

Make your space work.

HON®



2021 List Pricer

WORKSPACES

Desks | Workstations | Storage | Universal Screens

Supersedes HON List Pricer

Dated January 2020

LIST PRICER

Effective Date: January 2021

- All illustrations and specifications in this publication are based on the latest product information available at the time of print. For the most recent version, please go to <https://www.hon.com/pricer>.
- Software support packages furnished to the customer, either by The HON Company or by another source, which support the sale of HON products are superseded by printed price lists.
- All dimensions shown in this publication are nominal.
- Pricing is subject to change without notice.
- All orders are subject to prices in effect at the time of order.
- Ordering information appears at the beginning of a section complete with examples on how to specify. These specifying information pages are referenced at the bottom center of product pages.
- HON Full Lifetime Warranty applies unless otherwise noted.
- HON nationwide customer service:
Phone: (800) 833-3964

HON LIST PRICER

Table of Contents

INTRODUCTION

Table of Contents.....	1-4
Additions.....	5-6
Discontinuations.....	7
HON Full Lifetime Warranty Information.....	8
HON Limited 5-Year Warranty Information.....	9
Ordering Information.....	10
Integrated Design Solutions.....	11
Tailored Solutions Ordering Information.....	12
Customer's Own Material Ordering Information.....	13-14
Partnership Textile Information.....	15
Paint Program.....	16
Environmental Statement.....	17
Important Information.....	18
Legend.....	19
Fabric Patterns & Codes.....	20
Lead Times.....	21
Fabric Patterns & Codes.....	22-24
Panel Fabric Patterns & Codes.....	25-26

DESKS

Features Offered on HON Laminate Caseloads.....	27
Concinnity™	28
Concinnity™ Ordering Information	29
Concinnity™ Ordering Specification/Model Logic	30-31
Concinnity™ Laminate Design/Materials Information	32-33
Concinnity™ Laminate Ordering/Specification Information	34-35
Concinnity™ Cord Management.....	36-37
Concinnity™ Typicals.....	38-42
Concinnity™ Desks.....	43-45
Concinnity™ Peninsulas.....	46-47
Concinnity™ Corner Unit.....	48
Concinnity™ Credenzas.....	49
Concinnity™ Low Credenzas.....	50
Concinnity™ Returns.....	51
Concinnity™ Bridges.....	52
Concinnity™ Stack-on Storage Applications	53-54
Concinnity™ Stack-on Storage.....	55-59
Concinnity™ Wall Mount Storage Applications	60-61
Concinnity™ Wall Mount Storage.....	62-65
Concinnity™ Bookcase Hutches.....	66-67
Concinnity™ Reception Stations.....	68-70
Concinnity™ Mobile Pedestals.....	71
Concinnity™ Lateral Files.....	72
Concinnity™ Storage Cabinets.....	73-74
Concinnity™ Wardrobes.....	75
Concinnity™ Storage Towers.....	76
Concinnity™ Bookcases.....	77
Concinnity™ Components	78-79
Concinnity™ Components — Worksurfaces.....	80-83
Concinnity™ Components — Supports.....	84
Concinnity™ Components.....	85
Concinnity™ Components — Modesty/Back Panels.....	86-88
Concinnity™ Modesty/Back Panels.....	89
Concinnity™ Components — Supports.....	90

Concinnity™ Kneespace Clearance End Panels.....	91
Concinnity™ Components — Supports.....	92-96
Concinnity™ Height Adjustable Bases.....	97
Concinnity™ Components — Privacy Screens.....	98
Concinnity™ Privacy Screens.....	99
Concinnity™ Components — Supports.....	100-103
Concinnity™ Components — Pedestal Tops.....	104
Concinnity™ Components — Pedestal Back Panels.....	105
Concinnity™ Accessories.....	106-107
Concinnity™ Accessories — Cable Management & Electrical.....	108-109
Concinnity™ Accessories — Paper Organizers.....	110
Concinnity™ Paper Organizer Compatibility.....	111
Concinnity™ Accessories — Lock Kits.....	112
Concinnity™ Accessories — Task Lights.....	113
Concinnity™ Accessories.....	114-116
Coze™	117
Coze™ Table Desks.....	118-119
Mod	120
Mod Ordering Information	121
Mod Laminate Grain Direction	122
Mod Typicals.....	123-125
Mod Bundles Typicals.....	126-129
Mod Laminate Modular Components.....	130-131
Mod Laminate Modular Storage Components.....	132-134
Mod Laminate and Metal Desk Modular Components.....	135
Mod Laminate Modular Storage Components.....	136
Mod Conference Table Modular Components.....	137
Mod Reception Modular Components.....	138
Valido®	139
Valido® Ordering Information	140
Valido® Typicals.....	141-143
Valido® Laminate Modular Desks.....	144
Valido® Modular Credenzas.....	145
Valido® Modular Returns.....	146
Valido® Laminate Modular Components.....	147-148
Valido® Laminate Wood Desks — Full Pedestals.....	149-150
Valido® Laminate Wood Desks — 3/4 Pedestals.....	151-152
Valido® Shared Components & Accessories.....	153-169
Valido® Accessories.....	170-171
Voi®	172
Voi® Ordering Information	173
Voi® Laminate Typicals.....	174-180
Voi® Bundles Typicals.....	181-183
Voi® Specifying/Design Guide	184-188
Voi® Laminate Worksurfaces — Rectangle.....	189-191
Voi® Worksurface Supports.....	192-194
Voi® Standing-Height Worksurface Supports.....	195
Voi® Standing-Height Laminate Support.....	196
Voi® — Coordinate™ Sit-to-Stand Worksurfaces.....	197
Voi® Height Adjustable Bases.....	198
Voi® Laminate Support/Support Pedestals.....	199
Voi® Laminate Support/Support Storage.....	200
Voi® Modesty Panels.....	201-202
Voi® Privacy Screens.....	203-205

Voi® Laminate Overhead Storage.....	206
Voi® Laminate Overhead and Stack-on Storage.....	207
Voi® Laminate Shared Overhead Storage Components.....	208
Voi® Overhead Storage Supports/Accessories.....	209
Voi® Laminate Stack-on Storage — Built-up.....	210
Voi® Laminate Low Credenzas.....	211-212
Voi® Laminate Low Footed Credenzas.....	213-214
Voi® Laminate Credenzas.....	215
Voi® Laminate Mobile Storage.....	216
Voi® Laminate Storage.....	217
Voi® Laminate Storage Cubes.....	218
Voi® Laminate Storage Cube Bundles.....	219
Voi® Laminate Storage Towers.....	220-222
Voi® Laminate Storage.....	223
Voi® Laminate Bookcases.....	224
Voi® Accessories.....	225-231
Voi® Softwire Electrical Components.....	232
Voi® Electrical Components.....	233-234
10500 Series™	235
10500 Series™ Ordering Information	236-237
10500 Series™ Typicals.....	238-240
10500 Series™ Bundles Typicals.....	241-243
10500 Series™ Laminate Modular Components.....	244-248
10500 Series™ Worksurfaces.....	249
10500 Series™ Worksurface Supports.....	250-254
10500 Series™ Components — Supports.....	255
10500 Series™ Height Adjustable Bases.....	256
10500 Series™ Shared Components.....	257-258
10500 Series™ Laminate Modular Components.....	259-261
10500 Series™ Laminate Wood Desks — Full Pedestals.....	262-265
10500 Series™ Laminate Wood Desks — 3/4 Pedestals.....	266-267
10500 Series™ Shared Components & Accessories.....	268-278
10500 Series™ Storage.....	279
10500 Series™ Shared Components & Accessories.....	280-290
10500 Series™ Laminate Occasional Tables.....	291
10500 Series™ Shared Components & Accessories.....	292-295
10500 Series™ Accessories.....	296-297
10700 Series™	298
10700 Series™ Ordering Information	299
10700 Series™ Typicals.....	300-302
10700 Series™ Bundles Typicals.....	303-305
10700 Series™ Laminate Modular Components.....	306-311
10700 Series™ Laminate Wood Desks — Full Pedestals.....	312-313
10700 Series™ Laminate Wood Desks — 3/4 Pedestals.....	314-315
10700 Series™ Shared Components and Accessories.....	316-328
10700 Series™ Accessories.....	329-330

For information regarding HON registered and unregistered trademarks, please go to hon.com/protected-marks. Haworth®, Herman Miller®, Knoll®, and Steelcase® are registered trademarks of their respective owners and use of the marks do not imply affiliation or endorsement of The HON Company or its products.

LIST PRICER

Effective Date: January 2021

- All illustrations and specifications in this publication are based on the latest product information available at the time of print. For the most recent version, please go to <https://www.hon.com/pricer>.
- Software support packages furnished to the customer, either by The HON Company or by another source, which support the sale of HON products are superseded by printed price lists.
- All dimensions shown in this publication are nominal.
- Pricing is subject to change without notice.

- All orders are subject to prices in effect at the time of order.
- Ordering information appears at the beginning of a section complete with examples on how to specify. These specifying information pages are referenced at the bottom center of product pages.
- HON Full Lifetime Warranty applies unless otherwise noted.
- HON nationwide customer service:
Phone: (800) 833-3964

HON LIST PRICER

Table of Contents

94000 Series™331	Abound® Clear Glass Tiles.....432	Empower® Legs for 120° Applications.....500
94000 Series™ Typical.....332-333	Abound® Frosted Glass Tiles.....433	Empower® Support Beams.....501
94000 Series™ Laminate Wood Desks.....334-339	Abound® Frameless Glass.....434	Empower® Wire Troughs.....502
94000 Series™ Accessories.....340-342	Abound® Pass-thru Tiles.....435	Empower® Return Components.....503
Mentor®343	Abound® Slotted Tool Tiles.....436	Empower® Systems Worksurfaces.....504
Mentor® Ordering Information344	Systems Paper Management Support Bar.....436	Systems Worksurfaces — 120 Degree Corner.....505
Mentor® Steel Desks.....345-346	Systems Paper Management Accessories.....437	Empower® Height Adjustable Bases.....506
Mentor® Accessories.....347-349	Abound® Markerboard Tiles.....438	Empower® Systems Worksurfaces.....507
Metro Classic351	Abound® Painted Metal Tiles.....439	Empower® Side Screens.....508
Metro Classic Ordering Information352	Abound® Custom Material Bracket Kit.....440	Empower® Center Screens Fabric.....509
Metro Classic Steel Desks.....353-354	Abound® Gallery Panels — Wing.....441-442	Empower® Center Screens Frosted Glass.....510
Metro Classic Accessories.....355-357	Abound® Gallery Panels — Wing w/Glass.....443-444	Empower® Modesty Panels/End of Run Screens.....511
34000 Series359	Abound® Gallery Glass.....445	Empower® Typical.....512
34000 Series Ordering Information360	Abound® Gallery Connector Kits.....446	Empower® Height Adjustable Typical.....513
34000 Series Steel Desks.....361	Abound® Gallery Panel Tackboards.....447	Empower® Electrical Specifying Information514-517
34000 Series Accessories.....362-364	Abound® Gallery-to-Gallery Connections.....448-451	Empower® Electrical and Data.....518-519
38000 Series™366	Abound® Height Adjustable Tie-In Brackets.....452	Empower® Electrical Accessories.....520
38000 Series™ Ordering Information367	Accelerate®454	Empower® — Voi® Laminate Low Credenzas.....521-522
38000 Series™ Typical.....368	Accelerate® Ordering Information455	Empower® — Voi® Laminate Mobile Storage.....523
38000 Series™ Typical — Modular.....369	Accelerate® Fabric Patterns & Codes456-457	Empower® — Voi® Laminate Storage Towers.....524-525
38000 Series™ Bundles Typical.....370-371	Accelerate® Typical.....458-459	Empower® — Contain® Metal Credenzas.....526
38000 Series™ Steel Desks — 3/4 Pedestals.....372	Accelerate® Panels Overview.....460-461	Empower® — Contain® Footed Metal Credenzas.....527
38000 Series™ Modular Desks.....373	Accelerate® Working with Panels.....462	Empower® — Contain® Metal Credenzas
38000 Series™ Shared Components and	Accelerate® Connector Overview.....463	with Laminate Fronts.....528
Accessories.....374	Accelerate® Tackable Raceway Panels.....464	Empower® — Contain® Footed Metal Credenzas
38000 Series™ Accessories.....375-377	Accelerate® Top-Tier Glass Panels.....465	with Laminate Fronts.....529
38000 Series™ Steel Stack-on Units.....378-380	Accelerate® Panel Door.....466	Empower® — Contain® Metal Credenzas
	Accelerate® Top Caps.....467	Accessories.....530
	Accelerate® Stacking Panels.....468-469	Empower® — Contain® Metal Personal Towers.....531
	Accelerate® Frameless Glass.....470	Empower® — Contain® Metal Side Access Towers.....532
	Accelerate® Strengthened Connection Posts.....471	Empower® — Contain® Metal Personal Towers
	Accelerate® Strengthened Connections —	with Laminate Fronts.....533
	Connector Straps.....472	Empower® — Contain® Metal Side Access Towers
	Accelerate® Variable Height Finished End	with Laminate Fronts.....534
	and Wall Starter Kits.....473	Empower® — Contain® Footed Metal Personal
	Accelerate® Bracket Kits and Stability Feet.....474	Towers.....535
	Empower®475	Empower® — Contain® Footed Metal Side Access
	Empower® Fabric Screens — All Panel	Towers.....536
	Models476-477	Empower® — Contain® Footed Metal Personal
	Empower® Finish Options478	Towers with Laminate Fronts.....537
	Empower® Step-by-Step Guide479	Empower® — Contain® Footed Metal Side Access
	Empower® 72"W Typical with 24"D	Towers with Laminate Fronts.....538
	Worksurfaces.....480-482	Empower® — Contain® Metal Pedestals.....539
	Empower® 60"W Typical with 24"D	Empower® — Contain® Footed Metal Pedestals.....540
	Worksurfaces.....483-484	Empower® — Contain® Metal Pedestals
	Empower® 72"W Typical with 30"D	with Laminate Fronts.....541
	Worksurfaces.....485-486	Empower® — Contain® Footed Metal Pedestals
	Empower® 60"W Typical with 30"D	with Laminate Fronts.....542
	Worksurfaces.....487-488	Empower® — Flagship® Mobile Pedestals.....543
	Empower® 120" Workstation Typical.....489-490	Empower® Workplace Tools.....544
	Empower® 72"W Height Adjustable Typical	Empower® Accessories.....545
	with 24"D Worksurfaces.....491-492	Systems Shared Components547
	Empower® 60"W Height Adjustable Typical	Systems Overhead and Shelves Specifying548-549
	with 24"D Worksurfaces.....493-494	Systems Overhead and Shelves.....550
	Empower® 72"W Height Adjustable Typical	Systems ETA Overheads and Shelves.....551
	with 30"D Worksurfaces.....495-496	Systems Overhead Storage.....552
	Empower® 60"W Height Adjustable Typical	Systems Laminate Front Overhead Storage.....553
	with 30"D Worksurfaces.....497-498	Voi® Overhead Storage.....554-555
	Empower® Legs for Linear Applications.....499	Voi® Overhead and Stack-on Storage.....556

For information regarding HON registered and unregistered trademarks, please go to [hon.com/protected-marks](https://www.hon.com/protected-marks). Haworth®, Herman Miller®, Knoll®, and Steelcase® are registered trademarks of their respective owners and use of the marks do not imply affiliation or endorsement of The HON Company or its products.

LIST PRICER

Effective Date: January 2021

- All illustrations and specifications in this publication are based on the latest product information available at the time of print. For the most recent version, please go to <https://www.hon.com/pricer>.
- Software support packages furnished to the customer, either by The HON Company or by another source, which support the sale of HON products are superseded by printed price lists.
- All dimensions shown in this publication are nominal.
- Pricing is subject to change without notice.
- All orders are subject to prices in effect at the time of order.
- Ordering information appears at the beginning of a section complete with examples on how to specify. These specifying information pages are referenced at the bottom center of product pages.
- HON Full Lifetime Warranty applies unless otherwise noted.
- HON nationwide customer service:
Phone: (800) 833-3964

HON LIST PRICER

Table of Contents

Voi® Shared Overhead Storage Components.....	557	Brigade® 600 Series Lateral Files w/Drawers.....	635	Fuse™.....	689
Systems Overhead and Shelves.....	558	Brigade® Metal Dividers.....	636	Fuse™ Ordering Information	690
Systems Accessories.....	559-560	Brigade® Steel Bookcases.....	637	Fuse™ Pedestals.....	691
Abound® Electrical and Data.....	561-565	Brigade® Storage Cabinets.....	638	Fuse™ Digital Lock Specifications.....	692
Systems Electrical and Data.....	566	Contain™	639	Fuse™ Mobile Pedestals.....	693
Systems Electrical Specifying Information	567-569	Contain™ Ordering Information	640	Fuse™ Mobile Pedestals with eLock.....	694
Working with Cable Management.....	570	Contain™ Metal Storage	641	Fuse™ Freestanding Pedestals.....	695
Systems Electrical Components.....	571-576	Contain™ Metal Credenzas.....	642	Fuse™ Freestanding Pedestals with eLock.....	696
Systems Electrical and Data.....	577	Contain™ Footed Metal Credenzas.....	643	Fuse™ Pedestal Cushion.....	697
Systems Working with Worksurfaces		Contain™ Metal Credenzas with Laminate		Fuse™ Undermount Storage.....	698
and Supports.....	578-580	Fronts.....	644	Fuse™ Workplace Tools.....	699
Systems Worksurfaces — Primary.....	581-582	Contain™ Footed Metal Credenzas with		Storage Islands	700
Systems Worksurfaces — Wedge.....	583	Laminate Fronts.....	645	Storage Islands Ordering Information	701
Systems Worksurfaces — Corner.....	584-585	Contain™ Personal Files.....	646	Storage Islands Specifying Guide.....	702-703
Systems Worksurfaces — 120 Degree Corner.....	586	Contain™ Lateral Files.....	647	Storage Islands Planning Typical.....	704-705
Systems Worksurfaces — Corner Cove.....	587-588	Contain™ Lateral File Accessories.....	648	Storage Islands Specifying Guide.....	706
Systems Worksurfaces — Jetty / Peninsula.....	589	Contain™ Metal Credenzas Accessories.....	649-650	Storage Islands Top Only Applications.....	707
Systems Worksurfaces — Half-Round /		Contain™ Towers.....	651	Storage Islands Tops for Use with 2 End Panels.....	708
Quarter Round / 60° Wedge.....	590	Contain™ Lockers & Wardrobes.....	652	Storage Islands Tops for Use with 2 End Panels	
Systems Countertops — Straight and Corner.....	591-592	Contain™ Digital Lock Specifications.....	653	and Back/Septum.....	709
Systems Shelves — Corner Shelves.....	593	Contain™ Metal Personal Towers.....	654	Storage Islands Tops for Use with 1 End Panel	
Coordinate™ Height Adjustable Bases —		Contain™ Metal Side Access Towers.....	655	and Septum.....	710
Two-Leg.....	594	Contain™ Metal Personal Towers with		Storage Islands Islands Septum/Back and End	
Coordinate™ Height Adjustable Bases —		Laminate Fronts.....	656	Panels.....	711
Three-Leg.....	595	Contain™ Metal Side Access Towers with		Storage Islands Peninsula Supports.....	712
Coordinate™ Height Adjustable Bases —		Laminate Fronts.....	657	400 Series	713
Simple Specification.....	596	Contain™ Footed Metal Personal Towers.....	658	400 Series Lateral Files	714
Coordinate™ Screens.....	597	Contain™ Footed Metal Side Access Towers.....	659	Vertical Files	715
Coordinate™ Accessories.....	598	Contain™ Footed Metal Personal Towers with		Vertical Files Ordering Information	716
Coordinate™ Worksurfaces.....	599-602	Laminate Fronts.....	660	210 Series Vertical Files — 28½”D.....	717
Coordinate™ Shared Components.....	603	Contain™ Footed Metal Side Access Towers with		310 Series Vertical Files — 26½”D.....	718
Systems Worksurface Supports.....	604-606	Laminate Fronts.....	661	510 Series Vertical Files — 25”D.....	719
Worksurface Brackets.....	607	Contain™ 18”W Slim Metal Personal Towers.....	662-663	Lateral File Accessories.....	720
Systems Worksurface Supports.....	608	Contain™ 18”W Slim Personal Towers with		Vertical File Accessories.....	721
Standing-Height Worksurface Supports.....	609	Laminate Fronts.....	664-665	Mobile Pedestals.....	722
Systems Standard Height Support Pedestals.....	610	Contain™ Wardrobes.....	666-667	Pedestal Accessories.....	723-724
Voi® Laminate Support Pedestals.....	611	Contain™ Metal Lockers.....	668	Laminate Bookcases	725
Voi® Laminate Support Storage.....	612	Contain™ Metal Lockers with Laminate Fronts.....	669	Bookcases Ordering Information	726
Systems Accessories — Paper Management /		Contain™ Metal Lockers with eLock.....	670	10500 Series™ Laminate Bookcases.....	727
Markerboards.....	613	Contain™ Metal Lockers with Laminate Fronts		1870 Series Laminate Bookcases.....	728
Systems Accessories — Task Lights.....	614	and eLock.....	671	Universal Screens	729
Systems Accessories — Electrical.....	615	Contain™ eLock Accessories.....	672	Acoustic Solutions	730
Systems Accessories — Monitor Arms.....	616	Contain™ Metal Pedestals	672A	Acoustic Solutions Ordering Information	730-731
Systems Accessories.....	617-618	Contain™ Footed Metal Pedestals.....	673-674	Acoustic Solutions Wall.....	732
Versé®	619	Contain™ Metal Pedestals with Laminate Fronts.....	675	Acoustic Solutions Ceiling Tiles and Screens.....	733
Versé® Panel System.....	620-623	Contain™ Footed Metal Pedestals with		Acoustic Solutions Floor Screens.....	734-735
		Laminate Fronts.....	676-677	Desktop Screens Ordering Information	736
STORAGE		Flagship™	678	Desktop Screens.....	737-738
Overview of Personal Storage and Pedestals	624	Flagship™ Ordering Information	679	Universal Screens Ordering Information	739
HON Lateral Files at a glance.....	625	Flagship™ Hanging and Standard Height		Universal Screens Table Screens.....	740-741
HON Vertical Files at a glance.....	626	Pedestals.....	680	Universal Screens Plexi-Glass Screens.....	742
Storage and Files Ordering Information	627	Flagship™ Mobile Pedestals.....	681	Universal Screens Floor Screens.....	743
Brigade®	628	Flagship™ 18” Deep Lateral Files with Drawers.....	682	Universal Screens Panel Stackers.....	744
Brigade® Ordering Information	629	Flagship™ Lateral File with Storage.....	683		
Brigade® Standard Height Pedestals.....	630	Flagship™ Modular Storage.....	684		
Brigade® 800 Series Lateral Files w/ Drawers.....	631	Flagship™ Bookcases.....	685		
Brigade® 800 Series Lateral Files w/Storage.....	632	Flagship™ Storage Cabinets.....	686	ACCESSORIES	
Brigade® 700 Series Lateral Files w/Drawers.....	633	Flamesafe™ Ordering Information	687	Core Removable Lock Kits.....	746
Brigade® 700 Series Lateral Files w/Storage.....	634	FlameSafe™ Fire-Resistant Files.....	688	Touch-up Paint.....	747

For information regarding HON registered and unregistered trademarks, please go to [hon.com/protected-marks](https://www.hon.com/protected-marks). Haworth®, Herman Miller®, Knoll®, and Steelcase® are registered trademarks of their respective owners and use of the marks do not imply affiliation or endorsement of The HON Company or its products.

LIST PRICER

Effective Date: January 2021

- All illustrations and specifications in this publication are based on the latest product information available at the time of print. For the most recent version, please go to <https://www.hon.com/pricer>.
- Software support packages furnished to the customer, either by The HON Company or by another source, which support the sale of HON products are superseded by printed price lists.
- All dimensions shown in this publication are nominal.
- Pricing is subject to change without notice.
- All orders are subject to prices in effect at the time of order.
- Ordering information appears at the beginning of a section complete with examples on how to specify. These specifying information pages are referenced at the bottom center of product pages.
- HON Full Lifetime Warranty applies unless otherwise noted.
- HON nationwide customer service:
Phone: (800) 833-3964

HON LIST PRICER

Table of Contents

BUNDLES

Bundles	748
MOD Bundles Typicals	749-751
Voi® Bundles Typicals	752-754
10500 Series™ Bundles Typicals	755-757
10700 Series™ Bundles Typicals.....	758-760
38000 Series™ Bundles Typicals.....	761-762

INDEX

Cross Reference Index	763-779
Information on Ordering Parts.....	784

DISCONTINUATIONS

Desks Effective Date

Foundation™ March 31, 2021
 Models: HLM7242BF, HLM7236BF, HBL72BFMODG, HLM7242, HLM7236, HLM6630, HLM6030, HLM72PEN, HLM72CRD, HLM60CRD, HLM48RET, HLM42RET, HLM48BRG, HLM42CU, HLM72HUT, HLM60HUT, HBL72HDG, HLMRECP, HLMRECPRET, HLMPPWC, HLMBBF, HLMFF, HLMBF, HLM65BC, HLMLATF, HLMC72R, HLMC48D, HLMW4824, HLMW6024, HLMW6624, HLMW7224, HLMW4830, HLMW6030, HLMW6630, HLMW7230

Manage® December 31, 2020
 Models: HMNG15PED, HMNG48WKS, HMNG60WKS, HMNG72WKS, HMNGDLEG

Storage Effective Date

Contain® April 6, 2020
 Models: HSTBX502424LBBFLA, HSTBX502424LBBFMA, HSTBX502424LBBFMN, HSTBX502424LBBFMR, HSTBX502424LFFLA, HSTBX502424LFFMA, HSTBX502424LFFMN, HSTBX502424LFFMR, HSTBX502424RBBFLA, HSTBX502424RBBFMA, HSTBX502424RBBFMN, HSTBX502424RBBFMR, HSTBX502424RFFLA, HSTBX502424RFFMA, HSTBX502424RFFMN, HSTBX502424RFFMR, HSTBX652424LBBFLA, HSTBX652424LBBFMA, HSTBX652424LBBFMN, HSTBX652424LBBFMR, HSTBX652424LFFLA, HSTBX652424LFFMA, HSTBX652424LFFMN, HSTBX652424LFFMR, HSTBX652424RBBFLA, HSTBX652424RBBFMA, HSTBX652424RBBFMN, HSTBX652424RBBFMR, HSTBX652424RFFLA, HSTBX652424RFFMA, HSTBX652424RFFMN, HSTBX652424RFFMR, HSTBX652424LBBFMA, HSTBX652424LBBFMN, HSTBX652424LBBFMR, HSTBX652424LFFMA, HSTBX652424LFFMN, HSTBX652424LFFMR, HSTBX652424RBBFMA, HSTBX652424RBBFMN, HSTBX652424RBBFMR, HSTBX652424RFFMA, HSTBX652424RFFMN, HSTBX652424RFFMR, HSTBX652424LBBFMA, HSTBX652424LBBFMN, HSTBX652424LBBFMR, HSTBX652424LFFMA, HSTBX652424LFFMN, HSTBX652424LFFMR, HSTBX652424RBBFMA, HSTBX652424RBBFMN, HSTBX652424RBBFMR, HSTBX652424RFFMA, HSTBX652424RFFMN, HSTBX652424RFFMR, HSTSF502424LBBFLA, HSTSF502424LBBFMA, HSTSF502424LBBFMN, HSTSF502424LBBFMR, HSTSF502424LFFLA, HSTSF502424LFFMA, HSTSF502424LFFMN, HSTSF502424LFFMR, HSTSF502424RBBFLA, HSTSF502424RBBFMA, HSTSF502424RBBFMN, HSTSF502424RBBFMR, HSTSF502424RFFLA, HSTSF502424RFFMA, HSTSF502424RFFMN, HSTSF502424RFFMR

Storage Effective Date

Contain® (continued) April 6, 2020
 Models: HSTSF652424RFFMA, HSTSF652424RFFMN, HSTSF652424RFFMR, HSTSSF502424LBBFLA, HSTSSF502424LBBFMA, HSTSSF502424LBBFMN, HSTSSF502424LBBFMR, HSTSSF502424LFFLA, HSTSSF502424LFFMA, HSTSSF502424LFFMN, HSTSSF502424LFFMR, HSTSSF502424RBBFLA, HSTSSF502424RBBFMA, HSTSSF502424RBBFMN, HSTSSF502424RBBFMR, HSTSSF502424RFFLA, HSTSSF502424RFFMA, HSTSSF502424RFFMN, HSTSSF502424RFFMR, HSTSSF652424LBBFLA, HSTSSF652424LBBFMA, HSTSSF652424LBBFMN, HSTSSF652424LBBFMR, HSTSSF652424LFFLA, HSTSSF652424LFFMA, HSTSSF652424LFFMN, HSTSSF652424LFFMR, HSTSSF652424RBBFLA, HSTSSF652424RBBFMA, HSTSSF652424RBBFMN, HSTSSF652424RBBFMR, HSTSSF652424RFFLA, HSTSSF652424RFFMA, HSTSSF652424RFFMN, HSTSSF652424RFFMR, HSFACB283018BBFLA, HSFACB283018BBFMA, HSFACB283018BBFMN, HSFACB283018BBFMR, HSFACB283018BFFLA, HSFACB283018BFFMA, HSFACB283018BFFMN, HSFACB283018BFFMR, HSFACB283018BFFLA, HSFACB283018BFFMA, HSFACB283018BFFMN, HSFACB283018BFFMR, HSLBF283018BFFLA, HSLBF283018BFFMA, HSLBF283018BFFMN, HSLBF283018BFFMR, HSLBF283018BFFLA, HSLBF283018BFFMA, HSLBF283018BFFMN, HSLBF283018BFFMR, HSCBX223018BFFLA, HSCBX223018BFFMA, HSCBX223018BFFMN, HSCBX223018BFFMR, HSCBX223618BFFLA, HSCBX223618BFFMA, HSCBX223618BFFMN, HSCBX223618BFFMR, HSCBX224818BFFLA, HSCBX224818BFFMA, HSCBX224818BFFMN, HSCBX224818BFFMR, HSCBX226018BFFLA, HSCBX226018BFFMA, HSCBX226018BFFMN, HSCBX226018BFFMR, HSCBX227218BFFLA, HSCBX227218BFFMA, HSCBX227218BFFMN, HSCBX227218BFFMR, HSCSF223018BFFLA, HSCSF223018BFFMA, HSCSF223018BFFMN, HSCSF223018BFFMR, HSCSF223618BFFLA, HSCSF223618BFFMA, HSCSF223618BFFMN, HSCSF223618BFFMR, HSCSF224818BFFLA, HSCSF224818BFFMA, HSCSF224818BFFMN, HSCSF224818BFFMR, HSCSF226018BFFLA, HSCSF226018BFFMA, HSCSF226018BFFMN, HSCSF226018BFFMR, HSCSF227218BFFLA, HSCSF227218BFFMA, HSCSF227218BFFMN, HSCSF227218BFFMR, HSCSF227218BFFLA, HSCSF227218BFFMA, HSCSF227218BFFMN, HSCSF227218BFFMR

HON FULL LIFETIME WARRANTY INFORMATION



FULL LIFETIME WARRANTY

YOUR HON FULL LIFETIME WARRANTY

Every time you purchase a HON product, you're making an investment in your future. We're proud to play a part in that future, and you can trust us to do our best for as long as you need us.

The HON Full Lifetime Warranty is our assurance to you that the HON desks, workstations, seating, tables, or storage you purchase will be free from defective material or workmanship for the life of the product.

In the unlikely event that any HON product or component covered by the HON Full Lifetime Warranty should fail under normal workplace use as a result of defective material or workmanship, HON shall repair or replace with comparable product (at HON's discretion), free of charge.

WHAT'S COVERED BY THE HON FULL LIFETIME WARRANTY?

Your HON Full Lifetime Warranty applies to product manufactured after January 1, 2011. All HON product lines, materials, and components are covered by the HON Full Lifetime Warranty except for the items described below.

The specific product lines, materials, and components listed below are covered under HON's Full 12-Year, Full 10-Year, and Full 5-Year Warranties (from date of purchase).

HON'S FULL 12-YEAR WARRANTY

- Electrical components (LED task lights, lamps and ballasts are not covered)
- 4-Way Stretch Mesh
- Seating controls
- Pneumatic Cylinders
- Wood Seating
- Accessories
- Laminate Surfaces
- Veneer Surfaces

HON'S FULL 10-YEAR WARRANTY

- Soothe® Patient Recliner Mechanism

HON'S FULL 7-YEAR WARRANTY

- Coordinate™ Height Adjustable Bases

HON'S FULL 5-YEAR WARRANTY

- All LED task lights
- Panel and seating textiles
- Electric Height Adjustable Bases (Including Memory Control)
- Coordinate™ Desktop Sit-to-Stand Risers
- Soothe® Patient Recliner Central Lock Mechanism
- Soothe® Patient Recliner Pivoting Arm
- Between™ Multi-Purpose Table
- Acoustic Solutions by Unika Vaev
- Mod

These warranties apply to HON products sold within the United States of America, U.S. Territories, and Canada, as well as U.S. Military and Federal Agency purchases (regardless of location).

IS ANYTHING NOT COVERED?

There are a few exclusions to the HON Full Lifetime Warranty and to the 12-, 10-, and 5-year warranties. These exclusions are:

- All HON products that are covered under a separate 5-year warranty.
- Color-fastness or matching of colors, woodgrains, or textures occurring in wood, leather, or other materials that naturally exhibit inherent color variations.
- Customer's own materials (COM) selected by and used at the request of the user.
- Modifications or attachments to the product that are not approved by The HON Company and product failures resulting from such modifications or attachments.
- Product normal wear and tear, which are to be expected over the course of ownership.
- Products that were not installed, used, or maintained in accordance with product instructions and warnings.
- Products used for rental purposes.
- Damage caused by cleaning chemicals.
- Dye transfer caused by external contaminants (including clothing and accessory dyes such as those used on denim jeans) may migrate to lighter colors. This phenomenon is increased by humidity and temperature and is irreversible.
- Fabric pattern match seat to back or chair to chair. If pattern match is needed, please submit a Tailored Solutions request or contact HON Customer Support/Tailored Solutions with questions.

WARRANTY REQUESTS OR QUESTIONS?

Your HON Dealer is our mutual partner in supporting your warranty requests. To obtain service under this warranty, please contact your HON dealer. If you are not sure who your dealer is, please call HON Customer Support at 800.833.3964.

THAT'S YOUR HON FULL LIFETIME WARRANTY AS AN OWNER OF HON PRODUCT, THE WARRANTY EXPLAINED HERE IS YOUR SOLE AND EXCLUSIVE REMEDY. THERE ARE SOME EXCEPTIONS IF YOU PURCHASED THE PRODUCT FOR HOME OR PERSONAL USE WHICH ARE EXPLAINED BELOW. TO THE EXTENT ALLOWED BY LAW, THE HON COMPANY MAKES NO OTHER WARRANTY, EITHER EXPRESS OR IMPLIED, INCLUDING ANY WARRANTY OF MERCHANTABILITY OR FITNESS FOR A PARTICULAR PURPOSE. THE HON COMPANY WILL NOT BE LIABLE FOR ANY CONSEQUENTIAL OR INCIDENTAL DAMAGES.

A WORD ABOUT PURCHASES FOR HOME OR PERSONAL USE

Please note, this section only applies if you purchased your HON product for your home or for your own personal or family use. HON's warranties give you specific legal rights and you may have other rights, which vary from state to state. As a consumer purchaser, the complete exclusion of implied warranties noted in the above paragraph does not apply to you, however, to the extent allowed by applicable state law, the implied warranties are limited to the applicable term of the warranty. Some states do not allow the exclusion or limitation of incidental or consequential damages, so the above exclusion or limitation may not apply to you.

HON LIMITED 5-YEAR WARRANTY INFORMATION



LIMITED 5-YEAR WARRANTY

The HON Company promises to repair or replace HON products or components covered under this warranty that are found to be defective in material or workmanship within five (5) years from the date of original purchase so long as you, the original purchaser, still owns it. This is your sole and exclusive remedy. This warranty is subject to the provisions below. It applies to the products listed here manufactured after January 1, 2018.

LIMITATIONS:

- Upholstery on chairs is warranted for two years from date of purchase.
- Damage caused by the carrier in-transit is handled under separate terms.

EXCLUSIONS:

This warranty does not apply and no other warranty applies to:

- Normal wear and tear, which are to be expected over the course of ownership.
- Modifications or attachments to the product that are not approved by The HON Company.
- Products that were not installed, used or maintained in accordance with product instructions and warnings.
- Products used for rental purposes.

SEATING USAGE

Normal commercial use for seating is identified as the equivalent of a single shift, forty-(40) hour workweek. To the extent that a seating product is used in a manner exceeding this, the applicable warranty period will be reduced in a pro-rata manner.

A WORD ABOUT COLOR VARIATIONS, FABRICS AND FINISHES:

The HON Company does not warrant the color-fastness or matching of colors, grains or textures of covering materials.

CUSTOMER'S OWN MATERIAL (COM)

Not available on HON products covered under the HON 5-year warranty.

TO THE EXTENT ALLOWED BY LAW, THE HON COMPANY MAKES NO OTHER WARRANTY, EITHER EXPRESS OR IMPLIED, INCLUDING ANY WARRANTY OF MERCHANTABILITY OR FITNESS FOR A PARTICULAR PURPOSE. THE HON COMPANY WILL NOT BE LIABLE FOR ANY CONSEQUENTIAL OR INCIDENTAL DAMAGES.

NOTICE TO PURCHASERS FOR HOME OR PERSONAL USE:

Federal law does not permit the exclusion of certain implied warranties for consumer products. Therefore, if you are purchasing this product for home or personal use, the exclusion of implied warranties noted in the above paragraph does not apply to you. Some states do not allow the exclusion or limitation of incidental or consequential damages, so the above limitation or exclusion may not apply to you. This warranty gives you specific legal rights, and you may also have other rights which vary from state to state.

This warranty applies only to products sold within the United States of America and the Commonwealth of Canada.

TO OBTAIN SERVICE UNDER THIS WARRANTY:

Your HON® Dealer is our mutual partner in supporting your warranty requests. By following the procedures outlined below, you can be assured of the best level of service. Please note: Consent of The HON Company must be obtained before any warranty work is performed. To obtain consent, please take the following steps:

1. Contact the Dealer from whom the product was purchased within 30 days of discovery of the defect. Be prepared to affirm that you are the original purchaser of the product and to provide the serial number(s) from the product in question.
2. Your Dealer will gather all pertinent information regarding the claim, inspect the product and contact a HON Company customer service representative. (Please allow a reasonable amount of time for inspection and review.)
3. If The HON Company affirms that the product in question is eligible under the conditions of the warranty as stated above, the customer service representative or another representative of the Company will determine whether to provide replacement parts, authorize repairs or replace the product.

ORDERING INFORMATION

ORDERING

Electronic ordering is the standard order process for HON. HON supports the following primary methods for the electronic transmission of orders and order related documents:

Electronic Ordering

Available in the HONReady portal at honready.hon.com. There are multiple options available for processing orders electronically.

Integration with the standard Office Furniture business systems or other pre-approved proprietary software packages.

SIF file upload using fully optioned SIF files into the electronic ordering applications.

Manual entry of line items into the electronic ordering application.

EDI-System to System Integration

With standard Office Product systems or other pre-approved proprietary software systems.

Training, technical set-up and support is available through our Dealer Operations Team at honready@honcompany.com.

ORDER REQUIREMENTS

- Customer must provide complete and correct information, including complete model number, finishes, colors, options, and quantity.
- If a bid quotation or other special pricing applies, such information must be clearly stated on the order with applicable bid number or contract number.
- Order Management contact name and phone number.
- Delivery Appointment contact name and phone number at the dealership or installation company. HON does not accept orders with end user appointment contacts.
- Dealer Sales Representative, primary or multiple DSRs.
- “Best Date Available” for the entire order is standard service for HON. If eligible, other Date Requests may be requested and must be submitted with the order. Other Date Requests are subject to review by HON prior to acceptance:
 - “Ship After” requests are eligible on all order sizes
 - “Deliver On” requests are eligible for full truckload orders
- Additional services outside of HON’s standard services may be available through HON’s ‘Enhanced Services’ for a corresponding fee. Requested services from ‘Enhanced Services’ must be provided at time of order placement.
- The Company reserves the right to require electronic orders or charge \$50 fee per Purchase Order (PO) for manual order processing.
- Failure to provide complete and accurate information results in delayed order entry and acknowledgment. Incomplete orders will not be produced and will be returned to Dealer for correction.

ACKNOWLEDGMENT SERVICE

- E-mailed acknowledgments are available by customer request.
- An acknowledgment will be emailed the morning of the next business day, unless order is placed on credit or other order hold.
- The order will not receive an acknowledged shipment date until all order holds are released.

ORDER CHANGES OR CANCELLATIONS

For Order Changes or Cancellations, please contact Customer Support at 800-833-3964.

TERMS AND CONDITIONS

See **HON NOW** on honready.hon.com for more information about HON NOW delivery, services and ordering information.

INTEGRATED DESIGN SOLUTIONS

HON INTEGRATED DESIGN SOLUTIONS

Need design assistance? We can help! Our expert design staff will create a professional design package that is sure to put you one step ahead of the competition. And the best part is – it's free!

AUDIT

We will check your drawing and parts list for accuracy. We verify quantity, specification accuracy, product compatibility and structural support.

PLAN & SPECIFY

We will provide a professional design package including a CAD furniture plan, 3-D line drawing and complete parts list based on the rough sketch and work order forms you supply.

VALUE ENGINEERING

We will optimize workstation layouts and propose potential cost saving measures to help your customer save money and make you more competitive and profitable.

RENDERING

We will create a photo realistic rendering of your furniture plan to help your customer visualize what their desired office space will look like.

*SPACE PLANNING (BILLABLE SERVICE)

Let our team do the creative work for you. Our low rates and expert staff will create a furniture layout and design that best suits your customer.

PLANNING TYPICALS

Quick planning ideas to share with your clients. Various settings showcasing desks, tables and workstations available in multiple formats. View them today under Design Resources on the HON Ready Portal.

CONTACT INTEGRATED DESIGN SOLUTIONS

Questions? Please reach out to your region's dedicated designer. Not sure how to reach your designer? Send us a note at the email below.

E-Mail: integrateddesign@honcompany.com



Solve® Chair shown with Coordinate™ Height Adjustable Table.

Project Space

A place for all HON Project Services

Project Space provides one platform to access the full portfolio of HON services including:

- Plan & Specify
- Audit
- Product Modification
- Special Laminates
- Value Engineering
- Rendering
- Customer's Own Material
- Dual Fabric Applications
- Space Planning
- Special Paints
- Project Bid Pricing

Submit your request on the Community powered by HNI, Projects.

Project Space Lead Time: 1-3 business days depending on complexity and size of your project.

TAILORED SOLUTIONS ORDERING INFORMATION

PRODUCT MODIFICATIONS

Modifications include structural and dimensional modifications to existing product and Dual Fabric Applications, when standard model is not available.

The HON Company, at its own discretion, may modify standard products to meet specific needs. Product specials can be requested on HON brand product only.

List prices contained in published list pricers are for standard catalog items only. Changes or alterations to catalog items other than those listed as catalog options are subject to additional charges. Pricing will only be furnished upon approval of the special request.

Requests to have the product produced in more than one fabric (e.g., fabric on the seat is different than the fabric on the back), are considered a Dual Fabric Applications request and follow the Product Modification request process within MyProjects.

SPECIAL LAMINATES

Special laminates include requests for laminates not available as part of The HON Company's standard offering. Requests for special laminates are subject to manufacturing approval and minimum order quantities. The HON Company approved special laminates will be subject to a designated upcharge per unit.

Requests for special laminates should be submitted through the MyProjects Application on the HON Ready portal. Pricing will only be furnished upon approval of the special request.

SPECIAL PAINTS

- The HON Company's paint matching equipment can match almost any color, excluding some metallic and whites.
- Special paint requests must be submitted on the HON Ready Portal MyProjects application.
- In order to request a paint sample, the customer must have a minimum order of 10 like product units. Any requests with less than that amount will not be processed.
 - For each new paint request, there will be a \$500 net charge. A sample of the exact color desired is required for matching and approval. The HON Company will match the color and provide a production sample for the customer to review and approve.

- Once the signed paint sample is received at The HON Company, the request will be approved.
- Each unique color or finish combination incurs a designated upcharge per color per order (all standard discounts/competitive project pricing applies).

Special note: Some special colors could fall outside of this program due to production costs or not meeting The HON Company's quality standards. The HON Company may apply additional charges to some colors which are costly to apply, and refuse some orders on colors that cannot meet The HON Company's high quality standards. The HON Company will notify the customer upon completion of The HON Company's evaluation if a change in price is required or rejection of the order.

DISCONTINUED PRODUCT

Requests for discontinued product require engineering evaluation, safety review, and testing to current standards prior to approval. Many discontinued products are not available for order. Requests for discontinued products should be submitted through the MyProjects Application on the HON Ready portal.

LEAD TIMES FOR SPECIALS PRODUCT

Lead times on orders containing specials are subject to production capacity and material availability. When possible, the customer should order special products separately to avoid extended lead times for standard products. Extended lead times will be noted on the specials request.

CHANGES TO SPECIALS PRODUCT

A special model will be provided for each approved special item to process orders. Once an order is placed, no changes or cancellations can be made to the order without approval from Tailored Solutions.

CONTACT TAILORED SOLUTIONS

Phone: 800.833.3964 and listen for Tailored Solutions offering on the menu.

Email: HONSpecials@honcompany.com

CUSTOMER'S OWN MATERIAL ORDERING INFORMATION

CUSTOMER'S OWN MATERIAL (COM) PROGRAM

Customer's Own Material (COM) is a request to use fabrics not available as part of HON's standard fabric offering. Manufacture to Supply (MTS) and Dealer to Supply (DTS) are the two ordering methods. The HON Company has partnered with fabric manufacturers to provide competitive pricing and selection through the MTS program. MTS will be the standard offering unless The HON Company is unable to procure the fabric. If there is a DTS request submitted, The HON Company will advise at the time of the request if DTS is available.

CUSTOMER WARRANTY EXCLUSION

The HON Company shall have no responsibility for the condition, quality, value, performance, physical properties, or any other aspects of the COM.

The HON Company shall have no liability for any damages, injuries, or losses to the customer or to any third party that shall be caused by any COM or product modification, and the customer shall hold The HON Company harmless for all liability.

The HON Company assumes no responsibility for the overall appearance, flammability, normal durability, colorfastness, or any other quality of the COM or product modification after its application on a HON product beyond normal quality standards. The HON Company reserves the right to reject a COM fabric if the quality of the COM is not satisfactory for the product. Should this occur, the customer will be notified with an explanation of the issue.

The HON Company is not responsible for fabric that has become obsolete at the COM supplier, that is of poor quality, or that is delivered late to The HON Company from the COM supplier. The HON Company is not responsible for excess yardage created by DTS orders and reserves the right to dispose of the excess fabric.

As a standard HON does not pattern match any standard, partnership or COM fabric, therefore pattern match is not applicable under warranty. If pattern match is needed please submit a Tailored Solutions request or contact HON Customer Support/Tailored Solutions once your COM has been approved.

COM TESTING

As a result of recent legal requirements, The HON Company will need to obtain specific information from the fabric supplier about treatments and chemicals used in the fabric. To the extent the supplier is unwilling or unable to provide the necessary information, which could extend the testing lead time of the request.

To check if a COM has been tested previously, utilize the COM Search Tool on the HON Ready Portal > Design Resources > Textiles & Finishes section using the following information:

- COM Supplier's Name
- Fabric Pattern Name
- Color Name
- If the COM fabric has been tested and previously approved, the COM will not need to be re-tested unless testing

standards have changed, fabric is to be used on a different series, or direction of the fabric has changed from what was previously approved. Please note that Panel product must be approved for each model and color.

- If the pattern has previously been tested and approved, but not in the specific requested color, the customer will need to request an order code for that color only. No further testing will be necessary since the pattern has already been approved.

If the fabric has not previously been tested, the customer must enter the COM request on the HON Ready Portal > Textiles & Finishes > COM Search Tool.

Complete the Supplier Name, Pattern, and Color drop-down fields. For quicker results in these fields, type the first letter of the (supplier, pattern, color) name and, when done, click Add and then Submit. (Multiple series can be added to the same request if they are the same supplier, pattern, and color.)

An email will be sent to the requestor stating the COM Request was successfully submitted. Up to four emails could be received: submitted, in testing, testing materials requested, and final approval/denial with price grade and fabric code. The testing process takes approximately 48 hours.

COM yardage in the pricer is shown as pattern cut only.

COM TESTING — CAL 133 TESTING INFORMATION

The customer is responsible for ensuring that the COM fabric is certified to meet all flame-retardant requirements. All COM seating fabric must, at minimum, meet CAL 117 requirements. If the customer requires the chair be tested to meet the fire safety standards of CAL 133, additional testing and information is required.

All CAL 133 requests must be submitted through the MyProjects application on the HON Ready Portal. Each request must be entered separately since each request will need to be tested individually.

Once the supplier provides the requirements to The HON Company, testing will begin. The customer will receive approval or denial information upon completion of testing.

If the test is approved, a specific model number including "FC" at the end will be provided with an appropriate price.

MTS COM

As previously mentioned, MTS is the primary COM method.

If the COM fabric has not been tested, a COM request must be submitted on the HON Ready Portal.

For MTS orders, The HON Company will procure fabric needed for production. Should The HON Company not be able to obtain fabric yardage, the customer will be contacted.

CUSTOMER'S OWN MATERIAL ORDERING INFORMATION

When testing has been completed, the customer will be notified by the COM team of the test results. If the COM is approved, The HON Company will provide a COM tracking order code for MTS. That tracking code is required on the order in place of the standard fabric code.

If approved, MTS product will be assigned an appropriate fabric grade for pricing. The pricing can be found on the HON Ready Portal > Design Resources > Textiles & Finishes. (All standard discounts/competitive project pricing applies).

Written COM price quotes are valid for 90 days after the issue date.

DTS COM

DTS COM is only available if the COM fabric cannot be procured by The HON Company. If the fabric can be procured by The HON Company, the customer will be contacted to switch to MTS or cancel the request.

If your fabric is not listed as approved, and it is not a Partnership fabric you may request a "Dealer to Supply" code. Select the "Request COM Test" link on the COM Search website. Complete the Supplier Name, Pattern, and Color drop-down fields. For quicker results in these fields, type the first letter of the (supplier, pattern, color) name and, when done, click Add and then Submit. (Multiple series can be added to the same request if they are the same supplier, pattern, and color.)

An email will be sent to the requestor stating the COM Request was successfully submitted. Up to four emails could be received: submitted, in testing, testing materials requested, and final approval/denial with price grade and fabric code. It's rare actual test yardage is required. Testing is mainly done by reviewing the attributes of the fabric. The testing process takes approximately 48 hours.

If the COM has not been tested, a COM request must be submitted on the HON Ready Portal > Design Resources > Textiles & Finishes.

When testing has been completed, the customer will be notified by the COM team of the test results. If the COM is approved, The HON Company will provide a COM tracking order code. That tracking code is required on the order in the place of the standard fabric code.

DTS product is priced at the following grades (all standard discounts/competitive project pricing applies):

- Chairs are a Grade 4
- Panel product is a Grade D

Written COM price quotes are valid for 90 days after the issue date.

COM LEAD TIME

Ship dates will be based on fabric receipt and The HON Company's standard lead time. All fabric must be properly tagged and shipped to the appropriate producing location (provided in the approval email).

- Specific to DTS orders, COM orders will not receive a ship (acknowledged) date until The HON Company has the fabric in its possession for production.
- Specific to DTS orders, the customer may send the required yardage for the order to the address listed on the approval email to arrive no sooner than 4 weeks in advance of the acknowledgment date.

HON will make every effort to locate mis-directed COM shipments on behalf of the customer. However, The HON Company will not be responsible for any COM received without a tracking number or incorrectly shipped by the fabric vendor to an incorrect producing facility.

COM ORDERING INFORMATION

The following information must appear on or accompany the product purchase order:

- Approval tracking number and the customer's purchase order number
- COM supplier, pattern, and color name/number

The packing list for the COM must include the following information when The HON Company receives the shipment for production:

- Dealer or Wholesaler Name
- Purchase order number submitted to The HON Company
- Fabric name
- Yardage shipped
- Approval ordering code

If The HON Company receives fabric with incorrect labeling that cannot be linked to an order, The HON Company will hold the fabric for up to 7 days while the COM team attempts to identify the order. After 7 days, The HON Company will return the fabric to the sender.

Specific to DTS orders; the customer should send only the amount needed for the order. Excess yardage will be disposed of at The HON Company's discretion.

CHANGES TO COM PRODUCT

Once a COM product is ordered, no changes or cancellations can be made to the COM product without approval from the HON COM team.

CONTACT COM TEAM

Phone: 800.833.3964 and listen for COM TEAM offering on the menu.

COM Email: HONCOMTeam@honcompany.com

PARTNERSHIP TEXTILE INFORMATION

Partnership Textiles is the result of The HON Company's partnership with textile industry leaders Camira, Maharam, Stinson, and Ultrafabrics, LLC. The extensive collection of design-driven textiles create a superior offering at a great value. Partnership Textiles significantly updates HON's offering, expanding it with fresh and exciting options.

- **Fabric Warranty:** Partnership Textiles are covered by HON's Full Lifetime Warranty.
- **Lead Times:** Orders specified with Partnership Textiles will be acknowledged based on the supplier's availability and delivery schedule.
- **Availability:** The HON Company will regularly introduce new Partnership Textiles and reserves the right to change the offering at any time.
- **Fabric Cards:** A curated set of Partnership Textiles are carded jointly by HON and the supplier.

Camira

- Blazer

HBF Textiles

- Everyday Textures

Maharam

- Apt
- Bluff
- Collection 1
- Lariat
- Meld
- 6M

Stinson

- Edge
- Flow
- Reliance IV
- Square One

Ultrafabrics, LLC

- Brisa
- Ultraleather Pro

Fabric Memo Samples: Please contact the supplier directly:

Camira: memos@camirafabrics.com

HBF Textiles: Phone: +1 (877) 494-5727, orders@hbftextiles.com

Maharam: (800) 645-3943

Stinson: (800) 841-6279

Ultrafabrics: (877) 309-6648

HON BRANDED, PARTNERSHIP AND COM PATTERN MATCH

- **Pattern matching** provides alignment of patterns or stripes across individual chair surfaces. Additional yardage may be required depending on pattern repeat. If Pattern Match is needed, please contact HON Customer Support/Tailored Solutions.
- **Chair to Chair Pattern Match** provides identical pattern alignment from unit to unit and is available with an upcharge. Chair to Chair Pattern Match is reviewed on a case by case basis as several factors are reviewed to determine additional yardage required, including repeat and pattern direction. If Chair to Chair Pattern Match is needed, please contact HON Customer Support/Tailored Solutions.



PAINT PROGRAM

The HON Company has established paint grades to allow customers flexibility and ease in doing business with HON. HON has three paint grades P1, P2, and P3.

P1 PAINT COLORS

HON has established P1 paints which are available on a majority of core products.

P2 PAINT COLORS

Please see individual pricer pages for eligible series and upcharges for P2 paints. P2 paints are listed in the pricer pages under the column P2. Upcharges vary by product (all standard discounts/competitive project pricing applies). No minimum quantity required.

P3 PAINT COLORS

Please see individual pricer pages for eligible series and upcharges for P3 paints. P3 paints are listed in the pricer pages under the column P3. Upcharges vary by product (all standard discounts/competitive project pricing applies). No minimum quantity required.

SPECIAL PAINT COLORS (P4-P6)

With The HON Company's state of the art color matching equipment just about any color can be matched, excluding some metallic and whites. A sample of the exact color desired is required for matching and approval.

- For each newly requested paint, a net fee of \$500 will be charged to cover costs associated with the matching process.
- For existing, previously matched paints, there is no matching fee, however there is a \$100 net fee for sample panels required for the approval process. Refer to MyProjects on the HON Portal for a list of approved special paints.

For all special paint requests, HON will send a production sample for the customer to review and approve. Once the signed paint sample is received at HON the order can be entered. Upcharges vary by product (all standard discounts/competitive project pricing applies). A quantity of 10 like-model minimum order is required for special paints. For complete program details, access Tailored Solutions on the HON Ready Portal at honready.hon.com.

Some special colors could fall outside of this program due to production costs or not meeting HON quality standards. The HON Company may apply additional charges to some colors which are costly to apply, and deny some orders on colors that cannot meet our high quality standards. We will notify the customer upon completion of our evaluation if a change in price is required or if the request is denied.

ENVIRONMENTAL STATEMENT

We continually reevaluate our purpose and processes, from fostering transparency and circularity in our supply chain to empowering our members to do and be better. We do it so the environments you create will be safer, more socially responsible, and more sustainable.

We've pursued product certifications to help communicate our commitment to developing sustainable products.

Clearing the air.

In 2006, The HON Company became one of the first office furniture manufacturer to have products certified under the Indoor Advantage™ program. Virtually all manufactured products emit chemical compounds into the air. Indoor Advantage™ certification helps assure customers that certified products will help improve the air quality within their offices and workspaces.

Developed by SCS Global Services, Indoor Advantage™ evaluates products against indoor air quality standards, like ANSI/BIFMA Furniture Emissions Standard, X7.1 and CDPH. The ANSI/BIFMA X7.1 standard allows manufacturers to test individual components, as well as complete products for emissions from volatile organic compounds (VOCs). This allows us to identify problematic materials and phase them out of our products.

Indoor Advantage™ certified products meet the LEED v4 credits for low-emitting materials.

Indoor Advantage™ offers two levels of certification, including Indoor Advantage™ and Indoor Advantage™ Gold.



On the LEVEL®.

LEVEL®, the certification program for the BIFMA e3 Sustainability Standard, was developed in response to increasing demand for proof that manufacturers were living up to their environmental claims. LEVEL® is a multi-attribute sustainability certification label for products that have met criteria in four categories of impact: Materials, Energy and Atmosphere, Human and Ecosystem Health, and Social Responsibility.

LEVEL® offers three levels of certification:



Evaluating Our Impacts.

HON has begun studying the impacts our products have on the environment through lifecycle assessments and creating Environmental Product Declarations (EPDs). EPDs provide an understandable report of how a product impacts natural resources, the environment, and the atmosphere throughout its lifecycle.

Products that meet these specifications are identified throughout this publication with the following icons:

Certified SCS Indoor Advantage™



LEVEL® certified to the BIFMA e3 Sustainability Standard



Environmental Product Declarations

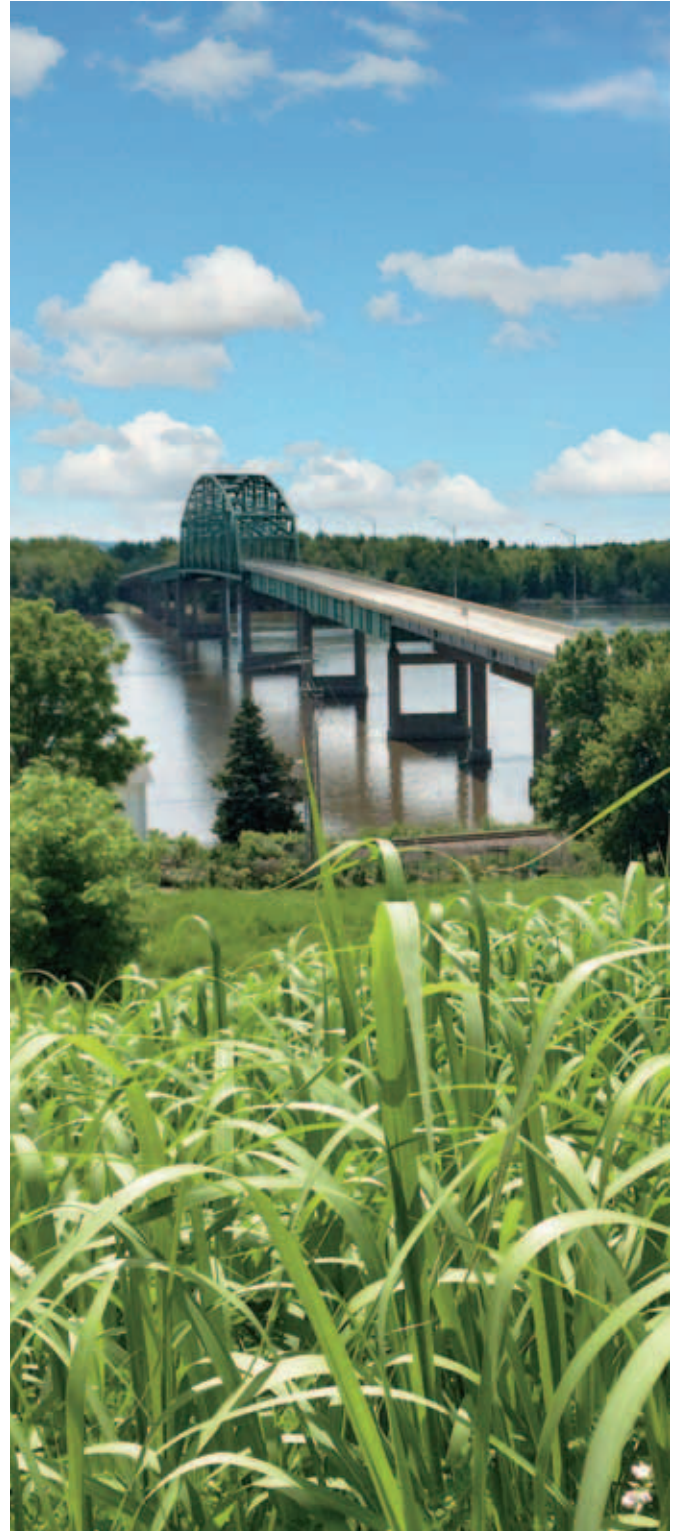

IMPORTANT INFORMATION

HON NOW™

We are inspired by the way you work. The chair you sit in. The space you choose to get it all done. We believe that well-designed office furniture should not only look good but be delivered quickly. Why wait for what you want and what you need right **NOW**?

HON NOW™ offers you a simple way to get the office solutions you need delivered with speed in mind. The office is changing and we are here to help you keep pace. No matter what space you are shopping for or product you need, HON NOW™ is made for the way you work.

GSA CONTRACT INFORMATION

Model numbers identified with the verbiage “**Open Market**” are not offered on HON’s GSA contract GS-27F-0015S. Model numbers identified with the following verbiage “Must be purchased with a configurable end product. If ordered separately, not on GSA contract” is to mean that these configurable components or options:

- Have no functionality or capability without being integrated into an end product, and
- Are not separately orderable; an eligible Schedule ordering activity may only purchase them with a configured system that is on contract.

HON CUSTOMER SUPPORT CONTACT INFORMATION

Nationwide CS Phone – (800) 833-3964

Nationwide CS Email – HONTeamBox@honcompany.com

Nationwide Order Entry – email: HONOE@honcompany.com

Government CS Phone – (800) 466-8694

GSA Team: HONGSATEAM@honcompany.com

GSA Order Entry: HONGSAOE@honcompany.com

Integrated Design Solutions – integrateddesign@honcompany.com

Online Order and Tool Support – HONReady@honcompany.com

DASH (transportation and delivery assistance) – (800) 334-8057

HON Literature Fulfillment Phone – (800) 466-4808



Nationwide CS Phone

800-833-3964

THE FOLLOWING ICONS MAY BE USED THROUGHOUT THIS PUBLICATION

-  Meets or exceeds ANSI/BIFMA and ISTA performance standards
-  Certified SCS Indoor Advantage™ See page 17 for more details.
-  Complies to the BIFMA e3 Sustainability Standard. See page 17 for more details.
-  Caution
-  Easy to assemble
-  Shippable by small-package carrier
-  Wheel-chair compatible
-  Soft-tread caster option available
-  HON “One Key” Interchangeable core removable locks (see page 746)
-  Omit core removable lock option available. Allows keyed alike workstations (see page 746).
-  Base models available on the HON NOW Quickship Program with select options and finishes. View the entire NOW collection at honready.hon.com.
-  Readily Available. For additional lead time information see page 21.
-  Available within a “standard” or “extended” lead time. For additional lead time information see page 21.
-  May have extended lead times. For additional lead time information see page 21.
-  Product shipped two to a carton
-  Product shipped four to a carton
-  Fire Code
-  Core Product Line
-  ColorCorrect® Eligible Product
-  Product scheduled for discontinuation
-  **DE-EMPHASIZED:** Product or fabric/surface material is de-emphasized, effective date as noted. Not carded. View online at honready.hon.com
-  Warranted for multiple shift use, 24 hours a day 7 days a week

FABRIC PATTERNS & CODES



FABRIC PATTERNS & CODES

- For additional HON to Supply COM fabric grade pricing, go to honready.hon.com and search on the HON to Supply COM link.
- All specifications in this publication are based on the latest product information available at the time of print.
- Certain dyes (including clothing and accessory dyes such as those used on denim jeans) may migrate to lighter colors. This phenomenon is increased by humidity and temperature and is irreversible. The HON Company LLC does not assume responsibility for dye transfer caused by external contaminants.
- COM Ordering Information and pricing on page 14.
- See page 15 for Partnership Textile program information.
- All standard fabrics are carded. Cards are available through HON Literature Fulfillment.
- Remember to add an FC to the base model number when fire code fabric is selected. New Models with FC Fire Code suffix meet CA Technical Bulletin 133. See pages 248-251 of the January 2021 Shared Spaces Pricer for available models/fabrics.
- Fabrics and foam meet requirements for CAL-TB 117-2013.
- Fire Code fabrics with FC foam meet requirements for CA Technical Bulletin 133.
- ❗ Different fabrics and finishes have different recommended cleaning and maintenance methods. For the correct product care for all finishes view the HON Product Care guide at hon.com/customer-support/product-care.

LEAD TIMES

THE FOLLOWING ICONS ARE USED TO DENOTE FABRIC OPTION LEAD TIMES

FABRIC/FINISH LEAD TIME INDICATOR



Fabric is readily available. Products using these fabrics will receive the best available product lead time and are a good option for standards programs as they will be in the HON portfolio for several years. Go to honready.hon.com and use **Compass** for product lead times by series.



Fabric is available within standard lead times. Products using these fabrics will receive a “standard” or “extended” lead time. The lead time will be determined by the combination of product and fabric. Go to honready.hon.com and use **Compass** for product lead times by series.



Fabric may have extended lead times. Products using these fabrics will typically have a 4+ week lead time. Go to honready.hon.com and use the **Compass** tool for product lead times by series.

HON EXPRESS QUICK SHIP PROGRAM

For the full list of products delivered in 5 business days or less, visit honready.hon.com.

PRODUCT LEAD TIMES

Standard lead times for products are between 2-4 weeks. For current exceptions to our standard lead time, go to honready.hon.com and use the **Compass** tool.

In order to establish accurate expectations for your project, please review this listing prior to submitting your purchase order.

Lead time calculation begins when order is free from any holds (i.e., bad lines, material, credit, etc.).

Please note, these production lead time estimates do NOT include delivery time. All published lead times are estimates, not guarantees of delivery.

For further information concerning lead times, please contact HON Customer Support via email HONTeamBox@honcompany or by phone at **800-833-3964**.

FABRIC PATTERNS & CODES

GRADE 1

APEX	APX
◆ Basalt	APX25
◆ Beet	APX12
◆ Blackberry	APX20
◆ Chive	APX05
◆ Iris	APX03
◆ Kiwi	APX06
◆ Lemonade	APX08
◆ Navy	APX13
◆ Papaya	APX09
◆ Pumice	APX23
◆ Rain	APX19
◆ Resort	APX15
◆ Royal	APX14
◆ Tiki	APX29
◆ Tomato	APX11

ATTIRE AI

◆ Blaze *	AI42
◆ Blue Lagoon *	AI90
◆ Crimson *	AI62
◆ Fatigue *	AI76
◆ Ivy *	AI82
◆ Lithium *	AI19
◆ Onyx *	AI10
◆ Sable *	AI49
◆ Taupe *	AI26
◆ Turquoise *	AI96

BLACK FABRIC ACCF

◆ Black	ACCF10
---------	--------

BLACK MESH ACCM

◆ Black	ACCM10
---------	--------

CENTURION CU

◆ Apricot	CU47
◆ Bark	CU25
◆ Black	CU10
◆ Espresso	CU49
◆ Fog	CU03
◆ Frost	CU22
◆ Goldenrod	CU27
◆ Indigo	CU06
◆ Iris	CU50
◆ Iron Ore	CU19
◆ Jade	CU83
◆ Marsala	CU63
◆ Morel	CU24
◆ Navy	CU98
◆ Peacock	CU97
◆ Pear	CU84
◆ Ruby	CU67
◆ Sapphire	CU09

GRADE 1 *continued*

COMPASS	COMP
◆ Beach	COMP16
◆ Bittersweet	COMP46
◆ Chocolate	COMP49
◆ Ink	COMP10
◆ Meadow	COMP82
◆ Midnight	COMP90
◆ Putty	COMP22
◆ Ruby	COMP62
◆ Sterling	COMP19
◆ Taupe	COMP26
◆ Tide	COMP96

COMPASS FOAM* COMF

◆ Bittersweet	COMF46
◆ Ink	COMF10
◆ Meadow	COMF82
◆ Midnight	COMF90
◆ Putty	COMF22
◆ Sterling	COMF19

**This fabric available for Solve* Upholstered Back models only.*

CONTOURETT UR

◆ Baltic	UR94
◆ Beach	UR23
◆ Black	UR10
◆ Bordeaux	UR63
◆ Buff	UR22
◆ Cloud	UR18
◆ Coffee Bean	UR49
◆ Crater	UR51
◆ Flame	UR62
◆ Graphite	UR19
◆ Iron	UR20
◆ Luggage	UR26
◆ Marine	UR92
◆ Navy	UR95
◆ Nimbus	UR93
◆ Ocean	UR96
◆ Pumpkin	UR42
◆ Quarry	UR24
◆ Red	UR64
◆ Safari	UR27
◆ Sage	UR82
◆ Steel	UR21
◆ Storm	UR17
◆ Taupe	UR28
◆ Trunk	UR50

GRADE 1 *continued*

DAPPER	DAPR
◆ Ash	DAPR20
◆ Azalea	DAPR95
◆ Breeze	DAPR06
◆ Canvas	DAPR25
◆ Charcoal	DAPR01
◆ Clover	DAPR22
◆ Currant	DAPR00
◆ Emerald	DAPR75
◆ Fawn	DAPR35
◆ Fern	DAPR85
◆ Gerbera	DAPR16
◆ Grape	DAPR33
◆ Jewel	DAPR08
◆ Marigold	DAPR65
◆ Onyx	DAPR10
◆ Orchid	DAPR90
◆ Parrot	DAPR59
◆ Peony	DAPR50
◆ Pool	DAPR05
◆ Poppy	DAPR19
◆ Rose	DAPR40
◆ Sapphire	DAPR07
◆ Scarlet	DAPR45
◆ Sepia	DAPR30
◆ Sky	DAPR44
◆ Slate	DAPR15
◆ Sorbet	DAPR55
◆ Spice	DAPR60
◆ Spring	DAPR80
◆ Terracotta	DAPR13
◆ Titanium	DAPR17
◆ Varsity	DAPR09
◆ Zest	DAPR70

ENSEMBLE ENSB

◆ Aquamarine	ENSB30
◆ Ash	ENSB39
◆ Greige	ENSB36
◆ Harbor	ENSB34
◆ Navy	ENSB35
◆ Oat	ENSB37
◆ Pear	ENSB33
◆ Sand	ENSB38
◆ Scarlet	ENSB32
◆ Slate	ENSB31
◆ Stone	ENSB40

GRADE 1 *continued*

HAMILTON	HAML
◆ Azure	HAML10
◆ Biscotti	HAML11
◆ Cabernet	HAML08
◆ Carolina	HAML21
◆ Charcoal	HAML17
◆ Chocolate	HAML13
◆ Cloud	HAML18
◆ Dane	HAML16
◆ Dusty Rose	HAML07
◆ Esmeralda	HAML06
◆ Fern	HAML04
◆ Fresh	HAML03
◆ Granola	HAML19
◆ Lilac	HAML14
◆ Lime	HAML05
◆ Lipstick	HAML09
◆ Oxford	HAML20
◆ Passion Fruit	HAML02
◆ Pepper	HAML15
◆ Powder	HAML12
◆ Sunrise	HAML01

INERTIA NR

◆ Amethyst	NR61
◆ Calypso	NR98
◆ Cherry	NR66
◆ Cobalt	NR91
◆ Coffee	NR49
◆ Fog	NR19
◆ Fuchsia	NR63
◆ Gecko	NR76
◆ Glow	NR27
◆ Leaf	NR75
◆ Lime	NR82
◆ Loft	NR22
◆ Mandarin	NR47
◆ Meteor	NR30
◆ Mustard	NR26
◆ Nickel	NR23
◆ Onyx	NR10
◆ Regatta	NR90
◆ Shadow	NR20
◆ Surf	NR96
◆ Tangelo	NR46

OPTIC OP

◆ Aurora	OP72
◆ Bark	OP24
◆ Canopy	OP84
◆ Char	OP49
◆ Ruby	OP42
◆ Sand	OP17
◆ Sky	OP83
◆ Slate	OP19
◆ Sprout	OP74
◆ Starry Night	OP11
◆ Storm	OP56
◆ Wildfire	OP66

* Fabric is de-emphasized.

FABRIC PATTERNS & CODES

GRADE 1 *continued*

PEBBLE	PBLE
◆ Amber	PBLE01
◆ Chalk	PBLE02
◆ Coal	PBLE03
◆ Gravel	PBLE04
◆ Magma	PBLE06
◆ Moss	PBLE05
◆ Sandstone	PBLE07
◆ Talc	PBLE08
◆ Topaz	PBLE09
◆ Zircon	PBLE10

GRADE 2

APPOINT SEATING	PNS
◆ Artichoke	PNS014
◆ Blackberry	PNS012
◆ Bronze	PNS002
◆ Carbon	PNS008
◆ Chai	PNS013
◆ Cherry	PNS010
◆ Dark Pewter	PNS017
◆ Dune	PNS015
◆ Espresso	PNS003
◆ Framboise	PNS011
◆ Frost	PNS034
◆ Jet	PNS007
◆ Lawn	PNS005
◆ Mandarin	PNS009
◆ Morel	PNS001
◆ Nimbus	PNS016
◆ Platinum	PNS004
◆ Turquoise	PNS006

BLUME	BLME
◆ Chalk	BLME03
◆ Char	BLME00
◆ Coin	BLME02
◆ Driftwood	BLME05
◆ Emerald City	BLME07
◆ Fir	BLME09
◆ Harvest	BLME04
◆ Haze	BLME08
◆ Hyacinth	BLME14
◆ Jasper	BLME13
◆ Merlot	BLME10
◆ Moonstone	BLME01
◆ Opal	BLME06
◆ Scarlet	BLME11
◆ Slate	BLME12

CLYDE	CLYD
◆ Antique	CLYD04
◆ Artifact	CLYD01
◆ Blacksmith	CLYD10
◆ Claret	CLYD13
◆ Craftsman	CLYD08
◆ Crate	CLYD12
◆ Fossil	CLYD02
◆ Heirloom	CLYD05
◆ Iron	CLYD11
◆ Linen	CLYD14
◆ Relic	CLYD06
◆ Seasoned	CLYD03
◆ Trestle	CLYD07
◆ Weathered	CLYD09

GRADE 2 *continued*

DOTTY	DOT
◆ Candy	DOT63
◆ Gelato	DOT34
◆ Indigo	DOT31
◆ Onyx	DOT35
◆ Park	DOT83
◆ Peat	DOT24
◆ Peony	DOT32
◆ Suit	DOT20
◆ Sunflower	DOT33
◆ Tailor	DOT21
◆ Tide	DOT90
◆ Velum	DOT29
◆ Violet	DOT30

RUSH	RUSH
◆ Anchor	RUSH07
◆ Basil	RUSH16
◆ Blueberry	RUSH10
◆ Flamingo	RUSH21
◆ Greenery	RUSH15
◆ Greyhound	RUSH06
◆ Marina	RUSH13
◆ Merlot	RUSH19
◆ Midnight	RUSH11
◆ Mint	RUSH09
◆ Mulberry	RUSH18
◆ Pumice	RUSH01
◆ Punch	RUSH20
◆ Sage	RUSH14
◆ Salsa	RUSH24
◆ Sand	RUSH05
◆ Seal	RUSH08
◆ Soot	RUSH02
◆ Stout	RUSH03
◆ Sunshine	RUSH23
◆ Tapestry	RUSH04
◆ Tiger	RUSH22
◆ Vintage	RUSH17
◆ Wave	RUSH12

SEED	SED
◆ Apple	SED11
◆ Ash	SED15
◆ Cardinal	SED09
◆ Cinder	SED17
◆ Cream	SED12
◆ Driftwood	SED13
◆ Harbor	SED10
◆ Onyx	SED18
◆ Smoke	SED16
◆ Truffle	SED14

GRADE 2 *continued*

SPIN SEATING	SPNN
◆ Alabaster	SPNN02
◆ Cavern	SPNN03
◆ Cobblestone	SPNN04
◆ Ember	SPNN06
◆ Flame	SPNN07
◆ Heron	SPNN13
◆ Oat	SPNN01
◆ Ocean	SPNN12
◆ Plum	SPNN15
◆ Pool	SPNN11
◆ Raven	SPNN10
◆ Rhubarb	SPNN14
◆ Tropic	SPNN08
◆ Willow	SPNN05

WHISPER VINYL	WP
◆ Antelope	WP20
◆ Black	WP40
◆ Bone	WP17
◆ Bordeaux	WP26
◆ Brick Red	WP99
◆ Camel	WP18
◆ Cappuccino	WP21
◆ Carotene	WP97
◆ Cashew	WP29
◆ Cerulean	WP36
◆ Charcoal	WP39
◆ Cinnamon	WP25
◆ Cognac	WP62
◆ Cucumber	WP88
◆ Elephant	WP38
◆ Espresso	WP49
◆ Fawn	WP91
◆ Fog	WP100
◆ Forest	WP82
◆ Gravel	WP19
◆ Indigo	WP86
◆ Luggage	WP23
◆ Mahogany	WP93
◆ Mallard	WP90
◆ Merlot	WP27
◆ Molten	WP98
◆ Navy	WP37
◆ Ochre	WP96
◆ Paradise	WP85
◆ Patina	WP34
◆ Pewter	WP83
◆ Putty	WP84
◆ Salsa	WP42
◆ Sangre	WP28
◆ Sassafras	WP89
◆ Storm	WP92
◆ Truffle	WP95
◆ Zest	WP87

FABRIC PATTERNS & CODES

GRADE 3

IN SEASON	ISN
◇ Black	ISN001
◇ Blue Jay	ISN007
◇ Fire	ISN004
◇ Jungle	ISN008
◇ Lake	ISN006
◇ Lead	ISN002
◇ Limestone	ISN041
◇ Ocean	ISN005
◇ Silver	ISN003
◇ Smoke	ISN020
◇ Tundra	ISN011

MOXIE

SX

◆ Barnwood	SX09
◆ Basalt	SX23
◆ Bayou	SX02
◆ Biscotti	SX08
◆ Blackberry	SX48
◆ Blarney	SX49
◆ Blueberry	SX05
◆ Bonsai	SX20
◆ Carob	SX24
◆ Chalk	SX50
◆ Chartreuse	SX34
◆ Cherry	SX38
◆ Cinnamon	SX13
◆ Cobalt	SX01
◆ Coconut	SX06
◆ Concrete	SX43
◆ Cumin	SX32
◆ Dragonfly	SX44
◆ Earl Grey	SX40
◆ Elysian	SX04
◆ Evergreen	SX21
◆ Fatigue	SX18
◆ Fawn	SX30
◆ Flint	SX39
◆ Hazel	SX31
◆ Hemp	SX45
◆ Hickory	SX25
◆ Holly	SX51
◆ Jam	SX16
◆ Kelly	SX33
◆ Lemongrass	SX19
◆ Lime	SX41
◆ Macintosh	SX12
◆ Mulberry	SX15
◆ Parchment	SX07
◆ Peacock	SX03
◆ Pineapple	SX42
◆ Plum	SX17
◆ Punch	SX46
◆ Riverstone	SX47
◆ Russet	SX14
◆ Smokestack	SX22
◆ Tangerine	SX37
◆ Terracotta	SX11
◆ Thicket	SX35
◆ Walnut	SX10

GRADE 3

continued

PARKER	PRKR
◇ Aloe	PRKR01
◆ Cumulus	PRKR05
◆ Cyan	PRKR06
◆ Domino	PRKR07
◆ Fossil	PRKR10
◆ Graphite	PRKR11
◇ Grass	PRKR12
◆ Grenadine	PRKR13
◆ Griffin	PRKR14
◆ Kiln	PRKR16
◆ Magnesium	PRKR18
◆ Magnet	PRKR19
◆ Mica	PRKR20
◆ Mink	PRKR21
◆ Nightfall	PRKR22
◆ Paprika	PRKR24
◆ Pine	PRKR25
◆ Rapids	PRKR28
◆ Rioja	PRKR30

PURL

PURL

◇ Alpaca	PURL08
◇ Braid	PURL10
◆ Deep	PURL12
◆ Graze	PURL05
◆ Loom	PURL06
◆ Needle	PURL07
◆ Pasture	PURL02
◆ Ranch	PURL04
◆ Shuttle	PURL09
◆ Skein	PURL01
◆ Thistle	PURL11
◆ Yearling	PURL03

QUILL

QUL

◇ Aviary	QUL03
◆ Feather	QUL02
◆ Fountain	QUL06
◆ Ink	QUL05
◆ Metal	QUL04
◆ Reed	QUL08
◆ Scroll	QUL01
◆ Well	QUL07

GRADE L1

DENVER LEATHER	SS
◆ Black	SS11

For a complete list of fabrics, including partnership fabrics, go to hon.com/fabricsandfinishes.

PANEL FABRIC PATTERNS & CODES

PRICE CODE AA		PRICE CODE A		PRICE CODE A <i>continued</i>		PRICE CODE A <i>continued</i>	
FACTOR	FACT	APPOINT	APN	ETCH*	ECH	REFLECTIONS*	REF
◆ Bark	FACT20	◆ Artichoke	APN11	◆ Axis	ECH13	◆ Galvanized	REF29
◆ Barley	FACT15	◆ Blackberry	APN32	◆ Blend	ECH14	◆ Ice	REF20
◆ Cascade	FACT25	◆ Bronze	APN22	◆ Cast	ECH12	◆ Loggia	REF21
◆ Feather	FACT30	◆ Carbon	APN28	◆ Highlight	ECH10	◆ Mistral	REF28
		◆ Chai	APN12	◆ Midtone	ECH11	◆ Moonstone	REF23
		◆ Cherry	APN30	◆ Outline	ECH08	◆ Pewter	REF22
		◆ Dark Pewter	APN17	◆ Shade	ECH09	◆ Stainless	REF24
		◆ Dune	APN15	◆ Tonal	ECH16	◆ Vanilla	REF25
		◆ Espresso	APN23	◆ Vanish	ECH15	◆ Winter	REF27
		◆ Framboise	APN31				
		◆ Frost	APN34	EXCHANGE*		REFUGE*	
		◆ Jet	APN27	EXG		RFG	
		◆ Lawn	APN25	◆ Iron	EXG916	◆ Artesian	RFG96
		◆ Mandarin	APN29	◆ Nickel	EXG914	◆ Dune	RFG92
		◆ Morel	APN09	◆ Pistachio	EXG910	◆ Eclipse	RFG90
		◆ Nimbus	APN16	◆ Root	EXG913	◆ Frost	RFG93
		◆ Platinum	APN24	◆ Rupee	EXG903	◆ Glacier	RFG91
		◆ Turquoise	APN26	◆ Shadow	EXG911	◆ Mineral	RFG98
				◆ Silver	EXG915	◆ Tidal	RFG94
				◆ Sisal	EXG917		
				◆ Stone	EXG912		
		CENTURION		LANDSCAPE*		SARTO*	
		CU		LN		SRT	
		◆ Apricot	CU47	◆ Azure	LN55	◆ Ash	SRT88
		◆ Bark	CU25	◆ Cornsilk	LN15	◆ Fog	SRT14
		◆ Black	CU10	◆ Drift	LN05	◆ Lemongrass	SRT49
		◆ Espresso	CU49	◆ Khaki	LN20	◆ Mist	SRT45
		◆ Fog	CU03	◆ Sheen	LN10	◆ Mushroom	SRT76
		◆ Frost	CU22	◆ Slate	LN35	◆ Oyster	SRT18
		◆ Goldenrod	CU27	◆ Umber	LN25	◆ Reef	SRT64
		◆ Indigo	CU06	◆ Urban	LN30	◆ Sesame	SRT93
		◆ Iris	CU50			◆ Shale	SRT52
		◆ Iron Ore	CU19	LUCY*		TEMPEST*	
		◆ Jade	CU83	LC		TP	
		◆ Marsala	CU63	◆ Aspen	LC32	◆ Dragonfly	TP30
		◆ Morel	CU24	◆ Cornsilk	LC30	◆ Frost	TP15
		◆ Navy	CU98	◆ Dusk	LC22	◆ Full Stream	TP80
		◆ Peacock	CU97	◆ Fawn	LC33	◆ Gold Rush	TP10
		◆ Pear	CU84	◆ Graphite	LC34	◆ Slate	TP45
		◆ Ruby	CU67	◆ Mist	LC20	◆ Tumbleweed	TP70
		◆ Sapphire	CU09	◆ Neutra	LC24	◆ Wind Chill	TP40
				◆ Pewter	LC35	◆ Zebra	TP35
				◆ Snowdrop	LC28		

NOTES: Centurion fabrics not available on panels that exceed a width and height of 54"H.

Exchange is applied pattern cut and is not available on 78"W tackboards, Voi® screens, and Empower®.

Disperse is applied pattern cut and is not available on 72"W Accelerate® panels and not available on 66"W tackboards, Voi® screens, and Empower®.

◆◆◆ For lead time information see page 19.

* Directional fabrics

PANEL FABRIC PATTERNS & CODES

PRICE CODE B

ANALOG	ANLG
<i>Not available on Accelerate®</i>	
◆ Album	ANLG06
◆ Cartridge	ANLG04
◆ Cassette	ANLG09
◆ Dial	ANLG02
◆ Media	ANLG08
◆ Reel	ANLG07
◆ Signal	ANLG03
◆ Stereo	ANLG01
◆ Track	ANLG05

COAST*	COA
<i>Not available on Accelerate®</i>	
◆ Channel	COA14
◆ Dune	COA03
◆ Headlands	COA10
◆ Marsh	COA02
◆ Pebble	COA12
◆ Pier	COA13
◆ Shoal	COA01
◆ Silt	COA06
◆ Tide	COA08

PRICE CODE B *continued*

DISPERSE*	DISP
◆ Autumn	DISP03
◆ Branch	DISP10
◆ Coffee Bean	DISP13
◆ Dusk	DISP09
◆ Emerald City	DISP08
◆ Gold Rush	DISP02
◆ Igloo	DISP11
◆ Ink	DISP06
◆ Mist	DISP12
◆ Oatmeal	DISP15
◆ Prince	DISP07
◆ Reservoir	DISP01
◆ Rose	DISP04
◆ Spring	DISP05
◆ Steel	DISP16
◆ Taupe	DISP14

MICA*	MCA
◆ Anthracite	MCA11
◆ Breeze	MCA18
◆ Bronze	MCA13
◆ Buff	MCA14
◆ Cremini	MCA17
◆ Crystal	MCAWIT
◆ Dew	MCA20
◆ Dove	MCA12
◆ Fresh	MCA16
◆ Mineral	MCA15
◆ Nectar	MCA19
◆ Shale	MCA10

PRICE CODE B *continued*

SPIN*	SPIN
◆ Alabaster	SPIN02
◆ Cavern	SPIN03
◆ Cobblestone	SPIN04
◆ Ember	SPIN06
◆ Flame	SPIN07
◆ Heron	SPIN13
◆ Oat	SPIN01
◆ Ocean	SPIN12
◆ Plum	SPIN15
◆ Pool	SPIN11
◆ Raven	SPIN10
◆ Rhubarb	SPIN14
◆ Tropic	SPIN08
◆ Willow	SPIN05

TERRAIN*	TRRN
◆ Bay	TRRN05
◆ Bayou	TRRN35
◆ Canyon	TRRN30
◆ Cliff	TRRN45
◆ Crest	TRRN25
◆ Delta	TRRN10
◆ Plateau	TRRN15
◆ Ridge	TRRN20
◆ Valley	TRRN40

NOTES: Exchange is applied pattern cut and is not available on 78"W tackboards, Voi® screens, and Empower®.

Disperse is applied pattern cut and is not available on 72"W Accelerate® panels and not available on 66"W tackboards, Voi® screens, and Empower®.

◆◆◆ For lead time information see page 19.

* Directional fabrics

FEATURES OFFERED ON HON LAMINATE CASEGOODS

	10500	10700	Valido	Concinnity	94000	Voi
Worksurfaces						
• Scratch, stain and spill-resistant surface over durable 1/4" solid core high performance particleboard	•	•		•		•
• Scratch, stain and spill-resistant surface over extra-thick 1/2" solid core high performance particleboard			•			
• Scratch, stain and spill-resistant high gloss surface over durable 1/4" solid core high performance particleboard					•	
• Contoured hardwood accent trim		•			•	
• User-friendly waterfall-shaped edges and rounded corners improves worker comfort		•				
• Edge profile options				•		
Chassis Construction						
• European-designed fastening system – Precision, metal-to-metal, fasteners eliminate need for external cleats or exposed screws; enables tops or end panels to be interchanged or replaced	•	•	•	•	•	•
• Inner frame constructed using mortise and tenon joinery for superior structural strength and precisely positioning/securing the pedestal to the modesty panel; endures frequent moving/handling; ensures a longer product life cycle	•	•	•		•	
• All fasteners and dowels are positioned by computer to maintain rigorous dimensional standards	•	•	•	•	•	•
• End panels on base units and stack-ons feature PVC bottom edgebanding for added strength and to seal out moisture	•	•	•	•	•	•
Drawer Construction						
• Steel ball-bearing drawer suspensions for smooth, quiet, long-lasting operation	•	•	•	•	•	•
• 5-sided drawer construction for added strength and easy alignment or replacement of drawer fronts	•	•	•	•	•	•
• Full extension box and file drawers	•	•	•	•	•	•
• Hangrails provided in all file drawers for side-to-side letter, legal, A4 or EDP filing; and front-to-back for letter filing	•	•	•	•	•	•
Amenities						
• Conference overhang (select models) provides visitor's kneespace on approach side of desk for meetings	•	•	•	•	•	•
• Formal, full height modesty panels	•	•	•	•	•	•
• Short modesty panel option for easy access to wall electrical outlets	•	•	•	•		•
• Patented, side-mounted drawer handles provide good ergonomics and clean appearance	•	•				
• Antique brass drawer handles					•	
• Decorative drawer/door handle design and finish options			•	•		•
• Vertical grain direction on drawer fronts and modesty panels				•	•	•
• Upscale mixed material door options (select models) on overhead storage	•	•	•	•	•	•
• Adjustable hex leveling glides to level furniture without lifting	•	•	•	•	•	•
• Pullout reference/writing shelf provides additional worksurface space					•	
• Interchangeable lock cores (allow multiple units to be keyed alike)	•	•	•	•	•	•
• Central locking on desks (one lock secures all drawers)					•	
• Cord management (standard) to route and hide wires and cables	•	•	•	•	•	
• Cord management options on modular components (worksurfaces, end and modesty panels, pedestals)				•		•
Configuration Options						
• Components for efficient "U" and "L" shaped workstation layouts	•	•	•	•	•	•
• Peninsulas and corner units	•	•	•	•		
• Worksurfaces or shells up to 96"W	•			•		
• Standing, 42"H desking solutions	•			•		•
• Overheads sized to span multiple base units	•	•	•	•	•	•
• Reception station/transaction counter	•	•	•	•	•	
• Light scale styling, including worksurface components with O-leg supports	•			•		•
• Two-tone color options	•		•	•		•
Storage Options						
• 3/4 pedestals provide increased budget flexibility	•	•	•			
• Full desktop-to-floor pedestals maximize storage space	•	•	•	•	•	•
• Modular components/storage with precise, custom cabinet-like fits				•		•
• Modular shells w/ a variety of storage-pedestal solutions	•	•	•			
• Back wall storage in conventional (65") and executive (78") heights				•		
• Overheads, storage cabinets, wardrobes, lateral files, and bookcases	•	•	•	•	•	•
Companion Products						
• Matching conference tables	•			•	•	•
• Coordinating conference tables		•	•			
Endorsements						
• Meets or exceeds current ANSI/BIFMA and ISTA standards	•	•	•	•	•	•
• Meets SCS Indoor Advantage Certification (see page 17)	•	•	•	•	•	•
• level® certified in conformance with the BIFMA e3 furniture sustainability standard	•	•	•	•	•	•

CONCINNITY™



Concinnity™ Executive Workstation shown with Ignition® and Grove® Seating and Flock® Tables.

CONCINNITY™

Clean styling. Rich woodgrains. Mixed materials. A coordinated suite of components. With Concinnity, you can create an upscale look for all types of office spaces — from open to collaborative to private. Choose from a variety of desk configurations and an extensive selection of storage options to create the ideal solution to fit your footprint and your needs.



FEATURES

- Cohesive visual signature highlighted by clean lines, vertical grain, and components that fit together like custom cabinetry.
- Modular design delivers an unbeatable combination of versatility, style, and personalization to any workspace.
- Wide array of aesthetic options, including edge profiles, handles, mixed materials, and laminate finish combinations.
- Extensive assortment of storage solutions allow users to increase functionality, maximize space and keep everything conveniently within reach.
- Products to create flat, continuous horizontal planes or multi-level, overlapping, layered surfaces.
- Standing-height workstations to support today's healthy work styles; available with adjustable or fixed height bases.

CONCINNITY™ ORDERING INFORMATION

WORKSURFACES

L1 LAMINATES CODES

Woodgrain

- ◆ Bourbon Cherry H
- ◆ Cognac COGN
- ◆ Florence Walnut LFW1
- ◆ Harvest C
- ◆ Kingswood Walnut LK11
- ◆ Mahogany N
- ◆ Mocha MOCH
- ◆ Natural Maple D
- ◆ Pinnacle PINC
- ◆ Shaker Cherry F
- ◆ Sterling Ash LSA1

Solid

- ◆ Black P
- ◆ Charcoal S
- ◆ Designer White LDW1
- ◆ Loft LOFT

Patterned

- ◆ Sheer Mesh A5
- ◆ Silver Mesh B9

L2 LAMINATES CODES

Woodgrain

- ◆ Lowell Ash LLA1
- ◆ Natural Recon LNRI
- ◆ Phantom Ecru LPE1
- ◆ Portico Teak LPT1
- ◆ Skyline Walnut LSW1

DRAWER AND DOOR FRONTS

L1 LAMINATES CODES

Woodgrain

- ◆ Bourbon Cherry H
- ◆ Cognac COGN
- ◆ Florence Walnut LFW1
- ◆ Harvest C
- ◆ Kingswood Walnut LK11
- ◆ Mahogany N
- ◆ Mocha MOCH
- ◆ Natural Maple D
- ◆ Pinnacle PINC
- ◆ Shaker Cherry F
- ◆ Sterling Ash LSA1

Solid

- ◆ Black P
- ◆ Charcoal S
- ◆ Designer White LDW1
- ◆ Loft LOFT

L2 LAMINATES CODES

Woodgrain

- ◆ Lowell Ash LLA1
- ◆ Natural Recon LNRI
- ◆ Phantom Ecru LPE1
- ◆ Portico Teak LPT1
- ◆ Skyline Walnut LSW1

HANDLE/LOCK

FINISHES CODES

P1

- ◆ Black P
- ◆ Satin SA

CHASSIS, END, MODESTY, AND BACK PANELS

L1 LAMINATES CODES

Woodgrain

- ◆ Bourbon Cherry H
- ◆ Cognac COGN
- ◆ Florence Walnut LFW1
- ◆ Harvest C
- ◆ Kingswood Walnut LK11
- ◆ Mahogany N
- ◆ Mocha MOCH
- ◆ Natural Maple D
- ◆ Pinnacle PINC
- ◆ Shaker Cherry F
- ◆ Sterling Ash LSA1

Solid

- ◆ Black P
- ◆ Charcoal S
- ◆ Designer White LDW1
- ◆ Loft LOFT

L2 LAMINATES CODES

Woodgrain

- ◆ Lowell Ash LLA1
- ◆ Natural Recon LNRI
- ◆ Phantom Ecru LPE1
- ◆ Portico Teak LPT1
- ◆ Skyline Walnut LSW1

HMBPOST AND HMBTLEG24

PAINTS CODES

P1

- ◆ Black P

P2

- ◆ Platinum Metallic T1

SILVER COLORWAY: The following finish options are coordinating silver colorways — Satin, Satin Nickel, Matte Chrome, Platinum, and Platinum Metallic.

EDGE PROFILES “B” AND “V”

EDGEBAND COLORS CODES

Woodgrain

- ◆ Bourbon Cherry H
- ◆ Cognac COGN
- ◆ Florence Walnut FW
- ◆ Harvest C
- ◆ Kingswood Walnut KI
- ◆ Mahogany N
- ◆ Mocha MOCH
- ◆ Natural Maple D
- ◆ Pinnacle PINC
- ◆ Shaker Cherry F
- ◆ Sterling Ash SA

EDGE PROFILE “G”

EDGEBAND COLORS CODES

Woodgrain

- ◆ Bourbon Cherry H
- ◆ Cognac COGN
- ◆ Florence Walnut FW
- ◆ Harvest C
- ◆ Kingswood Walnut KI
- ◆ Lowell Ash DL
- ◆ Mahogany N
- ◆ Mocha MOCH
- ◆ Natural Maple D
- ◆ Natural Recon NR
- ◆ Phantom Ecru PE
- ◆ Pinnacle PINC
- ◆ Portico Teak DP
- ◆ Shaker Cherry F
- ◆ Skyline Walnut SW
- ◆ Sterling Ash SA

Solid

- ◆ Black P
- ◆ Charcoal S
- ◆ Designer White DW
- ◆ Loft LOFT

Pattern laminates do not have a matching edgeband color; they are available with a woodgrain or solid color edge.

◆◆◆ For lead time information see page 19.

CONCINNITY™ ORDERING SPECIFICATION/MODEL LOGIC

DESKS	
Double Pedestal Desk	Model Edge Profile + Edge Color Handle Worksurface Grommet Finish Worksurface Color Chassis Color Drawer Front Color
Single Pedestal Desk (Left & Right)	Model Edge Profile + Edge Color Handle Worksurface Grommet Finish Worksurface Color Chassis Color Drawer Front Color
CREDENZAS	
Credenza w/ Storage	Model Edge Profile + Edge Color Handle Worksurface Grommet Finish Worksurface Color Chassis Color Drawer/Door Front Color
Credenza w/ Kneespace	Model Edge Profile + Edge Color Handle Worksurface Grommet Finish Worksurface Color Chassis Color Drawer Front Color
Credenza w/ Lateral File (Left & Right)	Model Edge Profile + Edge Color Handle Worksurface Grommet Finish Worksurface Color Chassis Color Drawer Front Color
Single Pedestal Credenza (Left & Right)	Model Edge Profile + Edge Color Handle Worksurface Grommet Finish Worksurface Color Chassis Color Drawer Front Color
Credenzas - Low/Bench-Height	Model Edge Profile + Edge Color Handle Top Color Chassis Color Drawer Front Color
RETURNS	
Return (Left & Right)	Model Edge Profile + Edge Color Handle Worksurface Grommet Finish Worksurface Color Chassis Color Drawer Front Color
BULLET PENINSULA	
Bullet Peninsula	Model Edge Profile + Edge Color Worksurface Color Chassis Color
BRIDGES	
Bridge	Model Edge Profile + Edge Color Worksurface Grommet Finish Worksurface Color Chassis Color
CORNER UNITS	
Corner Unit	Model Edge Profile + Edge Color Worksurface Grommet Finish Worksurface Color Chassis Color
JETTY PENINSULAS	
Jetty Peninsula	Model Edge Profile + Edge Color Worksurface Grommet Finish Worksurface Color Chassis Color
STACK-ON STORAGE	
Stack-On Storage w/ Laminate Doors	Model Chassis Color Door Front Color
Stack-On Storage w/ Laminate Locking Doors	Model Lock Finish Chassis Color Door Front Color
Stack-On Storage w/ Frosted Doors	Model Chassis Color
Stack-On Storage w/ Sliding Door	Model Chassis Color Door Front Color
Stack-On Space Saver End Panels	Model Laminate Color
WALL MOUNTED STORAGE	
Wall Mounted Storage w/ Laminate Doors	Model Chassis Color Door Front Color
Wall Mounted Storage w/ Laminate Locking Doors	Model Lock Finish Chassis Color Door Front Color
Wall Mounted Storage w/ Frosted Doors	Model Chassis Color
Wall Mounted Storage w/ Sliding Door	Model Chassis Color Door Front Color
BOOKCASE HUTCHES	
Bookcase Hutch - No Doors/Open	Model Laminate Color
Bookcase Hutch w/ Laminate Doors	Model Handle Chassis Color Door Front Color
Bookcase Hutch w/ Frosted Doors	Model Laminate Color
RECEPTION STATIONS	
Reception Station	Model Edge Profile Edge Color Counter Color Chassis Color
Reception Station Counter	Model Edge Profile + Edge Color Counter Color Chassis Color
L-Reception Station Counter	Model Edge Profile + Edge Color Counter Color Chassis Color
Reception Desk with Transaction Counter	Model Edge Profile + Edge Color Worksurface Grommet Color Worksurface Color Chassis Color Accent Color
Reception Return with Transaction Counter	Model Edge Profile + Edge Color Worksurface Color Chassis Color
L-Reception Station with Transaction Counter	Model Edge Profile + Edge Color Counter Color Chassis Color
Transaction Counter Organizer	Model Edge Profile + Edge Color Counter Color Chassis Color
LATERAL FILES & STORAGE CABINETS	
Lateral File	Model Edge Profile + Edge Color Handle Top Color Chassis Color Drawer Front Color
Storage Cabinet - 78 $\frac{1}{8}$ " and 64 $\frac{3}{4}$ "H	Model Handle Chassis Color Door Front Color
Storage Cabinet - 29 $\frac{1}{2}$ "H	Model Edge Profile + Edge Color Handle Top Color Chassis Color Door Front Color
Storage/File Cabinet - No Doors/Open	Model Handle Chassis Color Drawer Front Color
Storage/File Cabinet w/ Laminate Door	Model Handle Chassis Color Door & Drawer Front Color
Storage Cabinet/Lateral File	Model Handle Chassis Color Door & Drawer Front Color

CONCINNITY™ ORDERING SPECIFICATION/MODEL LOGIC

WARDROBES	
Wardrobe/Storage Cabinet	Model Handle Chassis Color Door Front Color
Wardrobe/Bookcase	Model Handle Chassis Color Door Front Color
STORAGE TOWERS	
24"W Storage Tower	Model Handle Chassis Color Door & Drawer Front Color
18"W Storage Tower	Model Handle Chassis Color Door Front Color
BOOKCASES	
Bookcase	Model Edge Profile and Edge Color Top Color Chassis Color
Bookcase w/ Coat Hooks	Model Laminate Color
WORKSURFACES	
Rectangle Worksurface	Model Edge Profile + Edge Color Grommet Worksurface Color
Bow Worksurface	Model Edge Profile + Edge Color Grommet Worksurface Color
Bullet Worksurface	Model Edge Profile + Edge Color Grommet Worksurface Color
Extended Corner Worksurface	Model Edge Profile + Edge Color Worksurface Grommet Worksurface Color End Panel Color
PANELS & LEGS	
27 ⁷ / ₈ "H Modesty/Back Panel	Model Grommet Laminate Color
10"H Modesty/Back Panel	Model Laminate Color
10"H Modesty Panel for Desks with O-Legs	Model Laminate Color
14"H Floating Modesty Panel	Model Laminate Color or Mixed Material
Half-Height Modesty Panel	Model Laminate Color
Full-Height Modesty Panel	Model Laminate Color
Full Back Panel for Pedestals - 30" & 36"W x 27 ⁷ / ₈ "H	Model Grommet Laminate Color
Full Back Panel for Pedestals - 9 ¹ / ₂ ", 15 ³ / ₄ ", & 18"W	Model Laminate Color
Full Back Panel for Pedestals - 9 ¹ / ₂ " & 15 ³ / ₄ "W x 40 ³ / ₈ "H	Model Laminate Color
Low Back Panel for Pedestal	Model Laminate Color
Laminate End Panel - 1 ¹ / ₈ "W x 28 ¹ / ₂ " or 41"H	Model Grommet Laminate Color
Laminate End Panel - 1 ¹ / ₈ "W x 7"H	Model Laminate Color
Laminate End Panel - L-Shape	Model Grommet Laminate Color
Laminate End Panel - T-Shape	Model Laminate Color
Laminate End Panel - Kneespace Clearance	Model Laminate Color
Laminate End Panel - Support Brace	Model Laminate Color
Metal O-Leg	Model Paint Color
PEDESTALS	
Pedestal - Narrow Box/Box/File	Model Handle Grommet Chassis Color Drawer Front Color
Pedestal - Narrow File/File	Model Handle Grommet Chassis Color Drawer Front Color
Pedestal - Box/Box/File	Model Handle Grommet Chassis Color Drawer Front Color
Pedestal - File/File	Model Handle Grommet Chassis Color Drawer Front Color
Pedestal - Lateral File	Model Handle Grommet Chassis Color Drawer Front Color
Pedestal - Shelf/Box/Box/Lateral File	Model Handle Grommet Chassis Color Drawer Front Color
Pedestal - Storage Cabinet	Model Handle Grommet Chassis Color Door Front Color
Pedestal - Bookcase	Model Grommet Chassis Color
Pedestal - Bookcase End Support	Model Chassis Color
Mobile Pedestal - Box/Box/File, File/File, Box/File	Model Handle Chassis Color Drawer Front Color
Mobile Pedestal - 30"W Shelf/File/Cabinet	Model Edge Profile + Edge Color Handle Top Color Chassis Color Drawer/Door Front Color
Pedestal Tops	Model Edge Profile + Edge Color Top Color
Pedestal - Box/Box/File/File	Model Handle Grommet Chassis Color Drawer Front Color
Pedestal - Shelf/Box/Box/File	Model Handle Grommet Chassis Color Drawer Front Color
Pedestal - Narrow Box/Box/File/File	Model Handle Grommet Chassis Color Drawer Front Color
ACCESSORIES	
Laminate Center Drawer	Model Laminate Color
Collaborative Desk Shelf	Model Laminate Color
Wall Mount Markerboard	Model
Wall Mount Tackboard	Model Fabric
Field Installable Grommet	Model
Lock Core Kit	Model

CONCINNITY™ LAMINATE DESIGN/MATERIALS INFORMATION

STYLING AND CONSTRUCTION

- Conventional desking or light scale components.
- Clean, uninterrupted lines and precise fits; no gaps.
- All end, modesty, and back panels, as well as drawer and door fronts, that are specified in a woodgrain color, feature vertical grain; drawer fronts are vertically-aligned, continuous grain and are matched sets.
 - Modesty panels wider than 60" have horizontal grain on L2 and non-standard finishes.
- All desk, credenza, and return models feature full-to-the-floor pedestals to maximize storage space.
- Factory-configured (i.e., built-up; assembled) 72"W desks can be specified with breakfront or recessed modesty panels.
- Formal, full height modesty panels on factory-configured (i.e., built-up; assembled) desks, credenzas, and returns; modular components available with full or 10" modesty panels.
- Drawer and door fronts over end panels.
- Back panel-over-end panel on desks, credenzas, returns, mobile pedestals, 29½"H lateral files and storage cabinets, and full-length modesty panels for modular pedestals.
- Top-between-end panels on stack-on and wall mount storage, 66⅝"H & 79½"H storage and combination storage cabinets, wardrobes and towers.
- Option choices include:
 - Edge profile and edge color
 - Handle design
 - Handle/worksurface grommet/lock face finish
 - Worksurface color
 - Chassis color
 - Drawer front/door color
- **IMPORTANT NOTE:** Designed and sized to coordinate with 65"H Accelerate® Panels.
 - Desks, credenzas, returns, 2-drawer lateral files, and 29½"H storage cabinets, plus 35¼"H stack-on storage or bookcase hutch, are 64¾"H.
 - Additional solutions ≤65"H include the following: storage cabinet, storage/file cabinet, storage cabinet/lateral file, 18" and 36"W wardrobe/storage cabinets, wardrobe/bookcase, storage tower, and 5-shelf bookcase.

MATERIALS

- Easy-care, scratch-, spill- and stain-resistant thermal-fused laminate (TFL) over solid core, high performance particleboard;
 - Component model thickness: 1⅛" worksurfaces and end panels; ¾" modesty panel and drawer/door fronts.

- Durable, impact-resistant banding protects edges.
- Bottom of end panels on base units and stack-ons feature edgebanding for added strength and to seal out moisture.
- HPL worksurfaces are available via special request.

DRAWER SPECIFICATIONS

- Operate on steel ball-bearing slides to ensure smooth, quiet, long-lasting operation.
- Full extension drawers allow complete access to contents.
- Drawers feature 5-sided construction for added strength and easy alignment or replacement of drawer fronts.
- File drawers include integrated hangrails for side-to-side letter or legal filing; and front-to-back for letter filing.
- One molded black pencil tray is included in each box/box/file pedestal.
- Drawer fronts are edgebanded on all four sides.

CORE REMOVABLE LOCKS

- All drawers/doors lock on the following products:
 - All desk, credenza, and return pedestals (NOTE: The lock is on the face of the pedestal)
 - Stack-on and wall mount storage with laminate locking doors ("LL" models)
 - Wall mount storage with sliding door
 - Mobile pedestals
 - Lateral files
 - Storage cabinets
 - Storage/file cabinet
 - Storage cabinet/lateral file
 - Wardrobe/storage cabinets
 - Storage towers
 - Modular pedestals
- On products that are equipped with two locks, the locks are keyed alike:
 - Double pedestal desks
 - Credenza with storage
 - Credenzas with kneespace
 - Low credenzas with four drawers
 - Storage and combination storage/file cabinets
 - Storage towers
 - Stack-on and wall mount storage 60" - 78"W
- Lock faces are available in black or satin.

CONCINNITY™ LAMINATE DESIGN/MATERIALS INFORMATION

- Locks feature a removable cylinder (core) that can be interchanged as needed; allows all furniture pieces within an individual workstation to be accessed with one key for convenience, and allows locks to be differentiated between workstations and offices for security. Makes re-keying quick and easy.
 - Keyed alike cores must be ordered separately by specification of the key number. For all products, except stack-on and wall mounted storage, the removable lock core kits are HF23B for Black and HF23S for Satin (Silver).
 - EXCEPTION - IMPORTANT - NOTE: The removable lock core kit for stack-on and wall mounted storage is model HF27B (Black) or HF27S (Satin).

CORD MANAGEMENT

- Cord management grommets and pass-through cutouts, for routing and hiding wires and cables, are standard in a pre-determined location on a number of factory-configured (i.e., built-up; assembled) products:
 - Two grommets are located in the tops of desks and credenzas; one grommet is located in the top of returns, bridges, jetty peninsulas, and corner units.
 - All desk, credenza, and return pedestals are designed with two cord pass-through grommets, one per side; end panels of single pedestal desks and single pedestal credenzas feature one cord pass-through grommet.
 - Pass-through in the sides of pedestals and end panels enable the routing of cords below the worksurface and connections between workstations.
 - A pass-through grommet, to facilitate reaching wall electrical outlets, is located in the back panels of credenza with storage, credenza with kneespace, single pedestal credenzas, credenzas with 36" lateral file, returns and bridges.
- See chart on page 36 for cord management options. Worksurfaces/tops, end and modesty panels, and pedestals can be specified with or without grommets.
- Grommets on worksurfaces are sized to accept optional grommet mount power hub (HGRMTAC) and USB (HGRMTUSB2) models.

- Grommet color/shape/size:
 - Worksurfaces, Black or Platinum, Round, 3" diameter hole with a 3½" plastic cap.
 - Back/modesty panels, Black, Round, 2½" diameter hole with a 3" plastic cap.
 - End panels and pedestal sides, Black, Half-round, 1¾" diameter hole with a 2" x 2½" plastic cap.

LEVELING GLIDES

- Adjustable hex glides to compensate for uneven floors; allow furniture to be easily leveled without lifting the unit.
 - Glides have a 1¼" adjustable range.
 - The hex adjustment is on the foot of the glide for all products except for the 9½", 15¾", and 18"W modular pedestals, in which case it is on the top of the glide stem.







IMPORTANT — OTHER

- Products ship fully assembled, unless otherwise noted (NOTE:  — easy-to-assemble — items are designated in the "DESCRIPTIONS").
- All models must meet or exceed ANSI/BIFMA & ISTA performance standards.
- Products covered by HON Limited Lifetime Warranty.
- Indoor Advantage™ Gold. Indoor Air Quality Certified to SCS-EC10.3-2014 v3.0.
- BIFMA level® 2 certified. Conforms to ANSI/BIFMA e32014e Furniture Sustainability Standard.

CONCINNITY™ LAMINATE ORDERING/SPECIFICATION INFORMATION

WORKSURFACE/TOP EDGE DETAILS

- Three options; two contoured profiles and one smooth, flat edge.
- For beaded (B) and tri-oval (V) edge shapes, tops are profiled on the user and approach sides, and flat on the ends; the flat edges allow side-by-side placement of worksurfaces without gaps. The only exceptions are return, bridge, corner unit, extended corner worksurface, and rectangle worksurface with vertical grain models, tops on these items are profiled on the user's side and flat banded on the approach side and ends.
 - Bookcases have profiled edge on the front, user side only.
 - The reception station transaction counter and the L-reception station with transaction counter (for the desk) models, have profiled edgeband on the approach and user sides.
 - The L-reception station with the transaction counter models, on which the counter runs around the entire perimeter of the L-configuration, have a profiled edge on the front of the transaction counter on the desk approach side only.

Edge Options:	Profiles	Designator	
Beaded			B
Smooth, Flat			G
Tri-Oval			V

WORKSURFACE EDGE COLORS

- Woodgrain and solid color laminates can be specified with a matching, complementary, or contrasting edgeband color; options include:
 - Matching the worksurface edge to a common worksurface, chassis, and drawer front color.
 - Matching the worksurface edge to the worksurface laminate and selecting a different laminate color for the chassis.
 - Matching the worksurface edge to the chassis laminate and selecting a different laminate color for the worksurface.

- Beaded (B) and tri-oval (V) edges are available in L1 woodgrain colors only.
- The smooth, flat (G) edge is available in woodgrain and solid colors.
- Pattern laminates do not have a matching edgeband color; the patterns are available with a woodgrain or solid color edge.

DRAWER/DOOR DECORATIVE HANDLES

- Three handle style options, each available in Satin or Black finish.
- Distinct, easy to grasp designs.
- Handles are metal.
- The hole spacing is 128mm.
- The handle style/finish has to be specified on drawer fronts (desk/credenza/return, mobile and modular pedestals), lateral file drawer fronts, the doors of the storage cabinet, storage/file cabinet, storage cabinet/lateral file, wardrobe/storage cabinet, wardrobe/bookcase, and storage tower.
 - NOTE: Decorative handles are not used on the doors of stack-on storage units or wall mounted storage cabinets.
 - Bookcase hutches with frosted doors are equipped with a push latch release.

Handle Options	Finish	Designator
Cylinder	Satin	A
Cylinder	Black	B
Canopy	Satin	C
Canopy	Black	D
Loop	Satin	E
Loop	Black	F

- NOTE: The Linear and Arch field installable drawer/door handle kit models can be attached using 128mm hole spacing.

CONCINNITY™

LAMINATE ORDERING/SPECIFICATION INFORMATION

CORD MANAGEMENT GROMMETS

- Grommets are standard on desk, credenza, return, bridge, jetty peninsula, and corner unit models. Specification logic includes the grommet finish for tops; choose from Black (P) or Platinum (T1). Grommets in modesty and end panels are Black only.
- Grommets are optional on modular component worksurfaces, full-length (27⁷/₈"H) modesty panels, end panels (1¹/₈", L-shaped) and the sides of support storage pedestals. On worksurfaces, choose from Black (P), Platinum (T1), or no grommet(s) (X). On modesty, end, and side panels the options are grommet Black (P) or no grommet (X).
- See cord management chart on page 36 for details.

LOCK FINISH

- Finish is determined by, and automatically aligned with, the handle finish specified. If there is no decorative handle on the product, such as on locking stack-on or wall mount storage models, the lock finish is specified separately in the option string.
 - When specification is required, the lock finish options are Black (P) or Satin (SA).
- Removable, interchangeable lock core kits must be ordered separately:
 - For all models, except stack-on and wall mount storage, specify model HF23B (Black) or HF23S (Satin), and the specific key number required.
 - For stack-on and wall mount storage, specify model HF27B (Black) or HF27S (Satin), and the specific key number required.

SILVER COLORWAY

- The following finish options are coordinating Silver colorways: Satin, Satin Nickel, Matte Chrome, Platinum, and Platinum Metallic.

LAMINATE COLORS

- Palette choices include eight (15) woodgrain, four (4) solid, and two (2) pattern colors.

Woodgrain		Solid Color		Pattern	
Bourbon Cherry	H	Black	P	Sheer Mesh	A5
Cognac	COGN	Charcoal	S	Silver Mesh	B9
Florence Walnut	LFW1	Designer White	LDW1		
Harvest	C	Loft	LOFT		
Kingswood Walnut	LK11				
Lowell Ash	LLA1				
Mahogany	N				
Mocha	MOCH				
Natural Maple	D				
Natural Recon	LNR1				
Phantom Ecru	LPE1				
Pinnacle	PINC				
Portico Teak	LPT1				
Shaker Cherry	F				
Skyline Walnut	LSW1				
Sterling Ash	LSA1				

- Worksurface, chassis and drawer/door fronts are specified separately to enable a single, color-matched visual, or a complementary or contrasting, multi-tone aesthetic.
- Worksurfaces/tops are available in woodgrain, solid, or pattern laminate colors.
- Chassis and drawer fronts are available in woodgrain or solid laminate colors.
- Pattern colors are available on worksurface tops only.

Worksurface		Chassis		Drawer/Door	
Bourbon Cherry	H	Bourbon Cherry	H	Bourbon Cherry	H
Cognac	COGN	Cognac	COGN	Cognac	COGN
Florence Walnut	LFW1	Florence Walnut	LFW1	Florence Walnut	LFW1
Harvest	C	Harvest	C	Harvest	C
Kingswood Walnut	LK11	Kingswood Walnut	LK11	Kingswood Walnut	LK11
Lowell Ash	LLA1	Lowell Ash	LLA1	Lowell Ash	LLA1
Mahogany	N	Mahogany	N	Mahogany	N
Mocha	MOCH	Mocha	MOCH	Mocha	MOCH
Natural Maple	D	Natural Maple	D	Natural Maple	D
Natural Recon	LNR1	Natural Recon	LNR1	Natural Recon	LNR1
Phantom Ecru	LPE1	Phantom Ecru	LPE1	Phantom Ecru	LPE1
Pinnacle	PINC	Pinnacle	PINC	Pinnacle	PINC
Portico Teak	LPT1	Portico Teak	LPT1	Portico Teak	LPT1
Shaker Cherry	F	Shaker Cherry	F	Shaker Cherry	F
Skyline Walnut	LSW1	Skyline Walnut	LSW1	Skyline Walnut	LSW1
Sterling Ash	LSA1	Sterling Ash	LSA1	Sterling Ash	LSA1
Black	P	Black	P	Black	P
Charcoal	S	Charcoal	S	Charcoal	S
Designer White	LDW1	Designer White	LDW1	Designer White	LDW1
Loft	LOFT	Loft	LOFT	Loft	LOFT
Sheer Mesh	A5				
Silver Mesh	B9				

- Two-tone color options allow specification of different, complementary laminate combinations:

Color #1	Color #2
Top	Chassis and Drawer Fronts
Top and Drawer Fronts	Chassis
Top and Chassis	Drawer Fronts

- Modesty panels and the backs of storage chassis that are specified in L2 laminates and wider than 60"W will ship as horizontal grain.

CONCINNITY™ CORD MANAGEMENT

	GROMMET	# OF GROMMETS	LOCATION	CUTOUT SHAPE	MATERIAL	COLOR/FINISH
BUILT-UP/FACTORY-CONFIGURED						
DESK						
Top	Standard/Fixed Location	2	Back Left & Right	3" Round	Plastic	Black or Platinum
End Panel	Standard/Fixed Location	2 (1 per EP)	Top Back Corner	1¼" Round	Plastic	Black
Modesty/Back	Not Available	0	N/A	N/A	N/A	N/A
CREDENZA						
Top	Standard/Fixed Location	2	Back Left & Right	3" Round	Plastic	Black or Platinum
End Panel	Standard/Fixed Location	2 (1 per EP)	Top Back Corner	1¼" Round	Plastic	Black
Modesty/Back	Standard/Fixed Location	1	Top Center	2½" Round	Plastic	Black
RETURN						
Top	Standard/Fixed Location	1	Top Center	3" Round	Plastic	Black or Platinum
End Panel	Standard/Fixed Location	1	Top Back Corner	1¼" Round	Plastic	Black
Modesty/Back	Standard/Fixed Location	1	Top Center	2½" Round	Plastic	Black
BRIDGE						
Top	Standard/Fixed Location	1	Back Center	3" Round	Plastic	Black or Platinum
Modesty/Back	Standard/Fixed Location	1	Top Center	2½" Round	Plastic	Black
BULLET PENINSULA						
Top	Not Available	0				
End Panel	Not Available; Pass-Thru in Brace Panel	0				
JETTY PENINSULA						
Top	Standard/Fixed Location	1	Back, Approach-Side Corner	3" Round	Plastic	Black or Platinum
End Panel	Not Available; Pass-Thru Standard in Brace Panel	0				
CORNER UNIT						
Top	Standard/Fixed Location	1	Back Corner	3" Round	Plastic	Black or Platinum
Modesty/Back	Not Available; Pass-Thru Standard in Brace Panels	0				
Stack-on	Standard/Fixed Location	1	1¼" Side-to-Side Gap at Top or Bottom of Back Panel, Below Cabinet			
MODULAR COMPONENTS – WORKSURFACES						
Rectangle – 60" to 96"W	Optional – Specify: Black (P) or Platinum (T1) or None (X)	2	Back Left & Right	3" Round	Plastic	Black or Platinum
Rectangle – 30" to 54"W	Optional – Specify: Black (P) or Platinum (T1) or None (X)	1	Back Center	3" Round	Plastic	Black or Platinum
Bullet Shape	Optional – Specify: Black (P) or Platinum (T1) or None (X)	1	Centered Along EP; Over Brace Leg Cutout	3" Round	Plastic	Black or Platinum
Ext. Corner	Optional – Specify: Black (P) or Platinum (T1) or None (X)	1	Back Corner of Top and Long End Panel	3" Round	Plastic	Black or Platinum
MODULAR COMPONENTS – MODESTY PANELS						
Full-Length – ≥30"W	Optional – Specify: Black (P) or None (X)	1	Top Center	2½" Round	Plastic	Black
10"	No	0				
MODULAR COMPONENTS – END PANELS						
1½" Thick	Optional – Specify: Black (P) or None (X)	1	Top Back Corner	1¼" Round	Plastic	Black
T-Shaped	No	0				
L-Shaped	Optional – Specify: Black (P) or None (X)	1	Top or Bottom Centered	1¼" Round	Plastic	Black
MODULAR COMPONENTS – STORAGE PEDESTALS						
Pedestal	Optional – Specify: Black (P) or None (X)	2 (1 per EP)	Top Back Corner	1¼" Round	Plastic	Black

NOTE: If customer wants a desk, credenza, return, or bridge without grommets, they can specify modular components.

Grommet Locations in Tops

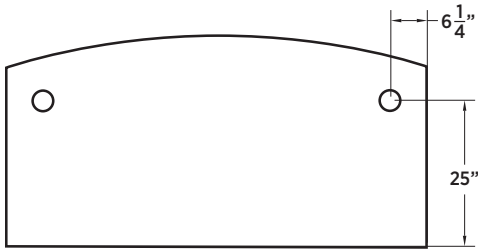

Bow Top Desks and Worksurfaces

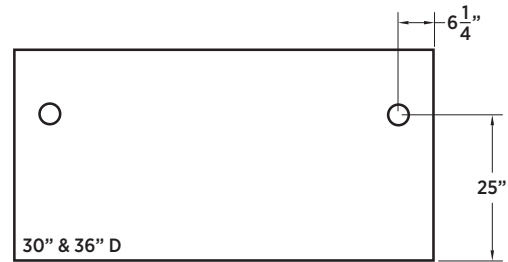

Desks and Rectangle Worksurfaces

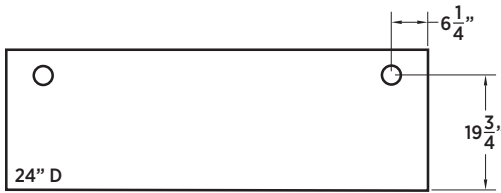

Credenzas and Rectangle Worksurfaces

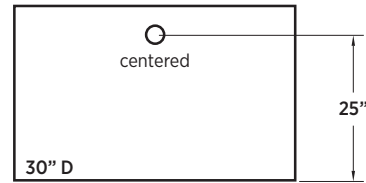

Rectangle Worksurfaces

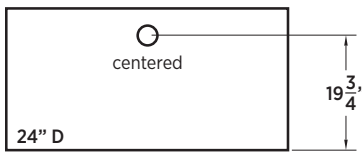

Returns, Bridges, and Rectangle Worksurfaces

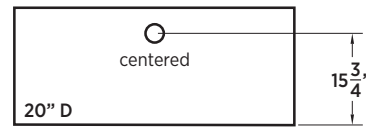

Rectangle Worksurfaces

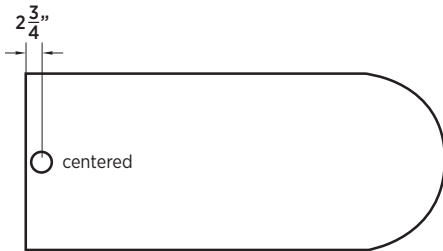

Bullet Worksurfaces

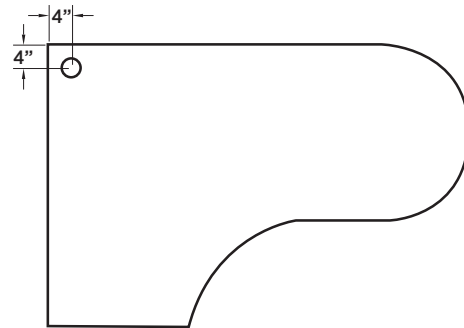

Jetty Peninsula

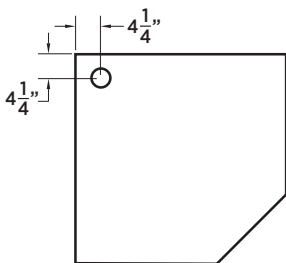

Corner Unit

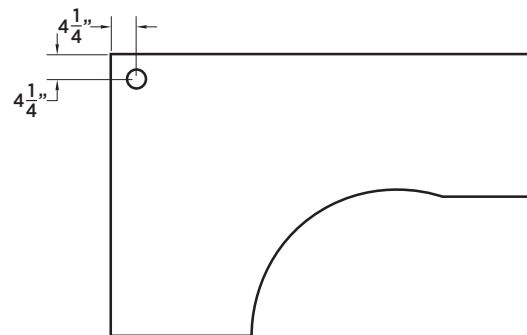

Extended Corner Worksurfaces

CONCINNITY™

Typicals



Icon Legend on page 19

QTY	DESCRIPTION	MODEL	LIST PRICE	PRICE EXTENSION
1	Double Pedestal Desk, Bow Top, Breakfront Frosted Modesty Panel 72"W x 36"D x 29½"H	HNL3672DPBBF	\$2,941	\$2,941
1	Credenza with Kneespace 72"W x 24"D x 29½"H	HNL2472DPK	\$1,855	\$1,855
1	Wall Mount Storage, Frosted Doors with Silver Frame 72"W x 15"D x 28½"H	HNL2972FD	\$2,432	\$2,432
1	Storage/File Cabinet, Hinged Right 18"W x 24"D x 64¾"H	HNL241865SFLR	\$1,775	\$1,775
1	Storage/File Cabinet, Hinged Left 18"W x 24"D x 64¾"H	HNL241865SFL	\$1,775	\$1,775
TOTAL:			\$10,778	

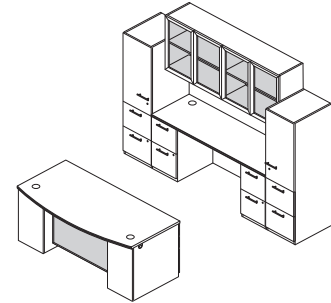
**DESK — CREDENZA — STORAGE**

QTY	DESCRIPTION	MODEL	LIST PRICE	PRICE EXTENSION
1	Left Pedestal Desk, Rectangle Top, Breakfront Modesty Panel 72"W x 36"D x 29½"H	HNL3672LPRB	\$1,949	\$1,949
1	Rectangle Worksurface with Vertical Grain 42"W x 24"D	HNLRC2442V	\$262	\$262
1	Narrow File/File Pedestal 9½"W x 23⅞"D x 28½"H	HNL231028PFF	\$705	\$705
1	Modesty/Back Panel — Full-Length 42"W x 27⅞"H	HNLMP4228	\$208	\$208
1	Stack-on Storage, Sliding Door 78"W x 15"D x 35¼"H	HNL3678SD	\$1,293	\$1,293
1	Storage/File Cabinet, Open Shelves 18"W x 24"D x 64¾"H	HNL241865SFX	\$1,685	\$1,685
TOTAL:			\$6,102	

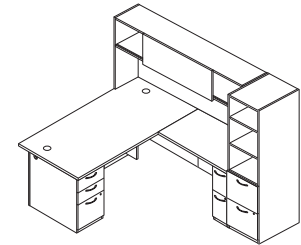
**L-WORKSTATION**

QTY	DESCRIPTION	MODEL	LIST PRICE	PRICE EXTENSION
1	Rectangle Worksurface 72"W x 30"D	HNLRC3072	\$438	\$438
1	Narrow Box/Box/File Pedestal 9½"W x 29⅞"D x 28½"H	HNL291028PBBF	\$787	\$787
1	Full Back Panel — For 9½"W Pedestal 9½"W x 27⅞"H	HNLPB1028	\$129	\$129
1	Laminate Floating Modesty Panel 36"W x 14"H	HLSL3614L	\$183	\$183
1	Bookcase End Support 12"W x 30"D x 28½"H	HNL123028BKE	\$518	\$518
1	Rectangle Worksurface 72"W x 24"D	HNLRC2472	\$374	\$374
1	Shelf/Box/Box/Lateral File Pedestal 36"W x 23⅞"D x 28½"H	HNL233628PSL	\$1,270	\$1,270
1	Storage Cabinet Pedestal 36"W x 23⅞"D x 28½"H	HNL233628PSC	\$826	\$826
1	Modesty/Back Panel — Full-Length 72"W x 27⅞"H	HNLMP7228	\$292	\$292
1	Stack-on Storage, Sliding Door 72"W x 15"D x 35¼"H	HNL3672SD	\$1,254	\$1,254
1	Bookcase with Coat Hooks, 5-Shelf, Left 24"W x 24"D x 64¾"H	HNL2424BK5CL	\$977	\$977
TOTAL:			\$7,048	

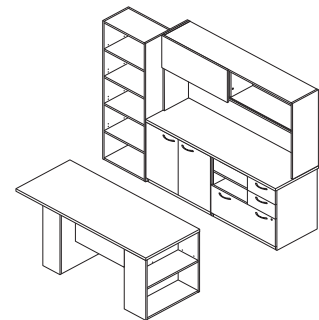
**DESK — CREDENZA — STORAGE**



Icon Legend on page 19

CONCINNITY™ Typicals

DESKS

QTY	DESCRIPTION	MODEL	LIST PRICE	PRICE EXTENSION
1	Rectangle Worksurface 60"W x 24"D	HNLRC2460	\$333	\$333
1	Height Adjustable Base	HHAB3S2L	\$1,120	\$1,120
1	Rectangle Worksurface 84"W x 24"D	HNLRC2484	\$503	\$503
1	End Panel, Left 1½"W x 23⅞"D x 28½"H	HNLEP2428L	\$208	\$208
1	Shelf/Box/Box/Lateral File Pedestal 36"W x 23⅞"D x 28½"H	HNL233628PSL	\$1,270	\$1,270
1	Modesty/Back Panel — Short 84"W x 10"H	HNLMP8410	\$355	\$355
1	Low Back Panel — For 28½"H Pedestal 36"W x 18"H	HNLB3618	\$152	\$152
2	Stack-on Storage, Frosted Doors with Silver Frame 42"W x 15"D x 35¼"H	HNL3642FD	\$1,353	\$2,706
1	Space Saver End Panels for Stack-on Storage ¾"W x 14¼"D x 35¼"H	HNL3605SSEP	\$388	\$388
1	Wardrobe/Storage Cabinet, Hinged Right 18"W x 24"D x 64¾"H	HNL241865WLR	\$1,622	\$1,622

TOTAL: \$8,657

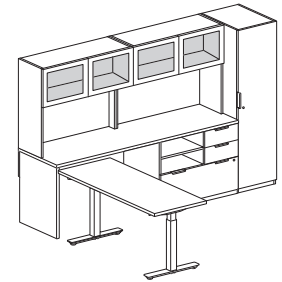

L-WORKSTATION WITH HEIGHT-ADJUSTABLE DESK — OPEN PLAN

QTY	DESCRIPTION	MODEL	LIST PRICE	PRICE EXTENSION
1	Bullet Worksurface 84"W x 30"D	HNLBU3084	\$615	\$615
1	T-Shaped End Panel — For Bullet Worksurface 11⅝"W x 29⅞"D x 28½"H	HNLTEP3028	\$360	\$360
1	Support Column — For Bullet Worksurface 3" Diameter	HPC190X	\$161	\$161
1	Bridge 48"W x 24"D x 29½"H	HNL2448BF	\$457	\$457
1	Rectangle Worksurface 84"W x 24"D	HNLRC2484	\$503	\$503
1	End Panel, Left 1½"W x 23⅞"D x 28½"H	HNLEP2428L	\$208	\$208
1	Shelf/Box/Box/Lateral File Pedestal 36"W x 23⅞"D x 28½"H	HNL233628PSL	\$1,270	\$1,270
1	Modesty/Back Panel — Full-Length 84"W x 27⅞"H	HNLMP8428	\$355	\$355
2	Stack-on Storage, Laminate Doors 42"W x 15"D x 48⅝"H	HNL4942LD	\$1,231	\$2,462
1	Space Saver End Panels for Stack-on Storage ¾"W x 14¼"D x 48⅝"H	HNL4905SSEP	\$523	\$523

TOTAL: \$6,914

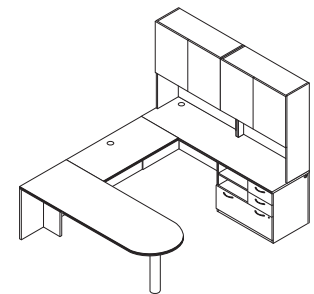

U-WORKSTATION WITH 84'W WORKSURFACE

QTY	DESCRIPTION	MODEL	LIST PRICE	PRICE EXTENSION
1	Left Pedestal Desk, Rectangle Top, Breakfront Frosted Modesty Panel 72"W x 36"D x 29½"H	HNL3672LPRBF	\$2,433	\$2,433
1	Rectangle Worksurface with Vertical Grain 48"W x 24"D	HNLRC2448V	\$280	\$280
1	Modesty/Back Panel — Short 48"W x 10"H	HNLMP4810	\$227	\$227
1	Right Credenza with Lateral File 72"W x 24"D x 29½"H	HNL2472RLC	\$1,616	\$1,616
1	Stack-on Storage, Frosted Doors with Silver Frame 72"W x 15"D x 48⅝"H	HNL4972FD	\$2,648	\$2,648
1	Vertical Paper Manager	HLVPM1	\$327	\$327
1	Wardrobe Left, Bookcase Right 36"W x 24"D x 78⅞"H	HNL243679WLBR	\$2,585	\$2,585

TOTAL: \$10,116

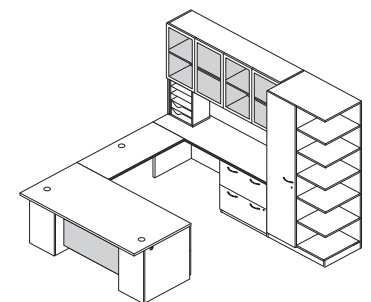

U-WORKSTATION

CONCINNITY™

Typicals



Icon Legend on page 19

QTY	DESCRIPTION	MODEL	LIST PRICE	PRICE EXTENSION
1	Rectangle Worksurface 72"W x 30"D	HNLRC3072	\$438	\$438
1	Rectangle Worksurface with Vertical Grain 42"W x 24"D	HNLRC2442V	\$262	\$262
1	Height Adjustable Base, 3-Leg	HHAB3S3L	\$1,896	\$1,896
1	Mixed Material Floating Modesty Panel 60"W x 14"H	HLSL6014MM	\$1,134	\$1,134
1	Rectangle Worksurface 72"W x 24"D	HNLRC2472	\$374	\$374
1	End Panel, Right 1½"W x 23½"D x 28½"H	HNLEP2428R	\$208	\$208
1	Box/Box/File Pedestal 15¾"W x 23½"D x 28½"H	HNL231628PBBF	\$728	\$728
1	Low Back Panel — For 15¾"W Pedestal 15¾"W x 18"H	HNLLB1618	\$131	\$131
1	Modesty/Back Panel — Short 72"W x 10"H	HNLMP7210	\$292	\$292
1	Wall Mount Storage, Frosted Doors with Silver Frame 72"W x 15"D x 15"H	HNL1572FD	\$1,829	\$1,829
1	Storage/File Cabinet, Hinged Left 18"W x 24"D x 64¾"H	HNL241865SFL	\$1,775	\$1,775
TOTAL:			\$9,067	

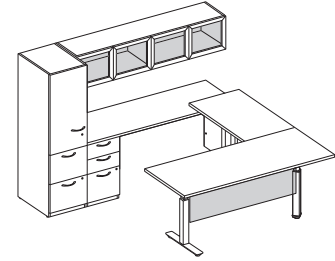

U-WORKSTATION WITH HEIGHT-ADJUSTABLE L-WORKSURFACE

QTY	DESCRIPTION	MODEL	LIST PRICE	PRICE EXTENSION
1	Rectangle Worksurface 72"W x 24"D	HNLRC2472	\$374	\$374
2	O-Leg Support for 24"D Worksurface 24"D x 28½"H	HLSL2428O	\$324	\$648
1	External Support Channel for 72"W Worksurface	HLSLZ5SC78	\$110	\$110
1	Low Credenza, Drawers Left, Bookcase Right 60"W x 20"D x 21½"H	HNL206021LD2	\$1,290	\$1,290
1	Rectangle Worksurface 54"W x 24"D	HNLRC2454	\$305	\$305
1	Standing-Height O-Leg Support for 24"D Worksurface 24"D x 41"H	HLSL2441O	\$433	\$433
1	Narrow Box/Box/File/File Pedestal 9½"W x 23½"D x 41"H	HNL231041PBBFF	\$1,349	\$1,349
1	Full Back Panel — For 41"H Pedestal 9½"W x 40¾"H	HNLBP1041	\$142	\$142
1	Storage Tower, Hinged Left 18"W x 24"D x 50"H	HNL241850TLL	\$1,270	\$1,270
TOTAL:			\$5,921	

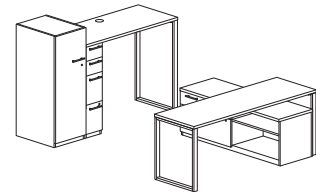

U-WORKSTATION WITH SITTING AND STANDING-HEIGHT WORKSURFACES — OPEN PLAN



Icon Legend on page 19

CONCINNITY™ Typicals

QTY	DESCRIPTION	MODEL	LIST PRICE	PRICE EXTENSION
1	Rectangle Worksurface 72"W x 30"D	HNLRC3072	\$438	\$438
1	O-Leg Support for 30"D Worksurface 30"D x 28½"H	HLSL30280	\$359	\$359
1	O-Leg Support over Low Credenza 30"D x 7"H	HLSL3070	\$277	\$277
1	External Support Channel for 72"W Worksurface	HLSLZ5SC78	\$110	\$110
1	Low Credenza, Drawers Right, Bookcase Left 60"W x 20"D x 21½"H	HNL206021RD2	\$1,290	\$1,290
1	Low Credenza, Drawers Left, Bookcase Right 60"W x 20"D x 21½"H	HNL206021LD2	\$1,290	\$1,290
2	Wall Mount Storage, Laminate Doors 30"W x 15"D x 28½"H	HNL2930LD	\$836	\$1,672
1	Wall Mount Storage, Frosted Doors with Silver Frame 30"W x 15"D x 28½"H	HNL2930FD	\$1,322	\$1,322
1	Wall Mount Markerboard 30"W x 48⅝"H	HNL4930WB	\$231	\$231
TOTAL:			\$6,989	

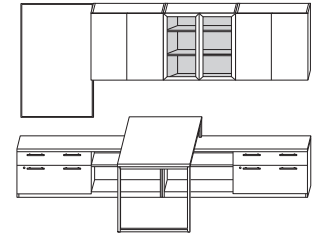

**WORKSTATION WITH
WORKWALL – OPEN PLAN**

QTY	DESCRIPTION	MODEL	LIST PRICE	PRICE EXTENSION
3	Rectangle Worksurface with Vertical Grain 48"W x 24"D	HNLRC2448V	\$280	\$840
3	O-Leg Support for 48"W x 24"D Worksurface 24"D x 28½"H	HLSL24280	\$324	\$972
3	Mixed Material Floating Modesty Panel 42"W x 14"H	HLSL4214MM	\$826	\$2,478
3	Rectangle Worksurface 72"W x 24"D	HNLRC2472	\$374	\$1,122
3	L-Shaped End Panel, Left 15¾"W x 24"D x 28½"H	HNLLEP2428L	\$339	\$1,017
3	Shelf/Box/Box/Lateral File Pedestal 30"W x 23⅜"D x 28½"H	HNL233028PSL	\$1,246	\$3,738
3	Modesty/Pedestal Back Panel 30"W x 27⅞"H	HNLMP3028	\$179	\$537
3	Wall Mount Storage, Frosted Doors with Silver Frame 72"W x 15"D x 15"H	HNL1572FD	\$1,829	\$5,487
TOTAL:			\$16,191	

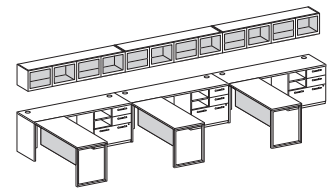

L-WORKSTATIONS – OPEN PLAN

CONCINNITY™

Typicals



Icon Legend on page 19

QTY	DESCRIPTION	MODEL	LIST PRICE	PRICE EXTENSION
1	Rectangle Worksurface with Vertical Grain 48"W x 24"D	HNLRC2448V	\$280	\$280
1	O-Leg Support for 48"W x 24"D Worksurface 24"D x 28½"H	HLSL2428O	\$324	\$324
1	Rectangle Worksurface 96"W x 24"D	HNLRC2496	\$544	\$544
1	Storage Cabinet Pedestal 36"W x 23⅞"D x 28½"H	HNL233628PSC	\$826	\$826
1	End Panel, Left 1⅞"W x 23⅞"D x 28½"H	HNLEP2428L	\$208	\$208
1	Modesty/Back Panel — Full-Length 96"W x 27⅞"H	HNLMP9628	\$439	\$439
1	Bookcase Hutch, Frosted Doors with Silver Frame 36"W x 15"D x 48⅝"H	HNL4936BHFD	\$1,729	\$1,729
1	Wall Mount Storage, Frosted Doors with Silver Frame 60"W x 15"D x 28½"H	HNL2960FD	\$2,284	\$2,284
1	Vertical Paper Manager	HLVPM1	\$327	\$327
1	Storage Tower, Wardrobe Right, Cabinet Left 24"W x 24"D x 78⅞"H	HNL242465TLR	\$2,280	\$2,280
TOTAL:			\$9,241	

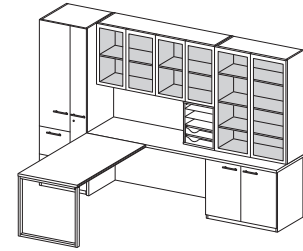

WORKSTATION WITH WORKWALL — OPEN PLAN

QTY	DESCRIPTION	MODEL	LIST PRICE	PRICE EXTENSION
4	Rectangle Worksurface 60"W x 24"D	HNLRC2460	\$333	\$1,332
4	Shelf/Box/Box/File Pedestal 15¾"W x 23⅞"D x 41"H	HNL231641PSBBF	\$1,534	\$6,136
4	Full Back Panel — For 15¾"W Pedestal 15¾"W x 40⅝"H	HNLPB1641	\$156	\$624
4	Narrow Box/Box/File/File Pedestal 9½"W x 23⅞"D x 41"H	HNL231041PBFF	\$1,349	\$5,396
4	Full Back Panel — For 9½"W Pedestal 9½"W x 40⅝"H	HNLPB1041	\$142	\$568
2	Above/Below Privacy Screen, Frosted 30"W x 28"H	HLSL2830	\$816	\$1,632
2	5-Shelf Bookcase with Coat Hooks, Right 24"W x 24"D x 64¾"H	HNL2424BK5CR	\$977	\$1,954
2	5-Shelf Bookcase with Coat Hooks, Left 24"W x 24"D x 64¾"H	HNL2424BK5CL	\$977	\$1,954
TOTAL:			\$19,596	

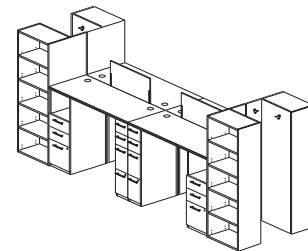

STANDING-HEIGHT — TEAMING WORKSTATION — OPEN PLAN

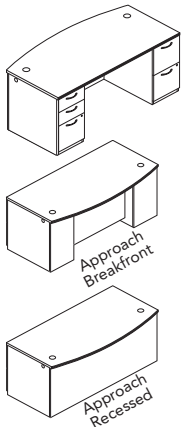

DESCRIPTION	APPROACH SIDE OVERHANG	MODEL	SHIP WEIGHT	CUBE	L1 LIST	L2 UPCHARGES		
						WORKSURFACES	CHASSIS	FRONTS
Double Pedestal Desk — Bow Top 72"W x 36"D x 29½"H, Recessed Modesty Panel	6"	HNL3672DPBR	298	51.8	\$2356	\$25	\$40	\$10
72"W x 36"D x 29½"H, Breakfront Modesty Panel	6-12"	HNL3672DPBB	282	51.8	\$2449	\$25	\$40	\$10
72"W x 36"D x 29½"H, Breakfront Frosted Modesty Panel	6-12"	HNL3672DPBBF	266	51.8	\$2941	\$25	\$40	\$10

NOTES: For laminate center drawer, see page 106. For pull-out collaborative shelf, for desks with breakfront modesty panel, see page 106.

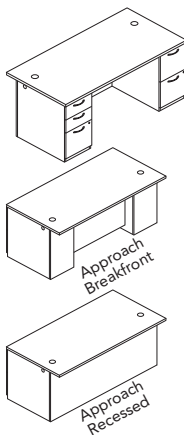

Double Pedestal Desk — Rectangle Top 72"W x 36"D x 29½"H, Rectangle Top, Recessed Modesty Panel	6"	HNL3672DPRR	292	51.8	\$1994	\$25	\$40	\$10
66"W x 30"D x 29½"H, Rectangle Top, Flush Modesty Panel		HNL3066DPRF	267	40.2	\$1876	\$20	\$35	\$10
60"W x 30"D x 29½"H, Rectangle Top, Flush Modesty Panel		HNL3060DPRF	257	40.2	\$1753	\$20	\$45	\$20
72"W x 36"D x 29½"H, Rectangle Top, Breakfront Modesty Panel	6-12"	HNL3672DPRB	287	51.8	\$2219	\$25	\$40	\$10
72"W x 36"D x 29½"H, Rectangle Top, Breakfront Frosted Modesty Panel	6-12"	HNL3672DPRBF	270	51.8	\$2712	\$25	\$40	\$10

NOTES: For laminate center drawer, see page 106. For pull-out collaborative shelf, for desks with breakfront modesty panel, see page 106.

NOTES:

- Feature full-to-the-floor pedestals to maximize storage space.
- Double pedestal desks have 3/2 drawer configuration (box/box/file on left pedestal, file/file on right pedestal).
- Single pedestal desks have a box/box/file pedestal.
- One molded black pencil tray is included in each box/box/file pedestal.
- 72"W models are available with Rectangle- or bow-shaped tops.
- Bow top desk models measure 36"D at the crest and 30"D along the end panels.
- Formal breakfront or recessed modesty panel.
- Breakfront desk features a floating modesty panel which can be specified in laminate or frosted material. Floating design provides space for optional pull-out collaborative shelf for visitors. See page 106.
- Recessed modesty panel design has a full-width conference overhang, providing worksurface and kneespace for guests.
- 66"W and 60"W desks have a flush modesty panel (i.e., no conference overhang).
- Two cord management grommets, for routing and hiding wires and cables, are located in desktops.
- Grommets can be replaced with optional Power (model HGRMTAC) or USB Hub (HGRMTUSB2).
- Pedestal sides and end panels are standard with pass-through grommets to enable the routing of cords below the worksurface, and connections between workstations.
- Specification logic includes the grommet finish for tops; choose from Black (P) or Platinum (T1). Side grommets on pedestal are black only.
- See "Modular Components" for cord management options. Worksurfaces/tops, end and modesty panels, and pedestals can be specified with or without grommets.
- Finish of pedestal lock(s) is determined by, and aligned with, the handle finish specified.
- Adjustable hex leveling glides.
- Ship fully assembled.

HOW TO SPECIFY

Select Model Number	Select Edge Profile and Edge Color	Select Handle	Select Worksurface Grommet Finish	Select Worksurface Color	Select Chassis Color	Select Drawer Front Color
See page 29	See page 29	A Cylinder – Satin B Cylinder – Black C Canopy – Satin D Canopy – Black E Loop – Satin F Loop – Black	P Black T1 Platinum	See page 29	See page 29	See page 29
HNL3672DPBR	BH	E	T1	H	H	H

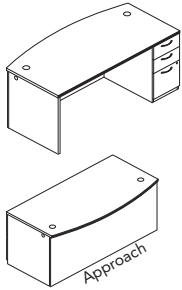

DESCRIPTION	APPROACH SIDE OVERHANG	MODEL	SHIP WEIGHT	CUBE	L1 LIST	L2 UPCHARGES		
						WORKSURFACES	CHASSIS	FRONTS
Single Pedestal Desk — Bow Top 72"W x 36"D x 29½"H, Right, Recessed Modesty Panel (shown)	6"	HNL3672RPBR	238	51.8	\$1893	\$25	\$40	\$10
72"W x 36"D x 29½"H, Left, Recessed Modesty Panel	6"	HNL3672LPBR	238	51.8	\$1893	\$25	\$40	\$10
72"W x 36"D x 29½"H, Right, Breakfront Modesty Panel	6-12"	HNL3672RPBB	237	51.8	\$2134	\$25	\$40	\$10
72"W x 36"D x 29½"H, Left, Breakfront Modesty Panel	6-12"	HNL3672LPBB	237	51.8	\$2134	\$25	\$40	\$10
72"W x 36"D x 29½"H, Right, Breakfront Frosted Modesty Panel	6-12"	HNL3672RPBBF	221	51.8	\$2617	\$25	\$40	\$10
72"W x 36"D x 29½"H, Left, Breakfront Frosted Modesty Panel	6-12"	HNL3672LPBBF	221	51.8	\$2617	\$25	\$40	\$10

NOTES: For laminate center drawer, see page 106. For pull-out collaborative shelf, for desks with breakfront modesty panel, see page 106.

NOTES:

- Feature full-to-the-floor pedestals to maximize storage space.
- Double pedestal desks have 3/2 drawer configuration (box/box/file on left pedestal, file/file on right pedestal).
- Single pedestal desks have a box/box/file pedestal.
- One molded black pencil tray is included in each box/box/file pedestal.
- 72"W models are available with Rectangle- or bow-shaped tops.
- Bow top desk models measure 36"D at the crest and 30"D along the end panels.
- Formal breakfront or recessed modesty panel.
- Breakfront desk features a floating modesty panel which can be specified in laminate or frosted material. Floating design provides space for optional pull-out collaborative shelf for visitors. See page 106.
- Recessed modesty panel design has a full-width conference overhang, providing workspace and kneespace for guests.
- 66"W and 60"W desks have a flush modesty panel (i.e., no conference overhang).
- Two cord management grommets, for routing and hiding wires and cables, are located in desktops.
- Grommets can be replaced with optional Power (model HGRMTAC) or USB Hub (HGRMTUSB2).
- Pedestal sides and end panels are standard with pass-through grommets to enable the routing of cords below the workspace, and connections between workstations.
- Specification logic includes the grommet finish for tops; choose from Black (P) or Platinum (TI). Side grommets on pedestal are black only.
- See "Modular Components" for cord management options. Worksurfaces/tops, end and modesty panels, and pedestals can be specified with or without grommets.
- Finish of pedestal lock(s) is determined by, and aligned with, the handle finish specified.
- Adjustable hex leveling glides.
- Ship fully assembled.

HOW TO SPECIFY

Select Model Number	Select Edge Profile and Edge Color	Select Handle	Select Worksurface Grommet Finish	Select Worksurface Color	Select Chassis Color	Select Drawer Front Color
See page 29	See page 29	See page 29	See page 29	See page 29	See page 29	See page 29
H N L 3 6 7 2 R P B R	B H	E	T I	H	H	H

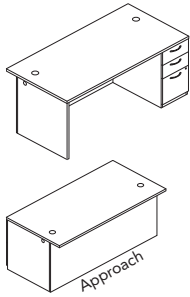

DESCRIPTION	APPROACH SIDE OVERHANG	MODEL	SHIP WEIGHT	CUBE	L1 LIST	L2 UPCHARGES		
						WORKSURFACES	CHASSIS	FRONTS
Single Pedestal Desk — Rectangle Top 72"W x 36"D x 29½"H, Right, Recessed Modesty Panel (shown)	6"	HNL3672RPRR	242	51.8	\$1635	\$25	\$40	\$10
72"W x 36"D x 29½"H, Left, Recessed Modesty Panel	6"	HNL3672LPRR	242	51.8	\$1635	\$25	\$40	\$10
66"W x 30"D x 29½"H, Right, Flush Modesty Panel		HNL3066RPRF	217	40.2	\$1596	\$20	\$35	\$10
66"W x 30"D x 29½"H, Left, Flush Modesty Panel		HNL3066LPRF	217	40.2	\$1596	\$20	\$35	\$10
72"W x 36"D x 29½"H, Right, Breakfront Modesty Panel	6-12"	HNL3672RPRB	242	51.8	\$1949	\$25	\$40	\$10
72"W x 36"D x 29½"H, Left, Breakfront Modesty Panel	6-12"	HNL3672LPRB	242	51.8	\$1949	\$25	\$40	\$10
72"W x 36"D x 29½"H, Right, Breakfront Frosted Modesty Panel	6-12"	HNL3672RPRBF	225	51.8	\$2433	\$25	\$40	\$10
72"W x 36"D x 29½"H, Left, Breakfront Frosted Modesty Panel	6-12"	HNL3672LPRBF	225	51.8	\$2433	\$25	\$40	\$10

NOTES: For laminate center drawer, see page 106. For pull-out collaborative shelf, for desks with breakfront modesty panel, see page 106.

NOTES:

- Feature full-to-the-floor pedestals to maximize storage space.
- Double pedestal desks have 3/2 drawer configuration (box/box/file on left pedestal, file/file on right pedestal).
- Single pedestal desks have a box/box/file pedestal.
- One molded black pencil tray is included in each box/box/file pedestal.
- 72"W models are available with Rectangle- or bow-shaped tops.
- Bow top desk models measure 36"D at the crest and 30"D along the end panels.
- Formal breakfront or recessed modesty panel.
- Breakfront desk features a floating modesty panel which can be specified in laminate or frosted material. Floating design provides space for optional pull-out collaborative shelf for visitors. See page 106.
- Recessed modesty panel design has a full-width conference overhang, providing workspace and kneespace for guests.
- 66"W and 60"W desks have a flush modesty panel (i.e., no conference overhang).
- Two cord management grommets, for routing and hiding wires and cables, are located in desktops.
- Grommets can be replaced with optional Power (model HGRMTAC) or USB Hub (HGRMTUSB2).
- Pedestal sides and end panels are standard with pass-through grommets to enable the routing of cords below the worksurface, and connections between workstations.
- Specification logic includes the grommet finish for tops; choose from Black (P) or Platinum (T1). Side grommets on pedestal are black only.
- See "Modular Components" for cord management options. Worksurfaces/tops, end and modesty panels, and pedestals can be specified with or without grommets.
- Finish of pedestal lock(s) is determined by, and aligned with, the handle finish specified.
- Adjustable hex leveling glides.
- Ship fully assembled.

HOW TO SPECIFY

Select Model Number	Select Edge Profile and Edge Color	Select Handle	Select Worksurface Grommet Finish	Select Worksurface Color	Select Chassis Color	Select Drawer Front Color
	See page 29	A Cylinder – Satin B Cylinder – Black C Canopy – Satin D Canopy – Black E Loop – Satin F Loop – Black	P Black T1 Platinum	See page 29	See page 29	See page 29
H N L 3 6 7 2 R P R R	B H	E	T 1	H	H	H

CONCINNITY™

Peninsulas

GSA SIN 33721



Icon Legend on page 19

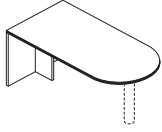

Support column sold separately



DESCRIPTION	MODEL	SHIP WEIGHT	CUBE	L1 LIST	L2 UPCHARGES	
					WORKSURFACE	CHASSIS
Bullet Peninsula with End Panel						
72"W x 36"D x 29½"H	HNL3672BUEP	131	6.6	\$916	\$25	\$40
72"W x 30"D x 29½"H	HNL3072BUEP	112	5.6	\$799	\$20	\$25
66"W x 30"D x 29½"H	HNL3066BUEP	105	5.1	\$716	\$20	\$35

NOTES: For use in "U" or "L" shaped furniture layouts; not to be used freestanding. Comprised of top and end/brace panels (Note: Must specify support column; sold separately). Cord routing notch in the brace panel. Adjustable hex leveling glides. For cord grommet options, see "Modular Components". Options include center drawers and modesty panels. Modesty panel is available in laminate or frosted material. Ships

Not designed to be used freestanding.

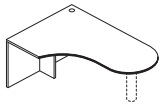
Right-hand model
HNL4872JREP shown

Support column sold separately



DESCRIPTION	MODEL	SHIP WEIGHT	CUBE	L1 LIST	L2 UPCHARGES	
					WORKSURFACE	CHASSIS
Jetty Peninsula with End Panel						
72"W x 30/48"D x 29½"H, Right	HNL4872JREP	147	8.9	\$1101	\$30	\$25
72"W x 30/48"D x 29½"H, Left	HNL4872JLEP	147	8.9	\$1101	\$30	\$25
72"W x 30/42"D x 29½"H, Right	HNL4272JREP	134	17.0	\$1024	\$30	\$25
72"W x 30/42"D x 29½"H, Left	HNL4272JLEP	134	17.0	\$1024	\$30	\$25

NOTES: Worksurface designed and sized to efficiently serve as both a computing and conferencing space. Two sizes, 42"D and 48"D. The 48"D unit is specifically intended to be used with the 48"D extended corner modular top/back components to form a two-piece U-shaped workstation with a 42" cockpit area. For use in "U" or "L" shaped furniture layouts; not to be used freestanding. Comprised of top and end/brace panels (Note: Must specify support column; sold separately). One cord management grommet in the top; cord routing notch in the brace panel. Adjustable hex leveling glides. Field installable modesty panel is optional. Ships

Not designed to be used freestanding.

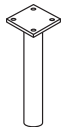

DESCRIPTION	MODEL	SHIP WEIGHT	CUBE	LIST PRICE
Support Column for Bullet and Jetty Peninsulas 3" Diameter. Specify: HPC190X.P. Black only.	HPC190X	12	1.0	\$161
Support Column for Bullet and Jetty Peninsulas 3" Diameter. Specify: HPC191X.X. Available in Silver only.	HPC191X	12	1.0	\$161

Support Column must be specified/ordered with Bullet and Jetty peninsulas.



NOTES:

- See pages 92-96 for shared components.

HOW TO SPECIFY

Select Model Number H N L 3 6 7 2 B U E P	Select Edge Profile and Edge Color See page 29 B H	Select Worksurface Color See page 29 H	Select Chassis Color See page 29 H	
Select Model Number H N L 4 8 7 2 J R E P	Select Edge Profile and Edge Color See page 29 B H	Select Worksurface Grommet Finish P Black T1 Platinum	Select Worksurface Color See page 29 H	Select Chassis Color See page 29 H



	DESCRIPTION	MODEL	SHIP WEIGHT	CUBE	LIST PRICE BY PAINT GRADE		
					P1	P2	P3
	Post Leg Base 28½" H x 2" square NOTES: Can only be used as the outbound support in a peninsula or island extension worksurface application. Glides have 2" of adjustability. Ship 1/pack. SPECIFYING EXAMPLE: HLSL28P.T1	HLSL28P	15	1.0	\$298	\$302	\$318
	Field Installable Modesty Panel for Bullet and Jetty Peninsulas, Laminate (Vertical Grain) 50¼"W x ¾" Thick x 18"H NOTES: Center drawer model H1522 can be used in conjunction with laminate modesty panel model HPC180W. Cord pass-through notch in top corner. SPECIFYING EXAMPLE: HPC180W.H	HPC180W	28	3.6	\$215		
	Field Installable Modesty Panel for Bullet and Jetty Peninsulas, Frosted with Silver Frame 50¼"W x ¾" Thick x 18"H ⚠ Cord pass-through notch is not available on the Frosted/Silver model HPC180G. Notch is on laminate model HPC180W only. ⚠ Center drawers not designed to be used with the frosted/silver modesty panel model HPC180G.	HPC180G	33	1.5	\$694		

NOTES:

- See pages 92-96 for shared components.

HOW TO SPECIFY

Select Model Number

H	L	S	L	2	8	P
---	---	---	---	---	---	---

CONCINNITY™

Corner Unit

GSA SIN 33721



Icon Legend on page 19

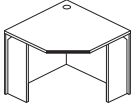

DESCRIPTION	MODEL	SHIP WEIGHT	CUBE	L1 LIST	L2 UPCHARGES	
					WORKSURFACE	CHASSIS
Corner Unit 24"W x 36"D x 24" x 29½"H	HNL3636CU	109	26.4	\$964	\$15	\$20
NOTES: Designed for use with 24"D returns or bridges. Can be used freestanding. Can be used with two 36"W modular returns to achieve an efficient 6' x 6' layout. One cord management grommet in the top; cord routing notches in the leg panels. The worksurface grommet can be replaced with optional power (model HGRMTAC) or USB (model HGRMTUSB2) hub. Adjustable hex leveling glides. When connected to a 42"W return or modular return, the 78"W stack-on storage unit spans the total depth dimension (78"D). When connected to a 36"W modular return, the 72"W stack-on storage unit spans the total depth dimension (72"D). Edgebanding on the corner unit is profiled on the user's side and flat on the back (approach side) and ends. Ships fully assembled.						

NOTES:

- For Extended Corner Worksurface sizes, see "Modular Components" on page 78.

HOW TO SPECIFY

Select
Model Number

H N L 3 6 3 6 C U .

Select
Edge Profile and Edge
Color

See page 29

B H .

Select
Worksurface Grommet
Finish

P Black
T1 Platinum

P .

Select
Worksurface Color

See page 29

H .

Select
Chassis Color

See page 29

H

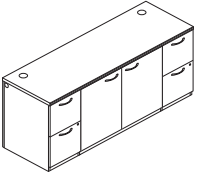
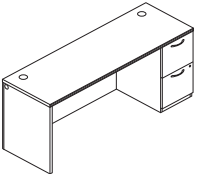

DESCRIPTION	MODEL	SHIP WEIGHT	CUBE	L1 LIST	L2 UPCHARGES		
					WORKSURFACES	CHASSIS	FRONTS
 <p>Credenza with Storage 72"W x 24"D x 29½"H</p> <p>NOTES: For use behind a desk or as a stand-alone storage piece. Four file drawers, 2-left, 2-right and one storage cabinet with hinged doors. One adjustable shelf, which adjusts in 2½" increments, behind doors. Drawers lock. Finish of locks is determined by, and aligned with, the handle finish specified. Storage cabinet doors are non-locking.</p>	HNL2472DPS	323	35.6	\$2452	\$20	\$45	\$40
	<p>Credenza with Kneespace</p> <p>72"W x 24"D x 29½"H HNL2472DPK 247 35.6 \$1855 \$20 \$40 \$20</p> <p>66"W x 24"D x 29½"H HNL2466DPK 239 32.7 \$1770 \$20 \$40 \$20</p> <p>60"W x 24"D x 29½"H HNL2460DPK 230 29.9 \$1741 \$20 \$35 \$20</p> <p>NOTES: For use behind a desk or as a stand-alone storage piece. Four locking file drawers, 2-left, 2-right. Finish of locks determined by, and aligned with, the handle finish specified.</p>						
 <p>Credenza, Single Pedestal</p> <p>72"W x 24"D x 29½"H, Right HNL2472RP 199 35.6 \$1479 \$20 \$35 \$10</p> <p>72"W x 24"D x 29½"H, Left HNL2472LP 199 35.6 \$1479 \$20 \$35 \$10</p> <p>NOTES: Primary use is as part of a connected U-shaped workstation with a bridge and single pedestal desk. Two locking file drawers. Finish of lock determined by, and aligned with, the handle finish specified. Can be used with modular or mobile pedestals.</p>	<p>Credenza with Lateral File</p> <p>72"W x 24"D x 29½"H, Right HNL2472RLC 245 35.6 \$1616 \$20 \$35 \$20</p> <p>72"W x 24"D x 29½"H, Left HNL2472LLC 245 35.6 \$1616 \$20 \$35 \$20</p> <p>NOTES: Storage file measures 30"W (36"W can be specified using modular components). Mechanical interlock inhibits the extension of more than one drawer at a time. Finish of lock is determined by, and aligned with, the handle finish specified. Can be used with modular or mobile pedestals.</p>						

NOTES:

- Optional 72"W, 66"W and 60"W stack-on sizes maximize storage space.
- Two cord management grommets, for routing and hiding wires and cables, are located in top.
- Modesty panel and pedestal grommets are black only.
- A cord pass-through grommet is located in the sides of the pedestal and top center of the back (modesty panel) to facilitate reaching wall electrical outlets.
- Specification logic includes the grommet finish for tops; choose from Black (P) or Platinum (TI).
- Worksurfaces/tops, end and modesty panels, and pedestals can be specified with or without grommets. See "Modular Components" on page 36 for cord management options.
- For paper organizers, see page 110.

HOW TO SPECIFY

Select Model Number	Select Edge Profile and Edge Color	Select Handle	Select Worksurface Grommet Finish	Select Worksurface Color	Select Chassis Color	Select Drawer Front Color
See page 29	See page 29	See page 29	See page 29	See page 29	See page 29	See page 29
H N L 2 4 7 2 D P S	B H	E	T I	H	H	H

CONCINNITY™ Low Credenzas

GSA SIN 33721



Icon Legend on page 19

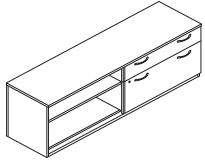

DESCRIPTION	MODEL	SHIP WEIGHT	CUBE	L1 LIST	L2 UPCHARGES		
					WORKSURFACES	CHASSIS	FRONTS
Low Credenza (Bench-Height) 72"W x 20"D x 21½"H, Drawers Right, Bookcase Left (shown)	HNL207221RD2	219	21.6	\$1437	\$15	\$25	\$20
72"W x 20"D x 21½"H, Drawers Left, Bookcase Right	HNL207221LD2	219	21.6	\$1437	\$15	\$25	\$20
60"W x 20"D x 21½"H, Drawers Right, Bookcase Left	HNL206021RD2	187	18.1	\$1290	\$20	\$15	\$20
60"W x 20"D x 21½"H, Drawers Left, Bookcase Right	HNL206021LD2	187	18.1	\$1290	\$20	\$15	\$20

NOTES: Combination storage design comprised of two locking drawers (1-box/supply and 1-file) plus a bookcase. File drawers include integrated hangrails for letter- or legal-sized folders. Bookcase has one adjustable shelf; adjusts in 2½" increments.

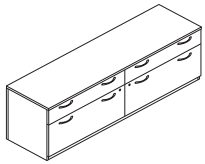

Low Credenza, 2 Box/2 File 72"W x 20"D x 21½"H	HNL207221D4	308	21.6	\$1747	\$15	\$25	\$40
60"W x 20"D x 21½"H	HNL206021D4	260	18.1	\$1548	\$15	\$20	\$40

NOTES: Four locking drawers (2-box/supply and 2-file). File drawers include integrated hangrails for letter- or legal-sized folders.

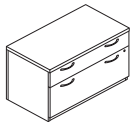

Low Credenza, Box/File 36"W x 20"D x 21½"H	HNL203621D2	143	11.8	\$1012	\$10	\$15	\$20
30"W x 20"D x 21½"H	HNL203021D2	121	10.0	\$951	\$10	\$15	\$20

NOTES: Unit contains two drawers, one box and one lateral file.

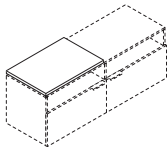

DESCRIPTION	MODEL	SHIP WEIGHT	CUBE	LIST PRICE BY FABRIC GRADE					
				1	2	3	4	5	6
Credenza Cushion 36"W x 20"D x 1"H for 72" and 36"W Low Credenzas	HLSL2036CH2	11	2.2	\$410	\$448	\$486	\$525	\$574	\$624
30"W x 20"D x 1"H for 60" and 30"W Low Credenzas	HLSL2030CH2	9	1.9	\$380	\$416	\$452	\$488	\$534	\$581

NOTES: See pages 22-24 for available fabrics.

Seat cushions are optional; HLSL2036CH2 for 72" and 36"W, HLSL2030CH2 for 60" and 30"W.

! For model HLSL2030CH2 must order two cushions to cover entire 60" Credenza surface.

SPECIFYING EXAMPLE: HLSL2036CH2.APN23

NOTES:

- Versatile, space-saving solutions double as a compact storage unit and convenient bench seat.
- When combined with 29½"H worksurfaces, the 21½"H credenzas can be positioned to create multi-level, overlapping surfaces that optimize floor space, organization and display needs.
- The distinct, clean horizontal planes provide a light scale, layered look.
- Low-heights help facilitate team collaboration.
- Finish of lock(s) is determined by, and aligned with, the handle finish specified.
- Overlapping surfaces can be supported by a 28½"H or 7"H O-leg or 7"H laminate end panel.

HOW TO SPECIFY

<p>Select Model Number</p> <p>H N L 2 0 7 2 2 1 R D 2 .</p>	<p>Select Edge Profile and Edge Color</p> <p>See page 29</p> <p>B H .</p>	<p>Select Handle</p> <p>A Cylinder - Satin B Cylinder - Black C Canopy - Satin D Canopy - Black E Loop - Satin F Loop - Black</p> <p>E .</p>	<p>Select Top Color</p> <p>See page 29</p> <p>H .</p>	<p>Select Chassis Color</p> <p>See page 29</p> <p>H .</p>	<p>Select Drawer Front Color</p> <p>See page 29</p> <p>H .</p>
--	--	---	--	--	---

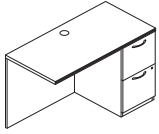

DESCRIPTION	MODEL	SHIP		L1 LIST	L2 UPCHARGES		
		WEIGHT	CUBE		WORKSURFACES	CHASSIS	FRONTS
Return							
48"W x 24"D x 29½"H, Right (shown)	HNL2448RP	141	24.8	\$1061	\$15	\$15	\$10
48"W x 24"D x 29½"H, Left	HNL2448LP	141	24.8	\$1061	\$15	\$15	\$10
42"W x 24"D x 29½"H, Right	HNL2442RP	132	22.0	\$1016	\$15	\$15	\$10
42"W x 24"D x 29½"H, Left	HNL2442LP	132	22.0	\$1016	\$15	\$15	\$10

NOTES: For L-shaped workstations. Connects to single pedestal desk, peninsula (bullet or jetty), or component worksurface with end panel. Drawers lock. Finish of lock is determined by, and aligned with, the handle finish specified. Formal, full-height modesty panel. One cord grommet in top for routing and hiding wires and cables. One cord pass-through grommet is located in the sides of the pedestal and top center of the back (modesty panel) to facilitate reaching wall electrical outlets. Specification logic includes the grommet finish for tops; choose from Black (P) or Platinum (TI). Modesty panel and pedestal grommets are black only. Edgebanding on 42"W and 48"W returns is profiled on the user's side and flat on the back (approach side) and ends. Woodgrain direction on worksurface runs vertical (i.e., front-to-back). Smaller and larger return sizes can be specified using modular worksurface and modesty panel components. Optional stack-on solutions maximize storage space. Ship fully assembled.

See chart on page 36 for cord management options. Worksurfaces/tops, end and modesty panels, and pedestals can be specified with or without grommets. For easy access to wall electrical outlets, options include a short (10") modesty panel or no back panel.

For paper organizers, see page 110.

HOW TO SPECIFY

<p>Select Model Number</p>	<p>Select Edge Profile and Edge Color</p> <p>See page 29</p>	<p>Select Handle</p> <p>A Cylinder – Satin B Cylinder – Black C Canopy – Satin D Canopy – Black E Loop – Satin F Loop – Black</p>	<p>Select Worksurface Grommet Finish</p> <p>P Black TI Platinum</p>	<p>Select Worksurface Color</p> <p>See page 29</p>	<p>Select Chassis Color</p> <p>See page 29</p>	<p>Select Drawer Front Color</p> <p>See page 29</p>
<p>H N L 2 4 4 8 R P .</p>	<p>B H .</p>	<p>E .</p>	<p>T I .</p>	<p>H .</p>	<p>H .</p>	<p>H .</p>

CONCINNITY™ Bridges

GSA SIN 33721



Icon Legend on page 19

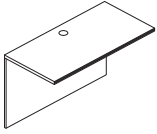

DESCRIPTION	MODEL	SHIP WEIGHT	CUBE	L1 LIST	L2 UPCHARGES		
					WORKSURFACES	CHASSIS	FRONTS
Bridge 48"W x 24"D x 29½"H	HNL2448BF	71	3.0	\$457	\$15	\$15	N/A
42"W x 24"D x 29½"H	HNL2442BF	62	2.5	\$437	\$15	\$15	N/A

NOTES: For U-shaped workstation layouts. Connects single pedestal desk, peninsula (bullet or jetty), or component worksurface to corner unit or to single pedestal credenza, credenza with lateral file, or rectangle worksurface. Formal, full-height modesty panel. One cord grommet in top for routing and hiding wires and cables. One cord pass-through grommet in top center of back (modesty panel). Specification logic includes the grommet finish for tops; choose from Black (P) or Platinum (T1). Clear inside depth 22⁷/₈"D. Edgebanding on 42"W and 48"W bridges is profiled on the user's side and flat on the back (approach side) and ends. Woodgrain direction on worksurface runs vertical (i.e., front-to-back). Additional sizes, including 30"W and 36"W for use with corner or extended corner units, as well as jetty peninsulas, can be specified using modular worksurface and modesty panel components. Ship — quick, simple assembly. See chart on page 36 for cord management options. Worksurfaces/tops and modesty panels can be specified with or without grommets. For easy access to wall electrical outlets, options include a short (10") modesty panel or no back panel.

HOW TO SPECIFY

Select
Model Number

H N L 2 4 4 8 B F .

Select
Edge Profile and Edge
Color

See page 29

B H .

Select
Worksurface Grommet
Finish

P Black
T1 Platinum

P .

Select
Worksurface Color

See page 29

H .

Select
Chassis Color

See page 29

H .

CONCINNITY™ STACK-ON STORAGE APPLICATIONS

STACK-ON STORAGE APPLICATIONS

78"W

- Spans full-width of 78"W modular credenza or return.
- Spans total depth dimension of "L" workstation configurations comprised of:
 - 48"W return or modular return attached to a 36"D single pedestal desk with a bow front (78"D).
 - NOTE: The 36"D single pedestal desk with bow front is 30"D along end panel.
 - 48"W return or modular return attached to a 30"D single pedestal desk, modular desk, or bullet peninsula (78"D).
 - 42"W return or modular return attached to a 36"D single pedestal desk with rectangle top, modular desk, or bullet peninsula (78"D).
 - 42"W return or modular return attached to a 36" corner unit or 36"D extended corner unit (78"D).
 - 36"W modular return attached to a 42"D jetty peninsula (78"D).
 - 30"W modular return attached to a 48"D jetty peninsula (78"D).
 - 30"W modular return attached to a 48"D extended corner unit (78"D).

72"W

- Spans full-width of 72"W desks with rectangle top, credenzas, extended corner units, or modular desk, credenza, or return.
- Spans total depth dimension of "L" workstation configurations comprised of:
 - 48"W return or modular return attached to a 24"D single pedestal credenza or modular credenza (72"D).
 - 42"W return or modular return attached to a 36"D single pedestal desk with a bow front (72"D).
 - NOTE: The 36"D single pedestal desk with bow front is 30"D along end panel.
 - 42"W return or modular return attached to a 30"D single pedestal desk, modular desk, or bullet peninsula (72"D).
 - 36"W modular return attached to a 36"D single pedestal desk with rectangle top, modular desk, or bullet peninsula (72"D).
 - 36"W modular return attached to a 36" corner unit or 36"D extended corner unit (72"D).
 - 30"W modular return attached to a 42"D jetty peninsula (72"D).

66"W

- Spans full-width of 66"W desk, credenza, or modular desk, credenza, or return.
- Spans total depth dimension of "L" workstation configurations comprised of:
 - 42"W return or modular return attached to a 24"D single pedestal credenza or modular credenza (66"D).

- 36"W modular return attached to a 30"D single pedestal desk, bullet peninsula, or modular desk (66"D).
- 36"W modular return attached to a 36"D single pedestal desk with a bow front (66"D).
 - NOTE: The 36"D single pedestal desk with bow front is 30"D along end panel.
- 30"W modular return attached to a 36"D single pedestal desk with rectangle top or modular desk (66"D).
- 30"W modular return attached to a 36" corner unit (66"D).

60"W

- Spans full-width of 60"W desk, credenza, or modular desk, credenza, or return.
- Spans total depth dimension of "L" workstation configurations comprised of:
 - 36"W modular return attached to a 24"D single pedestal credenza or modular credenza (60"D).
 - 30"W modular return attached to a 30"D single pedestal desk or modular desk (60"D).

48"W

- Spans full-width of 48"W return, modular return, or modular desk or credenza.
- Spans full-depth of the 48"D jetty peninsula or extended corner unit.

42"W

- Spans full-width of 42"W return, modular return, or modular desk or credenza.
- Spans full-depth of 42"D jetty peninsula.

36"W

- Spans full-width of 36"W modular return, modular desk or credenza, two drawer lateral file, or 29½"H storage cabinet with doors.
- Spans full-depth of 36"D desks with rectangle top, bullet peninsula, extended corner unit, or 36" corner unit.

OPTIONS INCLUDE:

- Door/Storage Options:

Door(s)	Standard-Height	Executive-Height
Laminate	•	•
Laminate Locking	•	•
Frosted/Silver	•	•
Sliding	•	•

- Available in 35¼" or 78⅛"H; when positioned on 29½"H base unit, heights respectively align with 64¾" and 78⅛"H storage- and wardrobe-type cabinets.
- Paper organizers for stack-on and wall mounted storage cabinets (see application and compatibility information on page 111).

CONCINNITY™ STACK-ON STORAGE APPLICATIONS

- Fabric-Covered Tackboards:
 - Sized $\frac{3}{4}$ " narrower than the stack-on storage back enclosure, allowing $\frac{3}{8}$ " on each side to route task light cords.
 - Includes adhesive latch & hook tape for attachment to stack-on storage back panel and fasteners for wall mount applications.
 - For a list of standard fabrics, see pages 25-26. For a complete list of fabrics, please go to hon.com/fabricsandfinishes.
- Markerboards:
 - HLSL1530SOMB: 29½"W x 12½"H panel attaches to 60" and 66"W stack-on and wall mounted storage with sliding door models with double-sided tape.
 - HLSL1536SOMB: 35½"W x 12½"H panel attaches to 72" and 78"W stack-on and wall mounted storage with sliding door models with double-sided tape.
- Markerboards will not fit on stack-on storage laminate or laminate locking door models.
- Task Lights:
 - Attach to underside of stack-on and wall mount storage cabinets.
 - Fluorescent or LED options.
 - Tackboard and fluorescent and LED task light solutions, by model, for each stack-on storage size:

Stack-on Storage	Tackboard	Fluorescent Task Light	LED Task Light
78"W	H90057	HH870960, HH870960CH	HLED31A, HLED31AUO
72"W	H90056	HH870960, HH870960CH	HLED31A, HLED31AUO
66"W	H90055	HH870960, HH870960CH	HLED31A, HLED17AUO
60"W	H90054	HH870960, HH870960CH	HLED31A, HLED17AUO
48"W	H90053	HH870942, HH870942CH	HLED31AS
42"W	H90052	HH870942, HH870942CH	HLED31AS
36"W	H90051	HH870930, HH870930CH	HLED17AS



CONCINNITY™ Stack-on Storage

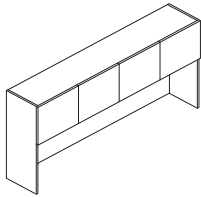

DESCRIPTION

Stack-on Storage, Laminate Doors
 78"W x 15"D x 35¼"H — 4 doors, 2 compartments
 72"W x 15"D x 35¼"H — 4 doors, 2 compartments
 66"W x 15"D x 35¼"H — 4 doors, 2 compartments
 60"W x 15"D x 35¼"H — 4 doors, 2 compartments
 48"W x 15"D x 35¼"H — 3 doors, 2 compartments
 42"W x 15"D x 35¼"H — 2 doors, 1 compartment
 36"W x 15"D x 35¼"H — 2 doors, 1 compartment

MODEL	SHIP WEIGHT	CUBE	L1 LIST	L2 UPCHARGES	
				CHASSIS	FRONTS
HNL3678LD	173	31.8	\$1349	\$45	\$20
HNL3672LD	162	29.0	\$1293	\$35	\$20
HNL3666LD	151	26.7	\$1276	\$35	\$20
HNL3660LD	139	24.3	\$1164	\$35	\$20
HNL3648LD	117	19.6	\$1050	\$30	\$20
HNL3642LD	100	18.1	\$1024	\$30	\$10
HNL3636LD	88	15.3	\$866	\$30	\$10

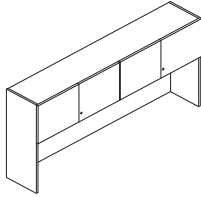

Stack-on Storage, Laminate Locking Doors

78"W x 15"D x 35¼"H — 4 doors, 2 compartments
 72"W x 15"D x 35¼"H — 4 doors, 2 compartments
 66"W x 15"D x 35¼"H — 4 doors, 2 compartments
 60"W x 15"D x 35¼"H — 4 doors, 2 compartments
 48"W x 15"D x 35¼"H — 3 doors, 2 compartments
 42"W x 15"D x 35¼"H — 2 doors, 1 compartment
 36"W x 15"D x 35¼"H — 2 doors, 1 compartment

HNL3678LL	173	31.8	\$1433	\$45	\$20
HNL3672LL	162	29.0	\$1377	\$35	\$20
HNL3666LL	151	26.7	\$1360	\$35	\$20
HNL3660LL	139	24.3	\$1248	\$35	\$20
HNL3648LL	117	19.6	\$1113	\$30	\$20
HNL3642LL	100	18.1	\$1066	\$30	\$10
HNL3636LL	88	15.3	\$908	\$30	\$10

! Lock available in Black (P) or Satin (SA) finish. Lock is core removable. Keyed alike cores must be ordered separately. For stack-on and wall mount storage with locking hinged doors, specify model HF27B (Black) or HF27S (Satin) and the key number, see page 112. Model HNL3648LL has one lock, which secures two of the three doors.

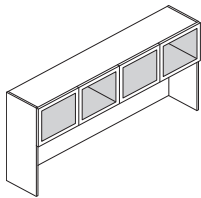

Stack-on Storage, Frosted Doors with Silver Frame

78"W x 15"D x 35¼"H — 4 doors, 2 compartments
 72"W x 15"D x 35¼"H — 4 doors, 2 compartments
 66"W x 15"D x 35¼"H — 4 doors, 2 compartments
 60"W x 15"D x 35¼"H — 4 doors, 2 compartments
 48"W x 15"D x 35¼"H — 3 doors, 2 compartments
 42"W x 15"D x 35¼"H — 2 doors, 1 compartment
 36"W x 15"D x 35¼"H — 2 doors, 1 compartment

HNL3678FD	153	31.8	\$2000	\$45	N/A
HNL3672FD	143	29.0	\$1944	\$35	N/A
HNL3666FD	134	26.7	\$1926	\$35	N/A
HNL3660FD	124	24.3	\$1813	\$35	N/A
HNL3648FD	104	19.6	\$1538	\$30	N/A
HNL3642FD	89	18.1	\$1353	\$30	N/A
HNL3636FD	79	15.3	\$1193	\$30	N/A

! Frosted/silver door units do not have a lock option.

NOTES:

- Convenient off-the-worksurface storage requires no additional floor space.
- 35¼"H stack-on storage models ship fully assembled.
- Fully enclosed back provides privacy; includes a 1¼", full-width pass-through for 3-prong electrical plugs; facilitates routing cords and reaching wall electrical outlets.
- Lower back panel can be attached with cord pass-through at bottom next to the worksurface or at top for close proximity to task light cord.
- Lower back panel can be removed to facilitate collaboration in teaming configurations.
- Valance hides task light.
- Vertical clearance for computer monitor is 20".
- Laminate vertical paper organizer (HLVPMI) sized to fit below storage compartments.
- Can be specified in seven widths (36", 42", 48", 60", 66", 72", and 78"W) and two heights, standard (35¼"H) or executive (48⅝"H).
- Available with laminate doors, frosted/silver doors, or sliding door.
- Doors are sized to overlap the top, end panels and light valance, to provide a clean design.
- Laminate and frosted/silver door units are equipped with self-closing, adjustable hinges.
- Laminate hinged door units are available with or without a lock.
- For tackboards, see page 59.
- For task lights, see page 113.
- For paper organizers, see page 110.

HOW TO SPECIFY

<p>Select Model Number</p> <p>H N L 3 6 7 2 L D</p>	<p>Select Chassis Color</p> <p>See page 29</p> <p>H</p>	<p>Select Door Front Color</p> <p>See page 29</p> <p>H</p>	
<p>Select Model Number</p> <p>H N L 3 6 7 2 L L</p>	<p>Select Lock Finish</p> <p>See page 29</p> <p>P</p>	<p>Select Chassis Color</p> <p>See page 29</p> <p>H</p>	<p>Select Door Front Color</p> <p>See page 29</p> <p>H</p>
<p>Select Model Number</p> <p>H N L 3 6 7 2 F D</p>	<p>Select Chassis Color</p> <p>See page 29</p> <p>H</p>		

CONCINNITY™

Stack-on Storage

GSA SIN 33721

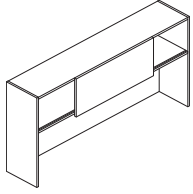

Icon Legend on page 19

**DESCRIPTION****Stack-on Storage, Sliding Door**

78"W x 15"D x 35¼"H
 72"W x 15"D x 35¼"H
 66"W x 15"D x 35¼"H
 60"W x 15"D x 35¼"H
 48"W x 15"D x 35¼"H

MODEL

HNL3678SD
HNL3672SD
HNL3666SD
HNL3660SD
HNL3648SD

SHIP WEIGHT

161
 151
 141
 131
 110

CUBE

31.8
 29.0
 26.7
 24.3
 19.6

L1 LIST

\$1293
\$1254
\$1156
\$1124
\$1063

L2 UPCHARGES

CHASSIS	FRONTS
\$45	\$20
\$35	\$20
\$35	\$20
\$35	\$20
\$30	\$20

NOTES: Sliding door units have one door per cabinet; standard with black lock, which is located on inside vertical support panel. Lock is core removable. Keyed alike cores must be ordered separately. For stack-on and wall mount storage with sliding door, specify model HF27B (Black) and the key number, see page 112. Sliding door availability limited to select sizes.

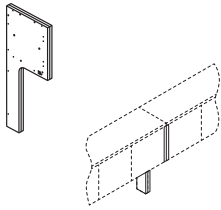
**Stack-on Space Saver End Panels**

¾"W x 14¼"D x 35¼"H

HNL3605SSEP

14

1.7

\$388**\$15****N/A**

NOTES: Two field installable end panels (1-right; 1-left) for use in ganging two stack-on storage units. Combining stack-on allows users to span longer worksurfaces, including 84" (2 - 42"W), 96" (2 - 48"W), 120" (2 - 60"W), and 144" (2 - 72"W). Narrow, space-saving panel size replaces the full 15"D end panels to expand worksurface space. The 4¼" right end panel is to replace the standard 15"D right end panel on one stack-on storage unit, the 4¼" left end panel is to replace the standard 15"D left end panel on a separate, adjacent stack-on storage unit that is in linear alignment with the first unit. Kit includes: (2) narrow end panel supports; European-style fasteners; dowels; joint connector bolts with sleeve nuts (for ganging stack-on storage units). Can be used to connect up to two stack-on storage units in a line (requires 1 kit). Can be specified in a woodgrain or solid laminate color only.

SPECIFYING EXAMPLE: HNL3605SSEP.H

NOTES:

- Convenient off-the-worksurface storage requires no additional floor space.
- 35¼"H stack-on storage models ship fully assembled.
- Fully enclosed back provides privacy; includes a 1¼", full-width pass-through for 3-prong electrical plugs; facilitates routing cords and reaching wall electrical outlets.
- Lower back panel can be attached with cord pass-through at bottom next to the worksurface or at top for close proximity to task light cord.
- Lower back panel can be removed to facilitate collaboration in teaming configurations.
- Valance hides task light.
- Vertical clearance for computer monitor is 20".
- Laminate vertical paper organizer (HLVPM1) sized to fit below storage compartments.
- Can be specified in seven widths (36", 42", 48", 60", 66", 72", and 78"W) and two heights, standard (35¼"H) or executive (48⅝"H).
- Available with laminate doors, frosted/silver doors, or sliding door.
- Doors are sized to overlap the top, end panels and light valance, to provide a clean design.
- Laminate and frosted/silver door units are equipped with self-closing, adjustable hinges.
- Laminate hinged door units are available with or without a lock.
- For tackboards, see page 59.
- For task lights, see page 113.
- For paper organizers, see page 110.

HOW TO SPECIFY**Select Model Number**

H N L 3 6 7 2 S D

Select Chassis Color

See page 29

H

Select Door Front Color

See page 29

H



CONCINNITY™ Stack-on Storage

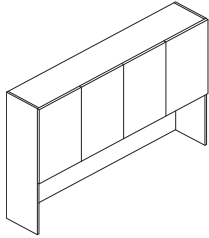

DESCRIPTION

Stack-on Storage, Laminate Doors
 78"W x 15"D x 48 5/8"H — 4 doors, 2 compartments
 72"W x 15"D x 48 5/8"H — 4 doors, 2 compartments
 66"W x 15"D x 48 5/8"H — 4 doors, 2 compartments
 60"W x 15"D x 48 5/8"H — 4 doors, 2 compartments
 48"W x 15"D x 48 5/8"H — 3 doors, 2 compartments
 42"W x 15"D x 48 5/8"H — 2 doors, 1 compartment
 36"W x 15"D x 48 5/8"H — 2 doors, 1 compartment

MODEL	SHIP WEIGHT	CUBE	L1 LIST	L2 UPCHARGES	
				CHASSIS	FRONTS
HNL4978LD	264	31.3	\$1820	\$60	\$20
HNL4972LD	243	29.1	\$1675	\$50	\$20
HNL4966LD	229	26.8	\$1583	\$50	\$20
HNL4960LD	212	24.5	\$1472	\$50	\$20
HNL4948LD	175	26.4	\$1404	\$45	\$20
HNL4942LD	149	23.2	\$1231	\$45	\$20
HNL4936LD	145	20.3	\$1191	\$45	\$20

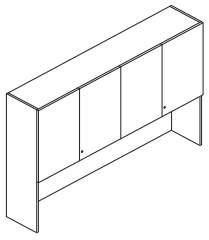

Stack-on Storage, Laminate Locking Doors
 78"W x 15"D x 48 5/8"H — 4 doors, 2 compartments
 72"W x 15"D x 48 5/8"H — 4 doors, 2 compartments
 66"W x 15"D x 48 5/8"H — 4 doors, 2 compartments
 60"W x 15"D x 48 5/8"H — 4 doors, 2 compartments
 48"W x 15"D x 48 5/8"H — 3 doors, 2 compartments
 42"W x 15"D x 48 5/8"H — 2 doors, 1 compartment
 36"W x 15"D x 48 5/8"H — 2 doors, 1 compartment

HNL4978LL	264	31.3	\$1904	\$60	\$20
HNL4972LL	243	29.1	\$1759	\$50	\$20
HNL4966LL	229	26.8	\$1667	\$50	\$20
HNL4960LL	212	24.5	\$1556	\$50	\$20
HNL4948LL	175	26.4	\$1467	\$45	\$20
HNL4942LL	149	23.2	\$1273	\$45	\$20
HNL4936LL	145	20.3	\$1233	\$45	\$20

! Lock available in Black (P) or Satin (SA) finish. Lock is core removable. Keyed alike cores must be ordered separately. For stack-on and wall mount storage with locking hinged doors, specify model HF27B (Black) or HF27S (Satin) and the key number, see page 112. Model HNL4948LL has one lock, which secures two of the three doors.

NOTES:

- Convenient off-the-worksurface storage requires no additional floor space.
- 48 5/8"H units have a fixed, intermittent shelf; storage space above and below the shelf is 12 5/8".
- Product applications are detailed on pages 53-54.
- Fully enclosed back provides privacy; includes a 1 1/4", full-width pass-through for 3-prong electrical plugs; facilitates routing cords and reaching wall electrical outlets.
- Lower back panel can be attached with cord pass-through at bottom next to the worksurface or at top for close proximity to task light cord.
- Lower back panel can be removed to facilitate collaboration in teaming configurations.
- Valance hides task light.
- Vertical clearance for computer monitor is 20".
- Laminate vertical paper organizer (HLVPMI) sized to fit below storage compartments.
- Can be specified in seven widths (36", 42", 48", 60", 66", 72", and 78"W) and two heights, standard (35 1/4"H) or executive (48 5/8"H).
- Available with laminate doors, frosted/silver doors, or sliding door.
- Doors are sized to overlap the top, end panels and light valance, to provide a clean design.
- Laminate and frosted/silver door units are equipped with self-closing, adjustable hinges.
- Laminate hinged door units are available with or without a lock.
- For tackboards, see page 59.
- For task lights, see page 113.
- For paper organizers, see page 110.

HOW TO SPECIFY

<p>Select Model Number</p> <p>H N L 4 9 7 8 L D</p>	<p>Select Chassis Color</p> <p>See page 29</p> <p>H</p>	<p>Select Door Front Color</p> <p>See page 29</p> <p>H</p>	
<p>Select Model Number</p> <p>H N L 4 9 7 8 L L</p>	<p>Select Lock Finish</p> <p>See page 29</p> <p>P</p>	<p>Select Chassis Color</p> <p>See page 29</p> <p>H</p>	<p>Select Door Front Color</p> <p>See page 29</p> <p>H</p>

CONCINNITY™

Stack-on Storage

GSA SIN 33721



Icon Legend on page 19

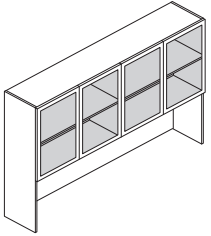

DESCRIPTION	MODEL	SHIP WEIGHT	CUBE	L1 LIST	L2 UPCHARGES	
					CHASSIS	FRONTS
Stack-on Storage, Frosted Doors with Silver Frame						
78"W x 15"D x 48 $\frac{5}{8}$ "H — 4 doors, 2 compartments	HNL4978FD	225	31.3	\$2794	\$60	N/A
72"W x 15"D x 48 $\frac{5}{8}$ "H — 4 doors, 2 compartments	HNL4972FD	207	29.1	\$2648	\$50	N/A
66"W x 15"D x 48 $\frac{5}{8}$ "H — 4 doors, 2 compartments	HNL4966FD	196	26.8	\$2556	\$50	N/A
60"W x 15"D x 48 $\frac{5}{8}$ "H — 4 doors, 2 compartments	HNL4960FD	182	24.5	\$2443	\$50	N/A
48"W x 15"D x 48 $\frac{5}{8}$ "H — 3 doors, 2 compartments	HNL4948FD	152	26.4	\$2136	\$45	N/A
42"W x 15"D x 48 $\frac{5}{8}$ "H — 2 doors, 1 compartment	HNL4942FD	128	23.2	\$1722	\$45	N/A
36"W x 15"D x 48 $\frac{5}{8}$ "H — 2 doors, 1 compartment	HNL4936FD	114	20.3	\$1681	\$45	N/A

Frosted/silver door units do not have a lock option.

NOTES:

- Convenient off-the-worksurface storage requires no additional floor space.
- 48 $\frac{5}{8}$ "H units have a fixed, intermittent shelf; storage space above and below the shelf is 12 $\frac{5}{8}$ ".
- Product applications are detailed on pages 53-54.
- Fully enclosed back provides privacy; includes a 1 $\frac{1}{4}$ ", full-width pass-through for 3-prong electrical plugs; facilitates routing cords and reaching wall electrical outlets.
- Lower back panel can be attached with cord pass-through at bottom next to the worksurface or at top for close proximity to task light cord.
- Lower back panel can be removed to facilitate collaboration in teaming configurations.
- Valance hides task light.
- Vertical clearance for computer monitor is 20".
- Laminate vertical paper organizer (HLVPM1) sized to fit below storage compartments.
- Can be specified in seven widths (36", 42", 48", 60", 66", 72", and 78"W) and two heights, standard (35 $\frac{1}{4}$ "H) or executive (48 $\frac{5}{8}$ "H).
- Available with laminate doors, frosted/silver doors, or sliding door.
- Doors are sized to overlap the top, end panels and light valance, to provide a clean design.
- Laminate and frosted/silver door units are equipped with self-closing, adjustable hinges.
- Laminate hinged door units are available with or without a lock.
- For tackboards, see page 59.
- For task lights, see page 113.
- For paper organizers, see page 110.

HOW TO SPECIFY

Select
Model Number

Select
Chassis Color

See page 29

H N L 4 9 7 8 F D . H



CONCINNITY™ Stack-on Storage

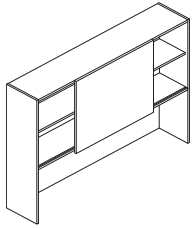

DESCRIPTION	MODEL	COM	SHIP WEIGHT	CUBE	L1 LIST	L2 UPCHARGES	
						CHASSIS	FRONTS
Stack-on Storage, Sliding Door							
78"W x 15"D x 48 ⁵ / ₈ "H	HNL4978SD		236	31.3	\$1847	\$60	\$20
72"W x 15"D x 48 ⁵ / ₈ "H	HNL4972SD		221	29.1	\$1747	\$50	\$20
66"W x 15"D x 48 ⁵ / ₈ "H	HNL4966SD		207	26.8	\$1708	\$50	\$20
60"W x 15"D x 48 ⁵ / ₈ "H	HNL4960SD		192	24.5	\$1505	\$50	\$20
48"W x 15"D x 48 ⁵ / ₈ "H	HNL4948SD		162	26.4	\$1434	\$45	\$20

NOTES: Sliding door units have one door per cabinet; standard with black lock, which is located on inside vertical support panel. Lock is core removable. Keyed alike cores must be ordered separately. For stack-on and wall mount storage with sliding door, specify model HF27B (Black) and the key number, see page 112. Sliding door availability limited to select sizes.

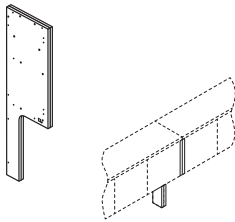

Stack-on Space Saver End Panels	HNL4905SSEP		23	2.2	\$523	\$15	N/A
--	--------------------	--	----	-----	--------------	-------------	------------

NOTES: Two field installable end panels (1-right; 1-left) for use in ganging two stack-on storage units. Combining stack-on allows users to span longer worksurfaces, including 84" (2 - 42"W), 96" (2 - 48"W), 120" (2 - 60"W), and 144" (2 - 72"W). Narrow, space-saving panel size replaces the full 15"D end panels to expand worksurface space. The 4¹/₄" right end panel is to replace the standard 15"D right end panel on one stack-on storage unit, the 4¹/₄" left end panel is to replace the standard 15"D left end panel on a separate, adjacent stack-on storage unit that is in linear alignment with the first unit. Kit includes: (2) narrow end panel supports; European-style fasteners; dowels; joint connector bolts with sleeve nuts (for ganging stack-on storage units). Can be used to connect up to two stack-on storage units in a line (requires 1 kit). Can be specified in a woodgrain or solid laminate color only.

SPECIFYING EXAMPLE: HNL4905SSEP.H

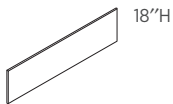

Tackboards for use with Stack-on Storage							
75"W - for 78"W	H90057	3.0	13	3.2	\$317	N/A	N/A
68 ³ / ₄ "W - for 72"W	H90056	2.0	12	2.7	\$301	N/A	N/A
62 ³ / ₄ "W - for 66"W	H90055	2.0	11	2.5	\$286	N/A	N/A
56 ³ / ₄ "W - for 60"W	H90054	2.0	10	2.2	\$252	N/A	N/A
44 ³ / ₄ "W - for 48"W	H90053	2.0	8	1.8	\$242	N/A	N/A
39"W - for 42"W	H90052	2.0	7	1.6	\$223	N/A	N/A
33"W - for 36"W	H90051	1.0	6	1.4	\$196	N/A	N/A
26 ³ / ₄ "W	H90050	1.0	5	1.2	\$196	N/A	N/A

NOTES: Specify fabric, see pages 25-26. Upcharges may apply to premium fabric grades.

Disperse (DISP) fabric not available on sizes wider than 60". Analog (ANLG) and Exchange (EXG) not available on sizes wider than 72".

SPECIFYING EXAMPLE: H90057.APN15

NOTES:

- Convenient off-the-worksurface storage requires no additional floor space.
- 48⁵/₈"H units have a fixed, intermittent shelf; storage space above and below the shelf is 12⁵/₈".
- Fully enclosed back provides privacy; includes a 1¹/₄", full-width pass-through for 3-prong electrical plugs; facilitates routing cords and reaching wall electrical outlets.
- Lower back panel can be attached with cord pass-through at bottom next to the worksurface or at top for close proximity to task light cord.
- Lower back panel can be removed to facilitate collaboration in teaming configurations.
- Valance hides task light.
- Vertical clearance for computer monitor is 20".
- Laminate vertical paper organizer (HLVPM1) sized to fit below storage compartments.
- Can be specified in seven widths (36", 42", 48", 60", 66", 72", and 78"W) and two heights, standard (35¹/₄"H) or executive (48⁵/₈"H).
- Available with laminate doors, frosted/silver doors, or sliding door.
- Doors are sized to overlap the top, end panels and light valance, to provide a clean design.
- Laminate and frosted/silver door units are equipped with self-closing, adjustable hinges.
- Laminate hinged door units are available with or without a lock.
- For tackboards, see above.
- For task lights, see page 113.
- For paper organizers, see page 110.

HOW TO SPECIFY

Select Model Number H N L 4 9 7 8 S D	Select Chassis Color See page 29 H	Select Door Front Color See page 29 H
---	---	--

CONCINNITY™ WALL MOUNT STORAGE APPLICATIONS

- Installation (review carefully):
 - **Attachment requires individual cabinets be secured by a minimum of two (2) wall mounting locations/studs.**
 - **Designed for interior and perimeter walls that are constructed with wood or metal studs.**
 - **Attaches to wall with horizontally mounted, interlocking brackets.**
 - **The HON Company is not responsible for any liabilities resulting from wall mounted storage cabinets that are not properly installed.**
- Laminate, laminate locking, and frosted/silver door units can be specified in eight widths (30", 36", 42", 48", 60", 66", 72", and 78"W) and two heights, standard (15"H) or executive (29½"H).
- Sliding door units can be specified in five widths (48", 60", 66", 72", and 78"W) and two heights, standard (15"H) or executive (29½"H).
- Product placement can be aligned to match the height of 64¾"H or 78⅛"H storage- and wardrobe-type cabinets.
- Available with laminate doors, frosted/silver doors, or sliding door.
 - Door design overlaps end panels so that when multiple units are placed side-by-side they appear as one continuous unit.
 - Laminate and frosted/silver door units are equipped with self-closing, adjustable hinges.
 - Laminate hinged door units are available with or without a lock.
 - Lock available in Black (P) or Satin (SA).
 - Lock is core removable; keyed alike cores must be ordered separately — for overhead storage with hinged doors specify model HF27B or HF27S and the key number.
 - Frosted/silver hinged door units do not have a lock option.
 - Sliding door units have one door per cabinet; standard with black lock, which is located on inside vertical support panel. Lock is core removable; keyed alike cores must be ordered separately — for overhead storage with a sliding door specify model HF23B (Black) and the key number.
 - Laminate and frosted/silver door cabinets in 30", 36", and 42"W have two doors; 48"W has three doors; 60", 66", 72", and 78"W have four doors.
- Inside storage dimensions of 15"H cabinets:
 - 30"W = one compartment, sized 28⅜"W x 13⅜"D x 12¾"H
 - 36"W = one compartment, sized 34⅜"W x 13⅜"D x 12¾"H
 - 42"W = one compartment, sized 40⅜"W x 13⅜"D x 12¾"H
 - 48"W = two compartments, one sized 30⅝"W x 13⅜"D x 12¾"H; one sized 14⅝"W x 13⅜"D x 12¾"H
 - 60"W = two compartments, each 28⅝"W x 13⅜"D x 12¾"H
 - 66"W = two compartments, each 31⅝"W x 13⅜"D x 12¾"H
 - 72"W = two compartments, each 34⅝"W x 13⅜"D x 12¾"H
 - 78"W = two compartments, each 37⅝"W x 13⅜"D x 12¾"H
- 28½"H units have a fixed, intermittent shelf; storage space above and below the shelf is 12⅝".
- Wall mounted storage cabinets are not designed for attachment to O-leg models HLSL65OS or HLSL50OS.
- Horizontal interlocking rails are included; due to varying types of walls, installers are responsible for selecting and supplying the appropriate fasteners.
- Ship fully assembled.

CONCINNITY™ WALL MOUNT STORAGE APPLICATIONS

OPTIONS INCLUDE:

- Door/Storage Options:

Door(s)	Standard-Height	Executive-Height
Laminate	•	•
Laminate Locking	•	•
Frosted/Silver	•	•
Sliding	48"-78"W only	48"-78"W only

- Paper organizers for stack-on and wall mounted storage cabinets (see compatibility information on page 111).
- Fabric-Covered Tackboards:
 - Tackboards mount directly to wall using the fasteners or hook-and-loop tape provided.
 - For a list of standard fabrics, see pages 25-26. For a complete list of fabrics, please go to hon.com/fabricsandfinishes.
 - See compatibility cross reference below.
 - NOTE: Tackboard widths differ slightly from the wall mounted storage cabinet widths. For applications where multiple wall mounted storage units are placed side-by-side, the preferred tackboard solution may be to utilize a larger tackboard size.
For example, H90057 = 75"W; H90056 = 68³/₄"W; H90055 = 62³/₄"W; H90054 = 56³/₄"W.
- Markerboards:
 - HL1530SOMB: 29¹/₂"W x 12¹/₂"H panel attaches to 60" and 66"W stack-on and wall mounted storage with sliding door models with double-sided tape.
 - HL1536SOMB: 35¹/₂"W x 12¹/₂"H panel attaches to 72" and 78"W stack-on and wall mounted storage with sliding door models with double-sided tape.
- Task Lights:
 - Attach to underside of stack-on and wall mount storage cabinets.
 - Fluorescent or LED options.
 - Compatibility: Tackboard and task light solutions, by model, for each wall mounted storage cabinet size:

Wall Mounted Storage	Tackboard	Fluorescent Task Light	LED Task Light
78"W	H90057 (75"W) or qty 2 of H90052 (39"W ea.)	HH870960, HH870960CH	HLED31A, HLED31AUO
72"W	H90056 (71 ¹ / ₂ "W)	HH870960, HH870960CH	HLED31A, HLED31AUO
66"W	H90055 (65 ¹⁵ / ₁₆ "W)	HH870960, HH870960CH	HLED31A, HLED17AUO
60"W	H90054 (59 ¹⁵ / ₁₆ "W)	HH870960, HH870960CH	HLED31A, HLED17AUO
48"W	H90053 (44 ³ / ₄ "W)	HH870942, HH870942CH	HLED31AS
42"W	H90052 (39"W)	HH870942, HH870942CH	HLED31AS
36"W	H90051 (33"W)	HH870930, HH870930CH	HLED17AS
30"W	H90050 (26 ³ / ₄ "W)	HH870930, HH870930CH	HLED17AS

CONCINNITY™

Wall Mount Storage

GSA SIN 33721

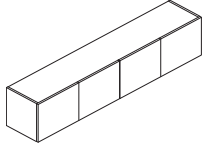

Icon Legend on page 19

**DESCRIPTION****Wall Mount Storage, Laminate Doors**

78"W x 15"D x 15"H — 4 doors, 2 compartments
 72"W x 15"D x 15"H — 4 doors, 2 compartments
 66"W x 15"D x 15"H — 4 doors, 2 compartments
 60"W x 15"D x 15"H — 4 doors, 2 compartments
 48"W x 15"D x 15"H — 3 doors, 2 compartments
 42"W x 15"D x 15"H — 2 doors, 1 compartment
 36"W x 15"D x 15"H — 2 doors, 1 compartment
 30"W x 15"D x 15"H — 2 doors, 1 compartment

MODEL**SHIP WEIGHT****CUBE****L1 LIST****L2 UPCHARGES**
CHASSIS FRONTS

HNL1578LD	126	17.1	\$1270	\$35	\$20
HNL1572LD	118	15.9	\$1180	\$25	\$20
HNL1566LD	109	14.6	\$1124	\$25	\$20
HNL1560LD	100	13.3	\$1009	\$25	\$20
HNL1548LD	83	10.9	\$910	\$20	\$20
HNL1542LD	68	9.7	\$860	\$20	\$10
HNL1536LD	60	8.4	\$785	\$20	\$10
HNL1530LD	51	7.2	\$725	\$20	\$10

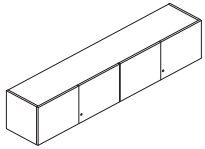
**Wall Mount Storage, Laminate Locking Doors**

78"W x 15"D x 15"H — 4 doors, 2 compartments
 72"W x 15"D x 15"H — 4 doors, 2 compartments
 66"W x 15"D x 15"H — 4 doors, 2 compartments
 60"W x 15"D x 15"H — 4 doors, 2 compartments
 48"W x 15"D x 15"H — 3 doors, 2 compartments
 42"W x 15"D x 15"H — 2 doors, 1 compartment
 36"W x 15"D x 15"H — 2 doors, 1 compartment
 30"W x 15"D x 15"H — 2 doors, 1 compartment

HNL1578LL	126	17.1	\$1354	\$35	\$20
HNL1572LL	118	15.9	\$1264	\$25	\$20
HNL1566LL	109	14.6	\$1208	\$25	\$20
HNL1560LL	100	13.3	\$1093	\$25	\$20
HNL1548LL	83	10.9	\$973	\$20	\$20
HNL1542LL	68	9.7	\$902	\$20	\$10
HNL1536LL	60	8.4	\$827	\$20	\$10
HNL1530LL	51	7.2	\$767	\$20	\$10

! Lock available in Black (P) or Satin (SA) finish. Lock is core removable. Keyed alike cores must be ordered separately. For stack-on and wall mount storage with locking hinged doors, specify model HF27B (Black) or HF27S (Satin) and the key number, see page 112. Model HNL1548LL has one lock, which secures two of the three doors.

NOTES:

- Convenient off-the-worksurface storage requires no additional floor space.
- Available with laminate doors, frosted/silver doors, or sliding door.
- Doors are sized to overlap the top, end panels and light valance, to provide a clean design.
- Laminate and frosted/silver door units are equipped with self-closing, adjustable hinges.
- Laminate hinged door units are available with or without a lock.
- For tackboards, see page 65.
- For task lights, see page 113.
- For paper organizers, see page 110.
- **IMPORTANT: See installation guidelines at top of page 60.**

HOW TO SPECIFY**Select Model Number**

H N L 1 5 7 8 L D

Select Chassis Color

See page 29

H

Select Door Front Color

See page 29

H

Select Model Number

H N L 1 5 7 8 L L

Select Lock Finish

See page 29

P

Select Chassis Color

See page 29

H

Select Door Front Color

See page 29

H



CONCINNITY™ Wall Mount Storage

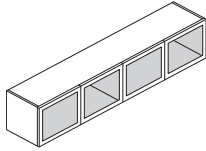

DESCRIPTION

Wall Mount Storage, Frosted Doors with Silver Frame

- 78"W x 15"D x 15"H — 4 doors, 2 compartments
- 72"W x 15"D x 15"H — 4 doors, 2 compartments
- 66"W x 15"D x 15"H — 4 doors, 2 compartments
- 60"W x 15"D x 15"H — 4 doors, 2 compartments
- 48"W x 15"D x 15"H — 3 doors, 2 compartments
- 42"W x 15"D x 15"H — 2 doors, 1 compartment
- 36"W x 15"D x 15"H — 2 doors, 1 compartment
- 30"W x 15"D x 15"H — 2 doors, 1 compartment

MODEL

SHIP WEIGHT

CUBE

L1 LIST

L2 UPCHARGES
CHASSIS FRONTS

HNL1578FD	106	17.1	\$1921	\$35	N/A
HNL1572FD	99	15.9	\$1829	\$25	N/A
HNL1566FD	92	14.6	\$1773	\$25	N/A
HNL1560FD	85	13.3	\$1657	\$25	N/A
HNL1548FD	71	10.9	\$1397	\$20	N/A
HNL1542FD	57	9.7	\$1187	\$20	N/A
HNL1536FD	50	8.4	\$1112	\$20	N/A
HNL1530FD	43	7.2	\$1051	\$20	N/A

❗ Frosted door models do not have a lock option.

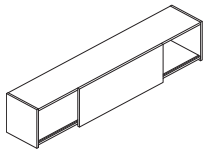

Wall Mount Storage, Sliding Door

- 78"W x 15"D x 15"H
- 72"W x 15"D x 15"H
- 66"W x 15"D x 15"H
- 60"W x 15"D x 15"H
- 48"W x 15"D x 15"H

HNL1578SD	114	17.1	\$1236	\$35	\$20
HNL1572SD	107	15.9	\$1135	\$25	\$20
HNL1566SD	99	14.6	\$1058	\$25	\$20
HNL1560SD	91	13.3	\$961	\$25	\$20
HNL1548SD	76	10.9	\$900	\$20	\$20

NOTES: One door per unit. Standard with black lock, which is located on the inside vertical support panel. Lock is core removable. Keyed alike cores must be ordered separately. For stack-on and wall mount storage with sliding door, specify model HF23B (Black) and the key number, see page 112.

NOTES:

- Convenient off-the-worksurface storage requires no additional floor space.
- Available with laminate doors, frosted/silver doors, or sliding door.
- Doors are sized to overlap the top, end panels and light valance, to provide a clean design.
- Laminate and frosted/silver door units are equipped with self-closing, adjustable hinges.
- Laminate hinged door units are available with or without a lock.
- For tackboards, see page 65.
- For task lights, see page 113.
- For paper organizers, see page 110.
- **IMPORTANT: See installation guidelines at top of page 60.**

HOW TO SPECIFY

<p>Select Model Number</p> <div style="border: 1px solid black; display: flex; justify-content: space-between; align-items: center; padding: 2px;"> HNL1578FD </div>	<p>Select Chassis Color</p> <p>See page 29</p> <div style="border: 1px solid black; display: flex; justify-content: space-between; align-items: center; padding: 2px;"> H </div>	
<p>Select Model Number</p> <div style="border: 1px solid black; display: flex; justify-content: space-between; align-items: center; padding: 2px;"> HNL1578SD </div>	<p>Select Chassis Color</p> <p>See page 29</p> <div style="border: 1px solid black; display: flex; justify-content: space-between; align-items: center; padding: 2px;"> H </div>	<p>Select Door Front Color</p> <p>See page 29</p> <div style="border: 1px solid black; display: flex; justify-content: space-between; align-items: center; padding: 2px;"> H </div>

CONCINNITY™

Wall Mount Storage

GSA SIN 33721

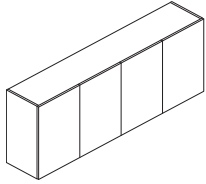

Icon Legend on page 19

**DESCRIPTION****Wall Mount Storage, Laminate Doors**

78"W x 15"D x 28½"H — 4 doors, 2 compartments
 72"W x 15"D x 28½"H — 4 doors, 2 compartments
 66"W x 15"D x 28½"H — 4 doors, 2 compartments
 60"W x 15"D x 28½"H — 4 doors, 2 compartments
 48"W x 15"D x 28½"H — 3 doors, 2 compartments
 42"W x 15"D x 28½"H — 2 doors, 1 compartment
 36"W x 15"D x 28½"H — 2 doors, 1 compartment
 30"W x 15"D x 28½"H — 2 doors, 1 compartment

MODEL**SHIP WEIGHT****CUBE****L1 LIST****L2 UPCHARGES**
CHASSIS FRONTS

HNL2978LD	213	30.8	\$1540	\$50	\$40
HNL2972LD	199	28.6	\$1460	\$40	\$40
HNL2966LD	185	26.4	\$1415	\$40	\$40
HNL2960LD	170	24.1	\$1314	\$40	\$40
HNL2948LD	142	19.7	\$1197	\$35	\$30
HNL2942LD	116	17.4	\$983	\$35	\$20
HNL2936LD	101	15.2	\$937	\$35	\$20
HNL2930LD	87	12.9	\$836	\$35	\$20

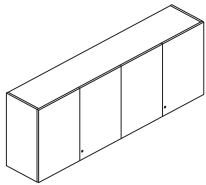
**Wall Mount Storage, Laminate Locking Doors**

78"W x 15"D x 28½"H — 4 doors, 2 compartments
 72"W x 15"D x 28½"H — 4 doors, 2 compartments
 66"W x 15"D x 28½"H — 4 doors, 2 compartments
 60"W x 15"D x 28½"H — 4 doors, 2 compartments
 48"W x 15"D x 28½"H — 3 doors, 2 compartments
 42"W x 15"D x 28½"H — 2 doors, 1 compartment
 36"W x 15"D x 28½"H — 2 doors, 1 compartment
 30"W x 15"D x 28½"H — 2 doors, 1 compartment

HNL2978LL	213	30.8	\$1624	\$50	\$40
HNL2972LL	199	28.6	\$1544	\$40	\$40
HNL2966LL	185	26.4	\$1499	\$40	\$40
HNL2960LL	170	24.1	\$1398	\$40	\$40
HNL2948LL	142	19.7	\$1260	\$35	\$30
HNL2942LL	116	17.4	\$1025	\$35	\$20
HNL2936LL	101	15.2	\$979	\$35	\$20
HNL2930LL	87	12.9	\$878	\$35	\$20

! Lock available in Black (P) or Satin (SA) finish. Lock is core removable. Keyed alike cores must be ordered separately. For stack-on and wall mount storage with locking hinged doors, specify model HF27B (Black) or HF27S (Satin) and the key number, see page 112. Model HNL2948LL has one lock, which secures two of the three doors.

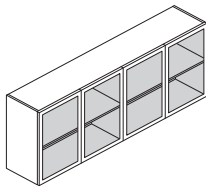
**Wall Mount Storage, Frosted Doors with Silver Frame**

78"W x 15"D x 28½"H — 4 doors, 2 compartments
 72"W x 15"D x 28½"H — 4 doors, 2 compartments
 66"W x 15"D x 28½"H — 4 doors, 2 compartments
 60"W x 15"D x 28½"H — 4 doors, 2 compartments
 48"W x 15"D x 28½"H — 3 doors, 2 compartments
 42"W x 15"D x 28½"H — 2 doors, 1 compartment
 36"W x 15"D x 28½"H — 2 doors, 1 compartment
 30"W x 15"D x 28½"H — 2 doors, 1 compartment

HNL2978FD	174	30.8	\$2512	\$50	N/A
HNL2972FD	163	28.6	\$2432	\$40	N/A
HNL2966FD	152	26.4	\$2386	\$40	N/A
HNL2960FD	140	24.1	\$2284	\$40	N/A
HNL2948FD	118	19.7	\$1927	\$35	N/A
HNL2942FD	94	17.4	\$1471	\$35	N/A
HNL2936FD	83	15.2	\$1425	\$35	N/A
HNL2930FD	72	12.9	\$1322	\$35	N/A

! Frosted door models do not have a lock option.

NOTES:

- Convenient off-the-worksurface storage requires no additional floor space.
- Available with laminate doors, frosted/silver doors, or sliding door.
- Doors are sized to overlap the top, end panels and light valance, to provide a clean design.
- Laminate and frosted/silver door units are equipped with self-closing, adjustable hinges.
- Laminate hinged door units are available with or without a lock.
- 28½"H units have a fixed, intermittent shelf; storage space above and below the shelf is 12½".
- For tackboards, see page 65.
- For task lights, see page 113.
- For paper organizers, see page 110.
- **IMPORTANT: See installation guidelines at top of page 60.**

HOW TO SPECIFY**Select Model Number**

H N L 2 9 7 8 L D

Select Chassis Color

See page 29

H

Select Door Front Color

See page 29

H

Select Model Number

H N L 2 9 7 8 L L

Select Lock Finish

See page 29

P

Select Chassis Color

See page 29

H

Select Door Front Color

See page 29

H

Select Model Number

H N L 2 9 7 8 F D

Select Chassis Color

See page 29

H



CONCINNITY™

Wall Mount Storage

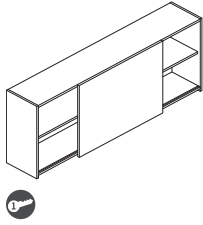

DESCRIPTION	MODEL	COM	SHIP WEIGHT	CUBE	L1 LIST	L2 UPCHARGES	
						CHASSIS	FRONTS
Wall Mount Storage, Sliding Door							
78"W x 15"D x 28½"H	HNL2978SD		189	30.8	\$1601	\$50	\$40
72"W x 15"D x 28½"H	HNL2972SD		177	28.6	\$1528	\$40	\$40
66"W x 15"D x 28½"H	HNL2966SD		165	26.4	\$1492	\$40	\$40
60"W x 15"D x 28½"H	HNL2960SD		153	24.1	\$1396	\$40	\$40
48"W x 15"D x 28½"H	HNL2948SD		129	19.7	\$1225	\$35	\$30

NOTES: One door per unit. Standard with black lock, which is located on the inside vertical support panel. Lock is core removable. Keyed alike cores must be ordered separately. For stack-on and wall mount storage with sliding door, specify model HF23B (Black) and the key number, see page 112.

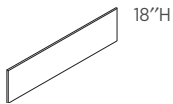

Tackboards for use with Wall Mount Storage

75"W - for 78"W	H90057	3.0	13	3.2	\$317	N/A	N/A
68¾"W - for 72"W	H90056	2.0	12	2.7	\$301	N/A	N/A
62¾"W - for 66"W	H90055	2.0	11	2.5	\$286	N/A	N/A
56¾"W - for 60"W	H90054	2.0	10	2.2	\$252	N/A	N/A
44¾"W - for 48"W	H90053	2.0	8	1.8	\$242	N/A	N/A
39"W - for 42"W	H90052	2.0	7	1.6	\$223	N/A	N/A
33"W - for 36"W	H90051	1.0	6	1.4	\$196	N/A	N/A
26¾"W	H90050	1.0	5	1.2	\$196	N/A	N/A

NOTES: Specify fabric, see pages 25-26. Upcharges may apply to premium fabric grades.

Tackboard widths differ slightly from the wall mounted storage cabinet widths. For applications where multiple wall mounted storage units are placed side-by-side, the preferred tackboard solution may be to utilize a larger tackboard size. For example, H90057 = 75"W;

H90056 = 68¾"W; H90055 = 62¾"W; H90054 = 56¾"W.

ⓘ Disperse (DISP) fabric not available on sizes wider than 60". Analog (ANLG) and Exchange (EXG) not available on sizes wider than 72".

SPECIFYING EXAMPLE: H90057.APN15

NOTES:

- Convenient off-the-worksurface storage requires no additional floor space.
- Valance hides task light.
- Available with laminate doors, frosted/silver doors, or sliding door.
- Doors are sized to overlap the top, end panels and light valance, to provide a clean design.
- Laminate and frosted/silver door units are equipped with self-closing, adjustable hinges.
- Laminate hinged door units are available with or without a lock.
- 28½"H units have a fixed, intermittent shelf; storage space above and below the shelf is 12⅝".
- For tackboards, see above.
- For task lights, see page 113.
- For paper organizers, see page 110.
- **IMPORTANT: See installation guidelines at top of page 60.**

HOW TO SPECIFY

Select Model Number See page 29 H N L 2 9 7 8 S D	Select Chassis Color See page 29 H	Select Door Front Color See page 29 H
---	--	---

CONCINNITY™ Bookcase Hutches

GSA SIN 33721



Icon Legend on page 19

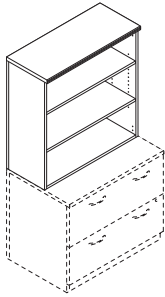

DESCRIPTION

Bookcase Hutch, No Doors/Open

36"W x 14 1/4"D x 35 1/4"H (shown)
30"W x 14 1/4"D x 35 1/4"H

36"W x 14 1/4"D x 48 5/8"H
30"W x 14 1/4"D x 48 5/8"H

MODEL

SHIP WEIGHT

CUBE

L1 LIST

**L2 UPCHARGES
CHASSIS FRONTS**

HNL3636BHxD	213	15.3	\$596	\$15	N/A
HNL3630BHxD	199	12.5	\$583	\$15	N/A
HNL4936BHxD	213	125.0	\$753	\$25	N/A
HNL4930BHxD	199	109.0	\$704	\$25	N/A

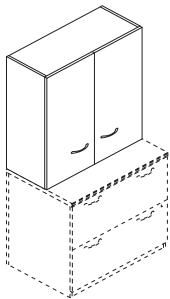

Bookcase Hutch, Laminate Doors

36"W x 15"D x 35 1/4"H (shown)
30"W x 15"D x 35 1/4"H

36"W x 15"D x 48 5/8"H
30"W x 15"D x 48 5/8"H

HNL3636BHLD
HNL3630BHLD

213
199

15.3
12.5

\$771
\$723

\$15
\$15

\$20
\$20

HNL4936BHLD
HNL4930BHLD

213
199

165.0
142.0

\$923
\$866

\$25
\$25

\$30
\$30

NOTES:

- Designed for use on worksurfaces, or on 30" or 36" W x 29 1/2" H lateral file or storage cabinet with doors.
- Two widths, 30" and 36"; two heights, 35 1/4" and 48 5/8".
- The 35 1/4" H unit has three shelves, two are adjustable in 1/4" increments with a total range of 17 1/2"; bottom shelf is fixed.
- The 48 5/8" H unit has four shelves, three are adjustable in 1/4" increments with a total range of 25"; bottom shelf is fixed.
- Available with laminate doors or frosted/silver doors or no doors (open).
- Door units equipped with self-closing, adjustable hinges.
- Laminate doors have decorative handles.
- Frosted door units have push/touch latch release.
- Doors are non-locking.
- To align with the top of the 35 1/4" H bookcase hutch, use 64 3/4" H floor-standing storage models; to align with the top of the 48 5/8" H bookcase hutch, use 78 3/8" H models.
- Ship fully assembled.

HOW TO SPECIFY

Select Model Number

H N L 3 6 3 6 B H X D .

Select Laminate Color

See page 29

H

Select Model Number

H N L 3 6 3 6 B H L D .

Select Handle

- A Cylinder - Satin
- B Cylinder - Black
- C Canopy - Satin
- D Canopy - Black
- E Loop - Satin
- F Loop - Black

E .

Select Chassis Color

See page 29

H .

Select Door Front Color

See page 29

H



CONCINNITY™ Bookcase Hutches

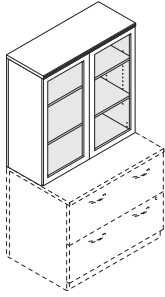

DESCRIPTION	MODEL	SHIP WEIGHT	CUBE	L1 LIST	L2 UPCHARGES	
					CHASSIS	FRONTS
Bookcase Hutch, Frosted Doors with Silver Frame 36"W x 15"D x 35¼"H (shown)	HNL3636BHFD	199	15.3	\$1416	\$15	N/A
36"W x 15"D x 48⅝"H	HNL4936BHFD	213	134.0	\$1729	\$25	N/A

NOTES:

- Designed for use on worksurfaces, or on 30" or 36"W x 29½"H lateral file or storage cabinet with doors.
- Two widths, 30" and 36"; two heights, 35¼" and 48⅝".
- The 35¼"H unit has three shelves, two are adjustable in 1¼" increments with a total range of 17½"; bottom shelf is fixed.
- The 48⅝"H unit has four shelves, three are adjustable in 1¼" increments with a total range of 25"; bottom shelf is fixed.
- Available with laminate doors or frosted/silver doors or no doors (open).
- Door units equipped with self-closing, adjustable hinges.
- Laminate doors have decorative handles.
- Frosted door units have push/touch latch release.
- Doors are non-locking.
- To align with the top of the 35¼"H bookcase hutch, use 64¾"H floor-standing storage models; to align with the top of the 48⅝"H bookcase hutch, use 78⅝"H models.
- Ship fully assembled.

HOW TO SPECIFY

Select
Model Number

H N L 3 6 3 6 B H F D .

Select
Chassis Color

See page 29

H

CONCINNITY™ Reception Stations

GSA SIN 33721



Icon Legend on page 19

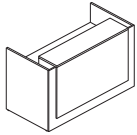

DESCRIPTION	MODEL	SHIP WEIGHT	CUBE	L1 LIST	L2 UPCHARGES		ACCENT PANEL
					WORKSURFACE	CHASSIS	

Reception Desk with Transaction Counter 72"W x 36 3/4"D x 44"H	HLAM3772RD	324	13.5	\$1474	\$35	\$70	\$25
--	-------------------	-----	------	---------------	-------------	-------------	-------------

NOTES: Non-handed. Counter measures 60"W x 15 1/4"D. Flat edge (G) matches 10500 Series™. For beaded (B) and tri-oval (V) edge shapes, the transaction counter is profiled on the approach and user sides, and the desk worksurface is profiled on the user's side. Beaded (B) and tri-oval (V) edges are available in L1 woodgrains colors only. Smooth and flat (G) edge available in all woodgrains and solid colors. Vertical grain on approach side and front accent panel for L1 laminates except Kingswood Walnut and Florence Walnut. Horizontal grain on L2 laminates and Kingswood and Florence Walnut. Vertical grain on end panels and horizontal grain on worksurface and transaction counter. Two worksurface cord management grommets for routing and hiding wires and cables; can be specified in Black (P) or Platinum (TI) finish.

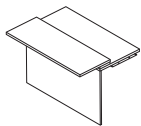

Reception Return with 32'H Transaction Counter 48 1/4"W x 32 7/8"D x 32"H	HLAM3348RR	145	3.7	\$829	\$35	\$35	N/A
---	-------------------	-----	-----	--------------	-------------	-------------	------------

NOTES: Non-handed. For use with HLAM3772RD and Reception Desk Shell (H105724). Counter facilitates accessibility; measures 48"W x 12"D x 32"H. Flat edge (G) matches 10500 Series™. For beaded (B) and tri-oval (V) edge shapes, the transaction counter is profiled on the approach side, and the return worksurface is profiled on the user's side. All other edges are flat banded. Beaded (B) and tri-oval (V) available in L1 woodgrain colors only. Flat edge (G) available in all woodgrains and solid colors. Pattern laminates do not have matching edge color; patterns can be specified with woodgrain or solid edge. Vertical grain on approach side, end panel, worksurface, and transaction counter. Assembly required.

Specify: Model.Edge Profile & EdgeColor.Worksurface & Counter Color.Chassis Color

SPECIFYING EXAMPLE: HLAM3348RR.GN.N.N

HOW TO SPECIFY

Select Model Number H L A M 3 7 7 2 R D .	Select Edge Profile and Edge Color See page 29 G N .	Select Grommet Color P Black TI Platinum Not specified for model HLAM3348RR P .	Select Worksurface Laminate See page 29 N .	Select Chassis Laminate See page 29 N .	Select Accent Panel Laminate See page 29 Not specified for model HLAM3348RR L D W 1
---	---	--	--	--	---

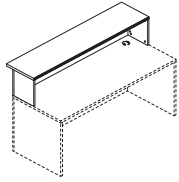

DESCRIPTION

Reception Station Counter for Desk
72"W x 17"D x 14 5/8"H

MODEL	SHIP WEIGHT	CUBE	L1 LIST	L2 UPCHARGES	
				COUNTER	CHASSIS
HNL1772RT	74	4.3	\$563	\$10	\$15

Compatible for use on 72"W x 30" or 36"D desktops and worksurfaces. For cleanest approach-side aesthetic, use on desk built with modular components; desk comprised of either 72"W x 30"D rectangle worksurface and 72"W x 27 7/8"H modesty/back panel, supported by 29 1/8"D pedestal(s) and/or end panel(s), or 72"W x 36"D worksurface and 72"W x 27 7/8"H modesty/back panel, supported by 35"D left and right end panels. The counter is 17"D with a 4" approach-side overhang; end panels are 12 3/8"D. Ships with Transaction counter organizer (model HTCOL52) is available as an option; fits under transaction counter; organizer is available in black only.

SPECIFYING EXAMPLE: HNL1772RT.BH.H.H

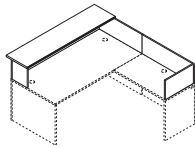

For Station with Right Return

L-Reception Station with Transaction Counter for Desk

72"W x 88"D x 14 5/8"H
72"W x 82"D x 14 5/8"H

HNL8472RT	103	4.5	\$900	\$10	\$25
HNL7872RT	101	4.5	\$877	\$10	\$25

NOTES: Intended for use on desk built with modular components, for clean approach-side aesthetic, connected to a return or modular return. Layout for 78" and 84"D footprints:

- 72"W x 78"D:
 - Desk = 72"W x 30"D worksurface, 72"W x 27 7/8"H modesty/back panel, supported by 29 1/8"D pedestal(s) and/or end panel(s).
 - Return = 48"W x 24"D return; or 48"W x 24"D worksurface with vertical grain, 48"W x 27 7/8"H modesty/back panel, supported by a 23 1/8"D pedestal and/or end panel.
- 72"W x 84"D:
 - Desk = 72"W x 36"D worksurface, 72"W x 27 7/8"H modesty/back panel, supported by 1-left and 1-right 35"D panel.
 - Return = 42"W x 24"D return; or 42"W x 24"D worksurface with vertical grain, 42"W x 27 7/8"H modesty/back panel, supported by a 23 1/8"D pedestal and/or end panel.
- 72"W x 88"D:
 - Desk = 72"W x 36"D worksurface, 72"W x 27 7/8"H modesty/back panel, supported by 1-left and 1-right 35"D end panel.
 - Return = 48"W x 24"D return; or 48"W x 24"D worksurface with vertical grain, 48"W x 27 7/8"H modesty/back panel, supported by a 23 1/8"D pedestal and/or end panel.

Comprised of 17"D transaction counter, with 4" approach-side overhang, for the desk and a vertical privacy panel extending the depth of the desk and width of the return. Ships with Transaction counter organizer (model HTCOL52) is available as an option; fits under transaction counter; organizer is available in black only.

SPECIFYING EXAMPLE: HNL8472RT.BH.H.H

NOTES:

- Reception Station Counter for Desk, and L-Reception Station with Transaction Counter for Desk, have profiled edgeband on the approach and user sides.
- L-Reception Station with Transaction Counter for Desk and Return has profiled edgeband on front side of transaction counter on desk approach-side only.
- For L-reception station layouts where the return is not against a wall, specify return using modular components, as the modesty/back panel can be specified without a grommet. Assembled returns come standard with cord grommet in modesty/back panel.

HOW TO SPECIFY

<p>Select Model Number</p> <p>H N L 1 7 7 2 R T</p>	<p>Select Edge Profile and Edge Color</p> <p>See page 29</p> <p>B H</p>	<p>Select Counter Color</p> <p>See page 29</p> <p>H</p>	<p>Select Chassis Color</p> <p>See page 29</p> <p>H</p>
--	--	--	--

CONCINNITY™

Reception Stations

GSA SIN 33721



Icon Legend on page 19

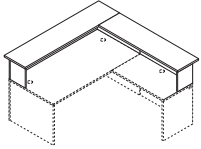

For Station with Right Return

DESCRIPTION	MODEL	SHIP WEIGHT	CUBE	L1 LIST	L2 UPCHARGES	
					COUNTER	CHASSIS
L-Reception Station with Transaction Counter for Desk and Return						
76"W x 88"D x 14 $\frac{5}{8}$ "H	HNL8472RLT	145	5.6	\$1077	\$10	\$25
76"W x 82"D x 14 $\frac{5}{8}$ "H	HNL7872RLT	139	5.6	\$1039	\$10	\$25
NOTES: Intended for use on desk built with modular components, for clean approach-side aesthetic, connected to a return or modular return. Layout for 78" and 84"D footprints:						
<ul style="list-style-type: none"> • 72"W x 78"D: <ul style="list-style-type: none"> - Desk = 72"W x 30"D worksurface, 72"W x 27$\frac{7}{8}$"H modesty/back panel, supported by 29$\frac{1}{8}$"D pedestal(s) and/or end panel(s). - Return = 48"W x 24"D worksurface with vertical grain, 48"W x 27$\frac{7}{8}$"H modesty/back panel, supported by a 23$\frac{1}{8}$"D pedestal and/or end panel. • 72"W x 78"D: <ul style="list-style-type: none"> - Desk = 72"W x 36"D worksurface, 72"W x 27$\frac{7}{8}$"H modesty/back panel, supported by 1-left and 1-right 35"D panel. - Return = 42"W x 24"D worksurface with vertical grain, 42"W x 27$\frac{7}{8}$"H modesty/back panel, supported by a 23$\frac{1}{8}$"D pedestal and/or end panel. • 72"W x 84"D: <ul style="list-style-type: none"> - Desk = 72"W x 36"D worksurface, 72"W x 27$\frac{7}{8}$"H modesty/back panel, supported by 1-left and 1-right 35"D end panel. - Return = 48"W x 24"D worksurface with vertical grain, 48"W x 27$\frac{7}{8}$"H modesty/back panel, supported by a 23$\frac{1}{8}$"D pedestal and/or end panel. 						
ⓘ The 17"D transaction counter, with 4" overhang, extends around the perimeter of the station, across the width of the desk, as well as along the depth of the desk and width of the return. Ships ⓘ. Transaction counter organizer (model HTCOL52) is available as an option; fits under transaction counter; organizer is available in black only.						
SPECIFYING EXAMPLE: HNL8472RLT.BH.H.H						

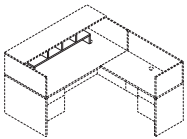

Transaction Counter Organizer						
48 $\frac{3}{4}$ "W x 11 $\frac{1}{8}$ "D x 13"H	HTCOL52	24	1.1	\$283	N/A	N/A
NOTES: Fits under reception station counters.						
ⓘ Black only.						
SPECIFYING EXAMPLE: HTCOL52.P						

NOTES:

- Reception Station Counter for Desk, and L-Reception Station with Transaction Counter for Desk, have profiled edgeband on the approach and user sides.
- ⓘ L-Reception Station with Transaction Counter for Desk and Return has profiled edgeband on front side of transaction counter on desk approach-side only.
- ⓘ For L-reception station layouts where the return is not against a wall, specify return using modular components, as the modesty/back panel can be specified without a grommet. Assembled returns come standard with cord grommet in modesty/back panel.

HOW TO SPECIFY

Select Model Number H N L 8 4 7 2 R L T .	Select Edge Profile and Edge Color See page 29 B H .	Select Counter Color See page 29 H .	Select Chassis Color See page 29 H
---	---	---	---



CONCINNITY™ Mobile Pedestals

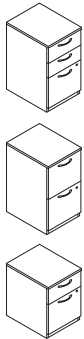

DESCRIPTION	MODEL	SHIP WEIGHT	CUBE	L1 LIST	L2 UPCHARGES		
					TOP	CHASSIS	FRONTS
Mobile Pedestal — 15¾" W							
15¾"W x 20⅞"D x 28⅜"H, Box/Box/File	HNL2116MBBF	69	7.4	\$916	N/A	\$20	\$10
15¾"W x 20⅞"D x 28⅜"H, File/File	HNL2116MFF	70	7.4	\$916	N/A	\$20	\$10
15¾"W x 20⅞"D x 21½"H, Box/File	HNL2116MBF	55	5.8	\$776	N/A	\$20	\$10

NOTES: Well suited to a variety of office layouts, including private, open floor plan, and cubicle workspaces. Design positions the center of gravity towards the back of the cabinet to inhibit tipping. All drawers lock; interchangeable core removable lock makes re-keying quick and easy. Finish of lock is determined by, and aligned with, the handle finish specified. Keyed alike cores must be ordered separately; specify model HF23B (Black) or HF23S (Satin) and specific key number required. Pedestals, excluding cushion option, are sized to be positioned under 29½"H worksurfaces. Seat cushion model HLSL2016PH2 is optional. Cushion adds 1" to the height of the pedestal. Box/File unit with cushion will fit below 29½"H worksurface. ¾" thick top with flat edgeband; back inside end panel construction. Ships fully assembled.

SPECIFYING EXAMPLE: HNL2116MBBF.E.H.H

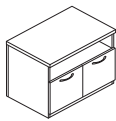

Mobile Pedestal — 30" W							
30"W x 20"D x 21½"H, Shelf/File/Cabinet	HNL2030MSFC	105	10.7	\$1152	\$10	\$25	\$15

NOTES: Sized to align with 20"D x 20½"H low credenzas. Open shelf over file drawer left and cabinet with door right. Design positions the center of gravity towards the back of the cabinet to inhibit tipping. Seat cushion model HNL2030CH2 is optional. Cushion adds 1" to the height of the pedestal. 1⅞" thick top matches low credenza design. Ships fully assembled.

SPECIFYING EXAMPLE: HNL2030MSFC.BH.E.H.H.H

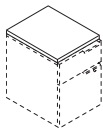

DESCRIPTION	MODEL	SHIP WEIGHT	CUBE	LIST PRICE BY FABRIC GRADE					
				1	2	3	4	5	6
Mobile Pedestal Cushion									
30"W x 20"D x 1"H	HLSL2030CH2	9	1.9	\$380	\$416	\$452	\$488	\$534	\$581
15¾"W x 20"D x 1"H	HLSL2016PH2	6	1.1	\$315	\$339	\$363	\$387	\$418	\$449

NOTES: See pages 22-24 for available fabrics.

SPECIFYING EXAMPLE: HLSL2016PH2.APN23

NOTES:

- Mobile pedestals roll easily on four casters to provide convenient, flexible placement of personal storage needs.
- Drawers operate on steel ball-bearing suspension with full extension.
- File drawers include hangrails for side-to-side letter and legal filing; and front-to-back for letter filing.
- ! 28⅜"H mobile pedestals are not designed for use with the 28½"H metal O-leg due to interference caused by (1) the O-leg worksurface attachment bracket, and (2) the external support channel on the underside of a 72", 66", and 60"W rectangle worksurface supported by O-leg(s).

HOW TO SPECIFY

<p>Select Model Number</p> <p>H N L 2 1 1 6 M B B F .</p>	<p>Select Handle</p> <p>A Cylinder – Satin B Cylinder – Black C Canopy – Satin D Canopy – Black E Loop – Satin F Loop – Black</p> <p>E .</p>	<p>Select Chassis Color</p> <p>See page 29</p> <p>H .</p>	<p>Select Drawer Front Color</p> <p>See page 29</p> <p>H</p>
--	---	--	---

<p>Select Model Number</p> <p>H N L 2 0 3 0 M S F C .</p>	<p>Select Edge Profile and Edge Color</p> <p>See page 29</p> <p>B H .</p>	<p>Select Handle</p> <p>A Cylinder – Satin B Cylinder – Black C Canopy – Satin D Canopy – Black E Loop – Satin F Loop – Black</p> <p>E .</p>	<p>Select Top Color</p> <p>See page 29</p> <p>H .</p>	<p>Select Chassis Color</p> <p>See page 29</p> <p>H .</p>	<p>Select Drawer/Door Front Color</p> <p>See page 29</p> <p>H</p>
--	--	---	--	--	--

CONCINNITY™ Lateral Files

GSA SIN 33721



Icon Legend on page 19

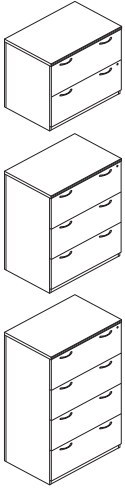

DESCRIPTION	MODEL	SHIP WEIGHT	CUBE	L1 LIST	L2 UPCHARGES		
					TOP	CHASSIS	FRONTS
Lateral File 36"W x 24"D x 59½"H, 4-Drawer	HNL2436LD4	276	34.3	\$2169	\$15	\$30	\$30
36"W x 24"D x 45½"H, 3-Drawer	HNL2436LD3	222	26.0	\$1798	\$15	\$25	\$25
36"W x 24"D x 29½"H, 2-Drawer	HNL2436LD2	178	18.4	\$1191	\$15	\$20	\$20

NOTES: Equipped with safety restraints; mechanical interlock inhibits the extension of more than one drawer at a time; counterweight positions the center of gravity towards the back of the cabinet to inhibit tipping. 24" depth aligns evenly with credenzas, returns, storage cabinet, storage/file cabinet, storage cabinet/lateral file, wardrobe/storage cabinet, wardrobe/bookcase, storage towers, and 24"D modular components. 29½"H unit is sized to accommodate 36"W stack-on storage or bookcase hutch options. Drawers lock; interchangeable core removable lock makes re-keying quick and easy. Finish of lock is determined by, and aligned with, the handle finish specified. Keyed alike cores must be ordered separately; specify model HF23B (Black) or HF23S (Satin) and specific key number required. Ship fully assembled. 30"W two-drawer size can be specified and assembled using modular components. Drawers include hangrails to accept folders in letter or legal size.

SPECIFYING EXAMPLE: HNL2436LD2.BH.E.H.H.H

HOW TO SPECIFY

<p>Select Model Number</p> <p>H N L 2 4 3 6 L D 4 .</p>	<p>Select Edge Profile and Edge Color</p> <p>See page 29</p> <p>B H .</p>	<p>Select Handle</p> <p>A Cylinder – Satin B Cylinder – Black C Canopy – Satin D Canopy – Black E Loop – Satin F Loop – Black</p> <p>E .</p>	<p>Select Top Color</p> <p>See page 29</p> <p>H .</p>	<p>Select Chassis Color</p> <p>See page 29</p> <p>H .</p>	<p>Select Drawer Front Color</p> <p>See page 29</p> <p>H .</p>
--	--	--	--	--	---



CONCINNITY™ Storage Cabinets

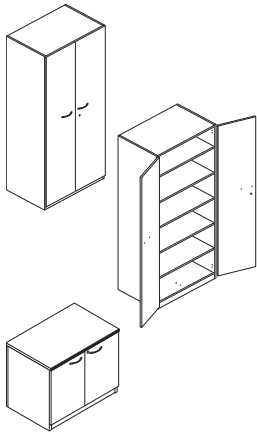

DESCRIPTION	MODEL	SHIP WEIGHT	CUBE	L1 LIST	L2 UPCHARGES		
					TOP	CHASSIS	FRONTS
Storage Cabinet with Laminate Doors							
36"W x 24"D x 78 ⁵ / ₈ "H (shown)	HNL243679SC	317	47.4	\$2347	N/A	\$60	\$25
36"W x 24"D x 64 ³ / ₄ "H	HNL243665SC	252	40.8	\$2208	N/A	\$55	\$20
36"W x 24"D x 29 ¹ / ₂ "H	HNL243629SC	158	18.4	\$1061	\$15	\$20	\$20

NOTES: 29¹/₂"H size has one adjustable interior shelf. Shelf adjusts in 2¹/₂" increments over a total range of 10"H, 64³/₄"H and 78⁵/₈"H have five shelves (four adjustable) and six shelves (five adjustable), respectively; shelves adjust in 2¹/₂" increments. Locking doors. 24" depth aligns evenly with credenzas, returns, lateral files, storage/file cabinet, storage cabinet/lateral file, wardrobe/storage cabinet, wardrobe/bookcase, storage tower, bookcase with coat hook, and 24"D modular components. 29¹/₂"H unit is sized to accommodate 36"W stack-on storage or bookcase hutch options. Ships fully assembled. 30"W x 24"D x 29¹/₂"H freestanding unit can be built using modular components.

SPECIFYING EXAMPLE (29¹/₂"H): HNL243629SC.BH.E.H.H.H

SPECIFYING EXAMPLE (64³/₄-78⁵/₈"H): HNL243665SC.E.H.H

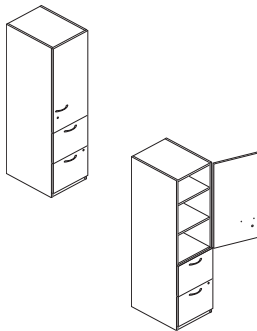

DESCRIPTION	MODEL	SHIP WEIGHT	CUBE	L1 LIST	L2 UPCHARGES TOP	L2 UPCHARGES CHASSIS	L2 UPCHARGES FRONTS
Storage/File Cabinet							
18"W x 24"D x 64 ³ / ₄ "H, File/File, Laminate Door Hinged Right (shown)	HNL241865SFLR	184	21.6	\$1775	N/A	\$25	\$15
18"W x 24"D x 64 ³ / ₄ "H, File/File, Laminate Door Hinged Left	HNL241865SFLL	184	21.6	\$1775	N/A	\$25	\$15
18"W x 24"D x 64 ³ / ₄ "H, File/File, Open Shelves	HNL241865SFX	169	21.6	\$1685	N/A	\$25	\$15

NOTES: Versatile unit features a storage cabinet plus two file drawers. Storage cabinet includes three shelves, two are adjustable; shelves adjust in 2¹/₂" increments. Can be specified with door hinged left, door hinged right, or no door/open shelves. File drawers operate on steel ball-bearing suspensions with full extension. File drawers include hangrails to accept folders in letter or legal size. Storage cabinet door and file drawers lock separately; the two locks are keyed alike. Unit height is designed to match desk, credenza, or return plus 35¹/₄"H stack-on storage (= 64³/₄"). Ships fully assembled.

SPECIFYING EXAMPLE (WITH DOOR): HNL241865SFLR.E.H.H

SPECIFYING EXAMPLE (WITHOUT DOOR): HNL241865SFX.E.H.H

NOTES:

- Interchangeable core removable lock makes re-keying quick and easy.
- Finish of lock is determined by, and aligned with, the handle finish specified.
- Keyed alike cores must be ordered separately; specify model HF23B (Black) or HF23S (Satin) and specific key number required.

HOW TO SPECIFY

<p>Select Model Number</p> <p>H N L 2 4 3 6 2 9 S C .</p>	<p>Select Edge Profile and Edge Color</p> <p>See page 29</p> <p>B H .</p>	<p>Select Handle</p> <p>A Cylinder - Satin B Cylinder - Black C Canopy - Satin D Canopy - Black E Loop - Satin F Loop - Black</p> <p>E .</p>	<p>Select Top Color</p> <p>See page 29</p> <p>H .</p>	<p>Select Chassis Color</p> <p>See page 29</p> <p>H .</p>	<p>Select Drawer Front Color</p> <p>See page 29</p> <p>H .</p>
--	--	---	--	--	---

<p>Select Model Number</p> <p>H N L 2 4 3 6 6 5 S C .</p> <p>H N L 2 4 1 8 6 5 S F X .</p>	<p>Select Handle</p> <p>A Cylinder - Satin B Cylinder - Black C Canopy - Satin D Canopy - Black E Loop - Satin F Loop - Black</p> <p>E .</p> <p>E .</p>	<p>Select Chassis Color</p> <p>See page 29</p> <p>H .</p> <p>H .</p>	<p>Select Drawer Front Color</p> <p>See page 29</p> <p>H .</p> <p>H .</p>
---	--	---	--

CONCINNITY™

Storage Cabinets

GSA SIN 33721



Icon Legend on page 19

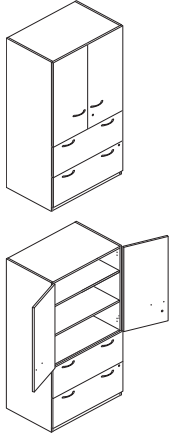

DESCRIPTION	MODEL	SHIP WEIGHT	CUBE	L1 LIST	L2 UPCHARGES		
					TOP	CHASSIS	FRONTS
Storage Cabinet/Lateral File, Laminate Doors 36"W x 24"D x 64¾"H	HNL243665SLL	328	40.8	\$2381	N/A	\$55	\$20

NOTES: Cabinet includes one fixed and two full-width adjustable shelves; adjustable shelves can be removed. Overall storage compartment measures 34"W x 22"D x 34½"H and will accommodate supplies, books and binders. Lateral file equipped with mechanical interlock to inhibit the extension of more than one drawer at a time. Lateral file drawers include hangrails to accept folders in letter or legal size. Storage cabinet and lateral file lock independently; upper lock secures cabinet; lower locks secure file drawers. Locks are keyed alike. Door hinges rotate to 94 degrees. Unit height is designed to match desk, credenza, or return plus 35¼"H stack-on storage (= 64¾"). Ships fully assembled.

SPECIFYING EXAMPLE: HNL243665SLL.E.H.H

NOTES:

- Interchangeable core removable lock makes re-keying quick and easy.
- Finish of lock is determined by, and aligned with, the handle finish specified.
- Keyed alike cores must be ordered separately; specify model HF23B (Black) or HF23S (Satin) and specific key number required.

HOW TO SPECIFY

Select Model Number H N L 2 4 3 6 6 5 S L L .	Select Handle A Cylinder – Satin B Cylinder – Black C Canopy – Satin D Canopy – Black E Loop – Satin F Loop – Black E .	Select Chassis Color See page 29 H .	Select Door/Drawer Front Color See page 29 H
---	---	---	---



DESCRIPTION	MODEL	SHIP WEIGHT	CUBE	L1 LIST	L2 UPCHARGES	
					CHASSIS	FRONTS
Wardrobe/Storage Cabinet, Laminate Doors — 36"W 36"W x 24"D x 78 ¹ / ₈ "H 36"W x 24"D x 64 ³ / ₄ "H	HNL243679WL	303	40.8	\$2696	\$60	\$25
	HNL243665WL	284	40.8	\$2585	\$55	\$20

NOTES: Spacious design combines a cabinet with adjustable shelves and a generous personal wardrobe compartment with a coat rod and upper shelf. 64³/₄"H and 78¹/₈"H have five shelves (four adjustable) and six shelves (five adjustable), respectively; shelves adjust in 2¹/₂" increments. One lock secures both doors. Ships fully assembled.

SPECIFYING EXAMPLE: HNL243665WL.E.H.H

Wardrobe/Storage Cabinet, Laminate Door — 18"W 18"W x 24"D x 78 ¹ / ₈ "H, Hinged Right (shown) 18"W x 24"D x 78 ¹ / ₈ "H, Hinged Left 18"W x 24"D x 64 ³ / ₄ "H, Hinged Right 18"W x 24"D x 64 ³ / ₄ "H, Hinged Left	HNL241879WLR	205	24.8	\$1769	\$30	\$20
	HNL241879WLL	205	24.8	\$1769	\$30	\$20
	HNL241865WLR	157	21.6	\$1622	\$25	\$15
	HNL241865WLL	157	21.6	\$1622	\$25	\$15

NOTES: Design includes coat rod and shelves. 64³/₄"H and 78¹/₈"H have five shelves (four adjustable) and six shelves (five adjustable), respectively; shelves adjust in 2¹/₂" increments. Middle shelves can be removed to provide space for garments; coat rod can be removed for storage only applications. Lock to secure contents. Ships fully assembled.

SPECIFYING EXAMPLE: HNL241865WLR.E.H.H

Wardrobe/Bookcase, Laminate Door 36"W x 24"D x 78 ¹ / ₈ "H, Wardrobe Left, Bookcase Right 36"W x 24"D x 78 ¹ / ₈ "H, Wardrobe Right, Bookcase Left 36"W x 24"D x 64 ³ / ₄ "H, Wardrobe Left, Bookcase Right 36"W x 24"D x 64 ³ / ₄ "H, Wardrobe Right, Bookcase Left (shown)	HNL243679WLBR	302	47.4	\$2585	\$60	\$25
	HNL243679WRBL	302	47.4	\$2585	\$60	\$25
	HNL243665WLBR	230	40.8	\$2443	\$55	\$20
	HNL243665WRBL	230	40.8	\$2443	\$55	\$20

NOTES: Combination closed-door wardrobe closet and open shelf bookcase. 64³/₄"H and 78¹/₈"H bookcases have five and six fixed shelves, respectively. Locking wardrobe compartment includes a coat rod and one shelf; shelf is positioned above the coat rod. Bookcase can be accessed from front or side. Left (L) model is wardrobe on left, bookcase on right; Right (R) model is wardrobe on right, bookcase on left. Ships fully assembled.

SPECIFYING EXAMPLE: HNL243665WRBL.E.H.H

NOTES:

- Heights designed to match desk, credenza, or return plus 35¹/₄"H stack-on storage (= 64³/₄"H) or 48⁵/₈"H stack-on storage (= 78¹/₈"H).
- Finish of locks is determined by, and aligned with, the handle finish specified.
- Keyed alike cores must be ordered separately; specify model HF23B (Black) or HF23S (Satin) and specific key number required.

HOW TO SPECIFY

<p>Select Model Number</p> <p>H N L 2 4 3 6 5 W L .</p>	<p>Select Handle</p> <p>A Cylinder – Satin B Cylinder – Black C Canopy – Satin D Canopy – Black E Loop – Satin F Loop – Black</p> <p>E .</p>	<p>Select Chassis Color</p> <p>See page 29</p> <p>H .</p>	<p>Select Door Front Color</p> <p>See page 29</p> <p>H</p>
--	--	--	---

CONCINNITY™

Storage Towers

GSA SIN 33721

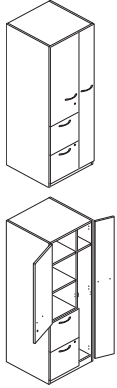

Icon Legend on page 19

**DESCRIPTION****Storage Towers, Laminate Doors — 24"W**24"W x 24"D x 78⁵/₈"H, Wardrobe Hinged Left, Cabinet Hinged Right**MODEL****HNL242479TLL****SHIP WEIGHT**

284

CUBE

32.4

L1 LIST**\$2504****L2 UPCHARGES****\$70****\$45**24"W x 24"D x 78⁵/₈"H, Wardrobe Hinged Right, Cabinet Hinged Left**HNL242479TLR**

284

32.4

\$2504**\$70****\$45**24"W x 24"D x 64³/₄"H, Wardrobe Hinged Left, Cabinet Hinged Right**HNL242465TLL**

241

27.6

\$2280**\$60****\$35**24"W x 24"D x 64³/₄"H, Wardrobe Hinged Right, Cabinet Hinged Left (shown)**HNL242465TLR**

241

27.6

\$2280**\$60****\$35**

NOTES: Versatile design includes a wardrobe closet, storage cabinet, and two file drawers, in one compact unit. Wardrobe contains a coat rod and upper shelf. 64³/₄"H and 78⁵/₈"H cabinets have three shelves (two adjustable) and four shelves (three adjustable), respectively; shelves adjust in 2¹/₂" increments. File drawers operate on ball-bearing suspensions with full extension. File drawer design includes integrated hangrails for side-to-side letter or legal filing; and front-to-back for letter filing. Upper lock secures wardrobe closet and storage cabinet; lower lock secures file drawers; the two locks are keyed alike. Left (L) model is wardrobe hinged left, cabinet hinged right; Right (R) model is wardrobe hinged right, cabinet hinged left. Ships fully assembled.

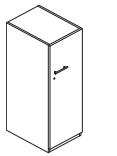
SPECIFYING EXAMPLE: HNL242465TLR.E.H.H

Hinged Right
HNL241850TLR shown

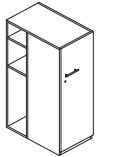

Hinged Right
HNL301850TLR shown

Storage Towers, Laminate Door — 50"H

18"W x 30"D x 50"H, Hinged Right

HNL301850TLR

135

19.8

\$1413**\$50****\$35**

18"W x 30"D x 50"H, Hinged Left

HNL301850TLL

135

19.8

\$1413**\$50****\$35**

18"W x 24"D x 50"H, Hinged Right

HNL241850TLR

121

15.9

\$1270**\$50****\$35**

18"W x 24"D x 50"H, Hinged Left

HNL241850TLL

121

15.9

\$1270**\$50****\$35**

NOTES: Low profile design is well-suited for open plan layouts. Can be used next to 29¹/₂"H to standing, 42"H worksurfaces. Cabinet includes coat hook on back of door, perfect for jackets, sweaters, and purses. Two adjustable interior shelves, plus bottom of unit; shelves adjust in 2¹/₂" increments. 30"D size has a slim side access storage space at rear of unit with two fixed interior shelves; the lower shelf is positioned to align with a 29¹/₂"H worksurface, the upper shelf with a 42"H worksurface. Hardware bag includes an extra coat hook which can be positioned on the side of the unit, below the worksurface; ideal for back packs. Left (L) model is door hinged left; Right (R) model is door hinged right. Worksurface tower bracket kit (model HSTB2W1) can be used to attach a worksurface directly to the tower. Bracket (1) eliminates the need for one end panel or O-leg support; (2) is not designed to be used as a support when a stack-on storage unit is placed over bracket. Ships fully assembled.

SPECIFYING EXAMPLE: HNL182450TLR.E.H.H**NOTES:**

- Equipped with interchangeable core removable locks.
- Finish of locks is determined by, and aligned with, the handle finish specified.
- Keyed alike cores must be ordered separately; specify model HF23B (Black) or HF23S (Satin) and specific key number required.

CABINET/WARDROBE/TOWER SOLUTIONS BY SIZE

	Low/50"H	Standard/64 ³ / ₄ "H	Executive/78 ⁵ / ₈ "H
Storage Cabinet with Doors		•	•
Storage/File Cabinet		•	
Storage Cabinet/Lateral File		•	
Wardrobe/Storage Cabinet		•	•
Wardrobe/Bookcase		•	•
Storage Tower		•	•
Storage Tower with Side Access on 30"D	•		
Bookcase with Coat Hook		•	

HOW TO SPECIFY

Select
Model Number

H N L 2 4 2 4 6 5 T L R .

Select
Handle

- A Cylinder – Satin
- B Cylinder – Black
- C Canopy – Satin
- D Canopy – Black
- E Loop – Satin
- F Loop – Black

E .

Select
Chassis Color

See page 29

H .

Select
Door Front Color

See page 29

E

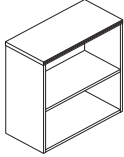
**DESCRIPTION****Bookcase with Adjustable Shelves**

30"W x 14¼"D x 78⅞"H, 6-Shelf
 30"W x 14¼"D x 65"H, 5-Shelf
 30"W x 14¼"D x 52¾"H, 4-Shelf
 30"W x 14¼"D x 42"H, 3-Shelf
 30"W x 14¼"D x 29½"H, 2-Shelf

MODEL	SHIP WEIGHT	CUBE	L1		L2 UPCHARGES	
			LIST	TOP	CHASSIS	
HNL1530BK6	170	25.7	\$967	\$30	\$35	
HNL1530BK5	143	21.1	\$857	\$25	\$30	
HNL1530BK4	118	17.4	\$743	\$20	\$25	
HNL1530BK3	95	14.1	\$653	\$15	\$20	
HNL1530BK2	69	10.2	\$574	\$15	\$15	

NOTES: Profiled top edge; choose from edge detail options. Number of total and adjustable shelves:

Height	Shelves	Adjustable Shelves
29½"	2	1
42"	3	2
52¾"	4	3
65"	5	4
78⅞"	6	5

¾" thick shelves adjust in ¼" increments. Inside shelf dimensions on all units are 28½"W x 13¼"D. Ships fully assembled.

SPECIFYING EXAMPLE: HNL1530BK2.BH.H.H

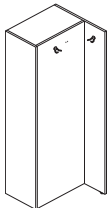
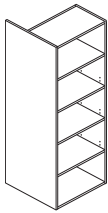

Back View

DESCRIPTION**Bookcase with Coat Hooks**

24"W x 24"D x 64¾"H, 5-Shelf, with Coat Hooks, Right (shown)
 24"W x 24"D x 64¾"H, 5-Shelf, with Coat Hooks, Left

MODEL	SHIP WEIGHT	CUBE	L1		L2	
			LIST PRICE	UPCHARGE		
HNL2424BK5CR	133	27.6	\$977		\$30	
HNL2424BK5CL	133	27.6	\$977		\$30	

NOTES: Inside shelf dimensions are 28½"W x 13¼"D. Two out of sight coat hooks for garments are secluded behind bookcase. One end panel measures 14¼"D, the other 24"D. "R" indicates coat hook access is on the right and the full 24"D end panel on the left; for use next to credenza or return with pedestal on right. "L" indicates coat hook access is on the left and the full 24"D end panel is on the right; for use next to credenza or return with pedestal on left. Unit height is designed to match desk, credenza, or return plus 35¼"H stack-on storage (= 64¾"). ¾" thick, non-profiled top edge. Not available in two-tone laminate color combinations. Ships fully assembled.

SPECIFYING EXAMPLE: HNL2424BK5CR.H

HOW TO SPECIFY

Select Model Number

H N L 1 5 3 0 B K 2 .

Select Edge Profile and Edge Color

See page 29

B H .

Select Top Color

See page 29

H .

Select Chassis Color

See page 29

H

Select Model Number

H N L 2 4 2 4 B K 5 C R .

Select Laminate

See page 29

H

CONCINNITY™ COMPONENTS

MODULAR COMPONENTS

- Smart, adaptable, reconfigurable assortment to maximize office layout flexibility and optimize floor space.
- Components for all popular office layouts.
- Selection allows user to choose their own workstation shape, size, and storage.
- Sizes for large and small spaces:
 - 36"D x 72"W or 84"W
 - 30"D — six sizes up to 84"W
 - 24"D — in 6" increments, from 30"W to 96"W
- Worksurfaces supported by post legs with casters provide added layout flexibility.
- Mobile desks quickly convert an office into a small conference space; desks roll easily and can be repositioned in seconds.
- Grommet options provide cord management from the top, side, and back in appropriate models.
- Broad menu of under-surface storage to enable user to specify the solution that best meets their individual needs.
 - Non-handed units can be configured to meet individual tastes and reconfigured when preferences or floor space requirements change.
 - Applications include:
 - The ability to “build” contiguous customized/personalized storage behind the desk that looks like custom architectural millwork, but at a fraction of the price. Allows for multiple storage pedestals to be configured under a single top with clean lines and no gaps.
 - Choosing the storage solution to go under desks, credenzas, and returns.

WORKSURFACES

- Available in a variety of shapes and sizes.
- Scratch-, stain-, and spill-resistant laminate over durable 1 $\frac{1}{8}$ " solid core high performance particleboard; resists warping.
- An external support channel, for attachment under worksurfaces, is required for all unsupported spans — a distance in which there is not a vertical support (point of contact) between the underside of the worksurface and the floor — greater than 54"W.
- For tri-oval and beaded edge options on tops with horizontal grain, there is a shaped profile on the user and approach sides, and a flat edge on the ends.
- For tri-oval and beaded edge options on tops with vertical grain, there is a shaped profile on the user side and a flat edge on the approach side and the ends.
- Grommets are an option and require specification. If grommets are selected, grommets come in a pre-determined location.

- Must be specified with support components; for pedestal, end panel, column, and leg options, see “Components — Supports” listings.

SUPPORTS

- For use with rectangle, bow, bullet, and extended corner worksurfaces.
- Available in 28 $\frac{1}{2}$ " and 41"H.
- Adjustable hex glides allow floor-standing units to be easily leveled, without lifting, to compensate for uneven floors; glides have 1 $\frac{1}{4}$ " adjustable range on most components; 2" on O-legs.
- Bottom of laminate end panels are edgebanded for added strength and to seal out moisture.

FOR 29 $\frac{1}{2}$ "H WORKSURFACES

- Specify from a broad assortment of solutions, including —
 - Modular Pedestals
 - Laminate end panels (must be used in conjunction with a laminate modesty panel)
 - Laminate L-shaped end panels
 - Laminate T-shaped end panels
 - Metal O-legs — for use with worksurfaces up to 78"W (when using an 84" or wider worksurface, cannot use two O-legs; must use at least one 1 $\frac{3}{4}$ " or wider pedestal for the other support).
 - 4 $\frac{1}{2}$ " diameter metal column
 - 2" square metal post leg

FOR 42"H WORKSURFACES

- 42", fixed standing-height workstations give users the option of changing postures from sitting to standing throughout the day to help achieve their wellness goals.
- Specify supports from —
 - Modular Pedestals
 - Laminate end panels (must be used in conjunction with a laminate modesty panel)
 - Laminate L-shaped end panels
 - Metal O-legs
- When combined with a stool-height task chair, provides users the benefit of alternating their work between a seated or standing position.
- An external support channel, for attachment under worksurfaces, is required for all unsupported spans greater than 54"W.

- Worksurface End Support (panel, leg, column, base, pedestal) requirements by product type are as follows —
 - Desk, peninsula, or credenza — qty. 2
 - Return — qty. 1
 - Island extension — qty. 1

COORDINATE™ HEIGHT ADJUSTABLE BASE

- Multiple base options available.
- Height adjustable bases deliver a healthier style of working by allowing a seamless transition between sitting and standing throughout the day. For open, private, or training spaces.
- Frame rises from 21⁵/₈" to 47³/₄".
- Telescoping base design.
- Accommodates rectangle worksurface sizes 24" to 30"D and 42" to 72"W.
- Standard-height adjustable control included with base. Memory control allows preset worksurface heights for consistency. See page 594 for additional control options.
- Shipped complete with a pre-assembled electric motor.

CONCINNITY™

Components — Worksurfaces

GSA SIN 33721



Icon Legend on page 19

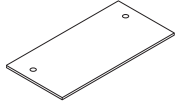

DESCRIPTION	MODEL	SHIP WEIGHT	CUBE	L1 LIST PRICE	L2 UPCHARGE
Rectangle Worksurface with Horizontal Grain					
84"W x 36"D	HNLRC3684	105	7.7	\$653	\$30
72"W x 36"D (shown)	HNLRC3672	90	6.7	\$546	\$30
84"W x 30"D	HNLRC3084	88	6.5	\$528	\$25
78"W x 30"D	HNLRC3078	81	6.1	\$478	\$25
72"W x 30"D	HNLRC3072	75	5.6	\$438	\$20
66"W x 30"D	HNLRC3066	69	5.2	\$403	\$20
60"W x 30"D	HNLRC3060	62	4.7	\$376	\$20
48"W x 30"D	HNLRC3048	50	3.9	\$307	\$15
96"W x 24"D	HNLRC2496	80	5.8	\$544	\$30
90"W x 24"D	HNLRC2490	75	5.5	\$533	\$30
84"W x 24"D	HNLRC2484	70	5.3	\$503	\$25
78"W x 24"D	HNLRC2478	65	4.9	\$450	\$20
72"W x 24"D	HNLRC2472	60	4.6	\$374	\$20
66"W x 24"D	HNLRC2466	55	4.2	\$361	\$20
60"W x 24"D	HNLRC2460	50	3.9	\$333	\$20
54"W x 24"D	HNLRC2454	45	3.5	\$305	\$20
48"W x 24"D	HNLRC2448	40	3.1	\$280	\$15
42"W x 24"D	HNLRC2442	35	2.8	\$262	\$15
36"W x 24"D Rectangle Worksurface/Pedestal Top	HNLRC2436	30	2.4	\$235	\$15
30"W x 24"D Rectangle Worksurface/Pedestal Top	HNLRC2430	25	2.1	\$235	\$15

NOTES: See chart on page 36 for cord management options.

- When grommets are specified for 30"D and 36"D rectangle worksurfaces, pre-drilled holes will not be included for a 4½" diameter support column.

NOTES:

- Grain direction on all rectangle worksurfaces runs horizontal (side-to-side) except as follows: 30"W - 36"W - 42"W - 48"W - 54"W - 60"W x 24"D tops can be specified with horizontal (side-to-side) or vertical (front-to-back) grain.
- 42"W and 48"W x 20"D tops are available with vertical (front-to-back) grain only.
- 48" - 72"W x 24" - 30"D worksurfaces are compatible for use with height adjustable electric base model HHAB3S2L.
- For standing-height requirements, use worksurface with 41"H O-leg, end panel, L-shaped end panel, or pedestal supports.
- For mobile desks and tables, use post leg with casters.
- For paper organizers, see page 110.
- Attachment of above privacy screen models requires a minimum 1" clear space/overhang on the underside of worksurface.
- Worksurfaces used with Coordinate™ Height Adjustable Bases should have 1" perimeter gap on each side to provide clearance between other furniture. Failure to do so risks injury or product damage (not covered by warranty).
- When using end panels or O-legs with 84", 90", or 96"W worksurfaces, interior weight-bearing support components are required to minimize worksurface deflection.
- Attachment of above/below privacy screen models requires a minimum 2" clear space/overhang on the underside of the worksurface.
- Steel external support channel can be attached to the underside of worksurfaces that are subjected to heavier loads. Channel is recommended to provide extra support on unsupported spans of 54"W or greater or per user preference. Ordered separately from worksurface.
- If using a 54"W or 60"W floating modesty panel, it is not necessary to specify an external support channel.
- When using an external support channel under the worksurface, the depth clearance for center drawers and keyboard platforms decreases by 8".
- See "External Channel (Recommended Use)" chart on page 85.

HOW TO SPECIFY

Select Model Number See page 29 H N L R C 3 6 8 4	Select Edge Profile and Edge Color See page 29 B H	Select Worksurface Grommet Finish P Black T1 Platinum X No Grommet P	Select Worksurface Color See page 29 H
---	--	--	--



CONCINNITY™

Components — Worksurfaces

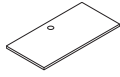

DESCRIPTION	MODEL	SHIP WEIGHT	CUBE	L1 LIST PRICE	L2 UPCHARGE
Rectangle Worksurface with Vertical Grain					
60"W x 24"D	HNLRC2460V	50	3.9	\$333	\$20
54"W x 24"D	HNLRC2454V	45	3.5	\$305	\$20
48"W x 24"D (shown)	HNLRC2448V	40	3.1	\$280	\$15
42"W x 24"D	HNLRC2442V	35	2.8	\$262	\$15
36"W x 24"D Rectangle Worksurface/Pedestal Top	HNLRC2436V	30	2.4	\$235	\$15
30"W x 24"D Rectangle Worksurface/Pedestal Top	HNLRC2430V	25	2.1	\$235	\$15
48"W x 20"D	HNLRC2048V	33	2.7	\$263	\$10
42"W x 20"D	HNLRC2042V	29	2.3	\$242	\$10

NOTES: Can be used in a host of applications, including as a desk, credenza, return, bridge, stationary or mobile table surface, in U- or L-shaped configurations, as part of a work wall layout with an island extension, or with the height adjustable electric base. The conference overhang dimension on the approach side of worksurfaces varies depending on the supports and modesty panels specified. Top can be positioned with a cantilevered conference overhang on one end when used with select worksurface supports, including an O-leg or 9½"W modular pedestal. For return applications in which there is an unsupported span wider than 54", such as a 72"W x 24"D worksurface supported by a 15¾"W modular pedestal (= 56¼") or a 60"W x 24"D worksurface supported by a 1½" thick end panel (= 58¾"), use internal support panel model HNL11SUPP. For bridges wider than 54", use internal support panel HNL11SUPP. When using a 30"W, 36"W, 42"W, or 48"W rectangle worksurface as a bridge, no support legs are needed. When specifying a 84"W, 90"W, or 96"W worksurface, cannot use two O-legs for the supports. In these applications, the maximum number of supports that can be an O-leg is one; must choose from a 15¾" or wider modular pedestal for use as the additional support component. For applications requiring connection to an adjoining worksurface, two flat brackets are included with 24"D and 20"D worksurfaces that are ≤48"W; one flat bracket is included with 24"D worksurfaces that are ≥54"W. Underside of worksurface includes pilot mounting holes for O-leg, 1½" thick laminate end panel, pedestals, and flat brackets. See chart on page 36 for cord management options.

ⓘ When grommets are specified for 30"D and 36"D rectangle worksurfaces, pre-drilled holes will not be included for attachment of a 4½" diameter support column.

NOTES:

- Grain direction on all rectangle worksurfaces runs horizontal (side-to-side) except as follows: 30"W - 36"W - 42"W - 48"W - 54"W - 60"W x 24"D tops can be specified with horizontal (side-to-side) or vertical (front-to-back) grain.
 - 42"W and 48"W x 20"D tops are available with vertical (front-to-back) grain only.
 - 48" - 72"W x 24" - 30"D worksurfaces are compatible for use with height adjustable electric base model HHAB3S2L.
 - For standing-height requirements, use worksurface with 41"H O-leg, end panel, L-shaped end panel, or pedestal supports.
 - For mobile desks and tables, use post leg with casters.
 - For paper organizers, see page 110.
- ⓘ Attachment of above privacy screen models requires a minimum 1" clear space/overhang on the underside of worksurface.
- ⓘ Worksurfaces used with Coordinate™ Height Adjustable Bases should have 1" perimeter gap on each side to provide clearance between other furniture. Failure to do so risks injury or product damage (not covered by warranty).
- ⓘ Attachment of above/below privacy screen models requires a minimum 2" clear space/overhang on the underside of the worksurface.
- ⓘ Steel external support channel can be attached to the underside of worksurfaces that are subjected to heavier loads. Channel is recommended to provide extra support on unsupported spans of 54"W or greater or per user preference. Ordered separately from worksurface.
- ⓘ If using a 54"W or 60"W floating modesty panel, it is not necessary to specify an external support channel.
- ⓘ When using an external support channel under the worksurface, the depth clearance for center drawers and keyboard platforms decreases by 8".
- ⓘ See "External Channel (Recommended Use)" chart on page 85.

HOW TO SPECIFY

Select Model Number H N L R C 2 4 6 0 V	Select Edge Profile and Edge Color See page 29 B H	Select Worksurface Grommet Finish P Black T1 Platinum X No Grommet P	Select Worksurface Color See page 29 H
---	---	---	---

CONCINNITY™

Components — Worksurfaces

GSA SIN 33721

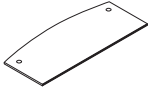
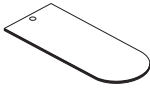

Icon Legend on page 19

	DESCRIPTION	MODEL	SHIP WEIGHT	CUBE	L1 LIST PRICE	L2 UPCHARGE
	Bow Worksurface					
	84"W x 36"D	HNLBW3684	94	7.7	\$697	\$30
	72"W x 36"D	HNLBW3672	80	6.7	\$629	\$30
	NOTES: 84"W size is ideal for executive layouts or for user's who require additional worksurface space. 72"W top can be combined with different pedestal support options to allow users to personalize their storage needs. Underside of worksurface includes pilot mounting holes for 1½" and L-shaped laminate end panels, and 29½"D pedestals. Grain direction runs horizontal (side-to-side). See chart on page 36 for cord management options.					
	Bullet Worksurface					
	84"W x 30"D	HNLBU3084	84	6.3	\$615	\$25
	78"W x 30"D	HNLBU3078	78	6.3	\$585	\$20
	72"W x 30"D	HNLBU3072	72	5.5	\$508	\$20
	66"W x 30"D	HNLBU3066	66	5.5	\$485	\$20
	60"W x 30"D	HNLBU3060	60	4.7	\$451	\$20
48"W x 30"D	HNLBU3048	54	3.7	\$395	\$15	
	NOTES: Applications include U- or L-shaped peninsula configurations and island extensions. Underside of worksurface includes pilot mounting holes for O-leg, T-shaped end panel, 29½"D pedestals, 4½" diameter support column, and 2" square post leg. One flat bracket is packaged with each worksurface for applications requiring connection to an adjoining worksurface. Grain direction runs horizontal (side-to-side). Can be used in combination with a 15¾"W or 9½"W x 29½"D x 28¼"H modular pedestal to create a freestanding desk. See chart on page 36 for cord management options.					

NOTES:

- ❗ When specifying an 84"W size, cannot use two O-legs; must use another type of support component such as a pedestal.
- ❗ Steel external support channel can be attached to the underside of worksurfaces that are subjected to heavier loads. Channel is recommended to provide extra support on unsupported spans of 54"W or greater or per user preference. Ordered separately from worksurface.
- ❗ If using a 54"W or 60"W floating modesty panel, it is not necessary to specify an external support channel.
- ❗ When using an external support channel under the worksurface, the depth clearance for center drawers and keyboard platforms decreases by 8".
- ❗ See "External Channel (Recommended Use)" chart on page 85.

HOW TO SPECIFY

Select Model Number H N L B W 3 6 8 4 .	Select Edge Profile and Edge Color See page 29 B H .	Select Worksurface Grommet Finish P Black T1 Platinum X No Grommet P .	Select Worksurface Color See page 29 H
---	---	---	---



CONCINNITY™

Components — Worksurfaces

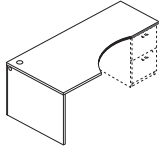

Right-hand model
HNLEC367224R shown

DESCRIPTION	MODEL	SHIP WEIGHT	CUBE	L1 LIST	L2 UPCHARGES	
					WORKSURFACE	END PANEL
Extended Corner Worksurface						
72"W x 48"D, Right	HNLEC487224R	130	8.9	\$1061	\$50	\$50
72"W x 48"D, Left	HNLEC487224L	130	8.9	\$1061	\$50	\$50
72"W x 36"D, Right	HNLEC367224R	106	6.6	\$877	\$45	\$45
72"W x 36"D, Left	HNLEC367224L	106	6.6	\$877	\$45	\$45

NOTES: For use in U- or L-shaped layouts. Includes top and long (47"D or 35"D) end panel components. Installation also requires modesty panel and either a 1½" thick end panel or 15¾" x 23⅜"D pedestal support for opposite end; both ordered separately. 72"W x 24/48"D or 48/24"D top is intended for use with 30/48"D or 48/30"D jetty peninsula to create a 2-piece "U" station with a curved cockpit on user's side. 72"W x 24/36"D or 36/24"D size is intended for use with 24"D returns or bridges. Underside of worksurface has pilot mounting holes for 1½" thick end panel and 15¾" x 23⅜"D modular pedestal. Edgebanding on the extended corner worksurface is profiled on the user's side and flat on the back (approach side) and ends. Grain direction runs horizontal (side-to-side).

❗ One flat bracket is packaged with each 48"D worksurface for applications requiring connection to a 48"D jetty peninsula. For 36"D extended corner worksurface, the flat bracket is shipped with the adjoining return or bridge. See chart on page 36 for cord management options. If grommet option is chosen, the worksurface component will match the color specified; the long end panel grommet color will be black.

NOTES:

- ❗ When specifying an 84"W size, cannot use two O-legs; must use another type of support component such as a pedestal.
- ❗ Steel external support channel can be attached to the underside of worksurfaces that are subjected to heavier loads. Channel is recommended to provide extra support on unsupported spans of 54"W or greater or per user preference. Ordered separately from worksurface.
- ❗ If using a 54"W or 60"W floating modesty panel, it is not necessary to specify an external support channel.
- ❗ When using an external support channel under the worksurface, the depth clearance for center drawers and keyboard platforms decreases by 8".
- ❗ See "External Channel (Recommended Use)" chart on page 85.

HOW TO SPECIFY

Select Model Number H N L E C 4 8 7 2 2 4 R .	Select Edge Profile and Edge Color See page 29 B H .	Select Worksurface Grommet Finish P Black T1 Platinum X No Grommet X .	Select Worksurface Color See page 29 H .	Select End Panel Color See page 29 H
---	---	---	---	---

CONCINNITY™ Components — Supports

GSA SIN 33721 EXCEPT AS NOTED



Icon Legend on page 19

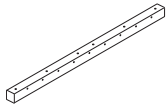

DESCRIPTION

External Support Channel
72"W for a 78" Worksurface
66"W for a 72" Worksurface
60"W for a 66" Worksurface
54"W for a 60" Worksurface
48"W for a 54" Worksurface

MODEL

HLSLZ5SC84
HLSLZ5SC78
HLSLZ5SC72
HLSLZ5SC66
HLSLZ5SC60

SHIP WEIGHT

12
7
7
7
6

CUBE

0.7
0.5
0.5
0.5
0.5

LIST PRICE

\$110
\$110
\$110
\$101
\$98

- ⓘ Available in Graphite paint only.
- ⓘ Attaches to underside of worksurface; required for unsupported spans greater than 54"W.
- ⓘ When specifying a 54"W or 60"W Floating Modesty Panel, it is not necessary to specify an external channel.

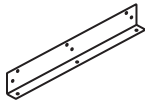

HVPWLBK24 shown

OPEN MARKET

Worksurface Wall Mount Bracket

For 30"
For 24"

HVPWLBK30
HVPWLBK24

2
2

0.3
0.3

\$91
\$83

NOTES: Can be used in place of an end panel to support a worksurface. Cannot be used as a support when placing a stack-on storage unit on worksurface over bracket; must have two full-sized floor supports when using stack-on storage. Finish option not required.

SPECIFYING EXAMPLE: HVPWLBK30



DESCRIPTION

Worksurface to Tower Bracket Kit
18½" long bracket for attaching 24"D worksurface directly to storage tower, wardrobe/bookcase, wardrobe/storage cabinet, storage cabinet/lateral file, storage cabinet, or lateral file.

MODEL

HSTB2W1

SHIP WEIGHT

4

CUBE

0.6

LIST PRICE BY PAINT GRADE

P1

\$79

P2

\$92

P3

\$94

NOTES: Can be used in place of end panel or O-leg to support worksurfaces.

- ⓘ Bracket not designed for use as a support if placing Stack-on Storage on worksurface over/above bracket. Two full-sized supports required when using Stack-on Storage.

NOTES:

- Use the worksurface to tower bracket kit to attach worksurfaces to Storage Tower models.
- ⓘ Depending on your support combination, an external channel may be required for extra support on unsupported spans greater than 54"W.

HOW TO SPECIFY

Select Model Number

H L S L Z 5 S C 8 4

HNL Support Options — External Channel (model HLSLZ5SCxx) - Recommended Use

	Support Combination		Worksurface Width											
	Support 1	Support 2	30"	36"	42"	48"	54"	60"	66"	72"	78"	84"	90"	96"
O-LEG ON ONE END	O-Leg	O-Leg	NR	NR	NR	NR	60	66	72	78	84	NA	NA	NA
	O-Leg	9½"W Ped	NR	NR	NR	NR	NR	60	66	72	78	84	NA	NA
	O-Leg	End Bookcase	NA	NR	NR	NR	NR	NR	60	66	72	78	84	NA
	O-Leg	L End Panel	NR	NR	NR	NR	NR	60	66	72	78	84	NA	NA
	O-Leg	15¾"W Ped	NA	NR	NR	NR	NR	NR	NR	60	66	72	78	NA
	O-Leg	18"W Ped	NA	NA	NR	NR	NR	NR	NR	60	66	72	78	84
	O-Leg	30"W Ped	NA	NA	NA	NA	NR	NR	NR	NR	NR	60	66	72
	O-Leg	36"W Ped	NA	NA	NA	NA	NA	NR	NR	NR	NR	NR	60	66
	NARROW PED	9½"W Ped	9½"W Ped	NA	NA	NR	NR	NR	NR	NR	60	66	72	78
9½"W Ped		End Bookcase	NA	NA	NR	NR	NR	NR	NR	60	66	72	78	84
9½"W Ped		L End Panel	NA	NR	NR	NR	NR	NR	60	66	72	78	84	NA
9½"W Ped		15¾"W Ped	NA	NA	NA	NR	NR	NR	NR	NR	60	66	72	78
9½"W Ped		18"W Ped	NA	NA	NA	NR	NR	NR	NR	NR	60	66	72	78
9½"W Ped		30"W Ped	NA	NA	NA	NA	NA	NR	NR	NR	NR	NR	60	66
9½"W Ped		36"W Ped	NA	NA	NA	NA	NA	NA	NR	NR	NR	NR	NR	60
END BOOKCASE PED	End Bookcase	End Bookcase	NA	NA	NR	NR	NR	NR	NR	NR	60	66	72	78
	End Bookcase	L End Panel	NA	NA	NR	NR	NR	NR	NR	60	66	72	78	84
	End Bookcase	15¾"W Ped	NA	NA	NA	NR	NR	NR	NR	NR	60	66	72	78
	End Bookcase	18"W Ped	NA	NA	NA	NR	NR	NR	NR	NR	60	66	72	78
	End Bookcase	30"W Ped	NA	NA	NA	NA	NA	NR	NR	NR	NR	NR	60	66
	End Bookcase	36"W Ped	NA	NA	NA	NA	NA	NA	NR	NR	NR	NR	NR	60
L END PANEL	L End Panel	L End Panel	NA	NR	NR	NR	NR	NR	60	66	72	78	84	NA
	L End Panel	15¾"W Ped	NA	NA	NR	NR	NR	NR	NR	NR	60	66	72	78
	L End Panel	18"W Ped	NA	NA	NA	NR	NR	NR	NR	NR	60	66	72	78
	L End Panel	30"W Ped	NA	NA	NA	NA	NA	NR	NR	NR	NR	NR	60	66
	L End Panel	36"W Ped	NA	NA	NA	NA	NA	NA	NR	NR	NR	NR	NR	60
TWO PEDS	15¾"W Ped	15¾"W Ped	NA	NA	NA	NA	NR	NR	NR	NR	NR	60	66	72
	15¾"W Ped	18"W Ped	NA	NA	NA	NA	NR	NR	NR	NR	NR	60	66	72
	15¾"W Ped	30"W Ped	NA	NA	NA	NA	NA	NR	NR	NR	NR	NR	NR	60
	15¾"W Ped	36"W Ped	NA	NA	NA	NA	NA	NA	NR	NR	NR	NR	NR	60
	18"W Ped	18"W Ped	NA	NR	NA	NA	NR	NR	NR	NR	NR	NR	60	66
	18"W Ped	30"W Ped	NA	NA	NA	NR	NA	NA	NR	NR	NR	NR	NR	60
	18"W Ped	36"W Ped	NA	NA	NA	NA	NA	NA	NR	NR	NR	NR	NR	60
	30"W Ped	30"W Ped	NA	NA	NA	NA	NA	NR	NR	NR	NR	NR	NR	60
	30"W Ped	36"W Ped	NA	NA	NA	NA	NA	NA	NR	NR	NR	NR	NR	60
	36"W Ped	36"W Ped	NA	NA	NA	NA	NA	NA	NR	NR	NR	NR	NR	60
RETURN CONFIGURATION	None	O-Leg	NR	NR	NR	NR	60	66	72	78	84	NA	NA	NA
	None	9½"W Ped	NR	NR	NR	NR	NR	60	66	72	78	84	NA	NA
	None	End Bookcase	NA	NR	NR	NR	NR	NR	60	66	72	78	84	NA
	None	L End Panel	NR	NR	NR	NR	NR	60	66	72	78	84	NA	NA
	None	15¾"W Ped	NA	NR	NR	NR	NR	NR	NR	60	66	72	78	NA
	None	18"W Ped	NA	NA	NR	NR	NR	NR	NR	60	66	72	78	84
	None	30"W Ped	NA	NA	NA	NA	NR	NR	NR	NR	NR	60	66	72
	None	36"W Ped	NA	NA	NA	NA	NA	NR	NR	NR	NR	NR	60	66

NA = Stiffener not applicable due to invalid worksurface width and support combination

NR = Applicable worksurface width and support combination, but stiffener not required

! The chart reference is to be used to complete the model number. It is not the actual length dimension of the external support channel.

CONCINNITY™ Components — Modesty/Back Panels

GSA SIN 33721



Icon Legend on page 19

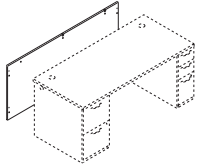

DESCRIPTION

Modesty/Back Panels — Full-Length

- 96"W x 27¹/₈"H
- 90"W x 27¹/₈"H
- 84"W x 27¹/₈"H
- 78"W x 27¹/₈"H
- 72"W x 27¹/₈"H
- 66"W x 27¹/₈"H
- 60"W x 27¹/₈"H
- 54"W x 27¹/₈"H
- 48"W x 27¹/₈"H
- 42"W x 27¹/₈"H

MODEL

- HNLMP9628**
- HNLMP9028**
- HNLMP8428**
- HNLMP7828**
- HNLMP7228**
- HNLMP6628**
- HNLMP6028**
- HNLMP5428**
- HNLMP4828**
- HNLMP4228**

SHIP WEIGHT

CUBE

L1 LIST PRICE

L2 UPCHARGE

- 36"W x 27¹/₈"H Modesty/Pedestal Back Panel
- 30"W x 27¹/₈"H Modesty/Pedestal Back Panel

- HNLMP3628**
- HNLMP3028**

- 22
- 18

- 2.8
- 2.4

- \$193**
- \$179**

- \$12**
- \$12**

Modesty/Back Panels — Short

- 96"W x 10"H
- 90"W x 10"H
- 84"W x 10"H
- 78"W x 10"H
- 72"W x 10"H
- 66"W x 10"H
- 60"W x 10"H
- 54"W x 10"H
- 48"W x 10"H
- 42"W x 10"H
- 36"W x 10"H
- 30"W x 10"H

- HNLMP9610**
- HNLMP9010**
- HNLMP8410**
- HNLMP7810**
- HNLMP7210**
- HNLMP6610**
- HNLMP6010**
- HNLMP5410**
- HNLMP4810**
- HNLMP4210**
- HNLMP3610**
- HNLMP3010**

- 22
- 21
- 20
- 19
- 18
- 17
- 16
- 15
- 14
- 13
- 12
- 11

- 3.0
- 2.8
- 2.8
- 2.3
- 2.1
- 1.9
- 1.8
- 1.6
- 1.4
- 1.3
- 1.1
- 0.9

- \$439**
- \$428**
- \$355**
- \$314**
- \$292**
- \$274**
- \$248**
- \$240**
- \$227**
- \$208**
- \$193**
- \$179**

- \$15**
- \$15**
- \$15**
- \$12**
- \$12**
- \$12**
- \$12**
- \$12**
- \$10**
- \$10**
- \$10**
- \$10**

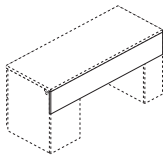

Back View

NOTES: For use with modular worksurface and support components. Component is 3/4" thick. Full-to-floor sizes can be specified with or without grommet; see chart on page 36 for cord management options. For standing-height applications, a worksurface supported by 1 1/8" thick x 41"H laminate end panel(s) and/or 41"H support pedestal(s), the recommended modesty panel length extends 27 1/8" below the underside of the top, leaving 13" of wall access; 9 1/2" and 15 3/4" W x 13"H backs are available to enclose the balance of the pedestal back. Worksurfaces supported by a 1 1/8" thick x 41"H laminate end panel and 41"H support pedestal, or by two 41"H support pedestals, can be used with a 10" modesty panel to increase the amount of wall access, however in this application the pedestal(s) should be positioned against a wall, as there is not a 30 7/8"H panel to cover the back of the pedestal that is exposed below the modesty panel. The 10"H modesty panel is not recommended for use in a standing-height shell, where both supports are 41"H laminate end panels; for this solution use the 27 1/8"H modesty panel. For standing-height applications with the worksurface supported by 41"H O-legs or L-shaped end panels, use the appropriate floating modesty panel size.

NOTES:

- Provide approach-side kneespace privacy for user seated at desks, credenzas, returns, and bridges.
- Full-width laminate panel can be specified in 6" increments from 30"-96"W, and in full-length (27 1/8"H) or short (10"H).
- Formal, full-length, 27 1/8"H models extend from the underside of the worksurface to the floor.
- 10"H sizes allow quick and easy access to wall power outlets.
- 30"W and 36"W x 27 1/8"H are sized to serve as a modesty panel, or pedestal back for respective 30"W and 36"W support storage pedestal models.
- ! The full-width panel designs are specifically for use when the worksurface supports are two 1 1/8" thick end panels, two support storage pedestals, or one 1 1/8" thick end panel and one support storage pedestal; not for use with O-legs or L-shaped end panels.

HOW TO SPECIFY

<p>Select Model Number</p> <p>H N L M P 7 2 2 8</p>	<p>Select Grommet</p> <p>P Black X No Grommet</p> <p>X</p>	<p>Select Laminate Color</p> <p>See page 29</p> <p>H</p>
--	---	---

<p>Select Model Number</p> <p>H N L M P 7 2 1 0</p>	<p>Select Laminate Color</p> <p>See page 29</p> <p>H</p>	
--	---	--



CONCINNITY™

Components — Modesty/Back Panels

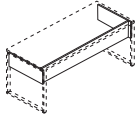

Not available in two-tone laminate

DESCRIPTION	MODEL	SHIP WEIGHT	CUBE	L1 LIST PRICE	L2 UPCHARGE
Modesty Panels for Desks with O-Legs					
68 $\frac{3}{8}$ "W x $\frac{3}{4}$ "D x 10"H — For 72" x 30" Desks	HLAMMP7230	26	2.1	\$289	\$15
56 $\frac{3}{8}$ "W x $\frac{3}{4}$ "D x 10"H — For 60" x 30" Desks	HLAMMP6030	23	1.8	\$264	\$15

NOTES: For use with 60"W or 72"W worksurfaces supported by O-legs. Comprised of three panels: one approach side and one for each end. Length below bottom of worksurface is 10". Steel external support channel (ordered separately) is recommended for unsupported spans greater than 54"W (i.e.: a distance in which there is not a vertical support between the underside of the worksurface and floor). Grain direction is vertical on approach and side panels for 56 $\frac{3}{8}$ "W (all laminate colors) and 68 $\frac{3}{8}$ "W (L1 laminate except Florence Walnut and Kingswood Walnut). Vertical on 27 $\frac{5}{8}$ " end panels (all laminate colors). Horizontal on all panels for L2 laminates as well as Florence Walnut and Kingswood Walnut.

Specify: Model.Laminate

SPECIFYING EXAMPLE: HLAMMP7230.N

! \$15 upcharge for L2 laminates. See pages 236-237 for laminate options.

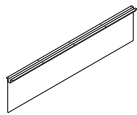

DESCRIPTION	MODEL	SHIP WEIGHT	CUBE	L1 LIST PRICE	L2 UPCHARGE
Laminate Floating Modesty Panel					
60"W x 14"H	HLSL6014L	20	1.1	\$253	\$12
54"W x 14"H	HLSL5414L	18	1.1	\$235	\$12
48"W x 14"H	HLSL4814L	16	1.1	\$215	\$12
42"W x 14"H	HLSL4214L	14	0.8	\$195	\$10
36"W x 14"H	HLSL3614L	12	0.8	\$183	\$10
30"W x 14"H	HLSL3014L	10	0.8	\$173	\$10

NOTES: The attachment bracket and modesty panel are packaged separately.

Specify: Model.Laminate.Paint

SPECIFYING EXAMPLE: HLSL3014L.N.P (Black is the only paint option for this model)

! When specifying the 54"W or 60"W Laminate Floating Modesty Panel, it is not necessary to specify an external support channel.

! 30"W and 36"W screens attach with L-brackets, not the external channel.

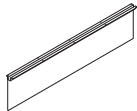

DESCRIPTION	MODEL	SHIP WEIGHT	CUBE	L1 LIST PRICE	L2 UPCHARGE
Mixed Material Floating Modesty Panel					
60"W x 14"H	HLSL6014MM ☺	13	3.3	\$1134	N/A
54"W x 14"H	HLSL5414MM ☺	13	3.3	\$992	N/A
48"W x 14"H	HLSL4814MM ☺	11	2.6	\$914	N/A
42"W x 14"H	HLSL4214MM ☺	9	2.3	\$826	N/A
36"W x 14"H	HLSL3614MM	8	2.0	\$739	N/A
30"W x 14"H	HLSL3014MM	8	2.0	\$689	N/A

NOTES: The attachment bracket and modesty panel are packaged separately.

Specify: Model.Mixed Material.Paint

SPECIFYING EXAMPLE: HLSL3014MM.FT01.P (Frosted Translucent mixed material and Black paint are the only options for this model)

! When specifying the 54"W or 60"W Mixed Material Floating Modesty Panel, it is not necessary to specify an external support channel.

NOTES:

- Floating panel options attach under worksurfaces and are available in laminate or mixed (frosted translucent) material. The modesty panel and attachment bracket are packaged separately.
- If using a 54"W or 60"W floating modesty panel, it is not necessary to specify an external support channel.
- When using a floating modesty panel under the worksurface, the depth clearance for center drawers and keyboard platforms decreases by 8".
- The full width/half-height and full-to-floor/full-height panels are filler options designed only for use on 60", 66", and 72"W x 29 $\frac{1}{2}$ "H, double, 15 $\frac{3}{4}$ "W, pedestal desks and credenzas that are specified/built with modular components.

HOW TO SPECIFY

Select Model Number HLSL3014MM	Select Mixed Material FT01 Frosted Translucent
--	--

CONCINNITY™

Components — Modesty/Back Panels

GSA SIN 33721

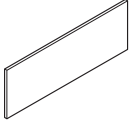
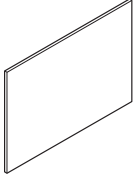

Icon Legend on page 19

	DESCRIPTION	MODEL	SHIP WEIGHT	CUBE	L1 LIST PRICE	L2 UPCHARGE
	Full Width/Half-Height Laminate Modesty Panel					
	40"W x 14"H, for use with 72" desks	HLSL4014LM	29	2.4	\$203	\$10
	34"W x 14"H, for use with 66" desks	HLSL3414LM	23	1.9	\$195	\$10
	28"W x 14"H, for use with 60" desks	HLSL2814LM	19	1.6	\$189	\$10
	NOTES: Filler piece that can only be used between the following supports: two 15¾"W modular pedestals, two 15¾"W L-shaped end panels, or one 15¾"W modular pedestal and one 15¾"W L-shaped end panel. Attachment brackets included.					
	Full-to-Floor/Full-Length Laminate Modesty Panel					
	40"W x 28½"H, for use with 72" desks	HLSL4028LM	44	3.6	\$312	\$12
	34"W x 28½"H, for use with 66" desks	HLSL3428LM	38	3.2	\$296	\$12
	28"W x 28½"H, for use with 60" desks	HLSL2828LM	33	2.7	\$252	\$12
	NOTES: Filler piece that can only be used between the following supports: two 15¾"W modular pedestals, two 15¾"W L-shaped end panels, or one 15¾"W modular pedestal and one 15¾"W L-shaped end panel. Attachment brackets included.					

NOTES:

- Floating panel options attach under worksurfaces and are available in laminate or mixed (frosted translucent) material. The modesty panel and attachment bracket are packaged separately.
- If using a 54"W or 60"W floating modesty panel, it is not necessary to specify an external support channel.
- When using a floating modesty panel under the worksurface, the depth clearance for center drawers and keyboard platforms decreases by 8".
- The full width/half-height and full-to-floor/full-height panels are filler options designed only for use on 60", 66", and 72"W x 29½"H, double, 15¾"W, pedestal desks and credenzas that are specified/built with modular components.

HOW TO SPECIFY

Select Model Number

Select Laminate Color

See page 29

HLSL2814LM.

N

CONCINNITY™ MODESTY/BACK PANELS

HNL Floating Modesty Panel — HSLx14L/MM — Selection Guide														
	Support Combination		Worksurface Width											
	Support 1	Support 2	30"	36"	42"	48"	54"	60"	66"	72"	78"	84"	90"	96"
O-LEG ON ONE END	O-Leg	O-Leg	NA	NA	36	42	48	54	60	60	60	NA	NA	NA
	O-Leg	9½"W Ped	NA	NA	NA	30	36	42	48	54	60	60	NA	NA
	O-Leg	End Bookcase	NA	NA	NA	30	36	42	48	54	60	60	60	NA
	O-Leg	L End Panel	NA	NA	NA	36	42	48	54	60	60	60	NA	NA
	O-Leg	15¾"W Ped	NA	NA	NA	NA	30	36	42	48	54	60	60	NA
	O-Leg	18"W Ped	NA	NA	NA	NA	30	36	42	48	54	60	60	60
	O-Leg	30"W Ped	NA	NA	NA	NA	NA	NA	30	36	42	48	54	60
	O-Leg	36"W Ped	NA	NA	NA	NA	NA	NA	NA	30	36	42	48	54
NARROW PED	9½"W Ped	9½"W Ped	NA	NA	NA	NA	30	36	42	48	54	60	60	60
	9½"W Ped	End Bookcase	NA	NA	NA	NA	30	36	42	48	54	60	60	60
	9½"W Ped	L End Panel	NA	NA	NA	NA	30	36	42	48	54	60	60	NA
	9½"W Ped	15¾"W Ped	NA	NA	NA	NA	NA	30	36	42	48	54	60	60
	9½"W Ped	18"W Ped	NA	NA	NA	NA	NA	30	36	42	48	54	60	60
	9½"W Ped	30"W Ped	NA	NA	NA	NA	NA	NA	NA	NA	30	36	48	48
	9½"W Ped	36"W Ped	NA	NA	NA	NA	NA	NA	NA	NA	30	36	42	48
END BOOKCASE PED	End Bookcase	End Bookcase	NA	NA	NA	NA	NA	30	36	42	48	54	60	60
	End Bookcase	L End Panel	NA	NA	NA	NA	30	36	36	48	54	60	60	60
	End Bookcase	15¾"W Ped	NA	NA	NA	NA	NA	30	36	42	48	54	60	60
	End Bookcase	18"W Ped	NA	NA	NA	NA	NA	NA	30	36	42	48	54	60
	End Bookcase	30"W Ped	NA	NA	NA	NA	NA	NA	NA	NA	30	36	42	48
	End Bookcase	36"W Ped	NA	NA	NA	NA	NA	NA	NA	NA	NA	30	36	42
L END PANEL	L End Panel	L End Panel	NA	NA	NA	NA	36	36	48	54	60	60	60	NA
	L End Panel	15¾"W Ped	NA	NA	NA	NA	NA	30	36	42	48	54	60	60
	L End Panel	18"W Ped	NA	NA	NA	NA	NA	30	36	42	48	54	60	60
	L End Panel	30"W Ped	NA	NA	NA	NA	NA	NA	NA	30	36	42	48	54
	L End Panel	36"W Ped	NA	NA	NA	NA	NA	NA	NA	NA	30	36	42	48
TWO PEDS	15¾"W Ped	15¾"W Ped	NA	NA	NA	NA	NA	NA	30	36	42	48	54	60
	15¾"W Ped	18"W Ped	NA	NA	NA	NA	NA	NA	30	36	36	48	54	60
	15¾"W Ped	30"W Ped	NA	NA	NA	NA	NA	NA	NA	NA	30	36	42	48
	15¾"W Ped	36"W Ped	NA	NA	NA	NA	NA	NA	NA	NA	30	36	42	48
	18"W Ped	18"W Ped	NA	NA	NA	NA	NA	NA	NA	30	36	42	48	54
	18"W Ped	30"W Ped	NA	NA	NA	NA	NA	NA	NA	NA	NA	30	36	42
	18"W Ped	36"W Ped	NA	NA	NA	NA	NA	NA	NA	NA	NA	NA	30	36
	30"W Ped	30"W Ped	NA	NA	NA	NA	NA	NA	NA	NA	NA	NA	NA	30
	30"W Ped	36"W Ped	NA	NA	NA	NA	NA	NA	NA	NA	NA	NA	NA	NA
	36"W Ped	36"W Ped	NA	NA	NA	NA	NA	NA	NA	NA	NA	NA	NA	NA
HT ADJ BASE	Height Adjustable Electric Base (model HHAB3S2L)		NA	NA	NA	42	48	54	60	60	NA	NA	NA	NA
PENINSULA	Support Column	T End Panel	NA	NA	NA	30	30	36	42	48	54	60	60	60
	Support Column	9½"W Ped	NA	NA	NA	NA	NA	30	36	42	48	54	60	60
	Support Column	15¾"W Ped	NA	NA	NA	NA	NA	NA	30	36	42	48	54	60
	Support Column	18"W Ped	NA	NA	NA	NA	NA	NA	30	36	42	48	54	60
	Support Column	30"W Ped	NA	NA	NA	NA	NA	NA	NA	NA	30	36	42	48
	Support Column	36"W Ped	NA	NA	NA	NA	NA	NA	NA	NA	NA	30	36	42
RETURN CONFIGURATION	None	O-Leg	NA	NA	36	42	48	54	60	60	60	NA	NA	NA
	None	9½"W Ped	NA	NA	NA	30	36	42	48	54	60	60	NA	NA
	None	End Bookcase	NA	NA	NA	30	36	42	48	54	60	60	60	NA
	None	L End Panel	NA	NA	36	36	42	48	54	60	60	60	NA	NA
	None	15¾"W Ped	NA	NA	NA	NA	30	36	42	48	54	60	60	NA
	None	18"W Ped	NA	NA	NA	NA	30	36	42	48	54	60	60	60
	None	30"W Ped	NA	NA	NA	NA	NA	NA	30	36	42	48	54	60
	None	36"W Ped	NA	NA	NA	NA	NA	NA	NA	30	36	42	48	60

NA = Floating Modesty Panel not applicable for use with worksurface width and support combination

CONCINNITY™ Components — Supports

GSA SIN 33721

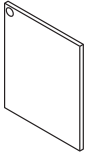
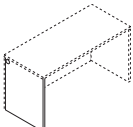
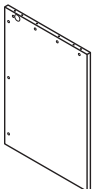

Icon Legend on page 19

	DESCRIPTION	MODEL	SHIP WEIGHT	CUBE	L1 LIST PRICE	L2 UPCHARGE
 HNLEP2428R shown	1 1/8" Laminate End Panels — For 29 1/2"H 1 1/8"W x 35"D x 28 1/2"H for 36"D, Right 1 1/8"W x 35"D x 28 1/2"H for 36"D, Left	HNLEP3628R HNLEP3628L	39 39	2.8 2.8	\$266 \$266	\$20 \$20
	1 1/8"W x 29 1/8"D x 28 1/2"H for 30"D, Right 1 1/8"W x 29 1/8"D x 28 1/2"H for 30"D, Left	HNLEP3028R HNLEP3028L	32 32	2.3 2.3	\$234 \$234	\$15 \$15
 HNLEP2428L shown	1 1/8"W x 23 1/8"D x 28 1/2"H for 24"D, Right 1 1/8"W x 23 1/8"D x 28 1/2"H for 24"D, Left	HNLEP2428R HNLEP2428L	22 22	1.9 1.9	\$208 \$208	\$10 \$10
	1 1/8" Laminate End Panels — For 42"H 1 1/8"W x 29 1/8"D x 41"H for 30"D, Right 1 1/8"W x 29 1/8"D x 41"H for 30"D, Left	HNLEP3041R HNLEP3041L	47 47	3.2 3.2	\$264 \$264	\$20 \$20
 HNLEP2441R shown	1 1/8"W x 23 1/8"D x 41"H for 24"D, Right 1 1/8"W x 23 1/8"D x 41"H for 24"D, Left	HNLEP2441R HNLEP2441L	37 37	2.6 2.6	\$248 \$248	\$15 \$15

NOTES: Supports the end of a component worksurface where there is no modular pedestal. 1 1/8" Laminate End Panels must be used with a full-length (27 7/8"H) or short (10"H) modesty/back panel; ordered separately, see page 86. The depth of an end panel is 3/4" less than the depth of the worksurface, to accommodate the modesty/back panel. Handed design (left and right models). Bottom of end panel is edgebanded for added strength and to seal out moisture. Applications include — For the non-pedestal end of single pedestal desks or credenzas utilizing modular storage components. For returns that do not have a modular storage pedestal to support the worksurface. For extended corner units that do not utilize a 15 3/4"W x 23 1/8"D modular storage pedestal to support the 24"D worksurface dimension. For building desk or credenza shells comprised of a worksurface top and modesty/back panel components, and left and right end panel. Available in a woodgrain or solid laminate color only. Can be specified with or without grommet; see chart on page 36 for cord management options. If grommet option is chosen, the color is black only.

NOTES:

! 1 1/8" Laminate End Panels must be used with a full-length (27 7/8"H) or short (10"H) modesty/back panel; ordered separately, see page 86.

HOW TO SPECIFY

<p>Select Model Number</p> <p>H N L E P 2 4 2 8 R .</p>	<p>Select Grommet</p> <p>P Black X No Grommet</p> <p>X .</p>	<p>Select Laminate Color</p> <p>See page 29</p> <p>H</p>
--	--	---



Kneespace Clearance End Panels

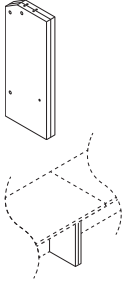

DESCRIPTION	MODEL	SHIP WEIGHT	CUBE	L1	L2
				LIST PRICE	UPCHARGE
Kneespace Clearance End Panels 1 1/8"W x 11 1/4"D x 41"H for 24"D, 2 pk	HNLEP1141	25	2.8	\$292	\$10
1 1/8"W x 11 1/4"D x 28 1/2"H for 24"D, 2 pk	HNLEP1128	25	2.0	\$238	\$10

NOTES: Creates additional kneespace for the user. Two 1 1/8"W x 11 1/4"D laminate end panels, one left, one right; sized to support two adjoining, contiguous 24"D worksurfaces. Can be specified with worksurfaces at time of installation or ordered as replacement for two side-by-side 1 1/8"W x 23"D end panels. Available in 28 1/2" and 41"H. Can be used to connect up to three credenzas in line (2 kits). Not designed for use with returns. Allows conversion of units currently in the field; European fasteners make installation quick and easy. Cord routing notch in top back of each panel. Includes two 1 1/8" thick panels; European fastening hardware; flat connector bracket; self-tapping wood screws for ganging credenza to adjacent worksurface; and adjustable leveling glides. Can be specified in a woodgrain or solid laminate color only; not in a two-tone combination.

SPECIFYING EXAMPLE: HNLEP1128.H

HOW TO SPECIFY

<p>Select Model Number</p> <p>HNLEP1128</p>	<p>Select Grommet</p> <p>P Black X No Grommet</p> <p>X</p>
--	---

CONCINNITY™ Components — Supports

GSA SIN 33721



Icon Legend on page 19

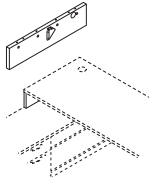

HNLLEP307L shown

DESCRIPTION	MODEL	SHIP WEIGHT	CUBE	L1 LIST PRICE	L2 UPCHARGE
Laminate End Panel — 7”H Support for Worksurfaces					
1½”W x 30”D x 7”H, Right	HNLLEP307R	7	0.7	\$136	\$10
1½”W x 30”D x 7”H, Left	HNLLEP307L	7	0.7	\$136	\$10
1½”W x 24”D x 7”H, Right	HNLLEP247R	6	0.7	\$136	\$10
1½”W x 24”D x 7”H, Left	HNLLEP247L	6	0.7	\$136	\$10

NOTES: Specifically for layered surface applications; used to support a 29½”H component worksurface over a 21½”H low credenza unit. 1½” thick. Handed design (left and right models). Includes cord routing notch. Bottom of end panel is edgebanded for added strength and to seal out moisture. Attaches to underside of worksurface via cam fasteners and L-bracket; attaches to top of low credenza with double-sided tape. Can be specified in a woodgrain or solid laminate color only. For 7”H metal O-leg support see page 94.

SPECIFYING EXAMPLE: HNLLEP307R.H

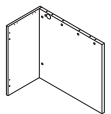

HNLLEP3028R shown

DESCRIPTION	MODEL	SHIP WEIGHT	CUBE	L1 LIST PRICE	L2 UPCHARGE
Laminate L-Shaped End Panels — For 29½”H					
15¾”W x 30”D x 28½”H, Right	HNLLEP3028R	38	4.3	\$376	\$15
15¾”W x 30”D x 28½”H, Left	HNLLEP3028L	38	4.3	\$376	\$15
15¾”W x 24”D x 28½”H, Right	HNLLEP2428R	32	2.8	\$339	\$15
15¾”W x 24”D x 28½”H, Left	HNLLEP2428L	32	2.8	\$339	\$15

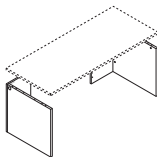

HNLLEP3028R and HNLLEP3028L shown

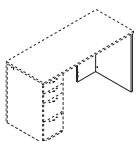
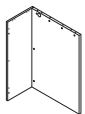

HNLLEP3041R shown



DESCRIPTION	MODEL	SHIP WEIGHT	CUBE	L1 LIST PRICE	L2 UPCHARGE
Laminate L-Shaped End Panels — For 42”H					
15¾”W x 30”D x 41”H, Right	HNLLEP3041R	55	4.3	\$416	\$20
15¾”W x 30”D x 41”H, Left	HNLLEP3041L	55	4.3	\$416	\$20
15¾”W x 24”D x 41”H, Right	HNLLEP2441R	47	2.8	\$372	\$20
15¾”W x 24”D x 41”H, Left	HNLLEP2441L	47	2.8	\$372	\$20

NOTES: Supports the end of a component worksurface where there is no modular pedestal. Provides easy, open access to wall electrical outlets. For configurations requiring a modesty panel, options include a laminate floating modesty panel or a mixed material floating modesty panel — see page 87. Tops and bottoms of panels are edgebanded. Two pieces; 1½” end panel and ¾” back panel. Ships simple assembly. Can be specified in a woodgrain or solid laminate color only; not available in a two-tone combination. See chart on page 36 for cord management options. If grommet option is chosen for the end panel, the color is black only.

SPECIFYING EXAMPLE: HNLLEP2428R.X.H

HOW TO SPECIFY

<p>Select Model Number</p> <p>H N L E P 3 0 7 R .</p>	<p>Select Laminate Color</p> <p>See page 29</p> <p>H</p>
---	--

<p>Select Model Number</p> <p>H N L L E P 3 0 2 8 R .</p>	<p>Select Grommet</p> <p>P Black X No Grommet</p> <p>X</p>	<p>Select Laminate Color</p> <p>See page 29</p> <p>H</p>
---	--	--



CONCINNITY™

Components — Supports

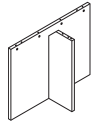
**DESCRIPTION****MODEL****SHIP WEIGHT****CUBE****L1
LIST PRICE****L2
UPCHARGE****Laminate T-Shaped End Panels — For 29½”H**

11⅝”W x 35⅞”D x 28½”H

HNLTEP3628

45

3.7

\$384**\$20**

11⅝”W x 29⅞”D x 28½”H

HNLTEP3028

39

3.3

\$360**\$20**

11⅝”W x 23⅞”D x 28½”H

HNLTEP2428

33

2.9

\$339**\$20**

NOTES: Supports the end of a component worksurface where there is no modular pedestal. Available in 24”, 30”, and 36”D x 28½”H. Two 1⅝” thick pieces; one end and one brace panel. Cord routing notch in brace panel. Non-handed. Ships ; simple assembly. Can be specified in a woodgrain or solid laminate color only; not available in a two-tone combination.

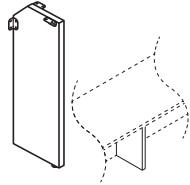
SPECIFYING EXAMPLE: HNLTEP3628.H**Support Brace — For 29½”H**

1⅝”W x 10½”D x 28½”H

HNL11SUPP

11

0.9

\$152**\$10**

NOTES: Minimizes worksurface deflection by providing added internal support under 24”D tops with an unsupported span of 54” or wider (distance for which there is no panel, leg, or pedestal support component). Not for use as an end panel. 11”D size provides kneespace clearance. Attaches with brackets to both the underside of the worksurface top and either a conventional full-length or 10” laminate modesty panel; not for use with O-leg or L-shaped end panel supports. 1⅝” thick. Cord routing notch in brace panel. Can be specified in a woodgrain or solid laminate color only.

SPECIFYING EXAMPLE: HNL11SUPP.H**HOW TO SPECIFY**
**Select
Model Number**

H	N	L	1	1	S	U	P	P
---	---	---	---	---	---	---	---	---

**Select
Laminate Color**

See page 29

H

CONCINNITY™

Components — Supports

GSA SIN 33721

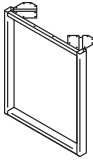
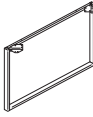
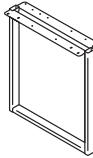
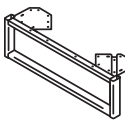
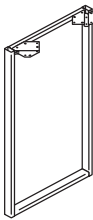
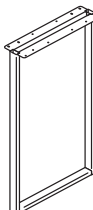

Icon Legend on page 19

	DESCRIPTION	MODEL	SHIP WEIGHT	CUBE	LIST PRICE BY PAINT GRADE		
					P1	P2	P3
	O-Leg 30"D x 28½"H 24"D x 28½"H	HLSL30280 ⓘ HLSL24280	19 17	5.4 3.7	\$359 \$324	\$363 \$328	\$379 \$344
	NOTES: Ship fully assembled, 1/pack. Non-handed. IMPORTANT: The O-leg attachment bracket interferes with placement of 28¾"H mobile pedestals, preventing them from being positioned directly next to (flush with) the O-leg. Box/file mobile pedestal (model HNL2116MBF) can be positioned along side the O-leg. SPECIFYING EXAMPLE: HLSL24280.T1						
	Double-Depth O-Leg Support for Worksurfaces 60"D x 28½"H 48"D x 28½"H	HLSL60280 HLSL48280	19 18	8.7 7.0	\$679 \$610	\$687 \$618	\$699 \$630
	NOTES: Ship fully assembled, 1/pack. Non-handed. 48"D and 60"D sizes span back-to-back 24"D and 30"D worksurfaces, respectively.						
	O-Leg Shared Support for Worksurfaces 30"D x 28½"H 24"D x 28½"H	HLSL3028SL ⓘ HLSL2428SL	19 17	5.4 3.7	\$447 \$402	\$451 \$406	\$467 \$422
	NOTES: Ship fully assembled, 1/pack. Non-handed. ⓘ Specify paint only. SPECIFYING EXAMPLE: HLSL2028SL.T1						
	O-Leg Support for Low Credenzas 30"D x 7"H 24"D x 7"H	HLSL3070 ⓘ HLSL2470	7 6	1.0 1.0	\$277 \$218	\$281 \$222	\$297 \$238
	NOTES: Ship fully assembled, 1/pack. Non-handed. For 7"H laminate support see page 92. ⓘ Specify paint only. SPECIFYING EXAMPLE: HLSL2070.T1						
	Standing-Height O-Leg Support for Worksurfaces 30"D x 41"H 24"D x 41"H	HLSL30410 HLSL24410	17 16	6.5 5.3	\$485 \$433	\$491 \$439	\$505 \$453
	NOTES: Ship fully assembled, 1/pack. Non-handed.						
	Standing-Height O-Leg Shared Support for Worksurfaces 30"D x 41"H 24"D x 41"H	HLSL3041SL HLSL2441SL	17 16	6.5 5.3	\$540 \$488	\$546 \$494	\$560 \$508
	NOTES: Ship fully assembled, 1/pack. Non-handed. For use with two 24"D or 30"D worksurfaces positioned side-by-side along the depth dimension.						

NOTES:



- Open frame, metal design.
- O-leg ships fully assembled with mounting hardware.
- O-leg glides have 2" adjustability.
- Will have 6" overhang when using 30"D O-legs with a 36"D worksurface.
- Shared O-legs create a cleaner aesthetic in all applications where two legs are used side-by-side.
- ⓘ O-legs may only be attached to worksurfaces, not storage units.
- ⓘ O-leg installation requires 6" of clearance from the worksurface end.
- ⓘ For use with worksurfaces up to 78"W. When using an 84"W or wider worksurface, cannot use two O-legs; must use one 15¾" or wider pedestal for the other support.

HOW TO SPECIFY

Select Model Number	Select Paint Color
HLSL30280	See page 173
T1	



CONCINNITY™ Components — Supports

	DESCRIPTION	MODEL	SHIP WEIGHT	CUBE	LIST PRICE
	Support Column 3" Diameter. Specify: HPC190X.P. Black only.	HPC190X	12 	1.0	\$161
	Support Column 3" Diameter. Specify: HPC191X.X. Available in Silver only.	HPC191X	12 	1.0	\$161

NOTES: For peninsula or island extension worksurface application.

	DESCRIPTION	MODEL	SHIP WEIGHT	CUBE	LIST PRICE BY PAINT GRADE	
					P1	P2
	Post Leg Base 28½"H x 2" square	HLSL28P	15	1.0	\$298	\$302
	NOTES: Can only be used as the outbound support in a peninsula or island extension worksurface application. Glides have 2" of adjustability. Ship 1/pack. SPECIFYING EXAMPLE: HLSL28P.T1					

NOTES:



- All bases allow tops to sit at 29½" from the floor with glides half-way seated.

Height Adjustable Base

- 3-Stage column design.
- Frame rises from 23¾" to 49¼" for a sit-to-stand desk option.
- Ships complete with a pre-assembled motor.
- Base telescopes to accommodate any worksurface between 48"W and 72"W.
- Accommodates rectangular worksurfaces between 24"D x 48"W and 30"D x 72"W.
- Standard height adjustable control ships with base.
- Dynamic load capacity when worksurface is moving is 300 lbs.
- Optional Memory Control allows preset worksurface heights for consistency. Ships separately.
- Silver finish matches any neutral HON paint or finish color.
- Tops and bases are ordered and sold separately.

Post and T-Leg Bases

- Both glides and casters attach to the foot easily without tools for assembly.
- Bases specified with casters include two locking and two non-locking casters.
- Bases specified with glides have four adjustable glides, which adjust 1".
- When post legs are used with 18"W tops, post leg to be specified with glides only.

-  Support column must be specified for worksurfaces used as peninsulas or as an island extension.
-  Post leg can only be used to support peninsula, not as primary supports for a top.

HOW TO SPECIFY

Select Model Number	Select Paint Color
	See page 173
H P C 1 9 0 X .	T 1

CONCINNITY™

Components — Supports

GSA SIN 33721

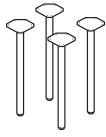

Icon Legend on page 19

**DESCRIPTION****Post Leg Base (Includes 4 Post Legs)**

24"D and 30"D Worksurfaces up to 72"W

MODEL**HMBPOST****SHIP WEIGHT**

18

CUBE

2.3

LIST PRICE**\$359**

NOTES: For 54" and 60" worksurfaces, use one external channel, centered between user and approach sides. For 66" and 72"W worksurfaces, use two external channels; if no grommets, locate the channels 3" from user and approach sides; if grommets are in the worksurface, locate channels 3" from user and 6" from approach sides.

1¾" diameter Post Leg Base with glide (HMBPOST.G); qty. 4; for 30" to 72"W x 24"D and 48" to 72"W x 30"D tops

1¾" diameter Post Leg Base with casters (HMBPOST.C); qty. 4; for 30" to 72"W x 24"D and 48" to 72"W x 30"D tops

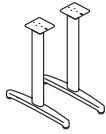
**Fixed Height T-Leg Base (Includes 2 T-legs)**

For 24"D and 30"D Worksurfaces up to 72"W

HMBTLEG24

14

3.6

\$426

NOTES: Use external channel when space between the two legs is 54"W or greater. Center the channel between approach and user sides. See model listing on page 84.

Fixed Height T-Leg Base with glide (HMBTLEG24.G); qty. 2; for 24" and 30"D tops up to 72"W; adjustable glides have 1" range

Fixed Height T-Leg Base with casters (HMBTLEG24.C); qty. 2; for 24" and 30"D tops up to 72"W; two locking and two non-locking casters

NOTES:

- All bases allow tops to sit at 29½" from the floor with glides half-way seated.

Post and T-Leg Bases

- Both glides and casters attach to the foot easily without tools for assembly.
- Bases specified with glides have four adjustable glides, which adjust 1".
- When post legs are used with 18"W tops, post leg to be specified with glides only.

⚠ Support column must be specified for worksurfaces used as peninsulas or as an island extension.

⚠ Post leg can only be used to support peninsula, not as primary supports for a top.

HOW TO SPECIFY**Select Model Number**

HMBTLEG24

Select Glide/Caster Option**G** Glide**C** Caster

18"D tops are not available in Concinnity™

G

Select Paint Color

See page 29

\$20 upcharge per model, for Metallic paint

T1



Icon Legend on page 19

CONCINNITY™ Height Adjustable Bases

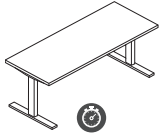

Base shown with work surface attached.

DESCRIPTION

Coordinate™ Height Adjustable Base – 3 Stage
24”D Feet and Worksurface Brackets

MODEL

HHAB3S2L *

SHIP WEIGHT

67

CUBE

2.4

LIST PRICE

\$1120

NOTES: Support option for 24” and 30” rectangle worksurfaces. Worksurfaces are ordered separately, see model listing on pages 80-81.

- ⓘ Telescoping horizontal frame will extend just over 2” from underside of the worksurface.
- ⓘ Coordinate™ Height Adjustable Bases not compatible with 36”D rectangular worksurfaces.
- ⓘ Removal of stretcher bars in Coordinate™ base is required when pairing with a 42”W worksurface.

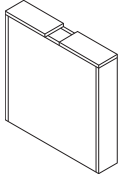

Not available in two-tone laminate.

SIN 33721

Shroud for Height Adjustable Base

5 1/8”W x 26”D x 26 1/4”H for Base with 30”D Top

HLAMSHB30

39

3.7

\$848

NOTES: Decorative laminate enclosure covers the Coordinate™ metal leg and foot. Lowest base adjustment position when the shroud is installed is 29 1/2”H; memory controller must be set at that height to avoid interference. For use with standard 10500 Series™, Concinnity™, and Voi® rectangle worksurfaces, 42-72”W x 30”D, supported by Height Adjustable Base models HHAB3S2L or HHAB2S2L. For height adjustable desks requiring a modesty panel, options include: 14”H laminate (HLSLXX14L) or mixed material (HLSLXX14MM) floating modesty panels, laminate full length (HNLMPXX28) or short (HNLMPXX10) modesty/back panel plus external support channel (HLSLZ5SCXX). External support channel attachment screws and modesty/back panel cover caps are included in the shroud hardware pack. External support channel size recommendation, specific to worksurface attached to Height Adjustable Base with optional laminate full-length or short modesty back/panel (HNLMPXX28/10) see below. Ships one per carton. To conceal both metal legs on the Height Adjustable Base order two. **When using a modesty panel set height adjustable table at 29”H to ensure table stops before hitting shroud.** Specify: Model.Laminate; see pages 236-237.

SPECIFYING EXAMPLE: HLAMSHB30.N

- ⓘ The Height Adjustable Base must be reset at the time of installation, after every loss of power, if the unit is not functioning properly, or if the legs are uneven. To reset the base requires removing the laminate shroud(s), as well as the full-length modesty panel if one is being used, then adjusting the base to its lowest position. Disassembly of the shroud is quick and easy.
- ⓘ \$25 upcharge for L2 laminates.

Worksurface Width	Modesty/Back Panel Width	External Support Channel
72”W	72”W	HLSLZ5SC78
66”W	66”W	HLSLZ5SC72
60”W	60”W	HLSLZ5SC66
54”W	54”W	HLSLZ5SC60
48”W	48”W	HLSLZ5SC54

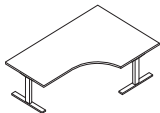

Base shown with work surface attached.

Coordinate™ 3-Leg Height Adjustable Base – 3 Stage

24”D Feet and Worksurface Brackets

HHAB3S3L *

91

3.6

\$1896

NOTES: Supports two rectangular worksurfaces to create a height adjustable L-shaped configuration. The 3-leg base supports corner covers or two-piece worksurfaces 41”-72”W x 35”-72”L x 23 1/4”-30”D. 48”W 120 degree corner worksurfaces are also supported. When using two worksurfaces, the connection between the two must be over the telescoping frame. Supports weight capacity of 375 lbs. (excluding worksurface weight).

- ⓘ Telescoping horizontal frame will extend just over 2” from underside of the worksurface.

NOTES:

Height Adjustable Base

- 3-Stage column design.
- Frame rises from 21 5/8” to 47 3/4” for a sit-to-stand desk option.
- Ships complete with a pre-assembled motor.
- Comes standard with one-touch, four memory controller with digital display; no specification needed, available in black finish only. See page 594 for additional control options.
- Base telescopes to accommodate any worksurface between 42”W and 72”W.
- Accommodates rectangular worksurfaces between 24”D x 48”W and 30”D x 72”W.
- Standard height adjustable control ships with base.
- Dynamic load capacity when worksurface is moving is 250 lbs.
- Tops and bases are ordered and sold separately.
- For additional information see page 198.
- **HON 7-Year Limited Warranty.**

ⓘ Worksurfaces used with Coordinate™ Height Adjustable Bases should have 1” perimeter gap on each side to provide clearance between other furniture. Failure to do so risks injury or product damage (not covered by warranty).

ⓘ See page 594 for additional Coordinate™ base models and options.

HOW TO SPECIFY

<p>Select Model Number</p>	<p>Select Finish</p> <p>P71 Black P8L Nickel PD8 White</p>
<p>H H A B 3 S 2 L .</p>	<p>P 8 L</p>

CONCINNITY™

Components — Privacy Screens

GSA SIN 33721

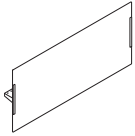

Icon Legend on page 19

**DESCRIPTION****Above/Below Privacy Screen**

60"W x 28"H
54"W x 28"H
48"W x 28"H
42"W x 28"H
36"W x 28"H
30"W x 28"H

MODEL

HLSL2860
HLSL2854
HLSL2848
HLSL2842
HLSL2836
HLSL2830

SHIP WEIGHT

9
9
8
6
6
6

CUBE

8.6
8.6
8.2
6.3
6.4
6.4

LIST PRICE

\$1426
\$1417
\$1217
\$1142
\$1129
\$816

NOTES: Attachment bracket extends 2" into top and underside of worksurface. Screen is frosted translucent acrylic. All brackets are platinum (no need to specify). Extends 13" above and 13" below worksurface.

❗ See page 99 for the "Above-Below Privacy Screen — HLSL28xx — Selection Guide".

❗ Available in Frosted Translucent Acrylic ONLY HLSL2830.FT01.

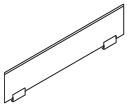
**Above Privacy Screen**

60"W x 13"H
54"W x 13"H
48"W x 13"H
42"W x 13"H
36"W x 13"H
30"W x 13"H

HLSL1260
HLSL1254
HLSL1248
HLSL1242
HLSL1236
HLSL1230

24
22
20
18
15
13

2.9
2.9
2.3
2.3
1.8
1.5

\$462
\$430
\$402
\$352
\$314
\$285

NOTES: Attachment requires 1" clear space/overhang on the underside of the worksurface. Screen is frosted glass. All brackets are platinum (no need to specify).

❗ Available in Frosted Glass ONLY HLSL1230.G.

❗ Above only privacy screen clamps onto worksurface and cannot be installed where support storage will be attached.

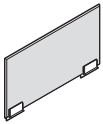
**Above Frosted Polymer (Side) Privacy Screen**

36"W x 13"H
30"W x 13"H
24"W x 13"H

HLSL1236FS
HLSL1230FS
HLSL1224FS

19 Ⓢ
16 Ⓢ
14 Ⓢ

1.9
1.6
1.4

\$406
\$363
\$336

NOTES: Attach to top and side of worksurface with adhesive banding. Platinum color brackets are intended to be attached between users sitting side-by-side. Brackets create a 1/8" separation between adjacent worksurfaces.

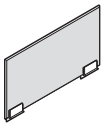
**Above Frosted Glass (Side) Privacy Screen**

36"W x 13"H
30"W x 13"H
24"W x 13"H

HLSL1236GS
HLSL1230GS
HLSL1224GS

20 Ⓢ
18 Ⓢ
16 Ⓢ

1.9
1.6
1.4

\$338
\$303
\$280

NOTES: Attach to top and side of worksurface with adhesive banding. Platinum color brackets are intended to be attached between users sitting side-by-side. Brackets create a 1/8" separation between adjacent worksurfaces.

NOTES:

- Ships complete with attachment brackets.
- All brackets are Platinum.
- Above Privacy Screen attaches to top of worksurface.
- Above and below privacy screen extends 13" above and 13" below the worksurface.
- ❗ Above screens must attach to edgeband and top of surface.
- ❗ Screens cannot be used with T-mold on series such as tables. Screens can only attach to edgeband. Surfaces must be cleaned prior to adhering the screen and must be left to cure for 24 hours without touching for best adhesion.

HOW TO SPECIFY**Select Model Number**

HLSL2830 .

HLSL1230 .

Select Mixed Material

FT01 Frosted Translucent Acrylic
Specified for Above/Below Privacy Screens only
G Frosted Glass
Specified for Above Privacy Screens only

FT01

G

Select Model Number

HLSL1224FS .

HLSL1224GS .

Select Mixed Material

FT01 Frosted Translucent Acrylic
Specified for Above Screen models HLSL1224FS-HLSL1236FS only
G Frosted Glass
Specified for Above Screen models HLSL1224GS-HLSL1236GS only

FT01

G

CONCINNITY™ PRIVACY SCREENS

HNL Above-Below Privacy Screen — HLSL28xx — Selection Guide

	Support Combination		Worksurface Width											
	Support 1	Support 2	30"	36"	42"	48"	54"	60"	66"	72"	78"	84"	90"	96"
O-LEG ON ONE END	O-Leg	O-Leg	NA	30	36	42	48	54	60	60	60	NA	NA	NA
	O-Leg	9½"W Ped	NA	NA	30	36	42	48	54	60	60	60	NA	NA
	O-Leg	End Bookcase	NA	NA	NA	30	36	42	48	54	60	60	60	NA
	O-Leg	L End Panel	NA	NA	NA	36	42	48	54	60	60	60	NA	NA
	O-Leg	15¾"W Ped	NA	NA	NA	30	36	42	48	54	60	60	60	NA
	O-Leg	18"W Ped	NA	NA	NA	NA	30	36	42	48	54	60	60	60
	O-Leg	30"W Ped	NA	NA	NA	NA	NA	NA	30	36	42	48	54	60
	O-Leg	36"W Ped	NA	NA	NA	NA	NA	NA	NA	30	36	42	48	54
NARROW PED	9½"W Ped	9½"W Ped	NA	NA	NA	NA	30	36	42	48	54	60	60	60
	9½"W Ped	End Bookcase	NA	NA	NA	NA	30	36	42	48	54	60	60	60
	9½"W Ped	L End Panel	NA	NA	NA	30	36	42	48	48	60	60	60	NA
	9½"W Ped	15¾"W Ped	NA	NA	NA	NA	NA	30	36	42	48	54	60	60
	9½"W Ped	18"W Ped	NA	NA	NA	NA	NA	30	36	42	48	54	60	60
	9½"W Ped	30"W Ped	NA	NA	NA	NA	NA	NA	NA	30	36	42	48	54
	9½"W Ped	36"W Ped	NA	NA	NA	NA	NA	NA	NA	NA	30	36	42	48
END BOOKCASE PED	End Bookcase	End Bookcase	NA	NA	NA	NA	30	36	42	48	54	60	60	60
	End Bookcase	L End Panel	NA	NA	NA	NA	30	36	42	48	54	60	60	60
	End Bookcase	15¾"W Ped	NA	NA	NA	NA	NA	30	36	42	48	54	60	60
	End Bookcase	18"W Ped	NA	NA	NA	NA	NA	30	36	42	48	54	60	60
	End Bookcase	30"W Ped	NA	NA	NA	NA	NA	NA	NA	30	36	42	48	54
	End Bookcase	36"W Ped	NA	NA	NA	NA	NA	NA	NA	NA	30	36	42	48
L END PANEL	L End Panel	L End Panel	NA	NA	NA	30	36	42	48	54	60	60	60	NA
	L End Panel	15¾"W Ped	NA	NA	NA	NA	30	36	42	48	54	60	60	60
	L End Panel	18"W Ped	NA	NA	NA	NA	NA	30	36	42	48	54	60	60
	L End Panel	30"W Ped	NA	NA	NA	NA	NA	NA	NA	30	36	42	48	54
	L End Panel	36"W Ped	NA	NA	NA	NA	NA	NA	NA	NA	30	36	42	48
TWO PEDS	15¾"W Ped	15¾"W Ped	NA	NA	NA	NA	NA	NA	30	36	42	48	54	60
	15¾"W Ped	18"W Ped	NA	NA	NA	NA	NA	NA	30	36	42	48	54	60
	15¾"W Ped	30"W Ped	NA	NA	NA	NA	NA	NA	NA	NA	30	36	42	48
	15¾"W Ped	36"W Ped	NA	NA	NA	NA	NA	NA	NA	NA	NA	30	36	42
	18"W Ped	18"W Ped	NA	NA	NA	NA	NA	NA	30	36	42	48	48	60
	18"W Ped	30"W Ped	NA	NA	NA	NA	NA	NA	NA	NA	30	36	42	48
	18"W Ped	36"W Ped	NA	NA	NA	NA	NA	NA	NA	NA	NA	30	36	42
	30"W Ped	30"W Ped	NA	NA	NA	NA	NA	NA	NA	NA	NA	NA	30	36
	30"W Ped	36"W Ped	NA	NA	NA	NA	NA	NA	NA	NA	NA	NA	NA	30
	36"W Ped	36"W Ped	NA	NA	NA	NA	NA	NA	NA	NA	NA	NA	NA	NA
HT ADJ BASE	Height Adjustable Base (model HHAB3S2L)		NA	NA	NA	42	48	54	60	60	NA	NA	NA	NA
RETURN CONFIGURATION	None	O-Leg	NA	30	36	42	48	54	60	60	60	NA	NA	NA
	None	9½"W Ped	NA	NA	30	36	42	48	54	60	60	60	NA	NA
	None	End Bookcase	NA	NA	NA	30	36	42	48	54	60	60	60	NA
	None	L End Panel	NA	NA	30	36	42	48	54	60	60	60	NA	NA
	None	15¾"W Ped	NA	NA	NA	30	36	36	48	54	60	60	60	NA
	None	18"W Ped	NA	NA	NA	NA	30	36	42	48	54	60	60	60
	None	30"W Ped	NA	NA	NA	NA	NA	NA	30	36	42	48	54	60
	None	36"W Ped	NA	NA	NA	NA	NA	NA	NA	30	36	42	48	54

NA = Above-Below Screen not applicable for use with worksurface width and support combination

CONCINNITY™ COMPONENTS — SUPPORTS

SUPPORT STORAGE PEDESTALS — 28½”H

- Non-handed, interchangeable design reconfigures easily.
- For use with component top and modesty/back panels or pedestal top and back panels.
 - Pedestals are not fully enclosed and require a component top/worksurface and modesty/back panel or a pedestal back, both of which must be ordered separately.
 - Pedestal’s front and side panels are finished.
- The pedestal depth dimension is less than the like-size depth of the component top, to accommodate addition of a modesty/back panel.
 - 29½”D pedestals can be used under 30” or 36”D worksurfaces; 23½”D pedestals can be used under 24” or 30”D worksurfaces.
 - When specifying a 29½”D pedestal with ¾” modesty panel under a 36”D worksurface, or a 23½”D pedestal with a ¾” modesty panel under a 30”D worksurface, there will be a 6” approach side overhang.
- Bottom of side panels are edgebanded for added strength and to seal out moisture.
- Drawers:
 - Operate on steel ball-bearing suspensions to ensure smooth, quiet, long-lasting operation; full extension allows easy access to contents.
 - Fronts are edgebanded on all four sides.
 - Feature 5-sided construction for added strength and easy alignment or replacement of drawer fronts.

- Interchangeable core removable locks are located on front of all modular storage products, except the storage cabinet.
- Finish of lock is determined by, and aligned with, the handle finish specified.
- Locks feature a removable cylinder that can be interchanged as needed; allows users to access all furniture pieces in an office with a single key for convenience and security. Makes re-keying quick and easy. Keyed alike cores must be ordered separately by specification of the key number (removable lock core kit models available in Black [model HF23B] or Satin [model HF23S]).
- Ship fully assembled.
- Chassis and drawer front colors are specified separately; can be selected with common woodgrain or solid laminate color, or with different, complementary chassis and drawer/door colors.
- See chart on page 36 for cord management options. If the pedestal grommet option is chosen, two cutouts, one per end/side panel, each with a black plastic cap, are included.

SUPPORT STORAGE PEDESTALS — 41”H STANDING-HEIGHT

- Same as above except — not to be used freestanding; top and back are not enclosed.
 - Rear of pedestal can be enclosed with a full, 40¾”H back panel or with a 27⅞”H modesty panel combined with a lower, 13”H pedestal back component. Pedestal back and modesty panel must be ordered separately.



CONCINNITY™

Components — Supports

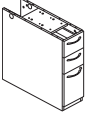
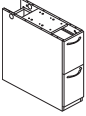
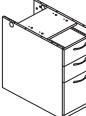
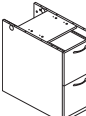
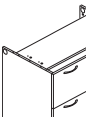
	DESCRIPTION	MODEL	SHIP WEIGHT	CUBE	L1 LIST	L2 UPCHARGES	
						CHASSIS	FRONTS
	Narrow Box/Box/File Pedestal 9½"W x 29⅞"D x 28½"H	HNL291028PBBF	64	10.6	\$787	\$25	\$10
	9½"W x 23⅞"D x 28½"H	HNL231028PBBF	53	8.6	\$705	\$20	\$10
NOTES: Efficient, space saving design for smaller footprints. Three locking drawers; two box (supply) drawers, one for files. File drawer has high sides to accept hanging folders; hangrails are included for side-to-side letter or legal filing. Pedestal's top and back are open and require top and back panel components — ordered separately. See chart on page 36 for cord management options. Ships fully assembled. SPECIFYING EXAMPLE: HNL291028PBBF.E.X.H.H							
	Narrow File/File Pedestal 9½"W x 29⅞"D x 28½"H	HNL291028PFF	69	10.6	\$787	\$25	\$10
	9½"W x 23⅞"D x 28½"H	HNL231028PFF	54	10.6	\$705	\$20	\$10
NOTES: Efficient, space saving design for smaller footprints. Two locking file drawers. Drawers have high sides to accept hanging folders; hangrails are included for side-to-side letter or legal filing. Pedestal's top and back are open and require top and back panel components — ordered separately. See chart on page 36 for cord management options. Ships fully assembled. SPECIFYING EXAMPLE: HNL291028PFF.E.X.H.H							
	Box/Box/File Pedestal 15¾"W x 29⅞"D x 28½"H	HNL291628PBBF	76	10.6	\$799	\$25	\$10
	18"W x 23⅞"D x 28½"H	HNL231828PBBF	72	9.8	\$802	\$20	\$10
	15¾"W x 23⅞"D x 28½"H	HNL231628PBBF	69	8.6	\$728	\$20	\$10
NOTES: Three locking drawers; two box (supply) drawers, one for files. File drawer has high sides to accept hanging folders; hangrails are included for side-to-side letter or legal filing; and front-to-back for letter filing. Pedestal's top and back are open and require top and back panel components — ordered separately. See chart on page 36 for cord management options. Ships fully assembled. SPECIFYING EXAMPLE: HNL291628PBBF.E.X.H.H							
	File/File Pedestal 15¾"W x 29⅞"D x 28½"H	HNL291628PFF	78	10.6	\$799	\$25	\$10
	18"W x 23⅞"D x 28½"H	HNL231828PFF	72	9.8	\$802	\$20	\$10
	15¾"W x 23⅞"D x 28½"H	HNL231628PFF	70	8.6	\$728	\$20	\$10
NOTES: Two locking file drawers. Drawers have high sides to accept hanging folders; hangrails are included for side-to-side letter or legal filing; and front-to-back for letter filing. Pedestal's top and back are open and require top and back panel components — ordered separately. See chart on page 36 for cord management options. Ships fully assembled. SPECIFYING EXAMPLE: HNL291628PFF.E.X.H.H							
	Lateral File Pedestal 36"W x 23⅞"D x 28½"H	HNL233628PLF	134	18.4	\$1077	\$40	\$20
	30"W x 23⅞"D x 28½"H	HNL233028PLF	115	15.0	\$983	\$35	\$20
NOTES: Two locking file drawers; drawers include hangrails to accept folders in letter or legal size. For use under 24"D rectangle worksurface. Widths can also span depth dimension of respective 30" or 36"D rectangle worksurface. Anti-tip design includes mechanical interlock to inhibit the extension of more than one drawer at a time. Pedestal's top and back are open and require top and back panel components — ordered separately. See chart on page 36 for cord management options. Ships fully assembled. SPECIFYING EXAMPLE: HNL233628PLF.E.X.H.H							

NOTES:

- 29⅞"D pedestals can be used under 30" or 36"D worksurfaces; 23⅞"D pedestals can be used under 24" or 30"D worksurfaces.
- Drawers operate on steel ball-bearing suspensions to ensure smooth, quiet, long-lasting operation; full extension allows easy access to contents.
- Interchangeable core removable locks allow users to access all furniture pieces in an office with a single key for convenience and security. Makes re-keying quick and easy.
- See chart on page 36 for cord management options. If the pedestal grommet option is chosen, two cutouts, one per end/side panel, each with a black plastic cap, are included.

! Pedestal tops and backs are open and require top and back panel components — ordered separately.

! 9½"W pedestals are not designed to be used independently in a stand-alone application.

HOW TO SPECIFY

Select Model Number	Select Handle	Select Grommet	Select Chassis Color	Select Drawer Front Color
A B C D E F	A Cylinder – Satin B Cylinder – Black C Canopy – Satin D Canopy – Black E Loop – Satin F Loop – Black	P Black X No Grommet	See page 29	See page 29
H N L 2 9 1 0 2 8 P B B F .	E .	X .	H .	H

CONCINNITY™

Components — Supports

GSA SIN 33721

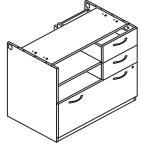

Icon Legend on page 19

**DESCRIPTION****Shelf/Box/Box/Lateral File Pedestal**

36"W x 23½"D x 28½"H

30"W x 23½"D x 28½"H

MODEL**HNL233628PSL****HNL233028PSL****SHIP WEIGHT**

145

126

CUBE

18.4

15.0

L1 LIST**\$1270****\$1246****L2 UPCHARGES****CHASSIS****\$40****\$35****FRONTS****\$20****\$20**

NOTES: Versatile unit features an open shelf and three drawers; two for supplies and one for files. For use under 24"D rectangle worksurface. Widths can also span depth dimension of respective 30" or 36"D rectangle worksurface. Box (supply) drawers are located on the right and open shelves on the left. All drawers lock. Pedestal's top and back are open and require top and back panel components — ordered separately. See chart on page 36 for cord management options. Ships fully assembled.

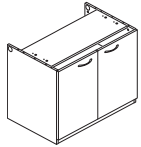
SPECIFYING EXAMPLE: HNL233628PSL.E.X.H.H**Storage Cabinet Pedestal**

36"W x 23½"D x 28½"H

30"W x 23½"D x 28½"H

HNL233628PSC**HNL233028PSC**

104

91

18.4

15.0

\$826**\$799****\$40****\$35****\$20****\$20**

NOTES: One adjustable shelf, which adjusts in 2½" increments. For use under 24"D rectangle worksurface. Widths can also span depth dimension of respective 30" or 36"D rectangle worksurface. Doors are non-locking. Pedestal's top and back are open and require top and back panel components — ordered separately. See chart on page 36 for cord management options. Ships fully assembled.

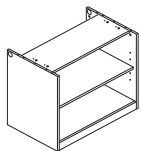
SPECIFYING EXAMPLE: HNL233628PSC.E.X.H.H**Bookcase Pedestal**

36"W x 23½"D x 28½"H

30"W x 23½"D x 28½"H

HNL233628PBK**HNL233028PBK**

82

73

18.4

15.0

\$726**\$710****\$40****\$35****N/A****N/A**

NOTES: Two shelves; bottom of unit plus one adjustable shelf, which adjusts in 2½" increments. For use under 24"D rectangle worksurface. Widths can also span depth dimension of respective 30" or 36"D rectangle worksurface. Pedestal's top and back are open and require top and back panel components — ordered separately. See chart on page 36 for cord management options. Ships fully assembled.

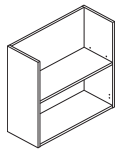
SPECIFYING EXAMPLE: HNL233628PBK.X.H**Bookcase End Support**

12"W x 36"D x 28½"H

12"W x 30"D x 28½"H

12"W x 24"D x 28½"H

HNL123628BKE**HNL123028BKE****HNL122428BKE**

48

48

41

11.0

10.2

7.4

\$546**\$518****\$491****\$25****\$20****\$20****N/A****N/A****N/A**

NOTES: Two shelves; bottom of unit plus one adjustable shelf, which adjusts in 1¼" increments. Designed to span the depth dimension of 24", 30", or 36"D rectangle worksurface; shelves can be oriented facing outwards, or inwards towards the user's kneespace. Includes fully finished back. Ships with two (2) extra L-brackets for applications requiring attachment of a laminate modesty panel; the panel brackets to the back of the bookcase end support. Modesty panel specified should be 12" less than the worksurface width. Open top; for use under worksurface only — ordered separately. Ships fully assembled.

SPECIFYING EXAMPLE: HNL123628BKE.H**NOTES:**

- 23½"D pedestals can be used under 24" or 30"D worksurfaces.
- Drawers operate on steel ball-bearing suspensions to ensure smooth, quiet, long-lasting operation; full extension allows easy access to contents.
- Interchangeable core removable locks allow users to access all furniture pieces in an office with a single key for convenience and security. Makes re-keying quick and easy.
- See chart on page 36 for cord management options. If the pedestal grommet option is chosen, two cutouts, one per end/side panel, each with a black plastic cap, are included.

! Pedestal tops and backs are open and require top and back panel components — ordered separately.

HOW TO SPECIFY

Select Model Number H N L 2 3 3 6 2 8 P S L .	Select Handle A Cylinder – Satin B Cylinder – Black C Canopy – Satin D Canopy – Black E Loop – Satin F Loop – Black E .	Select Grommet P Black X No Grommet X .	Select Chassis Color See page 29 H .	Select Drawer Front Color See page 29 H
---	---	---	---	--



CONCINNITY™

Components — Supports

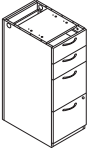
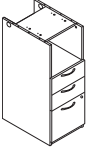
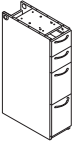
	DESCRIPTION	MODEL	SHIP WEIGHT	CUBE	L1 LIST	L2 UPCHARGES	
						CHASSIS	FRONTS
	Box/Box/File/File Pedestal						
	15¾"W x 29⅞"D x 41"H	HNL291641PBBFF	114	14.7	\$1635	\$45	\$10
	15¾"W x 23⅞"D x 41"H	HNL231641PBBFF	102	11.9	\$1534	\$40	\$10
	NOTES: Four drawers: two box (supply) and two file. File drawer has high sides to accept hanging folders; hangrails are included for side-to-side letter or legal filing; and front-to-back for letter filing. The two box drawers do not lock. Pedestal's top and back are open and require top and back panel components — ordered separately. See chart on page 36 for cord management options. Ships fully assembled. SPECIFYING EXAMPLE: HNL291641PBBFF.E.X.H.H						
	Shelf/Box/Box/File Pedestal						
	15¾"W x 29⅞"D x 41"H	HNL291641PSBBF	99	14.7	\$1635	\$45	\$10
	15¾"W x 23⅞"D x 41"H	HNL231641PSBBF	89	11.9	\$1534	\$40	\$10
	NOTES: Open shelf over three drawers: two box (supply) and one file. Interior dimensions of the open storage area are: 14⅞"W x 28¼"D x 12¼"H for the 29⅞"D pedestal. 14⅞"W x 22¼"D x 12¼"H for the 23⅞"D pedestal. File drawer has high sides to accept hanging folders; hangrails are included for side-to-side letter or legal filing; and front-to-back for letter filing. All drawers lock. Pedestal's top and back are open and require top and back panel components — ordered separately. See chart on page 36 for cord management options. Ships fully assembled. SPECIFYING EXAMPLE: HNL291641PSBBF.E.X.H.H						
	Narrow Box/Box/File/File Pedestal						
	9½"W x 29⅞"D x 41"H	HNL291041PBBFF	88	14.7	\$1439	\$45	\$20
	9½"W x 23⅞"D x 41"H	HNL231041PBBFF	79	11.9	\$1349	\$40	\$20
	NOTES: Efficient, space saving design for smaller footprints. Four drawers: two box (supply) and two file. File drawers have high sides to accept hanging folders; hangrails are included for side-to-side letter or legal filing. When used in a double pedestal configuration under a 60" and 48"W worksurface, provides 41" and 29" of kneespace width, respectively. The two box drawers do not lock. Pedestal's top and back are open and require top and back panel components — ordered separately. See chart on page 36 for cord management options. Ships fully assembled. SPECIFYING EXAMPLE: HNL291041PBBFF.E.X.H.H						

NOTES:

- Pedestals for standing-height workstations.
- 29⅞"D pedestals can be used under 30" or 36"D worksurfaces; 23⅞"D pedestals can be used under 24" or 30"D worksurfaces.
- Drawers operate on steel ball-bearing suspensions to ensure smooth, quiet, long-lasting operation; full extension allows easy access to contents.
- See chart on page 36 for cord management options. If the pedestal grommet option is chosen, two cutouts, one per end/side panel, each with a black plastic cap, are included.

- ! Pedestal tops and backs are open and require top and back panel components — ordered separately.
- ! 9½"W pedestals are not designed to be used independently in a stand-alone application.

HOW TO SPECIFY

Select Model Number	Select Handle	Select Grommet	Select Chassis Color	Select Drawer Front Color
	A Cylinder – Satin B Cylinder – Black C Canopy – Satin D Canopy – Black E Loop – Satin F Loop – Black	P Black X No Grommet	See page 29	See page 29
H N L 2 9 1 6 4 1 P B B F F .	E .	X .	H .	H .

CONCINNITY™ Components — Pedestal Tops

GSA SIN 33721



Icon Legend on page 19

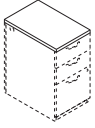

DESCRIPTION	MODEL	SHIP WEIGHT	CUBE	L1 LIST PRICE	L2 UPCHARGE
Pedestal Tops					
15¾"W x 30"D	HNLPT3016	16	1.4	\$236	\$10
18"W x 24"D	HNLPT2418	15	1.3	\$221	\$10
15¾"W x 24"D	HNLPT2416	13	1.2	\$221	\$10

NOTES: Component is 1½" thick. Underside of top includes pilot mounting holes for pedestals. Grain direction on 15¾" and 18"W pedestal tops runs horizontal (side-to-side). Component tops for 30" and 36"W pedestals are listed with rectangle worksurface sizes. Grain direction on 30" and 36"W pedestal tops can be specified horizontal (side-to-side) or vertical (front-to-back). For tri-oval and beaded edge options, there is a shaped profile on the user and approach sides, and a flat edge on the ends.

- ⓘ For modular pedestals used in freestanding applications; not compatible when pedestal is positioned under a worksurface.
- ⓘ 9½"W pedestals are not designed to be used independently in a freestanding application, so 9½"W tops are not available to order.

HOW TO SPECIFY

Select Model Number

H N L P T 3 0 1 6 .

Select Edge Profile and Edge Color

See page 29

B H .

Select Top Color

See page 29

H



CONCINNITY™

Components — Pedestal Back Panels

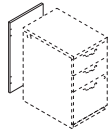
**DESCRIPTION****MODEL****SHIP WEIGHT****CUBE****L1 LIST PRICE****L2 UPCHARGE****Full Back Panels — For 28½”H Pedestals**

18”W x 27⅞”H

HNLBP1828

11

1.5

\$152**\$10**

15¾”W x 27⅞”H

HNLBP1628

10

1.3

\$136**\$10**

9½”W x 27⅞”H

HNLBP1028

6

0.9

\$129**\$10**

NOTES: Encloses the rear of 28½”H modular support pedestals, which come standard with an open, unfinished back. For use when a support storage pedestal is positioned under a 29½”H worksurface and a conventional worksurface width x 27⅞”H modesty/back panel is not specified to cover the back of the pedestal. Examples of when to use a 27⅞” pedestal back include: A worksurface supported by an O-leg on one end and support pedestal on the other, with open wall access; or a worksurface with an O-leg and pedestal support flanking a floating modesty panel. Can be specified in a woodgrain or solid laminate color only. For 30” and 36”W pedestals, use the respective modesty/pedestal back panel size, see page 86.

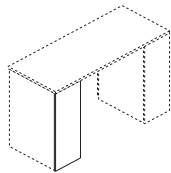
SPECIFYING EXAMPLE (9½”, 15¾”, 18”W): HNLBP1028.H

Back View

Full Back Panels — For 41”H Pedestals

15¾”W x 40⅜”H

HNLBP1641

15

1.8

\$156**\$15**

9½”W x 40⅜”H

HNLBP1041

9

1.2

\$142**\$15**

NOTES: Encloses the rear of 41”H modular support pedestals, which come standard with an open, unfinished back. For use when a support storage pedestal is positioned under a 42”H worksurface and no full-width, 27⅞”H laminate modesty and low, 13”H pedestal back panel are specified. Examples of when to use a 40⅜” pedestal back include: A worksurface supported by an O-leg on one end and support pedestal on the other, with open wall access; or a worksurface with an O-leg and pedestal support flanking a floating modesty panel. Can be specified in a woodgrain or solid laminate color only.

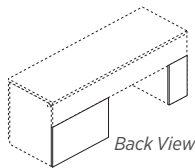
SPECIFYING EXAMPLE: HNLBP1641.H

Back View

Shown with HNLB3018 and HNLB1018

Low Back Panels — For 28½”H Pedestals

36”W x 18”H

HNLB3618

15

1.9

\$152**\$15**

30”W x 18”H

HNLB3018

12

1.6

\$152**\$15**

18”W x 18”H

HNLB1818

7

1.0

\$136**\$15**

15¾”W x 18”H

HNLB1618

6

0.9

\$131**\$10**

9½”W x 18”H

HNLB1018

4

0.6

\$122**\$10**

NOTES: Encloses the rear of 28½”H modular support pedestals when positioned under a 29½”H worksurface with a full-width, 10” laminate modesty panel. The modesty panel extends down from the underside of the worksurface to cover the upper back portion of the pedestal, the lower panel component encloses the remainder of the pedestal back. When used in combination, the 10” modesty and pedestal low back panels fully conceal the rear of the pedestal. The pedestal low back panel is only for use when a modular pedestal is used in conjunction with a worksurface with a 10” laminate modesty panel and the customer wants/needs to fully enclose the back section of the pedestal. Can be specified in a woodgrain or solid laminate color only.

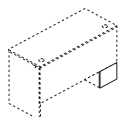

Back View

Low Back Panels — For 41”H Pedestals

15¾”W x 13”H

HNLB1613

4

0.7

\$131**\$10**

9½”W x 13”H

HNLB1013

3

0.5

\$122**\$10**

NOTES: Encloses the rear of 41”H modular support pedestals when positioned under a 42”H worksurface with a full-width, 27⅞” laminate modesty panel. The modesty panel extends down from the underside of the worksurface to cover the upper back portion of the pedestal, the lower panel component encloses the remainder of the pedestal back. When used in combination, the 27⅞” modesty and pedestal low back panels fully conceal the rear of the pedestal. The pedestal low back panel is only for use when a modular pedestal is used in conjunction with a worksurface with a 27⅞” laminate modesty panel and the customer wants/needs to fully enclose the back section of the pedestal. Can be specified in a woodgrain or solid laminate color only.

HOW TO SPECIFY**Select Model Number**

H N L P B 1 8 2 8

Select Laminate Color

See page 29

H

Select Model Number

H N L L B 3 6 1 8

Select Laminate Color

See page 29

H



Refer to page 106 for Center Drawer compatibility information

DESCRIPTION	MODEL	SHIP WEIGHT	CUBE	L1 LIST PRICE	L2 UPCHARGE
Laminate Center Drawer					
26" x 15 ³ / ₈ "	H1526	12 Ⓞ	1.2	\$198	\$15
22" x 15 ³ / ₈ "	H1522	11 Ⓞ	1.1	\$184	\$15
<ul style="list-style-type: none"> • 12" drawer extension (3/4). • Inside drawer dimension for H1526: 22⁷/₈"W x 15¹/₂"D x 1¹/₂"H. • Inside drawer dimension for H1522: 18⁷/₈"W x 15¹/₂"D x 1¹/₂"H. • Minimum clearance for mounting H1526: 27¹/₄"W x 18¹/₂"D compatible with 72"W x 36"D, 66"W x 30"D, 60"W x 30"D Double Pedestal Desks, 72"W x 24"D, 66"W x 24"D, 60"W x 24"D Credenza w/Kneespace, 48"W x 24"D Return • Minimum clearance for mounting H1522: 22³/₄"W x 18¹/₂"D compatible with 72"W x 36"D, 66"W x 30"D, 60"W x 30"D Double Pedestal Desks, 72"W x 36"D, 66"W x 30"D Single Pedestal Desks, Bullet and P-shaped Peninsulas, 72"W x 24"D, 66"W x 24"D, 60"W x 24"D Credenza w/Kneespace, 72"W x 24"D, 66"W x 24"D Single Pedestal Credenzas, 48"W x 24"D, 42"W x 24"D Returns <p>NOTES: Specify laminate for drawer. Model H1522 or H1022 can be used on peninsulas with modesty panel, model HPC180W. Laminate center drawers include pencil tray. For center drawer laminate colors, see page 29.</p>					

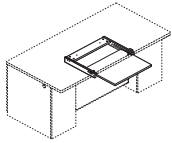

DESCRIPTION	MODEL	SHIP WEIGHT	CUBE	L1 LIST PRICE	L2 UPCHARGE
Collaborative Desk Shelf					
25"W x 23"D x 2 ¹ / ₂ "H	HNLCDSEHF	18	1.5	\$345	\$20
<p>NOTES: Convenient slide-out shelf on approach-side of desk provides workspace for guests. For use with 72"W x 36"D breakfront desk designs — see listings on page 43 — or with 60" or wider worksurface, supported by pedestals, and no modesty panel. Minimum clearance for mounting: 28"W x 19³/₄"D. Fully extended shelf dimensions: 24"W x 19"D. Shelf extends 12³/₈". ³/₄" thick. Not compatible on desks with under-surface center drawer or keyboard platform attached. Can be specified in a woodgrain or solid laminate color only.</p> <p>! Collaborative desk shelf for use with 72"W x 36"D breakfront, floating modesty panel desk designs or with 60" or wider worksurface, supported by pedestals, and no modesty panel.</p> <p>SPECIFYING EXAMPLE: HNLCDSEHF.H</p>					

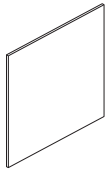

DESCRIPTION	MODEL	SHIP WEIGHT	CUBE	LIST PRICE
Wall Mount Tackboard				
36"W x 35 ¹ / ₄ "H	HNL3636TB	20	2.9	\$300
30"W x 35 ¹ / ₄ "H	HNL3630TB	16	2.9	\$256
36"W x 48 ⁵ / ₈ "H	HNL4936TB	27	5.5	\$334
30"W x 48 ⁵ / ₈ "H	HNL4930TB	22	3.7	\$290
<p>NOTES: For a list of standard fabrics, see pages 25-26. For a complete list of fabrics, please go to hon.com/fabricsandfinishes. When positioned above 29¹/₂"H floor-standing storage, the sizes align with overhead storage height options. Can be positioned side-by-side with corresponding wall mount markerboard sizes. Easy to install; includes mounting hardware. Attaches to wall with horizontally mounted, interlocking Z-clip brackets. For the space directly below stack-on and wall mount storage cabinets, use the 18"H tackboard models listed on Pricer pages 59 and 65.</p> <p>SPECIFYING EXAMPLE: HNL3636TB.APN15</p>				

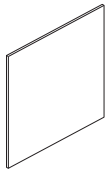

DESCRIPTION	MODEL	SHIP WEIGHT	CUBE	LIST PRICE
Wall Mount Markerboard				
36"W x 35 ¹ / ₄ "H	HNL3636WB	16	2.9	\$205
30"W x 35 ¹ / ₄ "H	HNL3630WB	14	2.9	\$191
36"W x 48 ⁵ / ₈ "H	HNL4936WB	22	5.5	\$251
30"W x 48 ⁵ / ₈ "H	HNL4930WB	20	3.7	\$231
<p>NOTES: Smooth, white, magnetic surface. Metal material produces clear graphics and cleans easily. Compatible for use with dry- or wet-erase markers. When positioned above 29¹/₂"H floor-standing storage, the sizes align with overhead storage height options. Can be positioned side-by-side with corresponding wall mount tackboard sizes. Easy to install; includes mounting hardware. Attaches to wall with horizontally mounted, interlocking Z-clip brackets.</p> <p>SPECIFYING EXAMPLE: HNL3636WB</p>				

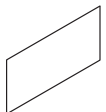

DESCRIPTION	MODEL	SHIP WEIGHT	CUBE	LIST PRICE
Markerboard				
36"W x 15"D	HLSL1536SOMB	8	1.0	\$179
30"W x 15"D	HLSL1530SOMB	6	1.0	\$132
<p>NOTES: Markerboard laminate material with black edges, no frame. Adheres to laminate doors. Includes double-sided tape. No specification necessary.</p>				

HOW TO SPECIFY

Select Model Number	Select Laminate Color
	See page 29
H N L C D S H E L F .	H

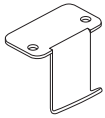

DESCRIPTION

Back Pack Hook (10 per carton)

12"W x 14½"D x 1½"H

NOTES: Assembly: attaches to bottom of desk with (2) screws, included.

ⓘ Available in Platinum Metallic finish only, no specification needed.

MODEL

HCLA65

SHIP WEIGHT

10

CUBE

0.1

LIST PRICE

\$95

HOW TO SPECIFY

Select
Model Number

H C L A 6 5



Black only

SIN 33721

DESCRIPTION**MODEL****SHIP WEIGHT****CUBE****LIST PRICE****Field Installable Grommet — For 2½" Diameter Hole****HFLDGRMT**

0.1 Ⓢ

0.01

\$32

- Intended for use in tops and end panels to route/hide cords and in modesty panels to facilitate reaching wall electrical outlets.
- Grommet is field installable.
- Requires a 2½" diameter hole saw and drill for installation (not included).
- Grommet shape is round.
- Includes grommet cap and sleeve.
- Grommet cap measures 3" diameter and includes a ¾" diameter cord access hole.
- Grommet sleeve measures 2½" O.D. x ¾" thick.
- Includes instructions to locate grommet position for desks, credenzas, returns, and bridges.

! Black Finish

SPECIFYING EXAMPLE: HFLDGRMT

SIN 33721

Field Installable Grommet — For 3" Diameter Hole**HFLDGRMT3**

0.1 Ⓢ

0.3

\$32

- Intended for use in tops and end panels to route/hide cords and in modesty panels to facilitate reaching wall electrical outlets.
- Grommet is field installable.
- Requires a 3" diameter hole saw and drill for installation (not included).
- Grommet shape is round.
- Includes grommet cap and sleeve.
- Grommet outside dimensions measures 3½" diameter and includes two cord access holes.
- Grommet sleeve measures 3" O.D. x 1" thick.
- Includes instructions to locate grommet position for desks, credenzas, returns, and bridges.

! Black Finish

SPECIFYING EXAMPLE: HFLDGRMT3

OPEN MARKET

Field Installable Grommet — For 3" Diameter Hole**HFLDGRMT4**

0.1

0.01

\$32

- Intended for use in tops to route/hide cords.
- Requires a 3" diameter hole saw and drill for installation (not included).
- Includes grommet cap, with two access holes, and sleeve components.
- Outside dimension measures 3½" diameter.
- Sleeve hole in worksurface measures 3" O.D. x 1" thick.
- Includes instructions to locate grommet position for desks, credenzas, returns, and bridges.

! Platinum Finish

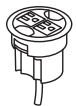
SPECIFYING EXAMPLE: HFLDGRMT4

SIN 33721T

Power Hub, 3" Grommet Mount, 6' Cord**HGRMTAC**

1.3

0.2

\$116

- Fits in 3" round grommet holes on the following product lines: 10500, 10700, Concinnity, Coordinate, and Voi desks; Abound Worksurfaces; Huddle and Motivate tables and SmartLink.
- Two grounded AC power outlets.
- Two cord pass-through holes in cap.
- Includes 6' cord with three-prong plug.
- Field installed; easy plug-and-play.
- UL Listed.

! Available in black only (no color designation so use .X - Specify: HGRMTAC.X).

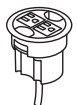

SIN 33721T

3" Round Power Grommet — 2 Outlets, 10' Cord**HGRMTAC2**

1.5

0.2

\$148

- Includes 10' cord with three-prong plug.
- Fits in 3" round grommet holes on the following product lines: Coordinate, Huddle, Motivate, all laminate and veneer casegoods series, and Systems Worksurfaces.
- Two grounded AC power outlets.
- Field installed with Plug-and-play ease.

NOTES: Power Modules will also work with standing-height applications for 10500 Series™ and Voi® desks. Optional Memory Control allows preset worksurface heights for consistency. Ships separately. Dynamic load capacity when worksurface is moving is 300 lbs.

! Available in black finish only, no specification needed.



SIN 33721T

Power/USB Hub, 3" Grommet Mount**HGRMTUSB2**

1.3 Ⓢ

0.2

\$226

- One grounded AC power outlet with 2 USB ports.
- Two cord pass-through holes in cap.
- Includes 6' cord with three-prong plug.
- Field installed; easy plug-and-play.
- UL Listed.

! Available in black only (no color designation so use .X - Specify: HGRMTUSB2.X).





HOW TO SPECIFY

Select Model Number

HGRMTAC

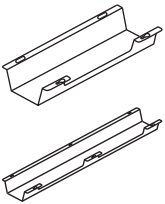

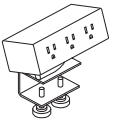
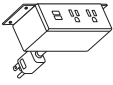
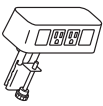
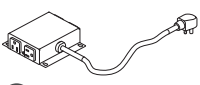
Icon Legend on page 19

	DESCRIPTION	MODEL	SHIP WEIGHT	CUBE	LIST PRICE
	Cable Management Troughs				
	17"W — Single 17"W — 10-Pack 36"W — Single 36"W — 10-Pack <ul style="list-style-type: none"> Cable management troughs ship flat packed. The troughs attach to underneath the worksurface with screws. The 17"W has one wire access cut out on the user side. The 36" has two wire access cut outs. These cut outs give users access to inside the trough without having to detach it from the worksurface. Color: Graphite. Material: Metal. TAA Compliant. 	HCTROUGH17 HCTROUGH1710 HCTROUGH36 HCTROUGH3610	2.7 Ⓢ 14.0 Ⓢ 4.9 Ⓢ 30.0 Ⓢ	0.5 0.5 0.9 0.9	\$67 \$620 \$113 \$1045
 <p>OPEN MARKET</p>	O-Leg Cord Clips				
	Clips for 28½" Worksurface O-Legs — 8-Pack Clips for Layering O-Legs — 4-Pack NOTES: Wire clips work with 7" Low Credenza O-leg and 29"H Support O-leg. ⓘ Available in frosted plastic material only.	HWMCLIPLG HWMCLIPSM	0.8 Ⓢ 0.5 Ⓢ	0.1 0.1	\$99 \$65
 <p>Model HPWRMOD3WC shown</p>  <p>Model HPWRMOD2UWM shown</p>	Power Modules				
	3 Receptacles with Worksurface Clamp 3 Receptacles with Under-Worksurface Mounting Bracket 2 Receptacles 2 USB with Worksurface Clamp 2 Receptacles 2 USB with Under-Worksurface Mounting Bracket <ul style="list-style-type: none"> 6' power cord with standard three-prong plug. Under-worksurface mounting bracket models work with any top that has a 5" x 5" square clearance. Worksurface clamp models work on any top with a 4" overhang. UL Listed. ⓘ Color finish coordinates with HON's Charcoal or White. Specify STRM for Storm or SNW for Snow when ordering. Example: HPWRMOD3WC.STRM.	HPWRMOD3WC HPWRMOD3UWM HPWRMOD2WC HPWRMOD2UWM	2.3 Ⓢ 2.3 Ⓢ 2.3 Ⓢ 2.3 Ⓢ	0.2 0.2 0.2 0.2	\$310 \$310 \$496 \$496
	Power & Data Center				
	2 Receptacles 2 Data Accessory <ul style="list-style-type: none"> Standard with two receptacles and openings for two data ports. 6' power cord with standard three-prong plug. Fits on any worksurface with a 4" overhang. UL Listed. ⓘ Color finish coordinates with HON's Loft. Specify LOFT when ordering. Example: HCOMDOME2.LOFT.	HCOMDOME2	2.5 Ⓢ	0.2	\$296
 <p>Ⓢ</p>	Under Worksurface Power Module — 4 Outlets, 10' Cord				
	<ul style="list-style-type: none"> Includes 10' cord with three-prong plug. Fits in cable management troughs. 4 outlets on side create easy access. NOTES: Power Modules will also work with standing-height applications for 10500 Series™ and Voi® desks. ⓘ Available in black finish only, no specification needed.	HPWRMOD2	1.5	0.2	\$401
	Vertebrae				
	NOTES: 30"H x 3¼"W x 1½"D. Ships unassembled. ⓘ Clear finish. Specify "X" for finish option. SPECIFYING EXAMPLE: HMPVWM28.X	HMPVWM28	3.0	0.3	\$223

HOW TO SPECIFY

Select Model Number

H P W R M O D 3 W C

CONCINNITY™

Accessories — Paper Organizers

GSA SIN 33721



Icon Legend on page 19

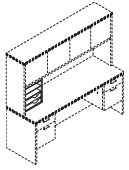

Not available in two-tone laminates

DESCRIPTION

Vertical Paper Manager
14⁷/₈"W x 10⁷/₈"D x 19¹/₈"H

MODEL**HLVPM1****SHIP WEIGHT**

27

CUBE

2.8

L1 LIST PRICE**\$327****L2 UPCHARGE****\$10**

NOTES: Keeps papers, files, and books neatly organized and within easy reach from a seated position. Designed for desk, credenza, and return tops. Fits under stack-on storage models. Two pullout drawers and three fixed shelves. Not available in pattern laminate colors. Ships fully assembled.

ⓘ When used in conjunction with wall mounted storage cabinets, allow 19³/₄" minimum clearance above the worksurface.

SPECIFYING EXAMPLE: HLVPM1.N

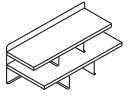

Not available in two-tone laminate

DESCRIPTION

Desktop Storage Terrace
26¹/₂"W x 12¹/₂"D x 10¹/₂"H

MODEL**HLDSTI**

24

1.1

\$306**\$10**

NOTES: Keeps work-in-process, priority files, loose pages, and mail neatly organized and in view. Mixed material design comprised of sturdy laminate shelves with metal back and support panels. Not available in two-tone laminate combination or pattern laminate colors. Choose from Platinum Metallic (T1), Black (P), and Charcoal (S) for the metal components. Designed to be used on worksurfaces. Also sized to fit in stack-on and wall mounted storage cabinets, see compatibility chart on page 111.

Specify: Model.Laminate.Paint

SPECIFYING EXAMPLE: HLDSTI.N.T1

**DESCRIPTION**

Stacked Paper Management
32¹/₂"W x 12⁵/₈"D x 4¹/₄"H

MODEL**HLVPM2****SHIP WEIGHT**

22

CUBE

1.25

LIST PRICE**\$163**

NOTES: Segments and organizes stack-on and wall mount storage compartments (see compatibility chart on page 111), as well as bookcase shelves. In some cases, installation may require removing the stack-on or wall mount storage doors.

ⓘ Black only.

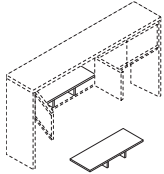
**DESCRIPTION**

Hanging Paper Shelf
28¹/₈"W x 11¹/₈"D x 4⁵/₈"H

MODEL**HHPS1**

7

2.9

\$198

NOTES: Attaches quickly and easily (screws included). Maximizes worksurface space; de-clutters desktop while placing priority communications and active project folders within easy reach. Angled design allows contents to be distinguished at a glance. Mixed material styling features strong painted metal frame with a frosted shelf.

Attaches quickly and easily to laminate stack-on and wall mount storage models (except the 36" W Voi® overhead hutch with O-legs or panel mount brackets). Not for use with 38000 Series™ and Systems.

Specify: Model.Paint

SPECIFYING EXAMPLE: HHPS1.T1

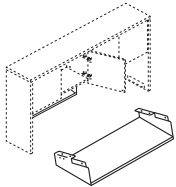
**DESCRIPTION**

Desktop Paper Shelf
28¹/₈"W x 11⁵/₈"D x 5"H

MODEL**HDPS1**

7

2.9

\$198

NOTES: Desktop Paper Shelf and Storage Terrace include protective, non-slip pads on the base. Paper Shelf can stack two-high. Organizer shelf provides a place and space for work-in-process and piling to keep worksurfaces neat and tidy. Convenient, scalable design with interlocking side supports allow two units to be stacked and integrated. Durable painted metal frame with a frosted shelf; mixed material styling matches hanging paper shelf.

Can also be used inside select overhead storage, including the following stack-on with clearance and hinged door models: 10500 and Valido 36", 42", 66", 72", 78"W and 10700 68⁵/₈"W.

Specify: Model.Paint

SPECIFYING EXAMPLE: HDPS1.T1

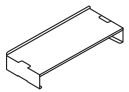
**DESCRIPTION**

Storage Cube
12"W x 12"D

MODEL**HLSL1212**

1

0.3

\$294

SPECIFYING EXAMPLE: HLSL1212.P8S

**HOW TO SPECIFY**

Select
Model Number

H L V P M 1 .

Select
Laminate Color

See page 29

N

CONCINNITY™ PAPER ORGANIZER COMPATIBILITY

PAPER ORGANIZERS FOR STACK-ON AND WALL MOUNTED STORAGE CABINETS

- Laminate vertical paper manager (HLVPM1) is designed for desk, credenza, and return tops; fits under stack-on and wall mount storage units.
- Laminate desktop storage terrace (HLDST1) for use on worksurfaces, or inside overhead storage compartments >26½"W.
- Metal desktop paper shelf (HDPS1) for use on worksurfaces, can be stacked two high, or inside overhead storage compartments >28¾"W.
- Stacked paper management (HLVPM2) can be positioned inside overhead storage cabinets >32½"W.
- Metal hanging paper shelf (HHPS1) attaches quickly and easily to the underside of stack-on and wall mounted storage models.
- For applications using the organizers inside stack-on and wall mounted storage compartments, the fit compatibility is as follows:

OUTSIDE WIDTH	INSIDE WIDTH	Stacked Paper Mgt. — 32½"W HLVPM2	Desktop Paper Shelf — 28¾"W HDPS1	Desktop Storage Terrace — 26½"W HLDST1	Hanging Paper Shelf — 28¾"W HHPS1
		Yes or No	Yes or No	Yes or No	*Qty — see NOTE
STACK-ON STORAGE W/ LAM DOORS, LAM LOCKING DOORS, FROSTED DOORS					
36"W	34.34	Y	Y	Y	1
42"W	40.34	Y	Y	Y	1
48"W (large compartment)	30.60	N	Y	Y	1
60"W	28.60	N	N	Y	2
66"W	31.60	N	Y	Y	2
72"W	34.60	Y	Y	Y	2
78"W	37.60	Y	Y	Y	2
STACK-ON STORAGE W/ SLIDING DOOR					
48"W	22.60	N	N	N	1
60"W	28.60	N	N	Y	2
66"W	31.60	N	Y	Y	2
72"W	34.60	Y	Y	Y	2
78"W	37.60	Y	Y	Y	2
WALL MOUNT STORAGE W/ LAM DOORS, LAM LOCKING DOORS, FROSTED DOORS					
30"W	28.35	N	N	Y	N
36"W	33.67	Y	Y	Y	1
42"W	39.67	Y	Y	Y	1
48"W (large compartment)	30.22	N	Y	Y	1
60"W	28.22	N	N	Y	2
66"W	31.22	N	Y	Y	2
72"W	34.22	Y	Y	Y	2
78"W	37.22	Y	Y	Y	2
WALL MOUNT STORAGE W/ SLIDING DOOR					
48"W	22.46	N	N	N	1
60"W	28.46	N	N	Y	2
66"W	31.46	N	Y	Y	2
72"W	34.46	Y	Y	Y	2
78"W	37.46	Y	Y	Y	2

*NOTE: For model HHPS1, quantity represents the number that can be mounted side-by-side under the cabinet.





CONCINNITY™

Accessories — Lock Kits

GSA SIN 33721 EXCEPT AS NOTED

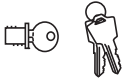

Icon Legend on page 19

	DESCRIPTION	MODEL	SHIP WEIGHT	CUBE	LIST PRICE
	Black Removable Lock Core Kit <ul style="list-style-type: none"> Specify quantity of each key number from 101E-225E. Includes: 1-core, 2-keys, 1-core removal tool, and instructions. NOTES: If key number isn't specified, number will be at random.	HF23B	0.1 	0.1	\$32
	Satin Removable Lock Core Kit <ul style="list-style-type: none"> Specify quantity of each key number from 101E-225E. Includes: 1-core, 2-keys, 1-core removal tool, and instructions. NOTES: If key number isn't specified, number will be at random.	HF23S	0.1 	0.1	\$42
	Removable Lock Core Kit Black Satin	HF27B HF27S	0.2 0.2	0.02 0.02	\$32 \$32
OPEN MARKET	<ul style="list-style-type: none"> For stack-on and wall mounted storage laminate models (with locks) in 10500, 10700, Valido, Voi, Concinnity, and 94000 Series. Specify quantity of each key number from 101E to 225E. Includes: 1-core, 2-keys, 1-core removal tool, and instructions. NOTES: If key number isn't specified, number will be at random.				

NOTES:

- Interchangeable core removable locks are standard on most HON products.
- Removable lock core kits with specific key number must be ordered to facilitate keying alike in the field.
- For keyed alike locks:
 - Order standard product which will be shipped with factory installed locks and random numbered cores.
 - Order the appropriate quantity of like numbered cores required for each workstation or keyed area.
 - Simply replace the factory installed cores with the replacement cores after product has been installed.
- To install new core:
 - Lock must be in the unlocked position.
 - Insert core removal key and pull core straight out.
 - Insert new core with core removable key, hold core into lock and withdraw core removal key.
 - Retain original core for future use.
- For master key, see model HF22 on page 746.
- To provide normal lead times, key numbers cannot be specified on HON products at time of order. This also eliminates need for tagging and tracking each product's lock number during installation.

HOW TO ORDER CORE REMOVABLE LOCK KITS:

Specify: Model Number.X
Key Number

Examples: HF23S.X121E
HF23S.X (Key number not specified)

NOTES: Key orders without numbers specified will be keyed at random.
Numbers 101E-225E are available.

SAMPLE ORDER:

Quantity	Model	Key Code
4	HF23B.	X121E

HOW TO SPECIFY

Select
Model Number

H F 2 3 B



CONCINNITY™

Accessories — Task Lights

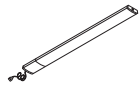

OPEN MARKET

DESCRIPTION**MODEL****SHIP WEIGHT****CUBE****LIST PRICE****LED Task Lights — For Stack-on and Wall Mounted Storage Cabinets**

17" LED Light with Power Supply (Single)

HLED17AS ☉

1.2

0.05

\$420

31" LED Light with Power Supply (Single)

HLED31AS ☉

1.5

0.09

\$564

17" LED Light with Power Supply for Daisy-chain (Starter)

HLED17A

1.0

0.05

\$461

31" LED Light with Power Supply for Daisy-chain (Starter)

HLED31A

1.4

0.09

\$619

17" LED Light with 8" Jumper Cord for Daisy-chain (Follower)

HLED17AUO ☉

1.0

0.03

\$377

31" LED Light with 8" Jumper Cord for Daisy-chain (Follower)

HLED31AUO ☉

1.0

0.05

\$503**Undercabinet Occupancy Sensor with 1" End to End Connector****HLEDOSA** ☉

0.2

0.01

\$89

NOTES: To use the daisy chain application, must start with model HLED17A or HLED31A. No finish specification required. Attaches magnetically to underside of overhead storage, or attaches with provided screws or double-sided tape. Occupancy sensor attaches to a single or starter LED light and will automatically turn the light off after no motion is detected for 30 minutes. Just like all the LED light models, the occupancy sensor features a soft-touch on/off switch. LED task lights have a lifetime of 50,000 hours and have a dimmer feature that allows the user to adjust the amount of light output.

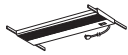

OPEN MARKET

Recessed Task Lights — For Stack-on and Wall Mounted Storage Cabinets

- Color: Black.
- Slim profile design.
- Mount to stack-on storage and wall mounted storage cabinets (see pages 55-59 and 62-65).
- Electronic ballast for increased energy efficiency.
- T5 bulb, included, which contains less mercury.
- 9-foot black cord and switch off right rear corner.

22⁷/₈"W x 3¹/₁₆"D x 1¹/₈"H

Chicago code version (with fused plug)

HH870930

7.0

0.60

\$23134⁵/₈"W x 3¹/₁₆"D x 1¹/₈"H

Chicago code version (with fused plug)

HH870930CH

7.0

0.60

\$301**HH870942**

10.0

0.90

\$250

Chicago code version (with fused plug)

HH870942CH

10.0

0.90

\$31746¹/₂"W x 3¹/₁₆"D x 1¹/₈"H

Chicago code version (with fused plug)

HH870960

12.0

1.10

\$270**HH870960CH**

12.0

1.10

\$337

SIN 33721

Articulating Desk Lamp**HLED1**

1.2

6.5

\$402**Articulating Desk Lamp w/ Occupancy Sensor****HLED1OC**

1.2

6.5

\$490

SIN 33721

Task Desk Lamp**HLED2**

0.7

3.0

\$348**HOW TO SPECIFY**Select
Model Number

H H 8 7 0 9 3 0

CONCINNITY™

Accessories

OPEN MARKET EXCEPT AS NOTED



Icon Legend on page 19



Refer to the Workplace Tools section in the 2021 Shared Spaces Pricer for additional product information

SIN 33721



DESCRIPTION	MODEL	SHIP WEIGHT	CUBE	LIST PRICE BY PAINT GRADE	
				P1	P2
Slide-Away Keyboard Platform (Specify: Laminate)	H4022	10	0.6	\$213	
Extended Tray Slide-Away Keyboard Platform (Specify: Laminate)	HE4022	12	0.7	\$302	
Metal Keyboard and Mouse Tray (Specify paint)	H4028 OPEN MARKET	11	1.5	\$153	\$163
Metal Keyboard Tray (Specify paint)	H4029 OPEN MARKET	11	1.5	\$138	\$148

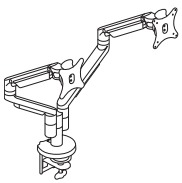

DESCRIPTION	MODEL	SHIP WEIGHT	CUBE	LIST PRICE
Dual Dynamic Monitor Arm <ul style="list-style-type: none"> • 150° of rotation at base with optional 360° rotation. • Arms extend 22" and retract up to 3". • Monitor mount rotates 180° and tilts +/-30°. • Monitor can be rotated from landscape to portrait position. <p>! Arms hold monitors from 6.2-18 lbs. Optional counterweight HPACW available to support monitors as low as 5 lbs. (see the Workplace Tools section in the 2021 Shared Spaces Pricer).</p>	HMASD	17.0	1.1	\$900

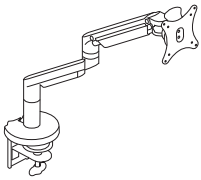

Single Dynamic Monitor Arm <ul style="list-style-type: none"> • 180° of rotation at base with optional 360° rotation. • Arms extend 22" and retract up to 3". • Monitor mount rotates 180° and tilts +/-30°. • Monitor can be rotated from landscape to portrait position. <p>! Arms hold monitors from 6.2-18 lbs. Optional counterweight HPACW available to support monitors as low as 5 lbs. (see the Workplace Tools section in the 2021 Shared Spaces Pricer).</p>	HMASTS	11.5	0.8	\$468
--	---------------	------	-----	--------------

NOTES:**Monitor Arms Only**

- Arms fold back to post to allow more desktop room.
- Arms feature double extension, allowing 20"+ of back and forth movement.
- Cable management on both pole and arm assemblies.
- Counterbalance adjustment provides stability for monitors up to 17 lbs per arm.
- Made of high quality aluminum alloy material.
- See the Workplace Tools section in the 2021 Shared Spaces Pricer for additional monitor arm models.

HOW TO SPECIFY**Select Model Number****Select Finish**

Specify for models HMASD and HMASTS only

SVR Silver
BLK Black

HMASD.

SVR

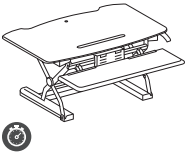
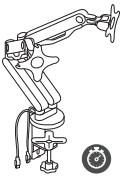
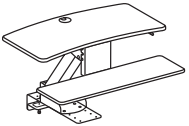
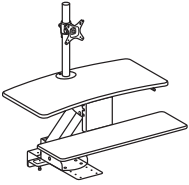
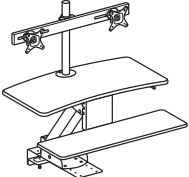

	DESCRIPTION	MODEL	SHIP WEIGHT	CUBE	LIST PRICE
	Coordinate™ Portable Desktop Riser 31"D x 5"-16½"H x 35"W NOTES: Available in Black (BLK) or White (WHT) finish. Desktop riser dimensions (without keyboard tray): 22"D x 5"-16½"H x 35"W. Keyboard tray dimensions: 9"D x 30"W. Max loading capacity is 33 lbs for the desktop riser surface and 4 lbs for the keyboard tray. Easily transition from seated to standing positions throughout the workday. Sits atop an existing desk to create sit-to-stand functionality by raising the computer. Includes keyboard tray and surface for computer monitors. HON 5-Year Limited Warranty. ⓘ Not intended for use on mobile workstations.	HBXRISER	54.0	4.1	\$619
	Dual Monitor Arm with 2 USB Ports NOTES: Easy adjustment. Height adjusts to 17" tall. Monitor tilt and swivel capability. Enclosed cable management. Grommet or desktop mounting. Clean appearance. In some applications the Monitor Arms may extend 12 or more inches into the worksurface. HON 5-Year Limited Warranty. ⓘ No specification needed.	HBDMAUSB	41.9	2.6	\$383
	Coordinate™ Mounted Desktop Riser NOTES: Does not include a monitor arm and is suitable for laptops and/or monitors on their original stands. ⓘ No specification needed.	HS1100	60.0 ⓘ	3.2	\$664
	Coordinate™ Mounted Desktop Riser with Single Monitor Arm NOTES: Includes a monitor arm for a single monitor. ⓘ No specification needed.	HS1101	62.0 ⓘ	3.2	\$777
	Coordinate™ Mounted Desktop Riser with Dual Monitor Arm NOTES: Includes a monitor arm for dual monitors. ⓘ No specification needed.	HS1102	63.0 ⓘ	3.2	\$883

NOTES FOR HS1100, HS1101, HS1102:

- These products are designed to allow the user to transition from seating position to standing position throughout the workday.
- Gas-assist lever-operated mechanism with positive stop.
- Clamp mount compatible with worksurfaces depths of 20"-30". 20" is for systems only.
- Clamp requires 3.5" of clearance along back edge of worksurface.
- Black seamless worksurfaces.
- Silver powder coated metal components.
- Lowers below worksurface level on 24" and 30"D worksurfaces.
- All models contain a large primary worksurface and a smaller keyboard / mouse surface.
- Beveled edges for sleek appearance and comfort while typing.
- Monitor arms include height, width, and swivel adjustment.

- Not for use under overhead storage, with flush mounted modesty panels, or worksurfaces thinner than 1".

ⓘ Not recommended for use on mobile (castered) worksurfaces.

MOUNTING AND COMPATIBILITY FOR HS1100, HS1101, HS1102:

- This product is intended to be installed on commercial-grade worksurfaces in good condition.
- Compatible with freestanding worksurfaces 24"-30"D or panel-supported worksurfaces 24"-30"D.
- Not for use on mobile worksurfaces.

Clamp Mount

Use when 3.5" minimum overhang is available

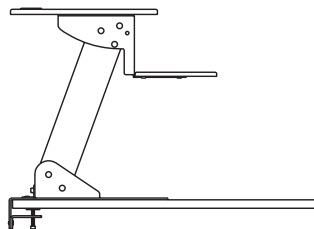

Screw Mount

Use when no overhang is available. Worksurface must be minimum 1" thick.

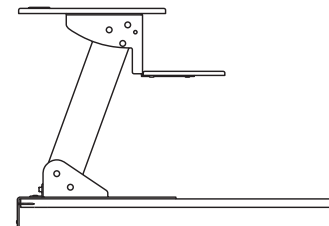

HOW TO SPECIFY

<p>Select Model Number</p> <p>HBXRISER.</p>	<p>Select Finish</p> <p>BLK Black WHT White</p> <p>BLK</p>
---	--



CONCINNITY™

Accessories

OPEN MARKET

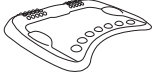
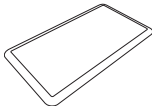
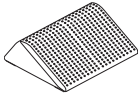

Icon Legend on page 19

	DESCRIPTION	MODEL	SHIP WEIGHT	CUBE	LIST PRICE
	Rectangle Wobble Board — Anti-Fatigue Mat 18"D x 3"H x 22½"W ⓘ Available in Black (T) finish ONLY. Recommended weight capacity not to exceed 250 pounds. HON 5-Year Limited Warranty. SPECIFYING EXAMPLE: HVL981.T	HVL981 ⓘ	10.0 Ⓢ	0.9	\$121
	Round Wobble Board — Anti-Fatigue Mat 18½"D x 2½"H x 18½"W ⓘ Available in Black (T) finish ONLY. Recommended weight capacity not to exceed 250 pounds. HON 5-Year Limited Warranty. SPECIFYING EXAMPLE: HVL982.T	HVL982 ⓘ	5.8 Ⓢ	0.6	\$103
	Ergonomic Anti-Fatigue Mat 25"D x 2¾"H x 29⅞"W ⓘ Available in Black ONLY. No specification needed. SPECIFYING EXAMPLE: HBEAFM1	HBEAFM1	7.0	1.4	\$219
	Rectangle Anti-Fatigue Mat 20"D x ¾"H x 36"W ⓘ Available in Black ONLY. No specification needed. SPECIFYING EXAMPLE: HBAFM2036	HBAFM2036 ⓘ	5.4	0.4	\$100
	Footrest — Anti-Slip Cover 13¾"D x 5½"H x 16"W ⓘ Available in Black (T) finish ONLY. Recommended weight capacity not to exceed 250 pounds. HON 5-Year Limited Warranty. SPECIFYING EXAMPLE: HVL991.T	HVL991	7.0 Ⓢ	0.9	\$82

NOTES:

ⓘ Discontinued 1/1/21.

HOW TO SPECIFY

Select Model Number H V L 9 8 1 .	Select Finish T Black
---	---------------------------------



Coze™ Table Desk with Solve® Seating.

COZE™

There's no place like home, especially when you're working. Stay as productive in your own digs as you are in the office with Coze table desks. Designed to keep things nice and easy, Coze features simple and quick assembly and optional fast shipping so you can get down to business in no time. Not too big and not too small, Coze comes in three sizes, so it's just right for whatever space you're working in. With optional built-in storage to help you stay organized and a clean, light-scale look in a variety of laminate and finish colors, Coze feels right at home no matter your personal style.



FEATURES

- Enjoy a higher quality desk at a lower price.
- Simple one-tool installation with video takes only minutes.
- Light scale design and small footprint fit any room in the house.
- Optional integrated storage lets you decide how to best stay organized.
- Available in a variety of laminate and paint colors so you can get exactly what you need in the look you want.
- Leveling glides adjust for uneven floors.
- Durable laminate surfaces resist scratches, spills, and stains.

COZE™ Table Desks

OPEN MARKET



Icon Legend on page 19

	DESCRIPTION	MODEL	SHIP WEIGHT	CUBE	LIST PRICE
	Table Desk with Post Legs				
	54"W x 24"D	HLCRPL5424WFH	71	5.7	\$530
	48"W x 24"D	HLCRPL4824WFH	66	5.4	\$505
	42"W x 24"D	HLCRPL4224WFH	61	5.2	\$480
	54"W x 30"D	HLCRPL5430WFH	81	6.3	\$605
	48"W x 30"D	HLCRPL4830WFH	76	5.9	\$585
NOTES: Product ships with desk top and 4 legs in 2 cartons.					
	Table Desk with Post Legs and U-Storage				
	54"W x 24"D	HLCRPL5424WFH-US	78	5.7	\$585
	48"W x 24"D	HLCRPL4824WFH-US	73	5.4	\$560
	42"W x 24"D	HLCRPL4224WFH-US	68	5.2	\$535
	54"W x 30"D	HLCRPL5430WFH-US	88	6.3	\$660
	48"W x 30"D	HLCRPL4830WFH-US	83	5.9	\$640
NOTES: Product ships with desk top, 4 legs, and U-storage in 2 cartons.					
	Table Desk with Post Legs and Pencil Storage				
	54"W x 24"D	HLCRPL5424WFH-PS	77	5.7	\$585
	48"W x 24"D	HLCRPL4824WFH-PS	72	5.4	\$560
	42"W x 24"D	HLCRPL4224WFH-PS	67	5.2	\$535
	54"W x 30"D	HLCRPL5430WFH-PS	87	6.3	\$660
	48"W x 30"D	HLCRPL4830WFH-PS	82	5.9	\$640
NOTES: Product ships with desk top, 4 legs, and pencil storage in 2 cartons.					

NOTES:

- HON 5-Year Limited Warranty.

HOW TO SPECIFY

Select Model Number H L C R P L 4 8 2 4 W F H - U S	Select Laminate and Edge PP Black LDW1DW Designer White LFW1FW Florence Walnut LNR1NR Natural Recon	Select Paint Color P71 Black PJW Designer White PR6 Silver
---	--	--

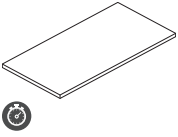
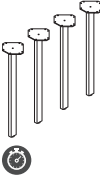
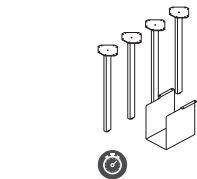
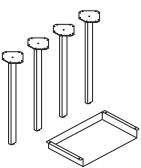
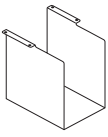
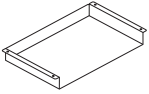

	DESCRIPTION	MODEL	SHIP WEIGHT	CUBE	LIST PRICE
	Coze Rectangle Worksurface				
	42"W x 24"D	HLCR2442WFH	35	2.1	\$250
	48"W x 24"D	HLCR2448WFH	40	2.4	\$275
	54"W x 24"D	HLCR2454WFH	45	2.7	\$300
	48"W x 30"D	HLCR3048WFH	50	2.9	\$355
	54"W x 30"D	HLCR3054WFH	55	3.3	\$375
NOTES: Compatible with Coordinate™ Height Adjustable Base model HHABETA2S2L with pre-drilled pilot holes. Worksurfaces come with threaded inserts for ease of installation with Post Legs models HLCPL29WFH, HLCPL29WFH-US, and HLCPL29WFH-PS.					
	Post Legs, Pack of 4	HLCPL29WFH	26	3.0	\$230
	Post Legs, Pack of 4 with U-Storage	HLCPL29WFH-US	33	3.0	\$285
	NOTES: Metal storage ships same color as legs.				
	Post Legs, Pack of 4 with Pencil Storage	HLCPL29WFH-PS	32	3.0	\$285
	NOTES: Metal storage ships same color as legs. ! Hardware included is specific to the attachment of the following models: HLCR2442WFH, HLCR2448WFH, HLCR2454WFH.				
	U-Storage	HLCWFH-US	9	1.2	\$140
	Pencil Storage	HLCWFH-PS	8	1.2	\$140
	! Hardware included is specific to the attachment of the following models: HLCR2442WFH, HLCR2448WFH, HLCR2454WFH.				

NOTES:
 • HON 5-Year Limited Warranty.

HOW TO SPECIFY

<p>Select Model Number</p> <p>H L C R 2 4 4 8 W F H .</p>	<p>Select Laminate and Edge</p> <p>PP Black LDW1DW Designer White LFW1FW Florence Walnut LNR1NR Natural Recon</p> <p>L F W 1 F W</p>
<p>Select Model Number</p> <p>H L C P L 2 9 W F H - P S .</p>	<p>Select Paint Color</p> <p>P71 Black PJW Designer White PR6 Silver</p> <p>P R 6</p>

MOD



Mod Desks shown with Coordinate™ Height Adjustable Tables and Solve® Seating.

MOD

There is always beauty in simplicity, but with the Mod desk collection you'll also find variety and value. The contemporary design feels perfectly at home in either a private office or an open floor plan, giving it the versatility that allows you to unify your space. Choose from a selection of finishes that express your modern sense of style, or dress it up with a classic look. Whether setting up a single desk, shared workstations, or full private office suite with storage, this collection is totally adaptable. Totally productive. Totally Mod.



FEATURES

- The Mod collection allows you to create a premium workspace at an affordable price.
- Straightforward styling blends with any office design with the option for metal A- and U-legs.
- Available in 6 laminate finishes.
- Storage options that let you create spaces that work the way you do.
- All components feature a scratch- and stain-resistant laminate for unbeatable beauty and durability.

MOD ORDERING INFORMATION

LAMINATES

L1 LAMINATES CODES

Woodgrain

- ◆ Java Oak LJA1
- ◆ Russet Cherry LRC1
- ◆ Sepia Walnut LSE1
- ◆ Slate Teak LSL1
- ◆ Traditional Mahogany LTM1

Solid

- ◆ Simply White LPW1

METAL A-LEGS, U-LEGS, AND SUPPORT LEGS

PAINTS CODES

- ◆ Black BLKP
- ◆ Silver SLVR

FABRIC CUSHIONS & TACKBOARDS

FABRIC CODES

- ◆ Cool Neutral CN02
- ◆ Warm Neutral WM01

◆◆◆ For lead time information see page 19.

MOD LAMINATE GRAIN DIRECTION

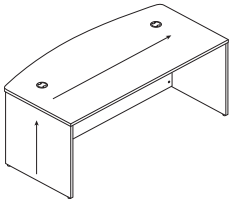

Bow Top Desk Shell

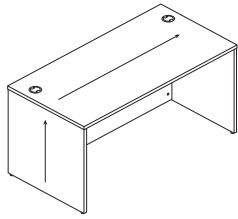

Rectangle Desk Shell

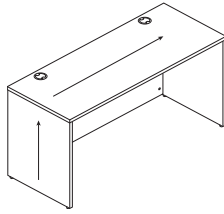

Rectangle Credenza Shell

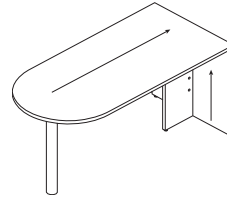

Peninsula

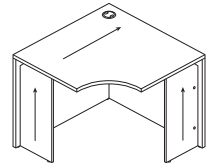

Corner Shell

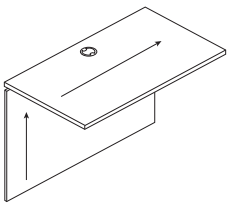

Bridge

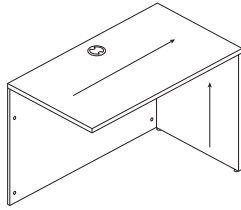

Return

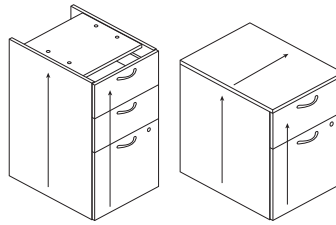

Pedestals

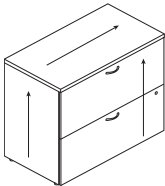

Laterals

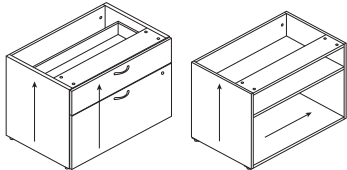

Low Credenzas

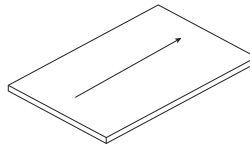

Low Credenza Top



Wardrobe

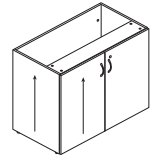

Storage Cabinet

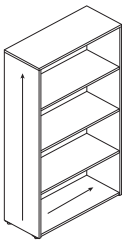

Bookcase

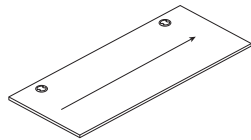

Rectangle Worksurface

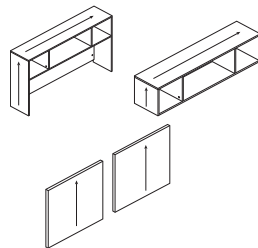

Overhead Hutch, Storage, and Laminate Doors

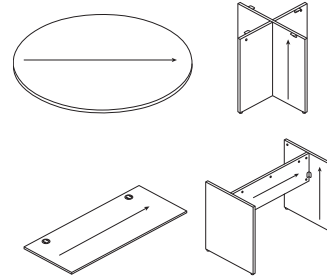

Conference Table Tops and Bases

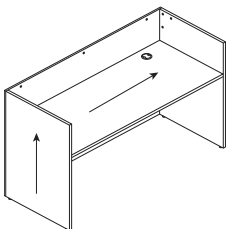

Reception Desk and Transaction Top

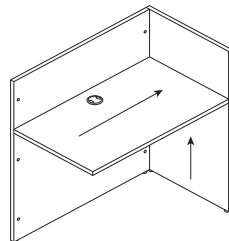
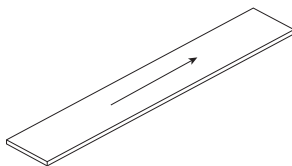

Reception Return Shell

Components used are listed on pages 130-138. Order components individually. Other configurations are possible, including various sizes of some components.

QTY	DESCRIPTION	MODEL	LIST PRICE	PRICE EXTENSION
1	Desk Shell 66"W x 30"D	HLPLDS6630	\$279	\$279
1	Credenza Shell 66"W x 24"D	HLPLCS6624	\$260	\$260
1	Bridge 42"W x 24"D	HLPLB4224	\$159	\$159
1	Pedestal - B/B/F 15"W x 20"D x 28"H	HLPLPSBBF	\$311	\$311
1	Pedestal - F/F 15"W x 20"D x 28"H	HLPLPSFF	\$311	\$311
1	Hutch without Doors 66"W x 14"D x 39¾"H	HLPLDH66	\$301	\$301
2	Laminate Hutch Doors Pack of 2 Doors	HLPLDR66LM	\$36	\$72
TOTAL:			\$1,693	

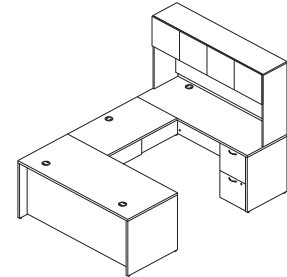

U-STATION (NON-HANDED)
66"W x 96"D

QTY	DESCRIPTION	MODEL	LIST PRICE	PRICE EXTENSION
1	Peninsula 66"W x 30"D	HLPLPEN6630	\$288	\$288
1	Credenza Shell 66"W x 24"D	HLPLCS6624	\$260	\$260
1	Bridge 42"W x 24"D	HLPLB4224	\$159	\$159
1	Pedestal - B/B/F 15"W x 20"D x 28"H	HLPLPSBBF	\$311	\$311
1	Hutch without Doors 66"W x 14"D x 39¾"H	HLPLDH66	\$301	\$301
1	Laminate Hutch Doors Pack of 2 Doors	HLPLDR66LM	\$36	\$36
TOTAL:			\$1,355	

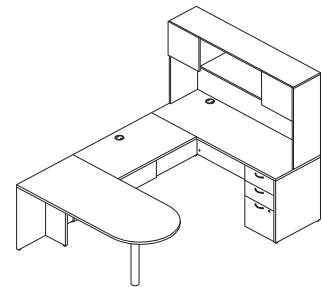

U-STATION WITH PENINSULA (NON-HANDED)
66"W x 96"D

QTY	DESCRIPTION	MODEL	LIST PRICE	PRICE EXTENSION
1	Desk Shell 66"W x 30"D	HLPLDS6630	\$279	\$279
1	Return Shell 42"W x 24"D	HLPLRS4224	\$189	\$189
1	Pedestal - B/B/F 15"W x 20"D x 28"H	HLPLPSBBF	\$311	\$311
1	Pedestal - F/F 15"W x 20"D x 28"H	HLPLPSFF	\$311	\$311
1	Hutch without Doors 66"W x 14"D x 39¾"H	HLPLDH66	\$301	\$301
2	Glass Hutch Doors Pack of 2 Doors	HLPLDR66GS	\$131	\$262
TOTAL:			\$1,653	

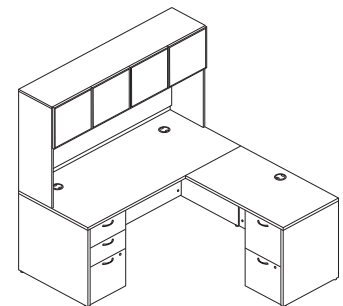

L-STATION (NON-HANDED)
66"W x 72"D

MOD Typicals

Components used are listed on pages 130-138. Order components individually. Other configurations are possible, including various sizes of some components.

QTY	DESCRIPTION	MODEL	LIST PRICE	PRICE EXTENSION
1	Bow Front Desk Shell 72"W x 36"D	HLPLDS7236B	\$353	\$353
1	Credenza Shell 72"W x 24"D	HLPLCS7224	\$270	\$270
1	Pedestal - B/B/F 15"W x 20"D x 28"H	HLPLPSBBF	\$311	\$311
1	Pedestal - F/F 15"W x 20"D x 28"H	HLPLPSFF	\$311	\$311
1	Hutch without Doors 66"W x 14"D x 39 ³ / ₄ "H	HLPLDH66	\$301	\$301
2	Laminate Hutch Doors Pack of 2 Doors	HLPLDR66LM	\$36	\$72
TOTAL:				\$1,618

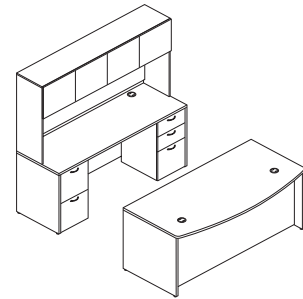

OFFICE SUITE
72"W x 96"D

QTY	DESCRIPTION	MODEL	LIST PRICE	PRICE EXTENSION
1	Reception Desk Shell 72"W x 30"D	HLPLRCPNDS7230	\$406	\$406
1	Reception Return Shell 42"W x 25"D	HLPLRCPNRS4225	\$245	\$245
1	Reception Laminate Transaction Top 72"W x 12"D	HLPLRCPNTPLM	\$86	\$86
1	Pedestal - B/B/F 15"W x 20"D x 28"H	HLPLPSBBF	\$311	\$311
TOTAL:				\$1,048

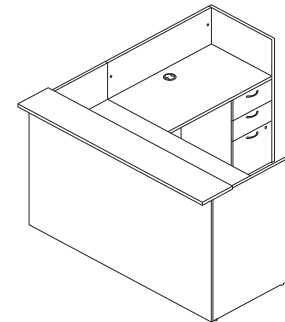

**RECEPTION STATION
(NON-HANDED)**
72"W x 72"D

QTY	DESCRIPTION	MODEL	LIST PRICE	PRICE EXTENSION
1	Rectangle Conference Table Top 48"W x 120"L, 2-Piece	HLPLTBL4812ORCT	\$658	\$658
1	Conference Table Base For 120" Table Tops	HLPLTBL120BASE	\$105	\$105
2	Wardrobe 24"W x 24"D x 65"H	HLPLW2424	\$796	\$1,592
2	Low Open Storage Credenza 36"W x 20"D x 21"H	HLPLCL3620S	\$243	\$486
1	Low Credenza Top 72"W x 20"D	HLPLCL7220TOP	\$127	\$127
TOTAL:				\$2,968

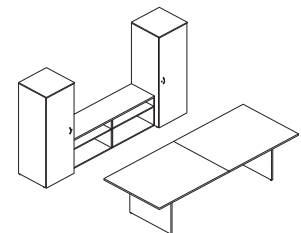

CONFERENCE ROOM
144"W x 180"D

Components used are listed on pages 130-138. Order components individually. Other configurations are possible, including various sizes of some components.

QTY	DESCRIPTION	MODEL	LIST PRICE	PRICE EXTENSION
1	Rectangle Worksurface 66"W x 30"D	HLPLRW6630	\$179	\$179
1	Rectangle Worksurface 48"W x 24"D	HLPLRW4824	\$135	\$135
1	Flat Bracket 24"D	HLPLFB24	\$45	\$45
2	U-Leg Support 30"W	HLPLLEG30U	\$144	\$288
1	U-Leg Support 24"W	HLPLLEG24U	\$135	\$135
1	External Stiffener For 66"W Worksurfaces	HLPLXS66	\$70	\$70
1	Mobile Pedestal - B/F 15"W x 20"D x 20"H	HLPLPMBF	\$272	\$272
1	Pedestal Cushion 15"W x 20"D	HLPLPSEAT1520	\$86	\$86
TOTAL:			\$1,210	

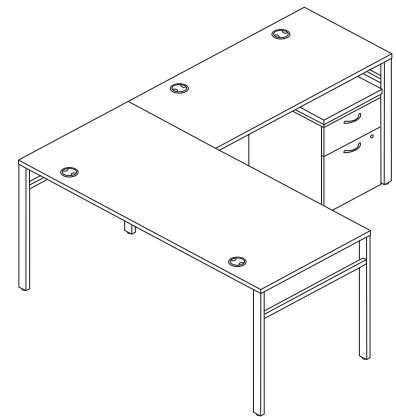

L-STATION (NON-HANDED)
66"W x 78"D

QTY	DESCRIPTION	MODEL	LIST PRICE	PRICE EXTENSION
1	Rectangle Worksurface 66"W x 30"D	HLPLRW6630	\$179	\$179
1	U-Leg Support 30"W	HLPLLEG30U	\$144	\$144
1	External Stiffener For 66"W Worksurfaces	HLPLXS66	\$70	\$70
1	Credenza Leg Support 7"H x 30"D	HLPLSL30	\$94	\$94
1	Low 2-Drawer Credenza 30"W x 20"D x 21"H	HLPLCL3020BF	\$505	\$505
1	Low Open Storage Credenza 30"W x 20"D x 21"H	HLPLCL3020S	\$232	\$232
1	Low Credenza Top 60"W x 20"D	HLPLCL6020TOP	\$116	\$116
TOTAL:			\$1,340	

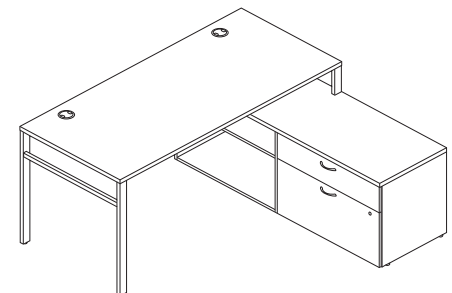

**L-STATION WITH CREDENZA
(NON-HANDED)**
66"W x 60"D

MOD

Bundles Typical

Traditional Mahogany
HLPLDS72PSTM1

Sepia Walnut
HLPLDS72PSSE1

Java Oak
HLPLDS72PSJA1

Russet Cherry
HLPLDS72PSRC1

Slate Teak
HLPLDS72PSSL1

QTY	DESCRIPTION	MODEL	LIST PRICE	PRICE EXTENSION
1	Rectangular Desk Shell	HLPLDS7230	\$295	\$295
1	B/B/F Support Pedestal	HLPLPSBBF	\$311	\$311
1	F/F Support Pedestal	HLPLPSFF	\$311	\$311
TOTAL:			\$917	

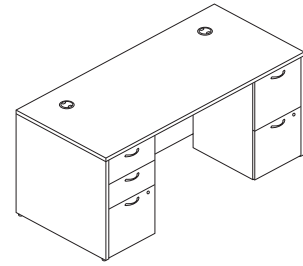

LAMINATE DESK WITH 2 PEDESTALS
72"W

Traditional Mahogany
HLPLDS66PSTM1

Sepia Walnut
HLPLDS66PSSE1

Java Oak
HLPLDS66PSJA1

Russet Cherry
HLPLDS66PSRC1

Slate Teak
HLPLDS66PSSL1

QTY	DESCRIPTION	MODEL	LIST PRICE	PRICE EXTENSION
1	Rectangular Desk Shell	HLPLDS6630	\$279	\$279
1	B/B/F Support Pedestal	HLPLPSBBF	\$311	\$311
1	F/F Support Pedestal	HLPLPSFF	\$311	\$311
TOTAL:			\$901	

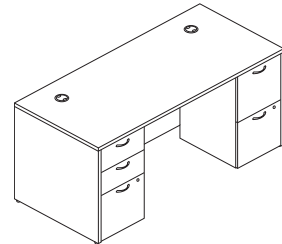

LAMINATE DESK WITH 2 PEDESTALS
66"W

Traditional Mahogany
HLPLDS60PSTM1

Sepia Walnut
HLPLDS60PSSE1

Java Oak
HLPLDS60PSJA1

Russet Cherry
HLPLDS60PSRC1

Slate Teak
HLPLDS60PSSL1

QTY	DESCRIPTION	MODEL	LIST PRICE	PRICE EXTENSION
1	Rectangular Desk Shell	HLPLDS6030	\$255	\$255
1	B/B/F Support Pedestal	HLPLPSBBF	\$311	\$311
TOTAL:			\$566	

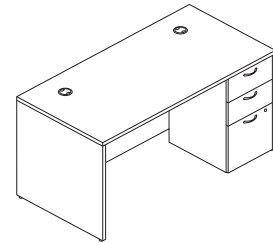

LAMINATE DESK WITH 1 PEDESTAL
60"W

Traditional Mahogany
HLPLDS48HBFM1

Sepia Walnut
HLPLDS48HBFSE1

Java Oak
HLPLDS48HBFJA1

Russet Cherry
HLPLDS48HBFRC1

Slate Teak
HLPLDS48HBFSL1

QTY	DESCRIPTION	MODEL	LIST PRICE	PRICE EXTENSION
1	Rectangular Desk Shell	HLPLDS4830	\$245	\$245
1	B/F Hanging Pedestal	HLPLPHBF	\$228	\$228
TOTAL:			\$473	

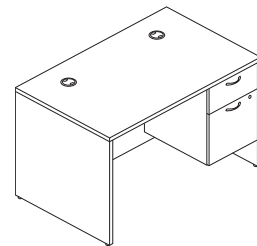

SMALL OFFICE DESK WITH 3/4 PEDESTAL
48"W

MOD Bundles Typicals

Black/Traditional Mahogany
HLPLW60LEG30UBLKPTM1

Black/Russet Cherry
HLPLW60LEG30UBLKPRC1

Black/Java Oak
HLPLW60LEG30UBLKPPJA1

Black/Sepia Walnut
HLPLW60LEG30UBLKPSE1

Black/Slate Teak
HLPLW60LEG30UBLKPSL1

Black/Simply White
HLPLW60LEG30UBLKPPW1

Silver/Traditional Mahogany
HLPLW60LEG30USLVRTM1

Silver/Russet Cherry
HLPLW60LEG30USLVRR1

Silver/Java Oak
HLPLW60LEG30USLVRJA1

Silver/Sepia Walnut
HLPLW60LEG30USLVRSE1

Silver/Slate Teak
HLPLW60LEG30USLVRSL1

Silver/Simply White
HLPLW60LEG30USLVRPW1

QTY	DESCRIPTION	MODEL	LIST PRICE	PRICE EXTENSION
1	Rectangular Worksurface	HLPLRW6030	\$169	\$169
1	External Stiffener	HLPLXS60	\$65	\$65
2	U-Leg Support 30"W	HPLLEG30U	\$144	\$288
TOTAL:			\$522	

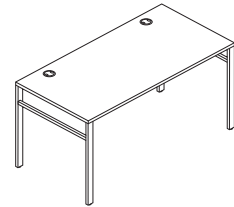

TABLE DESK WITH U-LEG
60"W x 30"D

Black/Traditional Mahogany
HLPLW66LEG30UBLKPTM1

Black/Russet Cherry
HLPLW66LEG30UBLKPRC1

Black/Java Oak
HLPLW66LEG30UBLKPPJA1

Black/Sepia Walnut
HLPLW66LEG30UBLKPSE1

Black/Slate Teak
HLPLW66LEG30UBLKPSL1

Black/Simply White
HLPLW66LEG30UBLKPPW1

Silver/Traditional Mahogany
HLPLW66LEG30USLVRTM1

Silver/Russet Cherry
HLPLW66LEG30USLVRR1

Silver/Java Oak
HLPLW66LEG30USLVRJA1

Silver/Sepia Walnut
HLPLW66LEG30USLVRSE1

Silver/Slate Teak
HLPLW66LEG30USLVRSL1

Silver/Simply White
HLPLW66LEG30USLVRPW1

QTY	DESCRIPTION	MODEL	LIST PRICE	PRICE EXTENSION
1	Rectangular Worksurface	HLPLRW6630	\$179	\$179
1	External Stiffener	HLPLXS66	\$70	\$70
2	U-Leg Support 30"W	HPLLEG30U	\$144	\$288
TOTAL:			\$537	

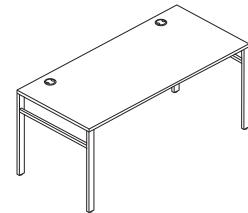

TABLE DESK WITH U-LEG
66"W x 30"D

Nickel/Traditional Mahogany
HLPLRW7224HATTM1

Nickel/Russet Cherry
HLPLRW7224HATRC1

Nickel/Java Oak
HLPLRW7224HATJA1

Nickel/Sepia Walnut
HLPLRW7224HATSE1

Nickel/Slate Teak
HLPLRW7224HATSL1

Nickel/Simply White
HLPLRW7224HATPW1

QTY	DESCRIPTION	MODEL	LIST PRICE	PRICE EXTENSION
1	Height Adjustable Base, 2-Stage	HHAB2S2L	\$1,006	\$1,006
1	Rectangular Worksurface	HLPLRW7224	\$157	\$157
TOTAL:			\$1,163	

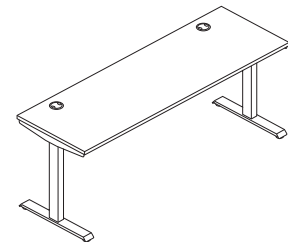

2-STAGE HEIGHT ADJUSTABLE TABLE
72"W x 24"D

MOD Bundles Typicals

Nickel/Traditional Mahogany
HLPLRW7230HATTM1

Nickel/Sepia Walnut
HLPLRW7230HATSE1

Nickel/Russet Cherry
HLPLRW7230HATRC1

Nickel/Slate Teak
HLPLRW7230HATSL1

Nickel/Java Oak
HLPLRW7230HATJA1

Nickel/Simply White
HLPLRW7230HATPW1

QTY	DESCRIPTION	MODEL	LIST PRICE	PRICE EXTENSION
1	Height Adjustable Base, 2-Stage	HHAB2S2L	\$1,006	\$1,006
1	Rectangular Worksurface	HLPLRW7230	\$191	\$191
TOTAL:				\$1,197

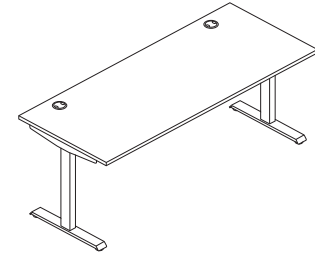

2-STAGE HEIGHT ADJUSTABLE TABLE

72" W x 30" D

Nickel/Traditional Mahogany
HLPLRW6024HATTM1

Nickel/Sepia Walnut
HLPLRW6024HATSE1

Nickel/Russet Cherry
HLPLRW6024HATRC1

Nickel/Slate Teak
HLPLRW6024HATSL1

Nickel/Java Oak
HLPLRW6024HATJA1

Nickel/Simply White
HLPLRW6024HATPW1

QTY	DESCRIPTION	MODEL	LIST PRICE	PRICE EXTENSION
1	Height Adjustable Base, 2-Stage	HHAB2S2L	\$1,006	\$1,006
1	Rectangular Worksurface	HLPLRW6024	\$139	\$139
TOTAL:				\$1,145

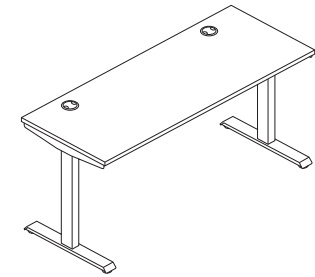

2-STAGE HEIGHT ADJUSTABLE TABLE

60" W x 24" D

Nickel/Traditional Mahogany
HLPLRW6030HATTM1

Nickel/Sepia Walnut
HLPLRW6030HATSE1

Nickel/Russet Cherry
HLPLRW6030HATRC1

Nickel/Slate Teak
HLPLRW6030HATSL1

Nickel/Java Oak
HLPLRW6030HATJA1

Nickel/Simply White
HLPLRW6030HATPW1

QTY	DESCRIPTION	MODEL	LIST PRICE	PRICE EXTENSION
1	Height Adjustable Base, 2-Stage	HHAB2S2L	\$1,006	\$1,006
1	Rectangular Worksurface	HLPLRW6030	\$169	\$169
TOTAL:				\$1,175

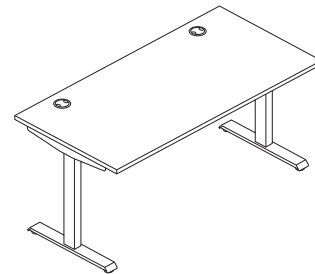

2-STAGE HEIGHT ADJUSTABLE TABLE

60" W x 30" D

Nickel/Traditional Mahogany
HLPLRW4824HATTM1

Nickel/Sepia Walnut
HLPLRW4824HATSE1

Nickel/Russet Cherry
HLPLRW4824HATRC1

Nickel/Slate Teak
HLPLRW4824HATSL1

Nickel/Java Oak
HLPLRW4824HATJA1

Nickel/Simply White
HLPLRW4824HATPW1

QTY	DESCRIPTION	MODEL	LIST PRICE	PRICE EXTENSION
1	Height Adjustable Base, 2-Stage	HHAB2S2L	\$1,006	\$1,006
1	Rectangular Worksurface	HLPLRW4824	\$135	\$135
TOTAL:				\$1,141

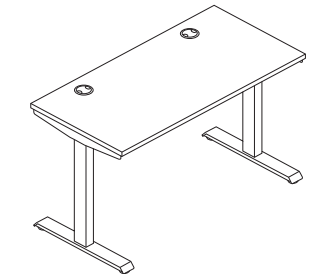

2-STAGE HEIGHT ADJUSTABLE TABLE

48" W x 24" D

MOD Bundles Typicals

Nickel/Traditional Mahogany
HLPLRW6024CONHATTM1

Nickel/Sepia Walnut
HLPLRW6024CONHATSE1

Nickel/Russet Cherry
HLPLRW6024CONHATRC1

Nickel/Slate Teak
HLPLRW6024CONHATSL1

Nickel/Java Oak
HLPLRW6024CONHATJA1

Nickel/Simply White
HLPLRW6024CONHATPW1

QTY	DESCRIPTION	MODEL	LIST PRICE	PRICE EXTENSION
1	Height Adjustable Base, 2-Stage	HHABETA2S2L	\$728	\$728
1	Rectangular Worksurface	HLPLRW6024	\$139	\$139
TOTAL:				\$867

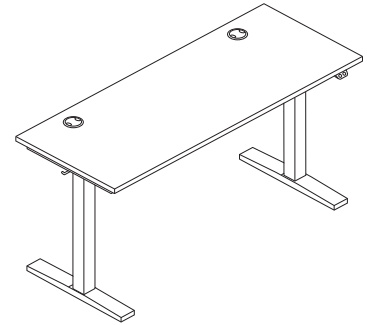

CONSUMER HEIGHT ADJUSTABLE TABLE
60"W x 24"D

Nickel/Traditional Mahogany
HLPLRW6030CONHATTM1

Nickel/Sepia Walnut
HLPLRW6030CONHATSE1

Nickel/Russet Cherry
HLPLRW6030CONHATRC1

Nickel/Slate Teak
HLPLRW6030CONHATSL1

Nickel/Java Oak
HLPLRW6030CONHATJA1

Nickel/Simply White
HLPLRW6030CONHATPW1

QTY	DESCRIPTION	MODEL	LIST PRICE	PRICE EXTENSION
1	Height Adjustable Base, 2-Stage	HHABETA2S2L	\$728	\$728
1	Rectangular Worksurface	HLPLRW6030	\$169	\$169
TOTAL:				\$897

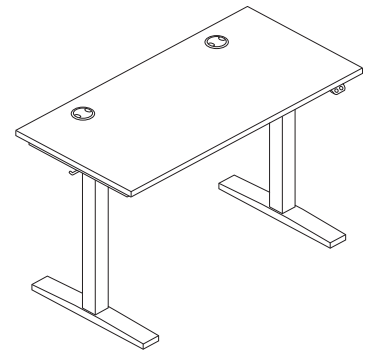

CONSUMER HEIGHT ADJUSTABLE TABLE
60"W x 30"D

Nickel/Traditional Mahogany
HLPLRW4824CONHATTM1

Nickel/Sepia Walnut
HLPLRW4824CONHATSE1

Nickel/Russet Cherry
HLPLRW4824CONHATRC1

Nickel/Slate Teak
HLPLRW4824CONHATSL1

Nickel/Java Oak
HLPLRW4824CONHATJA1

Nickel/Simply White
HLPLRW4824CONHATPW1

QTY	DESCRIPTION	MODEL	LIST PRICE	PRICE EXTENSION
1	Height Adjustable Base, 2-Stage	HHABETA2S2L	\$728	\$728
1	Rectangular Worksurface	HLPLRW4824	\$135	\$135
TOTAL:				\$863

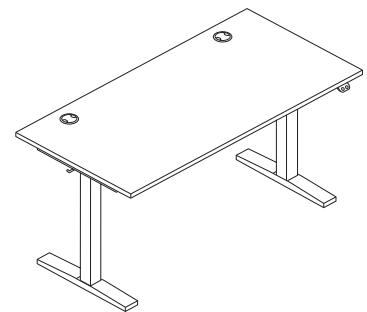

CONSUMER HEIGHT ADJUSTABLE TABLE
48"W x 24"D

MOD

Laminate Modular Components

OPEN MARKET



Icon Legend on page 19

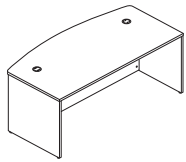

HLPLDS7236B shown

DESCRIPTION**Desk Shell**

72"W x 36"/30"D x 29"H, Bow Top
 72"W x 36"D x 29"H, Rectangle Top
 72"W x 30"D x 29"H, Rectangle Top
 66"W x 30"D x 29"H, Rectangle Top
 60"W x 30"D x 29"H, Rectangle Top
 48"W x 30"D x 29"H, Rectangle Top

MODEL**SHIP WEIGHT****CUBE****LIST PRICE**

HLPLDS7236B	149	6.6	\$353
HLPLDS7236	149	6.6	\$300
HLPLDS7230	149	5.6	\$295
HLPLDS6630	116	5.1	\$279
HLPLDS6030	111	4.7	\$255
HLPLDS4830	75	4.7	\$245

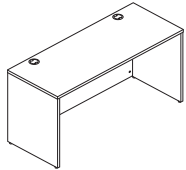
**Credenza Shell**

72"W x 24"D x 29"H
 66"W x 24"D x 29"H
 60"W x 24"D x 29"H
 48"W x 24"D x 29"H

HLPLCS7224	108	5.3	\$270
HLPLCS6624	96	4.8	\$260
HLPLCS6024	96	4.4	\$240
HLPLCS4824	75	3.7	\$235

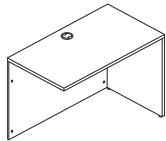
**Return Shell**

48"W x 24"D x 29"H
 42"W x 24"D x 29"H
 36"W x 24"D x 29"H

HLPLRS4824	66	4.2	\$198
HLPLRS4224	60	4.2	\$189
HLPLRS3624	54	2.8	\$157

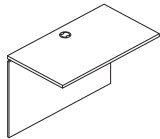
**Bridge**

48"W x 24"D x 29"H
 42"W x 24"D x 29"H
 36"W x 24"D x 29"H

HLPLB4824	53	4.2	\$161
HLPLB4224	46	4.2	\$159
HLPLB3624	40	3.7	\$133

NOTES:

- Scratch- and stain-resistant thermal-fused laminate surfaces.
- Durable 1" thick tops and end panels.
- Full height modesty panels.
- Desk, Credenza, Return Shells, and Bridge assemble quickly and easily.
- Desks, Credenzas, Return Shells, and Bridges come standard with 3" round Black grommets.
- Adjustable floor leveling glides provide 3/4" of adjustment.
- **HON 5-Year Limited Warranty.**

HOW TO SPECIFY

Select Model Number	Select Woodgrain Laminate
HLPLDS6030	See page 121
LSL1	

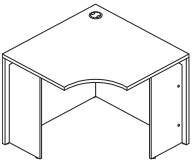

MOD Laminate Modular Components

	DESCRIPTION	MODEL	SHIP WEIGHT	CUBE	LIST PRICE
	Corner Shell 36"W x 36"D x 29"H 30"W x 24"D x 29"H	HLPLCS36 HLPLCS30	114 93	5.3 3.2	\$254 \$229
	Peninsula w/End Panel 72"W x 36"D x 29"H 66"W x 30"D x 29"H ⓘ Peninsula must be ganged to another unit, return, or bridge. ⓘ Support column available in Black only. Specify: Model.Woodgrain Laminate.Paint SPECIFYING EXAMPLE: HLPLPEN6630.LSL1.BLKP	HLPLPEN7236 HLPLPEN6630	116 91	14.6 11.4	\$325 \$288

NOTES:

- Scratch- and stain-resistant thermal-fused laminate surfaces.
- Durable 1" thick tops and end panels.
- Full height modesty panels.
- Corner Shells and Peninsula assemble quickly and easily.
- Corner Shells come standard with 3" round Black grommets.
- Adjustable floor leveling glides provide 3/4" of adjustment.
- **HON 5-Year Limited Warranty.**

HOW TO SPECIFY

<p>Select Model Number</p> <p>HLPLCS30.</p>	<p>Select Woodgrain Laminate</p> <p>See page 121</p> <p>LSL1</p>
---	--

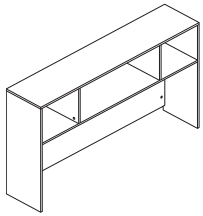
**DESCRIPTION****Hutch without Doors**

72"W x 14"D x 39³/₄"H
66"W x 14"D x 39³/₄"H
60"W x 14"D x 39³/₄"H

NOTES: Full back with gap at bottom for wire management.
Specify: Model.Woodgrain Laminate

! Hutch and Wall Mounted Storage units are sold without doors. 2 Doors or 4 Doors can be added to 72"W, 66"W, and 60"W units. 48"W Wall Mounted Storage Doors are sold in packages of 3 only.

SPECIFYING EXAMPLE: HLPLPEN6630.LSL1

MODEL**SHIP WEIGHT****CUBE****LIST PRICE**

HLPLDH72	106	7.1	\$316
HLPLDH66	99	7.2	\$301
HLPLDH60	92	5.3	\$293

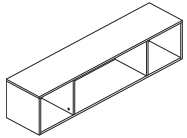
**Wall Mounted Storage without Doors**

72"W x 14"D x 13¹/₂"H
66"W x 14"D x 13¹/₂"H
60"W x 14"D x 13¹/₂"H
48"W x 14"D x 13¹/₂"H

! Hutch and Wall Mounted Storage units are sold without doors. 2 Doors or 4 Doors can be added to 72"W, 66"W, and 60"W units. 48"W Wall Mounted Storage Doors are sold in packages of 3 only.

HLPLWMH72	66	3.1	\$376
HLPLWMH66	62	3.6	\$361
HLPLWMH60	57	3.0	\$353
HLPLWMH48	48	2.5	\$338

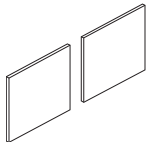
**Laminate Doors for Hutch and Wall Mounted Storage**

2 Pack, for HLPLDH72 and HLPLWMH72
2 Pack, for HLPLDH66 and HLPLWMH66
2 Pack, for HLPLDH60 and HLPLWMH60
3 Pack, for HLPLWMH48

HLPLDR72LM	12	0.8	\$36
HLPLDR66LM	12	0.8	\$36
HLPLDR60LM	12	0.8	\$36
HLPLDR48LM	17	0.8	\$54

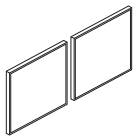
**Glass Doors for Hutch and Wall Mounted Storage**

2 Pack, for HLPLDH72 and HLPLWMH72
2 Pack, for HLPLDH66 and HLPLWMH66
2 Pack, for HLPLDH60 and HLPLWMH60
3 Pack, for HLPLWMH48

HLPLDR72GS	9	0.8	\$131
HLPLDR66GS	9	0.8	\$131
HLPLDR60GS	9	0.8	\$131
HLPLDR48GS	13	0.8	\$198

NOTES: No specification needed.

SPECIFYING EXAMPLE: HLPLDR66GS

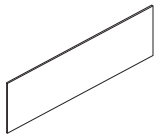
**Tackboards**

72"W x 18"H
66"W x 18"H
60"W x 18"H
48"W x 18"H

HLPLTACK72	12	2.4	\$115
HLPLTACK66	12	2.2	\$110
HLPLTACK60	10	2.1	\$105
HLPLTACK48	8	1.7	\$95

Specify: Model.Fabric

SPECIFYING EXAMPLE: HLPLTACK66.CN02

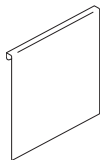
**Markerboard**

12"W x 12"H

HLPLDR12MB	3	0.6	\$65
-------------------	---	-----	-------------

NOTES: No specification needed. Markerboard is designed to fit over the top of the laminate doors for hutches to create a writable/movable surface.

SPECIFYING EXAMPLE: HLPLDR12MB

NOTES:

- Scratch- and stain-resistant thermal-fused laminate surfaces.
- Durable ⁵/₈" thick tops and end panels.
- 72"W, 66"W, and 60"W hutches include fully enclosed back.
- Hutches and Wall Mounted Storage assemble quickly and easily.
- **HON 5-Year Limited Warranty.**

HOW TO SPECIFY

Select
Model Number

HLPLWMH66

Select
Laminate

See page 121

LSL1

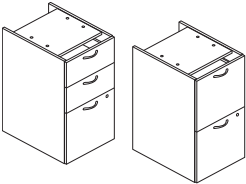
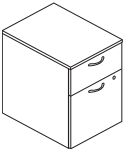

Laminate Modular Storage Components

	DESCRIPTION	MODEL	SHIP WEIGHT	CUBE	LIST PRICE
	Support Pedestal 15"W x 20"D x 28"H, Box/Box/File 15"W x 20"D x 28"H, File/File NOTES: Optional Pulls available, see below. ⓘ Top is unfinished. Not to be used freestanding.	HLPLPSBBF HLPLPSFF	81.0 79.0	7.4 7.4	\$311 \$311
	Hanging Pedestal 15"W x 20"D x 20"H, Box/File NOTES: Optional Pulls available, see below. ⓘ Top is unfinished. Not to be used freestanding. ⓘ Hanging Pedestal is designed to attach to the underside of the worksurface and is non-handed (can be assembled on left or right side).	HLPLPHBF	63.0	5.8	\$228
 HLPLPMBF shown	Mobile Pedestal 15"W x 20"D x 28"H, Box/Box/File 15"W x 20"D x 28"H, File/File 15"W x 20"D x 20"H, Box/File NOTES: Optional Pulls available, see below.	HLPLPMBBF HLPLPMFF HLPLPMBF	81.0 79.0 63.0	7.4 7.4 5.8	\$383 \$383 \$272
	Pedestal Cushion 15"W x 20"D Specify: Model.Fabric SPECIFYING EXAMPLE: HLPLPSEAT1520.CN02	HLPLPSEAT1520	6.0	1.1	\$86
	Field Installed Contemporary Pull — 2-pack Silver NOTES: For use on Lateral Files, Pedestals, Wardrobe, and 2-Drawer Low Credenza. ⓘ Silver finish only, no specification needed.	HBLPCONTEMP	0.4 ⓘ	0.1	\$12
Field Installed Bridge Pull — 2-pack Silver NOTES: For use on Lateral Files, Pedestals, Wardrobe, and 2-Drawer Low Credenza. ⓘ Polished finish only, no specification needed.	HBLPBRIDGE	0.4 ⓘ	0.1	\$12	
Field Installed Classic Pull — 2-pack Black NOTES: For use on Lateral Files, Pedestals, Wardrobe, and 2-Drawer Low Credenza. ⓘ Black finish only, no specification needed.	HBLPCLASSIC	0.4 ⓘ	0.1	\$12	

NOTES:

- Pedestals ship assembled.
- Support Pedestals are designed to be used under a desk, credenza, or return shell.
- Drawers operate on full extension, ball-bearing suspensions to ensure smooth, quiet, and long-lasting operation.
- Pedestals come standard with Arch pull in Silver finish.
- **HON 5-Year Limited Warranty.**

HOW TO SPECIFY

Select Model Number HLPLPSBBF	Select Laminate See page 121 LSL1
---	--

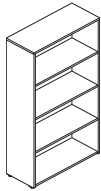

HLPLBC3013B5 shown

DESCRIPTION**Bookcase**

30"W x 13"D x 65"H, 5-Shelf, 3 Adjustable Shelves, 1 Fixed Shelf
 30"W x 13"D x 53"H, 4-Shelf, 2 Adjustable Shelves, 1 Fixed Shelf
 30"W x 13"D x 29"H, 2-Shelf, 1 Fixed Shelf

MODEL

HLPLBC3013B5
HLPLBC3013B4
HLPLBC3013B2

SHIP WEIGHT

137
 112
 63

CUBE

6.1
 5.2
 3.2

LIST PRICE

\$306
\$219
\$150

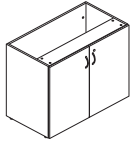
**Storage Cabinet**

36"W x 20"D x 29"H

HLPLSC3620

76

15.7

\$356

NOTES: Optional Pulls available, see page 133.

! Top is unfinished, not to be used freestanding. To convert to a freestanding cabinet, order model HLPLCL3620TOP, see page 136.

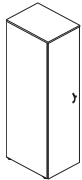
**Wardrobe**

24"W x 24"D x 65"H
 18"W x 24"D x 65"H

HLPLW2424
HLPLW1824

99
 84

4.2
 4.2

\$796
\$521

NOTES: Optional Pulls available, see page 133. Non-handed door which can be installed in left- or right-hand configuration. Coat rod, fixed shelf, and lock included.

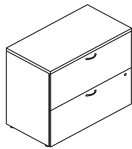

HLPLLF3620L2 shown

Lateral

36"W x 20"D x 53"H, 4-Drawer
 36"W x 20"D x 40"H, 3-Drawer
 36"W x 20"D x 29"H, 2-Drawer w/Removable Top

HLPLLF3620L4
HLPLLF3620L3
HLPLLF3620L2

193
 166
 145

27.4
 21.1
 15.7

\$887
\$784
\$504

NOTES: Optional Pulls available, see page 133.

! 2-Drawer Lateral, HLPLLF3620L2, available in all Laminate finishes including Simply White.

! Simply White is not an available option on either the 3-Drawer or 4-Drawer Laterals.

! To change the top of model HLPLLF3620L2 in order to make a two-tone unit, use model HLPLCL3620TOP, see page 136.

NOTES:

- Lateral files ship assembled.
- Drawers operate on full extension, ball-bearing suspensions to ensure smooth, quiet, and long-lasting operation.
- Hangrails are included in each file drawer for side-to-side legal filing, and for front-to-back letter and legal filing.
- Storage Cabinet, Wardrobe, and Lateral Files come standard with Arch pull in Silver finish.
- **HON 5-Year Limited Warranty.**

HOW TO SPECIFY

Select
Model Number

H L P L B C 3 0 1 3 B 5 .

Select
Woodgrain Laminate

See page 121

L S L 1

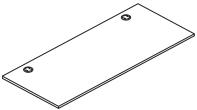
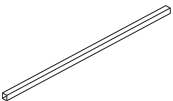
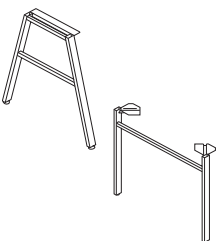
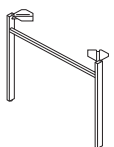
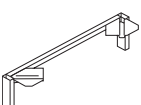
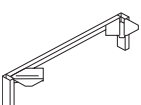
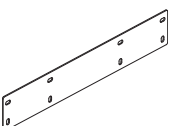

	DESCRIPTION	MODEL	SHIP WEIGHT	CUBE	LIST PRICE		
	Rectangular Worksurface 72"W x 30"D 72"W x 24"D	HLPLRW7230 HLPLRW7224	110 89	6.0 4.9	\$191 \$157		
	66"W x 30"D 66"W x 24"D	HLPLRW6630 HLPLRW6624	101 82	5.5 4.5	\$179 \$147		
	60"W x 30"D 60"W x 24"D	HLPLRW6030 HLPLRW6024	92 75	5.0 4.1	\$169 \$139		
	48"W x 30"D 48"W x 24"D	HLPLRW4830 HLPLRW4824	75 61	4.1 3.4	\$161 \$135		
	Specify: Model.Laminate SPECIFYING EXAMPLE: HLPLRW6630.LSL1						
		External Stiffener For 72"W Worksurfaces For 66"W Worksurfaces For 60"W Worksurfaces	HLPLXS72 HLPLXS66 HLPLXS60	7 7 6	0.7 0.6 0.6	\$75 \$70 \$65	
		ⓘ Available in Graphite paint only. SPECIFYING EXAMPLE: HLPLXS66.BLKP					
			A-Leg Support 30"W Angled Leg 24"W Angled Leg	HLPLLEG30A HLPLLEG24A	16 14	5.1 3.7	\$144 \$135
			NOTES: A-Leg will have adjustable floor leveling glides which provide 2" of adjustment.				
		U-Leg Support 30"W U-Leg 24"W U-Leg	HLPLLEG30U HLPLLEG24U	17 15	5.1 3.7	\$144 \$135	
NOTES: U-Leg will have adjustable floor leveling glides which provide 3" of adjustment.							
	Credenza Leg Support 7"H x 30"D Support Leg 7"H x 24"D Support Leg	HLPLSL30 HLPLSL24	6 5	1.0 1.0	\$94 \$86		
		Overhead Support Leg 23"H, Pack of 2 10½"H, Pack of 2	HLPLOS23 HLPLOS10	13 9	1.1 0.8	\$135 \$105	
		Flat Bracket 24"D Bracket	HLPLFB24	3	0.6	\$45	
	ⓘ Available in Graphite paint only, no paint selection. SPECIFYING EXAMPLE: HLPLFB24						

NOTES:

- Scratch- and stain-resistant thermal-fused laminate surfaces.
- Durable 1" thick tops.
- Worksurfaces come standard with 3" round Black grommets.
- **HON 5-Year Limited Warranty.**

HOW TO SPECIFY

<p>Select Model Number</p>	<p>Select Paint Color</p> <p>See page 121</p>
<p>HLPLLEG30A.</p>	<p>BLKP</p>

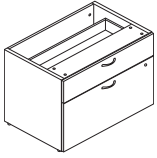
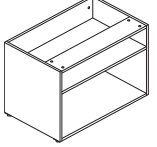
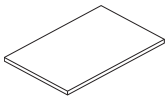
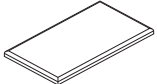

	DESCRIPTION	MODEL	SHIP WEIGHT	CUBE	LIST PRICE
	Low Credenza, 2 Drawers, Personal Cabinet, No Top 36"W x 20"D x 21"H 30"W x 20"D x 21"H NOTES: Optional Pulls available, see page 133. Unit ships fully assembled. Two low credenza units (2 drawer or Open Storage) can be combined using 1 top to create 60", 66", or 72" low credenzas. ! Top is unfinished, not to be used freestanding. Use with low credenza tops below to create a finished credenza.	HLPLCL3620BF	113	11.8	\$516
		HLPLCL3020BF	80	10.1	\$505
	Low Credenza, 2 Open Shelves, Open Storage Cabinet, No Top 36"W x 20"D x 21"H 30"W x 20"D x 21"H NOTES: Unit ships flat packed; assembly required. Two low credenza units (2 drawer or Open Storage) can be combined using 1 top to create 60", 66", or 72" low credenzas. ! Top is unfinished, cannot be used without a top. Use with low credenza tops below to create a finished credenza.	HLPLCL3620S	63	3.0	\$243
		HLPLCL3020S	48	2.5	\$232
	Low Credenza Cabinet Top 72"W x 20"D 66"W x 20"D 60"W x 20"D 36"W x 20"D 30"W x 20"D	HLPLCL7220TOP	74	4.2	\$127
		HLPLCL6620TOP	68	3.9	\$125
		HLPLCL6020TOP	63	3.5	\$116
		HLPLCL3620TOP	37	2.2	\$82
		HLPLCL3020TOP	30	1.9	\$75
	Low Credenza Cushion 36"W x 20"D 30"W x 20"D Specify: Model.Fabric SPECIFYING EXAMPLE: HLPLCSEAT3620.CN02	HLPLCSEAT3620	11	2.2	\$175
		HLPLCSEAT3020	9	1.9	\$180

NOTES:

- Scratch- and stain-resistant thermal-fused laminate surfaces.
- Durable 1" thick tops.
- Low credenzas ship assembled.
- Drawers operate on full extension, ball-bearing suspensions to ensure smooth, quiet, and long-lasting operation.
- Hangrails are included in each file drawer for side-to-side legal filing, and for front-to-back letter and legal filing.
- Low Credenza, 2 Drawer comes standard with Arch pull in Silver finish.
- **HON 5-Year Limited Warranty.**

HOW TO SPECIFY

Select Model Number HLPLCL3620BF	Select Laminate See page 121 LSL1
--	--

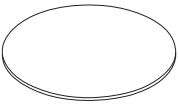
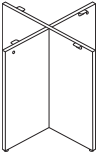
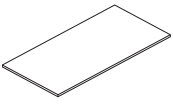
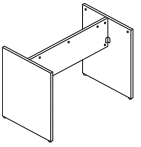

Conference Table Modular Components

	DESCRIPTION	MODEL	SHIP WEIGHT	CUBE	LIST PRICE
	Round Conference Table Tops				
	48" Round Top	HLPLTBL48RND	63	6.5	\$201
	42" Round Top	HLPLTBL42RND	50	5.1	\$196
	36" Round Top	HLPLTBL36RND	39	3.8	\$161
	Round Conference Table Bases				
	X-Base for 48" Table Tops	HLPLTBL48BASE	45	3.2	\$84
	X-Base for 42" Table Tops	HLPLTBL42BASE	42	3.2	\$81
	X-Base for 36" Table Tops	HLPLTBL36BASE	36	2.5	\$78
	Rectangle Conference Table Tops				
	48"W x 120"L Rectangular Top, 2-Piece	HLPLTBL48120RCT	293	7.8	\$658
	42"W x 96"L Rectangular Top	HLPLTBL4296RCT	205	10.7	\$453
	36"W x 72"L Rectangular Top	HLPLTBL3672RCT	132	7.1	\$267
	Rectangle Conference Table Bases				
	Slab Base for 120" Table Tops	HLPLTBL120BASE	86	4.2	\$105
	Slab Base for 96" Table Tops	HLPLTBL96BASE	64	5.1	\$100
	Slab Base for 72" Table Tops	HLPLTBL72BASE	48	3.0	\$95

NOTES:

- Scratch- and stain-resistant thermal-fused laminate surfaces.
- Durable 1" thick tops and support legs.
- **HON 5-Year Limited Warranty.**

HOW TO SPECIFY

<p>Select Model Number</p> <p>HLPLTBL42RND</p>	<p>Select Laminate</p> <p>See page 121</p> <p>LSL1</p>
--	--

MOD

Reception Modular Components

OPEN MARKET

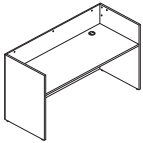
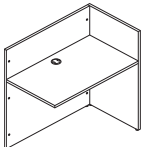
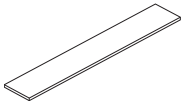

Icon Legend on page 19

	DESCRIPTION	MODEL	SHIP WEIGHT	CUBE	LIST PRICE
	Reception Desk Shell 72"W x 30"D x 41"H	HLPLRCPNDS7230	182	8.3	\$406
	Reception Return Shell 42"W x 25"D x 41"H	HLPLRCPNRS4225	110	5.1	\$245
	Transaction Tops 72"W x 12"D Laminate	HLPLRCPNTPLM	45	3.5	\$86
	72"W x 12"D Frosted Glass	HLPLRCPNTPGS	35	3.2	\$304
	<p>ⓘ Laminate Transaction Top, HLPLRCPNTPLM, available in all Laminate finishes including Simply White.</p> <p>ⓘ No selection for Glass Transaction Top, only one finish option.</p>				

NOTES:

- Scratch- and stain-resistant thermal-fused laminate surfaces.
- Durable 1" thick tops and end panels.
- Adjustable floor leveling glides provide 3/4" of adjustment.
- Reception stations assemble quickly and easily.
- 3" round Black grommet(s) in tops of desks to route cords.
- **HON 5-Year Limited Warranty.**

HOW TO SPECIFY

Select Model Number	Select Woodgrain Laminate
HLPLRCPNDS7230	See page 121
LSL1	



Valido® shown with Preside® Conference Table, HON® Occasional Tables, Flock® and Ignition® seating.

VALIDO®

Valido knows how to make them. Impeccable design. Quality craftsmanship. A tailored, signature style that lasts. With precision-machined edges and more than 100 different surface combinations, Valido lets you create a custom-built look with an executive edge. And thanks to a variety of flexible component options — plus high-quality laminate that resists scratches, stains, spills and wear — Valido is the very definition of form meeting function.



FEATURES

- Formal 1½-thick worksurfaces are finished with an elegant, ribbon-edge detail.
- Multiple storage options let you create spaces that work the way you do.
- Valido components are designed to fit, form and grow into every area and any space.
- Metal-to-metal fastening system for precise fit and unsurpassed durability.
- Available in durable mix-and-match laminates, including woodgrain, solid, and pattern colors.
- Four decorative handle options to choose from.

VALIDO® ORDERING INFORMATION

LAMINATE FINISHES AVAILABILITY

L1 LAMINATES CODES

Woodgrain

- ◆ Bourbon Cherry **HH**
- ◆ Cognac **COGNCOGN**
- ◆ Florence Walnut **LFWILFW1**
- ◆ Harvest **CC**
- ◆ Kingswood Walnut **LK1LKI1**
- ◆ Mahogany **NN**
- ◆ Mocha **MOCHMOCH**
- ◆ Natural Maple **DD**
- ◆ Pinnacle **PINCPINC**
- ◆ Shaker Cherry **FF**
- ◆ Sterling Ash **LSA1LSA1**

Solid

- ◆ Black **PP**
- ◆ Charcoal **SS**
- ◆ Designer White **LDWILDW1**

Patterned Top

- ◆ Grey Tigris **L6(*)**
- ◆ Sheer Mesh **A5(*)**
- ◆ Silver Mesh **B9(*)**
- ◆ Canyon Zephyr **K9(*)**
- ◆ Desert Zephyr **K8(*)**

(*) Patterned top laminates are available with the following base/edgebanding laminate selection: C, COGN, D, F, H, MOCH, N, P, PINC, S, or WHIT. Edgebanding will match base laminate selected.

SPECIFYING EXAMPLE: H11592.L6N

The following Valido products are not available as two-tone and require only one color code:

- Modular pedestals — box/file, box/box/file, file/file, lateral file, multi file, and cabinet.

◆◆◆ For lead time information see page 19.

Patterned Top

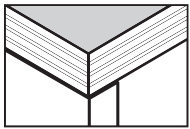

Edgeband Around Top / Laminate Base

- Edgebanding on patterned laminates matches the laminate base selected.

• LAMINATE DESKS
SPECIFY: Model Number.
Laminate

EXAMPLE: H11596.NN

• WORKSURFACES
SPECIFY: Model Number.
Top Laminate
Edgeband

- All specifications in this publication are based on the latest product information available at the time of print.

! Tops with a patterned color are not available with a matching edgeband.

Edge Option:



Ribbon Edge "A"

Handle Options:



Sweep Designator
Black A
Satin Nickel C

4 5/8"W



Crescent Designator
Black D
Satin Nickel F

5"W

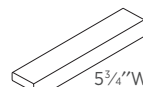

Linear
Black G
Matte Chrome J

5 3/4"W

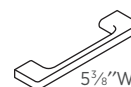

Arch
Black K
Matte Chrome M

5 3/8"W

TWO-TONE LAMINATE TOP / BASE

L1 LAMINATES CODES

Two-Tone Top/Base

- ◆ Black/Charcoal **PS**
- ◆ Black/Designer White ... **PLDW1**
- ◆ Bourbon Cherry/Black **HP**
- ◆ Bourbon Cherry/Charcoal ... **HS**
- ◆ Bourbon Cherry/Designer
White **HLDW1**
- ◆ Charcoal/Black **SP**
- ◆ Charcoal/Designer
White **SLDW1**
- ◆ Cognac/Black **COGNP**
- ◆ Cognac/Charcoal **COGNS**
- ◆ Cognac/Designer
White **COGNLDW1**
- ◆ Designer White/Black ... **LDW1P**
- ◆ Designer White/Bourbon
Cherry **LDW1H**
- ◆ Designer
White/Charcoal **LDW1S**
- ◆ Designer
White/Cognac **LDW1COGN**
- ◆ Designer
White/Harvest **LDW1C**
- ◆ Designer
White/Mahogany **LDW1N**
- ◆ Designer
White/Mocha **LDW1MOCH**
- ◆ Designer White/Natural
Maple **LDW1D**
- ◆ Designer
White/Pinnacle **LDW1PINC**
- ◆ Designer White/Shaker
Cherry **LDW1F**
- ◆ Florence Walnut/Black . **LFW1P**
- ◆ Florence
Walnut/Charcoal **LFW1S**

◆◆◆ For lead time information see page 19.

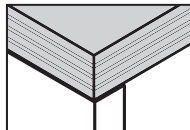

Laminate Base

Two-tone laminates: Top and edgebanding are the same, base is different laminate color.

- Edgebanding on two-tone laminates matches top, base is a different laminate color.
- A complete selection of Conference Room and Occasional Tables is shown in the Tables section in the 2021 Shared Spaces Pricer.

• LAMINATE DESKS
SPECIFY: Model Number.
Laminate

EXAMPLE: H11596.HP

- All specifications in this publication are based on the latest product information available at the time of print.

TWO-TONE LAMINATE TOP / BASE

continued

L1 LAMINATES CODES

Two-Tone Top/Base

- ◆ Florence Walnut/Designer
White **LFWILDW1**
- ◆ Harvest/Black **CP**
- ◆ Harvest/Charcoal **CS**
- ◆ Harvest/Designer
White **CLDW1**
- ◆ Kingswood
Walnut/Black **LK11P**
- ◆ Kingswood
Walnut/Charcoal **LK11S**
- ◆ Kingswood Walnut/Designer
White **LK11LDW1**
- ◆ Mahogany/Black **NP**
- ◆ Mahogany/Charcoal **NS**
- ◆ Mahogany/Designer
White **NLDW1**
- ◆ Mocha/Black **MOCHP**
- ◆ Mocha/Charcoal **MOCHS**
- ◆ Mocha/Designer
White **MOCHLDW1**
- ◆ Natural Maple/Black **DP**
- ◆ Natural Maple/Charcoal **DS**
- ◆ Natural Maple/Designer
White **DLDW1**
- ◆ Pinnacle/Black **PINCP**
- ◆ Pinnacle/Charcoal **PINCS**
- ◆ Pinnacle/Designer
White **PINCLDW1**
- ◆ Shaker Cherry/Black **FP**
- ◆ Shaker Cherry/Charcoal **FS**
- ◆ Shaker Cherry/Designer
White **FLDW1**
- ◆ Sterling Ash/Black **LSA1P**
- ◆ Sterling Ash/Charcoal **LSA1S**
- ◆ Sterling Ash/Designer
White **LSA1LDW1**



Icon Legend on page 19

Components used are listed on pages 144-166. Order components individually. Other configurations are possible, including various sizes of some components.

QTY	DESCRIPTION	MODEL	LIST PRICE	PRICE EXTENSION
1	Double Pedestal Desk - 2/2 72"W x 36"D x 29½"H	H11593	\$1,795	\$1,795
1	Credenza with Kneespace - 2/2 72"W x 24"D x 29½"H	H11543	\$1,663	\$1,663
1	Stack-on Storage 72"W x 14⅝"D x 37½"H	H11534	\$1,291	\$1,291
2	Vertical Paper Manager	HLVPM1	\$327	\$654
TOTAL:			\$5,403	

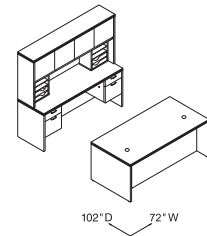

DESK/CREDENZA
72"W x 102"D

QTY	DESCRIPTION	MODEL	LIST PRICE	PRICE EXTENSION
1	Double Pedestal Bow Top Desk - 2/2 72"W x 36"D x 29½"H	H11595	\$1,959	\$1,959
1	Credenza with Kneespace - 2/2 72"W x 24"D x 29½"H	H115900	\$2,067	\$2,067
1	Stack-on Storage 72"W x 14⅝"D x 37½"H	H11534	\$1,291	\$1,291
1	Personal Wardrobe/Storage Cabinet, Left 18"W x 24"D x 67"H	H115296L	\$1,777	\$1,777
1	Storage/File Cabinet, Right 18"W x 24"D x 67"H	H115297R	\$2,055	\$2,055
TOTAL:			\$9,149	

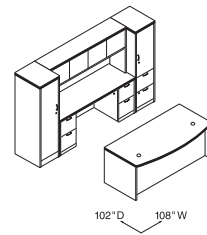

DESK/CREDENZA
108"W x 102"D

QTY	DESCRIPTION	MODEL	LIST PRICE	PRICE EXTENSION
1	Single Pedestal Desk, Left - B/F 72"W x 36"D x 29½"H	H11586L	\$1,525	\$1,525
1	Return, Right - B/F 48"W x 24"D x 29½"H	H11515R	\$1,110	\$1,110
1	Stack-on Storage 48"W x 14⅝"D x 37½"H	H115323	\$1,049	\$1,049
1	Square End Cap Bookshelf 24"W x 24"D x 29½"H	H115525R	\$752	\$752
TOTAL:			\$4,436	

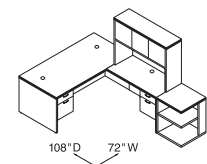

"L" WORKSTATION
72"W x 108"D

QTY	DESCRIPTION	MODEL	LIST PRICE	PRICE EXTENSION
1	Single Pedestal Desk, Left - B/F 66"W x 30"D x 29½"H	H11584L	\$1,426	\$1,426
1	Return, Right - B/F 48"W x 24"D x 29½"H	H11515R	\$1,110	\$1,110
1	Stack-on Storage 78"W x 14⅝"D x 37½"H	H115327	\$1,437	\$1,437
1	Vertical Paper Manager	HLVPM1	\$327	\$327
1	End Cap Bookshelf 24"W x 24"D x 29½"H	H115520	\$763	\$763
1	End Cap Bookshelf 15"W x 15"D x 37½"H	H115523	\$675	\$675
TOTAL:			\$5,738	

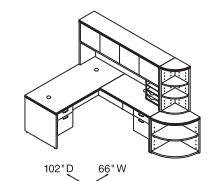

"L" WORKSTATION
66"W x 102"D



Components used are listed on pages 144-166. Order components individually. Other configurations are possible, including various sizes of some components.

QTY	DESCRIPTION	MODEL	LIST PRICE	PRICE EXTENSION
1	Single Pedestal Desk, Right - B/F 72"W x 36"D x 29½"H	H11585R	\$1,525	\$1,525
1	Bridge 47"W x 24"D x 29½"H	H11570	\$505	\$505
1	Credenza with 36" Lateral, Left 72"W x 24"D x 29½"H	H11548L	\$1,784	\$1,784
1	Stack-on Storage 72"W x 14⅝"D x 37½"H	H11534	\$1,291	\$1,291
1	Storage Cabinet/Lateral File 36"W x 24"D x 67"H	H115293	\$2,665	\$2,665
TOTAL:			\$7,770	

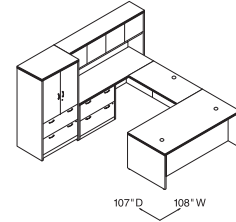

"U" WORKSTATION
108"W x 107"D

QTY	DESCRIPTION	MODEL	LIST PRICE	PRICE EXTENSION
1	Single Full Pedestal Bow Front Desk 72"W x 36"D x 29½"H	H115893R	\$2,139	\$2,139
1	Bridge 42"W x 24"D x 29½"H	H11560	\$483	\$483
1	Left Single Full Pedestal Credenza 72"W x 24"D x 29½"H	H115904L	\$1,701	\$1,701
1	Stack-on Storage 72"W x 14⅝"D x 37½"H	H11534	\$1,291	\$1,291
1	Vertical Paper Manager	HLVPM1	\$327	\$327
1	Personal Wardrobe/Storage Cabinet 36"W x 24"D x 67"H	H11530	\$2,603	\$2,603
TOTAL:			\$8,544	

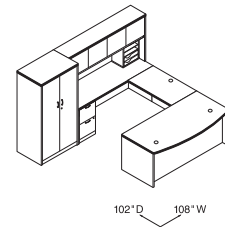

"U" WORKSTATION
108"W x 102"D

QTY	DESCRIPTION	MODEL	LIST PRICE	PRICE EXTENSION
1	Single Pedestal Bow Front Desk, Right - B/F 72"W x 36"D x 29½"H	H11587R	\$1,727	\$1,727
1	Bridge 36"W x 24"D x 29½"H	H115599	\$483	\$483
1	36" Corner Unit	H115811	\$902	\$902
1	Return, Left 42"W x 24"D x 29½"H	H11512L	\$1,097	\$1,097
1	Stack-on Storage 78"W x 14⅝"D x 37½"H	H115327	\$1,437	\$1,437
1	Vertical Paper Manager	HLVPM1	\$327	\$327
1	Personal Storage Tower 24"W x 24"D x 67"H	H115301R	\$2,603	\$2,603
TOTAL:			\$8,576	

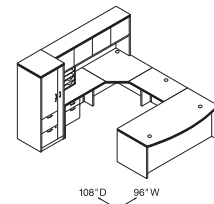

"U" WORKSTATION
102"W x 108"D

QTY	DESCRIPTION	MODEL	LIST PRICE	PRICE EXTENSION
1	Extended Corner Unit, Left 24"D x 72"W x 36"D x 24"W x 29½"H	H115816L	\$1,308	\$1,308
1	Box/Box/File Mobile Pedestal 15⅝"W x 22¾"D x 28"H	H115102	\$939	\$939
1	Stack-on Storage 72"W x 14⅝"D x 37½"H	H11534	\$1,291	\$1,291
1	Vertical Paper Manager	HLVPM1	\$327	\$327
1	Return Shell (with Full Modesty Panel) 48"W x 24"D x 29½"H	H11561	\$689	\$689
1	File/File Mobile Pedestal 15⅝"W x 22¾"D x 28"H	H115104	\$939	\$939
TOTAL:			\$5,493	

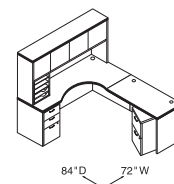

MODULAR "L" WORKSTATION
72"W x 84"D



Icon Legend on page 19

Components used are listed on pages 144-166. Order components individually. Other configurations are possible, including various sizes of some components.

QTY	DESCRIPTION	MODEL	LIST PRICE	PRICE EXTENSION
1	Jetty Peninsula, Left 72"W x 42"/30"D x 29½"H	H115202L	\$1,394	\$1,394
1	File/File Mobile Pedestal 15⅝"W x 22¾"D x 28"H	H115104	\$939	\$939
1	Return Shell 72"W x 24"D x 29½"H	H115686	\$900	\$900
1	Multi File Pedestal 36"W x 20"D x 28"H	H11505	\$1,406	\$1,406
2	Wall Mounted Storage Cabinet 42"W x 14⅝"D x 18⅞"H	H115382	\$988	\$1,976
1	Wall Mounted Storage Cabinet 30"W x 14⅝"D x 18⅞"H	H115380	\$872	\$872
1	End Cap Bookshelf 24"W x 24"D x 29½"H	H115520	\$763	\$763
TOTAL:			\$8,250	

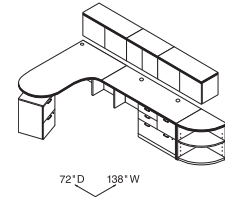

MODULAR "L" WORKSTATION
138"W x 72"D

QTY	DESCRIPTION	MODEL	LIST PRICE	PRICE EXTENSION
1	Storage/File Cabinet, Left 18"W x 24"D x 67"H	H115298L	\$2,055	\$2,055
1	Return Shell 72"W x 24"D x 29½"H	H115686	\$900	\$900
1	File/File Modular Pedestal 15⅝"W x 22¾"D x 28"H	H11504	\$767	\$767
1	Mobile Printer/Fax Cart 20"W x 19⅞"D x 14⅞"H	H105679	\$420	\$420
1	Stack-on Storage 72"W x 14⅝"D x 37½"H	H11534	\$1,291	\$1,291
1	Vertical Paper Manager	HLVPM1	\$327	\$327
1	36" Corner Unit	H115811	\$902	\$902
1	Stack-on Storage 36"W x 14⅝"D x 37½"H	H115321	\$865	\$865
1	Return Shell 60"W x 24"D x 29½"H	H115684	\$841	\$841
1	Multi File Pedestal 36"W x 20"D x 28"H	H11505	\$1,406	\$1,406
TOTAL:			\$9,774	

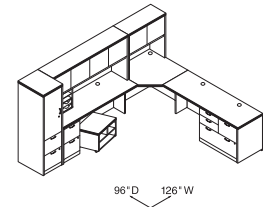

MODULAR "L" CORNER WORKSTATION
126"W x 96"D

QTY	DESCRIPTION	MODEL	LIST PRICE	PRICE EXTENSION
1	Boomerang Peninsula, Left 72"W x 42"/30"D x 29½"H	H115204L	\$1,394	\$1,394
1	Box/Box/File Mobile Pedestal 15⅝"W x 22¾"D x 28"H	H115102	\$939	\$939
1	Bridge 30"W x 24"D x 29½"H	H115598	\$483	\$483
1	Extended Corner Unit, Right 24"W x 36"D x 72"W x 24"D x 29½"H	H115815R	\$1,308	\$1,308
1	File/File Modular Pedestal 15⅝"W x 22¾"D x 28"H	H11504	\$767	\$767
1	Stack-on Storage 72"W x 14⅝"D x 37½"H	H11534	\$1,291	\$1,291
1	Storage/File Cabinet, Right 18"W x 24"D x 67"H	H115297R	\$2,055	\$2,055
1	End Cap Bookshelf 24"W x 24"D x 67"H	H115524	\$1,213	\$1,213
TOTAL:			\$9,450	

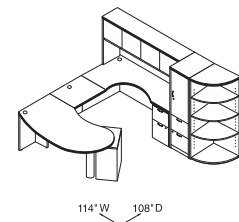

MODULAR "U" WORKSTATION
114"W x 108"D

VALIDO® Laminate Modular Desks

GSA SIN 33721



Icon Legend on page 19

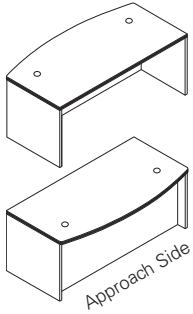

Model H11596 shown

DESCRIPTION

Desk Shell (with Full Modesty Panel)

- 72"W x 36"D x 29½"H, Bow Top (end panels 30"D)
- 72"W x 36"D x 29½"H, Rectangle Top
- 72"W x 30"D x 29½"H, Rectangle Top
- 66"W x 30"D x 29½"H, Rectangle Top
- 60"W x 30"D x 29½"H, Rectangle Top
- 48"W x 30"D x 29½"H, Rectangle Top (1 grommet)

NOTES: See page 164 for optional center drawers.

INSIDE DIMENSIONS

FULL WIDTH OVERHANG

MODEL

SHIP WEIGHT

CUBE

LIST PRICE

69½"W x 24⅝"D	10½"	H11596	218	5.8	\$1068
69½"W x 24⅝"D	10½"	H11594	239	5.8	\$1023
69½"W x 24⅝"D	4½"	H11592	206	6.6	\$954
63½"W x 24⅝"D	4½"	H11579	194	4.5	\$900
57½"W x 24⅝"D	4½"	H11578	182	4.1	\$862
45½"W x 24⅝"D	4½"	H11598	154	4.0	\$814

NOTES:

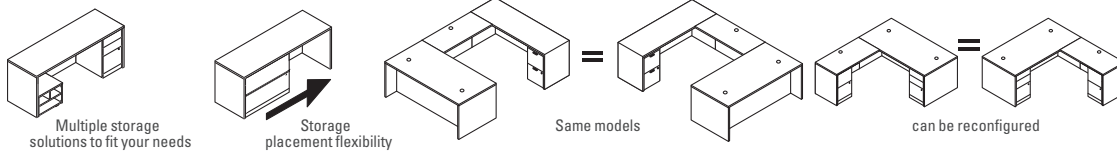

- Non-handed desk, credenza, and return shells, combined with a variety of under-the-worksurface storage solutions, maximize office layout flexibility. Shells and pedestals can be reconfigured quickly and easily when user preferences or space needs change.
- Tops are abrasion- and stain-resistant laminate over extra-thick 1½" solid core high-performance particleboard; resists warping.
- "Ribbon" edge profile; shape is on all four sides.
- Full height modesty panels.
- Cord management grommets, for routing and hiding wires and cables, are located in the tops of desk and return shells.
- 3" round worksurface grommet can be replaced with optional Power Hub (model HGRMTAC) or Power/USB Hub (model HGRMTUSB2) to bring the ease of plug-and-play to the desktop. See page 168.
- Credenza shells have a cord pass-through grommet in the top center of the modesty panel.
- The narrow design of the kneespace clearance end panel kits replace full end panels to provide added kneespace.
- Adjustable hex leveling glides allow floor-standing furniture to be easily leveled; glides have ¾" adjustable range.
- For conference table options, see the Preside® table tops and bases in the Tables section in the 2021 Shared Spaces Pricer. Order edge option "K".
- See pages 147-148 for modular storage components.



HOW TO SPECIFY

<p>Select Model Number</p> <p>H 1 1 5 9 6</p>	<p>Select Edge Profile</p> <p>See page 140</p> <p>A</p>	<p>Select Laminate</p> <p>See page 140</p> <p>N N</p>
--	--	--

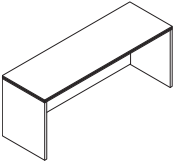
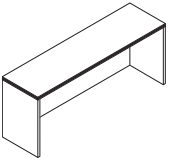
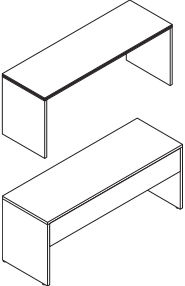

	DESCRIPTION	INSIDE DIMENSIONS	MODEL	SHIP WEIGHT	CUBE	LIST PRICE
 <p>Model H11541 shown</p>	24"D Credenza Shell (with Full Modesty Panel)					
	72"W x 24"D x 29½"H	69½"W x 22¾"D	H11541	169	4.5	\$900
	66"W x 24"D x 29½"H	63½"W x 22¾"D	H11542	159	4.2	\$875
	60"W x 24"D x 29½"H	57½"W x 22¾"D	H11564	148	3.8	\$841
	48"W x 24"D x 29½"H	45½"W x 22¾"D	H115692	135	2.8	\$791
	42¼"W x 24"D x 29½"H	39¾"W x 22¾"D	H115691	118	3.4	\$752
	NOTES: Cord pass-through grommet in top center of modesty panel. See pages 156-157 for optional stack-on storage.					
	20"D Credenza Shell (with Full Modesty Panel)					
	72"W x 20"D x 29½"H	69½"W x 18¾"D	H115581	154	5.3	\$852
	66"W x 20"D x 29½"H	63½"W x 18¾"D	H115582	145	4.8	\$826
	60"W x 20"D x 29½"H	57½"W x 18¾"D	H115583	135	4.4	\$796
	NOTES: Cord pass-through grommet in top center of modesty panel. See pages 156-157 for optional stack-on storage.					
	24"D Credenza Shell (with 10" Modesty Panel)					
	72"W x 24"D x 29½"H	69½"W x 22¾"D	H11541X	162	5.0	\$900
	66"W x 24"D x 29½"H	63½"W x 22¾"D	H11542X	124	4.0	\$875
	60"W x 24"D x 29½"H	57½"W x 22¾"D	H11564X	120	4.0	\$841
	48"W x 24"D x 29½"H	45½"W x 22¾"D	H115692X	107	4.0	\$791
	42¼"W x 24"D x 29½"H	39¾"W x 22¾"D	H115691X	98	4.0	\$752
	20"D Credenza Shell (with 10" Modesty Panel)					
	72"W x 20"D x 29½"H	69½"W x 18¾"D	H115581X	124	4.6	\$852
	66"W x 20"D x 29½"H	63½"W x 18¾"D	H115582X	117	4.2	\$826
	60"W x 20"D x 29½"H	57½"W x 18¾"D	H115583X	110	3.8	\$796
	NOTES: Makes reaching wall electrical outlets quick and easy. Provides more than 18" of clearance. See pages 156-157 for optional stack-on storage.					
 <p>Not available in two-tone laminate</p>	Kneespace Clearance End Panel Kits (field installable)					
	1½"W x 11¼"D x 28⅞"H		H105098	13	0.9	\$210
	For use at either end of Valido, 10500 or 10700 Series™ 24"D Credenza Shells (with full or 10" modesty panel) or non-pedestal end of single pedestal credenzas or credenzas with lateral files.					
	1½"W x 17¼"D x 28⅞"H		H105099	11	0.8	\$220
	For use at either end of Valido, 10500 or 10700 Series™ 30"D Desk Shells or non-pedestal end of 30"D single pedestal desks.					
	Kits include: (1) support panel; European fastening hardware; flat connector bracket; joint connector bolts with sleeve nuts (for ganging credenza to adjacent worksurface); and adjustable leveling glides. Allows conversion of units currently in the field.					
	NOTES: Can be used to connect up to three 24"D credenzas or 30"D desks in line (requires 4 kits).					
	! Not designed to be used freestanding. Not designed to be used with returns, 36"D desks or desk shells.					
	SPECIFYING EXAMPLE: H105098.N					

NOTES:

- Non-handed desk, credenza, and return shells, combined with a variety of under-the-worksurface storage solutions, maximize office layout flexibility. Shells and pedestals can be reconfigured quickly and easily when user preferences or space needs change.
- Tops are abrasion- and stain-resistant laminate over extra-thick 1½" solid core high-performance particleboard; resists warping.
- "Ribbon" edge profile; shape is on all four sides.
- Cord management grommets, for routing and hiding wires and cables, are located in the tops of desk and return shells.
- Credenza shells have a cord pass-through grommet in the top center of the modesty panel.
- The narrow design of the kneespace clearance end panel kits replace full end panels to provide added kneespace.
- Adjustable hex leveling glides allow floor-standing furniture to be easily leveled; glides have ¾" adjustable range.
- Credenza Shells available with Full or 10" Modesty Panel options.
- For conference table options, see the Preside® table tops and bases in the Tables section in the 2021 Shared Spaces Pricer. Order edge option "K".
- See pages 147-148 for modular storage components.

HOW TO SPECIFY

Select Model Number H 1 1 5 4 1	Select Edge Profile See page 140 A	Select Laminate See page 140 N N
---	---	---

VALIDO® Modular Returns

GSA SIN 33721



Icon Legend on page 19

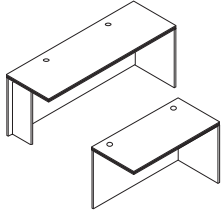

Model H115686 shown

DESCRIPTION

24" D Return Shell (with Full Modesty Panel)
 72"W x 24"D x 29½"H, (w/support; 2 grommets)
 60"W x 24"D x 29½"H, (w/support; 2 grommets)
 48"W x 24"D x 29½"H, (1 grommet)
 42"W x 24"D x 29½"H, (1 grommet)
 36"W x 24"D x 29½"H, (1 grommet)
 30"W x 24"D x 29½"H, (1 grommet)

INSIDE DIMENSIONS**MODEL****SHIP WEIGHT****CUBE****LIST PRICE**

67"W x 22¾"D	H115686	161	5.4	\$900
55"W x 22¾"D	H115684	142	4.9	\$841
47"W x 22¾"D	H11561	97	3.2	\$689
41"W x 22¾"D	H115681	97	2.5	\$674
34⅞"W x 22¾"D	H115680	91	3.2	\$674
28⅞"W x 22¾"D	H11568	78	2.8	\$625

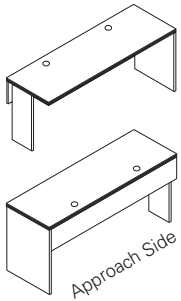
**24" D Return Shell (with 10" Modesty Panel)**

72"W x 24"D x 29½"H
 60"W x 24"D x 29½"H
 48"W x 24"D x 29½"H
 42"W x 24"D x 29½"H
 36"W x 24"D x 29½"H
 30"W x 24"D x 29½"H

67"W x 22¾"D
 55"W x 22¾"D
 47"W x 22¾"D
 41"W x 22¾"D
 34⅞"W x 22¾"D
 28⅞"W x 22¾"D

H115686X
H115684X
H11561X
H115681X
H115680X
H11568X

124
 108
 90
 80
 76
 65

5.0
 4.0
 3.0
 3.0
 3.0
 2.8

\$900
\$841
\$689
\$674
\$674
\$625

NOTES: Shells are non-handed. No pre-drilled grommet in modesty panel (field installable grommet included). Woodgrain direction on modesty/back panel runs vertical on 30"W-60"W sizes and horizontal on 72"W unit. 36"W return shell can be used to achieve an efficient 6' x 6' footprint when connected to either a 72"W x 36"D single pedestal desk, desk shell, or peninsula, or when two are connected to a 36"W corner unit model H115811. 30"W return shell can be used to accomplish a 5' x 5' footprint when connected to a 60"W x 30"D desk shell or peninsula. See pages 156-157 for optional stack-on storage.

NOTES:

- Non-handed desk, credenza, and return shells, combined with a variety of under-the-worksurface storage solutions, maximize office layout flexibility. Shells and pedestals can be reconfigured quickly and easily when user preferences or space needs change.
- Tops are abrasion- and stain-resistant laminate over extra-thick 1½" solid core high-performance particleboard; resists warping.
- "Ribbon" edge profile; shape is on all four sides.
- Cord management grommets, for routing and hiding wires and cables, are located in the tops of desk and return shells.
- Credenza shells have a cord pass-through grommet in the top center of the modesty panel.
- The narrow design of the kneespace clearance end panel kits replace full end panels to provide added kneespace.
- Adjustable hex leveling glides allow floor-standing furniture to be easily leveled; glides have ¾" adjustable range.
- Credenza Shells available with Full or 10" Modesty Panel options.
- For conference table options, see the Preside® table tops and bases in the Tables section in the 2021 Shared Spaces Pricer. Order edge option "K".
- For work-in-process paper management tools, see page 165.
- See pages 147-148 for modular storage components.

HOW TO SPECIFY**Select Model Number**

H 1 1 5 6 8 6

Select Edge Profile

See page 140

A

Select Laminate

See page 140

N N



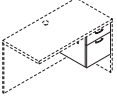
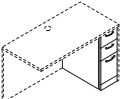
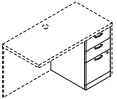
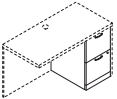

	DESCRIPTION	MODEL	SHIP WEIGHT	CUBE	LIST PRICE
 <p>Not available in two-tone laminate</p>	Box/File Pedestal (with core removable lock) 15 ⁵ / ₈ "W x 22 ³ / ₄ "D x 17 ³ / ₄ "H NOTES: For use under 24"D, 30"D and 36"D desk, credenza and return shells. Hangrails included. Lock can be positioned on either the right or left side. Attaches to underside of worksurface top. Unfinished top and back. ! Not designed to be used freestanding.	H11501	57	5.5	\$593
 <p>Not available in two-tone laminate</p>	Narrow Box/Box/File Pedestal — floor-standing 9 ¹ / ₂ "W x 22 ³ / ₄ "D x 28"H NOTES: For use under 24"D, 30"D and 36"D modular desk, credenza and return shells. Unfinished top and back. ! Handle choices for this model are the Sweep, Crescent and Arch designs only. The linear handle (options "G" and "J") is not available on this product as the width of the component interferes with lock on the drawer face. ! Not designed to be used freestanding.	H115093	61	5.6	\$756
 <p>Not available in two-tone laminate</p>	Box/Box/File Pedestal (with core removable lock) — floor-standing 15 ⁵ / ₈ "W x 22 ³ / ₄ "D x 28"H — for use under 24"D, 30"D and 36"D desk, credenza and return shells 15 ⁵ / ₈ "W x 18 ³ / ₄ "D x 28"H — for use under 20"D, 24"D, 30"D and 36"D desk, credenza and return shells NOTES: Top box drawer does not lock. Hangrails included. Unfinished top and back. ! Not designed to be used freestanding.	H11502	90	8.4	\$767
 <p>Not available in two-tone laminate</p>	File/File Pedestal (with core removable lock) — floor-standing 15 ⁵ / ₈ "W x 22 ³ / ₄ "D x 28"H — for use under 24"D, 30"D and 36"D desk, credenza and return shells 15 ⁵ / ₈ "W x 18 ³ / ₄ "D x 28"H — for use under 20"D, 24"D, 30"D and 36"D desk, credenza and return shells NOTES: Hangrails included. Unfinished top and back. ! Not designed to be used freestanding.	H11504	85	8.4	\$767
		H115014	72	7.0	\$723

NOTES:

- Pedestals can be reconfigured quickly and easily when user preferences or space needs change.
- File drawers accept hanging folders in letter or legal size.
- Narrow pedestal features a compact design that is ideal for use in U- and L-shaped layouts for smaller spaces, such as a 5' x 8' U-shaped workstation or a 5' x 5' L-shaped workstation.
- Pedestal drawers operate on full extension, ball-bearing suspensions to ensure smooth, quiet, long-lasting operation.
- Handle options shown on page 140.
- Pedestal sides are notched to enable the routing of cords and cables.
- Mobile pedestals shown on page 160, work well in a variety of configurations.
- Pedestal models ship assembled unless designated .
- Modular pedestals to be used with 24"D, 30"D and 36"D Modular Shells.
- Pedestal models not designed to be used freestanding.
- See pages 144-146 for desk, credenza and return shells.

HOW TO SPECIFY

Select Model Number 	Select Handle Option Linear handles "G" and "J" not available on model H115093 See page 140 	Select Laminate See page 140 
---	---	---

VALIDO® Laminate Modular Components

GSA SIN 33721



Icon Legend on page 19

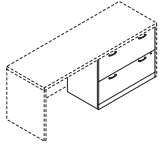

Not available in two-tone laminate

DESCRIPTION**Lateral File Pedestal (with core removable lock) — floor-standing**

36"W x 20"D x 28"H — for use under 24"D, 30"D and 36"D desk, credenza and return shells

MODEL**H11503****SHIP WEIGHT**

127

CUBE

15.6

LIST PRICE**\$1179**

NOTES: Hangrails included. **Unfinished top and back.** Mechanical interlock inhibits extension of more than one drawer at a time.

⚠ Not designed to be used freestanding.

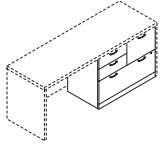

Not available in two-tone laminate

Multi File Pedestal (with core removable lock) — floor-standing

36"W x 20 1/4"D x 28"H — for use under 24"D, 30"D and 36"D desk, credenza and return shells

H11505

155

15.6

\$1406

NOTES: Versatile four drawer unit features one lateral file drawer, one vertical file drawer, and two box drawers. Box drawers do not lock. Hangrails included. **Unfinished top and back.** Mechanical interlock in lateral drawer inhibits extension of more than one drawer at a time.

⚠ Not designed to be used freestanding.

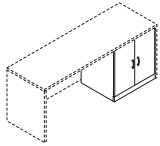

Not available in two-tone laminate

Cabinet Pedestal — floor-standing

26"W x 21 1/4"D x 28"H — for use under 24"D, 30"D and 36"D desk, credenza and return shells

H11508

78

12.2

\$855

NOTES: One adjustable shelf at 2 1/2" increments. Doors are non-locking. **Unfinished top and back.**

⚠ Not designed to be used freestanding.

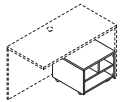
**Mobile Printer/Fax Cart**

20"W x 19 7/8"D x 14 1/8"H

H105679

52

2.9

\$420

NOTES: Holds laser printers, inkjet printers or fax machines. Ideal for limited space. Low profile cart stores conveniently and easily under desks and workstations. Interior compartment shelving is Black. Four casters. **1 1/8" thick top with flat, non-profiled edge.**

SPECIFYING EXAMPLE: H105679.NN

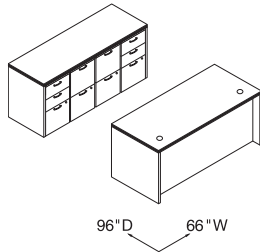

1 – H11579
1 – H11542
2 – H115102
2 – H115104

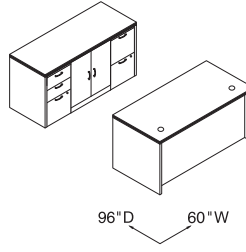

1 – H11578
1 – H11564
1 – H11502
1 – H11504
1 – H11508

NOTES:

- Pedestals can be reconfigured quickly and easily when user preferences or space needs change.
- See page 140 for handle design/finish options.
- File drawers accept hanging folders in letter or legal size.
- Pedestal drawers operate on full extension, ball-bearing suspensions to ensure smooth, quiet, long-lasting operation.
- Pedestal sides are notched to enable the routing of cords and cables.
- Mobile pedestals shown on page 160, work well in a variety of configurations.
- Pedestal models ship assembled unless designated
- See pages 144-146 for desk, credenza and return shells.

HOW TO SPECIFY**Select Model Number**

H 1 1 5 0 3

Select Handle Option

See page 140
Not specified for model H105679

C

Select Laminate

See page 140

N

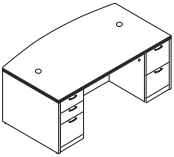
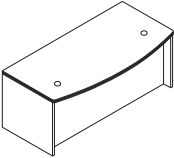
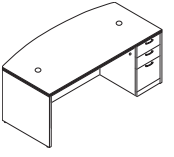
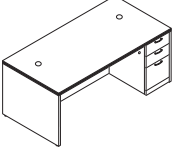

Laminate Wood Desks — Full Pedestals

	DESCRIPTION	FULL WIDTH OVERHANG	MODEL	SHIP WEIGHT	CUBE	LIST PRICE
	Double Pedestal Desk, 3/2					
	72"W x 36"D x 29½"H, Bow Top	10½"	H115899	362	52.2	\$2438
	72"W x 36"D x 29½"H, Rectangle Top	10½"	H115890	370	52.2	\$2319
	66"W x 30"D x 29½"H, Rectangle Top	4½"	H115891	312	40.9	\$2231
	60"W x 30"D x 29½"H, Rectangle Top	4½"	H115892	303	37.3	\$2119
	NOTES: All drawers lock. Two worksurface grommets to route/hide cords. See page 164 for optional center drawers. Bow top model measures 36"D at the crest and 30" along the end panels.					
	Single Pedestal Desk, Bow Top					
	72"W x 36"D x 29½"H, Right	10½"	H115893R	308	52.2	\$2139
	72"W x 36"D x 29½"H, Left	10½"	H115894L	308	52.2	\$2139
NOTES: Box/box/file drawer configuration. Drawers lock. Two worksurface grommets to route/hide cords. See page 164 for optional center drawers. Bow top model measures 36"D at the crest and 30" along the end panels.						
	Single Pedestal Desk, Rectangle Top					
	72"W x 36"D x 29½"H, Right	10½"	H115895R	316	52.2	\$2001
	66"W x 30"D x 29½"H, Right	4½"	H115897R	269	40.9	\$1818
	72"W x 36"D x 29½"H, Left	10½"	H115896L	316	52.2	\$2001
	66"W x 30"D x 29½"H, Left	4½"	H115898L	269	40.9	\$1818
NOTES: Box/box/file drawer configuration. Drawers lock. Two worksurface grommets to route/hide cords. See page 164 for optional center drawers.						

NOTES:

- Full pedestal design provides a more formal styling aesthetic and maximizes storage space.
- Drawers in pedestal extend from underside of worksurface to the floor.
- Tops are abrasion- and stain-resistant laminate over extra-thick 1½" solid core high-performance particleboard; resists warping.
- 3" round worksurface grommet can be replaced with optional Power Hub (model HGRMTAC) or Power/USB Hub (model HGRMTUSB2) to bring the ease of plug-and-play to the desktop. See page 168.
- Recessed modesty panel design facilitates conferencing. See approach side illustration at left.
- Full height modesty panels.
- Drawers operate on full extension, ball-bearing suspensions to ensure smooth, quiet, long-lasting operation.
- See page 140 for handle design/finish options.
- File drawer design includes integrated hangrails for side-to-side letter or legal filing; and front-to-back for letter filing.
- All drawers are 5-sided construction, which allows easy drawer alignment or replacement of drawer fronts.
- Desk, credenza and return models ship assembled.
- For conference table options, see the Preside® table tops and bases in the Tables section in the 2021 Shared Spaces Pricer. Order edge option "K".
- See pages 153-169 for shared components.

HOW TO SPECIFY

Select Model Number See page 140 H 1 1 5 8 9 9	Select Edge Profile See page 140 A	Select Handle Option See page 140 C	Select Laminate See page 140 N N
--	--	---	--

VALIDO®

Laminate Wood Desks — Full Pedestals

GSA SIN 33721

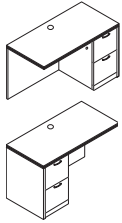

Icon Legend on page 19

**DESCRIPTION****Return, File/File**

48"W x 24"D x 29½"H, Right
42"W x 24"D x 29½"H, Right
48"W x 24"D x 29½"H, Left
42"W x 24"D x 29½"H, Left

NOTES: Return is for use with single pedestal desks, desk shells, peninsulas or corner units. Drawers lock. One worksurface grommet and one cord pass-through grommet in top center of modesty panel to reach wall electrical outlets. See pages 156-157 for optional stack-on storage.

FULL WIDTH OVERHANG**MODEL****SHIP WEIGHT****CUBE****LIST PRICE**

	H115905R	168	24.9	\$1328
	H115907R	159	20.5	\$1314
	H115906L	168	24.9	\$1328
	H115908L	159	20.5	\$1314

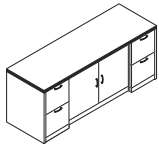
**Credenza with Doors**

72"W x 24"D x 29½"H

3½"

H115909

340

36.0

\$2428

NOTES: All drawers lock. Doors are non-locking. One cord pass-through grommet in top center of modesty panel. Includes a fixed shelf located at the bottom of the center storage area. No intermittent shelf. See pages 156-157 for optional stack-on storage.

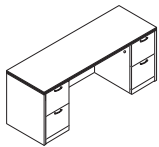
**Credenza with Kneespace — 2/0/2**

72"W x 24"D x 29½"H

3½"

H115900

296

36.0

\$2067

66"W x 24"D x 29½"H

3½"

H115901

286

31.6

\$1967

60"W x 24"D x 29½"H

3½"

H115902

257

28.8

\$1904

NOTES: All drawers lock. One cord pass-through grommet in top center of modesty panel. See pages 156-157 for optional stack-on storage.

ⓘ Not designed to be used with Valido/11500 Series 22¾"D modular or mobile pedestals. Modesty/back panel is inset 3½".

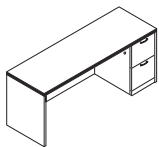
**Single Pedestal Credenza, File/File**

72"W x 24"D x 29½"H, Right (shown)

3½"

H115903R

251

36.0

\$1701

72"W x 24"D x 29½"H, Left

3½"

H115904L

251

36.0

\$1701

NOTES: Drawers lock. One cord pass-through grommet in top center of modesty panel. See pages 156-157 for optional stack-on storage.

ⓘ Not designed to be used with Valido/11500 Series 22¾"D modular or mobile pedestals. Modesty/back panel is inset 3½".

NOTES:

- Full pedestal design provides a more formal styling aesthetic and maximizes storage space.
- Drawers in pedestal extend from underside of worksurface to the floor.
- Tops are abrasion- and stain-resistant laminate over extra-thick 1½" solid core high-performance particleboard; resists warping.
- Recessed modesty panel design facilitates conferencing. See approach side illustration at left.
- Full height modesty panels.
- Drawers operate on full extension, ball-bearing suspensions to ensure smooth, quiet, long-lasting operation.
- See page 140 for handle design/finish options.
- File drawer design includes integrated hangrails for side-to-side letter or legal filing; and front-to-back for letter filing.
- All drawers are 5-sided construction, which allows easy drawer alignment or replacement of drawer fronts.
- Valido® 18¾"D modular and mobile pedestals can be positioned under credenza with kneespace and single pedestal credenza models.
- Desk, credenza and return models ship assembled.
- For conference table options, see the Preside® table tops and bases in the Tables section in the 2021 Shared Spaces Pricer. Order edge option "K".
- See pages 153-169 for shared components.

HOW TO SPECIFY**Select Model Number**

H 1 1 5 9 0 5 R .

Select Edge Profile

See page 140

A .

Select Handle Option

See page 140

C .

Select Laminate

See page 140

N N



Laminate Wood Desks – 3/4 Pedestals

	DESCRIPTION	FULL WIDTH OVERHANG	MODEL	SHIP WEIGHT	CUBE	LIST PRICE
	Double Pedestal Desk, 2-2					
	72"W x 36"D x 29½"H, Bow Top	10½"	H11595	356	52.2	\$1959
	72"W x 36"D x 29½"H, Rectangle Top	10½"	H11593	364	52.2	\$1795
	66"W x 30"D x 29½"H, Rectangle Top	4½"	H11571	304	40.9	\$1712
	60"W x 30"D x 29½"H, Rectangle Top	4½"	H11573	288	37.3	\$1615
NOTES: All drawers lock. Two worksurface grommets to route/hide cords. See page 164 for optional center drawers.						
	Single Pedestal Desk, Bow Top					
	72"W x 36"D x 29½"H, Right	10½"	H11587R	264	52.9	\$1727
	72"W x 36"D x 29½"H, Left	10½"	H11588L	264	52.9	\$1727
NOTES: Drawers lock. Two worksurface grommets to route/hide cords. See page 164 for optional center drawers. Bow top models measure 36"D at the crest and 30"D along the end panels.						
	Single Pedestal Desk, Rectangle Top					
	72"W x 36"D x 29½"H, Right	10½"	H11585R	303	52.2	\$1525
	66"W x 30"D x 29½"H, Right	4½"	H11583R	247	40.9	\$1426
	72"W x 36"D x 29½"H, Left	10½"	H11586L	303	52.2	\$1525
	66"W x 30"D x 29½"H, Left	4½"	H11584L	247	40.9	\$1426
NOTES: Drawers lock. Two worksurface grommets to route/hide cords. See page 164 for optional center drawers.						
	Small Office Desk					
	48"W x 30"D x 29½"H	4½"	H115885R	183	30.0	\$1150
NOTES: Small footprint makes this desk ideal for limited space. Drawers lock. One cord grommet in top for routing and hiding wires and cables. 3/4 length modesty panel facilitates reaching wall electrical outlets. Optional stack-on storage model H115323 maximizes storage space; see pages 156-157 for additional stack-on storage models.						
	Return, Box/File					
	48"W x 24"D x 29½"H, Right		H11515R	158	24.9	\$1110
	42"W x 24"D x 29½"H, Right		H11511R	146	20.5	\$1097
	48"W x 24"D x 29½"H, Left		H11516L	158	24.9	\$1110
	42"W x 24"D x 29½"H, Left		H11512L	146	20.5	\$1097
NOTES: Return is for use with single pedestal desks, desk shells, peninsulas or corner units. Drawers lock. One worksurface grommet and one cord pass-through grommet in top center of modesty panel to reach wall electrical outlets. See pages 156-157 for optional stack-on storage.						
❗ Not designed to be used freestanding.						
		102"D	66"W			
				H11584L		
				H11515R		
				H115327		
				H115520		
				H115523		
				HLVPM1		
		108"D	126"W			
				H11587R		
				H115598		
				H115811	H115524	
				H11516L	H115327	
				H115301	HLVPM1	

NOTES:

- For components that can be shared with Valido/11500 Series, see pages 153-169.
- Tops are abrasion- and stain-resistant laminate over extra-thick 1½" solid core high-performance particleboard; resists warping.
- 3/4 pedestal design increases budget flexibility.
- Formal, full height modesty panels.
- 3" round worksurface grommet can be replaced with optional Power Hub (model HGRMTAC) or Power/USB Hub (model HGRMTUSB2) to bring the ease of plug-and-play to the desktop. See page 168.
- All drawers are 5-sided construction, which allows easy drawer alignment or replacement of drawer fronts.
- The small footprint of the Small Office Desk is ideal for limited space.
- Drawers operate on full extension, ball-bearing suspensions to ensure smooth, quiet, long-lasting operation.
- See page 140 for handle design/finish options.
- Center drawers conveniently store writing instruments, paper and other miscellaneous items. Includes pencil tray. See page 164.
- File drawer design includes integrated hangrails for side-to-side letter or legal filing; and front-to-back for letter filing.
- Desk, credenza and return models ship assembled.
- See pages 156-157 for optional stack-on storage.
- For conference table options, see the Preside® table tops and bases in the Tables section in the 2021 Shared Spaces Pricer. Order edge option "K".

HOW TO SPECIFY

Select Model Number	Select Edge Profile	Select Handle Option	Select Laminate
See page 140	See page 140	See page 140	See page 140
H 1 1 5 9 5	A	C	N N



Icon Legend on page 19

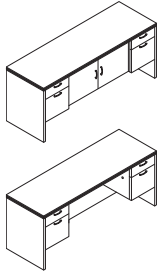

DESCRIPTION	FULL WIDTH OVERHANG	MODEL	SHIP WEIGHT	CUBE	LIST PRICE
Credenza with Doors 72"W x 24"D x 29½"H	3½"	H11544	294	36.0	\$1975
NOTES: Includes one fixed shelf at the bottom of the center storage area. All drawers lock. Doors are non-locking.					
Credenza with Kneespace 72"W x 24"D x 29½"H	3½"	H11543	259	36.0	\$1663
66"W x 24"D x 29½"H	3½"	H11566	249	31.6	\$1615
60"W x 24"D x 29½"H	3½"	H11565	239	28.8	\$1556
NOTES: One cord pass-through grommet in top center of modesty panel to reach wall electrical outlets. All drawers lock. See pages 156-157 for optional stack-on storage.					
! Not designed to be used with Valido/11500 Series 22¾"D modular or mobile pedestals. Modesty/back panel is inset 3½".					

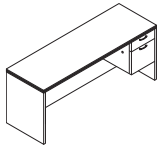

Credenza, Single Pedestal, Box/File 72"W x 24"D x 29½"H, Right (shown)	3½"	H11545R	228	36.0	\$1394
72"W x 24"D x 29½"H, Left	3½"	H11546L	228	36.0	\$1394
NOTES: One cord pass-through grommet in top center of modesty panel to reach wall electrical outlets. Drawers lock. See pages 156-157 for optional stack-on storage.					
! Not designed to be used with Valido/11500 Series 22¾"D modular or mobile pedestals. Modesty/back panel is inset 3½".					

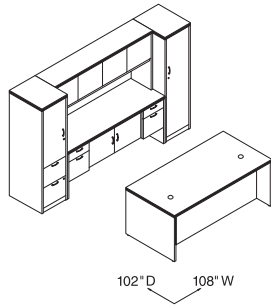

H11593
H11544
H115295R
H115298L
H11534

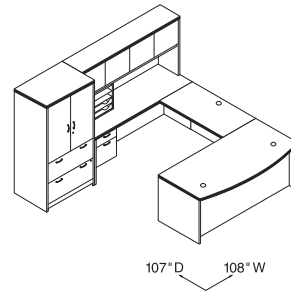

H11587R
H11570
H11546L
H11534
H115293
HLVPM1

NOTES:

- For components that can be shared with Valido/11500 Series, see pages 153-169.
- Tops are abrasion- and stain-resistant laminate over extra-thick 1½" solid core high-performance particleboard; resists warping.
- Formal, full height modesty panels.
- Cord management grommets, for routing and hiding wires and cables, are located in the tops of desks, returns, bridges and corner units.
- All drawers are 5-sided construction, which allows easy drawer alignment or replacement of drawer fronts.
- Drawers operate on full extension, ball-bearing suspensions to ensure smooth, quiet, long-lasting operation.
- See page 140 for handle design/finish options.
- File drawer design includes integrated hangrails for side-to-side letter or legal filing; and front-to-back for letter filing.
- For conference table options, see the Preside® table tops and bases in the Tables section in the 2021 Shared Spaces Pricer. Order edge option "K".

HOW TO SPECIFY

<p>Select Model Number</p> <p>H 1 1 5 4 4</p>	<p>Select Edge Profile</p> <p>See page 140</p> <p>A</p>	<p>Select Handle Option</p> <p>See page 140</p> <p>C</p>	<p>Select Laminate</p> <p>See page 140</p> <p>NN</p>
---	---	--	--

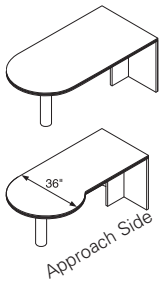

DESCRIPTION

Peninsula w/End Panel
 72"W x 36"D x 29½"H
 66"W x 30"D x 29½"H
 60"W x 30"D x 29½"H

MODEL

H11521
H11522
H11523

SHIP WEIGHT

171
 142
 119

CUBE

15.1
 11.8
 11.4

LIST PRICE

\$1082
\$988
\$918

P-shaped Peninsula w/End Panel
 72"W x 30/36"D x 29½"H, Right (shown)
 72"W x 36/30"D x 29½"H, Left

H11525R
H11526L

163
 163

13.4
 13.4

\$1203
\$1203

NOTES: Use for "U" or "L" configuration. 60"W ideal for smaller spaces. Cord routing notch in brace panel. Accept field installable modesty panel model H10528 (see page 154). See page 164 for optional center drawers. Peninsulas ship complete with end panel and support column. Support column is black.

ⓘ Not designed to be used freestanding.

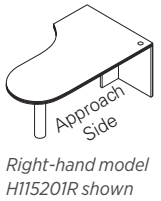

Jetty Peninsula w/End Panel
 72"W x 30/42"D x 29½"H, Right (shown)
 72"W x 42/30"D x 29½"H, Left

H115201R
H115202L

179
 179

16.9
 16.9

\$1394
\$1394

NOTES: For use in "U" or "L" configuration. Designed and sized to efficiently serve as both a computing and conferencing space. One cord management grommet in the top; cord routing notch in brace panel. Jetty units manufactured on or after 10/24/2005 accept field installable modesty panel H10528 (see page 154). Peninsulas ship complete with end panel and support column. Support column is black.

ⓘ Not designed to be used freestanding.

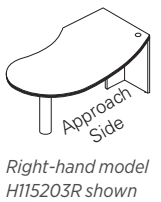
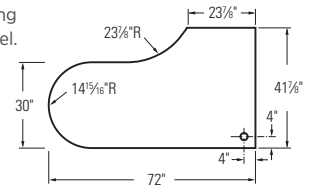

Boomerang Peninsula w/End Panel
 72"W x 30/42"D x 29½"H, Right (shown)
 72"W x 42/30"D x 29½"H, Left

H115203R
H115204L

176
 176

16.9
 16.9

\$1394
\$1394

NOTES: For use in "U" or "L" configuration. Designed and sized to efficiently serve as both a computing and conferencing space. One cord management grommet in the top; cord routing notch in brace panel. Accepts field installable modesty panel H10528 (see page 154). Peninsulas ship complete with end panel and support column. Support column is black.

ⓘ Not designed to be used freestanding.

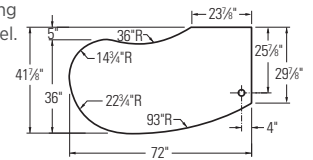

NOTES:

- Shared components shown on this page can be used with modular components shown on pages 144-148, full pedestal models shown on pages 149-150, and 3/4 pedestal models shown on pages 151-152.
- Mobile pedestals shown on page 160 work well in a variety of configurations.
- Peninsulas ship complete with end panel and black 3" diameter support column. For a silver support column option, please see model HPC191X on page 251 (ordered separately).
- Jetty, Boomerang and Rudder peninsulas are designed and sized to efficiently serve as both a computing and conferencing space.
- Adjustable hex leveling glides allow floor-standing furniture to be easily leveled; glides have 3/4" adjustable range.
- For conference table options, see the Preside® table tops and bases in the Tables section in the 2021 Shared Spaces Pricer. Order edge option "K".
- See pages 153-169 for shared components.

HOW TO SPECIFY

<p>Select Model Number</p> <p>H 1 1 5 2 1</p>	<p>Select Edge Profile</p> <p>See page 140</p> <p>A</p>	<p>Select Laminate</p> <p>See page 140</p> <p>NN</p>
--	--	---

VALIDO® Shared Components & Accessories

GSA SIN 33721



Icon Legend on page 19

**DESCRIPTION****MODEL****SHIP WEIGHT****CUBE****LIST PRICE****Field Installable Modesty Panel for Peninsulas**

50¼"W x ¾"Thick x 18"H

H10528

25

1.3

\$188

NOTES: Center drawer model H1522 can be used in conjunction with modesty panel. Laminate Modesty Panel has a cord pass-through notch in top corner.

⚠ Not designed to be used on jetty peninsulas manufactured prior to 10/24/2005.

SPECIFYING EXAMPLE: H10528.N

**Field Installable Modesty Panel for Bullet, Jetty and Boomerang Peninsulas, Frosted with Silver Frame**

50¼"W x ¾"Thick x 18"H

HPC180G

33 Ⓢ

1.5

\$694

NOTES: For use on 72"W peninsulas. Frosted/silver modesty panel HPC180G can be used with Valido, 10700, 10600 and 10500 Series™ peninsula models. Cord pass-through notch is not available on the Frosted/Silver model HPC180G. Notch is on laminate model H10528 only.

⚠ Center drawers not designed to be used with the frosted/silver modesty panel model HPC180G.

NOTES:

- Shared components shown on this page can be used with modular components shown on pages 144-148, full pedestal models shown on pages 149-150, and 3/4 pedestal models shown on pages 151-152.
- Mobile pedestals shown on page 160 work well in a variety of configurations.
- Peninsulas ship complete with end panel and black 3" diameter support column. For a silver support column option, please see model HPC191X on page 251 (ordered separately).
- Jetty, Boomerang and Rudder peninsulas are designed and sized to efficiently serve as both a computing and conferencing space.
- Adjustable hex leveling glides allow floor-standing furniture to be easily leveled; glides have ¾" adjustable range.
- For conference table options, see the Preside® table tops and bases in the Tables section in the 2021 Shared Spaces Pricer. Order edge option "K".
- See pages 153-169 for shared components.

HOW TO SPECIFY**Select Model Number**

H 1 0 5 2 8 .

Select Laminate

See page 140

N N

**DESCRIPTION****MODEL****SHIP WEIGHT****CUBE****LIST PRICE****Bridge (Single Ped. Desk, Desk Shell or Peninsula, to Corner Unit, Single Ped. Credenza or Credenza Shell)**

47"W x 24"D x 29½"H, (Clear inside depth = 21⅞"D)

H11570

86

3.2

\$505

42"W x 24"D x 29½"H, (Clear inside depth = 21⅞"D)

H11560

81

2.9

\$483

36"W x 24"D x 29½"H, (Clear inside depth = 21⅞"D) (see notes below)

H115599

69

2.9

\$483

30"W x 24"D x 29½"H, (Clear inside depth = 21⅞"D) (see notes below)

H115598

57

2.2

\$483

47"W x 20"D x 29½"H, (Clear inside depth = 17⅞"D) (see notes below)

H115699

70

3.2

\$483

42"W x 20"D x 29½"H, (Clear inside depth = 17⅞"D) (see notes below)

H115698

62

2.9

\$462

NOTES: One worksurface grommet and one grommet in top and in top center of modesty panel. Grommet can be replaced with optional Power Hub or Power/USB Hub for easy plug-and-play (see page 168). Kneespace of desk limited to 24¾"W if bridge is used with 66"W single pedestal desk. H115599 is for use with corner or extended corner units or jetty or boomerang peninsulas. H115598 is for use with corner or extended corner units. H115699 and H115698 are for use with single pedestal desks, desk shells or peninsulas (excluding jetty and boomerang).

Specify: Model.Edge.Laminate

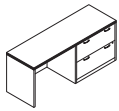
SPECIFYING EXAMPLE: H11570.A.NN**Credenza with 36" Lateral (with core removable locks)**

72"W x 24"D x 29½"H, Right (shown)

H11547R

264

36.0

\$1784

72"W x 24"D x 29½"H, Left

H11548L

264

36.0

\$1784

NOTES: Includes hangrails. Mechanical interlock inhibits the extension of more than one drawer at a time. See pages 156-157 for optional stack-on storage.

⚠ Not designed to be used with Valido/11500 Series 22¾"D modular or mobile pedestals. Modesty/back panel is inset 3½".

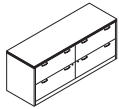
**Credenza with two Lateral Files (with core removable locks)**

72"W x 24"D x 29½"H

H115491

330

36.0

\$2500

NOTES: 4 locking drawers. Each lock secures 2 drawers. Includes hangrails; mechanical interlock inhibits the extension of more than one drawer at a time. If side-by-side drawers are opened or closed simultaneously, one drawer may interfere with the other. See pages 156-157 for optional stack-on storage.

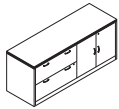
**Credenza with Lateral File, left and Storage Cabinet, right (with core removable locks)**

72"W x 24"D x 29½"H

H115492

323

36.0

\$2268

NOTES: Includes hangrails; mechanical interlock inhibits the extension of more than one drawer at a time. Storage cabinet locks and includes one adjustable interior shelf. Shelf adjusts in 1¼" increments with a total range of 5"H. See pages 156-157 for optional stack-on storage.

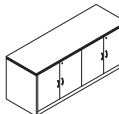
**Credenza w/Two Storage Cabinets**

72"W x 24"D x 29½"H

H115493

320

35.6

\$2013

NOTES: Each storage cabinet has one interior shelf which adjusts in 1¼" increments over a total range of 5". Each cabinet locks independently. Locks are keyed alike. For optional stack-on storage, see pages 156-157 for additional stack-on storage models.

NOTES:

- Shared components shown on this page can be used with modular components shown on pages 144-148, full pedestal models shown on pages 149-150, and 3/4 pedestal models shown on pages 151-152.
- Mobile pedestals shown on page 160 work well in a variety of configurations.
- Locking units equipped with interchangeable core removable locks.
- File drawers accept hanging folders in letter or legal size.
- See page 140 for handle design/finish options.
- Adjustable hex leveling glides allow floor-standing furniture to be easily leveled; glides have ¾" adjustable range.
- See pages 153-169 for shared components.

⚠ Keyed alike cores must be ordered separately — see page 746.

HOW TO SPECIFY

Select Model Number	Select Edge Profile	Select Handle Option	Select Laminate
See page 140	See page 140	See page 140 Not specified on Bridge models	See page 140
H 1 1 5 4 7 R .	A .	C .	N N

VALIDO®

Shared Components & Accessories

GSA SIN 33721

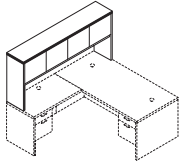

Icon Legend on page 19

**DESCRIPTION**

Stack-on Storage for an "L" Workstation
78"W x 14⁵/₈"D x 37¹/₂"H

MODEL SHIP WEIGHT CUBE LIST PRICE**H115327** 209 17.6 **\$1437**

Stack-on Storage for an "L" Workstation, Locking
78"W x 14⁵/₈"D x 37¹/₂"H

H115327K 209 17.6 **\$1520**

NOTES: Spans the total depth dimension of configurations comprised of: 48"W return or return shell attached to a 30"D single pedestal desk, desk shell or peninsula (78"D); 42"W return or return shell attached to a 36"D single pedestal desk, desk shell or peninsula (78"D). 42"W return or return shell attached to a 36" corner unit (78"D); or 42"W curved return attached to 36" curved corner unit (78"D). Use back enclosure model H105857 and tackboard model H90057 (see page 158). Use task light models HH870960, or HH870960CH (see page 559). For vertical paper manager model HLVPM1, see page 165.

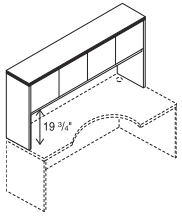
**Stack-on Storage (See page 158 for Back Enclosures and Fabric Tackboards)**

72"W x 14⁵/₈"D x 37¹/₂"H, 4 doors (Use Task Light model HH870960, see page 167)
66"W x 14⁵/₈"D x 37¹/₂"H, 4 doors (Use Task Light model HH870960, see page 167)
60"W x 14⁵/₈"D x 37¹/₂"H, 4 doors (Use Task Light model HH870960, see page 167)
48"W x 14⁵/₈"D x 37¹/₂"H, 3 doors (Use Task Light model HH870942, see page 167)
42"W x 14⁵/₈"D x 37¹/₂"H, 2 doors (Use Task Light model HH870942, see page 167)
36"W x 14⁵/₈"D x 37¹/₂"H, 2 doors (Use Task Light model HH870930, see page 167)

H11534 195 16.9 **\$1291**
H11533 184 15.3 **\$1261**
H115324 172 14.0 **\$1207**
H115323 148 11.3 **\$1049**
H115322 141 4.0 **\$903**
H115321 107 3.5 **\$865**

Stack-on Storage, Locking (See page 158 for Back Enclosures and Fabric Tackboards)

72"W x 14⁵/₈"D x 37¹/₂"H, 4 doors (Use Task Light model HH870960, see page 167)
66"W x 14⁵/₈"D x 37¹/₂"H, 4 doors (Use Task Light model HH870960, see page 167)
60"W x 14⁵/₈"D x 37¹/₂"H, 4 doors (Use Task Light model HH870960, see page 167)
48"W x 14⁵/₈"D x 37¹/₂"H, 3 doors (Use Task Light model HH870942, see page 167)
42"W x 14⁵/₈"D x 37¹/₂"H, 2 doors (Use Task Light model HH870942, see page 167)
36"W x 14⁵/₈"D x 37¹/₂"H, 2 doors (Use Task Light model HH870930, see page 167)

H11534K 195 16.9 **\$1375**
H11533K 184 15.3 **\$1345**
H115324K 172 14.0 **\$1291**
H115323K 148 11.3 **\$1112**
H115322K 141 4.0 **\$945**
H115321K 107 3.5 **\$907**

NOTES: Models H11534 and H11534K can be used for "L" configuration comprised of 30"D desk, desk shell or peninsula and 42"W return or return shell. Model H115323K has one lock which secures two of the three doors. For vertical paper manager, see page 165.

NOTES:

- Shared components shown on this page can be used with modular components shown on pages 144-148, full pedestal models shown on pages 149-150, and 3/4 pedestal models shown on pages 151-152.
- Stack-on storage models are equipped with self-closing, adjustable hinged doors and valance to hide task light.
- For work-in-process paper management tools, see page 165.
- See pages 153-169 for shared components.

❗ Removable lock core kit for stack-on and wall mount storage is model HF27B, see page 746.

❗ The HON Company is not responsible for any liabilities resulting from wall mounted storage cabinets that are not properly installed.

HOW TO SPECIFY

Select
Model Number

H 1 1 5 3 4

Select
Edge Profile

See page 140

A

Select
Laminate

See page 140

N N

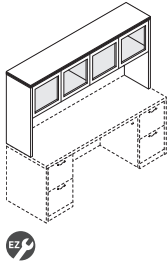

DESCRIPTION

MODEL SHIP WEIGHT CUBE LIST PRICE

Stack-on Storage for an "L" Workstation, Frosted Doors with Silver Frame

78"W x 14 5/8"D x 37 1/2"H, 4 doors (Use Task Light model HH870960, see page 167)

H115327G 210 18.4 **\$2125**

NOTES: Spans the total depth dimension of configurations comprised of: 48"W return or return shell attached to a 30"D single pedestal desk, desk shell or peninsula (78"D); 42"W return or return shell attached to a 36"D single pedestal desk or desk shell with a rectangle top, or to a peninsula (78"D). 42"W return or return shell attached to a 36" corner unit (78"D); 42"W curved return attached to 36" curved corner unit (78"D); or 36"W return shell attached to a jetty peninsula (78"D). Use back enclosure model H105857 and tackboard model H90057. Use task light models HH870960 or HH870960CH. For vertical paper manager model HLVPM1, see page 165.

Stack-on Storage, w/Frosted Doors with Silver Frame

72"W x 14 5/8"D x 37 1/2"H, 4 doors (Use Task Light model HH870960, see page 167)

H11534G 196 17.0 **\$1975**

66"W x 14 5/8"D x 37 1/2"H, 4 doors (Use Task Light model HH870960, see page 167)

H11533G 185 15.6 **\$1944**

60"W x 14 5/8"D x 37 1/2"H, 4 doors (Use Task Light model HH870960, see page 167)

H115324G 173 14.2 **\$1887**

48"W x 14 5/8"D x 37 1/2"H, 3 doors (Use Task Light model HH870942, see page 167)

H115323G 148 11.5 **\$1564**

42"W x 14 5/8"D x 37 1/2"H, 2 doors (Use Task Light model HH870942, see page 167)

H115322G 141 4.1 **\$1253**

36"W x 14 5/8"D x 37 1/2"H, 2 doors (Use Task Light model HH870930, see page 167)

H115321G 107 4.1 **\$1213**

NOTES: For respective desk, credenza or return widths. Model 11534 can be used for "L" configuration comprised of a 42"W return or return shell attached to a 30"D single pedestal desk, desk shell or peninsula (72"); 36"W return shell attached to a 36"D single pedestal desk, desk shell or peninsula (72"); or 30"W return shell attached to a jetty peninsula (72"). Back enclosures, tackboards for use with back enclosures and task lights are available as options. See vertical paper manager model HLVPM1 on page 165.

Stack-on Storage models H115327G, H11534G, H11533G and H115324G use task light model HH870960. Models H115323G and H115322G use task light model HH870942 and model H115321G uses task light model HH870930. All task lights can be found on page 167.

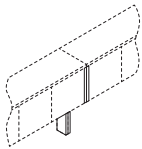

Stack-on Storage Clearance End Panel Kit

1 1/8"W x 4 5/8"-14 5/8"D x 36"H

H105349 29 3.4 **\$360**

Two field installable end panels (1-right; 1-left) for use in ganging two 10500 or Valido® Series stack-on storage units. See page 272.

NOTES: Can be used to connect up to two stack-on storage units in a line (requires 1 kit). Not available in two-tone laminate.

SPECIFYING EXAMPLE: H105349.N

NOTES:

- Shared components shown on this page can be used with modular components shown on pages 144-148, full pedestal models shown on pages 149-150, and 3/4 pedestal models shown on pages 151-152.
- Stack-on storage models are equipped with self-closing, adjustable hinged doors and valance to hide task light.
- For work-in-process paper management tools, see page 165.
- See pages 153-169 for shared components.

! Removable lock core kit for stack-on and wall mount storage is model HF27B, see page 746.

! The HON Company is not responsible for any liabilities resulting from wall mounted storage cabinets that are not properly installed.

HOW TO SPECIFY

<p>Select Model Number</p> <p>H 1 1 5 3 2 7 G .</p>	<p>Select Edge Profile</p> <p>See page 140</p> <p>A .</p>	<p>Select Laminate</p> <p>See page 140</p> <p>NN</p>
---	---	--

VALIDO®

Shared Components & Accessories

GSA SIN 33721

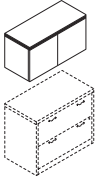

Icon Legend on page 19

**DESCRIPTION****Wall Mounted Storage Cabinet**

30"W x 14 $\frac{5}{8}$ "D x 17 $\frac{7}{8}$ "H, 2 doors
(Use Task Light model HH870930, see page 167)
36"W x 14 $\frac{5}{8}$ "D x 17 $\frac{7}{8}$ "H, 2 doors
(Use Task Light model HH870930, see page 167)
42"W x 14 $\frac{5}{8}$ "D x 17 $\frac{7}{8}$ "H, 2 doors
(Use Task Light model HH870942, see page 167)
48"W x 14 $\frac{5}{8}$ "D x 17 $\frac{7}{8}$ "H, 3 doors
(Use Task Light model HH870942, see page 167)

MODEL COM SHIP WEIGHT CUBE LIST PRICE

H115380		77	8.7	\$872
H115381		92	10.2	\$918
H115382		103	11.7	\$988
H115383		121	14.0	\$1067

Wall Mounted Storage Cabinet, Locking

30"W x 14 $\frac{5}{8}$ "D x 17 $\frac{7}{8}$ "H, 2 doors
(Use Task Light model HH870930, see page 167)
36"W x 14 $\frac{5}{8}$ "D x 17 $\frac{7}{8}$ "H, 2 doors
(Use Task Light Model HH870930, see page 167)
42"W x 14 $\frac{5}{8}$ "D x 17 $\frac{7}{8}$ "H, 2 doors
(Use Task Light Model HH870942, see page 167)
48"W x 14 $\frac{5}{8}$ "D x 17 $\frac{7}{8}$ "H, 3 doors
(Use Task Light Model HH870942, see page 167)

H115380K		77	8.7	\$914
H115381K		92	10.2	\$960
H115382K		103	11.7	\$1030
H115383K		121	14.0	\$1130

NOTES: Horizontal interlocking rails are included; due to varying types of walls, installers are responsible for selecting and supplying the appropriate fasteners. Tackboard widths differ slightly from wall mounted storage cabinet widths. For applications where multiple wall mounted storage cabinets are placed side-by-side, the preferred tackboard solution may be to utilize a larger tackboard size. For example, H90057 = 75"W; H90056 = 68 $\frac{3}{4}$ "W; H90055 = 62 $\frac{3}{4}$ "W; H90054 = 56 $\frac{3}{4}$ "W. For paper organizer tools, see page 165.

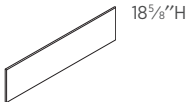

Not available in two-tone laminate

Back Enclosure for Stack-on Storage

75 $\frac{3}{4}$ "W - for 78"W model #H115327
69 $\frac{3}{4}$ "W - for 72"W model #H11534
63 $\frac{3}{4}$ "W - for 66"W model #H11533
57 $\frac{3}{4}$ "W - for 60"W model #H115324
45 $\frac{3}{4}$ "W - for 48"W model #H115323
39 $\frac{3}{4}$ "W - for 42"W model #H115322
33 $\frac{3}{4}$ "W - for 36"W model #H115321

H105857		39	1.4	\$259
H105856		33	1.3	\$237
H105855		31	1.3	\$221
H105854		29	1.3	\$211
H105853		23	0.9	\$211
H105852		21	0.9	\$201
H105851		18	0.9	\$190

NOTES: Non-tackable. Specify laminate.

SPECIFYING EXAMPLE: H105857.N

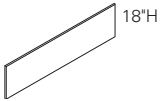
**Tackboards for use with Stack-on Back Enclosures**

75"W - for 78"W model #H115327 Hutch with #H105857 Enclosure
68 $\frac{3}{4}$ "W - for 72"W model #H11534 Hutch with #H105856 Enclosure
62 $\frac{3}{4}$ "W - for 66"W model #H11533 Hutch with #H105855 Enclosure
56 $\frac{3}{4}$ "W - for 60"W model #H115324 Hutch with #H105854 Enclosure
44 $\frac{3}{4}$ "W - for 48"W model #H115323 Hutch with #H105853 Enclosure
39"W - for 42"W model #H115322 Hutch with #H105852 Enclosure
33"W - for 36"W model #H115321 Hutch with #H105851 Enclosure

H90057	3.0	13	3.2	\$317
H90056	2.0	12	2.7	\$301
H90055	2.0	11	2.5	\$286
H90054	2.0	10	2.2	\$252
H90053	2.0	8	1.8	\$242
H90052	2.0	7	1.6	\$223
H90051	1.0	6	1.4	\$196

NOTES: Specify fabric, see pages 25-26. Upcharges may apply to premium fabric grades.

❗ Disperse (DISP) fabric not available on sizes wider than 60". Analog (ANLG) and Exchange (EXG) not available on sizes wider than 72".

❗ Back Enclosures must be ordered separately.

SPECIFYING EXAMPLE: H90057.APN15

NOTES:

- Shared components shown on this page can be used with modular components shown on pages 144-148, full pedestal models shown on pages 149-150, and 3/4 pedestal models shown on pages 151-152.
- Back enclosure features full-width 1 $\frac{1}{8}$ " slot at the bottom to facilitate routing cords and reaching wall electrical outlets.
- Tackboard is sized $\frac{3}{4}$ " narrower than stack-on storage back enclosure, allowing $\frac{3}{8}$ " on each side to route task light cord.
- Wall mounted storage cabinet attachment requires individual cabinets be secured by a minimum of two wall mounting locations/studs.
- Wall mounted storage cabinets are designed for interior and perimeter walls that are constructed with wood or metal studs.
- Wall attachment methodology: horizontally mounted, interlocking brackets.
- Wall mounted storage cabinet door design overlaps end panels so that when multiple units are placed side-by-side they appear as one continuous unit.
- See pages 153-169 for shared components.

❗ Removable lock core kit for stack-on and wall mount storage is model HF27B, see page 746.

❗ The HON Company is not responsible for any liabilities resulting from wall mounted storage cabinets that are not properly installed.

HOW TO SPECIFY

Select
Model Number

H 1 1 5 3 8 0 .

Select
Edge Profile

See page 140

A .

Select
Laminate

See page 140

N N

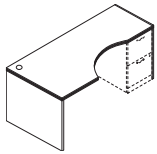

Right-hand model
H115815R shown

DESCRIPTION

Extended Corner Unit

24"W x 36"D x 72"W x 24"D x 29½"H, Right (shown)
24"D x 72"W x 36"D x 24"W x 29½"H, Left

MODEL SHIP WEIGHT CUBE LIST PRICE

H115815R 203 7.0 **\$1308**
H115816L 203 7.0 **\$1308**

NOTES: Can be used freestanding. One grommet in top and in modesty panel. Accept Valido/11500 Series modular or mobile pedestals. See pages 156-157 for optional stack-on storage.

ⓘ Designed to be used with returns or bridges.

SPECIFYING EXAMPLE: H115815R.A.NN

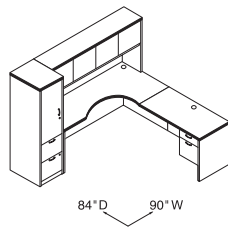
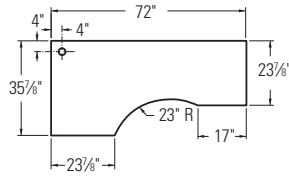

H115298L
H115816L
H11534
H11515R

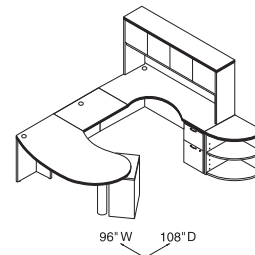

H115103
H115204L
H115598
H115815R
H115104
H11534
H115520

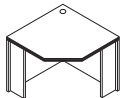

Corner Unit

24" x 36" x 36" x 24" x 29½"H

H115811 141 3.1 **\$902**

NOTES: Can be used freestanding.

ⓘ Designed to be used with 24"D x 29½"H returns or bridges.

SPECIFYING EXAMPLE: H115811.A.NN

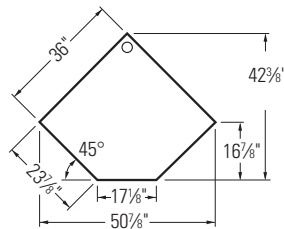

NOTES:

- Shared components shown on this page can be used with modular components shown on pages 144-148, full pedestal models shown on pages 149-150, and 3/4 pedestal models shown on pages 151-152.
- Mobile pedestals, shown on page 160, work well in a variety of configurations.
- Extended corner units (H115815R and H115816L) can be used with 36"W return shell (H115680) to achieve a 6' x 6' layout.
- 36" corner unit (H115811) can be used with two 36"W return shells (H115680) to achieve a 6' x 6' layout.
- For conference table options, see the Preside® table tops and bases in the Tables section in the 2021 Shared Spaces Pricer. Order edge option "K".
- For work-in-process paper management tools, see page 165.
- See pages 153-169 for shared components.

HOW TO SPECIFY

<p>Select Model Number</p> <p>H 1 1 5 8 1 7 R .</p>	<p>Select Edge Profile</p> <p>See page 140</p> <p>A .</p>	<p>Select Laminate</p> <p>See page 140</p> <p>NN</p>
--	--	---









VALIDO®

Shared Components & Accessories

GSA SIN 33721

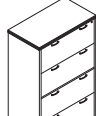

Icon Legend on page 19

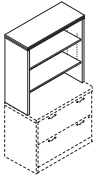
	DESCRIPTION	MODEL	SHIP WEIGHT	CUBE	LIST PRICE
	Mobile Pedestal (with core removable lock) — Box/Box/File 15 ³ / ₄ "W x 22 ³ / ₄ "D x 28 ³ / ₈ "H — use freestanding or under 24"D, 30"D and 36"D modular shells NOTES: Top box drawer does not lock.	H115102	121	8.4	\$939
	Mobile Pedestal (with core removable lock) — File/File 15 ³ / ₄ "W x 22 ³ / ₄ "D x 28 ³ / ₈ "H — use freestanding or under 24"D, 30"D and 36"D modular shells	H115104	121	8.4	\$939
	Mobile Pedestal (with core removable lock) — Box/File 15 ³ / ₄ "W x 18 ³ / ₄ "D x 21 ¹ / ₈ "H — use freestanding or under 20"D, 24"D, 30"D and 36"D modular shells	H115106	68	5.8	\$786
	Mobile Pedestal — Shelf/Box/File 15 ³ / ₄ "W x 18 ³ / ₄ "D x 28 ³ / ₈ "H — use freestanding or under 20"D, 24"D, 30"D and 36"D modular shells NOTES: All mobile pedestals have a 1 ¹ / ₈ " thick top with flat, non-profiled edge. SPECIFYING EXAMPLE: H115102.C.NN	H115109	76	7.3	\$863
	Lateral File (with core removable lock) 36"W x 24"D x 29 ¹ / ₂ "H — two drawer 36"W x 20"D x 29 ¹ / ₂ "H — two drawer 36"W x 20"D x 45 ¹ / ₂ "H — three drawer 36"W x 20"D x 59 ¹ / ₈ "H — four drawer NOTES: Includes hangrails, mechanical interlock, and in H11563 and H115690, a counterweight. Stack-on storage (H115321) and bookcase hutch (H115292) can be used with H11563 and H115690. Interlock inhibits the extension of more than one drawer from opening at a time. 24"D two-drawer model aligns with the depth of 24"D credenzas and returns. SPECIFYING EXAMPLE: H11563.A.C.NN	H115690	199	18.4	\$1316
		H11563	177	15.6	\$1253
		H11517	247	23.2	\$1904
		H11516	312	31.0	\$2654
	Storage Cabinet with Doors (with core removable lock) 36"W x 24"D x 29 ¹ / ₂ "H 36"W x 20"D x 29 ¹ / ₂ "H NOTES: Includes one adjustable shelf. Shelf adjusts in 1 ¹ / ₄ " increments with a total range of 5"H. Stack-on storage (H115321) and bookcase hutch (H115292) can be used with H115290 or H115291. 24"D model aligns with the depth of 24"D credenzas and returns. SPECIFYING EXAMPLE: H115291.A.C.NN	H115290	176	18.4	\$1132
		H115291	154	15.0	\$972
	Bookcase Hutch (for use with lateral file models H11563 or H115690 or storage cabinet with door models H115291 or H115290) 36"W x 14 ³ / ₈ "D x 37 ¹ / ₂ "H NOTES: Cord pass-through gap behind shelves and a 1 ¹ / ₈ "H full-width cord management slot at the bottom of the back panel to facilitate routing cords and reaching wall electrical outlets. When placed on top of 29 ¹ / ₂ "H base unit the total height (67"H) matches the height of credenzas with stack-on storage and the height of the wardrobe/storage cabinets and storage cabinet/lateral file. Two shelves are adjustable in 1 ¹ / ₄ " increments with a total range of 17 ¹ / ₂ "H. SPECIFYING EXAMPLE: H115292.A.NN	H115292	108	3.8	\$758

NOTES:

- For additional components that can be shared with Valido/11500 Series, see pages 153-169.
- Drawers operate on full extension, ball-bearing suspensions to ensure smooth, quiet, long-lasting operation.
- Versatile mobile pedestals work well in a variety of configurations. Can be used freestanding or under modular shells. 1¹/₈" thick top with a square, non-profiled edge.
- 24"D two drawer lateral file and 24"D storage cabinet with door models align with 24"D credenzas and returns, credenza and return shells as well as wardrobe/storage cabinets to provide linear layout continuity.
- Mobile printer/fax cart shown on page 148 is ideal for limited space.
- File drawer design includes integrated hangrails for side-to-side letter or legal filing; and front-to-back for letter filing.
- Adjustable hex leveling glides allow floor-standing furniture to be easily leveled; glides have 3/4" adjustable range.
- For conference table options, see the Preside® table tops and bases in the Tables section in the 2021 Shared Spaces Pricer. Order edge option "K".

HOW TO SPECIFY**Select Model Number**

H 1 1 5 6 3 .

Select Edge Profile

See page 140

Not specified for models H115102, H115103 and H115104

A .

Select Handle Option

See page 140

Not specified for models H115292, H115520, H115523 and H115524



C .

Select Laminate

See page 140

N N

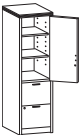

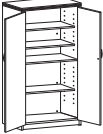
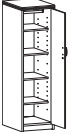
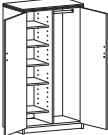
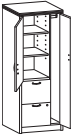
	DESCRIPTION	MODEL	SHIP WEIGHT	CUBE	LIST PRICE
 Right-hand model H115297R shown	Storage/File Cabinet (with core removable locks) 18"W x 24"D x 67"H, Hinged Right (shown)	H115297R	262	22.7	\$2055
	18"W x 24"D x 67"H, Hinged Left	H115298L	262	22.7	\$2055
NOTES: Versatile unit features a storage cabinet and two file drawers. Storage cabinet includes three shelves, two are adjustable in 2½" increments. Door hinged left or right models available. File drawers operate on ball-bearing suspensions with full extension. File drawers have high sides to accept hanging folders in letter or legal size. Drawers standard with hangrails. Both the storage cabinet and the file drawers are equipped with an interchangeable core removable lock. Unit height is designed to match credenza or return plus stack-on storage height.					
 Doors open 110 degrees from closed position.	Storage Cabinet/Lateral File (with core removable lock) 36"W x 24"D x 67"H	H115293	373	41.0	\$2665
	NOTES: Storage cabinet is standard with one fixed and two full-width adjustable shelves in top compartment; adjustable shelves can be removed. Overall storage compartment measures 31¼"W x 22"D x 36½"H and will accommodate supplies, books and binders, as well as business machines and electronic equipment. Cord pass-through gap behind shelves and grommet in back of cabinet to facilitate routing cords and reaching wall electrical outlets. Two drawer lateral file on bottom. Lateral file comes with mechanical interlock and hangrails. Cabinet and lateral file lock independently. Unit height is designed to match credenza or return plus stack-on storage height.				
 Doors open 110 degrees from closed position.	Storage Cabinet w/Doors (with core removable lock) 36"W x 24"D x 67"H	H115299	349	41.0	\$2381
	NOTES: Large capacity storage area includes five, full-width (side-to-side) shelves; three are adjustable in 2½" increments. Unit height matches credenza or return plus stack-on storage height.				
 Right-hand model H115295R shown	Personal Wardrobe/Storage Cabinet (with core removable lock) 18"W x 24"D x 67"H, Hinged Right (shown)	H115295R	227	22.9	\$1777
	18"W x 24"D x 67"H, Hinged Left	H115296L	227	22.9	\$1777
NOTES: Unit is standard with four adjustable shelves, coat rod, and core removable lock. Shelves adjust in 2½" increments. Unit height is designed to match credenza or return plus stack-on storage height. Cabinet can be used as a wardrobe by removing four adjustable shelves. Coat rod can be removed from cabinet for storage only applications.					
 Doors open 110 degrees from closed position.	Personal Wardrobe/Storage Cabinet (with core removable lock) 36"W x 24"D x 67"H	H11530	349	41.0	\$2603
	NOTES: Spacious design is standard with four adjustable shelves (one shelf is fixed), coat rod and core removable lock which locks both doors. Shelves adjust in 2½" increments. Unit height is designed to match credenza or return plus stack-on storage height.				
 Right-hand model H115301R shown	Personal Storage Tower (with core removable locks) 24"W x 24"D x 67"H, Wardrobe Hinged Right, Storage Cabinet Hinged Left (shown)	H115301R	304	27.9	\$2603
	24"W x 24"D x 67"H, Wardrobe Hinged Left, Storage Cabinet Hinged Right	H115302L	304	27.9	\$2603
NOTES: Spacious design includes a wardrobe closet, storage cabinet, and two file drawers in one compact unit. Wardrobe closet contains a coat rod. Storage cabinet includes three shelves, two are adjustable in 2½" increments. Door hinged left or right models available. File drawers operate on ball-bearing suspensions with full extension. File drawers have high sides to accept hanging folders in letter or legal size. Drawers standard with hangrails. Equipped with interchangeable core removable locks. Upper lock secures storage cabinet and wardrobe closet doors; lower lock secures file drawers. Unit height is designed to match credenza or return plus stack-on storage height.					

NOTES:

- Adjustable hex leveling glides allow floor-standing furniture to be easily leveled; glides have ¾" adjustable range.
- Locking units equipped with interchangeable core removable locks.
- For conference table options, see the Preside® table tops and bases in the Tables section in the 2021 Shared Spaces Pricer. Order edge option "K".
- See pages 153-169 for shared components.

🔑 Keyed alike cores must be ordered separately — see model HF23B on page 746.

HOW TO SPECIFY

Select Model Number	Select Edge Profile	Select Handle Option	Select Laminate
See page 140	See page 140	See page 140	See page 140
H 1 1 5 2 9 7 R .	A .	C .	N N

VALIDO®

Shared Components & Accessories

GSA SIN 33721



Icon Legend on page 19



H11552 shown

DESCRIPTION**Bookcase**

36"W x 13¹/₈"D x 29⁵/₈"H, 2-Shelf
 36"W x 13¹/₈"D x 43³/₈"H, 3-Shelf
 36"W x 13¹/₈"D x 57¹/₈"H, 4-Shelf
 36"W x 13¹/₈"D x 71"H, 5-Shelf

MODEL**SHIP WEIGHT****CUBE****LIST PRICE****H11552**

94

10.2

\$651**H11553**

126

15.6

\$762**H11554**

160

20.3

\$907**H11555**

191

25.3

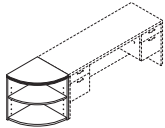
\$1023NOTES: Fixed shelves. Inside shelf dimensions on all units is 33³/₄"W x 12"D x 13"H. No assembly required.**SPECIFYING EXAMPLE: H11552.A.NN****End Cap Bookshelf**24"W x 24"D x 29¹/₂"H**H115520**

87

2.6

\$763(2 shelves, 1 fixed, 1 adjustable. Adjusts in 2¹/₂" increments with a total range of 10"H)

NOTES: Unit is freestanding. Designed to be positioned at the end of 24"D credenzas and returns. Holds books and personal items.

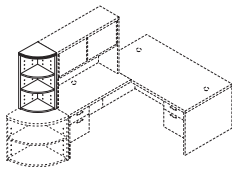
SPECIFYING EXAMPLE: H115520.A.NN**End Cap Bookshelf**15"W x 15"D x 37¹/₂"H**H115523**

54

2.2

\$675(3 shelves, 1 fixed, 2 adjustable. Adjusts in 2¹/₂" increments with a total range of 25"H)

NOTES: Unit is designed to be positioned at the end of stack-on storage and on top of model H115520. Combined height of models H115520 and H115523 matches credenza plus stack-on storage height. Can be used freestanding.

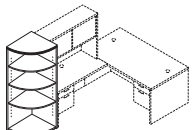
SPECIFYING EXAMPLE: H115523.A.NN**End Cap Bookshelf**

24"W x 24"D x 67"H

H115524

167

4.8

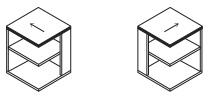
\$1213NOTES: Designed to be positioned at the end of 24"D credenzas with stack-on storage, 24"D returns with stack-on storage, 24"D storage/file cabinet, 24"D storage cabinet/lateral file, 24"D wardrobe/storage cabinets, or the 24"D personal storage tower. Unit has four shelves, three are adjustable in 2¹/₂" increments, with a total range of 45"H; bottom shelf is fixed.**SPECIFYING EXAMPLE: H115524.A.NN**

Model H115525R Model H115526L

**Square End Cap Bookshelf — 2-Fixed Shelves**24"W x 24"D x 29¹/₂"H, Right**H115525R**

98

3.7

\$75224"W x 24"D x 29¹/₂"H, Left**H115526L**

98

3.7

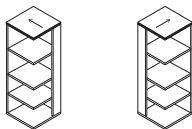
\$752**SPECIFYING EXAMPLE: H115525R.A.NN**

Model H115527R Model H115528L

**Square End Cap Bookshelf — 4-Fixed Shelves**

24"W x 24"D x 67"H, Right

H115527R

178

11.4

\$1161

24"W x 24"D x 67"H, Left

H115528L

178

11.4

\$1161**SPECIFYING EXAMPLE: H115527R.A.NN**

NOTES: Units are freestanding. Designed to be positioned next to 24"D models or as a corner bookcase.

End cap, left: grain direction on top aligns with grain direction on tops of left pedestal returns and left credenza models or when positioned to the left side of credenzas with doors or kneespace models.

End cap, right: grain direction on top aligns with grain direction on tops of right pedestal returns and right credenza models or when positioned to the right side of credenzas with doors or kneespace models.

NOTES:

- Choose from square or rounded versions of the end cap bookshelves.
- End cap bookshelf units are ideal for books, photos and mementos.
- End Cap Bookcases are designed to be positioned at the end of 24"D credenzas and returns.
- Adjustable hex leveling glides allow floor-standing furniture to be easily leveled; glides have 3/4" adjustable range.
- End cap bookshelf units are ideal for books, photos and mementos.
- For conference table options, see the Preside® table tops and bases in the Tables section in the 2021 Shared Spaces Pricer. Order edge option "K".
- See pages 153-169 for shared components.

HOW TO SPECIFY**Select Model Number**

H 1 1 5 5 2 7 R .

Select Edge Profile

See page 140

A .

Select Laminate

See page 140

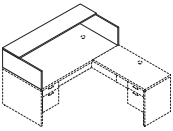
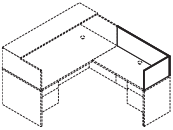
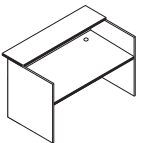
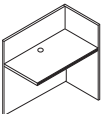
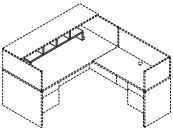

N N

	DESCRIPTION	MODEL	SHIP WEIGHT	CUBE	LIST PRICE
	Reception Station with Transaction Counter for 72"W x 36"D Desk, or Desk Shell, with rectangle top 72"W x 36"D x 14 ⁵ / ₈ "H	H115720	100	3.0	\$725
	NOTES: For desk tops without grommets, see field installable grommet kit, model HFLDGRMT or HFLDGRMT3 on page 167. Transaction counter organizer (HTCOL52) fits under/inside of transaction counter (see below).				
	Reception Station for 42"W x 24"D Return or Return Shell 42"W x 24"D x 13"H	H105722	21	1.0	\$253
	Reception Station for 48"W x 24"D Return or Return Shell 48"W x 24"D x 13"H	H105721	25	3.6	\$288
	NOTES: For return tops without grommets, see field installable grommet kit, model HFLDGRMT or HFLDGRMT3 on page 167. ⚠ Not available in two tone laminate.				
	Reception Desk Shell 72"W x 39 ⁷ / ₈ "D x 44 ¹ / ₈ "H	H115724	328	16.8	\$1452
	NOTES: Non-handed design. Integrated 18 ⁵ / ₈ "D transaction counter with a 4" full-width overhang. Two cord management grommets in top for routing and hiding wires and cables. Transaction counter organizer (HTCOL52) fits under/inside of transaction counter.				
	Reception Return Shell 42"W x 24"D x 43 ⁵ / ₈ "H	H115726	140	16.8	\$943
	NOTES: Non-handed design. Attaches to reception desk shell to form an L-shaped workstation. One cord management grommet in top for routing and hiding wires and cables. Woodgrain on approach side is vertical to match grain direction on end panels of reception desk.				
	Transaction Counter Organizer 48 ³ / ₄ "W x 11 ¹ / ₈ "D x 13"H	HTCOL52	24	1.1	\$283
	NOTES: Fits under reception station with transaction counter model H115720 or reception desk shell H115724. ⚠ Black only.				

NOTES:

- Two welcoming reception station designs to choose from — stack-on enclosure or full-to-floor shell.
- See pages 153-169 for shared components.

HOW TO SPECIFY

Select Model Number 	Select Edge Profile See page 140 	Select Laminate See page 140 
---	---	---

VALIDO® Shared Components & Accessories

GSA SIN 33721 EXCEPT AS NOTED



Icon Legend on page 19

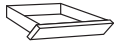

Refer to page 106 for Center Drawer compatibility information



DESCRIPTION

Angled Wood Center Drawer

26" x 15³/₈"
22" x 15³/₈"

MODEL

H1526
H1522

SHIP WEIGHT

12.0 **Ⓢ**
11.0 **Ⓢ**

CUBE

1.2
1.1

LIST PRICE

\$198
\$184

NOTES: Specify laminate for drawer. For additional information see the Workplace Tools section in the 2021 Shared Spaces Pricer.

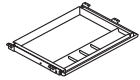

OPEN MARKET

Polymer Center Drawer

- Color: Black.
- Material: ABS.
- Minimum clearance for mounting: 23"W x 16¹/₄"D x 2"H.
- Retracts on 16" ball-bearing slides.
- Can be used on worksurfaces with Coordinate™ Height Adjustable Bases as long as it is attached with spacer model HKBS.
- Can store up to 25 lbs.

! Black finish only, no specification needed.

HCD1

7.0

0.5

\$111

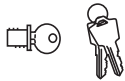

Black Removable Lock Core Kit — see page 746.

NOTES: Lock with a removable cylinder that can be interchanged as needed; allows users to access all furniture pieces in an office with a single key for convenience and security. Makes re-keying quick and easy. For use in all Valido® Series product lock cores, except the stack-on and wall mounted storage "K" models. For the latter, use lock core kit model HF27B.

HF23B

0.1 **Ⓢ**

0.1

\$32

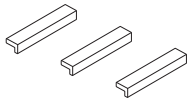

Field Installable Drawer/Door Handle Kits (fit Valido® 96mm hole spacing)

Linear, Black, 2-pack
Linear, Matte Chrome, 2-pack

HLINEARA2
HLINEARC2

0.4 **Ⓢ**
0.4 **Ⓢ**

0.3
0.3

\$56
\$56

Linear, Black, 3-pack
Linear, Matte Chrome, 3-pack

HLINEARA3
HLINEARC3

0.5 **Ⓢ**
0.5 **Ⓢ**

0.3
0.3

\$64
\$64

NOTES: The Linear and Arch handles attach using the same 96mm hole spacing as the Valido® Sweep and Crescent handles. The Linear handle is not recommended for use on the Valido® Narrow/Box/Box/File Modular Pedestal — model H115093.

Arch, Black, 2-pack
Arch, Matte Chrome, 2-pack

HARCHA2
HARCHC2

0.4 **Ⓢ**
0.4 **Ⓢ**

0.3
0.3

\$56
\$56

Arch, Black, 3-pack
Arch, Matte Chrome, 3-pack

HARCHA3
HARCHC3

0.5 **Ⓢ**
0.5 **Ⓢ**

0.3
0.3

\$64
\$64

! Must be ordered with a configurable end product. If ordered separately, not on GSA contract.

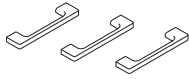

DESCRIPTION

Slide-Away Keyboard Platform (Specify: Laminate)
Extended Tray Slide-Away Keyboard Platform (Specify: Laminate)
Metal Keyboard and Mouse Tray (Specify paint)
Metal Keyboard Tray (Specify paint)

MODEL

H4022
HE4022
H4028 OPEN MARKET
H4029 OPEN MARKET

SHIP WEIGHT CUBE

10 **Ⓢ** 0.6
12 **Ⓢ** 0.7
11 **Ⓢ** 1.5
11 **Ⓢ** 1.5

LIST PRICE BY PAINT GRADE

P1 P2
\$213 \$302
\$153 \$163
\$138 \$148

NOTES: For additional information see the Workplace Tools section in the 2021 Shared Spaces Pricer.



Refer to the Workplace Tools section in the 2021 Shared Spaces Pricer for additional product information



NOTES:

- Linear and Arch field installable handles attach using Valido® 96mm (approx. 3³/₄"") hole spacing. No drilling required.
- Center drawers ideal for pens, pencils and other miscellaneous storage. Feature ball-bearing slide suspension.
- For conference table options, see the Preside® table tops and bases in the Tables section in the 2021 Shared Spaces Pricer. Order edge option "K".

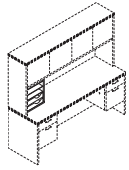

Not available in two-tone laminates

DESCRIPTION**Vertical Paper Manager**14⁷/₈"W x 10⁷/₈"D x 19¹/₁₆"H**MODEL****HLVPM1****SHIP WEIGHT**

27

CUBE

2.8

LIST PRICE**\$327**

NOTES: Keeps papers, files, and books neatly organized and within easy reach from a seated position. Designed for desk, credenza, and return tops. Fits under stack-on storage models. Two pullout drawers and three fixed shelves. Not available in pattern laminate colors. Ships fully assembled. For additional information see the Workplace Tools section in the 2021 Shared Spaces Pricer.

! When used in conjunction with wall mounted storage cabinets, the top of the wall mounted storage cabinets must be positioned a minimum of 68³/₈" above the floor.

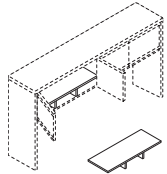
SPECIFYING EXAMPLE: HLVPM1.N**Stacked Paper Management**32¹/₂"W x 12⁵/₈"D x 4¹/₄"H**HLVPM2**

22

1.25

\$163

NOTES: Segments and organizes stack-on and wall mount storage compartments, as well as bookcase shelves. Unit can be used in Models H115327, H11534, H115322, H115321, H115382 and H115381. In some cases, installation may require removing the stack-on or wall mount storage doors. For additional information see the Workplace Tools section in the 2021 Shared Spaces Pricer.

! Black (P) only.

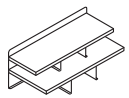

Not available in two-tone laminate

**Desktop Storage Terrace**26¹/₂"W x 12¹/₂"D x 10¹/₂"H**HLDST1**

24

1.1

\$306

NOTES: Keeps work-in-process, priority files, loose pages, and mail neatly organized and in view. Mixed material design comprised of sturdy laminate shelves with metal back and support panels. Not available in two-tone laminate combination or pattern laminate colors. Choose from Platinum Metallic (TI), Black (P), and Charcoal (S) for the metal components.

Sized to fit in stack-on and wall mounted storage cabinets in 10500, 10700, Valido, 94000, and 38000 Series. Fits in Voi stack-on and overhead cabinets except for 48"W or smaller sliding door models. For additional information see the Workplace Tools section in the 2021 Shared Spaces Pricer.

Specify: Model.Laminate.Paint

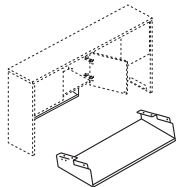
SPECIFYING EXAMPLE: HLDST1.N.TI**Hanging Paper Shelf**28¹/₁₆"W x 11⁷/₁₆"D x 4⁵/₁₆"H**HHPS1**

7

2.9

\$198

NOTES: Maximizes worksurface space; de-clutters desktop while placing priority communications and active project folders within easy reach. Angled design allows contents to be distinguished at a glance. Mixed material styling features strong painted metal frame with a frosted shelf.

Attaches quickly and easily to stack-on and wall mount storage models in the following series: 10500, 10700, Valido, 94000, and Voi (except the 36"W overhead hutch with O-legs or panel mount brackets). Not for use with 38000 Series.

For additional information see the Workplace Tools section in the 2021 Shared Spaces Pricer.

Specify: Model.Paint

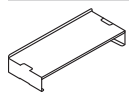
SPECIFYING EXAMPLE: HHPS1.TI**Desktop Paper Shelf**28¹/₁₆"W x 11⁵/₁₆"D x 5"H**HDPS1**

7

2.9

\$198

NOTES: Organizer shelf provides a place and space for work-in-process and piling to keep worksurfaces neat and tidy. Convenient, scalable design with interlocking side supports allow two units to be stacked and integrated. Durable painted metal frame with a frosted shelf; mixed material styling matches hanging paper shelf.

Can also be used inside select overhead storage, including the following stack-on with hinged door models: 10500 and Valido 36", 42", 66", 72", 78"W and 10700 68⁵/₈"W.

For additional information see the Workplace Tools section in the 2021 Shared Spaces Pricer.

Specify: Model.Paint

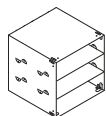
SPECIFYING EXAMPLE: HDPS1.TI**Storage Cube**

12"W x 12"D

HLSL1212

1

0.3

\$294**SPECIFYING EXAMPLE: HLSL1212.P8S****HOW TO SPECIFY**

Select
Model Number

H L V P M 1 .

Select
Laminate

See page 140

N

VALIDO® Shared Components & Accessories

OPEN MARKET EXCEPT AS NOTED

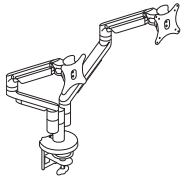

Icon Legend on page 19

**DESCRIPTION****Dual Dynamic Monitor Arm**

- 150° of rotation at base with optional 360° rotation.
- Arms extend 22" and retract up to 3".
- Monitor mount rotates 180° and tilts +/-30°.
- Monitor can be rotated from landscape to portrait position.

! Arms hold monitors from 6.2-18 lbs. Optional counterweight HPACW available to support monitors as low as 5 lbs. (see the Workplace Tools section in the 2021 Shared Spaces Pricer).

MODEL**HMASD****SHIP WEIGHT**

17.0

CUBE

1.1

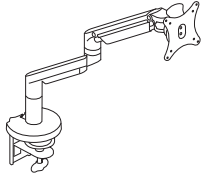
LIST PRICE**\$900****Single Dynamic Monitor Arm**

- 180° of rotation at base with optional 360° rotation.
- Arms extend 22" and retract up to 3".
- Monitor mount rotates 180° and tilts +/-30°.
- Monitor can be rotated from landscape to portrait position.

! Arms hold monitors from 6.2-18 lbs. Optional counterweight HPACW available to support monitors as low as 5 lbs. (see the Workplace Tools section in the 2021 Shared Spaces Pricer).

HMASTS

11.5

0.8

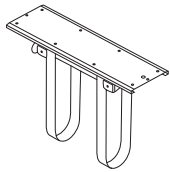
\$468**360° Swivel CPU Holder with Adjustable Straps**

- Supports CPUs 3¾" wide up to 64" perimeter and holds up to 75 lbs.
- 360° rotation.
- Ships complete and includes necessary mounting hardware and instruction sheet.

! Available in Black only, no specification needed.

HCPUI

7.0

0.2

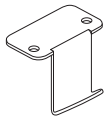
\$243**SIN 33721****Back Pack Hook (10 per carton)**

12"W x 14½"D x 1½"H

HCLA65

10.0

0.1

\$95

NOTES: Assembly: attaches to bottom of desk with (2) screws, included.

! Available in Platinum Metallic finish only, no specification needed.

**NOTES:**

- See the Workplace Tools section in the 2021 Shared Spaces Pricer for additional monitor arm models.

HOW TO SPECIFY**Select Model Number****Select Finish**

Specify for models HMASD and HMASTS only

SVR Silver**BLK** Black

HMASD.

SVR



Icon Legend on page 19

Shared Components & Accessories

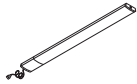

OPEN MARKET

DESCRIPTION

LED Task Lights

- 17" LED Light with Power Supply (Single)
- 31" LED Light with Power Supply (Single)
- 17" LED Light with Power Supply for Daisy-chain (Starter)
- 31" LED Light with Power Supply for Daisy-chain (Starter)
- 17" LED Light with 8" Jumper Cord for Daisy-chain (Follower)
- 31" LED Light with 8" Jumper Cord for Daisy-chain (Follower)

MODEL

- HLED17AS** ☹
- HLED31AS** ☹
- HLED17A**
- HLED31A**
- HLED17AUO** ☹
- HLED31AUO** ☹

SHIP WEIGHT

- 1.2
- 1.5
- 1.0
- 1.4
- 1.0
- 1.0

CUBE

- 0.05
- 0.09
- 0.05
- 0.09
- 0.03
- 0.05

LIST PRICE

- \$420**
- \$564**
- \$461**
- \$619**
- \$377**
- \$503**

Undercabinet Occupancy Sensor with 1" End to End Connector

HLEDOSA ☹

0.2

0.01

\$89

NOTES: To use the daisy chain application, must start with model HLED17A or HLED31A. No finish specification required. Attaches magnetically to underside of overhead storage, or attaches with provided screws or double-sided tape. Occupancy sensor attaches to a single or starter LED light and will automatically turn the light off after no motion is detected for 30 minutes. Just like all the LED light models, the occupancy sensor features a soft-touch on/off switch. LED task lights have a lifetime of 50,000 hours and have a dimmer feature that allows the user to adjust the amount of light output.



Refer to page 113

OPEN MARKET

Recessed Task Light

- 46 1/2"W x 3 1/16"D x 1 1/8"H for Models H115327, H11534, H11533 and H115324
- 34 3/8"W x 3 1/16"D x 1 1/8"H for Models H115323, H115322, H115382 and H115383
- 22 1/8"W x 3 1/16"D x 1 1/8"H for Models H115321, H115380 and H115381

- HH870960**
- HH870942**
- HH870930**

- 12.0
- 10.0
- 7.0

- 1.1
- 0.9
- 0.6

- \$270**
- \$250**
- \$231**

NOTES: For additional information see the Workplace Tools section in the 2021 Shared Spaces Pricer.



LED Task Lights

- Articulating Desk Lamp**
- Articulating Desk Lamp w/ Occupancy Sensor**

- HLED1**
- HLED1OC**

- 1.2
- 1.2

- 6.5
- 6.5

- \$402**
- \$490**

NOTES: For additional information see the Workplace Tools section in the 2021 Shared Spaces Pricer.

Task Desk Lamp

HLED2

0.7

3.0

\$348

NOTES: For additional information see the Workplace Tools section in the 2021 Shared Spaces Pricer.



Black only

Field Installable Grommet

- Grommet is field installable.
- Grommet shape is round.
- Includes grommet cap and sleeve.

- Grommet cap measures 3" diameter and includes a 3/4" diameter cord access hole.
- Grommet sleeve measures 2 1/2" O.D. x 3/4" thick.
- Includes instructions to locate grommet position for desks, credenzas, returns and bridges.

HFLDGRMT

0.1

0.01

\$32

NOTES: For additional information see the Workplace Tools section in the 2021 Shared Spaces Pricer.

- ☹ Designed to be used in top and end panels to route/hide cords, and in modesty panels to facilitate reaching wall electrical outlets.
- ☹ Black Finish
- ☹ Requires a 2 1/2" diameter hole saw and drill for installation (not included).



Field Installable Grommet

- Grommet is field installable.
- Grommet shape is round.
- Includes grommet cap and sleeve.

- Grommet outside dimensions measure 3 1/2" diameter and includes two cord access holes.
- Grommet sleeve measures 3" O.D. x 1" thick.
- Includes instructions to locate grommet position for desks, credenzas, returns and bridges.

HFLDGRMT3

0.1

0.3

\$32

NOTES: For additional information see the Workplace Tools section in the 2021 Shared Spaces Pricer.

- ☹ Designed to be used in top and end panels to route/hide cords, and in modesty panels to facilitate reaching wall electrical outlets.
- ☹ Black Finish
- ☹ Requires a 3" diameter hole saw and drill for installation (not included).

NOTES:

- See pages 153-169 for shared components.

HOW TO SPECIFY

Select Model Number	Select Color
<div style="display: flex; gap: 5px;"> <div style="border: 1px solid black; padding: 2px;">H</div> <div style="border: 1px solid black; padding: 2px;">H</div> <div style="border: 1px solid black; padding: 2px;">8</div> <div style="border: 1px solid black; padding: 2px;">7</div> <div style="border: 1px solid black; padding: 2px;">0</div> <div style="border: 1px solid black; padding: 2px;">9</div> <div style="border: 1px solid black; padding: 2px;">6</div> <div style="border: 1px solid black; padding: 2px;">0</div> </div>	Available in Black (P) only <div style="border: 1px solid black; padding: 2px; display: inline-block;">P</div>

VALIDO® Shared Components & Accessories

GSA SIN 33721T EXCEPT AS NOTED

ABI

Icon Legend on page 19

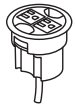
**DESCRIPTION****MODEL****SHIP WEIGHT****CUBE****LIST PRICE****Power Hub, 3" Grommet Mount, 6' Cord****HGRMTAC**

1.3

0.2

\$116

- Fits in 3" round grommet holes on the following product lines: 10500, 10700, Concinnity, Coordinate, and Voi desks; Abound Worksurfaces; Huddle and Motivate tables and SmartLink.
- Two grounded AC power outlets.
- Includes 6' cord with three-prong plug.
- Two cord pass-through holes in cap.
- Field installed; easy plug-and-play.
- UL Listed.

NOTES: For additional information see the Workplace Tools section in the 2021 Shared Spaces Pricer.

! Available in black only (no color designation so use .X - Specify: HGRMTAC.X).

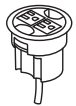
**3" Round Power Grommet - 2 Outlets, 10' Cord****HGRMTAC2**

1.5

0.2

\$148

- Includes 10' cord with three-prong plug.
- Fits in 3" round grommet holes on the following product lines: Coordinate, Huddle, Motivate, all laminate and veneer casegoods series, and Systems Worksurfaces.
- Two grounded AC power outlets.
- Field installed with Plug-and-play ease.

NOTES: Power Modules will also work with standing-height applications for 10500 Series™ and Voi® desks. Optional Memory Control allows preset worksurface heights for consistency. Ships separately. Dynamic load capacity when worksurface is moving is 300 lbs.

! Available in black finish only, no specification needed.

**Power/USB Hub, 3" Grommet Mount****HGRMTUSB2**

1.3 Ⓢ

0.02

\$226

- One grounded AC power outlet with 2 USB ports.
- Two cord pass-through holes in cap.
- Includes 6' cord with three-prong plug.
- Field installed; easy plug-and-play.
- UL Listed.

NOTES: For additional information see the Workplace Tools section in the 2021 Shared Spaces Pricer.

! Available in black only (no color designation so use .X - Specify: HGRMTUSB2.X).

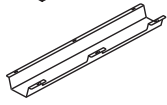
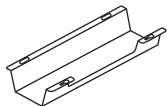

SIN 33721

Cable Management Troughs

17"W - Single

HCTROUGH17

2.7 Ⓢ

0.5

\$67

17"W - 10-Pack

HCTROUGH1710

14.0 Ⓢ

0.5

\$620

36"W - Single

HCTROUGH36

4.9 Ⓢ

0.9

\$113

36"W - 10-Pack

HCTROUGH3610

30.0 Ⓢ

0.9

\$1045

- Cable management troughs ship flat packed.
- The troughs attach to underneath the worksurface with screws.
- The 17"W has one wire access cut out on the user side. The 36" has two wire access cut outs. These cut outs give users access to inside the trough without having to detach it from the worksurface.
- Color: Graphite.
- Material: Metal.
- TAA Compliant.

NOTES: For additional information see the Workplace Tools section in the 2021 Shared Spaces Pricer.

HOW TO SPECIFYSelect
Model Number

H G R M T A C

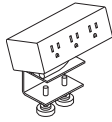

Model HPWRMOD3WC shown

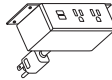

Model HPWRMOD2UWM shown

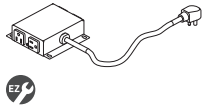
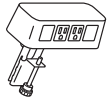

DESCRIPTION	MODEL	SHIP WEIGHT	CUBE	LIST PRICE
Power Modules				
3 Receptacles with Worksurface Clamp	HPWRMOD3WC	2.3	0.2	\$310
3 Receptacles with Under-Worksurface Mounting Bracket	HPWRMOD3UWM	2.3	0.2	\$310
2 Receptacles 2 USB with Worksurface Clamp	HPWRMOD2WC	2.3	0.2	\$496
2 Receptacles 2 USB with Under-Worksurface Mounting Bracket	HPWRMOD2UWM	2.3	0.2	\$496
<ul style="list-style-type: none"> • 6' power cord with standard three-prong plug. • Under-worksurface mounting bracket models work with any top that has a 5" x 5" square clearance. • Worksurface clamp models work on any top with a 4" overhang. • UL Listed. <p> Color finish coordinates with HON's Charcoal or White. Specify <i>STRM</i> for Storm or <i>SNW</i> for Snow when ordering. Example: <i>HPWRMOD3WC.STRM</i>.</p>				
Power & Data Center				
2 Receptacles 2 Data Accessory	HCOMDOME2	2.5	0.2	\$296
<ul style="list-style-type: none"> • Standard with two receptacles and openings for two data ports. • 6' power cord with standard three-prong plug. • Fits on any worksurface with a 4" overhang. • UL Listed. <p> Color finish coordinates with HON's Loft. Specify <i>LOFT</i> when ordering. Example: <i>HCOMDOME2.LOFT</i>.</p>				
Under Worksurface Power Module — 4 Outlets, 10' Cord				
	HPWRMOD2	1.5	0.2	\$401
<ul style="list-style-type: none"> • Includes 10' cord with three-prong plug. • Fits in cable management troughs. See page 168. • 4 outlets on side create easy access. <p>NOTES: Power Modules will also work with standing-height applications for 10500 Series™ and Voi® desks.</p> <p> Available in black finish only, no specification needed.</p>				
Vertebrae				
	HMPVWM28	3.0	0.3	\$223
<p>NOTES: 30"H x 3 1/8"W x 1 1/2"D. Ships unassembled.</p> <p> Clear finish. Specify "X" for finish option. SPECIFYING EXAMPLE: HMPVWM28.X</p>				

NOTES:

- For additional information see the Workplace Tools section in the 2021 Shared Spaces Pricer.

HOW TO SPECIFY

Select Model Number

H P W R M O D 3 W C

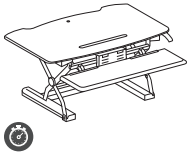
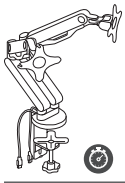
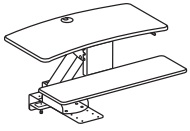
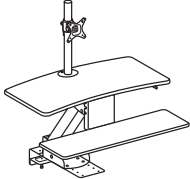
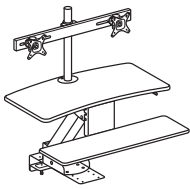
	DESCRIPTION	MODEL	SHIP WEIGHT	CUBE	LIST PRICE
	Coordinate™ Portable Desktop Riser 31"D x 5'-16½"H x 35"W NOTES: Available in Black (BLK) or White (WHT) finish. Desktop riser dimensions (without keyboard tray): 22"D x 5'-16½"H x 35"W. Keyboard tray dimensions: 9"D x 30"W. Max loading capacity is 33 lbs for the desktop riser surface and 4 lbs for the keyboard tray. Easily transition from seated to standing positions throughout the workday. Sits atop an existing desk to create sit-to-stand functionality by raising the computer. Includes keyboard tray and surface for computer monitors. HON 5-Year Limited Warranty. ! Not intended for use on mobile workstations.	HBXRISER	54.0	4.1	\$619
	Dual Monitor Arm with 2 USB Ports NOTES: Easy adjustment. Height adjusts to 17" tall. Monitor tilt and swivel capability. Enclosed cable management. Grommet or desktop mounting. In some applications the Monitor Arms may extend 12 or more inches into the worksurface. For additional information see the Workplace Tools section in the 2021 Shared Spaces Pricer. HON 5-Year Limited Warranty. ! No specification needed.	HBDMAUSB	41.9	2.6	\$383
	Coordinate™ Mounted Desktop Riser NOTES: Does not include a monitor arm and is suitable for laptops and/or monitors on their original stands. ! No specification needed.	HS1100	60.0 ☹	3.2	\$664
	Coordinate™ Mounted Desktop Riser with Single Monitor Arm NOTES: Includes a monitor arm for a single monitor. ! No specification needed.	HS1101	62.0 ☹	3.2	\$777
	Coordinate™ Mounted Desktop Riser with Dual Monitor Arm NOTES: Includes a monitor arm for dual monitors. ! No specification needed.	HS1102	63.0 ☹	3.2	\$883

NOTES FOR HS1100, HS1101, HS1102:

- These products are designed to allow the user to transition from seating position to standing position throughout the workday.
- Gas-assist lever-operated mechanism with positive stop.
- Clamp mount compatible with worksurfaces depths of 20"-30". 20" is for systems only.
- Clamp requires 3.5" of clearance along back edge of worksurface.
- Black seamless worksurfaces.
- Silver powder coated metal components.
- Lowers below worksurface level on 24" and 30"D worksurfaces.
- All models contain a large primary worksurface and a smaller keyboard / mouse surface.
- Beveled edges for sleek appearance and comfort while typing.
- Monitor arms include height, width, and swivel adjustment.

- Not for use under overhead storage, with flush mounted modesty panels, or worksurfaces thinner than 1".

- ! Not recommended for use on mobile (castered) worksurfaces.

MOUNTING AND COMPATIBILITY FOR HS1100, HS1101, HS1102:

- This product is intended to be installed on commercial-grade worksurfaces in good condition.
- Compatible with freestanding worksurfaces 24"-30"D or panel-supported worksurfaces 24"-30"D.
- Not for use on mobile worksurfaces.

Clamp Mount

Use when 3.5" minimum overhang is available

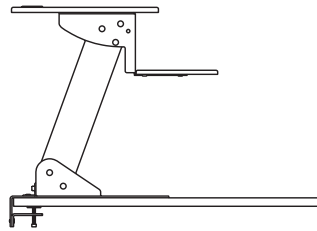
**Screw Mount**

Use when no overhang is available. Worksurface must be minimum 1" thick.

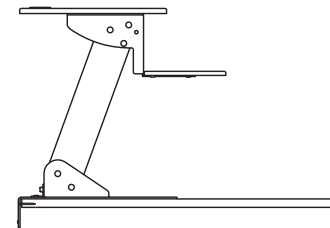

**HOW TO SPECIFY****Select Model Number**

HBXRISER.

Select FinishBLK Black
WHT White

BLK

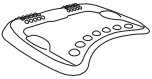
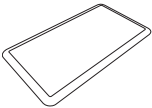
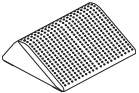

	DESCRIPTION	MODEL	SHIP WEIGHT	CUBE	LIST PRICE
	Rectangle Wobble Board — Anti-Fatigue Mat 18"D x 3"H x 22¼"W ⓘ Available in Black (T) finish ONLY. Recommended weight capacity not to exceed 250 pounds. HON 5-Year Limited Warranty. SPECIFYING EXAMPLE: HVL981.T	HVL981 ⓘ	10.0 Ⓔ	0.9	\$121
	Round Wobble Board — Anti-Fatigue Mat 18½"D x 2⅝"H x 18½"W ⓘ Available in Black (T) finish ONLY. Recommended weight capacity not to exceed 250 pounds. HON 5-Year Limited Warranty. SPECIFYING EXAMPLE: HVL982.T	HVL982 ⓘ	5.8 Ⓔ	0.6	\$103
	Ergonomic Anti-Fatigue Mat 25"D x 2¾"H x 29⅞"W ⓘ Available in Black ONLY. No specification needed. SPECIFYING EXAMPLE: HBEAFM1	HBEAFM1	7.0	1.4	\$219
	Rectangle Anti-Fatigue Mat 20"D x ¾"H x 36"W ⓘ Available in Black ONLY. No specification needed. SPECIFYING EXAMPLE: HBAFM2036	HBAFM2036 ⓘ	5.4	0.4	\$100
	Footrest — Anti-Slip Cover 13¾"D x 5½"H x 16"W ⓘ Available in Black (T) finish ONLY. Recommended weight capacity not to exceed 250 pounds. HON 5-Year Limited Warranty. SPECIFYING EXAMPLE: HVL991.T	HVL991	7.0 Ⓔ	0.9	\$82

NOTES:

ⓘ Discontinued 1/1/21.

HOW TO SPECIFY

Select Model Number	Select Finish
H V L 9 8 1 .	T Black
	T

VOI®



Voi® shown with Ignition® Seating.

VOI®

Voi gets you. Your needs. Your style. Your environment. Voi packs a lot of functionality into a little space, so you can maximize yours. Plus, versatile Voi integrates easily with a variety of spaces, systems — even open plans. Solidly built and strikingly designed, Voi combines classic warmth and contemporary cool with an extensive variety of laminates, colors, components and configurations. So you can create a sophisticated, professional look that is uniquely yours.

**FEATURES**

- Big. Small. Functional. Adaptable. Voi has multiple options to meet your storage needs and available space.
- To create an office look that's uniquely yours, mix things up — with tasteful modesty panels, stylish storage cubes and mixed surface materials.
- Refined scale. Layered workspaces. Together they help streamline your office to create small-footprint spaces that work BIG.
- With so many configurations and combinations, Voi® makes it easy to create a stylish, unified look across your entire office.

VOI® ORDERING INFORMATION

WORKSURFACES

L1 LAMINATES CODES

Woodgrain

- ◆ Bourbon Cherry H
- ◆ Cognac COGN
- ◆ Florence Walnut LFW1
- ◆ Harvest C
- ◆ Kingswood Walnut LK11
- ◆ Mahogany N
- ◆ Mocha MOCH
- ◆ Natural Maple D
- ◆ Pinnacle PINC
- ◆ Shaker Cherry F
- ◆ Sterling Ash LSA1

Solid

- ◆ Black P
- ◆ Charcoal S
- ◆ Designer White LDW1
- ◆ Loft LOFT

Patterned

- ◆ Sheer Mesh* A5
- ◆ Silver Mesh** B9

L2 LAMINATES*** CODES

Woodgrain

- ◆ Lowell Ash LLA1
- ◆ Natural Recon LNR1
- ◆ Phantom Ecru LPE1
- ◆ Portico Teak LPT1
- ◆ Skyline Walnut LSW1

WORKSURFACE EDGE BAND

Woodgrain

- ◆ Bourbon Cherry H
- ◆ Cognac COGN
- ◆ Designer White DW
- ◆ Florence Walnut FW
- ◆ Harvest C
- ◆ Kingswood Walnut KI
- ◆ Loft LOFT
- ◆ Lowell Ash DL
- ◆ Mahogany N
- ◆ Mocha MOCH
- ◆ Muslin T
- ◆ Natural Maple D
- ◆ Natural Recon NR
- ◆ Phantom Ecru PE
- ◆ Pinnacle PINC
- ◆ Portico Teak DP
- ◆ Shadow* SHDW
- ◆ Shaker Cherry F
- ◆ Skyline Walnut SW
- ◆ Sterling Ash SA

CHASSIS/CABINET DRAWER/DOOR FRONTS, LAMINATE END PANELS, LAYERING SHELVES AND MODESTY PANELS

L1 LAMINATES CODES

Woodgrain

- ◆ Bourbon Cherry H
- ◆ Cognac COGN
- ◆ Florence Walnut LFW1
- ◆ Harvest C
- ◆ Kingswood Walnut LK11
- ◆ Mahogany N
- ◆ Mocha MOCH
- ◆ Natural Maple D
- ◆ Pinnacle PINC
- ◆ Shaker Cherry F
- ◆ Sterling Ash LSA1

Solid

- ◆ Black P
- ◆ Charcoal S
- ◆ Designer White LDW1
- ◆ Loft LOFT

L2 LAMINATES*** CODES

Woodgrain

- ◆ Lowell Ash LLA1
- ◆ Natural Recon LNR1
- ◆ Phantom Ecru LPE1
- ◆ Portico Teak LPT1
- ◆ Skyline Walnut LSW1

WORKSURFACE GROMMETS

PLASTIC CODES

- ◆ Black P
- ◆ Brownstone EY
- ◆ Charcoal S
- ◆ Designer White DW
- ◆ Fossil EH
- ◆ Greige R
- ◆ Loft LOFT
- ◆ Muslin T3
- ◆ Platinum T1
- ◆ Shadow* SD
- ◆ Titanium T1

PULLS & FEET

PAINT CODES

- P1**
- ◆ Black P
- ◆ Designer White PJW
- P2**
- ◆ Champagne Metallic T4
- ◆ Platinum Metallic T1
- ◆ Silver PR6
- ◆ Solar Black P8X

O-LEGS, STEEL LEGS, POST LEGS, SHELF BRACKETS, SHARED LEGS, STORAGE CUBES

PAINTS CODES

- P1**
- ◆ Black P
- ◆ Brownstone P7D
- ◆ Charcoal S
- ◆ Designer White PJW
- ◆ Fossil P28
- ◆ Greige T5
- ◆ Loft LOFT
- ◆ Muslin T3
- ◆ Shadow* SHDW
- ◆ Titanium P8T
- P2**
- ◆ Champagne Metallic T4
- ◆ Platinum Metallic T1
- ◆ Silver PR6
- ◆ Solar Black P8X
- P3**
- ◆ Atom P8S
- ◆ Blossom**** P8K
- ◆ Bullseye PJF
- ◆ Cabernet**** P7T
- ◆ Conifer**** P8H
- ◆ Ember P8P
- ◆ Ion P8N
- ◆ Iris P8J
- ◆ Krypton P8F
- ◆ Regatta P8M
- ◆ Succulent**** P8A

ANGLED WOOD LEGS

- ◆ Clear Ash LA400
- ◆ Medium Ash LA484

WORKSURFACE LAMINATES	CODES	EDGE BAND OPTIONS				
		Matching Edge	Designer White (DW)	Loft (LOFT)	Muslin (T)	Black (P)
Black	P					*
Bourbon Cherry	H	*	*		*	
Charcoal	S	*				
Cognac	COGN	*	*		*	
Designer White	LDW1		*			
Harvest	C	*	*		*	
Loft	LOFT			*		
Lowell Ash	LLA1	*	*	*	*	
Mahogany	N	*		*		
Mocha	MOCH	*	*		*	
Natural Maple	D	*	*	*	*	
Natural Recon	LNR1	*	*	*	*	
Phantom Ecru	LPE1	*	*	*	*	
Pinnacle	PINC	*	*	*	*	
Portico Teak	LPT1	*	*	*	*	
Shaker Cherry	F	*	*	*	*	
Sheer Mesh	A5				*	
Silver Mesh	B9			*		
Skyline Walnut	LSW1	*	*	*	*	
Sterling Ash	LSA1	*	*	*	*	*
Kingswood Walnut	LK11	*	*	*	*	*
Florence Walnut	LFW1	*	*	*	*	*

* Sheer Mesh laminate will have Muslin Edgeband. Sheer Mesh NOT available on Chassis/Cabinet, Drawer/Door Fronts, Laminate End Panels, Layering Shelves and Modesty Panels.

** Silver Mesh laminate will have Loft Edgeband. Silver Mesh NOT available on Chassis/Cabinet, Drawer/Door Fronts, Laminate End Panels, Layering Shelves and Modesty Panels.

*** Storage chassis that are specified in L2 laminates and are longer than 60" W will ship with back panels that are horizontal grain.

**** TREND COLORS: These colors are intended to be an inspirational option for the trending market. Product application is limited and color availability is approximately two years to coincide with evolving workplace trends.

◆◆◆ For lead time information see page 19.

* De-emphasized

VOI® Laminate Typicals



Icon Legend on page 19

QTY	DESCRIPTION	MODEL	LIST PRICE	PRICE EXTENSION
1	External Channel 54"W	HLSLZ5SC66	\$101	\$101
1	Rectangle Worksurface 24"D x 66"W	HLSLR2466	\$389	\$389
1	Low Credenza (Right hand drawers) 60"W x 20"D x 21½"H	HLSL2060LR2	\$1,286	\$1,286
1	Layering Shelf 60"W x 14½"D x 5½"H	HLSL1460LS	\$372	\$372
2	O-Leg Support for Worksurface (1 pack) 24"D x 28½"H	HLSL24280	\$324	\$648
1	Overhead Cabinet with Wall Bracket with One Sliding Door 60"W x 14¼"D x 14"H	HLSL1460S	\$1,335	\$1,335
TOTAL:			\$4,131	

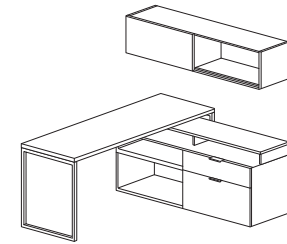
**SMALL FOOTPRINT****66" x 60"**

QTY	DESCRIPTION	MODEL	LIST PRICE	PRICE EXTENSION
1	External Channel 54"W	HLSLZ5SC66	\$101	\$101
1	Rectangle Worksurface 24"D x 66"W	HLSLR2466	\$389	\$389
1	Low Credenza (2 file/2 box) 60"W x 20"D x 21½"H	HLSL2060LD4	\$1,500	\$1,500
2	O-Leg Support for Worksurface (1 pack) 24"D x 28½"H	HLSL24280	\$324	\$648
1	Overhead Cabinet with 4 Doors 60"W x 14¼"D x 14"H	HLSL1460D	\$1,185	\$1,185
1	O-Leg Support for Overhead Cabinet 14½"D x 20½"H for 65"H Overhead Cabinet	HLSL650S	\$479	\$479
TOTAL:			\$4,302	

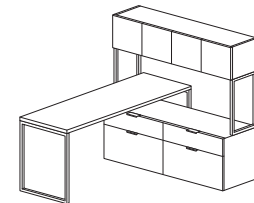
**SMALL FOOTPRINT****66" x 60"**

QTY	DESCRIPTION	MODEL	LIST PRICE	PRICE EXTENSION
1	Low Credenza, Right Hand Drawers, Footed 60"W x 20"D x 24½"H	HLSL2060LR2F	\$1,356	\$1,356
1	Cube Bundle A	HLSL15-SOO	\$294	\$294
2	Drawer Cube 15"W x 13"D x 4"H	HLSL154LSD	\$221	\$442
1	Voi® Shelf 30"W x 13"D	HLSLR1330	\$191	\$191
1	Angled Steel Leg 29"H	HLSL28AM2	\$323	\$323
1	4"H Steel Stanchion	HLSL4AM2	\$151	\$151
1	Rectangle Worksurface 72"W x 30"D	HLSLR3072	\$480	\$480
1	Mixed Material Floating Modesty Panel 42"W x 14"H	HLSL4214MM	\$826	\$826
TOTAL:			\$4,063	

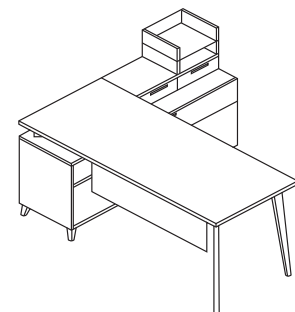
**SMALL FOOTPRINT****60" W x 72" D**



Icon Legend on page 19

VOI®

Laminate Typicals

DESKS

QTY	DESCRIPTION	MODEL	LIST PRICE	PRICE EXTENSION
1	Mixed Material Floating Modesty Panel 42"W x 14"H	HLSL4214MM	\$826	\$826
1	Rectangular Worksurface 48"W x 24"D	HLSLR2448	\$306	\$306
2	Drawer Cube 15"W x 13"D x 4"H	HLSL154LSD	\$221	\$442
1	Cube Bundle A	HLSL15-SOO	\$294	\$294
2	Angled Steel Leg 29"H	HLSL28AM2	\$323	\$646
1	Rectangle Worksurface 60"W x 30"D	HLSLR3060	\$410	\$410
1	Voi® Shelf 30"W x 13"D	HLSLR1330	\$191	\$191
1	Support Pedestal 24"W x 28"D	HLSL2428B	\$778	\$778
TOTAL:			\$3,893	

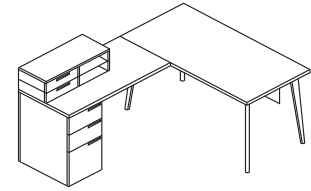

SMALL FOOTPRINT
78"W x 60"D

QTY	DESCRIPTION	MODEL	LIST PRICE	PRICE EXTENSION
1	Box/File Pedestal, Footed 16"W x 20"D x 28½"H	HLSL2016FP2	\$869	\$869
2	Drawer Cube 15"W x 13"D x 4"H	HLSL154LSD	\$221	\$442
1	Cube Bundle A	HLSL15-SOO	\$294	\$294
1	Short Open Cube 15"W x 13"D x 4"H	HLSL154LSO	\$147	\$147
1	Voi® Shelf 30"W x 13"D	HLSLR1330	\$191	\$191
2	Voi® Shelf 45"W x 13"D	HLSLR1345	\$232	\$464
1	4"H Steel Stanchion	HLSL4AM2	\$151	\$151
1	Rectangle Worksurface 72"W x 30"D	HLSLR3072	\$480	\$480
1	Rectangular Worksurface 48"W x 24"D	HLSLR2448	\$306	\$306
1	Shelf Brackets	HLSLSB	\$96	\$96
1	Mixed Material Floating Modesty Panel 54"W x 14"H	HLSL5414MM	\$992	\$992
2	Angled Wood Leg 29"H	HLSL28AW2	\$420	\$840
TOTAL:			\$5,272	

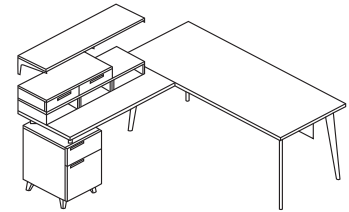

SMALL FOOTPRINT WITH SHELF
78"W x 72"D

QTY	DESCRIPTION	MODEL	LIST PRICE	PRICE EXTENSION
1	Low Credenza, 2 File/Open, Footed 60"W x 20"D x 24½"H	HLSL2060LD2F	\$1,475	\$1,475
1	Cabinet Cube, Left Handed 15"W x 13"D x 12"H	HLSL1512LSCL	\$221	\$221
1	Short Open Cube 15"W x 13"D x 4"H	HLSL154LSO	\$147	\$147
2	Drawer Cube 15"W x 13"D x 4"H	HLSL154LSD	\$221	\$442
1	Voi® Shelf 45"W x 13"D	HLSLR1345	\$232	\$232
2	Angled Steel Leg 29"H	HLSL28AM2	\$323	\$646
1	Rectangle Worksurface with Stiffener 60"W x 30"D	HLSLR3060W	\$484	\$484
1	Mixed Material Floating Modesty Panel 42"W x 14"H	HLSL4214MM	\$826	\$826
TOTAL:			\$4,473	

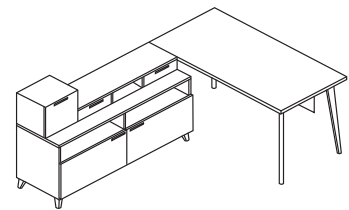

SMALL FOOTPRINT
90"W x 60"D

VOI® Laminate Typicals



Icon Legend on page 19

QTY	DESCRIPTION	MODEL	LIST PRICE	PRICE EXTENSION
1	Cube Bundle A	HLSL15-SOO	\$294	\$294
2	Angled Steel Leg 29"H	HLSL28AM2	\$323	\$646
1	Rectangle Worksurface 72"W x 30"D	HLSLR3072	\$480	\$480
1	Mixed Material Floating Modesty Panel 54"W x 14"H	HLSL5414MM	\$992	\$992
1	Low Credenza, 2 File/Open, Footed 60"W x 20"D x 24½"H	HLSL2060LD2F	\$1,475	\$1,475
4	Drawer Cube 15"W x 13"D x 4"H	HLSL154LSD	\$221	\$884
2	Voi® Shelf 30"W x 13"D	HLSLR1330	\$191	\$382
TOTAL:			\$5,153	

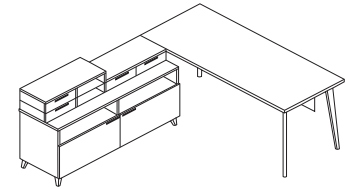

**SMALL FOOTPRINT WITH
SIX CUBES**
90" W x 72" D

QTY	DESCRIPTION	MODEL	LIST PRICE	PRICE EXTENSION
1	Low Credenza, 2 File/Open, Footed 60"W x 20"D x 24½"H	HLSL2060LD2F	\$1,475	\$1,475
1	Low Credenza, Open, Footed 30"W x 20"D x 24½"H	HLSL2030LD0F	\$945	\$945
1	Cube Bundle C	HLSL15-SODLOC	\$765	\$765
2	Voi® Shelf 45"W x 13"D	HLSLR1345	\$232	\$464
1	Angled Steel Leg 29"H	HLSL28AM2	\$323	\$323
1	4"H Steel Stanchion	HLSL4AM2	\$151	\$151
1	Rectangle Worksurface 72"W x 30"D	HLSLR3072	\$480	\$480
1	Mixed Material Floating Modesty Panel 42"W x 14"H	HLSL4214MM	\$826	\$826
TOTAL:			\$5,429	

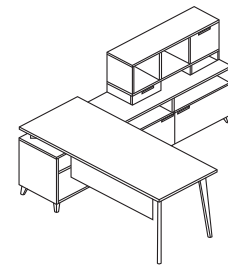

**MEDIUM FOOTPRINT WITH
CUBE BUNDLE C**
90" W x 72" D

QTY	DESCRIPTION	MODEL	LIST PRICE	PRICE EXTENSION
1	External Channel 48"W	HLSLZ5SC60	\$98	\$98
1	Rectangle Worksurface 30"D x 72"W	HLSLR3072	\$480	\$480
1	Rectangle Worksurface 20"D x 72"W	HLSLR2072	\$400	\$400
1	Low Credenza (2 file drawers) 60"W x 20"D x 21½"H	HLSL2060LD2	\$1,405	\$1,405
1	Overhead Cabinet - Metal Frame, Glass Doors 72"W x 14¼"D x 14"H	HLSL1472M	\$2,198	\$2,198
1	O-Leg Stack-on Storage Support (2 pack) 65"H	HLSL65OS	\$479	\$479
1	O-Leg Support for Worksurface (1 pack) 20"D x 28½"H	HLSL2028O	\$298	\$298
2	O-Leg Support for Worksurface (1 pack) 30"D x 28½"H	HLSL3028O	\$359	\$718
1	Box/Box/File Pedestal Support 20"D x 28½"H	HLSL2028B	\$704	\$704
1	Mixed Material Floating Modesty Panel 60"W x 14"H	HLSL6014MM	\$1,134	\$1,134
1	Storage Cube 12" x 12"	HLSL1212	\$294	\$294
TOTAL:			\$8,208	

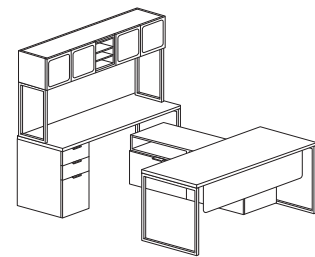

PRIVATE OFFICE
92" x 72"



Icon Legend on page 19

VOI®

Laminate Typicals

DESKS

QTY	DESCRIPTION	MODEL	LIST PRICE	PRICE EXTENSION
2	Low Credenza, 2 File/Open, Footed 60"W x 20"D x 24½"H	HLSL2060LD2F	\$1,475	\$2,950
2	Low Credenza, Open, Footed 30"W x 20"D x 24½"H	HLSL2030LD0F	\$945	\$1,890
1	Cube Bundle E	HLSL15-SO0DDLOC	\$1,133	\$1,133
2	Drawer Cube 15"W x 13"D x 4"H	HLSL154LSD	\$221	\$442
2	Short Open Cube 15"W x 13"D x 4"H	HLSL154LSO	\$147	\$294
1	Tall Open Cube 15"W x 13"D x 12"H	HLSL1512LSO	\$176	\$176
1	Cabinet Cube, Left Handed 15"W x 13"D x 12"H	HLSL1512LSCL	\$221	\$221
2	Mixed Material Floating Modesty Panel 42"W x 14"H	HLSL4214MM	\$826	\$1,652
2	Voi® Shelf 30"W x 13"D	HLSLR1330	\$191	\$382
4	Voi® Shelf 45"W x 13"D	HLSLR1345	\$232	\$928
2	Angled Steel Leg 29"H	HLSL28AM2	\$323	\$646
2	4"H Steel Stanchion	HLSL4AM2	\$151	\$302
2	Rectangle Worksurface 72"W x 30"D	HLSLR3072	\$480	\$960
TOTAL:				\$11,976

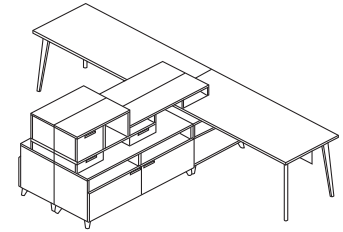

**LARGE FOOTPRINT
ADJACENT TEAMING**
90"W x 144"D

QTY	DESCRIPTION	MODEL	LIST PRICE	PRICE EXTENSION
1	Box/Box/File Pedestal Support 30"D x 28"H	HLSL3028B	\$876	\$876
1	Rectangle Worksurface 36"D x 72"W	HLSLR3672	\$623	\$623
1	End Panel Support 24"D x 28½"H	HLSL2428E	\$207	\$207
1	End Panel Support 30"D x 28½"H	HLSL3028E	\$221	\$221
1	Rectangle Worksurface 20"D x 42"W	HLSLR2042	\$268	\$268
1	Rectangle Worksurface 24"D x 72"W	HLSLR2472	\$402	\$402
1	Mixed Material Floating Modesty Panel 42"W x 14"H	HLSL4214MM	\$826	\$826
1	Lateral File 36"W x 24"D x 28½"H	HLSL2430L	\$1,207	\$1,207
1	Overhead Cabinet - Metal Frame, Glass Doors 72"W x 14¼"D x 14"H	HLSL1472M	\$2,348	\$2,348
1	Storage Cube 12" x 12"	HLSL1212	\$294	\$294
TOTAL:				\$7,272

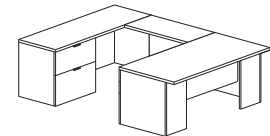
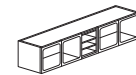

PRIVATE OFFICE
102" x 72"

VOI® Laminate Typicals



Icon Legend on page 19

QTY	DESCRIPTION	MODEL	LIST PRICE	PRICE EXTENSION
1	Low Credenza, 2 File/Open, Footed 60"W x 20"D x 24½"H	HLSL2060LD2F	\$1,475	\$1,475
1	Low Credenza, 1 File/Open, Footed 30"W x 20"D x 24½"H	HLSL2030LD1F	\$1,044	\$1,044
1	Left Hand Door, Footed 18"W x 20"D x 4"H	HLSLW084LF	\$1,308	\$1,308
2	Drawer Cube 15"W x 13"D x 4"H	HLSL154LSD	\$221	\$442
2	Cube Bundle A	HLSL15-SOO	\$294	\$588
1	Cube Bundle D	HLSL15-SDDLCC	\$884	\$884
2	Voi® Shelf 45"W x 13"D	HLSLR1345	\$232	\$464
2	Voi® Shelf 30"W x 13"D	HLSLR1330	\$191	\$382
2	Angled Wood Leg 29"H	HLSL28AW2	\$420	\$840
1	Rectangle Top, Knife Edge 72"W x 30"D	HLSLR3072J	\$656	\$656
1	Mixed Material Floating Modesty Panel 54"W x 14"H	HLSL5414MM	\$992	\$992
TOTAL:			\$9,075	

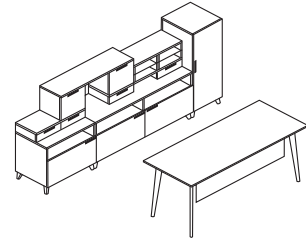

**PRIVATE OFFICE WITH
TABLE DESK**
108" W x 50" D

QTY	DESCRIPTION	MODEL	LIST PRICE	PRICE EXTENSION
1	Tower (Right hand drawers/Left hand door) 24"W x 20"D x 65"H, Left	HLSLW046L	\$2,231	\$2,231
1	Layering Shelf 60"W x 14½"D x 5½"H	HLSL1460LS	\$372	\$372
1	Rectangle Worksurface 30"D x 72"W	HLSLR3072	\$480	\$480
1	Mixed Material Floating Modesty Panel 42"W x 14"H	HLSL4214MM	\$826	\$826
2	O-Leg Support for Worksurface (1 pack) 30"D x 28½"H	HLSL30280	\$359	\$718
1	Low Credenza (2 file/2 box) 60"W x 20"D x 21½"H	HLSL2060LD4	\$1,500	\$1,500
1	Low Credenza (Open/Right hand drawers) 60"W x 20"D x 21½"H	HLSL2060LR2	\$1,286	\$1,286
1	Credenza Cushion 20"W x 30"D x 1"H	HLSL2030CH2	\$380	\$380
TOTAL:			\$7,793	

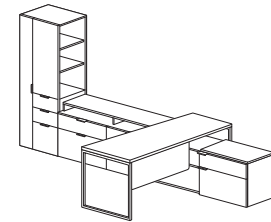

PRIVATE OFFICE
144" x 72"

QTY	DESCRIPTION	MODEL	LIST PRICE	PRICE EXTENSION
1	Personal Storage Tower (Left handed) 24"W x 24"D x 65"H	HLSLW446LP	\$2,660	\$2,660
2	Lateral File 30"W x 24"D x 28½"H	HLSL2430L	\$1,207	\$2,414
1	Rectangle Worksurface 24"D x 60"W	HLSLR2460	\$358	\$358
1	Rectangle Worksurface 30"D x 72"W	HLSLR3072	\$480	\$480
1	Rectangle Worksurface 24"D x 54"W	HLSLR2454	\$330	\$330
2	O-Leg Support for Worksurface (1 pack) 30"D x 28½"H	HLSL30280	\$359	\$718
2	Overhead Cabinet with Wall Bracket with One Sliding Door 72"W x 14¼"D x 13"H	HLSL1472S	\$1,578	\$3,156
2	Storage Cube 12" x 12"	HLSL1212	\$294	\$588
1	External Channel 60"W	HLSLZ5SC72	\$110	\$110
TOTAL:			\$10,814	

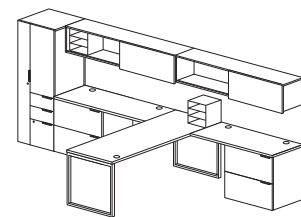

OPEN PLAN
168" x 72"



Icon Legend on page 19

VOI®

Laminate Typicals

DESKS

QTY	DESCRIPTION	MODEL	LIST PRICE	PRICE EXTENSION
1	Low Credenza, Left Hand Drawers, Footed 60"W x 20"D x 24½"H	HLSL2060LL2F	\$1,356	\$1,356
1	Low Credenza, 1 File/1 Box, Footed 30"W x 20"D x 24½"H	HLSL2030LD2F	\$1,154	\$1,154
4	Drawer Cube 15"W x 13"D x 4"H	HLSL154LSD	\$221	\$884
3	Cube Bundle A	HLSL15-SOO	\$294	\$882
1	Cabinet Cube, Right Handed 15"W x 13"D x 12"H	HLSL1512LSCR	\$221	\$221
1	Cabinet Cube, Left Handed 15"W x 13"D x 12"H	HLSL1512LSCL	\$221	\$221
1	Low Credenza, Right Hand Drawers, Footed 60"W x 20"D x 24½"H	HLSL2060LR2F	\$1,356	\$1,356
1	Voi® Shelf 30"W x 13"D	HLSLR1330	\$191	\$191
4	Voi® Shelf 45"W x 13"D	HLSLR1345	\$232	\$928
2	Angled Steel Leg 29"H	HLSL28AM2	\$323	\$646
2	4"H Steel Stanchion	HLSL4AM2	\$151	\$302
2	Rectangle Worksurface 72"W x 30"D	HLSLR3072	\$480	\$960
2	Mixed Material Floating Modesty Panel 42"W x 14"H	HLSL4214MM	\$826	\$1,652
TOTAL:			\$10,753	

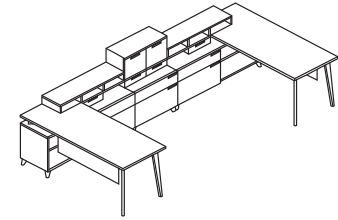

**LARGE TEAMING STATION
WITH ENHANCED STORAGE**
150" W x 72" D

QTY	DESCRIPTION	MODEL	LIST PRICE	PRICE EXTENSION
4	External Channel 48"W	HLSLZ5SC60	\$98	\$392
2	Accelerate® Raceway Panels 42½"H x 60"W	HETP4260FP	\$434	\$868
2	Accelerate® Raceway Panels 50"H x 60"W	HETP5060FP	\$483	\$966
2	Electrical Power Harness, 3-1 & 2-2 60"W	HH871260	\$216	\$432
4	Duplex Receptacle Circuit 3, 3-1	HH871503	\$42	\$168
1	Power In-Feed	HH879072	\$229	\$229
2	Low Credenza (Right hand drawers) 60"W x 20"D x 21½"H	HLSL2060LR2	\$1,286	\$2,572
2	Low Credenza (Left hand drawers) 60"W x 20"D x 21½"H	HLSL2060LL2	\$1,286	\$2,572
4	Credenza Cushion 20"W x 30"D x 1"H	HLSL2030CH2	\$380	\$1,520
4	O-Leg Support for Worksurface (1 pack) 30"D x 28½"H	HLSL2428O	\$324	\$1,296
2	Left O-Leg to Panel Bracket	HLSLPBL	\$100	\$200
2	Right O-Leg to Panel Bracket	HLSLPBR	\$100	\$200
4	Accelerate® Top Cap 60"W	HETC60	\$84	\$336
2	Accelerate® Variable Height Finishing Kit	HECVH07P	\$53	\$106
2	Accelerate® Finished End Cover 50"H	HEFEC50P	\$58	\$116
2	Accelerate® Finished End Cover 42½"H	HEFEC42P	\$54	\$108
1	Accelerate® "X" Connector 50"H	HEC50PX	\$144	\$144
4	O-Leg Support for Worksurface 24"D x 7"H	HLSL247O	\$218	\$872
4	Rectangle Worksurface 24"D x 60"W	HLSLR2460	\$358	\$1,432
TOTAL:			\$14,529	

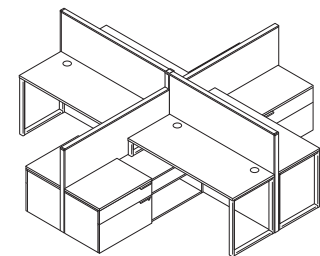

OPEN PLAN
120" x 120"

VOI® Laminate Typicals



Icon Legend on page 19

QTY	DESCRIPTION	MODEL	LIST PRICE	PRICE EXTENSION
4	External Channel 60"W	HLSLZ55C72	\$110	\$440
4	Rectangle Worksurface 24"D x 72"W	HLSLR2472	\$402	\$1,608
2	O-Leg Shared Support for Low Credenzas	HLSL247SL	\$272	\$544
2	Double Depth O-Leg Support for Worksurface 48"D x 28½"H	HLSL4828O	\$610	\$1,220
2	Low Credenza (Right hand drawers) 60"W x 20"D x 21½"H	HLSL2060LR2	\$1,286	\$2,572
2	Low Credenza (Left hand drawers) 60"W x 20"D x 21½"H	HLSL2060LL2	\$1,286	\$2,572
2	Above/Below Privacy Screen 60"W x 28½"H	HLSL2860	\$1,426	\$2,852
TOTAL:			\$11,808	

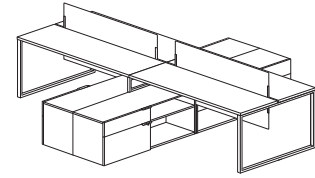

OPEN PLAN
144" x 120"

QTY	DESCRIPTION	MODEL	LIST PRICE	PRICE EXTENSION
1	Low Credenza, Right Hand Drawers, Footed 60"W x 20"D x 24½"H	HLSL2060LR2F	\$1,356	\$1,356
1	Low Credenza, Left Hand Drawers, Footed 60"W x 20"D x 24½"H	HLSL2060LL2F	\$1,356	\$1,356
1	Cube Bundle A	HLSL15-SOO	\$294	\$294
2	Drawer Cube 15"W x 13"D x 4"H	HLSL154LSD	\$221	\$442
1	Cabinet Cube, Right Handed 15"W x 13"D x 12"H	HLSL1512LSCR	\$221	\$221
1	Cabinet Cube, Left Handed 15"W x 13"D x 12"H	HLSL1512LSCL	\$221	\$221
3	Voi® Shelf 30"W x 13"D	HLSLR1330	\$191	\$573
4	Angled Steel Leg 29"H	HLSL28AM2	\$323	\$1,292
2	Rectangle Top, Knife Edge 60"W x 30"D	HLSLR3060J	\$561	\$1,122
TOTAL:			\$6,877	

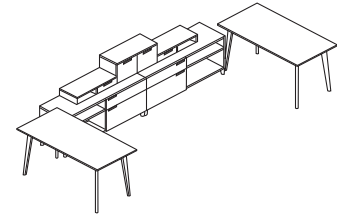

**LARGE FOOTPRINT
TEAMING**
180" W x 80" D



Icon Legend on page 19

VOI® Bundles Typicals

VT6030MB

Worksurface is Silver Mesh, Mobile Pedestal is Harvest, O-Leg Supports and grommets are Platinum Metallic.

QTY	DESCRIPTION	MODEL	LIST PRICE	PRICE EXTENSION
1	Rectangle Worksurface with External Support Channel	HLSLR3060W*	\$484	\$484
2	O-Leg Support for Worksurface	HLSL30280	\$363	\$726
1	Mobile Pedestal	HLSL2016MP2	\$813	\$813
TOTAL:			\$2,023	

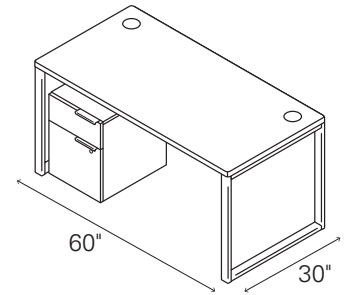
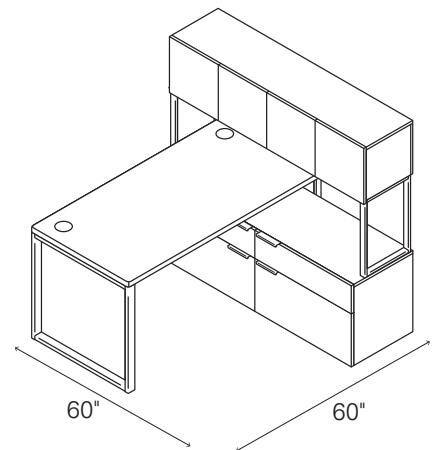

**TABLE DESK WITH MOBILE PEDESTAL
(NON-HANDED)**

VS6060L1B

Worksurface is Silver Mesh, Low Credenza and Overhead Cabinet are Harvest, O-Leg Supports and grommets are Platinum Metallic.

QTY	DESCRIPTION	MODEL	LIST PRICE	PRICE EXTENSION
1	Rectangle Worksurface with External Support Channel	HLSLR3060W*	\$484	\$484
2	O-Leg Support for Worksurface	HLSL30280	\$363	\$726
1	Low Credenza, 2 File/2 Box	HLSL2060LD4	\$1,500	\$1,500
1	Overhead Cabinet with 4 Doors	HLSL1460D	\$1,185	\$1,185
1	O-Leg Support for Overhead Cabinet (Pair)	HLSL650S	\$483	\$483
TOTAL:			\$4,378	



**SMALL FOOTPRINT L-STATION
(NON-HANDED)**

VS6060L6B

Worksurface is Silver Mesh, Low Credenza and Layering Shelf are Harvest, O-Leg Supports and grommets are Platinum Metallic.

QTY	DESCRIPTION	MODEL	LIST PRICE	PRICE EXTENSION
1	Rectangle Worksurface with External Support Channel	HLSLR3060W*	\$484	\$484
2	O-Leg Support for Worksurface	HLSL30280	\$363	\$726
1	Low Credenza, Right-hand Drawers	HLSL2060LR2	\$1,286	\$1,286
1	Layering Shelf	HLSL1460LS	\$372	\$372
TOTAL:			\$2,868	

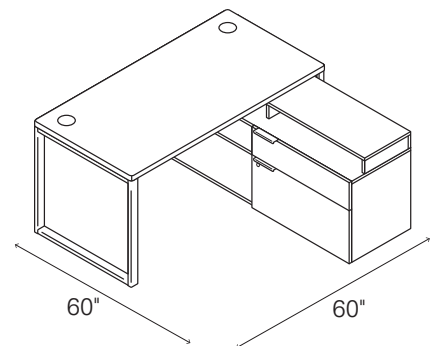

**SMALL FOOTPRINT L-STATION
(RIGHT HANDED, LOW CREDENZA)**

*Worksurface model **HLSLR3060W** can only be ordered with bundles.

VOI® Bundles Typical



Icon Legend on page 19

VS6060L4B

Worksurface is Silver Mesh, Low Credenza and Layering Shelf are Harvest, O-Leg Supports and grommets are Platinum Metallic.

QTY	DESCRIPTION	MODEL	LIST PRICE	PRICE EXTENSION
1	Rectangle Worksurface with External Support Channel	HLSLR3060W*	\$484	\$484
2	O-Leg Support for Worksurface	HLSL30280	\$363	\$726
1	Low Credenza, Left-hand Drawers	HLSL2060LL2	\$1,286	\$1,286
1	Layering Shelf	HLSL1460LS	\$372	\$372
TOTAL:			\$2,868	

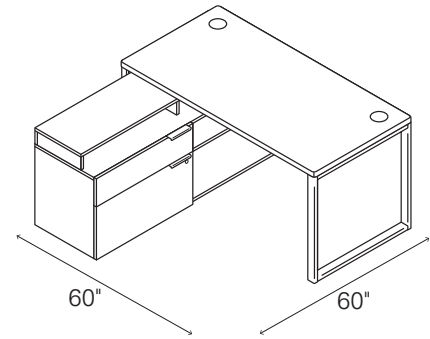

**SMALL FOOTPRINT L-STATION
(LEFT HANDED, LOW CREDENZA)**

VS6060L5B

Worksurface is Silver Mesh, Low Credenza and Overhead Cabinet are Harvest, O-Leg Supports and grommets are Platinum Metallic.

QTY	DESCRIPTION	MODEL	LIST PRICE	PRICE EXTENSION
1	Rectangle Worksurface with External Support Channel	HLSLR3060W*	\$484	\$484
2	O-Leg Support for Worksurface	HLSL30280	\$363	\$726
1	Low Credenza, Right-hand Drawers	HLSL2060LR2	\$1,286	\$1,286
1	Overhead Cabinet with 4 Doors	HLSL1460D	\$1,185	\$1,185
1	O-Leg Support for Overhead Cabinet (Pair)	HLSL650S	\$483	\$483
TOTAL:			\$4,164	

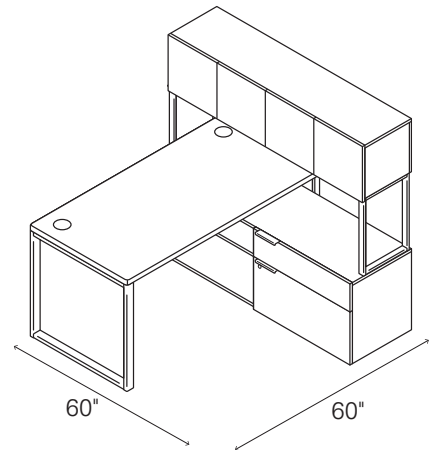

**SMALL FOOTPRINT L-STATION
(RIGHT HANDED, LOW CREDENZA)**

VS6060L3B

Worksurface is Silver Mesh, Low Credenza and Overhead Cabinet are Harvest, O-Leg Supports and grommets are Platinum Metallic.

QTY	DESCRIPTION	MODEL	LIST PRICE	PRICE EXTENSION
1	Rectangle Worksurface with External Support Channel	HLSLR3060W*	\$484	\$484
2	O-Leg Support for Worksurface	HLSL30280	\$363	\$726
1	Low Credenza, Left-hand Drawers	HLSL2060LL2	\$1,286	\$1,286
1	Overhead Cabinet with 4 Doors	HLSL1460D	\$1,185	\$1,185
1	O-Leg Support for Overhead Cabinet (Pair)	HLSL650S	\$483	\$483
TOTAL:			\$4,164	

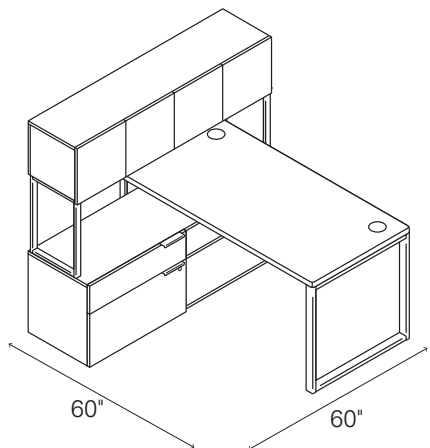

**SMALL FOOTPRINT L-STATION
(LEFT HANDED, LOW CREDENZA)**

*Worksurface model **HLSLR3060W** can only be ordered with bundles.



Icon Legend on page 19

VOI® Bundles Typicals

VS6060L2B

Worksurface is Silver Mesh, Low Credenza and Layering Shelf are Harvest, O-Leg Supports and grommets are Platinum Metallic.

QTY	DESCRIPTION	MODEL	LIST PRICE	PRICE EXTENSION
1	Rectangle Worksurface with External Support Channel	HLSLR3060W*	\$484	\$484
2	O-Leg Support for Worksurface	HLSL30280	\$363	\$726
1	Low Credenza, 2 File/2 Box	HLSL2060LD4	\$1,500	\$1,500
1	Layering Shelf	HLSL1460LS	\$372	\$372
TOTAL:			\$3,082	

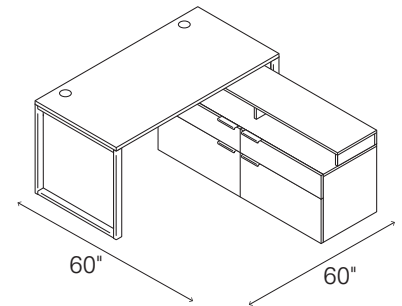

**SMALL FOOTPRINT L-STATION
(LOW CREDENZA, LAYERING SHELF)
(NON-HANDED)**

VC7260L2B

Worksurface is Silver Mesh, Low Credenza is Harvest, O-Leg Supports and grommets are Platinum Metallic.

QTY	DESCRIPTION	MODEL	LIST PRICE	PRICE EXTENSION
1	Rectangle Worksurface with External Support Channel	HLSLR3072W*	\$562	\$562
2	O-Leg Support for Worksurface	HLSL30280	\$363	\$726
1	Low Credenza, 2 File/2 Box	HLSL2060LD4	\$1,500	\$1,500
TOTAL:			\$2,788	

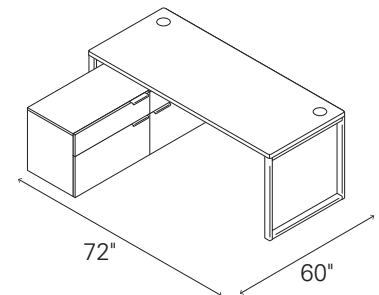

**CONTEMPORARY L-STATION
(NON-HANDED)**

*Worksurface models **HLSLR3060W** and **HLSLR3072W** can only be ordered with bundles.

VOI® SPECIFYING/DESIGN GUIDE

This Specifying Guide is designed to walk you through the steps when choosing the Voi desks elements that will meet your particular workplace needs. From private office to open plan, there are endless combinations that will fit your style and need.

Regardless of the application, Voi presents an integrated, unified aesthetic for the entire workplace.

The step-by-step instructions make it easy to specify elements that personalize workspaces and achieve the right mix of functionality and style.

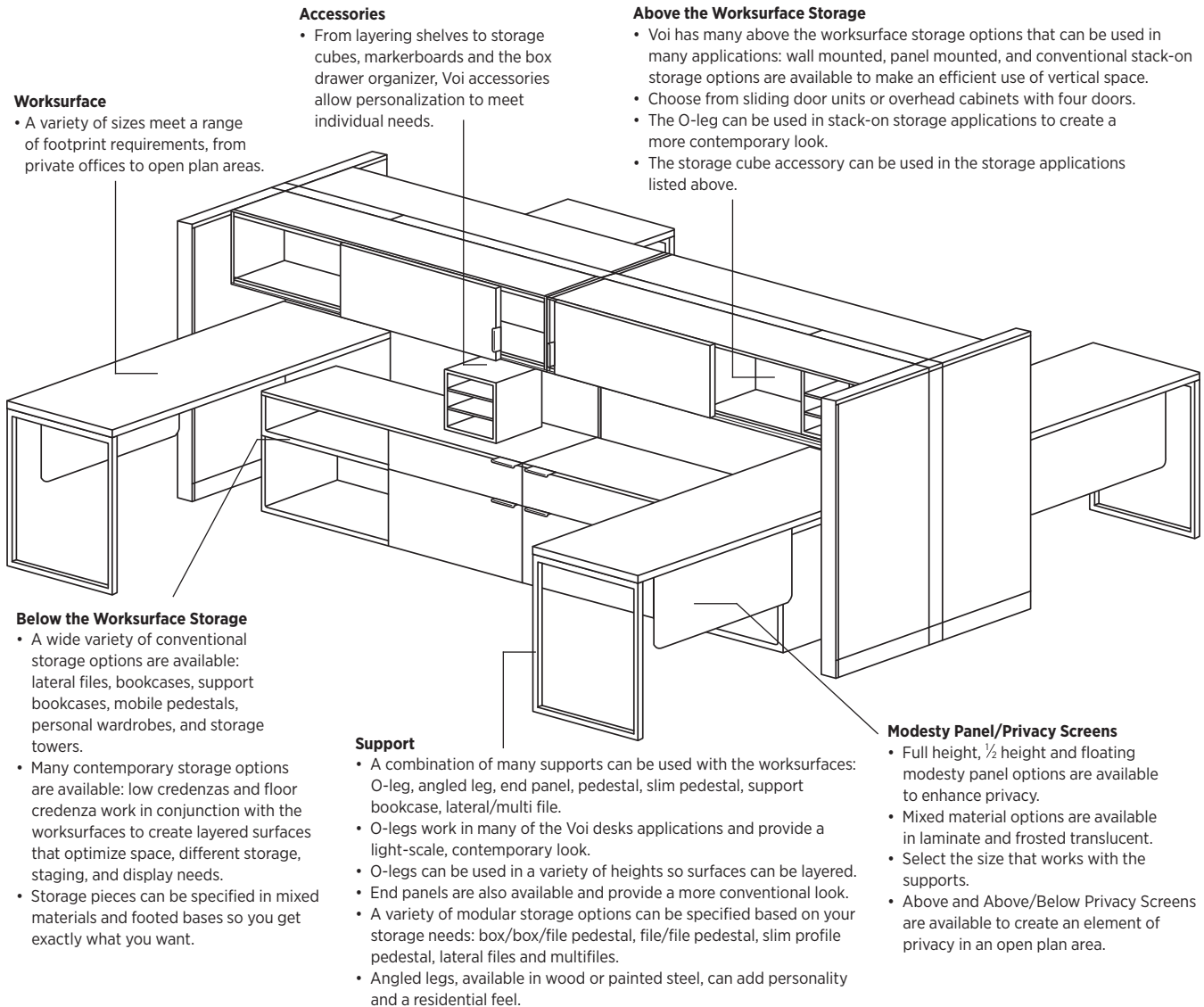

Worksurface

- A variety of sizes meet a range of footprint requirements, from private offices to open plan areas.

Accessories

- From layering shelves to storage cubes, markerboards and the box drawer organizer, Voi accessories allow personalization to meet individual needs.

Above the Worksurface Storage

- Voi has many above the worksurface storage options that can be used in many applications: wall mounted, panel mounted, and conventional stack-on storage options are available to make an efficient use of vertical space.
- Choose from sliding door units or overhead cabinets with four doors.
- The O-leg can be used in stack-on storage applications to create a more contemporary look.
- The storage cube accessory can be used in the storage applications listed above.

Below the Worksurface Storage

- A wide variety of conventional storage options are available: lateral files, bookcases, support bookcases, mobile pedestals, personal wardrobes, and storage towers.
- Many contemporary storage options are available: low credenzas and floor credenza work in conjunction with the worksurfaces to create layered surfaces that optimize space, different storage, staging, and display needs.
- Storage pieces can be specified in mixed materials and footed bases so you get exactly what you want.

Support

- A combination of many supports can be used with the worksurfaces: O-leg, angled leg, end panel, pedestal, slim pedestal, support bookcase, lateral/multi file.
- O-legs work in many of the Voi desks applications and provide a light-scale, contemporary look.
- O-legs can be used in a variety of heights so surfaces can be layered.
- End panels are also available and provide a more conventional look.
- A variety of modular storage options can be specified based on your storage needs: box/box/file pedestal, file/file pedestal, slim profile pedestal, lateral files and multifiles.
- Angled legs, available in wood or painted steel, can add personality and a residential feel.

Modesty Panel/Privacy Screens

- Full height, ½ height and floating modesty panel options are available to enhance privacy.
- Mixed material options are available in laminate and frosted translucent.
- Select the size that works with the supports.
- Above and Above/Below Privacy Screens are available to create an element of privacy in an open plan area.

Steps for specification:

1. Select the right worksurface.
Choose the worksurface shape and size that best fits your office layout.

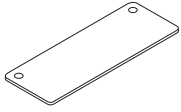

Rectangle Flat Edge Worksurface
Depths: 20", 24", 30", 36"
Widths: 36", 42", 48", 54",
60", 66", 72", 84"

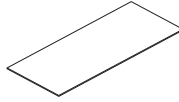

Rectangle Knife Edge Worksurface
Depths: 24", 30"
Widths: 48", 60", 72"

2. Select the supports.
Countless combinations of support options meet a variety of support and storage needs.

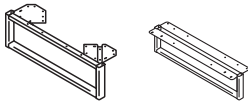

O-Leg and Shared Support for Low Credenza
20"D x 7"H, 24"D x 7"H, 30"D x 7"H
7"H only O-legs attach to worksurface and sit on top of credenzas.

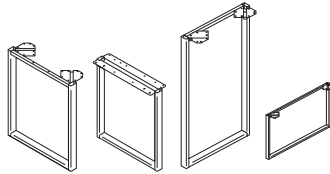

O-Leg and Shared Support for Worksurfaces
20"D x 28½"H, 24"D x 28½"H, 30"D x 28½"H
28½"H, 24"D x 41"H, 30"D x 41"H, 48"D x 28½"H,
60"D x 28½"H O-legs provide support for the worksurface.

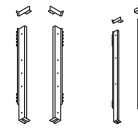

O-Leg-to-Panel Attachment Bracket
Left handed bracket (quantity 1)
Right handed bracket (quantity 1)

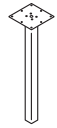

Post Leg
28½"H, 2" square

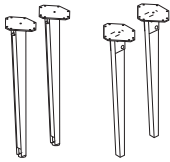

Angled Legs
12"W x 8"D x 32"H, Steel
12"W x 8"D x 32"H, Wood

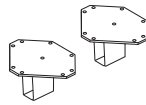

Steel Stanchions
4"H
Stanchions attach to worksurface and sit on top of credenzas.

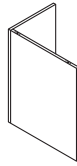

End Panel Support
16"W x 20"D x 28½"H,
16"W x 24"D x 28½"H,
16"W x 30"D x 28½"H

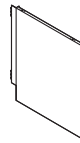

Laminate End Panel Support With Panel Attachment Bracket
24"D x 28½"H, 30"D x 28"H

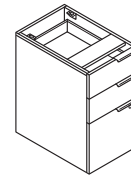

B/B/F Pedestals
16"W x 20"D x 28½"H,
16"W x 24"D x 28½"H,
16"W x 30"D x 28½"H

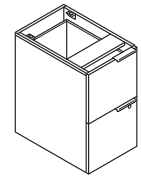

F/F Pedestals
16"W x 20"D x 28½"H,
16"W x 24"D x 28½"H,
16"W x 30"D x 28½"H

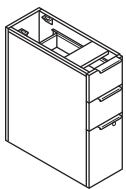

B/B/F Standard Slim Profile Pedestals
9½"W x 24"D x 28½"H,
9½"W x 30"D x 28½"H

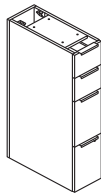

Standing-Height Pedestals
9½"W x 24"D x 41"H,
9½"W x 30"D x 41"H

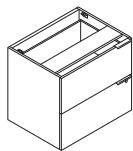

2 Drawer Lateral with Pulls
30"W x 24"D x 28½"H

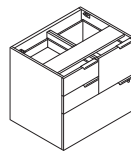

Multi-Drawer Standard File Center
30"W x 24"D x 28½"H

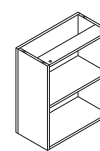

Bookcase Support
30"W x 12"D x 28½"H,
24"W x 12"D x 28½"H

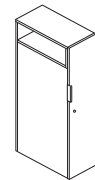

Standing-Height Towers
12"W x 30"D x 50"H,
12"W x 24"D x 50"H

Tips

- When using an O-leg in open plan, panel supported, applications, you must specify an O-leg to panel attachment bracket separately (available in 28"H and 41"H).
- Bookcase Support can only be used exterior facing.
- Telescoping ball-bearing slides used on box and file drawers. Lateral drawers use a progressive ball-bearing slide.
- When specifying a 30"D support on a 36"D worksurface, there will be a 6" overhang.
- All modular pedestals have an easy attach method to the worksurface for quick assembly.
- One double-depth O-leg can replace two regular O-legs in teaming applications.
- Shared O-legs create cleaner aesthetic where two legs are used side-by-side.
- 2" adjustable glides on O-leg supports.
- Standing-Height Support Pedestals bottom two file drawers are locking.
- Standing-Height Bookcase Support contains easy-access, fixed storage shelves.

VOI® SPECIFYING/DESIGN GUIDE

3. Select the modesty panel/privacy screen that works in conjunction with the supports you have specified.

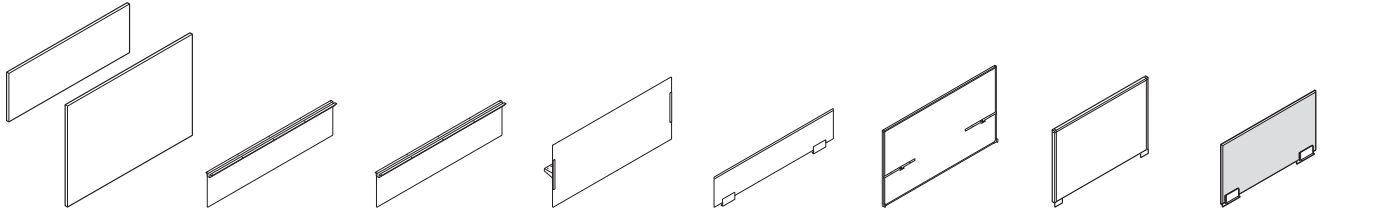

<p>14"H Full Width/ Half-height Laminate Modesty Panel 28", 34", 40"W (Modesty Size) 28"H Full-to-Floor/ Full-Length Laminate Modesty Panel 28", 34", 40"W (Modesty Size)</p>	<p>Laminate Floating Modesty Panel 30"W x 14"H, 36"W x 14"H, 42"W x 14"H, 48"W x 14"H, 54"W x 14"H, 60"W x 14"H</p>	<p>Mixed Material Floating Modesty Panel 30"W x 14"H, 36"W x 14"H, 42"W x 14"H, 48"W x 14"H, 54"W x 14"H, 60"W x 14"H Available in Frosted Translucent only</p>	<p>Above/Below Privacy Screen 30"W x 28"H, 36"W x 28"H, 42"W x 28"H, 48"W x 28"H, 54"W x 28"H, 60"W x 28"H Available in Frosted Translucent only</p>	<p>Above Privacy Screen 30"W x 13"H, 36"W x 13"H, 42"W x 13"H, 48"W x 13"H, 54"W x 13"H, 60"W x 13"H Available in Frosted Glass only</p>	<p>Above/Below Fabric Screen 36"W x 35"H, 42"W x 35"H, 48"W x 35"H, 54"W x 35"H, 60"W x 35"H, 66"W x 35"H, 72"W x 35"H</p>	<p>Above Fabric Screen 20"W x 20"H, 20"W x 13"H, 24"W x 20"H, 24"W x 13"H, 30"W x 20"H, 30"W x 13"H, 36"W x 20"H, 36"W x 13"H</p>	<p>Above Polymer or Glass (Side) Screen 20"W x 13"H, 24"W x 13"H, 30"W x 13"H, 36"W x 13"H</p>
---	--	--	---	---	---	--	---

- Tips**
- Mixed material and laminate floating modesty panels create a lighter scale look by attaching to the top of the worksurface.
 - Choose from a variety of materials to create your desired look.
 - Laminate modesty panels to create a more conventional look.
 - 54"W and 60"W Floating Modesty panels eliminate the need for an external channel.
 - Above Privacy Screens provide a division between two worksurfaces and create a division of space in an open plan area.
 - Modesty panels cannot be used as a support.
 - See modesty panel chart to choose proper modesty size depending on support options.

4. Select Above the Worksurface Storage (Stack-on Storage) or Overhead Cabinets
Select the above the worksurface storage that meets your storage criteria, choose from overhead cabinets, panel mounted storage, conventional or contemporary stack-on storage.

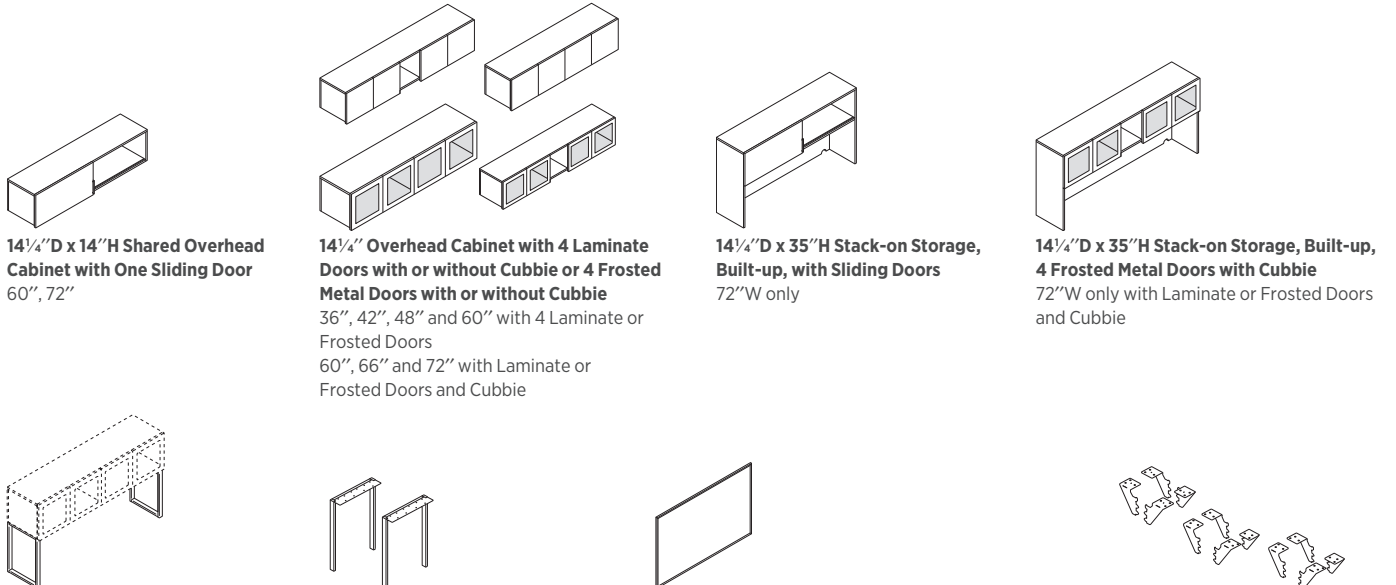

<p>14 1/4" D x 14" H Shared Overhead Cabinet with One Sliding Door 60", 72"</p>	<p>14 1/4" Overhead Cabinet with 4 Laminate Doors with or without Cubbie or 4 Frosted Metal Doors with or without Cubbie 36", 42", 48" and 60" with 4 Laminate or Frosted Doors 60", 66" and 72" with Laminate or Frosted Doors and Cubbie</p>	<p>14 1/4" D x 35" H Stack-on Storage, Built-up, with Sliding Doors 72" W only</p>	<p>14 1/4" D x 35" H Stack-on Storage, Built-up, 4 Frosted Metal Doors with Cubbie 72" W only with Laminate or Frosted Doors and Cubbie</p>
<p>O-Leg Support for Overhead Cabinet 50"-14 1/8" D x 5 1/2" H 65"-14 1/8" D x 20 1/2" H</p>	<p>Post Legs for Shared Storage 14" H and 22" H</p>	<p>Tackboard for Overhead Cabinet Applications Tackboard for Built-up Stack-on Storage 72" W only</p>	<p>Panel Mount Bracket for Shared Overhead Abound and Accelerate</p>

- Tips**
- Select sliding or hinged doors.
 - Specify O-leg separately for a contemporary look.
 - Optional storage shelf works in conjunction with the O-leg design to provide additional storage space. Only works with 65"H O-legs.
 - O-legs come in two sizes to make a 50"H or 65"H stack-on storage unit.
 - Wall-mount brackets carry a \$150 upcharge and are specified the model ordering logic.
 - Use shared overhead and attachments in small footprint applications.
 - Shared overhead must be ordered as left or right to determine open storage location.
 - Shared overhead panel mount brackets and overhead post legs allow overhead to span over all panels systems or run down the spine wall, centered on top of the panel.
 - Use the 65"H for a more conventional design. 65"H and 50"H aligns with Abound and Accelerate.
 - Stack-on Storage must be placed over two full-height supports. Cannot be placed over non-supported sections such as returns using a flat bracket or tower-to-worksurface bracket.
 - If the end panel conventional look is preferred, order the built-up stack-on storage models.
 - There are two types of tackboards for use on Overhead Cabinet and Stack-on Storage.

5. Select the right storage.

Choose from a variety of below the worksurface, as well as traditional, storage options.

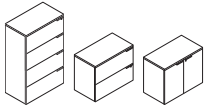

Laterals and Storage Cabinet

2-Drawer Lateral, 4-Drawer Lateral, Storage Cabinet
 36"W x 24"D x 29½"H, 36"W x 20"D x 29½"H,
 36"W x 24"D x 57"H, 36"W x 20"D x 57"H,
 36"W x 24"D x 29½"H, 36"W x 20"D x 29½"H

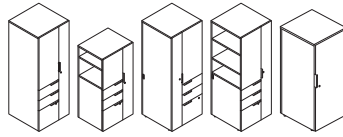

Storage Towers

18"W x 20"D, 18"W x 24"D, 24"W x 20"D, 24"W x 24"D, 50"H and 65"H
Storage Tower, One Door
 18"W x 20"D x 42"H
 Available in Footed Option

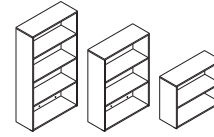

Bookshelves

36"W x 13"D x 29½"H (2 Shelf)
 36"W x 13"D x 50"H (3 Shelf)
 36"W x 13"D x 65"H (4 Shelf)

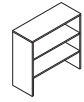

Bookcase Hutch without Doors

36"W x 14"D x 35"H

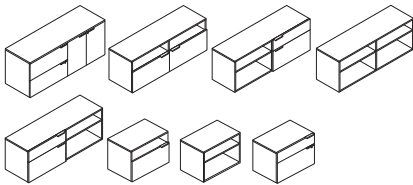

Credenzas

Credenza: 24"D x 72"W x 29½"H
 Low Credenzas: 20"D x 21½"H x 30", 36", 60", 72"W
 Low Credenzas with a variety of door/drawer options
 Limited dimensions available in Footed Option

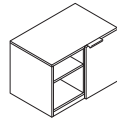

Mobile Credenza

30"W x 20"D x 21½"H

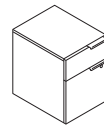

Mobile Pedestal

15¾"W x 20¼"D x 21¼"H
 Available in Footed Option

Tips

- Small credenza models can be used in small footprint applications.
- Can use pedestal or credenza seat cushions on smaller credenza models.
- Low credenzas work in conjunction with worksurface 7" O-leg designed to create a unique layering design.
- Bookcase/laterals and other conventional storage components provide additional storage space.
- Must specify chassis and drawer front color separately.
- Low Credenzas, Laterals and Mobile Pedestals have seat cushions to create additional seating in the workspace.
- Storage and Personal Tower models offer conventional storage as well as wardrobes with a coat rod.
- A worksurface-to-tower bracket kit allows the attachment of worksurfaces to Storage and Personal Tower models.
- Telescoping ball-bearing slides used on box and file drawers. Lateral drawers use a progressive ball-bearing slide.

6. Select Accessories to add color, additional storage and organization to your workspace.

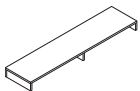

Layering Shelf

60"W x 14¼"D x 5½"H
 72"W x 14¼"D x 5½"H

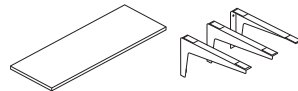

Shelves and Shelf Brackets

Shelf Depth: 13"
 Shelf Widths: 30", 36", 45"
 Bracket sold separately, set of three

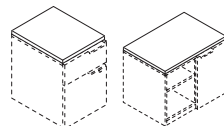

Seat Cushion for Credenzas and Mobile Credenza/Pedestal Pedestal Cushion

15⅞"W x 20"D x 2"H
Credenza Cushion
 20"W x 30"D x 2"H, 20"W x 36"D x 2"H

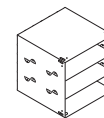

Metal Storage Cube

12" x 12"

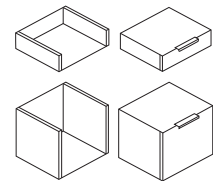

Laminate Storage Cubes

15"W x 13"D x 4"H
 15"W x 13"D x 12"H

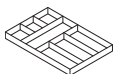

Drawer Organizer

12"W x 14½"D x 1½"H

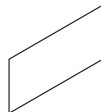

Markerboard for Shared Overhead

30"W x 15"D for use with 60"W Shared Overhead
 36"W x 15"D for use with 72"W Shared Overhead

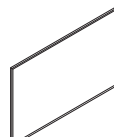

Markerboard

48"W x 31"H



LED Task Light

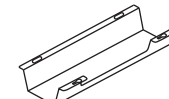

Cable Management Trough

17"W

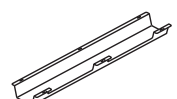

Cable Management Trough

36"W

Tips

- Choose from many bright Storage Cube colors for a colorful design element while providing additional storage.
- Use the Drawer Organizer to keep small items in order. Also offered in the same bright Storage Cube colors.
- Layering shelves are great for filing and piling or in conjunction with the lower credenza.
- Optimize shared overhead capabilities by adding the Markerboard for Shared Overhead.

VOI® SPECIFYING/DESIGN GUIDE

VOI® AND SYSTEMS INTEGRATION

Worksurface Applications

Either Voi or Systems worksurfaces can be used with Voi in an open plan application. There are several support options:

- A. Completely panel supported.
- B. Combination of panel supported and another worksurface support such as:
 - Bookcase support
 - Pedestal (Brigade®, Flagship®, Contain®, or Voi®)
 - Systems open leg
 - Voi O-leg
 - End panel (Systems or Voi)
 - Tower to worksurface bracket
 - Support column
 - Systems round post leg
 - Voi post leg
- C. Freestanding:
 - Bookcase support
 - Two pedestals (Brigade®, Flagship®, Contain®, or Voi®)
 - Two Voi O-legs
 - One Voi O-leg and one Voi O-leg support for lower credenzas
 - Two end panels (metal or Voi)—requires metal or Voi modesty panel
 - Four (Two 2-Pack) Voi angled legs, wood or steel
 - Two Voi angled legs, steel and two Voi steel stanchion supports for low credenzas

Additional application guidelines for worksurfaces:

- Systems worksurfaces are available with grommets or no grommets.
- When Voi lower credenzas are used along the spine wall and are placed adjacent to the wing wall, one electrical/data cutout on the wing wall will be blocked.
- When Voi credenzas are used along the wing wall and are placed adjacent to the spine wall, one electrical/data cutout on the spine wall will be blocked.
- When the Voi O-leg support for credenzas is used, it is recommended to also panel attach the worksurface with the worksurface anti-dislodgement bracket kit HWSA2.
- When the Voi O-leg support is used with panels, it is recommended to also panel attach the O-leg to the panel with the O-leg to panel bracket kit HLSPLB (left) and/or HLSPPB (right). This bracket will provide additional workstation rigidity.
- When the Voi end panel support is used with panels, it is recommended to use the end panel support with panel bracket model. This model will provide additional workstation rigidity.
- The worksurface to tower bracket kit, HSTB2W1, will work with Voi towers, Voi worksurfaces, and systems worksurfaces.
- Knife Edge surfaces are recommended to only use angled post legs as supports.
- Knife Edge worksurfaces are intended to be stand-alone. Surface gaps may occur if connecting to a panel or using return worksurfaces.

Application Guidelines—Combination of Panel Supported and Another Worksurface Support

- For applications where 1) the worksurface is perpendicular to the spine wall; 2) the worksurface is panel supported off the spine wall; and 3) there are Voi credenzas placed under the worksurface along the spine: there is not enough clearance to use standard worksurface cantilevers to attach the worksurface to the spine. Use the worksurface anti-dislodgement bracket kit HWSA2 to panel attach the worksurface in lieu of cantilevers.

Panel Mounted Stack-on Storage Applications

- The Voi stack-on storage cabinets can be used on Abound and Accelerate as panel mounted overheads.
- The sliding door stack-on storage units are available in 36", 42", 48" widths in addition to 60", 66", and 72" widths.
- The 4 door stack-on storage units are only available in 36", 42", 48", 60", 66", and 72" widths.
- The storage units require a storage to panel bracket kit, model HLSLPMB. This model includes one left hand, one right hand, and one center bracket. The brackets are available in all P1 and P2 paint colors.
- The storage cabinets do not have off modular capabilities.
- For proper installation and support, the storage units must follow the following specification rules:
 - There should be a storage unit of the same construction on each side of a given panel.
 - The storage units on opposite sides of a given panel should be in the same location vertically and horizontally.
 - Only one storage unit per panel, per side.
 - The wing panel adjacent to the spine wall needs to be the same height as the spine wall.

Contact HON's Integrated Design Services team with specification questions.



Laminate Worksurfaces — Rectangle

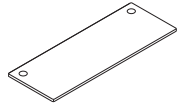

DESCRIPTION	MODEL	SHIP WEIGHT	CUBE	LIST PRICE BY LAMINATE GRADE	
				L1	L2
Rectangle Worksurfaces					
36"W x 20"D	HLSLR2036	40	2.2	\$241	\$251
42"W x 20"D	HLSLR2042	46	2.6	\$268	\$278
48"W x 20"D	HLSLR2048	52	2.9	\$289	\$299
54"W x 20"D	HLSLR2054	64	3.5	\$324	\$339
60"W x 20"D	HLSLR2060	70	3.5	\$356	\$371
66"W x 20"D	HLSLR2066	76	4.2	\$387	\$402
72"W x 20"D	HLSLR2072	82	4.2	\$400	\$415
36"W x 24"D	HLSLR2436	47	2.6	\$252	\$267
42"W x 24"D	HLSLR2442	54	3.0	\$283	\$298
48"W x 24"D	HLSLR2448 Ⓞ	61	3.4	\$306	\$321
54"W x 24"D	HLSLR2454	68	4.2	\$330	\$350
60"W x 24"D	HLSLR2460	75	4.2	\$358	\$378
66"W x 24"D	HLSLR2466	82	5.0	\$389	\$409
72"W x 24"D	HLSLR2472	89	5.0	\$402	\$422
84"W x 24"D	HLSLR2484	103	5.7	\$592	\$617

NOTES:

- Systems worksurfaces can be used with all Voi components.
- Worksurfaces are abrasion- and stain-resistant laminate over durable 1/8" solid core high performance particleboard: resists wrapping.
- There is one 3" grommet in 36"W and 42"W worksurfaces and two in 48"W-84"W worksurfaces.
- One flat bracket ships with each worksurface.
- When attaching tops to panels, refer to Systems section of this pricer.
- Square edge detail.
- When using a floating modesty panel or an external channel under the worksurface, the depth clearance for keyboard trays and center drawers decreases by 8". See accessory matrix in accessory section of the pricer.
- 3" Power Hub model HGRMTAC can be interchanged with 3" standard grommet.
- ! Voi® worksurfaces cannot be used with Abode™ Desks components.
- ! Grommets in worksurfaces must be specified. If grommets are specified, grommets come in predetermined location.
- ! Edgeband option only on all Voi worksurfaces. For edgeband options, see matrix on page 173.
- ! When specifying an 84" Worksurface, cannot use two O-legs, must use at least one additional support such as a pedestal or lateral file.
- ! When using a worksurface as a bridge, no additional supports are needed. One support is required for returns, two supports are required for desks and credenzas.
- ! Lateral file or multi files must be used with surfaces 24"D and 60"W or greater.
- ! Depending on your support combination, an external channel may be required for extra support on unsupported spans greater than 54"W. Please see the matrix on page 192 for more details.
- ! If using a 54"W or 60"W floating modesty, it is not necessary to spec an external channel.
- ! When attaching worksurfaces to panels, one or more of the following are required: anti-dislodgement brackets, end panel, support leg and/or cantilevers. Cantilevers and anti-dislodgement brackets must be ordered separately when attaching worksurfaces to panels.
- ! A return worksurface is considered 48"W or shorter. Longer returns cannot be supported by a flat bracket only.

HOW TO SPECIFY**Select Model Number**

HLSLR2036

Select Worksurface Laminate and Edge Color

See page 173

NN

Select Grommet Option and Color

X No Grommet If choosing the grommet option
G Grommet Select Grommet Color
 See page 173

GT5

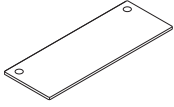

DESCRIPTION	MODEL	SHIP WEIGHT	CUBE	LIST PRICE BY LAMINATE GRADE	
				L1	L2
Rectangle Worksurfaces					
36"W x 30"D	HLSLR3036	58	3.2	\$289	\$304
42"W x 30"D	HLSLR3042	67	3.7	\$311	\$326
48"W x 30"D	HLSLR3048	75	4.2	\$330	\$345
54"W x 30"D	HLSLR3054	84	5.1	\$367	\$387
60"W x 30"D	HLSLR3060	92	5.1	\$410	\$430
66"W x 30"D	HLSLR3066	101	6.1	\$441	\$461
72"W x 30"D	HLSLR3072	110	6.1	\$480	\$500
84"W x 30"D	HLSLR3084	127	7.0	\$654	\$679
60"W x 36"D	HLSLR3660	110	6.1	\$514	\$539
66"W x 36"D	HLSLR3666	120	7.2	\$555	\$580
72"W x 36"D	HLSLR3672	130	7.2	\$623	\$648

NOTES:

- Systems worksurfaces can be used with all Voi components.
- Worksurfaces are abrasion- and stain-resistant laminate over durable 1/8" solid core high performance particleboard; resists wrapping.
- There is one 3" grommet in 36"W and 42"W worksurfaces and two in 48"W-84"W worksurfaces.
- One flat bracket ships with each worksurface.
- When attaching tops to panels, refer to Systems section of this pricer.
- Square edge detail.
- When using a floating modesty panel or an external channel under the worksurface, the depth clearance for keyboard trays and center drawers decreases by 8". See accessory matrix in accessory section of the pricer.
- 3" Power Hub model HGRMTAC can be interchanged with 3" standard grommet.
- Voi® worksurfaces cannot be used with Abode™ Desks components.
- Grommets in worksurfaces must be specified. If grommets are specified, grommets come in predetermined location.
- Edgeband option only on all Voi worksurfaces.
- When specifying an 84" Worksurface, cannot use two O-legs, must use at least one additional support such as a pedestal or lateral file.
- When using a worksurface as a bridge, no additional supports are needed. One support is required for returns, two supports are required for desks and credenzas.
- Lateral file or multi files must be used with surfaces 24"D and 60"W or greater.
- Depending on your support combination, an external channel may be required for extra support on unsupported spans greater than 54"W. Please see page 192 for models and a matrix to aid in specifying.
- If using a 54"W or 60"W floating modesty, it is not necessary to spec an external channel.
- When attaching worksurfaces to panels, one or more of the following are required: anti-dislodgement brackets, end panel, support leg and/or cantilevers. Cantilevers and anti-dislodgement brackets must be ordered separately when attaching worksurfaces to panels.
- A return worksurface is considered 48"W or shorter. Longer returns cannot be supported by a flat bracket only.

HOW TO SPECIFY

<p>Select Model Number</p> <p>HLSLR3036</p>	<p>Select Worksurface Laminate and Edge Color</p> <p>See page 173</p> <p>NN</p>	<p>Select Grommet Option and Color</p> <p>X No Grommet If choosing the grommet option G Grommet Select Grommet Color See page 173</p> <p>GT5</p>
--	--	---

Laminate Worksurfaces — Rectangle

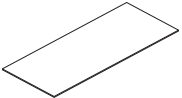
	DESCRIPTION	MODEL	SHIP WEIGHT	CUBE	LIST PRICE BY LAMINATE GRADE	
					L1	L2
	Rectangle Worksurfaces Top with Knife Edge					
	48"W x 24"D	HLSLR2448J	54	3.4	\$420	\$435
	60"W x 24"D	HLSLR2460J	75	4.2	\$489	\$509
	72"W x 24"D	HLSLR2472J	89	5.0	\$550	\$570
	48"W x 30"D	HLSLR3048J	75	4.2	\$451	\$466
	60"W x 30"D	HLSLR3060J	92	5.1	\$561	\$581
	72"W x 30"D	HLSLR3072J	110	6.1	\$656	\$676

NOTES:

- Systems worksurfaces can be used with all Voi® components.
- Worksurfaces are abrasion- and stain-resistant laminate over durable 1½" solid core high performance particleboard: resists wrapping.
- There are two 3" grommets in Knife Edge worksurfaces, if specified.
- When using a floating modesty panel or an external channel under the worksurface, the depth clearance for keyboard trays and center drawers decreases by 8". See accessory matrix in accessory section of the pricer.
- 3" Power Hub model HGRMTAC can be interchanged with 3" standard grommet.
- ! Voi® worksurfaces cannot be used with Abode™ Desks components.
- ! Grommets in worksurfaces must be specified. If grommets are specified, grommets come in predetermined location.
- ! Depending on your support combination, an external channel may be required for extra support on unsupported spans greater than 54"W. Please see the matrix on page 192 for more details.
- ! If using a 54"W or 60"W floating modesty, it is not necessary to spec an external channel.
- ! Voi® Knife Edge surfaces are recommended to only use angled post legs as supports.
- ! Knife Edge worksurfaces are intended to be stand-alone. Surface gaps may occur if connecting to a panel or using return worksurfaces.

HOW TO SPECIFY

Select Model Number <div style="border: 1px solid black; padding: 2px; display: flex; gap: 5px;"> HLSLR2448J </div>	Select Worksurface Laminate and Edge Color See page 173 <div style="border: 1px solid black; padding: 2px; display: flex; gap: 5px;"> NN </div>	Select Grommet Option and Color X No Grommet G Grommet If choosing the grommet option, select Grommet Color. See page 173. <div style="border: 1px solid black; padding: 2px; display: flex; gap: 5px;"> GT1 </div>
---	--	---

VOI® Worksurface Supports

GSA SIN 33721



Icon Legend on page 19

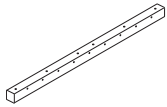

DESCRIPTION

External Support Channel
 42"W for a 54" Worksurface
 48"W for a 60" Worksurface
 54"W for a 66" Worksurface
 60"W for a 72" Worksurface
 72"W for an 84" Worksurface

MODEL

SHIP WEIGHT

CUBE

LIST PRICE

HLSLZ5SC54 ©	5	0.5	\$93
HLSLZ5SC60	6	0.5	\$98
HLSLZ5SC66	7	0.5	\$101
HLSLZ5SC72	7	0.5	\$110
HLSLZ5SC84	12	0.7	\$110

- ! Available in Graphite paint only.
- ! When specifying panel-hung worksurfaces, specify external channel as if supported by two O-legs via selection chart.
- ! When specifying a 54"W or 60"W Floating Modesty Panel, it is not necessary to specify an external channel.

EXTERNAL CHANNEL SELECTION GUIDE

Support Combination		Worksurface Width for Rectangle, Wedge, and Saddle				
Support 1	Support 2	84 in	72 in	66 in	60 in	54 in
O-Leg	O-Leg	NA	HLSLZ5SC72	HLSLZ5SC66	HLSLZ5SC60	HLSLZ5SC54
O-Leg	Slim Profile Pedestal	HLSLZ5SC84	HLSLZ5SC66	HLSLZ5SC60	HLSLZ5SC54	NA
O-Leg	Bookcase	HLSLZ5SC72	HLSLZ5SC66	HLSLZ5SC60	HLSLZ5SC54	NA
O-Leg	Pedestal	HLSLZ5SC72	HLSLZ5SC60	HLSLZ5SC54	NA	NA
O-Leg	End-Panel	HLSLZ5SC84	HLSLZ5SC60	HLSLZ5SC54	NA	NA
Slim Profile Pedestal	Slim Profile Pedestal	HLSLZ5SC72	HLSLZ5SC60	HLSLZ5SC54	NA	NA
Slim Profile Pedestal	Bookcase	HLSLZ5SC72	HLSLZ5SC60	HLSLZ5SC54	NA	NA
Slim Profile Pedestal	Pedestal	HLSLZ5SC66	HLSLZ5SC54	NA	NA	NA
Slim Profile Pedestal	End-Panel	HLSLZ5SC66	HLSLZ5SC54	NA	NA	NA
Pedestal	Bookcase	HLSLZ5SC66	HLSLZ5SC54	NA	NA	NA
End-Panel	Bookcase	HLSLZ5SC66	HLSLZ5SC54	NA	NA	NA
Bookcase	Bookcase	HLSLZ5SC66	HLSLZ5SC54	NA	NA	NA
End-Panel	End-Panel	HLSLZ5SC60	NA	NA	NA	NA
Pedestal	Pedestal	HLSLZ5SC60	NA	NA	NA	NA
Pedestal	End-Panel	HLSLZ5SC60	NA	NA	NA	NA
O-Leg	Lateral/Multifile	HLSLZ5SC54	NA	NA	NA	NA
Bookcase	Lateral/Multifile	NA	NA	NA	NA	NA
Slim Profile Pedestal	Lateral/Multifile	NA	NA	NA	NA	NA
Pedestal	Lateral/Multifile	NA	NA	NA	NA	NA
End-Panel	Lateral/Multifile	NA	NA	NA	NA	NA

*All Rudder worksurfaces use external channel model HLSLZ5SC60.

HOW TO SPECIFY

<p>Select Model Number</p> <p>H L S L Z 5 S C 8 4 . P</p>	<p>Select Paint Color</p> <p>See page 173</p>
--	--

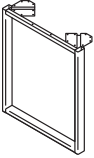
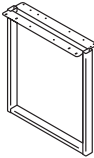
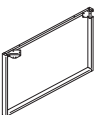
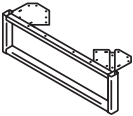
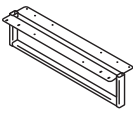

	DESCRIPTION	MODEL	SHIP WEIGHT	CUBE	LIST PRICE BY PAINT GRADE		
					P1	P2	P3
	O-Leg Support for Worksurfaces						
	20"D x 28½"H	HLSL2028O	15	3.7	\$298	\$302	\$318
	24"D x 28½"H	HLSL2428O	17	3.7	\$324	\$328	\$344
	30"D x 28½"H	HLSL3028O ☺	19	5.4	\$359	\$363	\$379
	NOTES: Ship fully assembled, 1/pack. Non-handed.						
	! Specify paint only.						
	SPECIFYING EXAMPLE: HLSL2028O.T1						
	O-Leg Shared Support for Worksurfaces						
	20"D x 28½"H	HLSL2028SL	15	3.7	\$356	\$360	\$376
	24"D x 28½"H	HLSL2428SL	17	3.7	\$402	\$406	\$422
	30"D x 28½"H	HLSL3028SL ☺	19	5.4	\$447	\$451	\$467
	NOTES: Ship fully assembled, 1/pack. Non-handed.						
	! Specify paint only.						
	SPECIFYING EXAMPLE: HLSL2028SL.T1						
	Double-Depth O-Leg Support for Worksurfaces						
	48"D x 28½"H	HLSL4828O	18	7.0	\$610	\$618	\$630
	60"D x 28½"H	HLSL6028O	19	8.7	\$679	\$687	\$699
	NOTES: Ship fully assembled, 1/package. Non-handed.						
	O-Leg Support for Low Credenzas						
	20"D x 7"H	HLSL207O	5	1.0	\$201	\$205	\$221
	24"D x 7"H	HLSL247O	6	1.0	\$218	\$222	\$238
	30"D x 7"H	HLSL307O ☺	7	1.0	\$277	\$281	\$297
	NOTES: Ship fully assembled, 1/pack. Non-handed.						
	! Specify paint only.						
	SPECIFYING EXAMPLE: HLSL207O.T1						
	O-Leg Shared Support for Low Credenzas						
	20"D x 7"H	HLSL207SL	5	1.0	\$250	\$254	\$270
	24"D x 7"H	HLSL247SL	6	1.0	\$272	\$276	\$292
	30"D x 7"H	HLSL307SL	7	1.0	\$344	\$348	\$364
	NOTES: Ship fully assembled, 1/pack. Non-handed.						
	! Specify paint only.						
	SPECIFYING EXAMPLE: HLSL207SL.T1						

NOTES:

- A variety of pedestals, end panels, and O-legs can be combined to create a conventional or contemporary desk.
- O-leg ships fully assembled with mounting hardware.
- Shared O-Legs create a cleaner aesthetic in all applications where two legs are used side-by-side.
- Shared O-Leg bracket will span both worksurfaces to provide the same support with the look of a single O-leg.
- Will have a 6" overhang when using 30" worksurface supports with a 36"D worksurface.
- Glides on O-Leg Support for Worksurfaces and Post Leg Base have 2" of adjustability. No glides on 7"H O-leg. Glides on end panels have 1¼" adjustability.

! O-legs may only be attached to worksurfaces, not storage units.

HOW TO SPECIFY

Select Model Number HLSL2028O	Select Paint Color See page 173 T1
---	---

VOI® Worksurface Supports

GSA SIN 33721

Icon Legend on page 19

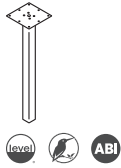

DESCRIPTION

Post Leg Base
28½”H x 2” square

MODEL

HLSL28P

SHIP WEIGHT

15

CUBE

1.0

LIST PRICE BY PAINT GRADE

P1

\$298

P2

\$302

P3

\$318

- ⓘ Post leg cannot be used on primary worksurface with an O-leg as the other support.
- ⓘ Post leg can only be used to support peninsula, not as primary supports for a top.

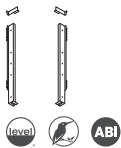

28½”H O-Leg-to-Panel Attachment Bracket

28½”H Left handed bracket (quantity 1)
28½”H Right handed bracket (quantity 1)

HLSLPBL

3 Ⓢ

0.4

\$100

\$104

N/A

HLSLPBR

3 Ⓢ

0.4

\$100

\$104

N/A

NOTES: Used to connect Voi O-Leg to a systems panel for additional workstation rigidity. Bracket designed to work with edgeband worksurfaces only. Brackets are handed, come one per package and include self-tapping screws. Specify paint.

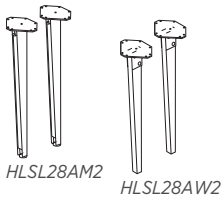

Angled Legs

12”W x 8”D x 32”H Steel — 2-Pack
12”W x 8”D x 32”H Wood — 2-Pack

HLSL28AM2 ⓘ

15 Ⓢ

1.3

\$323

\$331

\$343

HLSL28AW2

14 Ⓢ

1.5

\$420

NOTES: Angled Steel Legs come equipped with a removable wire management channel in each leg.

- ⓘ 4”H Stanchions to be used on floor storage with feet ONLY.
- ⓘ O-Leg Support to be used on floor storage without feet ONLY.
- ⓘ Wood legs use natural wood material. The color on each leg may contain natural variation.
- ⓘ Pricing shown is per carton. Ordering 2 of either model will result in 2 cartons being shipped, giving you 4 legs.

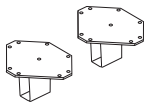

Steel Stanchions — 2-Pack

4”H

HLSL4AM2

5 Ⓢ

0.2

\$151

\$159

\$171

- ⓘ 4”H Stanchions to be used on floor storage with feet ONLY.
- ⓘ O-Leg Support to be used on floor storage without feet ONLY.
- ⓘ Wood legs use natural wood material. The color on each leg may contain natural variation.
- ⓘ Pricing shown is per carton. Ordering 2 of either model will result in 2 cartons being shipped, giving you 4 legs.

DESCRIPTION	MODEL	SHIP WEIGHT	CUBE	LIST PRICE BY LAMINATE GRADE	
				L1	L2
End Panel Support 16”W x 20”D x 28½”H 16”W x 24”D x 28½”H 16”W x 30”D x 28½”H NOTES: Ship in two pieces.	HLSL2028E	39	3.2	\$193	\$203
	HLSL2428E	44	3.7	\$207	\$217
	HLSL3028E	50	4.2	\$221	\$231

NOTES:

- A variety of pedestals, end panels, and O-legs can be combined to create a conventional or contemporary desk.
- Voi® square support column is interchangeable with the Systems worksurface round support column: HCNLEG29.
- Glides on Post Leg Base have 2” of adjustability. Glides on end panels have 1¼” adjustability.

HOW TO SPECIFY

<p>Select Model Number</p> <p>H L S L 2 0 2 8 E . H</p>	<p>Select Laminate/Paint</p> <p>See page 173</p>
---	--



Standing-Height Worksurface Supports

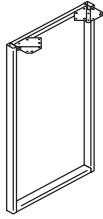

DESCRIPTION

Standing-Height O-Leg Support for Worksurfaces

24"D x 41"H
30"D x 41"H

MODEL

HLSL24410
HLSL30410

SHIP WEIGHT CUBE

16 5.3
17 6.5

LIST PRICE BY PAINT GRADE

P1 P2 P3

\$433 \$439 \$453
\$485 \$491 \$505

NOTES: Ship fully assembled, 1/package. Non-handed.
Coordinate™ Power Modules will work with standing-height applications for 10500™ and Voi® desks. Please see Coordinate™ Accessories Stand-Alone Pricer pages for more information.

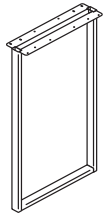

Standing-Height O-Leg Shared Support for Worksurfaces

24"D x 41"H
30"D x 41"H

HLSL2441SL
HLSL3041SL

16 5.3
17 6.5

\$488 \$494 \$508
\$540 \$546 \$560

NOTES: Ship fully assembled, 1/package. Non-handed.
Coordinate™ Power Modules will work with standing-height applications for 10500™ and Voi® desks. Please see Coordinate™ Accessories Stand-Alone Pricer pages for more information.



Standing-Height O-Leg to Panel Attachment Bracket

41"H Left-hand Bracket
41"H Right-hand Bracket

HLSLSPBL
HLSLSPBR

6 1.0
6 1.0

\$127 \$131 N/A
\$127 \$131 N/A

NOTES: 1/package. Brackets are handed as shown above. To be used with 41"H O-legs shown above (HLSL24410 and HLSL30410).

NOTES:

- O-leg glides have 2" adjustability.
- O-Leg to Panel Attachment Brackets are used to connect Voi® O-Legs to a systems panel for additional worksurface rigidity.
- ! O-legs may only be attached to worksurfaces, not storage units.

HOW TO SPECIFY

Select Model Number	Select Paint Color
	See page 173
HLSL24410	T1

VOI® Standing-Height Laminate Support

GSA SIN 33721



Icon Legend on page 19

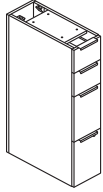

DESCRIPTION	MODEL	SHIP WEIGHT	CUBE	L1 LIST	L2 UPCHARGES	
					CHASSIS	FRONTS
Standing-Height Support Pedestals — Box/Box/File/File						
9½"W x 24"D x 41"H	HL2441S	94	11.9	\$1510	\$40	\$20
9½"W x 30"D x 41"H	HL3041S	113	14.7	\$1569	\$45	\$20

NOTES: Top two drawers are non-locking.

❗ Cannot use grommet worksurfaces with Standing-Height Support Storage.

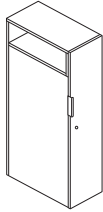

DESCRIPTION	MODEL	SHIP WEIGHT	CUBE	L1 LIST	L2 UPCHARGES	
					CHASSIS	FRONTS
Standing-Height Side Access Storage Tower						
12"W x 24"D x 50"H - Left	HL2450L	100	11.0	\$1376	\$35	\$20
12"W x 24"D x 50"H - Right	HL2450R	100	11.0	\$1376	\$35	\$20
12"W x 30"D x 50"H - Left	HL3050L	121	13.6	\$1435	\$35	\$20
12"W x 30"D x 50"H - Right	HL3050R	121	13.6	\$1435	\$35	\$20

NOTES:

- Tower includes coat hook on back of door.
- Chassis and drawer front panels can be specified separately.
- Tower door is locking. Ships with one handle.
- Support Pedestals bottom file drawers will lock, top box drawers will not.
- Standing-Height Pedestals will have 6" overhang when using 30"D support storage with a 36"D worksurface.
- Use the worksurface to tower bracket kit model HSTB2W1 on page 220 to attach worksurfaces to the Storage Tower models.

❗ Pedestals ship fully assembled but must attach to a worksurface with a quick release bracket, provided. Pedestals are non-handed and are interchangeable.

❗ Locking units equipped with HON "One Key" interchangeable core removable locks. Keyed alike core must be ordered separately.

HOW TO SPECIFY

Select Model Number See page 173 HL2441S	Select Chassis Laminate See page 173 N	Select Drawer Front Laminate See page 173 N	Select Pull Color See page 173 T4
--	--	---	---

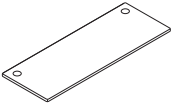
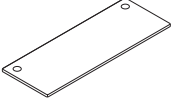

Coordinate™ Sit-to-Stand Worksurfaces

	DESCRIPTION	MODEL	SHIP WEIGHT	CUBE	LIST PRICE BY LAMINATE GRADE	
					L1	L2
	Rectangle Worksurfaces					
	48"W x 24"D	HLSLR2448 ☉	61	3.4	\$306	\$321
	54"W x 24"D	HLSLR2454	68	4.2	\$330	\$350
	60"W x 24"D	HLSLR2460	75	4.2	\$358	\$378
	66"W x 24"D	HLSLR2466	82	5.0	\$389	\$409
	72"W x 24"D	HLSLR2472	89	5.0	\$402	\$422
	Rectangle Worksurfaces					
	48"W x 30"D	HLSLR3048	75	4.2	\$330	\$345
	54"W x 30"D	HLSLR3054	84	5.1	\$367	\$387
	60"W x 30"D	HLSLR3060 ☉	92	5.1	\$410	\$430
	66"W x 30"D	HLSLR3066 ☉	101	6.1	\$441	\$461
	72"W x 30"D	HLSLR3072 ☉	110	6.1	\$480	\$500

HOW TO SPECIFY

Select Model Number

HLSLR2448

Select Worksurface Laminate and Edge Color

See page 173

NN

Select Grommet Option and Color

X No Grommet If choosing the grommet option
G Grommet Select Grommet Color
 See page 173

GT5

VOI® Height Adjustable Bases

OPEN MARKET



Icon Legend on page 19

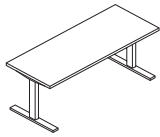

Base shown with work surface attached.

**DESCRIPTION****MODEL****SHIP WEIGHT****CUBE****LIST PRICE****Coordinate™ Height Adjustable Base – 2 Stage**

24"D Feet and Worksurface Brackets

HHAB2S2L

63

2.4

\$1006

NOTES: Base is a dual motor 2-stage design with standard anti-collision. Legs raise from 25⁵/₈" to 45¹/₄". Base telescopes to accommodate any rectangular work surface between 24"D x 42"W and 30"D x 72"W. Supports weight capacity of 250 lbs. (excluding work surface weight). See the Tables section in the 2021 Shared Spaces Pricer for Voi® Worksurfaces. See the Tables section in the 2021 Shared Spaces Pricer for Systems Worksurfaces. For Height Adjustable Base Accessories see the Tables section in the 2021 Shared Spaces Pricer. Concinnity™, Systems, Voi®, 10500, and Preside® all have work surfaces within this range.

- ⓘ When attaching a Keyboard Tray, remember to also specify a Keyboard Spacer Kit (HKBS).
- ⓘ Telescoping horizontal frame will extend just over 2" from underside of the work surface.
- ⓘ Removal of stretcher bars in Coordinate™ base is required when pairing with a 42"W work surface.

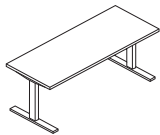
SPECIFYING EXAMPLE: HHAB2S2L.P8L

Base shown with work surface attached.

**Coordinate™ Height Adjustable Base – 3 Stage**

24"D Feet and Worksurface Brackets

HHAB3S2L

67

2.4

\$1120

NOTES: Base telescopes to accommodate any rectangular work surface between 24"D x 42"W and 30"D x 72"W. Supports weight capacity of 250 lbs. (excluding work surface weight). Concinnity™, Systems, Voi®, 10500, and Preside® all have work surfaces within this range. Base is a dual motor 3-stage design with standard anti-collision. Legs raise from 21⁵/₈" to 47³/₄".

- ⓘ Telescoping horizontal frame will extend just over 2" from underside of the work surface.
- ⓘ Removal of stretcher bars in Coordinate™ base is required when pairing with a 42"W work surface.

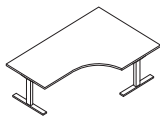

Base shown with work surface attached.

**Coordinate™ 3-Leg Height Adjustable Base – 3 Stage**

24"D Feet and Worksurface Brackets

HHAB3S3L

91

3.6

\$1896

NOTES: Base is a three motor 3-stage design with standard anti-collision. Legs raise from 21⁵/₈" to 47³/₄". The 3-leg base supports corner covers or two-piece work surfaces 41"-72"W x 35"-72"L x 23¹/₄"-30"D. 48"W 120 degree corner work surfaces are also supported. When using two work surfaces, the connection between the two must be over the telescoping frame. Supports weight capacity of 375 lbs. (excluding work surface weight). Can be used with 48" 120 degree and work surface models.

- ⓘ When using two work surfaces, a flat bracket is required. Bracket purchased separately — HHN831124, HHN831130 — see page 607.
- ⓘ Telescoping horizontal frame will extend just over 2" from underside of the work surface.

NOTES:**Coordinate™ Height Adjustable Bases**

- Comes standard with one-touch, four memory controller with digital display; no specification needed, available in black finish only.
- **HON 7-Year Limited Warranty.**

- ⓘ Coordinate™ Height Adjustable Bases not compatible with 36"D rectangular work surfaces.
- ⓘ See page 594 for additional Coordinate™ base models and options.

HOW TO SPECIFY**Select Model Number****Select Finish**





P71 Black
P8L Nickel
PD8 White

H H A B 2 S 2 L .

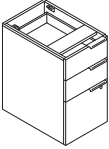

P 8 L

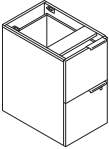
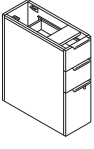

Laminate Support/Support Pedestals

	DESCRIPTION	MODEL	SHIP WEIGHT	CUBE	L1 LIST	L2 UPCHARGES	
						CHASSIS	FRONTS
	Support Pedestals — Box/Box/File						
	16"W x 20"D x 28½"H	HLSL2028B	73	7.3	\$704	\$15	\$10
	16"W x 24"D x 28½"H	HLSL2428B 	85	8.5	\$778	\$20	\$10
	16"W x 30"D x 28½"H	HLSL3028B	105	10.5	\$876	\$25	\$10
	NOTES: Top box drawer does not lock.						
	Support Pedestals — File/File						
	16"W x 20"D x 28½"H	HLSL2028F	72	7.3	\$704	\$15	\$10
	16"W x 24"D x 28½"H	HLSL2428F	84	8.5	\$778	\$20	\$10
	16"W x 30"D x 28½"H	HLSL3028F	104	10.5	\$876	\$25	\$10
	NOTES: Unit is locking.						
	Slim Profile Pedestals — Box/Box/File						
	9½"W x 24"D x 28½"H	HLSL2428S	69	6.9	\$772	\$20	\$10
	9½"W x 30"D x 28½"H	HLSL3028S	56	5.6	\$848	\$25	\$10
	NOTES: Top box drawer does not lock.						
	 Grommet will be located under Slim Pedestal when attached.						

NOTES:

- A variety of pedestals, end panels, and O-legs can be combined to create a conventional or contemporary desk.
- Chassis and drawer front woodgrain and solid laminates are specified separately (see SIF options below).
- Will have a 6" overhang when using 30" worksurface supports with a 36"D worksurface.
- File drawers accept hanging folders in letter or legal size.
- Multiple handle locations possible per customer preference.
- Ships with one handle per drawer.
- Drawer Organizer model HSLDRWORG works with box drawers.
- Box and file drawers operate on ball-bearing suspension with full extension.
- Adjustable hex leveling glides allow floor-standing furniture to be easily leveled without lifting the unit; glides have 1¼" adjustable range.
-  Pedestals ship fully assembled but must attach to a worksurface with a quick release bracket, provided. Pedestals are non-handed and are interchangeable.
-  Locking units equipped with HON "One Key" interchangeable core removable locks. Keyed alike core must be ordered separately.

HOW TO SPECIFY

Select Model Number	Select Chassis Laminate	Select Drawer Front Laminate	Select Pull Color
See page 173	See page 173	See page 173	See page 173
H L S L 2 0 2 8 B .	N .	N .	T 4

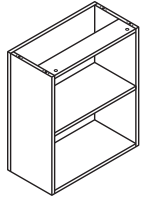
**DESCRIPTION****Bookcase Support**

24"W x 12"D x 28½"H

30"W x 12"D x 28½"H

Specify: Model.Laminate

SPECIFYING EXAMPLE: HLSL24OBC.N**MODEL****HLSL24OBC****HLSL30OBC****SHIP WEIGHT**

60

75

CUBE

3.0

3.0

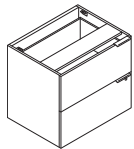
L1 LIST**\$522****\$546****L2 UPCHARGES****\$20****\$25****N/A****N/A****Lateral File — 2 Drawer**

31⅜"W x 24"D x 28½"H

NOTES: Unit is locking.

HLSL2430L

121

15.6

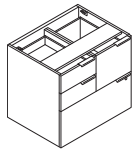
\$1207**\$35****\$20****Multi File Lateral File**

31⅜"W x 24"D x 28½"H

NOTES: Box drawers do not lock.

HLSL2430MF

163

15.6

\$1433**\$35****\$20****NOTES:**

- Ships with one handle per drawer on all units.
- A variety of pedestals, end panels, and O-legs can be combined to create conventional or contemporary desk.
- Bookcase can only mount exterior facing under a worksurface.
- Chassis and drawer front woodgrain and solid laminates are specified separately (see SIF options below).
- File drawers accept hanging folders in letter or legal size.
- Multiple handle locations possible per customer preference.
- Storage accessory model HLSLDRWORG works with box doors.
- Standard box drawers operate on ball-bearing suspension with full extension. File, lateral, and wide box drawers operate on ball-bearing suspension with full extension.
- Adjustable hex leveling glides allow floor-standing furniture to be easily leveled without lifting the unit; glides have 2" adjustable range.
- When using two lateral files, a 60" worksurface cannot be used, a 66" worksurface must be specified, which will show a gap.



! A single multi file or lateral file must be specified under a worksurface 60"W or wider.

! Locking units equipped with HON "One Key" interchangeable core removable locks. Keyed alike core must be ordered separately.

HOW TO SPECIFY

Select Model Number	Select Chassis Laminate	Select Laminate	Select Pull Color
See page 173	See page 173	See page 173	See page 173
H L S L 2 4 3 0 L .	N .	N .	T 4

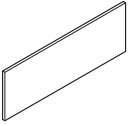
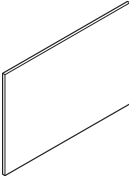
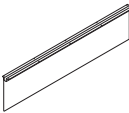

DESCRIPTION	MODEL	SHIP WEIGHT	CUBE	LIST PRICE BY LAMINATE GRADE	
				L1	L2
 <p>Full Width/Half-height Laminate Modesty Panel 28"W x 14"H, for use with 60" desks 34"W x 14"H, for use with 66" desks 40"W x 14"H, for use with 72" desks</p>	HLSL2814LM	19	1.6	\$189	\$199
	HLSL3414LM	23	1.9	\$195	\$205
	HLSL4014LM	29	2.4	\$203	\$213
NOTES: Three sizes available for 60", 66" and 72" desks. Can only be used when using end panels and pedestals for support.					
 <p>Full-to-Floor/Full-Length Laminate Modesty Panel 28"W x 28½"H, for use with 60" desks 34"W x 28½"H, for use with 66" desks 40"W x 28½"H, for use with 72" desks</p>	HLSL2828LM	33	2.7	\$252	\$264
	HLSL3428LM	38	3.2	\$296	\$308
	HLSL4028LM	44	3.6	\$312	\$324
NOTES: Three sizes available for 60", 66" and 72" desks. Can only be used when using end panels and pedestals for support.					
 <p>Laminate Floating Modesty Panel 30"W x 14"H 36"W x 14"H 42"W x 14"H 48"W x 14"H 54"W x 14"H 60"W x 14"H</p>	HLSL3014L	10	0.8	\$173	\$183
	HLSL3614L	12	0.8	\$183	\$193
	HLSL4214L	14	0.8	\$195	\$205
	HLSL4814L	16	1.1	\$215	\$227
	HLSL5414L	18	1.1	\$235	\$247
	HLSL6014L	20	1.1	\$253	\$265
NOTES: The attachment bracket and modesty panel are packaged separately. Specify: Model.Laminate.Paint SPECIFYING EXAMPLE: HLSL3014L.N (Black is the only paint option for this model)  When specifying the 54"W or 60"W Laminate Floating Modesty Panel, it is not necessary to specify an external channel.  30"W and 36"W screens attach with L-brackets, not the external channel.					

NOTES:

- Full width laminate modesty panel (14"H) and full width/full-length laminate modesty panels are designed to work with 60", 66", & 72" desks.
- Laminate and frosted translucent laminate are available options on modesty panels.
- Full height and half height laminate modesty panels can only be used when specifying a pedestal and/or end panel.

HOW TO SPECIFY

Select Model Number HLSL2814LM .	Select Laminate See page 173 N
--	---

VOI® Modesty Panels

GSA SIN 33721

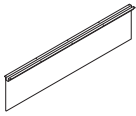

Icon Legend on page 19

**DESCRIPTION****Mixed Material Floating Modesty Panel**

30"W x 14"H
36"W x 14"H
42"W x 14"H
48"W x 14"H
54"W x 14"H
60"W x 14"H

MODEL

HLSL3014MM
HLSL3614MM
HLSL4214MM ☉
HLSL4814MM ☉
HLSL5414MM ☉
HLSL6014MM ☉

SHIP WEIGHT

8
8
9
11
13
13

CUBE

2.0
2.0
2.3
2.6
3.3
3.3

LIST PRICE

\$689
\$739
\$826
\$914
\$992
\$1134

NOTES: The attachment bracket and modesty panel are packaged separately.

Specify: Model.Mixed Material.Paint

SPECIFYING EXAMPLE: HLSL3014MM.FT01 (Frosted Translucent mixed material and Black paint are the only options for this model)

! When specifying the 54"W or 60"W Mixed Material Floating Modesty Panel, it is not necessary to specify an external channel.

NOTES:

- Full width laminate modesty panel (14"H) and full width/full-length laminate modesty panels are designed to work with 60", 66", & 72" desks.
- Laminate and frosted translucent laminate are available options on modesty panels.
- Full height and half height laminate modesty panels can only be used when specifying a pedestal and/or end panel.

FLOATING MODESTY SELECTION GUIDE

Support Combination		Top Size								
Support 1	Support 2	84 in	72 in	66 in	60 in	54 in	48 in	42 in	36 in	30 in
O-Leg/Angled Leg	O-Leg/Angled Leg	NA	HLSL6014	HLSL5414	HLSL4814	HLSL4214	HLSL3614	HLSL3014	NA	NA
O-Leg/Angled Leg	Slim Profile Pedestal	HLSL6014	HLSL5414	HLSL4814	HLSL4214	HLSL3614	HLSL3014	NA	NA	NA
O-Leg/Angled Leg	Bookcase	HLSL6014	HLSL5414	HLSL4814	HLSL4214	HLSL3614	HLSL3014	NA	NA	NA
O-Leg/Angled Leg	Pedestal	HLSL6014	HLSL4814	HLSL4214	HLSL3614	HLSL3014	NA	NA	NA	NA
O-Leg/Angled Leg	End-Panel	HLSL6014	HLSL4814	HLSL4214	HLSL3614	HLSL3014	NA	NA	NA	NA
Slim Profile Pedestal	Slim Profile Pedestal	HLSL6014	HLSL4814	HLSL4214	HLSL3614	HLSL3014	NA	NA	NA	NA
Slim Profile Pedestal	Bookcase	HLSL6014	HLSL4814	HLSL4214	HLSL3614	HLSL3014	NA	NA	NA	NA
Slim Profile Pedestal	Pedestal	HLSL5414	HLSL4214	HLSL3614	HLSL3014	NA	NA	NA	NA	NA
Slim Profile Pedestal	End-Panel	HLSL5414	HLSL4214	HLSL3614	HLSL3014	NA	NA	NA	NA	NA
Pedestal	Bookcase	HLSL5414	HLSL4214	HLSL3614	HLSL3014	NA	NA	NA	NA	NA
End-Panel	Bookcase	HLSL5414	HLSL4214	HLSL3614	HLSL3014	NA	NA	NA	NA	NA
Bookcase	Bookcase	HLSL5414	HLSL4214	HLSL3614	HLSL3014	NA	NA	NA	NA	NA
End-Panel	End-Panel	HLSL4814	HLSL3614	HLSL3014	NA	NA	NA	NA	NA	NA
Pedestal	Pedestal	HLSL4814	HLSL3614	HLSL3014	NA	NA	NA	NA	NA	NA
Pedestal	End-Panel	HLSL4814	HLSL3614	HLSL3014	NA	NA	NA	NA	NA	NA
O-Leg/Angled Leg	Lateral/Multifile	HLSL4214	HLSL3614	HLSL3014	NA	NA	NA	NA	NA	NA
Bookcase	Lateral/Multifile	HLSL3614	NA	NA	NA	NA	NA	NA	NA	NA
Slim Profile Pedestal	Lateral/Multifile	HLSL3614	NA	NA	NA	NA	NA	NA	NA	NA
Pedestal	Lateral/Multifile	HLSL3014	NA	NA	NA	NA	NA	NA	NA	NA
End-Panel	Lateral/Multifile	HLSL3014	NA	NA	NA	NA	NA	NA	NA	NA

HOW TO SPECIFY

Select
Model Number

HLSL3014MM.

Select
Mixed Material

FT01 Frosted Translucent

FT01

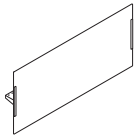

DESCRIPTION

Above/Below Privacy Screen

- 30"W x 28"H
- 36"W x 28"H
- 42"W x 28"H
- 48"W x 28"H
- 54"W x 28"H
- 60"W x 28"H

MODEL SHIP WEIGHT CUBE LIST PRICE

HLSL2830	6	6.4	\$816
HLSL2836	6	6.4	\$1129
HLSL2842	6	6.3	\$1142
HLSL2848	8	8.2	\$1217
HLSL2854	9	8.6	\$1417
HLSL2860	9	8.6	\$1426

NOTES: Attachment bracket extends 2" into the worksurface. Brackets are Platinum only, no need to specify.

! Available in Frosted Translucent Acrylic ONLY HLSL2830.FT01.

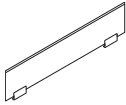

Above Privacy Screen

- 30"W x 13"H
- 36"W x 13"H
- 42"W x 13"H
- 48"W x 13"H
- 54"W x 13"H
- 60"W x 13"H

HLSL1230	13	1.5	\$285
HLSL1236	15	1.8	\$314
HLSL1242	18	2.3	\$352
HLSL1248	20	2.3	\$402
HLSL1254	22	2.9	\$430
HLSL1260	24	2.9	\$462

NOTES: Bracket is Platinum only, no need to specify.

! Available in Frosted Glass ONLY HLSL1230.G.

! Above only Privacy Screen clamps onto worksurface and cannot be installed where support storage will be attached.

NOTES:

- Ships complete with attachment brackets.
- Voi® Privacy Screens can be used on the HON Height Adjustable Base.
- All brackets are Platinum.
- Above Privacy Screen attaches to top of worksurface.
- Above and Below Privacy Screen extends 13" above and 13" below the worksurface.
- ! Above/Below Privacy Screens cannot be used with Knife Edge worksurfaces.

ABOVE-BELOW PRIVACY SCREEN SELECTION GUIDE

Support Combination		Top Size								
Support 1	Support 2	84 in	72 in	66 in	60 in	54 in	48 in	42 in	36 in	30 in
O-Leg/Angled Leg	O-Leg/Angled Leg	NA	HLSL2860	HLSL2854	HLSL2848	HLSL2842	HLSL2836	HLSL2830	NA	NA
O-Leg/Angled Leg	Slim Profile Pedestal	HLSL2860	HLSL2854	HLSL2848	HLSL2842	HLSL2836	HLSL2830	NA	NA	NA
O-Leg/Angled Leg	Bookcase	HLSL2860	HLSL2854	HLSL2848	HLSL2842	HLSL2836	HLSL2830	NA	NA	NA
O-Leg/Angled Leg	Pedestal	HLSL2860	HLSL2848	HLSL2842	HLSL2836	HLSL2830	NA	NA	NA	NA
O-Leg/Angled Leg	End-Panel	HLSL2860	HLSL2848	HLSL2842	HLSL2836	HLSL2830	NA	NA	NA	NA
Slim Profile Pedestal	Slim Profile Pedestal	HLSL2860	HLSL2848	HLSL2842	HLSL2836	HLSL2830	NA	NA	NA	NA
Slim Profile Pedestal	Bookcase	HLSL2860	HLSL2848	HLSL2842	HLSL2836	HLSL2830	NA	NA	NA	NA
Slim Profile Pedestal	Pedestal	HLSL2854	HLSL2842	HLSL2836	HLSL2830	NA	NA	NA	NA	NA
Slim Profile Pedestal	End-Panel	HLSL2854	HLSL2842	HLSL2836	HLSL2830	NA	NA	NA	NA	NA
Pedestal	Bookcase	HLSL2854	HLSL2842	HLSL2836	HLSL2830	NA	NA	NA	NA	NA
End-Panel	Bookcase	HLSL2854	HLSL2842	HLSL2836	HLSL2830	NA	NA	NA	NA	NA
Bookcase	Bookcase	HLSL2854	HLSL2842	HLSL2836	HLSL2830	NA	NA	NA	NA	NA
End-Panel	End-Panel	HLSL2848	HLSL2836	HLSL2830	NA	NA	NA	NA	NA	NA
Pedestal	Pedestal	HLSL2848	HLSL2836	HLSL2830	NA	NA	NA	NA	NA	NA
Pedestal	End-Panel	HLSL2848	HLSL2836	HLSL2830	NA	NA	NA	NA	NA	NA
O-Leg/Angled Leg	Lateral/Multifile	HLSL2842	HLSL2836	HLSL2830	NA	NA	NA	NA	NA	NA
Bookcase	Lateral/Multifile	HLSL2836	NA	NA	NA	NA	NA	NA	NA	NA
Slim Profile Pedestal	Lateral/Multifile	HLSL2836	NA	NA	NA	NA	NA	NA	NA	NA
Pedestal	Lateral/Multifile	HLSL2830	NA	NA	NA	NA	NA	NA	NA	NA
End-Panel	Lateral/Multifile	HLSL2830	NA	NA	NA	NA	NA	NA	NA	NA

HOW TO SPECIFY

Select Model Number

HLSL2830 .

HLSL1230 .

Select Mixed Material

FT01 Frosted Translucent Acrylic
Specified for Above/Below Privacy Screens only

G Frosted Glass
Specified for Above Privacy Screens only

FT01

G

VOI® Privacy Screens

GSA SIN 33721

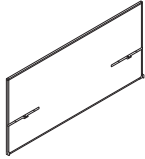

Icon Legend on page 19

**DESCRIPTION****Above/Below Fabric Privacy Screen**

36"W x 35"H
42"W x 35"H
48"W x 35"H
54"W x 35"H
60"W x 35"H
66"W x 35"H
72"W x 35"H

MODEL

HLSL3635TS
HLSL4235TS
HLSL4835TS
HLSL5435TS
HLSL6035TS
HLSL6635TS
HLSL7235TS

SHIP WEIGHT

21
27
33
39
45
51
57

CUBE

3.8
4.4
6.0
6.0
6.0
7.4
7.4

CORE LIST PRICE BY CODE**A**

\$882
\$926
\$986
\$1030
\$1094
\$1153
\$1203

B

\$907
\$951
\$1021
\$1065
\$1137
\$1196
\$1246

NOTES: Brackets are Platinum only, no need to specify. Above/Below Privacy Screens must be ordered the same width as the worksurface it is being used with to properly attach.

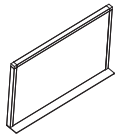
**Above Fabric (Side) Privacy Screen**

20"W x 20"H
24"W x 20"H
30"W x 20"H
36"W x 20"H

HLSL2020TS
HLSL2024TS
HLSL2030TS
HLSL2036TS

13 Ⓞ
15 Ⓞ
17 Ⓞ
19 Ⓞ

1.4
1.4
1.9
2.2

\$342
\$352
\$368
\$406

\$349
\$360
\$379
\$419

20"W x 13"H
24"W x 13"H
30"W x 13"H
36"W x 13"H

HLSL1220TS
HLSL1224TS
HLSL1230TS
HLSL1236TS

11 Ⓞ
13 Ⓞ
15 Ⓞ
17 Ⓞ

1.1
1.1
1.6
1.9

\$326
\$333
\$348
\$369

\$332
\$339
\$355
\$377

NOTES: Brackets are Platinum only, no need to specify. Brackets intended to be attached between users sitting side-by-side, and will create 1/8" separation between worksurfaces.

NOTES:

- Ships complete with attachment brackets.
 - All brackets are Platinum.
 - Above Privacy Screen attaches to top and side of worksurface with adhesive banding.
 - Lower attachment brackets may be shifted to attach to support components.
 - Above/Below Privacy Screen extends 20" above and 13" below worksurface.
- ❗ Screens cannot be used with T-mold on series such as tables. Screens can only attach to edgeband. Surfaces must be cleaned prior to adhering the screen and must be left to cure for 24 hours without touching for best adhesion.
- ❗ Above/Below Fabric Privacy Screens can attach to worksurfaces that are either O-leg supported on both sides, or worksurfaces that are supported by a support pedestal on one side and an O-leg on the other. They cannot be attached to worksurfaces supported by support pedestals on both sides, unless additional hardware is specified.
- ❗ Above Screens must attach to edgeband and top of surface.
- ❗ Above/Below Privacy Screens must be ordered the same width as the worksurface it is being used with to properly attach.
- ❗ Above/Below Privacy Screens cannot be used with Knife Edge worksurfaces.
- ❗ Shared O-legs should not be used with Above/Below Fabric Privacy Screens.

HOW TO SPECIFY

Select
Model Number

HL S L 3 6 3 5 T S .

Select
Fabric

See pages 25-26

P N 1 5

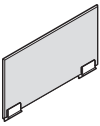
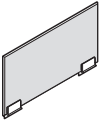

	DESCRIPTION	MODEL	SHIP WEIGHT	CUBE	LIST PRICE
	Above Frosted Polymer (Side) Privacy Screen				
	20"W x 13"H	HLSL1220FS	12	1.3	\$315
	24"W x 13"H	HLSL1224FS	14	1.4	\$336
	30"W x 13"H	HLSL1230FS	16	1.6	\$363
	36"W x 13"H	HLSL1236FS	19	1.9	\$406
	NOTES: Brackets are Platinum only, no need to specify. Brackets intended to be attached between users sitting side-by-side, and will create 1/8" separation between worksurfaces.				
	Above Frosted Glass (Side) Privacy Screen				
	20"W x 13"H	HLSL1220GS	13	1.3	\$263
	24"W x 13"H	HLSL1224GS	16	1.4	\$280
	30"W x 13"H	HLSL1230GS	18	1.6	\$303
	36"W x 13"H	HLSL1236GS	20	1.9	\$338
	NOTES: Brackets are Platinum only, no need to specify. Brackets intended to be attached between users sitting side-by-side, and will create 1/8" separation between worksurfaces.				

NOTES:

- Above Privacy Screens are intended to be attached between users sitting side-by-side but will create 1/8" spacing between the worksurfaces. Please consider stack up if using in a panel-wrapped application.
- Ships complete with attachment brackets.
- All brackets are Platinum.
- Above Privacy Screen attaches to top and side of worksurface with adhesive banding.
- Lower attachment brackets may be shifted to attach to support components.
- Above/Below Privacy Screen extends 20" above and 13" below worksurface.
- ❗ Screens cannot be used with T-mold on series such as tables. Screens can only attach to edgeband. Surfaces must be cleaned prior to adhering the screen and must be left to cure for 24 hours without touching for best adhesion.

HOW TO SPECIFY

<p>Select Model Number</p> <p>HLSL1220FS</p> <p>HLSL1220GS</p>	<p>Select Mixed Material</p> <p>FT01 Frosted Translucent Acrylic Specified for Above Screen models HLSL1220FS-HLSL1236FS only</p> <p>G Frosted Glass Specified for Above Screen models HLSL1220GS-HLSL1236GS only</p> <p>FT01</p> <p>G</p>
---	---

VOI® Laminate Overhead Storage

GSA SIN 33721



Icon Legend on page 19

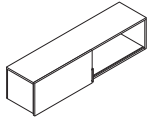

DESCRIPTION	MODEL	SHIP WEIGHT	CUBE	L1 LIST	L2 UPCHARGES	
					CABINET	DOOR
Overhead Cabinet with One Sliding Door						
36"W x 14¼"D x 14"H	HLSL1436S	39	9.7	\$1020	\$25	\$20
42"W x 14¼"D x 14"H	HLSL1442S	48	9.7	\$1069	\$25	\$20
48"W x 14¼"D x 14"H	HLSL1448S	57	12.1	\$1100	\$25	\$20
60"W x 14¼"D x 14"H	HLSL1460S	69	13.3	\$1185	\$30	\$25
66"W x 14¼"D x 14"H	HLSL1466S	83	14.6	\$1308	\$30	\$25
72"W x 14¼"D x 14"H	HLSL1472S	95	15.9	\$1428	\$35	\$25

NOTES:

- Sliding door overhead does not ship with a pull — door overhangs chassis to slide.

HOW TO SPECIFY

Select Model Number	Select Cabinet Laminate	Select Door Laminate	Select Pull Option	Specify Bracket Option
For locking overhead models, add an "L" suffix (\$40 upcharge per model)	See page 173	See page 173	X No Pull	X No Bracket W Wall Bracket (\$150 upcharge)
H L S L 1 4 7 2 S .	N .	N .	X .	W

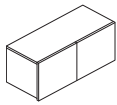

DESCRIPTION	MODEL	SHIP WEIGHT	CUBE	L1 LIST	L2 UPCHARGES	
					CABINET	DOOR
Overhead Cabinet with Doors						
36"W x 14¼"D x 14"H, 2 doors	HLSL1436D	39	9.7	\$860	\$25	\$20
42"W x 14¼"D x 14"H, 2 doors	HLSL1442D	48	9.7	\$957	\$25	\$20
48"W x 14¼"D x 14"H, 3 doors	HLSL1448D	57	12.1	\$1062	\$25	\$30
60"W x 14¼"D x 14"H, 4 doors	HLSL1460D	115	13.3	\$1185	\$30	\$30

❗ 2-Door and 3-Door Overhead Cabinet with Doors models HLSL1436D–HLSL1448D available in laminate only. The 60" model HLSL1460D is available in all door finish options—see "Select Door Material for 2/3/4 Door Models" below.

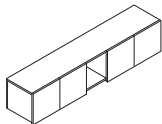

DESCRIPTION	MODEL	SHIP WEIGHT	CUBE	L1 LIST	L2 UPCHARGES	
					CABINET	DOOR
Overhead Cabinet with 4 Doors/Cubbies						
66"W x 14¼"D x 14"H with 6" Cubbie	HLSL1466D	126	14.6	\$1308	\$30	\$30
72"W x 14¼"D x 14"H with 12" Cubbie	HLSL1472D	139	15.9	\$1428	\$35	\$35

NOTES: Doors available in laminate or mixed materials.

NOTES:

- All Overhead Cabinets shown above can be used as a wall mount, panel mount or stack-on storage with O-leg.
- Tackboards are available for wall mount storage applications and conventional stack-on. Use wall mount tackboards when using O-leg supports.
- 5½"H and 20½"H O-legs can be purchased to create stack-on storage. Heights line up with Abound® and Accelerate® panels.
- Overhead cabinets with four doors are available in laminate or mixed materials.
- Wall mount brackets specified with unit. Brackets attach to case horizontally.
- Storage cases accept binder height items.
- The Metal Storage Cube HLSL1212 fits inside stack-on storage or overhead cabinet units to provide paper management.
- For panel mounted applications, brackets and hardware are ordered separately, see pages 556-557. Brackets attach to panel and case is screwed into brackets. Two brackets needed for 60" unit.

❗ Stack-on Storage must be placed over two full-height supports. Cannot be placed over non-supported sections such as returns using a flat bracket or tower-to-worksurface bracket.

❗ T1G doors not available with a locking option.

HOW TO SPECIFY

Select Model Number	Select Cabinet Laminate	Select Door Material for 2/3/4 Door Models	Select Bracket Option
For locking overhead models, add an "L" suffix (\$40 upcharge per model)	See page 173	Upcharge for door selection: 4-Door \$315 T1G Platinum Polymer with Frosted glass Also available in laminate doors. See page 173. Not specified for models HLSL1436D–HLSL1448D. These models are available in laminate only.	X No Bracket W Wall Bracket (\$150 upcharge)
H L S L 1 4 6 0 D .	N .	T 1 G .	X

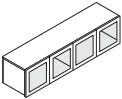
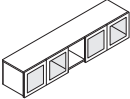
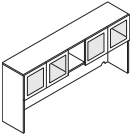

Laminate Overhead and Stack-on Storage

	DESCRIPTION	MODEL	SHIP WEIGHT	CUBE	LIST PRICE BY LAMINATE GRADE	
					L1	L2
	Overhead Cabinet with 4 Frosted, Metal Frame Doors 60"W x 14¼"D x 14"H	HLSL1460M	115	11.4	\$1950	\$1980
	! Must specify an X or W for attachment bracket option below.					
	Overhead Cabinet with 4 Frosted, Metal Frame Doors 72"W x 14¼"D x 14"H with 12" Cubbie	HLSL1472M	139	13.6	\$2198	\$2233
	66"W x 14¼"D x 14"H with 6" Cubbie	HLSL1466M	126	12.5	\$2073	\$2103
	! Must specify an X or W for attachment bracket option below.					
	Stack-on Storage, Built-up with 4 Frosted Doors with Metal Frame with Cubbies 72"W x 14¼"D x 35"H with 12" Cubbie	HLSL1472MB	165	30.4	\$2315	\$2360
	NOTES: Ships complete with Back Enclosure and laminate End Panels. Ships factory assembled.					
	! Does not require bracket specification.					





	DESCRIPTION	MODEL	SHIP WEIGHT	CUBE	LIST PRICE BY FABRIC GRADE	
					A	B
 18½"H	Tackboard for Wall Mount Overhead Cabinets					
	For 78"W	HLSL78TW	13	1.4	\$383	\$395
	For 72"W	HLSL72TW	12	1.4	\$364	\$376
	For 66"W	HLSL66TW	11	1.4	\$349	\$361
	For 60"W	HLSL60TW	10	1.1	\$310	\$322
	For 48"W	HLSL48TW	13	1.4	\$270	\$280
	For 42"W	HLSL42TW	12	1.4	\$251	\$261
	For 36"W	HLSL36TW	11	1.4	\$237	\$247
	SPECIFYING EXAMPLE: HLSL48TW.DB30					

NOTES:

- Use O-Leg Support models for Overhead Cabinets. See page 209.
- The Metal Storage Cube HLSL1212 fits inside stack-on storage or wall mount units to provide paper management. See page 209.
- ! Metal Frame Overhead and Stack-on Storage units are not available with a lock.
- ! Stack-on Storage must be placed over two full-height supports. Cannot be placed over non-supported sections such as returns using a flat bracket or tower-to-worksurface bracket.
- ! Specify fabric, see pages 25-26. Upcharges may apply to premium fabric grades. Analog (ANLG), Disperse (DISP), and Exchange (EXG) not available on sizes wider than 72".

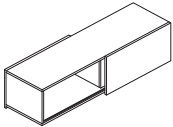
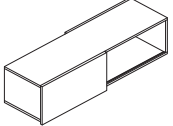
HOW TO SPECIFY

Select Model Number	Select Cabinet Laminate See page 173	Select Door Material TIG Platinum Metal Doors with Frosted Glass (no upcharge)	Select Bracket Option X No Bracket W Wall Bracket (\$150 upcharge) Not specified for model HLSL1472MB
HLSL1460M	N	TIG	X

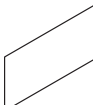
	DESCRIPTION	MODEL	SHIP WEIGHT	CUBE	L1 LIST	L2 UPCHARGES	
						CABINET	DOOR
	Shared Overhead Storage — Left						
	60"W x 17"D x 14"H 72"W x 17"D x 14"H	HLSL1760SOL HLSL1772SOL	115 139	14.8 17.0	\$1302 \$1570	\$20 \$25	\$40 \$40
	Shared Overhead Storage — Right						
	60"W x 17"D x 14"H 72"W x 17"D x 14"H	HLSL1760SOR HLSL1772SOR	115 139	14.8 17.0	\$1302 \$1570	\$20 \$25	\$40 \$40
	DESCRIPTION	MODEL	SHIP WEIGHT	CUBE	LIST PRICE BY PAINT GRADE		
					P1	P2	P3
	Post Legs for Shared Storage						
	14"H Post Legs 22"H Post Legs	HLSL140SPL HLSL220SPL	10 Ⓢ 13 Ⓢ	1.1 3.7	\$346 \$384	\$350 \$388	\$366 \$404
NOTES: 14"H post legs on worksurfaces will span 35"H panel or shorter. 14"H post legs on low credenzas will span 30"H panel or shorter. 22"H post legs on worksurfaces will span 50"H panel or shorter. 22"H post legs on low credenzas will span 35"H panel or shorter. Specify paint. SPECIFYING EXAMPLE: HLSL140SPL.T4							
  	Panel Mount Bracket for Shared Overhead						
	Panel Mount Bracket for Overhead Storage — Accelerate®	HLSLPMBSOA	4 Ⓢ	0.1	\$136	\$140	N/A
	Panel Mount Bracket for Overhead Storage — Abound®	HLSLPMBSOB	4 Ⓢ	0.1	\$136	\$140	N/A
	Panel Mount Bracket for Overhead Storage — Accelerate®/Abound® 42½"H panels only	HLSLPMBSO42	4 Ⓢ	0.1	\$127	\$131	N/A
NOTES: Specify paint. SPECIFYING EXAMPLE: HLSLPMBSOA.T4							
	Markerboard for Shared Storage						
	30"W x 13"H for use with 60"W Shared Overhead 36"W x 13"H for use with 72"W Shared Overhead	HLSL1530SOMB HLSL1536SOMB	6 Ⓢ 8 Ⓢ	1.0 1.0	\$132 \$179		
NOTES: No specification necessary.							

NOTES:

- Overall case depth is 19"D including the sliding door.
- Use Shared Overhead and attachments in small footprint applications.
- Sliding door is 15"H, providing a 1" valance below the case which can be used as a finger pull if desired.
- Shared Overhead panel mount brackets and overhead post legs allow overhead to span over all panels systems or run down the spine wall, centered on top of the panel.
- Post legs can attach to all low credenza models and all worksurface models.
- Markerboard insert is markerboard laminate with black edges, no frame.

ⓘ Shared Overhead must be ordered as left or right to determine open storage location.

ⓘ Shared Overhead Storage is not available with a lock.

HOW TO SPECIFY

Select Model Number HLSL1760SOL	Select Chassis Laminate See page 173 N	Select Door Front Laminate See page 173 N
Select Model Number HLSL140SPL	Select Paint Color See page 173 T4	

Overhead Storage Supports/Accessories

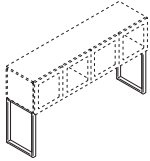

DESCRIPTION	MODEL	SHIP WEIGHT	CUBE	LIST PRICE BY PAINT GRADE		
				P1	P2	P3
O-Leg Support for Overhead Cabinet Ships 2/pack 14 7/8" D x 20 1/2" H	HLSL650S	8	1.1	\$479	\$483	\$499
14 7/8" D x 5 1/2" H	HLSL500S	6	1.0	\$398	\$402	\$418

NOTES: 20 1/2" H legs used to reach 65" H when overhead storage is stacked on top of a worksurface. 5 1/2" H legs used to reach 50" H when overhead storage is stacked on top of a worksurface. O-leg ships fully assembled with mounting hardware. O-legs can be used with all overhead cabinet models. See pages 206 and 207.

⚠ Not for use on Shared Overhead Storage, use post leg models on page 208.

⚠ Stack-on Storage must be placed over two full-height supports. Cannot be placed over non-supported sections such as returns using a flat bracket or tower-to-worksurface bracket.

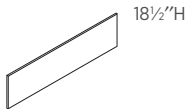

DESCRIPTION	MODEL	SHIP WEIGHT	CUBE	LIST PRICE BY FABRIC GRADE	
				A	B
Wall Mounted Tackboards For 78" W	HLSL78TW	13	1.4	\$383	\$395
For 72" W	HLSL72TW	12	1.4	\$364	\$376
For 66" W	HLSL66TW	11	1.4	\$349	\$361
For 60" W	HLSL60TW	10	1.1	\$310	\$322
For 48" W	HLSL48TW	13	1.4	\$270	\$280
For 42" W	HLSL42TW	12	1.4	\$251	\$261
For 36" W	HLSL36TW	11	1.4	\$237	\$247

NOTES: Specify fabric, see pages 25-26. Upcharges may apply to premium fabric grades. Analog (ANLG), Disperse (DISP), and Exchange (EXG) not available on sizes wider than 72".

SPECIFYING EXAMPLE: HLSL78TW.APN23



DESCRIPTION	MODEL	SHIP WEIGHT	CUBE	LIST PRICE
Storage Cube 12" W x 12" D	HLSL1212	1	0.3	\$294

SPECIFYING EXAMPLE: HLSL1212.P8S

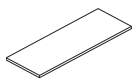

DESCRIPTION	MODEL	SHIP WEIGHT	CUBE	L1 LIST PRICE	L2 UPCHARGE
Shelves 30" W x 13" D	HLSLR1330	10 Ⓞ	1.3	\$191	\$10
36" W x 13" D	HLSLR1336	12 Ⓞ	1.5	\$214	\$10
45" W x 13" D	HLSLR1345	15 Ⓞ	1.9	\$232	\$10

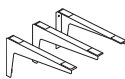

DESCRIPTION	MODEL	SHIP WEIGHT	CUBE	LIST PRICE BY PAINT GRADE		
				P1	P2	P3
Shelf Bracket (set of 3)	HLSLSB	3 Ⓞ	0.2	\$96	\$104	\$116

HOW TO SPECIFY

<p>Select Model Number</p> <p>H L S L 6 5 0 S .</p>	<p>Select Laminate/Paint</p> <p>See page 173</p> <p>T 1</p>
---	---

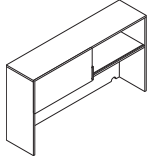

DESCRIPTION	MODEL	SHIP WEIGHT	CUBE	L1 LIST	L2 UPCHARGES	
					CABINET	DOOR
Stack-on Storage, Built-up, with Sliding Doors 72"W x 14¼"D x 35"H NOTES: Ships complete with Back Enclosure and laminate End Panels. Ships factory assembled.	HLSL1472SB	139	30.4	\$1553	\$45	\$20

HOW TO SPECIFY

Select Model Number HLSL1472SB	Select Cabinet Laminate See page 173 L2 (\$45 upcharge) N	Select Door Laminate See page 173 L2 (\$20 upcharge) N	Select Pull Option <input checked="" type="checkbox"/> No Pull
--	---	--	--

DESCRIPTION	MODEL	SHIP WEIGHT	CUBE	L1 LIST	L2 UPCHARGES	
					CABINET	DOOR
Stack-on Storage, Built-up, with 4 Doors/Cubbies 72"W x 14¼"D x 35"H with 12" Cubbie NOTES: Ships complete with Back Enclosure and laminate End Panels. Ships factory assembled.	HLSL1472DB	144	30.4	\$1553	\$45	N/A

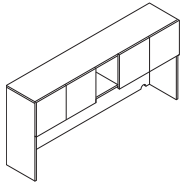

DESCRIPTION	MODEL	SHIP WEIGHT	CUBE	LIST PRICE BY FABRIC GRADE	
				A	B
Tackboard for Built-up Stack-on Storage For 72" NOTES: For a list of standard fabrics, see pages 25-26. For a complete list of fabrics, please go to hon.com/fabricsandfinishes. Analog (ANLG), Disperse (DISP), and Exchange (EXG) not available on sizes wider than 72". SPECIFYING EXAMPLE: HLSL7265TE.APN23	HLSL7265TE	12	1.4	\$364	\$376

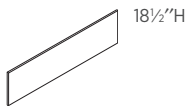

NOTES:

- The Metal Storage Cube HLSL1212 fits inside stack-on storage or wall mount units to provide paper management.
- Stack-on Storage is not available with a lock.
- Tackboards are available for Built-up models only. Tackboards cannot be added to O-leg supported units.
- Stack-on Storage must be placed over two full-height supports. Cannot be placed over non-supported sections such as returns using a flat bracket or tower-to-worksurface bracket.

HOW TO SPECIFY

Select Model Number HLSL1472DB	Select Cabinet Chassis Laminate See page 173 L2 (\$45 upcharge) N	Select Door Material for 4-Door Models Upcharge for door selection: <table border="0" style="width: 100%;"> <tr> <td>T1G Platinum Polymer with Frosted glass</td> <td style="text-align: right;">4-Door \$315</td> </tr> </table> Also available in laminate doors. See page 173.	T1G Platinum Polymer with Frosted glass	4-Door \$315
T1G Platinum Polymer with Frosted glass	4-Door \$315			



	DESCRIPTION	MODEL	SHIP WEIGHT	CUBE	L1 LIST	L2 UPCHARGES	
						CHASSIS	FRONTS
	Low Credenza, 2 File/2 Box 72"W x 20"D x 21½"H 60"W x 20"D x 21½"H NOTES: Unit is locking.	HLSL2072LD4	230	21.9	\$1645	\$40	\$40
		HLSL2060LD4	190	18.9	\$1500	\$35	\$40
	Low Credenza, 2 File Drawers, Open Top 72"W x 20"D x 21½"H 60"W x 20"D x 21½"H NOTES: Unit is non-locking.	HLSL2072LD2	200	21.9	\$1538	\$40	\$30
		HLSL2060LD2 	160	18.9	\$1405	\$35	\$30
	Low Credenza, Left Hand Drawers 72"W x 20"D x 21½"H 60"W x 20"D x 21½"H NOTES: Unit is locking.	HLSL2072LL2	200	21.9	\$1523	\$40	\$20
		HLSL2060LL2	160	18.9	\$1286	\$35	\$20
	Low Credenza, Right Hand Drawers 72"W x 20"D x 21½"H 60"W x 20"D x 21½"H NOTES: Unit is locking.	HLSL2072LR2	200	21.9	\$1523	\$40	\$20
		HLSL2060LR2	160	18.9	\$1286	\$35	\$20
	Low Credenza, Open 72"W x 20"D x 21½"H 60"W x 20"D x 21½"H SPECIFYING EXAMPLE: HLSL2072LDO.Z (model.chassis only)	HLSL2072LDO	170	21.9	\$1294	\$40	N/A
		HLSL2060LDO	130	18.9	\$1075	\$35	N/A
	Low Credenza, 4 Storage Doors 72"W x 20"D x 21½"H 60"W x 20"D x 21½"H NOTES: Unit is locking.	HLSL2072S4	190	21.9	\$1632	\$40	\$40
		HLSL2060S4	160	18.9	\$1402	\$35	\$40

NOTES:

- Worksurfaces with 7" O-legs, may be placed upon low credenzas to create layering.
- Chassis and drawer fronts woodgrains and solid laminates are specified separately (see SIF options below).
- File drawers accept hanging folders in letter size.
- Multiple handle locations possible per customer preference.
- Seat cushions are available for low credenzas and mobile pedestals (specify separately).
- Storage accessory model HLSLDRWORG works with box doors.
- Layering shelf works with low credenzas to provide additional storage areas.
- File, lateral, and wide box drawers operate on ball-bearing suspension with full extension.
- Adjustable hex leveling glides allow floor-standing furniture to be easily leveled without lifting the unit; glides have 1/4" adjustable range.
- Ships with one handle per drawer on all units.

 Locking units equipped with HON "One Key" interchangeable core removable locks. Keyed alike core must be ordered separately.

HOW TO SPECIFY

Select Model Number	Select Chassis Laminate See page 173	Select Drawer Front Laminate See page 173	Select Pull Color See page 173 Not specified for Open Credenza models HLSL2072LDO, HLSL2060LDO
H L S L 2 0 7 2 L D 4 .	N .	N .	T 4

VOI® Laminate Low Credenzas

GSA SIN 33721



Icon Legend on page 19

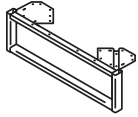

DESCRIPTION	MODEL	SHIP WEIGHT	CUBE	LIST PRICE BY PAINT GRADE		
				P1	P2	P3
7" O-Leg Support for Worksurfaces 30"D x 7"H 24"D x 7"H 20"D x 7"H Specify: Model.Paint HL3070.T1.	HLSL3070 ⓘ	7	1.0	\$277	\$281	\$297
	HLSL2470	6	1.0	\$218	\$222	\$238
	HLSL2070	5	1.0	\$201	\$205	\$221

NOTES: 7" O-Leg Support to be placed upon Low Credenza models to support worksurfaces. Ship 1/pack.

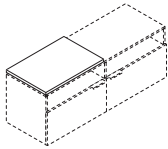

DESCRIPTION	MODEL	SHIP WEIGHT	CUBE	LIST PRICE BY FABRIC GRADE					
				1	2	3	4	5	6
Credenza Cushion 20"W x 36"D x 1"H for 72" Credenzas 20"W x 30"D x 1"H for 60" Credenzas	HLSL2036CH2	11	2.2	\$410	\$448	\$486	\$525	\$574	\$624
	HLSL2030CH2	9	1.9	\$380	\$416	\$452	\$488	\$534	\$581

NOTES: See pages 22-24 for available fabrics.
 ⓘ COM: .75
SPECIFYING EXAMPLE: HLSL2036CH2.APN23

NOTES:

- Worksurfaces with 7" O-legs, may be placed upon low credenzas to create layering.
- Chassis and drawer fronts woodgrains and solid laminates are specified separately (see SIF options on preceding page).
- Seat cushions are available for low credenzas and mobile pedestals (specify separately).
- Storage accessory model HL3DRWORG works with box doors.
- Layering shelf works with low credenzas to provide additional storage areas.
- File, lateral, and wide box drawers operate on ball-bearing suspension with full extension.
- Adjustable hex leveling glides allow floor-standing furniture to be easily leveled without lifting the unit; glides have 1/4" adjustable range.
- Ships with one handle per drawer on all units.

HOW TO SPECIFY

Select Model Number	Select Paint Color
See page 173	See page 173
H L S L 3 0 7 0 .	T 1

Laminate Low Footed Credenzas

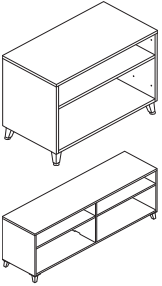
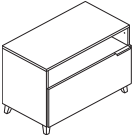
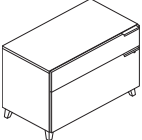
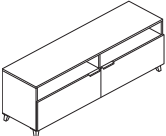
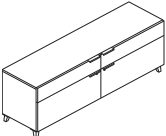
	DESCRIPTION	MODEL	SHIP WEIGHT	CUBE	L1 LIST	L2 UPCHARGES	
						CHASSIS	FRONTS
	Low Credenza, Open, Footed						
	30"W x 20"D x 24½"H	HLSL2030LD0F Ⓢ	67	9.8	\$945	\$25	N/A
	36"W x 20"D x 24½"H	HLSL2036LD0F	87	11.9	\$972	\$30	N/A
	60"W x 20"D x 24½"H	HLSL2060LD0F	132	19.9	\$1145	\$35	N/A
	72"W x 20"D x 24½"H	HLSL2072LD0F	172	23.7	\$1364	\$40	N/A
	Low Credenza, 1 File/Open, Footed						
	30"W x 20"D x 24½"H	HLSL2030LD1F	77	9.8	\$1044	\$25	\$15
	36"W x 20"D x 24½"H	HLSL2036LD1F	97	11.9	\$1074	\$30	\$15
	Low Credenza, 1 File/1 Box, Footed						
	30"W x 20"D x 24½"H	HLSL2030LD2F	82	9.8	\$1154	\$25	\$20
	36"W x 20"D x 24½"H	HLSL2036LD2F	102	11.9	\$1186	\$30	\$20
	Low Credenza, 2 File/Open, Footed						
	60"W x 20"D x 24½"H	HLSL2060LD2F	162	19.9	\$1475	\$35	\$30
	72"W x 20"D x 24½"H	HLSL2072LD2F	202	23.7	\$1608	\$40	\$30
	Low Credenza, 2 File/2 Box, Footed						
	60"W x 20"D x 24½"H	HLSL2060LD4F	192	19.9	\$1570	\$35	\$40
	72"W x 20"D x 24½"H	HLSL2072LD4F	232	23.7	\$1715	\$40	\$40

NOTES:

- Worksurfaces with 4" stanchions may be placed upon low credenzas to create layering.
- Chassis and drawer fronts woodgrains and solid laminates are specified separately (see SIF options below).
- File drawers accept hanging folders in letter size.
- Multiple handle locations possible per customer preference.
- Seat cushions are available for low credenzas (specify separately).
- Storage accessory model HLSLDRWORG works with box drawers.
- Layering shelf works with low credenzas to provide additional storage areas.
- File, lateral, and wide box drawers operate on ball-bearing suspension with full extension.
- Adjustable hex leveling glides allow floor-standing furniture to be easily leveled without lifting the unit; glides have 1/4" adjustable range.
- Ships with one handle per drawer on all units.

ⓘ Locking units equipped with HON "One Key" interchangeable core removable locks. Keyed alike core must be ordered separately.

ⓘ 7" O-legs cannot be used as a support on footed credenzas.

HOW TO SPECIFY

Select Model Number	Select Chassis Laminate	Select Drawer Front Laminate	Select Pull Color	Select Foot Color
	See page 173	See page 173	See page 173 Not specified for Open Credenza models	See page 173
HLSL2030LD0F	C	C	T1	T1

Laminate Low Footed Credenzas

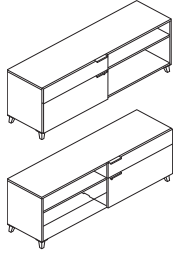

DESCRIPTION

Low Credenza, Box/File, Open, Footed

60"W x 20"D x 24½"H — Left Hand Drawers
72"W x 20"D x 24½"H — Left Hand Drawers

60"W x 20"D x 24½"H — Right Hand Drawers
72"W x 20"D x 24½"H — Right Hand Drawers

MODEL

SHIP
WEIGHT

CUBE

L1
LISTL2 UPCHARGES
CHASSIS FRONTS

HLSL2060LL2F

162

19.9

\$1356

\$35

\$20

HLSL2072LL2F

202

23.7

\$1593

\$40

\$20

HLSL2060LR2F

162

19.9

\$1356

\$40

\$20

HLSL2072LR2F

202

23.7

\$1593

\$40

\$20

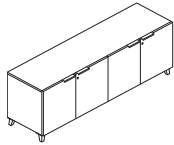
**Low Credenza, 4 Storage Doors, Footed**

60"W x 20"D x 24½"H
72"W x 20"D x 24½"H

HLSL2060S4F

162

19.9

\$1472

\$35

\$40

HLSL2072S4F

192

23.7

\$1702

\$40

\$40

NOTES:

- Worksurfaces with 4" stanchions may be placed upon low credenzas to create layering.
- Chassis and drawer fronts woodgrains and solid laminates are specified separately (see SIF options below).
- File drawers accept hanging folders in letter size.
- Multiple handle locations possible per customer preference.
- Seat cushions are available for low credenzas and mobile pedestals (specify separately).
- Storage accessory model HLSLDRWORG works with box doors.
- Layering shelf works with low credenzas to provide additional storage areas.
- File, lateral, and wide box drawers operate on ball-bearing suspension with full extension.
- Adjustable hex leveling glides allow floor-standing furniture to be easily leveled without lifting the unit; glides have 1/4" adjustable range.
- Ships with one handle per drawer on all units.

⚠ Locking units equipped with HON "One Key" interchangeable core removable locks. Keyed alike core must be ordered separately.

⚠ 7" O-legs cannot be used as a support on footed credenzas.

HOW TO SPECIFY

Select
Model Number

HLSL2060LL2F.

Select
Chassis Laminate

See page 173

C.

Select
Drawer Front Laminate

See page 173

C.

Select
Pull Color

See page 173

Not specified for Open
Credenza models



T1.

Select
Foot Color

See page 173

T1

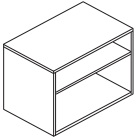

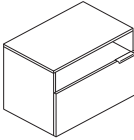
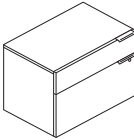
	DESCRIPTION	MODEL	SHIP WEIGHT	CUBE	L1 LIST	L2 UPCHARGES	
						CHASSIS	FRONTS
	Low Credenza — Open						
	30"W x 20"D x 21½"H 36"W x 20"D x 21½"H	HLSL2030LDO  HLSL2036LDO	65 85	9.8 12.0	\$889 \$916	\$25 \$30	N/A N/A
	Low Credenza — Open Top, File Drawer						
	30"W x 20"D x 21½"H 36"W x 20"D x 21½"H NOTES: Unit is non-locking.	HLSL2030LD1 HLSL2036LD1	75 95	9.8 12.0	\$988 \$1018	\$25 \$30	\$15 \$15
	Low Credenza — 1 File Drawer, 1 Box Drawer						
	30"W x 20"D x 21½"H 36"W x 20"D x 21½"H NOTES: Unit is locking.	HLSL2030LD2 HLSL2036LD2	80 100	9.8 12.0	\$1098 \$1130	\$25 \$30	\$20 \$20

NOTES:

- Worksurfaces with 7" O-legs, may be placed upon low credenzas to create layering.
- File drawers accept hanging folders in letter size.
- Multiple handle locations possible per customer preference.
- Post legs on Shared Overhead are compatible to attach to low credenzas.
- Storage accessory model HSLDRWORG works with box doors.
- File, lateral, and wide box drawers operate on ball-bearing suspension with full extension.
- Utilize in small footprint applications.
- Adjustable hex leveling glides allow floor-standing furniture to be easily leveled without lifting the unit; glides have 1/4" adjustable range.
- Ships with one handle per drawer on all units.

 Locking units equipped with HON "One Key" interchangeable core removable locks. Keyed alike core must be ordered separately.

HOW TO SPECIFY

Select Model Number HLSL2030LDO	Select Chassis Laminate See page 173 N	Select Drawer Front Laminate See page 173 Not specified for Open Credenza models HLSL2030LDO, HLSL2036LDO N	Select Pull Color See page 173 Not specified for Open Credenza models HLSL2030LDO, HLSL2036LDO T4
---	---	---	---

VOI® Laminate Mobile Storage

GSA SIN 33721

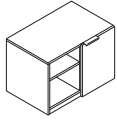

Icon Legend on page 19

**DESCRIPTION**

Mobile Credenza
30"W x 20"D x 21½"H

NOTES: Unit is non-locking.

MODEL

HLSL2030MCO

SHIP WEIGHT

80

CUBE

9.8

L1 LIST

\$1427

L2 UPCHARGES

CHASSIS	FRONTS
\$25	\$10

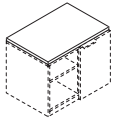
**DESCRIPTION**

Credenza Cushion
20"W x 30"D x 1"H for 60" Credenzas

NOTES: See pages 22-24 for available fabrics.

COM: .75

SPECIFYING EXAMPLE: HLSL2030CH2.APN23

MODEL

HLSL2030CH2

SHIP WEIGHT

9

CUBE

1.9

LIST PRICE BY FABRIC GRADE

1	2	3	4	5	6
\$380	\$416	\$452	\$488	\$534	\$581

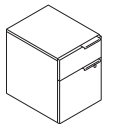
**DESCRIPTION**

Mobile Pedestal
15¾"W x 20⅞"D x 21⅞"H

NOTES: Unit is locking.

MODEL

HLSL2016MP2

SHIP WEIGHT

65

CUBE

5.7

L1 LIST

\$813

L2 UPCHARGES

CHASSIS	FRONTS
\$20	\$10

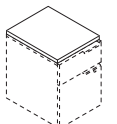
**DESCRIPTION**

Mobile Pedestal Cushion
15⅞"W x 20"D x 1"H for Pedestals

NOTES: See pages 22-24 for available fabrics.

SPECIFYING EXAMPLE: HLSL2016PH2.APN23

MODEL

HLSL2016PH2

SHIP WEIGHT

6

CUBE

1.1

LIST PRICE BY FABRIC GRADE

1	2	3	4	5	6
\$315	\$339	\$363	\$387	\$418	\$449

NOTES:

- Chassis and drawer fronts woodgrains and solid laminates are specified separately (see SIF options below).
- File drawers accept hanging folders in letter or legal size.
- Multiple handle locations possible per customer preference.
- Seat cushions are available for low credenzas, floor credenzas, and mobile pedestals (specify separately).
- Storage accessory model HSLDRWORG works with box doors.
- Standard box drawers operate on ball-bearing suspension with 70% extension. File drawers operate on ball-bearing suspension with 70% extension.
- Ships with one handle per drawer on all units.

! Locking units equipped with HON "One Key" interchangeable core removable locks. Keyed alike core must be ordered separately.

HOW TO SPECIFY**Select Model Number**

HLSL2030MCO

Select Chassis Laminate

See page 173

N

Select Drawer Front Laminate

See page 173

N

Select Pull Color

See page 173

T4

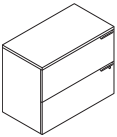
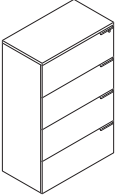
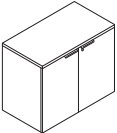
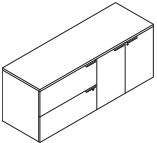
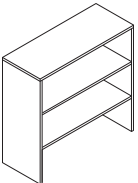

	DESCRIPTION	MODEL	SHIP WEIGHT	CUBE	L1 LIST	L2 UPCHARGES	
						CHASSIS	FRONTS
	2-Drawer Lateral Files 36"W x 24"D x 29½"H 36"W x 20"D x 29½"H	HLSL2436L2	305	29.8	\$1310	\$35	\$20
		HLSL2036L2	170	15.7	\$1175	\$30	\$20
	4-Drawer Lateral Files 36"W x 24"D x 57"H 36"W x 20"D x 57"H	HLSL2436L4	366	35.9	\$1863	\$45	\$30
		HLSL2036L4	204	18.3	\$1750	\$40	\$30
	Storage Cabinet 36"W x 24"D x 29½"H 36"W x 20"D x 29½"H	HLSL2436SC	150	18.3	\$992	\$35	\$20
		HLSL2036SC	147	15.7	\$932	\$30	\$20
	Lateral/Storage Cabinet Credenza 72"W x 24"D x 29½"H	HLSL2472LC	300	35.6	\$2641	\$45	\$30
	Bookcase Hutch (no doors) 36"W x 14"D x 35"H NOTES: Bookcase Hutch model works with Storage Cabinet and Lateral File models shown above. ! Specify: Chassis laminate only. ! Top two shelves have 12" spacing to allow for binder storage and bottom shelf has 8¼" spacing.	HLSL1436BH	125	3.7	\$716	\$20	N/A

NOTES:

- Ships with one handle per drawer on all units.
 - All models shown below are locking.
 - Chassis and drawer fronts woodgrains and solid laminates are specified separately (see SIF options below).
 - File drawers accept hanging folders in letter or legal size.
 - Multiple handle locations possible per customer preference.
 - Adjustable hex leveling glides allow floor-standing furniture to be easily leveled without lifting the unit; glides have 1¼" adjustable range.
- ! Locking units equipped with HON "One Key" interchangeable core removable locks. Keyed alike core must be ordered separately.

HOW TO SPECIFY

Select Model Number	Select Chassis Laminate	Select Drawer Front Laminate	Select Pull Color
	See page 173	See page 173 Not specified for model HLSL1436BH	See page 173 Not specified for Bookcase Hutch model HLSL1436BH
HLSL2036L2	N	N	T4

VOI® Laminate Storage Cubes

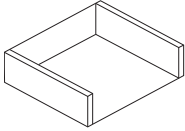
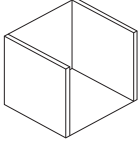
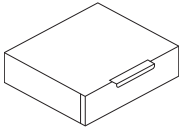
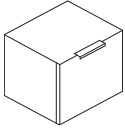

	DESCRIPTION	MODEL	SHIP WEIGHT	CUBE	L1 LIST	L2/P2 UPCHARGES		
						CHASSIS	DOOR FRONT	PAINT
	Short Open Cube 15"W x 13"D x 4"H	HLSL154LSO	9	1.4	\$147	\$10	N/A	\$8
	Tall Open Cube 15"W x 13"D x 12"H	HLSL1512LSO	16	2.9	\$176	\$10	N/A	\$8
	Drawer Cube 15"W x 13"D x 4"H	HLSL154LSD	19	1.4	\$221	\$10	\$5	\$8
	Cabinet Cube 15"W x 13"D x 12"H – Right Handed	HLSL1512LSCR	24	2.9	\$221	\$10	\$5	\$8
	15"W x 13"D x 12"H – Left Handed	HLSL1512LSCL	24	2.9	\$221	\$10	\$5	\$8

NOTES:

- 4"H and 12"H cubes attach to credenzas, worksurfaces, or wall mounted shelves.
- Configurable components are assembled using double-sided tape.
- Three 4"H cubes can be stacked to the height of one 12"H cube.

⚠ Do not leave a gap wider than 15" between cubes while assembled with a shelf.

⚠ Do not stack cube and shelf configurations higher than 30".

HOW TO SPECIFY

<p>Select Model Number</p> <p>HL S L 1 5 4 L S D .</p>	<p>Select Chassis Laminate</p> <p>See page 173</p> <p>C .</p>	<p>Select Front Laminate</p> <p>See page 173</p> <p>Not specified on HL S L 1 5 4 L S O and HL S L 1 5 1 2 L S O</p> <p>C .</p>	<p>Select Paint Color</p> <p>See page 173</p> <p>P3 upcharge (+ \$20)</p> <p>T 1 .</p>	<p>Select Pull Color</p> <p>See page 173</p> <p>Not specified on HL S L 1 5 4 L S O and HL S L 1 5 1 2 L S O</p> <p>T 1</p>
---	--	--	---	--

	DESCRIPTION	MODEL	SHIP WEIGHT	CUBE	L1	L2
					LIST PRICE	UPCHARGE
	Shelves 30"W x 13"D	HLSLR1330	10	1.3	\$191	\$10
	36"W x 13"D	HLSLR1336	12	1.5	\$214	\$10
	45"W x 13"D	HLSLR1345	15	1.9	\$232	\$10

NOTES:

- Use shelves in between cubes to create another layering element, if desired.

HOW TO SPECIFY

<p>Select Model Number</p> <p>HL S L R 1 3 3 0 .</p>	<p>Select Laminate</p> <p>See page 173</p> <p>C</p>
---	--

Laminate Storage Cube Bundles

QTY	DESCRIPTION	MODEL	LIST PRICE	PRICE EXTENSION
2	Cube Bundle A Short Open Cube 15"W x 13"D x 4"H	HLSL154LSO	\$147	\$294
HLSL15-SOO			TOTAL:	\$294

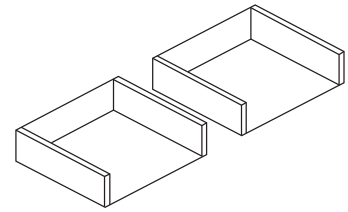

HLSL15-SOO

QTY	DESCRIPTION	MODEL	LIST PRICE	PRICE EXTENSION
3	Cube Bundle B Short Open Cube 15"W x 13"D x 4"H	HLSL154LSO	\$147	\$441
1	Tall Open Cube 15"W x 13"D x 12"H	HLSL1512LSO	\$176	\$176
HLSL15-SOOOLO			TOTAL:	\$617

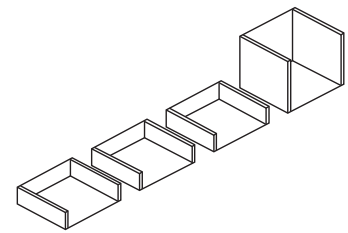

HLSL15-SOOOLO

QTY	DESCRIPTION	MODEL	LIST PRICE	PRICE EXTENSION
1	Cube Bundle C Short Open Cube 15"W x 13"D x 4"H	HLSL154LSO	\$147	\$147
1	Tall Open Cube 15"W x 13"D x 12"H	HLSL1512LSO	\$176	\$176
1	Drawer Cube 15"W x 13"D x 4"H	HLSL154LSD	\$221	\$221
1	Cabinet Cube, Right Handed 15"W x 13"D x 12"H	HLSL1512LSCR	\$221	\$221
HLSL15-SODLOC			TOTAL:	\$765

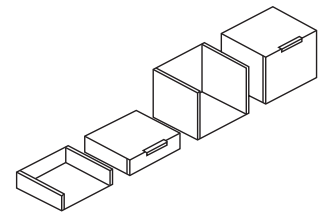

HLSL15-SODLOC

QTY	DESCRIPTION	MODEL	LIST PRICE	PRICE EXTENSION
2	Cube Bundle D Drawer Cube 15"W x 13"D x 4"H	HLSL154LSD	\$221	\$442
2	Cabinet Cube, Right Handed 15"W x 13"D x 12"H	HLSL1512LSCR	\$221	\$442
HLSL15-SDDLCC			TOTAL:	\$884

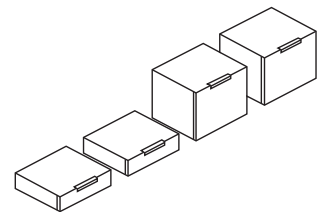

HLSL15-SDDLCC

QTY	DESCRIPTION	MODEL	LIST PRICE	PRICE EXTENSION
2	Cube Bundle E Drawer Cube 15"W x 13"D x 4"H	HLSL154LSD	\$221	\$442
2	Short Open Cube 15"W x 13"D x 4"H	HLSL154LSO	\$147	\$294
1	Tall Open Cube 15"W x 13"D x 12"H	HLSL1512LSO	\$176	\$176
1	Cabinet Cube, Right Handed 15"W x 13"D x 12"H	HLSL1512LSCR	\$221	\$221
HLSL15-SOODDLOC			TOTAL:	\$1,133

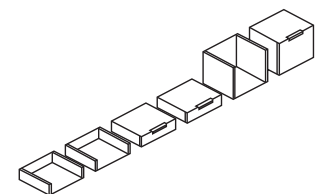

HLSL15-SOODDLOC

VOI® Laminate Storage Towers

GSA SIN 33721



Icon Legend on page 19

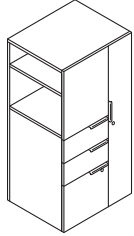

DESCRIPTION	MODEL	SHIP WEIGHT	CUBE	L1 LIST	L2 UPCHARGES	
					CHASSIS	FRONTS
24"W x 20"D Storage Tower — Right Hand Drawers, Left Hand Door						
24"W x 20"D x 50"H, Left	HLSLW045L	167	17.4	\$1967	\$50	\$35
24"W x 20"D x 65"H, Left	HLSLW046L	200	22.5	\$2231	\$55	\$35
24"W x 20"D Storage Tower — Left Hand Drawers, Right Hand Door						
24"W x 20"D x 50"H, Right	HLSLW045R	167	17.4	\$1967	\$50	\$35
24"W x 20"D x 65"H, Right	HLSLW046R	200	22.5	\$2231	\$55	\$35

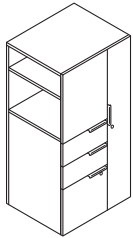

24"W x 24"D Storage Tower — Right Hand Drawers, Left Hand Door						
24"W x 24"D x 50"H, Left	HLSLW445L	200	20.7	\$2131	\$55	\$35
24"W x 24"D x 65"H, Left	HLSLW446L	240	27.8	\$2349	\$60	\$35
24"W x 24"D Storage Tower — Left Hand Drawers, Right Hand Door						
24"W x 24"D x 50"H, Right	HLSLW445R	200	20.7	\$2131	\$55	\$35
24"W x 24"D x 65"H, Right	HLSLW446R	240	27.8	\$2349	\$60	\$35

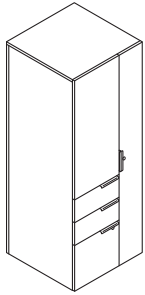

24"W x 24"D Personal Storage Tower						
24"W x 24"D x 65"H, Left	HLSLW446LP	250	27.8	\$2660	\$60	\$35
24"W x 24"D x 65"H, Right	HLSLW446RP	250	27.8	\$2660	\$60	\$35



DESCRIPTION	MODEL	SHIP WEIGHT	CUBE	LIST PRICE BY PAINT GRADE		
				P1	P2	P3
Worksurface to Tower Bracket Kit						
Bracket to attach storage towers or pedestal to worksurfaces.	HSTB2W1	4	0.6	\$79	\$92	\$94
NOTES: Can be used in place of end panel or O-leg to support worksurfaces.						
! Bracket cannot be used as a support when placing Stack-on Storage on worksurface over bracket. Must use two full-sized supports when using Stack-on Storage.						

NOTES:

- Use the worksurface to tower bracket kit to attach worksurfaces to Storage Towers models shown above.
- Chassis and drawer fronts woodgrains and solid laminates are specified separately (see SIF options below).
- File drawers accept hanging folders in letter or legal size.
- Wardrobe, middle box drawer and file drawer are locking.
- Standard box drawers operate on ball-bearing suspension with full extension. File, lateral, and wide box drawers operate on ball-bearing suspension with full extension.
- Ships with one handle per drawer on all units.
- Adjustable hex leveling glides allow floor-standing furniture to be easily leveled without lifting the unit; glides have 1/4" adjustable range.
- Wardrobe/storage cabinet includes coat rod.
- Wardrobes contain easy access side storage shelves.

! Locking units equipped with HON "One Key" interchangeable core removable locks. Keyed alike core must be ordered separately.

HOW TO SPECIFY

Select Model Number	Select Chassis Laminate	Select Drawer Front Laminate	Select Pull Color
See page 173	See page 173	See page 173	See page 173
HLSLW045L	N	N	T4

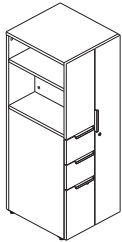
**DESCRIPTION****MODEL****SHIP WEIGHT****CUBE****L1 LIST****L2 UPCHARGES**
CHASSIS FRONTS**18"W x 20"D Storage Towers — Right Hand Drawers, Left Hand Door**

18"W x 20"D x 50"H, Left

HLSLW085L

139

13.4

\$1771**\$45****\$35**

18"W x 20"D x 65"H, Left

HLSLW086L

167

17.3

\$2012**\$50****\$35****18"W x 20"D Storage Towers — Left Hand Drawers, Right Hand Door**

18"W x 20"D x 50"H, Right

HLSLW085R

139

13.4

\$1771**\$45****\$35**

18"W x 20"D x 65"H, Right

HLSLW086R

167

17.3

\$2012**\$50****\$35****18"W x 24"D Storage Towers — Right Hand Drawers, Left Hand Door**

18"W x 24"D x 50"H, Left

HLSLW485L

167

15.8

\$2015**\$50****\$35**

18"W x 24"D x 65"H, Left

HLSLW486L

200

21.5

\$2234**\$55****\$35****18"W x 24"D Storage Towers — Left Hand Drawers, Right Hand Door**

18"W x 24"D x 50"H, Right

HLSLW485R

167

15.8

\$2015**\$50****\$35**

18"W x 24"D x 65"H, Right

HLSLW486R

200

21.5

\$2234**\$55****\$35****NOTES:**

- Ships with one handle per drawer on all units.
- Chassis and drawer fronts woodgrains and solid laminates are specified separately (see SIF options below).
- File drawers accept hanging folders in letter or legal size.
- Standard box drawers operate on ball-bearing suspension with full extension. File and box drawers operate on ball-bearing suspension with full extension.
- Adjustable hex leveling glides allow floor-standing furniture to be easily leveled without lifting the unit; glides have 1/4" adjustable range.
- Wardrobe/storage cabinet includes coat rod.
- Wardrobes contain easy access side storage shelves.
- Wardrobe, middle box drawer and file drawer are locking.
- ! Locking units equipped with HON "One Key" interchangeable core removable locks. Keyed alike core must be ordered separately.
- ! Worksurface-to-tower bracket cannot be used as a support when placing Stack-on Storage on worksurface over bracket. Must use two full-sized supports when using Stack-on Storage.

HOW TO SPECIFY

Select Model Number	Select Chassis Laminate	Select Door/Drawer Front Laminate	Select Pull Color
HL SLW085L	N	N	T4
See page 173	See page 173	See page 173	See page 173

VOI® Laminate Storage Towers

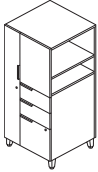
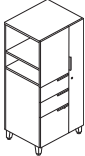
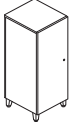
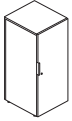
	DESCRIPTION	MODEL	SHIP WEIGHT	CUBE	L1 LIST	L2 UPCHARGES	
						CHASSIS	FRONTS
	Storage Towers, Right Hand Drawers, Left Hand Doors, Footed						
	20"W x 18"D x 54"H	HLSLW085LF	141	13.7	\$1827	\$45	\$35
	24"W x 18"D x 54"H	HLSLW485LF	169	16.2	\$2071	\$50	\$35
	20"W x 24"D x 54"H	HLSLW045LF	169	17.8	\$2023	\$50	\$35
	24"W x 24"D x 54"H	HLSLW445LF	202	21.1	\$2187	\$55	\$35
	Storage Towers, Left Hand Drawers, Right Hand Doors, Footed						
	20"W x 18"D x 54"H	HLSLW085RF	141	13.7	\$1827	\$45	\$35
	24"W x 18"D x 54"H	HLSLW485RF	169	16.2	\$2071	\$50	\$35
	20"W x 24"D x 54"H	HLSLW045RF	169	17.8	\$2023	\$50	\$35
	24"W x 24"D x 54"H	HLSLW445RF	202	21.1	\$2187	\$55	\$35
	Storage Towers, One Door, Footed						
	18"W x 20"D x 46"H — Left Hand Door	HLSLW084LF	105	11.3	\$1308	\$35	\$25
	18"W x 20"D x 46"H — Right Hand Door	HLSLW084RF	105	11.3	\$1308	\$35	\$25
	Storage Towers, One Door, Non-Footed						
	18"W x 20"D x 42"H — Left Hand Door	HLSLW084L	102	11.3	\$1252	\$35	\$25
	18"W x 20"D x 42"H — Right Hand Door	HLSLW084R	102	11.3	\$1252	\$35	\$25

NOTES:

- Use the worksurface to tower bracket kit to attach worksurfaces to Storage Towers models shown above.
- Chassis and drawer fronts woodgrains and solid laminates are specified separately (see SIF options below).
- File drawers accept hanging folders in letter or legal size.
- Wardrobe, middle box drawer and file drawer are locking.
- Standard box drawers operate on ball-bearing suspension with full extension. File, lateral, and wide box drawers operate on ball-bearing suspension with full extension.
- Ships with one handle per drawer on all units.
- Adjustable hex leveling glides allow floor-standing furniture to be easily leveled without lifting the unit; glides have 1/4" adjustable range.
- Wardrobe/storage cabinet includes coat rod.
- Wardrobes contain easy access side storage shelves.

! Locking units equipped with HON "One Key" interchangeable core removable locks. Keyed alike core must be ordered separately.

HOW TO SPECIFY

<p>Select Model Number</p> <p>HL SLW085LF</p>	<p>Select Chassis Laminate</p> <p>See page 173</p> <p>C</p>	<p>Select Drawer Front Laminate</p> <p>See page 173</p> <p>C</p>	<p>Select Pull Color</p> <p>See page 173</p> <p>T1</p>	<p>Select Foot Color</p> <p>See page 173</p> <p>T1</p>
---	---	--	--	--



DESCRIPTION	MODEL	SHIP WEIGHT	CUBE	L1 LIST	L2 UPCHARGES	
					CHASSIS	FRONTS
Box/File Pedestal, Footed 16"W x 20"D x 28½"H	HLSL2016FP2	65	5.8	\$869	\$20	\$10

NOTES:

- Ships with one handle per drawer on all units.
 - All models shown below are locking.
 - Chassis and drawer fronts woodgrains and solid laminates are specified separately (see SIF options below).
 - File drawers accept hanging folders in letter or legal size.
 - Multiple handle locations possible per customer preference.
 - Adjustable hex leveling glides allow floor-standing furniture to be easily leveled without lifting the unit; glides have 1/4" adjustable range.
- ! Locking units equipped with HON "One Key" interchangeable core removable locks. Keyed alike core must be ordered separately.

HOW TO SPECIFY

Select Model Number See page 173	Select Chassis Laminate See page 173	Select Drawer Front Laminate See page 173	Select Pull Color See page 173	Select Foot Color See page 173
H L S L 2 0 1 6 F P 2 .	C .	C .	T 1 .	T 1

VOI® Laminate Bookcases

GSA SIN 33721



Icon Legend on page 19

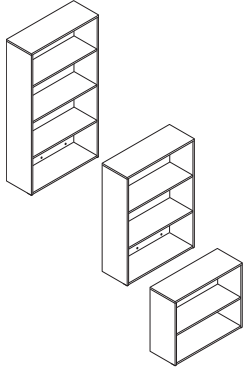

DESCRIPTION	MODEL	SHIP WEIGHT	CUBE	LIST PRICE BY LAMINATE GRADE	
				L1	L2
Bookcase 36"W x 13"D x 29½"H, 2-Shelf	HLSL1336B2	90	10.7	\$569	\$584
36"W x 13"D x 50"H, 3-Shelf	HLSL1336B3	122	17.3	\$734	\$754
36"W x 13"D x 65"H, 4-Shelf	HLSL1336B4	156	22.2	\$863	\$888





NOTES: Bookcases available in 2, 3 and 4 shelf models. Adjustable glides allow bookcases to be easily leveled. Glides have 1/4" of adjustability.

HOW TO SPECIFY

<p>Select Model Number</p> <p>H L S L 1 3 3 6 B 2 . N</p>	<p>Select Laminate</p> <p>See page 173</p>
--	---

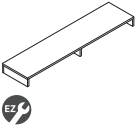

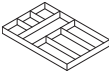
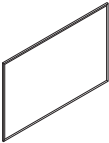
Icon Legend on page 19

	DESCRIPTION	MODEL	SHIP WEIGHT	CUBE	L1 LIST PRICE	L2 UPCHARGE	
	Layering Shelf 72"W x 14½"D x 5½"H 60"W x 14½"D x 5½"H	HLSL1472LS HLSL1460LS	50 39	4.6 1.3	\$444 \$372	\$10 \$10	
	NOTES: Layering shelf works with lower credenzas to provide additional storage areas. For additional information see the Workplace Tools section in the 2021 Shared Spaces Pricer. ! Layering Shelves cannot be stacked. ! Cannot add a hutch on top of a layering shelf.						
	Storage Cube 12"W x 12"D SPECIFYING EXAMPLE: HLSL1212.P8S	HLSL1212	1.0	0.3		\$294	
	NOTES: For additional information see the Workplace Tools section in the 2021 Shared Spaces Pricer. SPECIFYING EXAMPLE: HLSLDRWORG.P8F						
	Drawer Organizer 12"W x 14½"D x 1½"H	HLSLDRWORG	1.0	0.5		\$156	
	NOTES: No specification required. For additional information see the Workplace Tools section in the 2021 Shared Spaces Pricer.						
	Markerboard 48"W x 31"H	HLSL4831MB	44.0	3.4		\$664	
	NOTES: No specification required. For additional information see the Workplace Tools section in the 2021 Shared Spaces Pricer.						
 <p>OPEN MARKET</p>	LED Task Lights 17" LED Light with Power Supply (Single) 31" LED Light with Power Supply (Single)	HLED17AS ☹️ HLED31AS ☹️	1.2 ☹️ 1.5 ☹️	0.05 0.09		\$420 \$564	
	17" LED Light with Power Supply for Daisy-chain (Starter) 31" LED Light with Power Supply for Daisy-chain (Starter)	HLED17A HLED31A	1.0 ☹️ 1.4 ☹️	0.05 0.09		\$461 \$619	
	17" LED Light with 8" Jumper Cord for Daisy-chain (Follower) 31" LED Light with 8" Jumper Cord for Daisy-chain (Follower)	HLED17AUO ☹️ HLED31AUO ☹️	1.0 ☹️ 1.0 ☹️	0.03 0.05		\$377 \$503	
	Undercabinet Occupancy Sensor with 1" End to End Connector	HLEDOSA ☹️	0.2 ☹️	0.01		\$89	
	NOTES: To use the daisy chain application, must start with model HLED17A or HLED31A. No finish specification required. Attaches magnetically to underside of overhead storage, or attaches with provided screws or double-sided tape. Occupancy sensor attaches to a single or starter LED light and will automatically turn the light off after no motion is detected for 30 minutes. Just like all the LED light models, the occupancy sensor features a soft-touch on/off switch. LED task lights have a lifetime of 50,000 hours and have a dimmer feature that allows the user to adjust the amount of light output.						

HOW TO SPECIFY

Select Model Number HLSL1472LS	Select Laminate See page 173 N
-----------------------------------	--------------------------------------

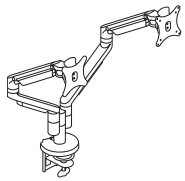
**DESCRIPTION****Dual Dynamic Monitor Arm**

- 150° of rotation at base with optional 360° rotation.
- Arms extend 22" and retract up to 3".
- Monitor mount rotates 180° and tilts +/-30°.
- Monitor can be rotated from landscape to portrait position.

! Arms hold monitors from 6.2-18 lbs. Optional counterweight HPACW available to support monitors as low as 5 lbs. (see the Workplace Tools section in the 2021 Shared Spaces Pricer).

MODEL**HMASD****SHIP WEIGHT**

17.0

CUBE

1.1

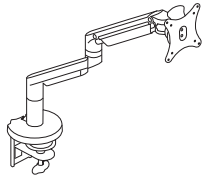
LIST PRICE**\$900****Single Dynamic Monitor Arm**

- 180° of rotation at base with optional 360° rotation.
- Arms extend 22" and retract up to 3".
- Monitor mount rotates 180° and tilts +/-30°.
- Monitor can be rotated from landscape to portrait position.

! Arms hold monitors from 6.2-18 lbs. Optional counterweight HPACW available to support monitors as low as 5 lbs. (see the Workplace Tools section in the 2021 Shared Spaces Pricer).

HMASTS

11.5

0.8

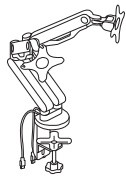
\$468**Dual Monitor Arm with 2 USB Ports**

NOTES: Easy adjustment. Height adjusts to 17" tall. Monitor tilt and swivel capability. Enclosed cable management. Grommet or desktop mounting. Clean appearance. In some applications the Monitor Arms may extend 12 or more inches into the worksurface. For additional information see the Workplace Tools section in the 2021 Shared Spaces Pricer. **HON 5-Year Limited Warranty.**

! No specification needed.

HBDMAUSB

41.9

2.6

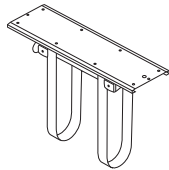
\$383**360° Swivel CPU Holder with Adjustable Straps**

- Supports CPUs 3¾" wide up to 64" perimeter and holds up to 75 lbs.
- 360° rotation.
- Ships complete and includes necessary mounting hardware and instruction sheet.

! Available in Black only, no specification needed.

HCPU1

7.0

0.2

\$243**SIN 33721****NOTES:**

- For additional information see the Workplace Tools section in the 2021 Shared Spaces Pricer.

Monitor Arms

- Arms fold back to post to allow more desktop room.
- Arms feature double extension, allowing 20"+ of back and forth movement.
- Cable management on both pole and arm assemblies.
- Counterbalance adjustment provides stability for monitors up to 17.6 lbs per arm.
- Made of high quality aluminum alloy material.
- See the Workplace Tools section in the 2021 Shared Spaces Pricer for additional monitor arm models.

HOW TO SPECIFY**Select Model Number****Select Finish**

Specify for models HMASD and HMASTS only





SVR Silver
BLK Black

HMASD.

SVR

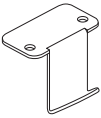

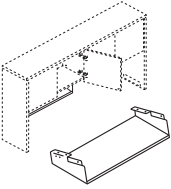
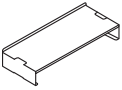
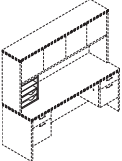
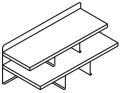
Icon Legend on page 19

	DESCRIPTION	MODEL	SHIP WEIGHT	CUBE	LIST PRICE
 <p>Back Pack Hook (10 per carton) 12"W x 14½"D x 1½"H</p> <p>NOTES: Assembly: attaches to bottom of desk with (2) screws, included.</p> <p>! Available in Platinum Metallic finish only, no specification needed.</p> <p>OPEN MARKET</p> 		HCLA65	10 	0.1	\$95
 <p>Hanging Paper Shelf 28½"W x 11⅞"D x 4⅜"H</p> <p>NOTES: Attaches quickly and easily (screws included). Maximizes worksurface space; de-clutters desktop while placing priority communications and active project folders within easy reach. Angled design allows contents to be distinguished at a glance. Mixed material styling features strong painted metal frame with a frosted shelf.</p> <p>Attaches quickly and easily to laminate stack-on and wall mount storage models (except the 36"W Voi® overhead hutch with O-legs or panel mount brackets). Not for use with 38000 Series™ and Systems.</p> <p>For additional information see the Workplace Tools section in the 2021 Shared Spaces Pricer.</p> <p>Specify: Model.Paint</p> <p>SPECIFYING EXAMPLE: HHPST1</p>		HHPST1	7	2.9	\$198
 <p>Desktop Paper Shelf 28½"W x 11⅞"D x 5"H</p> <p>NOTES: Desktop Paper Shelf and Storage Terrace include protective, non-slip pads on the base. Paper Shelf can stack two-high. Organizer shelf provides a place and space for work-in-process and piling to keep worksurfaces neat and tidy. Convenient, scalable design with interlocking side supports allow two units to be stacked and integrated. Durable painted metal frame with a frosted shelf; mixed material styling matches hanging paper shelf.</p> <p>Can also be used inside select overhead storage, including the following stack-on with clearance and hinged door models: 10500 and Valido 36", 42", 66", 72", 78"W and 10700 68⅝"W.</p> <p>For additional information see the Workplace Tools section in the 2021 Shared Spaces Pricer.</p> <p>Specify: Model.Paint</p> <p>SPECIFYING EXAMPLE: HDPS1.T1</p>		HDPS1	7	2.9	\$198
 <p>Vertical Paper Manager 14⅞"W x 10⅞"D x 19⅞"H</p> <p>NOTES: Keeps papers, files, and books neatly organized and within easy reach from a seated position. Designed for desk, credenza, and return tops. Fits under stack-on storage models. Two pullout drawers and three fixed shelves. Not available in pattern laminate colors. Ships fully assembled. For additional information see the Workplace Tools section in the 2021 Shared Spaces Pricer.</p> <p>! When used in conjunction with wall mounted storage cabinets, the top of the wall mounted storage cabinets must be positioned a minimum of 68⅜" above the floor.</p> <p>SPECIFYING EXAMPLE: HLVPM1.N</p> <p><i>Not available in two-tone laminates</i></p>		HLVPM1	27	2.8	\$327
 <p>Desktop Storage Terrace 26½"W x 12½"D x 10½"H</p> <p>NOTES: Keeps work-in-process, priority files, loose pages, and mail neatly organized and in view. Mixed material design comprised of sturdy laminate shelves with metal back and support panels. Not available in two-tone laminate combination or pattern laminate colors. Choose from Platinum Metallic (T1), Black (P), and Charcoal (S) for the metal components.</p> <p>Sized to fit in stack-on and wall mounted storage cabinets in 10500, 10700, Valido, 94000, and 38000 Series. Fits in Voi stack-on and overhead cabinets except for 48"W or smaller sliding door models. For additional information see the Workplace Tools section in the 2021 Shared Spaces Pricer.</p> <p>Specify: Model.Laminate.Paint</p> <p>SPECIFYING EXAMPLE: HLDST1.N.T1</p> <p><i>Not available in two-tone laminate</i></p> 		HLDST1	24	1.1	\$306

HOW TO SPECIFY

Select
Model Number

H C L A 6 5

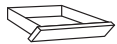

Refer to page 106 for Center Drawer compatibility information

SIN 33721



DESCRIPTION

Angled Wood Center Drawer

26" x 15³/₈"
22" x 15³/₈"

MODEL

H1526

H1522

SHIP WEIGHT

12

11

CUBE

1.2

1.1

LIST PRICE

\$198

\$184

NOTES: Specify laminate for drawer. Ideal for pens, pencils and other miscellaneous storage. Feature ball-bearing slide suspension. For additional information see the Workplace Tools section in the 2021 Shared Spaces Pricer.

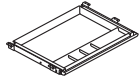

OPEN MARKET

Polymer Center Drawer

- Color: Black.
- Material: ABS.
- Minimum clearance for mounting: 23"W x 16¹/₄"D x 2"H.
- Retracts on 16" ball-bearing slides.
- Can be used on worksurfaces with Coordinate™ Height Adjustable Bases as long as it is attached with spacer model HKBS.
- Can store up to 25 lbs.

Black finish only, no specification needed.

HCD1

7

0.5

\$111

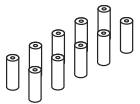

OPEN MARKET

Keyboard Spacer

- For use when attaching a keyboard tray to Coordinate™ and Voi® or Systems Worksurface with an external channel.
- The kit includes ten cylinder spacers and ten screws.
- Spacers are ³/₄"W x 2¹/₈"H.
- Specify one kit per keyboard tray.

NOTES: For additional information see the Workplace Tools section in the 2021 Shared Spaces Pricer.

HKBS

1

0.8

\$92

HOW TO SPECIFY

Select
Model Number

H C D 1



	DESCRIPTION	MODEL	SHIP WEIGHT	CUBE	LIST PRICE
	Articulating Desk Lamp Articulating Desk Lamp w/ Occupancy Sensor <ul style="list-style-type: none"> • Color: Matte Silver. • Full-range dimming from 10% to 100%. • Designed for 50,000 hours of life. • Occupancy sensor is built into the head of the lamp and will automatically shut the lamp off after 6 minutes of undetected movement. • Base swivel is 180 degrees. • Uses only 5 watts of energy. • Light comes with a silver 9' 4" power cord. • Base diameter is 7.5". • 3500K Color Temperature. • 80 Color Rendering Index. • TAA Compliant. 	HLED1 HLED10C	1.2 1.2	6.5 6.5	\$402 \$490
	Task Desk Lamp <ul style="list-style-type: none"> • Color: Brushed Nickel. • Full-range dimming from 10% to 100%. • Designed for 50,000 hours of life. • Lamp is 15.83" tall. • Desk lamp does not articulate at base. The pivoting head provides custom positioning, as it can be twisted 360 degrees. • Uses only 5 watts of energy. • Light comes with a silver 9' 4" power cord. • Base diameter is 6.7". • 3500K Color Temperature. • 80 Color Rendering Index. • TAA Compliant. 	HLED2	0.7	3.0	\$348

NOTES:

- For additional information see the Workplace Tools section in the 2021 Shared Spaces Pricer.

HOW TO SPECIFY
 Select
 Model Number

H L E D 1

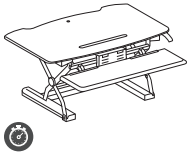
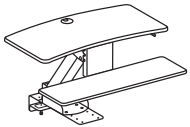
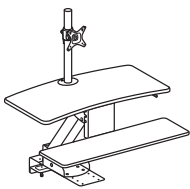
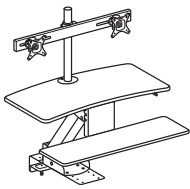
	DESCRIPTION	MODEL	SHIP WEIGHT	CUBE	LIST PRICE
	Coordinate™ Portable Desktop Riser 31"D x 5"-16½"H x 35"W NOTES: Available in Black (BLK) or White (WHT) finish. Desktop riser dimensions (without keyboard tray): 22"D x 5"-16½"H x 35"W. Keyboard tray dimensions: 9"D x 30"W. Max loading capacity is 33 lbs for the desktop riser surface and 4 lbs for the keyboard tray. Easily transition from seated to standing positions throughout the workday. Sits atop an existing desk to create sit-to-stand functionality by raising the computer. Includes keyboard tray and surface for computer monitors. HON 5-Year Limited Warranty. ⓘ Not intended for use on mobile workstations.	HBXRISER	54	4.1	\$619
	Coordinate™ Mounted Desktop Riser NOTES: Does not include a monitor arm and is suitable for laptops and/or monitors on their original stands. ⓘ No specification needed.	HS1100	60 ⓘ	3.2	\$664
	Coordinate™ Mounted Desktop Riser with Single Monitor Arm NOTES: Includes a monitor arm for a single monitor. ⓘ No specification needed.	HS1101	62 ⓘ	3.2	\$777
	Coordinate™ Mounted Desktop Riser with Dual Monitor Arm NOTES: Includes a monitor arm for dual monitors. ⓘ No specification needed.	HS1102	63 ⓘ	3.2	\$883

NOTES FOR HS1100, HS1101, HS1102:

- These products are designed to allow the user to transition from seating position to standing position throughout the workday.
- Gas-assist lever-operated mechanism with positive stop.
- Clamp mount compatible with worksurfaces depths of 20"-30". 20" is for systems only.
- Clamp requires 3.5" of clearance along back edge of worksurface.
- Black seamless worksurfaces.
- Silver powder coated metal components.
- Lowers below worksurface level on 24" and 30"D worksurfaces.
- All models contain a large primary worksurface and a smaller keyboard / mouse surface.
- Beveled edges for sleek appearance and comfort while typing.
- Monitor arms include height, width, and swivel adjustment.

- Not for use under overhead storage, with flush mounted modesty panels, or worksurfaces thinner than 1".

- ⓘ Not recommended for use on mobile (castered) worksurfaces.

MOUNTING AND COMPATIBILITY FOR HS1100, HS1101, HS1102:

- This product is intended to be installed on commercial-grade worksurfaces in good condition.
- Compatible with freestanding worksurfaces 24"-30"D or panel-supported worksurfaces 24"-30"D.
- Not for use on mobile worksurfaces.

Clamp Mount

Use when 3.5" minimum overhang is available

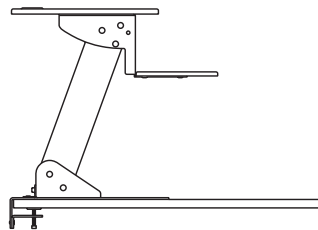
**Screw Mount**

Use when no overhang is available. Worksurface must be minimum 1" thick.

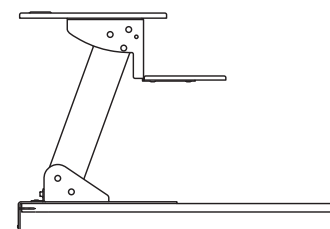

**HOW TO SPECIFY**Select
Model Number

HBXRISER.

Select
FinishBLK Black
WHT White

BLK

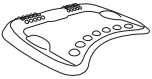
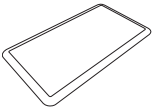
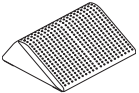

	DESCRIPTION	MODEL	SHIP WEIGHT	CUBE	LIST PRICE
	Rectangle Wobble Board — Anti-Fatigue Mat 18"D x 3"H x 22 ¹ / ₄ "W ⓘ Available in Black (T) finish ONLY. Recommended weight capacity not to exceed 250 pounds. HON 5-Year Limited Warranty. SPECIFYING EXAMPLE: HVL981.T	HVL981 ⓘ	10.0 Ⓔ	0.9	\$121
	Round Wobble Board — Anti-Fatigue Mat 18 ¹ / ₂ "D x 2 ¹ / ₈ "H x 18 ¹ / ₂ "W ⓘ Available in Black (T) finish ONLY. Recommended weight capacity not to exceed 250 pounds. HON 5-Year Limited Warranty. SPECIFYING EXAMPLE: HVL982.T	HVL982 ⓘ	5.8 Ⓔ	0.6	\$103
	Ergonomic Anti-Fatigue Mat 25"D x 2 ³ / ₄ "H x 29 ⁷ / ₈ "W ⓘ Available in Black ONLY. No specification needed. SPECIFYING EXAMPLE: HBEAFM1	HBEAFM1	7.0	1.4	\$219
	Rectangle Anti-Fatigue Mat 20"D x ³ / ₄ "H x 36"W ⓘ Available in Black ONLY. No specification needed. SPECIFYING EXAMPLE: HBAFM2036	HBAFM2036 ⓘ	5.4	0.4	\$100
	Footrest — Anti-Slip Cover 13 ³ / ₄ "D x 5 ¹ / ₂ "H x 16"W ⓘ Available in Black (T) finish ONLY. Recommended weight capacity not to exceed 250 pounds. HON 5-Year Limited Warranty. SPECIFYING EXAMPLE: HVL991.T	HVL991	7.0 Ⓔ	0.9	\$82

NOTES:

ⓘ Discontinued 1/1/21.

HOW TO SPECIFY

Select Model Number	Select Finish
H V L 9 8 1 .	T Black
	T

VOI® Softwire Electrical Components

GSA SIN 33721T EXCEPT AS NOTED

ABI

Icon Legend on page 19

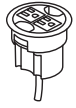
**DESCRIPTION****Power Hub, 3" Grommet Mount, 6' Cord**

- Fits in 3" round grommet holes
- Field installed with Plug-and-play ease
- Two grounded AC power outlets
- Includes 6' cord with three-prong plug

NOTES: For additional information see the Workplace Tools section in the 2021 Shared Spaces Pricer.

! Available in Black only. *Specify X when ordering. Example: HGRMTAC.X.***MODEL****HGRMTAC****SHIP WEIGHT**

1.3

CUBE

0.2

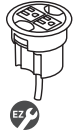
LIST PRICE**\$116****3" Round Power Grommet - 2 Outlets, 10' Cord**

- Includes 10' cord with three-prong plug.
- Fits in 3" round grommet holes on the following product lines: Coordinate, Huddle, Motivate, all laminate and veneer casegoods series, and Systems Worksurfaces.
- Two grounded AC power outlets.
- Field installed with Plug-and-play ease.

NOTES: Power Modules will also work with standing-height applications for 10500 Series™ and Voi® desks. Optional Memory Control allows preset worksurface heights for consistency. Ships separately. Dynamic load capacity when worksurface is moving is 300 lbs.

! Available in black finish only, no specification needed.

HGRMTAC2

1.5

0.2

\$148**Power/USB Hub, 3" Grommet Mount**

- One grounded AC power outlet with 2 USB ports.
- Two cord pass-through holes in cap.
- Includes 6' cord with three-prong plug.
- Field installed; easy plug-and-play.
- UL Listed.

NOTES: For additional information see the Workplace Tools section in the 2021 Shared Spaces Pricer.

! Available in black only (*no color designation so use .X - Specify: HGRMTUSB2.X*).**HGRMTUSB2**

1.3

0.2

\$226**Data Grommet**

Blank grommet kit that includes adapters for a variety of manufacturers jacks and couplers.

- Fits in existing 3" round grommet housing

NOTES: For additional information see the Workplace Tools section in the 2021 Shared Spaces Pricer.

! Available in Black only. *Specify P when ordering. Example: HGRMTDATA.P.***HGRMTDATA**

0.2

0.2

\$20

SIN 33721

HOW TO SPECIFYSelect
Model Number

H G R M T A C



Icon Legend on page 19



OPEN MARKET

DESCRIPTION

MODEL

SHIP WEIGHT

CUBE

LIST PRICE

O-Leg Cord Clips

Clips for 28½" Worksurface O-Legs — 8-Pack
Clips for Stack-on Storage, Hutch and Layering O-Legs — 4-Pack

HWMCLIPLG
HWMCLIPSM

0.8 **Ⓔ**
0.5 **Ⓔ**

0.1
0.1

\$99
\$65

NOTES: Wire clips work with 7" Low Credenza O-leg and 29"H Support O-leg. Wire clips also work with the 50" and 65" Hutch O-legs. For additional information see the Workplace Tools section in the 2021 Shared Spaces Pricer.

⚠ Available in frosted plastic material only.

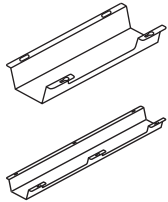

Cable Management Troughs

17"W — Single
17"W — 10-Pack
36"W — Single
36"W — 10-Pack

HCTROUGH17
HCTROUGH1710
HCTROUGH36
HCTROUGH3610

2.7 **Ⓔ**
14.0 **Ⓔ**
4.9 **Ⓔ**
30.0 **Ⓔ**

0.5
0.5
0.9
0.9

\$67
\$620
\$113
\$1045

- Cable management troughs ship flat packed.
- The troughs attach to underneath the worksurface with screws.
- The 17"W has one wire access cut out on the user side. The 36" has two wire access cut outs. These cut outs give users access to inside the trough without having to detach it from the worksurface.
- Color: Graphite.
- Material: Metal.
- TAA Compliant.

NOTES: For additional information see the Workplace Tools section in the 2021 Shared Spaces Pricer.



Power Pole — w/o Receptacles

10'5"

HH870070

14.0

0.5

\$433

⚠ Specify paint; not available in Putty (L), Platinum Metallic (T1), and Champagne Metallic (T4).

Specify paint color for HH870070, not available in Putty



Field Installable Grommet

HFLDGRMT3

0.1 **Ⓔ**

0.3

\$32

- Intended for use in tops and end panels to route/hide cords and in modesty panels to facilitate reaching wall electrical outlets.
- Grommet is field installable.
- Grommet shape is round.
- Includes grommet cap and sleeve.
- Grommet outside dimensions measure 3½" diameter and includes two cord access holes.
- Grommet sleeve measures 3" O.D. x 1" thick.
- Includes instructions to locate grommet position for desks, credenzas, returns and bridges.

NOTES: For additional information see the Workplace Tools section in the 2021 Shared Spaces Pricer.

⚠ Black Finish

⚠ Requires a 3" diameter hole saw and drill for installation (not included).

⚠ Not for use with credenzas, pedestals, laterals or towers.

HOW TO SPECIFY

Select Model Number

HWMCLIPLG

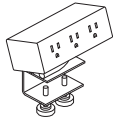

Model HPWRMOD3WC shown

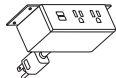

Model HPWRMOD2UWM shown

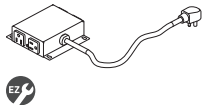
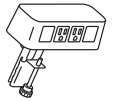

DESCRIPTION	MODEL	SHIP WEIGHT	CUBE	LIST PRICE
Power Modules				
3 Receptacles with Worksurface Clamp	HPWRMOD3WC	2.3	0.2	\$310
3 Receptacles with Under-Worksurface Mounting Bracket	HPWRMOD3UWM	2.3	0.2	\$310
2 Receptacles 2 USB with Worksurface Clamp	HPWRMOD2WC	2.3	0.2	\$496
2 Receptacles 2 USB with Under-Worksurface Mounting Bracket	HPWRMOD2UWM	2.3	0.2	\$496
<ul style="list-style-type: none"> • 6' power cord with standard three-prong plug. • Under-worksurface mounting bracket models work with any top that has a 5" x 5" square clearance. • Worksurface clamp models work on any top with a 4" overhang. • UL Listed. 				
Color finish coordinates with HON's Charcoal or White. Specify <i>STRM</i> for Storm or <i>SNW</i> for Snow when ordering. Example: HPWRMOD3WC.STRM.				
Power & Data Center				
2 Receptacles 2 Data Accessory	HCOMDOME2	2.5	0.2	\$296
<ul style="list-style-type: none"> • Standard with two receptacles and openings for two data ports. • 6' power cord with standard three-prong plug. • Fits on any worksurface with a 4" overhang. • UL Listed. 				
Color finish coordinates with HON's Loft. Specify <i>LOFT</i> when ordering. Example: HCOMDOME2.LOFT.				
Under Worksurface Power Module — 4 Outlets, 10' Cord				
	HPWRMOD2	1.5	0.2	\$401
<ul style="list-style-type: none"> • Includes 10' cord with three-prong plug. • Fits in cable management troughs. See page 233. • 4 outlets on side create easy access. 				
NOTES: Power Modules will also work with standing-height applications for 10500 Series™ and Voi® desks.				
Available in black finish only, no specification needed.				
Vertebrae				
	HMPVWM28	3.0	0.3	\$223
NOTES: 30"H x 3 1/8"W x 1 1/2"D. Ships unassembled.				
Clear finish. Specify "X" for finish option. SPECIFYING EXAMPLE: HMPVWM28.X				

NOTES:

- For additional information see the Workplace Tools section in the 2021 Shared Spaces Pricer.

HOW TO SPECIFY

Select
Model Number

H P W R M O D 3 W C

10500 SERIES™



10500 Series™ Workstation shown with Ignition® Seating.

10500 SERIES™

Endlessly adaptable and unexpectedly affordable, our 10500 Series offers truly lasting value. The versatile design and options give you an even wider range of layout possibilities and the flexibility to maximize footprints — even smaller ones. And with more ways to customize your personal storage, the 10500 Series simply gives you more for less.



FEATURES

- The 10500 Series' fresh aesthetic includes airy H- or O-legs and frosted modesty panels.
- Available in 25 durable mix-and-match laminates, including new textured styles.
- With so many convenient and compact storage options, even the smallest footprints feel big.
- The versatile 10500 Series™ offers a variety of components to accommodate any size workspace.
- Support today's healthy work styles by offering the choice of sitting or standing while working, with storage options that fit your needs.

10500 SERIES™ ORDERING INFORMATION

LAMINATE TOP, CHASSIS, AND WORKSURFACES

L1 LAMINATES CODES

Woodgrain

- ◆ Bourbon Cherry H
- ◆ Cognac COGN
- ◆ Florence Walnut LFW1
- ◆ Harvest C
- ◆ Kingswood Walnut LK11
- ◆ Mahogany N
- ◆ Mocha MOCH
- ◆ Natural Maple D
- ◆ Pinnacle PINC
- ◆ Shaker Cherry F
- ◆ Sterling Ash LSA1

Solid

- ◆ Black P
- ◆ Charcoal S
- ◆ Designer White LDW1
- ◆ Loft LOFT

Patterned Top

- ◆ Grey Tigris L6
- ◆ Sheer Mesh A5
- ◆ Silver Mesh B9
- ◆ Canyon Zephyr K9
- ◆ Desert Zephyr K8

L2 LAMINATES CODES

Woodgrain

- ◆ Lowell Ash LLA1
- ◆ Natural Recon LNRI
- ◆ Phantom Ecreu LPE1
- ◆ Portico Teak LPT1
- ◆ Skyline Walnut LSW1

EDGE BAND

EDGE BAND COLORS CODES

Woodgrain

- ◆ Bourbon Cherry H
- ◆ Cognac COGN
- ◆ Florence Walnut FW
- ◆ Harvest C
- ◆ Kingswood Walnut KI
- ◆ Lowell Ash DL
- ◆ Mahogany N
- ◆ Mocha MOCH
- ◆ Natural Maple D
- ◆ Natural Recon NR
- ◆ Phantom Ecreu PE
- ◆ Pinnacle PINC
- ◆ Portico Teak DP
- ◆ Shaker Cherry F
- ◆ Skyline Walnut SW
- ◆ Sterling Ash SA

Solid

- ◆ Black P
- ◆ Charcoal S
- ◆ Designer White DW
- ◆ Loft LOFT

10500 SERIES™ MOBILE TABLES

PAINTS CODES

P1

- ◆ Black P
- ◆ Brownstone P7D
- ◆ Charcoal S
- ◆ Designer White PJW
- ◆ Fossil P28
- ◆ Greige T5
- ◆ Loft LOFT
- ◆ Muslin T3
- ◆ Titanium P8T

P2

- ◆ Champagne Metallic T4
- ◆ Platinum Metallic T1
- ◆ Silver PR6

H-LEGS, O-LEGS, POST LEGS, STORAGE CUBE

PAINTS CODES

P1

- ◆ Black P
- ◆ Brownstone P7D
- ◆ Charcoal S
- ◆ Designer White PJW
- ◆ Fossil P28
- ◆ Greige T5
- ◆ Loft LOFT
- ◆ Muslin T3
- ◆ Shadow* SHDW
- ◆ Titanium P8T

P2

- ◆ Champagne Metallic T4
- ◆ Platinum Metallic T1
- ◆ Silver PR6
- ◆ Solar Black P8X

P3

- ◆ Atom P8S
- ◆ Blossom P8K
- ◆ Bullseye PJF
- ◆ Cabernet P7T
- ◆ Conifer P8H
- ◆ Ember P8P
- ◆ Ion P8N
- ◆ Iris P8J
- ◆ Krypton P8F
- ◆ Regatta P8M
- ◆ Succulent P8A

◆◆◆ For lead time information see page 19.

* De-emphasized

Patterned Top

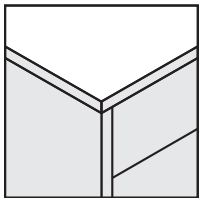

Edgeband Around Top / Laminate Chassis

- Edgebanding on patterned laminates matches the laminate chassis selected.
- Patterned top laminates are available with the following edgeband laminate selection: C, COGN, D, F, FW, H, KI, DW, MOCH, N, P, PINC, SA, and S.
- For 10500 Series™ worksurface models, the finish specification options include matching the top and edgeband colors or choosing a two-tone combination.

LAMINATE DESKS

SPECIFY: Model Number.
Laminate

EXAMPLE: H105413.NN

WORKSURFACES

SPECIFY: Model Number.
Top Laminate
Edgeband

- All specifications in this publication are based on the latest product information available at the time of print.

! Tops with a patterned color are not available with a matching edgeband.

10500 SERIES™ ORDERING INFORMATION

TWO-TONE LAMINATE TOP / CHASSIS

L1 LAMINATES	CODES
Two-Tone Top/Chassis	
◆ Black/Charcoal	PS
◆ Black/Designer White	PLDW1
◆ Black/Loft	PLOFT
◆ Bourbon Cherry/Black	HP
◆ Bourbon Cherry/Charcoal	HS
◆ Bourbon Cherry/Designer White	HLDW1
◆ Bourbon Cherry/Loft	HLOFT
◆ Charcoal/Black	SP
◆ Charcoal/Designer White	SLDW1
◆ Charcoal/Loft	SLOFT
◆ Cognac/Black	COGNP
◆ Cognac/Charcoal	COGNS
◆ Cognac/Designer White	COGNLDW1
◆ Cognac/Loft	COGNLOFT
◆ Designer White/Black	LDW1P
◆ Designer White/Bourbon Cherry	LDW1H
◆ Designer White/Charcoal	LDW1S
◆ Designer White/Cognac	LDW1COGN
◆ Designer White/Florence Walnut	LDW1LFW1
◆ Designer White/Harvest	LDW1C
◆ Designer White/Kingswood Walnut	LDW1LKI1
◆ Designer White/Loft	LDW1LOFT
◆ Designer White/Mahogany	LDW1N
◆ Designer White/Mocha	LDW1MOCH
◆ Designer White/Natural Maple	LDW1D
◆ Designer White/Pinnacle	LDW1PINC

TWO-TONE LAMINATE TOP / CHASSIS *continued*

L1 LAMINATES	CODES
Two-Tone Top/Chassis	
◆ Designer White/Shaker Cherry	LDW1F
◆ Designer White/Sterling Ash	LDW1LSA1
◆ Florence Walnut/Black	LFW1P
◆ Florence Walnut/Charcoal	LFW1S
◆ Florence Walnut/Designer White	LFW1LDW1
◆ Florence Walnut/Loft	LFW1LOFT
◆ Harvest/Black	CP
◆ Harvest/Charcoal	CS
◆ Harvest/Designer White	CLDW1
◆ Harvest/Loft	CLOFT
◆ Kingswood Walnut/Black	LKI1P
◆ Kingswood Walnut/Charcoal	LKI1S
◆ Kingswood Walnut/Designer White	LKI1LDW1
◆ Kingswood Walnut/Loft	LKI1LOFT
◆ Loft/Black	LOFTP
◆ Loft/Charcoal	LOFTS
◆ Loft/Designer White	LOFTLDW1
◆ Mahogany/Black	NP
◆ Mahogany/Charcoal	NS
◆ Mahogany/Designer White	NLDW1
◆ Mahogany/Loft	NLOFT
◆ Mocha/Black	MOCHP
◆ Mocha/Charcoal	MOCHS
◆ Mocha/Designer White	MOCHLDW1
◆ Mocha/Loft	MOCHLOFT

TWO-TONE LAMINATE TOP / CHASSIS *continued*

L1 LAMINATES	CODES
Two-Tone Top/Chassis	
◆ Natural Maple/Black	DP
◆ Natural Maple/Charcoal	DS
◆ Natural Maple/Designer White	DLDW1
◆ Natural Maple/Loft	DLOFT
◆ Pinnacle/Black	PINCP
◆ Pinnacle/Charcoal	PINCS
◆ Pinnacle/Designer White	PINCLDW1
◆ Pinnacle/Loft	PINCLOFT
◆ Shaker Cherry/Black	FP
◆ Shaker Cherry/Charcoal	FS
◆ Shaker Cherry/Designer White	FLDW1
◆ Shaker Cherry/Loft	FLOFT
◆ Sterling Ash/Black	LSA1P
◆ Sterling Ash/Charcoal	LSA1S
◆ Sterling Ash/Designer White	LSA1LDW1
◆ Sterling Ash/Loft	LSA1LOFT

L2 LAMINATES

L2 LAMINATES	CODES
Two-Tone Top/Chassis	
◆ Designer White/Lowell Ash	LDWILLA1
◆ Designer White/Natural Recon	LDWILNR1
◆ Designer White/Phantom Ecru	LDW1PE1
◆ Designer White/Portico Teak	LDW1LPT1
◆ Designer White/Skyline Walnut	LDW1LSW1
◆ Lowell Ash/Black	LLA1P
◆ Lowell Ash/Charcoal	LLA1S
◆ Lowell Ash/Designer White	LLA1LDW1
◆ Lowell Ash/Loft	LLA1LOFT
◆ Natural Recon/Black	LNR1P
◆ Natural Recon/Charcoal	LNR1S
◆ Natural Recon/Designer White	LNR1LDW1
◆ Natural Recon/Loft	LNR1LOFT

TWO-TONE LAMINATE TOP / CHASSIS *continued*

L2 LAMINATES	CODES
Two-Tone Top/Chassis	
◆ Phantom Ecru/Black	LPE1P
◆ Phantom Ecru/Charcoal	LPE1S
◆ Phantom Ecru/Designer White	LPE1LDW1
◆ Phantom Ecru/Loft	LPE1LOFT
◆ Portico Teak/Black	LPT1P
◆ Portico Teak/Charcoal	LPT1S
◆ Portico Teak/Designer White	LPT1LDW1
◆ Portico Teak/Loft	LPT1LOFT
◆ Skyline Walnut/Black	LSW1P
◆ Skyline Walnut/Charcoal	LSW1S
◆ Skyline Walnut/Designer White	LSW1LDW1
◆ Skyline Walnut/Loft	LSW1LOFT

HLAM3772RD, HLAM3348RR

EDGEBAND COLORS

EDGEBAND COLORS	CODES
Woodgrain	
◆ Bourbon Cherry	H
◆ Cognac	COGN
◆ Florence Walnut	FW
◆ Harvest	C
◆ Kingswood Walnut	KI
◆ Lowell Ash	DL
◆ Mahogany	N
◆ Mocha	MOCH
◆ Natural Maple	D
◆ Natural Recon	NR
◆ Phantom Ecru	PE
◆ Pinnacle	PINC
◆ Portico Teak	DP
◆ Shaker Cherry	F
◆ Skyline Walnut	SW
◆ Sterling Ash	SA
Solid	
◆ Black	P
◆ Charcoal	S
◆ Designer White	DW
◆ Loft	LOFT

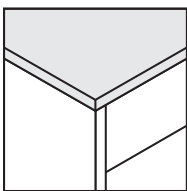

Laminate Chassis

Two-tone laminates: Top and edgebanding are the same, chassis is different laminate color.

The following 10500 Series™ products are not available as two-tone. They are one color and require only one color code:

- Modular pedestals — box/file, box/box/file, file/file, lateral file, multi file, and cabinet (also applies to Valido/11500 Series).
- Access strip and end panel kits
- Back enclosures
- Wall mounted open shelf
- Reception stations for return
- T-shaped end panels
- L-shaped end panels

Storage chassis that are specified in L2 laminates and are longer than 60" W will ship with back panels that are horizontal grain.

- Edgebanding on two-tone laminates matches top, chassis is a different laminate color.
- A complete selection of Conference Room and Occasional Tables is shown in the Tables section of the 2021 Shared Spaces Pricer.

LAMINATE DESKS

SPECIFY: Model Number.

Laminate

EXAMPLE: H10596.HP

- All specifications in this publication are based on the latest product information available at the time of print.

◆◆◆ For lead time information see page 19.

10500 SERIES™

Typicals



Icon Legend on page 19

Components used are listed on pages 244-295. Order components individually. Other configurations are possible, including various sizes of some components.

QTY	DESCRIPTION	MODEL	LIST PRICE	PRICE EXTENSION
1	Rectangle Worksurface 78"W x 30"D	H105R3078	\$429	\$429
1	O-Leg 30"D x 28½"H	HLSL30280	\$359	\$359
1	Low Credenza 72"W x 20"D x 21½"H, Drawers Right, Bookcase Left	H105975R	\$1,324	\$1,324
1	O-Leg Support over Low Credenza 30"D x 7"H	HLSL3070	\$277	\$277
1	Multi-Use Stack-On Storage 36"W x 18"D x 45⅝"H	H105310	\$1,059	\$1,059
TOTAL:			\$3,448	

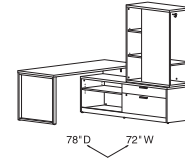

DESK L-WORKSTATION
72\"/>

QTY	DESCRIPTION	MODEL	LIST PRICE	PRICE EXTENSION
1	Rectangle Worksurface 72"W x 30"D	H105R3072	\$402	\$402
1	Modesty/Back Panels - Full Length 72"W x 27⅞"H	HNLMP7228	\$292	\$292
1	Coordinate™ Height Adjustable Base	HHAB2S2L	\$1,006	\$1,006
2	Shroud for Height Adjustable Base	HLAMSHB30	\$848	\$1,696
1	Credenza with Doors 72"W x 24"D x 29½"H	H105909	\$1,827	\$1,827
1	Stack-On Storage 72"W x 14⅝"D x 37⅞"H, 4 Doors	H10534	\$1,011	\$1,011
1	External Stiffener 60"W for 72"W Worksurfaces	HLSLZ55C72	\$110	\$110
TOTAL:			\$6,344	

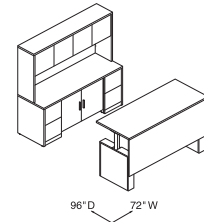

HEIGHT ADJUSTABLE TABLE
WORKSTATION WITH STACK-ON
STORAGE
72\"/>

QTY	DESCRIPTION	MODEL	LIST PRICE	PRICE EXTENSION
1	Single Pedestal Desk, Left - B/F 66"W x 30"D x 29½"H	H10584L	\$1,039	\$1,039
1	Return, Right - B/F 42"W x 24"D x 29½"H	H10511R	\$819	\$819
1	Stack-on Storage 72"W x 14⅝"D x 37⅞"H	H10534	\$1,011	\$1,011
TOTAL:			\$2,869	

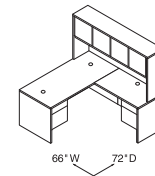

DESK "L" WORKSTATION - RIGHT
66\"/>

QTY	DESCRIPTION	MODEL	LIST PRICE	PRICE EXTENSION
1	Double Full Pedestal Desk - 3/2 72"W x 36"D x 29½"H	H105890	\$1,702	\$1,702
1	Credenza with Kneespace - 2/0/2 72"W x 24"D x 29½"H	H105900	\$1,493	\$1,493
1	Stack-on Storage, Frosted Doors with Silver Frame 72"W x 14⅝"D x 37⅞"H	H10534G	\$1,659	\$1,659
TOTAL:			\$4,854	

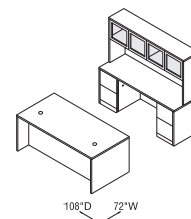

DESK/CREDENZA/STACK-ON STORAGE
WITH FROSTED DOORS
72\"/>



Icon Legend on page 19

10500 SERIES™ Typicals

DESKS

Components used are listed on pages 244-295. Order components individually. Other configurations are possible, including various sizes of some components.

QTY	DESCRIPTION	MODEL	LIST PRICE	PRICE EXTENSION
1	Storage/File Cabinet 18"W x 24"D x 66 ⁵ / ₈ "H, Hinged Right	H105297R	\$1,692	\$1,692
1	Open Credenza 36"W x 24"D x 21 ¹ / ₂ "H	H105LCHAT3024S	\$220	\$220
1	Open/Lateral Credenza 30"W x 24"D x 21 ¹ / ₂ "H	H105LC3024SF	\$490	\$490
1	Modular Credenza Top 60"W x 24"D	H105CTHAT6024L	\$683	\$683
1	Wall Mounted Open Hutch, Cubby w/Glass Doors 60"W x 14 ⁵ / ₈ "D x 20"H	H105WMH60PCG	\$1,661	\$1,661
1	Height Adjustable Base 24"D	HHAB3S2L	\$1,120	\$1,120
1	Shroud for Height Adjustable Base 5 ¹ / ₈ "W x 26"D x 26 ¹ / ₄ "H	HLAMSHB30	\$848	\$848
1	Rectangle Worksurface 66"W x 30"D	H105R3066	\$374	\$374
1	Mixed Material Floating Modesty Panel 36"W x 14"H	HLSL3614MM	\$739	\$739
TOTAL:			\$7,827	

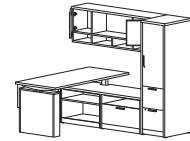

**HEIGHT ADJUSTABLE
"L" WORKSTATION**
66"W x 78"D

QTY	DESCRIPTION	MODEL	LIST PRICE	PRICE EXTENSION
1	H-Leg Support 30"W x 28 ³ / ₈ "H	H105HLEG3028	\$352	\$352
1	Rectangle Worksurface 66"W x 30"D	H105R3066	\$374	\$374
1	External Channel 54"W	HLSLZ5SC66	\$101	\$101
1	Flat Bracket 24"D	HHN831124	\$64	\$64
1	Return Shell w/Full Modesty Panel 72"W x 24"D x 29 ¹ / ₂ "H	H105686	\$696	\$696
1	Multi File Pedestal, Floor-Standing 36"W x 20"D x 28"H	H10505	\$1,249	\$1,249
1	Personal Storage Tower, Hinged Right 24"W x 24"D x 66 ⁵ / ₈ "H	H105301R	\$2,139	\$2,139
1	Wall Mounted Open Hutch 72"W x 14 ⁵ / ₈ "D x 15"H	H105WMH72P	\$1,400	\$1,400
1	Laminate Floating Modesty Panel 54"W x 14"H	HLSL5414L	\$235	\$235
TOTAL:			\$6,610	

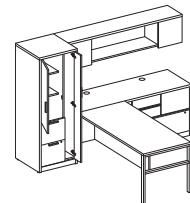

**EXTENDED STORAGE
"L" WORKSTATION**
66"W x 96"D

QTY	DESCRIPTION	MODEL	LIST PRICE	PRICE EXTENSION
1	Single Full Pedestal Desk, Right - B/B/F 72"W x 36"D x 29 ¹ / ₂ "H	H105895R	\$1,361	\$1,361
1	Bridge 47"W x 24"D x 29 ¹ / ₂ "H	H10570	\$364	\$364
1	Single Full Pedestal Credenza, Left - F/F 72"W x 24"D x 29 ¹ / ₂ "H	H105904L	\$1,210	\$1,210
1	Stack-on Storage 72"W x 14 ⁵ / ₈ "D x 37 ¹ / ₈ "H	H10534	\$1,011	\$1,011
TOTAL:			\$3,946	

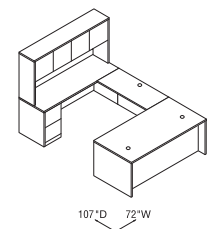

**"U" WORKSTATION
WITH FULL PEDESTALS**
72"W x 107"D

10500 SERIES™

Typicals



Icon Legend on page 19

Components used are listed on pages 244-295. Order components individually. Other configurations are possible, including various sizes of some components.

QTY	DESCRIPTION	MODEL	LIST PRICE	PRICE EXTENSION
1	Rudder Peninsula with End Panel, Right 72"W x 30/38"D x 29½"H	H105205R	\$1,113	\$1,113
1	Return, Left - F/F 42"W x 24"D x 29½"H	H105908L	\$941	\$941
1	Stack-on Storage 72"W x 14⅝"D x 37⅞"H	H10534	\$1,011	\$1,011
TOTAL:			\$3,065	

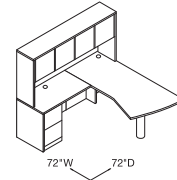

PENINSULA "L" WORKSTATION

72" W x 72" D

QTY	DESCRIPTION	MODEL	LIST PRICE	PRICE EXTENSION
1	Peninsula with End Panel 72"W x 36"D x 29½"H	H10521	\$877	\$877
1	Bridge 42"W x 24"D x 29½"H	H10560	\$350	\$350
1	Extended Corner Unit, Left 72"W x 24"-36"D x 29½"H	H105816L	\$1,074	\$1,074
1	Mobile Pedestal - B/B/F 15¾"W x 22¾"D x 28"H	H105102	\$854	\$854
1	Stack-on Storage 72"W x 14⅝"D x 37⅞"H	H10534	\$1,011	\$1,011
1	Storage Cabinet/Lateral File 36"W x 24"D x 66⅝"H	H105293	\$2,278	\$2,278
TOTAL:			\$6,444	

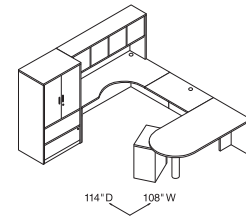

PENINSULA "U" WORKSTATION - LEFT

108" W x 114" D

QTY	DESCRIPTION	MODEL	LIST PRICE	PRICE EXTENSION
1	Slide Out Tower, Left Hinged 12"W x 24"D x 50"H	H105ST122450L	\$2,705	\$2,705
1	Open Credenza 30"W x 24"D x 21½"H	H105LCHAT3024S	\$220	\$220
1	Open/Lateral Credenza 30"W x 24"D x 21½"H	H105LC3024SF	\$490	\$490
1	Modular Credenza Top 60"W x 24"D	H105CTHAT6024R	\$683	\$683
1	Height Adjustable Base 24"D	HHAB3S2L	\$1,120	\$1,120
1	Shroud for Height Adjustable Base 5⅞"W x 26"D x 26¼"H	HLAMSHB30	\$848	\$848
1	Rectangle Worksurface 66"W x 30"D	H105R3066	\$374	\$374
1	Laminate Floating Modesty Panel 30"W x 14"H	HLSL3014L	\$173	\$173
1	2-Drawer Credenza 30"W x 24"D x 21½"H	H105LC3024BF	\$556	\$556
1	Modular Credenza Top 30"W x 24"D	H105CT3024	\$395	\$395
1	Fabric Credenza Top 30"W x 24"D	HLAMSEAT3024	\$405	\$405
TOTAL:			\$7,969	

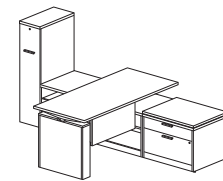

**HEIGHT ADJUSTABLE "L" WORKSTATION
WITH SLIDE OUT STORAGE**

66" W x 102" D



Icon Legend on page 19

10500 SERIES™ Bundles Typicals

Mahogany
H105LL7284N

Harvest
H105LL7284C

QTY	DESCRIPTION	MODEL	LIST PRICE	PRICE EXTENSION
1	Left Pedestal Desk	H10586L	\$1,182	\$1,182
1	Right Return	H10515R	\$837	\$837
TOTAL:			\$2,019	

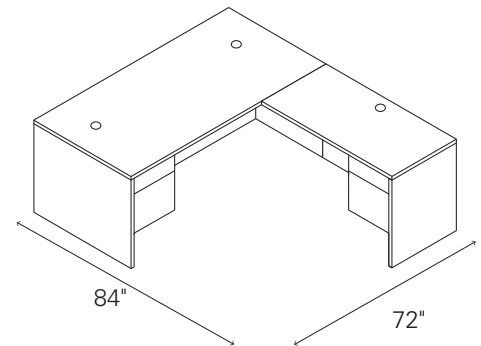

L-STATION (LEFT DESK/RIGHT RETURN)

Mahogany
H105LR7284N

Harvest
H105LR7284C

QTY	DESCRIPTION	MODEL	LIST PRICE	PRICE EXTENSION
1	Right Pedestal Desk	H10585R	\$1,182	\$1,182
1	Left Return	H10516L	\$837	\$837
TOTAL:			\$2,019	

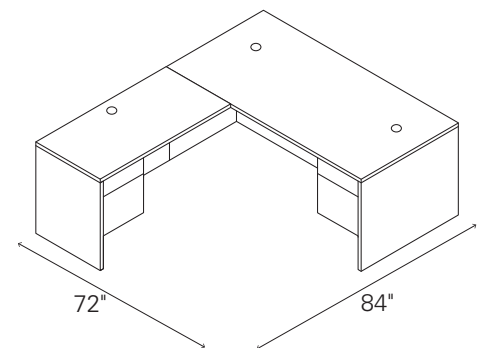

L-STATION (RIGHT DESK/LEFT RETURN)

Mahogany
H105LLH7284N

Harvest
H105LLH7284C

QTY	DESCRIPTION	MODEL	LIST PRICE	PRICE EXTENSION
1	Left Pedestal Desk	H10586L	\$1,182	\$1,182
1	Right Return	H10515R	\$837	\$837
1	Stack-on Storage	H105323	\$850	\$850
TOTAL:			\$2,869	

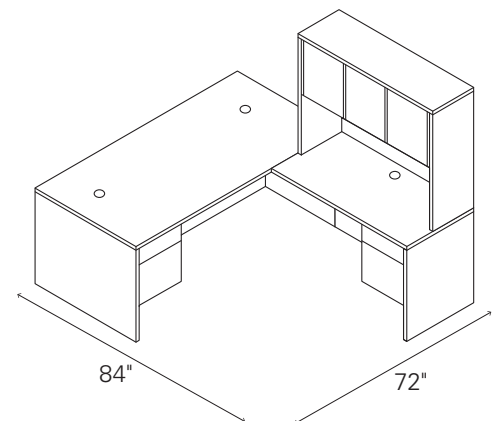

**L-STATION WITH STACK-ON STORAGE
(LEFT DESK/RIGHT RETURN)**

10500 SERIES™ Bundles Typicals



Icon Legend on page 19

Mahogany
H105LRH7284N

Harvest
H105LRH7284C

QTY	DESCRIPTION	MODEL	LIST PRICE	PRICE EXTENSION
1	Right Pedestal Desk	H10585R	\$1,182	\$1,182
1	Left Return	H10516L	\$837	\$837
1	Stack-on Storage	H105323	\$850	\$850
TOTAL:			\$2,869	

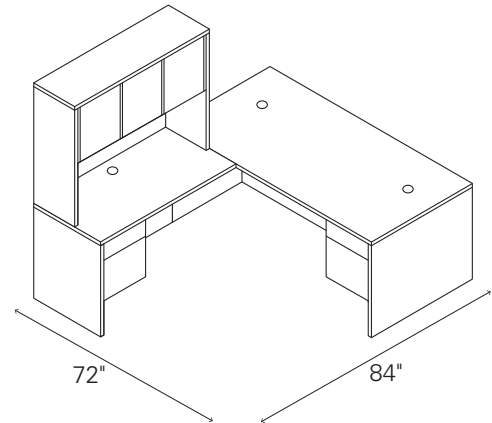

**L-STATION WITH STACK-ON STORAGE
(RIGHT DESK/LEFT RETURN)**

Mahogany
H105ULH72108N

Harvest
H105ULH72108C

QTY	DESCRIPTION	MODEL	LIST PRICE	PRICE EXTENSION
1	Left Pedestal Desk	H10586L	\$1,182	\$1,182
1	Right Pedestal Credenza	H10545R	\$1,023	\$1,023
1	Bridge	H10570	\$364	\$364
1	Stack-on Storage	H10534	\$1,011	\$1,011
TOTAL:			\$3,580	

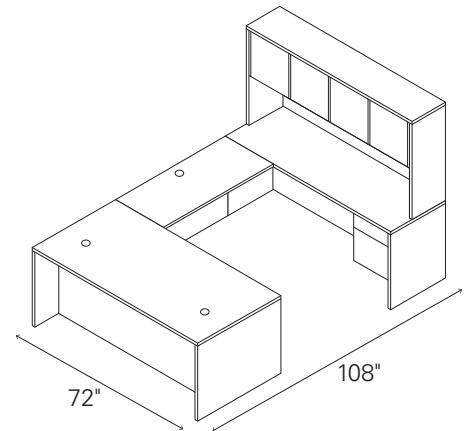

**U-STATION WITH STACK-ON STORAGE
(LEFT DESK/RIGHT CREDENZA)**

Mahogany
H105URH72108N

Harvest
H105URH72108C

QTY	DESCRIPTION	MODEL	LIST PRICE	PRICE EXTENSION
1	Right Pedestal Desk	H10585R	\$1,182	\$1,182
1	Left Pedestal Credenza	H10546L	\$1,023	\$1,023
1	Bridge	H10570	\$364	\$364
1	Stack-on Storage	H10534	\$1,011	\$1,011
TOTAL:			\$3,580	

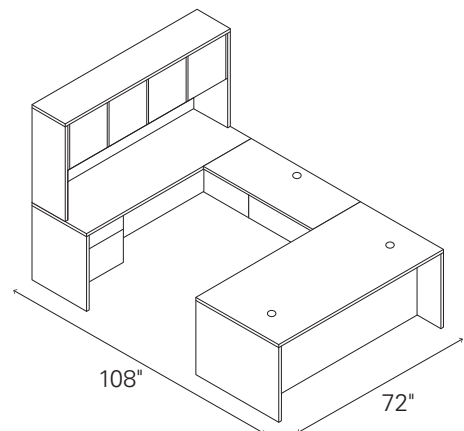

**U-STATION WITH STACK-ON STORAGE
(RIGHT DESK/LEFT CREDENZA)**



Icon Legend on page 19

10500 SERIES™ Bundles Typicals

Mahogany
H105DLH7298N

Harvest
H105DLH7298C

QTY	DESCRIPTION	MODEL	LIST PRICE	PRICE EXTENSION
1	Double Pedestal Desk	H10593	\$1,391	\$1,391
2	Bookcase Hutch	H105292	\$570	\$1,140
1	2-Drawer Lateral File	H10563	\$973	\$973
1	Storage Cabinet with Doors	H105291	\$781	\$781
TOTAL:			\$4,285	

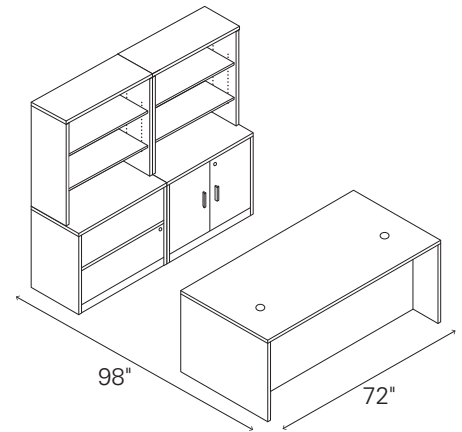

STORAGE WORKSTATION

Mahogany
H105DCH6098N

Harvest
H105DCH6098C

QTY	DESCRIPTION	MODEL	LIST PRICE	PRICE EXTENSION
1	Double Pedestal Desk	H10573	\$1,172	\$1,172
1	Double Pedestal Credenza	H10565	\$1,172	\$1,172
1	Stack-on Storage	H105324	\$943	\$943
TOTAL:			\$3,287	

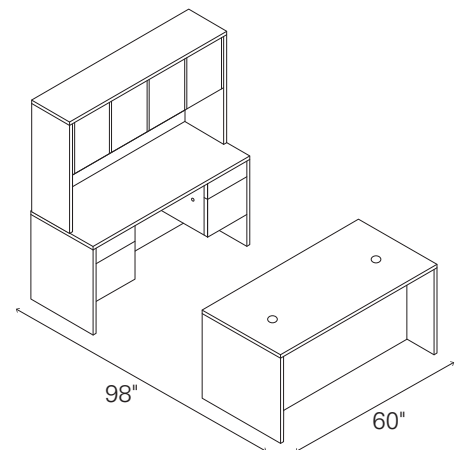

DESK CREDENZA STACK-ON #1

Mahogany
H105DCH7298N

Harvest
H105DCH7298C

QTY	DESCRIPTION	MODEL	LIST PRICE	PRICE EXTENSION
1	Double Pedestal Desk	H10593	\$1,391	\$1,391
1	Double Pedestal Credenza	H10543	\$1,240	\$1,240
1	Stack-on Storage	H10534	\$1,011	\$1,011
TOTAL:			\$3,642	

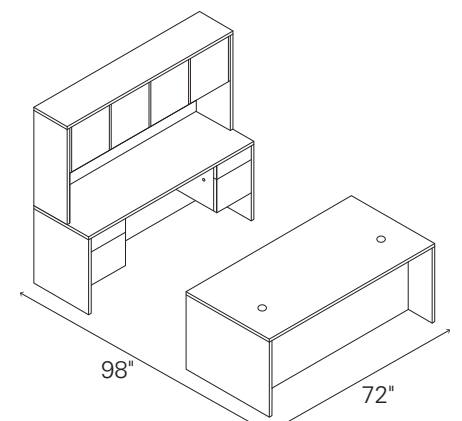

DESK CREDENZA STACK-ON #2

10500 SERIES™ Laminate Modular Components

GSA SIN 33721



Icon Legend on page 19

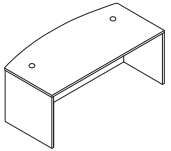

Model H10596 shown

DESCRIPTION	INSIDE DIMENSIONS	FULL WIDTH OVERHANG	MODEL	SHIP WEIGHT	CUBE	LIST PRICE BY LAMINATE GRADE	
						L1	L2
Desk Shell (with full modesty panel and 2 grommets)							
72"W x 36"D x 29½"H, Bow Top (end panels 30"D)	69½"W x 24⅝"D	10½"	H10596	192	6.9	\$894	\$944
72"W x 36"D x 29½"H, Rectangle Top	69½"W x 24⅝"D	10½"	H10594	209	6.9	\$807	\$857
72"W x 30"D x 29½"H, Rectangle Top	69½"W x 24⅝"D	4½"	H10592	182	5.8	\$765	\$805
66"W x 30"D x 29½"H, Rectangle Top	63½"W x 24⅝"D	4½"	H10579	172	5.4	\$725	\$765
60"W x 30"D x 29½"H, Rectangle Top	57½"W x 24⅝"D	4½"	H10578	161	5.0	\$674	\$714
48"W x 30"D x 29½"H, Rectangle Top (1 grommet)	45½"W x 24⅝"D	4½"	H10598	141	5.0	\$626	\$656
NOTES: See page 295 for optional center drawers.							
Desk Shell (with 10"H modesty panel and 2 grommets)							
72"W x 36"D x 29½"H, Bow Top (end panels 30"D)	69½"W x 24⅝"D	10½"	H10596X	155	6.1	\$894	\$944
72"W x 36"D x 29½"H, Rectangle Top	69½"W x 24⅝"D	10½"	H10594X	153	6.1	\$807	\$857
72"W x 30"D x 29½"H, Rectangle Top	69½"W x 24⅝"D	4½"	H10592X	143	5.1	\$765	\$805
66"W x 30"D x 29½"H, Rectangle Top	63½"W x 24⅝"D	4½"	H10579X	134	4.7	\$725	\$765
60"W x 30"D x 29½"H, Rectangle Top	57½"W x 24⅝"D	4½"	H10578X	125	4.4	\$674	\$714
48"W x 30"D x 29½"H, Rectangle Top (1 grommet)	45½"W x 24⅝"D	4½"	H10598X	115	4.4	\$626	\$656
NOTES: Makes reaching wall electrical outlets quick and easy. Provides more than 18" of clearance. See pages 272-273 for optional stack-on storage and page 295 for optional center drawers.							

NOTES:

- Non-handed desk, credenza, and return shells, combined with a variety of under-the-worksurface storage solutions, maximize office layout flexibility. Products can be reconfigured quickly and easily when user preferences or space needs change.
- For under-surface storage options, see pages 259-261.
- For additional components see pages 268-295.
- Tops and end panels are abrasion- and stain-resistant laminate over durable 1⅝" solid core high-performance particleboard; resists warping.
- Cord management grommets, for routing and hiding wires and cables, are located in the tops of desks and return shells.
- 3" round worksurface grommet can be replaced with optional Power Hub (model HGRMTAC) or Power/USB Hub (model HGRMTUSB2) to bring the ease of plug-and-play to the desktop. See page 294.
- Adjustable hex leveling glides allow floor-standing furniture to be easily leveled without lifting the unit; glides have ¾" adjustable range.
- For standing, 42"H shells, see page 247.

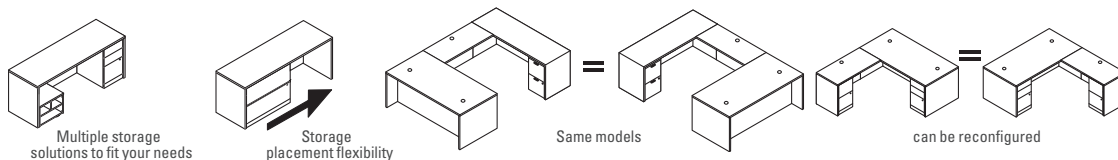

HOW TO SPECIFY

<p>Select Model Number</p> <p>H 1 0 5 9 6 .</p>	<p>Select Laminate Top and Chassis Color</p> <p>See pages 236-237</p> <p>N N</p>
--	---



10500 SERIES™

Laminate Modular Components

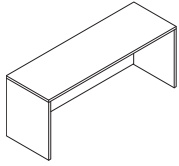

DESCRIPTION	INSIDE DIMENSIONS	MODEL	SHIP WEIGHT	CUBE	LIST PRICE BY LAMINATE GRADE	
					L1	L2
Credenza Shell (with full modesty panel)						
72"W x 24"D x 29½"H	69½"W x 22¾"D	H10541	153	5.6	\$696	\$736
66"W x 24"D x 29½"H	63½"W x 22¾"D	H10542	144	5.1	\$681	\$721
60"W x 24"D x 29½"H	57½"W x 22¾"D	H10564	135	4.7	\$637	\$672
48"W x 24"D x 29½"H	45½"W x 22¾"D	H105692	124	3.9	\$610	\$640
42¼"W x 24"D x 29½"H	39¾"W x 22¾"D	H105691	110	3.8	\$590	\$620
72"W x 20"D x 29½"H	69½"W x 18¾"D	H105581	138	5.6	\$657	\$692
66"W x 20"D x 29½"H	63½"W x 18¾"D	H105582	130	5.1	\$641	\$676
60"W x 20"D x 29½"H	57½"W x 18¾"D	H105583	122	4.7	\$608	\$638

NOTES: Cord pass-through in top center of modesty panel. See pages 272-273 for optional stack-on storage.

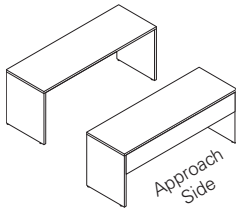

DESCRIPTION	INSIDE DIMENSIONS	MODEL	SHIP WEIGHT	CUBE	LIST PRICE BY LAMINATE GRADE	
					L1	L2
Credenza Shell (with 10" H modesty panel)						
72"W x 24"D x 29½"H	69½"W x 22¾"D	H10541X	114	4.8	\$696	\$736
66"W x 24"D x 29½"H	63½"W x 22¾"D	H10542X	107	4.4	\$681	\$721
60"W x 24"D x 29½"H	57½"W x 22¾"D	H10564X	105	4.0	\$637	\$672
48"W x 24"D x 29½"H	45½"W x 22¾"D	H105692X	95	3.8	\$610	\$640
42¼"W x 24"D x 29½"H	39¾"W x 22¾"D	H105691X	87	3.8	\$590	\$620
72"W x 20"D x 29½"H	69½"W x 18¾"D	H105581X	107	4.8	\$657	\$692
66"W x 20"D x 29½"H	63½"W x 18¾"D	H105582X	101	4.4	\$641	\$676
60"W x 20"D x 29½"H	57½"W x 18¾"D	H105583X	96	4.0	\$608	\$638

NOTES: Makes reaching wall electrical outlets quick and easy. Provides more than 18" of clearance. See pages 272-273 for optional stack-on storage.



Not available in two-tone laminate

DESCRIPTION	MODEL	SHIP WEIGHT	CUBE	L1	L2
				LIST PRICE	LIST PRICE
Kneespace Clearance End Panel Kits (field installable)					
1½"W x 11¼"D x 28½"H	H105098	13	0.9	\$210	\$220
For use at either end of 10500, 10700 or Valido Series® 24"D Credenza Shells (with full or 10" modesty panel) or non-pedestal end of single pedestal credenzas or credenzas with lateral files.					
1½"W x 17¼"D x 28½"H	H105099	11	0.8	\$220	\$230
For use at either end of 10500, 10700 or Valido Series® 30"D Desk Shells or non-pedestal end of 30"D single pedestal desks.					
Kits include: (1) support panel; European fastening hardware; flat connector bracket; joint connector bolts with sleeve nuts (for ganging credenza to adjacent worksurface); and adjustable leveling glides. Allows conversion of units currently in the field.					
NOTES: Can be used to connect up to three 24"D credenzas or 30"D desks in line (requires 4 kits).					
⚠ Not designed to be used freestanding. Not designed to be used with returns, 36"D desks or desk shells.					
SPECIFYING EXAMPLE: H105098.N					

NOTES:

- Non-handed desk, credenza, and return shells, combined with a variety of under-the-worksurface storage solutions, maximize office layout flexibility. Products can be reconfigured quickly and easily when user preferences or space needs change.
- For 78", 84", 90", and 96"W credenza shells, see page 246.
- For under-surface storage options, see pages 259-261.
- Tops and end panels are abrasion- and stain-resistant laminate over durable 1/8" solid core high-performance particleboard; resists warping.
- For additional components see pages 268-295.
- For work-in-process paper management tools, see pages 289-290.
- Cord management grommets, for routing and hiding wires and cables, are located in the tops of desks and return shells.
- Credenza shells have a cord pass-through grommet in the top center of the modesty panel.
- Kneespace Clearance End Panel Kit model H105098, can be used to create "L" configurations with leg clearance, by connecting credenzas to single pedestal desks or credenzas, desk or credenza shells, corners, extended corners or peninsulas.
- Adjustable hex leveling glides allow floor-standing furniture to be easily leveled without lifting the unit; glides have ¾" adjustable range.

HOW TO SPECIFY

Select Model Number <input type="text" value="H10541"/>	Select Laminate Top and Chassis Color See pages 236-237 <input type="text" value="NN"/>
---	--

10500 SERIES™

Laminate Modular Components

GSA SIN 33721



Icon Legend on page 19

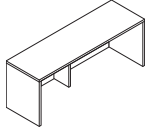

DESCRIPTION	INSIDE DIMENSIONS	MODEL	SHIP WEIGHT	CUBE	LIST PRICE BY LAMINATE GRADE	
					L1	L2
Credenza Shell (with full modesty panel)						
96"W x 24"D x 29½"H	93½"W x 22¾"D	H105413	215	7.0	\$991	\$1046
90"W x 24"D x 29½"H	87½"W x 22¾"D	H105412	202	6.6	\$964	\$1014
84"W x 24"D x 29½"H	81½"W x 22¾"D	H105411	189	6.2	\$855	\$905
78"W x 24"D x 29½"H	75½"W x 22¾"D	H105410	176	5.8	\$832	\$877

NOTES: Larger sizes can be used in conjunction with a 10500 Series rectangle- or bullet-shaped worksurface, supported by an end panel, column or leg, to achieve a space efficient work wall configuration. Shells wider than 72" include an internal, 10½"D vertical support leg. The internal leg can be removed if it is replaced with a 10500 Series 28"H modular pedestal that is adjusted to support the credenza shell top. Cord pass-through in top center of modesty panel. See pages 272-273 for optional stack-on storage and the stack-on storage end panel kit (model H105349).

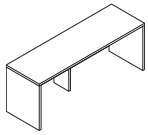

Credenza Shell (with 10"H modesty panel)						
96"W x 24"D x 29½"H	93½"W x 22¾"D	H105413X	163	6.1	\$991	\$1046
90"W x 24"D x 29½"H	87½"W x 22¾"D	H105412X	152	5.7	\$964	\$1014
84"W x 24"D x 29½"H	81½"W x 22¾"D	H105411X	141	5.4	\$855	\$905
78"W x 24"D x 29½"H	75½"W x 22¾"D	H105410X	130	5.0	\$832	\$877

NOTES: Makes reaching wall electrical outlets quick and easy. Provides more than 18" of clearance. Larger sizes can be used in conjunction with a 10500 Series rectangle- or bullet-shaped worksurface, supported by an end panel, column or leg, to achieve a space efficient work wall configuration. Shells wider than 72" include an internal, 10½"D vertical support leg. The internal leg can be removed if it is replaced with a 10500 Series 28"H modular pedestal that is adjusted to support the credenza shell top. See pages 272-273 for optional stack-on storage and the stack-on storage end panel kit (model H105349).

NOTES:

- Non-handed desk, credenza, and return shells, combined with a variety of under-the-worksurface storage solutions, maximize office layout flexibility. Products can be reconfigured quickly and easily when user preferences or space needs change.
- For under-surface storage options, see pages 259-261.
- For additional components see pages 268-295.
- Tops and end panels are abrasion- and stain-resistant laminate over durable 1½" solid core high-performance particleboard; resists warping.
- Credenza shells have a cord pass-through grommet in the top center of the modesty panel.
- Kneespace Clearance End Panel Kit model H105098, can be used to create "L" configurations with leg clearance, by connecting credenzas to single pedestal desks or credenzas, desk or credenza shells, corners, extended corners or peninsulas.
- Adjustable hex leveling glides allow floor-standing furniture to be easily leveled without lifting the unit; glides have ¾" adjustable range.

HOW TO SPECIFY

Select
Model Number

H 1 0 5 4 1 3 .

Select
Laminate Top and Chassis Color

See pages 236-237

N N

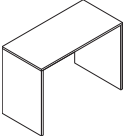
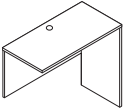

10500 SERIES™ Laminate Modular Components

	DESCRIPTION	INSIDE DIMENSIONS	MODEL	SHIP WEIGHT	CUBE	LIST PRICE BY LAMINATE GRADE	
						L1	L2
	Standing-Height Desk Shell						
	60"W x 30"D x 42"H	57½"W x 24½"D x 41⅝"H	H105397	185	6.2	\$837	\$877
	60"W x 24"D x 42"H	57½"W x 22¾"D x 41⅝"H	H105393	154	5.1	\$772	\$812
	48"W x 24"D x 42"H	45⅞"W x 22¾"D x 41⅝"H	H105392	143	4.2	\$722	\$757
	NOTES: Fixed height surface is 42"H. When combined with a stool-height task chair, provides users the benefit of alternating their work between a seated or standing position without the additional cost of an adjustable-height mechanism. Short, 22⅝" modesty panel provides over 18" of wall access; makes reaching wall electrical outlets quick and easy. Box/File Pedestal (H10501) attaches to the underside of the worksurface top to position supplies and files within easy reach.						
	Standing-Height Return Shell						
	48"W x 24"D x 42"H	47"W x 22¾"D x 41⅝"H	H105663	96	3.1	\$606	\$641
	NOTES: Non-handed design. Attaches to sit/stand desk shells to form an L-shaped workstation. Short, 22⅝" modesty panel makes reaching wall electrical outlets quick and easy. One cord management grommet in top for routing and hiding wires and cables. Grommet can be replaced with optional Power Hub (model HGRMTAC). Box/File Pedestal (H10501) attaches to the underside of the worksurface top to position supplies and files within easy reach.						

NOTES:

- 42"H shells help support a healthy work style by allowing users to switch between sitting and standing.
- Non-handed desk and return shells maximize office layout flexibility. Products can be reconfigured quickly and easily when user preferences or space needs change.
- Tops and end panels are abrasion- and stain-resistant laminate over durable 1⅝" solid core high-performance particleboard; resists warping.
- For additional components see pages 268-295.
- Mobile pedestals, shown on page 281, work well in a variety of applications and configurations.
- Adjustable hex leveling glides allow floor-standing furniture to be easily leveled without lifting the unit; glides have ¾" adjustable range.

HOW TO SPECIFY

Select Model Number H 1 0 5 3 9 7 .	Select Laminate Top and Chassis Color See pages 236-237 N N
---	--

10500 SERIES™

Laminate Modular Components

GSA SIN 33721



Icon Legend on page 19

Model H105686
shown

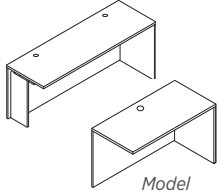

Model
H105686
shown

DESCRIPTION	INSIDE DIMENSIONS	MODEL	SHIP WEIGHT	CUBE	LIST PRICE BY LAMINATE GRADE	
					L1	L2
Return Shell (with full modesty panel)						
72"W x 24"D x 29½"H, (w/support; 2 grommets)	67"W x 22¾"D	H105686	145	5.4	\$696	\$736
60"W x 24"D x 29½"H, (w/support; 2 grommets)	55"W x 22¾"D	H105684	129	4.4	\$637	\$672
48"W x 24"D x 29½"H, (1 grommet)	47"W x 22¾"D	H10561	86	3.7	\$524	\$554
42"W x 24"D x 29½"H, (1 grommet)	41"W x 22¾"D	H105681	89	2.5	\$492	\$522
36"W x 24"D x 29½"H, (1 grommet)	34⅞"W x 22¾"D	H105680	83	3.2	\$492	\$517
30"W x 24"D x 29½"H, (1 grommet)	28⅞"W x 22¾"D	H10568	69	2.6	\$470	\$495

NOTES: Shells are non-handed. No pre-drilled grommet in modesty panel (field installable grommet included). Woodgrain direction on modesty/back panel runs vertical on 30"W-60"W sizes and horizontal on 72"W unit. 36"W return shell can be used to achieve a 6' x 6' L-shaped footprint when connected to either a 72"W x 36"D single pedestal desk, desk shell, or peninsula, or when two are connected to 36"W corner unit model H105811. 30"W return shell can be used to accomplish a 5' x 5' L-shaped footprint when connected to a 60"W x 30"D desk shell or peninsula. See pages 272-273 for optional stack-on storage.

⚠ Not designed to attach to corner units manufactured prior to 5/24/99.

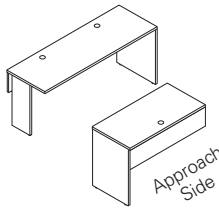

Return Shell (with 10"H modesty panel)						
72"W x 24"D x 29½"H, (w/support; 2 grommets)	67"W x 22¾"D	H105686X	106	4.6	\$696	\$736
60"W x 24"D x 29½"H, (w/support; 2 grommets)	55"W x 22¾"D	H105684X	93	3.9	\$637	\$672
48"W x 24"D x 29½"H, (1 grommet)	47"W x 22¾"D	H10561X	78	3.1	\$524	\$554
42"W x 24"D x 29½"H, (1 grommet)	41"W x 22¾"D	H105681X	69	3.8	\$492	\$522
36"W x 24"D x 29½"H, (1 grommet)	34⅞"W x 22¾"D	H105680X	67	3.8	\$492	\$517
30"W x 24"D x 29½"H, (1 grommet)	28⅞"W x 22¾"D	H10568X	56	2.6	\$470	\$495

NOTES: Makes reaching wall electrical outlets quick and easy. Provides more than 18" of clearance. See pages 272-273 for optional stack-on storage.

NOTES:

- Non-handed desk, credenza, and return shells, combined with a variety of under-the-worksurface storage solutions, maximize office layout flexibility. Products can be reconfigured quickly and easily when user preferences or space needs change.
- For additional components see pages 268-295.
- Tops and end panels are abrasion- and stain-resistant laminate over durable 1½" solid core high-performance particleboard; resists warping.
- Cord management grommets, for routing and hiding wires and cables, are located in the tops of desks and return shells.
- Adjustable hex leveling glides allow floor-standing furniture to be easily leveled without lifting the unit; glides have ¾" adjustable range.
- 36"W and 30"W return shells enable L-shaped layouts for smaller spaces.
- One cord management grommet in tops of Return Shell models, H10568 and H10568X, is used for routing and hiding wires and cables. The 3" round grommet can be replaced with optional Power Hub or Power/USB Hub — see page 294.

HOW TO SPECIFY

Select
Model Number

H 1 0 5 6 8 6 .

Select
Laminate Top and Chassis Color

See pages 236-237

N N



10500 SERIES™ Worksurfaces

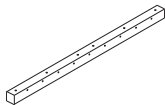
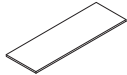
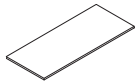

DESCRIPTION

Rectangle Worksurface

84"W x 30"D
78"W x 30"D
72"W x 30"D
66"W x 30"D
60"W x 30"D
48"W x 30"D

84"W x 24"D
78"W x 24"D
72"W x 24"D
66"W x 24"D
60"W x 24"D
48"W x 24"D
42"W x 24"D
36"W x 24"D
30"W x 24"D

NOTES: Underside of rectangle worksurfaces includes pilot mounting holes for end panels, support columns, post legs, H-legs, and O-legs, and height adjustable base. Applications for 24"D worksurfaces include desks, credenzas, returns, and bridges. For Above Privacy Screen sizes, see page 203.

Bullet Worksurface

72"W x 30"D
66"W x 30"D
60"W x 30"D

60"W x 24"D

NOTES: Applications include use as a peninsula in a U- or L-shaped workstation or as an island extension. One flat bracket (mounting plate) ships with each worksurface for applications requiring connection to an adjoining worksurface. Underside includes pilot mounting holes for T- and L-shaped end panels, H-leg, O-leg, support column, post leg, or flat bracket. Grain direction runs horizontal.

ⓘ When specifying 60"W Floating Modesty Panel, it is not necessary to specify an external channel.

DESCRIPTION

External Support Channel

42"W for a 54" Worksurface
48"W for a 60" Worksurface
54"W for a 66" Worksurface
60"W for a 72" Worksurface
72"W for an 84" Worksurface

ⓘ Available in Graphite paint only.

ⓘ When specifying panel-hung worksurfaces, specify external channel as if supported by two H-legs or O-legs via selection chart.

ⓘ When specifying a 54"W or 60"W Floating Modesty Panel, it is not necessary to specify an external channel.

MODEL	SHIP WEIGHT	CUBE	LIST PRICE BY LAMINATE GRADE	
			L1	L2
H105R3084	88	6.5	\$475	\$500
H105R3078	81	6.1	\$429	\$454
H105R3072	83	6.1	\$402	\$422
H105R3066	76	6.1	\$374	\$394
H105R3060	69	5.2	\$349	\$369
H105R3048	55	4.1	\$286	\$301
H105R2484	70	5.3	\$437	\$462
H105R2478	65	4.9	\$389	\$409
H105R2472	66	4.9	\$342	\$362
H105R2466	61	4.9	\$331	\$351
H105R2460	55	4.2	\$311	\$331
H105R2448	44	3.4	\$264	\$279
H105R2442	39	3.0	\$239	\$254
H105R2436	30	2.4	\$207	\$222
H105R2430	25	2.0	\$207	\$222

MODEL	SHIP WEIGHT	CUBE	L1	L2
H105B3072	79	6.1	\$417	\$437
H105B3066	73	6.1	\$394	\$414
H105B3060	66	5.2	\$376	\$396
H105B2460	45	4.2	\$322	\$337

MODEL	SHIP WEIGHT	CUBE	LIST PRICE
HLSLZ5SC54 ⓘ	5	0.5	\$93
HLSLZ5SC60	6	0.5	\$98
HLSLZ5SC66	7	0.5	\$101
HLSLZ5SC72	7	0.5	\$110
HLSLZ5SC84	12	0.7	\$110

NOTES:

- Easy-care, scratch-, spill- and stain-resistant laminate over 1/8" solid core high-performance particleboard.
- Grain direction on all worksurfaces runs horizontal.
- One flat bracket (mounting plate) ships with each worksurface for applications requiring connection to an adjoining worksurface.
- For standing-height requirements, use worksurface with 41"H laminate L-shaped end panel or metal O-leg.
- For 30", 36", 42" and 48"W x 24"D mobile desks and tables, use post leg with casters model HMBPOST.C.
- For end panels, legs, columns and bases, see the Worksurface Supports listing on pages 250-251.
- When using a floating modesty panel or an external channel under the worksurface, the depth clearance for keyboard trays and center drawers decreases by 8". See accessory matrix in accessory section of the pricer.

- ⓘ 84"W worksurfaces are for 29 1/2"H applications only (not 42"H) and require a T-support brace or other weight-bearing floor support to be positioned between the O-legs or L-shaped end panels.
- ⓘ Worksurfaces are subject to slight bowing. The magnitude of the deflection is dependent upon the weight, placement, and duration of the load.
- ⓘ When using a worksurface as a bridge, no additional supports are needed. One support is required for returns, two supports are required for desks and credenzas.
- ⓘ External channel support is recommended for extended unsupported spans or heavily loaded worksurfaces. See above for details.

EXTERNAL SUPPORT CHANNEL (Model HLSLZ5SCxx) — RECOMMENDED USE							
	Support Combination		Rectangle Worksurface Width				
	Support 1	Support 2	60"	66"	72"	78"	84"
O-Leg	O-Leg	O-Leg	66	72	78	84	NA
	O-Leg	4 1/2" Dia. Support Column	NR	60	66	72	78
	O-Leg	2" Square Post Leg	NR	60	66	72	78
L-Shaped End Panel	L End Panel	L End Panel	NR	60	66	72	78
	L End Panel	O-Leg	60	66	72	78	84
	L End Panel	4 1/2" Dia. Support Column	NR	60	66	72	78
	L End Panel	2" Square Post Leg	NR	60	66	72	78
T-Shaped End Panel	T End Panel	O-Leg	60	66	72	78	84
	T End Panel	4 1/2" Dia. Support Column	NR	60	66	72	78
	T End Panel	2" Square Post Leg	NR	60	66	72	78
Return Config End Panel	None	O-Leg	66	72	78	84	NA
	None	L End Panel	60	66	72	78	84

HOW TO SPECIFY

<p>Select Model Number</p> <p>H 1 0 5 R 3 0 7 2</p>	<p>Select Worksurface Laminate and Edge Color</p> <p>See pages 236-237</p> <p>N N</p>
--	--

10500 SERIES™

Worksurface Supports

GSA SIN 33721



Icon Legend on page 19

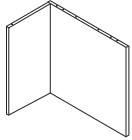

Not available in
two-tone laminate

DESCRIPTION**L-shaped End Panel**

15 $\frac{3}{4}$ "W x 29 $\frac{7}{8}$ "D x 28 $\frac{1}{2}$ "H
15 $\frac{3}{4}$ "W x 23 $\frac{7}{8}$ "D x 28 $\frac{1}{2}$ "H
15 $\frac{3}{4}$ "W x 29 $\frac{7}{8}$ "D x 41"H
15 $\frac{3}{4}$ "W x 23 $\frac{7}{8}$ "D x 41"H

MODEL**SHIP WEIGHT****CUBE****LIST PRICE BY LAMINATE GRADE****L1****L2**

H10530LEP	49	4.1	\$288	\$300
H10524LEP	43	3.7	\$270	\$282
H1053041LEP	68	4.2	\$364	\$384
H1052441LEP	60	3.4	\$329	\$349

NOTES: Non-handed. 29 $\frac{7}{8}$ "D for use with 48"-78"W x 30"D worksurfaces; 23 $\frac{7}{8}$ "D for use with 30"-78"W x 24"D worksurfaces. Not for use with 84"W unless additional floor supports are placed between the end panels. Design facilitates easy, open access to wall electrical outlets. Adjustable hex glides allow floor-standing units to be easily leveled without lifting to compensate for uneven floors. Glides have $\frac{3}{4}$ " adjustable range. Two pieces; 1 $\frac{1}{8}$ " end panel and $\frac{3}{4}$ " back panel. 10500 Series™ modular and mobile pedestals fit flush to the end panel. Simple assembly.

⚠ Not designed to be used freestanding.

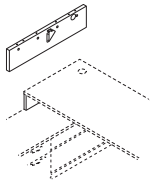

HNLEP307L shown

Laminate End Panel — 7"H Support for Worksurfaces

1 $\frac{1}{8}$ "W x 30"D x 7"H, Right
1 $\frac{1}{8}$ "W x 30"D x 7"H, Left
1 $\frac{1}{8}$ "W x 24"D x 7"H, Right
1 $\frac{1}{8}$ "W x 24"D x 7"H, Left

HNLEP307R

7

0.7

\$136**\$10****HNLEP307L**

7

0.7

\$136**\$10****HNLEP247R**

6

0.7

\$136**\$10****HNLEP247L**

6

0.7

\$136**\$10**

NOTES: Specifically for layered surface applications; used to support a 29 $\frac{1}{2}$ "H component worksurface over a 21 $\frac{1}{2}$ "H low credenza unit. 1 $\frac{1}{8}$ " thick. Handed design (left and right models). Includes cord routing notch. Bottom of end panel is edgedbanded for added strength and to seal out moisture. Attaches to underside of worksurface via cam fasteners and L-bracket; attaches to top of low credenza with double-sided tape. Can be specified in a woodgrain or solid laminate color only. For 7"H metal O-leg support see page 94.

SPECIFYING EXAMPLE: HNLEP307R.H

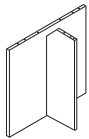

Not available in
two-tone laminate

T-shaped End Panel

11 $\frac{5}{8}$ "W x 29 $\frac{7}{8}$ "D x 28 $\frac{1}{2}$ "H
11 $\frac{5}{8}$ "W x 23 $\frac{7}{8}$ "D x 28 $\frac{1}{2}$ "H

H10530TEP

45

3.7

\$265**\$277****H10524TEP**

38

3.2

\$248**\$260**

NOTES: Non-handed. For use with 30"D and 24"D 10500 Series worksurfaces. Two 1 $\frac{1}{8}$ " thick pieces; one end and one brace panel. Cord routing notch in brace panel. Simple assembly.

⚠ Not designed to be used freestanding.

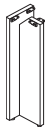

Not available in
two-tone laminate

T-Support Brace

8"W x 23 $\frac{3}{4}$ "D x 28 $\frac{1}{2}$ "H

H10524TSUPP

14

0.8

\$224**\$239**

NOTES: Intermediate support option for 29 $\frac{1}{2}$ "H workstations. Designed for 24"D and 30"D worksurfaces without a modesty or back panel, with an unsupported span greater than 48"W. Can be used to support the junction of two 24"D adjoining linear worksurfaces. Adjustable hex glides allow floor-standing units to be easily leveled without lifting to compensate for uneven floors; glides have $\frac{3}{4}$ " adjustable range. Simple assembly.

NOTES:

- Adjustable hex leveling glides allow floor-standing furniture to be easily leveled without lifting the unit; glides have $\frac{3}{4}$ " adjustable range.

⚠ Laminate L- and T-shaped end panels can be specified as one color only; not available in two-tone laminate combination or in a pattern laminate.

HOW TO SPECIFY

Select
Model Number

Select
Laminate

See pages 236-237

H 1 0 5 3 0 T E P . N



10500 SERIES™ Worksurface Supports

**DESCRIPTION****Support Column for 10500 Series Rectangle and Bullet Worksurfaces**

3" Diameter
For **Black**, specify HPC190X.P.
For **Silver**, specify HPC191X.X.

MODEL SHIP WEIGHT CUBE LIST PRICE

HPC190X	12 Ⓞ	1.0	\$161
HPC191X	12 Ⓞ	1.0	\$161

NOTES: Can only be used as the outbound support in a peninsula or island extension worksurface application. Glides have 3/4" adjustable range.

! Support column must be specified for worksurfaces used as peninsulas or as an island extension.

**DESCRIPTION**

Post Leg Base
28 1/2" H x 2" square

MODEL	SHIP WEIGHT	CUBE	LIST PRICE BY PAINT GRADE		
			P1	P2	P3

HLSL28P	15	1.0	\$298	\$302	\$318
----------------	----	-----	--------------	--------------	--------------

NOTES: Can only be used as the outbound support in a peninsula or island extension worksurface application. Glides have 2" of adjustability. Ship 1/pack.

! Post leg can only be used to support peninsula, not as primary supports for a top.

SPECIFYING EXAMPLE: HLSL28P.T1

24" D Rectangle Worksurface Support Options

Product Application	Support Combination		Support Model Numbers for 72" W, 66" W, or 60" W Worksurfaces	Support Model Numbers for 48" W or 42" W Worksurfaces
	Support 1	Support 2		
Desk or Credenza	O-Leg	O-Leg	HLSL24280 (2)	HLSL24280 (2)
	O-Leg	L-Shaped End Panel	HLSL24280 / H10524LEP	HLSL24280 / H10524LEP
	L-Shaped End Panel	L-Shaped End Panel	H10524LEP (2)	H10524LEP (2)
	T-Shaped End Panel	O-Leg	H10524TEP / HLSL24280	H10524TEP / HLSL24280
	T-Shaped End Panel	L-Shaped End Panel	H10524TEP / H10524LEP	H10524TEP / H10524LEP
Peninsula for U- or L-Configuration; Not Freestanding	O-Leg	3" Diameter Support Column	HLSL24280 / HPC190X-191X	NA
	O-Leg	2" Square Post Leg	HLSL24280 / HLSL28P	NA
	L-Shaped End Panel	3" Diameter Support Column	H10524LEP / HPC190X-191X	NA
	L-Shaped End Panel	2" Square Post Leg	H10524LEP / HLSL28P	NA
	T-Shaped End Panel	3" Diameter Support Column	H10524TEP / HPC190X-191X	NA
	T-Shaped End Panel	2" Square Post Leg	H10524TEP / HLSL28P	NA
Desk, Credenza, or Freestanding Return or Bridge	Adjustable Height Base - Electric		HHAB3S2L	HHAB3S2L (48" W min.)
Return (requires one support)	O-Leg	—	HLSL24280	HLSL24280
	L-Shaped End Panel	—	H10524LEP	H10524LEP
	T-Shaped End Panel	—	H10524TEP	H10524TEP
	3" Diameter Support Column	—	HPC190X or HPC191X	HPC190X or HPC191X
	2" Square Post Leg	—	HLSL28P	HLSL28P
Island Extension (requires one support)	O-Leg	—	HLSL24280	HLSL24280
	3" Diameter Support Column	—	HPC190X or HPC191X	HPC190X or HPC191X
	2" Square Post Leg	—	HLSL28P	HLSL28P

72" W, 66" W, or 60" W x 30" D Bullet Worksurface Support Options

Product Application	Support Combination		Support Model Numbers
	Support 1	Support 2	
Peninsula for U- or L-Configuration; Not Freestanding	O-Leg	3" Diameter Support Column	HLSL30280 / HPC190X or HPC191X
	O-Leg	2" Square Post Leg	HLSL30280 / HLSL28P
	L-Shaped End Panel	3" Diameter Support Column	H10530LEP / HPC190X or HPC191X
	L-Shaped End Panel	2" Square Post Leg	H10530LEP / HLSL28P
	T-Shaped End Panel	3" Diameter Support Column	H10530TEP / HPC190X or HPC191X
	T-Shaped End Panel	2" Square Post Leg	H10530TEP / HLSL28P
Island Extension	3" Diameter Support Column	—	HPC190X or HPC191X
	2" Square Post Leg	—	HLSL28P

HOW TO SPECIFY

Select
Model Number

H P C 1 9 0 X .

Select
Paint Color

See page 173

T 1

10500 SERIES™

Worksurface Supports

OPEN MARKET



Icon Legend on page 19

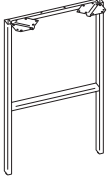

DESCRIPTION	MODEL	SHIP WEIGHT	CUBE	LIST PRICE BY PAINT GRADE		
				P1	P2	P3
H-Leg Support for Worksurfaces 30"W x 28 ³ / ₈ "H 24"W x 28 ³ / ₈ "H	H105HLEG3028	13.6	5.1	\$352	\$356	\$372
	H105HLEG2428	12.5	3.7	\$316	\$320	\$336
Standing-Height H-Leg Support for Worksurfaces 30"W x 41"H 24"W x 41"H	H105HLEG3041	16.5	6.5	\$474	\$482	\$494
	H105HLEG2441	15.4	5.3	\$424	\$432	\$444

NOTES:

- Legs ship fully assembled with mounting hardware, 1 per pack. Non-handed. H-leg glides have 2" adjustability. Will have 6" overhang when using 30"D H-legs with a 36"D worksurface.

! The H-leg attachment bracket interferes with placement of 10500 Series™ modular pedestals and 28³/₈"H mobile pedestals, preventing them from being positioned directly next to (flush with) the H-leg. Box/File mobile pedestal model H105106 and mobile printer/fax cart model H105679 can be positioned along side the H-leg.

! O- and H-legs may only be attached to worksurfaces, not storage units.

HOW TO SPECIFY

Select Model Number









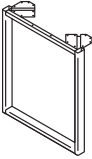

Select Paint Color

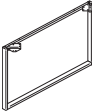
See page 173

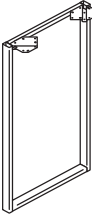
H105HLEG2441.

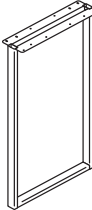
T1

10500 SERIES™ Worksurface Supports

	DESCRIPTION	MODEL	SHIP WEIGHT	CUBE	LIST PRICE BY PAINT GRADE		
					P1	P2	P3
  	O-Leg 30"D x 28½"H 24"D x 28½"H	HLSL30280 ☉ HLSL24280	19.0 17.0	5.4 3.7	\$359 \$324	\$363 \$328	\$379 \$344
	<p>NOTES: Ship fully assembled with mounting hardware, 1/pack. Non-handed. O-leg glides have 2" adjustability. Shared O-legs create a cleaner aesthetic in all applications where two legs are used side-by-side. Will have 6" overhang when using 30"D O-legs with a 36"D worksurface.</p> <p>IMPORTANT: The O-leg attachment bracket interferes with placement of 10500 Series modular pedestals and 28¾"H mobile pedestals, preventing them from being positioned directly next to (flush with) the O-leg. Box/file mobile pedestal (model H105106) and mobile printer/fax cart model (H105679) can be positioned along side the O-leg.</p> <p>! O-legs may only be attached to worksurfaces, not storage units. SPECIFYING EXAMPLE: HLSL24280.T1</p>						
  	Double-Depth O-Leg Support for Worksurfaces 60"D x 28½"H 48"D x 28½"H	HLSL60280 HLSL48280	19.0 18.0	8.7 7.0	\$679 \$610	\$687 \$618	\$699 \$630
	<p>NOTES: Ship fully assembled with mounting hardware, 1/package. Non-handed. 48"D and 60"D sizes span back-to-back 24"D and 30"D worksurfaces, respectively. O-leg glides have 2" adjustability. Shared O-legs create a cleaner aesthetic in all applications where two legs are used side-by-side. Will have 6" overhang when using 30"D O-legs with a 36"D worksurface.</p> <p>! O-legs may only be attached to worksurfaces, not storage units.</p>						
  	Standing-Height O-Leg Support for Worksurfaces 30"D x 41"H 24"D x 41"H	HLSL30410 HLSL24410	17.0 16.0	6.5 5.3	\$485 \$433	\$491 \$439	\$505 \$453
	<p>NOTES: Ship fully assembled with mounting hardware, 1/package. Non-handed. O-leg glides have 2" adjustability. O-leg installation requires 6" of clearance from the worksurface end. Shared O-legs create a cleaner aesthetic in all applications where two legs are used side-by-side. Will have 6" overhang when using 30"D O-legs with a 36"D worksurface.</p> <p>Coordinate™ Power Modules will work with standing-height applications for 10500™ and Voi® desks.</p> <p>! O-legs may only be attached to worksurfaces, not storage units.</p>						
  	Standing-Height O-Leg Shared Support for Worksurfaces 30"D x 41"H 24"D x 41"H	HLSL3041SL HLSL2441SL	17.0 16.0	6.5 5.3	\$540 \$488	\$546 \$494	\$560 \$508
	<p>NOTES: Ship fully assembled with mounting hardware, 1/package. Non-handed. For use with two 24"D or 30"D worksurfaces positioned side-by-side along the depth dimension. O-leg glides have 2" adjustability. O-leg installation requires 6" of clearance from the worksurface end. Shared O-legs create a cleaner aesthetic in all applications where two legs are used side-by-side. Will have 6" overhang when using 30"D O-legs with a 36"D worksurface.</p> <p>Coordinate™ Power Modules will work with standing-height applications for 10500™ and Voi® desks. Please see Coordinate™ Accessories Stand-Alone Pricer pages for more information.</p> <p>! O-legs may only be attached to worksurfaces, not storage units.</p>						
 OPEN MARKET	O-Leg Cord Clips Clips for 28½" Worksurface O-Legs — 8-Pack	HWMCLIPG	0.8 ☉	0.1	\$99	N/A	N/A
	<p>NOTES: Wire clips work with 7" Low Credenza O-leg and 29"H Support O-leg. Wire clips also work with the 50" and 65" Hutch O-legs. For additional information see the Workplace Tools section in the 2021 Shared Spaces Pricer.</p> <p>! Available in frosted plastic material only.</p>						

NOTES:

! For shared components such as modesty panels and Privacy Screens see pages 201-203.

HOW TO SPECIFY

Select Model Number	Select Paint Color
See page 173	See page 173
H L S L 3 0 2 8 0	T 1

10500 SERIES™

Worksurface Supports

GSA SIN 33721 EXCEPT AS NOTED

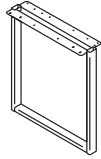

Icon Legend on page 19

**DESCRIPTION****O-Leg Shared Support for Worksurfaces**

30"D x 28½"H
24"D x 28½"H

MODEL

HLSL3028SL ⓘ
HLSL2428SL

SHIP WEIGHT**CUBE****LIST PRICE BY PAINT GRADE**

P1	P2	P3
\$447	\$451	\$467
\$402	\$406	\$422

NOTES: Ship fully assembled, 1/pack. Non-handed.

ⓘ Specify paint only.

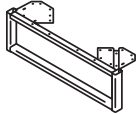
SPECIFYING EXAMPLE: HLSL2028SL.T1**O-Leg Support for Low Credenzas**

30"D x 7"H
24"D x 7"H

HLSL3070 ⓘ
HLSL2470

7
6

1.0
1.0

P1	P2	P3
\$277	\$281	\$297
\$218	\$222	\$238

NOTES: Ship fully assembled, 1/pack. Non-handed. For 7"H laminate support see page 92.

ⓘ Specify paint only.

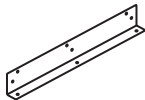
SPECIFYING EXAMPLE: HLSL2070.T1

HVPWLBK24 shown

OPEN MARKET**DESCRIPTION****Worksurface Wall Mount Bracket**

For 30"
For 24"

MODEL

HVPWLBK30
HVPWLBK24

SHIP WEIGHT**CUBE****LIST PRICE**

2	0.3	\$91
2	0.3	\$83

NOTES: Can be used in place of an end panel or O-leg to support a worksurface. Cannot be used as a support when placing a stack-on storage unit on worksurface over bracket; must have two full-sized floor supports when using stack-on storage. Finish option not required.

SPECIFYING EXAMPLE: HVPWLBK30**DESCRIPTION****Worksurface to Tower Bracket Kit**

18½" long bracket for attaching 24"D worksurface directly to storage tower, wardrobe/bookcase, wardrobe/storage cabinet, storage cabinet/lateral file, storage cabinet, or lateral file.

MODEL**HSTB2W1****SHIP WEIGHT****CUBE****LIST PRICE BY PAINT GRADE**

P1	P2	P3
\$79	\$92	\$94

NOTES: Can be used in place of end panel or O-leg to support worksurfaces.

ⓘ Bracket not designed for use as a support if placing Stack-on Storage on worksurface over/above bracket. Two full-sized supports required when using Stack-on Storage.

NOTES:

- O-leg glides have 2" adjustability.
- For shared components such as modesty panels and Privacy Screens see pages 201-203.
- O-leg ships fully assembled with mounting hardware.
- For standing-height O-leg sizes, see page 253.
- Shared O-legs create a cleaner aesthetic in all applications where two legs are used side-by-side.
- Will have 6" overhang when using 30"D O-legs with a 36"D worksurface.

ⓘ O-legs may only be attached to worksurfaces, not storage units.

ⓘ O-leg installation requires 6" of clearance from the worksurface end.

HOW TO SPECIFY

Select Model Number	Select Paint Color
	See page 173
HVPWLBK30	T1

10500 SERIES™

Components — Supports

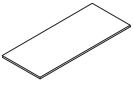
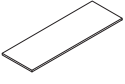
	DESCRIPTION	MODEL	SHIP WEIGHT	CUBE	LIST PRICE BY LAMINATE GRADE	
					L1	L2
	Rectangle Worksurface					
	72"W x 30"D	H105R3072	83	6.1	\$402	\$422
	66"W x 30"D	H105R3066	76	6.1	\$374	\$394
	60"W x 30"D	H105R3060	69	5.2	\$349	\$369
	48"W x 30"D	H105R3048	55	4.1	\$286	\$301
	72"W x 24"D	H105R2472	66	4.9	\$342	\$362
	66"W x 24"D	H105R2466	61	4.9	\$331	\$351
	60"W x 24"D	H105R2460	55	4.2	\$311	\$331
	48"W x 24"D	H105R2448	44	3.4	\$264	\$279
	42"W x 24"D	H105R2442	39	3.0	\$239	\$254

NOTES: Underside of rectangle worksurfaces includes pilot mounting holes for end panels, support columns, post and O-legs, and height adjustable base. Applications for 24"D worksurfaces include desks, credenzas, returns, and bridges. The 42"W x 24"D size is not compatible with Height Adjustable Base model HHAB3S2L; it can however, be used in combination with the 72"W x 30"D work surface on 3-Leg Height Adjustable Base model HHAB3S3L. For Above Privacy Screen sizes, see page 203.

NOTES:

- Height Adjustable Base is a 3-stage column design.
 - Frame rises from 21 $\frac{5}{8}$ " to 47 $\frac{3}{4}$ " for a sit-to-stand desk option.
 - Height Adjustable Bases shipped complete with a pre-assembled motor.
 - Base telescopes to accommodate any work surface between 48"W and 72"W.
 - Height Adjustable Base accommodates rectangular worksurfaces between 24"D x 48"W and 30"D x 72"W. Systems, Voi®, 10500, and Preside® all have worksurfaces within this range.
 - Comes standard with one-touch, four memory controller with digital display; no specification needed, available in black finish only.
 - Standard height adjustable control ships with base.
 - Dynamic load capacity when work surface is moving is 250 lbs.
- ⓘ Worksurfaces used with Coordinate™ Height Adjustable Bases should have 1" perimeter gap on each side to provide clearance between other furniture. Failure to do so risks injury or product damage (not covered by warranty).

HOW TO SPECIFY

Select Model Number <input type="text" value="H105R3072"/>	Select Laminate <input type="text" value="NN"/> See pages 236-237
--	--

10500 SERIES™ Height Adjustable Bases

GSA SIN AS NOTED



Icon Legend on page 19

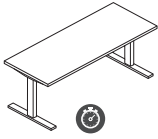

Base shown with work surface attached.

OPEN MARKET

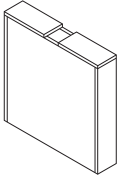

Not available in two-tone laminate.

SIN 33721

DESCRIPTION

Coordinate™ Height Adjustable Base – 3 Stage
24”D Feet and Worksurface Brackets

MODEL

HHAB3S2L

SHIP WEIGHT

67.0

CUBE

2.4

LIST PRICE

\$1120

NOTES: Base is a dual motor 3-stage design with standard anti-collision. Legs raise from 21⁵/₈” to 47³/₄”. Base telescopes to accommodate any rectangular work surface between 24”D x 42”W and 30”D x 72”W. Supports weight capacity of 250 lbs. (excluding work surface weight). Concinnity™, Systems, Voi®, 10500, and Preside® all have work surfaces within this range. Comes standard with one-touch, four memory controller with digital display; no specification needed, available in black finish only. UL Certified. **HON 7-Year Limited Warranty.**

- ⓘ Telescoping horizontal frame will extend just over 2” from underside of the work surface.
- ⓘ Removal of stretcher bars in Coordinate™ base is required when pairing with a 42”W work surface.

Shroud for Height Adjustable Base

5¹/₈”W x 26”D x 26¹/₄”H for Base with 30”D Top

HLAMSHB30

39.0

3.7

\$848

NOTES: Decorative laminate enclosure covers the Coordinate™ metal leg and foot. Lowest base adjustment position when the shroud is installed is 29¹/₂”H; memory controller must be set at that height to avoid interference. For use with standard 10500 Series™, Concinnity™, and Voi® rectangle work surfaces, 48-72”W x 30”D, supported by Height Adjustable Base models HHAB3S2L or HHAB2S2L. For height adjustable desks requiring a modesty panel, options include: 14”H laminate (HLSLXX14L) or mixed material (HLSLXX14MM) floating modesty panels, laminate full length (HNLMPXX28) or short (HNLMPXX10) modesty/back panel plus external support channel (HLSLZ5SCXX). External support channel attachment screws and modesty/back panel cover caps are included in the shroud hardware pack. External support channel size recommendation, specific to work surface attached to Height Adjustable Base with optional laminate full-length or short modesty back/panel (HNLMPXX28/10) see below. Ships one per carton. To conceal both metal legs on the Height Adjustable Base order two. **When using a modesty panel set height adjustable table at 29”H to ensure table stops before hitting shroud.** Specify: Model.Laminate; see pages 236-237.

SPECIFYING EXAMPLE: HLAMSHB30.N

- ⓘ The Height Adjustable Base must be reset at the time of installation, after every loss of power, if the unit is not functioning properly, or if the legs are uneven. To reset the base requires removing the laminate shroud(s), as well as the full-length modesty panel if one is being used, then adjusting the base to its lowest position. Disassembly of the shroud is quick and easy.
- ⓘ \$25 upcharge for L2 laminates.

Worksurface Width	Modesty/Back Panel Width	External Support Channel
72”W	72”W	HLSLZ5SC78
66”W	66”W	HLSLZ5SC72
60”W	60”W	HLSLZ5SC66
54”W	54”W	HLSLZ5SC60
48”W	48”W	HLSLZ5SC54

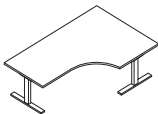

Base shown with work surface attached.

OPEN MARKET

Coordinate™ 3-Leg Height Adjustable Base – 3 Stage

24”D Feet and Worksurface Brackets

HHAB3S3L

91.0

3.6

\$1896

NOTES: Base is a three motor 3-stage design with standard anti-collision. Legs raise from 21⁵/₈” to 47³/₄”. The 3-leg base supports corner covers or two-piece work surfaces 41”-72”W x 35”-72”L x 23¹/₄”-30”D. 48”W 120 degree corner work surfaces are also supported. When using two work surfaces, the connection between the two must be over the telescoping frame. Supports weight capacity of 375 lbs. (excluding work surface weight). Can be used with 48” 120 degree and work surface models. Comes standard with one-touch, four memory controller with digital display; no specification needed, available in black finish only. UL Certified. **HON 5-Year Limited Warranty.**

- ⓘ When using two work surfaces, a flat bracket is required. Bracket purchased separately — HHN831124, HHN831130 — see page 606.
- ⓘ Telescoping horizontal frame will extend just over 2” from underside of the work surface.



SIN 33721

Under Worksurface Power Module – 4 Outlets, 10’ Cord

- Includes 10’ cord with three-prong plug.
- Fits in cable management troughs. See page 233.
- 4 outlets on side create easy access.

HPWRMOD2

1.5

0.2

\$401

NOTES: Power Modules will also work with standing-height applications for 10500 Series™ and Voi® desks. For additional information see the Workplace Tools section in the 2021 Shared Spaces Pricer.

- ⓘ Available in black finish only, no specification needed.

NOTES:

- ⓘ Coordinate™ Height Adjustable Bases not compatible with 36”D rectangular work surfaces.

HOW TO SPECIFY

<p>Select Model Number</p> <p>HHAB3S2L .</p>	<p>Select Finish</p> <p>P71 Black P8L Nickel PD8 White</p> <p>P8L</p>
---	--



10500 SERIES™ Shared Components

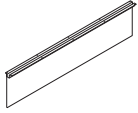

DESCRIPTION	MODEL	SHIP WEIGHT	CUBE	LIST PRICE BY LAMINATE GRADE	
				L1	L2
Laminate Floating Modesty Panel					
60"W x 14"H	HLSL6014L	20	1.1	\$253	\$265
54"W x 14"H	HLSL5414L	18	1.1	\$235	\$247
48"W x 14"H	HLSL4814L	16	1.1	\$215	\$227
42"W x 14"H	HLSL4214L	14	0.8	\$195	\$205
36"W x 14"H	HLSL3614L	12	0.8	\$183	\$193
30"W x 14"H	HLSL3014L	10	0.8	\$173	\$183

NOTES: The attachment bracket and modesty panel are packaged separately.

Specify: Model.Laminate.Paint

SPECIFYING EXAMPLE: HLSL3014L.N.P (Black is the only paint option for this model)

ⓘ When specifying the 54"W or 60"W Laminate Floating Modesty Panel, it is not necessary to specify an external channel.

ⓘ 30"W and 36"W screens attach with L-brackets, not the external channel.

NOTES:

- Laminate or mixed material floating modesty panels options are available for attachment under 10500 Series worksurfaces. The modesty panel and attachment bracket are packaged separately.
- If using a 54"W or 60"W floating modesty panel, it is not necessary to specify an external support channel under the worksurface.
- When using a floating modesty panel under the worksurface, the depth clearance for center drawers and keyboard platforms decreases by 8".

FLOATING MODESTY PANELS - MODEL SELECTION GUIDE						
Support Combination		Rectangle Worksurface Width				
Support 1	Support 2	72 in	66 in	60 in	48 in	42 in
O-Leg	O-Leg	HLSL6014	HLSL5414	HLSL4814	HLSL3614	HLSL3014
O-Leg	L-Shaped End Panel	HLSL4814	HLSL4214	HLSL3614	NA	NA
O-Leg	4½" Diameter Support Column	HLSL4814	HLSL4814	HLSL4814	HLSL3614	HLSL3014
O-Leg	2" Square Post Leg	HLSL4814	HLSL4814	HLSL4814	HLSL3614	HLSL3014
L-Shaped End Panel	L-Shaped End Panel	HLSL3614	HLSL3014	NA	NA	NA
L-Shaped End Panel	4½" Diameter Support Column	HLSL3614	HLSL3614	HLSL3614	NA	NA
L-Shaped End Panel	2" Square Post Leg	HLSL3614	HLSL3614	HLSL3614	NA	NA
T-Shaped End Panel	O-Leg	HLSL5414	HLSL4814	HLSL4214	HLSL3014	NA
T-Shaped End Panel	L-Shaped End Panel	HLSL3614	HLSL3014	NA	NA	NA
T-Shaped End Panel	4½" Diameter Support Column	HLSL3614	HLSL3014	NA	NA	NA
T-Shaped End Panel	2" Square Post Leg	HLSL3614	HLSL3014	NA	NA	NA

Support Combination		Bullet Worksurface Width		
Support 1	Support 2	72 in	66 in	60 in
O-Leg	4½" Diameter Support Column	HLSL4814	HLSL4814	HLSL4814
O-Leg	2" Square Post Leg	HLSL4814	HLSL4814	HLSL4814
L-Shaped End Panel	4½" Diameter Support Column	HLSL3614	HLSL3614	HLSL3614
L-Shaped End Panel	2" Square Post Leg	HLSL3614	HLSL3614	HLSL3614
T-Shaped End Panel	4½" Diameter Support Column	HLSL3614	HLSL3614	HLSL3614
T-Shaped End Panel	2" Square Post Leg	HLSL3614	HLSL3614	HLSL3614

HOW TO SPECIFY

Select Model Number

HLSL3014L

Select Laminate

See pages 236-237

N

10500 SERIES™

Shared Components

GSA SIN 33721

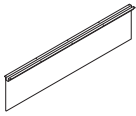

Icon Legend on page 19

**DESCRIPTION****Mixed Material Floating Modesty Panel**

60"W x 14"H
54"W x 14"H
48"W x 14"H
42"W x 14"H
36"W x 14"H
30"W x 14"H

MODEL

HLSL6014MM ☉
HLSL5414MM ☉
HLSL4814MM ☉
HLSL4214MM ☉
HLSL3614MM
HLSL3014MM

SHIP WEIGHT

13
13
11
9
8
8

CUBE

3.3
3.3
2.6
2.3
2.0
2.0

LIST PRICE

\$1134
\$992
\$914
\$826
\$739
\$689

NOTES: The attachment bracket and modesty panel are packaged separately. Laminate or mixed material floating modesty panels options are available for attachment under 10500 Series worksurfaces. The modesty panel and attachment bracket are packaged separately. If using a 54"W or 60"W floating modesty panel, it is not necessary to specify an external support channel under the worksurface. When using a floating modesty panel under the worksurface, the depth clearance for center drawers and keyboard platforms decreases by 8". See charts on previous page.

Specify: Model.Mixed Material.Paint

SPECIFYING EXAMPLE: HLSL3014MM.FT01.P (Frosted Translucent mixed material and Black paint are the only options for this model)

⚠ When specifying the 54"W or 60"W Mixed Material Floating Modesty Panel, it is not necessary to specify an external channel.

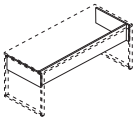

Not available in
two-tone laminate

Modesty Panels for Desks with O-Legs

68³/₈"W x 3¹/₄"D x 10"H — For 72" x 30" Desks
56³/₈"W x 3¹/₄"D x 10"H — For 60" x 30" Desks

HLAMMP7230
HLAMMP6030

26
23

2.1
1.8

\$289
\$264

NOTES: For use with 60"W or 72"W worksurfaces supported by O-legs. Comprised of three panels: one approach side and one for each end. Length below bottom of worksurface is 10". Steel external support channel (ordered separately) is recommended for unsupported spans greater than 54"W (i.e.: a distance in which there is not a vertical support between the underside of the worksurface and floor). Grain direction is vertical on approach and side panels for 56³/₈"W (all laminate colors) and 68³/₈"W (L1 laminate except Florence Walnut and Kingswood Walnut). Vertical on 27⁵/₈" end panels (all laminate colors). Horizontal on all panels for L2 laminates as well as Florence Walnut and Kingswood Walnut.

Specify: Model.Laminate

SPECIFYING EXAMPLE: HLAMMP7230.N

⚠ \$15 upcharge for L2 laminates. See pages 236-237 for laminate options.

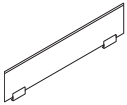
**Above Privacy Screen**

60"W x 13"H
54"W x 13"H
48"W x 13"H
42"W x 13"H
36"W x 13"H
30"W x 13"H

HLSL1260
HLSL1254
HLSL1248
HLSL1242
HLSL1236
HLSL1230

24
22
20
18
15
13

2.9
2.9
2.3
2.3
1.8
1.5

\$462
\$430
\$402
\$352
\$314
\$285

NOTES: Ships complete with attachment bracket. Bracket is Platinum only, no need to specify. Attaches to top of rectangle worksurfaces; requires a minimum overhang of 1¹/₂".

⚠ Available in Frosted Glass ONLY HLSL1230.G.

⚠ Above only Privacy Screen clamps onto worksurface and cannot be installed where support storage will be attached.

HOW TO SPECIFY

Select
Model Number

HLSL3014MM.

Select
Mixed Material

FT01 Frosted Translucent

FT01

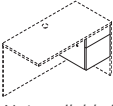
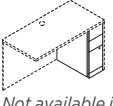
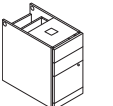
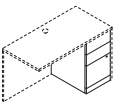
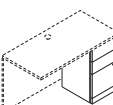

10500 SERIES™ Laminate Modular Components

	DESCRIPTION	MODEL	SHIP WEIGHT	CUBE	LIST PRICE BY LAMINATE GRADE	
					L1	L2
 Not available in two-tone laminate	Box/File Pedestal (with core removable lock) 15 $\frac{5}{8}$ "W x 22 $\frac{3}{4}$ "D x 17 $\frac{3}{4}$ "H — for use under 24"D, 30"D and 36"D desk, credenza and return shells NOTES: Attaches to underside of worksurface top. Lock can be positioned on either the right or left side. File drawer includes integrated hangrails for letter- or legal-sized folders. Not for use under 20"D shells. ⓘ Not designed to be used freestanding. Unfinished top and back.	H10501	57	5.5	\$523	\$543
 Not available in two-tone laminate	Narrow Box/Box/File Pedestal (with core removable lock) — floor-standing 9 $\frac{1}{2}$ "W x 22 $\frac{3}{4}$ "D x 28"H — for use under 24"D, 30"D and 36"D desk, credenza and return shells NOTES: Space-saving design supports smaller footprints. Middle box drawer and file drawer lock; top box drawer does not lock. File drawer includes integrated hangrails for side-to-side letter or legal filing. Not for use under 20"D shells. ⓘ Not designed to be used freestanding. Unfinished top and back.	H105093	61	5.6	\$676	\$701
 Not available in two-tone laminate	Box/Box/File Pedestal — floor-standing 15 $\frac{5}{8}$ "W x 28 $\frac{3}{4}$ "D x 28"H — for use under 10500 Series 30"D worksurfaces supported by 29 $\frac{7}{8}$ "D L-shaped end panel model H10530LEP NOTES: Top box drawer does not lock. File drawer includes integrated hangrails for letter- or legal-sized folders. Not for use under shells, per "Inside Dimensions" listings. ⓘ Not designed to be used freestanding. Unfinished top and back.	H105062	105	10.5	\$743	\$773
 Not available in two-tone laminate	Box/Box/File Pedestal (with core removable lock) — floor-standing 15 $\frac{5}{8}$ "W x 22 $\frac{3}{4}$ "D x 28"H — for use under 24"D, 30"D and 36"D desk, credenza and return shells or worksurface supported by 23 $\frac{7}{8}$ "D L-shaped end panel(s) NOTES: Top box drawer does not lock. File drawer includes integrated hangrails for letter- or legal-sized folders. Not for use under 20"D shells. ⓘ Not designed to be used freestanding. Unfinished top and back.	H10502	90	8.4	\$686	\$711
 Not available in two-tone laminate	Box/Box/File Pedestal (with core removable lock) — floor-standing 15 $\frac{5}{8}$ "W x 18 $\frac{3}{4}$ "D x 28"H — for use under 20"D, 24"D, 30"D and 36"D desk, credenza and return shells NOTES: Top box drawer does not lock. File drawer includes integrated hangrails for letter- or legal-sized hanging folders. ⓘ Not designed to be used freestanding. Unfinished top and back.	H105012	73	7.3	\$647	\$667

NOTES:

- Pedestals can be reconfigured quickly and easily when user preferences or space needs change.
- Locking units equipped with interchangeable core removable locks.
- Pedestal models ship assembled unless designated .
- Mobile pedestals shown on page 281, work well in a variety of configurations.
- Narrow Pedestal features a compact design that is ideal for use in U- and L-shaped layouts for smaller spaces such as a 5' x 8' U-shaped workstation or a 5' x 5' L-shaped workstation.
- 10500 Series™ modular pedestals are for use with desk, credenza and return shells (see pages 244-248), as well as L-shaped end panels (page 250).
- ⓘ Keyed alike cores must be ordered separately — see model HF23B on page 746 — makes re-keying quick and easy.
- ⓘ Access strip (filler) required when box/box file, file/file, and or narrow box/box/file pedestals are configured side-by-side to allow access for opening the drawers.
- ⓘ Modular pedestals can be specified as one color only; not available in two-tone laminate combination or in a pattern laminate.

HOW TO SPECIFY

Select Model Number H 1 0 5 0 9 3	Select Laminate Chassis Color See pages 236-237 N
---	--



10500 SERIES™

Laminate Modular Components

GSA SIN 33721

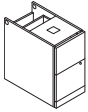
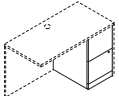
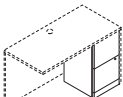

Icon Legend on page 19

	DESCRIPTION	MODEL	SHIP WEIGHT	CUBE	LIST PRICE BY LAMINATE GRADE	
					L1	L2
 Not available in two-tone laminate	File/File Pedestal — floor-standing 15 $\frac{5}{8}$ "W x 28 $\frac{3}{4}$ "D x 28"H — for use under 10500 Series 30"D worksurfaces supported by 29 $\frac{7}{8}$ "D L-shaped end panel model H10530LEP NOTES: File drawer includes integrated hangrails for letter- or legal-sized folders. Not for use under shells, per "Inside Dimensions" listings. ⓘ Not designed to be used freestanding. Unfinished top and back.	H105064	104	10.5	\$743	\$773
 Not available in two-tone laminate	File/File Pedestal (with core removable lock) — floor-standing 15 $\frac{5}{8}$ "W x 22 $\frac{3}{4}$ "D x 28"H — for use under 24"D, 30"D and 36"D desk, credenza and return shells or worksurface supported by 23 $\frac{7}{8}$ "D L-shaped end panel(s) NOTES: File drawers include integrated hangrails for letter- or legal-sized folders. Not for use under 20"D shells. ⓘ Not designed to be used freestanding. Unfinished top and back.	H10504	85	8.2	\$686	\$711
 Not available in two-tone laminate	File/File Pedestal (with core removable lock) — floor-standing 15 $\frac{5}{8}$ "W x 18 $\frac{3}{4}$ "D x 28"H — for use under 20"D, 24"D, 30"D and 36"D desk, credenza and return shells NOTES: File drawers include integrated hangrails for letter- or legal-sized folders. ⓘ Not designed to be used freestanding. Unfinished top and back.	H105014	72	7.3	\$647	\$667
 Not available in two-tone laminate	Access Strip (Filler) 1 $\frac{1}{8}$ "W x 20 $\frac{1}{2}$ "D x 28"H NOTES: For use under 24"D, 30"D and 36"D desk, credenza or return shells when B/B/F, F/F, and or narrow B/B/F pedestals are configured side-by-side. Not required when pedestals are used in conjunction with lateral file pedestals, multi file pedestals or cabinet pedestal. Not sized for use with 20"D modular shells. NOTE: See pages 244-248 for desk, credenza and return shells.	H10524	21	0.9	\$176	\$186

NOTES:

- Pedestals can be reconfigured quickly and easily when user preferences or space needs change.
- Locking units equipped with interchangeable core removable locks.
- Pedestal models ship assembled unless designated .
- Mobile pedestals shown on page 281, work well in a variety of configurations.
- Narrow Pedestal features a compact design that is ideal for use in U- and L-shaped layouts for smaller spaces such as a 5' x 8' U-shaped workstation or a 5' x 5' L-shaped workstation.
- 10500 Series™ modular pedestals are for use with desk, credenza and return shells (see pages 244-248), as well as L-shaped end panels (page 250).
- ⓘ Keyed alike cores must be ordered separately — see model HF23B on page 746 — makes re-keying quick and easy.
- ⓘ Access strip (filler) required when box/box file, file/file, and or narrow box/box/file pedestals are configured side-by-side to allow access for opening the drawers.
- ⓘ Modular pedestals can be specified as one color only; not available in two-tone laminate combination or in a pattern laminate.

HOW TO SPECIFY

Select Model Number <input type="text" value="H10504"/>	Select Laminate Chassis Color See pages 236-237 <input type="text" value="N"/>
---	---



10500 SERIES™

Laminate Modular Components

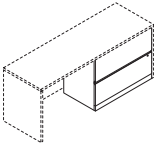
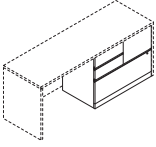
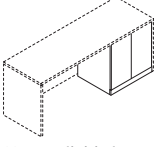
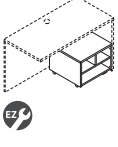
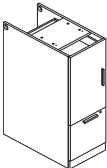
	DESCRIPTION	MODEL	SHIP WEIGHT	CUBE	LIST PRICE BY LAMINATE GRADE	
					L1	L2
 <p>Not available in two-tone laminate</p>	Lateral File Pedestal (with core removable lock) — Floor-standing 36"W x 20"D x 28"H — For use under 24"D, 30"D and 36"D desk, credenza and return shells NOTES: Drawers include integrated hangrails for letter- or legal-sized folders. Mechanical interlock inhibits extension of more than one drawer at a time. Not for use under 20"D shells. ! Not designed to be used freestanding. Unfinished top and back.	H10503	127	15.6	\$1042	\$1082
 <p>Not available in two-tone laminate</p>	Multi File Pedestal (with core removable lock) — Floor-standing 36"W x 20"D x 28"H — For use under 24"D, 30"D and 36"D desk, credenza and return shells NOTES: Versatile four drawer unit features a lateral file, vertical file, and two box drawers. Box drawers do not lock. File drawers include integrated hangrails for letter- or legal-sized folders. Mechanical interlock in lateral drawer inhibits extension of more than one drawer at a time. Not for use under 20"D shells. ! Not designed to be used freestanding. Unfinished top and back.	H10505	155	15.6	\$1249	\$1289
 <p>Not available in two-tone laminate</p>	Cabinet Pedestal — Floor-standing 26"W x 21¼"D x 28"H — For use under 24"D, 30"D and 36"D desk, credenza and return shells NOTES: One adjustable shelf at 2½" increments. Doors are non-locking. Not for use under 20"D shells. ! Not designed to be used freestanding. Unfinished top and back.	H10508	78	12.2	\$777	\$817
 <p>Not available in two-tone laminate</p>	Mobile Printer/Fax Cart 20"W x 19⅞"D x 14⅞"H — For use under 24"D, 30"D and 36"D desk, credenza and return shells NOTES: Holds laser printers, inkjet printers or fax machines. Ideal for limited space. Low profile cart stores conveniently and easily under desks and workstations. Interior compartment shelving is Black. Four casters. Specify laminate top and chassis color. Not for use under 20"D shells. SPECIFYING EXAMPLE: H105679.NN	H105679	52	2.9	\$420	\$440
 <p>Not available in two-tone laminate</p>	Box/Shelf/File Pedestal 15⅝"W x 28¾"D x 41"H — For 30"D worksurfaces 15⅝"W x 22¾"D x 41"H — For 24"D or 30"D worksurfaces NOTES: For 42"H standing-height desks. Designed to be used under a component worksurface supported on the pedestal end(s) by 41"H L-shaped end panel(s). For single pedestal workstations, the non-pedestal end can be supported by a 41"H L-shaped end panel, H-leg, or O-leg. Adjustable hex glides allow floor-standing units to be easily leveled without lifting to compensate for uneven floors; glides have ¾" adjustable range. Cabinet includes one box (supply) drawer and two shelves (one fixed, one adjustable); shelf adjusts in 1¼" increments with a range of 5". Not to be used freestanding, top and back are not enclosed. Pedestal depth is less than the depth of the respective component top to accommodate L-shaped end panel. File drawer includes integrated hangrails. Standard with linear handles in black finish.	H105077 H105076	104 89	14.7 11.9	\$1434 \$1384	\$1489 \$1434

NOTES:

- Pedestals can be reconfigured quickly and easily when user preferences or space needs change.
- File drawers accept hanging folders in letter or legal size.
- Mobile pedestals shown on page 281, work well in a variety of configurations.
- Locking units equipped with interchangeable core removable locks.
- Pedestal models ship assembled unless designated .
- See pages 244-248 for desk, credenza and return shells.

 Keyed alike cores must be ordered separately — see model HF23B on page 746 — makes re-keying quick and easy.

 Access strip (filler) required when box/box file, file/file, and or narrow box/box/file pedestals are configured side-by-side to allow access for opening the drawers.

HOW TO SPECIFY

Select Model Number H 1 0 5 0 3 . N	Select Laminate Chassis Color See pages 236-237
---	---

10500 SERIES™

Laminate Wood Desks — Full Pedestals

GSA SIN 33721



Icon Legend on page 19

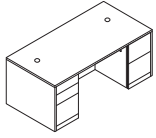

DESCRIPTION	FULL WIDTH OVERHANG	MODEL	SHIP WEIGHT	CUBE	LIST PRICE BY LAMINATE GRADE	
					L1	L2
Double Pedestal Desk						
72"W x 36"D x 29½"H, Bow Top, 3/2	10½"	H105899	315	50.9	\$1867	\$1947
72"W x 36"D x 29½"H, Rectangle Top, 3/2	10½"	H105890	340	50.9	\$1702	\$1777
66"W x 30"D x 29½"H, Rectangle Top, 3/2	4½"	H105891	290	39.4	\$1586	\$1651
60"W x 30"D x 29½"H, Rectangle Top, 3/2	4½"	H105892	278	35.9	\$1491	\$1551

NOTES: All drawers lock. Two cord grommets in top for routing and hiding wires and cables. Bow top models measure 36"D at crest and 30"D along the end panels. See page 289 for optional center drawers.

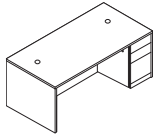

Single Pedestal Desk						
72"W x 36"D x 29½"H, Bow Top, Right	10½"	H105893R	292	50.9	\$1530	\$1600
72"W x 36"D x 29½"H, Rectangle Top, Right	10½"	H105895R Ⓢ	278	50.9	\$1361	\$1431
66"W x 30"D x 29½"H, Rectangle Top, Right	4½"	H105897R	226	39.4	\$1229	\$1284
72"W x 36"D x 29½"H, Bow Top, Left	10½"	H105894L	292	50.9	\$1530	\$1600
72"W x 36"D x 29½"H, Rectangle Top, Left	10½"	H105896L Ⓢ	278	50.9	\$1361	\$1431
66"W x 30"D x 29½"H, Rectangle Top, Left	4½"	H105898L	226	39.4	\$1229	\$1284

NOTES: Box/box/file drawers. Drawers lock. Two cord grommets in top for routing and hiding wires and cables. Bow top models measure 36"D at crest and 30"D along the end panels. See page 289 for optional center drawers.

NOTES:

- Factory-configured desks, credenzas and returns ship fully assembled for ease and speed of installation.
- Full-to-floor pedestals maximize storage space.
- Smooth, flat edges provide a clean look.
- Tops are easy-care, scratch-, spill- and stain-resistant laminate over 1⅞" solid core high-performance particleboard.
- 3" round cord management grommets, for routing and hiding wires and cables, are located in the tops of desks, returns, bridges, and corner units. Grommet cutout accepts optional Power Hub (model HGRMTAC) or Power/USB Hub (model HGRMTUSB2) — see page 294.
- For work-in-process paper management tools, see pages 289-290.
- Drawers operate on full extension, ball-bearing suspensions to ensure smooth, quiet, long-lasting operation.
- File drawer design includes integrated hangrails for side-to-side letter or legal filing; and front-to-back for letter filing.
- For field installable decorative handle options, see page 292.
- All drawers are five-sided construction for added strength and easy alignment or replacement of drawer fronts.
- Center drawers conveniently store writing instruments, paper and other miscellaneous items. Includes pencil tray. See page 295.

HOW TO SPECIFY

Select
Model Number

H 1 0 5 8 9 9 .

Select
Laminate Top and Chassis Color

See pages 236-237

N N

10500 SERIES™ Laminate Wood Desks — Full Pedestals

	DESCRIPTION	FULL WIDTH OVERHANG	MODEL	SHIP WEIGHT	CUBE	LIST PRICE BY LAMINATE GRADE	
						L1	L2
	Return, file/file						
	48"W x 24"D x 29½"H, Right		H105905R	167	24.2	\$962	\$1002
	42"W x 24"D x 29½"H, Right		H105907R	147	21.4	\$941	\$981
	48"W x 24"D x 29½"H, Left		H105906L	167	24.2	\$962	\$1002
	42"W x 24"D x 29½"H, Left		H105908L	147	21.4	\$941	\$981
NOTES: Return is for use with single pedestal desks, desk shells, peninsulas or corner units. One worksurface grommet and one cord pass-through grommet in top center of modesty panel to reach wall electrical outlets. Drawers lock. Not to be used freestanding. Will not attach to Corner Units manufactured prior to 5/24/99. See pages 272-273 for optional Stack-on Storage.							
	Credenza with Doors						
	72"W x 24"D x 29½"H	3½"	H105909	323	34.8	\$1762	\$1827
NOTES: All drawers lock. Doors are non-locking. Includes a fixed shelf located at the bottom of the center storage area. No intermittent shelf. See pages 272-273 for optional Stack-on Storage.							
	Credenza with Kneespace, file/file						
	72"W x 24"D x 29½"H	3½"	H105900	274	34.8	\$1493	\$1553
	66"W x 24"D x 29½"H	3½"	H105901	262	32.0	\$1478	\$1538
	60"W x 24"D x 29½"H	3½"	H105902	248	29.2	\$1423	\$1478
NOTES: All drawers lock. One cord pass-through grommet in top center of modesty panel to reach wall electrical outlets. Not designed for use with 22¾"D modular or mobile pedestals. Modesty/back panel is inset 3½". See pages 272-273 for optional Stack-on Storage.							
	Single Pedestal Credenza, file/file						
	72"W x 24"D x 29½"H, Right (shown)	3½"	H105903R	226	34.8	\$1210	\$1265
	72"W x 24"D x 29½"H, Left	3½"	H105904L	226	34.8	\$1210	\$1265
NOTES: Drawers lock. One cord pass-through grommet in top center of modesty panel to reach wall electrical outlets. Not designed for use with 22¾"D modular or mobile pedestals. Modesty/back panel is inset 3½". See pages 272-273 for optional Stack-on Storage.							
	Low Credenza						
	72"W x 20"D x 21½"H, Drawers Right, Bookcase Left		H105975R	219	23.5	\$1324	\$1384
	72"W x 20"D x 21½"H, Drawers Left, Bookcase Right		H105976L	219	23.5	\$1324	\$1384
	60"W x 20"D x 21½"H, Drawers Right, Bookcase Left		H105973R	187	19.7	\$1219	\$1274
	60"W x 20"D x 21½"H, Drawers Left, Bookcase Right		H105974L	187	19.7	\$1219	\$1274
NOTES: Combines with overlapping, 29½"H worksurfaces to create a multi-level workstation for a modern aesthetic. For use in open plan spaces or private offices. Two locking drawers (1 box and 1 file) and open shelving. File drawers include integrated handrails for letter- or legal-sized folders. Bookcase has one adjustable shelf; adjusts in 1¼" increments with a range of 6". Overlapping surfaces can be supported by a 28½"H H-leg or O-leg, or 7"H O-leg, or by 7"H laminate end panel. On 60"W models, grain on back panel runs vertical for all woodgrain laminates. On 72", grain on back panel runs vertical for L1 woodgrains except for Florence and Kingswood Walnuts and horizontal on L2 laminates and Florence and Kingswood Walnuts. Optional seat cushions HLSL2036CH2 for 72"W and HLSL2030CH2 for 60"W.							

NOTES:

- Factory-configured desks, credenzas and returns ship fully assembled for ease and speed of installation.
 - Formal, full-length modesty panels.
 - Tops are easy-care, scratch-, spill- and stain-resistant laminate over 1/8" solid core high-performance particleboard.
 - 3" round cord management grommets, for routing and hiding wires and cables, are located in the tops of desks, returns, bridges, and corner units. Grommet cutout accepts optional Power Hub (model HGRMTAC) or Power/USB Hub (model HGRMTUSB2) — see page 294.
 - Drawers operate on full extension, ball-bearing suspensions to ensure smooth, quiet, long-lasting operation.
 - All drawers are five-sided construction for added strength and easy alignment or replacement of drawer fronts.
 - File drawer design includes integrated handrails for side-to-side letter or legal filing; and front-to-back for letter filing.
 - For field installable decorative handle options, see page 292.
 - 10500 Series™ 18¾"D modular and mobile pedestals can be positioned under credenza with kneespace and single pedestal credenza models.
- 1** Keyed alike cores must be ordered separately — see model HF23B on page 746 — makes re-keying quick and easy.

HOW TO SPECIFY

Select Model Number	Select Laminate Top and Chassis Color See pages 236-237 Kickplates will match chassis color
<input type="text" value="H105905R."/>	<input type="text" value="NN"/>

10500 SERIES™ Laminate Wood Desks — Full Pedestals

OPEN MARKET

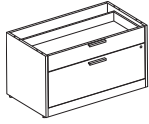

DESCRIPTION	MODEL	SHIP WEIGHT	CUBE	L1 LIST	L2 UPCHARGES	
					CHASSIS	FRONTS
2-Drawer Credenza, No Top 36"W x 24"D x 19 7/8"H	H105LC3624BF	105.5	13.9	\$525	\$35	\$20
36"W x 20"D x 19 7/8"H	H105LC3620BF	97.9	11.7	\$525	\$30	\$20
30"W x 24"D x 19 7/8"H	H105LC3024BF	92.3	11.7	\$556	\$30	\$15
30"W x 20"D x 19 7/8"H	H105LC3020BF	85.4	9.9	\$505	\$25	\$15

NOTES: Use in conjunction with Modular Credenza tops on page 265.

① Keyed alike cores must be ordered separately — see model HF23B on page 746 — makes re-keying quick and easy.

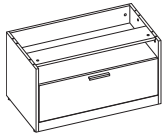

DESCRIPTION	MODEL	SHIP WEIGHT	CUBE	L1 LIST	L2 UPCHARGES	
					CHASSIS	FRONTS
Open/Lateral Credenza, No Top 36"W x 24"D x 19 7/8"H	H105LC3624SF	117.2	13.9	\$505	\$35	\$20
36"W x 20"D x 19 7/8"H	H105LC3620SF	106.1	11.7	\$505	\$30	\$20
30"W x 24"D x 19 7/8"H	H105LC3024SF	101.7	11.7	\$490	\$30	\$15
30"W x 20"D x 19 7/8"H	H105LC3020SF	91.8	9.9	\$490	\$25	\$15

NOTES: Use in conjunction with Modular Credenza tops on page 265. Drawer is non-locking.



DESCRIPTION	MODEL	SHIP WEIGHT	CUBE	LIST PRICE BY LAMINATE GRADE	
				L1	L2
Open HAT Credenza, No Top 36"W x 24"D x 19 7/8"H	H105LCHAT3624S	82.3	13.9	\$240	\$275
36"W x 20"D x 19 7/8"H	H105LCHAT3620S	71.2	11.7	\$240	\$270
30"W x 24"D x 19 7/8"H	H105LCHAT3024S	72.2	11.7	\$220	\$250
30"W x 20"D x 19 7/8"H	H105LCHAT3020S	62.3	9.9	\$220	\$245

NOTES: False back allows HAT base leg to be concealed. Use in conjunction with Modular Credenza tops with HAT cutout on page 265.

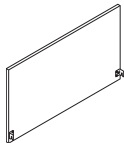

DESCRIPTION	MODEL	SHIP WEIGHT	CUBE	LIST PRICE BY LAMINATE GRADE	
				L1	L2
Back for Open Storage Cabinet 36"W x 19 7/8"H	H105LCHAT3620B	25.0	2.1	\$220	\$235
30"W x 19 7/8"H	H105LCHAT3020B	25.0	1.8	\$200	\$215

NOTES: Optional model to conceal HAT base leg when used in open office settings. Use with Open HAT Credenzas, No Top when the back of the unit will be visible in an open plan office.

NOTES:

- Units can be combined to create 60"W, 66"W, and 72"W low credenzas utilizing Modular Credenzas.
- Units have unfinished tops.
- File drawers include integrated hangrails for letter- or legal-sized folders.
- Open Credenzas have one adjustable shelf; adjusts 1/4" increments with a range of 6".
- Overlapping surfaces can be supported by a 28 1/2"H or 7"H O-leg or by 7"H laminate end panel.

HOW TO SPECIFY

<p>Select Model Number</p> <p>H 1 0 5 L C 3 6 2 0 B F .</p>	<p>Select Chassis Laminate</p> <p>See page 236 Kickplates will match chassis color</p> <p>L F W 1 .</p>	<p>Select Door Front Laminate</p> <p>See page 236</p> <p>L F W 1 .</p>	<p>Select Pull and Color</p> <p>L Linear P Black</p> <p>L P .</p>	<p>Select Lock Option</p> <p>Only available on 2-Drawer Credenzas</p> <p>L Lock</p> <p>L</p>
--	--	---	--	---

<p>Select Model Number</p> <p>H 1 0 5 L C H A T 3 6 2 0 B .</p>	<p>Select Chassis Laminate</p> <p>See page 236 Kickplates will match chassis color</p> <p>L F W 1</p>
--	--



10500 SERIES™ Laminate Wood Desks — Full Pedestals

	DESCRIPTION	MODEL	SHIP WEIGHT	CUBE	LIST PRICE BY LAMINATE GRADE		
					L1	L2	
	Modular Credenza Tops, Height Adjustable Base						
	30"W x 24"D, Non-handed	H105CTHAT3620	23.5	2.3	\$495	\$510	
	30"W x 20"D, Non-handed	H105CTHAT3020	19.6	1.9	\$395	\$410	
	72"W x 24"D, Right	H105CTHAT7224R	72.3	5.0	\$802	\$822	
	72"W x 20"D, Right	H105CTHAT7220R	72.3	4.2	\$802	\$822	
	66"W x 24"D, Right	H105CTHAT6624R	66.3	4.6	\$744	\$764	
	66"W x 20"D, Right	H105CTHAT6620R	60.3	3.9	\$744	\$764	
	60"W x 24"D, Right	H105CTHAT6024R	60.3	4.2	\$683	\$703	
	60"W x 20"D, Right	H105CTHAT6020R	66.3	3.6	\$683	\$703	
	36"W x 24"D, Right	H105CTHAT3624R	36.1	2.6	\$495	\$510	
	36"W x 20"D, Right	H105CTHAT3620R	36.1	2.3	\$495	\$510	
	72"W x 24"D, Left	H105CTHAT7224L	72.3	5.0	\$802	\$822	
	72"W x 20"D, Left	H105CTHAT7220L	72.3	4.2	\$802	\$822	
	66"W x 24"D, Left	H105CTHAT6624L	66.3	4.6	\$744	\$764	
	66"W x 20"D, Left	H105CTHAT6620L	66.3	3.9	\$744	\$764	
	60"W x 24"D, Left	H105CTHAT6024L	60.3	4.2	\$683	\$703	
	60"W x 20"D, Left	H105CTHAT6020L	60.3	3.6	\$683	\$703	
	36"W x 24"D, Left	H105CTHAT3624L	36.1	2.6	\$495	\$510	
	36"W x 20"D, Left	H105CTHAT3020L	36.1	2.3	\$495	\$510	
	Modular Credenza Tops						
		30"W x 20"D	H105CT3020	19.6	1.9	\$395	\$410
		36"W x 20"D	H105CT3620	36.1	2.3	\$495	\$510
		30"W x 24"D	H105CT3024	23.5	2.3	\$395	\$410
	36"W x 24"D	H105CT3624	36.1	2.6	\$495	\$510	

NOTES:

- Easy care, scratch-, spill- and stain-resistant laminate over 1/8" solid core high-performance particleboard.
- Grain direction on all worksurfaces runs horizontal.
- Tops are intended to be used with modular low credenzas on page 264.
- Tops come with hardware to attach to low credenzas.
- Tops have a right or left notch to accommodate HON's Height Adjustable Base legs.

	DESCRIPTION	MODEL	SHIP WEIGHT	CUBE	LIST PRICE BY FABRIC GRADE					
					1	2	3	4	5	6
	Fabric Credenza Tops									
	36"W x 24"D x 1"H for 36"W Credenzas	HLAMSEAT3624	12	2.6	\$435	\$473	\$511	\$549	\$587	\$625
	30"W x 24"D x 1"H for 36"W Credenzas	HLAMSEAT3024	10	2.3	\$405	\$441	\$477	\$513	\$549	\$585
	36"W x 20"D x 1"H for 72"W Credenzas	HLSL2036CH2	11	2.2	\$410	\$448	\$486	\$525	\$574	\$624
	36"W x 20"D x 1"H for 60"W Credenzas	HLSL2030CH2	9	1.9	\$380	\$416	\$452	\$488	\$534	\$581
	NOTES: See pages 22-24 for available fabrics.									
	COM: .75									
	SPECIFYING EXAMPLE: HLAMSEAT3624.APN23									

HOW TO SPECIFY

<p>Select Model Number</p> <p>H 1 0 5 C T H A T 3 6 2 0 .</p>	<p>Select Laminate and Edge Color</p> <p>See page 236</p> <p>L F W 1 F W</p>
---	--

10500 SERIES™

Laminate Wood Desks — 3/4 Pedestals

GSA SIN 33721



Icon Legend on page 19

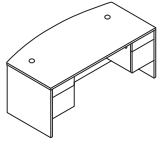

DESCRIPTION	FULL WIDTH OVERHANG	MODEL	SHIP WEIGHT	CUBE	LIST PRICE BY LAMINATE GRADE	
					L1	L2
Double Pedestal Desk						
72"W x 36"D x 29½"H, Bow Top, 2-2	10½"	H10595	300	52.9	\$1560	\$1640
72"W x 36"D x 29½"H, Rectangle Top, 2-2	10½"	H10593 ☉	320	52.9	\$1391	\$1466
66"W x 30"D x 29½"H, Rectangle Top, 2-2	4½"	H10571	286	40.9	\$1273	\$1338
60"W x 30"D x 29½"H, Rectangle Top, 2-2	4½"	H10573 ☉	271	37.4	\$1172	\$1232

NOTES: All drawers lock. Two cord grommets in top for routing and hiding wires and cables. Bow top models measure 36"D at crest and 30"D along the end panels. See page 295 for optional center drawers.

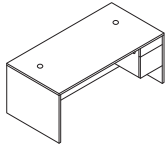

Single Pedestal Desk						
72"W x 36"D x 29½"H, Bow Top, Right	10½"	H10587R	238	52.9	\$1347	\$1417
72"W x 36"D x 29½"H, Rectangle Top, Right	10½"	H10585R	279	52.9	\$1182	\$1247
66"W x 30"D x 29½"H, Rectangle Top, Right	4½"	H10583R ☉	229	41.0	\$1039	\$1094
72"W x 36"D x 29½"H, Bow Top, Left	10½"	H10588L	238	52.9	\$1347	\$1417
72"W x 36"D x 29½"H, Rectangle Top, Left	10½"	H10586L	279	52.9	\$1182	\$1247
66"W x 30"D x 29½"H, Rectangle Top, Left	4½"	H10584L ☉	229	41.0	\$1039	\$1094

NOTES: Box/file drawers. Drawers lock. Two cord grommets in top for routing and hiding wires and cables. Bow top models measure 36"D at crest and 30"D along the end panels. See page 295 for optional center drawers.

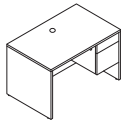

Small Office Desk						
48"W x 30"D x 29½"H, 3/4 Pedestal, Right box/file	4½"	H105885R	168	30.5	\$923	\$963

NOTES: Small footprint makes this desk ideal for limited space. Drawers lock. One cord grommet in top for routing and hiding wires and cables. 3/4 height modesty panel facilitates reaching wall electrical outlets. Optional stack-on storage model H105323 maximizes storage space; see page 272.

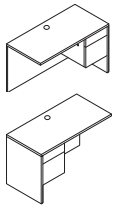

Return, box/file						
48"W x 24"D x 29½"H, Right		H10515R ☉	147	25.6	\$837	\$877
42"W x 24"D x 29½"H, Right		H10511R	138	20.5	\$819	\$859
48"W x 24"D x 29½"H, Left		H10516L ☉	147	25.6	\$837	\$877
42"W x 24"D x 29½"H, Left		H10512L	138	20.5	\$819	\$859

NOTES: Return is for use with single pedestal desks, desk shells, peninsulas or corner units. One worksurface grommet and one cord pass-through grommet in top center of modesty panel to reach wall electrical outlets. Drawers lock. See pages 272-273 for optional stack-on storage.

ⓘ Not designed to be used freestanding. Will not attach to Corner Units manufactured prior to 5/24/99.

NOTES:

- For components that can be shared with 10500 Series™, see pages 268-295.
- Tops and end panels are abrasion- and stain-resistant laminate over durable 1½" solid core high-performance particleboard; resists warping.
- Formal, full height modesty panels.
- 3/4 pedestal design increases budget flexibility.
- 3" round cord management grommets, for routing and hiding wires and cables, are located in the tops of desks, returns, bridges, and corner units. Grommet cutout accepts optional Power Hub (model HGRMTAC) or Power/USB Hub (model HGRMTUSB2) — see page 294.
- All drawers are 5-sided construction, which allows easy drawer alignment or replacement of drawer fronts.
- Drawers operate on full extension, ball-bearing suspensions to ensure smooth, quiet, long-lasting operation.
- File drawer design includes integrated hangrails for side-to-side letter or legal filing; and front-to-back for letter filing.
- For field installable decorative handle options, see page 292.
- Desk, credenza, and return models ship assembled.
- See stack-on storage and stack-on PC organizer options on pages 271-273.
- Use with Above Worksurface Privacy Screens. See page 258.
- Mobile table quickly provides additional worksurface space, see page 269.

HOW TO SPECIFY

Select Model Number

H 1 0 5 9 5 .

Select Laminate Top and Chassis Color

See pages 236-237

N N



10500 SERIES™

Laminate Wood Desks — 3/4 Pedestals

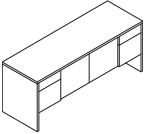
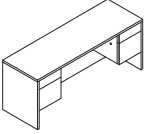
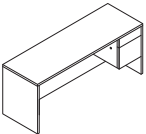
	DESCRIPTION	FULL WIDTH OVERHANG	MODEL	SHIP WEIGHT	CUBE	LIST PRICE BY LAMINATE GRADE	
						L1	L2
	Credenza with Doors 72"W x 24"D x 29½"H NOTES: All drawers lock. Doors are non-locking. Includes a fixed shelf located at the bottom of the center storage area. No intermittent shelf. See pages 272-273 for optional stack-on storage.	3½"	H10544	278	36.0	\$1512	\$1577
	Credenza with Kneespace — box/file 72"W x 24"D x 29½"H 66"W x 24"D x 29½"H 60"W x 24"D x 29½"H NOTES: All drawers lock. One cord pass-through grommet in top center of modesty panel to reach wall electrical outlets. ⓘ Not designed to be used with 22¾"D modular or mobile pedestals. Modesty/back panel is inset 3½".	3½" 3½" 3½"	H10543 ⓘ H10566 H10565 ⓘ	243 234 229	36.3 33.4 28.8	\$1240 \$1228 \$1172	\$1300 \$1288 \$1227
	Single Pedestal Credenza — box/file 72"W x 24"D x 29½"H, Right (shown) 72"W x 24"D x 29½"H, Left NOTES: Drawers lock. One cord pass-through grommet in top center of modesty panel to reach wall electrical outlets. See page 272 for optional stack-on storage. ⓘ Not designed to be used with 22¾"D modular or mobile pedestals. Modesty/back panel is inset 3½".	3½" 3½"	H10545R H10546L	212 212	36.0 36.0	\$1023 \$1023	\$1078 \$1078

NOTES:

- For components that can be shared with 10500 Series™, see pages 268-295.
- Tops and end panels are abrasion- and stain-resistant laminate over durable 1½" solid core high-performance particleboard; resists warping.
- Formal, full height modesty panels.
- 3/4 pedestal design increases budget flexibility.
- 3" round cord management grommets, for routing and hiding wires and cables, are located in the tops of desks, returns, bridges, and corner units. Accepts optional Power Hub Grommet model HGRMTAC — page 294.
- All drawers are 5-sided construction, which allows easy drawer alignment or replacement of drawer fronts.
- Drawers operate on full extension, ball-bearing suspensions to ensure smooth, quiet, long-lasting operation.
- File drawer design includes integrated hangrails for side-to-side letter or legal filing; and front-to-back for letter filing.
- For field installable decorative handle options, see page 292.
- Desk, credenza, and return models ship assembled.
- See stack-on storage and stack-on PC organizer options on pages 271-273.
- Use with Above Worksurface Privacy Screens. See page 258.
- Mobile table quickly provides additional worksurface space, see page 269.

HOW TO SPECIFY

Select Model Number H 1 0 5 4 4 .	Select Laminate Top and Chassis Color See pages 236-237 N N
---	--

10500 SERIES™

Shared Components & Accessories

GSA SIN 33721



Icon Legend on page 19

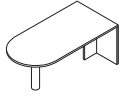

DESCRIPTION

Peninsula w/End Panel

- 72"W x 36"D x 29½"H
- 72"W x 30"D x 29½"H
- 66"W x 30"D x 29½"H
- 60"W x 30"D x 29½"H

MODEL

SHIP WEIGHT

CUBE

LIST PRICE BY LAMINATE GRADE

L1

L2

H10521	150	15.1	\$877	\$922
H105209	130	12.8	\$819	\$864
H10522	125	11.8	\$808	\$853
H10523	100	10.7	\$757	\$802

NOTES: Use for "U" or "L" configuration. 60"W size ideal for smaller spaces. Cord routing notch in brace panel. Accepts field installable modesty panel model H10528. Accepts center drawer model H1526 and H1522. Model H1522 can be used in conjunction with the laminate modesty panel model H10528. Round support column is black.

⚠ Not designed to be used freestanding.

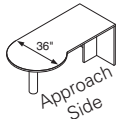

- 72"W x 30/36"D x 29½"H, P-shaped Right (shown)
- 72"W x 36/30"D x 29½"H, P-shaped Left

- H10525R**
- H10526L**

- 142
- 142

- 13.4
- 13.4

NOTES: Use for "U" or "L" configuration. Cord routing notch in brace panel. Accept field installable modesty panel model H10528 (see page 269). See page 295 for optional center drawers. Round support column is black.

⚠ Not designed to be used freestanding.

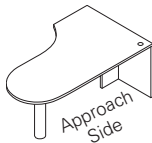

Jetty Peninsula w/End Panel

- 72"W x 30/42"D x 29½"H, Right (shown)
- 72"W x 42/30"D x 29½"H, Left

- H105201R**
- H105202L**

- 156
- 156

- 16.9
- 16.9

NOTES: For use in "U" or "L" configuration. Designed and sized to efficiently serve as both a computing and conferencing space. One cord management grommet in the top; cord routing notch in brace panel. Round support column is black.

⚠ Not designed to be used freestanding. Jetty units manufactured on or after 10/24/2005 accept field installable modesty panel H10528 (see page 269).

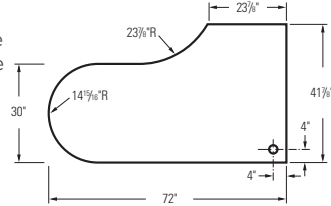

Right-hand model H105201R shown

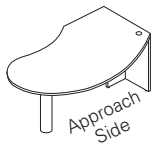

Boomerang Peninsula w/End Panel

- 72"W x 30/42"D x 29½"H, Right (shown)
- 72"W x 42/30"D x 29½"H, Left

- H105203R**
- H105204L**

- 152
- 152

- 16.9
- 16.9

NOTES: For use in "U" or "L" configuration. Designed and sized to efficiently serve as both a computing and conferencing space. One cord management grommet in the top; cord routing notch in brace panel. Round support column is black.

⚠ Not designed to be used freestanding. Accept field installable modesty panel H10528 (see page 269).

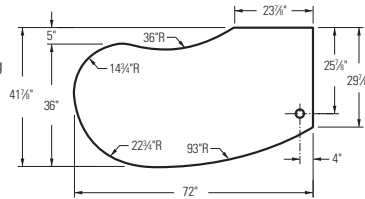

Right-hand model H105203R shown

NOTES:

- Shared components shown on this page can be used with modular components shown on pages 244-261, full pedestal models shown on pages 262-263 and 3/4 pedestal models shown on pages 266-267.
- Jetty, boomerang and rudder peninsulas are designed and sized to efficiently serve as both a computing and conferencing space.
- Peninsulas ship complete with end panel and black 3" diameter support column. For a silver support column option, please see model HPC191X on page 251 (ordered separately).
- Mobile pedestals shown on page 281 work well in a variety of configurations.
- Adjustable hex leveling glides allow floor-standing furniture to be easily leveled without lifting the unit; glides have 3/4" adjustable range.
- See pages 268-295 for shared components.

HOW TO SPECIFY

<p>Select Model Number</p> <p>H 1 0 5 2 5 R .</p>	<p>Select Laminate Top and Chassis Color</p> <p>See pages 236-237</p> <p>N N</p>
---	--



10500 SERIES™

Shared Components & Accessories

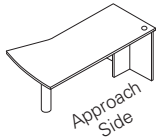

Model H105205R shown

**DESCRIPTION**

Rudder Peninsula with End Panel
72"W x 30/38"D x 29½"H, Right (shown)
72"W x 30/38"D x 29½"H, Left

MODEL

H105205R
H105206L

SHIP WEIGHT

142
142

CUBE

15.8
15.8

LIST PRICE BY LAMINATE GRADE

L1	L2
\$1113	\$1158
\$1113	\$1158

NOTES: Use for "U" or "L" configuration. One cord management grommet in top; cord routing notch in brace panel. 30"D along end panel. Round support column is black.

⚠ Not designed to be used freestanding.

**Field Installable Laminate Modesty Panel for Peninsulas**

50¼"W x ¾"Thick x 18"H

H10528

25

1.3

\$188**\$198**

NOTES: Center drawer model H1522 can be used in conjunction with the laminate modesty panel. Laminate modesty panel has a cord pass-through notch in top corner.

⚠ Not compatible with Peninsula models H10525R, H10526L, H10621, H10721, H10722 manufactured prior to 12/1/2001 or jetty models H105201R and H105202L manufactured prior to 10/24/2005.

SPECIFYING EXAMPLE: H10528.N**DESCRIPTION****Field Installable Modesty Panel, Frosted with Silver Frame**

50¼"W x ¾"Thick x 18"H — for use on 72"W peninsulas

MODEL**HPC180G****SHIP WEIGHT**

33 Ⓞ

CUBE

1.5

LIST PRICE**\$694**

⚠ Center drawers not designed to be used with the frosted/silver modesty panel. Cord pass-through notch is not available on the Frosted/Silver model HPC180G. Notch is on laminate model H10528 only.

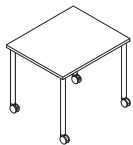
**DESCRIPTION****Mobile Table**

36"W x 30"D x 29½"H

30"W x 24"D x 29½"H

MODEL

H105T3036C
H105T2430C

SHIP WEIGHT

56
42

CUBE

11.0
7.1

LIST PRICE BY LAMINATE GRADE

L1	L2
\$640	\$655
\$573	\$585

NOTES: Rectangle-shaped top. Versatile design quickly provides additional worksurface space; ideal for work-in-process, meetings, and special projects. Choose from two sizes to align with either 30" and 36"D or 24" and 30"D worksurfaces. Roll easily on 4 casters; 2 locking, 2 non-locking. Top and legs ship together in one carton. Simple assembly. Easy-care, scratch-, spill- and stain-resistant laminate over 1½" solid core high-performance particleboard.

Specify: Model.Worksurface Laminate.Edge Color.Base Paint Color

SPECIFYING EXAMPLE: H105T3036C.N.N.S**NOTES:****Panels**

- Shared components shown on this page can be used with modular components shown on pages 244-261, full pedestal models shown on pages 262-263 and ¾ pedestal models shown on pages 266-267.
- Jetty, boomerang and rudder peninsulas are designed and sized to efficiently serve as both a computing and conferencing space.
- Peninsulas ship complete with end panel and black 3" diameter support column. For a silver support column option, please see model HPC191X on page 251 (ordered separately).
- Mobile pedestals shown on page 281 work well in a variety of configurations.
- Adjustable hex leveling glides allow floor-standing furniture to be easily leveled without lifting the unit; glides have ¾" adjustable range.
- See pages 268-295 for shared components.

HOW TO SPECIFY

Select Model Number <input type="text" value="H105205R"/>	Select Laminate Top and Chassis Color See pages 236-237 <input type="text" value="NN"/>		
Select Model Number <input type="text" value="H105T3036C"/>	Select Worksurface Laminate See pages 236-237 <input type="text" value="N"/>	Select Edge Color See pages 236-237 <input type="text" value="N"/>	Select Base Paint Color See page 236 <input type="text" value="S"/>

10500 SERIES™

Shared Components & Accessories

GSA SIN 33721



Icon Legend on page 19



DESCRIPTION	MODEL	SHIP WEIGHT	CUBE	LIST PRICE BY LAMINATE GRADE	
				L1	L2
Bridge (Single Ped. Desk, Desk Shell, or Peninsula, to Corner Unit, Single Ped. Credenza or Credenza Shell)					
47"W x 24"D x 29½"H (Clear inside depth = 21⅞"D)	H10570	76	2.8	\$364	\$394
42"W x 24"D x 29½"H (Clear inside depth = 21⅞"D)	H10560	72	2.6	\$350	\$380
Bridge (for use with Corner or Extended Corner Units or Jetty or Boomerang Peninsulas)					
36"W x 24"D x 29½"H (Clear inside depth = 21⅞"D)	H105599	61	2.6	\$350	\$380
Bridge (for use with Corner or Extended Corner Units)					
30"W x 24"D x 29½"H (Clear inside depth = 21⅞"D)	H105598	50	1.9	\$350	\$380
NOTES: One cord grommet in top; one pass-through grommet in top center of modesty panel. Grommet can be replaced with optional Power Hub or Power/USB Hub for easy plug-and-play (see page 294). Kneespace of desk limited to 24¾"W if bridge is used with 66"W single pedestal desk.					
! Not designed to attach to corner units manufactured prior to 5/24/99.					
Bridge (Single Ped. Desk, Desk Shell, or Peninsula to Single Ped. Credenza or Credenza Shell)					
47"W x 20"D x 29½"H (Clear inside depth = 17⅞"D)	H105699	61	2.8	\$350	\$380
42"W x 20"D x 29½"H (Clear inside depth = 17⅞"D)	H105698	54	2.6	\$325	\$355
NOTES: One cord grommet in top; one pass-through grommet in top center of modesty panel.					
! Models H105699 and H105698 cannot be connected to corner or extended corner units or to the jetty or boomerang peninsulas, due to the 20"D "hook-up".					

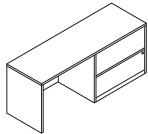

Credenza with 36" Lateral (with core removable lock)					
72"W x 24"D x 29½"H, Right (shown)	H10547R	248	35.6	\$1400	\$1460
72"W x 24"D x 29½"H, Left	H10548L	248	35.6	\$1400	\$1460
NOTES: One cord pass-through grommet in top center of modesty panel. Includes hangrails. Mechanical interlock inhibits the extension of more than one drawer at a time. Accepts optional stack-on storage model H10534 (page 272) or PC Organizer model H105388 (page 271).					
! Not designed to be used with 10500 Series™ 22¾"D modular or mobile pedestals. Modesty/back panel is inset 3½".					

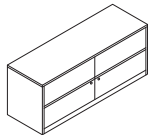

Credenza with two Lateral Files (4 locking drawers. Each core removable lock secures 2 drawers)					
72"W x 24"D x 29½"H	H105491	314	34.7	\$2021	\$2096
NOTES: Includes hangrails; mechanical interlock inhibits the extension of more than one drawer at a time. If side-by-side drawers are opened or closed simultaneously, one drawer may interfere with the other. Two locks (keyed alike). Accepts optional stack-on storage model H10534 (page 272) or PC Organizer model H105388 (page 271).					

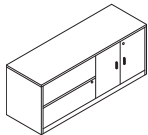

Credenza with Lateral File, left and Storage Cabinet, right (with core removable locks)					
72"W x 24"D x 29½"H	H105492	307	34.7	\$1768	\$1843
NOTES: Includes hangrails; mechanical interlock inhibits the extension of more than one drawer at a time. Storage cabinet locks and includes one adjustable interior shelf. Shelf adjusts in 1/4" increments with a total range of 5"H. Two locks (keyed alike). Accepts optional stack-on storage model H10534 (page 272) or PC Organizer model H105388 (page 271).					

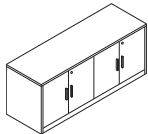

Credenza with Two Storage Cabinets (with core removable locks)					
72"W x 24"D x 29½"H	H105493	302	34.8	\$1648	\$1723
NOTES: Each storage cabinet has one interior shelf which adjusts in 1/4" increments over a total range of 5". Each cabinet locks independently; locks are keyed alike. Accepts optional stack-on storage model H10534 (page 272) or PC Organizer model H105388 (page 271).					

NOTES:

- Shared components shown on this page can be used with modular components shown on pages 244-261, full pedestal models shown on pages 262-263, and 3/4 pedestal models shown on pages 266-267.
- Locking units equipped with interchangeable core removable locks.
- File drawers accept hanging folders in letter or legal size.
- Mobile pedestals shown on page 281 work well in a variety of configurations.
- Work Organizer models accept 3-ring binders and organizer model HTC052. See page 287.
- See stack-on storage and organizer options for desks, credenzas and returns, pages 271-273.
- See pages 268-295 for shared components.

! Keyed alike cores must be ordered separately — see model HF23B on page 746.

HOW TO SPECIFYSelect
Model Number

H 1 0 5 7 0 .

Select
Laminate Top and Chassis Color

See pages 236-237

N N



Icon Legend on page 19

10500 SERIES™

Shared Components & Accessories

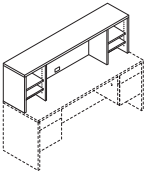
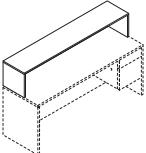
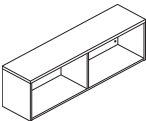
	DESCRIPTION	MODEL	SHIP WEIGHT	CUBE	LIST PRICE BY LAMINATE GRADE	
					L1	L2
	Stack-on PC Organizer					
	72"W x 14 ⁵ / ₈ "D x 22"H (for 72"W desks, credenzas and shells) 60"W x 14 ⁵ / ₈ "D x 22"H (for 60"W desks, credenzas and shells)	H105388 H105386	124 111	5.0 4.3	\$814 \$755	\$849 \$790
	NOTES: Features two adjustable paper management shelves both left and right; shelves are adjustable in 1/4" increments. Shelves keep papers, files, and books within easy reach from a seated position. One cord management grommet located in the bottom center of the back panel. Design allows 20 ³ / ₄ " of vertical clearance for computer equipment.					
	Work Organizer (shell only)					
	72"W x 14 ⁵ / ₈ "D x 14 ¹ / ₈ "H (for 72"W unit) 66"W x 14 ⁵ / ₈ "D x 14 ¹ / ₈ "H (for 66"W unit)	H10537 H10536	73 68	2.9 2.7	\$421 \$400	\$451 \$430
	NOTES: Space below counter accepts 3-ring binders and organizer model HTC0L52. See page 287.					
	Open Shared Storage					
	60"W x 14 ⁵ / ₈ "D x 16 ⁷ / ₈ "H 48"W x 14 ⁵ / ₈ "D x 16 ⁷ / ₈ "H	H105368 H105367	81 68	14.2 11.5	\$769 \$749	\$799 \$774
	NOTES: Attaches to laminate end panels with horizontally mounted interlocking brackets. Mounting applications include: 60"W — two 30"D desks/desk shells, 60"W — two 48"W (minimum) x 30"D rectangle worksurfaces supported by 28 ¹ / ₂ "H L-shaped end panels, 48"W — two 24"D credenzas/credenza shells, 48"W — two 24"D returns/return shells, 48"W — two 60"W (minimum) x 24"D rectangle worksurfaces supported by 28 ¹ / ₂ "H L-shaped end panels. Can also be positioned on the worksurface; double-sided tape included. Grain direction is vertical on top, back, end panels, and shelf. Ships fully assembled. Not designed for attachment to a worksurface supported by H-legs or O-legs. Inside dimensions for 60"W: each compartment 28 ³ / ₄ "W x 13 ¹ / ₂ "D x 15 ¹ / ₂ "H. Inside dimensions for 48"W: each compartment 22 ³ / ₄ "W x 13 ¹ / ₂ "D x 15 ¹ / ₂ "H.					

NOTES:

- Shared components shown on this page can be used with modular components shown on pages 244-261, full pedestal models shown on pages 262-263, and 3/4 pedestal models shown on pages 266-267.
 - Mobile pedestals shown on page 281 work well in a variety of configurations.
 - See stack-on storage and organizer options for desks, credenzas and returns, pages 271-273.
 - See pages 268-295 for shared components.
 - Locking units equipped with interchangeable core removable locks.
- ① Keyed alike cores must be ordered separately — see model HF23B on page 746.

HOW TO SPECIFY

Select Model Number H 1 0 5 3 8 8	Select Laminate Top and Chassis Color See pages 236-237 N N
---	--

10500 SERIES™

Shared Components & Accessories

GSA SIN 33721

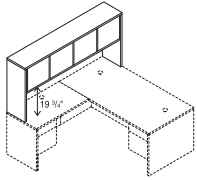

Icon Legend on page 19

**DESCRIPTION**

Stack-on Storage for an "L" Workstation
78"W x 14⁵/₈"D x 37¹/₈"H

MODEL**SHIP WEIGHT****CUBE****LIST PRICE BY LAMINATE GRADE****L1****L2****H105327**

198

17.6

\$1144**\$1209**

Stack-on Storage for an "L" Workstation, Locking

H105327K

198

17.6

\$1228**\$1293**

NOTES: Spans the total depth dimension of configurations comprised of: 48"W return or return shell attached to a 30"D single pedestal desk, desk shell or peninsula (78"D); 42"W return or return shell attached to a 36"D single pedestal desk or desk shell with a rectangle top, or to a peninsula (78"D). 42"W return or return shell attached to a 36" corner unit (78"D); or 42"W curved return attached to 36" curved corner unit (78"D). Use back enclosure model H105857 and tackboard model H90057. Use task light models HH870960 or HH870960CH (see page 559). For vertical paper manager model HLVPM1, see page 289.

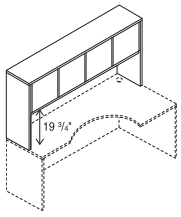
**Stack-on Storage**

72"W x 14⁵/₈"D x 37¹/₈"H, 4 doors
(Use Task Light HH870960, see page 279)
66"W x 14⁵/₈"D x 37¹/₈"H, 4 doors
(Use Task Light HH870960, see page 279)
60"W x 14⁵/₈"D x 37¹/₈"H, 4 doors
(Use Task Light HH870960, see page 279)
48"W x 14⁵/₈"D x 37¹/₈"H, 3 doors
(Use Task Light HH870942, see page 279)
42"W x 14⁵/₈"D x 37¹/₈"H, 2 doors
(Use Task Light HH870942, see page 279)
36"W x 14⁵/₈"D x 37¹/₈"H, 2 doors
(Use Task Light HH870930, see page 279)

H10534

185

17.1

\$1011**\$1051****H10533**

175

15.3

\$983**\$1038****H105324**

164

14.0

\$943**\$998****H105323**

141

11.3

\$850**\$895****H105322**

135

4.0

\$696**\$741****H105321**

102

3.5

\$657**\$687****Stack-on Storage, Locking**

72"W x 14⁵/₈"D x 37¹/₈"H, 4 doors
(Use Task Light HH870960, see page 279)
66"W x 14⁵/₈"D x 37¹/₈"H, 4 doors
(Use Task Light HH870960, see page 279)
60"W x 14⁵/₈"D x 37¹/₈"H, 4 doors
(Use Task Light HH870960, see page 279)
48"W x 14⁵/₈"D x 37¹/₈"H, 3 doors
(Use Task Light HH870942, see page 279)
42"W x 14⁵/₈"D x 37¹/₈"H, 2 doors
(Use Task Light HH870942, see page 279)
36"W x 14⁵/₈"D x 37¹/₈"H, 2 doors
(Use Task Light HH870930, see page 279)

H10534K

185

17.1

\$1095**\$1150****H10533K**

175

15.3

\$1067**\$1122****H105324K**

164

14.0

\$1027**\$1082****H105323K**

141

11.3

\$913**\$958****H105322K**

135

4.0

\$738**\$783****H105321K**

102

3.5

\$699**\$739**

NOTES: For use on respective desk, credenza or return widths. Model H10534 can be used for "L" configuration comprised of 30"D desk, desk shell or peninsula and 42"W return or return shell; or a 36"D desk, desk shell, peninsula, or corner unit and 36"W return shell. Model H105323K has one lock which secures two of the three doors. See vertical paper manager model HLVPM1 on page 289.

NOTES:

- Shared components shown on this page can be used with modular components shown on pages 244-261, full pedestal models shown on pages 262-263, and 3/4 pedestal models shown on pages 266-267.
- Rich woodgrain laminate and frosted doors with silver frames adds a contemporary mixed materials option to the 10500 Series™.
- Stack-on storage models are equipped with self-closing, adjustable hinged doors and valance to hide task light.
- See page 275 for stack-on storage back enclosures and tackboards, and page 279 for task lights.
- For work-in-process paper management tools, see pages 289-290.
- See pages 268-295 for shared components.
- **Removable lock core kit for locking stack-on storage is model HF27B. See page 746.**

HOW TO SPECIFY

Select
Model Number

Select
Laminate Top and Chassis Color

See pages 236-237

H 1 0 5 3 2 7 .

N N



10500 SERIES™

Shared Components & Accessories

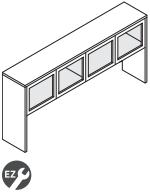
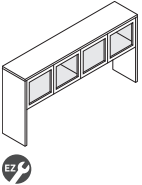
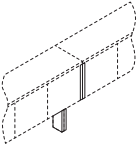
	DESCRIPTION	MODEL	SHIP WEIGHT	CUBE	LIST PRICE BY LAMINATE GRADE	
					L1	L2
	Stack-on Storage for an "L" Workstation, Frosted Doors with Silver Frame 78"W x 14 ⁵ / ₈ "D x 37 ¹ / ₈ "H NOTES: Spans the total depth dimension of configurations comprised of: 48"W return or return shell attached to a 30"D single pedestal desk, desk shell or peninsula (78"D); 42"W return or return shell attached to a 36"D single pedestal desk or desk shell with a rectangle top, or to a peninsula (78"D); 42"W return or return shell attached to a 36" corner unit (78"D); 42"W curved return attached to 36" curved corner unit (78"D); or 36"W return shell attached to a jetty peninsula (78"D). Use back enclosure model H105857 and tackboard model H90057. Use task light models HH870960 or HH870960CH. For vertical paper manager model HLVP M1, see page 289.	H105327G	198	17.3	\$1796	\$1846
	Stack-on Storage, Frosted Doors with Silver Frame 72"W x 14 ⁵ / ₈ "D x 37 ¹ / ₈ "H, 4 doors (Use Task Light HH870960, see page 279) 66"W x 14 ⁵ / ₈ "D x 37 ¹ / ₈ "H, 4 doors (Use Task Light HH870960, see page 279) 60"W x 14 ⁵ / ₈ "D x 37 ¹ / ₈ "H, 4 doors (Use Task Light HH870960, see page 279) 48"W x 14 ⁵ / ₈ "D x 37 ¹ / ₈ "H, 3 doors (Use Task Light HH870942, see page 279) 42"W x 14 ⁵ / ₈ "D x 37 ¹ / ₈ "H, 2 doors (Use Task Light HH870942, see page 279) 36"W x 14 ⁵ / ₈ "D x 37 ¹ / ₈ "H, 2 doors (Use Task Light HH870930, see page 279) NOTES: For respective desk, credenza or return widths. Model 10534 can be used for "L" configuration comprised of a 42"W return or return shell attached to a 30"D single pedestal desk, desk shell or peninsula (72"); 36"W return shell attached to a 36"D single pedestal desk, desk shell or peninsula (72"); or 30"W return shell attached to a jetty peninsula (72"). Back enclosures, tackboards for use with back enclosures and task lights are available as options. See vertical paper manager model HLVP M1 on page 289.	H10534G	185	15.9	\$1659	\$1699
		H10533G	175	14.6	\$1630	\$1670
		H105324G	164	13.3	\$1589	\$1629
		H105323G	141	10.8	\$1338	\$1368
		H105322G	135	3.6	\$1026	\$1056
		H105321G	102	3.1	\$985	\$1010
	Stack-on Storage Clearance End Panel Kit 1 ¹ / ₈ "W x 4 ⁵ / ₈ -14 ⁵ / ₈ "D x 36"H Two field installable end panels (1-right; 1-left) for use in ganging two 10500 or Valido® Series stack-on storage units. Narrow design replaces the full 14 ⁵ / ₈ "D end panels to expand worksurface space. The narrow right end panel replaces the standard 14 ⁵ / ₈ "D right end panel on one stack-on storage unit, the narrow left end panel replaces the standard 14 ⁵ / ₈ "D left end panel on a separate, adjacent stack-on storage unit that is in linear alignment with the first unit. Kit includes: (2) narrow end panel supports; European-style fasteners; dowels; joint connector bolts with sleeve nuts (for ganging stack-on storage units). NOTES: Can be used to connect up to two stack-on storage units in a line (requires 1 kit). Not available in two-tone laminate.	H105349	29	3.4	\$360	\$375

NOTES:

- Shared components shown on this page can be used with modular components shown on pages 244-261, full pedestal models shown on pages 262-263, and 3/4 pedestal models shown on pages 266-267.
- Rich woodgrain laminate and frosted doors with silver frames adds a contemporary mixed materials option to the 10500 Series™.
- Stack-on storage models are equipped with self-closing, adjustable hinged doors and valance to hide task light.
- See page 275 for stack-on storage back enclosures and tackboards, and page 279 for task lights.
- For work-in-process paper management tools, see pages 289-290.
- See pages 268-295 for shared components.
- Removable lock core kit for locking stack-on storage is model HF27B. See page 746.**

HOW TO SPECIFY

Select Model Number H 1 0 5 3 2 7 G .	Select Laminate Top and Chassis Color See pages 236-237 N N
---	--

10500 SERIES™

Shared Components & Accessories

GSA SIN 33721



Icon Legend on page 19

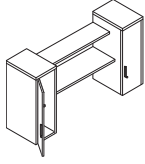

DESCRIPTION	MODEL	SHIP WEIGHT	CUBE	L1 LIST	L2 UPCHARGES	
					CHASSIS	SHELF
Stack-on Cabinets with Open Shelves, Center Overall measures: 72"W x 20"D x 37 $\frac{1}{8}$ "H Cabinet measures: 13 $\frac{1}{2}$ "W x 19 $\frac{1}{8}$ "D x 37 $\frac{1}{8}$ "H NOTES: Contemporary, light scale design blends open and closed storage. Features two locking cabinets bridged by two open shelves. The clearance between the worksurface and underside of the lower shelf is 18 $\frac{3}{8}$ ". Top shelf is 45"W x 11"D, bottom shelf is 45"W x 14"D; space between the shelves is 12 $\frac{1}{4}$ ". Some assembly required; cabinets are fully assembled; simple shelf attachment. For two-tone color combinations, the first color designator defines the top of the storage cabinet(s), the second designator defines the color of the cabinet vertical panels and the open (exterior) shelves.	H105319	218	20.3	\$1758	\$60	\$20

NOTES:

- Stack-on Cabinets with Open Shelves, Center is sized to fit on 72" desk, credenza, return, or desk with return worksurfaces.
- Easy-care, scratch-, spill- and stain-resistant laminate over 1/8" solid core high-performance particleboard.
- Cabinets have three shelves, two are adjustable.
- Removable lock core kit for the cabinet models above is HF23B. See page 746.
- Back of cabinet door has a convenient double coat hook; the lower peg is for jackets and lighter items, the upper peg for heavier coats and bags.
- Open shelves display books, photos, and mementos, shelves are fixed height; top shelf is 3/4" thick, lower shelf is 1/8".
- Task light can be attached to underside of the bottom shelf.

HOW TO SPECIFY

Select
Model Number

H 1 0 5 3 1 9 .

Select
Cabinet Top and Chassis Color

See pages 236-237

H H .

Select
Open Shelf Laminate

See pages 236-237

H



10500 SERIES™

Shared Components & Accessories

	DESCRIPTION	MODEL	SHIP WEIGHT	CUBE	LIST PRICE BY LAMINATE GRADE	
					L1	L2
 <p>18 5/8" H</p> <p>Not available in two-tone laminate</p>	Back Enclosure for Stack-on Storage					
	75 3/4" W - for 78" W model #H105327/H105327K/H105327G	H105857	39	1.4	\$259	\$269
	69 3/4" W - for 72" W model #H10534/H10534K/H10534G	H105856 ⓘ	33	1.3	\$237	\$247
	63 3/4" W - for 66" W model #H10533/H10533K/H10533G	H105855	31	1.3	\$221	\$231
	57 3/4" W - for 60" W model #H105324/H105324K/H105324G	H105854	29	1.3	\$211	\$221
	45 3/4" W - for 48" W model #H105323/H105323K/H105323G	H105853	23	0.9	\$211	\$221
	39 3/4" W - for 42" W model #H105322/H105322K/H105322G	H105852	21	0.9	\$201	\$211
33 3/4" W - for 36" W model #H105321/H105321K/H105321G	H105851	18	0.9	\$190	\$200	

NOTES: Non-tackable.

	DESCRIPTION	MODEL	COM	SHIP WEIGHT	CUBE	LIST PRICE
 <p>18" H</p>	Tackboards for use with Stack-on Back Enclosures (Back Enclosures must be ordered separately.)					
	75" W - for 78" W model #H105327 Hutch with #H105857 Enclosure	H90057	3.0	13	3.2	\$317
	68 3/4" W - for 72" W model #H10534 Hutch with #H105856 Enclosure	H90056	2.0	12	2.7	\$301
	62 3/4" W - for 66" W model #H10533 Hutch with #H105855 Enclosure	H90055	2.0	11	2.5	\$286
	56 3/4" W - for 60" W model #H105324 Hutch with #H105854 Enclosure	H90054	2.0	10	2.2	\$252
	44 3/4" W - for 48" W model #H105323 Hutch with #H105853 Enclosure	H90053	2.0	8	1.8	\$242
	39" W - for 42" W model #H105322 Hutch with #H105852 Enclosure	H90052	2.0	7	1.6	\$223
	33" W - for 36" W model #H105321 Hutch with #H105851 Enclosure	H90051	1.0	6	1.4	\$196
26 3/4" W	H90050	1.0	5	1.2	\$196	

NOTES: Specify fabric, see pages 25-26. Upcharges may apply to premium fabric grades.

ⓘ Disperse (DISP) fabric not available on sizes wider than 60". Analog (ANLG) and Exchange (EXG) not available on sizes wider than 72".

SPECIFYING EXAMPLE: H90057.APN15**NOTES:**

- When connected to the stack-on storage unit, back enclosure features full-width 1 1/8" slot at the bottom to facilitate routing cords and reaching wall electrical outlets.
- Tackboard is sized 3/4" narrower than stack-on storage back enclosure, allowing 3/8" on each side to route task light cord.
- Tackboard includes adhesive tape to secure to back enclosure and hardware for wall attachment.
- See pages 268-295 for shared components.

HOW TO SPECIFY

Select Model Number <div style="border: 1px solid black; padding: 2px; display: flex; gap: 5px;"> H105857 </div>	Select Laminate See pages 236-237 <div style="border: 1px solid black; padding: 2px; display: flex; gap: 5px;"> N </div>
---	--

10500 SERIES™

Shared Components & Accessories

GSA SIN 33721



Icon Legend on page 19

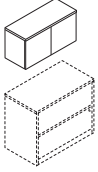

DESCRIPTION	MODEL	SHIP		LIST PRICE BY LAMINATE GRADE	
		WEIGHT	CUBE	L1	L2
Wall Mounted Storage Cabinet 48"W x 14 ⁵ / ₈ "D x 17 ¹ / ₂ "H, 3 doors (Use task light model HH870942, see page 279)	H105383	114	13.2	\$878	\$913
42"W x 14 ⁵ / ₈ "D x 17 ¹ / ₂ "H, 2 doors (Use task light model HH870942, see page 279)	H105382	97	11.7	\$821	\$856
36"W x 14 ⁵ / ₈ "D x 17 ¹ / ₂ "H, 2 doors (Use task light model HH870930, see page 279)	H105381	87	10.2	\$748	\$783
30"W x 14 ⁵ / ₈ "D x 17 ¹ / ₂ "H, 2 doors (Use task light model HH870930, see page 279)	H105380	73	8.7	\$697	\$732
Wall Mounted Storage Cabinet, Locking 48"W x 14 ⁵ / ₈ "D x 17 ¹ / ₂ "H, 3 doors (Use task light model HH870942, see page 279)	H105383K	114	13.2	\$941	\$976
42"W x 14 ⁵ / ₈ "D x 17 ¹ / ₂ "H, 2 doors (Use task light model HH870942, see page 279)	H105382K	97	11.7	\$863	\$898
36"W x 14 ⁵ / ₈ "D x 17 ¹ / ₂ "H, 2 doors (Use task light model HH870930, see page 279)	H105381K	87	10.2	\$790	\$825
30"W x 14 ⁵ / ₈ "D x 17 ¹ / ₂ "H, 2 doors (Use task light model HH870930, see page 279)	H105380K	73	8.7	\$739	\$774

NOTES: Horizontal interlocking rails are included; due to varying types of walls, installers are responsible for selecting and supplying the appropriate fasteners. Tackboard widths differ slightly from wall mounted storage cabinet widths. For applications where multiple wall mounted storage cabinets are placed side-by-side, the preferred tackboard solution may be to utilize a larger tackboard size. For wall mounted storage cabinets with frosted doors, see page 279.

SPECIFYING EXAMPLE: H105380.NN
If Specifying with Lock Option: H105380K.NN

NOTES:

- Tackboard is sized ³/₄" narrower than stack-on storage back enclosure, allowing ³/₈" on each side to route task light cord.
- Wall attachment methodology: horizontally mounted, interlocking brackets.
- Wall mounted storage cabinet door design overlaps end panels so that when multiple units are placed side-by-side they appear as one continuous unit.
- Wall mounted storage cabinets available with laminate doors, locking laminate doors or frosted doors.
- Removable lock core kit for locking stack-on and wall mounted storage is model HF27B. See page 746.
- See pages 268-295 for shared components.

- ! Wall mounted storage cabinet attachment requires individual cabinets be secured by a minimum of two wall mounting locations/studs.
- ! Wall mounted storage cabinets are designed for interior and perimeter walls that are constructed with wood or metal studs.
- ! The HON Company is not responsible for any liabilities resulting from wall mounted storage cabinets that are not properly installed.

HOW TO SPECIFY

Select Model Number	Select Laminate Top and Chassis Color See pages 236-237
H 1 0 5 3 8 0 K .	N N



Icon Legend on page 29

10500 SERIES™ Shared Components & Accessories

	DESCRIPTION	MODEL	SHIP WEIGHT	CUBE	L1 LIST	L2 UPCHARGES	
						CHASSIS	FRONTS
	Wall Mounted Hutch						
	66"W x 14 5/8"D x 15"H, 4 doors	H105WMH66	120	16.1	\$1282	\$30	\$30
	48"W x 14 5/8"D x 15"H, 3 doors	H105WMH48	97	12.6	\$918	\$25	\$30
	42"W x 14 5/8"D x 15"H, 2 doors	H105WMH42	77	10.7	\$861	\$25	\$20
	36"W x 14 5/8"D x 15"H, 2 doors	H105WMH36	67	9.8	\$788	\$25	\$20
	30"W x 14 5/8"D x 15"H, 2 doors	H105WMH30	57	8.3	\$737	\$25	\$20
	Wall Mounted Cubby Hutch						
	66"W x 14 5/8"D x 20"H, 4 doors	H105WMH66C	155	19.6	\$1282	\$30	\$30
	48"W x 14 5/8"D x 20"H, 3 doors	H105WMH48C	128	15.2	\$918	\$25	\$30
	42"W x 14 5/8"D x 20"H, 2 doors	H105WMH42C	114	13.0	\$861	\$25	\$20
	36"W x 14 5/8"D x 20"H, 2 doors	H105WMH36C	89	11.8	\$788	\$25	\$20
	30"W x 14 5/8"D x 20"H, 2 doors	H105WMH30C	76	10.0	\$737	\$25	\$20
	Wall Mounted Open Hutch						
	72"W x 14 5/8"D x 15"H, 2 Doors	H105WMH72P	119	17.5	\$1400	\$35	\$35
	66"W x 14 5/8"D x 15"H, 2 Doors	H105WMH66P	111	16.1	\$1282	\$30	\$30
	60"W x 14 5/8"D x 15"H, 2 Doors	H105WMH60P	104	14.7	\$1161	\$30	\$30
	48"W x 14 5/8"D x 15"H, 2 Doors	H105WMH48P	89	12.6	\$1040	\$25	\$30
	Wall Mounted Open Hutch with Cubby						
	72"W x 14 5/8"D x 20"H, 2 Doors	H105WMH72PC	162	21.3	\$1400	\$35	\$35
	66"W x 14 5/8"D x 20"H, 2 Doors	H105WMH66PC	151	19.6	\$1282	\$30	\$30
	60"W x 14 5/8"D x 20"H, 2 Doors	H105WMH60PC	140	14.7	\$1161	\$30	\$30
	48"W x 14 5/8"D x 20"H, 2 Doors	H105WMH48PC	117	12.6	\$1040	\$25	\$30

NOTES:

- Wall attachment methodology: horizontally mounted, interlocking brackets.
- Wall mounted storage cabinet door design overlaps end panels so that when multiple units are placed side-by-side they appear as one continuous unit.
- Laminate doors are non-locking.
- Horizontal interlocking rails are included; due to varying types of walls, installers are responsible for selecting and supplying the appropriate fasteners. Tackboard widths differ slightly from wall mounted storage cabinet widths. For applications where multiple wall mounted storage cabinets are placed side-by-side, the preferred tackboard solution may be to utilize a larger tackboard size.
- ! Wall mounted storage cabinet attachment requires individual cabinets be secured by a minimum of two wall mounting locations/studs.
- ! Wall mounted storage cabinets are designed for interior and perimeter walls that are constructed with wood or metal studs.
- ! The HON Company is not responsible for any liabilities resulting from wall mounted storage cabinets that are not properly installed.

HOW TO SPECIFY

<p>Select Model Number</p> <p>H 1 0 5 W M H 4 8</p>	<p>Select Laminate Top and Chassis Color</p> <p>See page 236</p> <p>N N</p>	<p>Select Door Front Laminate</p> <p>See page 236</p> <p>N</p>
---	---	--

10500 SERIES™

Shared Components & Accessories

OPEN MARKET

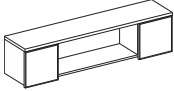
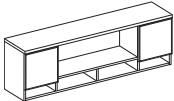

Icon Legend on page 19

	DESCRIPTION	MODEL	SHIP		LIST PRICE BY LAMINATE GRADE	
			WEIGHT	CUBE	L1	L2
	Wall Mounted Open Hutch, Glass Doors					
	72"W x 14 ⁵ / ₈ "D x 15"H, 2 Doors	H105WMH72PG	162	17.5	\$1900	\$1935
	66"W x 14 ⁵ / ₈ "D x 15"H, 2 Doors	H105WMH66PG	115	16.1	\$1782	\$1812
	60"W x 14 ⁵ / ₈ "D x 15"H, 2 Doors	H105WMH60PG	108	14.7	\$1661	\$1691
	48"W x 14 ⁵ / ₈ "D x 15"H, 2 Doors	H105WMH48PG	93	12.6	\$1540	\$1570
	Wall Mounted Open Hutch with Cubby, Glass Doors					
	72"W x 14 ⁵ / ₈ "D x 20"H, 2 Doors	H105WMH72PCG	166	21.3	\$1900	\$1935
	66"W x 14 ⁵ / ₈ "D x 20"H, 2 Doors	H105WMH66PCG	155	19.6	\$1782	\$1812
	60"W x 14 ⁵ / ₈ "D x 20"H, 2 Doors	H105WMH60PCG	144	17.9	\$1661	\$1691
	48"W x 14 ⁵ / ₈ "D x 20"H, 2 Doors	H105WMH48PCG	121	15.2	\$1540	\$1570

NOTES:

- Wall attachment methodology: horizontally mounted, interlocking brackets.
 - Wall mounted storage cabinet door design overlaps end panels so that when multiple units are placed side-by-side they appear as one continuous unit.
 - Rich woodgrain laminate and frosted doors with silver frames adds a contemporary mixed materials option to the 10500 Series™.
 - Horizontal interlocking rails are included; due to varying types of walls, installers are responsible for selecting and supplying the appropriate fasteners. Tackboard widths differ slightly from wall mounted storage cabinet widths. For applications where multiple wall mounted storage cabinets are placed side-by-side, the preferred tackboard solution may be to utilize a larger tackboard size.
- ⚠ Wall mounted storage cabinet attachment requires individual cabinets be secured by a minimum of two wall mounting locations/studs.
 - ⚠ Wall mounted storage cabinets are designed for interior and perimeter walls that are constructed with wood or metal studs.
 - ⚠ The HON Company is not responsible for any liabilities resulting from wall mounted storage cabinets that are not properly installed.

HOW TO SPECIFY

Select
Model Number

H 1 0 5 W M H 6 6 P G .

Select
Laminate Top and Chassis Color

See page 236

N N



Icon Legend on page 19

10500 SERIES™ Storage

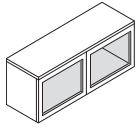

DESCRIPTION	MODEL	SHIP WEIGHT	CUBE	LIST PRICE BY LAMINATE GRADE	
				L1	L2
Wall Mounted Storage Cabinet, Frosted Doors with Silver Frame					
48"W x 14 ⁵ / ₈ "D x 17 ¹ / ₂ "H	H105383G	114.0	13.9	\$1368	\$1393
42"W x 14 ⁵ / ₈ "D x 17 ¹ / ₂ "H	H105382G	97.0	12.3	\$1154	\$1179
36"W x 14 ⁵ / ₈ "D x 17 ¹ / ₂ "H	H105381G	87.0	10.7	\$1079	\$1104
30"W x 14 ⁵ / ₈ "D x 17 ¹ / ₂ "H	H105380G	73.0	9.1	\$1027	\$1052

NOTES: Door design overlaps end panels so that when multiple units are placed side-by-side they appear as one continuous unit. Product placement can be aligned to match the height of storage cabinets, wardrobes and towers. Equipped with self-closing, adjustable side-hinged doors. The 30", 36", and 42"W units have two doors; the 48"W has three doors. Frosted door units do not have a lock option. Wall attachment methodology: horizontally mounted, interlocking brackets.

Tackboard widths differ slightly from wall mounted storage cabinet widths. For applications where multiple wall mounted storage cabinets are placed side-by-side, the preferred tackboard width may be to utilize a larger tackboard size.

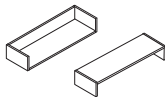

Not available in two-tone laminate



DESCRIPTION	MODEL	SHIP WEIGHT	CUBE	LIST PRICE BY LAMINATE GRADE	
				L1	L2
Wall Mounted Open Shelf					
48"W x 9 ⁷ / ₈ "D x 4 ³ / ₄ "H	H105363	18.0	1.2	\$309	\$329
42"W x 9 ⁷ / ₈ "D x 4 ³ / ₄ "H	H105362	16.0	0.8	\$280	\$300
36"W x 9 ⁷ / ₈ "D x 4 ³ / ₄ "H	H105361	14.0	0.8	\$254	\$269
30"W x 9 ⁷ / ₈ "D x 4 ³ / ₄ "H	H105360	12.0	0.8	\$241	\$256

NOTES: Ideal for books, photographs, and mementos up to 9"D. Two attachment orientation options, open ended shelf or shelf with book ends. Available in woodgrain or solid color laminates only. No patterns. No two-tone combinations. Simple assembly.

SPECIFYING EXAMPLE: H105363.N

NOTES:

- Easy-care, scratch-, spill- and stain-resistant laminate over solid core high-performance particleboard.
- Stacked paper management (model HLVPM2), which is 32¹/₂"W, is compatible with the 30"W and 36"W wall mounted storage cabinets.
- ! Wall mounted storage cabinet attachment requires individual cabinets be secured by a minimum of two wall mounting locations/studs.
- ! Wall mounted storage cabinets are designed for interior and perimeter walls that are constructed with wood or metal studs.
- ! The HON Company is not responsible for any liabilities resulting from wall mounted storage cabinets that are not properly installed.



OPEN MARKET

DESCRIPTION	MODEL	SHIP WEIGHT	CUBE	LIST PRICE
LED Task Lights				
31" LED Light with Power Supply (Single)	HLED31AS ☉	1.5 ☉	0.09	\$564
17" LED Light with Power Supply (Single)	HLED17AS ☉	1.2 ☉	0.05	\$420
31" LED Light with Power Supply for Daisy-chain (Starter)	HLED31A	1.4 ☉	0.09	\$619
17" LED Light with Power Supply for Daisy-chain (Starter)	HLED17A	1.0 ☉	0.05	\$461
31" LED Light with 8" Jumper Cord for Daisy-chain (Follower)	HLED31AUO ☉	1.0 ☉	0.05	\$503
17" LED Light with 8" Jumper Cord for Daisy-chain (Follower)	HLED17AUO ☉	1.0 ☉	0.03	\$377
Undercabinet Occupancy Sensor with 1" End to End Connector	HLEDOSA ☉	0.2 ☉	0.01	\$89

NOTES: To use the daisy chain application, must start with model HLED17A or HLED31A. No finish specification required. Attaches magnetically to underside of overhead storage, or attaches with provided screws or double-sided tape. Occupancy sensor attaches to a single or starter LED light and will automatically turn the light off after no motion is detected for 30 minutes. Just like all the LED light models, the occupancy sensor features a soft-touch on/off switch. LED task lights have a lifetime of 50,000 hours and have a dimmer feature that allows the user to adjust the amount of light output.

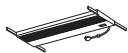

Refer to the Workplace Tools section in the 2021 Shared Spaces Pricer

OPEN MARKET

Recessed Task Light , 46 ¹ / ₂ "W x 3 ¹ / ₈ "D, for Models H105327, H10534, H10533 and H105324	HH870960	12.0 ☉	1.1	\$270
Recessed Task Light , 34 ⁵ / ₈ "W x 3 ¹ / ₈ "D, for Models H105323, H105322, H105382 and H105383	HH870942	10.0 ☉	0.9	\$250
Recessed Task Light , 22 ⁷ / ₈ "W x 3 ¹ / ₈ "D, for Models H105321, H105380 and H105381	HH870930	7.0 ☉	0.6	\$231

NOTES: For additional information see the Workplace Tools section in the 2021 Shared Spaces Pricer.

HOW TO SPECIFY

<p>Select Model Number</p> <p>H 1 0 5 3 8 3 G .</p>	<p>Select Laminate Top and Chassis Color</p> <p>See pages 236-237</p> <p>H H</p>
--	---

10500 SERIES™

Shared Components & Accessories

GSA SIN 33721



Icon Legend on page 19

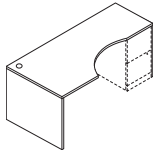

Right-hand model H105815R shown



DESCRIPTION

Extended Corner Unit

24"W x 36"D x 72"W x 24"D x 29½"H, Right (shown)
24"D x 72"W x 36"D x 24"W x 29½"H, Left

MODEL

H105815R
H105816L

SHIP WEIGHT **CUBE**

184 7.0
184 7.0

LIST PRICE BY LAMINATE GRADE

L1 **L2**
\$1074 **\$1119**
\$1074 **\$1119**

NOTES: Intended for use with returns or bridges. Can be used freestanding. The 17" user side dimension is designed to accommodate 10500 Series™ modular or mobile pedestals up to 15¾"W. One grommet in top and one cord pass-through grommet in modesty panel. See pages 271-275 for optional stack-ons and tackboards. Extended corner units (H105815R and H105816L) can be used with 36"W return shell (H105680) to achieve a 6' x 6' layout.

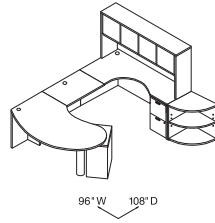
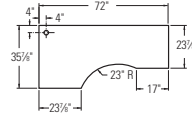

H105204L
H105102
H105598
H105815R
H105104
H10534
H105520

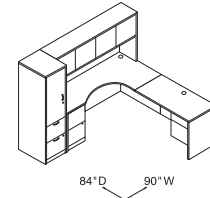

H105298L
H105816L
H10504
H10534
H10515R

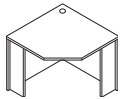

Corner Unit

24" x 36" x 36" x 24" x 29½"H

H105811

130 3.1

\$773 **\$808**

NOTES: Intended for use with 24"D x 29½"H returns or bridges. Can be used freestanding. 36" corner unit (H105811) can be used with two 36"W return shells (H105680) to achieve a 6' x 6' layout.

⚠ Not designed to attach to returns or bridges manufactured prior to 5/24/99.

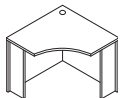
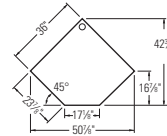

Curved Corner Unit

18" x 36" x 36" x 18" x 29½"H

H105810

128 5.4

\$773 **\$808**

NOTES: Can be used freestanding.

⚠ Designed to be used with curved returns only.

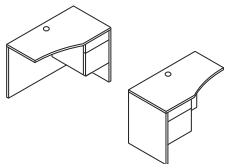

Curved Return — box/file

42"W x 18-24"D x 29½"H, Right
42"W x 24-18"D x 29½"H, Left

H105817R
H105818L

134 20.5
134 20.5

\$837 **\$877**
\$837 **\$877**

NOTES: Pedestal locks. One cord grommet in top; one pass-through grommet in top center of modesty panel. H105327 stack-on storage (78"W) can be used to span corner unit and return. H105322 stack-on storage (42"W) can be used on return. See page 272.

⚠ Designed to be used with curved corner unit only.

⚠ Not designed to be used freestanding.

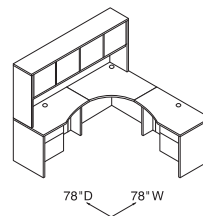

H105818L
H105810
H105327
H105817R

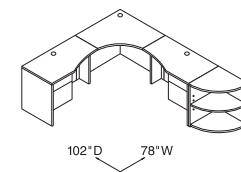

H105818
H105810
H105817R
H105520

NOTES:

- Shared components shown on this page can be used with modular components shown on pages 244-261, full pedestal models shown on pages 262-263, and 3/4 pedestal models shown on pages 266-267.
- Mobile pedestals, shown on page 281, work well in a variety of configurations.
- End cap bookshelf units are ideal for books and personal items — see page 286.
- For work-in-process paper management tools, see pages 289-290.
- For 10500 Series™ matching occasional tables, use the H80191, H80192, and H80193 on page 291.
- For conference table options, see the Preside® table tops and bases in the Tables section in the 2021 Shared Spaces Pricer.
- Mobile table quickly provides additional worksurface space, see page 269.
- See pages 268-295 for shared components.





HOW TO SPECIFY

Select Model Number	Select Laminate Top and Chassis Color
	See pages 236-237
H 1 0 5 8 1 5 R .	N N



10500 SERIES™

Shared Components & Accessories

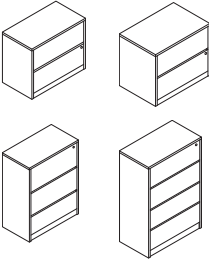
	DESCRIPTION	MODEL	SHIP WEIGHT	CUBE	LIST PRICE BY LAMINATE GRADE	
					L1	L2
	Box/Box/File Mobile Pedestal (with core removable lock) 15 ³ / ₄ "W x 22 ³ / ₄ "D x 28 ³ / ₈ "H — use freestanding or under 24"D, 30"D and 36"D modular shells NOTES: Top box drawer does not lock. File drawer includes hangrails.	H105102	121	8.5	\$854	\$894
	File/File Mobile Pedestal (with core removable lock) 15 ³ / ₄ "W x 22 ³ / ₄ "D x 28 ³ / ₈ "H — use freestanding or under 24"D, 30"D and 36"D modular shells NOTES: File drawers include hangrails.	H105104	121	8.4	\$854	\$894
	Box/File Mobile Pedestal (with core removable lock) 15 ³ / ₄ "W x 18 ⁷ / ₈ "D x 21 ⁷ / ₈ "H — use freestanding or under 20"D, 24"D, 30"D and 36"D modular shells	H105106	65	5.8	\$714	\$744
	Shelf/Box/File Mobile Pedestal (with core removable lock) 15 ³ / ₄ "W x 18 ⁷ / ₈ "D x 28 ³ / ₈ "H — use freestanding or under 20"D, 24"D, 30"D and 36"D modular shells NOTES: Interior dimensions of the open storage area of the Shelf/Box/File model are 14 ¹ / ₈ "W x 16 ³ / ₄ "D x 6 ⁵ / ₈ "H.	H105109	73	7.3	\$786	\$826
	Lateral File (with core removable lock) 36"W x 20"D x 59 ¹ / ₈ "H — four drawer 36"W x 20"D x 45 ¹ / ₂ "H — three drawer 36"W x 24"D x 29 ¹ / ₂ "H — two drawer 36"W x 20"D x 29 ¹ / ₂ "H — two drawer NOTES: Includes hangrails, mechanical interlock and in H10563 and H105690, a counterweight. Stack-on storage (H105321) and bookcase hutch (H105292) can be used with H10563 and H105690. Interlock inhibits the extension of more than one drawer from opening at a time. Model H105690 aligns with 24"D credenzas and returns.	H10516 ☉ H10517 H105690 H10563 ☉	305 240 191 170	31.0 23.2 17.6 15.6	\$2105 \$1598 \$1023 \$973	\$2175 \$1663 \$1078 \$1023

NOTES:

- For additional components that can be shared with 10500 Series™, see pages 268-295.
- Mobile pedestals feature clean styling with hidden casters. Versatile designs roll easily and work well in a variety of configurations. Can be used freestanding, under modular shells, or with 10500 Series™ component worksurfaces and supports.
- 24"D lateral file, storage cabinet, and bookcase models align evenly with credenzas and returns to provide linear layout continuity.
- At 45¹/₂"H, the three-drawer lateral file can be used as a standing-height worksurface or to support office equipment.
- Drawers operate on full extension, ball-bearing suspensions to ensure smooth, quiet, long-lasting operation.
- File drawer design includes integrated hangrails for side-to-side letter or legal filing; and front-to-back for letter filing.
- Mobile printer/fax cart shown on page 261 is ideal for limited space.

HOW TO SPECIFY

Select Model Number H 1 0 5 1 0 2	Select Laminate Top and Chassis Color See pages 236-237 N N
---	--

10500 SERIES™

Shared Components & Accessories

GSA SIN 33721 EXCEPT AS NOTED



Icon Legend on page 19

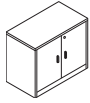

DESCRIPTION	MODEL	SHIP WEIGHT	CUBE	LIST PRICE BY LAMINATE GRADE	
				L1	L2
Storage Cabinet with Doors (with core removable lock)					
36"W x 24"D x 29½"H	H105290	168	17.6	\$927	\$982
36"W x 20"D x 29½"H	H105291	147	15.0	\$781	\$831

NOTES: Includes one adjustable shelf. Shelf adjusts in 1/4" increments with a total range of 5"H. Stack-on storage (H105321), and bookcase hutch (H105292) can be used with H105291 or H105290. Model H105290 aligns with 24"D credenzas and returns.

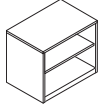

Bookcase					
36"W x 24"D x 29½"H, 2-Shelf, 1-Adjustable	H105531	102	18.4	\$757	\$772

NOTES: Adjustable shelf is 22"D and adjusts in 1/4" increments, with a total range of 5". 24" depth aligns evenly with 24"D credenzas, credenza shells, returns, return shells, and wardrobe/storage cabinets to provide linear layout continuity. Adjustable leveling glides. Accommodates the 36"W stack-on storage or bookcase hutch. Ships fully assembled.

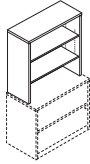

Bookcase Hutch (for use with lateral file models H10563/H105690, storage cabinet models H105291/H105290, and bookcase model H105531)					
36"W x 14½"D x 37½"H	H105292	103	3.6	\$570	\$585

NOTES: Cord pass-through gap behind shelves and a 1½"H full-width cord management slot at the bottom of the back panel. Two shelves are adjustable in 1/4" increments with a total range of 17½"H.



Multi-Use Stack-On Storage					
36"W x 18"D x 45½"H	H105310	142	21.9	\$1059	\$1094

NOTES: Non-handed. Design features user's side bookcase and end access mixed storage compartment. Three fixed bookcase compartments, each 12"W x 13¾"H. Versatile mixed storage area includes two coat hooks and two shelves; one adjustable in 1/4"H increments with a total range of 5" (shelf count includes bottom of the unit). For use on worksurfaces 36" or wider and 18" or deeper. Total height, in combination with low credenza, is 66½". Accepts markerboard models HLSL1536SOMB or HLSL1530SOMB (sold separately). Ships fully assembled.

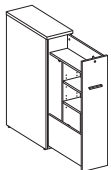

DESCRIPTION	MODEL	SHIP WEIGHT	CUBE	L1 LIST	L2 UPCHARGES	
					CHASSIS	FRONTS
Slide Out Tower						
12"W x 30"D x 50"H, Right	H105ST123050R	215	13.8	\$3000	\$60	\$20
12"W x 30"D x 50"H, Left	H105ST123050L	215	13.8	\$3000	\$60	\$20
12"W x 24"D x 50"H, Right	H105ST122450R	182	11.4	\$2705	\$50	\$20
12"W x 24"D x 50"H, Left	H105ST122450L	182	11.4	\$2705	\$50	\$20

NOTES: Wardrobe space contains one coat hook. Storage space includes three shelves; two are adjustable in 2½" increments. Door access left or right models available. Equipped with HON "One Key" interchangeable core removable locks. Standard with Black linear pull.

OPEN MARKET

NOTES:

- For additional components that can be shared with 10500 Series™, see pages 268-295.
- Versatile mobile pedestals roll easily and work well in a variety of configurations. Can be used freestanding, under modular shells, or with 10500 Series™ component worksurfaces and supports.
- 24"D lateral file, storage cabinet, and bookcase models align evenly with credenzas and returns to provide linear layout continuity.
- Mobile printer/fax cart shown on page 261 is ideal for limited space.

HOW TO SPECIFY

<p>Select Model Number</p> <p>H 1 0 5 2 9 1 .</p>	<p>Select Laminate Top and Chassis Color</p> <p>See pages 236-237</p> <p>N N .</p>			
<p>Select Model Number</p> <p>H 1 0 5 S T 1 2 3 0 5 0 R .</p>	<p>Select Laminate Top and Chassis Color</p> <p>See page 236</p> <p>N N .</p>	<p>Select Door Front Laminate</p> <p>See page 236</p> <p>N .</p>	<p>Select Pull and Color</p> <p>L Linear P Black</p> <p>L P .</p>	<p>Select Lock Option</p> <p>Not available on Open Credenzas</p> <p>L Lock</p> <p>L .</p>



Icon Legend on page 19

10500 SERIES™ Shared Components & Accessories

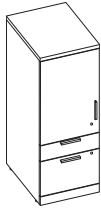

DESCRIPTION

Storage Wardrobe

24"W x 24"D x 50"H, Right
24"W x 24"D x 50"H, Left
24"W x 20"D x 50"H, Right
24"W x 20"D x 50"H, Left
18"W x 24"D x 50"H, Right
18"W x 24"D x 50"H, Left
18"W x 20"D x 50"H, Right
18"W x 20"D x 50"H, Left

MODEL

H105LT242450CBFR
H105LT242450CBFL
H105LT242050CBFR
H105LT242050CBFL
H105LT182450CBFR
H105LT182450CBFL
H105LT182050CBFR
H105LT182050CBFL

SHIP WEIGHT

202
202
178
178
168
168
147
147

CUBE

21.3
21.3
17.9
17.9
16.2
16.2
13.7
13.7

L1 LIST

\$2050
\$2050
\$2000
\$2000
\$1950
\$1950
\$1728
\$1728

L2 UPCHARGES
CHASSIS **FRONTS**

\$60 **\$35**
\$60 **\$35**
\$50 **\$35**
\$50 **\$35**
\$50 **\$30**
\$50 **\$30**
\$45 **\$30**
\$45 **\$30**

NOTES: Spacious design includes a wardrobe closet, storage cabinet, one box drawer, and one file drawer in one compact unit. Wardrobe closet contains a coat rod. Storage cabinet includes two shelves, one is adjustable in 2½" increments. Door hinged left or right models available. Box and file drawers operate on ball-bearing suspensions with full extension. File drawers have high sides to accept hanging folders in letter or legal size. Drawers standard with hangrails. Equipped with HON "One Key" interchangeable core removable locks. Upper lock secures storage cabinet and wardrobe closet doors; lower lock secures file drawers.

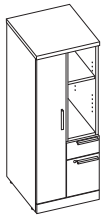

Open Wardrobe

24"W x 24"D x 50"H, Right
24"W x 24"D x 50"H, Left
24"W x 20"D x 50"H, Right
24"W x 20"D x 50"H, Left
18"W x 24"D x 50"H, Right
18"W x 24"D x 50"H, Left
18"W x 20"D x 50"H, Right
18"W x 20"D x 50"H, Left

H105LT242450BFR
H105LT242450BFL
H105LT242050BFR
H105LT242050BFL
H105LT182450BFR
H105LT182450BFL
H105LT182050BFR
H105LT182050BFL

190
190
167
167
161
161
141
141

21.3
21.3
17.9
17.9
16.2
16.2
13.7
13.7

\$2000
\$2000
\$1800
\$1800
\$1900
\$1900
\$1678
\$1678

\$60 **\$35**
\$60 **\$35**
\$50 **\$35**
\$50 **\$35**
\$50 **\$30**
\$50 **\$30**
\$45 **\$30**
\$45 **\$30**

NOTES: Spacious design includes a wardrobe closet, open storage, one box drawer, and one file drawer in one compact unit. Wardrobe closet contains a coat rod. Storage cabinet includes two shelves, one is adjustable in 2½" increments. Door hinged left or right models available. Box and file drawers operate on ball-bearing suspensions with full extension. File drawers have high sides to accept hanging folders in letter or legal size. Drawers standard with hangrails. Equipped with HON "One Key" interchangeable core removable locks. Lock secures box and file drawers; wardrobe is non-locking.



Side Access Wardrobe

24"W x 24"D x 50"H, Right
24"W x 24"D x 50"H, Left
24"W x 20"D x 50"H, Right
24"W x 20"D x 50"H, Left
18"W x 24"D x 50"H, Right
18"W x 24"D x 50"H, Left
18"W x 20"D x 50"H, Right
18"W x 20"D x 50"H, Left

H105LT242450SBFR
H105LT242450SBFL
H105LT242050SBFR
H105LT242050SBFL
H105LT182450SBFR
H105LT182450SBFL
H105LT182050SBFR
H105LT182050SBFL

187
187
166
166
153
153
135
135

21.3
21.3
17.9
17.9
16.2
16.2
13.7
13.7

\$2078
\$2078
\$1900
\$1900
\$1966
\$1966
\$1728
\$1728

\$60 **\$35**
\$60 **\$35**
\$50 **\$35**
\$50 **\$35**
\$50 **\$30**
\$50 **\$30**
\$45 **\$30**
\$45 **\$30**

NOTES: Spacious design includes a wardrobe closet, open side access storage, one box drawer, and one file drawer in one compact unit. Wardrobe closet contains a coat rod. Storage cabinet includes two shelves, one is adjustable in 2½" increments. Door hinged left or right models available. Box and file drawers operate on ball-bearing suspensions with full extension. File drawers have high sides to accept hanging folders in letter or legal size. Drawers standard with hangrails. Equipped with HON "One Key" interchangeable core removable locks. Lock secures box and file drawers; wardrobe is non-locking.

NOTES:

- Broad family of storage components beyond the confines of a desk drawer.
- Locking units equipped with interchangeable core removable locks.
- Adjustable hex leveling glides allow floor-standing furniture to be easily leveled without lifting the unit; glides have ¾" adjustable range.

HOW TO SPECIFY

<p>Select Model Number</p> <p>H 1 0 5 L T 1 8 2 4 5 0 B F R .</p>	<p>Select Laminate Top and Chassis Color</p> <p>See page 236 Kickplates will match chassis color</p> <p>N N .</p>	<p>Select Door Front Laminate</p> <p>See page 236</p> <p>N .</p>	<p>Select Pull and Color</p> <p>L Linear P Black</p> <p>L P .</p>	<p>Select Lock Option</p> <p>L Lock</p> <p>L</p>
--	--	---	--	---

10500 SERIES™

Shared Components & Accessories

OPEN MARKET



Icon Legend on page 19

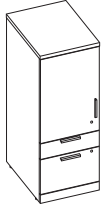

DESCRIPTION	MODEL	SHIP WEIGHT	CUBE	L1 LIST	L2 UPCHARGES	
					CHASSIS	FRONTS
Storage Cabinet 18"W x 24"D x 50"H, Right	H105LT182450SCBFR	158	16.2	\$1575	\$50	\$30
18"W x 24"D x 50"H, Left	H105LT182450SCBFL	158	16.2	\$1575	\$50	\$30

NOTES:

- Versatile unit features a storage cabinet, one box drawer, and one file drawer.
- Storage cabinet includes two shelves, one is adjustable in 2½" increments.
- Door hinged left or right models available.
- File drawers operate on ball-bearing suspensions with full extension.
- File drawers have high sides to accept hanging folders in letter or legal size.
- Drawers standard with hangrails.
- Both the storage cabinet and the file drawers are equipped with a HON "One Key" interchangeable core removable lock.
- Upper lock secures storage cabinet; lower lock secures box and file drawers.
- Broad family of storage components beyond the confines of a desk drawer.
- Locking units equipped with interchangeable core removable locks.
- Adjustable hex leveling glides allow floor-standing furniture to be easily leveled without lifting the unit; glides have ¾" adjustable range.



HOW TO SPECIFY

Select Model Number H 1 0 5 L T 1 8 2 4 5 0 S C B F R .	Select Laminate Top and Chassis Color See page 236 Kickplates will match chassis color N N .	Select Door Front Laminate See page 236 N .	Select Pull and Color L Linear P Black L P .	Select Lock Option L Lock L
--	---	---	---	--

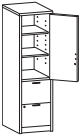

10500 SERIES™

Shared Components & Accessories

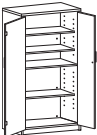
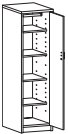
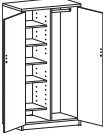
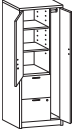
	DESCRIPTION	MODEL	SHIP WEIGHT	CUBE	LIST PRICE BY LAMINATE GRADE	
					L1	L2
 <p>Right-hand model H105297R shown</p>	Storage/File Cabinet (with core removable locks)					
	18"W x 24"D x 66 $\frac{5}{8}$ "H, Hinged Right (shown)	H105297R	258	22.7	\$1692	\$1767
	18"W x 24"D x 66 $\frac{5}{8}$ "H, Hinged Left	H105298L	258	22.7	\$1692	\$1767
	NOTES: Versatile unit features a storage cabinet and two file drawers. Storage cabinet includes three shelves, two are adjustable in 2 $\frac{1}{2}$ " increments. Door hinged left or right models available. File drawers operate on ball-bearing suspensions with full extension. File drawers have high sides to accept hanging folders in letter or legal size. Drawers standard with hangrails. Both the storage cabinet and the file drawers are equipped with a HON "One Key" interchangeable core removable lock. Unit height is designed to match credenza or return plus stack-on storage height.					
 <p>Doors open 110 degrees from closed position.</p>	Storage Cabinet/Lateral File (with core removable lock)					
	36"W x 24"D x 66 $\frac{5}{8}$ "H	H105293	365	41.0	\$2278	\$2378
	NOTES: Storage cabinet is standard with one fixed and two full-width adjustable shelves in top compartment; adjustable shelves can be removed. Overall storage compartment measures 31 $\frac{1}{4}$ "W x 22"D x 36 $\frac{1}{8}$ "H and will accommodate supplies, books and binders, as well as business machines and electronic equipment. Cord pass-through gap behind shelves and grommet in back of the cabinet to facilitate routing cords and reaching wall electrical outlets. Two drawer lateral file on bottom. Lateral file comes with mechanical interlock and hangrails. Cabinet and lateral file lock independently. Unit height is designed to match credenza or return plus stack-on storage height.					
 <p>Doors open 110 degrees from closed position.</p>	Storage Cabinet with Full-width Shelves (with core removable lock)					
	36"W x 24"D x 66 $\frac{5}{8}$ "H	H105299	341	39.6	\$2126	\$2226
	NOTES: Large storage area includes five, full-width (side-to-side) shelves; three are adjustable in 2 $\frac{1}{2}$ " increments. Unit height matches credenza or return plus stack-on storage height.					
 <p>Right-hand model H105295R shown</p>	Personal Wardrobe/Storage Cabinet (with core removable lock)					
	18"W x 24"D x 66 $\frac{5}{8}$ "H, Hinged Right (shown)	H105295R	223	22.9	\$1533	\$1608
	18"W x 24"D x 66 $\frac{5}{8}$ "H, Hinged Left	H105296L	223	22.9	\$1533	\$1608
	NOTES: Unit is standard with four adjustable shelves, coat rod, and core removable lock. Shelves adjust in 2 $\frac{1}{2}$ " increments. Cabinet can be used as a wardrobe by removing four adjustable shelves. Coat rod can be removed from cabinet for storage only applications. Unit height is designed to match credenza or return plus stack-on storage height.					
 <p>Doors open 110 degrees from closed position.</p>	Personal Wardrobe/Storage Cabinet (with core removable lock)					
	36"W x 24"D x 66 $\frac{5}{8}$ "H	H10530	341	41.0	\$2278	\$2290
	NOTES: Spacious design is standard with four adjustable shelves (one shelf is fixed), coat rod and core removable lock which locks both doors. Shelves adjust in 2 $\frac{1}{2}$ " increments. Unit height is designed to match credenza or return plus stack-on storage height.					
 <p>Right-hand model H105301R shown</p>	Personal Storage Tower (with core removable locks)					
	24"W x 24"D x 66 $\frac{5}{8}$ "H, wardrobe Hinged Right, storage cabinet Hinged Left (shown)	H105301R	299	27.9	\$2139	\$2234
	24"W x 24"D x 66 $\frac{5}{8}$ "H, wardrobe Hinged Left, storage cabinet Hinged Right	H105302L	299	27.9	\$2139	\$2234
	NOTES: Spacious design includes a wardrobe closet, storage cabinet, and two file drawers in one compact unit. Wardrobe closet contains a coat rod. Storage cabinet includes three shelves, two are adjustable in 2 $\frac{1}{2}$ " increments. Door hinged left or right models available. File drawers operate on ball-bearing suspensions with full extension. File drawers have high sides to accept hanging folders in letter or legal size. Drawers standard with hangrails. Equipped with HON "One Key" interchangeable core removable locks. Upper lock secures storage cabinet and wardrobe closet doors; lower lock secures file drawers. Unit height is designed to match credenza or return plus stack-on storage height.					

NOTES:

- Broad family of storage components takes organization way beyond the confines of a desk drawer.
- Locking units equipped with interchangeable core removable locks.
- Adjustable hex leveling glides allow floor-standing furniture to be easily leveled without lifting the unit; glides have $\frac{3}{4}$ " adjustable range.
- See pages 268-295 for shared components.

🔑 Keyed alike cores must be ordered separately — see model HF23B on page 746 — makes re-keying quick and easy.

HOW TO SPECIFY

Select Model Number	Select Laminate Top and Chassis Color
	See pages 236-237
H 1 0 5 2 9 7 R .	N N

10500 SERIES™

Shared Components & Accessories

GSA SIN 33721



Icon Legend on page 19



H105532 shown

**DESCRIPTION****Bookcase**

5 Shelf, 36"W x 13¹/₈"D x 71"H
 4 Shelf, 36"W x 13¹/₈"D x 57¹/₈"H
 3 Shelf, 36"W x 13¹/₈"D x 43³/₈"H
 2 Shelf, 36"W x 13¹/₈"D x 29⁵/₈"H

MODEL

H105535
H105534
H105533
H105532

SHIP WEIGHT

187
 156
 122
 90

CUBE

25.1
 20.2
 15.6
 11.0

LIST PRICE BY LAMINATE GRADE**L1**

\$825
\$710
\$602
\$474

L2

\$855
\$735
\$622
\$489

NOTES: Fixed shelves. Inside shelf dimensions on all units is 33³/₄"W x 12"D x 13"H. No assembly required.

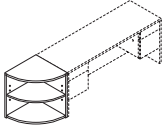
**End Cap Bookshelf (2 shelves, 1 fixed, 1 adjustable. Adjusts in 2¹/₂" increments with a total range of 10"H)**24"W x 24"D x 29¹/₂"H**H105520**

84

2.6

\$603**\$618**

NOTES: Unit is freestanding. Designed to be positioned at the end of 24"D credenzas and returns. Ideal for books, photos, plants and mementos.

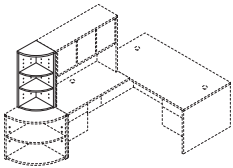
**End Cap Bookshelf (3 shelves, 1 fixed, 2 adjustable. Adjusts in 2¹/₂" increments with a total range of 25"H)**15"W x 15"D x 37¹/₈"H**H105523**

53

2.2

\$519**\$534**

NOTES: Unit is designed to be positioned at the end of stack-on storage and on top of model H105520. Combined height of models H105520 and H105523 matches credenza or return plus stack-on storage height. Can be used freestanding.

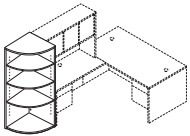
**End Cap Bookshelf**24"W x 24"D x 66⁵/₈"H**H105524**

164

4.8

\$1005**\$1030**

NOTES: Designed to be positioned at the end of 24"D credenzas with stack-on storage, 24"D returns with stack-on storage, 24"D storage/file cabinet, 24"D storage cabinet/lateral file, 24"D wardrobe/storage cabinets, or the 24"D personal storage tower. Unit has four shelves, three are adjustable in 2¹/₂" increments, with a total range of 45"H; bottom shelf is fixed.



Model H105525R



Model H105526L

Square End Cap Bookshelf — 2-Fixed Shelves24"W x 24"D x 29¹/₂"H, Right**H105525R**

92

3.6

\$598**\$613**24"W x 24"D x 29¹/₂"H, Left**H105526L**

92

3.6

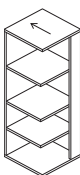
\$598**\$613**

Model H105527R

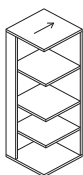

Model H105528L

Square End Cap Bookshelf — 4-Fixed Shelves24"W x 24"D x 66⁵/₈"H, Right**H105527R**

172

5.9

\$959**\$984**24"W x 24"D x 66⁵/₈"H, Left**H105528L**

172

5.9

\$959**\$984**

NOTES: Units are freestanding. Designed to be positioned next to 24"D models or as a corner bookcase.

End cap, left: grain direction on top aligns with grain direction on tops of left pedestal returns and left credenza models or when positioned to the left side of credenzas with doors or kneespace models.

End cap, right: grain direction on top aligns with grain direction on tops of right pedestal returns and right credenza models or when positioned to the right side of credenzas with doors or kneespace models.

**NOTES:**

- For 36"W x 24"D x 29¹/₂"H two-shelf bookcase, to align evenly with credenzas and returns, see page 282.

HOW TO SPECIFY

Select
Model Number

H 1 0 5 5 3 2 .

Select
Laminate Top and Chassis Color

See pages 236-237

N N

10500 SERIES™

Shared Components & Accessories

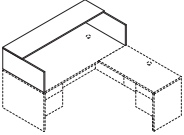
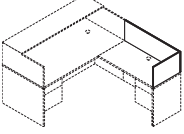
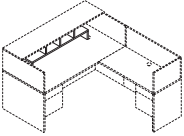
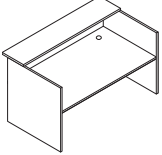
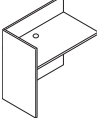
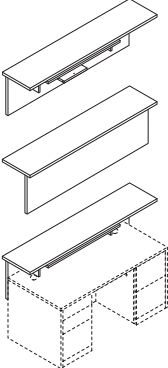
	DESCRIPTION	MODEL	SHIP WEIGHT	CUBE	LIST PRICE BY LAMINATE GRADE	
					L1	L2
	Reception Station with Transaction Counter, for 72"W x 36"D Desk, or Desk Shell, with rectangle top 72"W x 36"D x 14¼"H	H105720	92	3.0	\$504	\$539
	NOTES: For desk tops without grommets, see field installable grommet kit, model HFLDGRMT on page 294. Transaction counter organizer (HTCOL52) fits under/inside of transaction counter (see below).					
	Reception Station for 42"W x 24"D Return or Return Shell 42"W x 24"D x 13"H	H105722	2	1.0	\$253	\$273
	Reception Station for 48"W x 24"D Return or Return Shell 48"W x 24"D x 13"H	H105721	25	3.6	\$288	\$308
	NOTES: For return tops without grommets, see field installable grommet kit, model HFLDGRMT on page 294. Not available in two-tone laminate. Designed specifically for use with Reception Station with Transaction Counter, model H105720.					
	SPECIFYING EXAMPLE: H105722.N					
	DESCRIPTION	MODEL	SHIP WEIGHT	CUBE	LIST PRICE	
	Transaction Counter Organizer 48¾"W x 11⅞"D x 13"H	HTCOL52	24	1.1	\$283	
	NOTES: Fits under reception station with transaction counter model H105720 reception desk shell (H105724), and work organizer models H10537 and H10536.					
	Black only.					
	SPECIFYING EXAMPLE: HTCOL52.P					
	DESCRIPTION	MODEL	SHIP WEIGHT	CUBE	LIST PRICE BY LAMINATE GRADE	
					L1	L2
	Reception Desk Shell, with rectangle top 72"W x 39⅞"D x 44⅞"H	H105724	294	17.0	\$1077	\$1132
	NOTES: Non-handed design. Integrated 18⅝"D transaction counter with a 4" full-width overhang. Two cord management grommets in top for routing and hiding wires and cables. Transaction counter organizer model TCOL52 fits under/inside transaction counter. When a two-tone color combination is specified, the first designator defines the transaction countertop and the desk worksurface.					
	Reception Station Return Shell 42"W x 24⅜"D x 42⅝"H	H105726	131	17.0	\$750	\$785
	NOTES: Non-handed design for use with reception desk shell. One cord management grommet in top for routing and hiding wires and cables. Woodgrain on approach side is vertical to match grain direction on end panels of reception station desk. Designed specifically for use with Reception Desk Shell, model H105724.					
	Transaction Counter for Reception Desk 66"W x 14⅝"D x 14¼"H	H105729	100	4.2	\$626	\$651
	NOTES: Off-the-worksurface solution designed for use with 72"W or 66"W desks or desk shells with a 1⅞" thick rectangle top and a full-width conference (approach-side) overhang of 4½"D minimum. Choose from two height options at time of installation; 13⅞"H (upper position) or 5½"H (lower position) above the desktop. Attaches easily and securely without any drilling or double-sided tape on the worksurface. Grain direction: side-to-side on countertop; horizontal on approach and users side vertical panel.					

NOTES:

- Three welcoming reception station designs to choose from — stack-on enclosure, full-to-floor shell, or front-suspended counter.
- Versatile mobile office table is ideal for additional worksurface space, meetings, and special projects. See page 269.
- For 10500 Series™ matching reception area furniture, see Occasional Tables on page 291.
- See pages 268-295 for shared components.

HOW TO SPECIFY

Select Model Number	Select Laminate Top and Chassis Color
	See pages 236-237
H 1 0 5 7 2 0 .	N N

10500 SERIES™

Shared Components & Accessories

GSA SIN 33721



Icon Legend on page 19

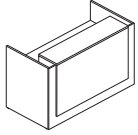

DESCRIPTION	MODEL	SHIP WEIGHT	CUBE	L1 LIST	L2 UPCHARGES		ACCENT PANEL
					WORKSURFACE	CHASSIS	
Reception Desk with Transaction Counter 72"W x 36 ³ / ₄ "D x 44"H	HLAM3772RD	324	13.5	\$1474	\$35	\$70	\$25

NOTES: Non-handed. Counter measures 60"W x 15¹/₄"D. Flat edge (G) matches 10500 Series™. For beaded (B) and tri-oval (V) edge shapes, the transaction counter is profiled on the approach and user sides, and the desk worksurface is profiled on the user's side. Beaded (B) and tri-oval (V) edges are available in L1 woodgrains colors only. Smooth and flat (G) edge available in all woodgrains and solid colors. Vertical grain on approach side and front accent panel for L1 laminates except Kingswood Walnut and Florence Walnut. Horizontal grain on L2 laminates and Kingswood and Florence Walnut. Vertical grain on end panels and horizontal grain on worksurface and transaction counter. Two worksurface cord management grommets for routing and hiding wires and cables; can be specified in Black (P) or Platinum (TI) finish.

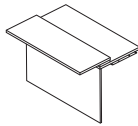

Reception Return with 32'H Transaction Counter 48 ¹ / ₄ "W x 32 ⁷ / ₈ "D x 32"H	HLAM3348RR	145	3.7	\$829	\$35	\$35	N/A
---	-------------------	-----	-----	--------------	-------------	-------------	------------

NOTES: Non-handed. For use with HLAM3772RD and Reception Desk Shell (H105724). Counter facilitates accessibility; measures 48"W x 12"D x 32"H. Flat edge (G) matches 10500 Series™. For beaded (B) and tri-oval (V) edge shapes, the transaction counter is profiled on the approach side, and the return worksurface is profiled on the user's side. All other edges are flat banded. Beaded (B) and tri-oval (V) available in L1 woodgrain colors only. Flat edge (G) available in all woodgrains and solid colors. Pattern laminates do not have matching edge color; patterns can be specified with woodgrain or solid edge. Vertical grain on approach side, end panel, worksurface, and transaction counter. Assembly required.

Specify: Model.Edge Profile & EdgeColor.Worksurface & Counter Color.Chassis Color

SPECIFYING EXAMPLE: HLAM3348RR.GN.N.N

HOW TO SPECIFY

Select Model Number H L A M 3 7 7 2 R D .	Select Edge Profile and Edge Color See page 237 G N .	Select Grommet Color P Black TI Platinum Not specified for model HLAM3348RR P .	Select Worksurface Laminate See page 236 N .	Select Chassis Laminate See page 236 N .	Select Accent Panel Laminate See page 236 Not specified for model HLAM3348RR L D W 1
---	--	--	---	---	--

10500 SERIES™

Shared Components & Accessories

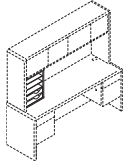

Not available in two-tone laminate



DESCRIPTION	MODEL	SHIP WEIGHT	CUBE	LIST PRICE BY LAMINATE GRADE	
				L1	L2
Vertical Paper Manager 14 ⁷ / ₈ "W x 10 ⁷ / ₈ "D x 19 ³ / ₈ "H NOTES: Keeps papers, files, and books neatly organized and within easy reach from a seated position. Designed for desk, credenza, and return tops. Fits under stack-on storage models. Two pullout drawers and three fixed shelves. Unit can also be used with 10700 Series™, Valido®, and 94000 Series™. When used in conjunction with wall mounted storage cabinets, the top of the wall mounted storage cabinets must be positioned a minimum of 68" above the floor. For additional information see the Workplace Tools section in the 2021 Shared Spaces Pricer. SPECIFYING EXAMPLE: HLVP1.N	HLVP1	27	2.8	\$327	\$337

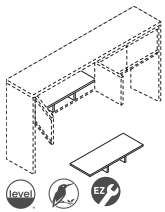

DESCRIPTION	MODEL	SHIP WEIGHT	CUBE	LIST PRICE
Stacked Paper Management 32 ¹ / ₂ "W x 12 ⁵ / ₈ "D x 4 ¹ / ₄ "H NOTES: Segments and organizes stack-on and wall mount storage compartments, as well as bookcase shelves. In some cases, installation may require removing the stack-on or wall mount storage doors. For additional information see the Workplace Tools section in the 2021 Shared Spaces Pricer. ! Black only.	HLVPM2	22	1.25	\$163



Not available in two-tone laminate



DESCRIPTION	MODEL	SHIP WEIGHT	CUBE	LIST PRICE BY LAMINATE GRADE	
				L1	L2
Desktop Storage Terrace 26 ¹ / ₂ "W x 12 ¹ / ₂ "D x 10 ¹ / ₂ "H NOTES: Keeps work-in-process, priority files, loose pages, and mail neatly organized and in view. Mixed material design comprised of sturdy laminate shelves with metal back and support panels. Not available in two-tone laminate combination or pattern laminate colors. Choose from Platinum Metallic (T1), Black (P), and Charcoal (S) for the metal components. Sized to fit in stack-on and wall mounted storage cabinets in 10500, 10700, Valido, 94000, and 38000 Series. Fits in Voi stack-on and overhead cabinets except for 48"W or smaller sliding door models. For additional information see the Workplace Tools section in the 2021 Shared Spaces Pricer. Specify: Model.Laminate.Paint SPECIFYING EXAMPLE: HLDST1.N.T1	HLDST1	24	1.1	\$306	\$316



Refer to page 106 for Center Drawer compatibility information

DESCRIPTION	MODEL	SHIP WEIGHT	CUBE	L1	L2
				LIST PRICE	LIST PRICE
Angled Wood Center Drawer 26" x 15 ³ / ₈ " 22" x 15 ³ / ₈ " NOTES: Specify laminate for drawer. Model H1522 can be used on peninsulas with modesty panel, model H10528. For additional information see the Workplace Tools section in the 2021 Shared Spaces Pricer.	H1526	12	1.2	\$198	\$213
	H1522	11	1.1	\$184	\$199

NOTES:

- For 10500 Series™ matching Occasional Tables, see page 291.
- Vertical paper manager designed for desk, credenza, and return tops. Fits under stack-on storage.
- Stacked paper management segments and organizes stack-on and wall mount storage compartments, as well as bookcase shelves. Unit can be used in models H105327, H10534, H105322, H105321, H105382 and H105381.
- Desktop Storage Terrace is for use on the tops of 29¹/₂"H desks, credenzas, and returns.
- Desktop Storage Terrace features six storage sections plus top display shelf.
- Desktop Storage Terrace includes protective, non-slip pads on the base.
- See pages 268-295 for shared components.

! In some cases, installation of Stacked Paper Management may require removing the stack-on or wall mount storage doors.

HOW TO SPECIFY

Select Model Number HLVP1.N	Select Laminate See pages 236-237 N
---------------------------------------	--

10500 SERIES™

Shared Components & Accessories

GSA SIN 33721

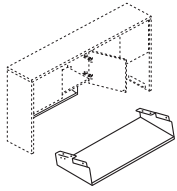

Icon Legend on page 19

**DESCRIPTION****Hanging Paper Shelf**28¹/₁₆"W x 11⁷/₁₆"D x 4³/₁₆"H**MODEL****HHPS1****SHIP WEIGHT**

7

CUBE

2.9

LIST PRICE**\$198**

NOTES: Maximizes worksurface space; de-clutters desktop while placing priority communications and active project folders within easy reach. Angled design allows contents to be distinguished at a glance. Mixed material styling features strong painted metal frame with a frosted shelf.

Attaches quickly and easily to stack-on and wall mount storage models in the following series: 10500, 10700, Valido, 94000, and Voi (except the 36"W overhead hutch with O-legs or panel mount brackets). Not for use with 38000 Series.

For additional information see the Workplace Tools section in the 2021 Shared Spaces Pricer.

Specify: Model.Paint

SPECIFYING EXAMPLE: HHPS1.T1

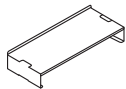
**Desktop Paper Shelf**28¹/₁₆"W x 11⁵/₁₆"D x 5"H**HDPS1**

7

2.9

\$198

NOTES: Organizer shelf provides a place and space for work-in-process and piling to keep worksurfaces neat and tidy. Convenient, scalable design with interlocking side supports allow two units to be stacked and integrated. Durable painted metal frame with a frosted shelf; mixed material styling matches hanging paper shelf.

Can also be used inside select overhead storage, including the following stack-on with hinged door models: 10500 and Valido 36", 42", 66", 72", 78"W and 10700 68⁵/₁₆"W.

For additional information see the Workplace Tools section in the 2021 Shared Spaces Pricer.

Specify: Model.Paint

SPECIFYING EXAMPLE: HDPS1.T1

**Storage Cube**

12"W x 12"D

HLSL1212

1

0.3

\$294

SPECIFYING EXAMPLE: HLSL1212.P8S

**NOTES:**

- For 10500 Series™ matching Occasional Tables, see page 291.
- Desktop Paper Shelf includes protective, non-slip pads on the base.
- Paper Shelf can stack two-high.
- Hanging Paper Shelf attaches quickly and easily (screws included).
- See pages 268-295 for shared components.
- For additional information see the Workplace Tools section in the 2021 Shared Spaces Pricer.

HOW TO SPECIFY

Select Model Number	Select Paint Color
	See page 173
HHPS1.	T1



10500 Series™ Laminate Occasional Tables

	DESCRIPTION	MODEL	SHIP WEIGHT	CUBE	LIST PRICE
	Coffee Table 48"W x 20"D x 16"H	H80191	48	3.4	\$486
	Corner Table 24"W x 24"D x 20"H	H80192	35	2.1	\$419
	End Table 24"W x 20"D x 20"H	H80193	29	1.8	\$400

Laminate Occasional Tables (H80191, H80192 and H80193)

Woodgrain	Solid	Patterned	Two-Tone	
Bourbon Cherry (HH) Cognac (COGNCOGN) Florence Walnut (LFWILFW1) Harvest (CC) Kingswood Walnut (LK1ILK1I) Mahogany (NN) Mocha (MOCHMOCH) Natural Maple (DD) Pinnacle (PINCPINC) Shaker Cherry (FF) Sterling Ash (LSA1LSA1)	Black (PP) Charcoal (SS) Designer White (LDWILDW1) Loft (LOFTLOFT)	Canyon Zephyr (K9) Desert Zephyr (K8) Grey Tigris (L6*) Sheer Mesh (A5) Silver Mesh (B9) *Select edge/apron/leg color Black (P) Bourbon Cherry (H) Charcoal (S) Cognac (COGN) Designer White (LDW1) Florence Walnut (LFW1) Harvest (C) Kingswood Walnut (LK1I) Mahogany (N) Mocha (MOCH) Natural Maple (D) Pinnacle (PINC) Shaker Cherry (F) Sterling Ash (LSA1)	Black/Charcoal (PS) Black/Designer White (PLDW1) Bourbon Cherry/Black (HP) Bourbon Cherry/Charcoal (HS) Bourbon Cherry/Designer White (HLDW1) Charcoal/Black (SP) Charcoal/Designer White (SLDW1) Cognac/Black (COGNP) Cognac/Charcoal (COGNS) Cognac/Designer White (COGNLDW1) Designer White/Black (LDW1P) Designer White/Bourbon Cherry (LDWIH) Designer White/Charcoal (LDW1S) Designer White/Cognac (LDWICOGN) Designer White/Florence Walnut (LDWILFW1) Designer White/Harvest (LDW1C) Designer White/Kingswood Walnut (LDWILK1I) Designer White/Mahogany (LDWIN) Designer White/Mocha (LDW1MOCH) Designer White/Natural Maple (LDW1D) Designer White/Pinnacle (LDW1PINC) Designer White/Sterling Ash (LDW1LSA1)	Designer White/Shaker Cherry (LDW1F) Florence Walnut/Black (LFW1P) Florence Walnut/Charcoal (LFW1S) Florence Walnut/Designer White (LFWILDW1) Florence Walnut/Loft (LFWILOFT) Harvest/Black (CP) Harvest/Charcoal (CS) Harvest/Designer White (CLDW1) Kingswood Walnut/Black (LK1IP) Kingswood Walnut/Charcoal (LK1IS) Kingswood Walnut/Designer White (LK1ILDW1) Kingswood Walnut/Loft (LK1ILOFT) Mahogany/Black (NP) Mahogany/Charcoal (NS) Mahogany/Designer White (NLDW1) Mocha/Black (MOCHP) Mocha/Charcoal (MOCHS) Mocha/Designer White (MOCHLDW1) Natural Maple/Black (DP) Natural Maple/Charcoal (DS) Natural Maple/Designer White (DLDW1) Pinnacle/Black (PINCP) Pinnacle/Charcoal (PINCS) Pinnacle/Designer White (PINCLDW1) Shaker Cherry/Black (FP) Shaker Cherry/Charcoal (FS) Shaker Cherry/Designer White (FLDW1) Sterling Ash/Black (LSA1P) Sterling Ash/Charcoal (LSA1S) Sterling Ash/Designer White (LSA1LDW1)

NOTES:

- Durable material and construction make laminate occasional tables ideal for high traffic areas such as lobbies, reception rooms and lounges. Versatile design is also well suited to private offices.
- Tables accommodate lamps, magazines, telephones, plants, laptops and more.
- Coffee, Corner and End Tables feature top-over-apron styling with square corner detail, which complements many interiors and furniture designs.
- Tops are abrasion- and stain-resistant laminate over 1/8" thick solid core high-performance particleboard.
- For 10500 Series™ mobile tables, see page 269.
- See pages 268-295 for shared components.

HOW TO SPECIFY

Select Model Number <input type="text" value="H80191"/>	Select Laminate See above <input type="text" value="NN"/>
<input type="text" value="H80191"/>	<input type="text" value="L6N"/>

10500 Series™

Shared Components & Accessories

GSA SIN 33721

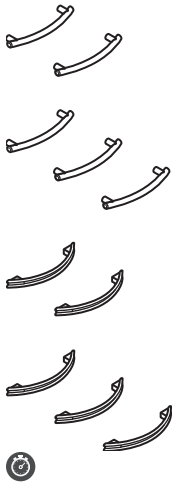

Icon Legend on page 19

**DESCRIPTION****Field Installable Drawer/Door Handle Kits**

Sweep Black, 2-pack
Sweep Satin Nickel, 2-pack

MODEL

HSWEEPA2
HSWEEPC2

SHIP WEIGHT

0.4
0.4

CUBE

0.3
0.3

LIST PRICE

\$43
\$43

Sweep Black, 3-pack
Sweep Satin Nickel, 3-pack

HSWEEPA3
HSWEEPC3

0.5
0.5

0.3
0.3

\$56
\$56

Crescent Black, 2-pack
Crescent Satin Nickel, 2-pack

HCRESCENTA2
HCRESCENTC2

0.4
0.4

0.3
0.3

\$43
\$43

Crescent Black, 3-pack
Crescent Satin Nickel, 3-pack

HCRESCENTA3
HCRESCENTC3

0.5
0.5

0.3
0.3

\$56
\$56

NOTES: Handles are for purchase and field installation on 10500 or 10700 Series™ desks, credenzas, returns, and lateral files, as well as for the modular pedestals used with 10700 and 10500.

Applications include:

- box/file and file/file pedestals = one 2-pack per pedestal
- box/box/file and pencil/media/file pedestals = one 3-pack per pedestal
- two drawer lateral file = two 2-packs per unit
- four drawer lateral file = four 2-packs per unit

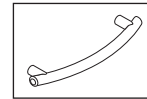
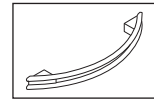
**Sweep Handle****Crescent Handle**

The hole spacing for the Sweep and Crescent handles is 96mm (approx. 3¾"). Important note: effective January 1, 2007, the holes used for the black drawer/door handle that comes standard on several HON 10500 and 10700 Series™ products, including mobile pedestals, storage cabinet with doors, storage/file cabinet, storage cabinet/lateral file, personal wardrobe/storage cabinets, and personal storage towers, will accept the Sweep and Crescent handles. Units manufactured prior to January 1, 2007, have 64mm (approx. 2½") hole spacing and will not accept the Sweep and Crescent handles. Instructions include mounting hardware and paper template.

! Must be ordered with a configurable end product. If ordered separately, not on GSA contract.

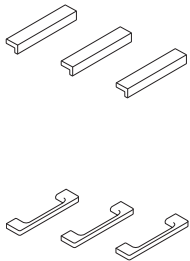
**Field Installable Drawer/Door Handle Kits**

Linear, Black, 2-pack
Linear, Matte Chrome, 2-pack

HLINEARA2
HLINEARC2

0.4
0.4

0.3
0.3

\$56
\$56

Linear, Black, 3-pack
Linear, Matte Chrome, 3-pack

HLINEARA3
HLINEARC3

0.5
0.5

0.3
0.3

\$64
\$64

Specify Linear handles in black to coordinate with 10500 Series™ models that ship standard with a decorative handle, such as mobile pedestals, storage cabinets and wardrobes.

Arch, Black, 2-pack
Arch, Matte Chrome, 2-pack

HARCHA2
HARCHC2

0.4
0.4

0.3
0.3

\$56
\$56

Arch, Black, 3-pack
Arch, Matte Chrome, 3-pack

HARCHA3
HARCHC3

0.5
0.5

0.3
0.3

\$64
\$64

NOTES: Handles are for purchase and field installation on 10500 or 10700 Series™ desks, credenzas, returns, lateral files and modular pedestals. Instructions include mounting hardware and paper template for drilling holes.

Applications include:

- box/file and file/file pedestals = one 2-pack per pedestal
- box/box/file and pencil/media/file pedestals = one 3-pack per pedestal
- two drawer lateral file = two 2-packs per unit
- four drawer lateral file = four 2-packs per unit

The Linear and Arch handles can be attached using 96mm (approx. 3¾") or 128mm (approx. 5") hole spacing. Important note: effective January 1, 2007, the holes used for the black drawer/door handle that comes standard on several HON 10500 and 10700 Series™ products, including mobile pedestals, storage cabinet with doors, storage/file cabinet, storage cabinet/lateral file, personal wardrobe/storage cabinets, and personal storage towers, will accept the Linear and Arch handles. Units manufactured prior to January 1, 2007, have 64mm (approx. 2½") hole spacing and will not accept the Linear and Arch handles.

! Must be ordered with a configurable end product. If ordered separately, not on GSA contract.

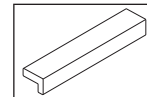
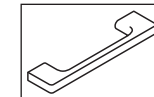
**Linear Handle****Arch Handle****NOTES:**

- Field Installable Drawer/Door Handle Kits for use on 10500 Series™ desks, credenzas, returns and lateral files.
- A metal template is available to facilitate field installation of the Linear, Arch, Sweep and Crescent decorative handles on 10500 and 10700 Series™ drawer fronts; order model SPLH-SYST-DRKNB.M263164.
- See pages 268-295 for shared components.

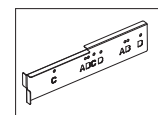
**Metal Template****HOW TO SPECIFY**







Select
Model Number

H S W E E P A 2

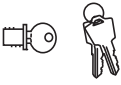

Icon Legend on page 19

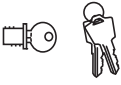
10500 SERIES™ Shared Components & Accessories

	DESCRIPTION	MODEL	SHIP WEIGHT	CUBE	LIST PRICE
 SIN 33721 	Black Removable Lock Core Kit	HF23B	0.1 	0.1	\$32
	Satin Removable Lock Core Kit	HF23S	0.1 	0.1	\$42
	<ul style="list-style-type: none"> Specify quantity of each key number from 101E-225E. Includes: 1-core, 2-keys, 1-core removal tool, and instructions. <p>NOTES: Lock with a removable cylinder that can be interchanged as needed; allows users to access all furniture pieces in an office with a single key for convenience and security. Makes re-keying quick and easy. For use in all 10500 Series™ product lock cores, except the stack-on and wall mounted storage “K” models. For the latter use model HF27B or HF27S, listed below.</p>				
 	Removable Lock Core Kit				
	Black HF27B 0.2 0.02 \$32 Satin HF27S 0.2 0.02 \$32				
	<ul style="list-style-type: none"> For stack-on and wall mounted storage laminate models (with locks) in 10500, 10700, Valido, Voi, Concinnity, and 94000 Series. Specify quantity of each key number from 101E to 225E. Includes: 1-core, 2-keys, 1-core removal tool, and instructions. <p>NOTES: If key number isn't specified, number will be at random.</p>				

NOTES:

- See pages 268-295 for shared components.
- For master key, see model HF22 on page 746.

HOW TO ORDER CORE REMOVABLE LOCK KITS:





Specify: Model Number.X
Key Number

Examples: HF23S.X121E
HF23S.X (Key number not specified)

NOTES: Key orders without numbers specified will be keyed at random.
Numbers 101E-225E are available.

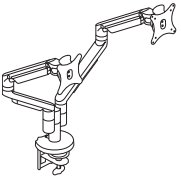
SAMPLE ORDER:

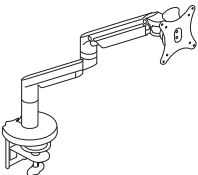
Quantity	Model	Key Code
4	HF23B.	X121E

	DESCRIPTION	MODEL	SHIP WEIGHT	CUBE	LIST PRICE
	Dual Dynamic Monitor Arm	HMASD	17.0 	1.1	\$900
	<ul style="list-style-type: none"> 150° of rotation at base with optional 360° rotation. Arms extend 22" and retract up to 3". Monitor mount rotates 180° and tilts +/-30°. Monitor can be rotated from landscape to portrait position. <p> Arms hold monitors from 6.2-18 lbs. Optional counterweight HPACW available to support monitors as low as 5 lbs. (see the Workplace Tools section in the 2021 Shared Spaces Pricer).</p>				
	Single Dynamic Monitor Arm	HMASTS	11.5 	0.8	\$468
	<ul style="list-style-type: none"> 180° of rotation at base with optional 360° rotation. Arms extend 22" and retract up to 3". Monitor mount rotates 180° and tilts +/-30°. Monitor can be rotated from landscape to portrait position. <p> Arms hold monitors from 6.2-18 lbs. Optional counterweight HPACW available to support monitors as low as 5 lbs. (see the Workplace Tools section in the 2021 Shared Spaces Pricer).</p>				

HOW TO SPECIFY

<p>Select Model Number</p>	<p>Select Finish</p> <p><i>Specify for models HMASD and HMASTS only</i></p> <p>SVR Silver BLK Black</p>
<p>HMASD.</p>	<p>SVR</p>

10500 Series™

Shared Components & Accessories

GSA SIN 33721T EXCEPT AS NOTED

ABI

Icon Legend on page 19



SIN 33721

DESCRIPTION**Field Installable Grommet**

- Intended for use in tops and end panels to route/hide cords and in modesty panels to facilitate reaching wall electrical outlets.
- Grommet is field installable.
- Grommet shape is round.
- Includes grommet cap and sleeve.
- Grommet cap measures 3" diameter and includes a 3/4" diameter cord access hole.
- Grommet sleeve measures 2 1/2" O.D. x 3/4" thick.
- Includes instructions to locate grommet position for desks, credenzas, returns and bridges.

NOTES: For additional information see the Workplace Tools section in the 2021 Shared Spaces Pricer.

! Black Finish

! Requires a 2 1/2" diameter hole saw and drill for installation (not included).

MODEL**HFLDGRMT****SHIP WEIGHT**

0.1 Ⓢ

CUBE

0.01

LIST PRICE**\$32**

SIN 33721

Field Installable Grommet

- Intended for use in tops and end panels to route/hide cords and in modesty panels to facilitate reaching wall electrical outlets.
- Grommet is field installable.
- Grommet shape is round.
- Includes grommet cap and sleeve.
- Grommet outside dimensions measure 3 1/2" diameter and includes two cord access holes.
- Grommet sleeve measures 3" O.D. x 1" thick.
- Includes instructions to locate grommet position for desks, credenzas, returns and bridges.

NOTES: For additional information see the Workplace Tools section in the 2021 Shared Spaces Pricer.

! Black Finish

! Requires a 3" diameter hole saw and drill for installation (not included).

HFLDGRMT3

0.1 Ⓢ

0.3

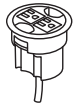
\$32**Power Hub, 3" Grommet Mount, 6' Cord**

- Brings the ease of plug-and-play to the desktop.
- Fits in 3" round grommet holes in 10500 Series™ desks, credenzas and returns; not compatible with 10500 Series™ 2 1/2" round grommets.
- Two grounded AC power outlets.
- Two cord pass-through holes in cap.
- Includes 6' cord with three-prong plug.
- For field installation.
- UL Listed.

NOTES: For additional information see the Workplace Tools section in the 2021 Shared Spaces Pricer.

! Available in Black only (no color designation - Specify: HGRMTAC.X).

HGRMTAC

1.3

0.2

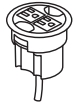
\$116**3" Round Power Grommet - 2 Outlets, 10' Cord**

- Includes 10' cord with three-prong plug.
- Fits in 3" round grommet holes on the following product lines: Coordinate, Huddle, Motivate, all laminate and veneer casegoods series, and Systems Worksurfaces.
- Two grounded AC power outlets.
- Field installed with Plug-and-play ease.

NOTES: Power Modules will also work with standing-height applications for 10500 Series™ and Voi® desks. Optional Memory Control allows preset worksurface heights for consistency. Ships separately. Dynamic load capacity when worksurface is moving is 300 lbs.

! Available in black finish only, no specification needed.

HGRMTAC2

1.5

0.2

\$148**Power/USB Hub, 3" Grommet Mount**

- Brings the ease of plug-and-play to the desktop.
- Fits in 3" round grommet holes in 10500 Series™ desks, credenzas and returns; not compatible with 10500 Series™ 2 1/2" round grommets.
- One grounded AC power outlet with 2 USB ports.
- Two cord pass-through holes in cap.
- Includes 6' cord with three-prong plug.
- For field installation.
- UL Listed.

NOTES: For additional information see the Workplace Tools section in the 2021 Shared Spaces Pricer.

! Available in black only (no color designation so use .X - Specify: HGRMTUSB2.X).

HGRMTUSB2

1.3 Ⓢ

0.02

\$226**NOTES:**

- See pages 268-295 for shared components.

HOW TO SPECIFYSelect
Model Number

H F L D G R M T



Icon Legend on page 19

10500 SERIES™ Shared Components & Accessories



SIN 33721

DESCRIPTION

Articulating Desk Lamp
Articulating Desk Lamp w/ Occupancy Sensor

MODEL **SHIP WEIGHT** **CUBE** **LIST PRICE**

HLED1 1.2 Ⓢ 6.5 **\$402**
HLED10C 1.2 Ⓢ 6.5 **\$490**

NOTES: For additional information see the Workplace Tools section in the 2021 Shared Spaces Pricer.

! Silver finish only, no specification needed.



SIN 33721

Task Desk Lamp

HLED2 0.7 Ⓢ 3.0 **\$348**

NOTES: For additional information see the Workplace Tools section in the 2021 Shared Spaces Pricer.

! Brushed nickel finish only, no specification needed.

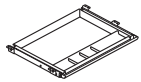

OPEN MARKET

Polymer Center Drawer

HCD1 7.0 0.5 **\$111**

- Color: Black.
- Material: ABS.
- Minimum clearance for mounting: 23"W x 16¼"D x 2"H.
- Retracts on 16" ball-bearing slides.
- Can be used on worksurfaces with Coordinate™ Height Adjustable Bases as long as it is attached with spacer model HKBS.
- Can store up to 25 lbs.

! Black finish only, no specification needed.

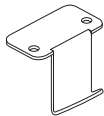

OPEN MARKET

Back Pack Hook (10 per carton)

12"W x 14½"D x 1½"H

HCLA65 10.0 Ⓢ 0.1 **\$95**

NOTES: Assembly: attaches to bottom of desk with (2) screws, included.

! Available in Platinum Metallic finish only, no specification needed.



DESCRIPTION

MODEL

SHIP WEIGHT **CUBE**

LIST PRICE BY PAINT GRADE
P1 **P2**



Slide-Away Keyboard Platform (Specify: Laminate) **H4022**

10 Ⓢ 0.6 **\$213**

Extended Tray Slide-Away Keyboard Platform **HE4022**

12 Ⓢ 0.7 **\$302**

(Specify: Laminate)

Metal Keyboard and Mouse Tray (Specify paint) **H4028 OPEN MARKET**

11 Ⓢ 1.5 **\$153** **\$163**

Metal Keyboard Tray (Specify paint) **H4029 OPEN MARKET**

11 Ⓢ 1.5 **\$138** **\$148**

NOTES: For additional information see the Workplace Tools section in the 2021 Shared Spaces Pricer.

Refer to the Workplace Tools section in the 2021 Shared Spaces Pricer for additional product information

SIN 33721



NOTES:

- See pages 268-295 for shared components.

HOW TO SPECIFY

Select Model Number

H L E D 1

10500 SERIES™

Accessories

OPEN MARKET

Icon Legend on page 19

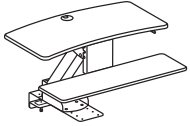
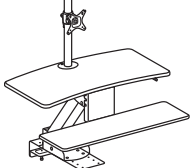
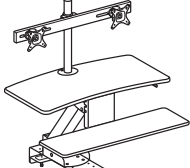
	DESCRIPTION	MODEL	SHIP WEIGHT	CUBE	LIST PRICE
	Coordinate™ Portable Desktop Riser 31"D x 5"-16½"H x 35"W NOTES: Available in Black (BLK) or White (WHT) finish. Desktop riser dimensions (without keyboard tray): 22"D x 5"-16½"H x 35"W. Keyboard tray dimensions: 9"D x 30"W. Max loading capacity is 33 lbs for the desktop riser surface and 4 lbs for the keyboard tray. Easily transition from seated to standing positions throughout the workday. Sits atop an existing desk to create sit-to-stand functionality by raising the computer. Includes keyboard tray and surface for computer monitors. HON 5-Year Limited Warranty. ⓘ Not intended for use on mobile workstations.	HBXRISER	54.0	4.1	\$619
	Dual Monitor Arm with 2 USB Ports NOTES: Easy adjustment. Height adjusts to 17" tall. Monitor tilt and swivel capability. Enclosed cable management. Grommet or desktop mounting. Clean appearance. In some applications the Monitor Arms may extend 12 or more inches into the worksurface. For additional information see the Workplace Tools section in the 2021 Shared Spaces Pricer. HON 5-Year Limited Warranty. ⓘ No specification needed.	HBDMAUSB	41.9	2.6	\$383
	Coordinate™ Mounted Desktop Riser NOTES: Does not include a monitor arm and is suitable for laptops and/or monitors on their original stands. ⓘ No specification needed.	HS1100	60.0 ⓘ	3.2	\$664
	Coordinate™ Mounted Desktop Riser with Single Monitor Arm NOTES: Includes a monitor arm for a single monitor. ⓘ No specification needed.	HS1101	62.0 ⓘ	3.2	\$777
	Coordinate™ Mounted Desktop Riser with Dual Monitor Arm NOTES: Includes a monitor arm for dual monitors. ⓘ No specification needed.	HS1102	63.0 ⓘ	3.2	\$883

NOTES FOR HS1100, HS1101, HS1102:

- These products are designed to allow the user to transition from seating position to standing position throughout the workday.
- Gas-assist lever-operated mechanism with positive stop.
- Clamp mount compatible with worksurfaces depths of 20"-30". 20" is for systems only.
- Clamp requires 3.5" of clearance along back edge of worksurface.
- Black seamless worksurfaces.
- Silver powder coated metal components.
- Lowers below worksurface level on 24" and 30"D worksurfaces.
- All models contain a large primary worksurface and a smaller keyboard / mouse surface.
- Beveled edges for sleek appearance and comfort while typing.
- Monitor arms include height, width, and swivel adjustment.

- Not for use under overhead storage, with flush mounted modesty panels, or worksurfaces thinner than 1".

- ⓘ Not recommended for use on mobile (castered) worksurfaces.

MOUNTING AND COMPATIBILITY FOR HS1100, HS1101, HS1102:

- This product is intended to be installed on commercial-grade worksurfaces in good condition.
- Compatible with freestanding worksurfaces 24"-30"D or panel-supported worksurfaces 24"-30"D.
- Not for use on mobile worksurfaces.

Clamp Mount

Use when 3.5" minimum overhang is available

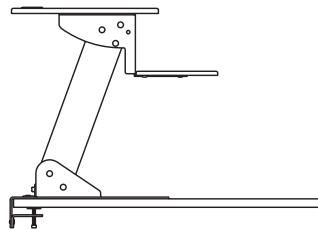

Screw Mount

Use when no overhang is available. Worksurface must be minimum 1" thick.

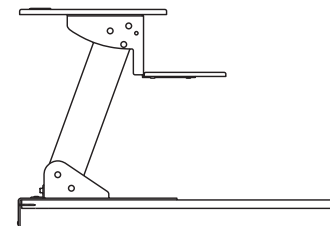

HOW TO SPECIFY

Select Model Number



HBXRISER.

Select Finish

BLK Black
WHT White

BLK

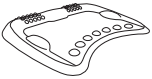
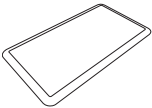
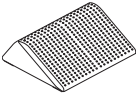

	DESCRIPTION	MODEL	SHIP WEIGHT	CUBE	LIST PRICE
	Rectangle Wobble Board — Anti-Fatigue Mat 18"D x 3"H x 22½"W ⓘ Available in Black (T) finish ONLY. Recommended weight capacity not to exceed 250 pounds. HON 5-Year Limited Warranty. SPECIFYING EXAMPLE: HVL981.T	HVL981 Ⓢ	10.0 Ⓢ	0.9	\$121
	Round Wobble Board — Anti-Fatigue Mat 18½"D x 2⅝"H x 18½"W ⓘ Available in Black (T) finish ONLY. Recommended weight capacity not to exceed 250 pounds. HON 5-Year Limited Warranty. SPECIFYING EXAMPLE: HVL982.T	HVL982 Ⓢ	5.8 Ⓢ	0.6	\$103
	Ergonomic Anti-Fatigue Mat 25"D x 2¾"H x 29⅞"W ⓘ Available in Black ONLY. No specification needed. SPECIFYING EXAMPLE: HBEAFM1	HBEAFM1	7.0	1.4	\$219
	Rectangle Anti-Fatigue Mat 20"D x ¾"H x 36"W ⓘ Available in Black ONLY. No specification needed. SPECIFYING EXAMPLE: HBAFM2036	HBAFM2036 Ⓢ	5.4	0.4	\$100
	Footrest — Anti-Slip Cover 13¾"D x 5½"H x 16"W ⓘ Available in Black (T) finish ONLY. Recommended weight capacity not to exceed 250 pounds. HON 5-Year Limited Warranty. SPECIFYING EXAMPLE: HVL991.T	HVL991	7.0 Ⓢ	0.9	\$82

NOTES:

Ⓢ Discontinued 1/1/21.

HOW TO SPECIFY

Select Model Number	Select Finish
H V L 9 8 1 .	T Black
	T

10700 SERIES™



10700 Series™ Teaming Workstations shown with Ignition® and Flock® Seating.

10700 SERIES™

Talk about a high achiever! The versatile 10700 Series offers a wide selection of layout configurations — making it easy to get the clean, cohesive look your office needs. Designed to withstand frequent moving and reconfiguration, the 10700 Series boasts contract grade high-pressure laminate and a durable inner-frame construction. Whatever the look you go for, this all-around performer is a smart choice.



FEATURES

- Contoured, solid wood accents and waterfall-shaped edges combine form and function for lasting comfort.
- Make the most of both large and small spaces with flexible storage options that work well together.
- With a variety of mixed materials to choose from, you can customize your look to perfectly match your aesthetic.
- Available in eight woodgrain patterns, our laminate desks are the definition of scratch-, spill- and stain-resistant durability.

10700 SERIES™ ORDERING INFORMATION

LAMINATE FINISHES AVAILABILITY

L1 LAMINATES CODES

Woodgrain

- ◆ Bourbon Cherry HH
- ◆ Cognac **COGNCOGN**
- ◆ Harvest CC
- ◆ Mahogany NN
- ◆ Mocha **MOCHMOCH**
- ◆ Natural Maple DD
- ◆ Pinnacle **PINCPINC**
- ◆ Shaker Cherry FF

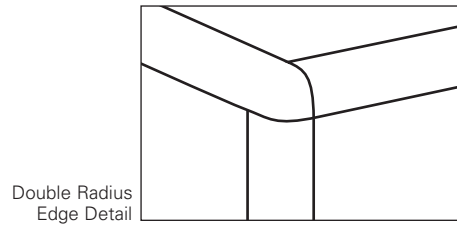

◆◆◆ For lead time information see page 19.

10700 SERIES™

Typicals



Icon Legend on page 19

Components used are listed on pages 306-327. Order components individually. Other configurations are possible, including various sizes of some components.

QTY	DESCRIPTION	MODEL	LIST PRICE	PRICE EXTENSION
1	Double Pedestal Desk – 2/2 60"W x 30"D x 29½"H	H10771	\$1,422	\$1,422
1	Credenza with Kneespace – 2/0/2 60"W x 24"D x 29½"H	H10765	\$1,356	\$1,356
TOTAL:			\$2,778	

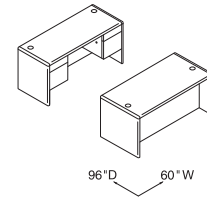

DESK WORKSTATION
60"W x 96"D

QTY	DESCRIPTION	MODEL	LIST PRICE	PRICE EXTENSION
1	Corner Unit 24" x 36" x 36" x 24" x 29½"H	H107811	\$1,245	\$1,245
1	Return, Right – B/F 48"W x 24"D x 29½"H	H10715R	\$942	\$942
1	Return, Left – B/F 48"W x 24"D x 29½"H	H10716L	\$942	\$942
1	Stack-on Storage 44½"W x 14½"D x 37½"H	H107313	\$1,110	\$1,110
TOTAL:			\$4,239	

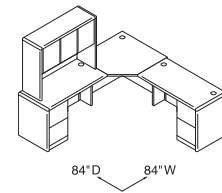

CORNER "L" WORKSTATION
84"W x 84"D

QTY	DESCRIPTION	MODEL	LIST PRICE	PRICE EXTENSION
1	Single Pedestal Desk, Left – B/F 72"W x 36"D x 29½"H	H10786L	\$1,400	\$1,400
1	Bridge 47"W x 24"D x 29½"H	H10770	\$426	\$426
1	Credenza with Lateral, Right 72"W x 24"D x 29½"H	H10747R	\$1,691	\$1,691
1	Stack-on Storage 68½"W x 14½"D x 37½"H	H10734	\$1,259	\$1,259
TOTAL:			\$4,776	

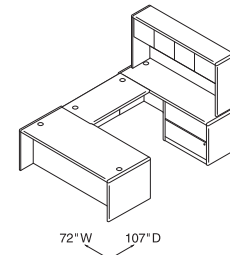

DESK "U" WORKSTATION – RIGHT
72"W x 107"D

QTY	DESCRIPTION	MODEL	LIST PRICE	PRICE EXTENSION
1	Double Pedestal Desk – 3/2 72"W x 36"D x 29½"H	H10799	\$2,164	\$2,164
1	Credenza with Storage 72"W x 24"D x 29½"H	H10742	\$2,164	\$2,164
TOTAL:			\$4,328	

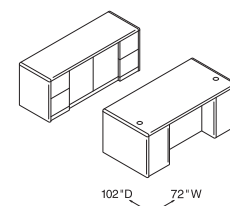

**DESK WORKSTATION WITH
STORAGE CRENDENZA**
72"W x 102"D



Icon Legend on page 19

10700 SERIES™ Typicals

Components used are listed on pages 306-327. Order components individually. Other configurations are possible, including various sizes of some components.

QTY	DESCRIPTION	MODEL	LIST PRICE	PRICE EXTENSION
1	Double Pedestal Desk – 3/2 72"W x 36"D x 29½"H	H10799	\$2,164	\$2,164
1	Credenza with Kneespace – 2/0/2 72"W x 24"D x 29½"H	H10741	\$1,868	\$1,868
1	Stack-on Storage 68⅝"W x 14⅝"D x 37⅞"H	H10734	\$1,259	\$1,259
1	Wardrobe/Storage Cabinet, Right 18"W x 24"D x 66⅝"H	H107295R	\$1,913	\$1,913
TOTAL:			\$7,204	

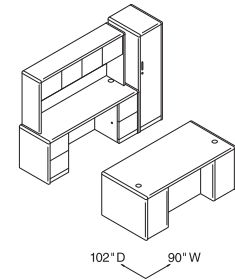

DESK WORKSTATION
90"W x 102"D

QTY	DESCRIPTION	MODEL	LIST PRICE	PRICE EXTENSION
1	Peninsula 72"W x 36"D x 29½"H	H10721	\$1,382	\$1,382
1	Return, Left – F/F 42"W x 24"D x 29½"H	H107192L	\$1,136	\$1,136
1	Stack-on Storage 74⅝"W x 14⅝"D x 37⅞"H	H107318	\$1,382	\$1,382
TOTAL:			\$3,900	

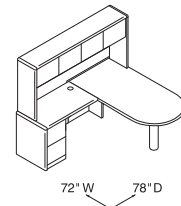

PENINSULA "L" WORKSTATION – LEFT
72"W x 78"D

QTY	DESCRIPTION	MODEL	LIST PRICE	PRICE EXTENSION
1	Single Pedestal Desk, Right – B/B/F 66"W x 30"D x 29½"H	H10701R	\$1,717	\$1,717
1	Return, Left – F/F 48"W x 24"D x 29½"H	H10712L	\$1,149	\$1,149
1	Stack-on Storage 74⅝"W x 14⅝"D x 37⅞"H	H107318	\$1,382	\$1,382
1	2-Drawer Lateral File 36"W x 24"D x 29½"H	H107690	\$1,254	\$1,254
TOTAL:			\$5,502	

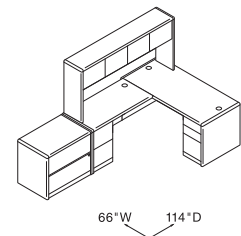

DESK "L" WORKSTATION – LEFT
66"W x 114"D

QTY	DESCRIPTION	MODEL	LIST PRICE	PRICE EXTENSION
1	Peninsula 72"W x 36"D x 29½"H	H10721	\$1,382	\$1,382
1	Bridge 47"W x 24"D x 29½"H	H10770	\$426	\$426
1	Credenza Shell with Full Modesty Panel 72"W x 24"D x 29½"H	H107817	\$941	\$941
1	Multi File Pedestal 36"W x 20"D x 28"H	H10505	\$1,249	\$1,249
1	Stack-on Storage 68⅝"W x 14⅝"D x 37⅞"H	H10734	\$1,259	\$1,259
TOTAL:			\$5,257	

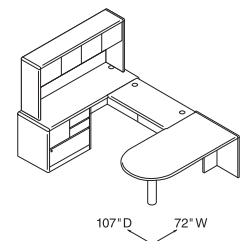

PENINSULA "U" WORKSTATION – LEFT
72"W x 107"D

10700 SERIES™

Typicals



Icon Legend on page 19

Components used are listed on pages 306-327. Order components individually. Other configurations are possible, including various sizes of some components.

QTY	DESCRIPTION	MODEL	LIST PRICE	PRICE EXTENSION
1	Single Pedestal Desk, Left - B/B/F 72"W x 36"D x 29½"H	H10788L	\$1,868	\$1,868
1	Bridge 47"W x 24"D x 29½"H	H10770	\$426	\$426
1	Single Pedestal Credenza, Right - F/F 72"W x 24"D x 29½"H	H10707R	\$1,529	\$1,529
1	Stack-on Storage 68⅝"W x 14⅝"D x 37⅞"H	H10734	\$1,259	\$1,259
1	Wardrobe/Storage Cabinet, Right 18"W x 24"D x 66⅝"H	H107295R	\$1,913	\$1,913
TOTAL:			\$6,995	

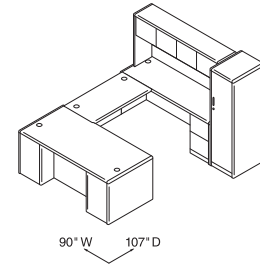

DESK "U" WORKSTATION - RIGHT

90" W x 107" D

QTY	DESCRIPTION	MODEL	LIST PRICE	PRICE EXTENSION
1	Return Shell, Left 36"W x 24"D x 29½"H	H107802L	\$633	\$633
1	Corner Unit 24" x 36" x 36" x 24" x 29½"H	H107811	\$1,245	\$1,245
1	Return Shell, Right 36"W x 24"D x 29½"H	H107801R	\$633	\$633
1	Stack-on Storage 68⅝"W x 14⅝"D x 37⅞"H	H10734	\$1,259	\$1,259
1	Mobile Pedestal - B/B/F 15¾"W x 22¾"D x 28"H	H105102	\$854	\$854
1	Mobile Pedestal - F/F 15¾"W x 22¾"D x 28"H	H105104	\$854	\$854
TOTAL:			\$5,478	

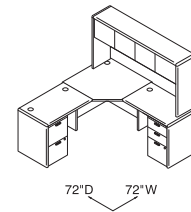

CORNER 6' X 6' WORKSTATION

72" W x 72" D

QTY	DESCRIPTION	MODEL	LIST PRICE	PRICE EXTENSION
1	Desk Shell 66"W x 30"D x 29½"H	H107826	\$1,007	\$1,007
1	Credenza Shell 66"W x 24"D x 29½"H	H107816	\$877	\$877
2	Mobile Pedestal - B/B/F 15¾"W x 22¾"D x 28"H	H105102	\$854	\$1,708
2	Mobile Pedestal - F/F 15¾"W x 22¾"D x 28"H	H105104	\$854	\$1,708
TOTAL:			\$5,300	

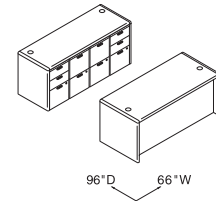

MODULAR DESK AND CREDEZA

66" W x 96" D

QTY	DESCRIPTION	MODEL	LIST PRICE	PRICE EXTENSION
1	Peninsula 66"W x 30"D x 29½"H	H10722	\$1,208	\$1,208
1	Bridge 42"W x 24"D x 29½"H	H10760	\$410	\$410
1	Corner Unit 24" x 36" x 36" x 24" x 29½"H	H107811	\$1,245	\$1,245
1	Return Shell, Right 42"W x 24"D x 29½"H	H107803R	\$633	\$633
1	Mobile Pedestal - B/B/F 15¾"W x 22¾"D x 28"H	H105102	\$854	\$854
1	Mobile Pedestal - F/F 15¾"W x 22¾"D x 28"H	H105104	\$854	\$854
1	Stack-on Storage 74⅝"W x 14⅝"D x 37⅞"H	H107318	\$1,382	\$1,382
TOTAL:			\$6,586	

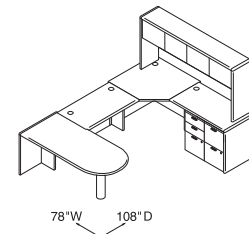

**PENINSULA "U" WITH
MODULAR COMPONENTS**

78" W x 108" D



Icon Legend on page 19

10700 SERIES™ Bundles Typicals

Mahogany H107LL7284N

QTY	DESCRIPTION	MODEL	LIST PRICE	PRICE EXTENSION
1	Left Pedestal Desk	H10786L	\$1,400	\$1,400
1	Right Return	H10715R	\$942	\$942
TOTAL:			\$2,342	

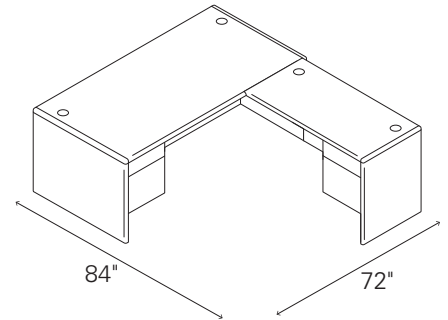

L-STATION (LEFT DESK, RIGHT RETURN)

Mahogany H107LR7284N

QTY	DESCRIPTION	MODEL	LIST PRICE	PRICE EXTENSION
1	Right Pedestal Desk	H10785R	\$1,400	\$1,400
1	Left Return	H10716L	\$942	\$942
TOTAL:			\$2,342	

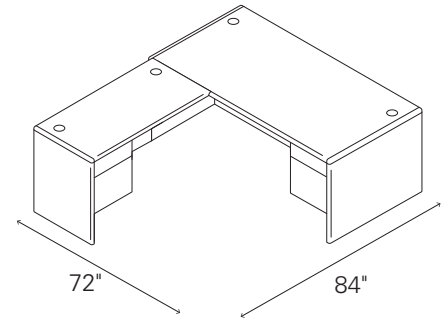

L-STATION (RIGHT DESK, LEFT RETURN)

Mahogany H107UL72108N

QTY	DESCRIPTION	MODEL	LIST PRICE	PRICE EXTENSION
1	Left Pedestal Desk	H10786L	\$1,400	\$1,400
1	Right Pedestal Credenza	H10745R	\$1,228	\$1,228
1	Bridge	H10770	\$426	\$426
TOTAL:			\$3,054	

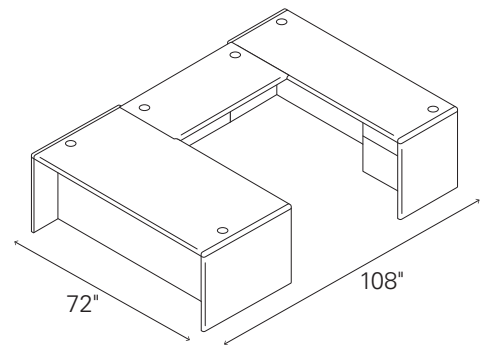

U-STATION (LEFT DESK, RIGHT CREDENZA)

10700 SERIES™ Bundles Typicals



Icon Legend on page 19

Mahogany
H107UR72108N

QTY	DESCRIPTION	MODEL	LIST PRICE	PRICE EXTENSION
1	Right Pedestal Desk	H10785R	\$1,400	\$1,400
1	Left Pedestal Credenza	H10746L	\$1,228	\$1,228
1	Bridge	H10770	\$426	\$426
TOTAL:			\$3,054	

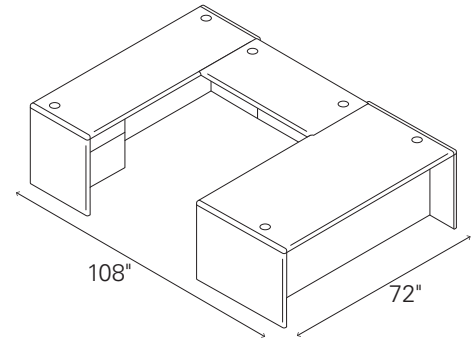

U-STATION (RIGHT DESK, LEFT CREDENZA)

Mahogany
H107LLH7284N

QTY	DESCRIPTION	MODEL	LIST PRICE	PRICE EXTENSION
1	Left Pedestal Desk	H10786L	\$1,400	\$1,400
1	Right Return	H10715R	\$942	\$942
1	Stack-on Storage	H107313	\$1,110	\$1,110
TOTAL:			\$3,452	

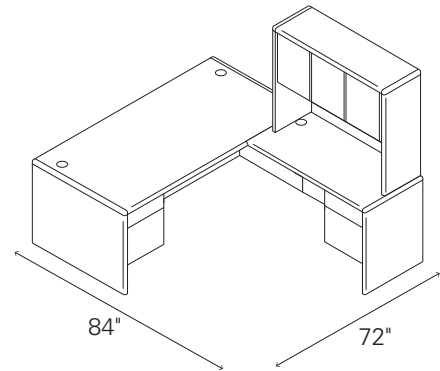

**L-STATION WITH STACK-ON STORAGE
(LEFT DESK, RIGHT RETURN)**

Mahogany
H107LRH7284N

QTY	DESCRIPTION	MODEL	LIST PRICE	PRICE EXTENSION
1	Right Pedestal Desk	H10785R	\$1,400	\$1,400
1	Left Return	H10716L	\$942	\$942
1	Stack-on Storage	H107313	\$1,110	\$1,110
TOTAL:			\$3,452	

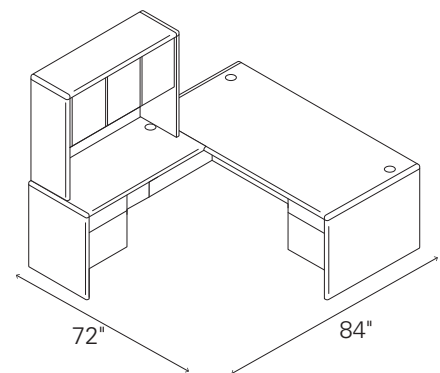

**L-STATION WITH STACK-ON STORAGE
(RIGHT DESK, LEFT RETURN)**



Icon Legend on page 19

10700 SERIES™ Bundles Typicals

DESKS

Mahogany
H107ULH72108N

QTY	DESCRIPTION	MODEL	LIST PRICE	PRICE EXTENSION
1	Left Pedestal Desk	H10786L	\$1,400	\$1,400
1	Right Pedestal Credenza	H10745R	\$1,228	\$1,228
1	Bridge	H10770	\$426	\$426
1	Stack-on Storage	H10734	\$1,259	\$1,259
TOTAL:			\$4,313	\$4,313

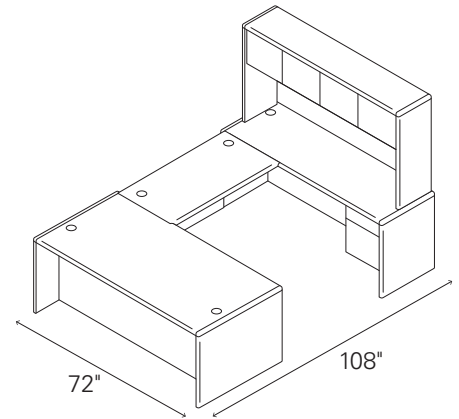

**U-STATION WITH STACK-ON STORAGE
(LEFT DESK, RIGHT CREDENZA)**

Mahogany
H107URH72108N

QTY	DESCRIPTION	MODEL	LIST PRICE	PRICE EXTENSION
1	Right Pedestal Desk	H10785R	\$1,400	\$1,400
1	Left Pedestal Credenza	H10746L	\$1,228	\$1,228
1	Bridge	H10770	\$426	\$426
1	Stack-on Storage	H10734	\$1,259	\$1,259
TOTAL:			\$4,313	\$4,313

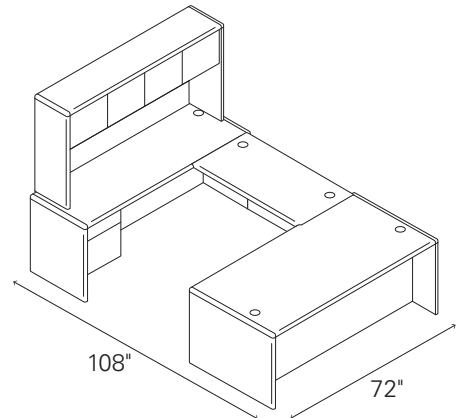

**U-STATION WITH STACK-ON STORAGE
(RIGHT DESK, LEFT CREDENZA)**

10700 SERIES™ Laminate Modular Components

GSA SIN 33721



Icon Legend on page 19

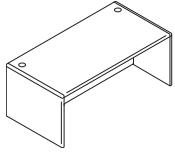

DESCRIPTION	INSIDE DIMENSIONS	FULL WIDTH OVERHANG	MODEL	SHIP WEIGHT	CUBE	LIST PRICE
Desk Shell w/Full Modesty Panel						
72"W x 36"D x 29½"H	69½"W x 24⅝"D	10½"	H107827	213	7.0	\$1138
72"W x 30"D x 29½"H	69½"W x 24⅝"D	4½"	H107829	167	4.7	\$1011
66"W x 30"D x 29½"H	63½"W x 24⅝"D	4½"	H107826	175	5.5	\$1007
60"W x 30"D x 29½"H	57½"W x 24⅝"D	4½"	H107825	164	5.0	\$872
48"W x 30"D x 29½"H	45½"W x 24⅝"D	4½"	H107824	143	5.0	\$847

NOTES: Can be used freestanding or connected to a 42"W return shell to achieve a space efficient 6' x 6' L-shaped workstation layout. Accepts stack-on storage models H10734, H10734K or H10734G. See page 326 for optional center drawers.

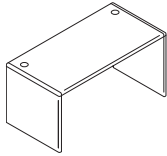

Desk Shell w/10" Modesty Panel						
60"W x 30"D x 29½"H	57½"W x 24⅝"D	4½"	H107825X	161	4.0	\$872

NOTES: Makes reaching wall electrical outlets quick and easy. Provides more than 18" of clearance. Can be used freestanding or connected to a 30"W return shell to achieve a compact 5' x 5' L-shaped workstation layout. Accepts stack-on storage models H10732, H10732K. See page 326 for optional center drawers.

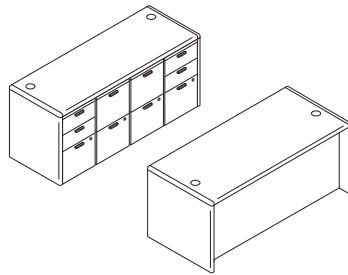

96" D 66" W

- 1 - H107826
- 1 - H107816
- 2 - H105102
- 2 - H105104

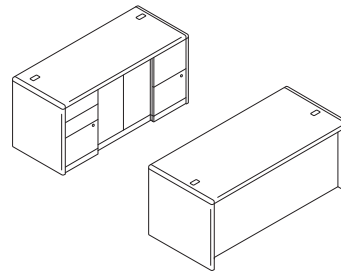

96" D 60" W

- 1 - H107825
- 1 - H107815
- 1 - H10508
- 1 - H10504
- 1 - H10502

! All 10700 Series™ grommets on desk, credenza, credenza shell, return, return shell, bridge and corner unit worksurfaces changed from rectangle-shaped to round, effective November, 2011.

NOTES:

- Desk, credenza, and return shells, combined with a variety of under-the-worksurface storage solutions, maximize office layout flexibility. Products can be reconfigured quickly and easily when user preferences or space needs change.
- Worksurfaces and end panels feature contract-grade scratch, stain and spill resistant laminate over durable 1⅛" solid core high-performance particleboard; resists warping.
- Contoured hardwood trim; stained to match laminate.
- User friendly waterfall-shaped edges and round corners.
- 3" round cord management grommets, for routing and hiding wires and cables, are located in the tops of desk, credenza, and return shells. Grommets also serve as anchor points for stack-on storage and organizers.
- Grommet can be replaced with optional Power Hub or Power/USB Hub for easy plug-and-play. See page 328.
- Shells utilize 10500 Series™ mobile pedestals or modular pedestals. See pages 259-261.
- See pages 310-311 for modular storage components.



HOW TO SPECIFY

<p>Select Model Number</p> <p>H 1 0 7 8 2 7 .</p>	<p>Select Laminate</p> <p>See page 299</p> <p>N N</p>
---	---

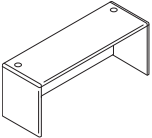
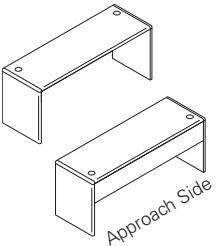

10700 SERIES™

Laminate Modular Components

	DESCRIPTION	INSIDE DIMENSIONS	MODEL	SHIP WEIGHT	CUBE	LIST PRICE
	Credenza Shell w/Full Modesty Panel					
	72"W x 24"D x 29½"H	69½"W x 22¾"D	H107817	156	6.0	\$941
	66"W x 24"D x 29½"H	63½"W x 22¾"D	H107816	145	5.5	\$877
	60"W x 24"D x 29½"H	57½"W x 22¾"D	H107815	133	5.0	\$828
	72"W x 20"D x 29½"H	69½"W x 18¾"D	H107837	140	5.3	\$919
	66"W x 20"D x 29½"H	63½"W x 18¾"D	H107836	132	4.8	\$856
	60"W x 20"D x 29½"H	57½"W x 18¾"D	H107835	127	3.8	\$814
	NOTES: One cord pass-through grommet in top center of modesty panel to reach wall electrical outlets. See pages 318-319 for optional stack-on storage.					
	Credenza Shell w/10"H Modesty Panel					
	72"W x 24"D x 29½"H	69½"W x 22¾"D	H107817X	127	6.0	\$941
	66"W x 24"D x 29½"H	63½"W x 22¾"D	H107816X	121	5.5	\$877
	60"W x 24"D x 29½"H	57½"W x 22¾"D	H107815X	115	5.0	\$828
	NOTES: Makes reaching wall electrical outlets quick and easy. Provides more than 18" of clearance. See pages 318-319 for optional stack-on storage.					
 <p>Not available in two-tone laminate</p>	Kneespace Clearance End Panel Kits (field installable)					
	1½"W x 11¼"D x 28⅝"H		H105098	13	0.9	\$210
	For use at either end of 10700, 10500 or Valido Series® 24"D Credenza Shells (with full or 10" modesty panel) or non-pedestal end of single pedestal credenzas or credenzas with lateral files.					
	1⅝"W x 17¼"D x 28⅝"H		H105099	11	0.8	\$220
	For use at either end of 10700, 10500 or Valido Series® 30"D Desk Shells or non-pedestal end of 30"D single pedestal desks.					
	Kits include: (1) support panel; European fastening hardware; flat connector bracket; joint connector bolts with sleeve nuts (for ganging credenza to adjacent worksurface); and adjustable leveling glides. Allows conversion of units currently in the field.					
	NOTES: Can be used to connect up to three 24"D credenzas or 30"D desks in line (requires 4 kits).					
	⚠ Not designed to be used freestanding. Not designed to be used with returns, 36"D desks or desk shells.					
	SPECIFYING EXAMPLE: H105098.N					

NOTES:

- Desk, credenza, and return shells, combined with a variety of under-the-worksurface storage solutions, maximize office layout flexibility. Products can be reconfigured quickly and easily when user preferences or space needs change.
- Worksurfaces and end panels feature contract-grade scratch, stain and spill resistant laminate over durable 1/8" solid core high-performance particleboard; resists warping.
- Contoured hardwood trim; stained to match laminate.
- User friendly waterfall-shaped edges and rounded corners.
- Formal, full height or 10" modesty panels.
- Cord management grommets, for routing and hiding wires and cables, are located in the tops of desk, credenza, and return shells. Grommets also serve as anchor points for stack-on storage and organizers.
- Shells utilize 10500 Series™ mobile pedestals or modular pedestals. See pages 259-261.
- See pages 310-311 for modular storage components.

HOW TO SPECIFY

Select Model Number H 1 0 7 8 1 7 .	Select Laminate See page 299 N N
---	---

10700 SERIES™

Laminate Modular Components

GSA SIN 33721



Icon Legend on page 19

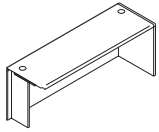

Model H107727R shown

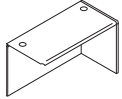

Model H107805R shown

DESCRIPTION	INSIDE DIMENSIONS	MODEL	SHIP WEIGHT	CUBE	LIST PRICE
Right Return Shell w/Full Modesty Panel					
72"W x 24"D x 29½"H, Right (w/support; 2 grommets)	67"W x 22¾"D	H107727R	145	5.6	\$941
60"W x 24"D x 29½"H, Right (w/support; 2 grommets)	55"W x 22¾"D	H107807R	129	4.7	\$828
48"W x 24"D x 29½"H, Right (2 grommets)	47"W x 22¾"D	H107805R	100	4.0	\$664
42"W x 24"D x 29½"H, Right (2 grommets)	41"W x 22¾"D	H107803R	95	3.5	\$633
36"W x 24"D x 29½"H, Right (2 grommets)	34¾"W x 22⅝"D	H107801R	83	3.4	\$633
30"W x 24"D x 29½"H (1 grommet)	28¾"W x 22¾"D	H107725R	69	2.4	\$614
Left Return Shell w/Full Modesty Panel					
72"W x 24"D x 29½"H, Left (w/support; 2 grommets)	67"W x 22¾"D	H107728L	145	5.6	\$941
60"W x 24"D x 29½"H, Left (w/support; 2 grommets)	55"W x 22¾"D	H107808L	129	4.7	\$828
48"W x 24"D x 29½"H, Left (2 grommets)	47"W x 22¾"D	H107806L	100	4.0	\$664
42"W x 24"D x 29½"H, Left (2 grommets)	41"W x 22¾"D	H107804L	95	3.5	\$633
36"W x 24"D x 29½"H, Left (2 grommets)	34¾"W x 22⅝"D	H107802L	83	3.4	\$633
30"W x 24"D x 29½"H (1 grommet)	28¾"W x 22¾"D	H107726L	69	2.4	\$614

NOTES: One cord pass-through grommet in top center of modesty panel to reach wall electrical outlets. Woodgrain direction on modesty/back panel runs vertical on 30"W-60"W sizes and horizontal on 72"W unit. Stack-on model H10734 is sized to be used on the 72"W return shell. Stack-on model H10732 will work on the 60"W return shell. Stack-on storage model H107313 fits on the 48"W return shell. Stack-on storage model H10734 will work on a 36"W return shell attached to the 36" corner unit; attaches to the return shell through the grommet hole and to the corner unit via double-sided tape. 36"W return shell can be used to achieve a 6' x 6' footprint when connected to either a 72"W x 36"D single pedestal desk, desk shell or peninsula, or when two are connected to a 36" corner unit model H107811.

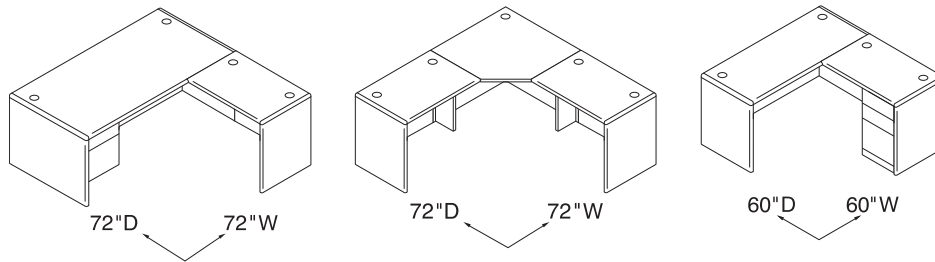

! All 10700 Series™ grommets on desk, credenza, credenza shell, return, return shell, bridge and corner unit worksurfaces changed from rectangle-shaped to round, effective November, 2011.

NOTES:

- Worksurfaces and end panels feature contract-grade scratch, stain and spill resistant laminate over durable 1½" solid core high-performance particleboard; resists warping.
- Contoured hardwood trim; stained to match laminate.
- User friendly waterfall-shaped edges and rounded corners.
- Formal, full height or 10" modesty panels.
- Cord management grommets, for routing and hiding wires and cables, are located in the tops of desk, credenza, and return shells. Grommets also serve as anchor points for stack-on storage and organizers.
- For work-in-process paper management tools, see page 325.
- For conference table options, see the Preside® table tops and bases in the Tables section in the 2021 Shared Spaces Pricer.
- Shells utilize 10500 Series™ mobile pedestals or modular pedestals. See pages 259-261.
- See pages 310-311 for modular storage components.

HOW TO SPECIFY

Select Model Number <input type="text" value="H107727R."/>	Select Laminate <input type="text" value="NN"/>
See page 299	



10700 SERIES™ Laminate Modular Components

	DESCRIPTION	INSIDE DIMENSIONS	MODEL	SHIP WEIGHT	CUBE	LIST PRICE
	Right Return Shell w/10" H Modesty Panel					
	72"W x 24"D x 29½"H, Right (w/support; 2 grommets)	67"W x 22¾"D	H107727RX	113	5.6	\$941
	60"W x 24"D x 29½"H, Right (w/support; 2 grommets)	55"W x 22¾"D	H107807RX	105	4.7	\$828
	48"W x 24"D x 29½"H, Right (2 grommets)	47"W x 22¾"D	H107805RX	81	4.0	\$664
	42"W x 24"D x 29½"H, Right (2 grommets)	41"W x 22¾"D	H107803RX	78	3.5	\$633
	36"W x 24"D x 29½"H, Right (2 grommets)	34¾"W x 22⅝"D	H107801RX	69	3.4	\$633
	Left Return Shell w/10" H Modesty Panel					
	72"W x 24"D x 29½"H, Left (w/support; 2 grommets)	67"W x 22¾"D	H107728LX	113	5.6	\$941
	60"W x 24"D x 29½"H, Left (w/support; 2 grommets)	55"W x 22¾"D	H107808LX	105	4.7	\$828
	48"W x 24"D x 29½"H, Left (2 grommets)	47"W x 22¾"D	H107806LX	81	4.0	\$664
	42"W x 24"D x 29½"H, Left (2 grommets)	41"W x 22¾"D	H107804LX	78	3.5	\$633
	36"W x 24"D x 29½"H, Left (2 grommets)	34¾"W x 22⅝"D	H107802LX	69	3.4	\$633

NOTES: Makes reaching wall electrical outlets quick and easy. Provides more than 18" of clearance.

	Non-Handed Return Shell w/10" H Modesty Panel					
	30"W x 20"D x 29½"H	28¾"W x 18¾"D	H107270X	47	2.4	\$588

NOTES: Makes reaching wall electrical outlets quick and easy; provides more than 18" of clearance. Ideal for smaller spaces. Connects to single pedestal desks and credenzas, peninsulas, or desk or credenza shells. Designed to fit over 10500 Series™ mobile pedestal models H105106 (box/file) or H105109 (shelf/box/file) and modular pedestal models H105012 (box/box/file) or H105014 (file/file).

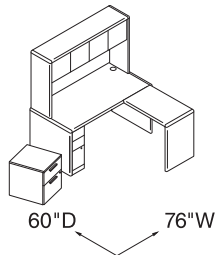

H107825X
H105093
H10732 (for desk shell)
H107270X
H105106

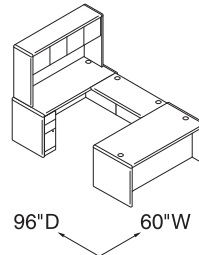

H107825
H107398
H107815X
H105093
H10732

! All 10700 Series™ grommets on desk, credenza, credenza shell, return, return shell, bridge and corner unit worksurfaces changed from rectangle-shaped to round, effective November, 2011.

NOTES:

- Worksurfaces and end panels feature contract-grade scratch, stain and spill resistant laminate over durable 1½" solid core high-performance particleboard; resists warping.
- Contoured hardwood trim; stained to match laminate.
- User friendly waterfall-shaped edges and rounded corners.
- Formal, full height or 10" modesty panels.
- 3" round cord management grommets, for routing and hiding wires and cables, are located in the tops of desk, credenza, and return shells. Grommets also serve as anchor points for stack-on storage and organizers.
- Grommet can be replaced with optional Power Hub or Power/USB Hub for easy plug-and-play. See page 328.
- For conference table options, see the Preside® table tops and bases in the Tables section in the 2021 Shared Spaces Pricer.
- Shells utilize 10500 Series™ mobile pedestals or modular pedestals. See pages 259-261.
- See pages 310-311 for modular storage components.

! Disperse fabrics not available on 72"W panels.

HOW TO SPECIFY

Select Model Number <input type="text" value="H107727RX"/>	Select Laminate See page 299 <input type="text" value="NN"/>
--	---

10700 SERIES™

Laminate Modular Components

GSA SIN 33721

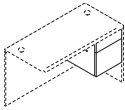
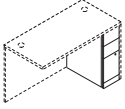
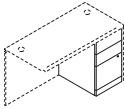
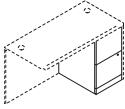
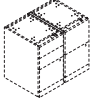

Icon Legend on page 19

	DESCRIPTION	MODEL	SHIP WEIGHT	CUBE	LIST PRICE
	<p>Box/File Pedestal (with core removable lock) 15$\frac{3}{8}$"W x 22$\frac{3}{4}$"D x 17$\frac{3}{4}$"H — for use under 24"D, 30"D and 36"D desk, credenza and return shells</p> <p>NOTES: Hangrails included. Lock can be positioned on either the right or left side. Attaches to underside of worksurface top. Not for use under 20"D shells.</p> <p>⚠ Not designed to be used freestanding. Unfinished top and back.</p>	H10501	57	5.5	\$523
	<p>Narrow Box/Box/File Pedestal (with core removable lock) — floor-standing 9$\frac{1}{2}$"W x 22$\frac{3}{4}$"D x 28"H — for use under 24"D, 30"D and 36"D desk, credenza and return shells</p> <p>NOTES: Compact design is ideal for use in U- and L-shaped layouts for smaller spaces such as 5' x 8' U-workstation or a 5' x 5' L-workstation. Middle box drawer and file drawer lock; top box drawer does not lock. File drawer includes integrated hangrails for side-to-side letter or legal filing. Field installable handle choices for this model are the Sweep, Crescent, and Arch only. Not for use with 20"D shells.</p> <p>⚠ Not designed to be used freestanding; unfinished top and back.</p>	H105093	61	5.6	\$676
	<p>Box/Box/File Pedestal (with core removable lock) — floor-standing 15$\frac{3}{8}$"W x 22$\frac{3}{4}$"D x 28"H — for use under 24"D, 30"D and 36"D desk, credenza and return shells</p> <p>NOTES: Top box drawer does not lock. Hangrails included. Not for use under 20"D shells.</p> <p>⚠ Not designed to be used freestanding. Unfinished top and back.</p>	H10502	90	8.4	\$686
	<p>File/File Pedestal (with core removable lock) — floor-standing 15$\frac{3}{8}$"W x 22$\frac{3}{4}$"D x 28"H — for use under 24"D, 30"D and 36"D desk, credenza and return shells</p> <p>NOTES: Hangrails included. Not for use under 20"D shells.</p> <p>⚠ Not designed to be used freestanding. Unfinished top and back.</p>	H10504	85	8.2	\$686
	<p>Access Strip (Filler) 1$\frac{1}{8}$"W x 20$\frac{1}{2}$"D x 28"H</p> <p>NOTES: For use with B/B/F, F/F, and or P/M/F pedestals are configured side-by-side. Not required when pedestals are used in conjunction with lateral file pedestal, multi file pedestal or cabinet pedestal. Not for use under 20"D shells.</p> <p>⚠ All 10700 Series™ grommets on desk, credenza, credenza shell, return, return shell, bridge and corner unit worksurfaces changed from rectangle-shaped to round, effective November, 2011.</p>	H10524	21	0.9	\$176

NOTES:

- Pedestals can be reconfigured quickly and easily when user preferences or space needs change.
- Pedestal models ship assembled unless designated ⚠.
- Locking units equipped with interchangeable core removable locks.
- See pages 306-309 for modular desk, credenza and return shells.

⚠ Keyed alike cores must be ordered separately — see page 746.

⚠ Pedestals are not designed to be used freestanding. Unfinished top and back.

⚠ Access strip (filler) required when full height pedestals are configured side-by-side to allow access for opening the drawers.

HOW TO SPECIFY

Select Model Number <input type="text" value="H10501"/>	Select Laminate <input type="text" value="N"/>
See page 299	

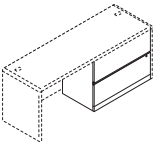
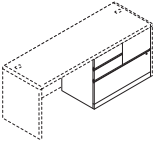
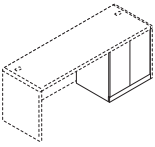
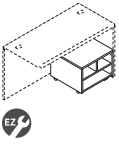

10700 SERIES™ Laminate Modular Components

	DESCRIPTION	MODEL	SHIP WEIGHT	CUBE	LIST PRICE
	<p>Lateral File Pedestal (with core removable lock) – floor-standing 36"W x 20"D x 28"H — for use under 24"D, 30"D and 36"D desk, credenza and return shells</p> <p>NOTES: Designed for use with credenza or return shells. Hangrails included. Mechanical interlock inhibits extension of more than one drawer at a time. Not for use under 20"D shells.</p> <p>⚠ Not designed to be used freestanding. Unfinished top and back.</p>	H10503	127	15.6	\$1042
	<p>Multi File Pedestal (with core removable lock) – floor-standing 36"W x 20"D x 28"H — for use under 24"D, 30"D and 36"D desk, credenza and return shells</p> <p>NOTES: Designed for use with credenza or return shells. Versatile four drawer unit features one lateral file drawer, one vertical file drawer, and two box drawers. Box drawers do not lock. Hangrails included. Mechanical interlock in lateral drawer inhibits extension of more than one drawer at a time. Not for use under 20"D shells.</p> <p>⚠ Not designed to be used freestanding. Unfinished top and back.</p>	H10505	155	15.6	\$1249
	<p>Cabinet Pedestal – floor-standing 26"W x 21¼"D x 28"H — for use under 24"D, 30"D and 36"D desk, credenza and return shells</p> <p>NOTES: One adjustable shelf at 2½" increments. For use with credenza or return shells. Doors are non-locking. Not for use under 20"D shells.</p> <p>⚠ Not designed to be used freestanding. Unfinished top and back.</p>	H10508	78	12.2	\$777
	<p>Mobile Printer/Fax Cart 20"W x 19⅞"D x 14⅞"H</p> <p>NOTES: Holds laser printers, inkjet printers or fax machines. Ideal for limited space. Low profile cart stores conveniently and easily under desks and workstations. Interior compartment shelving is Black. Four casters. Not for use under 20"D shells. Flat edge profile on top.</p> <p>SPECIFYING EXAMPLE: H105679.NN</p> <p>⚠ All 10700 Series™ grommets on desk, credenza, credenza shell, return, return shell, bridge and corner unit worksurfaces changed from rectangle-shaped to round, effective November, 2011.</p>	H105679	52	2.9	\$420

NOTES:

- Pedestals can be reconfigured quickly and easily when user preferences or space needs change.
- Locking units equipped with interchangeable core removable locks.
- See pages 306-309 for modular desk, credenza and return shells.
- ⚠ Keyed alike cores must be ordered separately — see HF23B on page 746.
- ⚠ Pedestals are not designed to be used freestanding. Unfinished top and back.
- ⚠ Access strip (filler) required when full height pedestals are configured side-by-side to allow access for opening the drawers.

HOW TO SPECIFY

Select Model Number H 1 0 5 0 3 . N	Select Laminate See page 299
---	--

10700 SERIES™

Laminate Wood Desks — Full Pedestals

GSA SIN 33721



Icon Legend on page 19

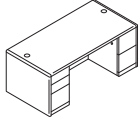

DESCRIPTION	RECESSED MODESTY PANEL	MODEL	SHIP WEIGHT	CUBE	LIST PRICE
Double Pedestal Desk w/Woodgrain Breakfront Modesty Panel — 3/2					
72"W x 36"D x 29½"H	10½"	H10799	371	52.9	\$2164
66"W x 30"D x 29½"H	4½"	H10774	313	40.9	\$2088
60"W x 30"D x 29½"H	4½"	H10773	305	37.3	\$1987
NOTES: All drawers lock. Two worksurface grommets to route/hide cords. See page 326 for optional center drawers.					

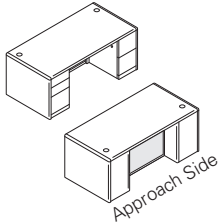

Double Pedestal Desk w/Frosted Breakfront Modesty Panel — 3/2					
72"W x 36"D x 29½"H	10½"	H10799G	366	51.8	\$2653
NOTES: All drawers lock. Two worksurface grommets to route/hide cords. See page 326 for optional center drawers.					

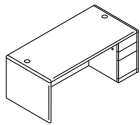

Single Pedestal Desk w/Woodgrain Breakfront Modesty Panel — Box/box/file					
72"W x 36"D x 29½"H, Right	10½"	H10787R	317	52.9	\$1868
66"W x 30"D x 29½"H, Right	4½"	H10701R	270	40.9	\$1717
72"W x 36"D x 29½"H, Left	10½"	H10788L	317	52.9	\$1868
66"W x 30"D x 29½"H, Left	4½"	H10702L	270	40.9	\$1717
NOTES: Drawers lock. Two worksurface grommets to route/hide cords. See page 326 for optional center drawers.					

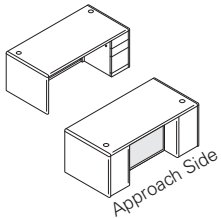

Single Pedestal Desk w/Frosted Breakfront Modesty Panel — Box/box/file					
72"W x 36"D x 29½"H, Right	10½"	H10787RG	313	51.8	\$2356
72"W x 36"D x 29½"H, Left	10½"	H10788LG	313	51.8	\$2356
NOTES: Drawers lock. Two worksurface grommets to route/hide cords. See page 326 for optional center drawers.					

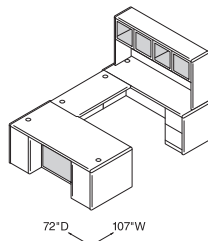

H10788L
H10770
H10707R
H10734G

! All 10700 Series™ grommets on desk, credenza, credenza shell, return, return shell, bridge and corner unit worksurfaces changed from rectangle-shaped to round, effective November, 2011.

NOTES:

- Worksurfaces and end panels feature contract-grade scratch, stain and spill resistant high-pressure laminate over durable 1/8" solid core high-performance particleboard.
- Contoured hardwood trim; stained to match laminate.
- User friendly waterfall-shaped edges.
- Full-to-floor pedestals maximize storage space.
- Breakfront modesty panel design on full height pedestal desks. See approach side illustration above.
- Grommet can be replaced with optional Power Hub or Power/USB Hub for easy plug-and-play. See page 328.
- All drawers are 5-sided construction, which allows easy drawer alignment or replacement of drawer fronts.
- File drawer design includes integrated hangrails for side-to-side letter or legal filing; and front-to-back for letter filing.
- Adjustable hex leveling glides allow floor-standing furniture to be easily leveled without lifting the unit; glides have 3/4" adjustable range.
- Desk, credenza, and return models ship assembled; ready to set in place.
- See pages 316-328 for shared components.

HOW TO SPECIFY

Select Model Number	Select Laminate
H 1 0 7 9 9 .	See page 299
N N	



10700 SERIES™

Laminate Wood Desks — Full Pedestals

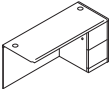
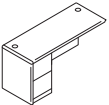
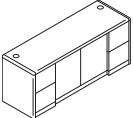
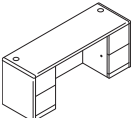
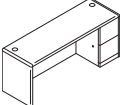
	DESCRIPTION	RECESSED MODESTY PANEL	MODEL	SHIP WEIGHT	CUBE	LIST PRICE
	Return — Right file/file (2 grommets)					
	60"W x 24"D x 29½"H		H10709R	176	29.7	\$1327
	48"W x 24"D x 29½"H		H10711R	158	24.9	\$1149
	42"W x 24"D x 29½"H		H107191R	150	22.1	\$1136
	NOTES: Drawers lock. Two worksurface grommets to route/hide cords and one cord pass-through grommet in top center of modesty panel. See pages 318-319 for optional stack-on storage.					
	⚠ Not designed to be used freestanding.					
	Return — Left file/file (2 grommets)					
	60"W x 24"D x 29½"H		H10710L	176	29.7	\$1327
	48"W x 24"D x 29½"H		H10712L	158	24.9	\$1149
	42"W x 24"D x 29½"H		H107192L	150	22.1	\$1136
	NOTES: Drawers lock. Two worksurface grommets to route/hide cords and one cord pass-through grommet in top center of modesty panel. See pages 318-319 for optional stack-on storage.					
	⚠ Not designed to be used freestanding.					
	Credenza with Doors					
	72"W x 24"D x 29½"H	3½"	H10742	314	36.0	\$2164
	NOTES: All drawers lock. Doors are non-locking. Two worksurface grommets to route/hide cords and one pass-through grommet in top center of modesty panel. Includes a fixed shelf located at the bottom of the center storage area. No intermittent shelf. See pages 318-319 for optional stack-on storage.					
	Credenza with Kneespace — 2/0/2					
	72"W x 24"D x 29½"H	3½"	H10741	280	36.0	\$1868
	66"W x 24"D x 29½"H	3½"	H10768	270	33.4	\$1757
	60"W x 24"D x 29½"H	3½"	H10767	241	28.8	\$1708
	NOTES: All drawers lock. Two worksurface grommets to route/hide cords and one pass-through grommet in top center of modesty panel. See pages 318-319 for optional stack-on storage.					
	⚠ Not designed to be used with 22¾"D modular or mobile pedestals. Modesty/back panel is inset 3½".					
	Single Pedestal Credenza, File/File					
	72"W x 24"D x 29½"H, Right	3½"	H10707R	235	36.3	\$1529
	66"W x 24"D x 29½"H, Right	3½"	H10705R	225	33.4	\$1502
	72"W x 24"D x 29½"H, Left	3½"	H10708L	235	36.3	\$1529
	66"W x 24"D x 29½"H, Left	3½"	H10706L	225	33.4	\$1502
	NOTES: Drawers lock. Two worksurface grommets to route/hide cords and one cord pass-through grommet in top center of modesty panel. See pages 318-319 for optional stack-on storage.					
	⚠ Not designed to be used with 22¾"D modular or mobile pedestals. Modesty/back panel is inset 3½".					
	⚠ All 10700 Series™ grommets on desk, credenza, credenza shell, return, return shell, bridge and corner unit worksurfaces changed from rectangle-shaped to round, effective November, 2011.					

NOTES:

- Worksurfaces and end panels feature contract-grade scratch, stain and spill resistant high-pressure laminate over durable 1/8" solid core high-performance particleboard.
- Contoured hardwood trim; stained to match laminate.
- User friendly waterfall-shaped edges.
- Full-to-floor pedestals maximize storage space.
- Breakfront modesty panel design on full height pedestal desks. See approach side illustration on page 312.
- Cord management grommets serve as anchor points for stack-on storage and organizers.
- All drawers are 5-sided construction, which allows easy drawer alignment or replacement of drawer fronts.
- File drawer design includes integrated hangrails for side-to-side letter or legal filing; and front-to-back for letter filing.
- Adjustable hex leveling glides allow floor-standing furniture to be easily leveled without lifting the unit; glides have 3/4" adjustable range.
- Desk, credenza, and return models ship assembled; ready to set in place.
- For work-in-process paper management tools, see page 325.
- See pages 316-328 for shared components.

HOW TO SPECIFY

Select Model Number	Select Laminate
	See page 299
H 1 0 7 0 9 R .	N N

10700 SERIES™

Laminate Wood Desks — 3/4 Pedestals

GSA SIN 33721

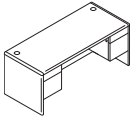
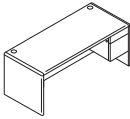
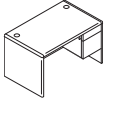
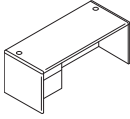
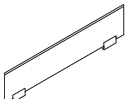

Icon Legend on page 19

	DESCRIPTION	FULL WIDTH OVERHANG	MODEL	SHIP WEIGHT	CUBE	LIST PRICE
	Double Pedestal Desk, 2-2					
	72"W x 36"D x 29½"H	10½"	H10791	340	52.9	\$1690
	66"W x 30"D x 29½"H	4½"	H10775	290	40.9	\$1614
	60"W x 30"D x 29½"H	4½"	H10771	266	37.4	\$1422
	NOTES: All drawers lock. Two worksurface grommets to route/hide cords. See page 326 for optional center drawers.					
	Single Pedestal Desk, Right box/file					
	72"W x 36"D x 29½"H	10½"	H10785R	279	52.9	\$1400
	66"W x 30"D x 29½"H	4½"	H10783R	239	41.0	\$1277
	NOTES: Drawers lock. Two worksurface grommets to route/hide cords. See page 326 for optional center drawers.					
	Small Office Desk, 3/4 Pedestal, Right box/file					
	48"W x 30"D x 29½"H		H107885R	191	30.2	\$1172
	NOTES: Footprint is ideal for limited space. Drawers lock. Two cord management grommets in the top. 3/4 height modesty panel facilitates reaching wall electrical outlets. Optional stack-on storage model H107313 maximizes storage space. See page 326 for optional center drawers.					
	Single Pedestal Desk, Left box/file					
	72"W x 36"D x 29½"H	10½"	H10786L	279	52.9	\$1400
	66"W x 30"D x 29½"H	4½"	H10784L	239	41.0	\$1277
	NOTES: Drawers lock. Two worksurface grommets to route/hide cords. See page 326 for optional center drawers.					
<p>! All 10700 Series™ grommets on desk, credenza, credenza shell, return, return shell, bridge and corner unit worksurfaces changed from rectangle-shaped to round, effective November, 2011.</p>						
	Above Privacy Screen					
	60"W x 13"H		HLSL1260	24	2.9	\$462
	54"W x 13"H		HLSL1254	22	2.9	\$430
	48"W x 13"H		HLSL1248	20	2.3	\$402
	42"W x 13"H		HLSL1242	18	2.3	\$352
	36"W x 13"H		HLSL1236	15	1.8	\$314
	30"W x 13"H		HLSL1230	13	1.5	\$285
	NOTES: Ships complete with attachment bracket. Bracket is Platinum only, no need to specify. Attaches to top of rectangle worksurfaces; requires a minimum overhang of 1½".					
	! Available in Frosted Glass ONLY HLSL1230.G.					
	! Above only Privacy Screen clamps onto worksurface and cannot be installed where support storage will be attached.					

NOTES:

- Worksurfaces and end panels feature contract-grade scratch, stain and spill resistant high-pressure laminate over durable 1½" solid core high-performance particleboard.
- Contoured hardwood trim; stained to match laminate.
- User friendly waterfall-shaped edges and rounded corners.
- 3/4 pedestal design increases budget flexibility.
- Formal, full height modesty panels.
- Drawers operate on full extension, ball-bearing suspensions to ensure smooth, quiet, long-lasting operation.
- All drawers are 5-sided construction, which allows easy drawer alignment or replacement of drawer fronts.
- File drawer design includes integrated hangrails for side-to-side letter or legal filing; and front-to-back for letter filing.
- Grommet can be replaced with optional Power Hub or Power/USB Hub for easy plug-and-play. See page 328.
- Adjustable hex leveling glides allow floor-standing furniture to be easily leveled without lifting the unit; glides have ¾" adjustable range.
- Desk, credenza, and return models ship assembled; ready to set in place.
- Center drawers conveniently store writing instruments, paper and other miscellaneous items. Includes pencil tray. See page 326.
- See pages 316-328 for shared components.

HOW TO SPECIFY

Select Model Number	Select Laminate
	See page 299
H 1 0 7 9 1 .	N N



10700 SERIES™

Laminate Wood Desks — 3/4 Pedestals

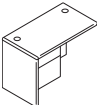
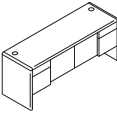
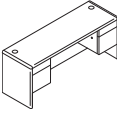
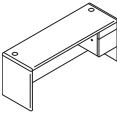
	DESCRIPTION	FULL WIDTH OVERHANG	MODEL	SHIP WEIGHT	CUBE	LIST PRICE
 <p>Model H10717R shown</p>	Return — Right box/file (2 grommets)					
	60"W x 24"D x 29½"H		H10717R	173	29.7	\$1067
	48"W x 24"D x 29½"H		H10715R	147	25.3	\$942
	42"W x 24"D x 29½"H		H107193R	136	22.1	\$917
	NOTES: Drawers lock. Two worksurface grommets and one cord pass-through grommet in top center of modesty panel. See pages 318-319 for optional stack-on storage.					
	⚠ Not designed to be used freestanding.					
 <p>Model H10716L shown</p>	Return — Left box/file (2 grommets)					
	60"W x 24"D x 29½"H		H10718L	173	29.7	\$1067
	48"W x 24"D x 29½"H		H10716L	147	25.3	\$942
	42"W x 24"D x 29½"H		H107194L	136	22.1	\$917
	NOTES: Drawers lock. Two worksurface grommets and one cord pass-through grommet in top center of modesty panel to reach wall electrical outlets. See pages 318-319 for optional stack-on storage.					
	⚠ Not designed to be used freestanding.					
	Credenza with Doors	3½"	H10744	278	36.0	\$1704
	72"W x 24"D x 29½"H					
	NOTES: All drawers lock. Hinged doors are non-locking. Two worksurface grommets and one cord pass-through grommet in top center of modesty panel to reach wall electrical outlets. Includes a fixed shelf located at the bottom of the center storage area. No intermittent shelf. See pages 318-319 for optional stack-on storage.					
	Credenza with Kneespace	3½"	H10743	243	36.3	\$1520
	72"W x 24"D x 29½"H					
	66"W x 24"D x 29½"H	3½"	H10766	234	33.4	\$1420
	60"W x 24"D x 29½"H	3½"	H10765	229	28.8	\$1356
	NOTES: Drawers lock. Two worksurface grommets and one cord pass-through grommet in top center of modesty panel to reach wall electrical outlets. See pages 318-319 for optional stack-on storage.					
	⚠ Not designed to be used with 22¾"D modular or mobile pedestals. Modesty/back panel is inset 3½".					
	Single Pedestal Credenza, Box/File	3½"	H10745R	212	36.0	\$1228
	72"W x 24"D x 29½"H, Right					
	66"W x 24"D x 29½"H, Right	3½"	H10763R	203	33.4	\$1208
	72"W x 24"D x 29½"H, Left	3½"	H10746L	212	36.0	\$1228
	66"W x 24"D x 29½"H, Left	3½"	H10764L	203	33.4	\$1208
	NOTES: Drawers lock. Two worksurface grommets and one cord pass-through grommet in top center of modesty panel to reach wall electrical outlets. See pages 318-319 for optional stack-on storage.					
	⚠ Not designed to be used with 22¾"D modular or mobile pedestals. Modesty/back panel is inset 3½".					
	⚠ All 10700 Series™ grommets on desk, credenza, credenza shell, return, return shell, bridge and corner unit worksurfaces changed from rectangle-shaped to round, effective November, 2011.					

NOTES:

- Worksurfaces and end panels feature contract-grade scratch, stain and spill resistant high-pressure laminate over durable 1½" solid core high-performance particleboard.
- Contoured hardwood trim; stained to match laminate.
- User friendly waterfall-shaped edges and rounded corners.
- 3/4 pedestal design increases budget flexibility.
- Formal, full height modesty panels.
- Cord management grommets also serve as anchor points for stack-on storage and organizers.
- All drawers are 5-sided construction, which allows easy drawer alignment or replacement of drawer fronts.
- File drawer design includes integrated hangrails for side-to-side letter or legal filing; and front-to-back for letter filing.
- Adjustable hex leveling glides allow floor-standing furniture to be easily leveled without lifting the unit; glides have ¾" adjustable range.
- Desk, credenza, and return models ship assembled; ready to set in place.
- For work-in-process paper management tools, see page 325.
- See pages 316-328 for shared components.

HOW TO SPECIFY

Select Model Number	Select Laminate
	See page 299
H 1 0 7 4 5 R .	N N

10700 SERIES™

Shared Components and Accessories

GSA SIN 33721

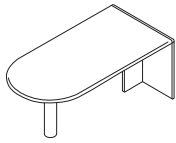

Icon Legend on page 19

**DESCRIPTION****Peninsula w/End Panel and Steel Support Column**

72"W x 36"D x 29½"H
66"W x 30"D x 29½"H

MODEL**SHIP WEIGHT****CUBE****LIST PRICE****H10721**

150

15.1

\$1382**H10722**

125

11.8

\$1208

NOTES: Use for "U" or "L" configuration. Cord routing notch in brace panel. Round support column is black. Peninsula models H10721 and H10722 ship complete with end panel and black 3" diameter support column. For a silver support column option, please see model HPC191X on page 251 (ordered separately).

⚠ Not designed to be used freestanding.

**Field Installable Laminate Modesty Panel**

50¼"W x ¾"Thick x 18"H

H10528

25

1.3

\$188

NOTES: Center drawer model H1522 can be used in conjunction with modesty panel. Cord pass-through notch in top corner of modesty panel. See page 326 for optional center drawers.

⚠ Not designed to attach to peninsulas manufactured prior to 12/1/2001.

SPECIFYING EXAMPLE: H10528.N**Field Installable Modesty Panel, Frosted with Silver Frame**

50¼"W x ¾"Thick x 18"H — for use on 72"W peninsulas

HPC180G

33 Ⓢ

1.5

\$694

⚠ Center drawers not designed to be used with the frosted/silver modesty panel.

NOTES:

- Shared components on this page can be used with modular, full pedestal, and 3/4 pedestal models shown on pages 306-315.
- Multi file is a versatile four drawer unit featuring two box drawers, one file drawer, and one lateral file drawer with mechanical interlock.
- Cord management grommets, for routing and hiding wires and cables, are located in the tops of desks, credenzas, and returns. Grommets also serve as anchor points for stack-on storage and organizers.
- Cord pass-through grommet located in the back/modesty panel of returns, bridges and credenzas, facilitates reaching wall electrical outlets.
- All drawers are 5-sided construction, which allows easy drawer alignment or replacement of drawer fronts.
- Locking units equipped with interchangeable core removable locks.
- Stack-on storage attaches with two removable mounting brackets.
- Adjustable hex leveling glides allow floor-standing furniture to be easily leveled without lifting the unit; glides have ¾" adjustable range.
- See pages 316-328 for shared components.

⚠ Keyed alike cores must be ordered separately — see page 746.

HOW TO SPECIFY

Select Model Number H 1 0 7 2 1 .	Select Laminate See page 299 N N
---	---

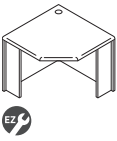

10700 SERIES™ Shared Components and Accessories

DESCRIPTION	MODEL	SHIP WEIGHT	CUBE	LIST PRICE
 <p>Corner Unit 24" x 36" x 36" x 24" x 29½"H – (1 grommet in top) Works with 24"D x 29½"H returns or bridges.</p> <p>NOTES: The corner unit has rounded, solid wood trim on the front and back. Return and bridge connections are inset inside the wood profiles, per the drawing shown. Support legs feature cutouts for routing cords. Can be used freestanding.</p>	H107811	136	4.2	\$1245

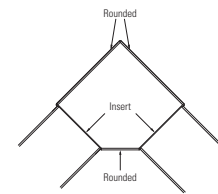
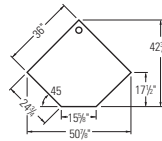

DESCRIPTION	FULL WIDTH OVERHANG	MODEL	SHIP WEIGHT	CUBE	LIST PRICE
 <p>Bridge (Single Ped. Desk, Desk Shell or Peninsula to Corner Unit or Single Ped. Credenza or Credenza Shell) 47"W x 24"D x 29½"H, (Clear inside depth = 22¾"D) 42"W x 24"D x 29½"H, (Clear inside depth = 22¾"D) 36"W x 24"D x 29½"H, (Clear inside depth = 22¾"D) (for use with Corner Units) 47"W x 20"D x 29½"H, (Clear inside depth = 18¾"D) 42"W x 20"D x 29½"H, (Clear inside depth = 18¾"D)</p> <p>NOTES: Two cord grommets in top; one cord pass-through grommet in top center of modesty panel. Grommets can be replaced with optional Power Hub or Power/USB Hub for easy plug-and-play (see page 328). Kneespace of desk limited to 24¾"W if bridge is used with 66"W single pedestal desk.</p>		H10770 H10760 H10751 H107399 H107398	81 69 64 68 56	2.5 2.6 2.5 2.8 2.6	\$426 \$410 \$407 \$410 \$396

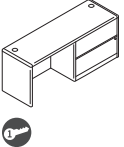
 <p>Credenza with 36" Lateral (with core removable lock) – 2 cord grommets in top 72"W x 24"D x 29½"H, Right 3½" 72"W x 24"D x 29½"H, Left 3½"</p> <p>NOTES: One cord pass-through grommet in top center of modesty panel. Mechanical interlock inhibits the extension of more than one drawer at a time. Optional stack-on models H10734, H10734K, and H10734G maximize storage space.</p> <p>⚠ Not designed to be used with 22¾"D modular or mobile pedestals. Modesty/back panel is inset 3½".</p>	H10747R H10748L	247 247	36.0 36.0	\$1691 \$1691
--	--------------------	------------	--------------	------------------

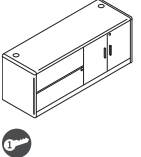
 <p>Credenza with Lateral File, Left and Storage Cabinet, Right 72"W x 24"D x 29½"H</p> <p>NOTES: Lateral file is equipped with mechanical interlock to inhibit the extension of more than one drawer at a time. Storage cabinet has one adjustable interior shelf which adjusts in 1¼" increments over a range of 5". Drawers and doors lock separately; the two locks are keyed alike. Can be used with optional stack-on storage. See page 318 for Stack-on Storage models H10734/H10734K/H10734G.</p>	3½"	H107492	307	35.6	\$2096
---	-----	---------	-----	------	--------

NOTES:

- Cord management grommets, for routing and hiding wires and cables, are located in the tops of desks, credenzas, and returns. Grommets also serve as anchor points for stack-on storage and organizers.
- Cord pass-through grommet located in the back/modesty panel of returns, bridges and credenzas, facilitates reaching wall electrical outlets.
- All drawers are 5-sided construction, which allows easy drawer alignment or replacement of drawer fronts.
- Locking units equipped with interchangeable core removable locks.
- Stack-on storage attaches with two removable mounting brackets.
- Adjustable hex leveling glides allow floor-standing furniture to be easily leveled without lifting the unit; glides have ¾" adjustable range.
- See pages 316-328 for shared components.

HOW TO SPECIFY

<p>Select Model Number</p> <p>H 1 0 7 7 0</p>	<p>Select Laminate</p> <p>See page 299</p> <p>N N</p>
---	---

10700 SERIES™

Shared Components and Accessories

GSA SIN 33721

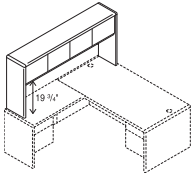

Icon Legend on page 19

**DESCRIPTION****Stack-on Storage for "L" Workstation**

74⁵/₈"W x 14⁵/₈"D x 37¹/₈"H
(Use Task Light model HH870960, see page 327)

Stack-on Storage for "L" Workstation, Locking

74⁵/₈"W x 14⁵/₈"D x 37¹/₈"H
(Use Task Light model HH870960, see page 327)

NOTES: Spans the total depth dimension of configurations comprised of: 48"W return or return shell attached to a 30"D single pedestal desk, desk shell or peninsula (78"D); 42"W return or return shell attached to a 36"D single pedestal desk, desk shell or peninsula (78"D) or 42"W return or return shell attached to a 36" corner unit (78"D). Attaches to desk, peninsula, or corner unit via double-sided tape, and to return through grommet hole. Inside storage consists of two compartments each 34³/₄"W x 12¹/₈"D x 12"H. Use back enclosure model H107358 and tackboard model H90035. For vertical paper manager, see page 325.

MODEL**SHIP WEIGHT****CUBE****LIST PRICE****H107318**

198

15.8

\$1382**H107318K**

198

15.8

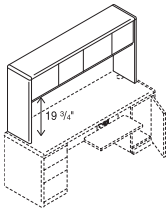
\$1466**Stack-on Storage**

68⁵/₈"W x 14⁵/₈"D x 37¹/₈"H, 4 doors (For 72"W Credenza)

62⁵/₈"W x 14⁵/₈"D x 37¹/₈"H, 4 doors (For 66"W Credenza)

56⁵/₈"W x 14⁵/₈"D x 37¹/₈"H, 4 doors (For 60"W Credenza or Return)

44⁵/₈"W x 14⁵/₈"D x 37¹/₈"H, 3 doors (For 48"W Return or 48"W Small Office Desk)

Stack-on Storage, Locking

68⁵/₈"W x 14⁵/₈"D x 37¹/₈"H, 4 doors (For 72"W Credenza)

62⁵/₈"W x 14⁵/₈"D x 37¹/₈"H, 4 doors (For 66"W Credenza)

56⁵/₈"W x 14⁵/₈"D x 37¹/₈"H, 4 doors (For 60"W Credenza or Return)

44⁵/₈"W x 14⁵/₈"D x 37¹/₈"H, 3 doors (For 48"W Return or 48"W Small Office Desk)

NOTES: Inside storage for H10734, H10733 and H10732 contains two compartments each sized: 32¹/₂"W, 28³/₄"W, 25³/₄"W respectively x 12¹/₈"D x 12"H. H107313 has 3 doors. Inside storage for H107313 contains two compartments: right side 12¹/₈"W, left side 26³/₄"W respectively x 12¹/₈"D x 12"H. Stack-ons attach through grommet holes on the worksurfaces of desks, credenzas and returns. Model 10734 can be used for "L" configuration comprised of 30"D desk, desk shell or peninsula and 42"W return or return shell; or a 36"D desk, desk shell, peninsula or corner unit and 36"W return shell. Model H107313K has one lock which secures two of the three doors. For task light and vertical paper manager, see pages 325 and 327.

H10734

175

16.0

\$1259**H10733**

168

14.4

\$1244**H10732**

161

13.0

\$1208**H107313**

147

10.3

\$1110**H10734K**

175

16.0

\$1343**H10733K**

168

14.4

\$1328**H10732K**

161

13.0

\$1292**H107313K**

147

10.3

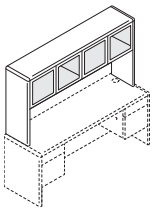
\$1173**Stack-on Storage w/Frosted Doors w/Silver Frame**

68⁵/₈"W x 14⁵/₈"D x 37¹/₈"H

H10734G

185

16.2

\$1892

NOTES: Rich woodgrain laminate and contemporary frosted doors with silver frames add a sleek mixed materials option to 10700 Series™. Accepts back enclosure model H10738, tackboard for use with back enclosure model H90034, task light HH870960 and vertical paper manager HVLPM1. Frosted door models are non-locking.

NOTES:

- Shared components on this page can be used with modular, full pedestal, and 3/4 pedestal models shown on pages 306-315.
- Stack-on storage models are equipped with self closing, adjustable hinged doors, and valance to hide task light.
- When spanning the total depth of an L-workstation, stack-on storage attaches to the desk, peninsula or corner unit via double-sided tape, and to the return through the grommet hole.
- Stack-on storage end panels are
- Stack-on storage and organizers attach with two removable mounting brackets, except for "L" workstation unit.
- Stacked paper management segments and organizes stack-on storage compartments and bookcase shelves. Unit can be used in stack-on storage models H107318 and H10734. See HLVPM2 on page 325.
- Vertical paper manager keeps papers, files, and books neatly organized and within easy reach from a seated position. Fits under stack-on storage models. See page 325.
- See pages 316-328 for shared components.

Upcharges may apply to premium tackboard fabric grades.

Removable lock core kit for locking stack-on storage is model HF27B. See page 746.

HOW TO SPECIFY

Select Model Number

H 1 0 7 3 4 .

Select Laminate

See page 299

N N



10700 SERIES™

Shared Components and Accessories

	DESCRIPTION	MODEL	COM	SHIP WEIGHT	CUBE	LIST PRICE		
 18 5/8" H	Back Enclosure for Stack-on Storage 72 1/4" W - for 74 5/8" W model #H107318/H107318K 66 1/4" W - for 68 5/8" W model #H10734/H10734K 60 1/4" W - for 62 5/8" W model #H10733/H10733K 54 1/4" W - for 56 5/8" W model #H10732/H10732K 42 1/4" W - for 44 5/8" W model #H107313/H107313K	H107358 H10738 H10737 H10736 H107353		34 31 29 27 22	1.3 1.3 1.3 1.3 0.9	\$273 \$251 \$233 \$223 \$223		
	NOTES: Non-tackable. Specify laminate. Features full width 1 1/8" slot at bottom to facilitate routing cords and reaching wall electrical outlets. H10738 can also be used with H10634 and H94234 stack-ons.							
	 18" H	Tackboards for use with Stack-on Back Enclosures (Back Enclosures must be ordered separately.) 71 1/2" W - for 74 5/8" W model #H107318/H107318K Hutch with #H107358 Enclosure 65 1/4" W - for 68 5/8" W model #H10734/H10734K Hutch with #H10738 Enclosure 59 1/4" W - for 62 5/8" W model #H10733/H10733K Hutch with #H10737 Enclosure 53 1/4" W - for 56 5/8" W model #H10732/H10732K Hutch with #H10736 Enclosure 41 1/2" W - for 44 5/8" W model #H107313/H107313K Hutch with #H107353 Enclosure	H90035 H90034 H90033 H90032 H90031	2.0 2.0 2.0 2.0 2.0	13 11 10 9 7	2.8 2.0 1.8 1.8 1.7	\$326 \$310 \$295 \$259 \$248	
		NOTES: Tackboards are sized 3/4" narrower than respective stack-on storage back enclosure, allowing 3/8" each side to route task light cords. Specify fabric selection from pages 25-26. Board is attached using latch & hook tape provided. H90034 can also be used with H10738 on H10634 and H94234 stack-ons.						
		ⓘ Disperse (DISP) fabric not available on sizes wider than 60".						
SPECIFYING EXAMPLE: H90035.APN15								

NOTES:

- Shared components on this page can be used with modular, full pedestal, and 3/4 pedestal models shown on pages 306-315.
- Stacked paper management segments and organizes stack-on storage compartments and bookcase shelves. Unit can be used in stack-on storage models H107318 and H10734. See HLVPM2 on page 325.
- Vertical paper manager keeps papers, files, and books neatly organized and within easy reach from a seated position. Fits under stack-on storage models. See page 325.
- See pages 316-328 for shared components.

ⓘ Upcharges may apply to premium tackboard fabric grades.

HOW TO SPECIFY

Select Model Number H 1 0 7 3 5 8	Select Laminate See page 299 N
---	---





10700 SERIES™

Shared Components and Accessories

GSA SIN 33721

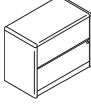
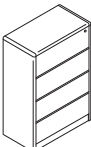
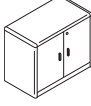
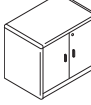
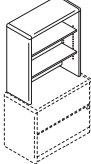

Icon Legend on page 19

	DESCRIPTION	MODEL	SHIP WEIGHT	CUBE	LIST PRICE
	Box/Box/File Mobile Pedestal (with core removable lock) 15 ³ / ₄ "W x 22 ³ / ₄ "D x 28 ⁵ / ₈ "H — use freestanding or under 24"D, 30"D and 36"D modular shells NOTES: Top box drawer does not lock. File drawer includes hangrails.	H105102	121	8.5	\$854
	File/File Mobile Pedestal (with core removable lock) 15 ³ / ₄ "W x 22 ³ / ₄ "D x 28 ⁵ / ₈ "H — use freestanding or under 24"D, 30"D and 36"D modular shells NOTES: File drawers include hangrails.	H105104	121	8.4	\$854
	Box/File Mobile Pedestal (with core removable lock) 15 ³ / ₄ "W x 18 ¹ / ₈ "D x 21 ¹ / ₈ "H — use freestanding or under 20"D, 24"D, 30"D and 36"D modular shells	H105106	65	5.8	\$714
 <i>Mobile pedestals have smooth, flat edges.</i>	Shelf/Box/File Mobile Pedestal (with core removable lock) 15 ³ / ₄ "W x 18 ¹ / ₈ "D x 28 ⁵ / ₈ "H — use freestanding or under 20"D, 24"D, 30"D and 36"D modular shells NOTES: Interior dimensions of the open storage area of the Shelf/Box/File model are 14 ¹ / ₈ "W x 16 ³ / ₄ "D x 6 ⁵ / ₈ "H.	H105109	73	7.3	\$786
	Lateral File (with core removable lock) 36"W x 24"D x 29 ¹ / ₂ "H — two drawer — matches depth of credenzas and returns 36"W x 20"D x 29 ¹ / ₂ "H — two drawer 36"W x 20"D x 45 ¹ / ₂ "H — three drawer 36"W x 20"D x 59 ¹ / ₈ "H — four drawer NOTES: Includes hangrails, mechanical interlock and, in H10762 and H107690, a counterweight. Interlock inhibits the extension of more than one drawer from opening at a time. 24"D size aligns evenly with 24"D credenzas, credenza shells, returns, return shells, and wardrobe/storage cabinets to provide linear layout continuity.	H107690	191	18.6	\$1254
		H10762	168	15.6	\$1208
		H107698	240	23.2	\$1859
		H107699	296	31.0	\$2564
	Storage Cabinet with Doors (with core removable lock) 36"W x 20"D x 29 ¹ / ₂ "H NOTES: One adjustable interior shelf.	H107291	144	15.0	\$978
	Storage Cabinet with Doors (with core removable lock) 36"W x 24"D x 29 ¹ / ₂ "H — matches depth of credenzas and returns NOTES: One adjustable interior shelf. 24"D size aligns evenly with 24"D credenzas, credenza shells, returns, return shells, and wardrobe/storage cabinets to provide linear layout continuity.	H107290	162	18.6	\$1075
	Bookcase Hutch 32 ⁵ / ₈ "W x 14 ⁵ / ₈ "D x 37 ¹ / ₈ "H NOTES: For use with Lateral Files (H10762, H107690) and Storage Cabinets (H107291, H107290). Cord pass-through gap behind shelves and a 1 ¹ / ₈ " full-width cord management slot at the bottom of the back panel to facilitate routing cords and reaching wall electrical outlets. When placed on a 29 ¹ / ₂ "H base unit, the total 66 ⁵ / ₈ "H matches the height of credenzas with stack-on storage and the height of the wardrobe/storage cabinet. Two shelves are adjustable in 1/4" increments.	H107292	93	5.1	\$726

NOTES:

- Shared components on this page can be used with modular, full pedestal, and 3/4 pedestal models shown on pages 306-315.
- Broad family of storage components takes organization way beyond the confines of a desk drawer.
- Mobile pedestal tops have smooth, flat edges. Units are standard with counterweight and four 2" diameter, non-locking casters.
- Locking units equipped with interchangeable core removable locks.
- Mobile pedestals, lateral files, storage cabinets, and bookcases ship assembled.
- See pages 316-328 for shared components.

! Keyed alike cores must be ordered separately — see model HF23B on page 746 — makes re-keying quick and easy.

HOW TO SPECIFY

Select Model Number	Select Laminate
See page 299	See page 299
H 1 0 5 1 0 2 .	N N



10700 SERIES™

Shared Components and Accessories

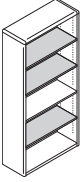
	DESCRIPTION	MODEL	SHIP WEIGHT	CUBE	LIST PRICE
	Bookcase w/Fixed Shelves				
	36"W x 13 ¹ / ₈ "D x 71"H, 5-Shelf	H10755	187	25.3	\$1076
	36"W x 13 ¹ / ₈ "D x 57 ¹ / ₈ "H, 4-Shelf	H10754	156	20.3	\$911
	36"W x 13 ¹ / ₈ "D x 43 ³ / ₈ "H, 3-Shelf	H10753	122	15.6	\$809
	36"W x 13 ¹ / ₈ "D x 29 ⁵ / ₈ "H, 2-Shelf	H10752	90	10.9	\$670
	NOTES: 36"W models with finished back. No assembly required. Ready to set in place.				
	Bookcase w/Adjustable Shelves				
	32 ³ / ₈ "W x 13 ¹ / ₈ "D x 71"H, 5-Shelf	H107569	170	25.1	\$1064
	NOTES: 32 ³ / ₈ "W design with five shelves; two fixed, three adjustable. Shelves adjust in 2 ¹ / ₂ " increments. Finished back.				

Shaded shelves are adjustable.

NOTES:

- Shared components on this page can be used with modular, full pedestal, and 3/4 pedestal models shown on pages 306-315.
- Broad family of storage components takes organization way beyond the confines of a desk drawer.
- Conventional bookcase designs ship fully assembled to ease and speed installation.
- See pages 316-328 for shared components.

HOW TO SPECIFY

Select Model Number H 1 0 7 5 2 .	Select Laminate See page 299 N N
---	---

10700 SERIES™

Shared Components and Accessories

GSA SIN 33721



Icon Legend on page 19



Doors open 110 degrees from closed position.

DESCRIPTION**MODEL****SHIP WEIGHT****CUBE****LIST PRICE****Storage Cabinet (with core removable lock)**36"W x 24"D x 66⁵/₈"H**H107299**

341

41.0

\$2367

NOTES: Large storage area includes five, full-width (side-to-side) shelves; three are adjustable in 2¹/₂" increments. Unit height is designed to match credenza or return plus stack-on height (66⁵/₈").

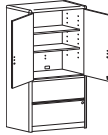

Doors open 110 degrees from closed position.

Storage Cabinet/Lateral File (with core removable lock)36"W x 24"D x 66⁵/₈"H**H107293**

365

41.0

\$2601

NOTES: Storage cabinet is standard with one fixed and two full-width adjustable shelves in top compartment; adjustable shelves can be removed. Overall storage compartment measures 31¹/₄"W x 22"D x 36¹/₈"H and will accommodate supplies, books and binders, as well as business machines and electronic equipment. Cord pass-through gap behind shelves and grommet in back of the cabinet to facilitate routing cords and reaching wall electrical outlets. Two drawer lateral file on bottom. Cabinet and lateral file lock independently.

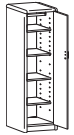

Right-hand model H107295R shown.

Wardrobe/Storage Cabinet (with core removable lock)18"W x 24"D x 66⁵/₈"H, with coat rod and 4 adjustable shelves, Hinged Right**H107295R**

225

22.9

\$191318"W x 24"D x 66⁵/₈"H, with coat rod and 4 adjustable shelves, Hinged Left**H107296L**

225

22.9

\$1913

NOTES: Unit is standard with four adjustable shelves, coat rod, and core removable lock. Shelves adjust in 2¹/₂" increments. Unit height is designed to match credenza or return plus stack-on storage height. Cabinet can be used as a wardrobe by removing four adjustable shelves. Coat rod can be removed from cabinet for storage only applications.

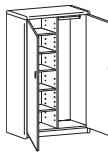

Doors open 110 degrees from closed position.

Personal Wardrobe/Storage Cabinet (with core removable lock)36"W x 24"D x 66⁵/₈"H**H10730**

335

40.6

\$2584

NOTES: Spacious design is standard with four adjustable shelves (one shelf is fixed), coat rod and core removable lock which locks both doors. Shelves adjust in 2¹/₂" increments. Unit height is designed to match credenza or return plus stack-on storage height.

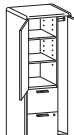

Right-hand model H107301R shown.

Personal Storage Towers24"W x 24"D x 66⁵/₈"H, Wardrobe Hinged Right, Storage Cabinet Hinged Left**H107301R**

299

27.8

\$245424"W x 24"D x 66⁵/₈"H, Wardrobe Hinged Left, Storage Cabinet Hinged Right**H107302L**

299

27.8

\$2454

NOTES: Spacious design includes a wardrobe closet, storage cabinet, and two file drawers in one compact unit. Wardrobe closet contains a coat rod. Storage cabinet includes three shelves, two are adjustable in 2¹/₂" increments. Door hinged left or right models available. File drawers operate on ball-bearing suspensions with full extension. File drawers have high sides to accept hanging folders in letter or legal size. Drawers standard with hangrails. Equipped with interchangeable core removable locks. Upper lock secures storage cabinet and wardrobe closet doors; lower lock secures file drawers. Unit height is designed to match credenza or return plus stack-on storage height.

NOTES:

- Broad family of storage components takes storage way beyond the confines of a desk drawer.
- The 18"W wardrobe/storage cabinet can be used as wardrobe by removing some or all of the adjustable shelves, coat rod can be removed for storage only.
- Locking units equipped with interchangeable core removable locks.
- See pages 316-328 for shared components.

! Keyed alike cores must be ordered separately — see model HF23B on page 746 — makes re-keying quick and easy.

HOW TO SPECIFY**Select Model Number**

H 1 0 7 2 9 3 .

Select Laminate







See page 299

N N

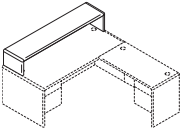

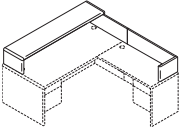
10700 SERIES™

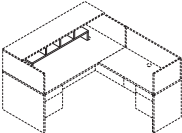
Shared Components and Accessories

	DESCRIPTION	MODEL	SHIP WEIGHT	CUBE	LIST PRICE
 	Reception Station/Transaction Counter 68 $\frac{5}{8}$ "W x 14 $\frac{5}{8}$ "D x 14 $\frac{1}{4}$ "H Intended for use with H10700 72"W double and single pedestal desk models and 72"W desk shells. NOTES: Cord management grommets on desktops serve as anchor points. Transaction counter organizer (HTCOL52) fits under/inside of transaction counter.	H107720	76	3.2	\$705
 	Reception Station for an "L" Workstation 68 $\frac{5}{8}$ "W x 75 $\frac{1}{2}$ "D x 14 $\frac{1}{4}$ "H Intended for use with a 72"W x 36"D left single pedestal desk or modular desk shell with a 42"W x 24"D right pedestal return or modular right return shell. Intended for use with a 72"W x 36"D right single pedestal desk or modular desk shell with a 42"W x 24"D left pedestal return or modular left return shell. NOTES: Cord management grommets on desktop and return serves as the anchor points for the reception station for return.	H107721R	108	4.3	\$1014
 	Transaction Counter Organizer 48 $\frac{3}{4}$ "W x 11 $\frac{1}{8}$ "D x 13"H Fits under Transaction Counter Models H107720, H107721R and H107722L. ⚠ Black only. SPECIFYING EXAMPLE: HTCOL52.P	HTCOL52	24	1.1	\$283
 <p>Base sold separately.</p>	42" Diameter Table Top NOTES: Underside of top features a factory-installed template. The template, which is trilingual, facilitates assembly of the base to the top by designating the specific attachment location for multiple base designs. Bases attach to the top with self drilling screws, no drilling is required. All top + base models are 29 $\frac{1}{2}$ "H. For Base Options see Preside® Table Base in the Tables section in the 2021 Shared Spaces Pricer. ⚠ Requires specification of a support base model shown in the Tables section in the 2021 Shared Spaces Pricer. SPECIFYING EXAMPLE: H107242.N	H107242	58	4.1	\$677

NOTES:

- "L" Reception station includes components for both the reception/transaction counter for desk and the reception station for return.
- Round table design is well suited to a variety of applications, including use in private or open plan offices.
- See pages 316-328 for shared components.

HOW TO SPECIFY

Select Model Number H 1 0 7 7 2 0	Select Laminate See page 299 N N
---	---

10700 SERIES™

Shared Components and Accessories

GSA SIN 33721

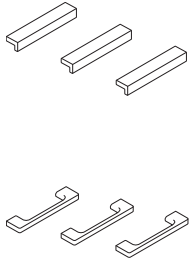
**DESCRIPTION****Field Installable Drawer/Door Handle Kits**

Linear, Black, 2-pack

Linear, Matte Chrome, 2-pack

Linear, Black, 3-pack

Linear, Matte Chrome, 3-pack

Specify Linear handles in black to coordinate with 10700 or 10500 Series™ models that ship standard with a decorative handle, such as mobile pedestals, storage cabinets and wardrobes.

Arch, Black, 2-pack

Arch, Matte Chrome, 2-pack

Arch, Black, 3-pack

Arch, Matte Chrome, 3-pack

MODEL**HLINEARA2****HLINEARC2****HLINEARA3****HLINEARC3****SHIP WEIGHT**

0.4

0.4

0.5

0.5

CUBE

0.3

0.3

0.3

0.3

LIST PRICE**\$56****\$56****\$64****\$64**

NOTES: Handles are for purchase and field installation on 10700 or 10500 Series™ desks, credenzas, returns, lateral files and modular pedestals. Instructions include mounting hardware and paper template for drilling holes.

Applications include:

- box/file and file/file pedestals = one 2-pack per pedestal
- box/box/file and pencil/media/file pedestals = one 3-pack per pedestal
- two drawer lateral file = two 2-packs per unit
- four drawer lateral file = four 2-packs per unit

The Linear and Arch handles can be attached using 96mm (approx. 3 $\frac{3}{4}$ "") or 128mm (approx. 5") hole spacing. Important note: effective January 1, 2007, the holes used for the black drawer/door handle that comes standard on several HON 10700 or 10500 Series™ products, including mobile pedestals, storage cabinet with doors, storage/file cabinet, storage cabinet/lateral file, personal wardrobe/storage cabinets, and personal storage towers, will accept the Linear and Arch handles. Units manufactured prior to January 1, 2007, have 64mm (approx. 2 $\frac{1}{2}$ "") hole spacing and will not accept the Linear and Arch handles.

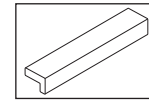
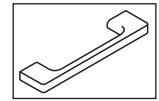
**Linear Handle****Arch Handle**

! **Must be ordered with a configurable end product. If ordered separately, not on GSA contract.**

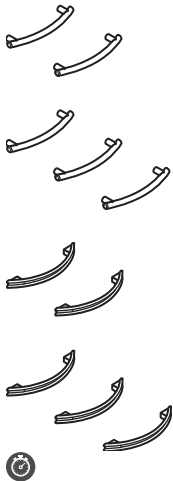
**Field Installable Drawer/Door Handle Kits**

Sweep Black, 2-pack

Sweep Satin Nickel, 2-pack

Sweep Black, 3-pack

Sweep Satin Nickel, 3-pack

Crescent Black, 2-pack

Crescent Satin Nickel, 2-pack

Crescent Black, 3-pack

Crescent Satin Nickel, 3-pack

HSWEEPA2**HSWEEPC2****HSWEEPA3****HSWEEPC3****HCRESCENTA2****HCRESCENTC2****HCRESCENTA3****HCRESCENTC3**

0.4

0.4

0.5

0.5

0.4

0.4

0.5

0.5

0.3

0.3

0.3

0.3

0.3

0.3

0.3

0.3

\$43**\$43****\$56****\$56****\$43****\$43****\$56****\$56**

NOTES: Handles are for purchase and field installation on 10700 or 10500 Series™ desks, credenzas, returns, and lateral files, as well as for the modular pedestals used with 10700 and 10500.

Applications include:

- box/file and file/file pedestals = one 2-pack per pedestal
- box/box/file and pencil/media/file pedestals = one 3-pack per pedestal
- two drawer lateral file = two 2-packs per unit
- four drawer lateral file = four 2-packs per unit

The hole spacing for the Sweep and Crescent handles is 96mm (approx. 3 $\frac{3}{4}$ ""). Important note: effective January 1, 2007, the holes used for the black drawer/door handle that comes standard on several HON 10700 or 10500 Series™ products, including mobile pedestals, storage cabinet with doors, storage/file cabinet, storage cabinet/lateral file, personal wardrobe/storage cabinets, and personal storage towers, will accept the Sweep and Crescent handles. Units manufactured prior to January 1, 2007, have 64mm (approx. 2 $\frac{1}{2}$ "") hole spacing and will not accept the Sweep and Crescent handles. Instructions include mounting hardware and paper template.

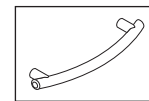
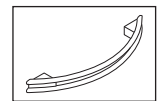
**Sweep Handle****Crescent Handle**

! **Must be ordered with a configurable end product. If ordered separately, not on GSA contract.**

NOTES:

- Field Installable Drawer/Door Handle Kits for use on 10700 Series™ desks, credenzas, returns, lateral files and storage cabinets.
- A metal template is available to facilitate field installation of the Linear, Arch, Sweep and Crescent decorative handles on 10500 and 10700 Series™ drawer fronts; order model SPLH-SYST-DRKNB.M263164.
- See pages 316-328 for shared components.

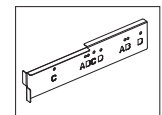
**Metal Template****HOW TO SPECIFY**

Select
Model Number

H L I N E A R A 2



10700 SERIES™

Shared Components and Accessories

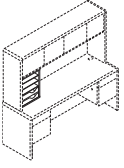
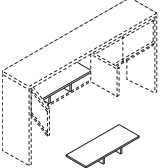
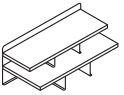
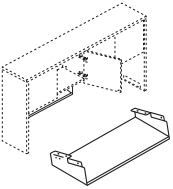
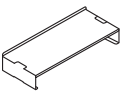
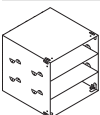
	DESCRIPTION	MODEL	SHIP WEIGHT	CUBE	LIST PRICE
	Vertical Paper Manager 14 ⁷ / ₈ "W x 10 ⁷ / ₈ "D x 19 ¹ / ₁₆ "H NOTES: Keeps papers, files, and books neatly organized and within easy reach from a seated position. Designed for desk, credenza, and return tops. Fits under stack-on storage models. Two pullout drawers and three fixed shelves. Vertical paper manager designed for desk, credenza, and return tops. Fits under stack-on storage. For additional information see the Workplace Tools section in the 2021 Shared Spaces Pricer.	HLVPM1	27	2.8	\$327
	Stacked Paper Management 32 ¹ / ₂ "W x 12 ⁵ / ₈ "D x 4 ¹ / ₄ "H NOTES: Segments and organizes stack-on and wall mount storage compartments, as well as bookcase shelves. In some cases, installation may require removing the stack-on or wall mount storage doors. For additional information see the Workplace Tools section in the 2021 Shared Spaces Pricer. ! Black only.	HLVPM2	22	1.25	\$163
 <i>Not available in two-tone laminate</i>	Desktop Storage Terrace 26 ¹ / ₂ "W x 12 ¹ / ₂ "D x 10 ¹ / ₂ "H NOTES: Keeps work-in-process, priority files, loose pages, and mail neatly organized and in view. Mixed material design comprised of sturdy laminate shelves with metal back and support panels. Not available in two-tone laminate combination or pattern laminate colors. Choose from Platinum Metallic (T1), Black (P), and Charcoal (S) for the metal components. Sized to fit in stack-on and wall mounted storage cabinets in 10500, 10700, Valido, 94000, and 38000 Series. Fits in Voi stack-on and overhead cabinets except for 48"W or smaller sliding door models. For additional information see the Workplace Tools section in the 2021 Shared Spaces Pricer. Specify: Model.Laminate.Paint SPECIFYING EXAMPLE: HLDST1.N.T1	HLDST1	24	1.1	\$306
	Hanging Paper Shelf 28 ¹ / ₁₆ "W x 11 ⁷ / ₁₆ "D x 4 ⁵ / ₁₆ "H NOTES: Maximizes worksurface space; de-clutters desktop while placing priority communications and active project folders within easy reach. Angled design allows contents to be distinguished at a glance. Mixed material styling features strong painted metal frame with a frosted shelf. Attaches quickly and easily to stack-on and wall mount storage models in the following series: 10500, 10700, Valido, 94000, and Voi (except the 36"W overhead hutch with O-legs or panel mount brackets). Not for use with 38000 Series. For additional information see the Workplace Tools section in the 2021 Shared Spaces Pricer. Specify: Model.Paint SPECIFYING EXAMPLE: HHPST1.T1	HHPST1	7	2.9	\$198
	Desktop Paper Shelf 28 ¹ / ₁₆ "W x 11 ⁵ / ₁₆ "D x 5"H NOTES: Organizer shelf provides a place and space for work-in-process and piling to keep worksurfaces neat and tidy. Convenient, scalable design with interlocking side supports allow two units to be stacked and integrated. Durable painted metal frame with a frosted shelf. Can also be used inside select overhead storage, including the following stack-on with hinged door models: 10500 and Valido 36", 42", 66", 72", 78"W and 10700 68 ⁵ / ₈ "W. For additional information see the Workplace Tools section in the 2021 Shared Spaces Pricer. Specify: Model.Paint SPECIFYING EXAMPLE: HDPS1.T1	HDPS1	7	2.9	\$198
	Storage Cube 12"W x 12"D SPECIFYING EXAMPLE: HLSL1212.P8S	HLSL1212	1	0.3	\$294

NOTES:

- See pages 316-328 for shared components.

HOW TO SPECIFY

Select Model Number H L V P M 1 . N	Select Laminate See page 299
---	--











10700 SERIES™

Shared Components and Accessories

OPEN MARKET EXCEPT AS NOTED



Icon Legend on page 19

	DESCRIPTION	MODEL	SHIP WEIGHT	CUBE	LIST PRICE
 Refer to page 106 for Center Drawer compatibility information SIN 33721	Angled Wood Center Drawer 26" x 15 ³ / ₈ " 22" x 15 ³ / ₈ "	H1526 H1522	12.0  11.0 	1.2 1.1	\$198 \$184
	NOTES: Center drawers ideal for pens, pencils and other miscellaneous storage. Feature ball-bearing slide suspension. Compatibility (where to use) information is detailed on page 106. Specify laminate for drawer. Model H1522 or H1022 can be used on peninsulas with modesty panel, model H10528. For additional information see the Workplace Tools section in the 2021 Shared Spaces Pricer.				
 SIN 33721	Polymer Center Drawer <ul style="list-style-type: none"> Color: Black. Material: ABS. Minimum clearance for mounting: 23"W x 16¹/₄"D x 2"H. Retracts on 16" ball-bearing slides. Can be used on worksurfaces with Coordinate™ Height Adjustable Bases as long as it is attached with spacer model HKBS. Can store up to 25 lbs.  Black finish only, no specification needed.	HCD1	7.0	0.5	\$111
 SIN 33721	Black Removable Lock Core Kit — see page 746. NOTES: Lock with a removable cylinder that can be interchanged as needed; allows users to access all furniture pieces in an office with a single key for convenience and security. Makes re-keying quick and easy.	HF23B	0.1	0.1	\$32
 SIN 33721	Removable Lock Core Kit Black <ul style="list-style-type: none"> For stack-on and wall mounted storage laminate models (with locks) in 10500, 10700, Valido, Voi, Concinnity, and 94000 Series. Specify quantity of each key number from 101E to 225E. Includes: 1-core, 2-keys, 1-core removal tool, and instructions. NOTES: If key number isn't specified, number will be at random.	HF27B	0.2	0.02	\$32
 SIN 33721	Back Pack Hook (10 per carton) 12"W x 14 ¹ / ₂ "D x 1 ¹ / ₂ "H NOTES: Assembly: attaches to bottom of desk with (2) screws, included.  Available in Platinum Metallic finish only, no specification needed.	HCLA65	10.0 	0.1	\$95

NOTES:

- For master key, see model HF22 on page 746.
- See pages 316-328 for shared components.

HOW TO SPECIFY

Select Model Number H 1 5 2 6 .	Select Laminate See page 299 N N
---	---



10700 SERIES™

Shared Components and Accessories



Refer to the Workplace Tools section in the 2021 Shared Spaces Pricer for additional product information

SIN 33721



DESCRIPTION	MODEL	SHIP		LIST PRICE BY PAINT GRADE	
		WEIGHT	CUBE	P1	P2
Slide-Away Keyboard Platform (Specify: Laminate)	H4022	10	0.6	\$213	
Extended Tray Slide-Away Keyboard Platform (Specify: Laminate)	HE4022	12	0.7	\$302	
Metal Keyboard and Mouse Tray (Specify paint)	H4028 OPEN MARKET	11	1.5	\$153	\$163
Metal Keyboard Tray (Specify paint)	H4029 OPEN MARKET	11	1.5	\$138	\$148
Corner Sleeve — Square Edge (22½" leading edge x 18"D) Specify paint color.	H51206	10	1.5	\$161	\$171

NOTES: For additional information see the Workplace Tools section in the 2021 Shared Spaces Pricer.



SIN 33721

DESCRIPTION	MODEL	SHIP WEIGHT	CUBE	LIST PRICE
LED Task Lights				
Articulating Desk Lamp	HLED1	1.2	6.5	\$402
Articulating Desk Lamp w/ Occupancy Sensor	HLED1OC	1.2	6.5	\$490

NOTES: For additional information see the Workplace Tools section in the 2021 Shared Spaces Pricer.



SIN 33721

Task Desk Lamp	HLED2	0.7	3.0	\$348
-----------------------	--------------	-----	-----	--------------

NOTES: For additional information see the Workplace Tools section in the 2021 Shared Spaces Pricer.



OPEN MARKET

DESCRIPTION	MODEL	SHIP WEIGHT	CUBE	LIST PRICE
LED Task Lights — for Stack-on Storage Models				
17" LED Light with Power Supply (Single)	HLED17AS ☉	1.2	0.05	\$420
31" LED Light with Power Supply (Single)	HLED31AS ☉	1.5	0.09	\$564
17" LED Light with Power Supply for Daisy-chain (Starter)	HLED17A	1.0	0.05	\$461
31" LED Light with Power Supply for Daisy-chain (Starter)	HLED31A	1.4	0.09	\$619
17" LED Light with 8" and 30" Jumper Cord for Daisy-chain (Follower)	HLED17AUO ☉	1.0	0.03	\$377
31" LED Light with 8" and 30" Jumper Cord for Daisy-chain (Follower)	HLED31AUO ☉	1.0	0.05	\$503

Undercabinet Occupancy Sensor with 1" End to End Connector	HLEDOSA ☉	0.2	0.01	\$89
---	------------------	-----	------	-------------

NOTES: To use the daisy chain application, must start with model HLED17A or HLED31A. No finish specification required. Attaches magnetically to underside of overhead storage, or attaches with provided screws or double-sided tape. Occupancy sensor attaches to a single or starter LED light and will automatically turn the light off after no motion is detected for 30 minutes. Just like all the LED light models, the occupancy sensor features a soft-touch on/off switch. LED task lights have a lifetime of 30,000 hours and have a dimmer feature that allows the user to adjust the amount of light output.



Refer to the Workplace Tools section in the 2021 Shared Spaces Pricer

OPEN MARKET

Task Light — for Stack-on Storage Models				
46½"W x 3½"D x 1½"H, for models H107318, H10734, H10733 or H10732	HH870960	12.0	1.1	\$270
34½"W x 3½"D x 1½"H, for model H107313	HH870942	10.0	0.9	\$250

NOTES: Task light and Chicago Code models see page 559. For additional information see the Workplace Tools section in the 2021 Shared Spaces Pricer.

NOTES:

- Task lights are designed for use with stack-on storage and wall mounted storage cabinets.
- Task lights feature a new slim profile and electronic ballast for increased energy efficiency.
- Task lights include a T5 bulb which contains less mercury.

10700 SERIES™

Shared Components and Accessories

GSA SIN 3372IT EXCEPT AS NOTED

ABI

Icon Legend on page 19



SIN 33721

DESCRIPTION**MODEL****SHIP WEIGHT****CUBE****LIST PRICE****Field Installable Grommet****HFLDGRMT**

0.1 Ⓢ

0.01

\$32

- Intended for use in tops and end panels to route/hide cords and in modesty panels to facilitate reaching wall electrical outlets.
- Grommet is field installable.
- Grommet shape is round.
- Includes grommet cap and sleeve.
- Grommet cap measures 3" diameter and includes a 3/4" diameter cord access hole.
- Grommet sleeve measures 2 1/2" O.D. x 3/4" thick.
- Includes instructions to locate grommet position for desks, credenzas, returns and bridges.

! Black Finish

! Requires a 2 1/2" diameter hole saw and drill for installation (not included).



SIN 33721

Field Installable Grommet**HFLDGRMT3**

0.1 Ⓢ

0.3

\$32

- Intended for use in tops and end panels to route/hide cords and in modesty panels to facilitate reaching wall electrical outlets.
- Grommet is field installable.
- Grommet shape is round.
- Includes grommet cap and sleeve.
- Grommet outside dimensions measure 3 1/2" diameter and includes two cord access holes.
- Grommet sleeve measures 3" O.D. x 1" thick.
- Includes instructions to locate grommet position for desks, credenzas, returns and bridges.

! Black Finish

! Requires a 3" diameter hole saw and drill for installation (not included).

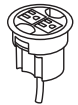
**Power Hub, 3" Grommet Mount, 6' Cord****HGRMTAC**

1.3

0.2

\$116

- Two grounded AC power outlets.
- Two cord pass-through holes in cap.
- Includes 6' cord with three-prong plug.

! Available in Black only (no color designation - Specify: HGRMTAC.X).

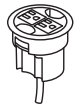

EZ

3" Round Power Grommet - 2 Outlets, 10' Cord**HGRMTAC2**

1.5

0.2

\$148

- Includes 10' cord with three-prong plug.
- Fits in 3" round grommet holes on the following product lines: Coordinate, Huddle, Motivate, all laminate and veneer casegoods series, and Systems Worksurfaces.
- Two grounded AC power outlets.
- Field installed with Plug-and-play ease.

NOTES: Power Modules will also work with standing-height applications for 10500 Series™ and Voi® desks. Optional Memory Control allows preset worksurface heights for consistency. Ships separately. Dynamic load capacity when worksurface is moving is 300 lbs.

! Available in black finish only, no specification needed.

**Power/USB Hub, 3" Grommet Mount****HGRMTUSB2**

1.3 Ⓢ

0.02

\$226

- One grounded AC power outlet with 2 USB ports.
- Two cord pass-through holes in cap.
- Includes 6' cord with three-prong plug.

! Available in black only (no color designation so use .X - Specify: HGRMTUSB2.X).

NOTES:

- The power and power/USB hub models bring the ease of plug-and-play to the desktop.
- Models HFLDGRMT3, HGRMTAC, and HGRMTUSB2 fit in 3" round grommet holes in 10700 Series™ desks, credenzas, and returns; not compatible with 10700 products with rectangle-shaped grommets.
- For additional information see the Workplace Tools section in the 2021 Shared Spaces Pricer.

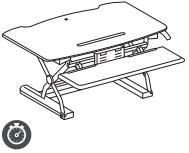
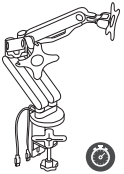
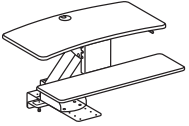
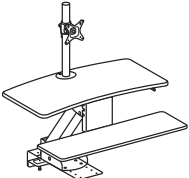
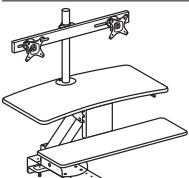
	DESCRIPTION	MODEL	SHIP WEIGHT	CUBE	LIST PRICE
	<p>Coordinate™ Portable Desktop Riser 31"D x 5"-16½"H x 35"W</p> <p>NOTES: Available in Black (BLK) or White (WHT) finish. Desktop riser dimensions (without keyboard tray): 22"D x 5"-16½"H x 35"W. Keyboard tray dimensions: 9"D x 30"W. Max loading capacity is 33 lbs for the desktop riser surface and 4 lbs for the keyboard tray. Easily transition from seated to standing positions throughout the workday. Sits atop an existing desk to create sit-to-stand functionality by raising the computer. Includes keyboard tray and surface for computer monitors. HON 5-Year Limited Warranty.</p> <p>⚠ Not intended for use on mobile workstations.</p>	HBXRISER	54.0	4.1	\$619
	<p>Dual Monitor Arm with 2 USB Ports</p> <p>NOTES: Easy adjustment. Height adjusts to 17" tall. Monitor tilt and swivel capability. Enclosed cable management. Grommet or desktop mounting. Clean appearance. In some applications the Monitor Arms may extend 12 or more inches into the worksurface. For additional information see the Workplace Tools section in the 2021 Shared Spaces Pricer. HON 5-Year Limited Warranty.</p> <p>⚠ No specification needed.</p>	HBDMAUSB	41.9	2.6	\$383
	<p>Coordinate™ Mounted Desktop Riser</p> <p>NOTES: Does not include a monitor arm and is suitable for laptops and/or monitors on their original stands.</p> <p>⚠ No specification needed.</p>	HS1100	60.0 Ⓞ	3.2	\$664
	<p>Coordinate™ Mounted Desktop Riser with Single Monitor Arm</p> <p>NOTES: Includes a monitor arm for a single monitor.</p> <p>⚠ No specification needed.</p>	HS1101	62.0 Ⓞ	3.2	\$777
	<p>Coordinate™ Mounted Desktop Riser with Dual Monitor Arm</p> <p>NOTES: Includes a monitor arm for dual monitors.</p> <p>⚠ No specification needed.</p>	HS1102	63.0 Ⓞ	3.2	\$883

NOTES FOR HS1100, HS1101, HS1102:

- These products are designed to allow the user to transition from seating position to standing position throughout the workday.
- Gas-assist lever-operated mechanism with positive stop.
- Clamp mount compatible with worksurfaces depths of 20"-30". 20" is for systems only.
- Clamp requires 3.5" of clearance along back edge of worksurface.
- Black seamless worksurfaces.
- Silver powder coated metal components.
- Lowers below worksurface level on 24" and 30"D worksurfaces.
- All models contain a large primary worksurface and a smaller keyboard / mouse surface.
- Beveled edges for sleek appearance and comfort while typing.
- Monitor arms include height, width, and swivel adjustment.

- Not for use under overhead storage, with flush mounted modesty panels, or worksurfaces thinner than 1".

⚠ Not recommended for use on mobile (castered) worksurfaces.

MOUNTING AND COMPATIBILITY FOR HS1100, HS1101, HS1102:

- This product is intended to be installed on commercial-grade worksurfaces in good condition.
- Compatible with freestanding worksurfaces 24"-30"D or panel-supported worksurfaces 24"-30"D.
- Not for use on mobile worksurfaces.

Clamp Mount

Use when 3.5" minimum overhang is available

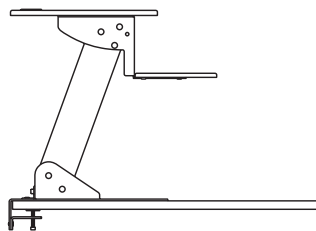

Screw Mount

Use when no overhang is available. Worksurface must be minimum 1" thick.

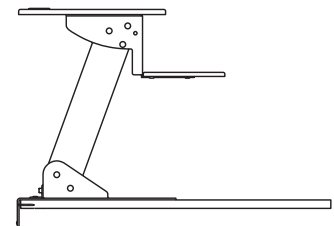

HOW TO SPECIFY

<p>Select Model Number</p> <p>HBXRISER.</p>	<p>Select Finish</p> <p>BLK Black WHT White</p> <p>BLK</p>
--	---



10700 SERIES™

Accessories

OPEN MARKET

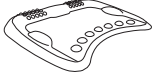
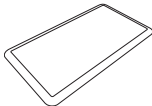
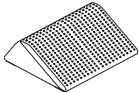

Icon Legend on page 19

	DESCRIPTION	MODEL	SHIP WEIGHT	CUBE	LIST PRICE
	Rectangle Wobble Board — Anti-Fatigue Mat 18"D x 3"H x 22¼"W ⓘ Available in Black (T) finish ONLY. Recommended weight capacity not to exceed 250 pounds. HON 5-Year Limited Warranty. SPECIFYING EXAMPLE: HVL981.T	HVL981 ⓘ	10.0 Ⓢ	0.9	\$121
	Round Wobble Board — Anti-Fatigue Mat 18½"D x 2½"H x 18½"W ⓘ Available in Black (T) finish ONLY. Recommended weight capacity not to exceed 250 pounds. HON 5-Year Limited Warranty. SPECIFYING EXAMPLE: HVL982.T	HVL982 ⓘ	5.8 Ⓢ	0.6	\$103
	Ergonomic Anti-Fatigue Mat 25"D x 2¾"H x 29⅞"W ⓘ Available in Black ONLY. No specification needed. SPECIFYING EXAMPLE: HBEAFM1	HBEAFM1	7.0	1.4	\$219
	Rectangle Anti-Fatigue Mat 20"D x ¾"H x 36"W ⓘ Available in Black ONLY. No specification needed. SPECIFYING EXAMPLE: HBAFM2036	HBAFM2036 ⓘ	5.4	0.4	\$100
	Footrest — Anti-Slip Cover 13¾"D x 5½"H x 16"W ⓘ Available in Black (T) finish ONLY. Recommended weight capacity not to exceed 250 pounds. HON 5-Year Limited Warranty. SPECIFYING EXAMPLE: HVL991.T	HVL991	7.0 Ⓢ	0.9	\$82

NOTES:

ⓘ Discontinued 1/1/21.

HOW TO SPECIFY

Select Model Number H V L 9 8 1 .	Select Finish T Black
---	---------------------------------

94000 SERIES™



94000 Series™ shown with 6550 Series Seating.

94000 SERIES™

Confident. Accomplished. Your office speaks volumes about you, and the 94000 Series says all the right things. Exceptionally crafted and solidly engineered, it's finished with warm, durable mahogany laminate — a timeless example of classic beauty and executive elegance.



FEATURES

- Traditional furniture design features solid wood trim and plinth style bases.
- From gleaming brass fixtures to raised accent moldings, details make this desk a standout.
- Our comprehensive selection makes it easy to create a complete executive look.
- It's all about the amenities — like pull out writing surfaces for extra room when you need it and central locking center drawers on all desks.

94000 SERIES™

Typicals



Icon Legend on page 19

Components used are listed on pages 334-339. Order components individually. Other configurations are possible, including various sizes of some components.

QTY	DESCRIPTION	MODEL	LIST PRICE	PRICE EXTENSION
1	Double Pedestal Desk 72"W x 36"D x 29½"H	H94271	\$2,517	\$2,517
1	Credenza with Kneespace 72"W x 24"D x 29½"H	H94243	\$2,102	\$2,102
1	Stack-on Storage 70"W x 16⅞"D x 37"H	H94234	\$1,515	\$1,515
TOTAL:			\$6,134	

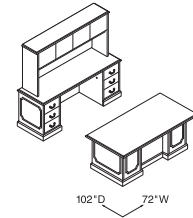

DESK WORKSTATION
72"W x 102"D

QTY	DESCRIPTION	MODEL	LIST PRICE	PRICE EXTENSION
1	Double Pedestal Desk 72"W x 36"D x 29½"H	H94271	\$2,517	\$2,517
1	Credenza with Doors 72"W x 24"D x 29½"H	H94244	\$2,427	\$2,427
1	Hutch with Wire Mesh Doors 70"W x 16⅞"D x 48¾"H	H94235	\$2,815	\$2,815
TOTAL:			\$7,759	

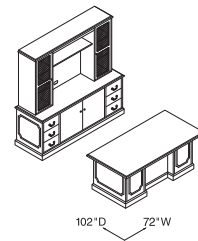

DESK WORKSTATION
72"W x 102"D

QTY	DESCRIPTION	MODEL	LIST PRICE	PRICE EXTENSION
1	Laminate Rectangle Top with Traditional Edge Detail 72"W x 36"D	HTLC3672T	\$1,092	\$1,092
1	Laminate Traditional Panel Base 29½"H with HTLC3672T Top	HTLT72	\$762	\$762
1	Credenza with Doors 72"W x 24"D x 29½"H	H94244	\$2,427	\$2,427
1	Stack-on Storage 70"W x 16⅞"D x 37"H	H94234	\$1,515	\$1,515
TOTAL:			\$5,796	

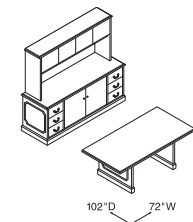
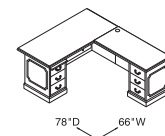

TABLE WORKSTATION
72"W x 102"D

QTY	DESCRIPTION	MODEL	LIST PRICE	PRICE EXTENSION
1	Single Pedestal Desk, Left 66"W x 30"D x 29½"H	H94284L	\$2,070	\$2,070
1	Right Return – box/file 48"W x 24"D x 29½"H	H94215R	\$1,413	\$1,413
TOTAL:			\$3,483	



DESK "L" WORKSTATION – RIGHT
66"W x 78"D



Icon Legend on page 19

94000 SERIES™ Typicals

Components used are listed on pages 334-339. Order components individually. Other configurations are possible, including various sizes of some components.

QTY	DESCRIPTION	MODEL	LIST PRICE	PRICE EXTENSION
1	Single Pedestal Desk, Right 66"W x 30"D x 29½"H	H94283R	\$2,070	\$2,070
1	Left Return - box/file 48"W x 24"D x 29½"H	H94216L	\$1,413	\$1,413
1	Stack-on-Storage 76"W x 16⅞"D x 37"H	H94237	\$1,577	\$1,577
TOTAL:			\$5,060	

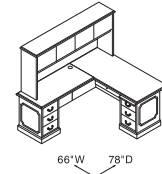

DESK "L" WORKSTATION - LEFT
66"W x 78"D

QTY	DESCRIPTION	MODEL	LIST PRICE	PRICE EXTENSION
1	Single Pedestal Desk, Left 72"W x 36"D x 29½"H	H94286L	\$2,203	\$2,203
1	Bridge 48"W x 24"D x 29½"H	H94270	\$831	\$831
1	Single Pedestal Credenza, Right 72"W x 24"D x 29½"H	H94245R	\$1,816	\$1,816
1	Stack-on Storage 70"W x 16⅞"D x 37"H	H94234	\$1,515	\$1,515
TOTAL:			\$6,365	

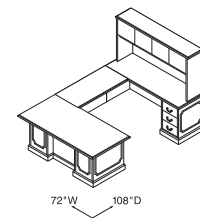

DESK "U" WORKSTATION - RIGHT
72"W x 108"D

QTY	DESCRIPTION	MODEL	LIST PRICE	PRICE EXTENSION
1	Single Pedestal Desk, Right 72"W x 36"D x 29½"H	H94285R	\$2,203	\$2,203
1	Bridge 48"W x 24"D x 29½"H	H94270	\$831	\$831
1	Credenza w/Lateral, Left 72"W x 24"D x 29½"H	H94248L	\$2,063	\$2,063
1	Stack-on Storage w/Glass Doors 70"W x 16⅞"D x 37"H	H94236	\$2,026	\$2,026
TOTAL:			\$7,123	

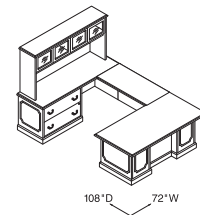

DESK "U" WORKSTATION - LEFT
72"W x 108"D

94000 SERIES™ Laminate Wood Desks

GSA SIN 33721



Icon Legend on page 19

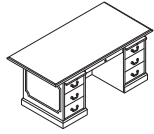

DESCRIPTION

Double Pedestal Desk 2-2 — Box/File
72"W x 36"D x 29½"H

**FULL WIDTH
OVERHANG**

7"

MODEL

H94271

**SHIP
WEIGHT**

307

CUBE

52.9

**LIST
PRICE**

\$2517

NOTES: 7" conference overhang on approach side (provides kneespace for visitors), and a 6¾" conference overhang on each end. Convenient pull out writing shelf above pedestal provides added workspace. Center drawer features central locking (locks all drawers).

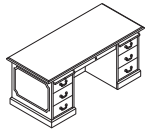

Double Pedestal Desk 2-2 — Box/File
66"W x 30"D x 29½"H
60"W x 30"D x 29½"H

1"

H94276

340

42.8

\$2453

1"

H94251

284

39.0

\$2368

NOTES: Convenient pull out writing shelf above pedestal provides added workspace. Center drawer features central locking (locks all drawers).

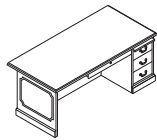

Single Pedestal Desk — Box/File
72"W x 36"D x 29½"H, Right
66"W x 30"D x 29½"H, Right
72"W x 36"D x 29½"H, Left
66"W x 30"D x 29½"H, Left

7"

H94285R

275

54.0

\$2203

1"

H94283R

233

42.8

\$2070

7"

H94286L

275

54.0

\$2203

1"

H94284L

233

42.8

\$2070

NOTES: Convenient pull out writing shelf above pedestal provides added workspace. Center drawer features central locking (locks all drawers).

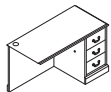

Model H94215R shown

Return — Box/File
48"W x 24"D x 29½"H, Right
42"W x 24"D x 29½"H, Right
48"W x 24"D x 29½"H, Left
42"W x 24"D x 29½"H, Left

H94215R

154

24.9

\$1413

H94211R

146

22.1

\$1309

H94216L

154

24.9

\$1413

H94212L

146

22.1

\$1309

NOTES: Drawers lock. One round cord grommet in the top. One cord pass-through grommet in the modesty panel to facilitate reaching wall electrical outlets.

⚠ Not designed to be used freestanding.

NOTES:

- 18th century elegance, 21st century engineering.
- Traditional furniture applications include state and local government, military bases, banks, and attorney offices.
- Tops are premium abrasion- and stain-resistant high pressure, high-gloss laminate over durable 1⅛" solid core high-performance particleboard.
- Solid wood edge profile.
- Antique brass drawer pulls; hand-applied raised decorative molding, and plinth style base.
- Pullout reference/writing shelf is standard on all desk pedestals.
- Desk, credenza, and return drawers are 5-sided construction, which allows easy drawer alignment or replacement of drawer fronts.
- Center drawer on desks equipped with built-in pencil tray and central locking (locks all drawers).
- Drawers operate on full extension, ball-bearing suspensions to ensure smooth, quiet, long-lasting operation.
- File drawer design includes integrated hangrails for side-to-side letter or legal filing; and front-to-back for letter filing.
- Locking units equipped with interchangeable core removable locks.
- 94000 Series™ products produced after 10/26/98 have been improved with a thicker top. Joining with older products before that date may cause misalignment.
- Adjustable hex leveling glides allow floor-standing furniture to be easily leveled without lifting the unit; glides have ¾" adjustable range.



⚠ Keyed alike cores must be ordered separately — see model HF23B on page 746 — makes re-keying quick and easy.

HOW TO SPECIFY

Select Model Number	Select Laminate
H 9 4 2 7 1	NN Mahogany

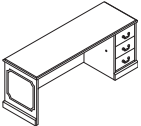
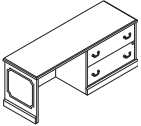
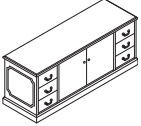
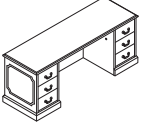

94000 SERIES™ Laminate Wood Desks

	DESCRIPTION	MODEL	SHIP WEIGHT	CUBE	LIST PRICE
 	Bridge (single ped. desk to single ped. credenza or credenza with lateral) 48"W x 24"D x 29½"H, (clear inside depth is 22½"D) 42"W x 24"D x 29½"H, (clear inside depth is 22½"D)	H94270 H94260	85 76	4.3 4.3	\$831 \$768
	NOTES: One cord pass-through grommet in top center of modesty panel to facilitate reaching wall electrical outlets. Kneespace of desk is limited to 24¾"W if bridge is used with 66"W single pedestal desk.				
 Model H94245R shown	Credenza, Single Pedestal — Box/File 72"W x 24"D x 29½"H, Right 72"W x 24"D x 29½"H, Left	H94245R H94246L	230 230	36.0 36.0	\$1816 \$1816
	NOTES: Drawers lock. One cord pass-through grommet in top center of modesty panel to facilitate reaching wall electrical outlets. See pages 336-337 for optional Overhead Hutch and Stack-on Storage.				
 Model H94247R shown	Credenza with 36" Lateral 72"W x 24"D x 29½"H, Right 72"W x 24"D x 29½"H, Left	H94247R H94248L	239 239	36.0 36.0	\$2063 \$2063
	NOTES: Lateral file drawers lock. See pages 336-337 for optional Overhead Hutch and Stack-on Storage.				
 Model H94244 shown	Credenza with Doors — Box/File 72"W x 24"D x 29½"H	H94244	313	36.0	\$2427
	NOTES: All drawers lock. Doors are non-locking. One removable shelf (38¾"W x 13¾"D). Shelf is not adjustable. See pages 336-337 for optional Overhead Hutch and Stack-on Storage.				
 Model H94243 shown	Credenza with Kneespace — Box/File 72"W x 24"D x 29½"H	H94243	253	36.0	\$2102
	NOTES: All drawers lock. One cord pass-through grommet in top center of modesty panel to facilitate reaching wall electrical outlets. See pages 336-337 for optional Overhead Hutch and Stack-on Storage.				

NOTES:

- 18th century elegance, 21st century engineering.
- Tops are premium abrasion- and stain-resistant high pressure, high-gloss laminate over durable 1½" solid core high-performance particleboard.
- Solid wood edge profile.
- Antique brass drawer pulls; hand-applied raised decorative molding, and plinth style base.
- Pullout reference/writing shelf is standard on all desk pedestals.
- Desk, credenza, and return drawers are 5-sided construction, which allows easy drawer alignment or replacement of drawer fronts.
- Center drawer on desks equipped with built-in pencil tray and central locking (locks all drawers).
- Drawers operate on full extension, ball-bearing suspensions to ensure smooth, quiet, long-lasting operation.
- File drawer design includes integrated hangrails for side-to-side letter or legal filing; and front-to-back for letter filing.
- Locking units equipped with interchangeable core removable locks.
- 94000 Series™ products produced after 10/26/98 have been improved with a thicker top. Joining with older products before that date may cause misalignment.
- Adjustable hex leveling glides allow floor-standing furniture to be easily leveled without lifting the unit; glides have ¾" adjustable range.

! Keyed alike cores must be ordered separately — see model HF23B on page 746 — makes re-keying quick and easy.

HOW TO SPECIFY

Select Model Number	Select Laminate
H 9 4 2 4 5 R .	NN Mahogany
	NN

94000 SERIES™

Laminate Wood Desks

GSA SIN 33721

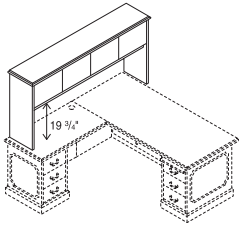

Icon Legend on page 19

**DESCRIPTION****Stack-on Storage for 78" D "L" Shaped Workstation**

76"W x 16 1/8"D x 37"H (Accepts Back Enclosure H107358, Fabric Tackboard H90035 and Task Light HH870960.)

MODEL**H94237****SHIP WEIGHT**

198

CUBE

18.4

LIST PRICE**\$1577****Stack-on Storage for 78" D "L" Shaped Workstation, Locking**

76"W x 16 1/8"D x 37"H (Accepts Back Enclosure H107358, Fabric Tackboard H90035 and Task Light HH870960.)

H94237K

198

18.4

\$1661

NOTES: Spans the total dimension of "L" shaped layouts comprised of a 48"W return attached to a 30"D single pedestal desk (78"D); or a 42"W return attached to 36"D single pedestal desk (78"D). For vertical paper manager model HLVPM1, see page 339.

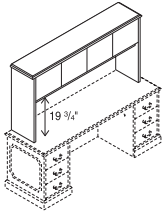
**Stack-on Storage**

70"W x 16 1/8"D x 37"H (Accepts Back Enclosure H10738, Fabric Tackboard H90034 and Task Light HH870960.)

H94234

175

18.0

\$1515**Stack-on Storage, Locking**

70"W x 16 1/8"D x 37"H (Accepts Back Enclosure H10738, Fabric Tackboard H90034 and Task Light HH870960.)

H94234K

175

18.0

\$1599

NOTES: For use on 72"W credenza models or on 72"D "L" shaped workstations comprised of a 30"D single pedestal desk and a 42"W return. Inside storage contains two compartments each sized: 31 3/4"W x 12 1/8"D x 12"H. Vertical paper manager, model HLVPM1, fits under stack-on storage. See page 339.

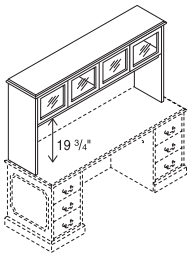
**Stack-on Storage with Glass Doors**

70"W x 16 1/8"D x 37"H (Accepts Back Enclosure H10738 and Fabric Tackboard H90034.) (Use Task Light HH870960, see page 337)

H94236

171

18.0

\$2026

NOTES: Elegant wood-framed, clear glass door design. For use on 72"W credenza models or on 72"D "L" shaped workstations comprised of a 30"D single pedestal desk and a 42"W return. No lock option for glass doors. For vertical paper manager model HLVPM1, see page 339.

NOTES:

- Stack-on storage equipped with self-closing, adjustable hinged doors.
- Stack-on storage design includes valance to hide task light.
- Vertical paper manager keeps papers, files and books organized and within easy reach from a seated position. Fits under stack-on storage models. See page 339.
- Stacked paper management segments and organizes stack-on storage compartments and bookcase shelves. Unit can be used in models H94327, H94234 and H94236. In some cases, installation may require removing the stack-on storage doors. See page 325.
- For a variety of work-in-process paper management tools, see pages 289-290.
- Overhead Hutch features one cord pass-through grommet located in bottom center of back panel.
- Overhead Hutch is not designed to accept task light.
- Removable lock core kit for locking stack-on storage is model HF27B. See page 746.

HOW TO SPECIFY**Select Model Number**

H 9 4 2 3 7 .

Select Laminate



NN Mahogany

N N

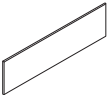

Icon Legend on page 19

94000 SERIES™ Laminate Wood Desks

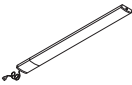
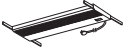
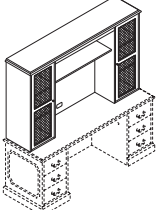
	DESCRIPTION	MODEL	COM	SHIP WEIGHT	CUBE	LIST PRICE
 <p>18⁵/₈"H</p>	Back Enclosure for Stack-on Storage 76"W model #H94237 70"W model #H94234 or H94236	H107358 H10738		34.0 31.0	1.30 1.30	\$273 \$251
	NOTES: Specify laminate with a single designator. Non-tackable surface. Feature full width 1 ¹ / ₈ " slot at bottom to facilitate routing cords and reaching wall electrical outlets. SPECIFYING EXAMPLE: H107358.N					
 <p>18"H</p>	Tackboards for use with Stack-on Storage Back Enclosures (Back Enclosures must be ordered separately.) 71 ¹ / ₂ "W for 76"W model #H94237 Stack-on with #H107358 Enclosure 65 ¹⁵ / ₁₆ "W for 70"W model #H94234 or H94236 Stack-on with #H10738 Enclosure	H90035 H90034	2.0 2.0	13.0 11.0	2.80 2.00	\$326 \$310
	NOTES: Specify fabric selection from pages 25-26. Upcharges may apply to premium fabric grades. Tackboards are sized ³ / ₄ " narrower than respective stack-on storage back enclosure, allowing ³ / ₈ " each side to route task light cords. Attached to back enclosure using latch & hook tape provided. ⓘ Disperse (DISP) fabric not available on sizes wider than 60". SPECIFYING EXAMPLE: H930035.APN15					
 <p>OPEN MARKET</p>	LED Task Lights — For Stack-on and Wall Mounted Storage Cabinets 17" LED Light with Power Supply (Single) 31" LED Light with Power Supply (Single)	HLED17AS ⓘ HLED31AS ⓘ		1.2 ⓘ 1.5 ⓘ	0.05 0.09	\$420 \$564
	NOTES: No finish specification required. Attaches magnetically to underside of overhead storage, or attaches with provided screws or double-sided tape. Occupancy sensor attaches to a single or starter LED light and will automatically turn the light off after no motion is detected for 30 minutes. Just like all the LED light models, the occupancy sensor features a soft-touch on/off switch. LED task lights have a lifetime of 50,000 hours and have a dimmer feature that allows the user to adjust the amount of light output.					
 <p>Refer to the Workplace Tools section in the 2021 Shared Spaces Pricer</p> <p>OPEN MARKET</p>	Recessed Task Light 46 ¹ / ₂ "W x 3 ¹ / ₁₆ "D for Models H94234, H94234K, H94236, H94237 and H94237K. Chicago code version (with fused plug)	HH870960 HH870960CH		12.0 ⓘ 12.0 ⓘ	1.10 1.10	\$270 \$337
	NOTES: For additional information see the Workplace Tools section in the 2021 Shared Spaces Pricer.					
	Overhead Hutch w/Wire Mesh Doors 70"W x 16 ¹ / ₈ "D x 48 ³ / ₄ "H	H94235		260.0	43.30	\$2815
	NOTES: Each side storage compartment contains: 1-lower opening 16 ¹ / ₄ "W x 13 ¹¹ / ₁₆ "D x 15 ⁷ / ₈ "H and 2-upper openings 16 ¹ / ₄ "W x 13 ⁷ / ₁₆ "D x 14 ³ / ₈ "H. Clearance for computer, etc.: 32 ¹⁵ / ₁₆ "W x 12 ⁵ / ₈ "D x 31 ³ / ₄ "H. No lock option for mesh doors. ⓘ 14 ³ / ₄ "H center shelf does not adjust. Not designed to accept task light.					

NOTES:

- Stack-on storage equipped with self-closing, adjustable hinged doors.
- Stack-on storage design includes valance to hide task light.
- Vertical paper manager keeps papers, files and books organized and within easy reach from a seated position. Fits under stack-on storage models. See page 339.
- Stacked paper management segments and organizes stack-on storage compartments and bookcase shelves. Unit can be used in models H94237, H94234 and H94236. In some cases, installation may require removing the stack-on storage doors. See page 325.
- For a variety of work-in-process paper management tools, see pages 289-290.
- Overhead Hutch features one cord pass-through grommet located in bottom center of back panel.
- ⓘ Overhead Hutch is not designed to accept task light.
- ⓘ Removable lock core kit for locking stack-on storage is model HF27B. See page 746.

HOW TO SPECIFY

Select Model Number H 9 4 2 3 5	Select Laminate NN Mahogany
---	---------------------------------------

94000 SERIES™

Laminate Wood Desks

GSA SIN 33721

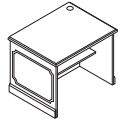

Icon Legend on page 19

**DESCRIPTION**

Computer Work Table with cord grommet
36"W x 30"D x 29½"H

NOTES: One removable shelf (32⅓"W x 12⅝"D).

MODEL**H94226****SHIP WEIGHT**

130

CUBE

23.8

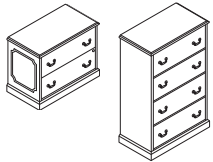
LIST PRICE**\$1147****Lateral Files (with core removable lock)**

37½"W x 20½"D x 29½"H — two drawer
37½"W x 20½"D x 59⅞"H — four drawer

NOTES: High capacity file storage. Includes hangrails; mechanical interlock inhibits the extension of more than one drawer at a time. Two drawer design is equipped with a counterweight.

H94223

172

17.7

\$1450**H94229**

300

34.0

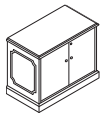
\$2488**Storage Cabinet (with core removable lock)**

37½"W x 20½"D x 29½"H

H94291

165

16.7

\$1300

NOTES: Bookcase hutch H94210 can be used with H94291. One adjustable shelf, adjusts in 1¼" increments.

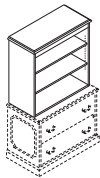
**Bookcase Hutch**

35¾"W x 14⅝"D x 37"H, (3 shelves; 2 adjustable, includes bottom of unit)
Designed to be used on model H94223 lateral file or model H94291 storage cabinet.

NOTES: One cord pass-through grommet located at bottom center of back panel. Two adjustable shelves, adjust in 1¼" increments.

H94210

95

14.0

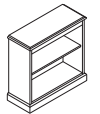
\$972**Bookcase**

35¾"W x 14⅝"D x 35½"H, 2-Shelf
35¾"W x 14⅝"D x 49⅞"H, 3-Shelf
35¾"W x 14⅝"D x 64"H, 4-Shelf
35¾"W x 14⅝"D x 78¼"H, 5-Shelf

NOTES: Fixed shelves.

H94221

100

14.8

\$907**H94222**

130

20.6

\$1016**H94224**

160

26.3

\$1153**H94225**

200

32.3

\$1264**Bookcase with Glass Doors**

35¾"W x 14⅝"D x 49⅞"H

H94220

155

20.6

\$1620

NOTES: Upscale design brings order, utility and a touch of elegance to the traditional office. Wood-framed, clear glass doors with hinges provide easy access to interior. Three fixed shelves provide spacious storage. Shelf measures 32¾"W x 11¾"D. Bookcase with glass doors brings order, utility and a touch of elegance to the traditional office.

ⓘ Doors are not designed to lock.

**Storage Cabinet/Lateral File (with core removable lock)**

37½"W x 24"D x 66½"H

H94435

355

44.4

\$2652

NOTES: Standard with one fixed and two full-width adjustable shelves in top compartment; adjustable shelves can be removed. Overall storage compartment measures 33¾"W x 22"D x 36⅞"H and will accommodate supplies, books and binders, as well as business machines and electronic equipment. Cord pass-through gap behind shelves and grommet in back of the cabinet to facilitate routing cords and reaching wall electrical outlets. Two drawer lateral file on bottom. Lateral file comes with mechanical interlock and hangrails. Cabinet and lateral file lock independently. Unit height is designed to match credenza or return plus stack-on storage height or the two drawer lateral file or storage cabinet plus the bookcase hutch height (66½"H).

Doors open 110 degrees from closed position.

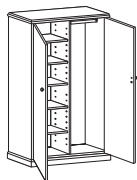
**Personal Wardrobe/Storage Cabinet (with core removable lock)**

37½"W x 24"D x 66½"H

H94430

351

44.4

\$2607

NOTES: Spacious design is standard with four adjustable shelves (one shelf is fixed) plus a generous wardrobe section with a coat rod. Shelves adjust in 2½" increments. One lock secures both doors. Unit height is designed to match credenza plus stack-on storage height or the two drawer lateral file or storage cabinet plus the bookcase hutch height (66½"H). Personal wardrobe/storage cabinet is standard with four adjustable shelves (one shelf is fixed) plus a generous wardrobe section with a coat rod.

NOTES:

- File drawers accommodate letter and legal width side-to-side filing, and letter-width front-to-back filing; use hanging folders with a maximum overall height of 9⅜".
- Adjustable hex leveling glides allow floor-standing furniture to be easily leveled without lifting the unit; glides have ¾" adjustable range.
- For conference table options, see the Preside® table tops and bases in the Tables section in the 2021 Shared Spaces Pricer. Order edge option "T" for 94000 Desks edge compatibility.
- Removable lock core kit – HF23B – allows multiple units to be keyed alike. See page 746.

HOW TO SPECIFY

Select
Model Number

H 9 4 2 2 6









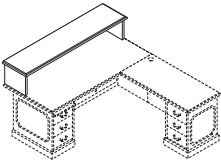

Select
Laminate

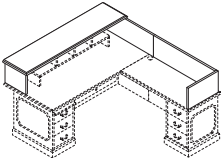
NN Mahogany

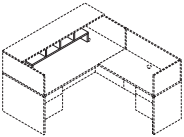
N N

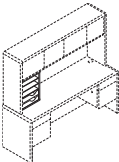

94000 SERIES™ Laminate Wood Desks

	DESCRIPTION	MODEL	SHIP WEIGHT	CUBE	LIST PRICE
 	Reception Station/Transaction Counter 71 ³ / ₄ "W x 16 ¹ / ₈ "D x 14 ¹ / ₄ "H Designed for use with 72"W single pedestal desk models H94285R or H94286L. NOTES: Reception station/transaction counter has traditional-styled decorative molding on the approach side.	H94720	75	2.6	\$946
	Reception Station for an "L" Workstation 71 ³ / ₄ "W x 82 ³ / ₄ "D x 14 ¹ / ₄ "H Designed for use with 72"W single pedestal desk H94286L and 48"W return H94215R (shown) Designed for use with 72"W single pedestal desk H94285R and 48"W return H94216L. NOTES: Reception station for "L" workstation includes components for both the reception/transaction counter for desk and the reception station for return.	H94721R H94722L	100	4.0	\$1146 \$1146
 Model H94721R shown 	Transaction Counter Organizer 48 ³ / ₄ "W x 11 ¹ / ₈ "D x 13"H Fits under Transaction Counter on models H94720, H94721R and H94722L. NOTES: Transaction Counter Organizer model HTCOL52 fits under/inside of transaction counter.  Black only. SPECIFYING EXAMPLE: HTCOL52.P	HTCOL52	24	1.1	\$283
 	Vertical Paper Manager 14 ⁷ / ₈ "W x 10 ⁷ / ₈ "D x 19 ¹ / ₁₆ "H NOTES: Keeps papers, files, and books neatly organized and within easy reach from a seated position. Designed for desk, credenza, and return tops. Fits under stack-on storage models. Two pullout drawers and three fixed shelves. NOTES: For additional information see the Workplace Tools section in the 2021 Shared Spaces Pricer. SPECIFYING EXAMPLE: HLVPM1.N	HLVPM1	27	2.8	\$327
 Not available in two-tone laminate	Angled Wood Center Drawer 26" x 15 ⁵ / ₈ " 22" x 15 ³ / ₈ " NOTES: Specify laminate. For additional information see the Workplace Tools section in the 2021 Shared Spaces Pricer. SPECIFYING EXAMPLE: H1526.N	H1526 H1522	12  11 	1.2 1.1	\$198 \$184
 Refer to page 106 for Center Drawer compatibility information					

NOTES:

- For conference table options, see the Preside® table tops and bases in the Tables section in the 2021 Shared Spaces Pricer. Order edge option "T" for 94000 Desks edge compatibility.

HOW TO SPECIFY

Select Model Number H 9 4 7 2 0	Select Laminate NN Mahogany
---	---------------------------------------

94000 SERIES™

Accessories

GSA SIN AS NOTED

ABI

Icon Legend on page 19

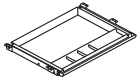

OPEN MARKET

DESCRIPTION**Polymer Center Drawer**

- Color: Black.
- Material: ABS.
- Minimum clearance for mounting: 23"W x 16¼"D x 2"H.
- Retracts on 16" ball-bearing slides.
- Can be used on worksurfaces with Coordinate™ Height Adjustable Bases as long as it is attached with spacer model HKBS.
- Can store up to 25 lbs.

! Black finish only, no specification needed.

MODEL**HCD1****SHIP WEIGHT**

7.0

CUBE

0.5

LIST PRICE**\$111**

Refer to the Workplace Tools section in the 2021 Shared Spaces Pricer for additional product information

Slide-Away Keyboard Platform (Specify: Laminate)**H4022**10.0 **Ⓢ**

0.6

\$213**Extended Tray Slide-Away Keyboard Platform** (Specify: Laminate)**HE4022**12.0 **Ⓢ**

0.7

\$302

NOTES: For additional information see the Workplace Tools section in the 2021 Shared Spaces Pricer.

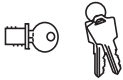
SIN 33721**SIN 33721****Black Removable Lock Core Kit (for laminate products)****HF23B**0.1 **Ⓢ**

0.1

\$32

- Specify quantity of each key number from 101E-225E.
- Includes: 1-core, 2-keys, 1-core removal tool, and instructions.

NOTES: If key number isn't specified, number will be at random. Core matches manufactured lock on laminate product but can be used with metal casegoods product.







NOTES:

- For conference table options, see the Preside® table tops and bases in the Tables section in the 2021 Shared Spaces Pricer. Order edge option "T" for 94000 Desks edge compatibility.

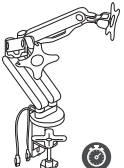
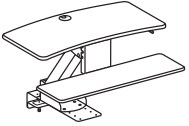
HOW TO SPECIFY

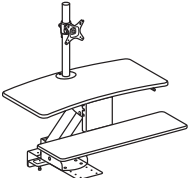
Select
Model Number

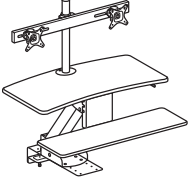
H	C	D	1
---	---	---	---

	DESCRIPTION	MODEL	SHIP WEIGHT	CUBE	LIST PRICE
	Coordinate™ Portable Desktop Riser 31"D x 5"-16½"H x 35"W NOTES: Available in Black (BLK) or White (WHT) finish. Desktop riser dimensions (without keyboard tray): 22"D x 5"-16½"H x 35"W. Keyboard tray dimensions: 9"D x 30"W. Max loading capacity is 33 lbs for the desktop riser surface and 4 lbs for the keyboard tray. Easily transition from seated to standing positions throughout the workday. Sits atop an existing desk to create sit-to-stand functionality by raising the computer. Includes keyboard tray and surface for computer monitors. HON 5-Year Limited Warranty.	HBXRISER	54.0	4.1	\$619
	Dual Monitor Arm with 2 USB Ports NOTES: Easy adjustment. Height adjusts to 17" tall. Monitor tilt and swivel capability. Enclosed cable management. Grommet or desktop mounting. Clean appearance. In some applications the Monitor Arms may extend 12 or more inches into the worksurface. For additional information see the Workplace Tools section in the 2021 Shared Spaces Pricer. HON 5-Year Limited Warranty.	HBDMAUSB	41.9	2.6	\$383
	Coordinate™ Mounted Desktop Riser NOTES: Does not include a monitor arm and is suitable for laptops and/or monitors on their original stands.	HS1100	60.0 	3.2	\$664
	Coordinate™ Mounted Desktop Riser with Single Monitor Arm NOTES: Includes a monitor arm for a single monitor.	HS1101	62.0 	3.2	\$777
	Coordinate™ Mounted Desktop Riser with Dual Monitor Arm NOTES: Includes a monitor arm for dual monitors.	HS1102	63.0 	3.2	\$883

NOTES FOR HS1100, HS1101, HS1102:

- These products are designed to allow the user to transition from seating position to standing position throughout the workday.
- Gas-assist lever-operated mechanism with positive stop.
- Clamp mount compatible with worksurfaces depths of 20"-30". 20" is for systems only.
- Clamp requires 3.5" of clearance along back edge of worksurface.
- Black seamless worksurfaces.
- Silver powder coated metal components.
- Lowers below worksurface level on 24" and 30"D worksurfaces.
- All models contain a large primary worksurface and a smaller keyboard / mouse surface.
- Beveled edges for sleek appearance and comfort while typing.
- Monitor arms include height, width, and swivel adjustment.

- Not for use under overhead storage, with flush mounted modesty panels, or worksurfaces thinner than 1".

 Not recommended for use on mobile (castered) worksurfaces.

MOUNTING AND COMPATIBILITY FOR HS1100, HS1101, HS1102:

- This product is intended to be installed on commercial-grade worksurfaces in good condition.
- Compatible with freestanding worksurfaces 24"-30"D or panel-supported worksurfaces 24"-30"D.
- Not for use on mobile worksurfaces.

Clamp Mount

Use when 3.5" minimum overhang is available

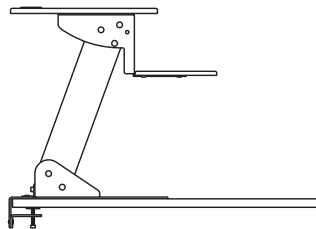

Screw Mount

Use when no overhang is available. Worksurface must be minimum 1" thick.

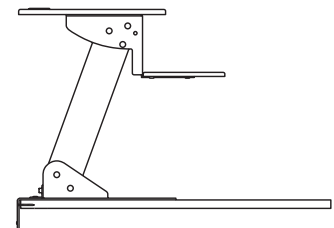

HOW TO SPECIFY

Select Model Number	Select Finish	
	BLK Black WHT White	
HBXRISER.	BLK	



94000 SERIES™

Accessories

OPEN MARKET

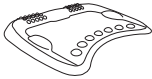
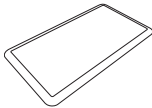
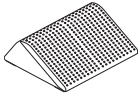

Icon Legend on page 19

	DESCRIPTION	MODEL	SHIP WEIGHT	CUBE	LIST PRICE
	Rectangle Wobble Board — Anti-Fatigue Mat 18"D x 3"H x 22¼"W ⓘ Available in Black (T) finish ONLY. Recommended weight capacity not to exceed 250 pounds. HON 5-Year Limited Warranty. SPECIFYING EXAMPLE: HVL981.T	HVL981 ⓘ	10.0 Ⓢ	0.9	\$121
	Round Wobble Board — Anti-Fatigue Mat 18½"D x 2½"H x 18½"W ⓘ Available in Black (T) finish ONLY. Recommended weight capacity not to exceed 250 pounds. HON 5-Year Limited Warranty. SPECIFYING EXAMPLE: HVL982.T	HVL982 ⓘ	5.8 Ⓢ	0.6	\$103
	Ergonomic Anti-Fatigue Mat 25"D x 2¾"H x 29⅞"W ⓘ Available in Black ONLY. No specification needed. SPECIFYING EXAMPLE: HBEAFM1	HBEAFM1	7.0	1.4	\$219
	Rectangle Anti-Fatigue Mat 20"D x ¾"H x 36"W ⓘ Available in Black ONLY. No specification needed. SPECIFYING EXAMPLE: HBAFM2036	HBAFM2036 ⓘ	5.4	0.4	\$100
	Footrest — Anti-Slip Cover 13¾"D x 5½"H x 16"W ⓘ Available in Black (T) finish ONLY. Recommended weight capacity not to exceed 250 pounds. HON 5-Year Limited Warranty. SPECIFYING EXAMPLE: HVL991.T	HVL991	7.0 Ⓢ	0.9	\$82

NOTES:

ⓘ Discontinued 1/1/21.

HOW TO SPECIFY

Select Model Number H V L 9 8 1 .	Select Finish T Black
---	---------------------------------



Mentor® Double Pedestal Desk with Volt® Task Chair and Brigade® Bookcases.

MENTOR®

Users appreciate the clean lines and rounded corners of the Mentor desk from HON. Stylish detailing and soft edges create an attractive, contemporary desk that's very user-friendly. Performance and durability make Mentor ideal for use in intensive environments. Featuring central locking drawers and integrated wire management, Mentor works hard for hard-working professionals.



FEATURES

- Durable baked enamel finish will hold up beautifully under years of daily use.
- Functional features like central locking center drawers and integrated wire management.
- Sturdy steel construction and heavy-duty reinforced frames.
- Mentor's performance and durability make it ideal for intensive use environments.
- Half-round legs and radius top corners are excellent for high-traffic areas.
- Arch drawer handles match Flagship® laterals, pedestals and towers.

MENTOR[®] ORDERING INFORMATION

FINISHES AVAILABILITY

L1 LAMINATES CODES

Woodgrain

◆ Bourbon Cherry	H
◆ Cognac	COGN
◆ Florence Walnut	LFW1
◆ Harvest	C
◆ Kingswood Walnut	LK11
◆ Mahogany	N
◆ Mocha	MOCH
◆ Natural Maple	D
◆ Shaker Cherry	F
◆ Sterling Ash	LSA1

Solid

◆ Black	P
◆ Charcoal	S
◆ Designer White	LDW1
◆ Loft	LOFT

Patterned

◆ Sheer Mesh	A5
◆ Silver Mesh	B9
◆ Steel Mesh	A9
◇ Canyon Zephyr	K9
◇ Desert Zephyr	K8
◇ Shadow Zephyr	K1
◆ Gray	G2
◆ Grey Tigris	L6
◇ White	G1
◆ Whitestone	K4

PAINTS CODES

P1

◆ Black	P
◆ Brownstone	P7D
◆ Charcoal	S
◆ Fossil	P28
◆ Greige	T5
◆ Light Gray	Q
◆ Loft	LOFT
◆ Muslin	T3
◆ Putty	L
◆ Shadow *	SHDW
◆ Titanium	P8T

NOTE: Vinyl edge and grommets match specified chassis color.

• STEEL DESKS

SPECIFY: Model Number.
Top Laminate
Paint Color

EXAMPLE: H88976.NS

◆◆◆ For lead time information see page 19.

* De-emphasized



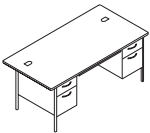
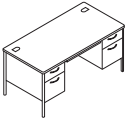
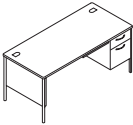
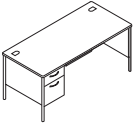
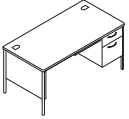
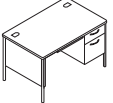

	DESCRIPTION	MODEL	SHIP WEIGHT	CUBE	LIST PRICE
	Double Pedestal Desk with Center Drawer (6" overhang on 3 sides) — 2/2 72"W x 36"D x 29½"H, Chrome Leg and Pull NOTES: Model H88976 requires Model H386560N 60"W Stack-on as top of desk extends over end panels.	H88976	203	37.7	\$1779
	Double Pedestal Desk with Center Drawer — 2/2 60"W x 30"D x 29½"H, Chrome Leg and Pull	H88962	178	26.7	\$1474
	Single Pedestal Desk with Center Drawer – Right, box/file 66"W x 30"D x 29½"H, Chrome Leg and Pull	H88265R	162	29.2	\$1339
	Single Pedestal Desk with Center Drawer – Left, box/file 66"W x 30"D x 29½"H, Chrome Leg and Pull	H88266L	162	29.2	\$1339
	Single Pedestal Desk with Center Drawer – Right, box/file 60"W x 30"D x 29½"H, Chrome Leg and Pull	H88263R	145	26.7	\$1271
	Single Pedestal Desk with Center Drawer – Right, box/file 48"W x 30"D x 29½"H, Chrome Leg and Pull	H88251R	130	21.6	\$1205

NOTES:

- Leg available in Chrome.
- Attractive radius leg design and arched drawer pulls.
- Legs ship unattached.
- 3/4 height modesty panels.
- Rounded edge desk top with soft feel-vinyl edge.
- Wire management grommets in desk tops and pedestals.
- Laminate tops are constructed of 1½" thick particleboard.
- 13½" deep, central locking center drawer equipped with HON "One Key" interchangeable lock cores.
- High-sided file drawers accept hanging files without hangrails.
- Full extension steel ball-bearing suspensions on file drawers for easy access to all contents.
- Reinforced double "O" frame inner structure keeps desk solid and sturdy for years of use.
- Box drawers equipped with 3/4 extension steel ball-bearing suspensions and one divider.
- Vinyl edge and grommets match specified chassis color.
- All interior drawer bodies are gray, pre-painted steel.

! Keyed alike cores must be ordered separately — see page 746.

HOW TO SPECIFY



Select Model Number 	Select Laminate See page 344 	Select Paint Color See page 344 
---	---	--

MENTOR® Steel Desks

GSA SIN 33721



Icon Legend on page 19

	DESCRIPTION	MODEL	SHIP WEIGHT	CUBE	LIST PRICE
	Double Pedestal Credenza with Kneespace, box/file (non-locking) 60"W x 24"D x 29½"H, Chrome Leg and Pull	H88231	149	21.8	\$1455
	Return, Right, box/file (non-locking) 42"W x 24"D x 29½"H, Chrome Leg and Pull	H88235R	92	15.5	\$936
	Return, Left, box/file (non-locking) 42"W x 24"D x 29½"H, Chrome Leg and Pull	H88236L	92	15.5	\$936

NOTES:

- Leg available in Chrome.
- Attractive radius leg design and arched drawer pulls.
- Legs ship unattached.
- ¾ height modesty panels.
- Rounded edge desk top with soft feel-vinyl edge.
- Wire management grommets in desk tops and pedestals.
- Laminate tops are constructed of 1/8" thick particleboard.
- High-sided file drawers accept hanging files without hangrails.
- Full extension steel ball-bearing suspensions on file drawers for easy access to all contents.
- Reinforced double "O" frame inner structure keeps desk solid and sturdy for years of use.
- Box drawers equipped with ¾ extension steel ball-bearing suspensions and one divider.
- Vinyl edge and grommets match specified chassis color.
- All interior drawer bodies are gray, pre-painted steel.

HOW TO SPECIFY

Select
Model Number

H 8 8 2 3 1 .

Select
Laminate

See page 344

N .

Select
Paint Color

See page 344

S

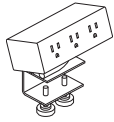

Model HPWRMOD3WC shown

DESCRIPTION**Power Modules**

3 Receptacles with Worksurface Clamp

2 Receptacles 2 USB with Worksurface Clamp

- 6' power cord with standard three-prong plug.
- Under-worksurface mounting bracket models work with any top that has a 5" x 5" square clearance.
- Worksurface clamp models work on any top with a 4" overhang.
- UL Listed.

NOTES: For additional information see the Workplace Tools section in the 2021 Shared Spaces Pricer.

- ! Color finish coordinates with HON's Charcoal or White. Specify *STRM* for Storm or *SNW* for Snow when ordering. Example: *HPWRMOD3WC.STRM*.

MODEL**SHIP WEIGHT****CUBE****LIST PRICE****HPWRMOD3WC**

2.3 Ⓞ

0.2

\$310**HPWRMOD2WC**

2.3 Ⓞ

0.2

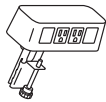
\$496**Power & Data Center**

2 Receptacles 2 Data Accessory

- Standard with two receptacles and openings for two data ports.
- 6' power cord with standard three-prong plug.
- Fits on any worksurface with a 4" overhang.
- UL Listed.

NOTES: For additional information see the Workplace Tools section in the 2021 Shared Spaces Pricer.

- ! Color finish coordinates with HON's Loft. Specify *LOFT* when ordering. Example: *HCOMDOME2.LOFT*.

HCOMDOME2

2.5 Ⓞ

0.2

\$296**Vertebrae**

NOTES: 30"H x 3 1/8"W x 1 1/2"D. Ships unassembled. For additional information see the Workplace Tools section in the 2021 Shared Spaces Pricer.

- ! Clear finish. Specify "X" for finish option.

SPECIFYING EXAMPLE: HMPVWM28.X**HMPVWM28**

3.0

0.3

\$223**Storage Cube**

12"W x 12"D

SPECIFYING EXAMPLE: HLSL1212.P8S**HLSL1212**

1.0

0.3

\$294**HOW TO SPECIFY**Select
Model Number

H P W R M O D 3 W C

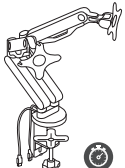
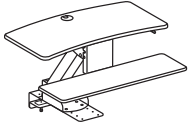
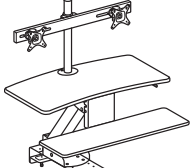
	DESCRIPTION	MODEL	SHIP WEIGHT	CUBE	LIST PRICE
	Coordinate™ Portable Desktop Riser 31"D x 5"-16½"H x 35"W NOTES: Available in Black (BLK) or White (WHT) finish. Desktop riser dimensions (without keyboard tray): 22"D x 5"-16½"H x 35"W. Keyboard tray dimensions: 9"D x 30"W. Max loading capacity is 33 lbs for the desktop riser surface and 4 lbs for the keyboard tray. Easily transition from seated to standing positions throughout the workday. Sits atop an existing desk to create sit-to-stand functionality by raising the computer. Includes keyboard tray and surface for computer monitors. HON 5-Year Limited Warranty. ⓘ Not intended for use on mobile workstations.	HBXRISER	54.0	4.1	\$619
	Dual Monitor Arm with 2 USB Ports NOTES: Easy adjustment. Height adjusts to 17" tall. Monitor tilt and swivel capability. Enclosed cable management. Grommet or desktop mounting. Clean appearance. In some applications the Monitor Arms may extend 12 or more inches into the worksurface. For additional information see the Workplace Tools section in the 2021 Shared Spaces Pricer. HON 5-Year Limited Warranty. ⓘ No specification needed.	HBDMAUSB	41.9	2.6	\$383
	Coordinate™ Mounted Desktop Riser NOTES: Does not include a monitor arm and is suitable for laptops and/or monitors on their original stands. ⓘ No specification needed.	HS1100	60.0 ⓘ	3.2	\$664
	Coordinate™ Mounted Desktop Riser with Single Monitor Arm NOTES: Includes a monitor arm for a single monitor. ⓘ No specification needed.	HS1101	62.0 ⓘ	3.2	\$777
	Coordinate™ Mounted Desktop Riser with Dual Monitor Arm NOTES: Includes a monitor arm for dual monitors. ⓘ No specification needed.	HS1102	63.0 ⓘ	3.2	\$883

NOTES FOR HS1100, HS1101, HS1102:

- These products are designed to allow the user to transition from seating position to standing position throughout the workday.
- Gas-assist lever-operated mechanism with positive stop.
- Clamp mount compatible with worksurfaces depths of 20"-30". 20" is for systems only.
- Clamp requires 3.5" of clearance along back edge of worksurface.
- Black seamless worksurfaces.
- Silver powder coated metal components.
- Lowers below worksurface level on 24" and 30"D worksurfaces.
- All models contain a large primary worksurface and a smaller keyboard / mouse surface.
- Beveled edges for sleek appearance and comfort while typing.
- Monitor arms include height, width, and swivel adjustment.

- Not for use under overhead storage, with flush mounted modesty panels, or worksurfaces thinner than 1".

ⓘ Not recommended for use on mobile (castered) worksurfaces.

MOUNTING AND COMPATIBILITY FOR HS1100, HS1101, HS1102:

- This product is intended to be installed on commercial-grade worksurfaces in good condition.
- Compatible with freestanding worksurfaces 24"-30"D or panel-supported worksurfaces 24"-30"D.
- Not for use on mobile worksurfaces.

Clamp Mount

Use when 3.5" minimum overhang is available

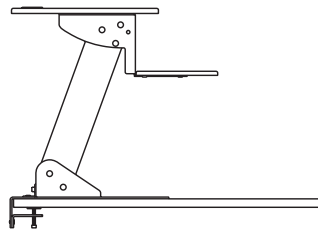

Screw Mount

Use when no overhang is available. Worksurface must be minimum 1" thick.

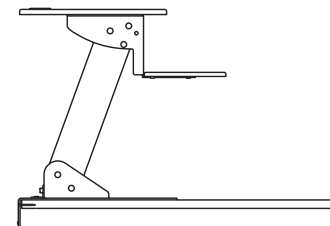

HOW TO SPECIFY

Select Model Number



HBXRISER.

Select Finish

BLK Black
WHT White

BLK

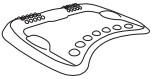
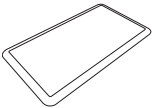
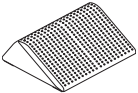

	DESCRIPTION	MODEL	SHIP WEIGHT	CUBE	LIST PRICE
	Rectangle Wobble Board — Anti-Fatigue Mat 18"D x 3"H x 22¼"W ⓘ Available in Black (T) finish ONLY. Recommended weight capacity not to exceed 250 pounds. HON 5-Year Limited Warranty. SPECIFYING EXAMPLE: HVL981.T	HVL981 ⓘ	10.0 Ⓔ	0.9	\$121
	Round Wobble Board — Anti-Fatigue Mat 18½"D x 2⅝"H x 18½"W ⓘ Available in Black (T) finish ONLY. Recommended weight capacity not to exceed 250 pounds. HON 5-Year Limited Warranty. SPECIFYING EXAMPLE: HVL982.T	HVL982 ⓘ	5.8 Ⓔ	0.6	\$103
	Ergonomic Anti-Fatigue Mat 25"D x 2¾"H x 29⅞"W ⓘ Available in Black ONLY. No specification needed. SPECIFYING EXAMPLE: HBEAFM1	HBEAFM1	7.0	1.4	\$219
	Rectangle Anti-Fatigue Mat 20"D x ¾"H x 36"W ⓘ Available in Black ONLY. No specification needed. SPECIFYING EXAMPLE: HBAFM2036	HBAFM2036 ⓘ	5.4	0.4	\$100
	Footrest — Anti-Slip Cover 13¾"D x 5½"H x 16"W ⓘ Available in Black (T) finish ONLY. Recommended weight capacity not to exceed 250 pounds. HON 5-Year Limited Warranty. SPECIFYING EXAMPLE: HVL991.T	HVL991	7.0 Ⓔ	0.9	\$82

NOTES:

ⓘ Discontinued 1/1/21.

HOW TO SPECIFY

Select Model Number	Select Finish
H V L 9 8 1 .	T Black
	T

NOTES

METRO CLASSIC



Metro Classic Desk shown with Ignition® Seating.

METRO CLASSIC

The Metro Classic is a forward-thinking flashback that marries '60s styling with today's technology. This handsomely built collection offers excellent performance for the price — with best-in-class construction, easy-care laminate tops, built-in wire management and more. If you're looking for iconic style that lasts, you'll find it in Metro Classic.



FEATURES

- Retro-styled, but with up-to-date amenities, this classic reflects the enduring Modernist office designs of the 1960s.
- With tubular steel legs painted to match the desk body, Metro Classic gives you a clean look from top to bottom.
- Pedestals feature Tru-Fit mitered drawer fronts for precision alignment when closed.
- Contract-grade, multi-ply laminate stands up to scratches, spills, stains and boiling liquids.
- Recessed plastic drawer handles are color-matched to HON core paint colors.
- All drawers lock by securing the center drawer; lock core can be changed as security needs require.

METRO CLASSIC

ORDERING INFORMATION

FINISHES AVAILABILITY

L1 LAMINATES/EDGE BAND

COLOR CODES

Woodgrain

- ◆ Bourbon Cherry/
Bourbon Cherry **H**
- ◆ Cognac/Cognac **COGN**
- ◆ Florence Walnut/
Florence Walnut **LFW1**
- ◆ Harvest/Harvest **C**
- ◆ Kingswood Walnut/
Kingswood Walnut **LK11**
- ◆ Mahogany/Mahogany **N**
- ◆ Mocha/Mocha **MOCH**
- ◆ Natural Maple/
Natural Maple **D**
- ◆ Shaker Cherry/
Shaker Cherry **F**
- ◆ Sterling Ash/
Sterling Ash **LSA1**

Solid

- ◆ Black/Black **P**
- ◆ Charcoal/Charcoal **S**
- ◆ Designer White/
Designer White **LDW1**
- ◆ Loft/Loft **LOFT**

Patterned

- ◆ Sheer Mesh/Muslin **A5**
- ◆ Silver Mesh/Loft **B9**
- ◆ Steel Mesh/Charcoal **A9**
- ◆ Canyon Zephyr/
Greige **K9**
- ◆ Desert Zephyr/
Greige **K8**
- ◆ Shadow Zephyr/
Loft **K1**
- ◆ Gray/Matches Paint Color **G2**
- ◆ Grey Tigris/Greige **L6**
- ◆ White/Matches Paint
Color **G1**
- ◆ Whitestone/Matches Paint
Color **K4**

PAINTS CODES

P1

- ◆ Black **P**
- ◆ Brownstone **P7D**
- ◆ Charcoal **S**
- ◆ Fossil **P28**
- ◆ Greige **T5**
- ◆ Light Gray **Q**
- ◆ Loft **LOFT**
- ◆ Muslin **T3**
- ◆ Putty **L**
- ◆ Shadow * **SHDW**
- ◆ Titanium **P8T**

• STEEL DESKS

SPECIFY: Model Number.
Top Laminate
Paint Color

EXAMPLE: HP3276.NS



◆◆◆ For lead time information see page 19.

* De-emphasized

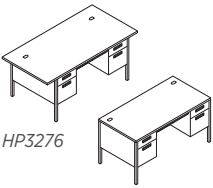
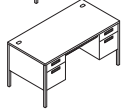

Icon Legend on page 19

METRO CLASSIC Steel Desks

	DESCRIPTION	MODEL	SHIP WEIGHT	CUBE	LIST PRICE
 <p>HP3276</p>	Double Pedestal — 2/2 (locking) 72"W x 36"D x 29½"H (6" overhang on 3 sides) NOTES: HP3276 requires Model H386560N 60"W Stack-on as top of desk extends over end panels.	HP3276	218	37.7	\$1695
	60"W x 30"D x 29½"H (Non-Locking, 24"D chassis) (6" overhang on approach side only)	HP3261	165	26.7	\$1188
	60"W x 30"D x 29½"H (locking)	HP3262	186	26.7	\$1385
 <p>HP3262</p>	Single Pedestal (locking) 66"W x 30"D x 29½"H — 2R 66"W x 30"D x 29½"H — 2L 48"W x 30"D x 29½"H — 2R	HP3265R	167	29.2	\$1279
		HP3266L	167	29.2	\$1279
		HP3251R	142	21.6	\$1140
	Return, Right — box/file (non-locking) 42"W x 24"D x 29½"H	HP3235R	95	15.5	\$895
	Return, Left — box/file (non-locking) 42"W x 24"D x 29½"H	HP3236L	95	15.5	\$895

NOTES:

- Two wire grommets in desk, credenza, and return tops.
- 3/4 height modesty panels.
- Legs shipped unattached.
- Color of pulls and grommets match paint selection for core colors.
- "Tru-fit" mitered drawer fronts for better visual alignment.
- Color of legs match paint selection.
- Central locking center drawer standard, with HON "One Key" interchangeable lock cores.
- High-sided file drawers accept hanging files without hangrails.
- Full extension steel ball-bearing suspensions on file drawers for easy access to all contents.
- Box drawers equipped with 3/4 extension steel ball-bearing suspensions and one divider.
- Reinforced, double "O" frame inner structure keeps desk solid and sturdy for years of use.
- All interior drawer bodies are gray pre-painted steel.
- 38000 Series™ stack-on units can be used on Metro desks and credenzas.

ⓘ Keyed alike cores ordered separately — see page 746.

HOW TO SPECIFY

<p>Select Model Number</p> <p>HP3276</p>	<p>Select Laminate</p> <p>See page 352 Not specified for models H386566N, H386560N and H386548N</p> <p>N</p>	<p>Select Paint Color</p> <p>See page 352</p> <p>S</p>
---	--	---

METRO CLASSIC

Steel Desks

GSA SIN 33721

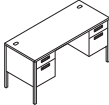
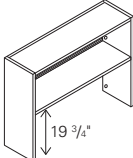
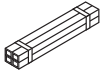
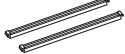

Icon Legend on page 19

	DESCRIPTION	MODEL	SHIP WEIGHT	CUBE	LIST PRICE
	Credenza w/Kneespace — 2/2 (non-locking) 60"W x 24"D x 29½"H Accommodates optional HD2 or HD8 center drawer. NOTES: Non-locking.	HP3231	165.0	21.8	\$1385
	Stack-on Full Clearance without Doors 66"W x 13½"D x 34¾"H 60"W x 13½"D x 34¾"H 48"W x 13½"D x 34¾"H NOTES: Interior is 12¾"H. Specify: Paint color. For additional 38000 Series™ Stack-on accessory items, see pages 378-380. HP3276 requires Model H386560N 60"W Stack-on as top of desk extends over end panels.	H386566N H386560N H386548N	68.0 64.0 53.0	6.3 5.7 4.7	\$881 \$816 \$745
	Chrome Leg Packs — Field Installable 4 pk-29½"H	HC14	7.2	0.2	\$132
	Double-Rail Hanging File Racks — 2 Pack (for side-to-side) ⓘ Gray only	H519495	0.5	0.5	\$34

NOTES:

- Two wire grommets in desk, credenza, and return tops.
- ¾ height modesty panels.
- Legs shipped unattached.
- Color of pulls and grommets match paint selection for core colors.
- "Tru-fit" mitered drawer fronts for better visual alignment.
- Color of legs match paint selection.
- Central locking center drawer standard, with HON "One Key" interchangeable lock cores.
- High-sided file drawers accept hanging files without hangrails.
- Full extension steel ball-bearing suspensions on file drawers for easy access to all contents.
- Box drawers equipped with ¾ extension steel ball-bearing suspensions and one divider.
- Reinforced, double "O" frame inner structure keeps desk solid and sturdy for years of use.
- All interior drawer bodies are gray pre-painted steel.
- 38000 Series™ stack-on units can be used on Metro desks and credenzas.

ⓘ Keyed alike cores ordered separately — see page 746.

HOW TO SPECIFY**Select Model Number**

HP3231

Select Laminate

See page 352

Not specified for models H386566N, H386560N and H386548N

N

Select Paint Color

See page 352

S

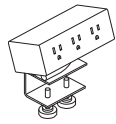

Model HPWRMOD3WC shown

DESCRIPTION**Power Modules**

3 Receptacles with Worksurface Clamp

2 Receptacles 2 USB with Worksurface Clamp

- 6' power cord with standard three-prong plug.
- Under-worksurface mounting bracket models work with any top that has a 5" x 5" square clearance.
- Worksurface clamp models work on any top with a 4" overhang.
- UL Listed.

! Color finish coordinates with HON's Charcoal or White. Specify *STRM* for Storm or *SNW* for Snow when ordering.
Example: HPWRMOD3WC.STRM.

MODEL**SHIP WEIGHT****CUBE****LIST PRICE****HPWRMOD3WC**

2.3 Ⓢ

0.2

\$310**HPWRMOD2WC**

2.3 Ⓢ

0.2

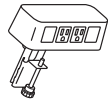
\$496**Power & Data Center**

2 Receptacles 2 Data Accessory

- Standard with two receptacles and openings for two data ports.
- 6' power cord with standard three-prong plug.
- Fits on any worksurface with a 4" overhang.
- UL Listed.

! Color finish coordinates with HON's Loft. Specify *LOFT* when ordering. Example: HCOMDOME2.LOFT.

HCOMDOME2

2.5 Ⓢ

0.2

\$296**Vertebrae**

NOTES: 30"H x 3 1/8"W x 1 1/2"D. Ships unassembled.

! Clear finish. Specify "X" for finish option.

SPECIFYING EXAMPLE: HMPVWM28.X**HMPVWM28**

3.0

0.3

\$223**Storage Cube**

12"W x 12"D

SPECIFYING EXAMPLE: HLSL1212.P8S**HLSL1212**

1.0

0.3

\$294**HOW TO SPECIFY**Select
Model Number

H P W R M O D 3 W C

METRO CLASSIC

Accessories

OPEN MARKET

Icon Legend on page 19

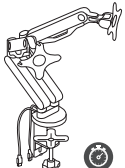
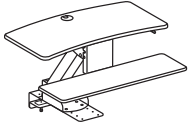
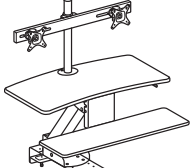
	DESCRIPTION	MODEL	SHIP WEIGHT	CUBE	LIST PRICE
	Coordinate™ Portable Desktop Riser 31"D x 5"-16½"H x 35"W NOTES: Available in Black (BLK) or White (WHT) finish. Desktop riser dimensions (without keyboard tray): 22"D x 5"-16½"H x 35"W. Keyboard tray dimensions: 9"D x 30"W. Max loading capacity is 33 lbs for the desktop riser surface and 4 lbs for the keyboard tray. Easily transition from seated to standing positions throughout the workday. Sits atop an existing desk to create sit-to-stand functionality by raising the computer. Includes keyboard tray and surface for computer monitors. HON 5-Year Limited Warranty. ⓘ Not intended for use on mobile workstations.	HBXRISER	54.0	4.1	\$619
	Dual Monitor Arm with 2 USB Ports NOTES: Easy adjustment. Height adjusts to 17" tall. Monitor tilt and swivel capability. Enclosed cable management. Grommet or desktop mounting. Clean appearance. In some applications the Monitor Arms may extend 12 or more inches into the worksurface. For additional information see the Workplace Tools section in the 2021 Shared Spaces Pricer. HON 5-Year Limited Warranty. ⓘ No specification needed.	HBDMAUSB	41.9	2.6	\$383
	Coordinate™ Mounted Desktop Riser NOTES: Does not include a monitor arm and is suitable for laptops and/or monitors on their original stands. ⓘ No specification needed.	HS1100	60.0 ⓘ	3.2	\$664
	Coordinate™ Mounted Desktop Riser with Single Monitor Arm NOTES: Includes a monitor arm for a single monitor. ⓘ No specification needed.	HS1101	62.0 ⓘ	3.2	\$777
	Coordinate™ Mounted Desktop Riser with Dual Monitor Arm NOTES: Includes a monitor arm for dual monitors. ⓘ No specification needed.	HS1102	63.0 ⓘ	3.2	\$883

NOTES FOR HS1100, HS1101, HS1102:

- These products are designed to allow the user to transition from seating position to standing position throughout the workday.
- Gas-assist lever-operated mechanism with positive stop.
- Clamp mount compatible with worksurfaces depths of 20"-30". 20" is for systems only.
- Clamp requires 3.5" of clearance along back edge of worksurface.
- Black seamless worksurfaces.
- Silver powder coated metal components.
- Lowers below worksurface level on 24" and 30"D worksurfaces.
- All models contain a large primary worksurface and a smaller keyboard / mouse surface.
- Beveled edges for sleek appearance and comfort while typing.
- Monitor arms include height, width, and swivel adjustment.

- Not for use under overhead storage, with flush mounted modesty panels, or worksurfaces thinner than 1".

ⓘ Not recommended for use on mobile (castered) worksurfaces.

MOUNTING AND COMPATIBILITY FOR HS1100, HS1101, HS1102:

- This product is intended to be installed on commercial-grade worksurfaces in good condition.
- Compatible with freestanding worksurfaces 24"-30"D or panel-supported worksurfaces 24"-30"D.
- Not for use on mobile worksurfaces.

Clamp Mount

Use when 3.5" minimum overhang is available

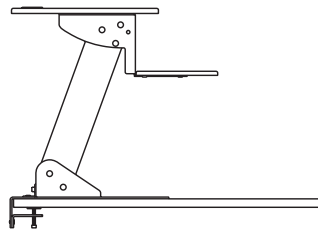

Screw Mount

Use when no overhang is available. Worksurface must be minimum 1" thick.

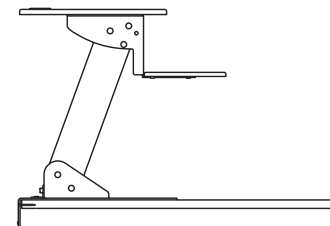

HOW TO SPECIFY

Select Model Number



HBXRISER.

Select Finish

BLK Black
WHT White

BLK

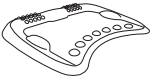
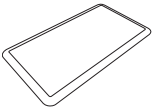
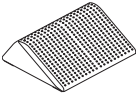

	DESCRIPTION	MODEL	SHIP WEIGHT	CUBE	LIST PRICE
	Rectangle Wobble Board — Anti-Fatigue Mat 18"D x 3"H x 22½"W ⓘ Available in Black (T) finish ONLY. Recommended weight capacity not to exceed 250 pounds. HON 5-Year Limited Warranty. SPECIFYING EXAMPLE: HVL981.T	HVL981 Ⓢ	10.0 Ⓢ	0.9	\$121
	Round Wobble Board — Anti-Fatigue Mat 18½"D x 2⅝"H x 18½"W ⓘ Available in Black (T) finish ONLY. Recommended weight capacity not to exceed 250 pounds. HON 5-Year Limited Warranty. SPECIFYING EXAMPLE: HVL982.T	HVL982 Ⓢ	5.8 Ⓢ	0.6	\$103
	Ergonomic Anti-Fatigue Mat 25"D x 2¾"H x 29⅞"W ⓘ Available in Black ONLY. No specification needed. SPECIFYING EXAMPLE: HBEAFM1	HBEAFM1	7.0	1.4	\$219
	Rectangle Anti-Fatigue Mat 20"D x ¾"H x 36"W ⓘ Available in Black ONLY. No specification needed. SPECIFYING EXAMPLE: HBAFM2036	HBAFM2036 Ⓢ	5.4	0.4	\$100
	Footrest — Anti-Slip Cover 13¾"D x 5½"H x 16"W ⓘ Available in Black (T) finish ONLY. Recommended weight capacity not to exceed 250 pounds. HON 5-Year Limited Warranty. SPECIFYING EXAMPLE: HVL991.T	HVL991	7.0 Ⓢ	0.9	\$82

NOTES:

Ⓢ Discontinued 1/1/21.

HOW TO SPECIFY

Select Model Number	Select Finish
H V L 9 8 1 .	T Black
	T

NOTES

34000 SERIES



34000 Series shown with 500 Series Lateral and Volt® Seating.

34000 SERIES

The 34000 Series gets high marks in the classroom — or any environment requiring a heavy-duty metal desk that knows how to look good. The square Chrome legs and brushed Aluminum handles look clean and uncomplicated. The Tru-Fit mitered drawer fronts line up perfectly every time. Desk models offer central locking, so all the drawers can be secured with the turn of a single key. And with HON's best-in-class construction, 34000 Series will stand up to years of use.



FEATURES

- Legs are Chrome for a contemporary accent.
- Pedestals feature Tru-Fit mitered drawer fronts that align precisely when closed.
- All drawers lock by securing the center drawer; lock core can be changed as security needs require.
- Contract-grade, multi-ply laminate worksurface stands up to scratches, spills, stains and boiling liquids.
- Brushed Aluminum drawer handles match HON vertical file handles.

34000 SERIES ORDERING INFORMATION

FINISHES AVAILABILITY

L1 LAMINATES/EDGE BAND

COLOR CODES

Woodgrain

- ◆ Bourbon Cherry/
Bourbon Cherry **H**
- ◆ Cognac/Cognac **COGN**
- ◆ Florence Walnut/
Florence Walnut **LFW1**
- ◆ Harvest/Harvest **C**
- ◆ Kingswood Walnut/
Kingswood Walnut **LK11**
- ◆ Mahogany/Mahogany **N**
- ◆ Mocha/Mocha **MOCH**
- ◆ Natural Maple/
Natural Maple **D**
- ◆ Shaker Cherry/
Shaker Cherry **F**
- ◆ Sterling Ash/
Sterling Ash **LSA1**

Solid

- ◆ Black/Black **P**
- ◆ Charcoal/Charcoal **S**
- ◆ Designer White/
Designer White **LDW1**
- ◆ Loft/Loft **LOFT**

Patterned

- ◆ Sheer Mesh/Muslin **A5**
- ◆ Silver Mesh/Loft **B9**
- ◆ Steel Mesh/Charcoal **A9**
- ◆ Canyon Zephyr/Greige **K9**
- ◆ Desert Zephyr/Greige **K8**
- ◆ Shadow Zephyr/Loft **K1**
- ◆ Gray/Matches Paint Color **G2**
- ◆ Grey Tigris/Grey Tigris **L6**
- ◆ White/Matches Paint
Color **G1**
- ◆ Whitestone/Matches Paint
Color **K4**

PAINTS CODES

P1

- ◆ Black **P**
- ◆ Brownstone **P7D**
- ◆ Charcoal **S**
- ◆ Fossil **P28**
- ◆ Greige **T5**
- ◆ Light Gray **Q**
- ◆ Loft **LOFT**
- ◆ Muslin **T3**
- ◆ Putty **L**
- ◆ Shadow * **SHDW**
- ◆ Titanium **P8T**

• STEEL DESKS

SPECIFY: Model Number.
Top Laminate
Paint Color



EXAMPLE: HP3276.NS

◆◆◆ For lead time information see page 19.

* De-emphasized

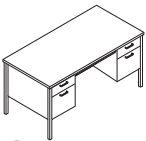
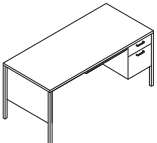
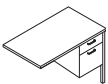

34000 SERIES Steel Desks

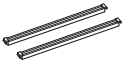
	DESCRIPTION	MODEL	SHIP WEIGHT	CUBE	LIST PRICE
	Double Pedestal — 2/2 (locking) 60"W x 30"D x 29½"H	H34962	162.0	26.7	\$1323
	Single Pedestal, box/file (locking) 66"W x 30"D x 29½"H, Right 66"W x 30"D x 29½"H, Left 48"W x 30"D x 29½"H, Right 45¼"W x 24"D x 29½"H, Right	H34973R H34974L H34251 H34002R	161.0 161.0 115.0 83.0	29.2 29.2 21.6 16.6	\$1143 \$1143 \$1009 \$863
	Return, Box/File (non-locking) 42"W x 24"D x 29½"H, Right 42"W x 24"D x 29½"H, Left NOTES: Returns are for use with 66"W Single Pedestal Desks.	H34834R H34835L	89.0 89.0	15.5 15.5	\$760 \$760
	Credenza with Kneespace — 2/2 (non-locking) 60"W x 24"D x 29½"H ! Accommodates optional HD2 or HD8 center drawer.	H34480	160.0	21.8	\$1330
	Chrome Leg Packs — Field Installable 4 pk-29½"H	HC14	7.2 Ⓢ	0.2	\$132
	Double-Rail Hanging File Racks — 2 Pack (for side-to-side) ! Gray only	H519495	0.5	0.5	\$34

NOTES:

- "Tru-fit" mitered drawer fronts for better visual alignment.
- 3/4 height modesty panels.
- Chrome legs shipped unattached.
- Laminate tops.
- Central locking center drawer standard, with HON "One Key" interchangeable lock cores.
- Full extension steel ball-bearing suspensions on file drawers for easy access to all contents.
- High-sided file drawers accept hanging files without hangrails.
- Box drawers equipped with 3/4 extension steel ball-bearing suspensions and one divider.
- Reinforced, double "O" frame inner structure keeps desk solid and sturdy for years of use.
- All interior drawer bodies are gray, pre-painted steel.
- !** Keyed alike cores ordered separately — see page 746.

HOW TO SPECIFY

Select Model Number	Select Laminate See page 360	Select Paint Color See page 360
H 3 4 9 6 2	N	S

34000 SERIES

Accessories

GSA SIN 33721

ABI

Icon Legend on page 19

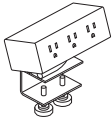

Model HPWRMOD3WC shown

DESCRIPTION**Power Modules**

3 Receptacles with Worksurface Clamp

2 Receptacles 2 USB with Worksurface Clamp

- 6' power cord with standard three-prong plug.
- Under-worksurface mounting bracket models work with any top that has a 5" x 5" square clearance.
- Worksurface clamp models work on any top with a 4" overhang.
- UL Listed.

NOTES: For additional information see the Workplace Tools section in the 2021 Shared Spaces Pricer.

- ! Color finish coordinates with HON's Charcoal or White. Specify *STRM* for Storm or *SNW* for Snow when ordering. Example: HPWRMOD3WC.STRM.

MODEL**SHIP WEIGHT****CUBE****LIST PRICE****HPWRMOD3WC**

2.3 Ⓢ

0.2

\$310**HPWRMOD2WC**

2.3 Ⓢ

0.2

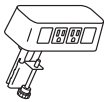
\$496**Power & Data Center**

2 Receptacles 2 Data Accessory

- Standard with two receptacles and openings for two data ports.
- 6' power cord with standard three-prong plug.
- Fits on any worksurface with a 4" overhang.
- UL Listed.

NOTES: For additional information see the Workplace Tools section in the 2021 Shared Spaces Pricer.

- ! Color finish coordinates with HON's Loft. Specify *LOFT* when ordering. Example: HCOMDOME2.LOFT.

HCOMDOME2

2.5 Ⓢ

0.2

\$296**Vertebrae**

NOTES: 30"H x 3 1/8"W x 1 1/2"D. Ships unassembled. For additional information see the Workplace Tools section in the 2021 Shared Spaces Pricer.

- ! Clear finish. Specify "X" for finish option.

SPECIFYING EXAMPLE: HMPVWM28.X**HMPVWM28**

3.0

0.3

\$223**Storage Cube**

12"W x 12"D







SPECIFYING EXAMPLE: HLSL1212.P8S**HLSL1212**

1.0

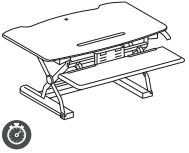
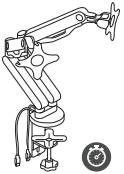
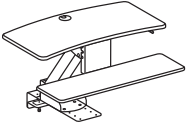
0.3

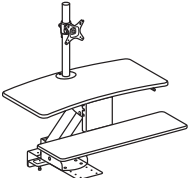
\$294**HOW TO SPECIFY**Select
Model Number

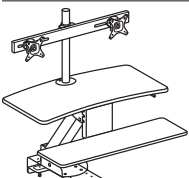
H P W R M O D 3 W C

	DESCRIPTION	MODEL	SHIP WEIGHT	CUBE	LIST PRICE
	Coordinate™ Portable Desktop Riser 31"D x 5"-16½"H x 35"W NOTES: Available in Black (BLK) or White (WHT) finish. Desktop riser dimensions (without keyboard tray): 22"D x 5"-16½"H x 35"W. Keyboard tray dimensions: 9"D x 30"W. Max loading capacity is 33 lbs for the desktop riser surface and 4 lbs for the keyboard tray. Easily transition from seated to standing positions throughout the workday. Sits atop an existing desk to create sit-to-stand functionality by raising the computer. Includes keyboard tray and surface for computer monitors. HON 5-Year Limited Warranty. ! Not intended for use on mobile workstations.	HBXRISER	54.0	4.1	\$619
	Dual Monitor Arm with 2 USB Ports NOTES: Easy adjustment. Height adjusts to 17" tall. Monitor tilt and swivel capability. Enclosed cable management. Grommet or desktop mounting. Clean appearance. In some applications the Monitor Arms may extend 12 or more inches into the worksurface. For additional information see the Workplace Tools section in the 2021 Shared Spaces Pricer. HON 5-Year Limited Warranty. ! No specification needed.	HBDMAUSB	41.9	2.6	\$383
	Coordinate™ Mounted Desktop Riser NOTES: Does not include a monitor arm and is suitable for laptops and/or monitors on their original stands. ! No specification needed.	HS1100	60.0 	3.2	\$664
	Coordinate™ Mounted Desktop Riser with Single Monitor Arm NOTES: Includes a monitor arm for a single monitor. ! No specification needed.	HS1101	62.0 	3.2	\$777
	Coordinate™ Mounted Desktop Riser with Dual Monitor Arm NOTES: Includes a monitor arm for dual monitors. ! No specification needed.	HS1102	63.0 	3.2	\$883

NOTES FOR HS1100, HS1101, HS1102:

- These products are designed to allow the user to transition from seating position to standing position throughout the workday.
- Gas-assist lever-operated mechanism with positive stop.
- Clamp mount compatible with worksurfaces depths of 20"-30". 20" is for systems only.
- Clamp requires 3.5" of clearance along back edge of worksurface.
- Black seamless worksurfaces.
- Silver powder coated metal components.
- Lowers below worksurface level on 24" and 30"D worksurfaces.
- All models contain a large primary worksurface and a smaller keyboard / mouse surface.
- Beveled edges for sleek appearance and comfort while typing.
- Monitor arms include height, width, and swivel adjustment.

- Not for use under overhead storage, with flush mounted modesty panels, or worksurfaces thinner than 1".

! Not recommended for use on mobile (castered) worksurfaces.

MOUNTING AND COMPATIBILITY FOR HS1100, HS1101, HS1102:

- This product is intended to be installed on commercial-grade worksurfaces in good condition.
- Compatible with freestanding worksurfaces 24"-30"D or panel-supported worksurfaces 24"-30"D.
- Not for use on mobile worksurfaces.

Clamp Mount

Use when 3.5" minimum overhang is available

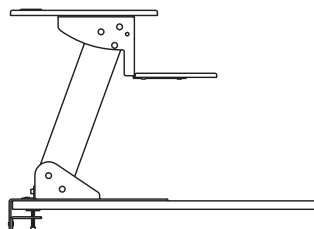

Screw Mount

Use when no overhang is available. Worksurface must be minimum 1" thick.

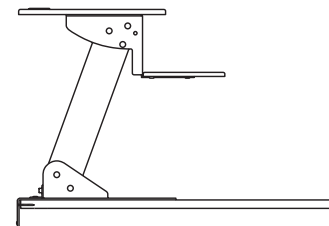

HOW TO SPECIFY

Select Model Number	Select Finish			
	BLK Black WHT White			
HBXRISER.	BLK			



34000 SERIES

Accessories

OPEN MARKET

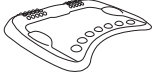
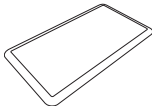
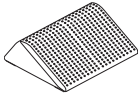

Icon Legend on page 19

	DESCRIPTION	MODEL	SHIP WEIGHT	CUBE	LIST PRICE
	Rectangle Wobble Board — Anti-Fatigue Mat 18"D x 3"H x 22¼"W ⓘ Available in Black (T) finish ONLY. Recommended weight capacity not to exceed 250 pounds. HON 5-Year Limited Warranty. SPECIFYING EXAMPLE: HVL981.T	HVL981 ⓘ	10.0 Ⓢ	0.9	\$121
	Round Wobble Board — Anti-Fatigue Mat 18½"D x 2½"H x 18½"W ⓘ Available in Black (T) finish ONLY. Recommended weight capacity not to exceed 250 pounds. HON 5-Year Limited Warranty. SPECIFYING EXAMPLE: HVL982.T	HVL982 ⓘ	5.8 Ⓢ	0.6	\$103
	Ergonomic Anti-Fatigue Mat 25"D x 2¾"H x 29⅞"W ⓘ Available in Black ONLY. No specification needed. SPECIFYING EXAMPLE: HBEAFM1	HBEAFM1	7.0	1.4	\$219
	Rectangle Anti-Fatigue Mat 20"D x ¾"H x 36"W ⓘ Available in Black ONLY. No specification needed. SPECIFYING EXAMPLE: HBAFM2036	HBAFM2036 ⓘ	5.4	0.4	\$100
	Footrest — Anti-Slip Cover 13¾"D x 5½"H x 16"W ⓘ Available in Black (T) finish ONLY. Recommended weight capacity not to exceed 250 pounds. HON 5-Year Limited Warranty. SPECIFYING EXAMPLE: HVL991.T	HVL991	7.0 Ⓢ	0.9	\$82

NOTES:

ⓘ Discontinued 1/1/21.

HOW TO SPECIFY

Select Model Number H V L 9 8 1 .	Select Finish T Black
---	---------------------------------

38000 SERIES™



38000 Series™ Station shown with Solve® Seating.

38000 SERIES™

The 38000 Series is America's best-selling steel desk — and with good reason. Rugged good looks. Precision engineering. Best-in-class construction. This modular collection blends designer touches like stylish, high-pressure laminate with useful details like cord-management. Which makes the 38000 Series the ideal desk solution for any organization seeking premium performance for a moderate price.



FEATURES

- Our steel construction is best in class — so it stands up to heavy use and frequent relocation.
- Integrated wire management and optional power hub accommodate today's electronic office.
- Pedestals feature Tru-Fit mitered drawer fronts for precision alignment when closed.
- Curved, waterfall-shaped edge profile provides a comfortable typing surface.
- Premium, multi-ply laminate worksurface stands up to scratches, spills and stains, and holds up under heavy use.
- Steel ball-bearing drawer suspensions operate easily and quietly.
- Cord management provides access to wall outlets, and allows cords to run through the or between components.

38000 SERIES™ ORDERING INFORMATION

FINISHES AVAILABILITY

L1 LAMINATES/EDGE BAND

COLOR CODES

Woodgrain

◆ Bourbon Cherry/ Bourbon Cherry	H
◆ Cognac/Cognac	COGN
◆ Florence Walnut/ Florence Walnut	LFW1
◆ Harvest/Harvest	C
◆ Kingswood Walnut/ Kingswood Walnut	LK11
◆ Mahogany/Mahogany	N
◆ Mocha/Mocha	MOCH
◆ Natural Maple/ Natural Maple	D
◆ Pinnacle/Pinnacle	PINC
◆ Shaker Cherry/ Shaker Cherry	F
◆ Sterling Ash/ Sterling Ash	LSA1

Solid

◆ Black/Black	P
◆ Charcoal/Charcoal	S
◆ Designer White/ Designer White	LDW1
◆ Loft/Loft	LOFT

Patterned

◆ Sheer Mesh/Muslin	A5
◆ Silver Mesh/Loft	B9
◆ Steel Mesh/Charcoal	A9
◆ Canyon Zephyr/ Greige	K9
◆ Desert Zephyr/ Greige	K8
◆ Shadow Zephyr/ Loft	K1
◆ Gray/Matches Paint Color	G2
◆ Grey Tigris/Greige	L6
◆ White/Matches Paint Color	G1
◆ Whitestone/Matches Paint Color	K4

FINISHES AVAILABILITY *continued*

PAINTS CODES

P1	
◆ Black	P
◆ Brownstone	P7D
◆ Charcoal	S
◆ Designer White	PJW
◆ Fossil	P28
◆ Greige	T5
◆ Light Gray	Q
◆ Loft	LOFT
◆ Muslin	T3
◆ Putty	L
◆ Shadow *	SHDW
◆ Titanium	P8T
P2	
◆ Champagne Metallic	T4
◆ Platinum Metallic	T1

NOTE: Where 38000 edgeband does not match laminate color, alternative color is on flat edges only (sides, sides and back edge on returns and bridges, flat sides of corner unit, and flat end of peninsulas).

• STEEL DESKS

SPECIFY: Model Number.
Top Laminate
Paint Color

EXAMPLE: H38934.NS

• 38000 TACKBOARDS

(Fabric listed on pages 25-26)

SPECIFY: Model Number
Fabric Style.
Color Code
Paint Color

EXAMPLE: HT72.CE18.P

◆◆◆ For lead time information see page 19.

* De-emphasized

38000 SERIES™

Typicals — 3/4 Height Pedestals



Icon Legend on page 19

Components used are listed on pages 372-380. Order components individually. Other configurations are possible, including various sizes of some components.

QTY	DESCRIPTION	MODEL	LIST PRICE	PRICE EXTENSION
1	Double Pedestal Desk 72"W x 36"D x 29½"H	H38180	\$1,974	\$1,974
1	Credenza with Kneespace 72"W x 24"D x 29½"H	H38854	\$1,714	\$1,714
TOTAL:			\$3,688	

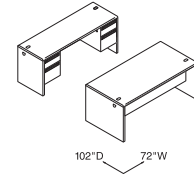

DESK WORKSTATION WITH CREDEZA
72"W x 102"D

QTY	DESCRIPTION	MODEL	LIST PRICE	PRICE EXTENSION
1	Single Pedestal Desk 72"W x 36"D x 29½"H	H38293R	\$1,760	\$1,760
1	Stack-on Storage w/o Doors 72½"W x 13½"D x 34¾"H	H386572N	\$929	\$929
1	Bridge 48"W x 24"D x 37⅞"H	H38210	\$593	\$593
1	Flipper Doors 2@36"W x 15"H	H387215	\$577	\$577
1	Single Pedestal Credenza 72"W x 24"D x 29½"H	H38855L	\$1,461	\$1,461
TOTAL:			\$5,320	

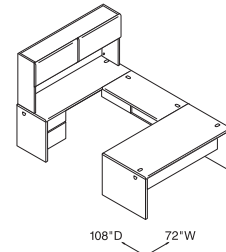

DESK "U" WORKSTATION
72"W x 108"D

QTY	DESCRIPTION	MODEL	LIST PRICE	PRICE EXTENSION
1	Single Pedestal Desk 72"W x 36"D x 29½"H	H38293R	\$1,760	\$1,760
1	Stack-on Storage w/o Doors 72½"W x 13½"D x 34¾"H	H386572N	\$929	\$929
1	Left, Return, box/file 60"W x 24"D x 29½"H	H38218L	\$1,169	\$1,169
1	Flipper Doors 2@36"W x 15"H	H387215	\$577	\$577
TOTAL:			\$4,435	

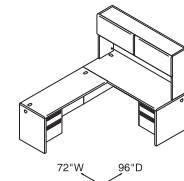

DESK "L" WORKSTATION
72"W x 96"D

QTY	DESCRIPTION	MODEL	LIST PRICE	PRICE EXTENSION
1	Peninsula with Full End Panel 70"W x 36"D x 29½"H	H38941	\$1,375	\$1,375
1	Stack-on Storage w/o Doors 72½"W x 13½"D x 34¾"H	H386572N	\$929	\$929
1	Bridge 42"W x 24"D x 29½"H	H38220	\$564	\$564
1	Flipper Doors 2@36"W x 15"H	H387215	\$577	\$577
1	Single Pedestal Credenza, Left 72"W x 24"D x 29½"H	H38855L	\$1,461	\$1,461
TOTAL:			\$4,906	

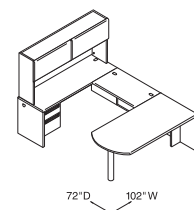

PENINSULA "U" WORKSTATION
72"W x 102"D



Icon Legend on page 19

38000 SERIES™ Typicals — Modular

Components used are listed on pages 372-380. Order components individually. Other configurations are possible, including various sizes of some components.

QTY	DESCRIPTION	MODEL	LIST PRICE	PRICE EXTENSION
1	Shell Desk 72"W x 36"D x 29½"H	H38934	\$1,197	\$1,197
1	Flagship Mobile Pedestal – file/file 15"W x 22⅞"D x 28"H	H18823R	\$743	\$743
1	Return Shell, Left 48"W x 24"D x 29½"H	H38944L	\$834	\$834
1	Standard Height Mobile Pedestal – box/box/file 15"W x 16⅞"D x 28"H	H18717R	\$698	\$698
TOTAL:			\$3,472	

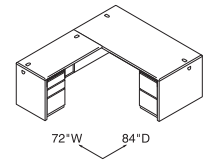

MODULAR DESK WORKSTATION
84"W x 72"D

QTY	DESCRIPTION	MODEL	LIST PRICE	PRICE EXTENSION
1	Shell Desk 72"W x 36"D x 29½"H	H38934	\$1,197	\$1,197
1	Flagship Mobile Pedestal – file/file 15"W x 22⅞"D x 28"H	H18823R	\$743	\$743
1	Bridge 48"W x 24"D x 29½"H	H38210	\$593	\$593
1	Shell Desk 72"W x 24"D x 29½"H	H38925	\$1,158	\$1,158
1	Standard Height Mobile Pedestal – box/box/file 15"W x 16⅞"D x 28"H	H18717R	\$698	\$698
1	Stack-on Storage w/o Doors 72⅝"W x 13½"D x 34¾"H	H386572N	\$929	\$929
TOTAL:			\$5,318	

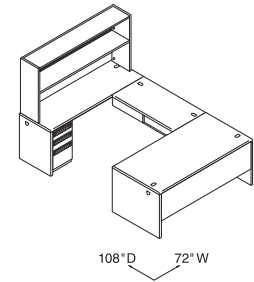

MODULAR DESK "U" WORKSTATION
72"W x 108"D

QTY	DESCRIPTION	MODEL	LIST PRICE	PRICE EXTENSION
1	Corner Unit	H38928	\$1,345	\$1,345
1	Peninsula with End Panel 70"W x 36"D x 29½"H	H38941	\$1,375	\$1,375
1	Bridge 42"W x 24"D x 29½"H	H38220	\$564	\$564
1	Shell Return, Right 72"W x 24"D x 29½"H	H38947R	\$1,111	\$1,111
1	Flagship Lateral File 30"W x 18"D x 28"H	H9170R	\$992	\$992
1	Stack-on Storage w/o Doors 72⅝"W x 13½"D x 34¾"H	H386572N	\$929	\$929
1	Flipper Doors 2@36"W x 15"H	H387215	\$577	\$577
TOTAL:			\$6,893	

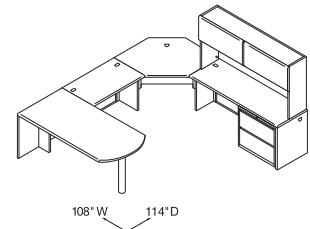

PENINSULA "U" WORKSTATION
108"W x 114"D

QTY	DESCRIPTION	MODEL	LIST PRICE	PRICE EXTENSION
1	Corner Unit	H38928	\$1,345	\$1,345
1	Shell Return, Left 72"W x 24"D x 29½"H	H38948L	\$1,111	\$1,111
1	Standard Height Mobile Pedestal – box/box/file 15"W x 16⅞"D x 28"H	H18717R	\$698	\$698
1	Stack-on Storage w/o Doors 72⅝"W x 13½"D x 34¾"H	H386572N	\$929	\$929
1	Flipper Doors 2@36"W x 15"H	H387215	\$577	\$577
1	Shell Return – Right 72"W x 24"D x 29½"H	H38947R	\$1,111	\$1,111
1	Standard Height Mobile Pedestal – file/file 15"W x 16⅞"D x 28"H	H18817R	\$692	\$692
TOTAL:			\$6,463	

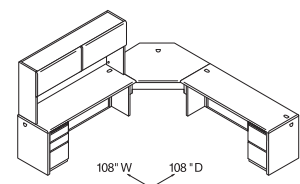

**CORNER UNIT WITH RETURNS
WORKSTATION**
108"W x 108"D

38000 SERIES™ Bundles Typicals



Icon Legend on page 19

Mahogany/Charcoal
H38LL7284NS

Harvest/Putty
H38LL7284CL

QTY	DESCRIPTION	MODEL	LIST PRICE	PRICE EXTENSION
1	Left Pedestal Desk	H38294L	\$1,760	\$1,760
1	Right Return	H38215R	\$1,065	\$1,065
TOTAL:			\$2,825	

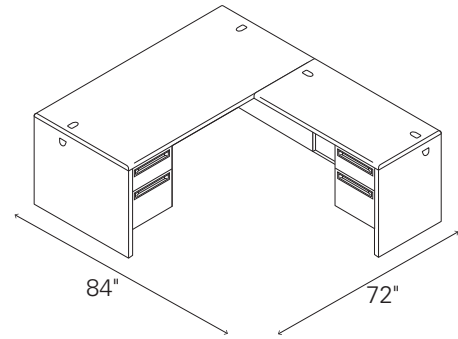

L-STATION (LEFT DESK/RIGHT RETURN)

Mahogany/Charcoal
H38LR7284NS

Harvest/Putty
H38LR7284CL

QTY	DESCRIPTION	MODEL	LIST PRICE	PRICE EXTENSION
1	Right Pedestal Desk	H38293R	\$1,760	\$1,760
1	Left Return	H38216L	\$1,065	\$1,065
TOTAL:			\$2,825	

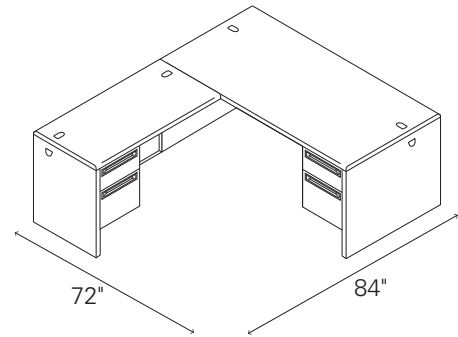

L-STATION (RIGHT DESK/LEFT RETURN)

Mahogany/Charcoal
H38URH72108NS2

Harvest/Putty
H38URH72108CL2

QTY	DESCRIPTION	MODEL	LIST PRICE	PRICE EXTENSION
1	Single Pedestal Desk, Right	H38293R	\$1,760	\$1,760
1	Single Pedestal Credenza, Left	H38855L	\$1,461	\$1,461
1	Hutch without Doors	H386572N	\$929	\$929
1	Flipper Doors, Pair	H387215	\$577	\$577
1	Bridge	H38210	\$593	\$593
TOTAL:			\$5,320	

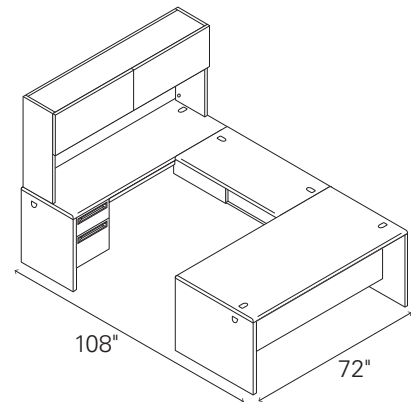

**U-STATION WITH HUTCH
(RIGHT DESK/LEFT CREDENZA)**



Icon Legend on page 19

38000 SERIES™ Bundles Typicals

Mahogany/Charcoal
H38ULH72108NS2

Harvest/Putty
H38ULH72108CL2

QTY	DESCRIPTION	MODEL	LIST PRICE	PRICE EXTENSION
1	Single Pedestal Desk, Left	H38294L	\$1,760	\$1,760
1	Single Pedestal Credenza, Right	H38856R	\$1,461	\$1,461
1	Hutch without Doors	H386572N	\$929	\$929
1	Flipper Doors, Pair	H387215	\$577	\$577
1	Bridge	H38210	\$593	\$593
TOTAL:			\$5,320	

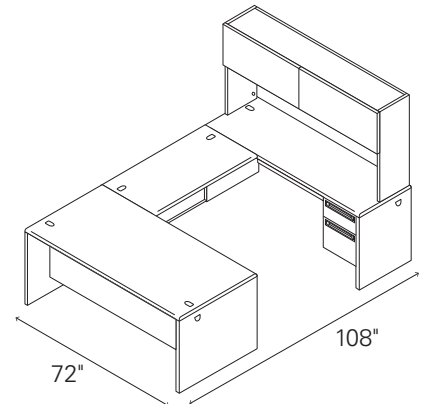

**U-STATION WITH HUTCH
(LEFT DESK/RIGHT CREDEZA)**

Mahogany/Charcoal
H38DCH6096NS2

Harvest/Putty
H38DCH6096CL2

QTY	DESCRIPTION	MODEL	LIST PRICE	PRICE EXTENSION
1	Double Pedestal Desk	H38155	\$1,688	\$1,688
1	Double Pedestal Credenza	H38852	\$1,648	\$1,648
1	Hutch without Doors	H386560N	\$816	\$816
1	Flipper Doors, Pair	H386015	\$543	\$543
TOTAL:			\$4,695	

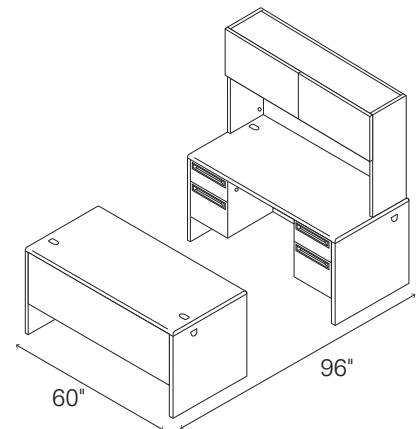

WORKSTATION



38000 SERIES™

Steel Desks — 3/4 Pedestals

GSA SIN 33721

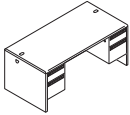
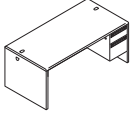

Icon Legend on page 19

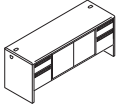
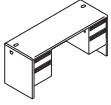
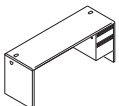
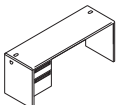
	DESCRIPTION	FULL WIDTH OVERHANG	MODEL	SHIP WEIGHT	CUBE	LIST PRICE BY PAINT GRADE		
						P1	P2	P3
	Double Pedestal — 2/2 w/Locks							
	72"W x 36"D x 29½"H	6"	H38180	256	51.7	\$1974	\$2048	\$2119
	66"W x 30"D x 29½"H		H38170	224	40.1	\$1890	\$1964	\$2035
	60"W x 30"D x 29½"H		H38155	217	36.6	\$1688	\$1762	\$1833
	Single Pedestal w/Lock							
	72"W x 36"D x 29½"H — 2R	6"	H38293R	214	51.7	\$1760	\$1834	\$1905
	66"W x 30"D x 29½"H — 2R		H38291R	181	40.1	\$1621	\$1695	\$1766
	48"W x 30"D x 29½"H — 2R		H38251	155	29.6	\$1435	\$1509	\$1580
	72"W x 36"D x 29½"H — 2L	6"	H38294L	214	51.7	\$1760	\$1834	\$1905
	66"W x 30"D x 29½"H — 2L		H38292L	181	40.1	\$1621	\$1695	\$1766
	48"W x 30"D x 29½"H — 2L		H38252L	155	29.6	\$1435	\$1509	\$1580
	Flush Return — box/file w/Lock							
	60"W x 24"D x 29½"H — 2R		H38217R	138	30.1	\$1169	\$1214	\$1258
	48"W x 24"D x 29½"H — 2R		H38215R	124	24.1	\$1065	\$1110	\$1154
	60"W x 24"D x 29½"H — 2L		H38218L	138	30.1	\$1169	\$1214	\$1258
	48"W x 24"D x 29½"H — 2L		H38216L	124	24.1	\$1065	\$1110	\$1154
	NOTES: Returns have 2 grommets each in worksurface top and full height modesty panel.							
	Credenza w/Doors w/Locks							
72"W x 24"D x 29½"H		H38853	230	35.6	\$1862	\$1936	\$2007	
	NOTES: Pedestals lock.							
	Credenza w/Kneespace w/Locks							
	72"W x 24"D x 29½"H		H38854	172	35.6	\$1714	\$1788	\$1859
	Kneespace: 39¾"W							
	66"W x 24"D x 29½"H		H38851	166	32.7	\$1677	\$1751	\$1822
	Kneespace: 33¾"W							
	60"W x 24"D x 29½"H		H38852	154	29.8	\$1648	\$1722	\$1793
	Kneespace: 27¾"W							
	NOTES: Pedestals lock.							
	Single Pedestal Credenza — 2R w/Lock							
	72"W x 24"D x 29½"H		H38856R	159	35.6	\$1461	\$1535	\$1606
	66"W x 24"D x 29½"H		H38858R	153	32.7	\$1354	\$1428	\$1499
	NOTES: Pedestal locks.							
	Single Pedestal Credenza — 2L w/Lock							
	72"W x 24"D x 29½"H		H38855L	159	35.6	\$1461	\$1535	\$1606
	66"W x 24"D x 29½"H		H38857L	153	32.7	\$1354	\$1428	\$1499
	NOTES: Pedestal locks.							

NOTES:

- 3/4 height modesty panels unless noted.
- Color of pulls and grommets match paint selection for core colors.
- One pencil tray standard per unit except returns.
- Laminate particleboard tops feature attractive, radius edges on front and rear edges of desks. Returns and bridges have radius front and flat rear edge to match the side edge it attaches to.
- Wire grommets standard in all tops.
- Wire grommets in end panels allow cable connections between desks.
- "Tru-fit" mitered drawer fronts for better visual alignment.
- Optional center drawer features steel ball-bearing suspension.
- High-sided file drawers accept hanging files without hangrails.
- Three-part full extension steel ball-bearing suspension on all file drawers for full access to interior contents.
- Box drawers feature two-part, ¾" extension steel ball-bearing suspension.
- Baked enamel finish over rust-inhibiting phosphate pre-treatment.
- See page 374 for 38000 Series™ shared components.
- Optional follower block accessory available to organize drawer storage.

HOW TO SPECIFY

Select Model Number	Select Laminate	Select Paint Color
See page 367	See page 367	See page 367
H 3 8 1 8 0	N	S



Icon Legend on page 19

38000 SERIES™ Modular Desks

DESCRIPTION	INSIDE SHELL DIMENSIONS	FULL WIDTH OVERHANG	MODEL	SHIP WEIGHT	CUBE	LIST PRICE BY PAINT GRADE			
						P1	P2	P3	
Desk Shell									
72"W x 36"D x 29½"H	69½"W x 28¾"D	6"	H38934	134	7.1	\$1197	\$1271	\$1342	
72"W x 30"D x 29½"H	69½"W x 28¾"D		H38935	118	6.0	\$1165	\$1239	\$1310	
66"W x 30"D x 29½"H	63½"W x 28¾"D		H38933	108	6.0	\$1148	\$1222	\$1293	
60"W x 30"D x 29½"H	57½"W x 28¾"D		H38932	103	5.1	\$1092	\$1166	\$1237	
48"W x 30"D x 29½"H	45½"W x 28¾"D		H38931	89	5.1	\$1009	\$1083	\$1154	
72"W x 24"D x 29½"H	69½"W x 22¾"D		H38925	99	5.0	\$1158	\$1232	\$1303	
66"W x 24"D x 29½"H	63½"W x 22¾"D		H38923	95	5.0	\$1109	\$1183	\$1254	
60"W x 24"D x 29½"H	57½"W x 22¾"D		H38922	89	4.2	\$1055	\$1129	\$1200	
48"W x 24"D x 29½"H	45½"W x 22¾"D		H38921	83	4.2	\$987	\$1061	\$1132	
Return Shell									
72"W x 24"D x 29½"H, Right	69⅝"W x 22¾"D (2 grommets)		H38947R	87	6.0	\$1111	\$1156	\$1200	
60"W x 24"D x 29½"H, Right	57⅝"W x 22¾"D (2 grommets)		H38945R	80	5.1	\$996	\$1041	\$1085	
48"W x 24"D x 29½"H, Right	45⅝"W x 22¾"D (2 grommets)		H38943R	71	4.2	\$834	\$879	\$923	
42"W x 24"D x 29½"H, Right	39⅝"W x 22¾"D (2 grommets)		H38949R	65	4.2	\$777	\$822	\$866	
72"W x 24"D x 29½"H, Left	69⅝"W x 22¾"D (2 grommets)		H38948L	87	6.0	\$1111	\$1156	\$1200	
60"W x 24"D x 29½"H, Left	57⅝"W x 22¾"D (2 grommets)		H38946L	80	5.1	\$996	\$1041	\$1085	
48"W x 24"D x 29½"H, Left	45⅝"W x 22¾"D (2 grommets)		H38944L	71	4.2	\$834	\$879	\$923	
42"W x 24"D x 29½"H, Left	39⅝"W x 22¾"D (2 grommets)		H38950L	65	4.2	\$777	\$822	\$866	

NOTES: Modular returns feature full height modesty panels.
 ! Not designed to be used freestanding.

NOTES:

- 38000 Series™ Modular Desks offers designer styling, configuration flexibility and storage versatility.
- Create both individual managerial stations and task-oriented work areas.
- Designed with adaptability for today's electronic office.
- Color of pulls and grommets match paint selection for core colors.
- Wire grommets standard in all tops, except peninsulas.
- Wire grommets in end panels allow cable connections between desks.
- Optional center drawer features steel ball-bearing suspension.
- For components that can be shared with 38000 Series™, see page 374.
- ¾ height modesty panels unless noted.
- Ability to use all HON laterals and pedestals.

Recommended Pedestal Options:

38000 Series™	36" Deep Desk			30" Deep Desk			24" Deep Desk		
Contain®, Flagship® or Brigade® Pedestals	Ability to Attach	Ability to Use Wire Port	Ability to Attach Hutch	Ability to Attach	Ability to Use Wire Port	Ability to Attach Hutch	Ability to Attach	Ability to Use Wire Port	Ability to Attach Hutch
16¾"D Hanging Pedestal	•	•	•	•	•	•	•	•	•
22⅞"D Hanging Pedestal	•	•	•	•	•	•	•	•	•
16¾"D Freestanding or Mobile	•	•	•	•	•	•	•	•	•
22⅞"D Freestanding or Mobile	•	•	•	•	•	•	•	•	•
28⅞"D Freestanding or Mobile	•	•	•	•	•	•	•	•	•

Use of a pedestal spacer or 28"H standard height pedestals will block wire access from the grommet to the kneespace area.

NOTES: Stack-on units can be attached regardless of pedestal configuration.

Personalize Your Storage Needs

With These Possible Solutions:

Use coordinating HON components such as Pedestals shown on page 680 and Lateral Files shown on pages 631-635 and 682-683.

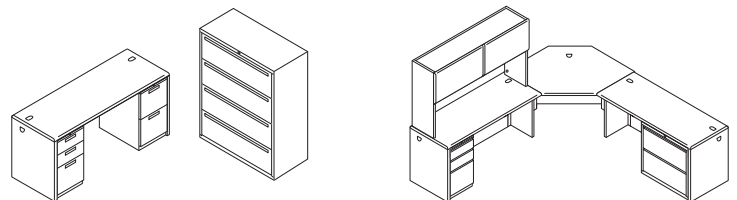

HOW TO SPECIFY

<p>Select Model Number</p> <p>H 3 8 9 3 4 .</p>	<p>Select Laminate</p> <p>See page 367</p> <p>N .</p>	<p>Select Paint Color</p> <p>See page 367</p> <p>S .</p>
--	--	---







38000 SERIES™

Shared Components and Accessories

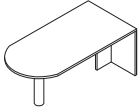
GSA SIN 33721 EXCEPT AS NOTED

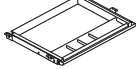

Icon Legend on page 19

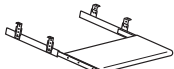
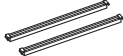
	DESCRIPTION	MODEL	SHIP WEIGHT	CUBE	LIST PRICE BY PAINT GRADE		
					P1	P2	P3
	Peninsula with Support Column and End Panel 70"W x 36"D x 29½"H 70"W x 30"D x 29½"H 66"W x 30"D x 29½"H	H38941 H38942 H38966	136.0 130.0 117.0	15.5 13.2 13.2	\$1375 \$1306 \$1269	\$1420 \$1351 \$1314	\$1464 \$1395 \$1358
	NOTES: Use to create "L" configuration with a Return or "U" configuration with a Bridge and Credenza, Desk or Corner Unit. ! Not designed to be used freestanding.						
	Corner Unit 24" x 36" x 36" x 24" x 29½"H Leading edge is 17"W; leading edge to rear edge is 36"D.	H38928	85.0	7.4	\$1345	\$1419	\$1490
	! Designed to be used with Returns or Bridges.						
	Bridge 48"W x 24"D x 29½"H 42"W x 24"D x 29½"H	H38210 H38220	54.0 Ⓢ 50.0 Ⓢ	4.2 4.2	\$593 \$564	\$611 \$582	\$626 \$597
	NOTES: Full height modesty panel.						
	Metal Center Drawers with core removable locks 24¾"W x 14¾"D for H38180, H38170, H38155 19"W x 14¾"D for H38293R, H38294L, H38291R, H38292L	HD8 HD2	12.0 Ⓢ 9.0 Ⓢ	1.2 1.0	\$263 \$263	\$273 \$273	\$281 \$281
	Refer to the Workplace Tools section in the 2021 Shared Spaces Pricer. NOTES: For additional information see the Workplace Tools section in the 2021 Shared Spaces Pricer. Specify: Paint color.						
	Polymer Center Drawer • Color: Black. • Material: ABS. • Minimum clearance for mounting: 23"W x 16¼"D x 2"H. • Retracts on 16" ball-bearing slides. • Can be used on worksurfaces with Coordinate™ Height Adjustable Bases as long as it is attached with spacer model HKBS. • Can store up to 25 lbs.	HCD1	7.0	0.5	\$111		
	! Black finish only, no specification needed.						
	Corner Sleeve — Square Edge 22½" leading edge x 18"D	H51206	10.0 Ⓢ	1.5	\$161	\$171	\$178
	Refer to the Workplace Tools section in the 2021 Shared Spaces Pricer. NOTES: For additional information see the Workplace Tools section in the 2021 Shared Spaces Pricer. Specify: Paint color.						
	Slide-Away Keyboard Platform (Specify: Laminate) Metal Keyboard and Mouse Tray (Specify paint)	H4022 H4028	10.0 Ⓢ 11.0 Ⓢ	0.6 1.5	\$213 \$153	\$163	
	Refer to the Workplace Tools section in the 2021 Shared Spaces Pricer for additional product information	OPEN MARKET H4029 OPEN MARKET	11.0 Ⓢ	1.5	\$138	\$148	
	NOTES: For additional information see the Workplace Tools section in the 2021 Shared Spaces Pricer.						
	Double-Rail Hanging File Racks — 2 Pack (for side-to-side)	H519495	0.5	0.5	\$34		

NOTES:

- Full end panel legs have neat, contemporary appearance.
- 3/4 height modesty panels unless noted.
- Our broadest selection of components, including components for "U" and "L" workstation arrangements.

- All worksurfaces shown are particleboard.
- Color of grommets match paint selection for core colors.
- 38000 Series™ Stack-on units and accessories listed on pages 374-380.

HOW TO SPECIFY

Select Model Number	Select Laminate	Select Paint Color
See page 367	See page 367	See page 367
H 3 8 9 4 1	N	S



Model HPWRMOD3WC shown

DESCRIPTION**Power Modules**

3 Receptacles with Worksurface Clamp
2 Receptacles 2 USB with Worksurface Clamp

- 6' power cord with standard three-prong plug.
- Under-worksurface mounting bracket models work with any top that has a 5" x 5" square clearance.
- Worksurface clamp models work on any top with a 4" overhang.
- UL Listed.

NOTES: For additional information see the Workplace Tools section in the 2021 Shared Spaces Pricer.

- ! Color finish coordinates with HON's Charcoal or White. Specify *STRM* for Storm or *SNW* for Snow when ordering. Example: *HPWRMOD3WC.STRM*.

MODEL**SHIP WEIGHT****CUBE****LIST PRICE****HPWRMOD3WC**

2.3 Ⓞ

0.2

\$310**HPWRMOD2WC**

2.3 Ⓞ

0.2

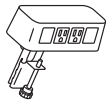
\$496**Power & Data Center**

2 Receptacles 2 Data Accessory

- Standard with two receptacles and openings for two data ports.
- 6' power cord with standard three-prong plug.
- Fits on any worksurface with a 4" overhang.
- UL Listed.

NOTES: For additional information see the Workplace Tools section in the 2021 Shared Spaces Pricer.

- ! Color finish coordinates with HON's Loft. Specify *LOFT* when ordering. Example: *HCOMDOME2.LOFT*.

HCOMDOME2

2.5 Ⓞ

0.2

\$296**Vertebrae**

NOTES: 30"H x 3 1/8"W x 1 1/2"D. Ships unassembled. For additional information see the Workplace Tools section in the 2021 Shared Spaces Pricer.

- ! Clear finish. Specify "X" for finish option.

SPECIFYING EXAMPLE: HMPVWM28.X**HMPVWM28**

3.0

0.3

\$223**Storage Cube**

12"W x 12"D

SPECIFYING EXAMPLE: HLSL1212.P8S**HLSL1212**

1.0

0.3

\$294**HOW TO SPECIFY**

Select
Model Number

H P W R M O D 3 W C

38000 SERIES™

Accessories

OPEN MARKET

Icon Legend on page 19

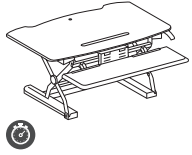
**DESCRIPTION**

Coordinate™ Portable Desktop Riser
31"D x 5"-16½"H x 35"W

MODEL**HBXRISER****SHIP WEIGHT**

54.0

CUBE

4.1

LIST PRICE**\$619**

NOTES: Available in Black (BLK) or White (WHT) finish. Desktop riser dimensions (without keyboard tray): 22"D x 5"-16½"H x 35"W. Keyboard tray dimensions: 9"D x 30"W. Max loading capacity is 33 lbs for the desktop riser surface and 4 lbs for the keyboard tray. Easily transition from seated to standing positions throughout the workday. Sits atop an existing desk to create sit-to-stand functionality by raising the computer. Includes keyboard tray and surface for computer monitors. **HON 5-Year Limited Warranty.**

⚠ Not intended for use on mobile workstations.

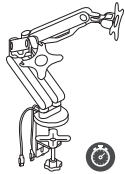

Dual Monitor Arm with 2 USB Ports

HBDMAUSB

41.9

2.6

\$383

NOTES: Easy adjustment. Height adjusts to 17" tall. Monitor tilt and swivel capability. Enclosed cable management. Grommet or desktop mounting. Clean appearance. In some applications the Monitor Arms may extend 12 or more inches into the worksurface. For additional information see the Workplace Tools section in the 2021 Shared Spaces Pricer. **HON 5-Year Limited Warranty.**

⚠ No specification needed.

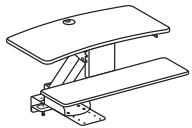

Coordinate™ Mounted Desktop Riser

HS1100

60.0 Ⓢ

3.2

\$664

NOTES: Does not include a monitor arm and is suitable for laptops and/or monitors on their original stands.

⚠ No specification needed.

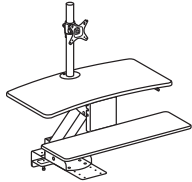

Coordinate™ Mounted Desktop Riser with Single Monitor Arm

HS1101

62.0 Ⓢ

3.2

\$779

NOTES: Includes a monitor arm for a single monitor.

⚠ No specification needed.

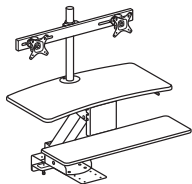

Coordinate™ Mounted Desktop Riser with Dual Monitor Arm

HS1102

63.0 Ⓢ

3.2

\$883

NOTES: Includes a monitor arm for dual monitors.

⚠ No specification needed.

NOTES FOR HS1100, HS1101, HS1102:

- These products are designed to allow the user to transition from seating position to standing position throughout the workday.
- Gas-assist lever-operated mechanism with positive stop.
- Clamp mount compatible with worksurfaces depths of 20"-30". 20" is for systems only.
- Clamp requires 3.5" of clearance along back edge of worksurface.
- Black seamless worksurfaces.
- Silver powder coated metal components.
- Lowers below worksurface level on 24" and 30"D worksurfaces.
- All models contain a large primary worksurface and a smaller keyboard / mouse surface.
- Beveled edges for sleek appearance and comfort while typing.
- Monitor arms include height, width, and swivel adjustment.

- Not for use under overhead storage, with flush mounted modesty panels, or worksurfaces thinner than 1".

⚠ Not recommended for use on mobile (castered) worksurfaces.

MOUNTING AND COMPATIBILITY FOR HS1100, HS1101, HS1102:

- This product is intended to be installed on commercial-grade worksurfaces in good condition.
- Compatible with freestanding worksurfaces 24"-30"D or panel-supported worksurfaces 24"-30"D.
- Not for use on mobile worksurfaces.

Clamp Mount

Use when 3.5" minimum overhang is available

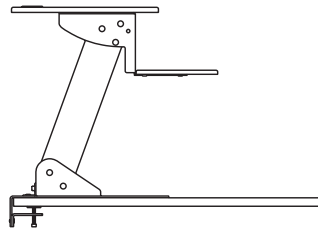
**Screw Mount**

Use when no overhang is available. Worksurface must be minimum 1" thick.

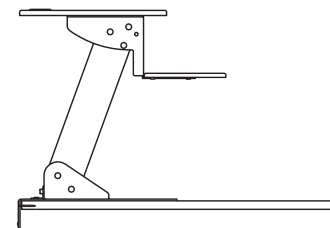
**HOW TO SPECIFY**

Select
Model Number



HBXRISER.

Select
Finish

BLK Black
WHT White

BLK

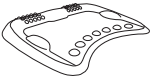
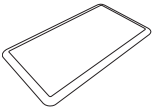
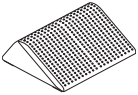

	DESCRIPTION	MODEL	SHIP WEIGHT	CUBE	LIST PRICE
	Rectangle Wobble Board — Anti-Fatigue Mat 18"D x 3"H x 22½"W ⓘ Available in Black (T) finish ONLY. Recommended weight capacity not to exceed 250 pounds. HON 5-Year Limited Warranty. SPECIFYING EXAMPLE: HVL981.T	HVL981 Ⓢ	10.0 Ⓢ	0.9	\$121
	Round Wobble Board — Anti-Fatigue Mat 18½"D x 2⅝"H x 18½"W ⓘ Available in Black (T) finish ONLY. Recommended weight capacity not to exceed 250 pounds. HON 5-Year Limited Warranty. SPECIFYING EXAMPLE: HVL982.T	HVL982 Ⓢ	5.8 Ⓢ	0.6	\$103
	Ergonomic Anti-Fatigue Mat 25"D x 2¾"H x 29⅞"W ⓘ Available in Black ONLY. No specification needed. SPECIFYING EXAMPLE: HBEAFM1	HBEAFM1	7.0	1.4	\$219
	Rectangle Anti-Fatigue Mat 20"D x ¾"H x 36"W ⓘ Available in Black ONLY. No specification needed. SPECIFYING EXAMPLE: HBAFM2036	HBAFM2036 Ⓢ	5.4	0.4	\$100
	Footrest — Anti-Slip Cover 13¾"D x 5½"H x 16"W ⓘ Available in Black (T) finish ONLY. Recommended weight capacity not to exceed 250 pounds. HON 5-Year Limited Warranty. SPECIFYING EXAMPLE: HVL991.T	HVL991	7.0 Ⓢ	0.9	\$82

NOTES:

Ⓢ Discontinued 1/1/21.

HOW TO SPECIFY

<p>Select Model Number</p> <p>H V L 9 8 1 . T</p>	<p>Select Finish</p> <p>T Black</p>
---	-------------------------------------

38000 SERIES™ Steel Stack-on Units

GSA SIN 33721



Icon Legend on page 19

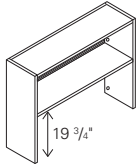

DESCRIPTION

Stack-on Full Clearance without Doors

- 72"W x 13½"D x 34¾"H
- 66"W x 13½"D x 34¾"H
- 60"W x 13½"D x 34¾"H
- 48"W x 13½"D x 34¾"H

NOTES: Interior is 12¾"H.
Specify: Paint color.

MODEL	SHIP WEIGHT	CUBE	LIST PRICE BY PAINT GRADE		
			P1	P2	P3
H386572N	72	6.8	\$929	\$980	\$1029
H386566N	68	6.3	\$881	\$932	\$981
H386560N	64	5.7	\$816	\$867	\$916
H386548N	53	4.7	\$745	\$796	\$845

HOW TO SPECIFY

<p>Select Model Number</p> <p>H 3 8 6 5 7 2 N .</p>	<p>Select Paint Color</p> <p>See page 367</p> <p>P</p>
--	---

DESCRIPTION

Front Flipper Doors

- 2 @ 36"W x 15"H, Flipper Doors for 72"W Stack-on
- 2 @ 33"W x 15"H, Flipper Doors for 66"W Stack-on
- 2 @ 30"W x 15"H, Flipper Doors for 60"W Stack-on
- 1 @ 48"W x 15"H, Flipper Door for 48"W Stack-on

Specify: Paint color.

MODEL	SHIP WEIGHT	CUBE	LIST PRICE BY PAINT GRADE		
			P1	P2	P3
H387215	19	0.9	\$577	\$595	\$621
H386615	17	0.9	\$565	\$583	\$609
H386015	16	0.9	\$543	\$561	\$587
H384815	12	0.5	\$330	\$348	\$374

NOTES:

- Flipper doors are standard with a core removable lock located on the underside of stack-on shelf.
- Many Stack-on sizes available, from 48" to 72" wide.
- Equipped with HON "One Key" interchangeable core removable locks.
- Stack-on units attach to worksurface with double stick tape or with screws provided.
- Stack-ons also compatible with Abode™, Mentor®, Metro Classic, and 66000 Series Computer Furniture.
- Cabinet/door combination kits available for field installation.
- Two dividers standard with every stack-on.
- Color of grommets match paint selection for core colors.

ⓘ Keyed alike cores must be ordered separately — see page 746.

ⓘ Stack-on Units not designed to be used on Corner Units.

HOW TO SPECIFY

<p>Select Model Number</p> <p>H 3 8 7 2 1 5 .</p>	<p>Select Lock Option</p> <p>L Lock X Omit Lock (deduct \$20) See page 746 for omit lock ordering instructions</p> <p>L</p>	<p>Select Paint Color</p> <p>See page 367</p> <p>P</p>
--	--	---



Icon Legend on page 19

38000 SERIES™ Steel Stack-on Units



DESCRIPTION	MODEL	SHIP WEIGHT	CUBE	LIST PRICE BY PAINT GRADE		
				P1	P2	P3
Shelf Dividers — package of 6 Specify: Paint color. Shelf dividers can only be used on stack-ons manufactured after 7/3/2000.	H38SHFDV	3	0.2	\$149	\$160	\$168

HOW TO SPECIFY

<p>Select Model Number</p> <p>H 3 8 S H F D V .</p>	<p>Select Paint Color</p> <p>See page 367</p> <p>P</p>
--	---

38000 SERIES™

Steel Stack-on Units

GSA SIN AS NOTED



Icon Legend on page 19

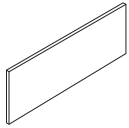

SIN 33721

DESCRIPTION**Tackboard for Stack-on — 19³/₈"H**

72"W
66"W
60"W
48"W

MODEL

HT72ND
HT66ND
HT60ND
HT48ND

SHIP WEIGHT

26.0
24.0
22.0
18.0

CUBE

2.3
2.1
1.9
1.5

LIST PRICE

\$522
\$502
\$486
\$434

Specify: Model.Fabric.Paint. Upcharges may apply to premium fabric grades.

! Disperse (DISP) fabric not available on sizes wider than 60".

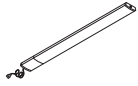

OPEN MARKET

LED Task Lights

17" LED Light with Power Supply (Single)
31" LED Light with Power Supply (Single)

HLED17AS ☉
HLED31AS ☉

1.2 ☉
1.5 ☉

0.05
0.09

\$420
\$564

17" LED Light with Power Supply for Daisy-chain (Starter)
31" LED Light with Power Supply for Daisy-chain (Starter)

HLED17A
HLED31A

1.0 ☉
1.4 ☉

0.05
0.09

\$461
\$619

17" LED Light with 8" Jumper Cord for Daisy-chain (Follower)
31" LED Light with 8" Jumper Cord for Daisy-chain (Follower)

HLED17AUO ☉
HLED31AUO ☉

1.0 ☉
1.0 ☉

0.03
0.05

\$377
\$503

Undercabinet Occupancy Sensor with 1" End to End Connector**HLEDOSA** ☉

0.2 ☉

0.01

\$89

NOTES: To use the daisy chain application, must start with model HLED17A or HLED31A. No finish specification required. Attaches magnetically to underside of overhead storage, or attaches with provided screws or double-sided tape. Occupancy sensor attaches to a single or starter LED light and will automatically turn the light off after no motion is detected for 30 minutes. Just like all the LED light models, the occupancy sensor features a soft-touch on/off switch. LED task lights have a lifetime of 50,000 hours and have a dimmer feature that allows the user to adjust the amount of light output.

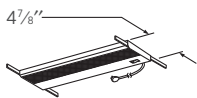

Refer to the Workplace Tools section in the 2021 Shared Spaces Pricer

OPEN MARKET

Recessed Task Light for use under 72", 66" and 60"W Stack-on or Open Shelf46¹/₂"W x 3¹/₁₆"D x 1¹/₈"H**HH870960**

12.0 ☉

1.1

\$270

NOTES: For additional information see the Workplace Tools section in the 2021 Shared Spaces Pricer.

Recessed Task Light for use under 48"W Stack-on or Open Shelf34⁵/₈"W x 3¹/₁₆"D x 1¹/₈"H**HH870942**

10.0 ☉

0.9

\$250

NOTES: For additional information see the Workplace Tools section in the 2021 Shared Spaces Pricer.



SIN 33721

Articulating Desk Lamp**HLED1**

1.2 ☉

6.5

\$402**Articulating Desk Lamp w/ Occupancy Sensor****HLED1OC**

1.2 ☉

6.5

\$490

NOTES: For additional information see the Workplace Tools section in the 2021 Shared Spaces Pricer.



SIN 33721

Task Desk Lamp**HLED2**

0.7 ☉

3.0

\$348

NOTES: For additional information see the Workplace Tools section in the 2021 Shared Spaces Pricer.

NOTES:

- See specifying information above for Choice/Metallic paint and pages 16 and 367 for Custom Paint ordering instructions.
- Tackboards feature painted steel backs and can be installed in the field.

HOW TO SPECIFY

Select Model Number

HT72ND.

Select Fabric Color

See pages 25-26

APN15.

Select Paint Color

See page 367

P

ABODE™



Abode™ shown with Contain® Storage and Endorse® Seating.

ABODE™

The Abode systems desk gives you a consistent look throughout your space and can help you respond easily to future layout changes. It integrates seamlessly with Abound and Accelerate, and can be configured to create freestanding or height adjustable workstations. For greater flexibility and durability in the workspace, look no further than Abode.



FEATURES

- Create a freestanding metal desk that accommodates storage above and below the worksurface.
- Full compatibility with Abound and Accelerate workstations elevates the functionality of Abode.
- Incorporating Coordinate™ makes it easy for workers to adjust their desk height throughout the day, keeping them active, healthy and focused.

ABODE™ ORDERING INFORMATION

WORKSURFACES, COUNTERTOPS, CORNER SHELVES W/EDGEBAND

L1 LAMINATES CODES

Woodgrain

- ◆ Bourbon Cherry H
- ◆ Cognac COGN
- ◆ Florence Walnut LFW1
- ◆ Harvest C
- ◆ Kingswood Walnut LK11
- ◆ Mahogany N
- ◆ Mocha MOCH
- ◆ Natural Maple D
- ◆ Pinnacle PINC
- ◆ Shaker Cherry F
- ◆ Sterling Ash LSA1

Solid

- ◆ Black P
- ◆ Charcoal S
- ◆ Designer White LDW1
- ◆ Loft LOFT

Patterned

- ◆ Sheer Mesh A5
- ◆ Silver Mesh B9
- ◆ Steel Mesh A9
- ◆ Canyon Zephyr K9
- ◆ Desert Zephyr K8
- ◆ Shadow Zephyr K1
- ◆ Gray G2
- ◆ Grey Tigris L6
- ◆ White G1
- ◆ Whitestone K4

L2 LAMINATES CODES

Woodgrain

- ◆ Lowell Ash LLA1
- ◆ Natural Recon LNR1
- ◆ Phantom Ecru LPE1
- ◆ Portico Teak LPT1
- ◆ Skyline Walnut LSW1

(Door panels not available in L2)

WORKSURFACE EDGE BAND

- ◆ Black P
- ◆ Bourbon Cherry H
- ◆ Charcoal S
- ◆ Cognac COGN
- ◆ Designer White DW
- ◆ Florence Walnut FW
- ◆ Greige R
- ◆ Harvest C
- ◆ Kingswood Walnut KI
- ◆ Light Gray Q
- ◆ Loft LOFT
- ◆ Lowell Ash DL
- ◆ Natural Maple N
- ◆ Mocha MOCH
- ◆ Muslin T
- ◆ Natural Maple D
- ◆ Natural Recon NR
- ◆ Phantom Ecru PE
- ◆ Pinnacle PINC
- ◆ Platinum K
- ◆ Portico Teak DP
- ◆ Shadow* SHDW
- ◆ Shaker Cherry F
- ◆ Skyline Walnut SW
- ◆ Sterling Ash SA

WORKSURFACE GROMMET

- ◆ Black P
- ◆ Brownstone EY
- ◆ Charcoal S
- ◆ Fossil EH
- ◆ Greige T5
- ◆ Light Gray Q
- ◆ Loft LOFT
- ◆ Muslin T3
- ◆ Shadow* SHDW
- ◆ Titanium T1
- ◆ Designer White DW
- ◆ Champagne Metallic T4
- ◆ Platinum Metallic T1

FRAMES, TRIM, METAL TILES, CUSTOM BRACKET KIT, WORKSURFACE SUPPORTS, STEEL OVERHEAD STORAGE CHASSIS

PAINT CODES

P1

- ◆ Black P
- ◆ Brownstone P7D
- ◆ Charcoal S
- ◆ Designer White PJW
- ◆ Fossil P28
- ◆ Greige T5
- ◆ Light Gray Q
- ◆ Loft LOFT
- ◆ Muslin T3
- ◆ Putty L
- ◆ Shadow* SHDW
- ◆ Titanium P8T

P2

- ◆ Champagne Metallic T4
- ◆ Platinum Metallic T1
- ◆ Silver PR6

DUPLEX/PORTED TILE

PLASTIC CODES

- ◆ Black P
- ◆ Charcoal S
- ◆ Designer White DW
- ◆ Loft LOFT
- ◆ Muslin T3
- ◆ Titanium T1

Recommendations

Paint	Duplex-Data Code
Black P	Black P
Brownstone P7D	Brownstone EY
Charcoal S	Charcoal S
Designer White PJW	Designer White DW
Fossil P28	Charcoal S
Greige T5	Muslin T3
Light Gray Q	Loft LOFT
Loft LOFT	Loft LOFT
Muslin T3	Muslin T3
Putty L	Black P
Shadow SHDW	Muslin T3
Silver PR6	Titanium T1
Titanium P8T	Titanium T1
Champagne Metallic T4	Muslin T3
Platinum Metallic T1	Titanium T1

► LAMINATE TOPS

SPECIFY: Model Number.

Laminate

Edge Color

Grommet Color

EXAMPLE: HWR2424P.K&R.T5

► PAINTED PRODUCTS

SPECIFY: Model Number.

Paint Color

EXAMPLE: HRVSHV24.T1

◆◆◆ For lead time information see page 19.

* De-emphasized

Edge Treatments

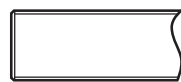

"P" Edgeband

(Color must be selected.)

WORKING WITH ABODE™ COMPONENTS

Configurations

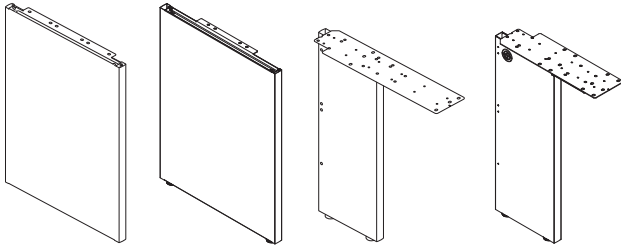

End Panels and Support Legs

Each are available in two options: freestanding or panel mount. The only difference between the two options are the panel-mount models come with a left- or right-handed bracket to attach the support to a panel in a systems application.

The 11"D end panel is used to support peninsulas.

Corner Desk Legs

Corner desk legs have a 90-degree bend and welded construction. The strong construction allows gussets or half-height modesty panels to be used with corner legs.

Bridge Kits

Bridge kits include: two flat brackets, two modesty panel-to-end panel attachment brackets, and two tie straps. This kit is used when attaching a bridge unit between two rectangular worksurfaces.

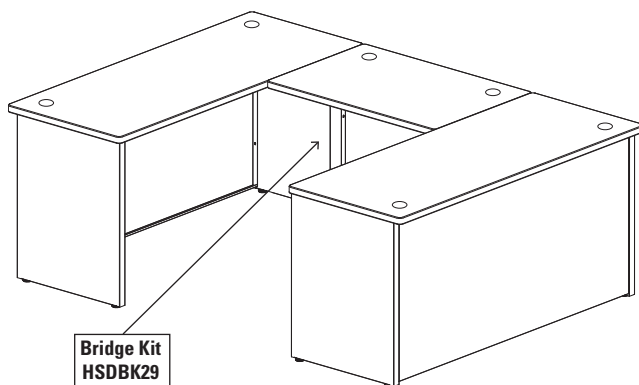

There are some bridge instances where only half of a bridge kit is needed (e.g., using a bridge between a rectangular worksurface and a corner or peninsula). A return kit may be ordered for these instances.

Support Column

Support columns are used to support one end of curvilinear worksurfaces. Includes column, worksurface bracket kit HWSA2, attaching hardware, and adjustable glides.

Return Kits

Return kits include: one flat bracket, one modesty panel-to-end panel attachment bracket, and one tie strap. These are used when attaching a return to a primary desk. Return kits can also be used in some bridge applications — one example is shown below when using a peninsula.

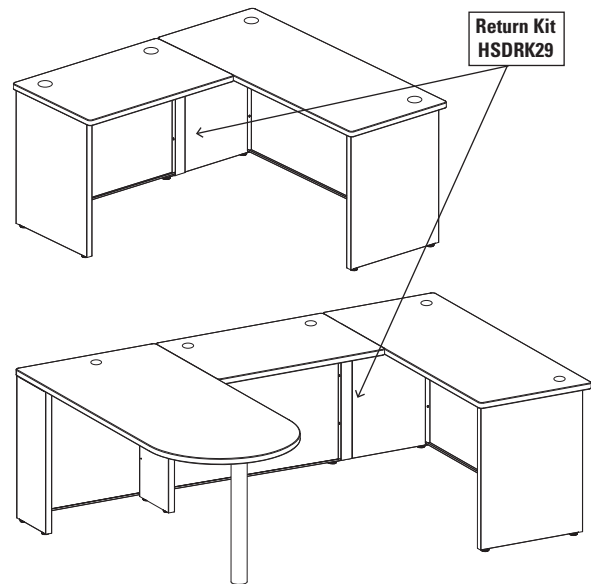

Desk-to-Panel Attachment Kits

Desk-to-panel attachment kits are used to connect a worksurface and modesty panel perpendicular to a panel of corresponding width. Opposing end of worksurface must be attached with an end panel, support leg, or corner leg mounted directly under this worksurface.

When using a corner or corner cove worksurface with the rear corner attached to a panel, and opposing end of worksurface is attached to a freestanding desk, use corner w/desk attachment kit. Hand of unit is determined from the user's side of the desk (right-hand unit attaches to right side of modesty).

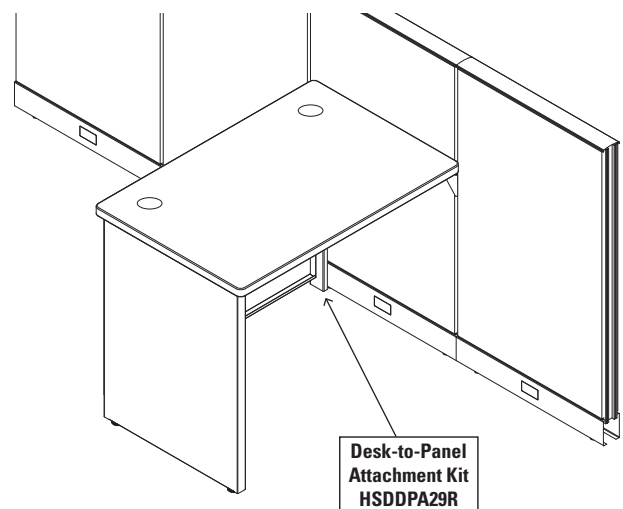

Corner w/Desk Panel Attachment Kit

Corner w/desk panel attachment kit connects the rear corner of a corner or corner cove worksurface and modesty panel to a panel when the opposing end of the worksurface shares a support leg with an adjacent freestanding desk and the support leg is mounted under the freestanding desk. Hand of unit is determined from the user's side of the desk (left-hand unit attaches to left side of modesty).

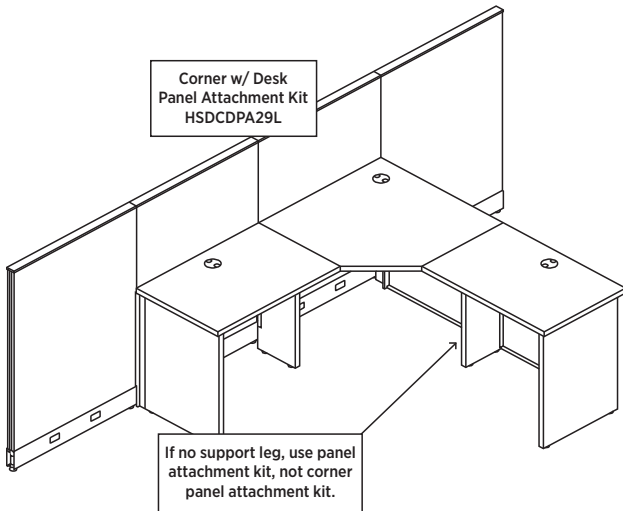

Corner Worksurfaces

Corner worksurfaces accommodate 90-degree corner desk legs.

In-Line Connections of Desks

Shared leg can be used at in-line connections to support adjacent rectangular desks.

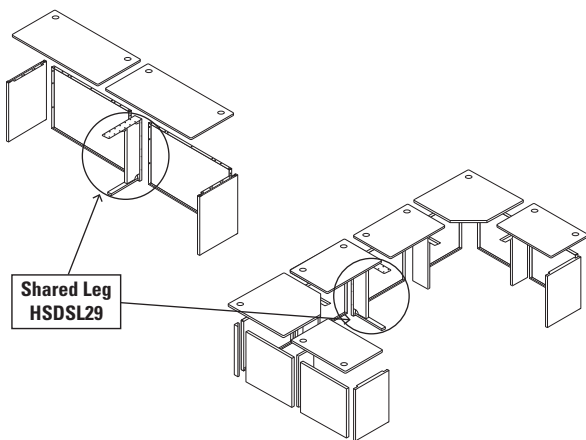

Pedestals and Storage

Pedestals must be ordered smaller than the depth of the worksurface. For example, 18" D peds should be used with 24" D worksurfaces. 18" D or 23" D pedestals can be used with 30" D worksurfaces. Using 18" D laterals or personal files provide additional storage options under 24" D worksurfaces.

Modesty Panels

The following are some general guidelines for Abode™ modesty panels:

- **Desk:** Modesty panel width is the same width as the worksurface
- **Return:** Modesty panel width is 6" greater than the width of the worksurface
- **Bridge connecting two rectangular worksurfaces:** Modesty panel width is 12" greater than the width of the bridge worksurface
- **Bridge connecting a rectangular worksurface and corner or peninsula:** Modesty panel width is 6" greater than the width of the worksurface
- **Corner connecting to an adjacent worksurface:** Modesty panel width is the same width as the worksurface.

Stand-Alone Corner Modesty Panels

Stand-alone corner modesty panels are used only when one or both sides of a corner or corner cove worksurface are freestanding and NOT attached to another worksurface. Specify the width the same as the width of the worksurface.

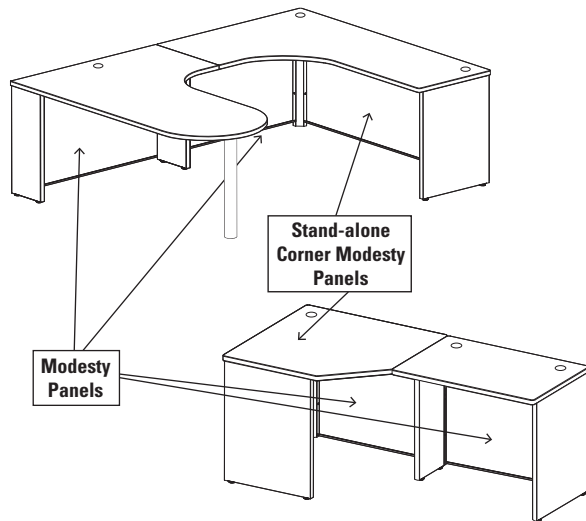

Gussets "G"

Gussets can be used in place of a modesty panel with desks 36" W to 60" W. Gussets can also be used with corner desk legs.

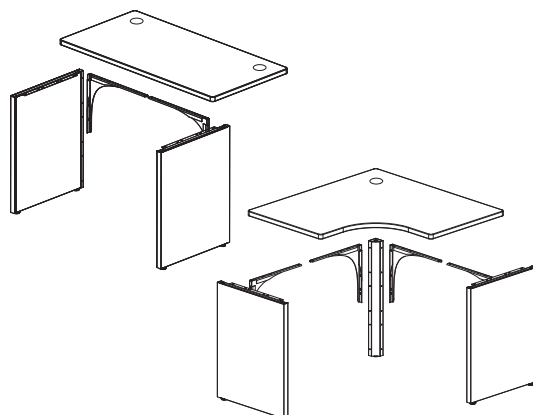



Icon Legend on page 19

The following five pages contain examples of Abode™ workstations. Each “typical” is shown in 3D hidden line perspective. Along with each typical is a complete listing of all the components. Use the information and format to better understand the layout and specifying of Abode™.

QTY	DESCRIPTION	MODEL	LIST PRICE	PRICE EXTENSION
1	Rectangle Worksurface 24”D x 36”W	HWR2436P	\$346	\$346
2	Freestanding End Panel Support 24”D x 29½”H	HSDEP2429F	\$198	\$396
1	Full-Height Modesty Panel 36”W x 29½”H	HSDMP369	\$187	\$187
TOTAL:				\$929

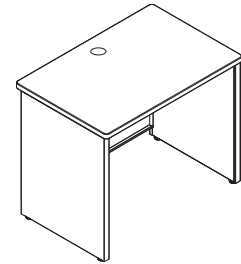

FREESTANDING DESK

QTY	DESCRIPTION	MODEL	LIST PRICE	PRICE EXTENSION
1	Rectangle Worksurface 24”D x 36”W	HWR2436P	\$346	\$346
1	Freestanding End Panel Support 24”D x 29½”H	HSDEP2429F	\$198	\$198
1	Full-Height Modesty Panel 36”W x 29½”H	HSDMP369	\$187	\$187
1	Desk-to-Panel Attachment Kit – Right-Handed 29½”H	HSDPA29R	\$100	\$100
TOTAL:				\$831

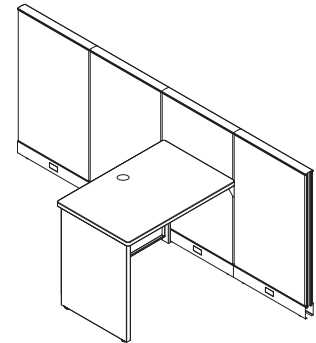

PANEL-ATTACHED DESK

QTY	DESCRIPTION	MODEL	LIST PRICE	PRICE EXTENSION
1	Rectangle Worksurface 24”D x 36”W	HWR2436P	\$346	\$346
1	Rectangle Worksurface 24”D x 60”W	HWR2460P	\$477	\$477
1	Full-Height Modesty Panel 42”W x 29½”H	HSDMP429	\$191	\$191
3	Freestanding End Panel Support 24”D x 29½”H	HSDEP2429F	\$198	\$594
1	Return Kit 29½”H	HSDRK29	\$103	\$103
1	Full-Height Modesty Panel 60”W x 29½”H	HSDMP609	\$203	\$203
TOTAL:				\$1,914

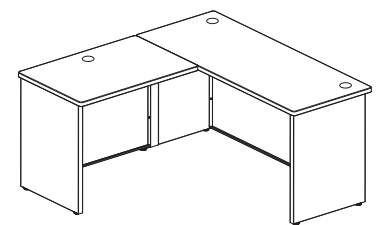

RETURN DESK

Attached to a primary or return desk

QTY	DESCRIPTION	MODEL	LIST PRICE	PRICE EXTENSION
1	Rectangle Worksurface 24”D x 48”W	HWR2448P	\$404	\$404
1	Full-Height Modesty Panel 54”W x 29½”H	HSDMP549	\$201	\$201
1	Freestanding End Panel Support 24”D x 29½”H	HSDEP2429F	\$198	\$198
1	Return Kit 29½”H	HSDRK29	\$103	\$103
1	End Panel Support – Right 24”D x 29½”H	HRVEP2429R	\$223	\$223
1	End Panel Support – Left 24”D x 29½”H	HRVEP2429L	\$223	\$223
1	Rectangle Worksurface 24”D x 60”W	HWR2460P	\$477	\$477
TOTAL:				\$1,829

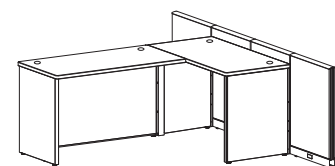

RETURN DESK

Attached to a panel-hung worksurface



QTY	DESCRIPTION	MODEL	LIST PRICE	PRICE EXTENSION
1	Rectangle Worksurface 24"D x 42"W	HWR2442P	\$380	\$380
2	Rectangle Worksurface 24"D x 72"W	HWR2472P	\$529	\$1,058
1	Full-Height Modesty Panel 54"W x 29½"H	HSDMP549	\$201	\$201
1	Bridge Kit	HSDBK29	\$197	\$197
2	Full-Height Modesty Panel 72"W x 29½"H	HSDMP729	\$211	\$422
4	Freestanding End Panel Support 24"D x 29½"H	HSDEP2429F	\$198	\$792
TOTAL:				\$3,050

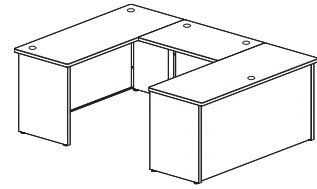

BRIDGE DESK

Attached between two primary desks

QTY	DESCRIPTION	MODEL	LIST PRICE	PRICE EXTENSION
1	Rectangle Worksurface 24"D x 36"W	HWR2436P	\$346	\$346
1	Rectangle Worksurface 24"D x 60"W	HWR2460P	\$477	\$477
1	Peninsula Worksurface 30"D x 60"W	HWP3060P	\$629	\$629
1	Full-Height Modesty Panel 42"W x 29½"H	HSDMP429	\$191	\$191
1	Full-Height Modesty Panel 30"W x 29½"H	HSDMP309	\$185	\$185
2	Freestanding End Panel Support 24"D x 29½"H	HSDEP2429F	\$198	\$396
1	Full-Height Modesty Panel 60"W x 29½"H	HSDMP609	\$203	\$203
1	Freestanding End Panel Support 11"D x 29½"H	HSDEP1129F	\$187	\$187
1	Freestanding Support Leg 24"D x 29½"H	HSDSL2429F	\$208	\$208
1	Support Column for Peninsula	HCNLEG29	\$217	\$217
1	Return Kit 29½"H	HSDRK29	\$103	\$103
TOTAL:				\$3,142

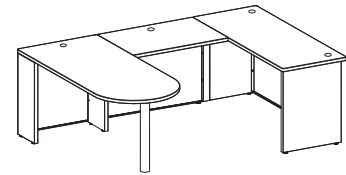

BRIDGE DESK AND PENINSULA

Attached to a primary desk

QTY	DESCRIPTION	MODEL	LIST PRICE	PRICE EXTENSION
1	Corner Worksurface 24"D x 36"W	HWCS3624P	\$522	\$522
2	Stand-Alone Corner Modesty Panel 36"W x 29½"H	HSDCMP3629	\$187	\$374
2	Freestanding End Panel Support 24"D x 29½"H	HSDEP2429F	\$198	\$396
1	Corner Desk Leg 29½"H	HSDDL29	\$168	\$168
TOTAL:				\$1,460

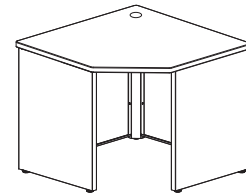

CORNER DESK

Stand-alone

QTY	DESCRIPTION	MODEL	LIST PRICE	PRICE EXTENSION
1	Corner Worksurface 24"D x 36"W	HWCS3624P	\$522	\$522
1	Rectangle Worksurface 24"D x 36"W	HWR2436P	\$346	\$346
1	Stand-Alone Corner Modesty Panel 36"W x 29½"H	HSDCMP3629	\$187	\$187
2	Full-Height Modesty Panel 36"W x 29½"H	HSDMP369	\$187	\$374
2	Freestanding End Panel Support 24"D x 29½"H	HSDEP2429F	\$198	\$396
1	Freestanding Support Leg 24"D x 29½"H	HSDSL2429F	\$208	\$208
1	Corner Desk Leg 29½"H	HSDDL29	\$168	\$168
TOTAL:				\$2,201

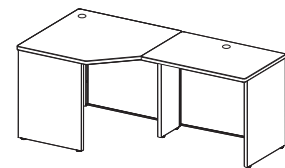

CORNER DESK

With adjacent desk attached at one side



Icon Legend on page 19

ABODE™ Typicals

QTY	DESCRIPTION	MODEL	LIST PRICE	PRICE EXTENSION
2	Rectangle Worksurface 24"D x 36"W	HWR2436P	\$346	\$692
1	Rectangle Worksurface 24"D x 72"W	HWR2472P	\$529	\$529
1	Corner Worksurface 24"D x 36"W	HWCS3624P	\$522	\$522
1	Full-Height Modesty Panel 42"W x 29½"H	HSDMP429	\$191	\$191
1	Return Kit 29½"H	HSDRK29	\$103	\$103
2	Freestanding Support Leg 24"D x 29½"H	HSDSL2429F	\$208	\$416
3	Freestanding End Panel Support 24"D x 29½"H	HSDEP2429F	\$198	\$594
1	Full-Height Modesty Panel 72"W x 29½"H	HSDMP729	\$211	\$211
3	Full-Height Modesty Panel 36"W x 29½"H	HSDMP369	\$187	\$561
1	Corner Desk Leg 29½"H	HSDDL29	\$168	\$168
TOTAL:			\$3,987	

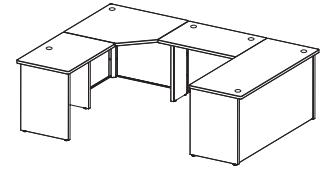

BRIDGE DESK

Attached between corner and primary desk

QTY	DESCRIPTION	MODEL	LIST PRICE	PRICE EXTENSION
1	Jetty – Right-Handed 48"D x 72"W x 24" x 30"	HWJ59ABRP	\$843	\$843
1	Corner Cove – Right-Handed 72" x 48" x 24" x 24"	HWV95AARP	\$834	\$834
2	Full-Height Modesty Panel 48"W x 29½"H	HSDMP489	\$198	\$396
1	Stand-Alone Corner Modesty Panel 72"W x 29½"H	HSDCMP7229	\$211	\$211
1	Freestanding End Panel Support 11"D x 29½"H	HSDEP1129F	\$187	\$187
1	Freestanding Support Leg 24"D x 29½"H	HSDSL2429F	\$208	\$208
1	Freestanding End Panel Support 24"D x 29½"H	HSDEP2429F	\$198	\$198
1	Corner Desk Leg 29½"H	HSDLL29	\$168	\$168
1	Support Column	HCNLEG29	\$217	\$217
TOTAL:			\$3,262	

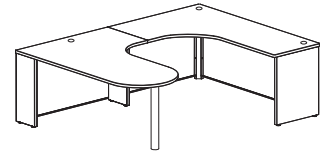

"U" WITH JETTY AND CORNER COVE

QTY	DESCRIPTION	MODEL	LIST PRICE	PRICE EXTENSION
4	Rectangular Worksurface 24"D x 72"W	HWR2472P	\$529	\$2,116
2	Abound® Panel Frame 35"H x 24"W	HRVF3524P	\$234	\$468
2	Abound® Panel Frame 35"H x 48"W	HRVF3548P	\$270	\$540
4	Abound® Fabric Tile 30"H x 24"W	HRVT3024T	\$100	\$400
4	Abound® Fabric Tile 30"H x 48"W	HRVT3048T	\$137	\$548
2	Abound® Frameless Glass 7½"H x 72"W	HRVT0772F	\$843	\$1,686
2	Abound® Finished End Trim 30"H	HRVC30PF	\$78	\$156
2	Abode™ Desk-to-Panel Attachment Kits – Left 29½"H	HSDDPA29L	\$100	\$200
2	Abode™ Desk-to-Panel Attachment Kits – Right 29½"H	HSDDPA29R	\$100	\$200
4	Abode™ Full-Height Modesty Panel 72"W	HSDMP729	\$211	\$844
4	Abode™ Freestanding End Panel 24"D	HSDEP2429F	\$198	\$792
2	Contain® Low Credenza, Box/Lateral – Right 48"W	HSCP224818LBFOM	\$1,618	\$3,236
2	Contain® Low Credenza, Box/Lateral – Left 48"W	HSCP224818RBFOM	\$1,618	\$3,236
4	Flagship® Freestanding Support Ped B/B/F	H19717A	\$687	\$2,748
4	Voi® Above Privacy Screen 60"W x 13"H	HLSL1260	\$462	\$1,848
4	Credenza Storage-to-Panel Bracket	HSCAPB	\$198	\$792
TOTAL:			\$19,810	

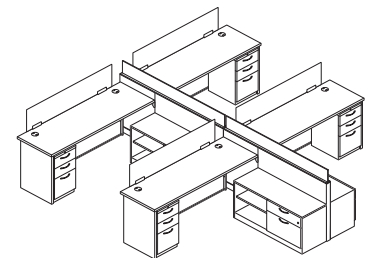

ABODE™ WITH ABOUND®

ABODE™ Typicals



Icon Legend on page 19

WORKSTATIONS

QTY	DESCRIPTION	MODEL	LIST PRICE	PRICE EXTENSION
2	Rectangular Worksurface 24"D x 36"W	HWR2436P	\$346	\$692
1	Corner Worksurface 24"D x 36"W	HWCS3624P	\$522	\$522
2	Abode™ Freestanding End Panel 24"D	HSDEP2429F	\$198	\$396
2	Abode™ Freestanding Support Leg 24"D	HSDSL2429F	\$208	\$416
1	Abode™ Corner Desk Leg 29½"H	HSDDL29	\$168	\$168
4	Abode™ Full-Height Modesty Panel 36"W	HSDMP369	\$187	\$748
2	Flagship® Freestanding Support Ped B/B/F	H19717A	\$687	\$1,374
TOTAL:			\$4,316	

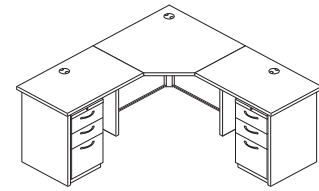

CORNER WITH RETURN

QTY	DESCRIPTION	MODEL	LIST PRICE	PRICE EXTENSION
8	Accelerate® Tackable Panel 65"H x 24"W	HETP6524FP	\$373	\$2,984
2	Accelerate® Tackable Panel 65"H x 48"W	HETP6548FP	\$479	\$958
6	Accelerate® Top Cap 24"W	HETC24	\$38	\$228
2	Accelerate® Top Cap 72"W	HETC72	\$103	\$206
4	Rectangular Worksurface 24"D x 72"W	HWR2472P	\$529	\$2,116
4	Rectangular Worksurface 24"D x 48"W	HWR2448P	\$404	\$1,616
2	Accelerate® "T" Connector 65"H	HEC65PT	\$158	\$316
1	Accelerate® "X" Connector 65"H	HEC65PX	\$158	\$158
6	Accelerate® Panel Finished End Covers 65"H	HEFEC65P	\$65	\$390
8	Accelerate® Worksurface Bracket Kit	HWSB2	\$47	\$376
4	Flat Bracket 24"D	HHN831124	\$64	\$256
4	Flagship® Freestanding Support Ped B/B/F	H19717A	\$687	\$2,748
2	Abode™ Desk-to-Panel Attachment Kits - Left 29½"H	HSDDPA29L	\$100	\$200
2	Abode™ Desk-to-Panel Attachment Kits - Right 29½"H	HSDDPA29R	\$100	\$200
4	Abode™ Freestanding End Panel 24"D	HSDEP2429F	\$198	\$792
4	Abode™ Full-Height Modesty Panel 72"W	HSDMP729	\$211	\$844
4	Systems Overhead Storage Flipper Door 48"W	HRVOH48FM	\$632	\$2,528
4	Systems Overhead Storage Shelf 24"W	HRVSH24	\$233	\$932
4	Voi® Above Privacy Screen 42"W x 13"H	HLSL1242	\$352	\$1,408
TOTAL:			\$19,256	

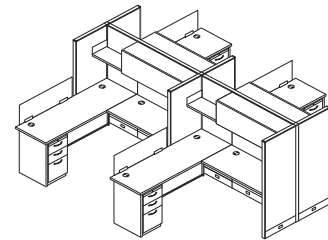

ABODE™ WITH ACCELERATE®

QTY	DESCRIPTION	MODEL	LIST PRICE	PRICE EXTENSION
1	Rectangular Worksurface 24"D x 72"W	HWR2472P	\$529	\$529
1	Rectangular Worksurface 24"D x 48"W	HWR2448P	\$404	\$404
1	Peninsula Worksurface 30"D x 72"W	HWP3072P	\$760	\$760
1	Stack-on Full Clearance w/o Doors 13"D x 72"W x 34¾"H	H386572N	\$929	\$929
1	Flipper Doors w/ Lock 36"W x 16"H	H387215	\$577	\$577
1	Tackboard for 72"W Hutch 72"	HT72ND	\$522	\$522
1	Support Column for Peninsula 29"H	HCNLEG29	\$217	\$217
2	Abode™ Freestanding End Panel 24"D	HSDEP2429F	\$198	\$396
1	Abode™ Freestanding End Panel 11"D	HSDEP1129F	\$187	\$187
1	Abode™ Freestanding Support Leg 24"D	HSDSL2429F	\$208	\$208
1	Abode™ Return Kit	HSDRK29	\$103	\$103
1	Abode™ Full-Height Modesty Panel 72"W	HSDMP729	\$211	\$211
1	Abode™ Full-Height Modesty Panel 54"W	HSDMP549	\$201	\$201
1	Abode™ Full-Height Modesty Panel 30"W	HSDMP309	\$185	\$185
1	Flagship® 2 Drawer "A" Pull Lateral 30"W	H9170A	\$992	\$992
TOTAL:			\$6,421	

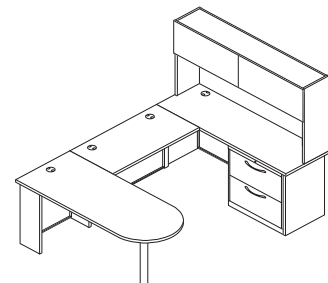

PENINSULA U



Icon Legend on page 19

ABODE™ Typicals

QTY	DESCRIPTION	MODEL	LIST PRICE	PRICE EXTENSION
2	Rectangular Worksurface 24"D x 72"W	HWR2472P	\$529	\$1,058
1	Height Adjustable Worksurface 24"D x 48"W	HHAW2448P	\$429	\$429
1	Stack-on Full Clearance w/o Doors 13"D x 72"W x 34¾"H	H386572N	\$929	\$929
1	Flipper Doors w/ Lock 36"W x 16"H	H387215	\$577	\$577
1	Tackboard for 72"W Hutch 72"	HT72ND	\$522	\$522
2	Abode™ Full-Height Modesty Panel 72"W	HSDMP729	\$211	\$422
4	Abode™ Freestanding End Panel 24"D	HSDEP2429F	\$198	\$792
1	Systems Height Adjustable Base 24"D	HHAB3S2L	\$1,120	\$1,120
2	Flagship® 2 Drawer "A" Pull Lateral 30"W	H9170A	\$992	\$1,984
TOTAL:			\$7,833	

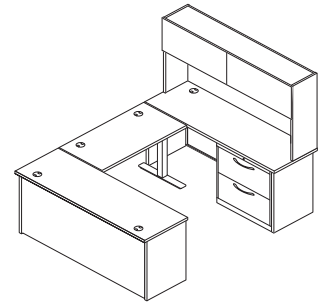

WORKSTATION U

WORKSTATIONS

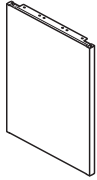

DESCRIPTION

Freestanding End Panel Supports

11"D
24"D
30"D

MODEL

HSDEP1129F
HSDEP2429F
HSDEP3029F

SHIP WEIGHT

15 **Ⓢ**
25 **Ⓢ**
30 **Ⓢ**

CUBE

1.1
1.1
1.1

LIST PRICE BY PAINT GRADE

P1 **P2**

\$187 **\$214**
\$198 **\$225**
\$220 **\$247**

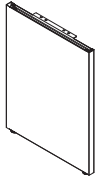

Panel Mounted Full End Panel Supports*

29½"H x 11"D — Right — Panel Mount
29½"H x 11"D — Left — Panel Mount
29½"H x 24"D — Right — Panel Mount
29½"H x 24"D — Left — Panel Mount
29½"H x 30"D — Right — Panel Mount
29½"H x 30"D — Left — Panel Mount

HRVEP1129R
HRVEP1129L
HRVEP2429R **Ⓢ**
HRVEP2429L **Ⓢ**
HRVEP3029R
HRVEP3029L

16 **Ⓢ** 1.4
16 **Ⓢ** 1.4
21 **Ⓢ** 1.4
21 1.4
23 1.4
23 1.4

\$207 **\$236**
\$207 **\$236**
\$223 **\$252**
\$223 **\$252**
\$242 **\$271**
\$242 **\$271**

! *Must be connected into panel slots. When an installation of worksurfaces is 8 feet or greater, a full end panel or universal support leg must be used at 90 degree panel junctions or in a shared position to support adjoining worksurfaces.

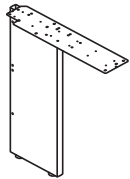

Freestanding Support Leg

24"D
30"D

HSDSL2429F
HSDSL3029F

25 **Ⓢ** 1.1
25 **Ⓢ** 1.1

\$208 **\$235**
\$234 **\$261**

NOTES: To be used when connecting a non-rectangular worksurface to a rectangular worksurface.

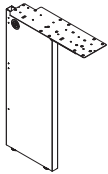

Panel Mounted Support Leg*

29½"H to support 24"D
29½"H to support 30"D

HRVCLG24 **Ⓢ**
HRVCLG30

16 **Ⓢ** 1.4
17 **Ⓢ** 1.4

\$197 **\$226**
\$215 **\$244**

! *Must be connected into panel slots. When an installation of worksurfaces is 8 feet or greater, a full end panel or universal support leg must be used at 90 degree panel junctions or in a shared position to support adjoining worksurfaces.

Non-handed unit
Specify paint







NOTES:

! All Abode™ Components are compatible with Abound® and Accelerate® panel systems and Systems Worksurfaces.

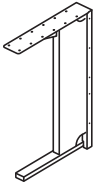
HOW TO SPECIFY

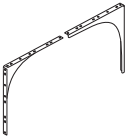
Select Model Number	Select Paint Color
	See page 382
H S D E P 1 1 2 9 F .	T 1



	DESCRIPTION	MODEL	SHIP WEIGHT	CUBE	LIST PRICE BY PAINT GRADE	
					P1	P2
	Abode™ Shared Leg NOTES: To be used when joining two rectangular surfaces. Can be used as a stand-alone support in panel systems. 1/2" radius opening for cord management.	HDSL29	18	1.5	\$380	\$407
	Corner Desk Leg 29 1/2" H NOTES: Corner desk legs have 90° bend and welded construction.	HDDL29	7	0.4	\$168	\$195
	Gussets (1 pair) NOTES: Gussets may be used instead of a modesty panel to create freestanding desks 36" W to 60" W.	HSDG	7	0.5	\$116	\$133
	Flat Bracket 24" D 30" D  Charcoal only.	HHN831124  HHN831130	3 3	0.3 0.4	\$64 \$64	N/A N/A

NOTES:

 All Abode™ Components are compatible with Abound® and Accelerate® panel systems and Systems Worksurfaces.

EXTERNAL CHANNEL SELECTION GUIDE						
Support Combination		Worksurface Width for Rectangle, Wedge, and Saddle				
Support 1	Support 2	84 in	72 in	66 in	60 in	54 in
O-Leg	O-Leg	NA	HLSLZ5SC72	HLSLZ5SC66	HLSLZ5SC60	HLSLZ5SC54
O-Leg	Slim Profile Pedestal	HLSLZ5SC84	HLSLZ5SC66	HLSLZ5SC60	HLSLZ5SC54	NA
O-Leg	Bookcase	HLSLZ5SC72	HLSLZ5SC66	HLSLZ5SC60	HLSLZ5SC54	NA
O-Leg	Pedestal	HLSLZ5SC72	HLSLZ5SC60	HLSLZ5SC54	NA	NA
O-Leg	End-Panel	HLSLZ5SC84	HLSLZ5SC60	HLSLZ5SC54	NA	NA
Slim Profile Pedestal	Slim Profile Pedestal	HLSLZ5SC72	HLSLZ5SC60	HLSLZ5SC54	NA	NA
Slim Profile Pedestal	Bookcase	HLSLZ5SC72	HLSLZ5SC60	HLSLZ5SC54	NA	NA
Slim Profile Pedestal	Pedestal	HLSLZ5SC66	HLSLZ5SC54	NA	NA	NA
Slim Profile Pedestal	End-Panel	HLSLZ5SC66	HLSLZ5SC54	NA	NA	NA
Pedestal	Bookcase	HLSLZ5SC66	HLSLZ5SC54	NA	NA	NA
End-Panel	Bookcase	HLSLZ5SC66	HLSLZ5SC54	NA	NA	NA
Bookcase	Bookcase	HLSLZ5SC66	HLSLZ5SC54	NA	NA	NA
End-Panel	End-Panel	HLSLZ5SC60	NA	NA	NA	NA
Pedestal	Pedestal	HLSLZ5SC60	NA	NA	NA	NA
Pedestal	End-Panel	HLSLZ5SC60	NA	NA	NA	NA
O-Leg	Lateral/Multifile	HLSLZ5SC54	NA	NA	NA	NA
Bookcase	Lateral/Multifile	NA	NA	NA	NA	NA
Slim Profile Pedestal	Lateral/Multifile	NA	NA	NA	NA	NA
Pedestal	Lateral/Multifile	NA	NA	NA	NA	NA
End-Panel	Lateral/Multifile	NA	NA	NA	NA	NA

*All Rudder worksurfaces use external channel model HLSLZ5SC60.

HOW TO SPECIFY

<p>Select Model Number</p> <p>H S D S L 2 9</p>	<p>Select Paint Color</p> <p>See page 382</p> <p>T 1</p>
--	---

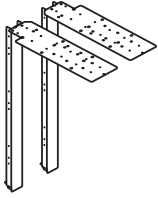

DESCRIPTION	MODEL	SHIP WEIGHT	CUBE	LIST PRICE BY PAINT GRADE	
				P1	P2
Bridge Kit 29½"H NOTES: Add 12" to your modesty width when using a Bridge Kit. Bridge Kits include two flat brackets, two modesty panel-to-end panel attachment brackets, and two tie straps.	HSDBK29	10	0.4	\$197	\$224

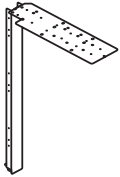

Return Kit 29½"H NOTES: Add 6" to your modesty width when using a Return Kit. Return Kits include one flat bracket, one modesty panel-to-end panel attachment bracket, and one tie strap.	HSDRK29	6	0.4	\$103	\$130
--	----------------	---	-----	--------------	--------------



Desk-to-Panel Attachment Kit 29½"H 29½"H	HSDDPA29L	5	0.3	\$100	\$110
	HSDDPA29R	5	0.3	\$100	\$110



Corner with Desk-to-Panel Attachment Kit 29½"H 29½"H NOTES: This Attachment Kit utilizes the same modesty panel specification rules as the Freestanding Corner Leg.	HSDCPA29L	5	0.3	\$100	\$110
	HSDCPA29R	5	0.3	\$100	\$110

HOW TO SPECIFY

<p>Select Model Number</p> <p>H S D B K 2 9 . T 1</p>	<p>Select Paint Color</p> <p>See page 382</p>
--	--



	DESCRIPTION	MODEL	SHIP WEIGHT	CUBE	LIST PRICE BY PAINT GRADE	
					P1	P2
	Full-Height Modesty Panel					
	29½”H x 24”W	HSDMP249	5.0 Ⓢ	0.6	\$179	\$196
	29½”H x 30”W	HSDMP309	7.0 Ⓢ	0.6	\$185	\$202
	29½”H x 36”W	HSDMP369	8.0	0.8	\$187	\$204
	29½”H x 42”W	HSDMP429	9.0	0.9	\$191	\$208
	29½”H x 48”W	HSDMP489	11.0	1.0	\$198	\$215
	29½”H x 54”W	HSDMP549	12.0	2.2	\$201	\$218
	29½”H x 60”W	HSDMP609	13.0	2.2	\$203	\$220
	29½”H x 66”W	HSDMP669	15.0	2.6	\$208	\$225
	29½”H x 72”W	HSDMP729	16.0	3.0	\$211	\$228
! To be used in all applications except when connecting a Corner Leg to an End Panel or a Corner Leg to a Shared Leg.						
	Full-Height Stand-Alone Corner Modesty Panel					
	29½”H x 36”W	HSDCMP3629	7.0	1.9	\$187	\$204
	29½”H x 42”W	HSDCMP4229	9.0	1.9	\$191	\$208
	29½”H x 48”W	HSDCMP4829	10.0	2.3	\$198	\$215
	29½”H x 60”W	HSDCMP6029	14.0	4.7	\$203	\$220
	29½”H x 72”W	HSDCMP7229	16.0	5.4	\$211	\$228
NOTES: To be used when connecting a Corner Leg to an End Panel or Shared Leg.						
	Half-Height Modesty Panel					
	14”H x 24”W	HSDMP244	5.1 Ⓢ	0.4	\$167	\$184
	14”H x 30”W	HSDMP304	6.6 Ⓢ	0.4	\$171	\$188
	14”H x 36”W	HSDMP364	8.1 Ⓢ	0.5	\$174	\$191
	14”H x 42”W	HSDMP424	9.6 Ⓢ	0.6	\$184	\$201
	14”H x 48”W	HSDMP484	11.0 Ⓢ	0.6	\$187	\$204
	14”H x 54”W	HSDMP544	13.0 Ⓢ	0.8	\$190	\$207
	14”H x 60”W	HSDMP604	14.0 Ⓢ	0.8	\$192	\$209
	14”H x 66”W	HSDMP664	16.0 Ⓢ	1.0	\$198	\$215
	14”H x 72”W	HSDMP724	17.0 Ⓢ	1.0	\$201	\$218
	Half-Height Stand-Alone Corner Modesty Panel					
	14”H x 36”W	HSDCMP3614	4.0 Ⓢ	0.5	\$174	\$191
	14”H x 42”W	HSDCMP4214	4.0 Ⓢ	0.6	\$184	\$201
	14”H x 48”W	HSDCMP4814	5.0 Ⓢ	0.6	\$187	\$204
	14”H x 60”W	HSDCMP6014	6.0 Ⓢ	0.8	\$192	\$209
	14”H x 72”W	HSDCMP7214	7.0 Ⓢ	1.0	\$201	\$218

NOTES:

- Desk: Modesty panel width is the same width as the worksurface.
- Return: Modesty panel width is 6” greater than the width of the return worksurface.
- Bridge connecting two rectangular worksurfaces: Modesty panel width is 12” greater than the width of the bridge worksurface.
- Bridge connecting a rectangular worksurface and corner or peninsula: Modesty panel width is 6” greater than the width of the worksurface.
- Corner connecting to an adjacent worksurface: Modesty panel width is the same width as the worksurface.

HOW TO SPECIFY

<p>Select Model Number</p> <p>H S D M P 2 4 9 .</p>	<p>Select Paint Color</p> <p>See page 382</p> <p>T 1</p>
---	--

ABOUND®



Abound® shown with Contain® Storage, Ignition® Seating, and Voi® Desking.

ABOUND®

High-performance workspaces? Abound set the standard, and set it high. With its mixed materials and multiple design options, Abound lets you mix and match the beautiful and the functional to customize your office — from reception areas to private offices and every space in between. Flexibility. Personality. Durability. Quality! Abound delivers all this and more.



FEATURES

- With multiple tile options, materials and fabrics, Abound supports a variety of work styles and office budgets.
- Top channel lay-in or beltline capabilities expand your cabling capacity.
- Open Base frame option brings a lighter scale aesthetic and allows for easier cleaning.
- Straight lines, crisp edges and rectilinear worksurfaces fit precisely together to create a tailored, architectural presence.
- With a variety of layout options and compatibility with HON storage, height adjustable bases and freestanding desks, the options with Abound are endless.

ABOUT® ORDERING INFORMATION

GALLERY PANELS, WORKSURFACES, COUNTERTOPS, CORNER SHELVES W/EDGE BAND, HARD-SURFACE TILE OVERHEAD STORAGE DOORS*

L1 LAMINATES CODES

Woodgrain

- ◆ Bourbon Cherry H
- ◆ Cognac COGN
- ◆ Florence Walnut LFW1
- ◆ Harvest C
- ◆ Kingswood Walnut LK11
- ◆ Mahogany N
- ◆ Mocha MOCH
- ◆ Natural Maple D
- ◆ Pinnacle PINC
- ◆ Shaker Cherry F
- ◆ Sterling Ash LSA1

Solid

- ◆ Black P
- ◆ Charcoal S
- ◆ Designer White LDW1
- ◆ Loft LOFT

Patterned

- ◆ Sheer Mesh A5
- ◆ Silver Mesh B9
- ◆ Steel Mesh A9
- ◇ Canyon Zephyr K9
- ◇ Desert Zephyr K8
- ◇ Shadow Zephyr K1
- ◆ Gray G2
- ◆ Grey Tigris L6
- ◇ White G1
- ◆ Whitestone K4

L2 LAMINATES CODES

Woodgrain

- ◆ Lowell Ash LLA1
- ◆ Natural Recon LNRI
- ◆ Phantom Ecru LPE1
- ◆ Portico Teak LPT1
- ◆ Skyline Walnut LSW1

(Door panels not available in L2)

► LAMINATE TOPS

SPECIFY: Model Number.

Laminate

Edge Color

Grommet Color

EXAMPLE: HWR2424P.K8.R.T5

► PAINTED PRODUCTS

SPECIFY: Model Number.

Paint Color

EXAMPLE: HRVSHV24.T1

► PANEL FRAMES

SPECIFY: Model Number.

Paint

EXAMPLE: HRVF3524P.T3

Suffix "A"



Satin Chrome
Arch Pull

* Laminate Front Overheads only available in L1 Woodgrain Laminates.

◆◆◆ For lead time information see page 19.

* De-emphasized

WORKSURFACE EDGE BAND

- ◆ Black P
- ◆ Bourbon Cherry H
- ◆ Charcoal S
- ◆ Cognac COGN
- ◆ Designer White DW
- ◆ Florence Walnut FW
- ◆ Greige R
- ◆ Harvest C
- ◆ Kingswood Walnut KI
- ◆ Light Gray Q
- ◆ Loft LOFT
- ◆ Lowell Ash DL
- ◆ Mahogany N
- ◆ Mocha MOCH
- ◆ Muslin T
- ◆ Natural Maple D
- ◆ Natural Recon NR
- ◆ Phantom Ecru PE
- ◆ Pinnacle PINC
- ◆ Platinum K
- ◆ Portico Teak DP
- ◇ Shadow * SHDW
- ◆ Shaker Cherry F
- ◆ Skyline Walnut SW
- ◆ Sterling Ash SA

WORKSURFACE GROMMET

- PLASTIC CODES
- ◆ Black P
- ◆ Brownstone EY
- ◆ Charcoal S
- ◆ Fossil EH
- ◆ Greige T5
- ◆ Light Gray Q
- ◆ Loft LOFT
- ◆ Muslin T3
- ◆ Shadow * SHDW
- ◆ Titanium TI
- ◆ Designer White DW
- ◆ Champagne Metallic T4
- ◆ Platinum Metallic T1

Edge Treatments



"P" Edgeband

(Color must be selected.)

► HOW TO ORDER

- 1) Select desired model numbers.
- 2) Order worksurfaces to correspond to width of panel behind them.
- 3) Add appropriate prefix and suffix if Tee-Span worksurfaces are needed.

FRAMES, TRIM, METAL TILES, CUSTOM BRACKET KIT, WORKSURFACE SUPPORTS, STEEL OVERHEAD STORAGE CHASSIS

PAINT CODES

P1

- ◆ Black P
- ◆ Brownstone P7D
- ◆ Charcoal S
- ◆ Designer White PJW
- ◆ Fossil P28
- ◆ Greige T5
- ◆ Light Gray Q
- ◆ Loft LOFT
- ◆ Muslin T3
- ◆ Putty L
- ◆ Shadow * SHDW
- ◆ Titanium P8T

P2

- ◆ Champagne Metallic T4
- ◆ Platinum Metallic T1
- ◆ Silver PR6
- ◆ Solar Black P8X

DUPLEX/PORTED TILE

PLASTIC CODES

- ◆ Black P
- ◆ Charcoal S
- ◆ Designer White DW
- ◆ Loft LOFT
- ◆ Muslin T3
- ◆ Titanium TI

Recommendations

Paint	Duplex-Data Code
Black P	Black P
Brownstone P7D	Brownstone EY
Charcoal S	Charcoal S
Designer White PJW	Designer White DW
Fossil P28	Charcoal S
Greige T5	Muslin T3
Light Gray Q	Loft LOFT
Loft LOFT	Loft LOFT
Muslin T3	Muslin T3
Putty L	Black P
Shadow SHDW	Muslin T3
Silver PR6	Titanium TI
Titanium P8T	Titanium TI
Champagne Metallic T4	Muslin T3
Platinum Metallic T1	Titanium TI

ABOUND[®] FABRIC PATTERNS & CODES

PRICE CODE AA

FACTOR	FACT
◆ Bark	FACT20
◆ Barley	FACT15
◆ Cascade	FACT25
◆ Feather	FACT30

PRICE CODE A

APPOINT	APN
◆ Artichoke	APN11
◆ Blackberry	APN32
◆ Bronze	APN22
◆ Carbon	APN28
◆ Chai	APN12
◆ Cherry	APN30
◆ Dark Pewter	APN17
◆ Dune	APN15
◆ Espresso	APN23
◆ Framboise	APN31
◆ Frost	APN34
◆ Jet	APN27
◆ Lawn	APN25
◆ Mandarin	APN29
◆ Morel	APN09
◆ Nimbus	APN16
◆ Platinum	APN24
◆ Turquoise	APN26

CENTURION CU

Not available on heights over 54"H

◆ Apricot	CU47
◆ Bark	CU25
◆ Black	CU10
◆ Espresso	CU49
◆ Fog	CU03
◆ Frost	CU22
◆ Goldenrod	CU27
◆ Indigo	CU06
◆ Iris	CU50
◆ Iron Ore	CU19
◆ Jade	CU83
◆ Marsala	CU63
◆ Morel	CU24
◆ Navy	CU98
◆ Peacock	CU97
◆ Pear	CU84
◆ Ruby	CU67
◆ Sapphire	CU09

PRICE CODE A *continued*

ETCH*	ECH
◆ Axis	ECH13
◆ Blend	ECH14
◆ Cast	ECH12
◆ Highlight	ECH10
◆ Midtone	ECH11
◆ Outline	ECH08
◆ Shade	ECH09
◆ Tonal	ECH16
◆ Vanish	ECH15

EXCHANGE* EXG

◆ Iron	EXG916
◆ Nickel	EXG914
◆ Pistachio	EXG910
◆ Root	EXG913
◆ Rupee	EXG903
◆ Shadow	EXG911
◆ Silver	EXG915
◆ Sisal	EXG917
◆ Stone	EXG912

LANDSCAPE* LN

◆ Azure	LN55
◆ Cornsilk	LN15
◆ Drift	LN05
◆ Khaki	LN20
◆ Sheen	LN10
◆ Slate	LN35
◆ Umber	LN25
◆ Urban	LN30

LUCY* LC

◆ Aspen	LC32
◆ Cornsilk	LC30
◆ Dusk	LC22
◆ Fawn	LC33
◆ Graphite	LC34
◆ Mist	LC20
◆ Neutra	LC24
◆ Pewter	LC35
◆ Snowdrop	LC28

PRICE CODE A *continued*

REFLECTIONS*	REF
◆ Galvanized	REF29
◆ Ice	REF20
◆ Loggia	REF21
◆ Mistral	REF28
◆ Moonstone	REF23
◆ Pewter	REF22
◆ Stainless	REF24
◆ Vanilla	REF25
◆ Winter	REF27

REFUGE* RFG

◆ Artesian	RFG96
◆ Dune	RFG92
◆ Eclipse	RFG90
◆ Frost	RFG93
◆ Glacier	RFG91
◆ Mineral	RFG98
◆ Tidal	RFG94

SARTO* SRT

◆ Ash	SRT88
◆ Fog	SRT14
◆ Lemongrass	SRT49
◆ Mist	SRT45
◆ Mushroom	SRT76
◆ Oyster	SRT18
◆ Reef	SRT64
◆ Sesame	SRT93
◆ Shale	SRT52

TEMPEST* TP

◆ Dragonfly	TP30
◆ Frost	TP15
◆ Full Stream	TP80
◆ Gold Rush	TP10
◆ Slate	TP45
◆ Tumbleweed	TP70
◆ Wind Chill	TP40
◆ Zebra	TP35

NOTES: Analog, Disperse, and Exchange panel fabrics will be applied pattern cut. Disperse will not be available on 72"W panels.

◆◆◆ For lead time information see page 19.

* Directional fabrics

ABOUND[®] FABRIC PATTERNS & CODES

PRICE CODE B

ANALOG*	ANLG
◆ Album	ANLG06
◆ Cartridge	ANLG04
◆ Cassette	ANLG09
◆ Dial	ANLG02
◆ Media	ANLG08
◆ Reel	ANLG07
◆ Signal	ANLG03
◆ Stereo	ANLG01
◆ Track	ANLG05

COAST*	COA
◆ Channel	COA14
◆ Dune	COA03
◆ Headlands	COA10
◆ Marsh	COA02
◆ Pebble	COA12
◆ Pier	COA13
◆ Shoal	COA01
◆ Silt	COA06
◆ Tide	COA08

DISPERSE*	DISP
◆ Autumn	DISP03
◆ Branch	DISP10
◆ Coffee Bean	DISP13
◆ Dusk	DISP09
◆ Emerald City	DISP08
◆ Gold Rush	DISP02
◆ Igloo	DISP11
◆ Ink	DISP06
◆ Mist	DISP12
◆ Oatmeal	DISP15
◆ Prince	DISP07
◆ Reservoir	DISP01
◆ Rose	DISP04
◆ Spring	DISP05
◆ Steel	DISP16
◆ Taupe	DISP14

PRICE CODE B *continued*

MICA*	MCA
◆ Anthracite	MCA11
◆ Breeze	MCA18
◆ Bronze	MCA13
◆ Buff	MCA14
◆ Cremini	MCA17
◆ Crystal	MCAWIT
◆ Dew	MCA20
◆ Dove	MCA12
◆ Fresh	MCA16
◆ Mineral	MCA15
◆ Nectar	MCA19
◆ Shale	MCA10

SPIN*	SPIN
◆ Alabaster	SPIN02
◆ Cavern	SPIN03
◆ Cobblestone	SPIN04
◆ Ember	SPIN06
◆ Flame	SPIN07
◆ Heron	SPIN13
◆ Oat	SPIN01
◆ Ocean	SPIN12
◆ Plum	SPIN15
◆ Pool	SPIN11
◆ Raven	SPIN10
◆ Rhubarb	SPIN14
◆ Tropic	SPIN08
◆ Willow	SPIN05

PRICE CODE B *continued*

TERRAIN*	TRRN
◆ Bay	TRRN05
◆ Bayou	TRRN35
◆ Canyon	TRRN30
◆ Cliff	TRRN45
◆ Crest	TRRN25
◆ Delta	TRRN10
◆ Plateau	TRRN15
◆ Ridge	TRRN20
◆ Valley	TRRN40

NOTES: Disperse panel fabric is applied pattern cut and is not available on 72"W Accelerate[®] panels or on 66"W tackboards, Voi[®] screens, and Empower[®].

Analog and Exchange panel fabric is applied pattern cut and is not available on 78"W tackboards, Voi[®] screens, and Empower[®].

◆◆◆ For lead time information see page 19.

* Directional fabrics

ABOUND[®] Typicals



Icon Legend on page 19

WORKSTATIONS

QTY	DESCRIPTION	MODEL	LIST PRICE	PRICE EXTENSION
1	Flagship Series Pedestal "R" Pull Freestanding B/B/F	H19723R	\$739	\$739
1	Flagship 30"W 2-Drw "R" Pull Lateral 30"W x 28"H x 18"D	H9170R	\$992	\$992
2	Electrical Power Harness 3-1 & 2-2 Systems 36"W	HH871236	\$206	\$412
1	Circuit 1	HH873501	\$42	\$42
1	Circuit 4	HH873504	\$42	\$42
1	Base In-Feed Cable Base 3-1 & 2-2 Systems	HH879072	\$229	\$229
2	Abound Finished End Painted 65"	HRVC65PF	\$99	\$198
3	Abound L Connector Painted 65"	HRVC65PL	\$162	\$486
6	Abound Panel Frame 65"H x 36"W	HRVF6536P	\$289	\$1,734
6	Abound Top Cap Trim 36"W	HRVTC36	\$58	\$348
1	Cantilever One Pair 24"D	HCTL242	\$83	\$83
24	Abound Segment Bar 36"W	HRVFSB36	\$22	\$528
1	Abound Overhead Metal Flipper Door 36"	HRVOH36FM	\$577	\$577
24	Abound Fabric Tile 15"H x 36"W	HRVT1536T	\$73	\$1,752
12	Abound Fabric Tile 30"H x 36"W	HRVT3036T	\$100	\$1,200
1	Systems Rectangular Worksurface Edgeband 24"D x 36"W	HWR2436P	\$346	\$346
1	Systems Left Corner Cove Worksurface Edgeband 72" x 36" x 24" x 24"	HWV93AALP	\$668	\$668
TOTAL:				\$10,376

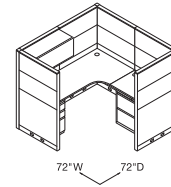

L-SHAPE WORKSTATION
72" W x 72" D

QTY	DESCRIPTION	MODEL	LIST PRICE	PRICE EXTENSION
1	Electrical Power Harness 3-1 & 2-2 Systems 48"W	HH871248	\$216	\$216
1	Circuit 1	HH873501	\$42	\$42
1	Circuit 4	HH873504	\$42	\$42
1	Base In-Feed Cable Base 3-1 & 2-2 Systems	HH879072	\$229	\$229
1	Overhead Cabinet w/Sliding Door 48"W x 14 1/4"D x 14"H	HLSL1448S	\$1,100	\$1,100
1	Mobile Ped 20" x 15 1/8" x 21 1/2"	HLSL2016MP2	\$813	\$813
1	Ped Cushion (Fabric Grade 2) 20" x 15 1/8" x 1"	HLSL2016PH2	\$339	\$339
1	Stack-on Storage Panel Mounted Bracket	HLSLPMB	\$131	\$131
2	Rectangle Worksurface 24"D x 48" W	HLSLR2448	\$306	\$612
1	Personal Storage Tower (RH) 24"D x 24"W x 65"H	HLSLW446RP	\$2,660	\$2,660
1	Abound Variable Height Finished End Painted 15"	HRVC15PFV	\$64	\$64
1	Abound Finished End Painted 50"	HRVC50PF	\$94	\$94
1	Abound L Connector Painted 50"	HRVC50PL	\$153	\$153
1	Abound Finished End Painted 65"	HRVC65PF	\$99	\$99
2	Abound L Connector Painted 65"	HRVC65PL	\$162	\$324
1	Abound Panel Frame 50"H x 24"W	HRVF5024P	\$257	\$257
1	Abound Panel Frame 50"H x 48"W	HRVF5048P	\$293	\$293
3	Abound Panel Frame 65"H x 24"W	HRVF6524P	\$278	\$834
1	Abound Panel Frame 65"H x 48"W	HRVF6548P	\$318	\$318
4	Abound Top Cap Trim 24"W	HRVTC24	\$35	\$140
2	Abound Top Cap Trim 48"W	HRVTC48	\$67	\$134
1	Flat Bracket 24"D	HHN831124	\$64	\$64
2	Abound Segment Bar 24"W	HRVFSB24	\$21	\$42
2	Abound Segment Bar 48"W	HRVFSB48	\$24	\$48
1	Abound 15" High Clear Glass Tile 15"H x 24"W	HRVT1524G	\$467	\$467
1	Abound 15" High Clear Glass Tile 15"H x 48"W	HRVT1548G	\$600	\$600
2	Abound Fabric Tile 30"H x 24"W	HRVT3024T	\$89	\$178
2	Abound Fabric Tile 30"H x 48"W	HRVT3048T	\$121	\$242
6	Abound Fabric Tile 60"H x 24"W	HRVT6024T	\$132	\$792
2	Abound Fabric Tile 60"H x 48"W	HRVT6048T	\$214	\$428
1	Bracket to Attach Towers to Worksurfaces	HSTB2W1	\$79	\$79
2	Worksurface Bracket Kit	HWSB2	\$47	\$94
TOTAL:				\$11,928

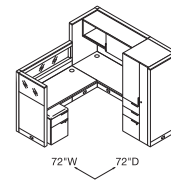

L-SHAPE WORKSTATION WITH STORAGE TOWER
72" W x 72" D



Icon Legend on page 19

ABOUND[®] Typicals

QTY	DESCRIPTION	MODEL	LIST PRICE	PRICE EXTENSION
2	Electrical Pass-Thru Cable 3-1 & 2-2 Systems 60"W	HH871160	\$136	\$272
1	Electrical Power Harness 3-1 & 2-2 Systems 24"W	HH871224	\$206	\$206
1	Circuit 1	HH873501	\$42	\$42
1	Circuit 2	HH873502	\$42	\$42
1	Circuit 3	HH873503	\$42	\$42
1	Circuit 4	HH873504	\$42	\$42
1	Base In-Feed Cable Base 3-1 & 2-2 Systems	HH879072	\$229	\$229
6	Abound Finished End Painted 50"	HRVC50PF	\$94	\$564
2	Abound T Connector Painted 50"	HRVC50PT	\$153	\$306
1	Abound X Connector Painted 50"	HRVC50PX	\$148	\$148
6	Abound Panel Frame 50"H x 24"W	HRVF5024P	\$257	\$1,542
2	Abound Panel Frame 50"H x 60"W	HRVF5060P	\$322	\$644
6	Abound Top Cap Trim 24"W	HRVTC24	\$35	\$210
2	Abound Top Cap Trim 60"W	HRVTC60	\$82	\$164
8	Worksurface Bracket Kit	HWSB2	\$47	\$376
12	Abound Segment Bar 24"W	HRVFSB24	\$21	\$252
4	Abound Segment Bar 60"W	HRVFSB60	\$25	\$100
4	Abound Open Shelf 60"	HRVSH60	\$357	\$1,428
12	Abound Fabric Tile 15"H x 24"W	HRVT1524T	\$65	\$780
4	Abound Fabric Tile 15"H x 60"W	HRVT1560T	\$94	\$376
12	Abound Fabric Tile 30"H x 24"W	HRVT3024T	\$89	\$1,068
4	Abound Fabric Tile 30"H x 60"W	HRVT3060T	\$136	\$544
4	Systems Rectangular Worksurface Edgeband 24"D x 60"W	HWR2460P	\$477	\$1,908
TOTAL:			\$11,285	

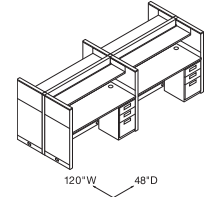

TOUCH-DOWN STATION
120"W x 48"D

QTY	DESCRIPTION	MODEL	LIST PRICE	PRICE EXTENSION
2	External Stiffener 72"W	HLSLZ5SC72	\$110	\$220
2	Abound Panel Frame 35"H x 30"W	HRFF3530P	\$240	\$480
4	Abound Fabric Tile 30"H x 30"W	HRVT3030T	\$93	\$372
4	Abound Panel Frame 35"H x 36"W	HRFF3536P	\$245	\$980
8	Abound Fabric Tile 30"H x 36"W	HRVT3036T	\$100	\$800
2	Abound Panel Frame 35"H x 42"W	HRFF3542P	\$255	\$510
4	Abound Fabric Tile 30"H x 42"W	HRVT3042T	\$113	\$452
2	Abound Finished End Painted 35"	HRVC35PF	\$78	\$156
2	Abound L Connector Painted 35"	HRVC35PL	\$136	\$272
4	Frameless Frosted Glass 15"H x 72"W	HRVT1572F	\$946	\$3,784
2	Contain [®] 35 LB Credenza Counterweight Kit	HSCACW35	\$199	\$398
2	Contain [®] Credenza Cushion (Fabric Grade 2) 36"W x 18"D	HSCAUC1836	\$320	\$640
2	Worksurface O-Leg 6½"H x 30"W	HSCAWS6530	\$228	\$456
1	Contain [®] Footed Metal Credenza with Laminate Front, Left 22" x 72" x 18"	HSCF227218BFOL	\$2,316	\$2,316
1	Contain [®] Footed Metal Credenza with Laminate Front, Right 22" x 72" x 18"	HSCF227218LBFOL	\$2,316	\$2,316
2	Systems Rectangular Worksurface Edgeband 30"D x 72"W	HWR3072P	\$593	\$1,186
2	Worksurface Bracket Kit	HWSB2	\$47	\$94
TOTAL:			\$15,432	

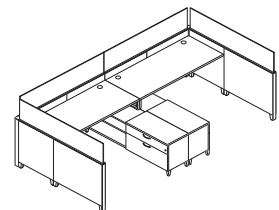

U-SHAPE TEAMING STATION
144"W x 72"D

ABOUND® Open Base Typicals



Icon Legend on page 19

WORKSTATIONS

QTY	DESCRIPTION	MODEL	LIST PRICE	PRICE EXTENSION
1	Abound Panel Frame 50"H x 24"W	HRFF5024P	\$257	\$257
2	Abound Fabric Tile 30"H x 24"W	HRVT3024T	\$89	\$178
1	Abound 15" High Clear Glass Tile 12"H x 24"W	HRVT1524G	\$467	\$467
2	Abound 24"W Segment Bar	HRVFSB24	\$21	\$42
1	Abound Panel Frame 50"H x 48"W	HRFF5048P	\$293	\$293
2	Abound Fabric Tile 30"H x 48"W	HRVT3048T	\$121	\$242
1	Abound 15" High Clear Glass Tile 15"H x 48"W	HRVT1548G	\$600	\$600
2	Abound 48"W Segment Bar	HRVFSB48	\$24	\$48
3	Abound Panel Frame 65"H x 24"W	HRFF6524P	\$278	\$834
6	Abound Fabric Tile 60"H x 24"W	HRVT6024T	\$132	\$792
1	Abound Panel Frame 65"H x 48"W	HRFF6548P	\$318	\$318
2	Abound Fabric Tile 60"H x 48"W	HRVT6048T	\$214	\$428
1	Overhead Cabinet with Sliding Door 48"W x 14 1/4"D x 14"H	HLSL1448S	\$1,100	\$1,100
1	Mobile Ped 20" x 15 1/8" x 21 1/2"	HLSL2016MP2	\$813	\$813
1	Ped Cushion 20" x 15 1/8" x 1"	HLSL2016PH2	\$339	\$339
1	Stack-on Storage Panel Mounted Bracket	HLSLPMB	\$131	\$131
1	Personal Storage Tower (RH) 24"D x 24"W x 65"H	HLSLW446RP	\$2,660	\$2,660
1	Abound Variable Height Finished End Painted 15"	HRVC15PFV	\$64	\$64
1	Abound Finished End Painted 50"	HRVC50PF	\$94	\$94
1	Abound L Connector Painted 50"	HRVC50PL	\$153	\$153
1	Abound Finished End Painted 65"	HRVC65PF	\$99	\$99
2	Abound L Connector Painted 65"	HRVC65PL	\$162	\$324
1	Bracket to Attach Towers to Worksurfaces	HSTB2W1	\$79	\$79
2	Systems Rectangular Worksurface Edgeband 24"D x 48"W	HWR2448P	\$404	\$808
2	Worksurface Bracket Kit	HWSB2	\$47	\$94
1	Abound Top Cap Trim 24"W	HRVTC24	\$35	\$35
1	Abound Top Cap Trim 48"W	HRVTC48	\$67	\$67
1	Abound Top Cap Trim 72"W	HRVTC72	\$102	\$102
1	Flat Bracket 24"D	HHN831124	\$64	\$64
TOTAL:			\$11,525	

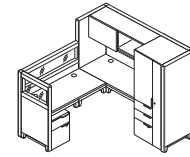

**L-SHAPE WORKSTATION
WITH STORAGE TOWER**

72"W x 72"D

ABOUND[®] FRAMES OVERVIEW

PANEL FRAME

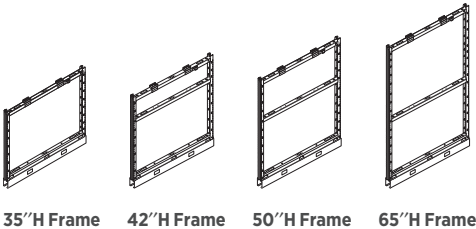

OPEN BASE PANEL FRAME

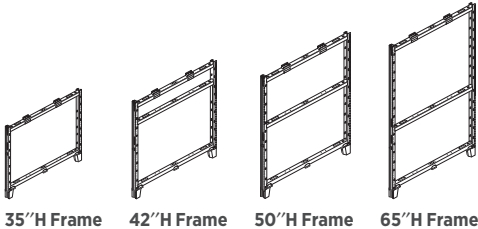

STACKING FRAMES

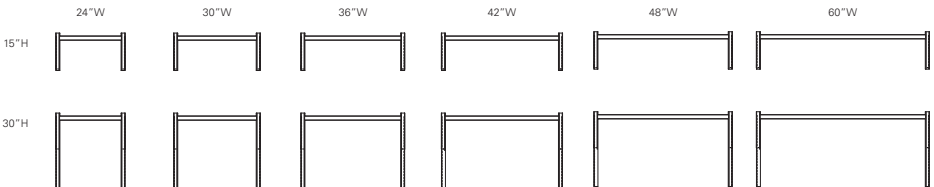
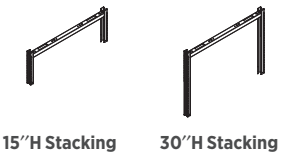

Reminder: Panel frame top caps must be ordered separately. Please refer to page 417. Do not specify top caps when putting frameless glass on top of the panel frame or when using a countertop worksurface.

ABOUND[®] FRAMES OVERVIEW

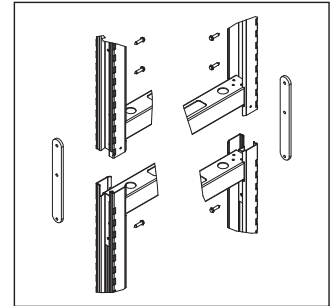
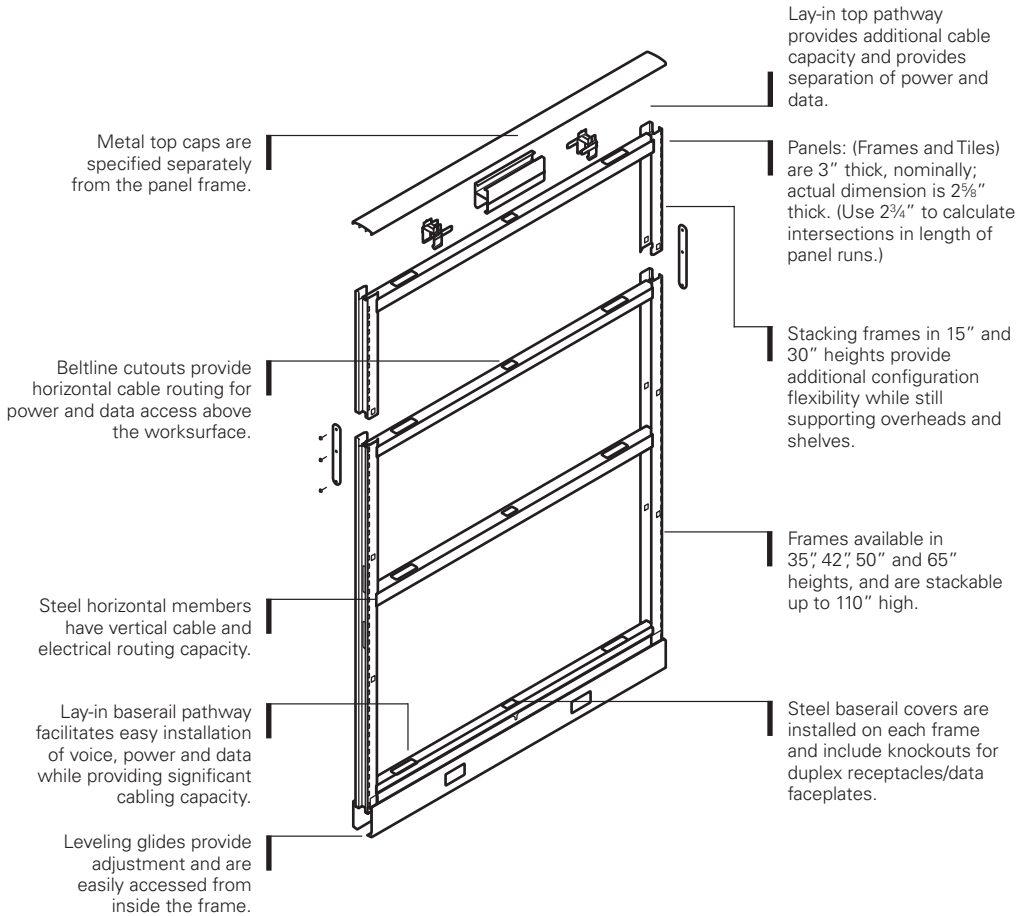

Stacking connection provides a solid metal-to-metal connection, allowing the stacking frame to accept hang-on components, per configuration guidelines.

Construction and Features

Specifications—formed, steel vertical members, with tubular steel horizontal members are welded into a sturdy, structural panel frame. Panel frames are shipped with base pathway covers installed.

Tiles, Panel Top Caps, and Segment Bars are ordered separately.

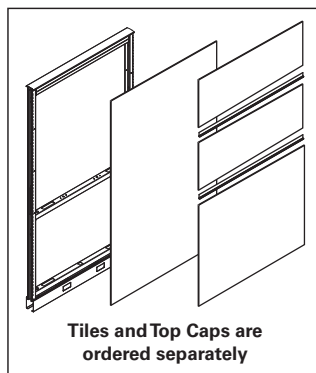

Additional design and specification information available at hon.com.

ABOUND[®] FRAMES OVERVIEW

FRAME DIMENSIONS (ACTUAL)

Depth: 2 $\frac{5}{8}$ " (use 2 $\frac{3}{4}$ " to calculate intersections in length of panel run)

Widths: 24", 30", 36", 42", 48", 60"

Heights*: Painted trim: 34 $\frac{1}{2}$ ", 42", 49 $\frac{1}{2}$ ", 64 $\frac{1}{2}$ "

Stacking Frames: 15"H, 30"H

*with levelers fully retracted

Stacking frames can be added to the top of any 35"H, 50"H or 65"H frame. Adding stacking frames to 42"H frames is not recommended due to inconsistencies in segmentation. 15"H and 30"H stacking frames can be used to add up to 45" of additional height to a standard frame. Do not combine differing frame widths in a single stack.

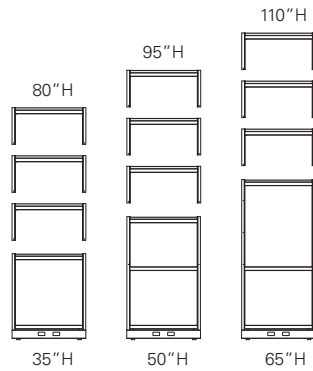

NOTE: When stacking on 42 $\frac{1}{2}$ "H frames, panel slots will be off by $\frac{1}{2}$ " compared to any other height panel. When stacking on 42 $\frac{1}{2}$ "H frames, hanging accessories will be $\frac{1}{2}$ " off in height compared to accessories hanging on panels at any height other than 42 $\frac{1}{2}$ "H.

BUILDING HORIZONTALLY WITH ABOUND FRAMES

Important planning guidelines: For adequate stability, one of two methods of stabilization must be adhered to:

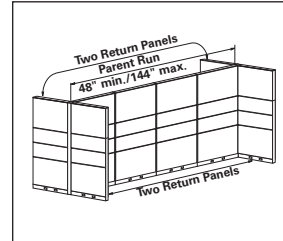

Method 1—Opposing returns:

A parent run must be a minimum of 48" and a maximum of 144" between return panels. The parent run must have a minimum of two return panels running in opposing directions on each end of run.

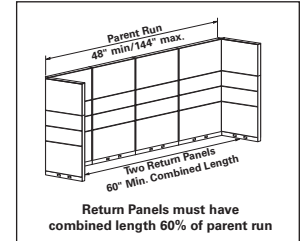

Method 2—Single-sided

Spine Length:	90 degree connector	120 degree connector
48"-108"	72" total	84" total
110"-132"	84" total	96" total
134"-144"	96" total	108" total

ABOUND[®] FRAMES OVERVIEW

INTERSECTING CONNECTIONS

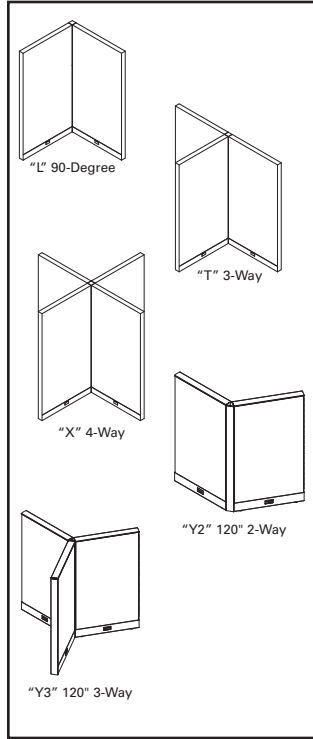

“L”, “T”, “X”, “Y2” and “Y3” connector kits are used when connecting frames at intersecting runs. For “L”, “T” and “X” connector kits, add $2\frac{3}{4}$ ” to the total length of the panel run for each intersection, whether located in the middle or at the end of the run.

Wall starter kits provide a means to affix a panel run to a permanent building wall. Kit adds $1\frac{1}{2}$ ” to length of panel run.

Segment bars — horizontal cross members required between tile segments. Must be specified on each side of frame. One Segment Bar is needed for each reveal between tiles.

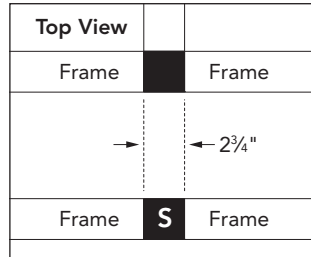
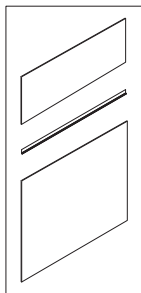

Extended straight connector kit “S” can be used to keep continuous runs dimensionally consistent with opposing panel runs which incorporate “T” or “X” intersections. (Add $2\frac{3}{4}$ ” to the length of the run for every extended straight connector used.)

IN-LINE CONNECTIONS

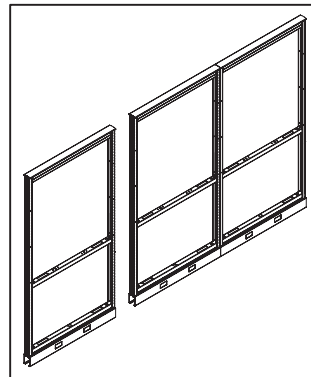

Direct connections between same height frames in a continuous run are accomplished with provided hardware. There is no incremental increase in dimension along the run.

END OF RUN

Finished end trim must be specified for the unconnected sides of panel frames. The Abound end trim adds $\frac{3}{8}$ ” to the length of the panel run. When adding a stacking frame, order finished end trim in the height that matches the stacking frame height. Move the end cap from the standard frame end trim to the stacking frame end trim.

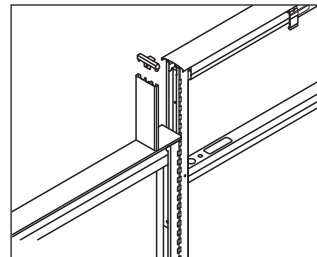

IN-LINE VARIABLE HEIGHT TRIM
In-line connections between different height panels require trim to cover the exposed frame of the taller panel. The bottom of the trim is contoured to match the profile of the frame top cap.

Multiple-height connections are accomplished by combining standard height panel connectors (35”H, 42”H, 50”H and 65”H) with shorter connectors (7”H, 15”H, 22”H and 30”H). Start from the bottom-up — select the standard connector that corresponds to the height and connection type of the tallest panel, then use the shorter connectors for variable height and connector top cap trim. (See examples.)

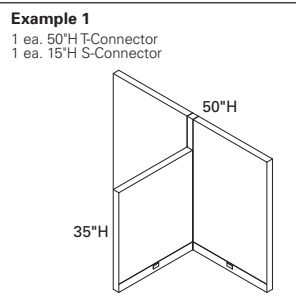

In variable height “T” connections — as shown above — you would use the connectors as indicated.

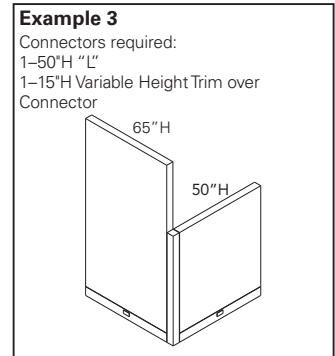
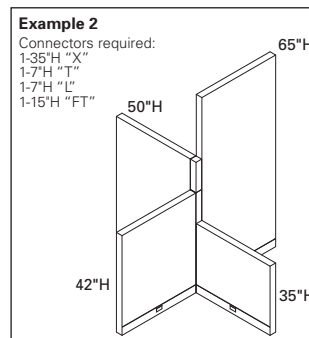

Example above represents Abound variable height “L” for 65” to 50” connection over connector.

VARIABLE HEIGHT CONNECTION TRIM

L, X and T connections between different height panels require trim to cover the exposed frame of the taller panel. The bottom of the trim is flat to match the profile of the Universal Connector top cap. Models are designated as “Variable Height Finished End over Connector Trim”. For variable height connections in a Y configuration, contact the HON Product Solutions group.

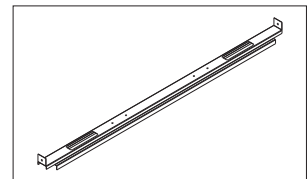

OPTIONAL STIFFENER SUPPORT

Stiffener supports can be used to provide additional rigidity to a panel when fabric tiles are on both sides of the frame. May also be used for routing power/data at non-standard heights.

ABOUND[®] CONNECTOR OVERVIEW

CONNECTOR KITS — ABOUND

- “L” 90° Connector Kit
- “T” 3-way Connector Kit
- “X” 4-way Connector Kit
- “S” “S” Extended Straight Connector Kit
- “Y2” 2-way 120° Connector Kit
- “Y3” 3-way 120° Connector Kit
- “W” Wall Starter Kit
- “F” End Trim Kit
- “V” Variable Height Finished End
- “FT” Variable Height Finished End over Connector

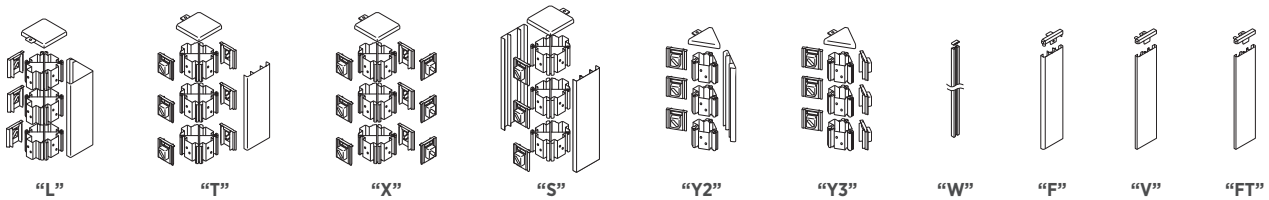

- Abound Connector Kits include universal connector block(s), bracket clips and painted metal trim.
- The universal connector block can be used for an L, T, X, or Extended Straight connections, simplifying staging and installation at the project site as well as future reconfigurations.
- Bracket clips are attached to the connector blocks as needed based upon connection type.
- While the connectors themselves are universal, Abound connector kits must be specified by connection type (X, L, T, S, 120 degree) in order to receive the correct type of trim.

ABOUND[®] TILE OVERVIEW

About tiles come in a variety of styles.

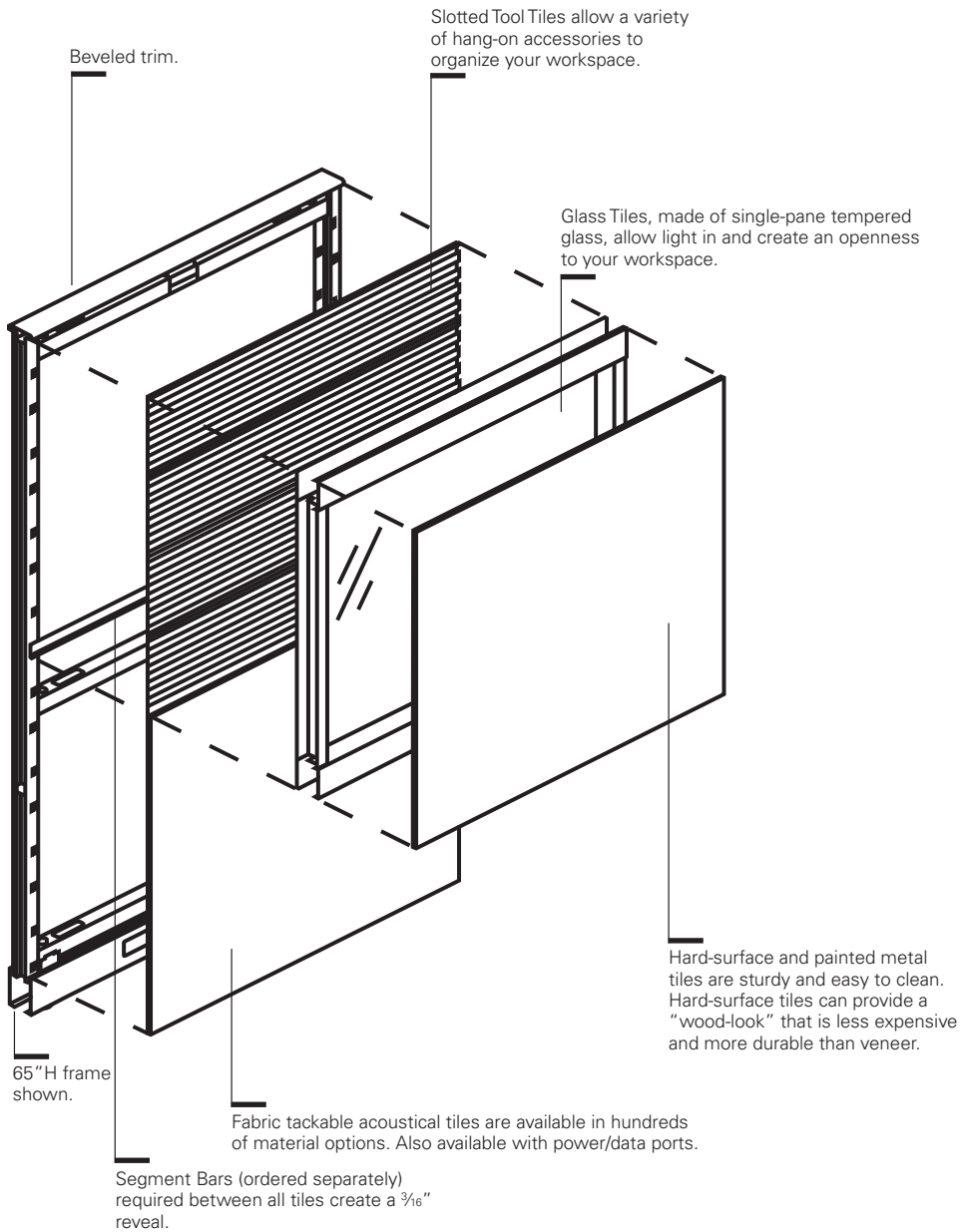

*Aesthetics of opposing tile surface and/or frame interior should be considered when selecting light-colored sheer materials.

ABOUT® SPECIFYING/DESIGN GUIDE

Tile Heights

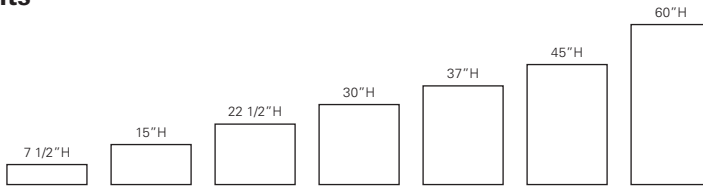

Monolithic tiles are 5" shorter than frame heights to account for top trim and base raceway.

Typical Tile Height Configurations

Segment bars are required between any two tiles — order separately based on tile configuration on each side of frame. Note: Most CAD specification programs will calculate quantity of segment bars required.

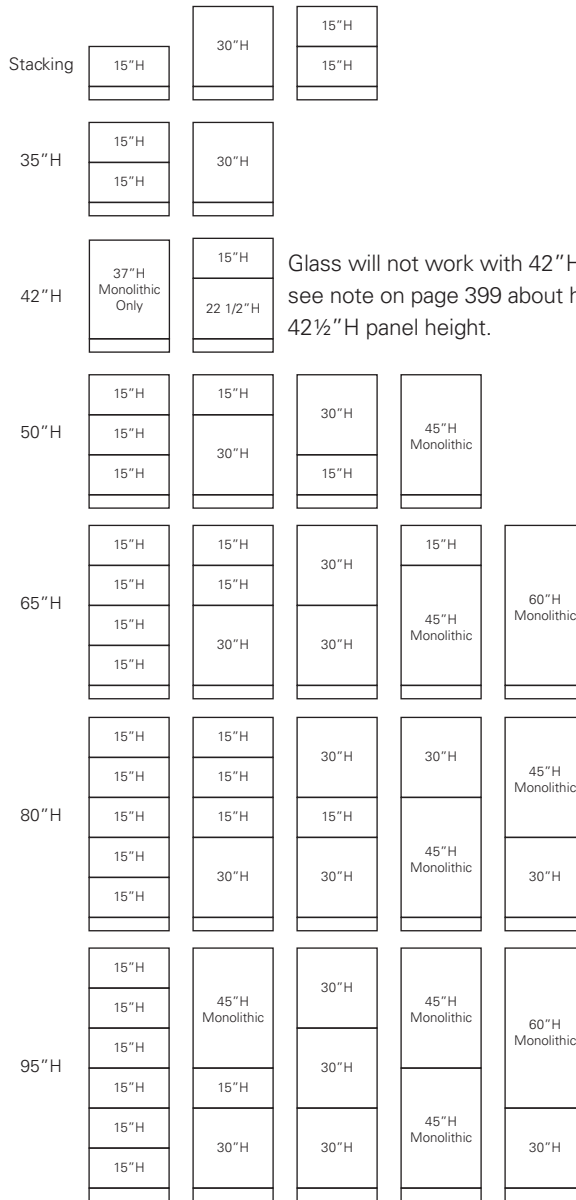

Glass will not work with 42"H frames. Please see note on page 399 about hanging on 42 1/2"H panel height.

*Additional tile combinations to those shown above are possible; heights above 65" require stacking frames - maximum height is 110."

To calculate the total height of tiles(s) required, deduct 5" (height of base/top trim) from the total nominal panel height.

EXAMPLE: 65"H Frame takes 2 30"H tiles. $65 - 5 = 2 \times 30$ or $45 + 15$

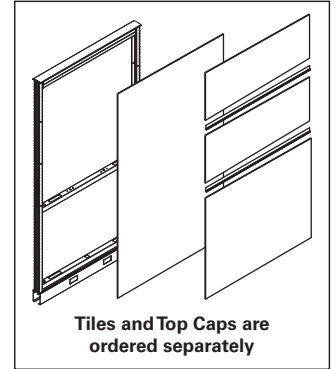

Tiles can be ordered in the size that matches the frame height plus the stacker height.

EXAMPLE: If you are using a 35"H frame plus a 30"H stacker, you can order 2 - 30"H tiles or 1 - 60"H tile.

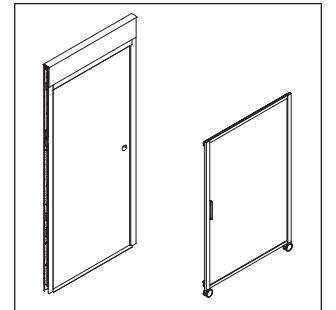

Door panels include frame, 42"W door, hinges and attaching hardware. Two 7 1/2"H fabric tiles for the top of the door frame are required and ordered separately (HRVDO742T).

Sliding doors are available in 50", 65", and 80"H models and can mount to 30", 36", 42", and 48"W panels. The doors provide a 36"W opening and are 42"W, nominally. The doors ship non-handed. A Mounting Bracket Kit must be ordered for each door corresponding to the mounting panel's width (30", 36", 42", or 48"W).

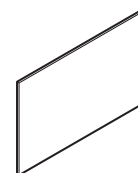

Hard-surface Tiles include tile and Custom Bracket Kit.

ABOUND[®] SPECIFYING/DESIGN GUIDE

WORKSTATIONS

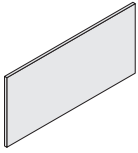

Fabric Tackable Acoustical Tile

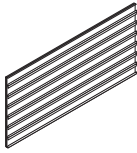

Slotted Tool Tile

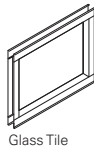

Glass Tile

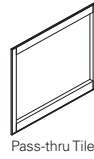

Pass-thru Tile

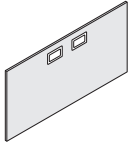

Fabric Tackable Acoustical Ported Tile

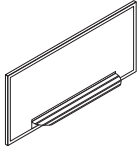

Markerboard Tile

*Markerboard tray ordered separately

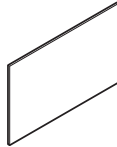

Hard-surface Tiles

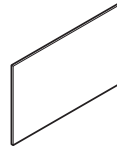

Painted Metal Tile

Tiles — Tackable Acoustical, Tackable Acoustical/Ported

	24"W	30"W	36"W	42"W	48"W	60"W
7 1/2"H						
15"H						
22 1/2"H						
30"H						
37"H						
45"H						
60"H						

Glass Tile Kits, Markerboard, Painted Metal Tiles

	24"W	30"W	36"W	42"W	48"W	60"W
15"H						
30"H						

Pass-thru Tiles

	24"W	30"W	36"W	42"W	48"W	60"W
30"H						

Slotted Tool Tile

	24"W	30"W	36"W	42"W	48"W	60"W
15"H						

Hard-surface Tiles

	24"W	30"W	36"W	42"W	48"W	60"W
15"H						
30"H						
37"H						

TILES

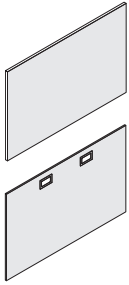

Tackable Acoustical Fabric Tiles

- Tiles do not include segment bars — order separately.

Port Tiles

- Receptacle openings with blank covers (1 in 24"W tiles; 2 in wider tiles). Located 30" above bottom of base raceway and 10½" from the edge of the frame.
- Tiles do not include segment bars — order separately.
- 30"H ported tiles on 35"H frame will need additional stiffener support.
- Ported tiles should only be used to accommodate beltline height. If a port is needed at an alternate height, please submit a special request.
- Tiles cannot be flipped to move data ports.
- Duplex brackets must be specified for ported tiles.

Painted Metal

- Tiles do not include segment bars — order separately.
- Painted steel construction.
- 15"H and 30"H tiles are non-dedicated and can be used in any tile position.
- Tiles can accept magnets.

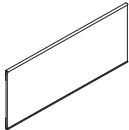

Tool Tiles

- Tiles do not include segment bars — order separately.
- Sturdy aluminum extrusion with steel support construction.
- Powder coated for durable finish.
- Work tools available.
- Use in place of standard 15"H tiles.
- Cannot be used in the bottom location of a panel frame or on wall track.
- Each tool tile has a suggested weight capacity of 80 lbs. of paper management accessories.

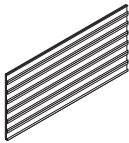

Pass-Thru Tiles

- Pass-thru opening is 22½"H.
- Used as 30"H tile.
- Must order quantity of one 7½"H tile if finishing one side and quantity of two 7½"H tiles if finishing both sides.
- No segment bar needed above tile.
- Built into trim pieces.

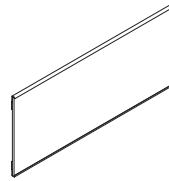
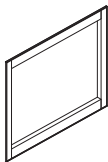

Hard Surface

- High Pressure Laminate — available in standard laminate colors.
- Tiles do not ship with segment bars — order separately.
- Tiles come completely assembled and attach with custom tile bracket kit. Specify paint color.
- 15"H, 30"H, and 37"H tiles are non-dedicated and can be used in any tile position.
- Vertical grain on all tile sizes.

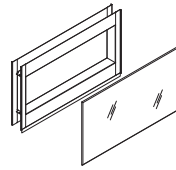

Glass Tiles

- Clear and frosted glass.
- Clear glass is writeable with dry erase marker — frosted glass is not.
- Tempered safety glass encased within a frame.
- Single-pane construction, glass is flush on one side.
- Glass opening is 4" less than nominal heights and widths.
- Cannot be used in top tile position of a 42½"H panel frame or any frame with integrated power pole.
- Cannot be used at the bottom or beltline location of panel frame.
- 30"H glass tiles can only be placed in top position of 65"H frames or only in 30"H stacking frame. Segment bar needs to be ordered.

Marker Board Tiles

- White marker board tile; painted steel surface.
- Accepts magnetic accessories.
- 15"W magnetically attachable tray is natural aluminum color — order separately.
- 15"H and 30"H tiles are non-dedicated and can be used in any tile position.

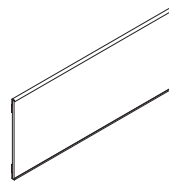

Gallery Panels

- 1½" thick laminate panels used as wing or end of run panels only.
- Available in 35"H, 42½"H, and 50"H options.
- Options available to include frameless glass.
- Gallery Panel connectors purchased separately.

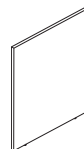

Custom Material Bracket Kit

- Do not ship with segment bars — order separately.
- Used with Customer's Own Material — thickness is ¼".
- Contact HON for insert dimensions.

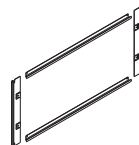

ABOUND® GALLERY PANELS OVERVIEW

GALLERY PANELS

Abound® Gallery Panels are an affordable, sleek way to incorporate laminate wing and end of run panels where power is not needed. The simplistic design provides a great new way to add woodgrains or solid laminate finishes to your workstation allowing for greater customization and value engineering.

BASIC CHARACTERISTICS

- Available in L-, T-, and Mid-configurations.
- Made of 1 1/8" board with high-pressure laminate.
- Use 1/8" thickness for space planning.
- Can be specified with matching or contrasting edge colors.
- Available in woodgrain and solid laminates.
- Woodgrain laminates can be specified with vertical grain on panels from 24" to 60"W.
- Horizontal grain available on all panel sizes.
- Gallery Panels offer 2 1/2" leveling capacity.
- Overall heights line up with adjacent panel.
- Available with and without integrated glass options (specified separately).
- Gallery Panels for use with glass have separate model numbers.
- All configurations are non-handed and secured using hidden fasteners.
- Standard Gallery Panels cannot connect to each other, you must use Gallery-to-Gallery Panels for connections.
- Additional support is required after every 60" in Gallery Panel width (i.e., storage or workstation tie-in).
- Gallery Panel widths are true to size.
- Please adhere to all standard systems specification guides.

GALLERY PANEL OFFERING

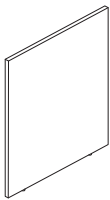

Wing End of Run
42"H, 50"H x 27", 33", 39", 45", 51", 63"W
Wing Middle of Run
42"H, 50"H x 24", 30", 36", 42", 48", 60"W
Spanning End of Run
42"H, 50"H x 51", 63", 75"W

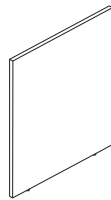

Wing End of Run, Glass
42"H, 50"H x 27", 33", 39", 45", 51", 63"W
Wing Middle, Glass
42"H, 50"H x 24", 30", 36", 42", 48", 60"W
Spanning End of Run, Glass
42"H, 50"H x 51", 63", 75"W

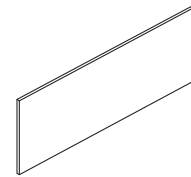

Wing End of Run, Glass
7 1/2"H x 27", 33", 39", 45", 51", 63"W
Wing Middle, Glass
7 1/2"H x 24", 30", 36", 42", 48", 60"W
Spanning End of Run, Glass
7 1/2"H x 51", 63", 75"W

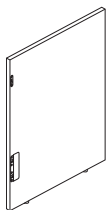

Gallery-to-Gallery, L-Connection
35"H, 42"H, 50"H x 18", 24", 30", 36", 42", 48", 60"W
Gallery-to-Gallery, L-Connection, Glass
35"H, 42"H, 50"H x 18", 24", 30", 36", 42", 48", 60"W

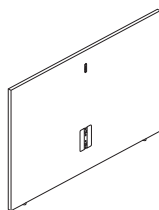

Gallery-to-Gallery, T-Connection
35"H, 42"H, 50"H x 18", 24", 30", 36", 42", 48", 60"W
Gallery-to-Gallery, T-Connection, Glass
35"H, 42"H, 50"H x 18", 24", 30", 36", 42", 48", 60"W

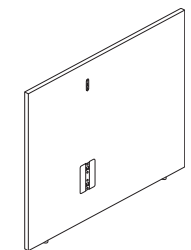

Gallery-to-Gallery, Non-Symmetrical Connection
35"H, 42"H, 50"H x 18", 24", 30"W
Gallery-to-Gallery, Non-Symmetrical, Glass
35"H, 42"H, 50"H x 18", 24", 30"W

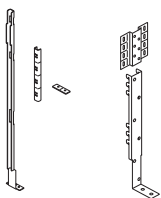

Gallery Panel Connectors
Spanning End of Run, L Connectors, and Wing Middle Brackets



Gallery Connector ("Block and Trim" Kit)
For 35"-65"H Panels

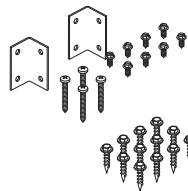

Gallery to Metal/Laminate Kits

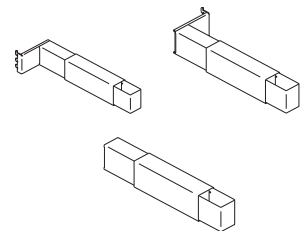

Height Adjustable Tie-In Brackets

ABOUND[®] GALLERY PANELS OVERVIEW

GALLERY PANELS DIMENSIONS

Gallery Panel Widths

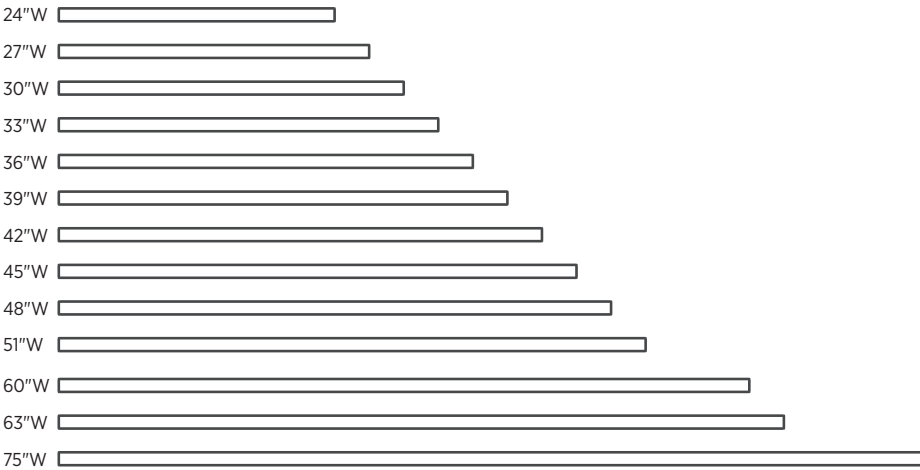

Gallery Panel Heights

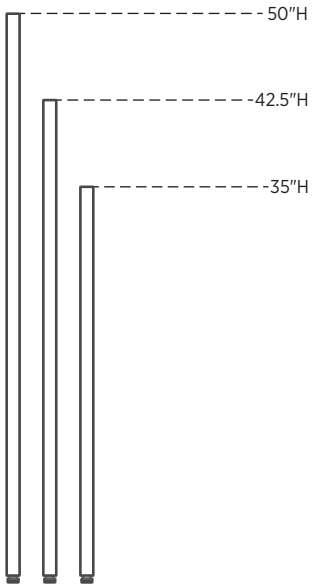

WORKING WITH INTEGRATED GLASS

- Gallery Panels for use with glass offer a routed top edge.
- Glass mounts directly into the Gallery Panel route via a gasket.
- The routing is inset 1½" from each end of the panel on standard Gallery Panels.
- Total glass width will be 3" narrower than the Gallery Panel.
- Glass height is available in 7½"H.
- Glass is available on all Gallery Panel widths.
- Specify glass models separate from Gallery Panel models.
- Routing is inset ½" on L and T Gallery Panels.

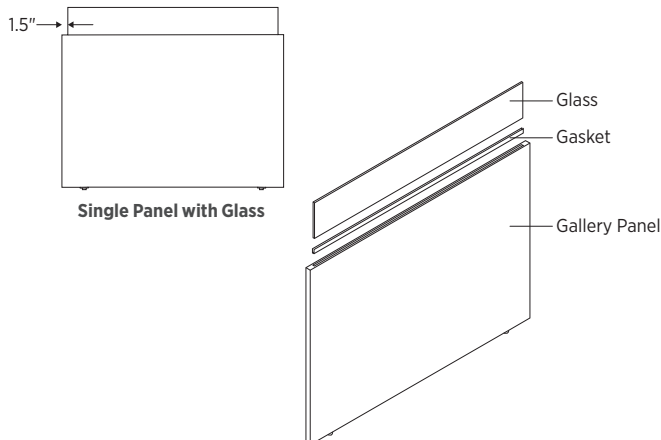

ABOUND® GALLERY PANELS OVERVIEW

T-CONFIGURATION

- Provides privacy to one or both ends of the Abound® system in a dual-sided application.
- All T-configurations connect using HRVCE connector kit.
- When the system panel is higher than the Gallery Panel, a variable height system's trim must be specified to finish off the exposed frame.
- T-configuration can be used for off-modular planning. The HRVCE connector kit location must be field measured.
- Accommodate for 2⁵/₈" frame thickness when planning with Abound® panel system.

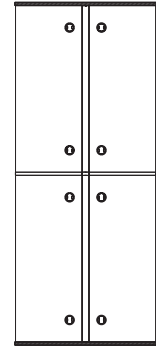
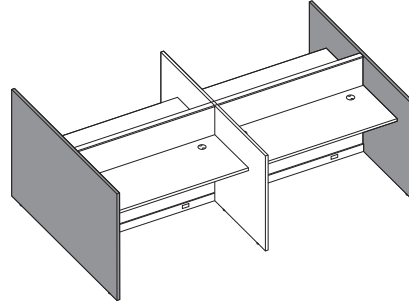

L-CONFIGURATION

- Provides privacy to one or both ends of the system in a single-sided application.
- L-configuration caps over the system panel.
- Due to the thickness of the Abound® panel L-configuration overhangs by approximately 3/16" on both sides.
- Accommodate for 2⁵/₈" frame thickness planning with Abound® panel system.
- All L-configuration Gallery Panels require the connector kit HRVCE to attach to the parent run.
- When the system panel is higher than the Gallery Panel, the variable height system's trim must be specified to finish off exposed frame.

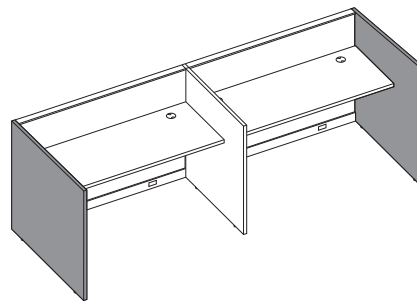

MID-CONFIGURATION (SINGLE-SIDED OR DUAL-SIDED)

- Mid-configuration panel does not overlap parent system panel.
- When specifying mid-configuration panels, one Gallery Panel "block and trim" kit (HRVCXXGP) is required to space the system panels out 1¹/₈". Kits include: Connector blocks, vertical trim, and a top cap.
- "Block and trim" models must match the height of the parent run.
- Specify one mid-connector kit (HRVCM) per Gallery Panel to attach to parent run. Gallery Panel and mid-connector kit attach over "block and trim" kit. Dual-sided application requires two connector kit models.
- When using a mid-configuration Gallery Panel, both panel frames in the spine must be of equal height.
- Mid-configuration Gallery Panel may exceed the height of the parent run by a maximum of 15".
- Trims can be painted to match the system panel trims.

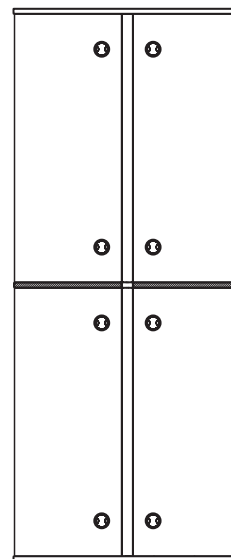

Dual-Sided Configuration

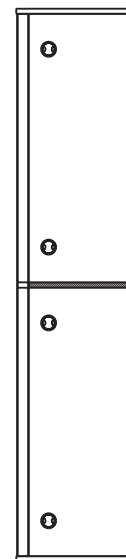

Single-Sided Configuration

ABOUT® GALLERY PANELS OVERVIEW

STORAGE AND WORKSURFACE CONNECTORS

- Use HRVGLSK to connect to laminate storage or HRVGMSK for metal storage.
- To connect to worksurfaces use HSTB2W1 bracket when used in perpendicular to parent run or use standard systems cantilever brackets when used in parallel to parent run in panel systems.

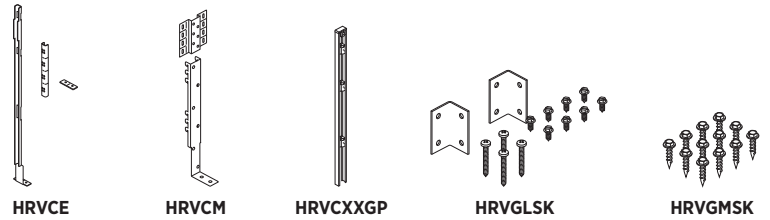

PANEL SYSTEMS

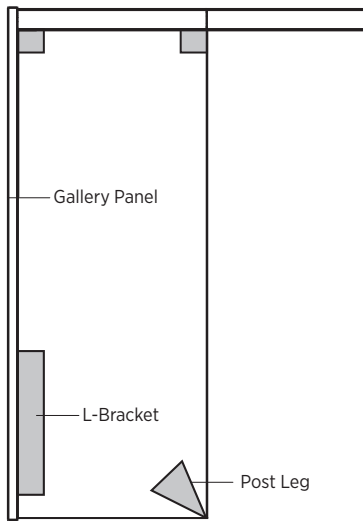

Perpendicular panel system with L-bracket (HSTB2W1) and post leg.

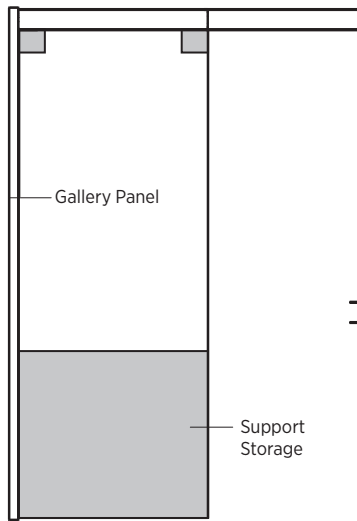

Perpendicular panel system with storage support.

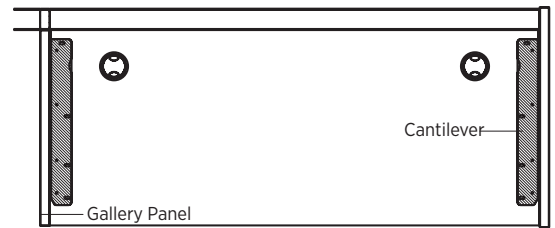

Panel system with cantilever support.

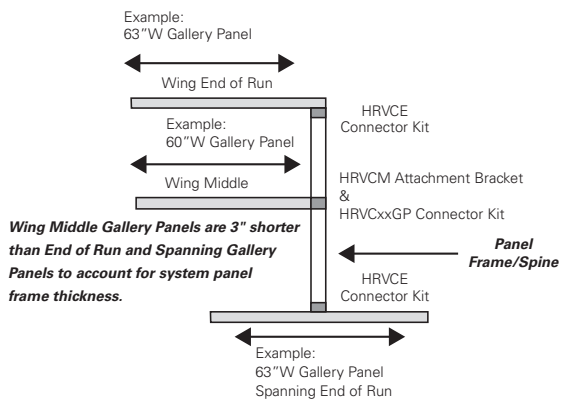

ABOUND[®] GALLERY PANELS OVERVIEW

GALLERY-TO-GALLERY PANELS

- Gallery-to-Gallery Panels connect to other Gallery Panels and are available in L-, T-, and Non-symmetrical T-configurations.
- When specifying Gallery-to-Gallery Panels, the installation template HRVGTGG is required. The recommendation is one template for every 30 panels.
- Gallery-to-Gallery Panels must be of equal or lower height than the Standard Gallery Panel attached. The Gallery-to-Gallery Panel cannot be taller than the adjacent panel. If this is needed, please reach out to Tailored Solutions for a custom solution.
- Made of 1 $\frac{1}{8}$ " board with HPL laminate.
- Can be specified with matching or contrasting edge.
- Edgeband is 2mm ABS.
- Available in woodgrain and solid laminates.
- Woodgrain laminates can be specified with vertical grain up to 48"W.
- Gallery-to-Gallery Panel widths are available in 18", 24", 30", 36", 42", 48", 60"W, and 72" (T).
- Gallery Panels offer 2 $\frac{1}{2}$ " leveling capability.
- Overall heights line up with adjacent panel.
- Gallery-to-Gallery Panels cap over Standard Gallery Panels and are oversized by 1 $\frac{1}{8}$ " to maintain true interior dimensions.
- Available with or without the integrated glass option.
- Glass is specified separately. Use mid-connection glass.
- Gallery Panels for use with glass have separate model numbers.
- Gallery-to-Gallery Panels are secured with an inset flat bracket under a painted metal cover. Paint color is specifiable to blend in with laminate choice.
- L-panels are handed.
- Non-symmetrical T-panels vary in size on either side of the adjacent panel.
- Please adhere to all standard systems specification guidelines.
- Additional support is required after every 60" in Gallery Panel width (i.e., a storage or worksurface tie-in).

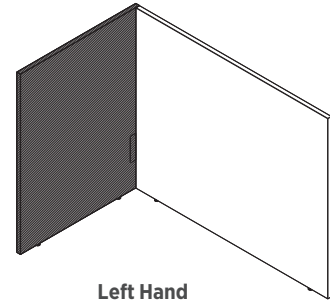

Left Hand

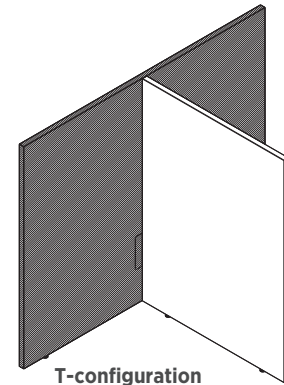

T-configuration

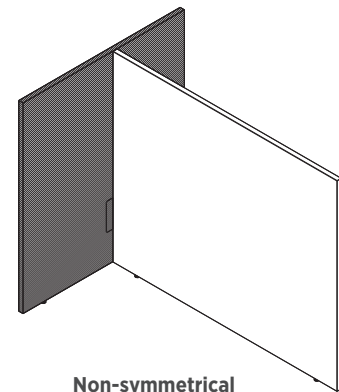

Non-symmetrical

ABOUT® GALLERY PANELS OVERVIEW

GALLERY-TO-GALLERY FREESTANDING SCREENS

Freestanding screens can be created using Standard Gallery Panels and Gallery-to-Gallery Panels. All Gallery Panel heights are allowed. Increase minimum return length by 3" (or next largest width) of panel for every 7½" variation in panel height.

Freestanding L-Screens

Parent	Minimum Return*
30"-36"	30"
>42"-60"	36"
60"-75"	42"

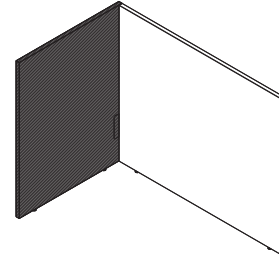
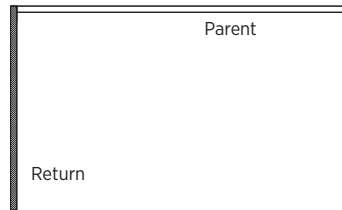

* 18"-24" not valid

Freestanding U-Screens

Parent	Minimum Return*
24"-48"	24"
60"-75"	30"

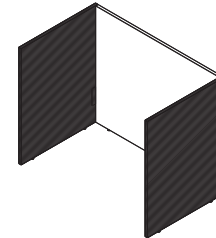
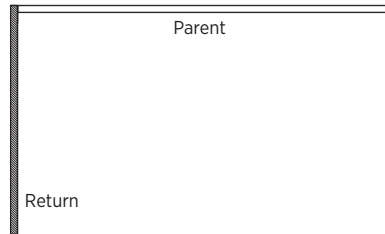

* 18"-24" not valid

Freestanding T-Screens

Parent	Minimum Return*
30"-75"	30"
36"-75"	36"
42"-72"	42"

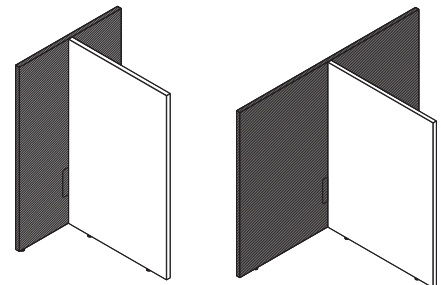

* 18"-24" not valid

Freestanding H-Screens

Freestanding T (Dual-Sided)	
Parent	Minimum Return
30"-60"	18"

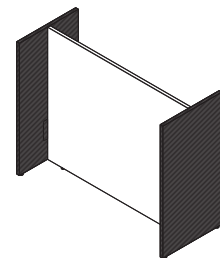
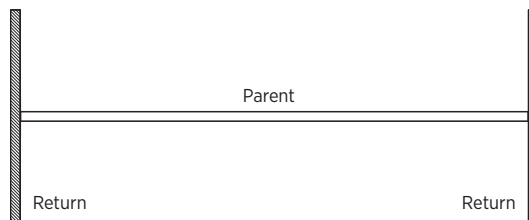

NOTES: Increase minimum return length by 3" or next largest width of panel for every 7½" variation in panel height.

ABOUND® SYSTEMS

Electrical and Data

About String-in Capacity

Openings in frame sides permit electrical data and communication cables to be run between frames in Abound. Using tackable acoustical tiles, the beltline pathway accommodates up to 62 cables (.25" dia) or 46 cables with electrical components installed.

DO NOT run electrical equipment or extension cords through cable openings in frame sides. Use beltline or base-mounted electrical system for all electrical supply.

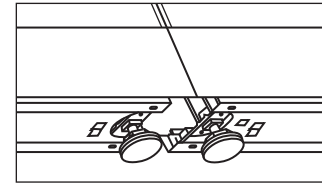
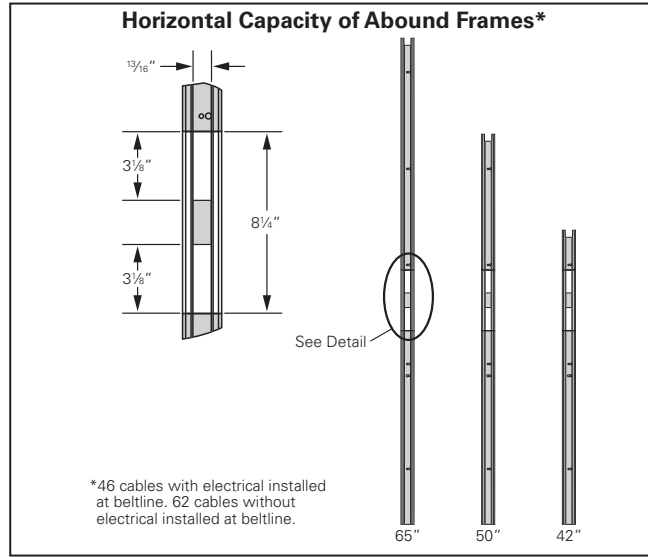

Cables can enter/exit panel through underside of base pathway at juncture between frames. Openings are sized as follows (in sq. in.):

Straight connection	6.0
"S" Extended Straight Connection	10.0
"L" 90° Connection	8.9
"T" Connection	15.9
"X" Connection	17.9
"Y" Connection	—

When leveling glides are fully retracted, panel-to-floor clearance is 7/16". This may affect the volume of cabling that can be fed into the frame from the bottom of the pathway.

Vertical Capacity

Vertical Capacity Through Panel Frames

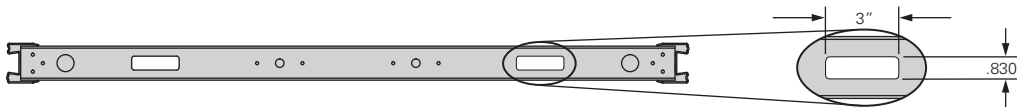

- A 60% fill ratio is achievable; however, when electrical components are installed in the beltline area, cabling capacity through the beltline area will be limited to approximately 45% fill ratio.

	Panel Width	Qty of .25" Cables at 45% Fill Ratio	Qty of .25" Cables at 60% Fill Ratio	Total Space (sq. in.)
Abound	24" - 60"W	48	64	5.26



ABOUND® Panel Frames

	DESCRIPTION	MODEL	SHIP WEIGHT	CUBE	LIST PRICE BY PAINT GRADE	
					P1	P2
	35" H Panel Frame					
	35" H x 24" W	HRVF3524P	8.0	1.7	\$234	\$270
	35" H x 30" W	HRVF3530P	11.0	2.1	\$240	\$276
	35" H x 36" W	HRVF3536P	13.0	2.4	\$245	\$281
	35" H x 42" W	HRVF3542P	16.0	2.8	\$255	\$291
	35" H x 48" W	HRVF3548P	18.0	3.2	\$270	\$306
	42" H Panel Frame					
	42" H x 24" W	HRVF4224P	11.0	2.0	\$240	\$276
	42" H x 30" W	HRVF4230P	14.0	2.4	\$250	\$286
	42" H x 36" W	HRVF4236P	17.0	2.9	\$255	\$291
	42" H x 42" W	HRVF4242P	19.0	3.4	\$271	\$307
	42" H x 48" W	HRVF4248P	22.0	3.8	\$284	\$320
	50" H Panel Frame					
	50" H x 24" W	HRVF5024P	14.0	2.3	\$257	\$293
	50" H x 30" W	HRVF5030P	17.0	2.9	\$270	\$306
	50" H x 36" W	HRVF5036P	20.0	3.4	\$270	\$306
	50" H x 42" W	HRVF5042P	24.0	4.0	\$287	\$323
	50" H x 48" W	HRVF5048P	27.0	4.5	\$293	\$329
	65" H Panel Frame					
	65" H x 24" W	HRVF6524P	17.0	3.0	\$278	\$314
	65" H x 30" W	HRVF6530P	22.0	3.7	\$284	\$320
	65" H x 36" W	HRVF6536P	25.0	4.4	\$289	\$325
	65" H x 42" W	HRVF6542P	30.0	5.1	\$300	\$336
	65" H x 48" W	HRVF6548P	35.0	5.8	\$318	\$354
	Panel Top Cap					
	24" W	HRVTC24	1.6	0.3	\$35	\$55
	30" W	HRVTC30	1.8	0.3	\$45	\$65
	36" W	HRVTC36	2.0	0.3	\$58	\$78
	42" W	HRVTC42	2.2	0.3	\$61	\$81
	48" W	HRVTC48	3.4	0.4	\$67	\$87
	54" W	HRVTC54	3.7	0.5	\$82	\$102
	60" W	HRVTC60	3.9	0.6	\$82	\$102
	66" W	HRVTC66	4.0	0.6	\$98	\$118
	72" W	HRVTC72	5.3	0.8	\$102	\$122
	78" W	HRVTC78	6.5	0.8	\$106	\$126
84" W	HRVTC84	6.7	0.9	\$115	\$135	
90" W	HRVTC90	7.0	0.9	\$121	\$141	
96" W	HRVTC96	7.2	0.9	\$127	\$147	

ⓘ When stacking on 42½" H frames, panel slots will be off by ½" compared to any other height panel.

ⓘ When stacking on 42½" H frames, hanging accessories will be ½" off in height compared to accessories hanging on panels at any height other than 42½" H.

NOTES: Top caps can span more than one panel in an in-line connection.

ⓘ Top cap models are to be used on Abound® frames only.

NOTES:

- Includes frame, baserail covers, attaching hardware and bottom segment bar.
 - Frames, top caps and tiles are ordered and shipped separately.
 - Frames are 2½" thick with a 5" H baserail.
 - Frames are standard with two adjustable leveling glides which can be adjusted from the bottom of the glide or from the interior of frame.
 - Two wire and data management openings standard per raceway, 24" panel has one opening.
 - Lay-in wire management available in base. Horizontal cable routing available at beltline.
 - Lay-in top pathway provides additional data cabling capacity.
 - For worksurfaces that can be used with both Abound® and Accelerate® systems, see pages 581-591.
- ⓘ Panels should not be used in unsupported applications or take the place of permanent walls. Panels are intended to be supported with floor supports and/or storage or tied in with worksurfaces. Refer to Specifying and Design Guide pages.

HOW TO SPECIFY

<p>Select Model Number</p> <p>HRVF3524P</p>	<p>Select Trim Color</p> <p>See page 395</p> <p>T4</p>
---	--

ABOUND® Open Base Panel Frames

GSA SIN 33721



Icon Legend on page 19

WORKSTATIONS

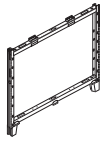

DESCRIPTION

35" H Open Base Panel Frame

DESCRIPTION	MODEL	SHIP WEIGHT	CUBE	LIST PRICE BY PAINT GRADE	
				P1	P2
35" H x 24" W	HRFF3524P	8	1.7	\$234	\$270
35" H x 30" W	HRFF3530P	11	2.1	\$240	\$276
35" H x 36" W	HRFF3536P	13	2.4	\$245	\$281
35" H x 42" W	HRFF3542P	16	2.8	\$255	\$291
35" H x 48" W	HRFF3548P	18	3.2	\$270	\$306
35" H x 60" W	HRFF3560P	23	4.0	\$299	\$335

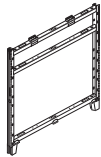

42" H Open Base Panel Frame

42" H x 24" W	HRFF4224P	11	2.0	\$240	\$276
42" H x 30" W	HRFF4230P	14	2.4	\$250	\$286
42" H x 36" W	HRFF4236P	17	2.9	\$255	\$291
42" H x 42" W	HRFF4242P	19	3.4	\$271	\$307
42" H x 48" W	HRFF4248P	22	3.8	\$284	\$320
42" H x 60" W	HRFF4260P	28	4.7	\$316	\$352

ⓘ When stacking on 42½" H frames, panel slots will be off by ½" compared to any other height panel.

ⓘ When stacking on 42½" H frames, hanging accessories will be ½" off in height compared to accessories hanging on panels at any height other than 42½" H.

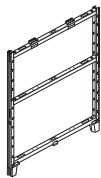

50" H Open Base Panel Frame

50" H x 24" W	HRFF5024P	14	2.3	\$257	\$293
50" H x 30" W	HRFF5030P	17	2.9	\$270	\$306
50" H x 36" W	HRFF5036P	20	3.4	\$270	\$306
50" H x 42" W	HRFF5042P	24	4.0	\$287	\$323
50" H x 48" W	HRFF5048P	27	4.5	\$293	\$329
50" H x 60" W	HRFF5060P	34	5.6	\$322	\$358

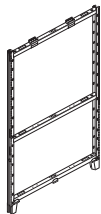

65" H Open Base Panel Frame

65" H x 24" W	HRFF6524P	17	3.0	\$278	\$314
65" H x 30" W	HRFF6530P	22	3.7	\$284	\$320
65" H x 36" W	HRFF6536P	25	4.4	\$289	\$325
65" H x 42" W	HRFF6542P	30	5.1	\$300	\$336
65" H x 48" W	HRFF6548P	35	5.8	\$318	\$354
65" H x 60" W	HRFF6560P	43	7.2	\$346	\$382

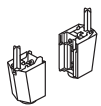

Raceway to Open Base Conversion Kit

HRVFFOOT	4	0.1	\$168	\$188
----------	---	-----	-------	-------

NOTES:

- Includes frame, attaching hardware and bottom segment bar.
- Tiles and top caps are ordered and shipped separately.
- Frames are 2⅝" thick with a 5" H open base.
- Frames are standard with two adjustable leveling glides which can be adjusted from the bottom of the glide.
- Horizontal cable routing available at beltline.
- Lay-in top pathway provides additional data cabling capacity.
- See page 417 for top cap options.
- For worksurfaces that can be used with Abound® and Accelerate® systems, see pages 581-591.



ⓘ Panels should not be used in unsupported applications or take the place of permanent walls. Panels are intended to be supported with floor supports and/or storage or tied in with worksurfaces. Refer to Specifying and Design Guide pages.

HOW TO SPECIFY

Select Model Number H R F F 3 5 2 4 P	Select Trim Color See page 395 T 4
---	---

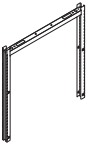

ABOUND® Stacking Panel Frames

	DESCRIPTION	MODEL	SHIP WEIGHT	CUBE	LIST PRICE
	15”H Stacking Panel Frame				
	15”H x 24”W	HRVF1524	8	0.8	\$218
	15”H x 30”W	HRVF1530	10	0.9	\$228
	15”H x 36”W	HRVF1536	12	1.1	\$234
	15”H x 42”W	HRVF1542	14	1.3	\$243
	15”H x 48”W	HRVF1548	16	1.5	\$245
	15”H x 60”W	HRVF1560	20	1.8	\$253
	30”H Stacking Panel Frame				
	30”H x 24”W	HRVF3024	10	1.4	\$230
	30”H x 30”W	HRVF3030	12	1.8	\$243
	30”H x 36”W	HRVF3036	14	2.1	\$251
	30”H x 42”W	HRVF3042	16	2.4	\$261
	30”H x 48”W	HRVF3048	18	2.8	\$265
	30”H x 60”W	HRVF3060	22	3.4	\$282
	Full Segment Bars				
	24”W	HRVFSB24	2	0.4	\$21
	30”W	HRVFSB30	2	0.4	\$21
	36”W	HRVFSB36	3	0.5	\$22
	42”W	HRVFSB42	3	0.5	\$23
	48”W	HRVFSB48	3	0.6	\$24
	60”W	HRVFSB60	4	0.7	\$25

❗ Must order one segment bar per panel reveal, per panel side.

NOTES:

- Frames, top caps and tiles are ordered and shipped separately.
- Includes attachment hardware.
- Stacking frames can be added to the top of any 35”H, 50” or 65”H frame.
- No paint selection necessary on stacking frames.
- Overhead storage units can be suspended from stacking frames. See pages 548-549.
- Segment Bars do not need to be specified for monolithic tiles, when only a single tile is attached to the frame.
- ❗ When stacking on 42½”H frames, panel slots will be off by ½” compared to any other height panel.
- ❗ When stacking on 42½”H frames, hanging accessories will be ½” off in height compared to accessories hanging on panels at any height other than 42½”H.
- ❗ Not designed to combine differing frame widths in a single stack.
- ❗ Stacking frames not designed to be used as a base frame.
- ❗ Segment bars available in Black only.
- ❗ Segment Bars are formed, steel cross members and are required between tiles and on each side of the frame.

HOW TO SPECIFY

Select
Model Number

H R V F 1 5 2 4

ABOUND® Stiffener Supports

GSA SIN 33721



Icon Legend on page 19

WORKSTATIONS



DESCRIPTION

Stiffener Support

24"W
30"W
36"W
42"W
48"W
60"W

MODEL

HRVSS24
HRVSS30
HRVSS36
HRVSS42
HRVSS48
HRVSS60

SHIP WEIGHT

1
1
4
4
4
4

CUBE

0.4
0.4
0.5
0.5
0.5
0.7

LIST PRICE

\$56
\$58
\$62
\$77
\$86
\$94

! Black only. No need to specify paint.

NOTES:

- Tile stiffener supports can be used to increase the stiffness of a panel and can also be used to mount power/data anywhere vertically on an Abound frame. Can only be used when there are fabric tiles on both sides of the frame.
- Self-drilling screws included.

! Black only. No need to specify paint.

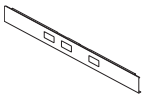

HRVBPLATE336

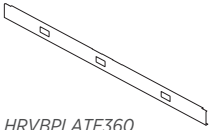

HRVBPLATE360

DESCRIPTION

Abound® Base Pathway Cover w/Additional Knockout

36"W
42"W
48"W
60"W

MODEL

HRVBPLATE336
HRVBPLATE342
HRVBPLATE348
HRVBPLATE360

SHIP WEIGHT

7 Ⓞ
8 Ⓞ
9 Ⓞ
11 Ⓞ

CUBE

0.4
0.4
0.4
0.5

LIST PRICE BY PAINT GRADE

P1

\$73
\$75
\$78
\$89

P2

\$83
\$85
\$88
\$99

NOTES: Specify paint, see page 395.

SPECIFYING EXAMPLE: HRVBPLATE336.T4

NOTES:

- ! Specify Pathways to match trim color.
- ! Standard raceways with two knockouts are standard on panels. If additional three knockout kickplate is ordered, the two port version can be saved or discarded.

HOW TO SPECIFY

Select
Model Number

Select
Paint Color

See page 395

HRVBPLATE336 .

T4



ABOUND® Panel Door



DESCRIPTION	MODEL	SHIP WEIGHT	CUBE	L1 LIST PRICE BY PAINT GRADE	
				P1	P2
Door Panel — Laminate 42"W x 95"H NOTES: Includes frame, 42"W door, hinges and attaching hardware. Lockset or Knob ordered separately. Best placement of a door is at an L, T, X connector or wall starter connector for rigidity. Use of spanning top caps at an in-line will also help add additional rigidity. ! Two HRVD0742T tiles for above the door must be ordered per each door ordered. See below. ! Top Cap must be ordered separately. See page 417 for top cap specification.	HRVD9542P	155	5.4	\$2251	\$2287

HOW TO SPECIFY

Select Model Number HRVD9542P	Select Trim Color See page 395 T4	Select Door Laminate L1 Woodgrain only See page 395 K2
---	--	--

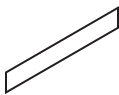

DESCRIPTION	MODEL	SHIP WEIGHT	CUBE	LIST PRICE BY FABRIC GRADE						
				A	B	C	D	E	F	G
Fabric Tiles for Door Panel 7½"H x 42"W ! Must be ordered with the Door Panel model above. ! Required for door installation. ! Two tiles must be ordered for installation. Tiles ship 1/pkg.	HRVD0742T	3	1.2	\$84	\$88	\$92	\$102	\$105	\$109	\$113

HOW TO SPECIFY

Select Model Number HRVD0742T	Select Fabric Color See pages 396-397 APN15
---	--



DESCRIPTION	MODEL	SHIP WEIGHT	CUBE	LIST PRICE
Lockset (Door Knob) Polished Brass, keyed on one side	HN899900	2.0	0.1	\$117



Door Lever Brushed Aluminum, keyed on one side	HN899910	2.0	0.1	\$324
--	-----------------	-----	-----	--------------



Carpet Grippers NOTES: Used with Glide Towers Shipped 12 per package No need to specify finish	HICG12	0.5	0.1	\$20
--	---------------	-----	-----	-------------

ABOUND[®] Sliding Door

GSA SIN 33721



Icon Legend on page 19

WORKSTATIONS



DESCRIPTION	MODEL	SHIP WEIGHT	CUBE	LIST PRICE BY PAINT GRADE	
				P1	P2
Abound Sliding Door					
50"H x 42"W	HH15042SD	28	5.5	\$2058	\$2094
65"H x 42"W	HH16542SD	38	7.1	\$2346	\$2382
80"H x 42"W	HH18042SD	46	8.6	\$2871	\$2907

- ! Door is only available in Frosted Translucent Acrylic. Specify paint for frame.
- ! Can only install Sliding Door at the end of a run, not at a corner.

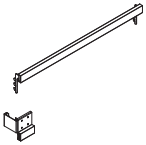

Mounting Kit for Abound Sliding Door					
For 30"W Panel	HHKDMK30	4	0.4	\$177	\$189
For 36"W Panel	HHKDMK36	5	0.5	\$185	\$197
For 42"W Panel	HHKDMK42	6	0.5	\$191	\$203
For 48"W Panel	HHKDMK48	7	0.5	\$201	\$213

NOTES: Specify paint.

NOTES:

- The Sliding Doors are available in 50", 65", and 80"H models and can mount to 30", 36", 42", and 48"W panels.
- All doors are 42" wide, provide a 36"W opening, and are non-handed.
- ! A Mounting Bracket Kit must be ordered for each door corresponding to the mounting panels width (30", 36", 42", or 48"W).

HOW TO SPECIFY

<p>Select Model Number</p> <p>HH15042SD . T1</p>	<p>Select Paint Color</p> <p>See page 395</p>
---	--

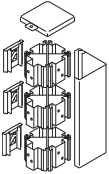
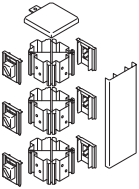
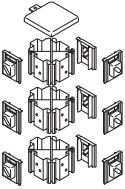
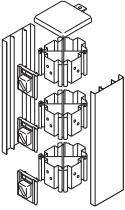

DESCRIPTION	MODEL	SHIP WEIGHT	CUBE	LIST PRICE BY PAINT GRADE	
				P1	P2
 <p>“L” 90° Painted Connector 7”H Frame 15”H Frame 22”H Frame 30”H Frame 35”H Frame 42”H Frame 50”H Frame 65”H Frame 80”H Frame</p>	HRVC7PL	1	0.1	\$95	\$112
	HRVC15PL	2	0.1	\$106	\$123
	HRVC22PL	2	0.2	\$119	\$136
	HRVC30PL	3	0.3	\$136	\$153
	HRVC35PL	3	0.3	\$136	\$153
	HRVC42PL	4	0.4	\$148	\$165
	HRVC50PL	5	0.5	\$153	\$170
	HRVC65PL	6	0.6	\$162	\$179
HRVC80PL	6	0.8	\$168	\$185	
 <p>“T” 3-Way Painted Connector 7”H Frame 15”H Frame 22”H Frame 30”H Frame 35”H Frame 42”H Frame 50”H Frame 65”H Frame 80”H Frame</p>	HRVC7PT	1	0.1	\$95	\$112
	HRVC15PT	2	0.1	\$106	\$123
	HRVC22PT	2	0.2	\$119	\$136
	HRVC30PT	3	0.3	\$136	\$153
	HRVC35PT	3	0.3	\$136	\$153
	HRVC42PT	4	0.4	\$148	\$165
	HRVC50PT	5	0.5	\$153	\$170
	HRVC65PT	6	0.6	\$162	\$179
HRVC80PT	6	0.8	\$168	\$185	
 <p>“X” 4-Way Painted Connector 7”H Frame 15”H Frame 22”H Frame 30”H Frame 35”H Frame 42”H Frame 50”H Frame 65”H Frame 80”H Frame</p>	HRVC7PX	1	0.1	\$76	\$86
	HRVC15PX	2	0.1	\$87	\$97
	HRVC22PX	2	0.2	\$96	\$106
	HRVC30PX	3	0.3	\$106	\$116
	HRVC35PX	3	0.3	\$106	\$116
	HRVC42PX	4	0.4	\$143	\$153
	HRVC50PX	6	0.5	\$148	\$158
	HRVC65PX	7	0.6	\$153	\$163
HRVC80PX	6	0.8	\$162	\$172	
 <p>“S” Extended Straight Painted Connector 7”H Frame 15”H Frame 22”H Frame 30”H Frame 35”H Frame 42”H Frame 50”H Frame 65”H Frame 80”H Frame</p>	HRVC7PS	1	0.1	\$116	\$133
	HRVC15PS	2	0.1	\$127	\$144
	HRVC22PS	2	0.2	\$137	\$154
	HRVC30PS	3	0.3	\$148	\$165
	HRVC35PS	3	0.3	\$148	\$165
	HRVC42PS	4	0.4	\$170	\$187
	HRVC50PS	6	0.5	\$178	\$195
	HRVC65PS	7	0.6	\$189	\$206
HRVC80PS	7	0.8	\$203	\$220	

NOTES:

- All connectors include a light-gap strip.
- Abound connectors utilize a universal connector block designed to make one connection to the panel.
- Bracket clips come standard.
- 7”H connectors include one connector block; 15”H, 22”H, 30”H include two connector blocks; 50”H includes three connector blocks and 65”H includes four connector blocks.
- Connectors ship complete with trim.
- Outer trim snaps easily into place.
- Extended Straight Connectors are used to keep a frame run dimensionally consistent with opposing frame runs. Add 2¾” to the length of the run with each Extended Straight Connector used.

! Trim with Abound connectors can only be attached to connectors, not on panels.

HOW TO SPECIFY

<p>Select Model Number</p> <p>HRVC35PL</p>	<p>Select Paint Color</p> <p>See page 395</p> <p>T4</p>
---	--

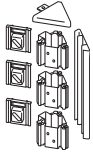

DESCRIPTION	MODEL	SHIP WEIGHT	CUBE	LIST PRICE BY PAINT GRADE	
				P1	P2
“Y” 120° Degree, Two-Sided, Painted Connector					
35”H Frame	HRVC35PY2	3	0.3	\$136	\$153
42”H Frame	HRVC42PY2	4	0.4	\$148	\$165
50”H Frame	HRVC50PY2	5	0.5	\$162	\$179
65”H Frame	HRVC65PY2	6	0.6	\$178	\$195

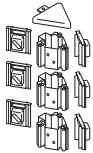

“Y” 120° Degree, Three-Sided, Painted Connector					
35”H Frame	HRVC35PY3	3	0.3	\$119	\$136
42”H Frame	HRVC42PY3	4	0.4	\$136	\$153
50”H Frame	HRVC50PY3	5	0.5	\$148	\$165
65”H Frame	HRVC65PY3	6	0.6	\$162	\$179

NOTES:

- 35”H-42”H connectors include two universal connector blocks, 50”H includes three brackets and 65”H includes four brackets.
- Use Y Connectors for 120° applications.
- Abound connectors utilize a universal connector block designed to make one connection to the panel.
- Connectors ship complete with trim.
- Bracket clips come standard.
- Outer trim snaps easily into place.

HOW TO SPECIFY

<p>Select Model Number</p> <p>HRVC35PY2</p>	<p>Select Paint Color</p> <p>See page 395</p> <p>T3</p>
--	--



Variable Height Finished End and Wall Starter Kits

	DESCRIPTION	MODEL	SHIP		LIST PRICE BY PAINT GRADE	
			WEIGHT	CUBE	P1	P2
	Finished End					
	15"H Finished End	HRVC15PF	1 Ⓢ	0.1	\$64	\$81
	30"H Finished End	HRVC30PF	2 Ⓢ	0.3	\$78	\$95
	35"H Finished End	HRVC35PF	2 Ⓢ	0.3	\$78	\$95
	42"H Finished End	HRVC42PF	2 Ⓢ	0.4	\$87	\$104
	50"H Finished End	HRVC50PF	3 Ⓢ	0.5	\$94	\$111
	65"H Finished End	HRVC65PF	4 Ⓢ	0.6	\$99	\$116
	80"H Finished End	HRVC80PF	4 Ⓢ	0.8	\$105	\$122
	Variable Height Painted Finished End					
	7" Variable Height Finished End	HRVC7PFV	1 Ⓢ	0.1	\$64	\$74
	15" Variable Height Finished End	HRVC15PFV	1 Ⓢ	0.1	\$64	\$74
	22" Variable Height Finished End	HRVC22PFV	2 Ⓢ	0.2	\$78	\$88
	30" Variable Height Finished End	HRVC30PFV	2 Ⓢ	0.3	\$78	\$88
	Variable Height Painted Finished End Over Connector					
	7" Variable Height Finished End Over Connector	HRVC7PFT	1 Ⓢ	0.1	\$64	\$74
	15" Variable Height Finished End Over Connector	HRVC15PFT	1 Ⓢ	0.1	\$64	\$74
	22" Variable Height Finished End Over Connector	HRVC22PFT	2 Ⓢ	0.2	\$78	\$88
	30" Variable Height Finished End Over Connector	HRVC30PFT	2 Ⓢ	0.3	\$78	\$88
	Frameless Glass Variable Height Trim					
	7½"H	HRVC7FFV	1	0.1	\$58	\$67
	15"H	HRVC15FFV	1	0.1	\$85	\$94
	Specify paint only.					
	❗ Model only used with Frameless Glass on page 434.					
	SPECIFYING EXAMPLE: HRVC7FFV.T1					
	Wall Starter Kit					
	65"H	HRVC65PW	5 Ⓢ	0.6	\$178	\$195
	Permanent Wall Hanger Kit					
	2½"W x 7/8"D x 66"H	HRVC35PCE	6 Ⓢ	0.7	\$220	\$240
	4¼"W x 7/8"D x 66"H	HRVC35PCM	3 Ⓢ	0.7	\$115	\$125
	❗ Anchor devices are not supplied with this model. Refer to Abound® Installation instructions for appropriate hardware. Attachment to masonry walls is not recommended.					
	Specify paint					

NOTES:

- Snaps easily onto end of frame.
- 35"H end trim includes top cap and vertical trim.
- 15"H and 30"H Finished End Trims do not include a top cap. These are only used for stacking frames which utilize the top trim and cap from the base frame to which they are attached.
- 42", 50" and 65"H finished end trim includes painted top transition piece, vertical trim and carpet grippers for extra stability.

- End trim is full-length to floor; no baserail cap is necessary.
- Finished Ends include top cap trim. Adds 1½" to panel run.
- Wall Starter Kit allows panel to start from a wall. Specify trim color.
- Wall Starter adds 1½" to length of panel run.
- Anchor devices are not supplied with the wall starter kits.

❗ Variable height trim and finished ends can only be attached to panels, not attached to connectors.

HOW TO SPECIFY

Select Model Number HRVC7PFT	Select Paint Color See page 395 T3
--	---

WALL HANGER BARS AND OFF-MODULE BRACKET

GSA SIN 33721



Icon Legend on page 19

WORKSTATIONS

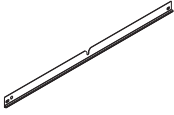

DESCRIPTION	MODEL	SHIP WEIGHT	CUBE	LIST PRICE BY PAINT GRADE	
				P1	P2
Wall Hanger Segment Bars					
24"W	HRVFSBW24	2	0.4	\$32	N/A
30"W	HRVFSBW30	2	0.4	\$32	N/A
36"W	HRVFSBW36	3	0.5	\$34	N/A
42"W	HRVFSBW42	3	0.5	\$38	N/A
48"W	HRVFSBW48	3	0.6	\$42	N/A
60"W	HRVFSBW60	4	0.7	\$46	N/A

ⓘ Includes two tile bars. Top bar may only be used in the top uppermost position on Wall Track. Bottom bar can be used in the bottom position at any point on the wall hangers. When segmenting tiles on Wall Hangers, standard Segment Bars (page 419) must be ordered for placement between each tile reveal or at the top position of a single tile that is not in the uppermost position.

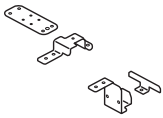

Off-Module Bracket Kit	HRVOMOD	2	0.1	\$87	\$97
-------------------------------	----------------	---	-----	-------------	-------------

- Includes top and bottom attachment brackets and top trim finished end.
- Installation requires defacing of the top tile.

ⓘ Cannot be mounted in locations where the bottom bracket covers electrical cutouts in the base pathway on parent run panels.

HOW TO SPECIFY

Select Model Number

HRVFSBW24



ABOUT® Tackable Acoustical Tiles

DESCRIPTION	MODEL	SHIP WEIGHT	CUBE	LIST PRICE BY FABRIC GRADE								
				AA	A	B	C	D	E	F	G	
7½" H Tackable Acoustical Fabric Tiles												
7½" H x 24" W	HRVT0724T	2 ☉	0.4	\$63	\$67	\$70	\$72	\$78	\$83	\$88	\$91	
7½" H x 30" W	HRVT0730T	2 ☉	0.5	\$74	\$78	\$81	\$85	\$91	\$98	\$101	\$104	
7½" H x 36" W	HRVT0736T	2 ☉	0.6	\$79	\$83	\$86	\$90	\$96	\$103	\$106	\$109	
7½" H x 42" W	HRVT0742T	2 ☉	0.7	\$87	\$92	\$96	\$100	\$110	\$113	\$117	\$121	
7½" H x 48" W	HRVT0748T	2 ☉	0.8	\$93	\$98	\$102	\$106	\$116	\$119	\$123	\$127	
7½" H x 60" W	HRVT0760T	3 ☉	1.0	\$111	\$131	\$135	\$140	\$152	\$156	\$159	\$162	
15" H Tackable Acoustical Fabric Tiles												
15" H x 24" W	HRVT1524T	2 ☉	0.8	\$65	\$74	\$82	\$90	\$106	\$124	\$140	\$148	
15" H x 30" W	HRVT1530T	2 ☉	0.9	\$66	\$77	\$87	\$97	\$119	\$140	\$151	\$161	
15" H x 36" W	HRVT1536T	2 ☉	1.1	\$73	\$84	\$94	\$104	\$126	\$147	\$158	\$168	
15" H x 42" W	HRVT1542T	2 ☉	1.3	\$75	\$88	\$100	\$115	\$148	\$159	\$169	\$180	
15" H x 48" W	HRVT1548T	2 ☉	1.5	\$81	\$94	\$106	\$121	\$154	\$165	\$175	\$186	
15" H x 60" W	HRVT1560T	3 ☉	1.8	\$94	\$107	\$119	\$134	\$167	\$178	\$188	\$199	
22½" H Tackable Acoustical Tiles												
22½" H x 24" W	HRVT2224T	2	1.1	\$75	\$85	\$94	\$104	\$123	\$145	\$159	\$168	
22½" H x 30" W	HRVT2230T	2	1.4	\$78	\$90	\$101	\$114	\$137	\$165	\$192	\$202	
22½" H x 36" W	HRVT2236T	2	1.6	\$85	\$100	\$113	\$124	\$161	\$191	\$202	\$212	
22½" H x 42" W	HRVT2242T	2	1.9	\$92	\$107	\$120	\$134	\$177	\$201	\$212	\$223	
22½" H x 48" W	HRVT2248T	2	2.2	\$98	\$113	\$126	\$140	\$183	\$207	\$218	\$229	
22½" H x 60" W	HRVT2260T	3	2.6	\$113	\$128	\$141	\$155	\$198	\$222	\$233	\$244	
30" H Tackable Acoustical Tiles												
30" H x 24" W	HRVT3024T	2 ☉	1.4	\$89	\$100	\$110	\$121	\$143	\$170	\$181	\$191	
30" H x 30" W	HRVT3030T	2 ☉	1.8	\$93	\$106	\$118	\$133	\$158	\$192	\$236	\$246	
30" H x 36" W	HRVT3036T	2 ☉	2.1	\$100	\$118	\$134	\$146	\$199	\$237	\$248	\$258	
30" H x 42" W	HRVT3042T	3 ☉	2.4	\$113	\$129	\$144	\$156	\$210	\$247	\$259	\$269	
30" H x 48" W	HRVT3048T	3 ☉	2.8	\$121	\$137	\$152	\$164	\$218	\$255	\$267	\$277	
30" H x 60" W	HRVT3060T	4 ☉	3.4	\$136	\$152	\$167	\$179	\$233	\$270	\$282	\$292	
37" H Tackable Acoustical Tiles												
37" H x 24" W	HRVT3724T	2 ☉	2.0	\$102	\$118	\$133	\$151	\$204	\$236	\$248	\$258	
37" H x 30" W	HRVT3730T	3 ☉	2.4	\$116	\$132	\$147	\$165	\$218	\$250	\$262	\$272	
37" H x 36" W	HRVT3736T	4 ☉	2.9	\$132	\$151	\$170	\$191	\$255	\$302	\$313	\$324	
37" H x 42" W	HRVT3742T	4 ☉	3.4	\$148	\$169	\$189	\$213	\$294	\$342	\$352	\$363	
37" H x 48" W	HRVT3748T	5 ☉	3.8	\$156	\$177	\$199	\$222	\$305	\$354	\$366	\$377	
37" H x 60" W	HRVT3760T	6	4.6	\$178	\$204	\$230	\$261	\$343	\$403	\$414	\$426	

☉ Segment bars ordered separately. See page 419.

NOTES:

- Tiles attach directly onto the panels. No additional hardware is needed.
- Tiles are non-dedicated.
- For monolithic applications, subtract 5" from the frame height to determine monolithic tile height.
- ☉ Fabric tiles have a Class A fire rating.
- ☉ Tiles do not include segment bars, must be ordered separately. See page 419. Not needed on monolithic tiles.
- ☉ One segment bar required per panel reveal, per panel side.

HOW TO SPECIFY

<p>Select Model Number</p> <p>HRVT1524T</p>	<p>Select Fabric Color</p> <p>See pages 396-397</p> <p>APN11</p>
---	--

ABOUND[®] Tackable Acoustical Tiles

GSA SIN 33721



Icon Legend on page 19

WORKSTATIONS



DESCRIPTION	MODEL	SHIP WEIGHT	CUBE	LIST PRICE BY FABRIC GRADE							
				AA	A	B	C	D	E	F	G
45°H Tackable Acoustical Tiles											
45°H x 24°W	HRVT4524T	2	2.3	\$112	\$131	\$151	\$172	\$238	\$286	\$297	\$309
45°H x 30°W	HRVT4530T	3	2.9	\$128	\$149	\$169	\$194	\$277	\$325	\$337	\$349
45°H x 36°W	HRVT4536T	5	3.4	\$152	\$173	\$195	\$218	\$301	\$350	\$362	\$373
45°H x 42°W	HRVT4542T	5	4.0	\$178	\$199	\$219	\$244	\$326	\$375	\$387	\$399
45°H x 48°W	HRVT4548T	6	4.5	\$201	\$222	\$250	\$267	\$350	\$399	\$411	\$422
45°H x 60°W	HRVT4560T	7	5.6	\$219	\$245	\$272	\$303	\$384	\$444	\$456	\$468
60°H Tackable Acoustical Tiles											
60°H x 24°W	HRVT6024T	3	3.0	\$132	\$163	\$196	\$230	\$318	\$372	\$385	\$426
60°H x 30°W	HRVT6030T	4	3.7	\$150	\$186	\$224	\$261	\$353	\$418	\$431	\$495
60°H x 36°W	HRVT6036T	6	4.4	\$175	\$211	\$249	\$284	\$377	\$442	\$456	\$520
60°H x 42°W	HRVT6042T	6	5.1	\$189	\$230	\$274	\$310	\$419	\$484	\$497	\$588
60°H x 48°W	HRVT6048T	7	5.8	\$214	\$255	\$299	\$335	\$444	\$553	\$567	\$657
60°H x 60°W	HRVT6060T	9	7.2	\$228	\$275	\$323	\$359	\$507	\$589	\$601	\$692

Segment bars ordered separately. See page 419.

NOTES:

- Tiles are non-dedicated.
- Tiles attach directly onto the panels. No additional hardware is needed.
- For monolithic applications, subtract 5" from the frame height to determine monolithic tile height.
- Fabric tiles have a Class A fire rating.
- Tiles do not include segment bars, must be ordered separately. See page 419. Not needed on monolithic tiles.
- One segment bar required per panel reveal, per panel side.

HOW TO SPECIFY

<p>Select Model Number</p> <p>HRVT4524T</p>	<p>Select Fabric Color</p> <p>See pages 396-397</p> <p>APN11</p>
---	--



ABOUND® Power/Data Fabric Tiles

DESCRIPTION	MODEL	SHIP WEIGHT	CUBE	LIST PRICE BY FABRIC GRADE								
				AA	A	B	C	D	E	F	G	
15"H Power/Data Fabric Tiles												
15"H x 24"W	HRVT1524E	2 Ⓢ	0.8	\$130	\$139	\$147	\$155	\$171	\$189	\$205	\$213	
15"H x 30"W	HRVT1530E	2 Ⓢ	0.9	\$131	\$142	\$152	\$162	\$184	\$205	\$216	\$226	
15"H x 36"W	HRVT1536E	2 Ⓢ	1.1	\$138	\$149	\$159	\$169	\$191	\$212	\$223	\$233	
15"H x 42"W	HRVT1542E	2 Ⓢ	1.3	\$140	\$153	\$165	\$180	\$213	\$224	\$234	\$245	
15"H x 48"W	HRVT1548E	2 Ⓢ	1.5	\$146	\$159	\$171	\$186	\$219	\$230	\$240	\$251	
15"H x 60"W	HRVT1560E	3 Ⓢ	1.8	\$158	\$171	\$183	\$198	\$231	\$242	\$252	\$263	
30"H Power/Data Fabric Tiles												
30"H x 24"W	HRVT3024E	2 Ⓢ	1.4	\$152	\$163	\$173	\$184	\$206	\$233	\$244	\$254	
30"H x 30"W	HRVT3030E	2 Ⓢ	1.8	\$157	\$170	\$182	\$197	\$222	\$256	\$300	\$310	
30"H x 36"W	HRVT3036E	2 Ⓢ	2.1	\$166	\$184	\$200	\$212	\$265	\$303	\$314	\$324	
30"H x 42"W	HRVT3042E	3 Ⓢ	2.4	\$182	\$198	\$213	\$225	\$279	\$316	\$328	\$338	
30"H x 48"W	HRVT3048E	3 Ⓢ	2.8	\$187	\$203	\$218	\$230	\$284	\$321	\$333	\$343	
30"H x 60"W	HRVT3060E	4 Ⓢ	3.4	\$201	\$217	\$232	\$244	\$298	\$335	\$347	\$357	
37"H Power/Data Fabric Tiles												
37"H x 24"W	HRVT3724E	2 Ⓢ	2.0	\$168	\$184	\$199	\$217	\$270	\$302	\$314	\$324	
37"H x 30"W	HRVT3730E	3 Ⓢ	2.4	\$184	\$200	\$215	\$233	\$286	\$318	\$330	\$340	
37"H x 36"W	HRVT3736E	4 Ⓢ	2.9	\$194	\$213	\$232	\$253	\$317	\$364	\$375	\$386	
37"H x 42"W	HRVT3742E	4 Ⓢ	3.4	\$208	\$229	\$249	\$273	\$354	\$402	\$412	\$423	
37"H x 48"W	HRVT3748E	5 Ⓢ	3.8	\$223	\$244	\$266	\$289	\$372	\$421	\$433	\$444	
37"H x 60"W	HRVT3760E	6	4.7	\$245	\$271	\$297	\$328	\$410	\$470	\$481	\$493	

ⓘ Segment bars ordered separately. See page 419.

NOTES:

- Power/Data tiles are tackable and acoustical.
- Tiles attach directly onto the panels. No additional hardware is needed.
- Tiles are non-dedicated.
- 24"W tiles have one port. Other widths have two.
- Power/Data grommet opening is 2³/₁₆"W x 1³/₈"H. With glides retracted grommets are 30" from the floor and 10¹/₂" from the edge of the frame.
- Power/Data ports are factory installed.
- Ⓢ Fabric tiles have a Class A fire rating.
- ⓘ Ports on all tile sizes are located above the worksurface. Tiles cannot be flipped to change port location.
- ⓘ Tiles do not include segment bars, must be ordered separately. See page 419. Can be used in any combination.
- ⓘ One segment bar required per panel reveal, per panel side.
- ⓘ Electrical mounting brackets must be ordered separately. See page 577.

HOW TO SPECIFY

<p>Select Model Number</p> <p>HRVT1524E</p>	<p>Select Fabric Color</p> <p>See pages 396-397</p> <p>APN11</p>	<p>Select Electrical Power/Data Grommet Color</p> <p>See page 395</p> <p>T5</p>
--	---	--

ABOUND[®] Power/Data Fabric Tiles

GSA SIN 33721



Icon Legend on page 19

WORKSTATIONS

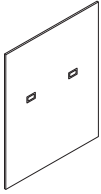

DESCRIPTION	MODEL	SHIP WEIGHT	CUBE	LIST PRICE BY FABRIC GRADE									
				AA	A	B	C	D	E	F	G		
45" H Power/Data Fabric Tiles													
45" H x 24" W	HRVT4524E	2	2.3	\$181	\$200	\$220	\$241	\$307	\$355	\$366	\$378		
45" H x 30" W	HRVT4530E	3	2.9	\$194	\$215	\$235	\$260	\$343	\$391	\$403	\$415		
45" H x 36" W	HRVT4536E	5	3.4	\$221	\$242	\$264	\$287	\$370	\$419	\$431	\$442		
45" H x 42" W	HRVT4542E	5	4.0	\$245	\$266	\$286	\$311	\$393	\$442	\$454	\$466		
45" H x 48" W	HRVT4548E	6	4.5	\$270	\$291	\$319	\$336	\$419	\$468	\$480	\$491		
45" H x 60" W	HRVT4560E	7	5.6	\$289	\$315	\$342	\$373	\$454	\$514	\$526	\$538		

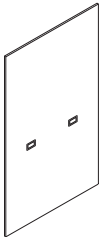

60" H Power/Data Fabric Tiles													
60" H x 24" W	HRVT6024E	3	3.0	\$198	\$229	\$262	\$296	\$384	\$438	\$451	\$492		
60" H x 30" W	HRVT6030E	4	3.7	\$219	\$255	\$293	\$330	\$422	\$487	\$500	\$564		
60" H x 36" W	HRVT6036E	6	4.4	\$242	\$278	\$316	\$351	\$444	\$509	\$523	\$587		
60" H x 42" W	HRVT6042E	6	5.1	\$258	\$299	\$343	\$379	\$488	\$553	\$566	\$657		
60" H x 48" W	HRVT6048E	7	5.8	\$283	\$324	\$368	\$404	\$513	\$622	\$636	\$726		
60" H x 60" W	HRVT6060E	9	7.2	\$297	\$344	\$392	\$428	\$576	\$658	\$670	\$761		

Segment bars ordered separately. See page 419.

NOTES:



- Tiles are non-dedicated.
- Tiles attach directly onto the panels. No additional hardware is needed.
- 24" W tiles have one port. Other widths have two.
- Power/Data grommet opening is 2 1/8" W x 1 3/8" H. With glides retracted grommet are 30" from the floor and 10 1/2" from the edge of the frame.
- Power/Data ports are factory installed.
- Fabric tiles have a Class A fire rating.
- Ports on all tile sizes are located above the worksurface. Tiles cannot be flipped to change port location.
- Tiles do not include segment bars, must be ordered separately. See page 419. Can be used in any combination.
- One segment bar required per panel reveal, per panel side.
- Electrical mounting brackets must be ordered separately. See page 577.

HOW TO SPECIFY

<p>Select Model Number</p> <p>HRVT4524E</p>	<p>Select Fabric Color</p> <p>See pages 396-397</p> <p>APN11</p>	<p>Select Electrical Power/Data Grommet Color</p> <p>See page 395</p> <p>T5</p>
---	--	---

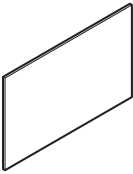
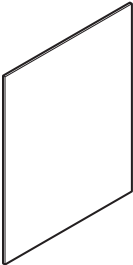

ABOUND® Hard-surface Tiles

	DESCRIPTION	MODEL	SHIP WEIGHT	CUBE	LIST PRICE BY LAMINATE GRADE	
					L1	L2
	15" Hard-surface Tile and Mounting Kit					
	15"H x 24"W	HRVT1524HS2	11	0.8	\$216	\$226
	15"H x 30"W	HRVT1530HS2	13	0.9	\$227	\$237
	15"H x 36"W	HRVT1536HS2	15	1.1	\$243	\$253
	15"H x 42"W	HRVT1542HS2	17	1.3	\$258	\$268
	15"H x 48"W	HRVT1548HS2	21	1.5	\$270	\$285
	15"H x 60"W	HRVT1560HS2	25	1.8	\$306	\$321
	30" Hard-surface Tile and Mounting Kit					
	30"H x 24"W	HRVT3024HS2	17	1.4	\$264	\$279
	30"H x 30"W	HRVT3030HS2	19	1.8	\$285	\$300
	30"H x 36"W	HRVT3036HS2	21	2.1	\$316	\$331
	30"H x 42"W	HRVT3042HS2	24	2.4	\$345	\$360
	30"H x 48"W	HRVT3048HS2	28	2.8	\$365	\$385
	30"H x 60"W	HRVT3060HS2	30	3.4	\$400	\$420
	37" Hard-surface Tile and Mounting Kit					
	37"H x 24"W	HRVT3724HS2	17	1.4	\$322	\$342
	37"H x 30"W	HRVT3730HS2	17	1.8	\$355	\$375
	37"H x 36"W	HRVT3736HS2	19	2.1	\$390	\$410
	37"H x 42"W	HRVT3742HS2	21	2.4	\$429	\$449
	37"H x 48"W	HRVT3748HS2	24	2.8	\$464	\$489
	37"H x 60"W	HRVT3760HS2	30	3.4	\$525	\$550

NOTES:

- Tiles are made from high-pressure laminate.
- Available in all standard HON laminates.
- On woodgrain laminates, grain direction is vertical.
- Specify paint color.
- 15"H and 30"H tiles are non-dedicated and can be used in any tile position (except on 42"H frames.)
- ❗ All tiles ship with Custom Bracket Kit installed on the tile.
- ❗ One segment bar is required per panel reveal, per panel side.
- ❗ Tiles do not ship with segment bars — must be ordered separately. See page 419. Segment bars are not needed for 42"H monolithic tiles.

HOW TO SPECIFY

<p>Select Model Number</p> <p>HRVT1524HS2</p>	<p>Select Laminate Color</p> <p>See page 395</p> <p>H</p>	<p>Select Paint Color</p> <p>See page 395</p> <p>T1</p>
--	--	--

ABOUND® Clear Glass Tiles

GSA SIN 33721



Icon Legend on page 19

WORKSTATIONS

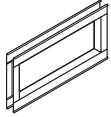

DESCRIPTION

15"H Clear Glass Tiles

15"H x 24"W
15"H x 30"W
15"H x 36"W
15"H x 42"W
15"H x 48"W
15"H x 60"W

MODEL

SHIP WEIGHT

CUBE

LIST PRICE BY PAINT GRADE

P1

P2

HRVT1524G	12	0.8	\$467	\$486
HRVT1530G	15	0.9	\$495	\$514
HRVT1536G	17	1.1	\$523	\$542
HRVT1542G	19	1.3	\$558	\$578
HRVT1548G	20	1.5	\$600	\$620
HRVT1560G	26	1.8	\$717	\$737

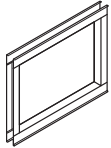

30"H Clear Glass Tiles

30"H x 24"W
30"H x 30"W
30"H x 36"W
30"H x 42"W
30"H x 48"W
30"H x 60"W

HRVT3024G	15	1.4	\$621	\$641
HRVT3030G	21	1.8	\$662	\$682
HRVT3036G	22	2.1	\$706	\$726
HRVT3042G	25	2.4	\$763	\$783
HRVT3048G	28	2.9	\$820	\$840
HRVT3060G	33	3.4	\$962	\$982

! Segment bars ordered separately. See page 419.

NOTES:

- Glass is off-set and may be placed on either side of the frame.
- Tile is a single-pane, tempered glass.
- For worksurfaces that can be used with both Abound® and Accelerate® systems, see pages 581-591.
- ! Glass tiles have a Class A fire rating.
- ! Tiles do not include segment bars, must be ordered separately. See page 419. Can be used in any combination.
- ! Glass tiles cannot be placed in the second tier (20"-35" range) due to interference with the horizontal support. Glass tiles cannot be placed in the bottom tier of a frame.
- ! Glass tiles will not work with 42"H frames — use stackers with glass on 42½"H panels.
- ! When stacking on 42½"H frames, panel slots will be off by ½" compared to any other height panel.

HOW TO SPECIFY

Select
Model Number

Select
Interior Shroud Paint Color

See page 395. Available in all P1/P2 paint colors.

HRVT1524G . T1



Icon Legend on page 19

ABOUND® Frosted Glass Tiles

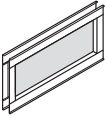
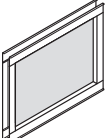
	DESCRIPTION	MODEL	SHIP WEIGHT	CUBE	LIST PRICE BY PAINT GRADE	
					P1	P2
	15”H Frosted Glass Tiles					
	15”H x 24”W	HRVT1524R	12	0.8	\$575	\$594
	15”H x 30”W	HRVT1530R	15	0.9	\$617	\$636
	15”H x 36”W	HRVT1536R	17	1.1	\$658	\$677
	15”H x 42”W	HRVT1542R	19	1.3	\$706	\$726
	15”H x 48”W	HRVT1548R	20	1.5	\$761	\$781
	15”H x 60”W	HRVT1560R	26	1.8	\$890	\$910
	30”H Frosted Glass Tiles					
	30”H x 24”W	HRVT3024R	15	1.4	\$812	\$832
	30”H x 30”W	HRVT3030R	21	1.8	\$867	\$887
	30”H x 36”W	HRVT3036R	22	2.1	\$924	\$944
	30”H x 42”W	HRVT3042R	25	2.4	\$995	\$1015
	30”H x 48”W	HRVT3048R	28	2.9	\$1064	\$1084
	30”H x 60”W	HRVT3060R	33	3.4	\$1221	\$1241

! Segment bars ordered separately. See page 419.

NOTES:

- Glass is off-set and may be placed on either side of the frame.
- Tile is a single-pane, tempered glass.
- For worksurfaces that can be used with both Abound® and Accelerate® systems, see pages 581-591.
- ! Glass tiles have a Class A fire rating.
- ! Tiles do not include segment bars, must be ordered separately. See page 419. Can be used in any combination.
- ! Glass tiles cannot be placed in the second tier (20”-35” range) due to interference with the horizontal support. Glass tiles cannot be placed in the bottom tier of a frame.
- ! Glass tiles will not work with 42”H frames — use stackers with glass on 42½”H panels.
- ! When stacking on 42½”H frames, panel slots will be off by ½” compared to any other height panel.

HOW TO SPECIFY

<p>Select Model Number</p> <div style="border: 1px solid black; display: flex; gap: 2px; padding: 2px;"> HRVT1524R </div>	<p>Select Interior Shroud Paint Color</p> <p>See page 395. Available in all P1/P2 paint colors.</p> <div style="border: 1px solid black; display: flex; gap: 2px; padding: 2px;"> T1 </div>
--	---

ABOUND® Frameless Glass

GSA SIN 33721



Icon Legend on page 19

WORKSTATIONS

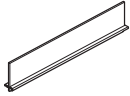

DESCRIPTION

7 1/2" H Frameless Glass

7 1/2" H x 24" W
7 1/2" H x 30" W
7 1/2" H x 36" W
7 1/2" H x 42" W
7 1/2" H x 48" W
7 1/2" H x 54" W (24" + 30")
7 1/2" H x 60" W
7 1/2" H x 66" W (30" + 36")
7 1/2" H x 72" W (36" + 36")
7 1/2" H x 78" W (48" + 30")
7 1/2" H x 84" W (36" + 48" or 42" + 42")
7 1/2" H x 90" W (42" + 48")
7 1/2" H x 96" W (48" + 48" or 36" + 60")

MODEL	SHIP WEIGHT	CUBE	CLEAR GLASS	FROSTED GLASS
HRVT0724F	18	0.5	\$415	\$450
HRVT0730F	18	0.5	\$444	\$481
HRVT0736F	21	0.6	\$515	\$558
HRVT0742F	25	0.7	\$543	\$589
HRVT0748F	28	0.8	\$580	\$630
HRVT0754F	28	0.8	\$645	\$699
HRVT0760F	35	1.0	\$709	\$770
HRVT0766F	35	1.0	\$777	\$843
HRVT0772F	42	1.9	\$843	\$915
HRVT0778F	42	1.9	\$906	\$983
HRVT0784F	50	2.1	\$967	\$1050
HRVT0790F	50	2.1	\$1034	\$1121
HRVT0796F	57	2.4	\$1094	\$1186

NOTES: For models 54" W-96" W, glass can span multiple panel widths. See examples of panel sizes by glass width above.

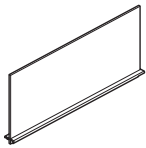

15" H Frameless Glass

15" H x 24" W
15" H x 30" W
15" H x 36" W
15" H x 42" W
15" H x 48" W
15" H x 54" W (24" + 30")
15" H x 60" W
15" H x 66" W (30" + 36")
15" H x 72" W (36" + 36")
15" H x 78" W (48" + 30")
15" H x 84" W (36" + 48" or 42" + 42")
15" H x 90" W (42" + 48")
15" H x 96" W (48" + 48" or 36" + 60")

HRVT1524F	28	1.5	\$466	\$503
HRVT1530F	28	1.5	\$496	\$537
HRVT1536F	34	1.8	\$575	\$622
HRVT1542F	39	2.0	\$611	\$661
HRVT1548F	45	2.3	\$654	\$708
HRVT1554F	51	2.6	\$724	\$785
HRVT1560F	57	2.8	\$796	\$862
HRVT1566F	62	3.2	\$871	\$943
HRVT1572F	67	3.5	\$946	\$1024
HRVT1578F	63	3.7	\$1076	\$1164
HRVT1584F	78	3.9	\$1202	\$1301
HRVT1590F	74	4.2	\$1237	\$1339
HRVT1596F	89	4.4	\$1272	\$1378

NOTES: For models 54" W-96" W, glass can span multiple panel widths. See suggested panel sizes by glass width above.

NOTES:

- Tile is a single-pane, 3/8" laminated safety glass.
- Available in clear or frosted glass.
- New top cap ships with Frameless Glass which fits around the glass insert.
- Frameless Glass can span multiple panels with one piece of glass.
- Lamination is in the center of the glass, making both clear and frosted glass a writable surface with dry-erase markers.
- ⚠ Glass tiles have a Class A fire rating.
- ⚠ Frameless Glass can only be used on the top of panels. Glass integrates into top cap trim.
- ⚠ Power and data cords cannot lay in the top of panel frames when using frameless glass.
- ⚠ Variable height trim for Frameless Glass must be ordered when using panel heights one step up; see page 425.
- ⚠ Cannot hang or stack on top of Frameless Glass.
- ⚠ Abound® power pole cannot be used with Frameless Glass. Freestanding power pole HH870070 can be used at the end of run or one panel needs to be specified without Frameless Glass for ceiling in-feed to enter the panel.

HOW TO SPECIFY

Select Model Number

HRVT0724F

Select Glass Option

- G Clear
 - R Frosted
- (Not specified for HRVT24R-60R models)

G

Select Paint Color

- See page 395
- P1 Paint (no upcharge)
- P2 Paint (\$17 upcharge)

T1



ABOUND® Pass-thru Tiles

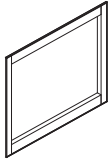

DESCRIPTION	MODEL	SHIP WEIGHT	CUBE	LIST PRICE BY PAINT GRADE	
				P1	P2
30"H Pass-Thru Tile Kit					
22½"H x 24"W	HRVT3024P	8	1.2	\$129	\$149
22½"H x 30"W	HRVT3030P	8	1.5	\$147	\$167
22½"H x 36"W	HRVT3036P	9	1.8	\$162	\$182
22½"H x 42"W	HRVT3042P	10	2.1	\$169	\$189
22½"H x 48"W	HRVT3048P	11	2.3	\$187	\$207
22½"H x 60"W	HRVT3060P	12	2.9	\$194	\$214

NOTES: Pass-thru opening is 22½"H. To be used with 30"H tiles. Order one 7½"H fabric tiles per pass-thru tile, if finishing only one side of panel.

ⓘ Must order a quantity of two (2) 7½"H fabric tiles per pass-thru tile, if finishing both sides of panel.

HOW TO SPECIFY

<p>Select Model Number</p> <p>HRVT3024P</p>	<p>Select Paint Color</p> <p>See page 395</p> <p>T1</p>
---	---

DESCRIPTION	MODEL	SHIP WEIGHT	CUBE	LIST PRICE BY FABRIC GRADE								
				AA	A	B	C	D	E	F	G	
7½"H Fabric Tackable Tile												
7½"H x 24"W	HRVT0724T	2 Ⓢ	1.4	\$63	\$67	\$70	\$72	\$78	\$83	\$88	\$91	
7½"H x 30"W	HRVT0730T	2 Ⓢ	1.8	\$74	\$78	\$81	\$85	\$91	\$98	\$101	\$104	
7½"H x 36"W	HRVT0736T	2 Ⓢ	2.1	\$79	\$83	\$86	\$90	\$96	\$103	\$106	\$109	
7½"H x 42"W	HRVT0742T	2 Ⓢ	2.4	\$87	\$92	\$96	\$100	\$110	\$113	\$117	\$121	
7½"H x 48"W	HRVT0748T	2 Ⓢ	2.8	\$93	\$98	\$102	\$106	\$116	\$119	\$123	\$127	
7½"H x 60"W	HRVT0760T	3 Ⓢ	3.4	\$111	\$131	\$135	\$140	\$152	\$156	\$159	\$162	

NOTES:

- Order one 7½"H fabric tiles per pass-thru tile, if finishing only one side of panel.
- ⓘ Must order a quantity of two (2) 7½"H fabric tiles per pass-thru tile, if finishing both sides of panel.

HOW TO SPECIFY

<p>Select Model Number</p> <p>HRVT0724T</p>	<p>Select Fabric Color</p> <p>See pages 396-397</p> <p>APN15</p>
---	--

ABOUND[®] Slotted Tool Tiles

GSA SIN 33721



Icon Legend on page 19

WORKSTATIONS

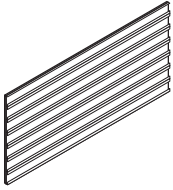

DESCRIPTION

15" H Slotted Tool Tiles

- 15" H x 24" W
- 15" H x 30" W
- 15" H x 36" W
- 15" H x 42" W
- 15" H x 48" W
- 15" H x 60" W

MODEL

SHIP WEIGHT

CUBE

LIST PRICE BY PAINT GRADE

P1

P2

P3

HRVT1524W	11	0.8	\$262	\$291	\$314
HRVT1530W	13	0.9	\$282	\$311	\$338
HRVT1536W	15	1.1	\$301	\$330	\$361
HRVT1542W	17	1.3	\$321	\$350	\$385
HRVT1548W	20	1.5	\$340	\$369	\$407
HRVT1560W	24	1.8	\$361	\$390	\$432

! Segment bars ordered separately. See page 419.

NOTES:

- Tiles made from sturdy aluminum extrusion and steel supports with a powder coat finish.
- Choose from hang-on accessories for a variety of organizational options. See page 437.
- ! Tiles do not include segment bars, must be ordered separately. See page 419. Can be used in any combination.
- ! Weight capacity of hang-on accessories should not exceed 80 pounds.

HOW TO SPECIFY

Select Model Number

HRVT1524W

Select Paint Color

See page 214 in the 2021 Shared Spaces Pricer
P1, P2, and P3 Paint Option

P8S

SYSTEMS PAPER MANAGEMENT SUPPORT BAR

GSA SIN 33721



Icon Legend on page 19

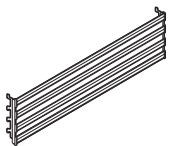

DESCRIPTION

Systems Paper Management Support Bars

- 24" W x 5" H
- 30" W x 5" H
- 36" W x 5" H
- 42" W x 5" H
- 48" W x 5" H
- 60" W x 5" H

MODEL

SHIP WEIGHT

CUBE

LIST PRICE BY PAINT GRADE

P1

P2

P3

HNPBWSW24	1.3	0.4	\$196	\$208	\$218
HNPBWSW30	1.5	0.5	\$209	\$221	\$231
HNPBWSW36	2.0	0.6	\$216	\$228	\$238
HNPBWSW42	5.0	0.7	\$228	\$240	\$250
HNPBWSW48	7.0	0.8	\$237	\$249	\$259
HNPBWSW60	9.0	0.9	\$269	\$281	\$291

! Recommended weight capacity not to exceed 80 pounds.

NOTES:

- Paper management bar attaches to Systems Panels to accommodate work flow accessories.

HOW TO SPECIFY

Select Model Number

HNPBWSW24





Select Paint Color

See page 214 in the 2021 Shared Spaces Pricer
P1, P2, and P3 Paint Option

P8S

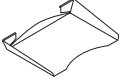
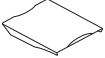

SYSTEMS PAPER MANAGEMENT ACCESSORIES

	DESCRIPTION	MODEL	SHIP WEIGHT	CUBE	LIST PRICE BY PAINT GRADE		
					P1	P2	P3
	Accessories for Slotted Tool Tiles Paper Shelf 15"W x 9½"D x 2"H NOTES: Paper Shelf holds letter size paper and inter-office envelopes.	HPPMPS	2	0.3	\$99	\$111	\$122
	Accessory Shelf 21¾"W x 9"D x 2"H NOTES: Accessory Shelf holds office supplies and personal effects.	HPPMAS	2	0.3	\$103	\$115	\$126
	Tray 9"W x 10¾"D x 2"H	HPPMPT	2	0.3	\$126	\$138	\$149
	Pencil Holder 5¼"W x 1½"D x 5"H	HPPMPB	1	0.2	\$103	\$115	\$126
	Sorter Tray 6"W x 10"D x 2½"H NOTES: Sorter Tray provides 3 slots for organizing files.	HPPMST	2	0.3	\$135	\$147	\$158
	Folder Bin 12¼"W x 1¼"D x 9"H NOTES: Folder Bin accommodates manila envelopes and can be hung from other folder binds to maximize storage.	HPPMFB	2	0.3	\$103	\$115	\$126

NOTES:

- For use with Slotted Tool Tiles and Systems Paper Management Support Bars on page 436.

HOW TO SPECIFY**Select Model Number**

H P P M P S .

Select Paint Color

See page 214 in the 2021 Shared Spaces Pricer
 P1, P2, and P3 Paint Option

P 8 S

ABOUND[®] Markerboard Tiles

GSA SIN 33721



Icon Legend on page 19

WORKSTATIONS

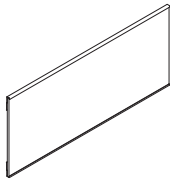

DESCRIPTION

15" H Markerboard Tiles

15" H x 24" W
15" H x 30" W
15" H x 36" W
15" H x 42" W
15" H x 48" W
15" H x 60" W

MODEL

SHIP WEIGHT

CUBE

LIST PRICE

HRVT1524M	4 ☹	1.2	\$238
HRVT1530M	4 ☹	1.8	\$255
HRVT1536M	5 ☹	2.5	\$267
HRVT1542M	5 ☹	3.4	\$284
HRVT1548M	6	4.3	\$291
HRVT1560M	7	6.7	\$303

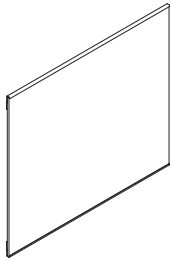

30" H Markerboard Tiles

30" H x 24" W
30" H x 30" W
30" H x 36" W
30" H x 42" W
30" H x 48" W
30" H x 60" W

HRVT3024M	6 ☹	1.2	\$261
HRVT3030M	7 ☹	1.8	\$280
HRVT3036M	8 ☹	2.5	\$308
HRVT3042M	10 ☹	3.4	\$328
HRVT3048M	11	4.3	\$361
HRVT3060M	13	6.7	\$399



Magnetic Markerboard Tray

15" Natural Aluminum

HRVTRAYM

4 ☹

0.4

\$60

! Natural Aluminum only, no need to specify paint.

NOTES:

- Markerboard tile has a painted, steel surface.
- Accepts magnetic accessories.
- Markerboard tray attaches to the tile magnetically. Order separately.
- ! Tiles do not include segment bars, must be ordered separately. See page 419. Can be used in any combination.
- ! Markerboard cleaning instructions: For everyday cleaning, use Chlorox[®] wipes. Use citrus cleaner if a permanent marker is used by accident. A citrus cleaner is not recommended for everyday use as it leaves residue.

HOW TO SPECIFY

Select
Model Number

Select
Paint Color

X No Specification Needed

HRVT1524M X



ABOUND[®]

Painted Metal Tiles

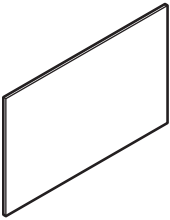
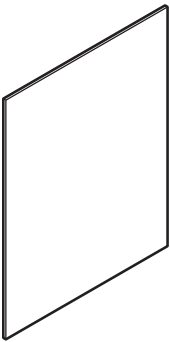
	DESCRIPTION	MODEL	SHIP WEIGHT	CUBE	LIST PRICE BY PAINT GRADE	
					P1	P2
	15'H Painted Metal Tile					
	15"H x 24"W	HRVT1524PM	4	1.2	\$152	\$173
	15"H x 30"W	HRVT1530PM	4	1.8	\$162	\$183
	15"H x 36"W	HRVT1536PM	5	2.5	\$175	\$196
	15"H x 42"W	HRVT1542PM	5	3.4	\$189	\$210
	15"H x 48"W	HRVT1548PM	6	4.3	\$208	\$229
	15"H x 60"W	HRVT1560PM	7	6.7	\$229	\$250
	30'H Painted Metal Tile					
	30"H x 24"W	HRVT3024PM	6	1.2	\$222	\$255
	30"H x 30"W	HRVT3030PM	7	1.8	\$241	\$274
	30"H x 36"W	HRVT3036PM	8	2.5	\$272	\$305
	30"H x 42"W	HRVT3042PM	10	3.4	\$291	\$324
	30"H x 48"W	HRVT3048PM	11	4.3	\$325	\$358
	30"H x 60"W	HRVT3060PM	13	6.7	\$365	\$398

NOTES:

- Painted steel construction.

! Tiles do not include segment bars, must be ordered separately. See page 419. Can be used in any combination.

HOW TO SPECIFY

<p>Select Model Number</p> <p>HRVT1524PM .</p>	<p>Select Paint Color</p> <p>See page 395</p> <p>T3</p>
--	---

ABOUND® Custom Material Bracket Kit

GSA SIN 33721



Icon Legend on page 19

WORKSTATIONS

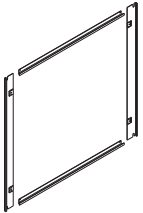
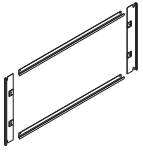

DESCRIPTION

Custom Material Mounting Bracket Kit

15"H x 24"W
15"H x 30"W
15"H x 36"W
15"H x 42"W
15"H x 48"W
15"H x 60"W

30"H x 24"W
30"H x 30"W
30"H x 36"W
30"H x 42"W
30"H x 48"W
30"H x 60"W

NOTES: Custom Material Bracket Kits can be ordered to use with Customer's Own Material. Please contact HON Customer Support for exact dimensions if further information is needed.

MODEL

SHIP WEIGHT

CUBE

LIST PRICE

HRVT1524CK	1	0.8	\$67
HRVT1530CK	1	0.9	\$70
HRVT1536CK	1	1.1	\$76
HRVT1542CK	1	1.3	\$78
HRVT1548CK	2	1.5	\$82
HRVT1560CK	2	1.8	\$91
HRVT3024CK	3	1.4	\$67
HRVT3030CK	3	1.8	\$70
HRVT3036CK	3	2.1	\$76
HRVT3042CK	4	2.4	\$78
HRVT3048CK	5	2.8	\$82
HRVT3060CK	5	3.4	\$91

Coat Hooks

Package of six

HHPMC6

1

0.2

\$87

NOTES: Compatible with Accelerate® and Abound® panels. Coat hooks hang directly into slotted Abound panel frame.

! Black only. Ship 6 per package.



HOW TO SPECIFY

Select
Model Number

HRVT1524CK

DESCRIPTION

Abound® Anchor Bracket

Package of ten

HRABAB

5

0.08

\$85

NOTES: For use when panels need to be anchored to the floor such as high traffic areas or community spaces.

! Only available in Black (P).

! Only for use at the end of a wing panel.

SPECIFYING EXAMPLE: HRABAB.P

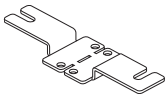

DESCRIPTION

Abound® Stability Foot

NOTES: Stabilizes bottom of panel from movement. Will not prohibit movement at top of panel.

! Only for use at the end of a wing panel.

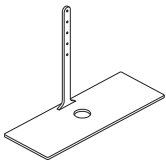

MODEL

SHIP WEIGHT

CUBE

LIST PRICE BY PAINT GRADE

P1

P2

HRFTAB

3

0.1

\$374

\$384

NOTES:

! The Anchor Bracket and Stability Foot are not intended to create a freestanding panel. Please follow Abound® stability standards.

! Attachment hardware for floor anchor not included.

HOW TO SPECIFY

Select
Model Number

Select
Paint Color

See page 395

HRFTAB.

T1



ABOUT® Gallery Panels — Wing

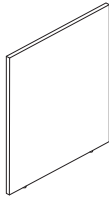

DESCRIPTION

Wing End of Run or Spanning End of Run

35”H x 27”W
35”H x 33”W
35”H x 39”W
35”H x 45”W
35”H x 51”W
35”H x 63”W
35”H x 75”W
42”H x 27”W
42”H x 33”W
42”H x 39”W
42”H x 45”W
42”H x 51”W
42”H x 63”W
42”H x 75”W
50”H x 27”W
50”H x 33”W
50”H x 39”W
50”H x 45”W
50”H x 51”W
50”H x 63”W
50”H x 75”W

MODEL

SHIP WEIGHT

CUBE

LIST PRICE BY LAMINATE GRADE

L1

L2

HRVG3527L	30.1	2.5	\$352	\$369
HRVG3533L	36.8	3.0	\$428	\$449
HRVG3539L	43.6	3.6	\$484	\$508
HRVG3545L	50.3	4.1	\$538	\$565
HRVG3551L	57.0	4.6	\$579	\$608
HRVG3563L	70.4	5.7	\$659	\$692
HRVG3575L	83.8	6.7	\$802	\$842
HRVG4227L	42.5	2.9	\$382	\$401
HRVG4233L	50.0	3.6	\$464	\$487
HRVG4239L	58.0	4.2	\$527	\$553
HRVG4245L	65.0	4.8	\$569	\$597
HRVG4251L	73.5	5.4	\$630	\$661
HRVG4263L	89.0	6.7	\$708	\$743
HRVG4275L	104.5	7.9	\$817	\$858
HRVG5027L	49.0	3.5	\$439	\$461
HRVG5033L	58.0	4.2	\$514	\$540
HRVG5039L	67.5	4.9	\$574	\$603
HRVG5045L	77.0	5.6	\$649	\$681
HRVG5051L	86.0	6.4	\$683	\$717
HRVG5063L	104.5	7.8	\$767	\$805
HRVG5075L	123.0	9.3	\$889	\$933

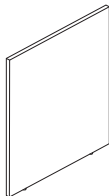

Wing Middle

35”H x 24”W
35”H x 30”W
35”H x 36”W
35”H x 42”W
35”H x 48”W
35”H x 60”W
42”H x 24”W
42”H x 30”W
42”H x 36”W
42”H x 42”W
42”H x 48”W
42”H x 60”W
50”H x 24”W
50”H x 30”W
50”H x 36”W
50”H x 42”W
50”H x 48”W
50”H x 60”W

HRVG3524L	26.8	2.4	\$334	\$350
HRVG3530L	33.5	2.9	\$407	\$427
HRVG3536L	40.2	3.3	\$453	\$475
HRVG3542L	46.9	3.8	\$507	\$532
HRVG3548L	53.6	4.4	\$560	\$588
HRVG3560L	67.0	5.4	\$645	\$677
HRVG4224L	38.5	2.6	\$362	\$380
HRVG4230L	46.0	3.3	\$441	\$463
HRVG4236L	54.0	3.9	\$492	\$517
HRVG4242L	62.0	4.5	\$550	\$577
HRVG4248L	69.5	5.1	\$592	\$622
HRVG4260L	85.0	6.3	\$690	\$724
HRVG5024L	44.5	3.1	\$417	\$438
HRVG5030L	53.0	3.8	\$490	\$514
HRVG5036L	63.0	4.6	\$541	\$568
HRVG5042L	72.0	5.3	\$605	\$635
HRVG5048L	81.5	6.0	\$666	\$699
HRVG5060L	100.0	7.5	\$752	\$790

NOTES:

- When specifying Wing End of Run panels, the Gallery Panels are 3” wider to allow for the panel to cover the width of the spine.
- Mid-configuration creates 1½” space between the system panels. This gap matches the thickness of the Gallery Panel.
- Wing End of Run widths of 51”, 63”, and 75”W can be used as spanning end of run configurations.
- Gallery Panels come standard with two adjustable leveling glides.
- Gallery Panels require connectors to attach to the spine of the panel. See connectors on page 446.
- Gallery Panels up to 60”W can specify vertical or horizontal woodgrain direction. Panels larger than 60”W will have horizontal woodgrain.

- ❗ Minimum panel length must be 50% of the Gallery Panel for stability.
- ❗ When system panel is higher than the Gallery Panel, system’s variable height trim kit must be specified to finish off the exposed frame.
- ❗ Standard Gallery Panels can only connect to standard panel frames. Use Gallery-to-Gallery Panels to connect Standard Gallery Panels to other Gallery Panels.
- ❗ Gallery Panels longer than 60”W require a floor or storage support.

HOW TO SPECIFY

<p>Select Model Number</p> <p>HRVG3527L</p>	<p>Select Laminate</p> <p>See page 395</p> <p>C</p>	<p>Select Edge</p> <p>See page 395</p> <p>C</p>	<p>Select Grain Direction</p> <p>VST Vertical Grain (not available on 63”W or wider) VLG Horizontal Grain and Solid Laminate only</p> <p>VST</p>	<p>Select Glide</p> <p>G Glide</p> <p>G</p>
--	--	--	---	--

ABOUND® Gallery Panels — Wing

OPEN MARKET



Icon Legend on page 19

WORKSTATIONS

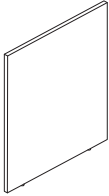

DESCRIPTION	MODEL	SHIP WEIGHT	CUBE	LIST PRICE BY LAMINATE GRADE	
				L1	L2
Spanning End of Run					
35"H x 51"W	HRVG3551L	57.0	4.6	\$579	\$608
35"H x 63"W	HRVG3563L	70.4	5.7	\$659	\$692
35"H x 75"W	HRVG3575L	83.8	6.7	\$802	\$842
42"H x 51"W	HRVG4251L	73.5	5.4	\$630	\$661
42"H x 63"W	HRVG4263L	89.0	6.7	\$708	\$743
42"H x 75"W	HRVG4275L	104.5	7.9	\$817	\$858
50"H x 51"W	HRVG5051L	86.0	6.4	\$683	\$717
50"H x 63"W	HRVG5063L	104.5	7.8	\$767	\$805
50"H x 75"W	HRVG5075L	123.0	9.3	\$889	\$933

NOTES:

- Gallery Panels come standard with two adjustable leveling guides.
- Gallery Panels require connectors to attach to the spine of the panel. See connectors on page 446.
- Gallery Panels up to 60"W can specify vertical or horizontal woodgrain direction. Panels larger than 60"W will have horizontal woodgrain.
- ! Minimum system panel length must be 50% of the Gallery Panel for stability.
- ! When system panel is higher than the Gallery Panel, system's variable height trim must be specified to finish off the exposed frame.
- ! Gallery Panels can only connect to standard panel frames; Gallery Panels cannot connect to each other.

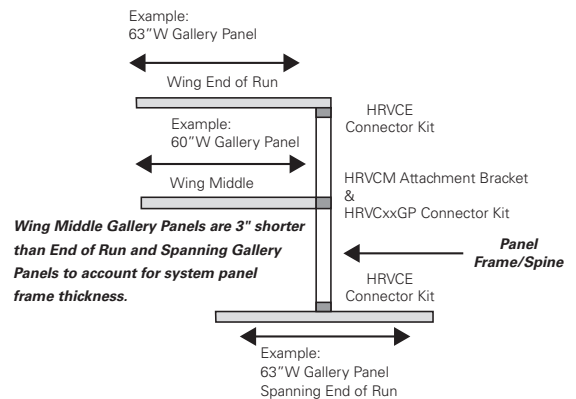

HOW TO SPECIFY

<p>Select Model Number</p> <p>HRVG3551L . C .</p>	<p>Select Laminate</p> <p>See page 395</p> <p>C .</p>	<p>Select Edge</p> <p>See page 395</p> <p>C .</p>	<p>Select Grain Direction</p> <p>VST Vertical Grain (not available on 63"W or wider) VLG Horizontal Grain and Solid Laminate only</p> <p>VST .</p>	<p>Select Glide</p> <p>G Glide</p> <p>G</p>
--	--	--	---	--



Icon Legend on page 19

Gallery Panels — Wing, Accepts Glass

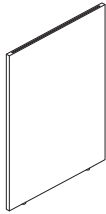

DESCRIPTION	MODEL	SHIP WEIGHT	CUBE	LIST PRICE BY LAMINATE GRADE	
				L1	L2
Wing End of Run or Spanning End of Run, Accepts Glass					
35”H x 27”W	HRVG3527LG	30.1	2.5	\$478	\$502
35”H x 33”W	HRVG3533LG	36.8	3.0	\$554	\$581
35”H x 39”W	HRVG3539LG	43.6	3.6	\$612	\$642
35”H x 45”W	HRVG3545LG	50.3	4.1	\$664	\$697
35”H x 51”W	HRVG3551LG	57.0	4.6	\$705	\$740
35”H x 63”W	HRVG3563LG	70.4	5.7	\$787	\$826
35”H x 75”W	HRVG3575LG	83.8	6.7	\$925	\$971
42”H x 27”W	HRVG4227LG	42.5	2.9	\$508	\$533
42”H x 33”W	HRVG4233LG	50.0	3.6	\$590	\$619
42”H x 39”W	HRVG4239LG	58.0	4.2	\$652	\$685
42”H x 45”W	HRVG4245LG	66.0	4.8	\$695	\$730
42”H x 51”W	HRVG4251LG	73.5	5.4	\$755	\$793
42”H x 63”W	HRVG4263LG	89.0	6.7	\$834	\$876
42”H x 75”W	HRVG4275LG	104.5	7.9	\$942	\$989
50”H x 27”W	HRVG5027LG	49.0	3.5	\$564	\$592
50”H x 33”W	HRVG5033LG	58.0	4.2	\$640	\$672
50”H x 39”W	HRVG5039LG	67.5	4.9	\$699	\$734
50”H x 45”W	HRVG5045LG	77.0	5.6	\$774	\$813
50”H x 51”W	HRVG5051LG	86.0	6.4	\$808	\$848
50”H x 63”W	HRVG5063LG	104.5	7.8	\$893	\$938
50”H x 75”W	HRVG5075LG	123.0	9.3	\$1015	\$1066

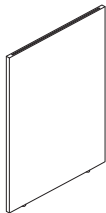

Wing Middle, Accepts Glass					
35”H x 24”W	HRVG3524LG	26.8	2.4	\$460	\$483
35”H x 30”W	HRVG3530LG	33.5	2.9	\$533	\$559
35”H x 36”W	HRVG3536LG	40.2	3.3	\$580	\$609
35”H x 42”W	HRVG3542LG	46.9	3.8	\$633	\$664
35”H x 48”W	HRVG3548LG	53.6	4.4	\$686	\$720
35”H x 60”W	HRVG3560LG	67.0	5.4	\$773	\$811
42”H x 24”W	HRVG4224LG	38.5	2.6	\$487	\$511
42”H x 30”W	HRVG4230LG	46.0	3.3	\$567	\$595
42”H x 36”W	HRVG4236LG	54.0	3.9	\$618	\$649
42”H x 42”W	HRVG4242LG	62.0	4.5	\$675	\$709
42”H x 48”W	HRVG4248LG	69.5	5.1	\$717	\$753
42”H x 60”W	HRVG4260LG	85.0	6.3	\$815	\$856
50”H x 24”W	HRVG5024LG	44.5	3.1	\$542	\$569
50”H x 30”W	HRVG5030LG	54.0	3.8	\$615	\$646
50”H x 36”W	HRVG5036LG	63.0	4.6	\$667	\$700
50”H x 42”W	HRVG5042LG	72.0	5.3	\$731	\$768
50”H x 48”W	HRVG5048LG	81.5	6.0	\$774	\$814
50”H x 60”W	HRVG5060LG	100.0	7.5	\$877	\$921

NOTES:

- When specifying Wing End of Run panels, the Gallery Panels are 3” wider to allow for the panel to cover the width of the spine.
- Mid-configuration creates 1 1/8” space between the system panels. This gap matches the thickness of the Gallery Panel.
- Wing End of Run widths of 51”, 63”, and 75”W can be used as spanning end of run configurations.
- Gallery Panels come standard with two adjustable leveling glides.
- Gallery Panels require connectors to attach to the spine of the panel. See connectors on page 446.
- Gallery Panels up to 60”W can specify vertical or horizontal woodgrain direction. Panels larger than 60”W will have horizontal woodgrain.

- ❗ Minimum panel length must be 50% of the Gallery Panel for stability.
- ❗ When system panel is higher than the Gallery Panel, system’s variable height trim kit must be specified to finish off the exposed frame.
- ❗ Standard Gallery Panels can only connect to standard panel frames. Use Gallery-to-Gallery Panels to connect Standard Gallery Panels to other Gallery Panels.
- ❗ Gallery Panels longer than 60”W require a floor or storage support.

HOW TO SPECIFY

<p>Select Model Number</p> <p>HRVG3527LG</p>	<p>Select Laminate</p> <p>See page 395</p> <p>C</p>	<p>Select Edge</p> <p>See page 395</p> <p>C</p>	<p>Select Grain Direction</p> <p>VST Vertical Grain (not available on 63”W or wider) VLG Horizontal Grain and Solid Laminate only</p> <p>VST</p>	<p>Select Glide</p> <p>G Glide</p> <p>G</p>
---	--	--	---	--

ABOUND[®] Gallery Panels — Wing, Accepts Glass

OPEN MARKET



Icon Legend on page 19

WORKSTATIONS

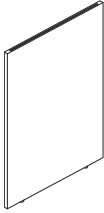

DESCRIPTION	MODEL	SHIP WEIGHT	CUBE	LIST PRICE BY LAMINATE GRADE	
				L1	L2
Spanning End of Run w/Glass					
35”H x 51”W	HRVG3551LG	57.0	4.6	\$705	\$740
35”H x 63”W	HRVG3563LG	70.4	5.7	\$787	\$826
35”H x 75”W	HRVG3575LG	83.5	6.7	\$925	\$971
42”H x 51”W	HRVG4251LG	73.5	5.4	\$755	\$793
42”H x 63”W	HRVG4263LG	89.0	6.7	\$834	\$876
42”H x 75”W	HRVG4275LG	104.5	7.9	\$942	\$989
50”H x 51”W	HRVG5051LG	86.0	6.4	\$808	\$848
50”H x 63”W	HRVG5063LG	104.5	7.8	\$893	\$938
50”H x 75”W	HRVG5075LG	123.0	9.3	\$1015	\$1066

NOTES:

- Gallery Panels come standard with two adjustable leveling guides.
- Gallery Panels require connectors to attach to the spine of the panel. See connectors on page 446.
- Gallery Panels are notched to accept Frameless Glass. Frameless Glass sold separately. See page 445.
- Gallery Panels up to 60”W can specify vertical or horizontal woodgrain direction. Panels larger than 60”W will have horizontal woodgrain.
- ! Minimum system panel length must be 50% of the Gallery Panel for stability.
- ! When system panel is higher than the Gallery Panel, system’s variable height trim must be specified to finish off the exposed frame.
- ! Gallery Panels can only connect to standard panel frames; Gallery Panels cannot connect to each other.

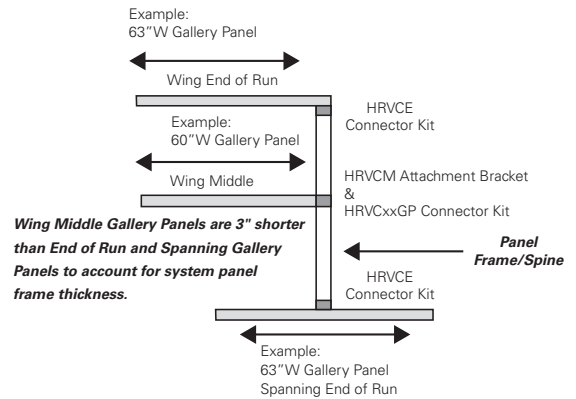

HOW TO SPECIFY

<p>Select Model Number</p> <p>HRVG3551LG</p>	<p>Select Laminate</p> <p>See page 395</p> <p>C</p>	<p>Select Edge</p> <p>See page 395</p> <p>C</p>	<p>Select Grain Direction</p> <p>VST Vertical Grain (not available on 63”W or wider)</p> <p>VLG Horizontal Grain and Solid Laminate only</p> <p>VST</p>	<p>Select Glide</p> <p>G Glide</p> <p>G</p>
--	---	---	---	---



Icon Legend on page 19

ABOUND[®] Gallery Glass

	DESCRIPTION	MODEL	SHIP WEIGHT	CUBE	CLEAR GLASS	FROSTED GLASS
	7 1/2" H Gallery Glass, Wing, End of Run					
	For 27" D Panels	SPLH-ABND-GALGLSS.M482172	9.0	0.7	\$374	\$409
	For 33" D Panels	SPLH-ABND-GALGLSS.M482174	10.5	0.9	\$396	\$431
	For 39" D Panels	SPLH-ABND-GALGLSS.M482176	12.0	1.1	\$453	\$488
	For 45" D Panels	SPLH-ABND-GALGLSS.M482178	13.0	1.3	\$479	\$514
	For 51" D Panels	SPLH-ABND-GALGLSS.M482180	14.5	1.5	\$529	\$564
	For 63" D Panels	SPLH-ABND-GALGLSS.M482182	17.0	1.8	\$622	\$657
	7 1/2" H Gallery Glass, Middle					
	For 24" D Panels	SPLH-ABND-GALGLSS.M482171	8.0	0.7	\$365	\$400
	For 30" D Panels	SPLH-ABND-GALGLSS.M482173	10.0	0.8	\$385	\$420
	For 36" D Panels	SPLH-ABND-GALGLSS.M482175	11.0	1.0	\$405	\$440
	For 42" D Panels	SPLH-ABND-GALGLSS.M482177	12.5	1.2	\$465	\$500
	For 48" D Panels	SPLH-ABND-GALGLSS.M482179	14.0	1.4	\$509	\$544
	For 60" D Panels	SPLH-ABND-GALGLSS.M482181	16.0	1.7	\$612	\$647
NOTES: Compatible with Gallery-to-Gallery connections, see page 448-451.						
	7 1/2" H Gallery Glass, Spanning End of Run					
	For 51" D Panels	SPLH-ABND-GALGLSS.M482180	14.5	1.5	\$529	\$564
	For 63" D Panels	SPLH-ABND-GALGLSS.M482182	17.0	1.8	\$622	\$657
	For 75" D Panels	SPLH-ABND-GALGLSS.M482183	19.5	2.2	\$735	\$770

NOTES:

- Gallery Panels are 3" wider than corresponding glass to allow for proper fit and function.
- Glass is inset 1 1/2" from end of Standard Gallery Panels. Gallery-to-Gallery Panels have 1/2" glass inset.
- ❗ Cannot hang or stack on top of Frameless Glass.
- ❗ Frameless Glass can only be used on the top of Gallery Panels. Glass integrates into notch cutout in the top of the panel.

HOW TO SPECIFY

<p>Select Model Number</p>	<p>Select Glass</p> <p>Q Clear Glass R Frosted Glass</p>
<p>S P L H - A B N D - G A L G L S S . M 4 8 2 1 7 1 .</p>	<p>Q</p>

ABOUND[®] Gallery Connector Kits

OPEN MARKET



Icon Legend on page 19

WORKSTATIONS

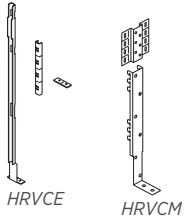

DESCRIPTION

Gallery Panel Connectors
Spanning End of Run and L Connector
Wing Middle Attachment Brackets

MODEL

SHIP WEIGHT **CUBE**

LIST PRICE BY PAINT GRADE

P1 **P2**

HRVCE	0.83	0.1	\$75	\$82
HRVCM	0.62	0.1	\$86	\$95



Gallery Connector Kits

35"
42"
50"
65"

HRVC35GP	1.0	0.3	\$170	\$183
HRVC42GP	1.5	0.4	\$190	\$205
HRVC50GP	1.5	0.5	\$200	\$215
HRVC65GP	2.0	0.6	\$232	\$249

DESCRIPTION

Gallery Panel-to-Storage Kits
Laminate Storage Ganging Kit
Metal Storage Ganging Kit

MODEL

SHIP WEIGHT

CUBE

LIST PRICE

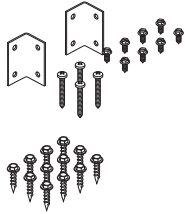

HRVGLSK	0.1	0.1	\$41
HRVGMSK	0.1	0.1	\$9

NOTES:

- HRVCE is used in L and spanning (T) end of run applications.
- Wing Middle Connector Kits accommodate both single-sided and dual-sided applications.
- For more rigidity, the Gallery Panel can be tied to a storage or a non-adjustable surface. Use HRVGLSK for laminate or HRVGMSK for metal storage.
- HAT bases can be tied to Gallery Panels using HAT-to-Gallery brackets on page 452.
- ! Wing Middle Connector Kits must be used in any Wing Middle application in conjunction with model HRVCM.
- ! Wing Middle Connector Kits are required for Wing Middle applications and are used only with Wing Middle Gallery Panels.
- ! Gallery Panels can only connect to standard panel frames; Gallery Panels cannot connect to each other.
- ! See Gallery Panel and Connector illustration on pages 442 and 444 for placement and application.

HOW TO SPECIFY

<p>Select Model Number</p> <p>HRVC42GP</p>	<p>Select Paint Color</p> <p>See page 395</p> <p>T1</p>
---	--

<p>Select Model Number</p> <p>HRVGMSK</p>
--



ABOUND[®] Gallery Panel Tackboards

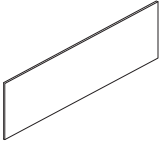

DESCRIPTION	MODEL	SHIP WEIGHT	CUBE	LIST PRICE BY FABRIC GRADE								
				AA	A	B	C	D	E	F	G	
Gallery Panel Tackboards												
36"W x 11"H	HRVTB11	7	1.1	\$254	\$259	\$262	\$265	\$268	\$273	\$278	\$283	
36"W x 18½"H	HRVTB18	10	1.8	\$298	\$303	\$306	\$309	\$312	\$317	\$322	\$327	

NOTES:

- Tackboard attaches to Gallery Panel by screwing painted metal frame onto Gallery Panel surface. Fabric insert attaches to painted metal frame with hook and loop.
- Attachment hardware for Tackboard is provided.
- ! No template is provided for placement and leveling of Tackboard.

HOW TO SPECIFY

<p>Select Model Number</p> <p>HRVTB11</p>	<p>Select Fabric</p> <p>See pages 396-397</p> <p>APN11</p>
--	---

ABOUND[®] Gallery-to-Gallery Connections

OPEN MARKET



Icon Legend on page 19

WORKSTATIONS

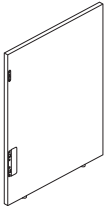

DESCRIPTION	MODEL	SHIP WEIGHT	CUBE	LIST PRICE BY LAMINATE GRADE	
				L1	L2
L-Connections, Right Hand					
35"H x 18"W	HRVG3518GGR	23.6	2.0	\$554	\$579
35"H x 24"W	HRVG3524GGR	30.5	2.6	\$598	\$625
35"H x 30"W	HRVG3530GGR	37.4	3.1	\$645	\$674
35"H x 36"W	HRVG3536GGR	44.3	3.6	\$692	\$723
35"H x 42"W	HRVG3542GGR	51.1	4.1	\$743	\$777
35"H x 48"W	HRVG3548GGR	58.0	4.7	\$798	\$835
35"H x 60"W	HRVG3560GGR	71.8	5.7	\$857	\$897
42"H x 18"W	HRVG4218GGR	28.5	2.4	\$576	\$602
42"H x 24"W	HRVG4224GGR	36.9	3.0	\$621	\$649
42"H x 30"W	HRVG4230GGR	45.3	3.7	\$670	\$700
42"H x 36"W	HRVG4236GGR	53.7	4.3	\$723	\$756
42"H x 42"W	HRVG4242GGR	62.1	4.9	\$782	\$818
42"H x 48"W	HRVG4248GGR	70.5	5.6	\$844	\$883
42"H x 60"W	HRVG4260GGR	87.3	6.8	\$907	\$949
50"H x 18"W	HRVG5018GGR	33.4	2.8	\$621	\$649
50"H x 24"W	HRVG5024GGR	43.3	3.5	\$670	\$700
50"H x 30"W	HRVG5030GGR	53.2	4.3	\$723	\$756
50"H x 36"W	HRVG5036GGR	63.1	5.0	\$777	\$813
50"H x 42"W	HRVG5042GGR	73.1	5.7	\$834	\$872
50"H x 48"W	HRVG5048GGR	83.0	6.5	\$896	\$938
50"H x 60"W	HRVG5060GGR	102.8	7.9	\$963	\$1008
L-Connections, Right Hand, Accepts Glass					
35"H x 18"W	HRVG3518GGRG	23.6	2.0	\$640	\$669
35"H x 24"W	HRVG3524GGRG	30.5	2.6	\$691	\$722
35"H x 30"W	HRVG3530GGRG	37.4	3.1	\$746	\$780
35"H x 36"W	HRVG3536GGRG	44.3	3.6	\$802	\$839
35"H x 42"W	HRVG3542GGRG	51.1	4.1	\$861	\$901
35"H x 48"W	HRVG3548GGRG	58.0	4.7	\$925	\$968
35"H x 60"W	HRVG3560GGRG	71.8	5.7	\$995	\$1041
42"H x 18"W	HRVG4218GGRG	28.4	2.4	\$655	\$685
42"H x 24"W	HRVG4224GGRG	36.9	3.0	\$708	\$740
42"H x 30"W	HRVG4230GGRG	45.3	3.7	\$765	\$800
42"H x 36"W	HRVG4236GGRG	53.7	4.3	\$826	\$864
42"H x 42"W	HRVG4242GGRG	62.1	4.9	\$893	\$934
42"H x 48"W	HRVG4248GGRG	70.5	5.6	\$965	\$1010
42"H x 60"W	HRVG4260GGRG	87.3	6.8	\$1038	\$1087
50"H x 18"W	HRVG5018GGRG	33.4	2.8	\$691	\$722
50"H x 24"W	HRVG5024GGRG	43.3	3.5	\$746	\$780
50"H x 30"W	HRVG5030GGRG	53.2	4.3	\$806	\$843
50"H x 36"W	HRVG5036GGRG	63.1	5.0	\$866	\$906
50"H x 42"W	HRVG5042GGRG	73.1	5.7	\$930	\$973
50"H x 48"W	HRVG5048GGRG	83.0	6.5	\$1001	\$1048
50"H x 60"W	HRVG5060GGRG	102.8	7.9	\$1076	\$1126

NOTES:

- Gallery-to-Gallery Panels connect to other Gallery Panels and are available in L-, T-, and Non-symmetrical T-configurations.
- When specifying Gallery-to-Gallery Panels, the installation template (HRVGTGG) is required. The recommendation is one template for every 30 panels. Templates are reusable.
- Gallery-to-Gallery Panels must be of equal or lower height than the Standard Gallery Panel attached. The Gallery-to-Gallery Panel cannot be taller than the adjacent panel. If this is needed, please reach out to Tailored Solutions for a custom solution.
- Made of 1 1/8" board with HPL laminate.
- Can be specified with matching or contrasting edge.
- Edgeband is 2mm ABS.
- Available in woodgrain and solid laminates.
- Woodgrain laminates can be specified with vertical grain up to 48"W. Horizontal grain is available on all sizes.
- Gallery-to-Gallery Panel widths are available in 18", 24", 30", 36", 42", 48", and 60"W.
- Gallery Panels offer 2 1/2" leveling capability.
- Overall heights line up with adjacent panel.
- Gallery-to-Gallery Panels cap over Standard Gallery Panels and are oversized by 1 1/8" to maintain true interior dimensions.
- Available with or without the integrated glass option.
- Glass specified separately, see 7 1/2"H Gallery Glass on page 445.
- Gallery Panels for use with glass have separate model numbers.
- Gallery-to-Gallery Panels are secured with an inset flat bracket under a painted metal cover.
- L-panels are handed.

HOW TO SPECIFY

<p>Select Model Number</p> <p>HRVG4236GGR</p>	<p>Select Laminate</p> <p>See page 395</p> <p>H</p>	<p>Select Edge</p> <p>See page 395</p> <p>H</p>	<p>Select Grain Direction</p> <p>VLG Horizontal Grain and Solid Laminate only VST Vertical Grain</p> <p>VLG</p>	<p>Select Paint Color</p> <p>See page 395</p> <p>P8T</p>	<p>Select Glide</p> <p>G Glide</p> <p>G</p>
--	--	--	--	---	--



Icon Legend on page 19

ABOUT® Gallery-to-Gallery Connections

WORKSTATIONS

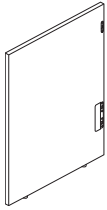

DESCRIPTION	MODEL	SHIP WEIGHT	CUBE	LIST PRICE BY LAMINATE GRADE	
				L1	L2
L-Connections, Left Hand					
35"H x 18"W	HRVG3518GGL	23.6	2.0	\$554	\$579
35"H x 24"W	HRVG3524GGL	30.5	2.6	\$598	\$625
35"H x 30"W	HRVG3530GGL	37.4	3.1	\$645	\$674
35"H x 36"W	HRVG3536GGL	44.3	3.6	\$692	\$723
35"H x 42"W	HRVG3542GGL	51.1	4.1	\$743	\$777
35"H x 48"W	HRVG3548GGL	58.0	4.7	\$798	\$835
35"H x 60"W	HRVG3560GGL	71.8	5.7	\$857	\$897
42"H x 18"W	HRVG4218GGL	28.5	2.4	\$576	\$602
42"H x 24"W	HRVG4224GGL	36.9	3.0	\$621	\$649
42"H x 30"W	HRVG4230GGL	45.3	3.7	\$670	\$700
42"H x 36"W	HRVG4236GGL	53.7	4.3	\$723	\$756
42"H x 42"W	HRVG4242GGL	62.1	4.9	\$782	\$818
42"H x 48"W	HRVG4248GGL	70.5	5.6	\$844	\$883
42"H x 60"W	HRVG4260GGL	87.3	6.8	\$907	\$949
50"H x 18"W	HRVG5018GGL	33.4	2.8	\$621	\$649
50"H x 24"W	HRVG5024GGL	43.3	3.5	\$670	\$700
50"H x 30"W	HRVG5030GGL	53.2	4.3	\$723	\$756
50"H x 36"W	HRVG5036GGL	63.1	5.0	\$777	\$813
50"H x 42"W	HRVG5042GGL	73.1	5.7	\$834	\$872
50"H x 48"W	HRVG5048GGL	83.0	6.5	\$896	\$938
50"H x 60"W	HRVG5060GGL	102.8	7.9	\$963	\$1008



L-Connections, Left Hand, Accepts Glass					
35"H x 18"W	HRVG3518GGGL	23.6	2.0	\$640	\$669
35"H x 24"W	HRVG3524GGGL	30.5	2.6	\$691	\$722
35"H x 30"W	HRVG3530GGGL	37.4	3.1	\$746	\$780
35"H x 36"W	HRVG3536GGGL	44.3	3.6	\$802	\$839
35"H x 42"W	HRVG3542GGGL	51.1	4.1	\$861	\$901
35"H x 48"W	HRVG3548GGGL	58.0	4.7	\$925	\$968
35"H x 60"W	HRVG3560GGGL	71.8	5.7	\$995	\$1041
42"H x 18"W	HRVG4218GGGL	28.4	2.4	\$655	\$685
42"H x 24"W	HRVG4224GGGL	36.9	3.0	\$708	\$740
42"H x 30"W	HRVG4230GGGL	45.3	3.7	\$765	\$800
42"H x 36"W	HRVG4236GGGL	53.7	4.3	\$826	\$864
42"H x 42"W	HRVG4242GGGL	62.1	4.9	\$893	\$934
42"H x 48"W	HRVG4248GGGL	70.5	5.6	\$965	\$1010
42"H x 60"W	HRVG4260GGGL	87.3	6.8	\$1038	\$1087
50"H x 18"W	HRVG5018GGGL	33.4	2.8	\$691	\$722
50"H x 24"W	HRVG5024GGGL	43.3	3.5	\$746	\$780
50"H x 30"W	HRVG5030GGGL	53.2	4.3	\$806	\$843
50"H x 36"W	HRVG5036GGGL	63.1	5.0	\$866	\$906
50"H x 42"W	HRVG5042GGGL	73.1	5.7	\$930	\$973
50"H x 48"W	HRVG5048GGGL	83.0	6.5	\$1001	\$1048
50"H x 60"W	HRVG5060GGGL	102.8	7.9	\$1076	\$1126

NOTES:

- Gallery-to-Gallery Panels connect to other Gallery Panels and are available in L-, T-, and Non-symmetrical T-configurations.
- When specifying Gallery-to-Gallery Panels, the installation template (HRVGTGG) is required. The recommendation is one template for every 30 panels. Templates are reusable.
- Gallery-to-Gallery Panels must be of equal or lower height than the Standard Gallery Panel attached. The Gallery-to-Gallery Panel cannot be taller than the adjacent panel. If this is needed, please reach out to Tailored Solutions for a custom solution.
- Made of 1/8" board with HPL laminate.
- Can be specified with matching or contrasting edge.
- Edgeband is 2mm ABS.
- Available in woodgrain and solid laminates.
- Woodgrain laminates can be specified with vertical grain up to 48"W. Horizontal grain is available on all sizes.
- Gallery-to-Gallery Panel widths are available in 18", 24", 30", 36", 42", 48", and 60"W.
- Gallery Panels offer 2 1/2" leveling capability.
- Overall heights line up with adjacent panel.
- Gallery-to-Gallery Panels cap over Standard Gallery Panels and are oversized by 1/8" to maintain true interior dimensions.
- Available with or without the integrated glass option.
- Glass specified separately, see 7 1/2" H Gallery Glass on page 445.
- Gallery Panels for use with glass have separate model numbers.
- Gallery-to-Gallery Panels are secured with an inset flat bracket under a painted metal cover.
- L-panels are handed.

HOW TO SPECIFY

<p>Select Model Number</p> <p>HRVG4236GGGLG</p>	<p>Select Laminate</p> <p>See page 395</p> <p>H</p>	<p>Select Edge</p> <p>See page 395</p> <p>H</p>	<p>Select Grain Direction</p> <p>VLG Horizontal Grain and Solid Laminate only VST Vertical Grain</p> <p>VLG</p>	<p>Select Paint Color</p> <p>See page 395</p> <p>P8T</p>	<p>Select Glide</p> <p>G Glide</p> <p>G</p>
--	--	--	--	---	--

ABOUND[®] Gallery-to-Gallery Connections

OPEN MARKET



Icon Legend on page 19

WORKSTATIONS

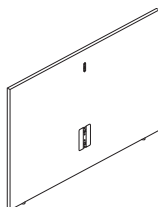

DESCRIPTION	MODEL	SHIP WEIGHT	CUBE	LIST PRICE BY LAMINATE GRADE	
				L1	L2
T-Connections					
35"H x 18"W	HRVG3518GGT	23.6	2.0	\$636	\$662
35"H x 36"W	HRVG3536GGT	44.3	3.6	\$780	\$813
35"H x 42"W	HRVG3542GGT	51.1	4.1	\$834	\$870
35"H x 48"W	HRVG3548GGT	58.0	4.7	\$891	\$930
35"H x 60"W	HRVG3560GGT	71.8	5.7	\$953	\$995
35"H x 72"W	HRVG3572GGT	85.5	6.8	\$1030	\$1075
42"H x 18"W	HRVG4218GGT	28.5	2.4	\$658	\$685
42"H x 36"W	HRVG4236GGT	53.7	4.3	\$812	\$847
42"H x 42"W	HRVG4242GGT	62.1	4.9	\$873	\$911
42"H x 48"W	HRVG4248GGT	70.5	5.6	\$940	\$981
42"H x 60"W	HRVG4260GGT	87.3	6.8	\$1006	\$1050
42"H x 72"W	HRVG4272GGT	104.1	8.1	\$1100	\$1149
50"H x 18"W	HRVG5018GGT	33.4	2.8	\$705	\$734
50"H x 36"W	HRVG5036GGT	63.1	5.0	\$871	\$909
50"H x 42"W	HRVG5042GGT	73.1	5.7	\$937	\$978
50"H x 48"W	HRVG5048GGT	83.0	6.5	\$1008	\$1052
50"H x 60"W	HRVG5060GGT	102.8	7.9	\$1086	\$1134
50"H x 72"W	HRVG5072GGT	122.7	9.4	\$1171	\$1223

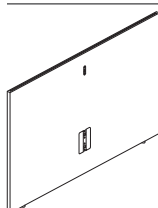

DESCRIPTION	MODEL	SHIP WEIGHT	CUBE	LIST PRICE BY LAMINATE GRADE	
				L1	L2
T-Connections, Accepts Glass					
35"H x 18"W	HRVG3518GGTG	23.6	2.0	\$726	\$756
35"H x 36"W	HRVG3536GGTG	44.3	3.6	\$895	\$934
35"H x 42"W	HRVG3542GGTG	51.1	4.1	\$957	\$999
35"H x 48"W	HRVG3548GGTG	58.0	4.7	\$1025	\$1070
35"H x 60"W	HRVG3560GGTG	71.8	5.7	\$1098	\$1147
35"H x 72"W	HRVG3572GGTG	85.5	6.8	\$1177	\$1230
42"H x 18"W	HRVG4218GGTG	28.5	2.4	\$742	\$773
42"H x 36"W	HRVG4236GGTG	53.7	4.3	\$920	\$960
42"H x 42"W	HRVG4242GGTG	62.1	4.9	\$990	\$1033
42"H x 48"W	HRVG4248GGTG	70.5	5.6	\$1067	\$1114
42"H x 60"W	HRVG4260GGTG	87.3	6.8	\$1144	\$1195
42"H x 72"W	HRVG4272GGTG	104.1	8.1	\$1238	\$1294
50"H x 18"W	HRVG5018GGTG	33.4	2.8	\$778	\$811
50"H x 36"W	HRVG5036GGTG	63.1	5.0	\$969	\$1011
50"H x 42"W	HRVG5042GGTG	73.1	5.7	\$1044	\$1090
50"H x 48"W	HRVG5048GGTG	83.0	6.5	\$1125	\$1175
50"H x 60"W	HRVG5060GGTG	102.8	7.9	\$1212	\$1266
50"H x 72"W	HRVG5072GGTG	122.7	9.4	\$1308	\$1367

NOTES:

- Gallery-to-Gallery Panels connect to other Gallery Panels and are available in L-, T-, and Non-symmetrical T-configurations.
- When specifying Gallery-to-Gallery Panels, the installation template (HRVGTGG) is required. The recommendation is one template for every 30 panels. Templates are reusable.
- Gallery-to-Gallery Panels must be of equal or lower height than the Standard Gallery Panel attached. The Gallery-to-Gallery Panel cannot be taller than the adjacent panel. If this is needed, please reach out to Tailored Solutions for a custom solution.
- Made of 1 1/8" board with HPL laminate.
- Can be specified with matching or contrasting edge.
- Edgeband is 2mm ABS.
- Available in woodgrain and solid laminates.
- Non-symmetric T-panels vary in size on either side of the adjacent panel.
- Woodgrain laminates can be specified with vertical grain up to 48"W. Horizontal grain is available on all sizes.
- Gallery-to-Gallery Panel widths are available in 18", 24", 30", 36", 42", 48", and 60"W.
- Gallery Panels offer 2 1/2" leveling capability.
- Overall heights line up with adjacent panel.
- Gallery-to-Gallery Panels cap over Standard Gallery Panels and are oversized by 1 1/8" to maintain true interior dimensions.
- Available with or without the integrated glass option.
- Glass specified separately, see 7 1/2"H Gallery Glass on page 445.
- Gallery Panels for use with glass have separate model numbers.
- Gallery-to-Gallery Panels are secured with an inset flat bracket under a painted metal cover.

HOW TO SPECIFY

<p>Select Model Number</p> <p>HRVG4242GGT</p>	<p>Select Laminate</p> <p>See page 395</p> <p>H</p>	<p>Select Edge</p> <p>See page 395</p> <p>H</p>	<p>Select Grain Direction</p> <p>VLG Horizontal Grain and Solid Laminate only VST Vertical Grain</p> <p>VLG</p>	<p>Select Paint Color</p> <p>See page 395</p> <p>P8T</p>	<p>Select Glide</p> <p>G Glide</p> <p>G</p>
--	--	--	--	---	--



ABOUT® Gallery-to-Gallery Connections

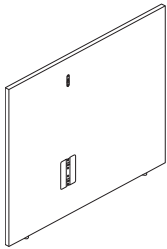

DESCRIPTION	MODEL	SHIP WEIGHT	CUBE	LIST PRICE BY LAMINATE GRADE	
				L1	L2
Non-Symmetrical Connections					
35"H x 18"W/24"W	HRVG351824GGNS	51.1	4.1	\$834	\$870
35"H x 24"W/18"W	HRVG352418GGNS	51.1	4.1	\$834	\$870
35"H x 18"W/30"W	HRVG351830GGNS	58.0	4.7	\$891	\$930
35"H x 30"W/18"W	HRVG353018GGNS	58.0	4.7	\$891	\$930
35"H x 24"W/30"W	HRVG352430GGNS	64.9	5.2	\$923	\$963
35"H x 30"W/24"W	HRVG353024GGNS	64.9	5.2	\$923	\$963
42"H x 18"W/24"W	HRVG421824GGNS	62.1	4.9	\$873	\$911
42"H x 24"W/18"W	HRVG422418GGNS	62.1	4.9	\$873	\$911
42"H x 18"W/30"W	HRVG421830GGNS	70.5	5.6	\$940	\$981
42"H x 30"W/18"W	HRVG423018GGNS	70.5	5.6	\$940	\$981
42"H x 24"W/30"W	HRVG422430GGNS	78.9	6.2	\$973	\$1016
42"H x 30"W/24"W	HRVG423024GGNS	78.9	6.2	\$973	\$1016
50"H x 18"W/24"W	HRVG501824GGNS	73.1	5.7	\$937	\$978
50"H x 24"W/18"W	HRVG502418GGNS	73.1	5.7	\$937	\$978
50"H x 18"W/30"W	HRVG501830GGNS	83.0	6.5	\$1008	\$1052
50"H x 30"W/18"W	HRVG503018GGNS	83.0	6.5	\$1008	\$1052
50"H x 24"W/30"W	HRVG502430GGNS	92.9	7.2	\$1048	\$1094
50"H x 30"W/24"W	HRVG503024GGNS	92.9	7.2	\$1048	\$1094

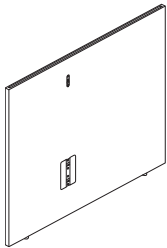

DESCRIPTION	MODEL	SHIP WEIGHT	CUBE	LIST PRICE BY LAMINATE GRADE	
				L1	L2
Non-Symmetrical Connections, Accepts Glass					
35"H x 18"W/24"W	HRVG351824GGNSG	51.1	4.1	\$957	\$999
35"H x 24"W/18"W	HRVG352418GGNSG	51.1	4.1	\$957	\$999
35"H x 18"W/30"W	HRVG351830GGNSG	58.0	4.7	\$1025	\$1070
35"H x 30"W/18"W	HRVG353018GGNSG	58.0	4.7	\$1025	\$1070
35"H x 24"W/30"W	HRVG352430GGNSG	64.9	5.2	\$1062	\$1109
35"H x 30"W/24"W	HRVG353024GGNSG	64.9	5.2	\$1062	\$1109
42"H x 18"W/24"W	HRVG421824GGNSG	62.1	4.9	\$990	\$1033
42"H x 24"W/18"W	HRVG422418GGNSG	62.1	4.9	\$990	\$1033
42"H x 18"W/30"W	HRVG421830GGNSG	70.5	5.6	\$1067	\$1114
42"H x 30"W/18"W	HRVG423018GGNSG	70.5	5.6	\$1067	\$1114
42"H x 24"W/30"W	HRVG422430GGNSG	78.9	6.2	\$1105	\$1154
42"H x 30"W/24"W	HRVG423024GGNSG	78.9	6.2	\$1105	\$1154
50"H x 18"W/24"W	HRVG501824GGNSG	73.1	5.7	\$1044	\$1090
50"H x 24"W/18"W	HRVG502418GGNSG	73.1	5.7	\$1044	\$1090
50"H x 18"W/30"W	HRVG501830GGNSG	83.0	6.5	\$1125	\$1175
50"H x 30"W/18"W	HRVG503018GGNSG	83.0	6.5	\$1125	\$1175
50"H x 24"W/30"W	HRVG502430GGNSG	92.9	7.2	\$1169	\$1221
50"H x 30"W/24"W	HRVG503024GGNSG	92.9	7.2	\$1169	\$1221

NOTES:

- Gallery-to-Gallery Panels connect to other Gallery Panels and are available in L-, T-, and Non-symmetrical T-configurations.
- When specifying Gallery-to-Gallery Panels, the installation template (HRVGTGG) is required. The recommendation is one template for every 30 panels. Templates are reusable.
- Gallery-to-Gallery Panels must be of equal or lower height than the Standard Gallery Panel attached. The Gallery-to-Gallery Panel cannot be taller than the adjacent panel. If this is needed, please reach out to Tailored Solutions for a custom solution.
- Made of 1 1/8" board with HPL laminate.
- Can be specified with matching or contrasting edge.
- Edgeband is 2mm ABS.
- Available in woodgrain and solid laminates.
- Non-symmetric T-panels vary in size on either side of the adjacent panel.
- Woodgrain laminates can be specified with vertical grain up to 48"W. Horizontal grain is available on all sizes.
- Gallery-to-Gallery Panel widths are available in 18", 24", 30", 36", 50", 48", and 60"W.
- Gallery Panels offer 2 1/2" leveling capability.
- Overall heights line up with adjacent panel.
- Gallery-to-Gallery Panels cap over Standard Gallery Panels and are oversized by 1/8" to maintain true interior dimensions.
- Available with or without the integrated glass option.
- Glass specified separately, see 7 1/2"H Gallery Glass on page 445.
- Gallery Panels for use with glass have separate model numbers.
- Gallery-to-Gallery Panels are secured with an inset flat bracket under a painted metal cover.

HOW TO SPECIFY

<p>Select Model Number</p> <p>HRVG421830GGNS</p>	<p>Select Laminate</p> <p>See page 395</p> <p>H</p>	<p>Select Edge</p> <p>See page 395</p> <p>H</p>	<p>Select Grain Direction</p> <p>VLG Horizontal Grain and Solid Laminate only VST Vertical Grain</p> <p>VLG</p>	<p>Select Paint Color</p> <p>See page 395</p> <p>P8T</p>	<p>Select Glide</p> <p>G Glide</p> <p>G</p>
---	--	--	--	---	--

ABOUND® Height Adjustable Tie-In Brackets

OPEN MARKET



Icon Legend on page 19

WORKSTATIONS

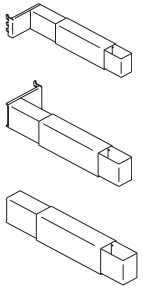
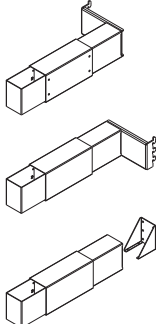
	DESCRIPTION	MODEL	SHIP WEIGHT	CUBE	LIST PRICE BY PAINT GRADE		
					P1	P2	P3
	Rectangle Leg, T-Foot Brackets HAT to Panel, Left Hand	HHALRETL	4.0	0.2	\$152	\$167	\$175
	HAT to Panel, Right Hand	HHALRETR	4.0	0.2	\$152	\$167	\$175
	HAT to Gallery Panel	HHALRETG	3.5	0.2	\$152	\$167	\$175
	Rectangle Leg, C-Foot Brackets HAT to Panel, Left Hand	HHALRECL	4.0	0.2	\$152	\$167	\$175
	HAT to Panel, Right Hand	HHALRECR	4.0	0.2	\$152	\$167	\$175
	HAT to Gallery Panel ⓘ Not compatible with Coordinate™ model HHABETA2S2L.	HHALRECG	3.5	0.2	\$152	\$167	\$175
	DESCRIPTION	MODEL	SHIP WEIGHT	CUBE	LIST PRICE		
	Gallery-to-Gallery Template	HRVGTGG	1.1	0.5	\$55		
	HAT-to-Gallery Template	HHALGPT	1.1	0.1	\$55		

NOTES:

- Tie-in brackets are used to tie a height adjustable table to either a Standard Panel or Gallery Panel for added rigidity.
- Bracket ties into the approach side of the height adjustable worksurface — this removes the need for a wing panel.
- Can be used as a value engineering option to replace wing panels.
- Available in all paint colors to match panel trim or coordinating colors to the height adjustable base.
- Brackets telescope to account for 24" and 30" deep worksurfaces and screen attachments.

ⓘ Brackets must be used on a return panel, not a spine wall, except if stations are back-to-back on a spine wall and a tie-in bracket is used at a minimum every 96".

ⓘ C-legs with a 30"D worksurface and a screen must be specified with T-leg brackets.

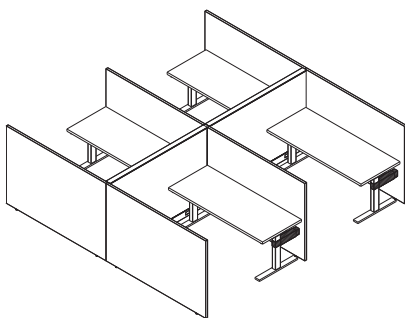

SINGLE BRACKET

Systems Application

- Max Height (with Glass): 65"H
- Max Width: 96"; tops greater than 72"W **will not align**.

Gallery Panel Application

- Max Height (with Glass): 65"H
- Max Width: 75"; no top size restrictions.

DUAL-SIDED PANEL BENCH

Systems Application

- Max Height (with Glass): 65"H
- Bracket needed every 96" on both sides; tops greater than 72"W **will not align**.

Gallery Panel Application

- Max Height (with Glass): 65"H
- Bracket Needed: Single Panel (75") with brackets on each leg (same height).

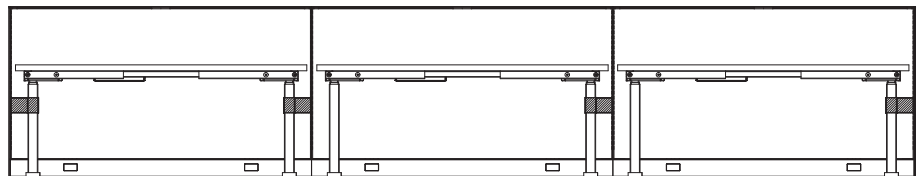

ⓘ Overhead storage cannot be used without return panels.

HOW TO SPECIFY

<p>Select Model Number</p> <p>HHALRECL . DW</p>	<p>Select Paint Color</p> <p>See page 395</p>
---	---

ACCELERATE®



Accelerate® 120° Degree Workstations shown with Contain® and Voi®.

ACCELERATE®

You know how quickly business can change. You have to be nimble. Adaptable. And you need an office space that can keep pace. That's Accelerate — a complete office system that maximizes style and comfort while minimizing startup time and costs. Trim, clean and modern, Accelerate's streamlined product line makes planning simple and ordering a breeze. So you can move at the speed your business needs.



FEATURES

- Customize your spaces! Add fabric stackers for height and privacy, or glass stackers to let the light in.
- Accelerate's crisp details have been designed to meet today's contemporary aesthetic. Clean. Minimal. Beautiful.
- Accelerate panels are compatible with other HON products, like Abode desks, Contain storage and more.
- The interchangeable components allow you to customize your space with a clean, contemporary look — and change your mind without changing your furniture.

ACCELERATE® ORDERING INFORMATION

WORKSURFACES, COUNTERTOPS, CORNER SHELVES W/EDGE BAND

L1 LAMINATES CODES

Woodgrain

◆ Bourbon Cherry H
◆ Cognac COGN
◆ Florence Walnut LFW1
◆ Harvest C
◆ Kingswood Walnut LK11
◆ Mahogany N
◆ Mocha MOCH
◆ Natural Maple D
◆ Pinnacle PINC
◆ Shaker Cherry F
◆ Sterling Ash LSA1

Solid

◆ Black P
◆ Charcoal S
◆ Designer White LDW1
◆ Loft LOFT

Patterned

◆ Sheer Mesh A5
◆ Silver Mesh B9
◆ Steel Mesh A9
◆ Canyon Zephyr K9
◆ Desert Zephyr K8
◆ Shadow Zephyr K1
◆ Gray G2
◆ Grey Tigris L6
◆ White G1
◆ Whitestone K4

L2 LAMINATES CODES

Woodgrain

◆ Lowell Ash LLA1
◆ Natural Recon LNR1
◆ Phantom Ecru LPE1
◆ Portico Teak LPT1
◆ Skyline Walnut LSW1

(Door panels not available in L2)

WORKSURFACE EDGE BAND

◆ Black P
◆ Bourbon Cherry H
◆ Charcoal S
◆ Cognac COGN
◆ Designer White DW
◆ Florence Walnut FW
◆ Greige R
◆ Harvest C
◆ Kingswood Walnut KI
◆ Light Gray Q
◆ Loft LOFT
◆ Lowell Ash DL
◆ Mahogany N
◆ Mocha MOCH
◆ Muslin T
◆ Natural Maple D
◆ Natural Recon NR
◆ Phantom Ecru PE
◆ Pinnacle PINC
◆ Platinum K
◆ Portico Teak DP
◆ Shadow SHDW
◆ Shaker Cherry F
◆ Skyline Walnut SW
◆ Sterling Ash SA

WORKSURFACE GROMMET

◆ Black P
◆ Brownstone EY
◆ Charcoal S
◆ Fossil EH
◆ Greige T5
◆ Light Gray Q
◆ Loft LOFT
◆ Muslin T3
◆ Shadow SHDW
◆ Titanium T1
◆ Designer White DW
◆ Champagne Metallic T4
◆ Platinum Metallic T1

FRAMES, TRIM, METAL TILES, CUSTOM BRACKET KIT, WORKSURFACE SUPPORTS, STEEL OVERHEAD STORAGE CHASSIS

PAINT CODES

◆ Black P
◆ Brownstone P7D
◆ Charcoal S
◆ Designer White PJW
◆ Fossil P28
◆ Greige T5
◆ Light Gray Q
◆ Loft LOFT
◆ Muslin T3
◆ Putty L
◆ Shadow SHDW
◆ Titanium P8T

◆ Champagne Metallic T4
◆ Platinum Metallic T1
◆ Silver PR6
◆ Solar Black P8X

DUPLEX/PORTED TILE

◆ Black P
◆ Brownstone P7D
◆ Charcoal S
◆ Designer White DW
◆ Loft LOFT
◆ Muslin T3
◆ Titanium T1

Recommendations

Paint	Duplex-Data Code
Black P Black P
Brownstone P7D Brownstone EY
Charcoal S Charcoal S
Designer White PJW Designer White DW
Fossil P28 Charcoal S
Greige T5 Muslin T3
Light Gray Q Loft LOFT
Loft LOFT Loft LOFT
Muslin T3 Muslin T3
Putty L Black P
Shadow SHDW Muslin T3
Silver PR6 Titanium T1
Titanium P8T Titanium T1
Champagne Metallic T4 Muslin T3
Platinum Metallic T1 Titanium T1

► LAMINATE TOPS

SPECIFY: Model Number.
Laminate.
Edge Color.
Grommet Color

EXAMPLE: HWR2424P.K8.R.T5

► PANELS

SPECIFY: Model Number.
Fabric
Paint

EXAMPLE: HETP3520FP.APN11.S

► CONNECTORS

SPECIFY: Model Number.
Paint

EXAMPLE: HEC35PS.T3

◆◆◆ For lead time information see page 19.

* De-emphasized

Replacement Duplex Receptacle Covers are made from a polymer material and are available in the following colors only:

Black	P
Muslin	T3
Shadow	SHDW

ACCELERATE® FABRIC PATTERNS & CODES

PRICE CODE AA

FACTOR	FACT
◆ Bark	FACT20
◆ Barley	FACT15
◆ Cascade	FACT25
◆ Feather	FACT30

PRICE CODE A

APPOINT	APN
◆ Artichoke	APN11
◆ Blackberry	APN32
◆ Bronze	APN22
◆ Carbon	APN28
◆ Chai	APN12
◆ Cherry	APN30
◆ Dark Pewter	APN17
◆ Dune	APN15
◆ Espresso	APN23
◆ Framboise	APN31
◆ Frost	APN34
◆ Jet	APN27
◆ Lawn	APN25
◆ Mandarin	APN29
◆ Morel	APN09
◆ Nimbus	APN16
◆ Platinum	APN24
◆ Turquoise	APN26

CENTURION CU

◆ Apricot	CU47
◆ Bark	CU25
◆ Black	CU10
◆ Espresso	CU49
◆ Fog	CU03
◆ Frost	CU22
◆ Goldenrod	CU27
◆ Indigo	CU06
◆ Iris	CU50
◆ Iron Ore	CU19
◆ Jade	CU83
◆ Marsala	CU63
◆ Morel	CU24
◆ Navy	CU98
◆ Peacock	CU97
◆ Pear	CU84
◆ Ruby	CU67
◆ Sapphire	CU09

PRICE CODE A *continued*

ETCH*	ECH
◆ Axis	ECH13
◆ Blend	ECH14
◆ Cast	ECH12
◆ Highlight	ECH10
◆ Midtone	ECH11
◆ Outline	ECH08
◆ Shade	ECH09
◆ Tonal	ECH16
◆ Vanish	ECH15

EXCHANGE* EXG

◆ Iron	EXG916
◆ Nickel	EXG914
◆ Pistachio	EXG910
◆ Root	EXG913
◆ Rupee	EXG903
◆ Shadow	EXG911
◆ Silver	EXG915
◆ Sisal	EXG917
◆ Stone	EXG912

LANDSCAPE* LN

◆ Azure	LN55
◆ Cornsilk	LN15
◆ Drift	LN05
◆ Khaki	LN20
◆ Sheen	LN10
◆ Slate	LN35
◆ Umber	LN25
◆ Urban	LN30

LUCY* LC

◆ Aspen	LC32
◆ Cornsilk	LC30
◆ Dusk	LC22
◆ Fawn	LC33
◆ Graphite	LC34
◆ Mist	LC20
◆ Neutra	LC24
◆ Pewter	LC35
◆ Snowdrop	LC28

PRICE CODE A *continued*

REFLECTIONS*	REF
◆ Galvanized	REF29
◆ Ice	REF20
◆ Loggia	REF21
◆ Mistral	REF28
◆ Moonstone	REF23
◆ Pewter	REF22
◆ Stainless	REF24
◆ Vanilla	REF25
◆ Winter	REF27

REFUGE* RFG

◆ Artesian	RFG96
◆ Dune	RFG92
◆ Eclipse	RFG90
◆ Frost	RFG93
◆ Glacier	RFG91
◆ Mineral	RFG98
◆ Tidal	RFG94

SARTO* SRT

◆ Ash	SRT88
◆ Fog	SRT14
◆ Lemongrass	SRT49
◆ Mist	SRT45
◆ Mushroom	SRT76
◆ Oyster	SRT18
◆ Reef	SRT64
◆ Sesame	SRT93
◆ Shale	SRT52

TEMPEST* TP

◆ Dragonfly	TP30
◆ Frost	TP15
◆ Full Stream	TP80
◆ Gold Rush	TP10
◆ Slate	TP45
◆ Tumbleweed	TP70
◆ Wind Chill	TP40
◆ Zebra	TP35

NOTES: Centurion fabric not available on panels that exceed a width and height of 54".

Analog, Disperse, and Exchange panel fabrics will be applied pattern cut. Disperse will not be available on 72"W panels.

◆◆◆ For lead time information see page 19.

* Directional fabrics

ACCELERATE® FABRIC PATTERNS & CODES

PRICE CODE B		PRICE CODE B <i>continued</i>		PRICE CODE B <i>continued</i>		PRICE CODE B <i>continued</i>	
DISPERSE*	DISP	MICA*	MCA	SPIN*	SPIN	TERRAIN*	TRRN
◆ Autumn	DISP03	◆ Anthracite	MCA11	◆ Alabaster	SPIN02	◆ Bay	TRRN05
◆ Branch	DISP10	◆ Breeze	MCA18	◆ Cavern	SPIN03	◆ Bayou	TRRN35
◆ Coffee Bean	DISP13	◆ Bronze	MCA13	◆ Cobblestone	SPIN04	◆ Canyon	TRRN30
◆ Dusk	DISP09	◆ Buff	MCA14	◆ Ember	SPIN06	◆ Cliff	TRRN45
◆ Emerald City	DISP08	◆ Cremini	MCA17	◆ Flame	SPIN07	◆ Crest	TRRN25
◆ Gold Rush	DISP02	◆ Crystal	MCAWIT	◆ Heron	SPIN13	◆ Delta	TRRN10
◆ Igloo	DISP11	◆ Dew	MCA20	◆ Oat	SPIN01	◆ Plateau	TRRN15
◆ Ink	DISP06	◆ Dove	MCA12	◆ Ocean	SPIN12	◆ Ridge	TRRN20
◆ Mist	DISP12	◆ Fresh	MCA16	◆ Plum	SPIN15	◆ Valley	TRRN40
◆ Oatmeal	DISP15	◆ Mineral	MCA15	◆ Pool	SPIN11		
◆ Prince	DISP07	◆ Nectar	MCA19	◆ Raven	SPIN10		
◆ Reservoir	DISP01	◆ Shale	MCA10	◆ Rhubarb	SPIN14		
◆ Rose	DISP04			◆ Tropic	SPIN08		
◆ Spring	DISP05			◆ Willow	SPIN05		
◆ Steel	DISP16						
◆ Taupe	DISP14						

NOTES: Disperse and Exchange panel fabrics will be applied pattern cut. Disperse will not be available on 72"W panels.

◆◆◆ For lead time information see page 19.

* Directional fabrics

ACCELERATE® Typicals



Icon Legend on page 19

WORKSTATIONS

QTY	DESCRIPTION	MODEL	FABRIC GRADE	LIST PRICE	PRICE EXTENSION
2	Accelerate® Top Cap 72"W	HETC72		\$103	\$206
2	Tackable Panel 50"H x 72"W	HETP5072FP		\$583	\$1,166
1	"L" Connector 50"H	HEC50PLN		\$130	\$130
2	Panel Finished End Covers 50"H	HEFEC50P		\$58	\$116
2	Electrical Power Harness Panels w/Duplex Capacity	HH871272		\$216	\$432
1	Duplex Receptacle Circuit 1 3-1 & 2-2	HH871501		\$42	\$42
1	Duplex Receptacle Circuit 4 3-1 & 2-2	HH871504		\$42	\$42
1	Base In-Feed Cable Base 3-1 & 2-2	HH879072		\$229	\$229
1	Rectangular Worksurface 24"D x 48"W	HWR2448P		\$404	\$404
1	Rectangular Worksurface 24"D x 72"W	HWR2472P		\$529	\$529
1	24"D Cantilever - One Pair	HCTL242		\$83	\$83
1	Flat Bracket 24"D	HHN831124		\$64	\$64
1	External Stiffener 48"W	HLSL255C60		\$98	\$98
1	Flagship® Series Freestanding Pedestal "A" Pull B/B 15"W x 22 7/8"D x 28"H	H19723A		\$739	\$739
1	Flagship® Series Freestanding Pedestal "A" Pull F/F 15"W x 22 7/8"D x 28"H	H19823A		\$732	\$732
1	Pedestal-to-Panel Bracket, Left	HPD2PNBRK2L		\$110	\$110
1	Pedestal-to-Panel Bracket, Right	HPD2PNBRK2R		\$110	\$110
1	Lota® Mid-Back Chair	H2281	1	\$772	\$772

TOTAL: **\$6,004**

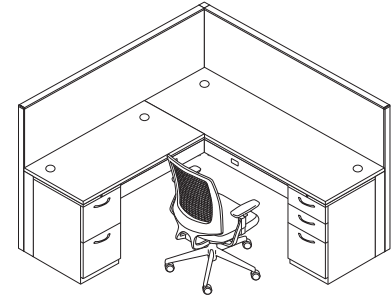

QTY	DESCRIPTION	MODEL	FABRIC GRADE	LIST PRICE	PRICE EXTENSION
2	Tackable Top-Tier Glass Panel 50"H x 20"W	HETP5020DP		\$509	\$1,018
2	Tackable Top-Tier Glass Panel 50"H x 42"W	HETP5042DP		\$604	\$1,208
5	Tackable Panel 65"H x 24"W	HETP6524FP		\$358	\$1,790
2	Tackable Panel 65"H x 48"W	HETP6548FP		\$459	\$918
2	Accelerate® Top Cap 72"W	HETC72		\$103	\$206
3	Accelerate® Top Cap 24"W	HETC24		\$38	\$114
2	Accelerate® Top Cap 20"W	HETC20		\$38	\$76
2	Accelerate® Top Cap 42"W	HETC42		\$61	\$122
4	Worksurface Bracket Kits	HWSB2		\$47	\$188
2	Flat Bracket 24"D	HHN831124		\$64	\$128
2	Straight Connector Kits	HCKTTPS		\$19	\$38
2	"L" Connector 50"H	HEC50PLN		\$130	\$260
2	"L" Connector 65"H	HEC65PLN		\$145	\$290
1	"T" Connector 65"H	HEC65PTN		\$140	\$140
2	Panel Finished End Covers 50"H	HEFEC50P		\$58	\$116
1	Panel Finished End Covers 65"H	HEFEC65P		\$65	\$65
2	In-line Variable Height Finishing Kit 15"W	HEVHF15P		\$57	\$114
2	Electrical Power Harness 3-1 & 2-2 48"W	HH871248		\$216	\$432
1	Electrical Pass-Thru w/o Power Block 3-1 & 2-2 48"W	HH871048		\$124	\$124
1	Base In-Feed Cable Base 3-1 & 2-2	HH879072		\$229	\$229
1	Duplex Receptacle Circuit 1 3-1 & 2-2	HH871501		\$42	\$42
1	Duplex Receptacle Circuit 2 3-1 & 2-2	HH871502		\$42	\$42
1	Duplex Receptacle Circuit 4 3-1 & 2-2	HH871504		\$42	\$42
1	Duplex Receptacle Circuit 1 3-1 & 2-2	HH871506		\$42	\$42
2	Rectangular Worksurface 18"D x 42"W	HWR1842P		\$332	\$664
2	Rectangular Worksurface 24"D x 48"W	HWR2448P		\$404	\$808
2	Worksurface to Tower Bracket Kits	HSTB2W1		\$79	\$158
2	Stack-on Storage w/Sliding Doors 14 1/4"D x 48"W x 13"H	HLSL1448S		\$1,100	\$2,200
2	Voi® for Systems Stack-on Storage Panel Mounted Bracket	HLSLPMB		\$131	\$262
2	Voi® Mobile Pedestal 15 3/4"W x 21 1/16"D x 21 1/16"H	HLSL2016MP2	1	\$813	\$1,626
2	Voi® Pedestal Cushion	HLSL2016PH2	2	\$339	\$678
1	Voi® Personal Storage Tower (LH) 24"D x 24"W x 65"H	HLSLW446LP		\$2,660	\$2,660
1	Voi® Personal Storage Tower (RH) 24"D x 24"W x 65"H	HLSLW446RP		\$2,660	\$2,660
2	Nucleus® 4-Way Stretch Back Work Chair	HN1	1	\$865	\$1,730

TOTAL: **\$21,190**

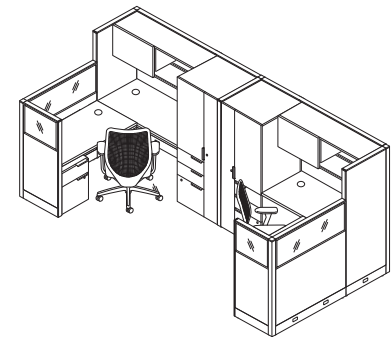



Icon Legend on page 19

ACCELERATE® Typicals

WORKSTATIONS

QTY	DESCRIPTION	MODEL	FABRIC GRADE	LIST PRICE	PRICE EXTENSION
1	In-Line Connector	HCKTTPS		\$19	\$19
2	Tackable Panel 42½"H x 24"W	HETP4224FP		\$295	\$590
2	Tackable Panel 42½"H x 60"W	HETP4260FP		\$415	\$830
2	Accelerate® Top Cap 60"W	HETC60		\$84	\$168
2	Accelerate® Top Cap 24"W	HETC24		\$38	\$76
4	Accelerate® Countertop Kit	HECB42		\$53	\$212
2	Worksurface Bracket Kit	HWSB2		\$47	\$94
1	Universal Support Leg 24"D	HRVCLG24		\$197	\$197
2	"L" Connector 42½"H	HEC42PLN		\$112	\$224
2	Panel Finished End Covers 42½"H	HEFEC42P		\$54	\$108
1	Base In-Feed Cable Base 3-1 & 2-2	HH879072		\$229	\$229
1	Electrical Pass-Thru Cable w/Duplex For 24"W Panel	HH871124		\$129	\$129
2	Electrical Power Harness 3-1 & 2-2 60"W	HH871260		\$216	\$432
2	Duplex Receptacle Circuit 4 3-1 & 2-2	HH871504		\$42	\$84
2	Rectangular Worksurface 24"D x 60"W	HWR2460P		\$477	\$954
2	Straight Countertop 60"W x 15"D	HBCSR1560P		\$378	\$756
2	Flagship® Mobile Series Pedestal "A" Pull B/B/F 15"W x 22½"D x 28"H	H18723A		\$751	\$1,502
2	Ignition® Mid-Back Work Chair	HIWM3	1	\$770	\$1,540
				TOTAL:	\$8,144



QTY	DESCRIPTION	MODEL	FABRIC GRADE	LIST PRICE	PRICE EXTENSION
3	Systems Corner Worksurface w/ 120° Curve Edge 42"W x 24"D	HBWCT4224P		\$833	\$2,499
3	Systems 60° Wedge Worksurface Edgeband 24"W x 24"D	HCWQT2424P		\$393	\$1,179
3	120° 2-way Connector 35"H	HEC35P2N		\$89	\$267
2	Panel Finished End Covers 35"H	HEFEC35P		\$51	\$102
4	Frameless Glass 15"H x 42"W	HEFG1542		\$556	\$2,224
4	Tackable Panel 35"H x 42"W	HETP3542FP		\$317	\$1,268
4	Electrical Power Harness 3-1 & 2-2 Systems 42"W	HH871242		\$216	\$864
1	Duplex Receptacle Circuit 1 3-1 & 2-2 Systems	HH871501		\$42	\$42
2	Duplex Receptacle Circuit 2 3-1 & 2-2 Systems	HH871502		\$42	\$84
2	Duplex Receptacle Circuit 3 3-1 System Only	HH871503		\$42	\$84
3	Duplex Receptacle Circuit 4 3-1 & 2-2 Systems	HH871504		\$42	\$126
1	Base In-Feed Cable Base 3-1 & 2-2 Systems	HH879072		\$229	\$229
3	Mobile Pedestal 20"W x 15½"D x 21½"H	HLSL2016MP2		\$813	\$2,439
3	Pedestal Cushion 20"W x 15½"D x 1"H	HLSL2016PH2	2	\$339	\$1,017
2	Abound® Left End Panel 29"H x 24"D	HRVEP2429L		\$223	\$446
2	Abound® Right End Panel 29"H x 24"D	HRVEP2429R		\$223	\$446
2	Systems Rectangular Worksurface Edgeband 24"D x 42"W	HWR2442P		\$380	\$760
6	Universal Support Leg 24"D	HRVCLG24		\$197	\$1,182
				TOTAL:	\$15,258

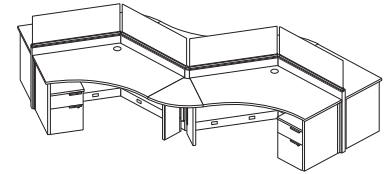

ACCELERATE® PANELS OVERVIEW

INTERSECTING CONNECTIONS

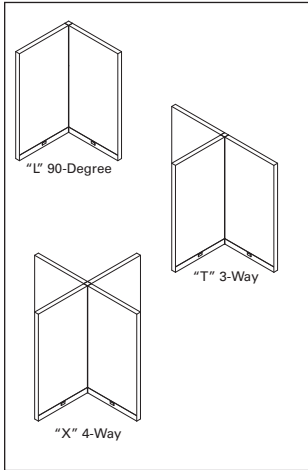

“L”, “T” and “X” connector kits are used when connecting frames at intersecting runs. For “L”, “T” and “X” connector kits, add 2¼” to the total length of the panel run for each intersection, whether located in the middle or at the end of the run.

Wall starter kits provide a means to affix a panel run to a permanent building wall. Kit adds ⅞” to length of panel run.

STACKING PANELS

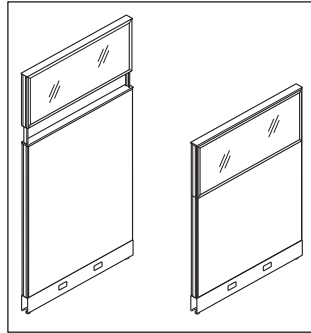

Stackers add 15” to the height of the base panel and can be ordered separately or as part of the panel model, see pages 465 and 468.

When adding stackers to an existing panel, a new connector must be ordered, to the tallest panel height.

Please note that Stacking Panels are not to be used freestanding and must match the panel width of the panel it is stacking on.

Cannot use a stacking panel on a Top Tier Glass Panel model.

Stackers ship with pins to connect stacker to post connector for added rigidity.

Stackers can be stacked up to 80”H on a base panel. Overheads can be placed on the first stacker only, up to 65”H. Voi overheads are not to be placed on stackers.

Top View		
Panel	S	Panel
→	← 2¼"	
Panel	S	Panel

Extended straight connector kit “S” can be used to keep continuous runs dimensionally consistent with opposing panel runs which incorporate “T” or “X” intersections. (Add 2¼” to the length of the run for every extended straight connector used.)

IN-LINE CONNECTIONS

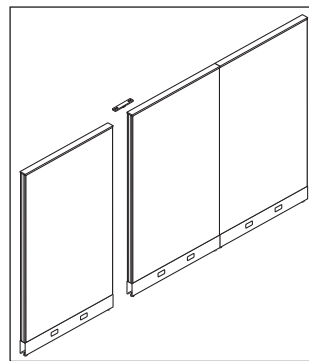

There is no incremental increase in dimension along the panel run when using an in-line connector kit.

END OF RUN

Finished end trim must be specified for the unconnected sides of panel. When adding a stacking panel, order finished end trim in the height that matches the total stacked height. Move the end cap from the standard frame end trim to the stacking frame end trim.

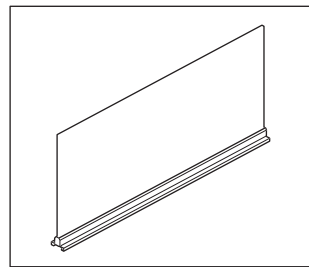

Accelerate® frameless glass is single pane, ⅜” thick laminate safety glass, available in clear or frosted glass.

Frameless glass can only be used on the tallest panel in a typical, not at in-line or post connectors with variable height. Frameless glass is not allowed on top of glass stackers or glass header panels and hanging or stacking on frameless glass is not permitted.

Frameless glass can span multiple panels with one piece of glass, creating a clean, seamless look.

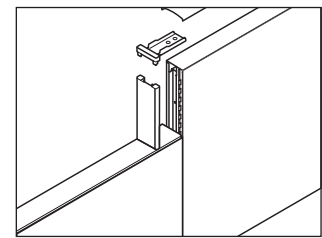

IN-LINE VARIABLE HEIGHT TRIM
In-line connections between different height panels require trim to cover the exposed frame of the taller panel.

VARIABLE HEIGHT CONNECTOR TRIM

L, X and T connections between different height panels require trim to cover the exposed connector. The bottom of the trim is flat to match the profile of the top cap. Models are designated as “Variable Height Connector Trim”. For variable height connections in a Y configuration, contact the Accelerate Specials Department.

Multiple-height connections are accomplished by combining standard height panel connectors (35”H, 42”H, 50”H and 65”H) with shorter trim kits (7”H, 15”H, 22”H and 30”H). Start from the top-down — select the standard connector that corresponds to the height and connection type of the tallest panel. (See examples.)

ACCELERATE® PANELS OVERVIEW

Example 1

Connectors required:
1-50"H "T" Connector
2-15"H Connector VH Kit
2-35"H End Trim
1-65"H End Trim

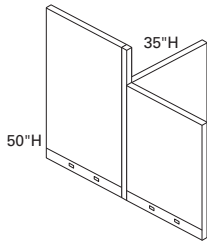

In variable height "T" connections — as shown above — you would use the connectors as indicated.

Example 2

Connectors required:
1-50"H "X" Connector
2-7½"H Connector VH Kit
2-50"H End Trim
2-42"H End Trim

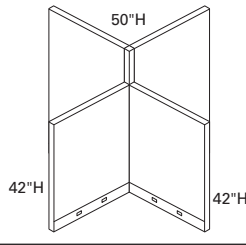

Example 3

Connectors required:
1-65"H "T" Connector
1-15"H Connector VH Kit
1-22½"H Connector VH Kit
1-65"H End Trim
1-50"H End Trim
1-42"H End Trim

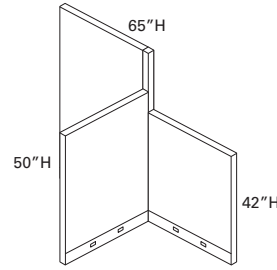

Example above represents Accelerate variable height "L" for 65" to 50".

TOP CAPS

Top caps must be specified as a separate model from the panel. Top caps can span more than one panel when panels are connected in an in-line.

ACCELERATE® WORKING WITH PANELS

PANELS

- Accelerate® Panels are 2½” thick and available in 4 heights / 8 widths.

NOTE: Actual panel height varies depending on position of levelers.

NOMINAL PANEL HEIGHT	PANEL WIDTHS							
	20"	24"	30"	36"	42"	48"	60"	72"
35"	20"	24"	30"	36"	42"	48"	60"	72"
42½"	20"	24"	30"	36"	42"	48"	60"	72"
50"	20"	24"	30"	36"	42"	48"	60"	72"
65"	20"	24"	30"	36"	42"	48"	60"	72"

Maximum Receptacle Capacity in Panel Base Pathways

Widths	20	24	30	36	42	48	60	72
Maximum of 1 duplex per panel side	N/A	X						
Maximum of 2 duplexes per panel side	N/A		X	X	X	X	X	X

The center of the duplex is always 12” from the end of the panel on all Accelerate® panels.

PANEL SPECIFICATION AND INSTALLATION NOTES

Definitions:

Parent Panel Run – Panels (or a single panel) configured in a straight line intended to divide space. It is usually longer than the panels used to stabilize it.

Return Panels – Panels attached to a parent run for the purpose of stabilizing it. Return panels may also have the effect of dividing space.

Note: Return panels must be no more than 30” lower than the maximum height of the parent panel run. When stacking, the maximum height allowed is 80”. This includes frameless glass. If attaching overhead storage, return panels must be the same height as parent run.

Method 1: Opposing Returns

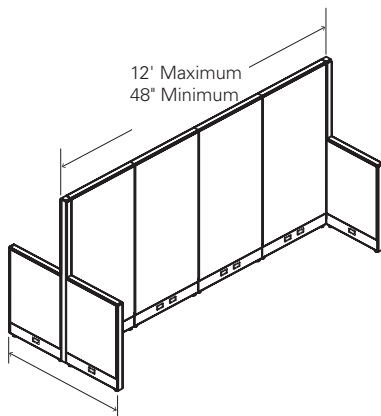

Method 2: Single-Sided

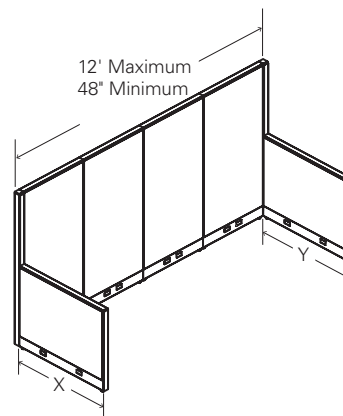

A parent panel run must be a minimum of 4 feet and a maximum of 12 feet, and must have a minimum of two return panels extended in opposing directions on each side of the parent run.

Panel Run Length	Minimum Return Panels	Minimum Return Panels with Stack-ons
48"	20"	20"
54"	20"	20"
60"	20"	20"
66"	20"	20"
72"	20"	20"
78"	20"	20"
84"	20"	20"
90"	20"	20"
96"	20"	20"
102"	20"	20"
108"	24"	24"
114"	24"	24"
120"	24"	24"
144"	24"	24"

A parent panel run must be a minimum of 4 feet and a maximum of 12 feet, and must have a minimum of two return panels (X+Y) extended in one direction (one at the beginning and at the end of the parent run) as defined below.

Panel Run Length	Minimum Return Panels Total (X+Y)	Minimum Return Panels Total (X+Y) with Stack-ons
48"	84"	84"
54"	84"	84"
60"	84"	84"
66"	84"	84"
72"	84"	84"
78"	84"	84"
84"	84"	84"
90"	84"	84"
96"	84"	84"
102"	84"	84"
108"	84"	96"
114"	84"	96"
120"	84"	96"
144"	84"	96"

Design:

- Slots allow hanging worksurfaces and hang-on units, in 1” increments.
- Panels standard with two adjustable leveling glides.
- No panel creep.
- Meets or exceeds ANSI/BIFMA Standards.

Top Tier and Stacking Panels

- Available in tackable fabric as well as clear and frosted glass.
- Select from a full height panel/top tier panels or stackers.
- Stackers can be stacked up to 80”H on a base panel.
- Overheads can be placed on the first stacker only, up to 65”H. Voi overheads are not to be placed on stackers.

ACCELERATE® CONNECTOR OVERVIEW

CONNECTOR KITS — ACCELERATE®

- TPS** In-line Connector
- PSN** Extended Straight Connector
- PLN** “L” Connector
- PTN** “T” Connector
- PXN** “X” Connector
- P2N** 120° 2-way Connector
- P3N** 120° 3-way Connector
- CV** Connector Variable Height Finishing Kit
- VH** In-line Variable Height Finishing Kit

ADDITIONAL MODELS FOR USE WITH CONNECTOR KITS

- FE** Finished End Covers
- WS** Wall Starter Kit
- WT** Wall Track

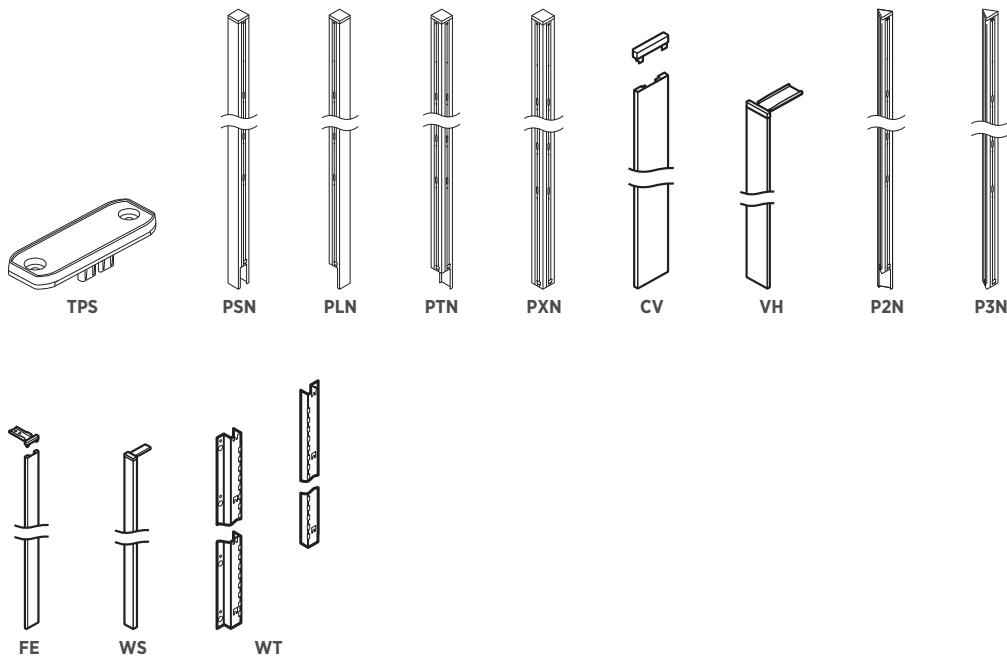

Panel-to-Panel Connector

- Attaches same height, panel-to-panel in a straight run with screws.
- Ensures alignment on panels in a straight run.

Wall Starter Kit (see page 473)

- Anchor devices are not supplied with the wall starter kit. Refer to Accelerate® Installation Instructions for appropriate hardware.
- Adds 7/8" to length of run.

ACCELERATE® Tackable Raceway Panels

GSA SIN 33721



Icon Legend on page 19

WORKSTATIONS

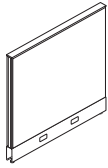

DESCRIPTION

MODEL

SHIP WEIGHT

CUBE

CORE LIST PRICE BY CODE

AA

A

B

35" H Tackable Acoustical Panels

35" H x 20" W	HETP3520FP	13	1.0	\$268	\$279	\$298
35" H x 24" W	HETP3524FP	14	1.2	\$279	\$290	\$332
35" H x 30" W	HETP3530FP	16	1.5	\$291	\$304	\$349
35" H x 36" W	HETP3536FP	18	1.8	\$313	\$327	\$374
35" H x 42" W	HETP3542FP	20	2.1	\$317	\$332	\$385
35" H x 48" W	HETP3548FP	23	2.4	\$334	\$350	\$405
35" H x 60" W	HETP3560FP	27	3.0	\$363	\$381	\$446
35" H x 72" W*	HETP3572FP	33	3.6	\$508	\$527	\$600

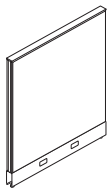

42 1/2" H Tackable Acoustical Panels

42 1/2" H x 20" W	HETP4220FP	14	1.2	\$283	\$296	\$328
42 1/2" H x 24" W	HETP4224FP	16	1.5	\$295	\$308	\$340
42 1/2" H x 30" W	HETP4230FP	18	1.8	\$313	\$325	\$364
42 1/2" H x 36" W	HETP4236FP	20	2.2	\$329	\$343	\$385
42 1/2" H x 42" W	HETP4242FP	23	2.6	\$358	\$374	\$423
42 1/2" H x 48" W	HETP4248FP	25	3.0	\$371	\$389	\$448
42 1/2" H x 60" W	HETP4260FP	30	3.7	\$415	\$434	\$503
42 1/2" H x 72" W*	HETP4272FP	36	4.4	\$534	\$556	\$635

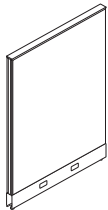

50" H Tackable Acoustical Panels

50" H x 20" W	HETP5020FP	16	1.4	\$324	\$339	\$402
50" H x 24" W	HETP5024FP	17	1.7	\$337	\$352	\$415
50" H x 30" W	HETP5030FP	20	2.2	\$346	\$362	\$406
50" H x 36" W	HETP5036FP	22	2.6	\$357	\$373	\$423
50" H x 42" W	HETP5042FP	25	3.0	\$400	\$418	\$476
50" H x 48" W	HETP5048FP	28	3.5	\$423	\$443	\$508
50" H x 60" W	HETP5060FP	32	4.3	\$462	\$483	\$557
50" H x 72" W*	HETP5072FP	38	5.2	\$583	\$606	\$692

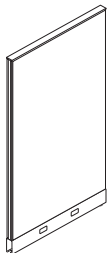

65" H Tackable Acoustical Panels

65" H x 20" W	HETP6520FP	19	1.9	\$345	\$360	\$408
65" H x 24" W	HETP6524FP	20	2.3	\$358	\$373	\$421
65" H x 30" W	HETP6530FP	23	2.8	\$377	\$393	\$444
65" H x 36" W	HETP6536FP	26	3.4	\$404	\$422	\$480
65" H x 42" W	HETP6542FP	29	3.9	\$440	\$459	\$524
65" H x 48" W	HETP6548FP	32	4.5	\$459	\$479	\$552
65" H x 60" W	HETP6560FP	37	5.6	\$490	\$510	\$592
65" H x 72" W*	HETP6572FP	43	6.8	\$663	\$686	\$778

NOTES:

- Panels are 2 1/8" thick.
- Baserails ship standard with panels.
- Top caps ordered separately; see page 467.
- Packaging: stretch wrapped with edge protection.
- Base rail matches trim color.
- For worksurfaces that can be used with Abound® and Accelerate® systems, see pages 581-591.
- Panel end trim ordered separately; see page 473.
- Panels may be connected end to end, with wall starter kit, or with panel connectors; see pages 471-473.
- Order Accelerate® connectors separately; see page 471.
- Panels have a class A fire rating.
- Bulk packing is available in quantities of 3 or 9.
- Fabrics and finishes available on pages 455, 456-457.

- ! Raceway panels option only.
- ! Do not remove electrical knockouts unless duplex is needed. For replacement covers, see page 574.
- ! Accepts electrical power kits, except for 20" W. See page 572 for electrical.
- ! Stack on panels add 15" of height and can be added to any monolithic panel. See stackers on pages 468-469.
- ! Disperse and Analog fabrics are not available on 72" W panels.
- ! If adding to existing panels produced prior to 04/13/16, please contact Customer Support for compatibility.
- ! If a third cutout for data is desired, order the separate kickplate model HEBPLATE.
- ! Panels should not be used in unsupported applications or take the place of permanent walls. Panels are intended to be supported with floor supports and/or storage or tied in with worksurfaces. Refer to Specifying and Design Guide pages.

HOW TO SPECIFY

Select Model Number

HETP3520FP

Select Fabric

See pages 456-457

APN15

Select Trim Color

See page 455

P1 Paint (no upcharge)
P2 Paint (\$30 upcharge)

S



Icon Legend on page 19

ACCELERATE® Top-Tier Glass Panels

WORKSTATIONS

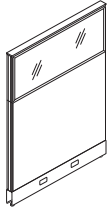

DESCRIPTION

50" H Tackable Panels — Top-Tier Glass

- 50" H x 20" W
- 50" H x 24" W
- 50" H x 30" W
- 50" H x 36" W
- 50" H x 42" W
- 50" H x 48" W
- 50" H x 60" W
- 50" H x 72" W*

MODEL	SHIP WEIGHT	CUBE	CORE LIST PRICE BY CODE		
			AA	A	B
HETP5020DP	21 Ⓢ	1.4	\$509	\$529	\$592
HETP5024DP	23 Ⓢ	1.7	\$530	\$550	\$613
HETP5030DP	27 Ⓢ	2.2	\$541	\$563	\$607
HETP5036DP	31 Ⓢ	2.6	\$552	\$574	\$624
HETP5042DP	34 Ⓢ	3.0	\$604	\$628	\$686
HETP5048DP	39 Ⓢ	3.5	\$630	\$657	\$722
HETP5060DP	46	4.3	\$679	\$709	\$784
HETP5072DP	55	5.2	\$905	\$938	\$1023

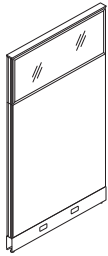

65" H Tackable Panels — Top-Tier Glass

- 65" H x 20" W
- 65" H x 24" W
- 65" H x 30" W
- 65" H x 36" W
- 65" H x 42" W
- 65" H x 48" W
- 65" H x 60" W
- 65" H x 72" W*

HETP6520DP	24 Ⓢ	1.9	\$533	\$554	\$602
HETP6524DP	27 Ⓢ	2.3	\$549	\$570	\$618
HETP6530DP	30 Ⓢ	2.8	\$568	\$590	\$641
HETP6536DP	34 Ⓢ	3.4	\$600	\$624	\$682
HETP6542DP	39 Ⓢ	3.9	\$643	\$669	\$734
HETP6548DP	43 Ⓢ	4.5	\$665	\$692	\$765
HETP6560DP	51	5.6	\$694	\$724	\$808
HETP6572DP	60	6.8	\$988	\$1021	\$1113

NOTES:

- On top-tier panel models, the glass tier is 15" H.
- Glass is clear or frosted, tempered safety glass.
- Panels are 2 1/8" thick.
- Panels have steel baserails.
- Packaging: stretch wrapped with edge protection.
- Base rail matches trim color.
- Top caps ordered separately; see page 467.
- For worksurfaces that can be used with Abound® and Accelerate® systems, see pages 581-591.
- Panel end trim ordered separately; see page 473.
- Panels may be connected end to end, with wall starter kit, or with panel connectors; see pages 471-473.
- Order Accelerate® connectors separately; see page 471.
- Panels have a class A fire rating.
- Bulk packing is available in quantities of 3 or 9.
- Fabrics and finishes available on pages 455, 456-457.
- ⓘ Raceway panels option only.
- ⓘ Do not remove electrical knockouts unless duplex is needed. For replacement covers, see page 574.
- ⓘ Accepts electrical power kits, except for 20" W. See page 572 for electrical.
- ⓘ Cannot stack stacker on top-tier glass panels.
- ⓘ Disperse and Analog fabrics are not available on 72" W panels.
- ⓘ If adding to existing panels produced prior to 04/13/16, please contact Customer Support for compatibility.
- ⓘ If a third cutout for data is desired, order the separate kickplate model HEBPLATE.
- ⓘ Panels should not be used in unsupported applications or take the place of permanent walls. Panels are intended to be supported with floor supports and/or storage or tied in with worksurfaces. Refer to Specifying and Design Guide pages.

HOW TO SPECIFY

<p>Select Model Number</p> <p style="font-family: monospace; font-size: 1.2em; letter-spacing: 0.5em;">H E T P 5 0 2 0 D P .</p>	<p>Select Fabric</p> <p>See pages 456-457</p> <p style="font-family: monospace; font-size: 1.2em; letter-spacing: 0.5em;">A P N 1 5 .</p>	<p>Select Trim Color</p> <p>See page 455</p> <p>P1 Paint (no upcharge) P2 Paint (\$30 upcharge)</p> <p style="font-family: monospace; font-size: 1.2em; letter-spacing: 0.5em;">S .</p>	<p>Select Glass</p> <p>Q Clear Glass R Frosted Glass (\$30 upcharge)</p> <p style="font-family: monospace; font-size: 1.2em; letter-spacing: 0.5em;">Q</p>
---	--	--	---

ACCELERATE® Panel Door

GSA SIN 33721



Icon Legend on page 19

WORKSTATIONS

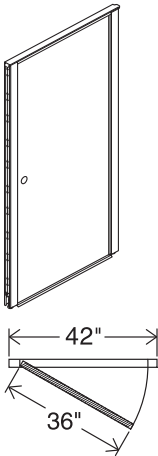

DESCRIPTION	MODEL	SHIP WEIGHT	CUBE	LIST PRICE BY PAINT GRADE	
				P1	P2
Door Panel — Laminate 42"W x 80"H NOTES: Ships with door, frame, hinges and hardware. Best placement of a door is at an L, T, X connector or wall starter connector for rigidity. Use of spanning top caps at an in-line will also help add additional rigidity. ⓘ Must be used with a base panel and stacker equaling 80"H.	HEPDMK42P	155.0	7.3	\$1928	\$1961

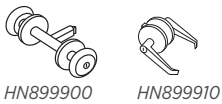

Standard Lock Set Door knob (polished brass) Door lever (brushed aluminum) NOTES: Door knob and lever are both keyed on one side.	HN899900	2.0 ⓘ	0.1	\$117	
	HN899910	2.0 ⓘ	0.1	\$324	



Abound® and Accelerate® Sliding Door 50"H x 42"W 65"H x 42"W 80"H x 42"W ⓘ Door is only available in Frosted Translucent Acrylic. Specify paint for frame. ⓘ Can only install Sliding Door at the end of a run, not at a corner. ⓘ A Mounting Bracket Kit must be ordered for each sliding door corresponding to the mounting panels width (30", 36", 42", or 48"W).	HH15042SD	28.0	5.5	\$2058	\$2094
	HH16542SD	38.0	7.1	\$2346	\$2382
	HH18042SD	46.0	8.6	\$2871	\$2907

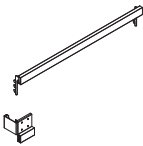

Accelerate® Mounting Kit for Sliding Door For 30"W Panel For 36"W Panel For 42"W Panel For 48"W Panel NOTES: Specify paint.	HESDMK30	4.0	0.4	\$171	\$183
	HESDMK36	5.0	0.5	\$180	\$192
	HESDMK42	6.0	0.5	\$187	\$199
	HESDMK48	7.0	0.5	\$196	\$208



Carpet Grippers NOTES: Used with Glide Towers Shipped 12 per package No need to specify paint	HICG12	0.5 ⓘ	0.1	\$20	
---	---------------	-------	-----	-------------	--



Coat Hooks Package of six NOTES: Compatible with Accelerate® and Abound® panels. ⓘ Black only.	HHPMC6	1.0 ⓘ	0.2	\$87	
--	---------------	-------	-----	-------------	--

NOTES:

- Order handle separately. See handle model options above.
- Specify top caps separately when ordering the laminate panel door; see page 467.
- Order Accelerate® connectors separately; see page 471.
- Fabrics and finishes available on pages 455, 456-457.
- The Sliding Doors are available in 50", 65", and 80"H models and can mount to 30", 36", 42", and 48"W panels.
- All doors are 42" wide, provide a 36"W opening, and are non-handed.

HOW TO SPECIFY

Select Model Number H E P D M K 4 2 P .	Select Trim Color See page 455 T 4 .	Select Door Laminate L2 Laminate Upcharge \$60 See page 455 H
---	---	---



Icon Legend on page 19

ACCELERATE® Top Caps

DESCRIPTION	MODEL	SHIP WEIGHT	CUBE	LIST PRICE BY PAINT GRADE	
				P1	P2
Panel Top Cap					
20"W	HETC20	1.5	0.3	\$38	\$58
24"W	HETC24	1.6	0.3	\$38	\$58
30"W	HETC30	1.8	0.3	\$46	\$66
36"W	HETC36	2.0	0.3	\$58	\$78
42"W	HETC42	2.2	0.3	\$61	\$81
48"W	HETC48	3.4	0.4	\$68	\$88
60"W	HETC60	3.9	0.6	\$84	\$104
66"W	HETC66	4.0	0.6	\$99	\$119
72"W	HETC72	5.3	0.8	\$103	\$123
78"W	HETC78	6.5	0.8	\$107	\$127
84"W	HETC84	6.7	0.9	\$117	\$137
90"W	HETC90	7.0	0.9	\$123	\$143
96"W	HETC96	7.2	0.9	\$129	\$149

NOTES:

- Models above are specified for panel models on pages 464-465.
 - Top caps ship separately from panels.
 - Top caps are able to span multiple panels for a clean aesthetic.
 - Top caps are bulk packed for ease at installation sites.
- ! If adding to existing panels produced prior to 04/13/16, please contact Customer Support for compatibility.

HOW TO SPECIFY

Select Model Number	Select Paint Color
See page 455	See page 455
H E T C 2 0 .	T 3

DESCRIPTION	MODEL	SHIP WEIGHT	CUBE	LIST PRICE BY PAINT GRADE	
				P1	P2
Accelerate® Base Pathway Cover w/Additional Knockout					
36"W	HEBPLATE336	7	0.4	\$74	\$84
42"W	HEBPLATE342	8	0.4	\$76	\$86
48"W	HEBPLATE348	9	0.4	\$79	\$89
60"W	HEBPLATE360	11	0.5	\$90	\$100
72"W	HEBPLATE372	14	0.6	\$100	\$110

NOTES: Specify paint, see page 455.
SPECIFYING EXAMPLE: HEBPLATE336.T4

NOTES:

- ! Specify Pathways to match trim color.
- ! Standard raceways with two knockouts are standard on panels. If additional three knockout kickplate is ordered, the two port version can be saved or discarded.

HOW TO SPECIFY

Select Model Number	Select Paint Color
See page 455	See page 455
H E B P L A T E 3 3 6 .	T 4

ACCELERATE® Stacking Panels

GSA SIN 33721



Icon Legend on page 19

WORKSTATIONS



DESCRIPTION	MODEL	SHIP WEIGHT	CUBE	CORE LIST PRICE BY CODE		
				AA	A	B
15”H Stacking Panels — Fabric						
15”H x 20”W	HES1520F	6	0.5	\$184	\$205	\$253
15”H x 24”W	HES1524F	7	0.6	\$203	\$224	\$272
15”H x 30”W	HES1530F	8	0.8	\$219	\$241	\$292
15”H x 36”W	HES1536F	9	0.9	\$235	\$259	\$317
15”H x 42”W	HES1542F	11	1.1	\$254	\$280	\$345
15”H x 48”W	HES1548F	12	1.2	\$270	\$297	\$370
15”H x 60”W	HES1560F	14	1.5	\$305	\$335	\$419
15”H x 72”W	HES1572F	17	1.8	\$579	\$612	\$704

NOTES:

- Stacking panels ship without top caps.
- Stackers add 15” or 30” to the height of the base panel.
- Stacker ships with pins to connect stacker to post connector for added rigidity.
- Select complete panels with top-tier glass, or add glass/fabric stackers separately to existing panels. See page 465 for complete panels information.
- Not to be used freestanding.
- Stackers can be stacked up to 80”H on a base panel or 30” of stacker height total, whichever comes first.
- The first stacker on a base panel is weight bearing and can accommodate overhead storage up to 65”H.
- Stacking model must match the width of the panel it is stacking on.
- Total panel height cannot exceed 80” high. Glass stacker must be the top tier. A stacking panel cannot be placed above a glass panel or glass stacker. Frameless Glass can be installed on a fabric stacker.
- Voi overheads not to be placed on stackers.
- If adding to existing panels produced prior to 04/13/16, please contact Customer Support for compatibility.

HOW TO SPECIFY

Select Model Number	Select Fabric Color
	See pages 456-457
H E S 1 5 2 0 F .	A P N 1 1

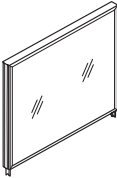
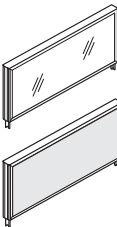

ACCELERATE[®] Stacking Panels

	DESCRIPTION	MODEL	SHIP WEIGHT	CUBE	CLEAR GLASS	FROSTED GLASS	
	30"H Stacking Panels — Glass						
	30"H x 20"W	HES3020G	14 Ⓔ	1.0	\$600	\$630	
	30"H x 24"W	HES3024G	17 Ⓔ	1.2	\$631	\$661	
	30"H x 30"W	HES3030G	20 Ⓔ	1.5	\$715	\$745	
	30"H x 36"W	HES3036G	23 Ⓔ	1.8	\$739	\$769	
	30"H x 42"W	HES3042G	26 Ⓔ	2.1	\$818	\$848	
	30"H x 48"W	HES3048G	29 Ⓔ	2.4	\$881	\$911	
	30"H x 60"W	HES3060G	36	3.0	\$1010	\$1040	
	NOTES: 30"H stacker ships with pins to connect stacker to post connector for added rigidity.						
	15"H Stacking Panels — Glass						
	15"H x 20"W	HES1520G	8 Ⓔ	0.5	\$400	\$430	
	15"H x 24"W	HES1524G Ⓢ	9 Ⓔ	0.6	\$423	\$453	
	15"H x 30"W	HES1530G Ⓢ	11 Ⓔ	0.8	\$477	\$507	
	15"H x 36"W	HES1536G Ⓢ	12 Ⓔ	0.9	\$495	\$525	
	15"H x 42"W	HES1542G	14 Ⓔ	1.1	\$546	\$576	
	15"H x 48"W	HES1548G Ⓢ	16 Ⓔ	1.2	\$588	\$618	
	15"H x 60"W	HES1560G Ⓢ	19 Ⓔ	1.5	\$673	\$703	
		15"H x 72"W	HES1572G	22	1.8	\$819	\$849

NOTES:

- Stacking panels ship without top caps.
- Stackers add 15" or 30" to the height of the base panel.
- Stacker ships with pins to connect stacker to post connector for added rigidity.
- Select complete panels with top-tier glass, or add glass/fabric stackers separately to existing panels. See page 465 for complete panels information.

- ⓘ Not to be used freestanding.
- ⓘ Stackers can be stacked up to 80"H on a base panel or 30" of stacker height total, whichever comes first.
- ⓘ The first stacker on a base panel is weight bearing and can accommodate overhead storage up to 65"H.
- ⓘ Stacking model must match the width of the panel it is stacking on.
- ⓘ Total panel height cannot exceed 80" high. Glass stacker must be the top tier. A stacking panel cannot be placed above a glass panel or glass stacker. Frameless Glass can be installed on a fabric stacker.
- ⓘ If adding to existing panels produced prior to 04/13/16, please contact Customer Support for compatibility.

HOW TO SPECIFY

Select Model Number <div style="border: 1px solid black; padding: 2px; display: flex; gap: 5px;"> HES3020G </div>	Select Paint Color See page 455 P1 Paint (no upcharge) P2 Paint (\$30 upcharge) <div style="border: 1px solid black; padding: 2px; display: flex; gap: 5px;"> T1 </div>	Select Glass Q Clear Glass R Frosted Glass <div style="border: 1px solid black; padding: 2px; display: flex; gap: 5px;"> Q </div>
---	--	--

ACCELERATE® Frameless Glass

GSA SIN 33721



Icon Legend on page 19

WORKSTATIONS

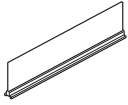

DESCRIPTION

7 1/2" H Frameless Glass

7 1/2" H x 20" W
7 1/2" H x 24" W
7 1/2" H x 30" W
7 1/2" H x 36" W
7 1/2" H x 42" W
7 1/2" H x 48" W
7 1/2" H x 54" W
7 1/2" H x 60" W
7 1/2" H x 66" W
7 1/2" H x 72" W

MODEL	SHIP WEIGHT	CUBE	CLEAR GLASS	FROSTED GLASS
HEFG0720	17	0.4	\$315	\$345
HEFG0724	18	0.5	\$371	\$408
HEFG0730	18	0.5	\$400	\$441
HEFG0736	21	0.6	\$460	\$507
HEFG0742	25	0.7	\$491	\$541
HEFG0748	28	0.8	\$528	\$582
HEFG0754	28	0.8	\$595	\$656
HEFG0760	35	1.0	\$646	\$712
HEFG0766	35	1.0	\$720	\$792
HEFG0772	42	1.9	\$764	\$842

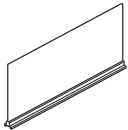

15" H Frameless Glass

15" H x 20" W
15" H x 24" W
15" H x 30" W
15" H x 36" W
15" H x 42" W
15" H x 48" W
15" H x 54" W
15" H x 60" W
15" H x 66" W
15" H x 72" W

HEFG1520	27	1.3	\$390	\$420
HEFG1524	28	1.5	\$422	\$459
HEFG1530	28	1.5	\$451	\$492
HEFG1536	34	1.8	\$518	\$565
HEFG1542	39	2.0	\$556	\$606
HEFG1548	45	2.3	\$600	\$654
HEFG1554	51	2.6	\$657	\$718
HEFG1560	57	2.8	\$732	\$798
HEFG1566	62	3.2	\$799	\$871
HEFG1572	67	3.5	\$863	\$941

NOTES:

- Glass is a single-pane, 3/8" laminated safety glass.
- Available in clear or frosted glass.
- Frameless Glass can span multiple panels with one piece of glass.
- Lamination is in the center of the glass, making both clear and frosted glass a writable surface with dry-erase markers.
- ⚠ Glass tiles have a Class A fire rating.
- ⚠ Frameless Glass can only be used on the tallest panel of the typical. Please see published Tailored Solutions models on honready.com for variable height applications.
- ⚠ Frameless Glass cannot be used on top of glass stackers or headers.
- ⚠ Frameless Glass can only be used on the top of panels. Glass integrates into top cap trim. Do not order a separate top cap model for your frame when using Frameless Glass.
- ⚠ Cannot hang or stack on top of Frameless Glass.
- ⚠ If adding to existing panels produced prior to 04/13/16, please contact Customer Support for compatibility.

HOW TO SPECIFY

Select Model Number

HEFG1520.

Select Paint Color

See page 455
P1 Paint (no upcharge)
P2 Paint (\$30 upcharge)

T1.

Select Glass Option

Q Clear Glass
R Frosted Glass

Q



Icon Legend on page 19

ACCELERATE® Strengthened Connection Posts

WORKSTATIONS

	DESCRIPTION	MODEL	SHIP		LIST PRICE BY PAINT GRADE		
			WEIGHT	CUBE	P1	P2	P3
	120° 2-Way Connector Posts						
	For 35"H Panels	HEC35P2N	6	0.5	\$89	\$98	\$115
	For 42½"H Panels	HEC42P2N	6	0.5	\$107	\$116	\$133
	For 50"H Panels	HEC50P2N	7	0.6	\$125	\$134	\$151
	For 57½"H Panels	HEC57P2N	8	0.8	\$133	\$142	\$159
	For 65"H Panels	HEC65P2N	8	0.8	\$140	\$149	\$166
	For 72½"H Panels	HEC72P2N	9	0.9	\$148	\$157	\$174
	For 80"H Panels	HEC80P2N	9	0.9	\$155	\$164	\$181
	120° 3-Way Connector Posts						
	For 35"H Panels	HEC35P3N	6	0.5	\$84	\$93	\$110
	For 42½"H Panels	HEC42P3N	6	0.5	\$101	\$110	\$127
	For 50"H Panels	HEC50P3N	7	0.6	\$120	\$129	\$146
	For 57½"H Panels	HEC57P3N	8	0.8	\$128	\$137	\$154
	For 65"H Panels	HEC65P3N	8	0.8	\$134	\$143	\$160
	For 72½"H Panels	HEC72P3N	9	0.9	\$143	\$152	\$169
	For 80"H Panels	HEC80P3N	9	0.9	\$150	\$159	\$176
	Extended Straight Connector Posts						
	For 35"H Panels	HEC35PSN	6	0.5	\$89	\$98	\$115
	For 42½"H Panels	HEC42PSN	6	0.5	\$107	\$116	\$133
	For 50"H Panels	HEC50PSN	7	0.6	\$125	\$134	\$151
	For 57½"H Panels	HEC57PSN	8	0.8	\$133	\$142	\$159
	For 65"H Panels	HEC65PSN	8	0.8	\$140	\$149	\$166
	For 72½"H Panels	HEC72PSN	9	0.9	\$150	\$159	\$176
	For 80"H Panels	HEC80PSN	9	0.9	\$155	\$164	\$181
	"L" Connector Posts						
	For 35"H Panels	HEC35PLN	6	0.5	\$94	\$103	\$120
	For 42½"H Panels	HEC42PLN	6	0.5	\$112	\$121	\$138
	For 50"H Panels	HEC50PLN	7	0.6	\$130	\$139	\$156
	For 57½"H Panels	HEC57PLN	8	0.8	\$139	\$148	\$165
	For 65"H Panels	HEC65PLN	8	0.8	\$145	\$154	\$171
	For 72½"H Panels	HEC72PLN	9	0.9	\$153	\$162	\$179
	For 80"H Panels	HEC80PLN	9	0.9	\$160	\$169	\$186
	"T" Connector Posts						
	For 35"H Panels	HEC35PTN	6	0.5	\$89	\$98	\$115
	For 42½"H Panels	HEC42PTN	6	0.5	\$107	\$116	\$133
	For 50"H Panels	HEC50PTN	7	0.6	\$125	\$134	\$151
	For 57½"H Panels	HEC57PTN	8	0.8	\$133	\$142	\$159
	For 65"H Panels	HEC65PTN	8	0.8	\$140	\$149	\$166
	For 72½"H Panels	HEC72PTN	9	0.9	\$148	\$157	\$174
	For 80"H Panels	HEC80PTN	9	0.9	\$155	\$164	\$181
	"X" Connector Posts						
	For 35"H Panels	HEC35PXN	6	0.5	\$84	\$93	\$110
	For 42½"H Panels	HEC42PXN	6	0.5	\$101	\$110	\$127
	For 50"H Panels	HEC50PXN	7	0.6	\$120	\$129	\$146
	For 57½"H Panels	HEC57PXN	8	0.8	\$128	\$137	\$154
	For 65"H Panels	HEC65PXN	8	0.8	\$134	\$143	\$160
	For 72½"H Panels	HEC72PXN	9	0.9	\$143	\$152	\$169
	For 80"H Panels	HEC80PXN	9	0.9	\$150	\$159	\$176

NOTES:

- Specify connectors based on number and placement of panels.
- Connector posts are specified separately from connector straps — specify post to tallest panel and straps based on connection (see variable height example on straps page).
- Specify connector to fit height of tallest panel.
- Connectors are made of extruded aluminum.
- Straight Connector model HSCKTPS ships standard in bulk pack.
- Connector posts where power pole will enter need to be specified with single connector straps, model HECS1.

ⓘ In-line connector must be specified for all in-line connections.

ⓘ If adding to existing panels produced prior to 04/13/2016, please contact Customer Support for compatibility.

HOW TO SPECIFY

<p>Select Model Number</p>	<p>Select Paint Color</p> <p>See page 455</p>
<p>HEC35P2N</p>	<p>T3</p>

	DESCRIPTION	MODEL	SHIP WEIGHT	CUBE	LIST PRICE
	120° 2-Way Connector Strap	HECSV	1.4	0.2	\$21
	120° 3-Way Connector Strap	HECSY	2.2	0.2	\$26
	Extended Straight Connector Strap	HECSS	1.6	0.2	\$21
	"L" Connector Strap	HECSL	1.5	0.2	\$16
	"T" Connector Strap	HECST	2.3	0.2	\$21
	"X" Connector Strap	HECSX	3.0	0.2	\$26
	Single Connector Strap	HECSI	1.9	0.2	\$16
	In-line Connector NOTES: No need to specify finish. SPECIFYING EXAMPLE: HSCKTPS.X	HSCKTPS	0.5	0.1	\$19

NOTES:

- Strengthened Connection Straps provide more rigidity to panel connections, especially when not tied into a station with a worksurface or storage, i.e., when Coordinate™ Height Adjustable bases are used or when using panels strictly to divide space without tying in other components.
- Connector strap type should be specified based on the tallest panel connection type. Connector straps and posts are specified separately.
- Lower height panels will connect with variable height trim.
- See examples below.
- Connector straps can be retrofitted on any existing Accelerate® stations that were produced from April 2016 to present.
- Will fit on existing connector posts — only straps would need to be specified.
- Single Straps (HECSI) are used when power poles enter at the connector post and in variable height applications where the tallest panel is a single and one or more panels is lower.

Connector Post



New Connector Straps

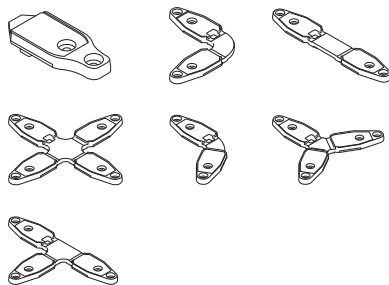

+

"T" 2 High, "L" 1 Low

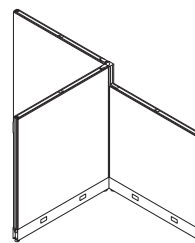

- 1 — "T" Connector Post
- 1 — VH Post Trim
- 3 — Top Caps
- 3 — End Caps
- 1 — "L" Connector Strap

"T" 1 High, "L" 2 Low

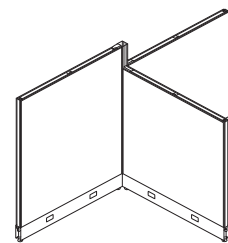

- 1 — "T" Connector Post
- 2 — VH Post Trim
- 3 — Top Caps
- 3 — End Caps
- 1 — Single Connector Strap

HOW TO SPECIFY

Select Model Number



Variable Height Finished End and Wall Starter Kits



DESCRIPTION	MODEL	SHIP WEIGHT	CUBE	LIST PRICE BY PAINT GRADE	
				P1	P2
Finished End Covers					
35"H	HEFEC35P	3	0.4	\$51	\$60
42½"H	HEFEC42P	3	0.5	\$54	\$63
50"H	HEFEC50P	4	0.6	\$58	\$67
57½"H	HEFEC57P	5	0.6	\$61	\$70
65"H	HEFEC65P	5	0.7	\$65	\$74
72½"H	HEFEC72P	6	0.8	\$70	\$79
80"H	HEFEC80P	6	0.9	\$73	\$82

NOTES: Finished End Covers include top bracket, end trim clips and end trim.



In-line Variable Height Finishing Kit					
7½"H	HEVHF07P	2	0.2	\$53	\$62
15"H	HEVHF15P	2	0.4	\$57	\$66
22½"H	HEVHF22P	3	0.4	\$67	\$76
30"H	HEVHF30P	3	0.4	\$79	\$88

NOTES: In-line Variable Height Finishing Kits include top and bottom bracket, end trim clips and end trim. In-line Variable Height Finishing Kit is used to connect a finished in-line panel connection.



Connector Variable Height Finishing Kit					
7½"H	HECVH07P	2	0.2	\$53	\$62
15"H	HECVH15P	2	0.4	\$57	\$66
22½"H	HECVH22P	3	0.4	\$67	\$76
30"H	HECVH30P	3	0.4	\$79	\$88

NOTES: Connector Variable Height Finishing Kits include top and bottom bracket, end trim and end trim connection piece.



Wall Starter Kit					
35"H	HEWS35P	4	0.4	\$86	\$95
42½"H	HEWS42P	4	0.5	\$91	\$100
50"H	HEWS50P	5	0.6	\$95	\$104
57½"H	HEWS57P	6	0.6	\$100	\$109
65"H	HEWS65P	6	0.7	\$107	\$116
72½"H	HEWS72P	7	0.8	\$114	\$123
80"H	HEWS80P	7	0.9	\$120	\$129

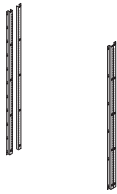

Permanent Wall Hanger Kit					
2½"W x 7/8"D x 66"H	HRVC35PCE	6	0.7	\$220	\$240
4¼"W x 7/8"D x 66"H	HRVC35PCM	3	0.7	\$115	\$125

⚠ Anchor devices are not supplied with this model. Refer to Abound® Installation instructions for appropriate hardware. Attachment to masonry walls is not recommended.

Specify paint

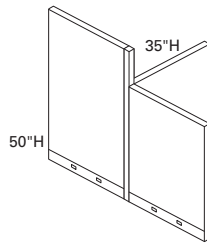

T-Connection Connector, Variable Height Finishing Kit

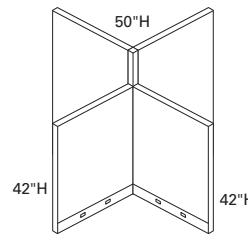

X-Connection Connector, Variable Height Finishing Kit

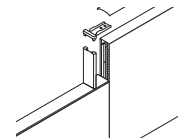

In-line Variable Height Trim Kit

NOTES:

- In-line Variable Height Finishing Kit is used to connect a finished in-line panel connection.
- Connector variable height finishing kit is used at a drop in height at an L, T, X, or S connection.
- All kits come with all hardware needed to install the kit.
- ⚠ Variable height kit needs to be specified any time a change of panel height occurs.
- ⚠ Finished end covers must be specified at all end of panel runs.
- ⚠ If adding to existing panels produced prior to 04/13/16, please contact Customer Support for compatibility.

HOW TO SPECIFY

<p>Select Model Number</p> <p>HEFEC35P</p>	<p>Select Paint Color</p> <p>See page 455</p> <p>T3</p>
--	---

ACCELERATE® Bracket Kits and Stability Feet

GSA SIN 33721



Icon Legend on page 19

WORKSTATIONS



DESCRIPTION

Accelerate® Anchor Bracket

Package of ten

NOTES: For use when panels need to be anchored to the floor such as high traffic areas or community spaces.

⚠ Only available in Black (P).

SPECIFYING EXAMPLE: HEABAC.P

MODEL

SHIP WEIGHT

CUBE

LIST PRICE

HEABAC

5 Ⓞ

0.08

\$85

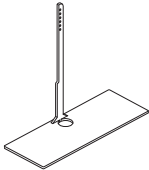

DESCRIPTION

Accelerate® Stability Foot

NOTES: Stabilizes bottom of panel from movement. Will not prohibit movement at top of panel.

MODEL

SHIP WEIGHT

CUBE

LIST PRICE BY PAINT GRADE

P1

P2

HEFTAC

3

0.1

\$374

\$384

NOTES:

- ⚠ The Anchor Bracket and Stability Foot are not intended to create a freestanding panel. Please follow Accelerate® stability standards.
- ⚠ Attachment hardware for floor anchor not included.

HOW TO SPECIFY

Select
Model Number

Select
Paint Color

See page 455

HEFTAC.

T1

EMPOWER®



Empower 2- and 4-Pack Benching Systems with Ignition® Seating, Voi® and Contain® Storage and Arrange® Tables.

EMPOWER®

Need a simple way to get up and running fast? No problem. Looking to expand and customize workstations for a growing business? Empower does that, too. With Empower benching, you've got the power to do more. Offer more personal space. Enjoy more adaptability. Route power more efficiently. It's simple to order, easy to install and quick to reconfigure. When you Empower your people, you keep pace with the changing demands of today's workplace.



FEATURES

- With numerous laminate selections to choose from, it's easy to get the exact look you want.
- Integrated height adjustability supports the work style of any user.
- Frosted glass. Colorful fabrics. Magnetic metal. Empower screens add style, privacy and functionality.
- Choose from multiple paint finishes to blend in or stand out.
- As the main electrical artery, power and data cables are laid into the trough.
- Plug power modules into the duplex in the trough and attach them to the worksurface for easy access to electrical and USB ports.
- Power entry can be accommodated through the ceiling, floor, or wall.
- Keep cords collected and controlled from floor to wire trough with vertebra.
- Support any work style by adding HON pedestals, credenzas and storage towers to Empower benching.

EMPOWER[®] FABRIC SCREENS — ALL PANEL MODELS

PRICE CODE AA

FACTOR	FACT
◆ Bark	FACT20
◆ Barley	FACT15
◆ Cascade	FACT25
◆ Feather	FACT30

PRICE CODE A

APPOINT	APN
◆ Artichoke	APN11
◆ Blackberry	APN32
◆ Bronze	APN22
◆ Carbon	APN28
◆ Chai	APN12
◆ Cherry	APN30
◆ Dark Pewter	APN17
◆ Dune	APN15
◆ Espresso	APN23
◆ Framboise	APN31
◆ Frost	APN34
◆ Jet	APN27
◆ Lawn	APN25
◆ Mandarin	APN29
◆ Morel	APN09
◆ Nimbus	APN16
◆ Platinum	APN24
◆ Turquoise	APN26

CENTURION CU

◆ Apricot	CU47
◆ Bark	CU25
◆ Black	CU10
◆ Espresso	CU49
◆ Fog	CU03
◆ Frost	CU22
◆ Goldenrod	CU27
◆ Indigo	CU06
◆ Iris	CU50
◆ Iron Ore	CU19
◆ Jade	CU83
◆ Marsala	CU63
◆ Morel	CU24
◆ Navy	CU98
◆ Peacock	CU97
◆ Pear	CU84
◆ Ruby	CU67
◆ Sapphire	CU09

PRICE CODE A *continued*

ETCH*	ECH
◆ Axis	ECH13
◆ Blend	ECH14
◆ Cast	ECH12
◆ Highlight	ECH10
◆ Midtone	ECH11
◆ Outline	ECH08
◆ Shade	ECH09
◆ Tonal	ECH16
◆ Vanish	ECH15

EXCHANGE* EXG

◆ Iron	EXG916
◆ Nickel	EXG914
◆ Pistachio	EXG910
◆ Root	EXG913
◆ Rupee	EXG903
◆ Shadow	EXG911
◆ Silver	EXG915
◆ Sisal	EXG917
◆ Stone	EXG912

LANDSCAPE* LN

◆ Azure	LN55
◆ Cornsilk	LN15
◆ Drift	LN05
◆ Khaki	LN20
◆ Sheen	LN10
◆ Slate	LN35
◆ Umber	LN25
◆ Urban	LN30

LUCY* LC

◆ Aspen	LC32
◆ Cornsilk	LC30
◆ Dusk	LC22
◆ Fawn	LC33
◆ Graphite	LC34
◆ Mist	LC20
◆ Neutra	LC24
◆ Pewter	LC35
◆ Snowdrop	LC28

PRICE CODE A *continued*

REFLECTIONS*	REF
◆ Galvanized	REF29
◆ Ice	REF20
◆ Loggia	REF21
◆ Mistral	REF28
◆ Moonstone	REF23
◆ Pewter	REF22
◆ Stainless	REF24
◆ Vanilla	REF25
◆ Winter	REF27

REFUGE* RFG

◆ Artesian	RFG96
◆ Dune	RFG92
◆ Eclipse	RFG90
◆ Frost	RFG93
◆ Glacier	RFG91
◆ Mineral	RFG98
◆ Tidal	RFG94

SARTO* SRT

◆ Ash	SRT88
◆ Fog	SRT14
◆ Lemongrass	SRT49
◆ Mist	SRT45
◆ Mushroom	SRT76
◆ Oyster	SRT18
◆ Reef	SRT64
◆ Sesame	SRT93
◆ Shale	SRT52

TEMPEST* TP

◆ Dragonfly	TP30
◆ Frost	TP15
◆ Full Stream	TP80
◆ Gold Rush	TP10
◆ Slate	TP45
◆ Tumbleweed	TP70
◆ Wind Chill	TP40
◆ Zebra	TP35

NOTES: Analog, Disperse, and Exchange panel fabrics will be applied pattern cut. Disperse will not be available on 72"W panels.

◆◆◆ For lead time information see page 19.

* Directional fabrics

EMPOWER® FABRIC SCREENS — ALL PANEL MODELS

PRICE CODE B

ANALOG*	ANLG
◆ Album	ANLG06
◆ Cartridge	ANLG04
◆ Cassette	ANLG09
◆ Dial	ANLG02
◆ Media	ANLG08
◆ Reel	ANLG07
◆ Signal	ANLG03
◆ Stereo	ANLG01
◆ Track	ANLG05

COAST*

COAST*	COA
◆ Channel	COA14
◆ Dune	COA03
◆ Headlands	COA10
◆ Marsh	COA02
◆ Pebble	COA12
◆ Pier	COA13
◆ Shoal	COA01
◆ Silt	COA06
◆ Tide	COA08

DISPERSE*

DISPERSE*	DISP
◆ Autumn	DISP03
◆ Branch	DISP10
◆ Coffee Bean	DISP13
◆ Dusk	DISP09
◆ Emerald City	DISP08
◆ Gold Rush	DISP02
◆ Igloo	DISP11
◆ Ink	DISP06
◆ Mist	DISP12
◆ Oatmeal	DISP15
◆ Prince	DISP07
◆ Reservoir	DISP01
◆ Rose	DISP04
◆ Spring	DISP05
◆ Steel	DISP16
◆ Taupe	DISP14

PRICE CODE B *continued*

MICA*	MCA
◆ Anthracite	MCA11
◆ Breeze	MCA18
◆ Bronze	MCA13
◆ Buff	MCA14
◆ Cremini	MCA17
◆ Crystal	MCAWIT
◆ Dew	MCA20
◆ Dove	MCA12
◆ Fresh	MCA16
◆ Mineral	MCA15
◆ Nectar	MCA19
◆ Shale	MCA10

PRICE CODE B *continued*

SPIN*	SPIN
◆ Alabaster	SPIN02
◆ Cavern	SPIN03
◆ Cobblestone	SPIN04
◆ Ember	SPIN06
◆ Flame	SPIN07
◆ Heron	SPIN13
◆ Oat	SPIN01
◆ Ocean	SPIN12
◆ Plum	SPIN15
◆ Pool	SPIN11
◆ Raven	SPIN10
◆ Rhubarb	SPIN14
◆ Tropic	SPIN08
◆ Willow	SPIN05

PRICE CODE B *continued*

TERRAIN*	TRRN
◆ Bay	TRRN05
◆ Bayou	TRRN35
◆ Canyon	TRRN30
◆ Cliff	TRRN45
◆ Crest	TRRN25
◆ Delta	TRRN10
◆ Plateau	TRRN15
◆ Ridge	TRRN20
◆ Valley	TRRN40

NOTES: Analog, Disperse, and Exchange panel fabrics will be applied pattern cut. Disperse will not be available on 72"W panels.

◆◆◆ For lead time information see page 19.

* Directional fabrics

EMPOWER® FINISH OPTIONS

WORKSURFACES

L1 LAMINATES CODES

- Woodgrain**
- ◆ Bourbon Cherry H
 - ◆ Cognac COGN
 - ◆ Florence Walnut LFW1
 - ◆ Harvest C
 - ◆ Kingswood Walnut LK11
 - ◆ Mahogany N
 - ◆ Mocha MOCH
 - ◆ Natural Maple D
 - ◆ Pinnacle PINC
 - ◆ Shaker Cherry F
 - ◆ Sterling Ash LSA1

- Solid**
- ◆ Black P
 - ◆ Charcoal S
 - ◆ Designer White LDW1
 - ◆ Loft LOFT

- Patterned**
- ◆ Canyon Zephyr K9
 - ◆ Desert Zephyr K8
 - ◆ Gray G2
 - ◆ Grey Tigris L6
 - ◆ Shadow Zephyr K1
 - ◆ Sheer Mesh A5
 - ◆ Silver Mesh B9
 - ◆ Steel Mesh A9
 - ◆ White G1
 - ◆ Whitestone K4

L2 LAMINATES CODES

- Woodgrain**
- ◆ Lowell Ash LLA1
 - ◆ Natural Recon LNR1
 - ◆ Phantom Ecru LPE1
 - ◆ Portico Teak LPT1
 - ◆ Skyline Walnut LSW1

WORKSURFACE EDGE BAND

- Woodgrain**
- ◆ Bourbon Cherry H
 - ◆ Cognac COGN
 - ◆ Florence Walnut FW
 - ◆ Harvest C
 - ◆ Kingswood Walnut KI
 - ◆ Lowell Ash DL
 - ◆ Mahogany N
 - ◆ Mocha MOCH
 - ◆ Natural Maple D
 - ◆ Natural Recon NR
 - ◆ Phantom Ecru PE
 - ◆ Pinnacle PINC
 - ◆ Portico Teak DP
 - ◆ Shaker Cherry F
 - ◆ Skyline Walnut SW
 - ◆ Sterling Ash SA

- Solid**
- ◆ Black P
 - ◆ Charcoal S
 - ◆ Designer White LDW1
 - ◆ Greige R
 - ◆ Loft LOFT
 - ◆ Muslin T
 - ◆ Platinum K
 - ◆ Shadow * SHDW

END OF RUN SCREENS

L1 LAMINATES CODES

- Woodgrain**
- ◆ Bourbon Cherry H
 - ◆ Cognac COGN
 - ◆ Florence Walnut LFW1
 - ◆ Harvest C
 - ◆ Kingswood Walnut LK11
 - ◆ Mahogany N
 - ◆ Mocha MOCH
 - ◆ Natural Maple D
 - ◆ Pinnacle PINC
 - ◆ Shaker Cherry F
 - ◆ Sterling Ash LSA1

- Solid**
- ◆ Black P
 - ◆ Charcoal S
 - ◆ Designer White LDW1
 - ◆ Loft LOFT

- Patterned**
- ◆ Sheer Mesh A5
 - ◆ Silver Mesh B9

L2 LAMINATES CODES

- Woodgrain**
- ◆ Lowell Ash LLA1
 - ◆ Natural Recon LNR1
 - ◆ Phantom Ecru LPE1
 - ◆ Portico Teak LPT1
 - ◆ Skyline Walnut LSW1

STATIC LEGS AND TROUGHS

PAINTS CODES

- P1**
- ◆ Black P
 - ◆ Brownstone P7D
 - ◆ Charcoal S
 - ◆ Designer White PJW
 - ◆ Fossil P28
 - ◆ Greige T5
 - ◆ Light Gray Q
 - ◆ Loft LOFT
 - ◆ Muslin T3
 - ◆ Putty L
 - ◆ Shadow * SHDW
 - ◆ Titanium P8T

- P2**
- ◆ Champagne Metallic T4
 - ◆ Platinum Metallic T1
 - ◆ Silver PR6
 - ◆ Solar Black P8X

- P3**
- ◆ Atom P8S
 - ◆ Bullseye PJF
 - ◆ Ember P8P
 - ◆ Ion P8N
 - ◆ Iris P8J
 - ◆ Krypton P8F
 - ◆ Regatta P8M

POWER POLE

PAINTS CODES

- P1**
- ◆ Black P
 - ◆ Charcoal S
 - ◆ Designer White PJW
 - ◆ Greige T5
 - ◆ Light Gray Q
 - ◆ Loft LOFT
 - ◆ Muslin T3
 - ◆ Shadow * SHDW

PAINTED METAL SCREENS AND SCREEN BRACKETS

PAINTS CODES

- P1**
- ◆ Black P
 - ◆ Brownstone P7D
 - ◆ Charcoal S
 - ◆ Designer White PJW
 - ◆ Fossil P28
 - ◆ Greige T5
 - ◆ Light Gray Q
 - ◆ Loft LOFT
 - ◆ Muslin T3
 - ◆ Putty L
 - ◆ Shadow * SHDW
 - ◆ Titanium P8T

- P2**
- ◆ Champagne Metallic T4
 - ◆ Platinum Metallic T1
 - ◆ Silver PR6
 - ◆ Solar Black P8X
 - ◆ White Markerboard MKB

- P3**
- ◆ Atom P8S
 - ◆ Bullseye PJF
 - ◆ Ember P8P
 - ◆ Ion P8N
 - ◆ Iris P8J
 - ◆ Krypton P8F
 - ◆ Regatta P8M

Recommended Color to use with Duplex and Data Electric Kits

Paint	Duplex-Data Code
Black P	Black P
Brownstone P7D	Brownstone EY
Charcoal S	Charcoal S
Designer White PJW	Designer White DW
Fossil P28	Charcoal S
Greige T5	Muslin T3
Light Gray Q	Loft LOFT
Loft LOFT	Loft LOFT
Muslin T3	Muslin T3
Putty L	Black P
Shadow SHDW	Muslin T3
Silver PR6	Titanium T1
Titanium P8T	Titanium T1
Champagne Metallic T4	Muslin T3
Platinum Metallic T1	Titanium T1

WORKSURFACE LAMINATES	CODES	EDGE BAND OPTIONS						
		Matching Edge	Designer White (DW)	Loft (LOFT)	Muslin (T)	Shadow (SHDW)	Black (P)	Charcoal (S)
Black	P						•	
Bourbon Cherry	H	•	•		•			
Charcoal	S							•
Cognac	COGN	•	•		•			
Designer White	LDW1		•					
Harvest	C	•	•		•			
Loft	LOFT			•				
Lowell Ash	LLA1	•	•	•	•			
Mahogany	N	•		•		•		
Mocha	MOCH	•	•		•			
Natural Maple	D	•	•	•	•			
Natural Recon	LNR1	•	•	•	•			
Phantom Ecru	LPE1	•	•	•	•			
Pinnacle	PINC	•	•		•			
Portico Teak	LPT1	•	•	•	•			
Shaker Cherry	F	•	•	•	•	•		
Sheer Mesh	A5				•			
Silver Mesh	B9			•				
Skyline Walnut	LSW1	•	•	•	•			
Sterling Ash	LSA1	•	•	•			•	

◆◆◆ For lead time information see page 19.
* De-emphasized

EMPOWER[®] Step-by-Step Guide

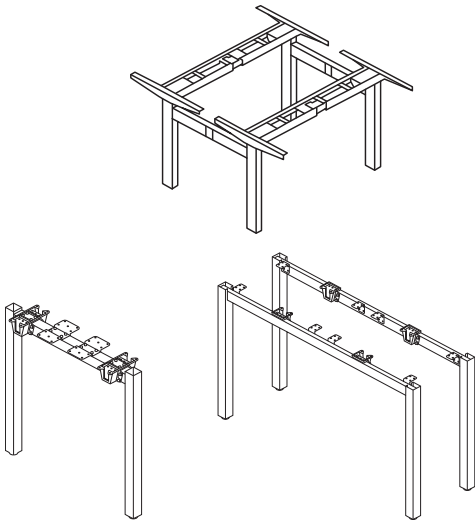

STEP 1: LEGS

All necessary brackets ship attached to the legs.

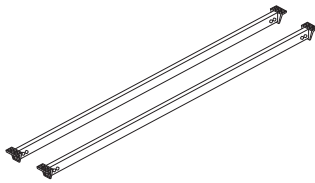

STEP 2: SUPPORT BEAMS (STATIC ONLY)

All necessary brackets ship attached to the beam. Simply fasten to the legs with the provided screws.

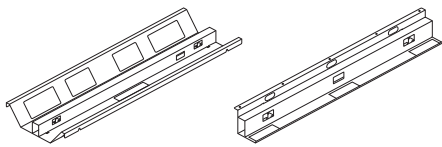

STEP 3: TROUGHS

Slide the trough over the support beams for double-sided. Screw the trough into the surface for single-sided.

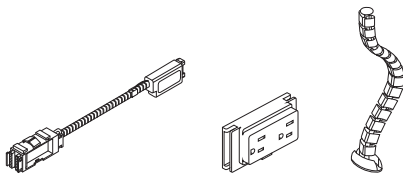

STEP 4: ELECTRICAL

Slide 8-wire harnesses/duplexes into pre-installed clips on the trough. Lay in data if necessary and cover.

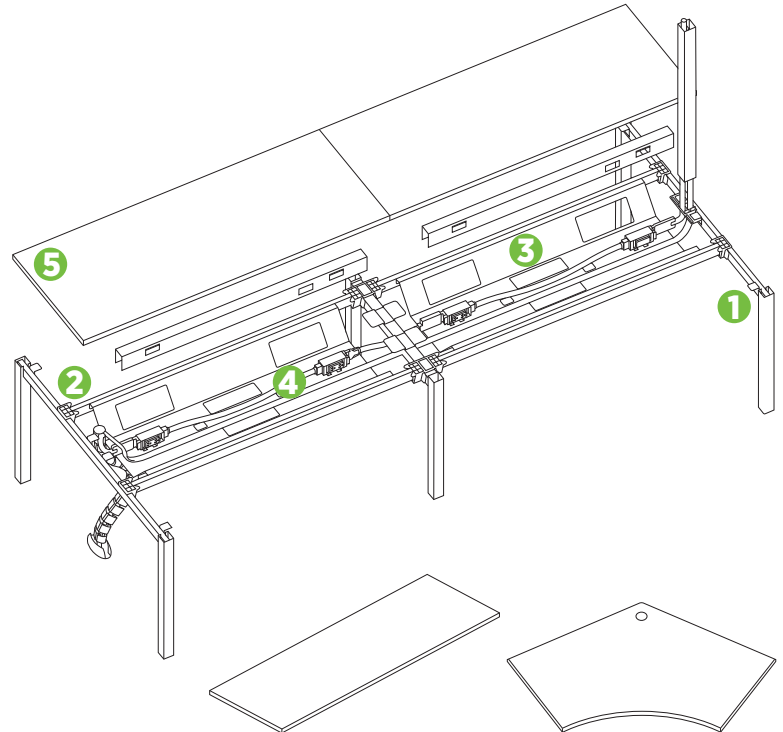

STEP 5: WORKSURFACES

All necessary brackets ship attached to the beam. Simply fasten to the legs with the provided screws.

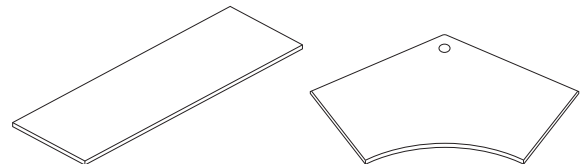

STEP 6: SCREENS

Drop shared screens into installed brackets, slide side screens into place or attach end of run screens at end of worksurfaces.

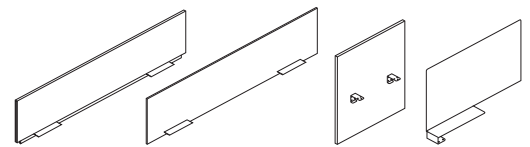

STEP 7: STORAGE

Choose your storage, from pedestals, to credenzas to towers — whatever suits your needs.

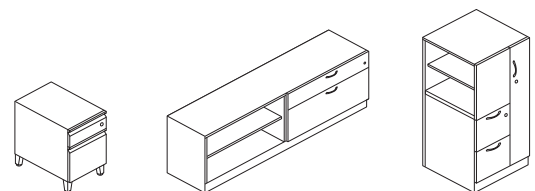

EMPOWER®

72"W Typical with 24"D Worksurfaces



Icon Legend on page 19

WORKSTATIONS

QTY	DESCRIPTION	MODEL	LIST PRICE	PRICE EXTENSION
2	Worksurface, Edgeband, No Grommets 24" x 72"	HWR2472PN	\$529	\$1,058
1	Double Depth U-Leg (Box of 2)	HMPEL4828	\$1,136	\$1,136
1	Support Beams (Box of 2) 72"W	HMPUB272	\$704	\$704
1	Shared Trough 72"W	HMPROUGH72	\$479	\$479
1	End of Run Electrical Kit 72"W	HMPEEK72	\$225	\$225
1	Duplex 1	HH871501	\$42	\$42
1	Duplex 2	HH871502	\$42	\$42
1	Duplex 3	HH871503	\$42	\$42
1	Duplex 4	HH871504	\$42	\$42
TOTAL:			\$3,770	

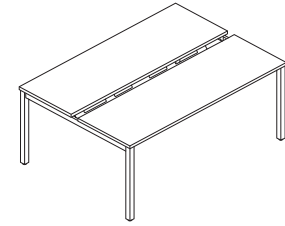

**2-PACK — 72"
72"W x 51"D**

QTY	DESCRIPTION	BUNDLE SKU	LIST PRICE
1	2-PACK BUNDLE Includes all Components Listed Above	HMP2472PK2	\$3,770

SPECIFYING EXAMPLE: Model.Laminate.Edgeband.Paint2.DuplexColor

NOTES: Typical DO NOT include power in-feeds, screens, storage, or seating.

ADD 1 FABRIC SCREEN: \$727— SEE PAGE 509

ADD 2 MOBILE PEDESTALS: \$1,170— SEE PAGE 543

SEE PAGE 512 FOR BUNDLE SKU INFORMATION

QTY	DESCRIPTION	MODEL	LIST PRICE	PRICE EXTENSION
4	Worksurface, Edgeband, No Grommets 24" x 72"	HWR2472PN	\$529	\$2,116
1	Double Depth U-Leg (Box of 2)	HMPEL4828	\$1,136	\$1,136
1	Double Depth Shared U-Leg (Singles)	HMPSL4828	\$468	\$468
2	Support Beams (Box of 2) 72"W	HMPUB272	\$704	\$1,408
2	Shared Trough 72"W	HMPROUGH72	\$479	\$958
1	Power Harness 72"W	HH871272	\$216	\$216
1	End of Run Electrical Kit 72"W	HMPEEK72	\$225	\$225
2	Duplex 1	HH871501	\$42	\$84
2	Duplex 2	HH871502	\$42	\$84
2	Duplex 3	HH871503	\$42	\$84
2	Duplex 4	HH871504	\$42	\$84
TOTAL:			\$6,863	

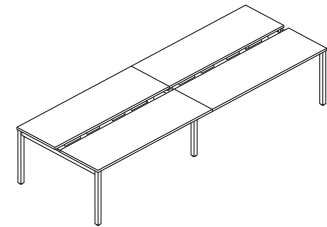

**4-PACK — 72"
144"W x 51"D**

QTY	DESCRIPTION	BUNDLE SKU	LIST PRICE
1	4-PACK BUNDLE Includes all Components Listed Above	HMP2472PK4	\$6,863

SPECIFYING EXAMPLE: Model.Laminate.Edgeband.Paint2.DuplexColor

NOTES: Typical DO NOT include power in-feeds, screens, storage, or seating.

ADD 2 FABRIC SCREENS: \$1,454— SEE PAGE 509

ADD 4 MOBILE PEDESTALS: \$2,340— SEE PAGE 543

SEE PAGE 512 FOR BUNDLE SKU INFORMATION



Icon Legend on page 19

EMPOWER[®]

72"W Typicals with 24"D Worksurfaces

WORKSTATIONS

QTY	DESCRIPTION	MODEL	LIST PRICE	PRICE EXTENSION
6	Worksurface, Edgeband, No Grommets 24" x 72"	HWR2472PN	\$529	\$3,174
1	Double Depth U-Leg (Box of 2)	HMPEL4828	\$1,136	\$1,136
2	Double Depth Shared U-Leg (Singles)	HMPSL4828	\$468	\$936
3	Support Beams (Box of 2) 72"W	HMPUB272	\$704	\$2,112
3	Shared Trough 72"W	HMPROUGH72	\$479	\$1,437
2	Power Harness 72"W	HH871272	\$216	\$432
1	End of Run Electrical Kit 72"W	HMPEEK72	\$225	\$225
3	Duplex 1	HH871501	\$42	\$126
3	Duplex 2	HH871502	\$42	\$126
3	Duplex 3	HH871503	\$42	\$126
3	Duplex 4	HH871504	\$42	\$126
TOTAL:				\$9,956

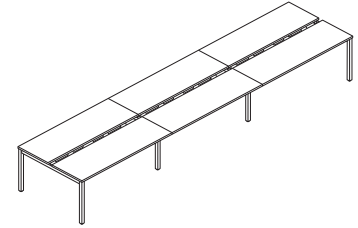

6-PACK — 72"
216"W x 51"D

QTY	DESCRIPTION	BUNDLE SKU	LIST PRICE
1	6-PACK BUNDLE Includes all Components Listed Above	HMP2472PK6	\$9,956

SPECIFYING EXAMPLE: Model.Laminate.Edgeband.Paint2.DuplexColor

NOTES: Typicals DO NOT include power in-feeds, screens, storage, or seating.

ADD 3 FABRIC SCREENS: \$2,181 — SEE PAGE 509

ADD 6 MOBILE PEDESTALS: \$3,510 — SEE PAGE 543

SEE PAGE 512 FOR BUNDLE SKU INFORMATION

QTY	DESCRIPTION	MODEL	LIST PRICE	PRICE EXTENSION
8	Worksurface, Edgeband, No Grommets 24" x 72"	HWR2472PN	\$529	\$4,232
1	Double Depth U-Leg (Box of 2)	HMPEL4828	\$1,136	\$1,136
3	Double Depth Shared U-Leg (Singles)	HMPSL4828	\$468	\$1,404
4	Support Beams (Box of 2) 72"W	HMPUB272	\$704	\$2,816
4	Shared Trough 72"W	HMPROUGH72	\$479	\$1,916
3	Power Harness 72"W	HH871272	\$216	\$648
1	End of Run Electrical Kit 72"W	HMPEEK72	\$225	\$225
4	Duplex 1	HH871501	\$42	\$168
4	Duplex 2	HH871502	\$42	\$168
4	Duplex 3	HH871503	\$42	\$168
4	Duplex 4	HH871504	\$42	\$168
TOTAL:				\$13,049

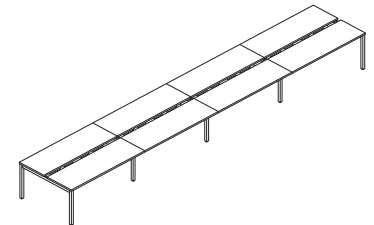

8-PACK — 72"
288"W x 51"D

QTY	DESCRIPTION	BUNDLE SKU	LIST PRICE
1	8-PACK BUNDLE Includes all Components Listed Above	HMP2472PK8	\$13,049

SPECIFYING EXAMPLE: Model.Laminate.Edgeband.Paint2.DuplexColor

NOTES: Typicals DO NOT include power in-feeds, screens, storage, or seating.

ADD 4 FABRIC SCREENS: \$2,908 — SEE PAGE 509

ADD 8 MOBILE PEDESTALS: \$4,680 — SEE PAGE 543

SEE PAGE 512 FOR BUNDLE SKU INFORMATION

EMPOWER[®] 72"W Typicals with 24"D Worksurfaces



Icon Legend on page 19

WORKSTATIONS

QTY	DESCRIPTION	MODEL	LIST PRICE	PRICE EXTENSION
2	Electrical Power Harness Panels w/Duplex Capacity	HH871272	\$216	\$432
1	End of Run Electrical Kit 72"W	HMPPEEK72	\$225	\$225
1	Duplex Receptacle Circuit 1 3-1 & 2-2 Systems	HH871501	\$42	\$42
1	Duplex Receptacle Circuit 2 3-1 & 2-2 Systems	HH871502	\$42	\$42
1	Duplex Receptacle Circuit 3 3-1 System Only	HH871503	\$42	\$42
3	Duplex Receptacle Circuit 4 3-1 & 2-2 Systems	HH871504	\$42	\$126
1	Single Depth U-Leg (Box of 2)	HMPPEL2428	\$567	\$567
1	Single Depth Return Leg — Left	HMPRLEL2428	\$345	\$345
2	Single Depth Return Leg — Right	HMPRREL2428	\$345	\$690
2	Single Depth Shared U-Leg (Singles)	HMPSL2428	\$345	\$690
3	Single-Side Trough 72"W	HMPSTROUGH72	\$509	\$1,527
2	Support Beams (Box of 1) 48"W	HMPUB148	\$286	\$572
1	Support Beams (Box of 1) 60"W	HMPUB160	\$319	\$319
3	Support Beams (Box of 1) 72"W	HMPUB172	\$353	\$1,059
2	Systems Rectangular Worksurface, Edgeband, No Grommets 24"D x 36"W	HWR2436PN	\$346	\$692
1	Systems Rectangular Worksurface, Edgeband, No Grommets 24"D x 48"W	HWR2448PN	\$404	\$404
3	Systems Rectangular Worksurface, Edgeband, No Grommets 24"D x 72"W	HWR2472PN	\$529	\$1,587
TOTAL:			\$9,361	

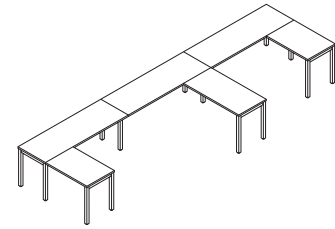

**6-PACK W/RETURNS — 72"
216"W x 72"D**

NOTES: Typicals DO NOT include power in-feeds, screens, storage, or seating.

ADD 3 FABRIC SCREENS: \$1,974 — SEE PAGE 509

ADD 3 MOBILE PEDESTALS: \$1,755 — SEE PAGE 543

SEE PAGE 512 FOR BUNDLE SKU INFORMATION

QTY	DESCRIPTION	MODEL	LIST PRICE	PRICE EXTENSION
2	Electrical Power Harness Panels w/Duplex Capacity	HH871272	\$216	\$432
1	End of Run Electrical Kit 72"W	HMPPEEK72	\$225	\$225
3	Duplex Receptacle Circuit 1 3-1 & 2-2 Systems	HH871501	\$42	\$126
3	Duplex Receptacle Circuit 2 3-1 & 2-2 Systems	HH871502	\$42	\$126
3	Duplex Receptacle Circuit 3 3-1 System Only	HH871503	\$42	\$126
3	Duplex Receptacle Circuit 4 3-1 & 2-2 Systems	HH871504	\$42	\$126
1	Double Depth U-Leg (Box of 2)	HMPPEL4828	\$1,136	\$1,136
2	Single Depth Return Leg — Left	HMPRLEL2428	\$345	\$690
2	Single Depth Return Leg — Right	HMPRREL2428	\$345	\$690
2	Double Depth Shared U-Leg (Singles)	HMPSL4828	\$468	\$936
3	Shared Trough 72"W	HMPSTROUGH72	\$479	\$1,437
3	Support Beams (Box of 1) 48"W	HMPUB148	\$286	\$858
1	Support Beams (Box of 1) 60"W	HMPUB160	\$319	\$319
3	Support Beams (Box of 2) 72"W	HMPUB272	\$704	\$2,112
3	Systems Rectangular Worksurface, Edgeband, No Grommets 24"D x 36"W	HWR2436PN	\$346	\$1,038
1	Systems Rectangular Worksurface, Edgeband, No Grommets 24"D x 48"W	HWR2448PN	\$404	\$404
6	Systems Rectangular Worksurface, Edgeband, No Grommets 24"D x 72"W	HWR2472PN	\$529	\$3,174
TOTAL:			\$13,955	

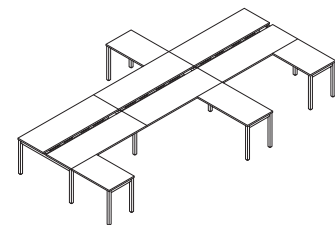

**3-PACK W/RETURNS — 72"
216"W x 132"D**

NOTES: Typicals DO NOT include power in-feeds, screens, storage, or seating.

ADD 3 FABRIC SCREENS: \$2,181 — SEE PAGE 509

ADD 6 MOBILE PEDESTALS: \$3,510 — SEE PAGE 543

SEE PAGE 512 FOR BUNDLE SKU INFORMATION



Icon Legend on page 19

EMPOWER[®]

60"W Typicals with 24"D Worksurfaces

QTY	DESCRIPTION	MODEL	LIST PRICE	PRICE EXTENSION
2	Worksurface, Edgeband, No Grommets 24" x 60"	HWR2460PN	\$477	\$954
1	Double Depth U-Leg (Box of 2)	HMPEL4828	\$1,136	\$1,136
1	Support Beams (Box of 2) 60"W	HMPUB260	\$635	\$635
1	Shared Trough 60"W	HMPROUGH60	\$436	\$436
1	End of Run Electrical Kit 60"W	HMPEEK60	\$225	\$225
1	Duplex 1	HH871501	\$42	\$42
1	Duplex 2	HH871502	\$42	\$42
1	Duplex 3	HH871503	\$42	\$42
1	Duplex 4	HH871504	\$42	\$42
TOTAL:			\$3,554	

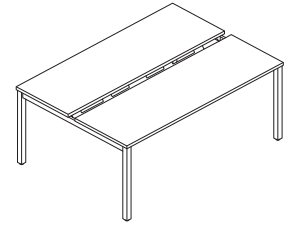

2-PACK — 60"
60"W x 51"D

QTY	DESCRIPTION	BUNDLE SKU	LIST PRICE
1	2-PACK BUNDLE Includes all Components Listed Above	HMP2460PK2	\$3,554

SPECIFYING EXAMPLE: Model.Laminate.Edgeband.Paint2.DuplexColor

NOTES: Typicals DO NOT include power in-feeds, screens, storage, or seating.

ADD 1 FABRIC SCREEN: \$656 — SEE PAGE 509

ADD 2 MOBILE PEDESTALS: \$1,170 — SEE PAGE 543

SEE PAGE 512 FOR BUNDLE SKU INFORMATION

QTY	DESCRIPTION	MODEL	LIST PRICE	PRICE EXTENSION
4	Worksurface, Edgeband, No Grommets 24" x 60"	HWR2460PN	\$477	\$1,908
1	Double Depth U-Leg (Box of 2)	HMPEL4828	\$1,136	\$1,136
1	Double Depth Shared U-Leg (Singles)	HMPSL4828	\$468	\$468
2	Support Beams (Box of 2) 60"W	HMPUB260	\$635	\$1,270
2	Shared Trough 60"W	HMPROUGH60	\$436	\$872
1	Power Harness 60"W	HH871260	\$216	\$216
1	End of Run Electrical Kit 60"W	HMPEEK60	\$225	\$225
2	Duplex 1	HH871501	\$42	\$84
2	Duplex 2	HH871502	\$42	\$84
2	Duplex 3	HH871503	\$42	\$84
2	Duplex 4	HH871504	\$42	\$84
TOTAL:			\$6,431	

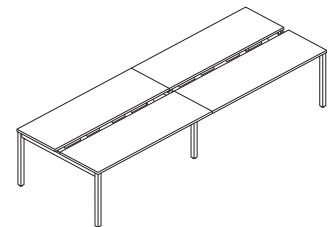

4-PACK — 60"
144"W x 51"D

QTY	DESCRIPTION	BUNDLE SKU	LIST PRICE
1	4-PACK BUNDLE Includes all Components Listed Above	HMP2460PK4	\$6,431

SPECIFYING EXAMPLE: Model.Laminate.Edgeband.Paint2.DuplexColor

NOTES: Typicals DO NOT include power in-feeds, screens, storage, or seating.

ADD 2 FABRIC SCREENS: \$1,312 — SEE PAGE 509

ADD 4 MOBILE PEDESTALS: \$2,340 — SEE PAGE 543

SEE PAGE 512 FOR BUNDLE SKU INFORMATION

EMPOWER®

60"W Typicals with 24"D Worksurfaces



Icon Legend on page 19

WORKSTATIONS

QTY	DESCRIPTION	MODEL	LIST PRICE	PRICE EXTENSION
6	Worksurface, Edgeband, No Grommets 24" x 60"	HWR2460PN	\$477	\$2,862
1	Double Depth U-Leg (Box of 2)	HMPEL4828	\$1,136	\$1,136
2	Double Depth Shared U-Leg (Singles)	HMPSL4828	\$468	\$936
3	Support Beams (Box of 2) 60"W	HMPUB260	\$635	\$1,905
3	Shared Trough 60"W	HMPTROUGH60	\$436	\$1,308
2	Power Harness 60"W	HH871260	\$216	\$432
1	End of Run Electrical Kit 60"W	HMPEEK60	\$225	\$225
3	Duplex 1	HH871501	\$42	\$126
3	Duplex 2	HH871502	\$42	\$126
3	Duplex 3	HH871503	\$42	\$126
3	Duplex 4	HH871504	\$42	\$126
TOTAL:				\$9,308

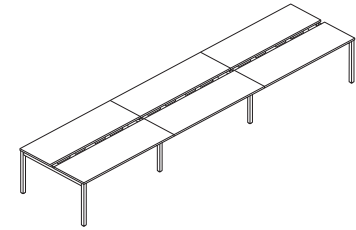

**6-PACK — 60"
180"W x 51"D**

QTY	DESCRIPTION	BUNDLE SKU	LIST PRICE
1	6-PACK BUNDLE Includes all Components Listed Above	HMP2460PK6	\$9,308

SPECIFYING EXAMPLE: Model.Laminate.Edgeband.Paint2.DuplexColor

NOTES: Typicals DO NOT include power in-feeds, screens, storage, or seating.

ADD 3 FABRIC SCREENS: \$1,968 — SEE PAGE 509

ADD 6 MOBILE PEDESTALS: \$3,510 — SEE PAGE 543

SEE PAGE 512 FOR BUNDLE SKU INFORMATION

QTY	DESCRIPTION	MODEL	LIST PRICE	PRICE EXTENSION
8	Worksurface, Edgeband, No Grommets 24" x 60"	HWR2460PN	\$477	\$3,816
1	Double Depth U-Leg (Box of 2)	HMPEL4828	\$1,136	\$1,136
3	Double Depth Shared U-Leg (Singles)	HMPSL4828	\$468	\$1,404
4	Support Beams (Box of 2) 60"W	HMPUB260	\$635	\$2,540
4	Shared Trough 60"W	HMPTROUGH60	\$436	\$1,744
3	Power Harness 60"W	HH871260	\$216	\$648
1	End of Run Electrical Kit 60"W	HMPEEK60	\$225	\$225
4	Duplex 1	HH871501	\$42	\$168
4	Duplex 2	HH871502	\$42	\$168
4	Duplex 3	HH871503	\$42	\$168
4	Duplex 4	HH871504	\$42	\$168
TOTAL:				\$12,185

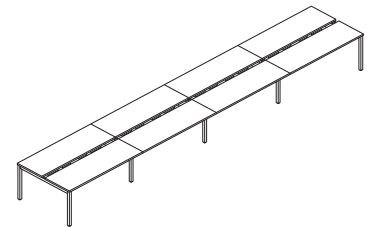

**8-PACK — 60"
240"W x 51"D**

QTY	DESCRIPTION	BUNDLE SKU	LIST PRICE
1	8-PACK BUNDLE Includes all Components Listed Above	HMP2460PK8	\$12,185

SPECIFYING EXAMPLE: Model.Laminate.Edgeband.Paint2.DuplexColor

NOTES: Typicals DO NOT include power in-feeds, screens, storage, or seating.

ADD 4 FABRIC SCREENS: \$2,624 — SEE PAGE 509

ADD 8 MOBILE PEDESTALS: \$4,680 — SEE PAGE 543

SEE PAGE 512 FOR BUNDLE SKU INFORMATION



Icon Legend on page 19

QTY	DESCRIPTION	MODEL	LIST PRICE	PRICE EXTENSION
2	Worksurface, Edgeband, No Grommets 30" x 72"	HWR3072PN	\$593	\$1,186
1	Double Depth U-Leg (Box of 2)	HMPEL6028	\$1,249	\$1,249
1	Support Beams (Box of 2) 72"W	HMPUB272	\$704	\$704
1	Shared Trough 72"W	HMPROUGH72	\$479	\$479
1	End of Run Electrical Kit 72"W	HMPEEK72	\$225	\$225
1	Duplex 1	HH871501	\$42	\$42
1	Duplex 2	HH871502	\$42	\$42
1	Duplex 3	HH871503	\$42	\$42
1	Duplex 4	HH871504	\$42	\$42
TOTAL:			\$4,011	

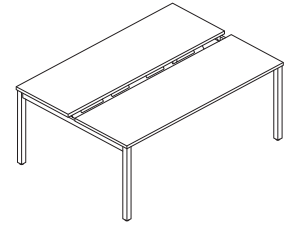
**2-PACK — 72"
72"W x 63"D**

QTY	DESCRIPTION	BUNDLE SKU	LIST PRICE
1	2-PACK BUNDLE Includes all Components Listed Above	HMP3072PK2	\$4,011

SPECIFYING EXAMPLE: Model.Laminate.Edgeband.Paint2.DuplexColor

NOTES: Typicals DO NOT include power in-feeds, screens, storage, or seating.

ADD 1 FABRIC SCREEN: \$727 — SEE PAGE 509

ADD 2 MOBILE PEDESTALS: \$1,170 — SEE PAGE 543

SEE PAGE 512 FOR BUNDLE SKU INFORMATION

QTY	DESCRIPTION	MODEL	LIST PRICE	PRICE EXTENSION
4	Worksurface, Edgeband, No Grommets 30" x 72"	HWR3072PN	\$593	\$2,372
1	Double Depth U-Leg (Box of 2)	HMPEL6028	\$1,249	\$1,249
1	Double Depth Shared U-Leg (Singles)	HMPSL6028	\$514	\$514
2	Support Beams (Box of 2) 72"W	HMPUB272	\$704	\$1,408
2	Shared Trough 72"W	HMPROUGH72	\$479	\$958
1	Power Harness 72"W	HH871272	\$216	\$216
1	End of Run Electrical Kit 72"W	HMPEEK72	\$225	\$225
2	Duplex 1	HH871501	\$42	\$84
2	Duplex 2	HH871502	\$42	\$84
2	Duplex 3	HH871503	\$42	\$84
2	Duplex 4	HH871504	\$42	\$84
TOTAL:			\$7,278	

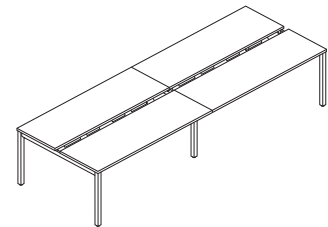
**4-PACK — 72"
144"W x 63"D**

QTY	DESCRIPTION	BUNDLE SKU	LIST PRICE
1	4-PACK BUNDLE Includes all Components Listed Above	HMP3072PK4	\$7,278

SPECIFYING EXAMPLE: Model.Laminate.Edgeband.Paint2.DuplexColor

NOTES: Typicals DO NOT include power in-feeds, screens, storage, or seating.

ADD 2 FABRIC SCREENS: \$1,454 — SEE PAGE 509

ADD 4 MOBILE PEDESTALS: \$2,340 — SEE PAGE 543

SEE PAGE 512 FOR BUNDLE SKU INFORMATION

EMPOWER® 72"W Typicals with 30"D Worksurfaces



Icon Legend on page 19

WORKSTATIONS

QTY	DESCRIPTION	MODEL	LIST PRICE	PRICE EXTENSION
6	Worksurface, Edgeband, No Grommets 30" x 72"	HWR3072PN	\$593	\$3,558
1	Double Depth U-Leg (Box of 2)	HMPEL6028	\$1,249	\$1,249
2	Double Depth Shared U-Leg (Singles)	HMPSL6028	\$514	\$1,028
3	Support Beams (Box of 2) 72"W	HMPUB272	\$704	\$2,112
3	Shared Trough 72"W	HMPROUGH72	\$479	\$1,437
2	Power Harness 72"W	HH871272	\$216	\$432
1	End of Run Electrical Kit 72"W	HMPEEK72	\$225	\$225
3	Duplex 1	HH871501	\$42	\$126
3	Duplex 2	HH871502	\$42	\$126
3	Duplex 3	HH871503	\$42	\$126
3	Duplex 4	HH871504	\$42	\$126
TOTAL:				\$10,545

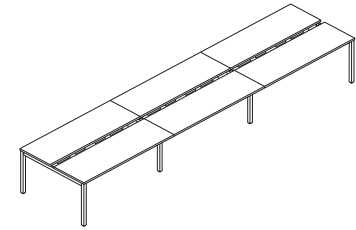

**6-PACK — 72"
216"W x 63"D**

QTY	DESCRIPTION	BUNDLE SKU	LIST PRICE
1	6-PACK BUNDLE Includes all Components Listed Above	HMP3072PK6	\$10,545

SPECIFYING EXAMPLE: Model.Laminate.Edgeband.Paint2.DuplexColor

NOTES: Typicals DO NOT include power in-feeds, screens, storage, or seating.

ADD 3 FABRIC SCREENS: \$2,181 — SEE PAGE 509

ADD 6 MOBILE PEDESTALS: \$3,510 — SEE PAGE 543

SEE PAGE 512 FOR BUNDLE SKU INFORMATION

QTY	DESCRIPTION	MODEL	LIST PRICE	PRICE EXTENSION
8	Worksurface, Edgeband, No Grommets 30" x 72"	HWR3072PN	\$593	\$4,744
1	Double Depth U-Leg (Box of 2)	HMPEL6028	\$1,249	\$1,249
3	Double Depth Shared U-Leg (Singles)	HMPSL6028	\$514	\$1,542
4	Support Beams (Box of 2) 72"W	HMPUB272	\$704	\$2,816
4	Shared Trough 72"W	HMPROUGH72	\$479	\$1,916
3	Power Harness 72"W	HH871272	\$216	\$648
1	End of Run Electrical Kit 72"W	HMPEEK72	\$225	\$225
4	Duplex 1	HH871501	\$42	\$168
4	Duplex 2	HH871502	\$42	\$168
4	Duplex 3	HH871503	\$42	\$168
4	Duplex 4	HH871504	\$42	\$168
TOTAL:				\$13,812

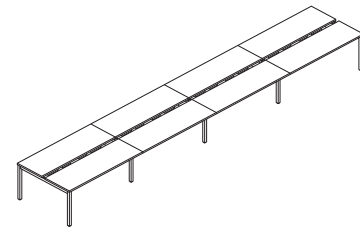

**8-PACK — 72"
288"W x 63"D**

QTY	DESCRIPTION	BUNDLE SKU	LIST PRICE
1	8-PACK BUNDLE Includes all Components Listed Above	HMP3072PK8	\$13,812

SPECIFYING EXAMPLE: Model.Laminate.Edgeband.Paint2.DuplexColor

NOTES: Typicals DO NOT include power in-feeds, screens, storage, or seating.

ADD 4 FABRIC SCREENS: \$2,908 — SEE PAGE 509

ADD 8 MOBILE PEDESTALS: \$4,680 — SEE PAGE 543

SEE PAGE 512 FOR BUNDLE SKU INFORMATION



Icon Legend on page 19

EMPOWER®

60"W Typical with 30"D Worksurfaces

WORKSTATIONS

QTY	DESCRIPTION	MODEL	LIST PRICE	PRICE EXTENSION
2	Worksurface, Edgeband, No Grommets 30" x 60"	HWR3060PN	\$520	\$1,040
1	Double Depth U-Leg (Box of 2)	HMPEL6028	\$1,249	\$1,249
1	Support Beams (Box of 2) 60"W	HMPUB260	\$635	\$635
1	Shared Trough 60"W	HMPROUGH60	\$436	\$436
1	End of Run Electrical Kit 60"W	HMPEEK60	\$225	\$225
1	Duplex 1	HH871501	\$42	\$42
1	Duplex 2	HH871502	\$42	\$42
1	Duplex 3	HH871503	\$42	\$42
1	Duplex 4	HH871504	\$42	\$42
TOTAL:			\$3,753	

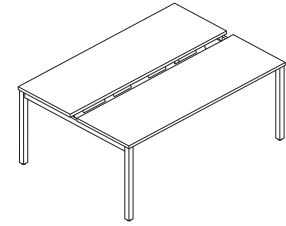

2-PACK — 60"
60"W x 63"D

QTY	DESCRIPTION	BUNDLE SKU	LIST PRICE
1	2-PACK BUNDLE Includes all Components Listed Above	HMP3060PK2	\$3,753

SPECIFYING EXAMPLE: Model.Laminate.Edgeband.Paint2.DuplexColor

NOTES: Typical DO NOT include power in-feeds, screens, storage, or seating.

ADD 1 FABRIC SCREEN: \$656 — SEE PAGE 509

ADD 2 MOBILE PEDESTALS: \$1,170 — SEE PAGE 543

SEE PAGE 512 FOR BUNDLE SKU INFORMATION

QTY	DESCRIPTION	MODEL	LIST PRICE	PRICE EXTENSION
4	Worksurface, Edgeband, No Grommets 30" x 60"	HWR3060PN	\$520	\$2,080
1	Double Depth U-Leg (Box of 2)	HMPEL6028	\$1,249	\$1,249
1	Double Depth Shared U-Leg (Singles)	HMPSL6028	\$514	\$514
2	Support Beams (Box of 2) 60"W	HMPUB260	\$635	\$1,270
2	Shared Trough 60"W	HMPROUGH60	\$436	\$872
1	Power Harness 60"W	HH871260	\$216	\$216
1	End of Run Electrical Kit 60"W	HMPEEK60	\$225	\$225
2	Duplex 1	HH871501	\$42	\$84
2	Duplex 2	HH871502	\$42	\$84
2	Duplex 3	HH871503	\$42	\$84
2	Duplex 4	HH871504	\$42	\$84
TOTAL:			\$6,762	

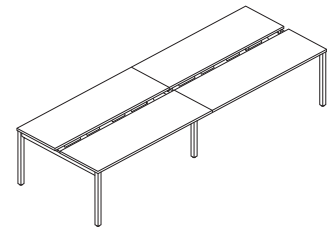

4-PACK — 60"
144"W x 63"D

QTY	DESCRIPTION	BUNDLE SKU	LIST PRICE
1	4-PACK BUNDLE Includes all Components Listed Above	HMP3060PK4	\$6,762

SPECIFYING EXAMPLE: Model.Laminate.Edgeband.Paint2.DuplexColor

NOTES: Typical DO NOT include power in-feeds, screens, storage, or seating.

ADD 2 FABRIC SCREENS: \$1,312 — SEE PAGE 509

ADD 4 MOBILE PEDESTALS: \$2,340 — SEE PAGE 543

SEE PAGE 512 FOR BUNDLE SKU INFORMATION

EMPOWER®

60"W Typicals with 30"D Worksurfaces



Icon Legend on page 19

WORKSTATIONS

QTY	DESCRIPTION	MODEL	LIST PRICE	PRICE EXTENSION
6	Worksurface, Edgeband, No Grommets 30" x 60"	HWR3060PN	\$520	\$3,120
1	Double Depth U-Leg (Box of 2)	HMPDL6028	\$1,249	\$1,249
2	Double Depth Shared U-Leg (Singles)	HMPDL6028	\$514	\$1,028
3	Support Beams (Box of 2) 60"W	HMPUB260	\$635	\$1,905
3	Shared Trough 60"W	HMPDROUGH60	\$436	\$1,308
2	Power Harness 60"W	HH871260	\$216	\$432
1	End of Run Electrical Kit 60"W	HMPEEK60	\$225	\$225
3	Duplex 1	HH871501	\$42	\$126
3	Duplex 2	HH871502	\$42	\$126
3	Duplex 3	HH871503	\$42	\$126
3	Duplex 4	HH871504	\$42	\$126
TOTAL:				\$9,771

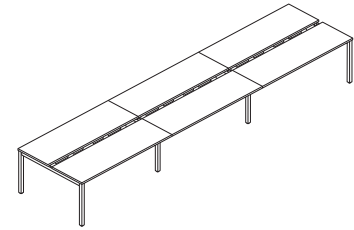

6-PACK — 60"
180"W x 63"D

QTY	DESCRIPTION	BUNDLE SKU	LIST PRICE
1	6-PACK BUNDLE Includes all Components Listed Above	HMP3060PK6	\$9,771

SPECIFYING EXAMPLE: Model.Laminate.Edgeband.Paint2.DuplexColor

NOTES: Typicals DO NOT include power in-feeds, screens, storage, or seating.

ADD 3 FABRIC SCREENS: \$1,968 — SEE PAGE 509

ADD 6 MOBILE PEDESTALS: \$3,510 — SEE PAGE 543

SEE PAGE 512 FOR BUNDLE SKU INFORMATION

QTY	DESCRIPTION	MODEL	LIST PRICE	PRICE EXTENSION
8	Worksurface, Edgeband, No Grommets 30" x 60"	HWR3060PN	\$520	\$4,160
1	Double Depth U-Leg (Box of 2)	HMPDL6028	\$1,249	\$1,249
3	Double Depth Shared U-Leg (Singles)	HMPDL6028	\$514	\$1,542
4	Support Beams (Box of 2) 60"W	HMPUB260	\$635	\$2,540
4	Shared Trough 60"W	HMPDROUGH60	\$436	\$1,744
3	Power Harness 60"W	HH871260	\$216	\$648
1	End of Run Electrical Kit 60"W	HMPEEK60	\$225	\$225
4	Duplex 1	HH871501	\$42	\$168
4	Duplex 2	HH871502	\$42	\$168
4	Duplex 3	HH871503	\$42	\$168
4	Duplex 4	HH871504	\$42	\$168
TOTAL:				\$12,780

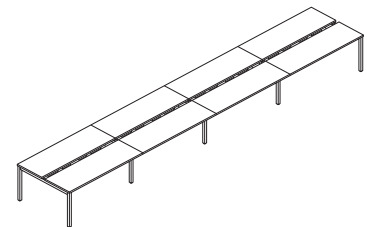

8-PACK — 60"
240"W x 63"D

QTY	DESCRIPTION	BUNDLE SKU	LIST PRICE
1	8-PACK BUNDLE Includes all Components Listed Above	HMP3060PK8	\$12,780

SPECIFYING EXAMPLE: Model.Laminate.Edgeband.Paint2.DuplexColor

NOTES: Typicals DO NOT include power in-feeds, screens, storage, or seating.

ADD 4 FABRIC SCREENS: \$2,624 — SEE PAGE 509

ADD 8 MOBILE PEDESTALS: \$4,680 — SEE PAGE 543

SEE PAGE 512 FOR BUNDLE SKU INFORMATION



Icon Legend on page 19

EMPOWER[®] 120° Workstation Typicals

QTY	DESCRIPTION	MODEL	LIST PRICE	PRICE EXTENSION
3	120 Degree Corner Worksurfaces with Curved User Edge, No Grommets 48"W x 30"D	HBWCT4830PN	\$1,164	\$3,492
3	Double Depth U-Leg (Single Leg)	HMP120EL4828	\$569	\$1,707
3	Single Post Leg 28½"H	HMP120POST	\$297	\$891
3	Support Beams (Box of 2) 48"W	HMP120UB248	\$571	\$1,713
3	Double-Sided Trough 48"W	HMP120TROUGH48	\$396	\$1,188
TOTAL:				\$8,991

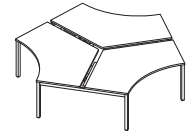

3-PACK – 120°

NOTES: Typicals DO NOT include power in-feeds, screens, storage, or seating.

ADD 3 FABRIC SCREENS: \$1,662 — SEE PAGE 509

ADD 3 MOBILE PEDESTALS: \$1,755 — SEE PAGE 543

QTY	DESCRIPTION	MODEL	LIST PRICE	PRICE EXTENSION
6	120 Degree Corner Worksurfaces with Curved User Edge, No Grommets 48"W x 30"D	HBWCT4830PN	\$1,164	\$6,984
4	Double Depth U-Leg (Single Leg)	HMP120EL6028	\$626	\$2,504
6	Single Post Leg 28½"H	HMP120POST	\$297	\$1,782
6	Support Beams (Box of 2) 48"W	HMP120UB248	\$571	\$3,426
6	Double-Sided Trough 48"W	HMP120TROUGH48	\$396	\$2,376
2	Double Depth Shared U-Leg (Singles)	HMPSL6028	\$514	\$1,028
2	Worksurface with Edgeband 48"W x 30"D	HWR3048PN	\$436	\$872
1	Support Beams (Box of 2) 48"W	HMPUB248	\$571	\$571
1	Double-Sided Trough 48"W	HMP120TROUGH48	\$396	\$396
TOTAL:				\$19,939

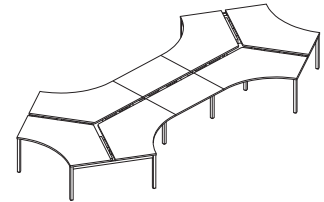

DOG BONE – 120°

NOTES: Typicals DO NOT include power in-feeds, screens, storage, or seating.

ADD 7 FABRIC SCREENS: \$3,878 — SEE PAGE 509

ADD 6 MOBILE PEDESTALS: \$3,510 — SEE PAGE 543

EMPOWER[®] 120° Workstation Typical



Icon Legend on page 19

WORKSTATIONS

QTY	DESCRIPTION	MODEL	LIST PRICE	PRICE EXTENSION
9	120 Degree Corner Worksurfaces with Curved User Edge, No Grommets 48"W x 30"D	HBWCT4830PN	\$1,164	\$10,476
5	Double Depth U-Leg (Single Leg)	HMP120EL4828	\$569	\$2,845
9	Single Post Leg 28½"H	HMP120POST	\$297	\$2,673
9	Support Beams (Box of 2) 48"W	HMP120UB248	\$571	\$5,139
9	Double-Sided Trough 48"W	HMP120TROUGH48	\$396	\$3,564
2	Double Depth Shared U-Leg (Singles)	HMPSL4828	\$468	\$936
TOTAL:				\$25,633

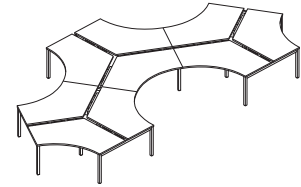

MULTIPLE PODS — 120°

NOTES: Typical DO NOT include power in-feeds, screens, storage, or seating.

ADD 9 FABRIC SCREENS: \$4,986 — SEE PAGE 509

ADD 9 MOBILE PEDESTALS: \$5,265 — SEE PAGE 543



Icon Legend on page 19

72"W Height Adjustable Typicals with 24"D Worksurfaces

QTY	DESCRIPTION	MODEL	LIST PRICE	PRICE EXTENSION
2	Worksurface, Edgeband, No Grommets 24" x 72"	HHAW2472PN	\$552	\$1,104
1	Height Adjustable Base	HMPHA2S4C	\$2,286	\$2,286
1	Height Adjustable Shared Trough 72"W	HMPHATROUGH72	\$479	\$479
2	Single-Sided Trough Lid	HMPHASLID72	\$138	\$276
1	End of Run Electrical Kit 72"W	HMPEEK72	\$225	\$225
1	Duplex 1	HH871501	\$42	\$42
1	Duplex 2	HH871502	\$42	\$42
1	Duplex 3	HH871503	\$42	\$42
1	Duplex 4	HH871504	\$42	\$42
TOTAL:				\$4,538

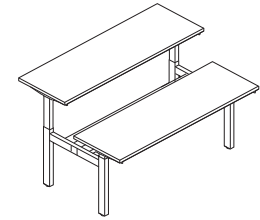
**2-PACK — 72"
72"W x 51"D**

QTY	DESCRIPTION	BUNDLE SKU	LIST PRICE
1	2-PACK BUNDLE Includes all Components Listed Above	HMPHA2472PK2	\$4,538

SPECIFYING EXAMPLE: Model.Laminate.Edgeband.BasePaint.TroughPaint.DuplexColor

NOTES: Typicals DO NOT include power in-feeds, screens, storage, or seating.

ADD 2 FABRIC SCREENS: \$1,454— SEE PAGE 509**ADD 2 MOBILE PEDESTALS: \$1,170— SEE PAGE 543****SEE PAGE 513 FOR BUNDLE SKU INFORMATION**

QTY	DESCRIPTION	MODEL	LIST PRICE	PRICE EXTENSION
4	Worksurface, Edgeband, No Grommets 24" x 72"	HHAW2472PN	\$552	\$2,208
2	Height Adjustable Base	HMPHA2S4C	\$2,286	\$4,572
2	Height Adjustable Shared Trough 72"W	HMPHATROUGH72	\$479	\$958
4	Single-Sided Trough Lid	HMPHASLID72	\$138	\$552
1	Power Harness 72"W	HH871272	\$216	\$216
1	End of Run Electrical Kit 72"W	HMPEEK72	\$225	\$225
2	Duplex 1	HH871501	\$42	\$84
2	Duplex 2	HH871502	\$42	\$84
2	Duplex 3	HH871503	\$42	\$84
2	Duplex 4	HH871504	\$42	\$84
TOTAL:				\$9,067

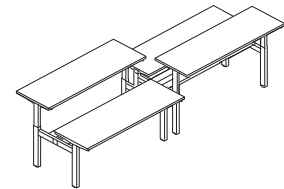
**4-PACK — 72"
144"W x 51"D**

QTY	DESCRIPTION	BUNDLE SKU	LIST PRICE
1	4-PACK BUNDLE Includes all Components Listed Above	HMPHA2472PK4	\$9,067

SPECIFYING EXAMPLE: Model.Laminate.Edgeband.BasePaint.TroughPaint.DuplexColor

NOTES: Typicals DO NOT include power in-feeds, screens, storage, or seating.

ADD 4 FABRIC SCREENS: \$2,908— SEE PAGE 509**ADD 4 MOBILE PEDESTALS: \$2,340— SEE PAGE 543****SEE PAGE 513 FOR BUNDLE SKU INFORMATION**



QTY	DESCRIPTION	MODEL	LIST PRICE	PRICE EXTENSION
6	Worksurface, Edgeband, No Grommets 24" x 72"	HHAW2472PN	\$552	\$3,312
3	Height Adjustable Base	HMPHA2S4C	\$2,286	\$6,858
3	Height Adjustable Shared Trough 72"W	HMPHATROUGH72	\$479	\$1,437
6	Single-Sided Trough Lid	HMPHASLID72	\$138	\$828
2	Power Harness 72"W	HH871272	\$216	\$432
1	End of Run Electrical Kit 72"W	HMPEEK72	\$225	\$225
3	Duplex 1	HH871501	\$42	\$126
3	Duplex 2	HH871502	\$42	\$126
3	Duplex 3	HH871503	\$42	\$126
3	Duplex 4	HH871504	\$42	\$126
TOTAL:				\$13,596

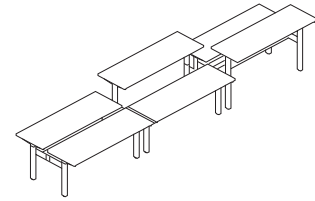

6-PACK — 72"
216"W x 51"D

QTY	DESCRIPTION	BUNDLE SKU	LIST PRICE
1	6-PACK BUNDLE Includes all Components Listed Above	HMPHA2472PK6	\$13,596

SPECIFYING EXAMPLE: Model.Laminate.Edgeband.BasePaint.TroughPaint.DuplexColor

NOTES: Typicals DO NOT include power in-feeds, screens, storage, or seating.

ADD 6 FABRIC SCREENS: \$4,362 — SEE PAGE 509

ADD 6 MOBILE PEDESTALS: \$3,510 — SEE PAGE 543

SEE PAGE 513 FOR BUNDLE SKU INFORMATION

QTY	DESCRIPTION	MODEL	LIST PRICE	PRICE EXTENSION
8	Worksurface, Edgeband, No Grommets 24" x 72"	HHAW2472PN	\$552	\$4,416
4	Height Adjustable Base	HMPHA2S4C	\$2,286	\$9,144
4	Height Adjustable Shared Trough 72"W	HMPHATROUGH72	\$479	\$1,916
8	Single-Sided Trough Lid	HMPHASLID72	\$138	\$1,104
3	Power Harness 72"W	HH871272	\$216	\$648
1	End of Run Electrical Kit 72"W	HMPEEK72	\$225	\$225
4	Duplex 1	HH871501	\$42	\$168
4	Duplex 2	HH871502	\$42	\$168
4	Duplex 3	HH871503	\$42	\$168
4	Duplex 4	HH871504	\$42	\$168
TOTAL:				\$18,125

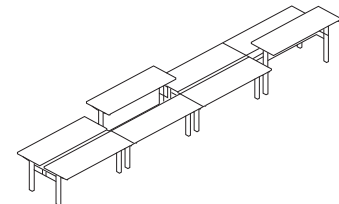

8-PACK — 72"
288"W x 51"D

QTY	DESCRIPTION	BUNDLE SKU	LIST PRICE
1	8-PACK BUNDLE Includes all Components Listed Above	HMPHA2472PK8	\$18,125

SPECIFYING EXAMPLE: Model.Laminate.Edgeband.BasePaint.TroughPaint.DuplexColor

NOTES: Typicals DO NOT include power in-feeds, screens, storage, or seating.

ADD 8 FABRIC SCREENS: \$5,816 — SEE PAGE 509

ADD 8 MOBILE PEDESTALS: \$4,680 — SEE PAGE 543

SEE PAGE 513 FOR BUNDLE SKU INFORMATION



Icon Legend on page 19

QTY	DESCRIPTION	MODEL	LIST PRICE	PRICE EXTENSION
2	Worksurface, Edgeband, No Grommets 24" x 60"	HHAW2460PN	\$499	\$998
1	Height Adjustable Base	HMPHA2S4C	\$2,286	\$2,286
1	Height Adjustable Shared Trough 60"W	HMPHATROUGH60	\$436	\$436
2	Single-Sided Trough Lid	HMPHASLID60	\$126	\$252
1	End of Run Electrical Kit 60"W	HMPEEK60	\$225	\$225
1	Duplex 1	HH871501	\$42	\$42
1	Duplex 2	HH871502	\$42	\$42
1	Duplex 3	HH871503	\$42	\$42
1	Duplex 4	HH871504	\$42	\$42
TOTAL:				\$4,365

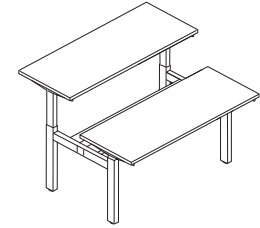
**2-PACK — 60"
60"W x 51"D**

QTY	DESCRIPTION	BUNDLE SKU	LIST PRICE
1	2-PACK BUNDLE Includes all Components Listed Above	HMPHA2460PK2	\$4,365

SPECIFYING EXAMPLE: Model.Laminate.Edgeband.BasePaint.TroughPaint.DuplexColor

NOTES: Typicals DO NOT include power in-feeds, screens, storage, or seating.

ADD 2 FABRIC SCREENS: \$1,312 — SEE PAGE 509**ADD 2 MOBILE PEDESTALS: \$1,170 — SEE PAGE 543****SEE PAGE 513 FOR BUNDLE SKU INFORMATION**

QTY	DESCRIPTION	MODEL	LIST PRICE	PRICE EXTENSION
4	Worksurface, Edgeband, No Grommets 24" x 60"	HHAW2460PN	\$499	\$1,996
2	Height Adjustable Base	HMPHA2S4C	\$2,286	\$4,572
2	Height Adjustable Shared Trough 60"W	HMPHATROUGH60	\$436	\$872
4	Single-Sided Trough Lid	HMPHASLID60	\$126	\$504
1	Power Harness 60"W	HH871260	\$216	\$216
1	End of Run Electrical Kit 60"W	HMPEEK60	\$225	\$225
2	Duplex 1	HH871501	\$42	\$84
2	Duplex 2	HH871502	\$42	\$84
2	Duplex 3	HH871503	\$42	\$84
2	Duplex 4	HH871504	\$42	\$84
TOTAL:				\$8,721

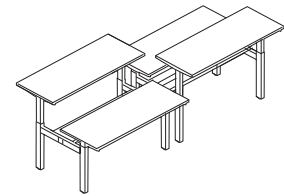
**4-PACK — 60"
120"W x 51"D**

QTY	DESCRIPTION	BUNDLE SKU	LIST PRICE
1	4-PACK BUNDLE Includes all Components Listed Above	HMPHA2460PK4	\$8,721

SPECIFYING EXAMPLE: Model.Laminate.Edgeband.BasePaint.TroughPaint.DuplexColor

NOTES: Typicals DO NOT include power in-feeds, screens, storage, or seating.

ADD 4 FABRIC SCREENS: \$2,624 — SEE PAGE 509**ADD 4 MOBILE PEDESTALS: \$2,340 — SEE PAGE 543****SEE PAGE 513 FOR BUNDLE SKU INFORMATION**



QTY	DESCRIPTION	MODEL	LIST PRICE	PRICE EXTENSION
6	Worksurface, Edgeband, No Grommets 24" x 60"	HHAW2460PN	\$499	\$2,994
3	Height Adjustable Base	HMPHA2S4C	\$2,286	\$6,858
3	Height Adjustable Shared Trough 60"W	HMPHATROUGH60	\$436	\$1,308
6	Single-Sided Trough Lid	HMPHASLID60	\$126	\$756
2	Power Harness 60"W	HH871260	\$216	\$432
1	End of Run Electrical Kit 60"W	HMPEEK60	\$225	\$225
3	Duplex 1	HH871501	\$42	\$126
3	Duplex 2	HH871502	\$42	\$126
3	Duplex 3	HH871503	\$42	\$126
3	Duplex 4	HH871504	\$42	\$126
TOTAL:				\$13,077

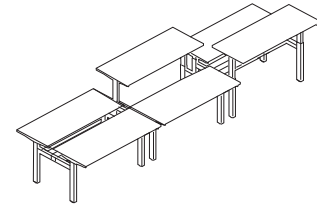

6-PACK — 60"
180"W x 51"D

QTY	DESCRIPTION	BUNDLE SKU	LIST PRICE
1	6-PACK BUNDLE Includes all Components Listed Above	HMPHA2460PK6	\$13,077

SPECIFYING EXAMPLE: Model.Laminate.Edgeband.BasePaint.TroughPaint.DuplexColor

NOTES: Typicals DO NOT include power in-feeds, screens, storage, or seating.

ADD 6 FABRIC SCREENS: \$3,936 — SEE PAGE 509

ADD 6 MOBILE PEDESTALS: \$3,510 — SEE PAGE 543

SEE PAGE 513 FOR BUNDLE SKU INFORMATION

QTY	DESCRIPTION	MODEL	LIST PRICE	PRICE EXTENSION
8	Worksurface, Edgeband, No Grommets 24" x 60"	HHAW2460PN	\$499	\$3,992
4	Height Adjustable Base	HMPHA2S4C	\$2,286	\$9,144
4	Height Adjustable Shared Trough 60"W	HMPHATROUGH60	\$436	\$1,744
8	Single-Sided Trough Lid	HMPHASLID60	\$126	\$1,008
3	Power Harness 60"W	HH871260	\$216	\$648
1	End of Run Electrical Kit 60"W	HMPEEK60	\$225	\$225
4	Duplex 1	HH871501	\$42	\$168
4	Duplex 2	HH871502	\$42	\$168
4	Duplex 3	HH871503	\$42	\$168
4	Duplex 4	HH871504	\$42	\$168
TOTAL:				\$17,433

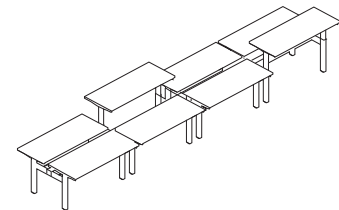

8-PACK — 60"
240"W x 51"D

QTY	DESCRIPTION	BUNDLE SKU	LIST PRICE
1	8-PACK BUNDLE Includes all Components Listed Above	HMPHA2460PK8	\$17,433

SPECIFYING EXAMPLE: Model.Laminate.Edgeband.BasePaint.TroughPaint.DuplexColor

NOTES: Typicals DO NOT include power in-feeds, screens, storage, or seating.

ADD 8 FABRIC SCREENS: \$5,248 — SEE PAGE 509

ADD 8 MOBILE PEDESTALS: \$4,680 — SEE PAGE 543

SEE PAGE 513 FOR BUNDLE SKU INFORMATION



Icon Legend on page 19

72"W Height Adjustable Typicals with 30"D Worksurfaces

QTY	DESCRIPTION	MODEL	LIST PRICE	PRICE EXTENSION
2	Worksurface, Edgeband, No Grommets 30" x 72"	HHAW3072PN	\$616	\$1,232
1	Height Adjustable Base	HMPHA2S4C	\$2,286	\$2,286
1	Height Adjustable Shared Trough 72"W	HMPHATROUGH72	\$479	\$479
2	Single-Sided Trough Lid	HMPHASLID72	\$138	\$276
1	End of Run Electrical Kit 72"W	HMPEEK72	\$225	\$225
1	Duplex 1	HH871501	\$42	\$42
1	Duplex 2	HH871502	\$42	\$42
1	Duplex 3	HH871503	\$42	\$42
1	Duplex 4	HH871504	\$42	\$42
TOTAL:				\$4,666

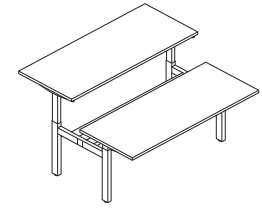

**2-PACK — 72"
72"W x 63"D**

QTY	DESCRIPTION	BUNDLE SKU	LIST PRICE
1	2-PACK BUNDLE Includes all Components Listed Above	HMPHA3072PK2	\$4,666

SPECIFYING EXAMPLE: Model.Laminate.Edgeband.BasePaint.TroughPaint.DuplexColor

NOTES: Typicals DO NOT include power in-feeds, screens, storage, or seating.

ADD 2 FABRIC SCREENS: \$1,454 — SEE PAGE 509

ADD 2 MOBILE PEDESTALS: \$1,170 — SEE PAGE 543

SEE PAGE 513 FOR BUNDLE SKU INFORMATION

QTY	DESCRIPTION	MODEL	LIST PRICE	PRICE EXTENSION
4	Worksurface, Edgeband, No Grommets 30" x 72"	HHAW3072PN	\$616	\$2,464
2	Height Adjustable Base	HMPHA2S4C	\$2,286	\$4,572
2	Height Adjustable Shared Trough 72"W	HMPHATROUGH72	\$479	\$958
4	Single-Sided Trough Lid	HMPHASLID72	\$138	\$552
1	Power Harness 72"W	HH871272	\$216	\$216
1	End of Run Electrical Kit 72"W	HMPEEK72	\$225	\$225
2	Duplex 1	HH871501	\$42	\$84
2	Duplex 2	HH871502	\$42	\$84
2	Duplex 3	HH871503	\$42	\$84
2	Duplex 4	HH871504	\$42	\$84
TOTAL:				\$9,323

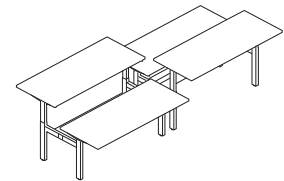

**4-PACK — 72"
144"W x 63"D**

QTY	DESCRIPTION	BUNDLE SKU	LIST PRICE
1	4-PACK BUNDLE Includes all Components Listed Above	HMPHA3072PK4	\$9,323

SPECIFYING EXAMPLE: Model.Laminate.Edgeband.BasePaint.TroughPaint.DuplexColor

NOTES: Typicals DO NOT include power in-feeds, screens, storage, or seating.

ADD 4 FABRIC SCREENS: \$2,908 — SEE PAGE 509

ADD 4 MOBILE PEDESTALS: \$2,340 — SEE PAGE 543

SEE PAGE 513 FOR BUNDLE SKU INFORMATION



QTY	DESCRIPTION	MODEL	LIST PRICE	PRICE EXTENSION
6	Worksurface, Edgeband, No Grommets 30" x 72"	HHAW3072PN	\$616	\$3,696
3	Height Adjustable Base	HMPHA2S4C	\$2,286	\$6,858
3	Height Adjustable Shared Trough 72"W	HMPHATROUGH72	\$479	\$1,437
6	Single-Sided Trough Lid	HMPHASLID72	\$138	\$828
2	Power Harness 72"W	HH871272	\$216	\$432
1	End of Run Electrical Kit 72"W	HMPEEK72	\$225	\$225
3	Duplex 1	HH871501	\$42	\$126
3	Duplex 2	HH871502	\$42	\$126
3	Duplex 3	HH871503	\$42	\$126
3	Duplex 4	HH871504	\$42	\$126
TOTAL:				\$13,980

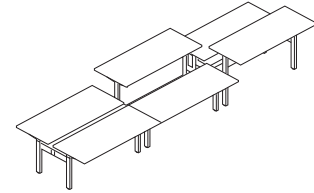

**6-PACK — 72"
216"W x 63"D**

QTY	DESCRIPTION	BUNDLE SKU	LIST PRICE
1	6-PACK BUNDLE Includes all Components Listed Above	HMPHA3072PK6	\$13,980

SPECIFYING EXAMPLE: Model.Laminate.Edgeband.BasePaint.TroughPaint.DuplexColor

NOTES: Typicals DO NOT include power in-feeds, screens, storage, or seating.

ADD 6 FABRIC SCREENS: \$4,362 — SEE PAGE 509

ADD 6 MOBILE PEDESTALS: \$3,510 — SEE PAGE 543

SEE PAGE 513 FOR BUNDLE SKU INFORMATION

QTY	DESCRIPTION	MODEL	LIST PRICE	PRICE EXTENSION
8	Worksurface, Edgeband, No Grommets 30" x 72"	HHAW3072PN	\$616	\$4,928
4	Height Adjustable Base	HMPHA2S4C	\$2,286	\$9,144
4	Height Adjustable Shared Trough 72"W	HMPHATROUGH72	\$479	\$1,916
8	Single-Sided Trough Lid	HMPHASLID72	\$138	\$1,104
3	Power Harness 72"W	HH871272	\$216	\$648
1	End of Run Electrical Kit 72"W	HMPEEK72	\$225	\$225
4	Duplex 1	HH871501	\$42	\$168
4	Duplex 2	HH871502	\$42	\$168
4	Duplex 3	HH871503	\$42	\$168
4	Duplex 4	HH871504	\$42	\$168
TOTAL:				\$18,637

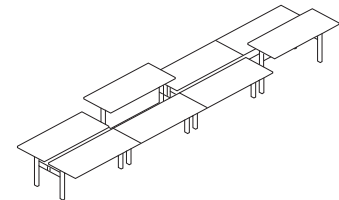

**8-PACK — 72"
288"W x 63"D**

QTY	DESCRIPTION	BUNDLE SKU	LIST PRICE
1	8-PACK BUNDLE Includes all Components Listed Above	HMPHA3072PK8	\$18,637

SPECIFYING EXAMPLE: Model.Laminate.Edgeband.BasePaint.TroughPaint.DuplexColor

NOTES: Typicals DO NOT include power in-feeds, screens, storage, or seating.

ADD 8 FABRIC SCREENS: \$5,816 — SEE PAGE 509

ADD 8 MOBILE PEDESTALS: \$4,680 — SEE PAGE 543

SEE PAGE 513 FOR BUNDLE SKU INFORMATION



Icon Legend on page 19

QTY	DESCRIPTION	MODEL	LIST PRICE	PRICE EXTENSION
2	Worksurface, Edgeband, No Grommets 30'' x 60''	HHAW3060PN	\$544	\$1,088
1	Height Adjustable Base	HMPHA2S4C	\$2,286	\$2,286
1	Height Adjustable Shared Trough 60''W	HMPHATROUGH60	\$436	\$436
2	Single-Sided Trough Lid	HMPHASLID60	\$126	\$252
1	End of Run Electrical Kit 60''W	HMPEEK60	\$225	\$225
1	Duplex 1	HH871501	\$42	\$42
1	Duplex 2	HH871502	\$42	\$42
1	Duplex 3	HH871503	\$42	\$42
1	Duplex 4	HH871504	\$42	\$42
TOTAL:				\$4,455

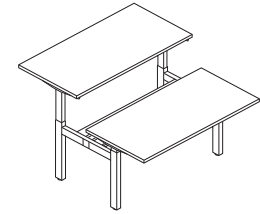
**2-PACK – 60''
60''W x 63''D**

QTY	DESCRIPTION	BUNDLE SKU	LIST PRICE
1	2-PACK BUNDLE Includes all Components Listed Above	HMPHA3060PK2	\$4,455

SPECIFYING EXAMPLE: Model.Laminate.Edgeband.BasePaint.TroughPaint.DuplexColor

NOTES: Typicals DO NOT include power in-feeds, screens, storage, or seating.

ADD 2 FABRIC SCREENS: \$1,312 — SEE PAGE 509**ADD 2 MOBILE PEDESTALS: \$1,170 — SEE PAGE 543****SEE PAGE 513 FOR BUNDLE SKU INFORMATION**

QTY	DESCRIPTION	MODEL	LIST PRICE	PRICE EXTENSION
4	Worksurface, Edgeband, No Grommets 30'' x 60''	HHAW3060PN	\$544	\$2,176
2	Height Adjustable Base	HMPHA2S4C	\$2,286	\$4,572
2	Height Adjustable Shared Trough 60''W	HMPHATROUGH60	\$436	\$872
4	Single-Sided Trough Lid	HMPHASLID60	\$126	\$504
1	Power Harness 60''W	HH871260	\$216	\$216
1	End of Run Electrical Kit 60''W	HMPEEK60	\$225	\$225
2	Duplex 1	HH871501	\$42	\$84
2	Duplex 2	HH871502	\$42	\$84
2	Duplex 3	HH871503	\$42	\$84
2	Duplex 4	HH871504	\$42	\$84
TOTAL:				\$8,901

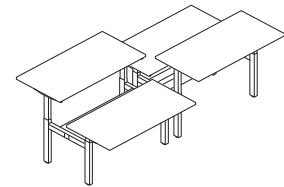
**4-PACK – 60''
120''W x 63''D**

QTY	DESCRIPTION	BUNDLE SKU	LIST PRICE
1	4-PACK BUNDLE Includes all Components Listed Above	HMPHA3060PK4	\$8,901

SPECIFYING EXAMPLE: Model.Laminate.Edgeband.BasePaint.TroughPaint.DuplexColor

NOTES: Typicals DO NOT include power in-feeds, screens, storage, or seating.

ADD 4 FABRIC SCREENS: \$2,624 — SEE PAGE 509**ADD 4 MOBILE PEDESTALS: \$2,340 — SEE PAGE 543****SEE PAGE 513 FOR BUNDLE SKU INFORMATION**



QTY	DESCRIPTION	MODEL	LIST PRICE	PRICE EXTENSION
6	Worksurface, Edgeband, No Grommets 30" x 60"	HHAW3060PN	\$544	\$3,264
3	Height Adjustable Base	HMPHA2S4C	\$2,286	\$6,858
3	Height Adjustable Shared Trough 60"W	HMPHATROUGH60	\$436	\$1,308
6	Single-Sided Trough Lid	HMPHASLID60	\$126	\$756
2	Power Harness 60"W	HH871260	\$216	\$432
1	End of Run Electrical Kit 60"W	HMPEEK60	\$225	\$225
3	Duplex 1	HH871501	\$42	\$126
3	Duplex 2	HH871502	\$42	\$126
3	Duplex 3	HH871503	\$42	\$126
3	Duplex 4	HH871504	\$42	\$126
TOTAL:				\$13,347

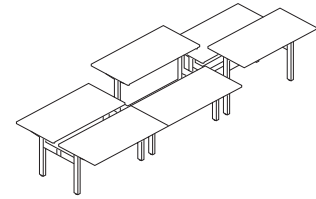

6-PACK — 60"
180" W x 63" D

QTY	DESCRIPTION	BUNDLE SKU	LIST PRICE
1	6-PACK BUNDLE Includes all Components Listed Above	HMPHA3060PK6	\$13,347

SPECIFYING EXAMPLE: Model.Laminate.Edgeband.BasePaint.TroughPaint.DuplexColor

NOTES: Typicals DO NOT include power in-feeds, screens, storage, or seating.

ADD 6 FABRIC SCREENS: \$3,936 — SEE PAGE 509

ADD 6 MOBILE PEDESTALS: \$3,510 — SEE PAGE 543

SEE PAGE 513 FOR BUNDLE SKU INFORMATION

QTY	DESCRIPTION	MODEL	LIST PRICE	PRICE EXTENSION
8	Worksurface, Edgeband, No Grommets 30" x 60"	HHAW3060PN	\$544	\$4,352
4	Height Adjustable Base	HMPHA2S4C	\$2,286	\$9,144
4	Height Adjustable Shared Trough 60"W	HMPHATROUGH60	\$436	\$1,744
8	Single-Sided Trough Lid	HMPHASLID60	\$126	\$1,008
3	Power Harness 60"W	HH871260	\$216	\$648
1	End of Run Electrical Kit 60"W	HMPEEK60	\$225	\$225
4	Duplex 1	HH871501	\$42	\$168
4	Duplex 2	HH871502	\$42	\$168
4	Duplex 3	HH871503	\$42	\$168
4	Duplex 4	HH871504	\$42	\$168
TOTAL:				\$17,793

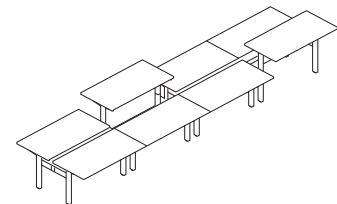

8-PACK — 60"
240" W x 63" D

QTY	DESCRIPTION	BUNDLE SKU	LIST PRICE
1	8-PACK BUNDLE Includes all Components Listed Above	HMPHA3060PK8	\$17,793

SPECIFYING EXAMPLE: Model.Laminate.Edgeband.BasePaint.TroughPaint.DuplexColor

NOTES: Typicals DO NOT include power in-feeds, screens, storage, or seating.

ADD 8 FABRIC SCREENS: \$5,248 — SEE PAGE 509

ADD 8 MOBILE PEDESTALS: \$4,680 — SEE PAGE 543

SEE PAGE 513 FOR BUNDLE SKU INFORMATION

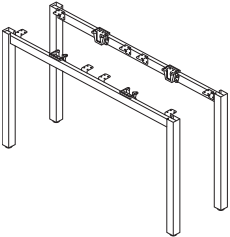
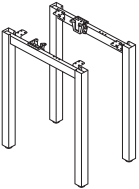
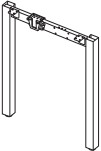

EMPOWER® Legs for Linear Applications

	DESCRIPTION	MODEL	SHIP WEIGHT	CUBE	LIST PRICE BY PAINT GRADE		
					P1	P2	P3
	Double Depth U-Leg (Box of 2) 50½"D for use with 24"D Worksurfaces 62½"D for use with 30"D Worksurfaces NOTES: Ships as a box of 2 legs.	HMPPEL4828 ☉ HMPPEL6028	32.4 34.8	14.9 18.5	\$1136 \$1249	\$1140 \$1253	\$1170 \$1286
	Double Depth Shared U-Leg (Singles) 30"D for use with 24"D Worksurfaces 42"D for use with 30"D Worksurfaces	HMPPSL4828 ☉ HMPPSL6028	21.1 22.5	4.9 6.4	\$468 \$514	\$472 \$518	\$482 \$529
	Single Depth U-Leg (Box of 2) 24"D for use with 24"D Worksurfaces 30"D for use with 30"D Worksurfaces	HMPPEL2428 HMPPEL3028	23.7 24.9	7.6 9.4	\$567 \$626	\$571 \$630	\$595 \$657
	Single Depth Shared U-Leg (Singles) 18"D for use with 24"D Worksurfaces 24"D for use with 30"D Worksurfaces	HMPPSL2428 HMPPSL3028	14.8 15.6	3.2 4.0	\$345 \$380	\$349 \$384	\$362 \$399
	Single Depth Return U-Leg (Singles) Left Right NOTES: Return U-Legs ship with two flat brackets.	HMPPREL2428 HMPPREL2428	23.7 23.7	4.0 4.0	\$345 \$345	\$349 \$349	\$362 \$362

HOW TO SPECIFY

Select Model Number H M P E L 4 8 2 8	Select Paint Color See page 478 T 1
---	--

EMPOWER[®] Legs for 120° Applications

GSA SIN 33721



Icon Legend on page 19

WORKSTATIONS

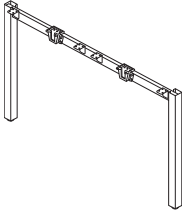

DESCRIPTION	MODEL	SHIP WEIGHT	CUBE	LIST PRICE BY PAINT GRADE		
				P1	P2	P3
Double Depth U-Leg (Single Leg for 120° Applications) 50½"D for use with 24"D Worksurfaces	HMP120EL4828	19	7.9	\$569	\$573	\$597
60½"D for use with 30"D Worksurfaces	HMP120EL6028	20	9.6	\$626	\$630	\$657

NOTES: Ships as single leg for 120 degree applications.

! 120 degree surfaces must be used in back-to-back applications — cannot be used freestanding.

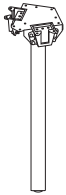

DESCRIPTION	MODEL	SHIP WEIGHT	CUBE	P1	P2	P3
Post Leg for 120° Applications (Singles) 28½"H	HMP120POST	10	1.4	\$297	\$301	\$312

NOTES: One post leg needed per 120 degree worksurface. Post leg ships with attachment brackets needed to connect support beams and worksurfaces.

! 120 degree surfaces must be used in back-to-back applications — cannot be used freestanding.

Worksurface Width	Electrical Model	Quantity
36"	HH871124	1
36"	HH871148	2
42"	HH871124	1
42"	HH871160	2
48"	HH871124	1
48"	HH871172	2

HOW TO SPECIFY

<p>Select Model Number</p> <p>HMP120EL4828</p>	<p>Select Paint Color</p> <p>See page 478</p> <p>T1</p>
---	--

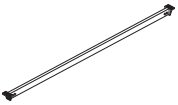
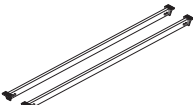
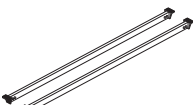

EMPOWER[®] Support Beams

	DESCRIPTION	MODEL	SHIP WEIGHT	CUBE	LIST PRICE
	Support Beams (Box of 1)				
	48"W	HMPUB148	7.0	0.5	\$286
	60"W	HMPUB160	8.3	0.7	\$319
	72"W	HMPUB172	9.6	0.9	\$353
	NOTES: One support beam per worksurface is needed. ⓘ Available in graphite finish only. No specification needed.				
	Support Beams (Box of 2)				
	48"W	HMPUB248	13.3	0.5	\$571
	60"W	HMPUB260 ⓘ	15.8	0.7	\$635
	72"W	HMPUB272	18.2	0.9	\$704
	NOTES: For use with double-sided stations. One support beam per worksurface is needed. ⓘ Available in graphite finish only. No specification needed.				
	Support Beams for 120° Applications (Box of 2)				
	36"W	HMP120UB236	7.8	0.9	\$452
	42"W	HMP120UB242	9.5	0.9	\$509
	48"W	HMP120UB248	11.0	0.9	\$571
	NOTES: Two support beams per 120 degree worksurface are needed. ⓘ Available in graphite finish only. No specification needed.				

NOTES:

- For use with stationary, single-sided stations. 36"W returns will use the 48"W Support Beam and 48"W returns will use the 60"W Support Beam.

HOW TO SPECIFY

Select Model Number

H M P 1 2 0 U B 2 3 6

EMPOWER® Wire Troughs

GSA SIN 33721



Icon Legend on page 19

WORKSTATIONS

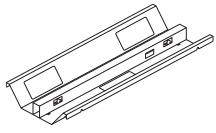

DESCRIPTION

Trough — Double-Sided

48"W
60"W
72"W

! Available in graphite finish only. No specification needed.

MODEL

HMPTROUGH48
HMPTROUGH60
HMPTROUGH72

SHIP WEIGHT

3.3
4.3
5.3

CUBE

5.3
6.8
8.3

LIST PRICE

\$396
\$436
\$479

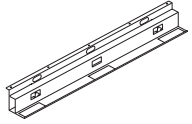

Trough — Single-Sided

48"W
60"W
72"W

! Available in graphite finish only. No specification needed.

HMPSTROUGH48
HMPSTROUGH60
HMPSTROUGH72

3.0
4.0
5.0

5.3
6.8
8.3

\$296
\$402
\$509

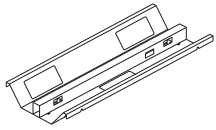

Trough — Double-Sided for 120° Applications

36"W
42"W
48"W

! Available in graphite finish only. No specification needed.

HMP120TROUGH36
HMP120TROUGH42
HMP120TROUGH48

6.9
8.4
9.9

3.8
3.8
5.3

\$322
\$357
\$396

NEW!

NOTES:

- Slots available in trough to zip tie data cables to the trough.
- Double-sided wire trough rests on top of support bars. No fasteners needed.
- Single-sided trough is used for single-sided applications only. Screws into bottom side of worksurface for attachment.

! For use with stationary Empower® only.

HOW TO SPECIFY

Select
Model Number

H M P T R O U G H 4 8



EMPOWER® Return Components

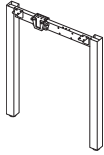

DESCRIPTION

Single Depth Return Leg (Singles)

Left
Right

NOTES: Return legs ship with two flat brackets.

MODEL	SHIP WEIGHT	CUBE	LIST PRICE BY PAINT GRADE		
			P1	P2	P3
HMPRELE2428	23.7	4.0	\$345	\$349	\$362
HMPRREL2428	23.7	4.0	\$345	\$349	\$362

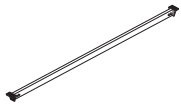

DESCRIPTION

Support Beams (Box of 1)

48"W
60"W

NOTES: For use with single-sided stations. 36"W returns will use the 48"W Support Beam and 48"W returns will use the 60"W Support Beam.

! Available in graphite finish only. No specification needed.

MODEL	SHIP WEIGHT	CUBE	LIST PRICE
HMPUB148	7.0	0.5	\$286
HMPUB160	8.3	0.7	\$319

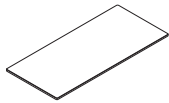

DESCRIPTION

24"D Worksurface with Edgeband

36"W x 24"D

NOTES: For use as a return surface only.

48"W x 24"D

NOTES: Can be used as a primary surface or a return surface.

MODEL	SHIP WEIGHT	CUBE	LIST PRICE BY LAMINATE GRADE	
			L1	L2
HWR2436PN	46 Ⓞ	2.5	\$346	\$361
HWR2448PN	58 Ⓞ	3.3	\$404	\$419

NOTES:

- Worksurfaces are constructed of laminate on 1/8" solid core high-performance particleboard.
- Return legs ship with two flat brackets. 36"W returns will use the 48"W Support Beam and 48"W returns will use the 60"W Support Beam.
- ! All worksurfaces load tested to BIFMA standards.
- ! Stack-on storage cannot be used on Empower® benching.
- ! For use with static linear applications only.

HOW TO SPECIFY

<p>Select Model Number</p> <p>H M P R L E L 2 4 2 8 .</p>	<p>Select Paint Color</p> <p>See page 478</p> <p>T 1</p>	
<p>Select Model Number</p> <p>H W R 2 4 3 6 P N .</p>	<p>Select Laminate Color</p> <p>See page 478</p> <p>L D W 1 .</p>	<p>Select Edgeband Color</p> <p>See page 478</p> <p>L D W 1</p>

EMPOWER[®] Systems Worksurfaces

GSA SIN 33721



Icon Legend on page 19

WORKSTATIONS

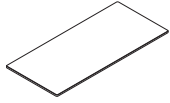

DESCRIPTION

24"D Worksurface with Edgeband

36"W x 24"D

NOTES: For use as a return surface only.

48"W x 24"D

NOTES: Can be used as a primary surface or a return surface.

60"W x 24"D

72"W x 24"D

NOTES: For use as a primary surface.

MODEL

HWR2436PN

HWR2448PN

HWR2460PN

HWR2472PN

SHIP WEIGHT

46

58

70

89

CUBE

2.5

3.3

4.0

4.8

LIST PRICE BY LAMINATE GRADE

L1

\$346

\$404

\$477

\$529

L2

\$361

\$419

\$497

\$549

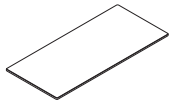

30"D Worksurface with Edgeband

48"W x 30"D

60"W x 30"D

72"W x 30"D

HWR3048PN

HWR3060PN

HWR3072PN

58

70

89

3.3

4.0

4.8

\$436

\$520

\$593

\$451

\$540

\$613

NOTES:

• Worksurfaces are constructed of laminate on 1 1/8" solid core high-performance particleboard.

- All worksurfaces load tested to BIFMA standards.
- Stack-on storage cannot be used on Empower[®] benching.
- Height adjustable worksurfaces are reduced 2" in width and 0.75" in depth to prevent pinch points.

HOW TO SPECIFY

Select Model Number

HWR2448PN

Select Laminate Color

See page 478

LDW1

Select Edgeband Color

See page 478

LDW1



SYSTEMS WORKSURFACES

120 Degree Corner

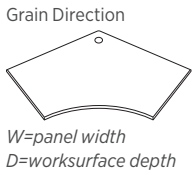

DESCRIPTION

Abound® and Accelerate® 120 Degree Corner Worksurfaces with Curved User Edge

36"W x 24"D
42"W x 24"D
48"W x 24"D

MODEL

HBWCT3624P
HBWCT4224P
HBWCT4824P

SHIP WEIGHT

75
96
107

CUBE

7.7
9.2
9.2

L1 LIST PRICE

\$777
\$833
\$965

L2 LIST PRICE

\$792
\$848
\$980

42"W x 30"D
48"W x 30"D

HBWCT4230P
HBWCT4830P

102
112

11.4
11.4

\$1094
\$1164

\$1109
\$1179

- HBWCT3624P will not accept the H4022, HE4022, H4028, or H4029 keyboard platforms.
- One small worksurface bracket standard with each worksurface.

❗ Corner worksurfaces must match exactly the panel behind them, i.e.: a 36" panel must be used on the back two sides of model HBWCT3624P.

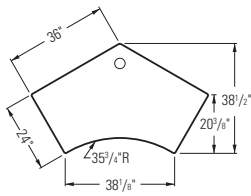

HBWCT3624P

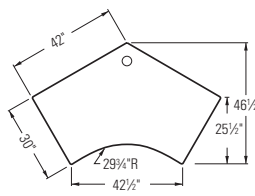

HBWCT4230P

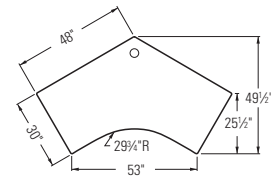

HBWCT4830P

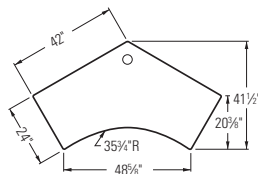

HBWCT4224P

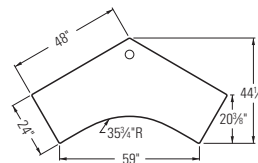

HBWCT4824P

NOTES:

- Worksurfaces are constructed of laminate on 1/8" solid core high-performance particleboard.
- Add suffix "N" to Model Number for worksurfaces with no grommets. No upcharge.
- Refer to Worksurface Supports, pages 604-608.
- If used at an end of run, full end panel needs to be ordered — see page 604.

- ❗ Cannot use keyboard tray or full height pedestal under 120 degree corner worksurface.
- ❗ For use with linear applications only.

HOW TO SPECIFY

<p>Select Model Number</p> <p>No Grommet option: Add "N" suffix (no upcharge)</p> <p>HBWCT3624P .</p> <p>HBWCT3624PN .</p>	<p>Select Laminate</p> <p>See page 455</p> <p>AS .</p> <p>AS .</p>	<p>Select Edge Color</p> <p>See page 455</p> <p>K .</p> <p>K .</p>	<p>Select Grommet Color</p> <p>See page 455</p> <p>T1</p>
---	---	---	--

EMPOWER® Height Adjustable Bases

OPEN MARKET

Icon Legend on page 19

WORKSTATIONS

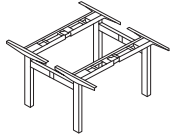

DESCRIPTION

Height Adjustable Base
Back-to-Back Workstation

MODEL

HMPHA2S4C

SHIP WEIGHT

130

CUBE

5.3

LIST PRICE

\$2286

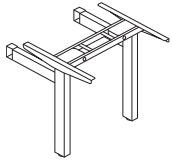

DESCRIPTION

End of Run Kit
! End of Run Kit needs to be attached to one side of HMPHA2S4C. End of Run Kit cannot stand on its own.

MODEL

HMPHABEORKIT

SHIP WEIGHT

15

CUBE

3.1

LIST PRICE

\$176

NOTES:

- Bases are steel construction with telescoping horizontal frame that adjusts from 41"-71"W to accommodate 42"-72"W worksurfaces. Memory controller features four memory presets, programmable upper and lower limit, and keypad lock to prevent unintentional movement. Dour motor with 250 lbs. load capacity per surface. Travel range of 19 5/8" adjustment from 25 3/8" to 45 1/4" (excluding worksurface dimension).
- ! Height adjustable benching cannot be single-sided; must always be used in back to back layouts.
- ! HBSMAUSB and HBDMAUSB cannot be used in Empower® height adjustable applications.

DESCRIPTION

Trough for Height Adjustable Base — Double-Sided
48"W
60"W
72"W

MODEL

HMPHATROUGH48
HMPHATROUGH60 ©
HMPHATROUGH72

SHIP WEIGHT

5.0
6.5
7.0

CUBE

1.7
2.2
2.7

LIST PRICE

\$396
\$436
\$479

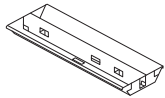

Trough for Height Adjustable End of Run
20"W

MODEL

HMPHATROUGH20

SHIP WEIGHT

3.0

CUBE

0.4

LIST PRICE

\$320

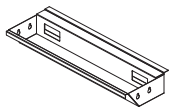

DESCRIPTION

Single-Sided Trough Lid — Single Pack
For 48"W Trough
For 60"W Trough
For 72"W Trough
For Height Adjustable Base 20"W End of Run Trough

HMPHASLID48
HMPHASLID60 ©
HMPHASLID72
HMPHASLID20

3.0
4.0
5.0
2.0

0.4
0.5
0.6
0.4

\$115
\$126
\$138
\$93

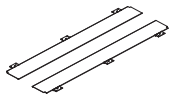

NOTES:

- Slots available in trough to zip tie data cables to the trough.
- Trough attaches to crossbeam connected to the height adjustable columns.
- 2 trough lids needed per double-sided trough.
- 1 trough lid needed for end of run trough.
- \$4 upcharge for P2 Paints.
- \$10 upcharge for P3 Paints on Trough Covers and End of Run Trough.
- \$20 upcharge for P3 Paints on Troughs.

HOW TO SPECIFY

Select Model Number H M P H A 2 S 4 C	Select Paint Color P71 Black P8L Nickel PD8 White P 8 L
---	--

Select Model Number H M P H A T R O U G H 4 8	Select Paint Color See page 478 P 8 S
---	--



Icon Legend on page 19

EMPOWER® Systems Worksurfaces

WORKSTATIONS

	DESCRIPTION	MODEL	SHIP WEIGHT	CUBE	LIST PRICE BY LAMINATE GRADE	
					L1	L2
	24"D Height Adjustable Worksurfaces					
	48"W x 24"D	HHAW2448PN Ⓢ	58	3.1	\$429	\$444
	60"W x 24"D	HHAW2460PN Ⓢ	70	3.9	\$499	\$519
	72"W x 24"D	HHAW2472PN	89	4.6	\$552	\$572
	30"D Height Adjustable Worksurfaces					
	48"W x 30"D	HHAW3048PN	68	3.9	\$458	\$473
	60"W x 30"D	HHAW3060PN Ⓢ	101	4.8	\$544	\$564
	72"W x 30"D	HHAW3072PN	105	5.7	\$616	\$636
	Half-Round Worksurfaces for End of Run					
	50"W x 30"D	HHAWD2450PN	54	4.8	\$618	\$633
	62"W x 30"D	HHAWD3062PN	77	5.9	\$720	\$740

OPEN MARKET

NOTES:

- Worksurfaces are constructed of laminate on 1 1/8" solid core high-performance particleboard.
- ! All worksurfaces load tested to BIFMA standards.
- ! Stack-on storage cannot be used on Empower® benching.
- ! Height adjustable worksurfaces are reduced 2" in width and 0.75" in depth to prevent pinch points.

HOW TO SPECIFY

<p>Select Model Number</p> <p>HHAW2448PN.</p>	<p>Select Laminate Color</p> <p>See page 478</p> <p>WHIT.</p>	<p>Select Edgeband Color</p> <p>See page 478</p> <p>WHIT</p>
--	--	---

EMPOWER® Side Screens

GSA SIN 33721



Icon Legend on page 19

WORKSTATIONS

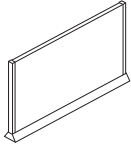

DESCRIPTION

Fabric Side Screen

24"D x 13"H
24"D x 20"H

30"D x 13"H
30"D x 20"H

MODEL

HMPDFS2413 ©
HMPDFS2420

HMPDFS3013
HMPDFS3020

SHIP WEIGHT CUBE

4.5	2.1
4.5	1.6
5.0	1.9
5.0	2.2

LIST PRICE BY FABRIC GRADE

AA	A	B
\$398	\$418	\$438
\$440	\$460	\$480
\$439	\$459	\$479
\$484	\$504	\$524

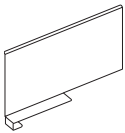

DESCRIPTION

Painted Metal Side Screen

24"D x 13"H
30"D x 13"H

MODEL

HMPDMS2413
HMPDMS3013

SHIP WEIGHT CUBE

6.3	2.0
7.7	2.8

LIST PRICE BY PAINT GRADE

P1	P2	P3
\$280	\$284	\$300
\$322	\$326	\$342

NOTES:

- Fabric screen adheres to the top of the worksurface with heavy-duty double stick tape.
- Metal screen slides over the edge of the worksurface and screws in under the worksurface.
- Metal screen is available in markerboard paint.
- For use on stationary and height adjustable setups.

HOW TO SPECIFY

<p>Select Model Number</p> <p>H M P D F S 2 4 1 3 .</p>	<p>Select Paint Color</p> <p>See page 478</p> <p>T 1 .</p>	<p>Select Fabric</p> <p>See pages 476-477</p> <p>A P N 1 1</p>
<p>Select Model Number</p> <p>H M P D M S 2 4 1 3 .</p>	<p>Select Paint Color</p> <p>See page 478</p> <p>P 8 S</p>	



Icon Legend on page 19

EMPOWER® Center Screens Fabric

WORKSTATIONS

	DESCRIPTION	MODEL	SHIP WEIGHT	CUBE	LIST PRICE BY FABRIC GRADE			
					AA	A	B	
	Fabric Screens (Shared) — 13”H							
	24”W	HMPCFS2413	6.3	0.9	\$299	\$319	\$339	
	30”W	HMPCFS3013	7.3	1.1	\$371	\$391	\$411	
	36”W	HMPCFS3613	8.3	1.4	\$453	\$473	\$493	
	42”W	HMPCFS4213	9.3	1.6	\$466	\$486	\$506	
	48”W	HMPCFS4813	10.3	1.8	\$576	\$596	\$616	
	60”W	HMPCFS6013	12.3	2.3	\$663	\$683	\$703	
	! For use on stationary stations only.							
		Fabric Screens (Shared) — 20”H						
		24”W	HMPCFS2420	7.3	1.6	\$381	\$401	\$421
30”W		HMPCFS3020	8.5	1.6	\$474	\$494	\$514	
36”W		HMPCFS3620	9.8	2.1	\$577	\$597	\$617	
42”W		HMPCFS4220	11.0	2.4	\$554	\$574	\$594	
48”W		HMPCFS4820	12.3	2.8	\$656	\$676	\$696	
60”W		HMPCFS6020	14.8	3.5	\$727	\$747	\$767	
! For use on stationary stations only.								
		Fabric Screens (Single) — 13”H						
		36”W	HMPFSS3613	9.7	2.4	\$448	\$468	\$488
	42”W	HMPFSS4213	11.0	1.7	\$461	\$481	\$501	
	48”W	HMPFSS4813	12.3	2.9	\$571	\$591	\$611	
	54”W	HMPFSS5413	13.6	2.4	\$600	\$620	\$640	
	60”W	HMPFSS6013	14.8	3.6	\$658	\$678	\$698	
OPEN MARKET	NOTES: For use on single-sided stationary stations or height adjustable stations (one per worksurface).							
	Fabric Screens (Single) — 20”H							
	36”W	HMPFSS3620	11.2	3.2	\$572	\$592	\$612	
	42”W	HMPFSS4220	12.8	2.7	\$549	\$569	\$589	
	48”W	HMPFSS4820	14.3	4.0	\$651	\$671	\$691	
	54”W	HMPFSS5420	15.9	3.6	\$682	\$702	\$722	
	60”W	HMPFSS6020	17.3	4.9	\$722	\$742	\$762	
OPEN MARKET	NOTES: For use on single-sided stationary stations or height adjustable stations (one per worksurface).							

NOTES:

- ! Only single-sided screens can be specified with height adjustable workstations.
- ! When using a power pole, the screen on the station with the pole must be 6” shorter to allow space for the pole to be mounted.

Fabric Screen Specifying Guide

Static Rectangle Worksurface Width	Inset 6” on Each Side	Full Length
48”	36”	48”
60”	48”	60”
72”	60”	N/A

120 Side Width	Inset 6” on Each Side	Full Length
36”	24”	36”
42”	30”	42”
48”	36”	48”

Height Adjustable Rectangle Worksurface Width	Inset 5” on Each Side	Inset 2” on Each Side
48” (undersized)	36”	42”
60” (undersized)	48”	54”
72” (undersized)	60”	N/A

HOW TO SPECIFY

<p>Select Model Number</p> <p>H M P C F S 3 6 2 0 .</p>	<p>Select Paint Color</p> <p>See page 478 \$4 upcharge for P2 Paints \$20 upcharge for P3 Paints</p> <p>T 1 .</p>	<p>Select Fabric</p> <p>See pages 476-477</p> <p>A P N 1 1</p>
--	--	---

EMPOWER® Center Screens Frosted Glass

GSA SIN 33721



Icon Legend on page 19

WORKSTATIONS

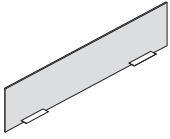

DESCRIPTION

Frosted Glass Screens (Shared) — 13”H

24”W
30”W
36”W
42”W
48”W
60”W
72”W

MODEL

SHIP WEIGHT CUBE

LIST PRICE BY PAINT GRADE

P1 P2

HMPFG2413	18.2	1.4	\$329	\$333
HMPFG3013	21.0	1.6	\$408	\$412
HMPFG3613	23.8	1.9	\$497	\$501
HMPFG4213	26.5	2.2	\$514	\$518
HMPFG4813	29.3	2.4	\$608	\$612
HMPFG6013	35.3	3.0	\$728	\$732
HMPFG7213	43.3	3.5	\$800	\$804

! For use on stationary stations only.

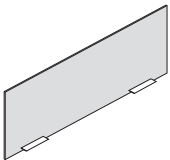

Frosted Glass Screens (Shared) — 20”H

24”W
30”W
36”W
42”W
48”W
60”W
72”W

HMPFG2420	24.8	2.0	\$418	\$422
HMPFG3020	28.8	2.4	\$521	\$525
HMPFG3620	32.8	2.8	\$608	\$612
HMPFG4220	37.3	3.1	\$609	\$613
HMPFG4820	41.3	3.5	\$719	\$723
HMPFG6020	49.3	4.3	\$799	\$803
HMPFG7220	60.3	5.1	\$878	\$882

! For use on stationary stations only.

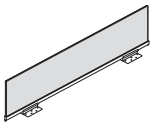

Frosted Glass Screens (Single) — 13”H

36”W
42”W
48”W
54”W
60”W
72”W

HMPFGS3613	25.2	1.9	\$492	\$496
HMPFGS4213	28.3	2.2	\$509	\$513
HMPFGS4813	31.3	2.4	\$603	\$607
HMPFGS5413	34.4	2.8	\$660	\$664
HMPFGS6013	37.8	3.0	\$723	\$727
HMPFGS7213	46.3	3.5	\$795	\$799

NOTES: For use on single-sided stationary stations or height adjustable stations (one per worksurface).

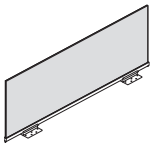

Frosted Glass Screens (Single) — 20”H

36”W
42”W
48”W
54”W
60”W
72”W

HMPFGS3620	34.2	2.8	\$603	\$607
HMPFGS4220	38.8	3.1	\$604	\$608
HMPFGS4820	43.3	3.5	\$714	\$718
HMPFGS5420	47.9	3.8	\$751	\$755
HMPFGS6020	51.8	4.3	\$794	\$798
HMPFGS7220	63.3	5.1	\$873	\$877

NOTES: For use on single-sided stationary stations or height adjustable stations (one per worksurface).

! 20”H glass cannot be used on 24”D single-sided stations.

NOTES:

- ! Only single-sided screens can be specified with height adjustable workstations.
- ! When using a power pole, the screen on the station with the pole must be 6” shorter to allow space for the pole to be mounted.

Glass Screen Specifying Guide

Rectangle Worksurface Width	Inset 6” on Each Side	Full Length
48”	36”	48”
60”	48”	60”
72”	60”	72”

120 Side Width	Inset 6” on Each Side	Full Length
36”	24”	36”
42”	30”	42”
48”	36”	48”

Height Adjustable Rectangle Worksurface Width	Inset 5” on Each Side	Inset 2” on Each Side
48” (undersized)	36”	42”
60” (undersized)	48”	54”
72” (undersized)	60”	N/A

HOW TO SPECIFY

<p>Select Model Number</p> <p>H M P F G 3 6 1 3 .</p>	<p>Select Paint Color</p> <p>See page 478</p> <p>T 1 .</p>	<p>Select Frosted Glass</p> <p>R Frosted Glass</p> <p>R</p>
---	--	---



Icon Legend on page 19

Modesty Panels/End of Run Screens

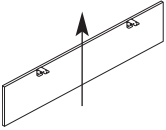
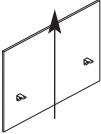
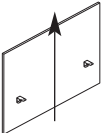
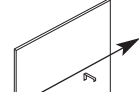
DESCRIPTION	MODEL	SHIP WEIGHT	CUBE	LIST PRICE BY LAMINATE GRADE	
				L1	L2
 <p>Laminate Modesty Panels — 13”H 36”W for use with 48”W Worksurfaces 48”W for use with 60”W Worksurfaces 60”W for use with 72”W Worksurfaces NOTES: Vertical grain. ⓘ For use on single-sided stationary Empower® only.</p>	HMPLM3613	12.9	1.9	\$182	\$192
	HMPLM4813	16.9	2.4	\$273	\$283
	HMPLM6013	19.9	2.9	\$311	\$321
 <p>Single-Side Laminate End of Run Screens Single — 24”W x 26”H Single — 24”W x 34”H Single — 30”W x 26”H Single — 30”W x 34”H NOTES: 24”W and 48”W models used on 24”D Worksurfaces and 30”W and 60”W models are used on 30”D Worksurfaces. Vertical grain.</p>	HMPLM2426	16.9	2.2	\$185	\$195
	HMPLM2434	20.9	2.8	\$202	\$212
	HMPLM3026	20.5	2.7	\$210	\$220
	HMPLM3034	25.5	3.4	\$232	\$242
 <p>Double-Side Laminate End of Run Screens Double — 48”W x 26”H Double — 48”W x 34”H Double — 60”W x 26”H Double — 60”W x 34”H NOTES: 24”W and 48”W models used on 24”D Worksurfaces and 30”W and 60”W models are used on 30”D Worksurfaces. Vertical grain.</p>	HMPLM4826	30.9	4.1	\$270	\$280
	HMPLM4834	38.9	5.2	\$296	\$306
	HMPLM6026	38.1	5.1	\$365	\$375
	HMPLM6034	48.3	6.4	\$396	\$406
 <p>Double-Side Laminate Gallery Panel for Height Adjustable 48”W x 50”H 60”W x 50”H NOTES: Horizontal grain.</p>	HMPLGP4850	82.0	6.6	\$615	\$625
	HMPLGP6050	100.0	9.2	\$682	\$692

OPEN MARKET

NOTES:

- End of run screens sit -1” inset on each side of the depth of the run.
- Static end of run screens are 13” below the surface and either 13”H or 20”H above the surface.
- Height adjustable end of run screens extend to the floor and are 50”H.

HOW TO SPECIFY

<p>Select Model Number</p> <p>HMPLM3613</p>	<p>Select Laminate Color</p> <p>See page 478</p> <p>PINCPINC</p>	<p>Select Paint Color</p> <p>Bracket paint must be specified</p> <p>T1</p>
--	---	---

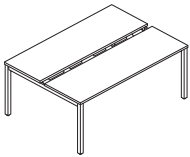
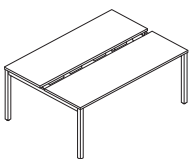
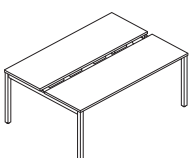
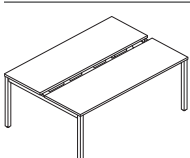
	DESCRIPTION	MODEL	SHIP WEIGHT	CUBE	LIST PRICE BY LAMINATE GRADE	
					L1	L2
	Bundles — 72" W with 24" D Worksurfaces					
	2-Pack	HMP2472PK2	238.9	35.3	\$3770	\$3810
	4-Pack	HMP2472PK4	465.8	59.4	\$6863	\$6943
	6-Pack	HMP2472PK6	692.7	83.9	\$9956	\$10076
	8-Pack	HMP2472PK8	919.6	108.5	\$13049	\$13209
	Bundles — 60" W with 24" D Worksurfaces					
	2-Pack	HMP2460PK2	198.9	35.3	\$3554	\$3594
	4-Pack	HMP2460PK4	385.8	59.4	\$6431	\$6511
	6-Pack	HMP2460PK6	572.7	83.9	\$9308	\$9428
	8-Pack	HMP2460PK8	759.6	108.5	\$12185	\$12345
	Bundles — 72" W with 30" D Worksurfaces					
	2-Pack	HMP3072PK2	238.9	35.3	\$4011	\$4051
	4-Pack	HMP3072PK4	465.8	59.4	\$7278	\$7358
	6-Pack	HMP3072PK6	692.7	83.9	\$10545	\$10665
	8-Pack	HMP3072PK8	919.6	108.5	\$13812	\$13972
	Bundles — 60" W with 30" D Worksurfaces					
	2-Pack	HMP3060PK2	198.9	35.3	\$3753	\$3793
	4-Pack	HMP3060PK4	385.8	59.4	\$6762	\$6842
	6-Pack	HMP3060PK6	572.7	83.9	\$9771	\$9891
	8-Pack	HMP3060PK8	759.6	108.5	\$12780	\$12940
SPECIFYING EXAMPLE: Model.Laminate.Edgeband.Paint2.DuplexColor (S only)						

NOTES:

- Bundles include worksurfaces, support legs, support bars, wire management troughs, harnesses, and duplexes.
- Please specify in-feed, screens, storage, and seating separately.

ⓘ Stack-on storage cannot be used on Empower benching.

HOW TO SPECIFY

<p>Select Model Number</p> <p>See page 478</p> <p>HMP2472PK2</p>	<p>Select Laminate Color</p> <p>See page 478</p> <p>LDW1</p>	<p>Select Edgeband Color</p> <p>See page 478</p> <p>LDW1</p>	<p>Select Paint Color</p> <p>See page 478</p> <p>\$4 upcharge for P2 Paints</p> <p>T1</p>	<p>Select Duplex Color</p> <p>See page 478</p> <p>S</p>
---	---	---	--	--



EMPOWER® Height Adjustable Typicals

	DESCRIPTION	MODEL	SHIP WEIGHT	CUBE	LIST PRICE BY LAMINATE GRADE	
					L1	L2
	Bundles — 72" W with 24" D Worksurfaces					
	2-Pack	HMPHA2472PK2	331	19.1	\$4538	\$4578
	4-Pack	HMPHA2472PK4	662	37.6	\$9067	\$9147
	6-Pack	HMPHA2472PK6	993	56.2	\$13596	\$13716
	8-Pack	HMPHA2472PK8	1324	74.7	\$18125	\$18285
	Bundles — 60" W with 24" D Worksurfaces					
	2-Pack	HMPHA2460PK2	291	16.9	\$4365	\$4405
	4-Pack	HMPHA2460PK4	581	33.1	\$8721	\$8801
	6-Pack	HMPHA2460PK6	872	49.4	\$13077	\$13197
	8-Pack	HMPHA2460PK8	1162	65.7	\$17433	\$17593
	Bundles — 72" W with 30" D Worksurfaces					
	2-Pack	HMPHA3072PK2	363	21.3	\$4666	\$4706
	4-Pack	HMPHA3072PK4	726	41.9	\$9323	\$9403
	6-Pack	HMPHA3072PK6	1089	62.6	\$13980	\$14100
	8-Pack	HMPHA3072PK8	1452	83.3	\$18637	\$18797
	Bundles — 60" W with 30" D Worksurfaces					
	2-Pack	HMPHA3060PK2	353	18.7	\$4455	\$4495
	4-Pack	HMPHA3060PK4	705	36.7	\$8901	\$8981
	6-Pack	HMPHA3060PK6	1058	54.8	\$13347	\$13467
	8-Pack	HMPHA3060PK8	1410	72.9	\$17793	\$17953

SPECIFYING EXAMPLE: Model.Laminate.Edgeband.BasePaint.TroughPaint.DuplexColor

NOTES:

- Bundles include worksurfaces, wire management troughs, trough covers, harnesses, duplexes, and bases.
- Please specify in-feed, screens, storage, and seating separately.

- ❗ Stack-on storage cannot be used on Empower benching.
- ❗ HBSMAUSB and HBDMAUSB cannot be used in Empower® height adjustable applications.

HOW TO SPECIFY

<p>Select Model Number</p> <p>H M P H A 2 4 7 2 P K 2 .</p>	<p>Select Laminate Color</p> <p>See page 478</p> <p>L D W 1 .</p>	<p>Select Edgeband Color</p> <p>See page 478</p> <p>L D W 1 .</p>	<p>Select Base Paint Color</p> <p>See page 478</p> <p>Upcharge for P2 and P3 Paints</p> <p>T 1 .</p>	<p>Select Trough Paint Color</p> <p>See page 478</p> <p>S .</p>	<p>Select Duplex Color</p> <p>See page 478</p> <p>S .</p>
---	---	---	--	---	---

EMPOWER® ELECTRICAL SPECIFYING INFORMATION

To Order:

1. Determine which electrical system you will use after consulting your electrician and computer support personnel:

- **The Four-circuit system (4-Hot/2-Neutral/2-Ground)**
 - 3 + 1 option
 - 2 + 2 option
- **The Three-circuit system (3-Hot/3-Neutral/2-Ground)**

2. Determine location, quantity and circuit of duplexes.
3. Determine the appropriate choice and use of Isolated, Isolated/Dedicated and Separate Neutral circuits.
4. Specify appropriate Power Harnesses* and Pass-Thru Cables.*
5. Determine the location, quantity and type of Power In-feed needed.

* Select Power Harness models (HH8712XX) and Pass-Thru Cables (HH8711XX) with the last two digits being the same as the associated worksurface width.

Electrical System Options

The four-circuit, eight-wire electrical system is widely specified and trusted by hundreds of thousands of end-users. This proven system delivers four circuits for every power in-feed in either a 3 + 1 or 2 + 2 configuration. The isolated/dedicated circuits are ideal for sensitive computing equipment, while the common circuits are suitable for faxes, copiers, task lights and other peripherals.

Both the 3 + 1 and 2 + 2 systems use the same pre-wired components, making it easy to adjust as electrical needs change.

You can also choose a three-circuit, eight-wire system that has a dedicated neutral for every hot circuit. The three-circuit components have model numbers with an "A" suffix and appear in a gray box in this pricer.

Four-circuit, 3 + 1 Receptacle Option

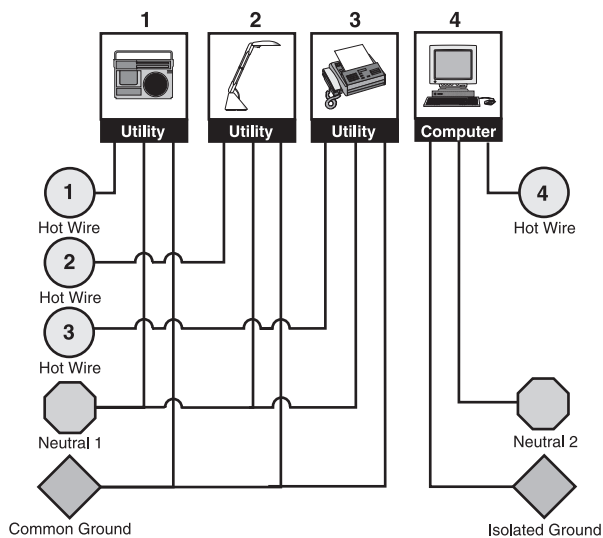

The 3 + 1 option is the electrical standard used by The HON Company for many years in most of their systems products. This wiring option provides three utility circuits plus an isolated/dedicated circuit for more sensitive equipment.

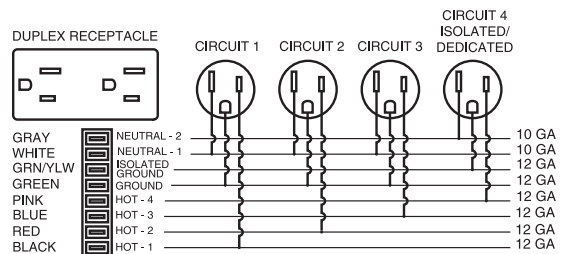

Four-circuit, 2 + 2 Receptacle Option

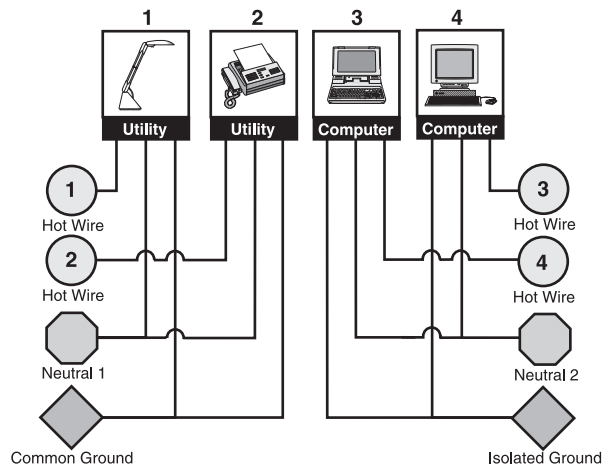

The 2 + 2 option is a wiring option that provides two utility circuits and two isolated circuits for more extensive computer usage applications.

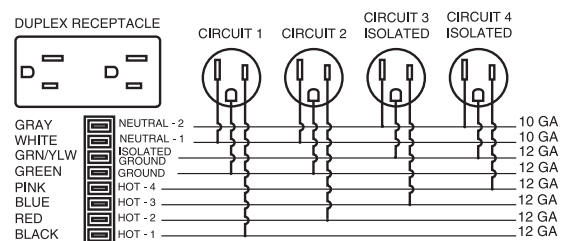

EMPOWER[®] ELECTRICAL SPECIFYING INFORMATION

Three-circuit, separate neutrals

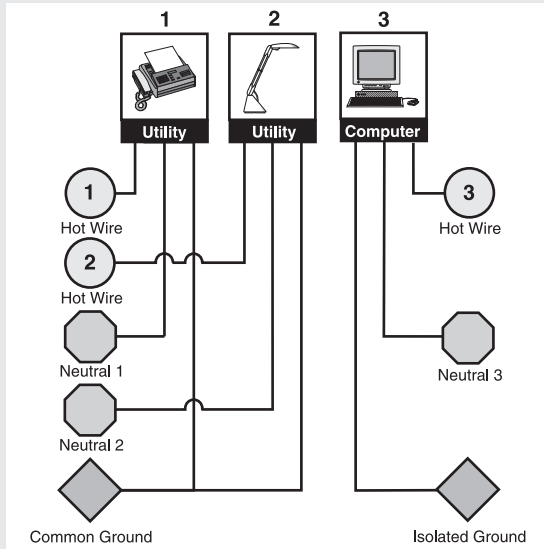

The Three-circuit, separate neutrals configuration is a wiring option that provides separate neutrals for each of the three circuits. Two circuits share a common ground, and one circuit is isolated/dedicated. The three-circuit components have model numbers with an "A" suffix and appear in a gray box in this pricer.

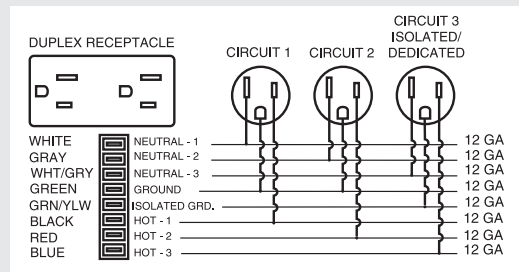

Two 8-wire, 20 AMP (15 AMP Canadian) electrical systems are offered					
Electrical System	Circuitry	Receptacle Capacity			
Four-circuit 4-Hot/2-Neutral/2-Ground (10 gauge neutral wires)	3 + 1	Common Circuit-1 HH873501	Common Circuit-2 (1) HH873502	Common Circuit-3 HH873503	Iso/Dedicated Circuit-4 HH873504
	2 + 2	Common Circuit-1 HH873501	Common Circuit-2 HH873502	Isolated Circuit-3 HH873506	Isolated Circuit-4 HH873504
Three-circuit 3-Hot/3-Neutral/2-Ground (12 gauge neutral wires)	w/separate neutrals	Common Circuit-1 HH873501A	Common Circuit-2 HH873502A	Iso/Dedicated Circuit-3 HH873503A	N/A

(1) Circuit-2 (one of the 3 common circuits sharing a neutral wire) cannot be used with a single-phase building electrical supply.

Notes:

- Four-circuit components and three-circuit components (with suffix "A") cannot be used together.
- Components of the two systems are keyed differently to prevent components of one system from being connected to components of another system.
- HON Cat. Nos. are printed on the UL labels, and components are color-coded to provide visual identification of the different components.
- Four-circuit components have black plastic parts.
- Three-circuit components have rust-colored terminal ends and receptacle backs are rust colored.

Typical power usage by the most commonly specified office equipment.

Source: Industry Analysis, Inc., Rochester, NY

EQUIPMENT	AMPS	EQUIPMENT	AMPS	EQUIPMENT	AMPS
Computers		Copiers		FAX Machines	
Personal Computer	3	Desktop Copier	15	InkJet FAX	less than 1
Notebook Computer	3	Console Copier	20	Thermal FAX	less than 1
		Copier/Duplicator	30	Plain paper FAX	8
Monitors		Printers		Task Lights	
13" Color Monitor	2	Dot Matrix	less than 1	36" T8 Fluorescent	0.2/bulb
17" Color Monitor	3	InkJet	less than 1	48" T8 Fluorescent	0.3/bulb
21" Color Monitor	4	Personal Laser or LED	8		
		Workgroup Laser or LED	15		

Duplex Receptacles



15 AMP Receptacle

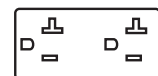

20 AMP Receptacle
(Required by some large copiers.)

EMPOWER[®] ELECTRICAL SPECIFYING INFORMATION

- Electrical components are UL Listed and CSA Certified.
- It is the customer's responsibility to ensure that use of the pre-wired electrical system, the number of receptacles used on a given circuit, and connection to a building power source, be in compliance with all local and national electrical codes.
- Contact Customer Service for additional information.
- Four-circuit components and Three-circuit components (with suffix "A") cannot be used together. See pages 514-515.
- ! A licensed electrician must make connections to a building electrical supply.

Definition of components:

Electrical Power Harness



- Used to distribute power in workstations.
- Power distribution in either direction.
- Specify Power Harness to match workstation width.
- Double-sided: receptacles can be inserted into both sides of Power Blocks.

Electrical Pass-Thru Cables

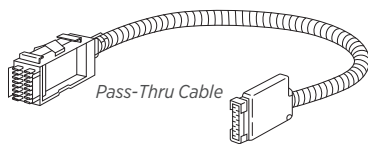

Pass-Thru Cable With Duplex Capacity:

- Use in workstations where multiple receptacles are not required.
- Added feature: has capacity for one receptacle on each side of a workstation. Feature offers future expansion and is an alternative to Power Harnesses.

Duplex Receptacles

- 15 amp outlet configuration.
- Models HH871601 and HH871601A have a 20 amp outlet configuration.
- Fit back-to-back into the Power Block(s) of Power and Pass-Thru Harnesses.
- Labeled with the provided circuit. Circuits connected to the Isolated Ground are identified with an orange triangle; circuits that do not share a neutral or ground have an orange circuit number.

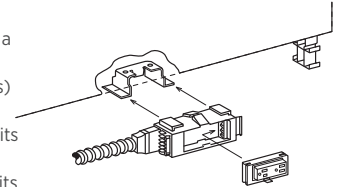

Power In-Feed Model (Floor or Ceiling) HMP144

- Used to connect the workstation electrical system to the building electrical supply.
- ! A licensed electrician must make connections to a building electrical supply.
- ! Conduit is UL listed Black Liquid-tight conduit (outside diameter is 7/8").

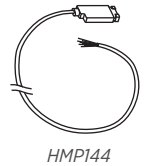

Note: In-feed cables listed above may be field-cut to desired length.

3-Pack 120 Degree Electric Specification Guide

	A	B
36" 120 surface	HH871124	HH871148
42" 120 surface	HH871124	HH871160
48" 120 surface	HH871124	HH871172

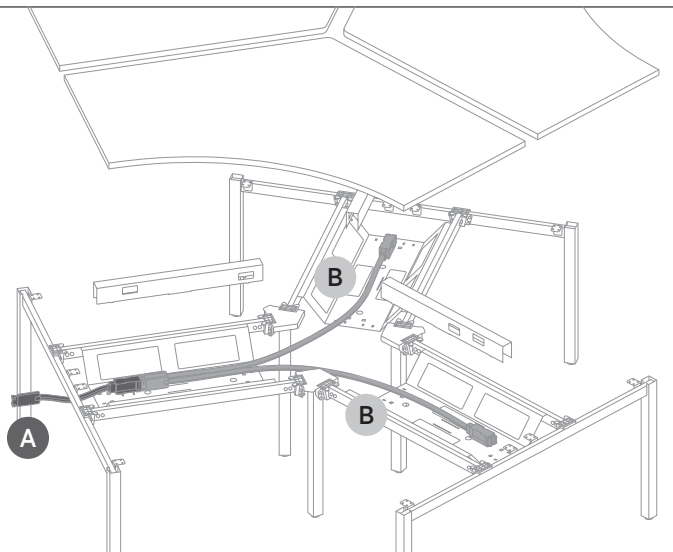

EMPOWER[®] ELECTRICAL SPECIFYING INFORMATION

- Electrical components are UL Listed and CSA Certified.
- It is the customer's responsibility to ensure that use of the pre-wired electrical system, the number of receptacles used on a given circuit, and connection to a building power source, be in compliance with all local and national electrical codes.
- ! A licensed electrician must make connections to a building electrical supply.

Vertebrae:
17 Cables, 0.250 Diameter (CAT-6)

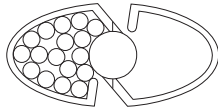

Single-Depth Cable Trough Cover Capacity:
13 Cables, 0.250 Diameter (CAT-6)

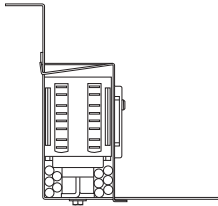

Double-Depth Cable Trough Cover Capacity:
14 Cables, 0.250 Diameter (CAT-6)

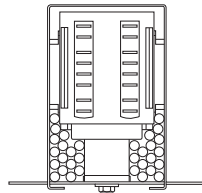

Data Cable Packing in Power Pole:
33 Cables, 0.250 Diameter (CAT-6)

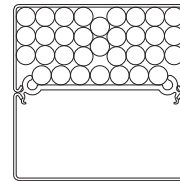

Data Cable Packing in Wire Trough Cover:
14 Cables, 0.250 Diameter (CAT-6)

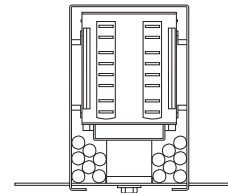

EMPOWER® Electrical and Data

GSA SIN 33721 EXCEPT AS NOTED



Icon Legend on page 19

WORKSTATIONS

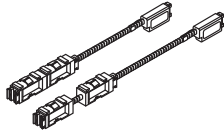
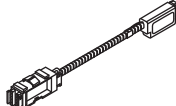
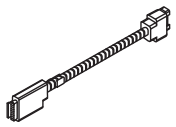
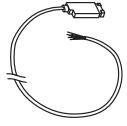
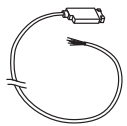
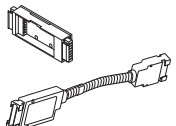
	DESCRIPTION	MAX. RECEPT. CAP. PER PANEL SIDE	MODEL		SHIP WEIGHT	CUBE	LIST PRICE
			FOUR-CIRCUIT 3+1 2+2	THREE-CIRCUIT, SEPARATE NEUTRALS			
	Electrical Power Harnesses, Frames — w/duplex capacity						
	For 48"W	2	HH871248 ☉	HH871248A	3.0 ☉	0.5	\$216
	For 60"W	2	HH871260 ☉	HH871260A	3.0 ☉	0.5	\$216
	For 72"W	2	HH871272	HH871272A	5.0 ☉	0.5	\$216
	Electrical Pass-Thru Cables, Frames — w/duplex capacity						
	For 48"W	1	HH871148 ☉	HH871148A	2.5 ☉	0.5	\$136
	For 60"W	1	HH871160 ☉	HH871160A	3.0 ☉	0.5	\$136
	For 72"W	1	HH871172	HH871172A	5.0 ☉	0.5	\$136
	Electrical Pass-Thru Harness without Power Block						
	For 24"W Frames	0	HH871024	HH871024A	2.0 ☉	0.5	\$119
	For 48"W Frames	0	HH871048	HH871048A	3.0 ☉	0.5	\$124
	For 60"W Frames	0	HH871060	HH871060A	3.0 ☉	0.5	\$124
	For 72"W Frame Runs	0	HH871072		4.0 ☉	0.5	\$171
<p>! 24" Pass-Thru Harness without Power Block is only used when specifying Power In-Feed with Sealtight as a floor in-feed. Harness is not needed for the standard in-feed.</p>							
	Power In-Feed — Sealtight						
	144" long conduit, Sealtight Cable — 7/8" diameter		HMP144		7.0	1.2	\$333
<p>NOTES: For use as ceiling, floor and wall in-feed. If three-circuit, separate neutral in-feed is required, please contact Tailored Solutions.</p>							
	Metal Flexible Conduit						
	144" long conduit, Flex Cable — 7/8" dia.		HMP1912		4.0 ☉	0.5	\$238
<p>NOTES: Metal Flexible Conduit. Best option for use with power pole due to bend radius flexibility.</p>							
	Power Jumper						
	For End of Run		HMPJUMP		2.0	0.3	\$170
<p>OPEN MARKET</p>							

HOW TO SPECIFY

Select
Model Number

HH871248

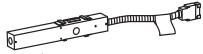

Use when local codes require



Each marked with
Circuit Number

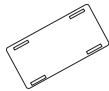

DESCRIPTION	MODEL		SHIP WEIGHT	CUBE	LIST PRICE
	FOUR-CIRCUIT 3 + 1 2 + 2	THREE-CIRCUIT, SEPARATE NEUTRALS			
Hardwire Applications Hardwire Power In-feed	HH871400	HH871400A	4.0	0.3	\$224
⚠ Customer to furnish all cabling and wiring from power entry to power source (approved for use by city of New York).					
Hardwire Junction Box (6-pack)	HH871500		4.5	0.1	\$477
⚠ Hardwire Junction Boxes cannot be installed back-to-back in panel applications.					
⚠ Contact Tailored Solutions for back-to-back Junction Box standard special number.					
Duplex Receptacles					
Circuit 1	HH871501 Ⓞ	HH871501A	1.0	0.5	\$42
Circuit 2	HH871502 Ⓞ	HH871502A	1.0	0.5	\$42
Circuit 3 (except 2 + 2 — see below)	HH871503 Ⓞ	HH871503A	1.0	0.5	\$42
Circuit 4 — isolated, dedicated circuit	HH871504		1.0	0.5	\$42
Circuit 1 (20 amp outlet configuration)	HH871601		1.0	0.5	\$42
Circuit 3 (2 + 2)	HH871506		1.0	0.5	\$42
Specify Paint. Charcoal (S) matches Empower trough.					

DESCRIPTION	MODEL	SHIP WEIGHT	CUBE	LIST PRICE
Receptacle Cover Replacements				
Quantity 25	HERECPCVR	1.0	0.1	\$74
⚠ Specify Color—Available in Black (P), Muslin (T3) and Shadow (SHDW) only.				

NOTES:

- ⚠ Customer must furnish conduit, wiring and designer type receptacles. (Approved for use by city of Chicago.)
- ⚠ Junction boxes cannot be used back-to-back.

Duplex Color Recommended to Coordinate with Paint Color			
Paint Color	Paint Code	Duplex Color	Duplex Code
Black	P	Black	P
Brownstone	P7D	Brownstone	EY
Charcoal	S	Charcoal	S
Designer White	PJW	Designer White	DW
Fossil	P28	Charcoal	S
Greige	T5	Muslin	T3
Light Gray	Q	Loft	LOFT
Loft	LOFT	Loft	LOFT
Muslin	T3	Muslin	T3
Putty	L	Black	P
Shadow	SHDW	Muslin	T3
Silver	PR6	Titanium	TI
Titanium	P8T	Titanium	TI
Champagne Metallic	T4	Muslin	T3
Platinum Metallic	T1	Titanium	Ti

HOW TO SPECIFY

<p>Select Model Number</p> <p>HH871400 .</p>	<p>Select Paint Color</p> <p>See page 478</p> <p>P</p>
--	--

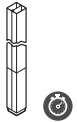

DESCRIPTION

Power Pole
10'5"

MODEL

HMPPP125

SHIP WEIGHT

14

CUBE

0.7

LIST PRICE

P1

\$464

NOTES: Power Pole ships with bracket to attach under stationary Empower® worksurfaces and feed directly into the Wire Management Trough. Power Pole will run to the floor on height adjustable Empower®.



DESCRIPTION

Vertebrae

MODEL

HMPVWM28

SHIP WEIGHT

3.0

CUBE

0.3

LIST PRICE

\$223

NOTES: 30"H x 3 1/8"W x 1 1/2"D. Ships unassembled. For additional information see the Workplace Tools section in the 2021 Shared Spaces Pricer. For use with stationary Empower®.

! Clear finish. Specify "X" for finish option.

SPECIFYING EXAMPLE: HMPVWM28.X

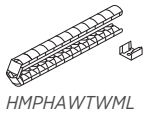

HMPHAWTWML



HMPHATFWML

Wire Managers for Height Adjustable

Workstation to Trough
Trough to Floor

MODEL

HMPHAWTWML !
HMPHATFWML

SHIP WEIGHT

3.0

CUBE

0.1

LIST PRICE

\$267

! Wire Manager Workstation to Trough only available in black.

! HMPHATFWML Trough to Floor cable manager is 3" x 1 1/2".

OPEN MARKET

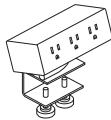

Model HPWRMOD3WC shown

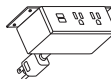

Model HPWRMOD2UWM shown

Power Modules

3 Receptacles with Worksurface Clamp
3 Receptacles with Under-Worksurface Mounting Bracket
2 Receptacles 2 USB with Worksurface Clamp
2 Receptacles 2 USB with Under-Worksurface Mounting Bracket

MODEL

HPWRMOD3WC !

HPWRMOD3UWM

HPWRMOD2WC !

HPWRMOD2UWM

2.3 \$

2.3

2.3

2.3

0.2

0.2

0.2

0.2

\$310

\$310

\$496

\$496

- 6' power cord with standard three-prong plug.
- Under-worksurface mounting bracket models work with any top that has a 5" x 5" square clearance.
- Worksurface clamp models work on any top with a 4" overhang.
- UL Listed.

NOTES: For additional information see the Workplace Tools section in the 2021 Shared Spaces Pricer.

! Color finish coordinates with HON's Charcoal or White. Specify STRM for Storm or SNW for Snow when ordering. Example: HPWRMOD3WC.STRM.

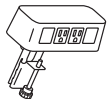

Power & Data Center

2 Receptacles 2 Data Accessory
• Standard with two receptacles and openings for two data ports.
• 6' power cord with standard three-prong plug.
• Fits on any worksurface with a 4" overhang.
• UL Listed.

HCOMDOME2

2.5 \$

0.2

\$296

NOTES: For additional information see the Workplace Tools section in the 2021 Shared Spaces Pricer.

! Color finish coordinates with HON's Loft. Specify LOFT when ordering. Example: HCOMDOME2.LOFT



Under Worksurface Power Module — 4 Outlets, 10' Cord

- Includes 10' cord with three-prong plug.
- Fits in cable management troughs. See page 577.
- 4 outlets on side create easy access.

HPWRMOD2

1.5 \$

0.2

\$401

NOTES: Power Modules will also work with standing-height applications for 10500 Series™ and Voi® desks. Mounting Clearance: 5.025" x 4.875" x 1.375". For additional information see the Workplace Tools section in the 2021 Shared Spaces Pricer.

! Black finish only, no specification needed.

HOW TO SPECIFY

Select Model Number

Select Finish Color

STRM Storm
SNW Snow
LOFT Loft

Specify Loft finish for HCOMDOME2 only

H M P P P 1 2 5 .

S T R M



EMPOWER® Voi® Laminate Low Credenzas

	DESCRIPTION	MODEL	SHIP WEIGHT	CUBE	L1 LIST	L2 UPCHARGES				
						CHASSIS	FRONTS			
	Low Credenza, 2 File/2 Box 72"W x 20"D x 21½"H 60"W x 20"D x 21½"H	HLSL2072LD4	230	21.9	\$1645	\$40	\$40			
	NOTES: Unit is locking.	HLSL2060LD4	190	18.9	\$1500	\$35	\$40			
	Low Credenza, 2 File Drawers, Open Top 72"W x 20"D x 21½"H 60"W x 20"D x 21½"H	HLSL2072LD2	200	21.9	\$1538	\$40	\$30			
	NOTES: Unit is non-locking.	HLSL2060LD2	160	18.9	\$1405	\$35	\$30			
	Low Credenza, Left Hand Drawers 72"W x 20"D x 21½"H 60"W x 20"D x 21½"H	HLSL2072LL2	200	21.9	\$1523	\$40	\$20			
	NOTES: Unit is locking.	HLSL2060LL2	160	18.9	\$1286	\$35	\$20			
	Low Credenza, Right Hand Drawers 72"W x 20"D x 21½"H 60"W x 20"D x 21½"H	HLSL2072LR2	200	21.9	\$1523	\$40	\$20			
	NOTES: Unit is locking.	HLSL2060LR2	160	18.9	\$1286	\$35	\$20			
	Low Credenza, Open 72"W x 20"D x 21½"H 60"W x 20"D x 21½"H	HLSL2072LDO	170	21.9	\$1294	\$40	N/A			
	SPECIFYING EXAMPLE: HLSL2072LDO.Z (model.chassis only)	HLSL2060LDO	130	18.9	\$1075	\$35	N/A			
	Low Credenza, 4 Storage Doors 72"W x 20"D x 21½"H 60"W x 20"D x 21½"H	HLSL2072S4	190	21.9	\$1632	\$40	\$40			
	NOTES: Unit is locking.	HLSL2060S4	160	18.9	\$1402	\$35	\$40			
	Credenza Cushion 20"W x 36"D x 1"H for 72" Credenzas 20"W x 30"D x 1"H for 60" Credenzas	HLSL2036CH2	11	2.2	\$410	\$448	\$486	\$525	\$574	\$624
	NOTES: See pages 476-477 for available fabrics. SPECIFYING EXAMPLE: HLSL2036CH2.APN23	HLSL2030CH2	9	1.9	\$380	\$416	\$452	\$488	\$534	\$581

NOTES:

- Chassis and drawer fronts woodgrains and solid laminates are specified separately (see SIF options below).
- File drawers accept hanging folders in letter size.
- Multiple handle locations possible per customer preference.
- Seat cushions are available for low credenzas and mobile pedestals (specify separately).
- Storage accessory model HLSLDRWORG works with box doors.
- Adjustable hex leveling glides allow floor-standing furniture to be easily leveled without lifting the unit; glides have 1/4" adjustable range.
- Ships with one handle per drawer on all units.
- ! Locking units equipped with HON "One Key" interchangeable core removable locks. Keyed alike core must be ordered separately.

HOW TO SPECIFY

<p>Select Model Number</p> <p>HLSL2072LD4</p>	<p>Select Chassis Laminate</p> <p>See page 173</p> <p>N</p>	<p>Select Drawer Front Laminate</p> <p>See page 173</p> <p>N</p>	<p>Select Pull Color</p> <p>See page 173</p> <p>Not specified for Open Credenza models HLSL2072LDO, HLSL2060LDO</p> <p>T4</p>
--	--	---	--

EMPOWER[®] Voi[®] Laminate Low Credenzas

GSA SIN 33721



Icon Legend on page 19

WORKSTATIONS

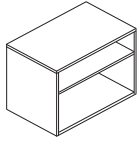

DESCRIPTION

Low Credenza — Open
30"W x 20"D x 21½"H
36"W x 20"D x 21½"H

MODEL

HLSL2030LDO
HLSL2036LDO

SHIP WEIGHT

65
85

CUBE

9.8
12.0

L1 LIST

\$889
\$916

L2 UPCHARGES

CHASSIS

\$25
\$30

FRONTS

N/A
N/A

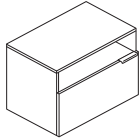

Low Credenza — Open Top, File Drawer
30"W x 20"D x 21½"H
36"W x 20"D x 21½"H

HLSL2030LD1
HLSL2036LD1

75
95

9.8
12.0

\$988
\$1018

\$25
\$30

\$15
\$15

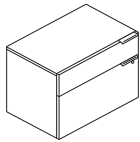

Low Credenza — 1 File Drawer, 1 Box Drawer
30"W x 20"D x 21½"H
36"W x 20"D x 21½"H

HLSL2030LD2
HLSL2036LD2

80
100

9.8
12.0

\$1098
\$1130

\$25
\$30

\$20
\$20

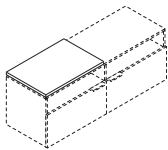

DESCRIPTION

Credenza Cushion
20"W x 36"D x 1"H for 72" Credenzas
20"W x 30"D x 1"H for 60" Credenzas

MODEL

HLSL2036CH2
HLSL2030CH2

SHIP WEIGHT

11
9

CUBE

2.2
1.9

1 2 3 4 5 6

\$410 **\$448** **\$486** **\$525** **\$574** **\$624**
\$380 **\$416** **\$452** **\$488** **\$534** **\$581**

NOTES: See pages 476-477 for available fabrics.

! For model HLSL2030CH2 must order two cushions to cover entire 60" Credenza surface.

SPECIFYING EXAMPLE: HLSL2036CH2.APN23

NOTES:

- File drawers accept hanging folders in letter size.
- Multiple handle locations possible per customer preference.
- Seat cushions are available for low credenzas and mobile pedestals (specify separately).
- Storage accessory model HLSLDRWORG works with box doors.
- Utilize in small footprint applications.
- Adjustable hex leveling glides allow floor-standing furniture to be easily leveled without lifting the unit; glides have 1¼" adjustable range.
- Ships with one handle per drawer on all units.

! Locking units equipped with HON "One Key" interchangeable core removable locks. Keyed alike core must be ordered separately.

HOW TO SPECIFY

<p>Select Model Number</p> <p>See page 173</p> <p>H L S L 2 0 3 0 L D O .</p>	<p>Select Chassis Laminate</p> <p>See page 173</p> <p>N .</p>	<p>Select Drawer Front Laminate</p> <p>See page 173</p> <p>Not specified for Open Credenza models HLSL2030LDO, HLSL2036LDO</p> <p>N .</p>	<p>Select Pull Color</p> <p>See page 173</p> <p>Not specified for Open Credenza models HLSL2030LDO, HLSL2036LDO</p> <p>T 4</p>
--	--	--	---



EMPOWER[®] Voi[®] Laminate Mobile Storage

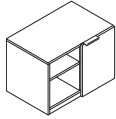

DESCRIPTION

Mobile Credenza
30"W x 20"D x 21½"H
NOTES: Unit is non-locking.

MODEL	SHIP WEIGHT	CUBE	L1 LIST	L2 UPCHARGES	
				CHASSIS	FRONTS
HLSL2030MCO	80	9.8	\$1427	\$25	\$10

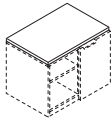

DESCRIPTION

Credenza Cushion
20"W x 30"D x 1"H for 60" Credenzas
NOTES: See pages 476-477 for available fabrics.
SPECIFYING EXAMPLE: HLSL2030CH2.APN23

MODEL	SHIP WEIGHT	CUBE	1	2	3	4	5	6
HLSL2030CH2	9	1.9	\$380	\$416	\$452	\$488	\$534	\$581

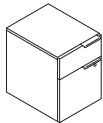

DESCRIPTION

Mobile Pedestal
15¾"W x 20⅞"D x 21⅞"H
NOTES: Unit is locking.

MODEL	SHIP WEIGHT	CUBE	L1 LIST	L2 UPCHARGES	
				CHASSIS	FRONTS
HLSL2016MP2	65	5.7	\$813	\$20	\$10

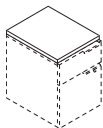

DESCRIPTION

Mobile Pedestal Cushion
15⅞"W x 20"D x 1"H for Pedestals
NOTES: See pages 476-477 for available fabrics.
SPECIFYING EXAMPLE: HLSL2016PH2.APN23

MODEL	SHIP WEIGHT	CUBE	1	2	3	4	5	6
HLSL2016PH2	6	1.1	\$315	\$339	\$363	\$387	\$418	\$449

NOTES:

- Chassis and drawer fronts woodgrains and solid laminates are specified separately (see SIF options below).
- File drawers accept hanging folders in letter or legal size.
- Multiple handle locations possible per customer preference.
- Seat cushions are available for low credenzas, floor credenzas, and mobile pedestals (specify separately). See pages 521-523 for Pedestal and Credenza cushion models.
- Storage accessory model HSLDRWORG works with box doors.
- Standard box drawers operate on ball-bearing suspension with 70% extension. File drawers operate on ball-bearing suspension with 70% extension.
- Ships with one handle per drawer on all units.

! Locking units equipped with HON "One Key" interchangeable core removable locks. Keyed alike core must be ordered separately.

HOW TO SPECIFY

<p>Select Model Number</p> <p>HLSL2030MCO . N .</p>	<p>Select Chassis Laminate</p> <p>See page 478</p> <p>N .</p>	<p>Select Drawer Front Laminate</p> <p>See page 478</p> <p>N .</p>	<p>Select Pull Color</p> <p>P Black T4 Champagne T1 Platinum PJW Designer White PR6 Silver PBX Solar Black</p> <p>T4</p>
--	--	---	---

EMPOWER® Voi® Laminate Storage Towers

GSA SIN 33721



Icon Legend on page 19

WORKSTATIONS

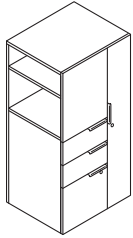

DESCRIPTION	MODEL	SHIP WEIGHT	CUBE	L1 LIST	L2 UPCHARGES	
					CHASSIS	FRONTS
24"W x 20"D Storage Tower — Right Hand Drawers, Left Hand Door						
24"W x 20"D x 50"H, Left	HLSLW045L	167	17.4	\$1967	\$50	\$35
24"W x 20"D x 65"H, Left	HLSLW046L	200	22.5	\$2231	\$55	\$35
24"W x 20"D Storage Tower — Left Hand Drawers, Right Hand Door						
24"W x 20"D x 50"H, Right	HLSLW045R	167	17.4	\$1967	\$50	\$35
24"W x 20"D x 65"H, Right	HLSLW046R	200	22.5	\$2231	\$55	\$35

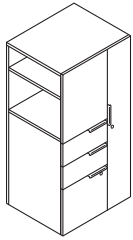

24"W x 24"D Storage Tower — Right Hand Drawers, Left Hand Door						
24"W x 24"D x 50"H, Left	HLSLW445L	200	20.7	\$2131	\$55	\$35
24"W x 24"D x 65"H, Left	HLSLW446L	240	27.8	\$2349	\$60	\$35
24"W x 24"D Storage Tower — Left Hand Drawers, Right Hand Door						
24"W x 24"D x 50"H, Right	HLSLW445R	200	20.7	\$2131	\$55	\$35
24"W x 24"D x 65"H, Right	HLSLW446R	240	27.8	\$2349	\$60	\$35

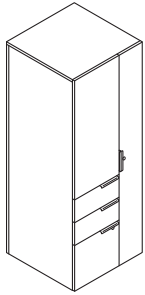

24"W x 24"D Personal Storage Tower						
24"W x 24"D x 65"H, Left	HLSLW446LP	250	27.8	\$2660	\$60	\$35
24"W x 24"D x 65"H, Right	HLSLW446RP	250	27.8	\$2660	\$60	\$35

NOTES:

- Chassis and drawer fronts woodgrains and solid laminates are specified separately (see SIF options below).
- File drawers accept hanging folders in letter or legal size.
- Wardrobe, middle box drawer and file drawer are locking.
- Standard box drawers operate on ball-bearing suspension with full extension. File, lateral, and wide box drawers operate on ball-bearing suspension with full extension.
- Ships with one handle per drawer on all units.
- Adjustable hex leveling glides allow floor-standing furniture to be easily leveled without lifting the unit; glides have 1/4" adjustable range.
- Wardrobe/storage cabinet includes coat rod.
- Wardrobes contain easy access side storage shelves.

ⓘ Locking units equipped with HON "One Key" interchangeable core removable locks. Keyed alike core must be ordered separately.

HOW TO SPECIFY

<p>Select Model Number</p> <p>H L S L W 0 4 5 L .</p>	<p>Select Chassis Laminate</p> <p>See page 173</p> <p>N .</p>	<p>Select Drawer Front Laminate</p> <p>See page 173</p> <p>N .</p>	<p>Select Pull Color</p> <p>See page 173</p> <p>T 4</p>
--	--	---	--



Icon Legend on page 19

EMPOWER[®] Voi[®] Laminate Storage Towers

WORKSTATIONS

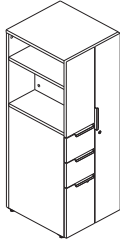

DESCRIPTION

18''W x 20''D Storage Towers — Right Hand Drawers, Left Hand Door

	MODEL	SHIP WEIGHT	CUBE	L1 LIST	L2 UPCHARGES CHASSIS	FRONTS
18''W x 20''D x 50''H, Left	HLSLW085L	139	13.4	\$1771	\$45	\$35
18''W x 20''D x 65''H, Left	HLSLW086L	167	17.3	\$2012	\$50	\$35

18''W x 20''D Storage Towers — Left Hand Drawers, Right Hand Door

18''W x 20''D x 50''H, Right	HLSLW085R	139	13.4	\$1771	\$45	\$35
18''W x 20''D x 65''H, Right	HLSLW086R	167	17.3	\$2012	\$50	\$35

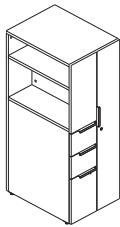

18''W x 24''D Storage Towers — Right Hand Drawers, Left Hand Door

18''W x 24''D x 50''H, Left	HLSLW485L	167	15.8	\$2015	\$50	\$35
18''W x 24''D x 65''H, Left	HLSLW486L	200	21.5	\$2234	\$55	\$35

18''W x 24''D Storage Towers — Left Hand Drawers, Right Hand Door

18''W x 24''D x 50''H, Right	HLSLW485R	167	15.8	\$2015	\$50	\$35
18''W x 24''D x 65''H, Right	HLSLW486R	200	21.5	\$2234	\$55	\$35

NOTES:

- Ships with one handle per drawer on all units.
- Chassis and drawer fronts woodgrains and solid laminates are specified separately (see SIF options below).
- File drawers accept hanging folders in letter or legal size.
- Standard box drawers operate on ball-bearing suspension with full extension. File and box drawers operate on ball-bearing suspension with full extension.
- Adjustable hex leveling glides allow floor-standing furniture to be easily leveled without lifting the unit; glides have 1/4" adjustable range.
- Wardrobe/storage cabinet includes coat rod.
- Wardrobes contain easy access side storage shelves.
- Wardrobe, middle box drawer and file drawer are locking.

! Locking units equipped with HON "One Key" interchangeable core removable locks. Keyed alike core must be ordered separately.

HOW TO SPECIFY

<p>Select Model Number</p> <p>HL SLW085L</p>	<p>Select Chassis Laminate</p> <p>See page 173</p> <p>N</p>	<p>Select Door/Drawer Front Laminate</p> <p>See page 173</p> <p>N</p>	<p>Select Pull Color</p> <p>See page 173</p> <p>T4</p>
---	--	--	---

EMPOWER® Contain® Metal Credenzas

GSA SIN 33721



Icon Legend on page 19

WORKSTATIONS

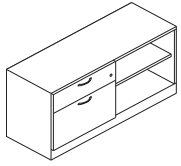

DESCRIPTION

Low Credenza, Box/Lateral Left, Open Shelf Right
72"W x 18"D x 22"H
60"W x 18"D x 22"H
48"W x 18"D x 22"H

MODEL

HSCP227218RBFOM
HSCP226018RBFOM
HSCP224818RBFOM

SHIP WEIGHT

150
130
111

CUBE

20.7
17.3
14.0

LIST PRICE BY PAINT GRADE

P1	P2	P3
\$1946	\$2013	\$2081
\$1755	\$1822	\$1890
\$1618	\$1685	\$1753

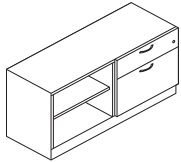

Low Credenza, Box/Lateral Right, Open Shelf Left
72"W x 18"D x 22"H
60"W x 18"D x 22"H
48"W x 18"D x 22"H

HSCP227218LBFOM
HSCP226018LBFOM
HSCP224818LBFOM

150
130
111

20.7
17.3
14.0

P1	P2	P3
\$1946	\$2013	\$2081
\$1755	\$1822	\$1890
\$1618	\$1685	\$1753

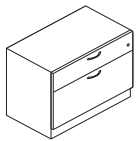

Low Credenza, Box/Lateral
36"W x 18"D x 22"H
30"W x 18"D x 22"H

HSCP223618BFM
HSCP223018BFM

87
76

10.6
9.0

P1	P2	P3
\$1190	\$1223	\$1258
\$1140	\$1173	\$1208

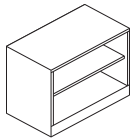

Open Shelf
36"W x 18"D x 22"H
30"W x 18"D x 22"H

HSCP223618O
HSCP223018O

66
60

10.6
9.0

P1	P2	P3
\$847	\$880	\$915
\$781	\$814	\$849

NOTES:

- Metal chassis and drawer fronts.
- Lateral and wide box drawers operate on ball-bearing suspension with full extension.
- Steel ball-bearing drawer suspensions.
- Ships complete with standard kickplate.
- Field installable counterweight sold separately.
- File drawers accept hanging folders in letter or legal size.
- Steel frame provides durability.
- Use with laminate tops and credenza seat cushions. Order separately — see pages 649-650.

⚠ Locking units equipped with HON "One Key" interchangeable core removable locks. Keyed alike core model HF23S, in Satin, must be ordered separately. See page 649.

HOW TO SPECIFY



<p>Select Model Number</p> <p>H S C P 2 2 3 6 1 8 O .</p>	<p>Select Base</p> <p>BK Flush Plinth BX Recessed Plinth</p> <p>B K .</p>	<p>Select Case Paint</p> <p>See page 640</p> <p>P J W .</p>	<p>Select Shelf Paint</p> <p>See page 640</p> <p>P J W .</p>
--	--	--	---

<p>Select Model Number</p> <p>H S C P 2 2 7 2 1 8 R B F O M .</p>	<p>Select Base</p> <p>BK Flush Plinth BX Recessed Plinth</p> <p>B K .</p>	<p>Select Pull</p> <p>A Arch PRO Silver R Radius N Integral S Square PR6 Silver</p> <p>A P R O .</p>	<p>Select Case Paint</p> <p>See page 640</p> <p>P J W .</p>	<p>Select Front Paint</p> <p>NA Matches Case</p> <p>N A .</p>	<p>Select Shelf Paint</p> <p>See page 640 Not specified for models HSCP223018BFM and HSCP223618BFM</p> <p>P J W .</p>	<p>Select Lock</p> <p>L Standard Lock X Omit Lock (- \$20) Not specified for models HSCP223618O and HSCP223018O</p> <p>L .</p>
--	--	---	--	--	--	---

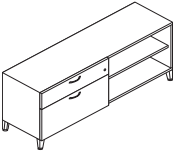
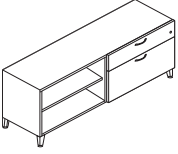

Icon Legend on page 19

EMPOWER® Contain® Footed Metal Credenzas

	DESCRIPTION	MODEL	SHIP WEIGHT	CUBE	LIST PRICE BY PAINT GRADE		
					P1	P2	P3
	Footed Low Credenza, Box/Lateral Left, Open Shelf Right						
	72"W x 18"D x 22"H	HSCF227218RBFOM	150	17.7	\$2102	\$2169	\$2237
	60"W x 18"D x 22"H	HSCF226018RBFOM	130	14.9	\$1913	\$1980	\$2048
	48"W x 18"D x 22"H	HSCF224818RBFOM	111	12.0	\$1745	\$1812	\$1880
	Footed Low Credenza, Box/Lateral Right, Open Shelf Left						
	72"W x 18"D x 22"H	HSCF227218LBFOM	150	17.7	\$2102	\$2169	\$2237
	60"W x 18"D x 22"H	HSCF226018LBFOM	130	14.9	\$1913	\$1980	\$2048
	48"W x 18"D x 22"H	HSCF224818LBFOM	111	12.0	\$1745	\$1812	\$1880
	Footed Low Credenza, Box/Lateral						
	36"W x 18"D x 22"H	HSCF223618BFM	87	9.1	\$1316	\$1349	\$1384
	30"W x 18"D x 22"H	HSCF223018BFM	76	7.7	\$1265	\$1298	\$1333
	Footed Open Shelf						
	36"W x 18"D x 22"H	HSCF223618O	66	9.1	\$974	\$1007	\$1042
	30"W x 18"D x 22"H	HSCF223018O	60	7.7	\$907	\$940	\$975

NOTES:

- Lateral and wide box drawers operate on ball-bearing suspension with full extension.
- Steel ball-bearing drawer suspensions.
- Ships complete with standard footed base.
- Field installable counterweight sold separately.
- File drawers accept hanging folders in letter or legal size.
- Steel frame provides durability.
- Feet are shipped with the credenza unit and are easily assembled.
- Use with laminate tops and credenza seat cushions. Order separately — see pages 649-650.

🔑 Locking units equipped with HON "One Key" interchangeable core removable locks. Keyed alike core model HF23S, in Satin, must be ordered separately. See page 649.

HOW TO SPECIFY

<p>Select Model Number</p> <p>HSCF223618O</p>	<p>Select Foot</p> <p>SF Contain Foot T1 Platinum Metallic PR6 Silver</p> <p>SFT1</p>	<p>Select Case Paint</p> <p>See page 640</p> <p>PJW</p>	<p>Select Shelf Paint</p> <p>See page 640</p> <p>PJW</p>
--	--	--	---

<p>Select Model Number</p> <p>HSCF227218RBFOM</p>	<p>Select Foot</p> <p>SF Contain Foot T1 Platinum Metallic PR6 Silver</p> <p>SFT1</p>	<p>Select Pull</p> <p>A Arch PRO Silver R Radius N Integral S Square PR6 Silver</p> <p>APRO</p>	<p>Select Case Paint</p> <p>See page 640</p> <p>PJW</p>	<p>Select Front Paint</p> <p>NA Matches Case</p> <p>NA</p>	<p>Select Shelf Paint</p> <p>See page 640 Not specified for models HSCF223618BFM and HSCF223018BFM</p> <p>PJW</p>	<p>Select Lock</p> <p>L Standard Lock X Omit Lock (- \$20) Not specified for models HSCF223618O and HSCF223018O</p> <p>L</p>
--	--	--	--	---	--	---

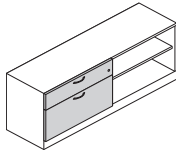
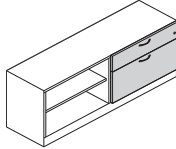
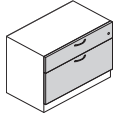

Icon Legend on page 19

	DESCRIPTION	MODEL	SHIP WEIGHT	CUBE	LIST PRICE BY PAINT GRADE		
					P1	P2	P3
	Metal Low Credenza, Laminate Front, Box/Lateral Left, Open Shelf Right						
	72"W x 18"D x 22"H	HSCP227218RBFOL	152	20.7	\$2158	\$2225	\$2293
	60"W x 18"D x 22"H	HSCP226018RBFOL	132	17.3	\$1968	\$2035	\$2103
	48"W x 18"D x 22"H	HSCP224818RBFOL	113	14.0	\$1831	\$1898	\$1966
	Metal Low Credenza, Laminate Front, Box/Lateral Right, Open Shelf Left						
	72"W x 18"D x 22"H	HSCP227218LBFOL	152	20.7	\$2158	\$2225	\$2293
	60"W x 18"D x 22"H	HSCP226018LBFOL	132	17.3	\$1968	\$2035	\$2103
	48"W x 18"D x 22"H	HSCP224818LBFOL	113	14.0	\$1831	\$1898	\$1966
	Metal Low Credenza, Laminate Front Box/Lateral						
	36"W x 18"D x 22"H	HSCP223618BFL	89	10.6	\$1403	\$1436	\$1471
	30"W x 18"D x 22"H	HSCP223018BFL	76	9.0	\$1352	\$1385	\$1420

NOTES:

- Lateral and wide box drawers operate on ball-bearing suspension with full extension.
- Steel ball-bearing drawer suspensions.
- Ships complete with standard kickplate.
- Field installable counterweight sold separately.
- File drawers accept hanging folders in letter or legal size.
- Steel frame provides durability.
- Use with laminate tops and credenza seat cushions. Order separately — see pages 649-650.

ⓘ Locking units equipped with HON "One Key" interchangeable core removable locks. Keyed alike core model HF23S, in Satin, must be ordered separately. See page 649.

HOW TO SPECIFY

Select Model Number	Select Base	Select Pull	Select Case Paint	Select Laminate	Select Shelf Paint	Select Lock
	BX Recessed Plinth	A Arch PRO Silver S Square PR6 Silver	See page 640	See page 640	See page 640 Not specified for models HSCP223618BFL and HSCP223018BFL	L Standard Lock X Omit Lock (- \$20)
H S C P 2 2 7 2 1 8 R B F O L .	B X .	A P R O .	P J W .	L S A 1 .	P J W .	L



Icon Legend on page 19

Contain® Footed Metal Credenzas with Laminate Fronts

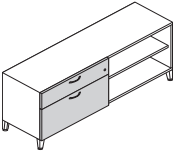
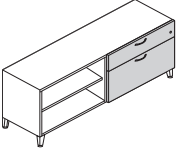
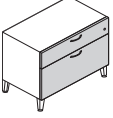
	DESCRIPTION	MODEL	SHIP WEIGHT	CUBE	LIST PRICE BY PAINT GRADE		
					P1	P2	P3
	Footed Low Credenza, Laminated Front, Box/Lateral Left, Open Shelf Right						
	72"W x 18"D x 22"H	HSCF227218RBFOL	152	17.7	\$2316	\$2383	\$2451
	60"W x 18"D x 22"H	HSCF226018RBFOL	132	14.9	\$2124	\$2191	\$2259
	48"W x 18"D x 22"H	HSCF224818RBFOL	113	12.0	\$1957	\$2024	\$2092
	Footed Low Credenza, Laminated Front, Box/Lateral Right, Open Shelf Left						
	72"W x 18"D x 22"H	HSCF227218LBFOL	152	17.7	\$2316	\$2383	\$2451
	60"W x 18"D x 22"H	HSCF226018LBFOL	132	14.9	\$2124	\$2191	\$2259
	48"W x 18"D x 22"H	HSCF224818LBFOL	113	12.0	\$1957	\$2024	\$2092
	Footed Low Credenza, Laminated Front Box/Lateral						
	36"W x 18"D x 22"H	HSCF223618BFL	89	9.1	\$1528	\$1561	\$1596
	30"W x 18"D x 22"H	HSCF223018BFL	78	7.7	\$1479	\$1512	\$1547

NOTES:

- Lateral and wide box drawers operate on ball-bearing suspension with full extension.
- Steel ball-bearing drawer suspensions.
- Ships complete with standard footed base.
- Field installable counterweight sold separately.
- File drawers accept hanging folders in letter or legal size.
- Steel frame provides durability.
- Feet are shipped with the credenza unit and are easily assembled.
- Use with laminate tops and credenza seat cushions. Order separately — see pages 649-650.

! Locking units equipped with HON "One Key" interchangeable core removable locks. Keyed alike core model HF23S, in Satin, must be ordered separately. See page 649.

HOW TO SPECIFY

Select Model Number H S C F 2 2 7 2 1 8 R B F O L	Select Foot SF Contain Foot T1 Platinum Metallic PR6 Silver	Select Pull A Arch PRO Silver S Square PR6 Silver	Select Case Paint See page 640 P J W	Select Laminate See page 640 L S A 1	Select Shelf Paint See page 640 Not specified for models HSCF223618BFL and HSCF223018BFL P J W	Select Lock L Standard Lock X Omit Lock (- \$20) L
---	--	--	---	---	--	--

EMPOWER® Contain® Metal Credenzas Accessories

GSA SIN 33721



Icon Legend on page 19

WORKSTATIONS

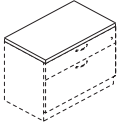

DESCRIPTION	MODEL	SHIP WEIGHT CUBE													
		1	2	3	4	5	6	7	8	9	10	11	12		
Credenza Cushion 36"W x 18"D for 36", 60", and 72" Credenzas	HSCAUC1836	16.3	1.6	\$282	\$320	\$358	\$397	\$446	\$496	\$546	\$595	\$645	\$694	\$744	\$794
30"W x 18"D for 30", 48", and 60" Credenzas	HSCAUC1830	16.3	1.6	\$263	\$301	\$339	\$378	\$427	\$477	\$527	\$576	\$626	\$675	\$725	\$775
24"W x 18"D for 48" Credenzas	HSCAUC1824	16.3	1.9	\$246	\$284	\$322	\$361	\$410	\$460	\$510	\$559	\$609	\$658	\$708	\$758

NOTES: See pages 22-24 for available fabrics.
SPECIFYING EXAMPLE: HSCAUC1836.APN23

NOTES:

- For matching Pedestal Seats, see page 674.
- Credenza Cushions are available in 24", 30" and 36" size options.
- Choose from multiple upholstery options, see pages 22-24.

HOW TO SPECIFY

Select Model Number	Select Fabric
	See pages 22-24
H S C A U C 1 8 3 6 .	A B 1 0

	DESCRIPTION	MODEL	SHIP WEIGHT	CUBE	LIST PRICE
					P1
	Metal Box Divider 10 pack	HSCABD10	7	0.7	\$170
	2 pack	HSCABD02	2	0.7	\$43
! Metal dividers available in Black only. No need to specify.					
	Metal File Divider 10 pack	HSCAFD10	12	0.7	\$202
	2 pack	HSCAFD02	3	0.7	\$53
! Metal dividers available in Black only. No need to specify.					



Icon Legend on page 19

EMPOWER® Contain® Metal Personal Towers

	DESCRIPTION	MODEL	SHIP WEIGHT	CUBE	LIST PRICE BY PAINT GRADE		
					P1	P2	P3
	Personal Tower with Metal Fronts, Door/Box/Box/File						
	65"H x 24"W x 24"D, Wardrobe Left	HSTP652424LBBFM	178	27.2	\$2046	\$2123	\$2191
	65"H x 24"W x 24"D, Wardrobe Right	HSTP652424RBBFM	178	27.2	\$2046	\$2123	\$2191
	50"H x 24"W x 24"D, Wardrobe Left	HSTP502424LBBFM	146	21.2	\$1915	\$1992	\$2060
	50"H x 24"W x 24"D, Wardrobe Right	HSTP502424RBBFM	146	21.2	\$1915	\$1992	\$2060
	42"H x 24"W x 24"D, Wardrobe Left	HSTP422424LBBFM	132	16.8	\$1645	\$1695	\$1770
	42"H x 24"W x 24"D, Wardrobe Right	HSTP422424RBBFM	132	16.8	\$1645	\$1695	\$1770
	Personal Tower with Metal Fronts, Door/File/File						
	65"H x 24"W x 24"D, Wardrobe Left	HSTP652424LFFM	178	27.2	\$1995	\$2072	\$2140
	65"H x 24"W x 24"D, Wardrobe Right	HSTP652424RFFM	178	27.2	\$1995	\$2072	\$2140
	50"H x 24"W x 24"D, Wardrobe Left	HSTP502424LFFM	146	21.1	\$1865	\$1942	\$2010
	50"H x 24"W x 24"D, Wardrobe Right	HSTP502424RFFM	146	21.1	\$1865	\$1942	\$2010
	42"H x 24"W x 24"D, Wardrobe Left	HSTP422424LFFM	132	16.8	\$1594	\$1644	\$1719
	42"H x 24"W x 24"D, Wardrobe Right	HSTP422424RFFM	132	16.8	\$1594	\$1644	\$1719

NOTES:

- Metal chassis and drawer fronts.
- Steel frame provides durability.
- Leveling glides can be adjusted from outside or inside the case.
- Heavy-duty, telescoping ball-bearing slides.
- Baked, epoxy/polyester, powder coating finish.
- One lock secures doors and drawers.
- Pencil tray standard in top box drawer.
- One box divider standard in each box drawer.
- One crossrail standard in each file drawer.

! Locking units equipped with HON "One Key" interchangeable core removable locks. Keyed alike core model HF23S, in Satin, must be ordered separately. See page 649.

HOW TO SPECIFY

Select Model Number	Select Base	Select Pull	Select Case Paint	Select Front Paint	Select Lock
	BK Flush Plinth BX Recessed Plinth	A Arch PRO Silver R Radius N Integral S Square PR6 Silver	See page 640	NA Matches Case	L Standard Lock X Omit Lock (- \$20)
H S T P 6 5 2 4 2 4 L F F M .	B X .	S P R 6 .	P 7 T .	N A .	L

EMPOWER® Contain® Metal Side Access Towers

GSA SIN 33721



Icon Legend on page 19

WORKSTATIONS

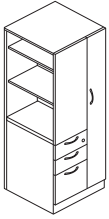

DESCRIPTION	MODEL	SHIP WEIGHT	CUBE	LIST PRICE BY PAINT GRADE		
				P1	P2	P3
Side Access Tower with Metal Fronts, Shelves/Box/Box/File						
65"H x 24"W x 24"D, Wardrobe Left	HSTSP652424LBBFM	178	27.2	\$2167	\$2244	\$2312
65"H x 24"W x 24"D, Wardrobe Right	HSTSP652424RBBFM	178	27.2	\$2167	\$2244	\$2312
50"H x 24"W x 24"D, Wardrobe Left	HSTSP502424LBBFM	146	21.2	\$2029	\$2106	\$2174
50"H x 24"W x 24"D, Wardrobe Right	HSTSP502424RBBFM	146	21.2	\$2029	\$2106	\$2174
42"H x 24"W x 24"D, Wardrobe Left	HSTSP422424LBBFM	132	16.8	\$1831	\$1881	\$1956
42"H x 24"W x 24"D, Wardrobe Right	HSTSP422424RBBFM	132	16.8	\$1831	\$1881	\$1956

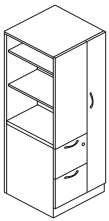

Side Access Tower with Metal Fronts, Shelves/File/File						
65"H x 24"W x 24"D, Wardrobe Left	HSTSP652424LFFM	178	27.2	\$2117	\$2194	\$2262
65"H x 24"W x 24"D, Wardrobe Right	HSTSP652424RFFM	178	27.2	\$2117	\$2194	\$2262
50"H x 24"W x 24"D, Wardrobe Left	HSTSP502424LFFM	146	21.2	\$1978	\$2055	\$2123
50"H x 24"W x 24"D, Wardrobe Right	HSTSP502424RFFM	146	21.2	\$1978	\$2055	\$2123
42"H x 24"W x 24"D, Wardrobe Left	HSTSP422424LFFM	132	16.8	\$1780	\$1830	\$1905
42"H x 24"W x 24"D, Wardrobe Right	HSTSP422424RFFM	132	16.8	\$1780	\$1830	\$1905

NOTES:

- Towers can be used to support a worksurface. In order to do so, order bracket model HSTB2W1.
- Metal chassis and drawer fronts.
- Steel frame provides durability.
- Leveling glides can be adjusted from outside or inside the case.
- Heavy-duty, telescoping ball-bearing slides.
- Baked, epoxy/polyester, powder coating finish.
- One lock secures doors and drawers.
- Pencil tray standard in top box drawer.
- One box divider standard in each box drawer.
- One crossrail standard in each file drawer.

! Locking units equipped with HON "One Key" interchangeable core removable locks. Keyed alike core model HF23S, in Satin, must be ordered separately. See page 649.

HOW TO SPECIFY

<p>Select Model Number</p> <p>H S T S P 6 5 2 4 2 4 L F F M .</p>	<p>Select Base</p> <p>BK Flush Plinth BX Recessed Plinth</p> <p>B X .</p>	<p>Select Pull</p> <p>A Arch PRO Silver R Radius N Integral S Square PR6 Silver</p> <p>S P R 6 .</p>	<p>Select Case Paint</p> <p>See page 640</p> <p>P 7 T .</p>	<p>Select Front Paint</p> <p>NA Matches Case</p> <p>N A .</p>	<p>Select Panel Paint</p> <p>NA Matches Case</p> <p>N A .</p>	<p>Select Lock</p> <p>L Standard X Lock Omit Lock (- \$20)</p> <p>L</p>
--	--	---	--	--	--	--



Icon Legend on page 19

Contain® Metal Personal Towers with Laminate Fronts

	DESCRIPTION	MODEL	SHIP WEIGHT	CUBE	LIST PRICE BY PAINT GRADE		
					P1	P2	P3
	Personal Tower with Laminate Fronts, Door/Box/Box/File						
	65”H x 24”W x 24”D, Wardrobe Left	HSTP652424LBBFL	178	27.2	\$2344	\$2421	\$2489
	65”H x 24”W x 24”D, Wardrobe Right	HSTP652424RBBFL	178	27.2	\$2344	\$2421	\$2489
	50”H x 24”W x 24”D, Wardrobe Left	HSTP502424LBBFL	146	21.2	\$2195	\$2272	\$2340
	50”H x 24”W x 24”D, Wardrobe Right	HSTP502424RBBFL	146	21.2	\$2195	\$2272	\$2340
	42”H x 24”W x 24”D, Wardrobe Left	HSTP422424LBBFL	132	16.8	\$1884	\$1934	\$2009
	42”H x 24”W x 24”D, Wardrobe Right	HSTP422424RBBFL	132	16.8	\$1884	\$1934	\$2009
	Personal Tower with Laminate Fronts, Door/File/File						
	65”H x 24”W x 24”D, Wardrobe Left	HSTP652424LFFL	178	27.2	\$2294	\$2371	\$2439
	65”H x 24”W x 24”D, Wardrobe Right	HSTP652424RFFL	178	27.2	\$2294	\$2371	\$2439
	50”H x 24”W x 24”D, Wardrobe Left	HSTP502424LFFL	146	21.2	\$2144	\$2221	\$2289
	50”H x 24”W x 24”D, Wardrobe Right	HSTP502424RFFL	146	21.2	\$2144	\$2221	\$2289
	42”H x 24”W x 24”D, Wardrobe Left	HSTP422424LFFL	132	16.8	\$1833	\$1883	\$1958
	42”H x 24”W x 24”D, Wardrobe Right	HSTP422424RFFL	132	16.8	\$1833	\$1883	\$1958

NOTES:

- Metal chassis with laminate drawer/door fronts.
- Steel frame provides durability.
- Leveling glides can be adjusted from outside or inside the case.
- Heavy-duty, telescoping ball-bearing slides.
- Baked, epoxy/polyester, powder coating finish.
- One lock secures doors and drawers.
- Pencil tray standard in top box drawer.
- One box divider standard in each box drawer.
- One crossrail standard in each file drawer.

! Locking units equipped with HON “One Key” interchangeable core removable locks. Keyed alike core model HF23S, in Satin, must be ordered separately. See page 649.

HOW TO SPECIFY

Select Model Number	Select Base	Select Pull	Select Case Paint	Select Laminate	Select Lock
	BX Recessed Plinth	A Arch PRO Silver S Square PR6 Silver	See page 640	See page 640	L Standard Lock X Omit Lock (- \$20)
H S T P 6 5 2 4 2 4 L F F L .	B X .	S P R 6 .	P 7 T .	L S A 1 .	L

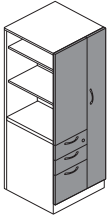

DESCRIPTION	MODEL	SHIP WEIGHT	CUBE	LIST PRICE BY PAINT GRADE		
				P1	P2	P3
Side Access Tower with Laminate Fronts, Shelves/Box/Box/File						
65"H x 24"W x 24"D, Wardrobe Left	HSTSP652424LBBFL	178	27.2	\$2484	\$2561	\$2629
65"H x 24"W x 24"D, Wardrobe Right	HSTSP652424RBBFL	178	27.2	\$2484	\$2561	\$2629
50"H x 24"W x 24"D, Wardrobe Left	HSTSP502424LBBFL	146	21.2	\$2325	\$2402	\$2470
50"H x 24"W x 24"D, Wardrobe Right	HSTSP502424RBBFL	146	21.2	\$2325	\$2402	\$2470
42"H x 24"W x 24"D, Wardrobe Left	HSTSP422424LBBFL	132	16.8	\$2097	\$2147	\$2222
42"H x 24"W x 24"D, Wardrobe Right	HSTSP422424RBBFL	132	16.8	\$2097	\$2147	\$2222

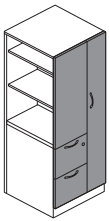

Side Access Tower with Laminate Fronts, Shelves/File/File						
65"H x 24"W x 24"D, Wardrobe Left	HSTSP652424LFFL	178	27.2	\$2434	\$2511	\$2579
65"H x 24"W x 24"D, Wardrobe Right	HSTSP652424RFFL	178	27.2	\$2434	\$2511	\$2579
50"H x 24"W x 24"D, Wardrobe Left	HSTSP502424LFFL	146	21.2	\$2275	\$2352	\$2420
50"H x 24"W x 24"D, Wardrobe Right	HSTSP502424RFFL	146	21.2	\$2275	\$2352	\$2420
42"H x 24"W x 24"D, Wardrobe Left	HSTSP422424LFFL	132	16.8	\$2047	\$2097	\$2172
42"H x 24"W x 24"D, Wardrobe Right	HSTSP422424RFFL	132	16.8	\$2047	\$2097	\$2172

NOTES:

- Towers can be used to support a worksurface. In order to do so, order bracket model HSTB2W1.
- Metal chassis with laminate drawer/door fronts.
- Steel frame provides durability.
- Leveling glides can be adjusted from outside or inside the case.
- Heavy-duty, telescoping ball-bearing slides.
- Baked, epoxy/polyester, powder coating finish.
- One lock secures doors and drawers.
- Pencil tray standard in top box drawer.
- One box divider standard in each box drawer.
- One crossrail standard in each file drawer.

⚠ Locking units equipped with HON "One Key" interchangeable core removable locks. Keyed alike core model HF23S, in Satin, must be ordered separately. See page 649.

HOW TO SPECIFY

<p>Select Model Number</p> <p>H S T S P 6 5 2 4 2 4 L F F L .</p>	<p>Select Base</p> <p>BX Recessed Plinth</p> <p>B X .</p>	<p>Select Pull</p> <p>A Arch PRO Silver S Square PR6 Silver</p> <p>S P R 6 .</p>	<p>Select Case Paint</p> <p>See page 640</p> <p>P 7 T .</p>	<p>Select Laminate</p> <p>See page 640</p> <p>L S A 1 .</p>	<p>Select Lock</p> <p>L Standard Lock X Omit Lock (- \$20)</p> <p>L</p>
--	--	---	--	--	--



Icon Legend on page 19

Contain® Footed Metal Personal Towers

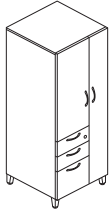

DESCRIPTION	MODEL	SHIP WEIGHT	CUBE	LIST PRICE BY PAINT GRADE		
				P1	P2	P3
Footed Personal Tower with Metal Fronts, Door/Box/Box/File						
65”H x 24”W x 24”D, Wardrobe Left	HSTF652424LBBFM	178	25.8	\$2167	\$2244	\$2312
65”H x 24”W x 24”D, Wardrobe Right	HSTF652424RBBFM	178	25.8	\$2167	\$2244	\$2312
50”H x 24”W x 24”D, Wardrobe Left	HSTF502424LBBFM	146	19.8	\$2037	\$2114	\$2182
50”H x 24”W x 24”D, Wardrobe Right	HSTF502424RBBFM	146	19.8	\$2037	\$2114	\$2182
42”H x 24”W x 24”D, Wardrobe Left	HSTF422424LBBFM	132	18.2	\$1766	\$1816	\$1891
42”H x 24”W x 24”D, Wardrobe Right	HSTF422424RBBFM	132	18.2	\$1766	\$1816	\$1891

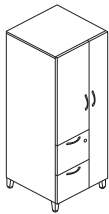

Footed Personal Tower with Metal Fronts, Door/File/File						
65”H x 24”W x 24”D, Wardrobe Left	HSTF652424LFFM	178	25.8	\$2117	\$2194	\$2262
65”H x 24”W x 24”D, Wardrobe Right	HSTF652424RFFM	178	25.8	\$2117	\$2194	\$2262
50”H x 24”W x 24”D, Wardrobe Left	HSTF502424LFFM	146	19.8	\$1986	\$2063	\$2131
50”H x 24”W x 24”D, Wardrobe Right	HSTF502424RFFM	146	19.8	\$1986	\$2063	\$2131
42”H x 24”W x 24”D, Wardrobe Left	HSTF422424LFFM	132	18.2	\$1716	\$1766	\$1841
42”H x 24”W x 24”D, Wardrobe Right	HSTF422424RFFM	132	18.2	\$1716	\$1766	\$1841

NOTES:

- Metal chassis and drawer fronts.
- Steel frame provides durability.
- Leveling glides can be adjusted from outside or inside the case.
- Heavy-duty, telescoping ball-bearing slides.
- Baked, epoxy/polyester, powder coating finish.
- One lock secures doors and drawers.
- Pencil tray standard in top box drawer.
- One box divider standard in each box drawer.
- One crossrail standard in each file drawer.

! Locking units equipped with HON “One Key” interchangeable core removable locks. Keyed alike core model HF23S, in Satin, must be ordered separately. See page 649.

HOW TO SPECIFY

<p>Select Model Number</p> <p>H S T F 4 2 2 4 2 4 L B B F M .</p>	<p>Select Foot</p> <p>SF Contain Foot T1 Platinum Metallic PR6 Silver</p> <p>S F T 1 .</p>	<p>Select Pull</p> <p>A Arch PRO Silver R Radius N Integral S Square PR6 Silver</p> <p>S P R 6 .</p>	<p>Select Paint Color</p> <p>See page 640</p> <p>P 7 T .</p>	<p>Select Front Paint</p> <p>NA Matches Case</p> <p>N A .</p>	<p>Select Lock</p> <p>L Standard Lock X Omit Lock (- \$20)</p> <p>L</p>
--	---	---	---	--	--

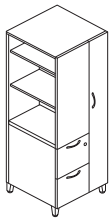
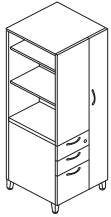

DESCRIPTION	MODEL	SHIP WEIGHT	CUBE	LIST PRICE BY PAINT GRADE		
				P1	P2	P3
Footed Side Access Tower with Metal Fronts, Shelves/Box/Box/File						
65"H x 24"W x 24"D, Wardrobe Left	HSTSF652424LBBFM	178	25.8	\$2289	\$2366	\$2434
65"H x 24"W x 24"D, Wardrobe Right	HSTSF652424RBBFM	178	25.8	\$2289	\$2366	\$2434
50"H x 24"W x 24"D, Wardrobe Left	HSTSF502424LBBFM	146	19.8	\$2150	\$2227	\$2295
50"H x 24"W x 24"D, Wardrobe Right	HSTSF502424RBBFM	146	19.8	\$2150	\$2227	\$2295
42"H x 24"W x 24"D, Wardrobe Left	HSTSF422424LBBFM	132	18.2	\$1953	\$2003	\$2078
42"H x 24"W x 24"D, Wardrobe Right	HSTSF422424RBBFM	132	18.2	\$1953	\$2003	\$2078
Footed Side Access Tower with Metal Fronts, Shelves/File/File						
65"H x 24"W x 24"D, Wardrobe Left	HSTSF652424LFFM	178	25.8	\$2238	\$2315	\$2383
65"H x 24"W x 24"D, Wardrobe Right	HSTSF652424RFFM	178	25.8	\$2238	\$2315	\$2383
50"H x 24"W x 24"D, Wardrobe Left	HSTSF502424LFFM	146	19.8	\$2099	\$2176	\$2244
50"H x 24"W x 24"D, Wardrobe Right	HSTSF502424RFFM	146	19.8	\$2099	\$2176	\$2244
42"H x 24"W x 24"D, Wardrobe Left	HSTSF422424LFFM	132	18.2	\$1902	\$1952	\$2027
42"H x 24"W x 24"D, Wardrobe Right	HSTSF422424RFFM	132	18.2	\$1902	\$1952	\$2027

NOTES:

- Towers can be used to support a worksurface. In order to do so, order bracket model HSTB2W1.
- Metal chassis and drawer fronts.
- Steel frame provides durability.
- Leveling glides can be adjusted from outside or inside the case.
- Heavy-duty, telescoping ball-bearing slides.
- Baked, epoxy/polyester, powder coating finish.
- One lock secures doors and drawers.
- Pencil tray standard in top box drawer.
- One box divider standard in each box drawer.
- One crossrail standard in each file drawer.

! Locking units equipped with HON "One Key" interchangeable core removable locks. Keyed alike core model HF23S, in Satin, must be ordered separately. See page 649.

HOW TO SPECIFY

<p>Select Model Number</p> <p>H S T S F 4 2 2 4 2 4 R B B F M</p>	<p>Select Foot</p> <p>SF Contain Foot T1 Platinum Metallic PR6 Silver</p> <p>S F T 1</p>	<p>Select Pull</p> <p>A Arch PRO Silver R Radius N Integral S Square PR6 Silver</p> <p>S P R 6</p>	<p>Select Paint Color</p> <p>See page 640</p> <p>P 7 T</p>	<p>Select Front Paint</p> <p>NA Matches Case</p> <p>N A</p>	<p>Select Panel Paint</p> <p>NA Matches Case</p> <p>N A</p>	<p>Select Lock</p> <p>L Standard X Lock Omit Lock (- \$20)</p> <p>L</p>
--	---	---	---	--	--	--



Icon Legend on page 19

Contain® Footed Metal Personal Towers with Laminate Fronts

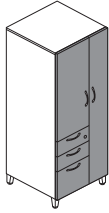

DESCRIPTION	MODEL	SHIP WEIGHT	CUBE	LIST PRICE BY PAINT GRADE		
				P1	P2	P3
Footed Personal Tower with Laminate Fronts, Door/Box/Box/File						
65"H x 24"W x 24"D, Wardrobe Left	HSTF652424LBBFL	178	25.8	\$2466	\$2543	\$2611
65"H x 24"W x 24"D, Wardrobe Right	HSTF652424RBBFL	178	25.8	\$2466	\$2543	\$2611
50"H x 24"W x 24"D, Wardrobe Left	HSTF502424LBBFL	146	19.8	\$2316	\$2393	\$2461
50"H x 24"W x 24"D, Wardrobe Right	HSTF502424RBBFL	146	19.8	\$2316	\$2393	\$2461
42"H x 24"W x 24"D, Wardrobe Left	HSTF422424LBBFL	132	18.2	\$2005	\$2055	\$2130
42"H x 24"W x 24"D, Wardrobe Right	HSTF422424RBBFL	132	18.2	\$2005	\$2055	\$2130

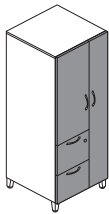

Footed Personal Tower with Laminate Fronts, Door/File/File						
65"H x 24"W x 24"D, Wardrobe Left	HSTF652424LFFL	178	25.8	\$2415	\$2492	\$2560
65"H x 24"W x 24"D, Wardrobe Right	HSTF652424RFFL	178	25.8	\$2415	\$2492	\$2560
50"H x 24"W x 24"D, Wardrobe Left	HSTF502424LFFL	146	19.8	\$2265	\$2342	\$2410
50"H x 24"W x 24"D, Wardrobe Right	HSTF502424RFFL	146	19.8	\$2265	\$2342	\$2410
42"H x 24"W x 24"D, Wardrobe Left	HSTF422424LFFL	132	18.2	\$1955	\$2005	\$2080
42"H x 24"W x 24"D, Wardrobe Right	HSTF422424RFFL	132	18.2	\$1955	\$2005	\$2080

NOTES:

- Metal chassis with laminate drawer/door fronts.
- Steel frame provides durability.
- Leveling glides can be adjusted from outside or inside the case.
- Heavy-duty, telescoping ball-bearing slides.
- Baked, epoxy/polyester, powder coating finish.
- One lock secures doors and drawers.
- Pencil tray standard in top box drawer.
- One box divider standard in each box drawer.
- One crossrail standard in each file drawer.

ⓘ Locking units equipped with HON "One Key" interchangeable core removable locks. Keyed alike core model HF23S, in Satin, must be ordered separately. See page 649.

HOW TO SPECIFY

Select Model Number H S T F 6 5 2 4 2 4 L B B F L .	Select Foot SF Contain Foot T1 Platinum Metallic PR6 Silver	Select Pull A Arch PRO Silver S Square PR6 Silver	Select Case Paint See page 640 P 7 T .	Select Laminate See page 640 L S A 1 .	Select Lock L Standard Lock X Omit Lock (- \$20) L
---	---	--	---	---	--

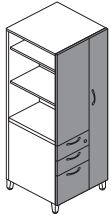

DESCRIPTION	MODEL	SHIP WEIGHT	CUBE	LIST PRICE BY PAINT GRADE		
				P1	P2	P3
Footed Side Access Tower with Laminate Fronts, Shelves/Box/Box/File						
65"H x 24"W x 24"D, Wardrobe Left	HSTSF652424LBBFL	178	25.8	\$2606	\$2683	\$2751
65"H x 24"W x 24"D, Wardrobe Right	HSTSF652424RBBFL	178	25.8	\$2606	\$2683	\$2751
50"H x 24"W x 24"D, Wardrobe Left	HSTSF502424LBBFL	146	19.8	\$2447	\$2524	\$2592
50"H x 24"W x 24"D, Wardrobe Right	HSTSF502424RBBFL	146	19.8	\$2447	\$2524	\$2592
42"H x 24"W x 24"D, Wardrobe Left	HSTSF422424LBBFL	132	18.2	\$2219	\$2269	\$2344
42"H x 24"W x 24"D, Wardrobe Right	HSTSF422424RBBFL	132	18.2	\$2219	\$2269	\$2344

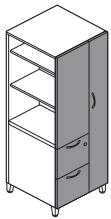

Footed Side Access Tower with Laminate Fronts, Shelves/File/File						
65"H x 24"W x 24"D, Wardrobe Left	HSTSF652424LFFFL	178	25.8	\$2555	\$2632	\$2700
65"H x 24"W x 24"D, Wardrobe Right	HSTSF652424RFFFL	178	25.8	\$2555	\$2632	\$2700
50"H x 24"W x 24"D, Wardrobe Left	HSTSF502424LFFFL	146	19.8	\$2396	\$2473	\$2541
50"H x 24"W x 24"D, Wardrobe Right	HSTSF502424RFFFL	146	19.8	\$2396	\$2473	\$2541
42"H x 24"W x 24"D, Wardrobe Left	HSTSF422424LFFFL	132	18.2	\$2168	\$2218	\$2293
42"H x 24"W x 24"D, Wardrobe Right	HSTSF422424RFFFL	132	18.2	\$2168	\$2218	\$2293

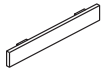

Tower Kickplates (Field Installable)						
For 24" Tower, Left	HSTAKL	2	0.3	\$160	\$168	\$173
For 24" Tower, Right	HSTAKR	2	0.3	\$160	\$168	\$173

Specify: Model.Paint
SPECIFYING EXAMPLE: HSATKL.P

NOTES:

- Towers can be used to support a worksurface. In order to do so, order bracket model HSTB2W1.
 - Metal chassis with laminate drawer/door fronts.
 - Steel frame provides durability.
 - Leveling glides can be adjusted from outside or inside the case.
 - Heavy-duty, telescoping ball-bearing slides.
 - Baked, epoxy/polyester, powder coating finish.
 - One lock secures doors and drawers.
 - Pencil tray standard in top box drawer.
 - One box divider standard in each box drawer.
 - One crossrail standard in each file drawer.
- ⚠ Locking units equipped with HON "One Key" interchangeable core removable locks. Keyed alike core model HF23S, in Satin, must be ordered separately. See page 649.

HOW TO SPECIFY

<p>Select Model Number</p> <p>H S T S F 6 5 2 4 2 4 L B B F L</p>	<p>Select Foot</p> <p>SF Contain Foot T1 Platinum Metallic PR6 Silver</p> <p>S F T 1</p>	<p>Select Pull</p> <p>A Arch PRO Silver S Square PR6 Silver</p> <p>S P R 6</p>	<p>Select Case Paint</p> <p>See page 640</p> <p>P 7 T</p>	<p>Select Laminate</p> <p>See page 640</p> <p>L S A 1</p>	<p>Select Lock</p> <p>L Standard Lock X Omit Lock (- \$20)</p> <p>L</p>
--	---	--	--	--	---



Icon Legend on page 19

EMPOWER® Contain® Metal Pedestals

WORKSTATIONS

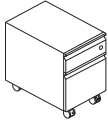

DESCRIPTION	MODEL	SHIP WEIGHT	CUBE	LIST PRICE BY PAINT GRADE		
				P1	P2	P3
Mobile Pedestal with Metal Fronts, Box/File						
21"H x 15"W x 18"D	HSPM211518BFM(?)	63.5	4.4	\$566	\$594	\$622
21"H x 15"W x 24"D	HSPM211524BFM(?)	61.9	5.7	\$607	\$635	\$663

NOTES: Ball-bearing suspension on box and file drawer. (100%) Drawers color to be interior gray steel. See page 542 for Pedestal Seat. File drawer has high sides and back for filing front-to-back and side-to-side. Counterweight standard on all mobile peds. Optional steel tops and pedestal seat cushions available. See pages 540 and 543. Pencil tray standard in top box drawer. One box divider standard in each box drawer. One crossrail standard in each file drawer.

- ! Available drawer fronts; R-Pull, A-Pull and N-Pull. A-Pull available in Satin Chrome only.
- ! Peds come with a plinth base, footed base or mobile base.

HOW TO SPECIFY

Select Model Number

Replace (?) with handle choice

- A** Satin Chrome Arch
- N** Full Face Integral
- R** Full Radius

H S P M 2 1 1 5 1 8 B F M A .

Select Paint Color

See page 478 Contain® Storage finish options

P .

Select Lock Option

- L** Standard Lock
- X** Omit Lock (deduct \$20)

L

EMPOWER® Contain® Footed Metal Pedestals

GSA SIN 33721 EXCEPT AS NOTED



Icon Legend on page 19

WORKSTATIONS

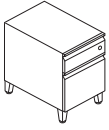

DESCRIPTION	MODEL	SHIP WEIGHT	CUBE	LIST PRICE BY PAINT GRADE		
				P1	P2	P3
Footed Freestanding Pedestal with Metal Fronts, Box/File						
22"H x 15"W x 18"D	HSPFSF221518BFM(?)	66.8	4.4	\$665	\$693	\$721
22"H x 15"W x 24"D	HSPFSF221524BFM(?)	73.1	5.7	\$703	\$731	\$759

NOTES: Ball-bearing suspension on box and file drawer. (100%) Drawers color to be interior gray steel. File drawer has high sides and back for filing front-to-back and side-to-side. Counterweight standard on all mobile peds. Optional steel tops and pedestal seat cushions available. See pages 540 and 543. Pencil tray standard in top box drawer. One box divider standard in each box drawer. One crossrail standard in each file drawer.

- Available drawer fronts; R-Pull, A-Pull and N-Pull. A-Pull available in Satin Chrome only.
- Peds come with a plinth base, footed base or mobile base.

DESCRIPTION	MODEL	SHIP WEIGHT	CUBE	LIST PRICE
Counterweight — Freestanding Support Pedestals or Systems Support and Mobile Pedestals	HPCW1	18	0.1	\$201

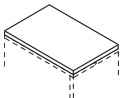

OPEN MARKET



DESCRIPTION	MODEL	SHIP WEIGHT	CUBE	FABRIC PRICE CODES			
Pedestal Seat							
15"W x 22 7/8"D x 2"H	HPSEAT24ND	10	1.2	1	\$200	8	\$396
				2	\$224	9	\$427
				3	\$248	10	\$458
				4	\$272	11	\$489
				5	\$303	12	\$520
				6	\$334	L	—
				7	\$365		

NOTES: For seating fabrics, see pages 22-24.
SPECIFYING EXAMPLE: HPSEAT24ND.APN23

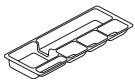

DESCRIPTION	MODEL	SHIP WEIGHT	CUBE	LIST PRICE
Optional Pencil Tray	HV-UT1		0.5	\$69

NOTES: For additional information see the Workplace Tools section in the 2021 Shared Spaces Pricer.

- For use with mobile and freestanding pedestal models.
- No specification required.

HOW TO SPECIFY

Select Model Number

Replace (?) with handle choice

- A Satin Chrome Arch
- N Full Face Integral
- R Full Radius

H S P F S F 2 2 1 5 1 8 B F M A .

Select Paint Color

See page 478 Contain® Storage finish options

P .

Select Lock Option

- L Standard Lock
- X Omit Lock (deduct \$20)

L .

Select Foot Color

- T1 Platinum Metallic
- PR6 Silver

T 1

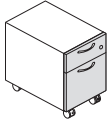

DESCRIPTION	MODEL	SHIP WEIGHT	CUBE	LIST PRICE BY PAINT GRADE		
				P1	P2	P3
Mobile Pedestal with Laminate Fronts, Box/File						
21"H x 15"W x 18"D, Arch Pull	HSPM211518BFL(?)	65.3	4.4	\$724	\$752	\$780
21"H x 15"W x 24"D, Arch Pull	HSPM211524BFL(?)	63.7	5.7	\$765	\$793	\$821

NOTES: Ball-bearing suspension on box and file drawer. (100%) Drawers color to be interior gray steel. File drawer has high sides and back for filing front-to-back and side-to-side. Counterweight standard on all mobile peds. See page 542 for Pedestal Seat. Optional pedestal seat cushions available. See page 543. Pencil tray standard in top box drawer. One box divider standard in each box drawer. One crossrail standard in each file drawer.

- ! Drawer Fronts available with Satin Chrome Arch only.
- ! Peds come with a plinth base, footed base or mobile base.

HOW TO SPECIFY

<p>Select Model Number</p> <p>Replace (?) with handle choice</p> <p>A Satin Chrome Arch</p>	<p>Select Paint Color</p> <p>See page 478 Contain® Storage finish options</p>	<p>Select Lock Option</p> <p>L Standard Lock X Omit Lock (deduct \$20)</p>	<p>Select Laminate Option</p> <p>L1 (no upcharge)</p> <p>COGN Cognac C Harvest N Mahogany MOCH Mocha D Natural Maple PINC Pinnacle F Shaker Cherry</p> <p>L2 (\$10 upcharge)</p> <p>LLA1 Lowell Ash LNRI Natural Recon LPE1 Phantom Ecru LPT1 Portico Teak LSW1 Skyline Walnut</p>
<p>H S P M 2 1 1 5 1 8 B F L A .</p>	<p>P .</p>	<p>L .</p>	<p>C</p>

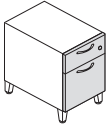

SIN 33721

DESCRIPTION	MODEL	SHIP WEIGHT	CUBE	LIST PRICE BY PAINT GRADE		
				P1	P2	P3
Footed Freestanding Pedestal with Laminate Fronts, Box/File 22"H x 15"W x 18"D, Arch Pull	HSPFSF221518BFL(?)	69.0	4.4	\$823	\$851	\$879
22"H x 15"W x 24"D, Arch Pull	HSPFSF221524BFL(?)	75.3	5.7	\$861	\$889	\$917

NOTES: Ball-bearing suspension on box and file drawer. (100%) Drawers color to be interior gray steel. File drawer has high sides and back for filing front-to-back and side-to-side. Counterweight standard on all mobile peds. See below for pedestal seat. Optional pedestal seat cushions available. See page 543. Pencil tray standard in top box drawer. One box divider standard in each box drawer. One crossrail standard in each file drawer. See Brigade® pedestals on page 630 for additional pedestal options. See pages 723-724 for Pedestal Accessories.

- ❗ Drawer Fronts available with Satin Chrome Arch only.
- ❗ Peds come with a plinth base, footed base or mobile base.

HOW TO SPECIFY

<p>Select Model Number</p> <p>Replace (?) with handle choice</p> <p>A Satin Chrome Arch</p>	<p>Select Paint Color</p> <p>See page 478 Contain® Storage finish options</p>	<p>Select Lock Option</p> <p>L Standard Lock X Omit Lock (deduct \$20)</p>	<p>Select Laminate Option</p> <p>L1 (no upcharge)</p> <p>COGN Cognac C Harvest N Mahogany MOCH Mocha D Natural Maple PINC Pinnacle F Shaker Cherry</p> <p>L2 (\$10 upcharge)</p> <p>LLA1 Lowell Ash LNR1 Natural Recon LPE1 Phantom Ecrú LPT1 Portico Teak LSW1 Skyline Walnut</p>	<p>Select Foot Color</p> <p>T1 Platinum Metallic PR6 Silver</p>
H S P F S F 2 2 1 5 1 8 B F L A .	P .	L .	C .	T 1

DESCRIPTION	MODEL	SHIP WEIGHT	CUBE	FABRIC PRICE CODES			
Pedestal Seat 15"W x 22 ⁷ / ₈ "D x 2"H	HPSEAT24ND	10 Ⓞ	1.2	1	\$200	8	\$396
NOTES: For seating fabrics, see pages 22-24.				2	\$224	9	\$427
				3	\$248	10	\$458
				4	\$272	11	\$489
				5	\$303	12	\$520
				6	\$334	L	—
				7	\$365		



HOW TO SPECIFY

<p>Select Model Number</p>	<p>Select Fabric</p> <p>See pages 476-477 for seating fabric options</p>
H P S E A T 2 4 .	A P N 2 3



Icon Legend on page 19

EMPOWER[®] Flagship[®] Mobile Pedestals

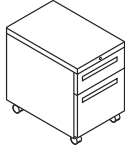



H15923N
SIN 33721

DESCRIPTION	MODEL	SHIP WEIGHT	CUBE	LIST PRICE BY PAINT GRADE		
				P1	P2	P3
Mobile Pedestals — Box/File 15"W x 22 ⁷ / ₈ "D x 22"H NOTES: Pencil tray standard in top box drawer. One box divider standard in each box drawer. One crossrail standard in each file drawer. File drawers have high sides for filing front-to-back. Steel ball-bearing suspension on file and box drawers. See pages 723-724 for accessories and pedestal utilization information. Arch pull available in Satin Chrome only. Choose from any of three pull options with no upcharge. Available in Arch (A), Full Face Integral (N) and Full Radius (R) Drawer Pulls. See page 627 for pull options. Equipped with HON "One Key" interchangeable core removable locks. Counterweight standard. Omit lock-option available. See page 746 for ordering instructions. See Brigade [®] pedestals on page 630 for additional pedestal options. See pages 723-724 for Pedestal Accessories.	H15923(?)	92	6.0	\$585	\$613	\$641

HOW TO SPECIFY

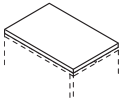
<p>Select Model Number</p> <p>A Satin Chrome Arch N Full Face Integral R Full Radius</p> <p>H 1 5 9 2 3 A</p>	<p>Select Lock Option</p> <p>L Lock (no upcharge) X Omit Lock (deduct \$20)</p> <p>X</p>	<p>Select Paint Color</p> <p>See page 478</p> <p>T 1</p>
---	--	--

DESCRIPTION	MODEL	SHIP WEIGHT	CUBE	FABRIC PRICE CODES												
 <p>Pedestal Seat 15"W x 22⁷/₈"D x 2"H</p> <p>NOTES: For seating fabrics, see pages 22-24.</p>	HPSEAT24ND	10 	1.2	1 \$200	8 \$396	2 \$224	9 \$427	3 \$248	10 \$458	4 \$272	11 \$489	5 \$303	12 \$520	6 \$334	L —	7 \$365

OPEN MARKET 

HOW TO SPECIFY

<p>Select Model Number</p> <p>H P S E A T 2 4</p>	<p>Select Fabric</p> <p>See pages 476-477 for seating fabric options</p> <p>A P N 2 3</p>
---	---

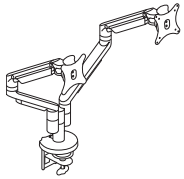

DESCRIPTION

Dual Dynamic Monitor Arm

- 150° of rotation at base with optional 360° rotation.
- Arms extend 22" and retract up to 3".
- Monitor mount rotates 180° and tilts +/-30°.
- Monitor can be rotated from landscape to portrait position.

! Arms hold monitors from 6.2-18 lbs. Optional counterweight HPACW available to support monitors as low as 5 lbs. (see the Workplace Tools section in the 2021 Shared Spaces Pricer).

MODEL	SHIP WEIGHT	CUBE	LIST PRICE
HMASD	17.0	1.1	\$900

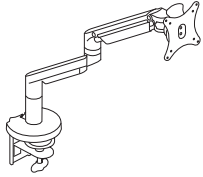

Single Dynamic Monitor Arm

- 180° of rotation at base with optional 360° rotation.
- Arms extend 22" and retract up to 3".
- Monitor mount rotates 180° and tilts +/-30°.
- Monitor can be rotated from landscape to portrait position.

! Arms hold monitors from 6.2-18 lbs. Optional counterweight HPACW available to support monitors as low as 5 lbs. (see the Workplace Tools section in the 2021 Shared Spaces Pricer).

HMASTS	11.5	0.8	\$468
---------------	------	-----	--------------

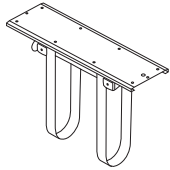

360° Swivel CPU Holder with Adjustable Straps

- Supports CPUs 3¾" wide up to 64" perimeter and holds up to 75 lbs.
- 360° rotation.
- Ships complete and includes necessary mounting hardware and instruction sheet.

! Available in Black only, no specification needed.

HCPU1	7.0	0.2	\$243
--------------	-----	-----	--------------

SIN 33721

NOTES:

- For additional information see the Workplace Tools section in the 2021 Shared Spaces Pricer.



Monitor Arms

- Arms fold back to post to allow more desktop room.
- Arms feature double extension, allowing 20"+ of back and forth movement.
- Cable management on both pole and arm assemblies.
- Counterbalance adjustment provides stability for monitors up to 17.6 lbs per arm.
- Made of high quality aluminum alloy material.
- See the Workplace Tools section in the 2021 Shared Spaces Pricer for additional monitor arm models.

HOW TO SPECIFY

<p>Select Model Number</p>	<p>Select Finish</p> <p><i>Specify for models HMASD and HMASTS only</i></p> <p>SVR Silver BLK Black</p>
<p>HMASD.</p>	<p>SVR</p>

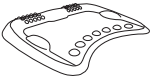
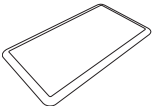
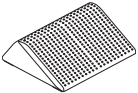

	DESCRIPTION	MODEL	SHIP WEIGHT	CUBE	LIST PRICE
	Rectangle Wobble Board — Anti-Fatigue Mat 18"D x 3"H x 22¼"W ⓘ Available in Black (T) finish ONLY. Recommended weight capacity not to exceed 250 pounds. HON 5-Year Limited Warranty. SPECIFYING EXAMPLE: HVL981.T	HVL981 Ⓢ	10.0 Ⓢ	0.9	\$121
	Round Wobble Board — Anti-Fatigue Mat 18½"D x 2⅝"H x 18½"W ⓘ Available in Black (T) finish ONLY. Recommended weight capacity not to exceed 250 pounds. HON 5-Year Limited Warranty. SPECIFYING EXAMPLE: HVL982.T	HVL982 Ⓢ	5.8 Ⓢ	0.6	\$103
	Ergonomic Anti-Fatigue Mat 25"D x 2¾"H x 29⅞"W ⓘ Available in Black ONLY. No specification needed. SPECIFYING EXAMPLE: HBEAFM1	HBEAFM1	7.0	1.4	\$219
	Rectangle Anti-Fatigue Mat 20"D x ¾"H x 36"W ⓘ Available in Black ONLY. No specification needed. SPECIFYING EXAMPLE: HBAFM2036	HBAFM2036 Ⓢ	5.4	0.4	\$100
	Footrest — Anti-Slip Cover 13¾"D x 5½"H x 16"W ⓘ Available in Black (T) finish ONLY. Recommended weight capacity not to exceed 250 pounds. HON 5-Year Limited Warranty. SPECIFYING EXAMPLE: HVL991.T	HVL991	7.0 Ⓢ	0.9	\$82

NOTES:

Ⓢ Discontinued 1/1/21.

HOW TO SPECIFY

Select Model Number	Select Finish
H V L 9 8 1 .	T Black
	T

NOTES

SYSTEMS SHARED COMPONENTS



Systems Worksurfaces, Accelerate® Panels, Systems Overhead Storage, Voi® O-Legs and Storage shown with Lota® Task Chairs.

SYSTEMS SHARED COMPONENTS

Panel-based workstations make efficient use of space, giving your people a place of their own that's still part of the action. Modular components are easy to specify and install, so you can configure them just about any which way — and reconfigure fast when your needs change. Systems models integrate seamlessly with Abode, Abound, Accelerate, Empower and Voi models and can be configured to create freestanding or height adjustable workstations.

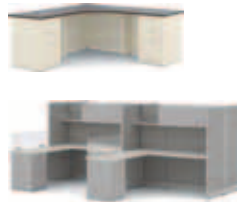

FEATURES

- Systems worksurfaces and supports can be used with Abode, Abound, Accelerate, Coordinate, Empower and Voi products.
- Systems electrical and data components can be used with Abode, Abound, Accelerate and Empower products.
- Systems storage can be used with Abound and Accelerate products.

SYSTEMS OVERHEAD AND SHELVES SPECIFYING

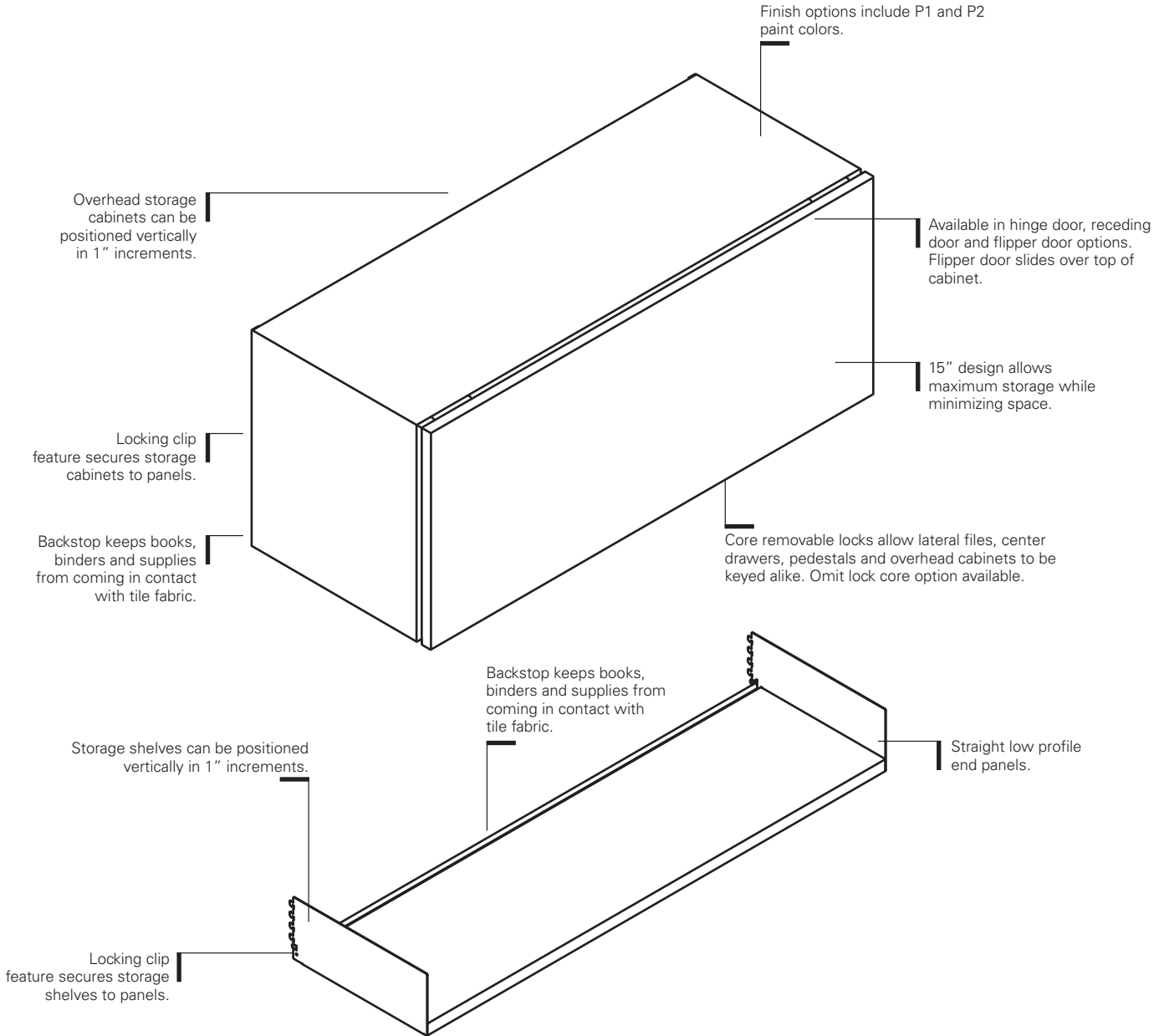

PRODUCT DIMENSIONS

Overhead Storage Cabinet

Width 24", 30", 36", 42", 48", 60"

Inside width Flipper and Receding door — $\frac{3}{8}$ " less than width
Hinged door — $1\frac{3}{4}$ " less than width

Depth $14\frac{7}{8}$ "

Inside depth $12\frac{7}{8}$ "

Height 15"

Inside height $12\frac{3}{4}$ "

Open Shelf

Width 24", 30", 36", 42", 48", 60"

Depth $14\frac{3}{8}$ "

Height $5\frac{5}{8}$ "

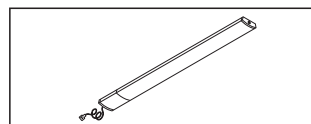

Task lights can be mounted beneath storage shelves and overhead storage cabinets.

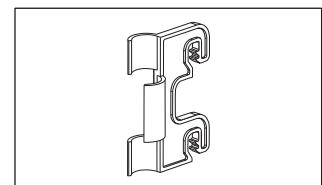

Cord retainer clips fasten into panel slots to anchor power cords. Available in black only. Clips are provided with undershelf mounted task lights.

SYSTEMS OVERHEAD AND SHELVES SPECIFYING

SPECIFICATION GUIDELINES

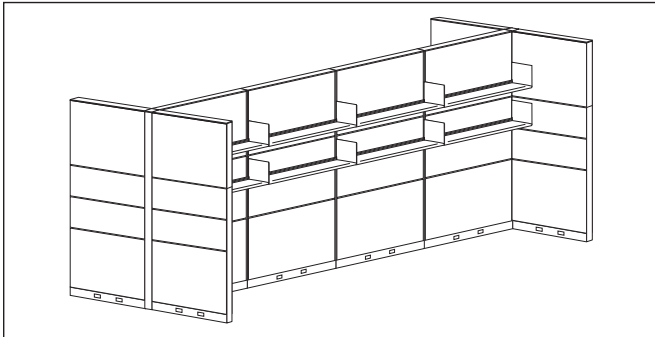

In a panel run, only two overhead storage cabinets or open storage shelves are recommended per panel side. When suspending overhead storage off-module only one storage unit per panel side is allowed.

When overhead storage units are suspended from stacking frames, the following guidelines should be adhered to:

A maximum of two overhead storage units can be suspended from each side of stacking frames on any given panel.

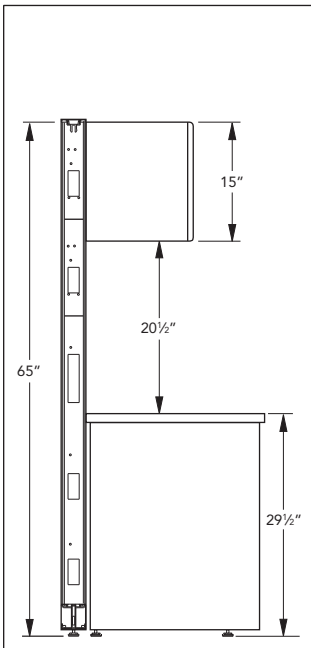

Overhead Storage cabinets and the **Open Shelf** can also be mounted to a maximum height of 65"H on all systems. Voi overheads not to be mounted on Accelerate stackers.

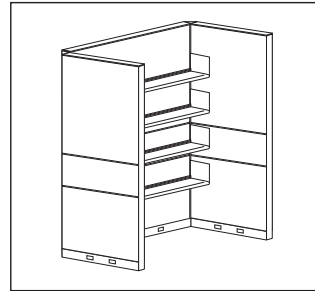

No limitation to the number of units on structural frames when units are spaced 12" apart and when the run is supported with return panels of equal height to the spine wall on each side of storage shelves or overhead storage cabinets.

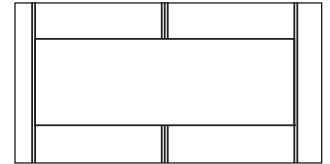

Storage shelf and overhead width must correspond with width of panel(s). It is possible to span two panels when combined panel width equals cabinet or shelf width.

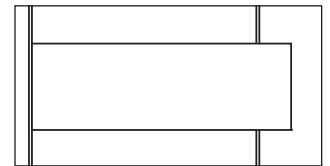

Overhead Cabinets can be mounted on a panel equal to or up to 18" narrower than cabinet.

Not applicable for ETA overheads, Voi overheads, and shelves.

SYSTEMS

Overhead and Shelves

GSA SIN 33721



Icon Legend on page 19

WORKSTATIONS

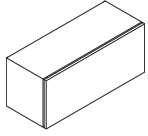

DESCRIPTION

Metal Flipper Door Overheads

24"W x 14³/₈"D x 15"H
 30"W x 14³/₈"D x 15"H
 36"W x 14³/₈"D x 15"H
 42"W x 14³/₈"D x 15"H
 48"W x 14³/₈"D x 15"H
 60"W x 14³/₈"D x 15"H
 72"W x 14³/₈"D x 15"H

MODEL

SHIP WEIGHT

CUBE

LIST PRICE BY PAINT GRADE

P1

P2

HRVOH24FM	35	3.6	\$542	\$591
HRVOH30FM	38	4.4	\$551	\$600
HRVOH36FM	41	5.3	\$577	\$626
HRVOH42FM	46	6.1	\$605	\$654
HRVOH48FM	52	6.9	\$632	\$681
HRVOH60FM	62	8.6	\$833	\$882
HRVOH72FM	82	10.6	\$955	\$1004

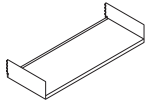

Open Shelf

24"W x 14³/₈"D x 5⁵/₈"H
 30"W x 14³/₈"D x 5⁵/₈"H
 36"W x 14³/₈"D x 5⁵/₈"H
 42"W x 14³/₈"D x 5⁵/₈"H
 48"W x 14³/₈"D x 5⁵/₈"H
 60"W x 14³/₈"D x 5⁵/₈"H
 72"W x 14³/₈"D x 5⁵/₈"H

HRVSH24	13	1.2	\$233	\$250
HRVSH30	15	1.5	\$253	\$270
HRVSH36	16	1.8	\$269	\$286
HRVSH42	17	1.9	\$279	\$296
HRVSH48	18	2.3	\$291	\$308
HRVSH60	20	2.9	\$357	\$374
HRVSH72	32	3.6	\$466	\$483

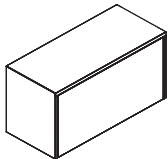

Recessed Door Overhead

30"W x 13³/₈"D x 15"H
 36"W x 13³/₈"D x 15"H
 42"W x 13³/₈"D x 15"H
 48"W x 13³/₈"D x 15"H
 60"W x 13³/₈"D x 15"H

HRVOH1530RM	38	5.7	\$699	\$752
HRVOH1536RM	41	6.8	\$737	\$790
HRVOH1542RM	46	7.8	\$784	\$837
HRVOH1548RM	52	8.9	\$849	\$902
HRVOH1560RM	62	11.2	\$1287	\$1340

NOTES:

- Overhead Storage Cabinets with doors are standard with a factory installed core removable lock located on the underside of the cabinet.
- All units feature an anti-dislodgement device.
- 60" and 72"W units are one piece cabinet with two doors.
- Upmount kits can be used with all metal overheads.

Keyed alike cores must be ordered separately — see page 746.

HOW TO SPECIFY

Select Model Number

HRVOH24FM

Select Paint Color

See page 455

T4

Select Lock Option











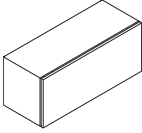





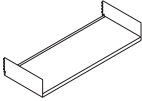

L Lock
 X Omit Lock (deduct \$20) (where applicable)
 See page 746

L





SYSTEMS

ETA Overheads and Shelves

	DESCRIPTION	MODEL	SHIP WEIGHT	CUBE	LIST PRICE BY PAINT GRADE	
					P1	P2
	Flipper Door Overheads					
	24"W x 13"D x 15"H	HEOHRTA1524FD	21	1.6	\$434	\$483
	30"W x 13"D x 15"H	HEOHRTA1530FD 	24	1.6	\$441	\$490
	36"W x 13"D x 15"H	HEOHRTA1536FD 	27	1.6	\$463	\$512
	42"W x 13"D x 15"H	HEOHRTA1542FD	30	1.8	\$486	\$535
	48"W x 13"D x 15"H	HEOHRTA1548FD 	33	2.1	\$505	\$554
	60"W x 13"D x 15"H	HEOHRTA1560FD 	42	2.5	\$667	\$716
72"W x 13"D x 15"H	HEOHRTA1572FD 	49	3.0	\$829	\$878	
	Open Shelves					
	24"W x 13"D x 5 5/8"H	HESHRTA24	10 	1.9	\$203	\$220
	30"W x 13"D x 5 5/8"H	HESHRTA30 	11 	1.9	\$219	\$236
	36"W x 13"D x 5 5/8"H	HESHRTA36 	12 	1.9	\$233	\$250
	42"W x 13"D x 5 5/8"H	HESHRTA42	13 	2.1	\$240	\$257
	48"W x 13"D x 5 5/8"H	HESHRTA48 	14 	2.4	\$254	\$271
	60"W x 13"D x 5 5/8"H	HESHRTA60 	16 	3.0	\$309	\$326
72"W x 13"D x 5 5/8"H	HESHRTA72	18 	3.5	\$365	\$382	

NOTES:

- Storage Cabinets with doors are standard with a factory installed core removable lock located on the underside of the cabinet.
 - All units feature an anti-dislodgement device.
 - Accepts under cabinet lighting.
 - ETA overheads and shelves ship flat packed.
 - Only one installer is needed to assemble an ETA overhead on a panel (all sizes).
 - Attachment brackets are attached to the back of the unit (included).
 - ETA overheads and shelves are slightly less deep than built-up models. Please note when using next to built-up models.
 - Order overhead and shelf to match the width of panel being used.
-  Keyed alike cores must be ordered separately — see page 746.
-  Cannot be used in off-modular applications because attachment bracket is attached to the back of the case and cannot be moved.

HOW TO SPECIFY

Select Model Number H E O H R T A 1 5 2 4 F D . T 1	Select Paint Color See page 455
---	---

SYSTEMS

Overhead Storage

GSA SIN 33721



Icon Legend on page 19

WORKSTATIONS

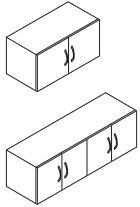

DESCRIPTION

Steel Front Hinged Door Overhead with Arch Pull

24"W x 15"D x 15"H
30"W x 15"D x 15"H
36"W x 15"D x 15"H
42"W x 15"D x 15"H
48"W x 15"D x 15"H

MODEL

HRVOHV24HMA
HRVOHV30HMA
HRVOHV36HMA
HRVOHV42HMA
HRVOHV48HMA

SHIP WEIGHT

32
36
42
52
56

CUBE

5.6
6.8
7.7
8.1
9.2

LIST PRICE BY PAINT GRADE

P1 **P2**

\$731 **\$780**
\$756 **\$805**
\$783 **\$832**
\$810 **\$859**
\$839 **\$888**

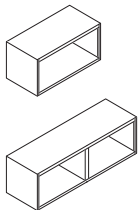

Open Storage Cabinet

24"W x 15"D x 15"H
30"W x 15"D x 15"H
36"W x 15"D x 15"H
42"W x 15"D x 15"H
48"W x 15"D x 15"H

HRVSHV24
HRVSHV30
HRVSHV36
HRVSHV42
HRVSHV48

21
26
29
32
37

5.6
6.8
7.7
8.1
9.2

\$666 **\$715**
\$688 **\$737**
\$717 **\$766**
\$743 **\$792**
\$771 **\$820**

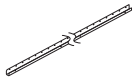

Abound®/Accelerate® Horizontal Wall Track for Overhead Storage

60"W

HTWTH

5

0.8

\$85

N/A

NOTES: Use when mounting overhead storage and when a permanent wall hanger kit is not desired. For 72"W overheads, use two wall tracks cut to 36".

⚠ Cannot be used with ETA storage or Voi®. Can only be used with systems flipper door, receding door and hinged door overheads.

NOTES:

- Overhead Storage Cabinets with doors are standard with a factory installed core removable lock located on the underside of the cabinet.
- Upmount kits can be used with all metal overheads.

⚠ Keyed alike cores must be ordered separately — see page 746.

HOW TO SPECIFY

Select Model Number

Select the Pull

A Satin Chrome Arch

H R V O H V 2 4 H M A .

Select Lock Option

L Lock
X Omit Lock (deduct \$20) (where applicable)
See page 746

L .

Select Paint Color

See page 455

T 4



Icon Legend on page 19

Laminate Front Overhead Storage

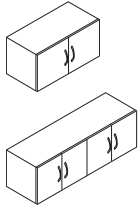

DESCRIPTION	MODEL	SHIP WEIGHT	CUBE	LIST PRICE BY PAINT GRADE	
				P1	P2
Laminate Front Hinged Door Overheads with Arch Pull					
24"W x 15"D x 15"H	HRVOHV24HLA	35	5.6	\$898	\$947
30"W x 15"D x 15"H	HRVOHV30HLA	40	6.8	\$926	\$975
36"W x 15"D x 15"H	HRVOHV36HLA	48	7.7	\$952	\$1001
42"W x 15"D x 15"H	HRVOHV42HLA	53	8.1	\$979	\$1028
48"W x 15"D x 15"H	HRVOHV48HLA	64	9.2	\$1003	\$1052

NOTES:

- Unit features metal chassis and laminate doors.
- Laminate fronts are available in L1 woodgrain only.
- Overhead Storage Cabinets with doors are standard with a factory installed core removable lock located on the underside of the cabinet.
- Upmount kits can be used with all metal overheads.

! Keyed alike cores must be ordered separately — see page 746.

HOW TO SPECIFY

<p>Select Model Number</p> <p>Select the Pull</p> <p>A Satin Chrome Arch</p>	<p>Select Lock Option</p> <p>L Lock X Omit Lock (deduct \$20) See page 746</p>	<p>Select Front Laminate Color</p> <p>L1 Woodgrain only See page 455</p>	<p>Select Case Paint Color</p> <p>See page 455</p>
<p>H R V O H V 2 4 H L A .</p>	<p>L .</p>	<p>H .</p>	<p>T 4</p>

VOI® Overhead Storage

GSA SIN 33721



Icon Legend on page 19

WORKSTATIONS

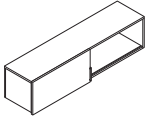

DESCRIPTION

Overhead Cabinet with One Sliding Door

36"W x 14¼"D x 14"H
42"W x 14¼"D x 14"H
48"W x 14¼"D x 14"H
60"W x 14¼"D x 14"H
66"W x 14¼"D x 14"H
72"W x 14¼"D x 14"H

MODEL	SHIP WEIGHT	CUBE	L1 LIST	L2 UPCHARGES	
				CABINET	DOOR
HLSL1436S	39	9.7	\$1020	\$25	\$20
HLSL1442S	48	9.7	\$1069	\$25	\$20
HLSL1448S	57	12.1	\$1100	\$25	\$20
HLSL1460S	69	13.3	\$1185	\$30	\$25
HLSL1466S	83	14.6	\$1308	\$30	\$25
HLSL1472S	95	15.9	\$1428	\$35	\$25

NOTES: Only available in laminate.

❗ Overhead and Stack-on storage units do not lock.

NOTES:

- Voi® Overhead Storage can be used with Accelerate® and Abound® panels.
- All Overhead Cabinets shown above and on next page can be used as a wall mount, panel mount or stack-on storage with O-leg.
- Can be mounted on O-legs, panel brackets or wall mount brackets. See page 556.
- Tackboards are available for wall mount storage applications.
- Sliding door overhead does not ship with a pull — door overhangs chassis to slide.
- Overhead cabinets with four doors are available in laminate or mixed materials.
- For all color specifying combinations, see matrix on page 173.
- Storage cases accept binder height items.
- Storage cube fits inside stack-on storage or overhead cabinet units to provide paper management.
- Wall mount brackets specified with unit. Brackets attach to case horizontally.
- For panel mounted applications, brackets and hardware are ordered separately, see page 604. Brackets attach to panel and case is screwed into brackets. Two brackets needed for 60" unit; three brackets needed for 66" and larger.
- If Wall Bracket option is selected, \$150 upcharge applies.
- For additional information see the Workplace Tools section in the 2021 Shared Spaces Pricer.

❗ Stack-on Storage must be placed over two full-height supports. Cannot be placed over non-supported sections such as returns using a flat bracket or tower-to-worksurface bracket.

HOW TO SPECIFY

Select Model Number For locking overhead models, add an "L" suffix (\$40 upcharge per model)	Select Cabinet Laminate See page 173	Select Door Laminate See page 173	Select Pull X No Pull	Specify Bracket Option X No Bracket W Wall Bracket (\$150 upcharge)
H L S L 1 4 7 2 S .	N .	N .	X .	W

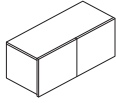

DESCRIPTION

Overhead Cabinet with Doors

- 36"W x 14¼"D x 14"H, 2 doors
- 42"W x 14¼"D x 14"H, 2 doors
- 48"W x 14¼"D x 14"H, 3 doors
- 60"W x 14¼"D x 14"H, 4 doors

MODEL	SHIP WEIGHT	CUBE	L1 LIST	L2 UPCHARGES	
				CABINET	DOOR
HLSL1436D	39	9.7	\$860	\$25	\$20
HLSL1442D	48	9.7	\$957	\$25	\$20
HLSL1448D	57	12.1	\$1062	\$25	\$30
HLSL1460D	115	13.3	\$1185	\$30	N/A

❗ 2-Door and 3-Door Overhead Cabinet with Doors models HLSL1436D – HLSL1448D available in laminate only. The 60" model HLSL1460D is available in all door finish options.

❗ Overhead and Stack-on storage units do not lock.

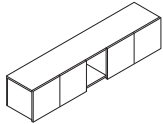

Overhead Cabinet with 4 Doors/Cubbies

- 66"W x 14¼"D x 14"H with 6" Cubbie
- 72"W x 14¼"D x 14"H with 12" Cubbie

HLSL1466D	126	14.6	\$1308	\$30	\$30
HLSL1472D	139	15.9	\$1428	\$35	\$35

NOTES: Doors available in laminate or mixed materials.

NOTES:

- Voi® Overhead Storage can be used with Accelerate® and Abound® panels.
- All Overhead Cabinets shown above and on previous page can be used as a wall mount, panel mount or stack-on storage with O-leg.
- Can be mounted on O-legs, panel brackets or wall mount brackets. See page 556.
- Tackboards are available for wall mount storage applications.
- Overhead cabinets with four doors are available in laminate or mixed materials.
- For all color specifying combinations, see matrix on page 173.
- Storage cases accept binder height items.
- Storage cube fits inside stack-on storage or overhead cabinet units to provide paper management.
- Wall mount brackets specified with unit. Brackets attach to case horizontally.
- For panel mounted applications, brackets and hardware are ordered separately, see page 604. Brackets attach to panel and case is screwed into brackets. Two brackets needed for 60" unit.
- If Wall Bracket option is selected, \$150 upcharge applies.

❗ Stack-on Storage must be placed over two full-height supports. Cannot be placed over non-supported sections such as returns using a flat bracket or tower-to-worksurface bracket.

❗ TIG doors not available with a locking option.

HOW TO SPECIFY

<p>Select Model Number</p> <p>For locking overhead models, add an "L" suffix (\$40 upcharge per model)</p>	<p>Select Cabinet Laminate</p> <p>See page 173</p>	<p>Select Door Material</p> <p>Upcharges for door selection: 4-Door \$315</p> <p>TIG Platinum Polymer with Frosted Glass</p> <p>Also available in laminate doors. See page 173.</p> <p>Not specified for models HLSL1436D – HLSL1448D. These models are available in laminate only.</p>	<p>Select Bracket Option</p> <p>X No Bracket W Wall Bracket (\$150 upcharge)</p>
HLSL1460D	N	TIG	X

VOI® Overhead and Stack-on Storage

GSA SIN 33721



Icon Legend on page 19

WORKSTATIONS

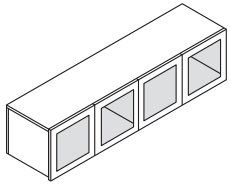

DESCRIPTION	MODEL	SHIP WEIGHT	CUBE	LIST PRICE BY LAMINATE GRADE	
				L1	L2
Overhead Cabinet with 4 Frosted, Metal Frame Doors 60"W x 14¼"D x 14"H ⓘ Must specify an X or W for attachment bracket option below.	HLSL1460M	115	11.4	\$1950	\$1980

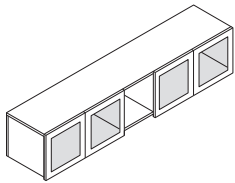

Overhead Cabinet with 4 Frosted, Metal Frame Doors 72"W x 14¼"D x 14"H with 12" Cubbie HLSL1472M	139	13.6	\$2198	\$2233
66"W x 14¼"D x 14"H with 6" Cubbie HLSL1466M	126	12.5	\$2073	\$2103

ⓘ Must specify an X or W for attachment bracket option below.



Storage Cube 12"W x 12"D HLSL1212	1	0.3	\$294	N/A
---	---	-----	--------------	------------

SPECIFYING EXAMPLE: HLSL1212.P8S

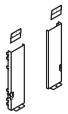

DESCRIPTION	MODEL	SHIP WEIGHT	CUBE	LIST PRICE BY PAINT GRADE	
				P1	P2
Voi® for Systems Stack-on Storage Panel Mounted Bracket Used to panel mount stack-on storage units Specify paint NOTES: Ships with one set of three brackets, which includes one right, one center and one left bracket. When using a 60"W overhead on a 60"W panel or a 72"W overhead on a 72"W panel, only two of the three brackets provided are required. SPECIFYING EXAMPLE: HLSLPMB.T1	HLSLPMB	3 ⓘ	1.0	\$131	\$141

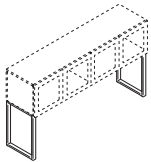

O-Leg Support for Overhead Cabinet Ships 2/pack 14⅞"D x 20½"H for 65"H Overhead Cabinet HLSL650S	8	1.1	\$479	\$483
14⅞"D x 5½"H for 50"H Overhead Cabinet HLSL500S	6	1.0	\$398	\$402

NOTES:

- Voi® Overhead Storage can be used with Accelerate® and Abound® panels.
- Overhead and Stack-on storage units do not lock.
- Use O-Leg Support models for Overhead Cabinets.
- If Wall Bracket option is selected, \$150 upcharge applies.
- Storage cube fits inside stack-on storage or wall mount units to provide paper management.
- Storage Cubes are available in the following colors: Atom (P8S), Bullseye (PJF), Ember (P8P), Ion (P8N), Iris (P8J), Krypton (P8F), and Regatta (P8M).

ⓘ Stack-on Storage must be placed over two full-height supports. Cannot be placed over non-supported sections such as returns using a flat bracket or tower-to-worksurface bracket.

HOW TO SPECIFY

Select Model Number HLSL1460M	Select Cabinet Laminate See page 173 N	Select Door Material TIG Platinum Metal Doors with Frosted Glass (no upcharge)	Select Bracket Option X No Bracket W Wall Bracket (\$150 upcharge)
---	---	--	---



Shared Overhead Storage Components

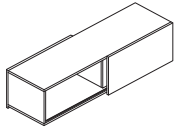

DESCRIPTION

Shared Overhead Storage — Left
 60"W x 17"D x 14"H
 72"W x 17"D x 14"H

MODEL

HLSL1760SOL
HLSL1772SOL

SHIP WEIGHT

115
 139

CUBE

14.8
 17.0

L1 LIST

\$1302
\$1570

L2 UPCHARGES
CABINET DOOR

\$20 \$40
\$25 \$40

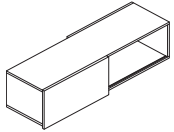

Shared Overhead Storage — Right
 60"W x 17"D x 14"H
 72"W x 17"D x 14"H

HLSL1760SOR
HLSL1772SOR

115
 139

14.8
 17.0

\$1302
\$1570

\$20 \$40
\$25 \$40



DESCRIPTION

Post Legs for Shared Storage
 14"H Post Legs
 22"H Post Legs

MODEL

HLSL140SPL
HLSL220SPL

SHIP WEIGHT

10
 13

CUBE

1.1
 3.7

LIST PRICE BY PAINT GRADE
P1 P2

\$346 \$350
\$384 \$388

NOTES: 14"H post legs on worksurfaces will span 35"H panel or shorter. 14"H post legs on low credenzas will span 30"H panel or shorter. 22"H post legs on worksurfaces will span 50"H panel or shorter. 22"H post legs on low credenzas will span 35"H panel or shorter. Specify paint.

SPECIFYING EXAMPLE: HLSL140SPL.T4



Panel Mount Bracket for Shared Overhead
 Panel Mount Bracket for Overhead Storage — Accelerate®
 Panel Mount Bracket for Overhead Storage — Abound®
 Panel Mount Bracket for Overhead Storage — Accelerate®/Abound® 42½"H panels only

HLSLPMBSOA
HLSLPMBSOB
HLSLPMBSO42

4
 4
 4

0.1
 0.1
 0.1

\$136 \$140
\$136 \$140
\$127 \$131

NOTES: Specify paint.

SPECIFYING EXAMPLE: HLSLPMBSOA.T4

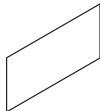

Markerboard for Shared Storage
 30"W x 15"D for use with 60"W Shared Overhead
 36"W x 15"D for use with 72"W Shared Overhead

HLSL1530SOMB
HLSL1536SOMB

6
 8

1.0
 1.0

\$132
\$179

NOTES: No specification necessary.

HOW TO SPECIFY

<p>Select Model Number</p> <p>HLSL1760SOL .</p>	<p>Select Chassis Laminate</p> <p>See page 173</p> <p>N .</p>	<p>Select Door Front Laminate</p> <p>See page 173</p> <p>N .</p>	<p>Select Pull Color</p> <p>T4 Champagne Metallic T1 Platinum Metallic WHIT White</p> <p>T4</p>
--	--	---	--

<p>Select Model Number</p> <p>HLSL140SPL .</p> <p>HLSLPMBSOA .</p>	<p>Select Paint Color</p> <p>See page 173</p> <p>T4</p> <p>T4</p>
---	--

SYSTEMS

Overhead and Shelves

GSA SIN 33721



Icon Legend on page 19

WORKSTATIONS

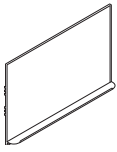

DESCRIPTION

Markerboards
 36"W x 24"H
 42"W x 24"H
 48"W x 24"H

MODEL

HHMRK36
HHMRK42
HHMRK48

SHIP WEIGHT

15 Ⓞ
 17 Ⓞ
 19 Ⓞ

CUBE

3.2
 4.0
 4.6

LIST PRICE

\$510
\$553
\$595

NOTES:

- Brushed aluminum finish around low-glare porcelain coated steel magnetic writing surface.
- Brushed aluminum marker tray attaches to frame.
- Width of markerboard must correspond to the width of the panel.
- Markerboards will attach to the Abound and Accelerate® frame with brackets provided.
- Able to use multiple markerboards next to each other and multiple boards per panel.

! No color specification required.

! Porcelain Markerboard cleaning instructions: For everyday cleaning, use Chlorox wipes. Use citrus cleaner if a permanent marker is used by accident. A citrus cleaner is not recommended for everyday use as it leaves residue.

HOW TO SPECIFY

Select Model Number

HHMRK36

DESCRIPTION

Tackboard
 20"W x 18"H
 24"W x 18"H
 30"W x 18"H
 36"W x 18"H
 42"W x 18"H
 48"W x 18"H
 60"W x 18"H
 72"W x 18"H

MODEL

HETB2018
HETB2418
HETB3018
HETB3618
HETB4218
HETB4818
HETB6018
HETB7218

SHIP WEIGHT

2
 3
 3
 8
 10
 12
 13
 15

CUBE

0.5
 0.6
 0.7
 0.9
 1.0
 1.2
 1.5
 1.8

LIST PRICE

\$106
\$130
\$152
\$173
\$193
\$212
\$235
\$258

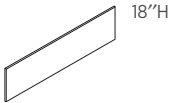

SPECIFYING EXAMPLE: HETB2018.APN15

NOTES:

- Works with both Abound® and Accelerate® panel systems.
- Specify fabric, see pages 396-397 for fabric options.

HOW TO SPECIFY

Select Model Number

HETB2018.

Select Fabric Color

APN15



Icon Legend on page 19

SYSTEMS Accessories

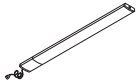

DESCRIPTION	MODEL	SHIP WEIGHT	CUBE	LIST PRICE
LED Task Lights				
17" LED Light with Power Supply (Single)	HLED17AS ⓘ	1.2 Ⓔ	0.05	\$420
31" LED Light with Power Supply (Single)	HLED31AS ⓘ	1.5 Ⓔ	0.09	\$564
17" LED Light with Power Supply for Daisy-chain (Starter)	HLED17A	1.0 Ⓔ	0.05	\$461
31" LED Light with Power Supply for Daisy-chain (Starter)	HLED31A	1.4 Ⓔ	0.09	\$619
17" LED Light with 8" Jumper Cord for Daisy-chain (Follower)	HLED17AUO ⓘ	1.0 Ⓔ	0.03	\$377
31" LED Light with 8" Jumper Cord for Daisy-chain (Follower)	HLED31AUO ⓘ	1.0 Ⓔ	0.05	\$503
Undercabinet Occupancy Sensor with 1" End to End Connector	HLEDOSA ⓘ	0.2 Ⓔ	0.01	\$89

NOTES: To use the daisy chain application, must start with model HLED17A or HLED31A. No finish specification required. Attaches magnetically to underside of overhead storage, or attaches with provided screws or double-sided tape. Occupancy sensor attaches to a single or starter LED light and will automatically turn the light off after no motion is detected for 30 minutes. Just like all the LED light models, the occupancy sensor features a soft-touch on/off switch. LED task lights have a lifetime of 50,000 hours and have a dimmer feature that allows the user to adjust the amount of light output.

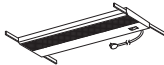

DESCRIPTION	MODEL	SHIP WEIGHT	CUBE	BASIC (NO SUFFIX REQUIRED)	CHICAGO CODE "CH"
Task Lights					
<ul style="list-style-type: none"> Slim profile design mounts recessed under storage unit and shelves with spring steel clips. T5 bulb included which contains less mercury than other types of bulbs. 9-foot black cord and switch off right rear corner. Electronic ballast for increased energy efficiency. 2 lights (HH870930) can be mounted under 60"W storage cabinets. 					
For 24"W storage cabinets or shelves, 18 ³ / ₈ "W x 3 ¹ / ₁₆ "D x 1 ¹ / ₈ "H	HH870924(?)	5.0	0.4	\$227	\$287
For 30"W and 36"W storage cabinets or shelves, 22 ¹ / ₈ "W x 3 ¹ / ₁₆ "D x 1 ¹ / ₈ "H	HH870930(?) ⓘ	7.0	0.6	\$231	\$301
For 42"W and 48"W storage cabinets or shelves, 34 ⁵ / ₈ "W x 3 ¹ / ₁₆ "D x 1 ¹ / ₈ "H	HH870942(?) ⓘ	10.0	0.9	\$250	\$317
For 60"W and 72"W storage cabinets or shelves, 46 ¹ / ₂ "W x 3 ¹ / ₁₆ "D x 1 ¹ / ₈ "H	HH870960(?)	12.0	1.1	\$270	\$337

NOTES: For additional information see the Workplace Tools section in the 2021 Shared Spaces Pricer.

ⓘ Color: Black.

Chicago Code Version — Specify: Model/"CH".
EXAMPLE: HH870924CH

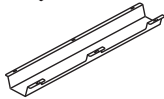
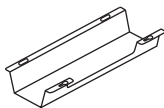

SIN 33721

DESCRIPTION	MODEL	SHIP WEIGHT	CUBE	LIST PRICE
Cable Management Troughs				
17"W — Single	HCTROUGH17	2.7	0.5	\$67
17"W — 10-Pack	HCTROUGH1710	14.0	0.5	\$620
36"W — Single	HCTROUGH36	4.9	0.9	\$113
36"W — 10-Pack	HCTROUGH3610	30.0	0.9	\$1045

- Cable management troughs ship flat packed.
- The troughs attach to underneath the worksurface with screws.
- The 17"W has one wire access cut out on the user side. The 36" has two wire access cut outs. These cut outs give users access to inside the trough without having to detach it from the worksurface.
- Color: Graphite.
- Material: Metal.
- TAA Compliant.

NOTES: For additional information see the Workplace Tools section in the 2021 Shared Spaces Pricer.

SYSTEMS Accessories

GSA SIN 33721



Icon Legend on page 19

WORKSTATIONS

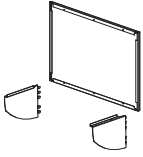

DESCRIPTION	MODEL	SHIP WEIGHT	CUBE	LIST PRICE BY PAINT GRADE	
				P1	P2
Upmount Kits for Overheads					
24"W	HRVUP24	7.0	0.3	\$155	\$173
30"W	HRVUP30	8.0	0.3	\$162	\$180
36"W	HRVUP36	10.0	0.4	\$167	\$185
42"W	HRVUP42	11.0	0.4	\$176	\$194
48"W	HRVUP48	12.0	0.5	\$183	\$201
60"W	HRVUP60	16.0	0.6	\$196	\$214

- Includes two upmount brackets, full back panel and installation hardware.
- Brackets require a clearance of 6½" below bottom of overhead cabinet.
- Full back panel adds ½" to depth of overhead case.

ⓘ Kit width must correspond to the width of the overhead case.



Overhead Shelf Dividers Shelf Dividers — package of 6	H38SHFDV	3.0 ⓘ	0.2	\$149	\$160
---	-----------------	-------	-----	--------------	--------------

Specify paint

NOTES:

- Upmount Bracket allows mounting of Overhead Cabinet up to 15" above height of panel.
- Upmount Kits for overheads can be used with flipper or receding door overheads. See page 550.

ⓘ Upmount Kits not for use on Accelerate stackers.

HOW TO SPECIFY

Select Model Number	Select Paint Color
See page 455	See page 455
H 3 8 S H F D V .	T 1



DESCRIPTION	MODEL	SHIP WEIGHT	CUBE	LIST PRICE BY PAINT GRADE	
				P1	P2
Cord Cover					
• Allows routing of task light cords.					
• Vertical height 10".	HECC10	0.7 ⓘ	0.2	\$38	\$45
• Vertical height 15".	HECC15	1.0 ⓘ	0.3	\$38	\$45
• Cord cover can be positioned into panel slots and used under task lights and under worksurfaces.					

Specify paint

HOW TO SPECIFY

Select Model Number	Select Paint Color
See page 455	See page 455
H E C C 1 0 .	T 1

ABOUND® Electrical and Data

Abound® features capabilities for cable management, including electrical, voice, and data. The 8-wire electrical system can be integrated at base pathway and beltline. The open structure of the frame allows voice and data cables to be routed both vertically and horizontally.

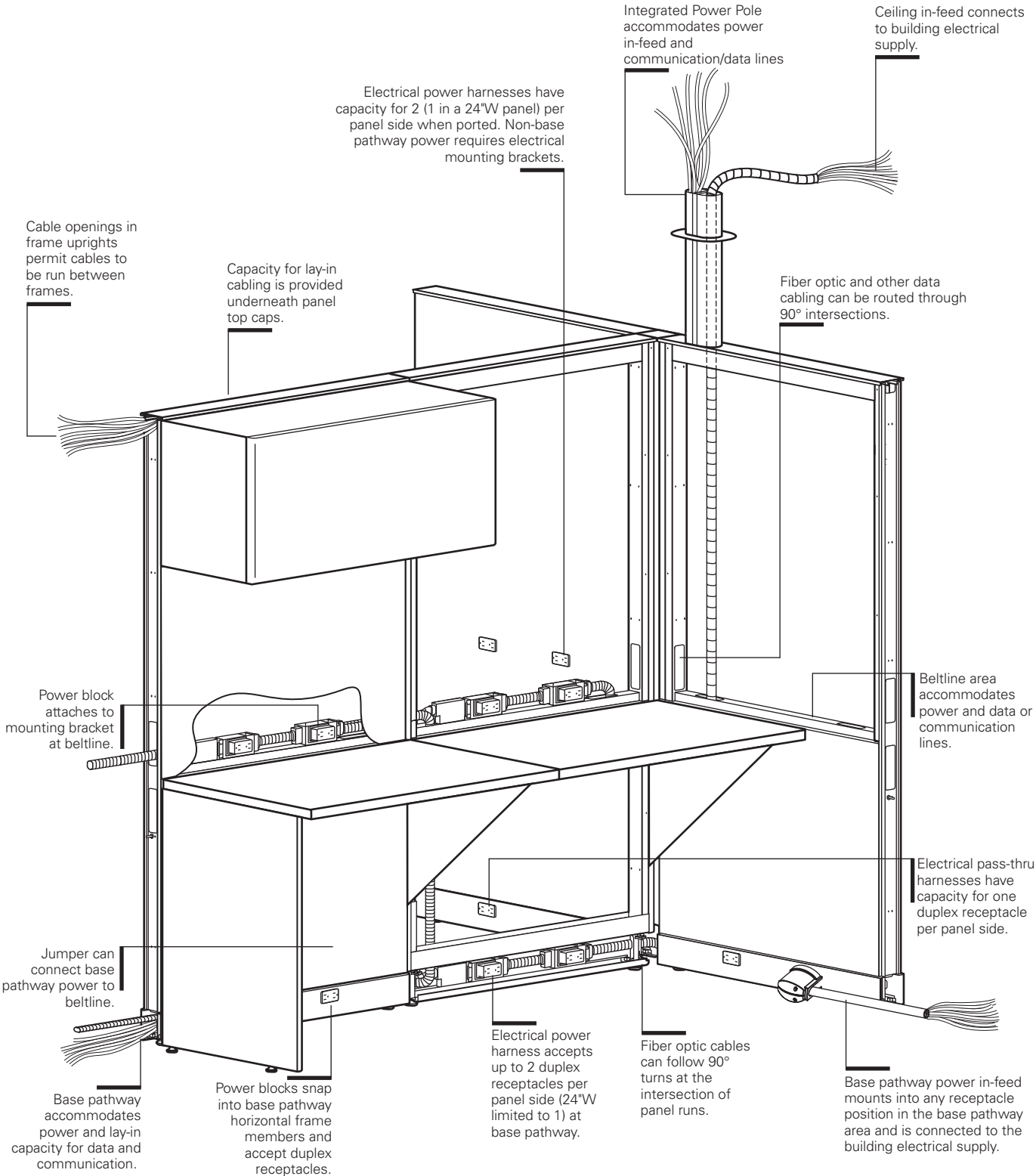

ABOUND® Electrical and Data

THE ABOUND ELECTRICAL SYSTEMS

Abound offers a choice of three electrical systems:

- Four-circuit, 3 + 1
- Four-circuit, 2 + 2
- Three-circuit, separate neutrals

All three systems utilize an 8-wire electrical system, rated at 20 amps per circuit (15 amps Canadian). See pages 567-568 for a detailed explanation of each electrical system.

Abound frames and electrical components are UL Listed. Electrical components are also CSA certified.

Installation and use of the electrical system, the number of receptacles used on a given circuit and connections to the building power supply should be in compliance with all local and national electrical codes.

Caution: Electrical equipment cords or extension cords MUST NOT BE ROUTED through cable openings in frame sides.

Abound's electrical harnesses are UL listed and are considered raceways themselves as defined by the National Electrical Code. This means there is no separation requirement between the electrical harnesses and communications cables per Sec. 800-52 of the National Electrical Code. Communication cables may be placed next to Abound's electrical components without a metal septum and will still meet the guidelines of the Telecommunications Industry Association for separation of power and data.

IN-FEEDS

Power in-feed cables deliver power from building to system. In-feed cables are housed in conduit to separate electrical system from communications and data lines.

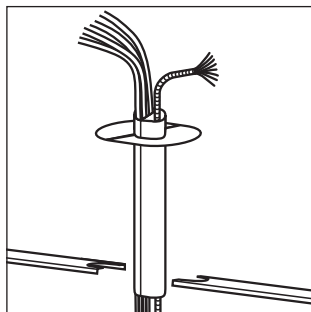

Integrated power and communications poles provide capacity for routing power supply directly through the top of any structural or stacking frame using same width trim/connector kit in place of top cap. Avoid glass or translucent tiles in upper position of frames with integrated power poles. Power pole has a cavity on each side of a center septum. When using a ceiling power in-feed, consider that the in-feed must connect into an electrical harness located in an adjacent panel. (See pages 569-570 for cable capacity.)

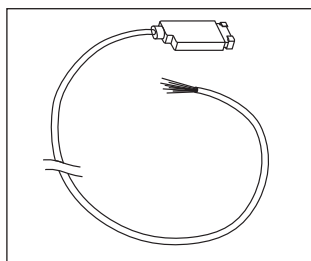

Ceiling power in-feed connects to a prewired electrical harness in the beltline or base pathway, traverses through an adjacent panel and terminates in the junction box at the top of the integrated power pole. For use with integrated power pole models HEP65 and HEP35. No portion of the flex cable can be exposed after installation.

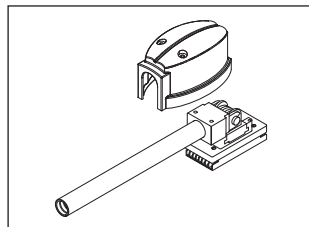

Sealtight base pathway power in-feed attaches to a receptacle opening at the base pathway. A heavy rubber sheathing shields conduit, allowing in-feed to be exposed.

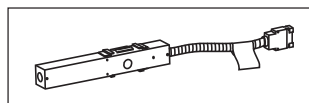

Hardwire (New York Code) power in-feed (model H871400) is used when local electrical codes require hardwire entry. When used in 24"W, 30"W and 36"W panels, power can be routed only in one direction. When used in 42", 48"W and 60"W panels, an electrical pass-thru cable or harness for that panel width can be used to route power back in the opposite direction. Unit must connect to a power or pass-thru harness positioned in the base pathway area of an adjacent panel. Customer to furnish all cabling and wiring from power entry to power source. Junction box can be positioned at any duplex receptacle location.

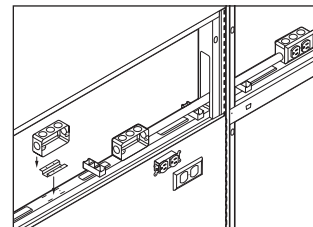

HARDWIRE (CHICAGO CODE) JUNCTION BOX

Wiring harnesses and snap connectors are not allowed in Chicago — base pathways must be comprised of all metallic components. Concealed mounting is the only option at beltline. For the base pathway, junction box (model HH873500) clips directly into receptacle locations. Customer must furnish conduit, wiring, standard duplex receptacles with metal covers for the beltline and designer-type receptacles for the base pathway. Power entry can be routed from the ceiling, via an Abound power pole, or from the floor into a junction box (model HH873500).

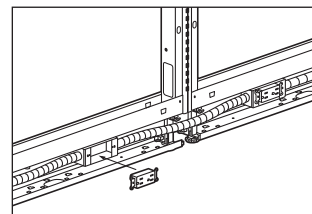

POWER

Power blocks on electrical power harness and pass-thru harness accept duplex receptacles.

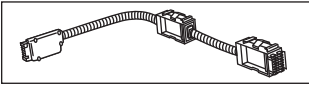

Electrical power harnesses are used to distribute power in panels. Abound electrical can be located at base pathway or beltline only. Connectors at both ends of power harnesses allow power distribution in either direction.

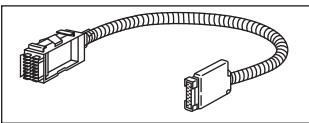

Electrical pass-thru harnesses have capacity to handle one duplex receptacle on each side of the panel when exposed.

A 60" pass-thru harness can be used to jump up to a single duplex receptacle per side at beltline and connecting to a power harness at base pathway.

Electrical power harnesses and pass-thru cables cannot be routed at 90° at beltline once frames are connected to connector blocks.

Electrical pass-thru cables distribute power through any panel where receptacles are not required. Cable length cannot be stretched.

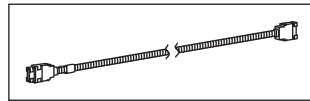

Electrical jumper cables connect power from base pathway or beltline to a harness located on any horizontal member as needed. Jumper cable plugs into power block end of electrical power harness or electrical pass-thru harness.

Model HH871366 is 66" to jump up to 30 inches vertically – base pathway to beltline or beltline to base pathway.

Jumper can also be used from beltline to adjacent beltline at 90° juncture.

POWER BLOCKS

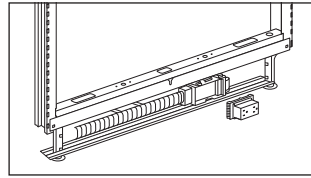

Base pathway mounting: Power blocks snap directly onto brackets in base pathway area.

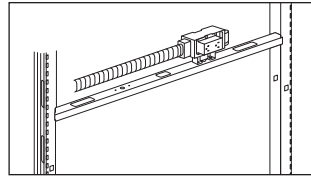

Beltline electrical mounting: For ported receptacles at beltline mount power blocks onto Electrical Mounting Brackets which screw into the panel frame. Electrical Mounting Brackets must be ordered separately. Data/Electrical Port Tiles must be used where exposed receptacles will be located.

RECEPTACLES

Duplex receptacles snap into power blocks of power harnesses or pass-through harnesses. Duplexes are available in multiple colors. Each receptacle is labeled to indicate which circuit it will be connected to.

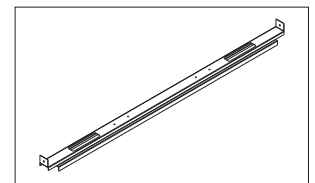
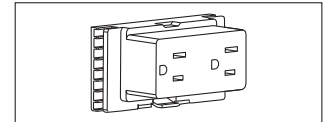

OPTIONAL STIFFENER SUPPORT Stiffener supports can be used to provide additional rigidity to a panel when fabric tiles are on both sides of the frame. May also be used for routing power/data at non-standard heights.

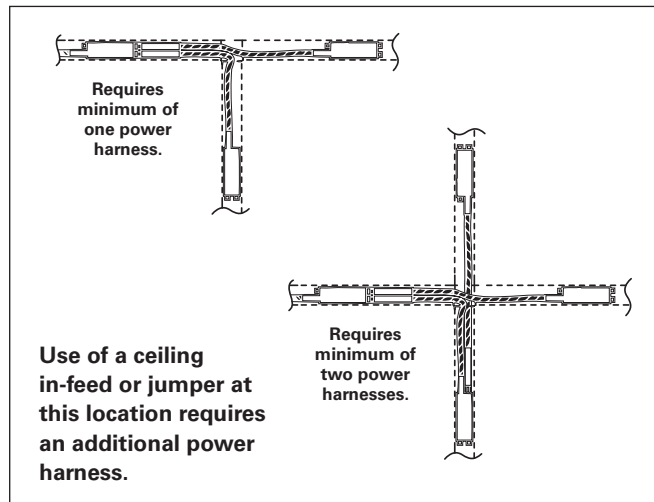

All electrical power harnesses and pass-thru harnesses will stretch 3½", allowing them to span "T" and "X" intersections and "S" extended straight connections.

ACCELERATE® Electrical and Data

Accelerate® features capabilities for cable management, including electrical, voice, and data. The 8-wire electrical system can be integrated at base pathway. See Systems electrical pages 572-577 for electrical models to be used with Accelerate® Systems products. See page 416 for Abound® frame horizontal and vertical wire capacity and page 570 for base pathway capacity.

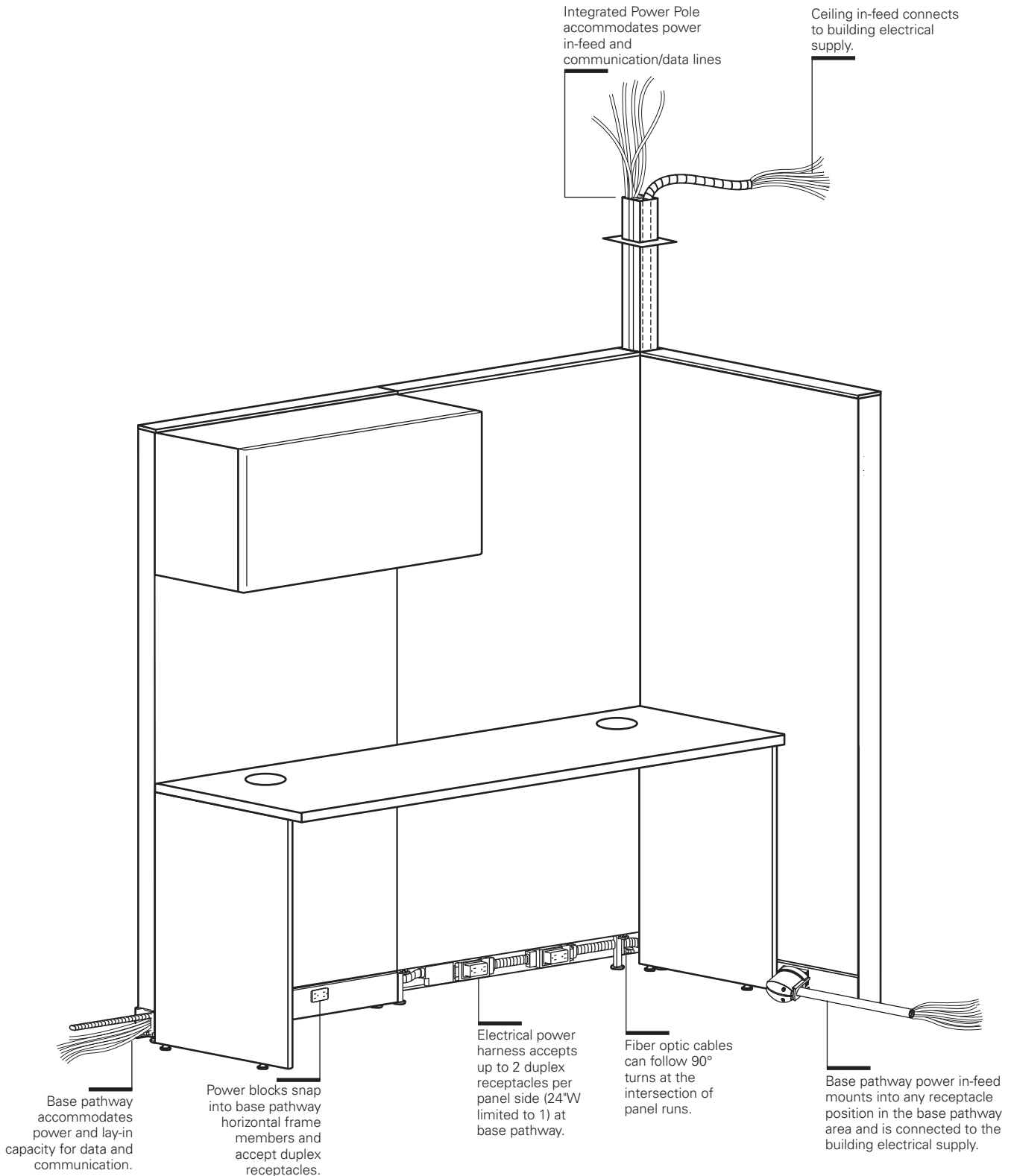

THE ACCELERATE ELECTRICAL SYSTEMS

Accelerate offers a choice of three electrical systems:

- Four-circuit, 3 + 1
- Four-circuit, 2 + 2
- Three-circuit, separate neutrals

All three systems utilize an 8-wire electrical system, rated at 20 amps per circuit (15 amps Canadian). See pages 567-568 for a detailed explanation of each electrical system.

Accelerate panels and electrical components are UL Listed. Electrical components are also CSA certified.

Installation and use of the electrical system, the number of receptacles used on a given circuit and connections to the building power supply should be in compliance with all local and national electrical codes.

Caution: Electrical equipment cords or extension cords MUST NOT BE ROUTED through cable openings in frame sides.

Accelerate's electrical harnesses are UL listed and are considered raceways themselves as defined by the National Electrical Code. This means there is no separation requirement between the electrical harnesses and communications cables per Sec. 800-52 of the National Electrical Code. Communication cables may be placed next to Accelerate's electrical components without a metal septum and will still meet the guidelines of the Telecommunications Industry Association for separation of power and data.

IN-FEEDS

Power in-feed cables deliver power from building to system. In-feed cables are housed in conduit to separate electrical system from communications and data lines.

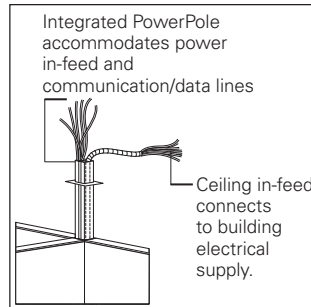

Integrated power and communications poles provide capacity for routing power supply directly through the top of any connector. When using a ceiling power in-feed, consider that the in-feed must connect into an electrical harness located in an adjacent panel. (See pages 569-570 for cable capacity.)

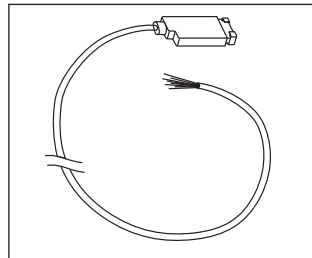

Ceiling power in-feed connects to a prewired electrical harness in the beltline or base pathway, traverses through an adjacent panel and terminates in the junction box at the top of the integrated power pole. For use with integrated power pole models HECPP. No portion of the flex cable can be exposed after installation.

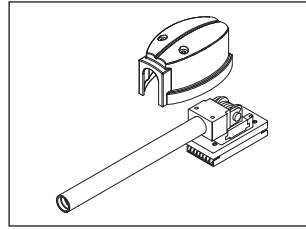

Sealtight base pathway power in-feed attaches to a receptacle opening at the base pathway. A heavy rubber sheathing shields conduit, allowing in-feed to be exposed.

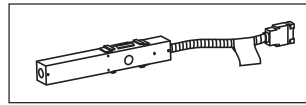

Hardwire (New York Code) power in-feed (model H871400) is used when local electrical codes require hardwire entry. When used in 24"W, 30"W and 36"W panels, power can be routed only in one direction. When used in 42", 48"W and 60"W panels, an electrical pass-thru cable or harness for that panel width can be used to route power back in the opposite direction. Unit must connect to a power or pass-thru harness positioned in the base pathway area of an adjacent panel. Customer to furnish all cabling and wiring from power entry to power source. Junction box can be positioned at any duplex receptacle location.

HARDWARE (CHICAGO CODE) JUNCTION BOX

Wiring harnesses and snap connectors are not allowed in Chicago — base pathways must be comprised of all metallic components. Concealed mounting is the only option at beltline. For the base pathway, junction box (model HH871500) clips directly into receptacle locations. Customer must furnish conduit, wiring, standard duplex receptacles with metal covers for the beltline and designer-type receptacles for the base pathway. Power entry can be routed from the ceiling, via an Accelerate power pole, or from the floor into a junction box (model HH871500). See Systems electrical pages 572-577 for electrical models to be used with Accelerate® Systems products.

DUPLEX RECEPTACLES

For Duplex Receptacle models that can be used on Accelerate® panel systems, please see page 575.

All Systems electrical components can be found on pages 572-577.

SYSTEMS

Electrical and Data

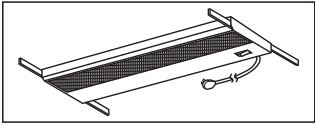

LIGHTING

Task lights can be recessed under storage cabinets or storage shelves.

Task lights in four sizes are available to correspond to cabinet or shelf width. They have 9' power cords in black, connected in the right rear corner. All models feature electronic ballast for longer bulb life and cooler operating temperature. Task lights with a fused plug to meet Chicago electrical code are also available.

Recommendation: Provide a separate circuit for task lights for proper long-term operation without RF interference to computers that may be in use.

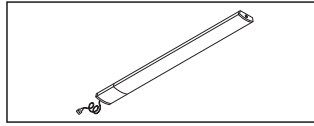

LED TASK LIGHTS

No finish specification required. Attaches magnetically to underside of overhead storage, or attaches with provided screws.

Occupancy sensor attaches to a single or starter LED light and will automatically turn the light off after no motion is detected for 30 minutes.

Just like all the LED light models, the occupancy sensor features a soft-touch on/off switch. LED task lights have a lifetime of 50,000 hours and have a dimmer feature that allows the user to adjust the amount of light output.

Daisy chain options are available. To use the daisy chain application, must start with model HLED17A or HLED31A.

VOICE/DATA RECEPTACLES

Abound not only provides space for large volumes of voice and data cables, it also offers several means of mounting commercially available voice and data components.

Commercially available modular data faceplates can be mounted in vacant base receptacle openings or can be mounted in data/electrical port tiles above or below the worksurface.

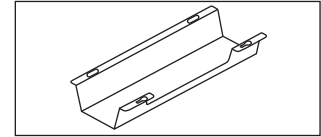

Cable management troughs attach to worksurfaces with provided screws. The graphite metal troughs are designed with cord access cut outs. These cut outs give users access to inside the trough without having to detach it from the worksurface.

SYSTEMS ELECTRICAL SPECIFYING INFORMATION

To Order:

1. Determine which electrical system you will use after consulting your electrician and computer support personnel:
 - **The Four-circuit system (4-Hot/2-Neutral/2-Ground)**
 - 3 + 1 option
 - 2 + 2 option
 - **The Three-circuit system (3-Hot/3-Neutral/2-Ground)**
2. Determine location, quantity and circuit of duplexes.
3. Determine the appropriate choice and use of Isolated, Isolated/Dedicated and Separate Neutral circuits.
4. Specify appropriate Power Harnesses* and Pass-Thru Cables.*
5. Determine the location, quantity and type of Power In-feed needed.

* Select Power Harness models (HH8712XX) and Pass-Thru Cables (HH8711XX) with the last two digits being 1" (or 2") smaller than the associate panel width.

Electrical System Options

The four-circuit, eight-wire electrical system is widely specified and trusted by hundreds of thousands of end-users. This proven system delivers four circuits for every power in-feed in either a 3 + 1 or 2 + 2 configuration. The isolated/dedicated circuits are ideal for sensitive computing equipment, while the common circuits are suitable for faxes, copiers, task lights and other peripherals.

Both the 3 + 1 and 2 + 2 systems use the same pre-wired components, making it easy to adjust as electrical needs change.

You can also choose a three-circuit, eight-wire system that has a dedicated neutral for every hot circuit. The three-circuit components have model numbers with an "A" suffix and appear in a gray box in this pricer.

Four-circuit, 3 + 1 Receptacle Option

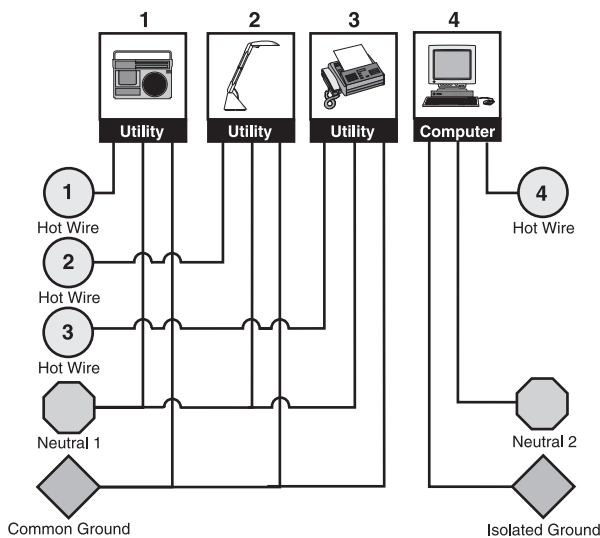

The 3 + 1 option is the electrical standard used by The HON Company for many years in most of their systems products. This wiring option provides three utility circuits plus an isolated/dedicated circuit for more sensitive equipment.

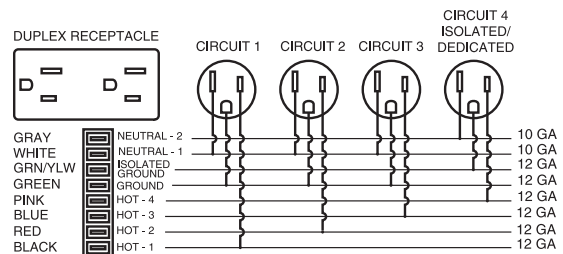

Four-circuit, 2 + 2 Receptacle Option

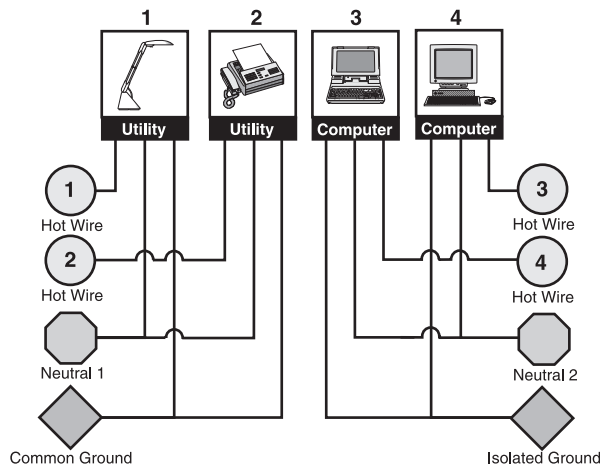

The 2 + 2 option is a wiring option that provides two utility circuits and two isolated circuits for more extensive computer usage applications.

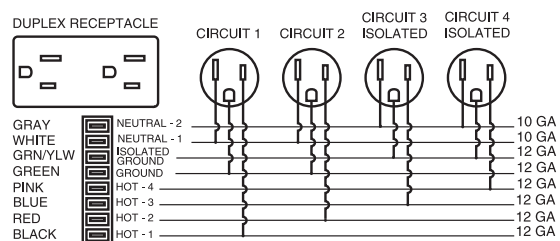

SYSTEMS ELECTRICAL SPECIFYING INFORMATION

Three-circuit, separate neutrals

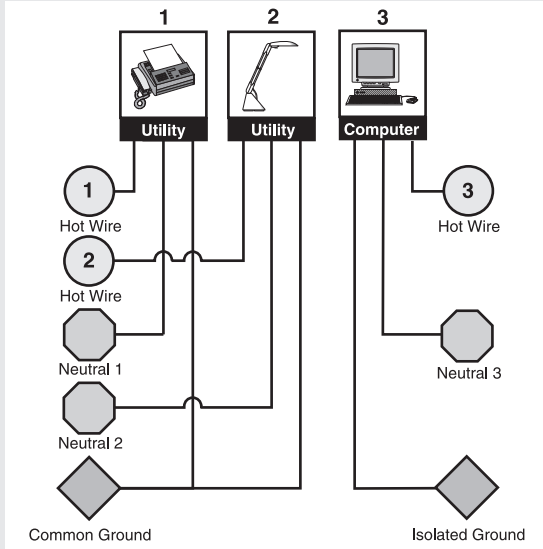

The Three-circuit, separate neutrals configuration is a wiring option that provides separate neutrals for each of the three circuits. Two circuits share a common ground, and one circuit is isolated/dedicated. The three-circuit components have model numbers with an "A" suffix and appear in a gray box in this pricer.

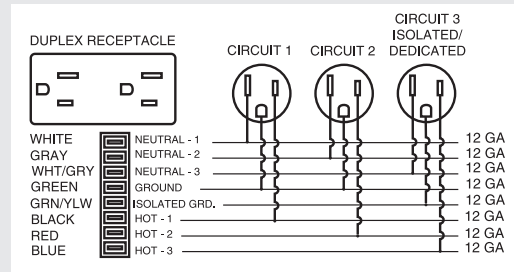

Two 8-wire, 20 AMP (15 AMP Canadian) electrical systems are offered					
Electrical System	Circuitry	Receptacle Capacity			
Four-circuit 4-Hot/2-Neutral/2-Ground (10 gauge neutral wires)	3 + 1	Common Circuit-1 HH873501	Common Circuit-2 (1) HH873502	Common Circuit-3 HH873503	Iso/Dedicated Circuit-4 HH873504
	2 + 2	Common Circuit-1 HH873501	Common Circuit-2 HH873502	Isolated Circuit-3 HH873506	Isolated Circuit-4 HH873504
Three-circuit 3-Hot/3-Neutral/2-Ground (12 gauge neutral wires)	w/separate neutrals	Common Circuit-1 HH873501A	Common Circuit-2 HH873502A	Iso/Dedicated Circuit-3 HH873503A	N/A

Notes:

- Four-circuit components and three-circuit components (with suffix "A") cannot be used together.
- Components of the two systems are keyed differently to prevent components of one system from being connected to components of another system.
- HON Cat. Nos. are printed on the UL labels, and components are color-coded to provide visual identification of the different components.
- Four-circuit components have black plastic parts.
- Three-circuit components have rust-colored terminal ends and receptacle backs are rust colored.

(1) Circuit-2 (one of the 3 common circuits sharing a neutral wire) cannot be used with a single-phase building electrical supply.

Typical power usage by the most commonly specified office equipment.

Source: Industry Analysis, Inc., Rochester, NY

EQUIPMENT	AMPS	EQUIPMENT	AMPS	EQUIPMENT	AMPS
Computers		Copiers		FAX Machines	
Personal Computer	3	Desktop Copier	15	InkJet FAX	less than 1
Notebook Computer	3	Console Copier	20	Thermal FAX	less than 1
		Copier/Duplicator	30	Plain paper FAX	8
Monitors		Printers		Task Lights	
13" Color Monitor	2	Dot Matrix	less than 1	36" T8 Fluorescent	0.2/bulb
17" Color Monitor	3	InkJet	less than 1	48" T8 Fluorescent	0.3/bulb
21" Color Monitor	4	Personal Laser or LED	8		
		Workgroup Laser or LED	15		

Duplex Receptacles



15 AMP Receptacle

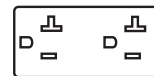

20 AMP Receptacle
(Required by some large copiers.)

SYSTEMS ELECTRICAL SPECIFYING INFORMATION

- Abound and Accelerate panels are UL listed.
- Electrical components are UL Listed and CSA Certified.
- It is the customer's responsibility to ensure that use of the pre-wired electrical system, the number of receptacles used on a given circuit, and connection to a building power source, be in compliance with all local and national electrical codes.
- Contact Customer Service for additional information.
- Pedestals and Lateral Files, positioned under worksurfaces, may render some receptacles inaccessible, and may prohibit use of grommets.
- Four-circuit components and Three-circuit components (with suffix "A") cannot be used together. See pages 567-568.
- Three-way panel connections require at least one power harness.
- 4-way panel connections require at least two power harnesses.
- ! A licensed electrician must make connections to a building electrical supply.

Definition of components:

Electrical Power Harness

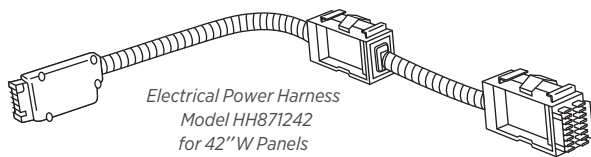

- Used to distribute power in panels.
- Power distribution in either direction.
- Specify Power Harness to match panel width.
- Double-sided: receptacles can be inserted into both sides of Power Blocks.

- ! Three-way panel connections require at least one power harness.
- ! 4-way panel connections require at least two power harnesses.

Electrical Pass-Thru Cables

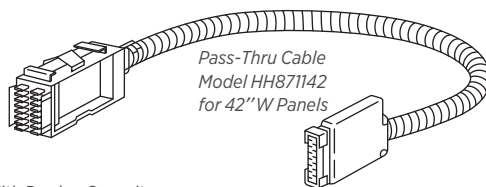

Pass-Thru Cable With Duplex Capacity:

- Use in panels where multiple receptacles are not required.
- Added feature: has capacity for one receptacle on each side of a panel. Feature offers future expansion and is an alternative to Power Harnesses.

Various Electrical Layouts



Straight Line

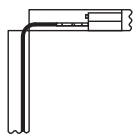

90 Degree Corner

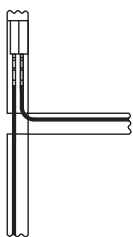

"T" Connection

When ending power in two return panels, wiring pigtails must be returned to original panel run.

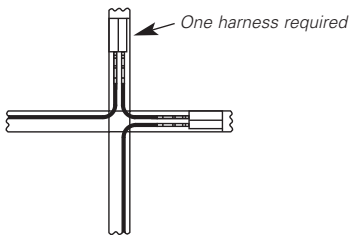

"X" or Cross Connection

To power a 4-way panel connection from one direction, specify at least two double block harnesses.

Duplex Receptacles

- 15 amp outlet configuration.
- Models HH871601 and HH871601A have a 20 amp outlet configuration.
- Fit back-to-back into the Power Block(s) of Power and Pass-Thru Harnesses.
- Labeled with the provided circuit. Circuits connected to the Isolated Ground are identified with an orange triangle; circuits that do not share a neutral or ground have an orange circuit number.

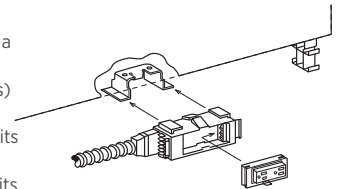

Power In-Feed (Base) Models HH879072 (72") and HH879168 (168")

- Used to connect the panel electrical system to the building electrical supply at a power block.
- Plugs into any receptacle position; can be rotated Left or Right.
- Conduit is UL listed Black Liquid-tight conduit (outside diameter is 7/8").

- ! A licensed electrician must make connections to a building electrical supply.
- ! Must be positioned through a receptacle opening in the baserail cover, prior to an electrician connecting to the power source.

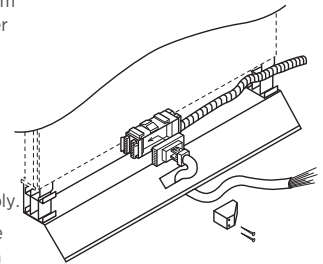

Power In-Feed Model (Ceiling) HH871912 and HH871918

- Used to connect the panel electrical system to the building electrical supply.

- ! A licensed electrician must make connections to a building electrical supply.
- ! Model uses UL recognized flex-cable conduit — no portion can be left exposed (i.e., must be in a power pole).
- ! Power Pole must be ordered separately.



HH871972

Note: In-feed cables listed above may be field-cut to desired length.

Electrical Jumper Cables

- ! When used to connect power between the base pathway and the beltline area, the jumper must be connected to a power block at one end of a run, routed into an adjacent panel that does not contain a power harness, then routed back into the panel containing a power harness or pass-thru cable and connected to a power harness in the other pathway.

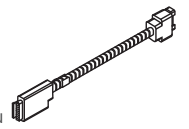

HH871366

Abound Electrical Mounting Brackets

- Use to mount ported receptacles at beltline.
- Screw into the panel frame.
- ! One mounting bracket required at beltline for each 24" W pass-thru or power harness. Two required for 30"-60" W power harness.

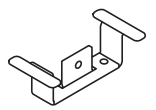

HH8988EBN

WORKING WITH CABLE MANAGEMENT

Base Pathway Receptacle Locations

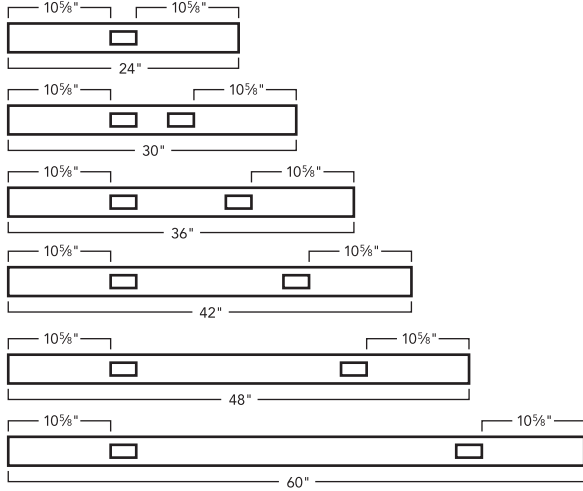

Abound® Lay-in Cable Capacity

The top and base pathway allow continuous voice and data lines to run through and between panels without interruption. Lay-in is provided for environments where systems furniture or cabling are subject to frequent change. All capacities are for Cat 6 cable with a 0.25" diameter.

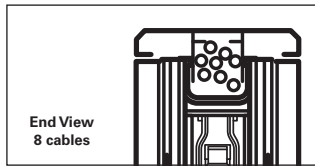

Top pathway accepts up to 8 voice/data cables (.25" dia.).

Abound® Cable Capacity

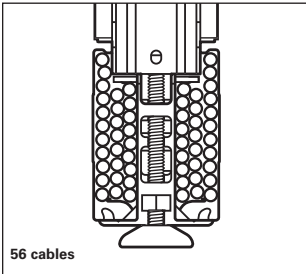

Abound® base pathway accepts up to 56 voice/data cables (.25" dia.) (6.03 sq. in.) at 60% fill.

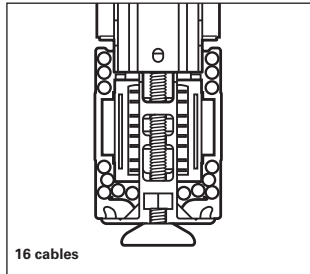

When electrical system shares base pathway, the cable capacity in Abound is reduced to 16 cables (2.25 sq. in.). Cable quantities listed are at 60% fill ratio.

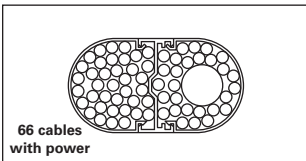

Cable capacity of the power pole, in addition to electrical in-feed is 2.79 sq. in. on one side and 2.91 sq. in. on the other for a total capacity of 66 cables with power of .25" diameter.

Circuit Usage

Strategy 1

Circuits to Equipment

Assign specific uses for each of the circuits:

- For example, in a four-circuit system:
Circuit 1 – Calculators, fans, etc.
Circuit 2 – Task lights (could be wired to wall switch)
Circuit 3 – Computer monitors
Circuit 4 – CPUs

Strategy 2

Circuits to Workstations

Assign specific workstations to each of the three available circuits. Use circuit 4 for power-sensitive electronic equipment.

Placement of pedestals and lateral files may render some duplex locations inaccessible. Pedestal placement may also affect compatibility with pull-up receptacles.

Abound® Lay-In Cable Capacity

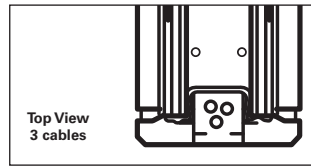

Variable height junctions accept up to 3 voice/data cables (.25" dia.).

Accelerate® Cable Capacity

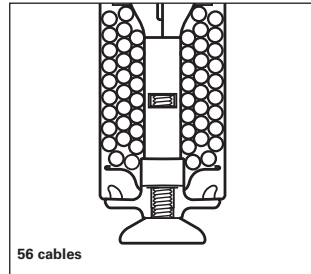

Accelerate® base pathway accepts up to 56 voice/data cables (.25" dia.) (6.27 sq. in.) at 60% fill.

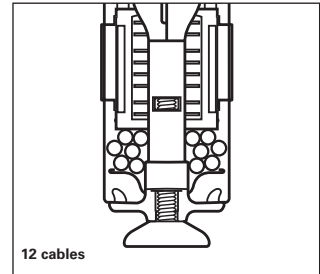

When the electrical system shares the base pathway, the cable capacity in Accelerate® is reduced to 12 cables (.25" dia.) (2.03 sq. in.) at 60% fill ratio.

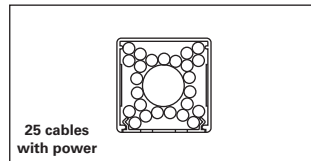

Integrated Power Pole: 2" x 2" overall, 3.3"² interior accommodates a total of 25 cables with power of .25" diameter. Available in two heights: 6'6" or 13', the power pole connects via the universal connector and the overall height is the sum of the connector and the power pole. Constructed of aluminum with a powder coat paint finish in the specified color. Power pole requires a Ceiling In-Feed.

Ceiling In-Feeds: UL

listed as raceways. This means the electrical components are completely shielded and meet any requirements for separation of electrical components and communications cables per Section 800-52 of the National Electrical Code.

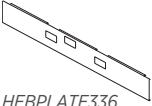
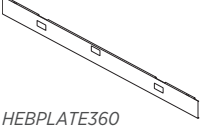
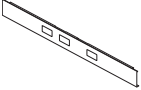
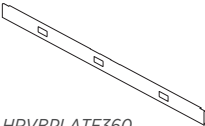

SYSTEMS Electrical Components

	DESCRIPTION	MODEL	SHIP WEIGHT	CUBE	LIST PRICE BY PAINT GRADE	
					P1	P2
 HEBPLATE336  HEBPLATE360	Accelerate® Base Pathway Cover w/Additional Knockout					
	36"W	HEBPLATE336	7	0.4	\$74	\$84
	42"W	HEBPLATE342	8	0.4	\$76	\$86
	48"W	HEBPLATE348	9	0.4	\$79	\$89
	60"W	HEBPLATE360	11	0.5	\$90	\$100
	72"W	HEBPLATE372	14	0.6	\$100	\$110
	NOTES: Specify paint, see page 455. SPECIFYING EXAMPLE: HEBPLATE336.T4					
 HRVBPLATE336  HRVBPLATE360	Abound® Base Pathway Cover w/Additional Knockout					
	36"W	HRVBPLATE336	7	0.4	\$73	\$83
	42"W	HRVBPLATE342	8	0.4	\$75	\$85
	48"W	HRVBPLATE348	9	0.4	\$78	\$88
	60"W	HRVBPLATE360	11	0.5	\$89	\$99
	NOTES: Specify paint, see page 395. SPECIFYING EXAMPLE: HRVBPLATE336.T4					

NOTES:

- Specify Pathways to match trim color.
- Standard raceways with two knockouts are standard on panels. If additional three knockout kickplate is ordered, the two port version can be saved or discarded.

HOW TO SPECIFY

<p>Select Model Number</p> <p>H E B P L A T E 3 3 6 .</p>	<p>Select Paint Color</p> <p>See page 455</p> <p>T 4</p>
---	--

SYSTEMS

Electrical Components

GSA SIN 33721



Icon Legend on page 19

WORKSTATIONS

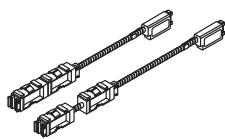

DESCRIPTION	MAX. RECEPT. CAP. PER PANEL SIDE	MODEL		SHIP WEIGHT	CUBE	LIST PRICE
		FOUR-CIRCUIT 3 + 1 2 + 2	THREE-CIRCUIT, SEPARATE NEUTRALS			
Electrical Power Harnesses, Frames — w/duplex capacity						
For 24"W	1	HH871224	HH871224A	2.0	0.5	\$206
For 30"W	2	HH871230	HH871230A	2.0	0.5	\$206
For 36"W	2	HH871236	HH871236A	2.5	0.5	\$206
For 42"W	2	HH871242	HH871242A	3.0	0.5	\$216
For 48"W	2	HH871248	HH871248A	3.0	0.5	\$216
For 60"W	2	HH871260	HH871260A	3.0	0.5	\$216
For 72"W (for use with Accelerate® 72"W panels only)	2	HH871272	HH871272A	5.0	0.5	\$216

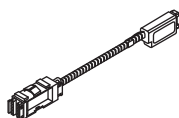

Electrical Pass-Thru Cables, Frames — w/duplex capacity						
For 24"W	1	HH871124	HH871124A	2.0	0.5	\$129
For 30"W	1	HH871130	HH871130A	2.0	0.5	\$129
For 36"W	1	HH871136	HH871136A	2.0	0.5	\$129
For 42"W	1	HH871142	HH871142A	2.5	0.5	\$136
For 48"W	1	HH871148	HH871148A	2.5	0.5	\$136
For 60"W	1	HH871160	HH871160A	3.0	0.5	\$136
For 72"W (for use with Accelerate® 72"W panels only)	1	HH871172	HH871172A	5.0	0.5	\$136

NOTES: For use when data will be terminated in one cutout in the panel.

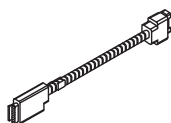

Electrical Pass-Thru Harness without Power Block						
For 24"W Frames	0	HH871024	HH871024A	2.0	0.5	\$119
For 30"W Frames	0	HH871030	HH871030A	2.0	0.5	\$119
For 36"W Frames	0	HH871036	HH871036A	2.0	0.5	\$119
For 42"W Frames	0	HH871042	HH871042A	3.0	0.5	\$124
For 48"W Frames	0	HH871048	HH871048A	3.0	0.5	\$124
For 60"W Frames	0	HH871060	HH871060A	3.0	0.5	\$124
For 72"W Frame Runs	0	HH871072		4.0	0.5	\$171

NOTES:

- Duplex receptacles on page 575.
- Electric harnesses are intended for use with HON Systems furniture and are approved under GSA SIN 33721. When purchased separately and used without HON Systems furniture, the models are considered Open Market.
- ! Four-circuit components and three-circuit components (with "A" suffix) not designed to be used together. See pages 567-568.

HOW TO SPECIFY

<p>Select Model Number</p> <p>HH871048 . P</p>	<p>Select Color</p> <p>See page 455</p>
--	---

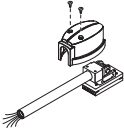
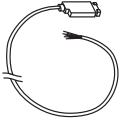
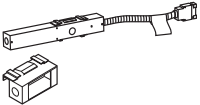

SYSTEMS Electrical Components

DESCRIPTION	MODEL		SHIP WEIGHT	CUBE	LIST PRICE
	FOUR-CIRCUIT 3 + 1 2 + 2	THREE-CIRCUIT, SEPARATE NEUTRALS			
 <p>Electrical Jumper Cables Jumper for up to 36" vertical jump, 66" long</p>	HH871366	HH871366A	3.0	0.5	\$139
 <p>Power In-Feed Cables — Base In-Feed 72" long conduit, Sealtight Cable — 7/8" diameter 168" long conduit, Sealtight Cable — 7/8" diameter</p>	HH879072 ⓘ HH879168	HH879072A HH879168A	4.5 9.0	0.3 0.4	\$229 \$534
 <p>Ceiling In-Feed 144" long conduit, Flex Cable — 7/8" dia. 216" long conduit, Flex Cable — 7/8" dia.</p> <p>ⓘ Must be used with Power Pole. Power in-feed models HH871912 and HH871918 plug into the end of any power block. No portion of the cable can be exposed after installation.</p>	HH871912 ⓘ HH871918	HH871912A HH871918A	4.0 4.0	0.5 0.5	\$238 \$310
 <p>Hardwire Applications Hardwire Power In-feed</p> <p>ⓘ Customer to furnish all cabling and wiring from power entry to power source (approved for use by city of New York).</p> <p>Hardwire Junction Box (6-pack)</p> <p>ⓘ For use with Accelerate® and Abound® Beltline only. ⓘ Hardwire Junction Boxes cannot be installed back-to-back in panel applications.</p> <p>Hardwire Junction Box (6-pack)</p> <p>ⓘ For use with Abound® Raceway panels only.</p> <p>NOTES: Junction Box can be positioned at any Duplex Receptacle location in 30"W or wider panels. ⓘ Contact Tailored Solutions for back-to-back Junction Box standard special number.</p>	HH871400 ⓘ HH871500 ⓘ HH873500	HH871400A	4.0	0.3 0.1 0.2	\$224 \$477 \$446

NOTES:

- Duplex receptacles on page 575.
- ⓘ Four-circuit components and three-circuit components (with "A" suffix) not designed to be used together. See pages 567-568.
- ⓘ To connect power between the base pathway and the beltline area on Abound, four-circuit jumper cables (H8713xx) must be connected to a power block at one end of a run, routed into an adjacent panel that contains no power harness, then routed back into the panel that contains a power harness (or pass-thru cable), and connected to a power harness in the other pathway.

HOW TO SPECIFY

<p>Select Model Number</p> <p>HH871366 .</p>	<p>Select Color</p> <p>See page 455</p> <p>P</p>
--	--

SYSTEMS

Electrical Components

GSA SIN 33721



Icon Legend on page 19

WORKSTATIONS



DESCRIPTION	MODEL	SHIP WEIGHT	CUBE	LIST PRICE BY PAINT GRADE
				P1
Abound® Integrated Power Pole For 35"H-50"H Frames. Poles are 78"H. For 65"H-95"H Frames. Poles are 52"H. NOTES: Power Pole includes ceiling trim piece.	HEP35	9 Ⓢ	0.6	\$383
	HEP65	6 Ⓢ	0.4	\$270

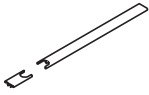

DESCRIPTION	MODEL	SHIP WEIGHT	CUBE	LIST PRICE
Power Pole Trim Kit (Abound® only) 24"W 30"W 36"W 42"W 48"W 60"W	HRVP24P HRVP30P HRVP36P HRVP42P HRVP48P HRVP60P	2 Ⓢ 3 Ⓢ 4 Ⓢ 5 Ⓢ 6 Ⓢ 7 Ⓢ	0.3 0.4 0.5 0.5 0.6 0.7	\$134 \$142 \$149 \$152 \$157 \$166



DESCRIPTION	MODEL	SHIP WEIGHT	CUBE	LIST PRICE
Power Pole — w/o Receptacles (Voi® only) 10'5" • Used for routing In-Feed Cable from ceiling to panel baserail. Double cavity, plus conduit of In-Feed Cable serves as the division of electrical and communications cabling.	HH870070	14	0.5	\$433

Specify paint color for HH870070, not available in Putty



DESCRIPTION	MODEL	SHIP WEIGHT	CUBE	LIST PRICE BY PAINT GRADE		
				P1	P2	P3
Accelerate® Integrated Power Pole 78"H x 2"W x 2"D 156"H x 2"W x 2"D	HECPP Ⓢ	14 Ⓢ	0.5	\$276	\$296	\$298
	HECPP156	28 Ⓢ	1.0	\$668	\$688	\$690

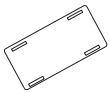

DESCRIPTION	MODEL	SHIP WEIGHT	CUBE	LIST PRICE
Receptacle Cover Replacements Quantity 25 ⚠ For use with Accelerate® panels only. ⚠ Specify Color — Available in Black (P), Muslin (T3) and Shadow (SHDW) only.	HEREPCVR	1 Ⓢ	0.1	\$74

HOW TO SPECIFY

Select Model Number H R V P 2 4 P .	Select Paint Color See page 455 T 4
--	---



SYSTEMS Electrical Components



Each marked with Circuit Number

DESCRIPTION	MODEL		SHIP WEIGHT	CUBE	LIST PRICE
	FOUR-CIRCUIT	THREE-CIRCUIT,			
	3 + 1 2 + 2	SEPARATE NEUTRALS			
Abound® Duplex Receptacles					
Circuit 1	HH873501	HH873501A	0.5	0.1	\$42
Circuit 2	HH873502	HH873502A	0.5	0.1	\$42
Circuit 3	HH873503	HH873503A	0.5	0.1	\$42
Circuit 4 — isolated, dedicated circuit	HH873504		0.5	0.1	\$42
Circuit 1 — 20 amp outlet	HH871601	HH871601A	1.0	0.1	\$42
Circuit 3 (2 + 2)	HH873506		0.5	0.1	\$42

Specify color.

❗ Duplex receptacle models above are for use with Abound® models only.



Each marked with Circuit Number

DESCRIPTION	MODEL		SHIP WEIGHT	CUBE	CORE LIST PRICE
	FOUR-CIRCUIT	THREE-CIRCUIT,			
	3 + 1 2 + 2	SEPARATE NEUTRALS			
Accelerate® Duplex Receptacles					
Circuit 1	HH871501 ☉	HH871501A	1.0	0.5	\$42
Circuit 2	HH871502 ☉	HH871502A	1.0	0.5	\$42
Circuit 3 (except 2 + 2 — see below)	HH871503 ☉	HH871503A	1.0	0.5	\$42
Circuit 4 — isolated, dedicated circuit	HH871504		1.0	0.5	\$42
Circuit 1 (20 amp outlet configuration)	HH871601		1.0	0.5	\$42
Circuit 3 (2 + 2)	HH871506		1.0	0.5	\$42

Specify Paint.

NOTES: Use with Accelerate® models.

SPECIFYING EXAMPLE: HH871501.S

See page 455 for color options.



DESCRIPTION	MODEL		SHIP WEIGHT	CUBE	LIST PRICE
	FOUR-CIRCUIT	THREE-CIRCUIT,			
	3 + 1 2 + 2	SEPARATE NEUTRALS			
Data/Electrical Port Kit					
Specify color	HHT2DP		1.0	0.1	\$25

NOTES:

- Data/Electrical Port Kit used for field installations of additional data accessories.
- ❗ Four-circuit components and three-circuit components (with "A" suffix) not designed to be used together. See pages 567-568.

Maximum Receptacle Capacity in Abound Panel Base Raceways

Widths	24	30	36	42	48	60
Maximum of 1 duplex per panel side	X					
Maximum of 2 duplexes per panel side		X	X	X	X	X

Duplex Color Recommended to Coordinate with Paint Color			
Paint Color	Paint Code	Duplex Color	Duplex Code
Black	P	Black	P
Brownstone	P7D	Brownstone	EY
Charcoal	S	Charcoal	S
Designer White	PJW	Designer White	DW
Fossil	P28	Charcoal	S
Greige	T5	Muslin	T3
Light Gray	Q	Loft	LOFT
Loft	LOFT	Loft	LOFT
Muslin	T3	Muslin	T3
Putty	L	Black	P
Shadow	SHDW	Muslin	T3
Silver	PR6	Titanium	TI
Titanium	P8T	Titanium	TI
Champagne Metallic	T4	Muslin	T3
Platinum Metallic	T1	Titanium	TI

Data / Electrical Port Kit Color Recommended to Coordinate with Paint Color			
Paint Color	Paint Code	Data / Port Kit Color	Data / Port Kit Code
Black	P	Black	P
Brownstone	P7D	Brownstone	EY
Charcoal	S	Charcoal	S
Designer White	PJW	Designer White	DW
Fossil	P28	Charcoal	S
Greige	T5	Muslin	T3
Light Gray	Q	Loft	LOFT
Loft	LOFT	Loft	LOFT
Muslin	T3	Muslin	T3
Putty	L	Black	P
Shadow	SHDW	Muslin	T2
Silver	PR6	Titanium	TI
Titanium	P8T	Titanium	TI
Champagne Metallic	T4	Muslin	T3
Platinum Metallic	T1	Titanium	TI

HOW TO SPECIFY

<p>Select Model Number</p> <p>HH873501 .</p>	<p>Select Color</p> <p>See page 455</p> <p>P</p>
--	--

SYSTEMS

Electrical Components

GSA SIN 33721 EXCEPT AS NOTED



Icon Legend on page 19

WORKSTATIONS

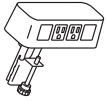

DESCRIPTION

Power & Data Center

2 Receptacles 2 Data Accessory

- Standard with two receptacles and openings for two data ports.
- 6' power cord with standard three-prong plug.
- Fits on any worksurface with a 4" overhang.
- UL Listed.

NOTES: Cable ports accommodate up to four individual voice and data outlets, and can be mounted anywhere there is an electrical receptacle opening. Data/Electrical Port Kit used for field installations of additional data accessories.

- ⚠ Four-circuit components and three-circuit components (with "A" suffix) not designed to be used together. See pages 567-568.
- ⚠ Duplex receptacle models shown on the previous page are for use with Abound® models only.
- ⚠ Color finish coordinates with HON's Loft. *Specify LOFT when ordering. Example: HCOMDOME2.LOFT*

MODEL

HCOMDOME2

SHIP WEIGHT

2.5 Ⓢ

CUBE

0.2

LIST PRICE

\$296

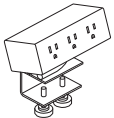

Model HPWRMOD3WC shown

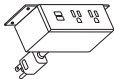

Model HPWRMOD2UWM shown

Power Modules

3 Receptacles with Worksurface Clamp

3 Receptacles with Under-Worksurface Mounting Bracket

2 Receptacles 2 USB with Worksurface Clamp

2 Receptacles 2 USB with Under-Worksurface Mounting Bracket

- 6' power cord with standard three-prong plug.
- Under-worksurface mounting bracket models work with any top that has a 5" x 5" square clearance.
- Worksurface clamp models work on any top with a 4" overhang.
- UL Listed.

NOTES: Cable ports accommodate up to four individual voice and data outlets, and can be mounted anywhere there is an electrical receptacle opening. Data/Electrical Port Kit used for field installations of additional data accessories.

- ⚠ Four-circuit components and three-circuit components (with "A" suffix) not designed to be used together. See pages 567-568.
- ⚠ Duplex receptacle models shown on the previous page are for use with Abound® models only.
- ⚠ Color finish coordinates with HON's Charcoal or White. *Specify STRM for Storm and SNW for Snow when ordering. Example: HPWRMOD3WC.STRM*

HPWRMOD3WC Ⓢ

2.3 Ⓢ

0.2

\$310

HPWRMOD3UWM

2.3 Ⓢ

0.2

\$310

HPWRMOD2WC Ⓢ

2.3 Ⓢ

0.2

\$496

HPWRMOD2UWM

2.3 Ⓢ

0.2

\$496



Vertebrae

NOTES: 30"H x 3 1/8"W x 1 1/2"D. Ships unassembled.

- ⚠ Clear finish. Specify "X" for finish option.
- SPECIFYING EXAMPLE: HMPVWM28.X**

HMPVWM28

3.0

0.3

\$223

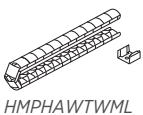

HMPHAWTWML



HMPHATFWML

Wire Managers for Height Adjustable

Workstation to Trough

Trough to Floor

- ⚠ Wire Manager Workstation to Trough only available in black.
- ⚠ HMPHATFWML Trough to Floor cable manager is 3" x 1 1/2".

HMPHAWTWML Ⓢ

3.0

0.1

\$267

HMPHATFWML

2.0

0.3

\$251

OPEN MARKET

NOTES:

- For additional information see the Workplace Tools section in the 2021 Shared Spaces Pricer.

HOW TO SPECIFY

Select Model Number

H C O M D O M E 2 .



Select Color

See page 455

L O F T

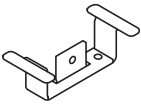
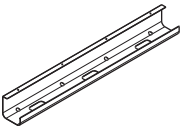
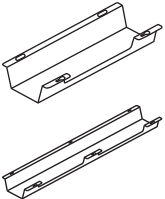
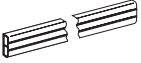
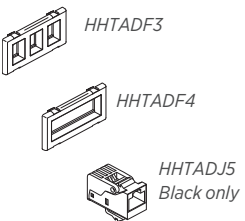
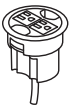

Icon Legend on page 19

	DESCRIPTION	MODEL	SHIP WEIGHT	CUBE	LIST PRICE
	<p>Abound Electrical Mounting Brackets (pack of 12)</p> <p>⚠ 1 bracket required at beltline for each pass-thru harness and 24"W power harness and 2 for 30"-60"W power harness.</p> <p>⚠ Bracket for use at beltline only. Dimension of raceway mounting bracket is different and not interchangeable. Bracket height for beltline changed Q1 2019.</p> <p>⚠ If adding onto product produced prior to Q1 2019, please contact HON Customer Support.</p>	HH8988EBN	3.0 Ⓢ	0.1	\$63
	<p>Cable Management Tray</p> <p>24"</p> <p>36"</p>	<p>HHCMT24</p> <p>HHCMT36</p>	<p>2.0 Ⓢ</p> <p>3.0 Ⓢ</p>	<p>0.3</p> <p>0.4</p>	<p>\$74</p> <p>\$91</p>
<i>Black only</i>					
	<p>Cable Management Troughs</p> <p>17"W – Single</p> <p>17"W – 10-Pack</p> <p>36"W – Single</p> <p>36"W – 10-Pack</p> <ul style="list-style-type: none"> • Cable management troughs ship flat packed. • The troughs attach to underneath the worksurface with screws. • The 17"W has one wire access cut out on the user side. The 36" has two wire access cut outs. These cut outs give users access to inside the trough without having to detach it from the worksurface. • Color: Graphite. • Material: Metal. • TAA Compliant. • Slim profile design. 	<p>HCTROUGH17</p> <p>HCTROUGH1710</p> <p>HCTROUGH36</p> <p>HCTROUGH3610</p>	<p>2.7 Ⓢ</p> <p>14.0 Ⓢ</p> <p>4.9 Ⓢ</p> <p>30.0 Ⓢ</p>	<p>0.5</p> <p>0.5</p> <p>0.9</p> <p>0.9</p>	<p>\$67</p> <p>\$620</p> <p>\$113</p> <p>\$1045</p>
	<p>NOTES: For additional information see the Workplace Tools section in the 2021 Shared Spaces Pricer.</p>				
	<p>Wire Manager</p> <ul style="list-style-type: none"> • HHEM model clips to bottom of panels. (62"W) • Slits in wire manager allows cable to be passed into unit. 	HHEM620	10.0 Ⓢ	0.5	\$104
<i>Black only</i>					
	<p>AMP Data Faceplates</p> <p>Three-port flex-mode faceplate</p> <p>Four-port flex-mode faceplate</p> <p>⚠ Data faceplates available in Black (E4) only.</p> <p>AMP RJ45 CAT 5E Jack – Black (P)</p> <p>AMP RJ45 CAT 6 Jack – Black (P)</p> <p>Models HHTADJ5 and HHTADJ6 snap into faceplate.</p>	<p>HHTADF3</p> <p>HHTADF4 Ⓢ</p> <p>HHTADJ5 Ⓢ</p> <p>HHTADJ6 Ⓢ</p>	<p>1.0 Ⓢ</p> <p>1.0 Ⓢ</p> <p>1.0 Ⓢ</p> <p>1.0 Ⓢ</p>	<p>0.2</p> <p>0.2</p> <p>0.1</p> <p>0.1</p>	<p>\$26</p> <p>\$26</p> <p>\$42</p> <p>\$57</p>
	<p>NOTES: AMP Data Faceplates attach to bottom of panel or at worksurface height in front of baserail covers for easy cable routing. Faceplates cannot be installed back-to-back in a panel application.</p>				
	<p>Power Hub, 3" Grommet Mount, 6' Cord</p> <ul style="list-style-type: none"> • Fits in 3" round grommet holes on the following product lines: Coordinate, Huddle, Motivate, all laminate and veneer casegoods series, and Systems Worksurfaces. • Two grounded AC power outlets. • Includes 6' cord with three-prong plug. • Field installed with Plug-and-play ease. 	HGRMTAC	1.3	0.2	\$116
SIN 33721T	<p>NOTES: For additional information see the Workplace Tools section in the 2021 Shared Spaces Pricer.</p> <p>⚠ Available in black only (no color designation so use .X – Specify: HGRMTAC.X).</p>				
	<p>Power/USB Hub, 3" Grommet Mount</p> <ul style="list-style-type: none"> • One grounded AC power outlet with 2 USB ports. • UL Listed. 	HGRMTUSB2	1.3 Ⓢ	0.2	\$226
SIN 33721T	<p>NOTES: For additional information see the Workplace Tools section in the 2021 Shared Spaces Pricer.</p> <p>⚠ Available in black only (no color designation so use .X – Specify: HGRMTUSB2.X).</p>				

SYSTEMS

Working with Worksurfaces and Supports

Worksurfaces are 1/8" thick with particle-board core and with top surfaces finished in high-pressure laminate. Bottom surfaces are covered with a backer sheet.

Worksurface bracket kits support worksurface by attaching to an adjacent return panel the same width as the worksurface depth. Brackets allow one end of a worksurface to be supported by a panel return.



Cantilever brackets can be inserted into panel reveals in 1" vertical increments. Left or right handed. One size is used for both 24"D and 30"D worksurfaces. 18" Cantilever brackets are used for 18"D worksurfaces. DO NOT USE cantilever brackets at the end of a worksurface where no return panel is positioned or in worksurface runs longer than 72"W.

Wire management grommets are standard in most worksurfaces (unless "no grommet" worksurfaces selected).

Corner worksurfaces optimize use of space, and provide a convenient location for computer and monitor.

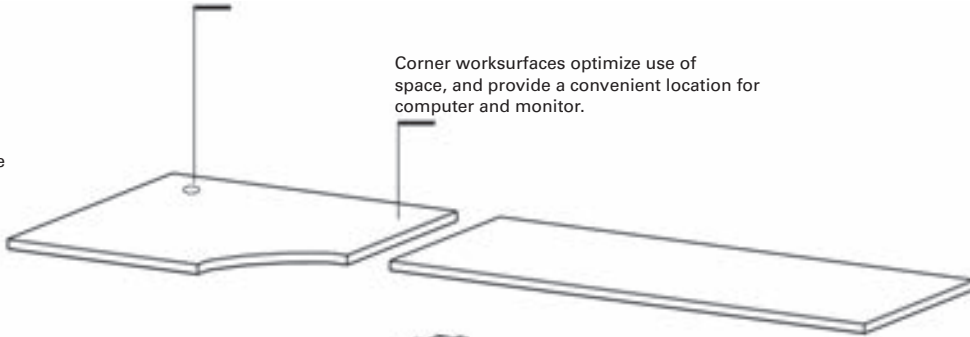

Flat brackets can be used to connect one worksurface perpendicular to another worksurface.

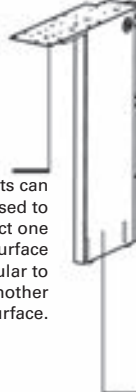

End-panel supports are used at the end of a run when no return panel is present. Straight worksurfaces adjacent to 120° connections must be supported by full end panels. Leveling glides provide 2 3/4" of adjustment.



Support legs are used to support worksurfaces only in a shared position.

Primary worksurfaces are available in 18", 24" and 30" depths. Nominal worksurface width is equal to nominal panel width. Other support hardware is ordered separately.

Corner worksurfaces with woodgrain laminate have grain direction diagonal to adjacent worksurfaces. One rear center support bracket is included. All other support hardware is ordered separately.

Wire management grommets are standard in most worksurfaces. Worksurfaces less than 48"W have one grommet centered on edge of worksurface. Rectangular worksurfaces over 42"W have two grommets. Peninsulas have one grommet. Corner Worksurfaces have one grommet (one on each back edge). D-Shaped worksurfaces and countertops do not have grommets.

Edgeband is available on laminate tops in standard colors (customer specified) to match or complement solid, patterned, or woodgrain laminates.

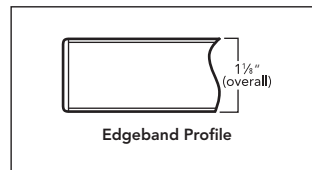

Working with Worksurfaces and Supports

Optional width worksurfaces are available for use with panel runs having a TEE or Extended Straight connection.

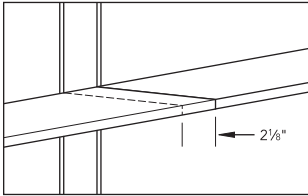

Worksurfaces can be configured at 29 1/2" with end-panel supports and support legs, or at various heights on 1" increments using specific product configurations.

Worksurface support options include:

- Open leg models
- Support column
- Flat brackets
- Worksurface bracket kit
- Cantilever bracket
- Universal support leg
- End-panel support
- Freestanding pedestal

Other worksurface supports include:

- Support columns
- External channel supports
- Support pedestals
- Pedestals with panel-to-pedestal bracket
- Desking freestanding shared leg

Support Guidelines:

- Unsupported panel runs greater than 72"W need floor support for improved stability.
- Worksurface bracket kit should be used to tie panels to worksurfaces for added stability.
- A panel run without a return needs a floor support.
- Unsupported worksurface spans of 60"W-84"W require an external worksurface support channel. It is recommended for 48"W-60"W.
- Cantilevers only to be used on worksurface runs 48"W or less.

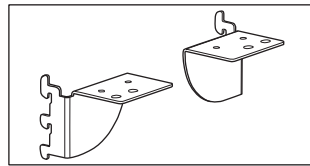

Worksurface bracket kit allows one end of a worksurface to be supported by a return panel. Return panel width must be the same as the depth of the worksurface.

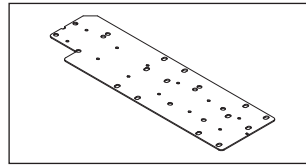

Flat brackets can be used to connect one worksurface perpendicular to another worksurface.

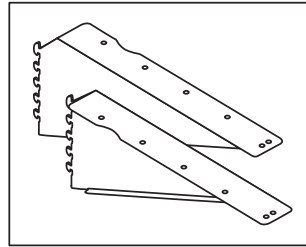

Cantilever brackets are left or right handed. They can be inserted into panel reveals in 1" vertical increments. One size is used for both 24" and 30"D worksurfaces. 18" Cantilever brackets are used for 18"D worksurfaces. Both left and right brackets are required in shared applications.

Important: Do not use cantilever brackets at the end of a worksurface where no 90° return panel is positioned.

- Do not use to support worksurfaces from which a hanging pedestal is suspended, or which a peninsula worksurface is attached.
- Do not use to support worksurfaces supported with permanent wall hanger kit.

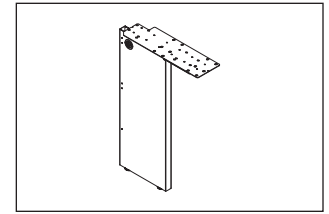

Universal support legs are used to support worksurfaces only in a shared position.

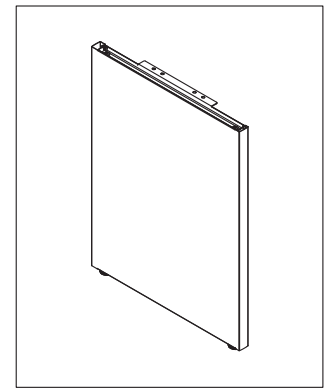

End-panel supports are used in place of return panels at the end of worksurface runs. Straight worksurfaces adjacent to 120° connections must be supported by full end panels. End-panel supports are ordered for right- or left-handed application. Leveling glides provide 1/2" of adjustment.

SYSTEMS

Working with Worksurfaces and Supports

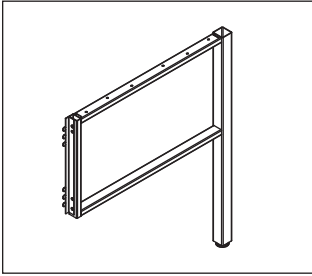

Open Leg models are used to support various worksurface configurations and include attaching hardware and leveling glides.

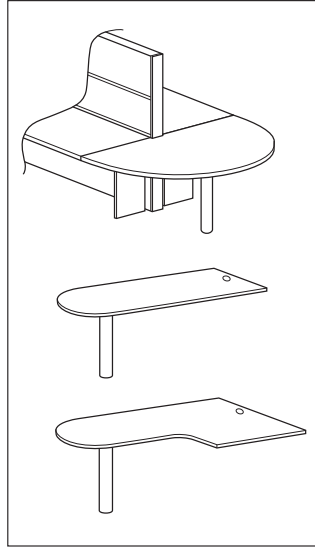

D-Shaped, Peninsula and Jetty worksurfaces require support columns (ordered separately).

Countertops are available in straight or corner configurations.

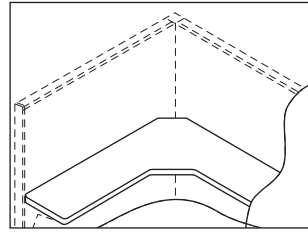

Corner shelves are available in Edgeband. Attachment brackets are included.

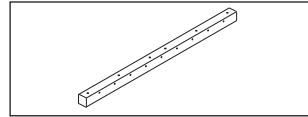

- Unsupported worksurface spans of 60"W-84"W require an external worksurface support channel. It is recommended for 48"W-60"W.

EXTERNAL CHANNEL SELECTION GUIDE

Support Combination		Rectangle Worksurface Width			
		Recommended		Required	
Worksurface End Support 1	Worksurface End Support 2	54	60	66	72
End Panel	End Panel	42"	48"	54"	60"
End Panel	Pedestal	NA	NA	NA	42"
End Panel	Worksurface Brackets	42"	48"	54"	60"
End Panel	Cantilever	42"	48"	54"	60"
End Panel	Open Leg	42"	48"	54"	60"
Pedestal	Pedestal	NA	NA	NA	NA
Pedestal	Worksurface Brackets	NA	NA	NA	42"
Pedestal	Cantilever	NA	NA	NA	42"
Pedestal	Open Leg	NA	NA	NA	42"
Worksurface Brackets	Worksurface Brackets	42"	48"	54"	60"
Worksurface Brackets	Cantilever	42"	48"	54"	60"
Worksurface Brackets	Open Leg	42"	48"	54"	60"

See page 189 for External Channel models.

Supports above are recommended for worksurfaces 54"W or 60"W. For 66"-72" worksurfaces, the supports are required.



SYSTEMS WORKSURFACES

Primary

DESCRIPTION	MODEL	SHIP WEIGHT	CUBE	L1	L2
				LIST PRICE	LIST PRICE
Primary and/or Return Worksurfaces					
24"W x 18"D	HWR1824P	23	2.1	\$299	\$309
30"W x 18"D	HWR1830P	28	2.1	\$310	\$320
36"W x 18"D	HWR1836P	35	2.5	\$321	\$331
42"W x 18"D	HWR1842P	39	2.8	\$332	\$342
48"W x 18"D	HWR1848P	44	3.2	\$368	\$378
54"W x 18"D	HWR1854P	48	4.0	\$409	\$424
60"W x 18"D	HWR1860P	53	4.0	\$420	\$435
66"W x 18"D	HWR1866P	65	4.7	\$450	\$465
72"W x 18"D	HWR1872P	67	4.7	\$462	\$477
24"W x 24"D	HWR2424P	31	2.2	\$306	\$316
30"W x 24"D	HWR2430P ☉	37	2.2	\$320	\$330
36"W x 24"D	HWR2436P ☉	46	2.5	\$346	\$361
42"W x 24"D	HWR2442P	52	2.5	\$380	\$395
48"W x 24"D	HWR2448P ☉	58	3.3	\$404	\$419
54"W x 24"D	HWR2454P	64	4.0	\$429	\$449
60"W x 24"D	HWR2460P ☉	70	4.0	\$477	\$497
66"W x 24"D	HWR2466P	86	4.8	\$513	\$533
72"W x 24"D	HWR2472P ☉	89	4.8	\$529	\$549
84"W x 24"D	HWR2484P	103	5.1	\$750	\$775

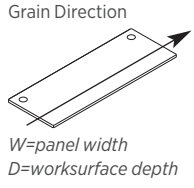

NOTES:

- Worksurfaces may be used with Accelerate®, Abound® and Voi® products.
- Worksurfaces are constructed of laminate on 1/8" solid core high-performance particleboard.
- Models up to 42"W are standard with one centered grommet. Models 48"W and wider are standard with two grommets.
- Accelerate® adds a "C" prefix and "T" suffix and Abound® adds a "B" prefix and "T" suffix to the Model Number for primary worksurfaces to span a TEE or EXTENDED STRAIGHT connection. Add upcharge of \$30 List per model.
- Add suffix "N" to Model Number for worksurfaces with no grommets. No upcharge.
- Woodgrain runs horizontally across surface.

- ! 18"D models are not available in Tee-Span but can be accommodated through Tailored Solutions.
- ! EXTENDED STRAIGHT worksurfaces are available with grommets only.
- ! 60"W, 66"W and 72"W worksurfaces require one or more of the following: worksurface support brackets, end panel, external channel universal support leg or pedestal support in conjunction with cantilever brackets.
- ! When a run of worksurfaces equals or exceeds 6 feet, a floor support is required for worksurface structural assurance.
- ! All worksurfaces load tested to BIFMA standards.

HOW TO SPECIFY

<p>Select Model Number</p> <p>For Tee-Span or Extended straight connection: Accelerate® adds a "C" prefix and "T" suffix (\$30 upcharge per model)</p> <p>Abound® adds a "B" prefix and "T" suffix (\$30 upcharge per model)</p> <p>No Grommet option: Add "N" suffix (no upcharge)</p> <p>HWR2424P .</p> <p>HCWR2424PT .</p> <p>HBWR2424PT .</p> <p>HWR2424PN .</p>	<p>Select Laminate</p> <p>See page 455</p> <p>A5 .</p> <p>A5 .</p> <p>A5 .</p> <p>A5 .</p>	<p>Select Edge Color</p> <p>See page 455</p> <p>K .</p> <p>K .</p> <p>K .</p> <p>K .</p>	<p>Select Grommet Color</p> <p>See page 455</p> <p>T1</p> <p>T1</p> <p>T1</p>
---	---	---	--

SYSTEMS WORKSURFACES

Primary

GSA SIN 33721



Icon Legend on page 19

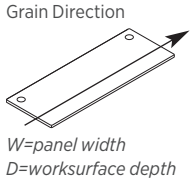

DESCRIPTION	MODEL	SHIP WEIGHT	CUBE	L1 LIST PRICE	L2 LIST PRICE
Primary and/or Return Worksurfaces					
24"W x 30"D	HWR3024P	47	2.2	\$320	\$332
30"W x 30"D	HWR3030P	56	2.6	\$368	\$380
36"W x 30"D	HWR3036P	62	3.1	\$389	\$404
42"W x 30"D	HWR3042P	64	3.6	\$414	\$429
48"W x 30"D	HWR3048P	68	4.0	\$436	\$451
54"W x 30"D	HWR3054P	80	5.0	\$469	\$489
60"W x 30"D	HWR3060P	101	5.0	\$520	\$540
66"W x 30"D	HWR3066P	105	6.0	\$555	\$575
72"W x 30"D	HWR3072P	105	6.0	\$593	\$613
84"W x 30"D	HWR3084P	127	6.2	\$800	\$825

NOTES:

- Worksurfaces may be used with Accelerate®, Abound® and Voi® products.
- Worksurfaces are constructed of laminate on 1½" solid core high-performance particleboard.
- Models up to 42"W are standard with one centered grommet. Models 48"W and wider are standard with two grommets.
- Accelerate® adds a "C" prefix and "T" suffix and Abound® adds a "B" prefix and "T" suffix to the Model Number for primary worksurfaces to span a TEE or EXTENDED STRAIGHT connection (adds 2¼" to width). Add upcharge of \$30 List per model.
- Add suffix "N" to Model Number for worksurfaces with no grommets. No upcharge.
- Woodgrain runs horizontally across surface.

- ! EXTENDED STRAIGHT worksurfaces are available with grommets only.
- ! 60"W, 66"W, 72"W, and 84"W worksurfaces require one or more of the following: worksurface support brackets, end panel, external channel universal support leg or pedestal support in conjunction with cantilever brackets.
- ! When a run of worksurfaces equals or exceeds 6 feet, a floor support is required for worksurface structural assurance.
- ! All worksurfaces load tested to BIFMA standards.

EXTERNAL CHANNEL SELECTION GUIDE						
Support Combination		Rectangle Worksurface Width				
Worksurface End Support 1	Worksurface End Support 2	54	60	66	72	84
End Panel	End Panel	42"	48"	54"	60"	72"
End Panel	Pedestal	NA	NA	NA	42"	48"
End Panel	Worksurface Brackets	42"	48"	54"	60"	72"
End Panel	Cantilever	42"	48"	54"	60"	72"
End Panel	Open Leg	42"	48"	54"	60"	72"
Pedestal	Pedestal	NA	NA	NA	NA	NA
Pedestal	Worksurface Brackets	NA	NA	NA	42"	48"
Pedestal	Cantilever	NA	NA	NA	42"	48"
Pedestal	Open Leg	NA	NA	NA	42"	48"
Worksurface Brackets	Worksurface Brackets	42"	48"	54"	60"	72"
Worksurface Brackets	Cantilever	42"	48"	54"	60"	72"
Worksurface Brackets	Open Leg	42"	48"	54"	60"	72"

See page 189 for External Channel models.

HOW TO SPECIFY

<p>Select Model Number</p> <p>For Tee-Span or Extended straight connection: Accelerate® adds a "C" prefix and "T" suffix (\$30 upcharge per model)</p> <p>Abound® adds a "B" prefix and "T" suffix (\$30 upcharge per model)</p> <p>No Grommet option: Add "N" suffix (no upcharge)</p> <p>HWR3024P .</p> <p>HCWR3024PT .</p> <p>HBWR3024PT .</p> <p>HWR3024PN .</p>	<p>Select Laminate</p> <p>See page 455</p> <p>A 5 .</p> <p>A 5 .</p> <p>A 5 .</p> <p>A 5 .</p>	<p>Select Edge Color</p> <p>See page 455</p> <p>K .</p> <p>K .</p> <p>K .</p> <p>K .</p>	<p>Select Grommet Color</p> <p>See page 455</p> <p>T 1</p> <p>T 1</p> <p>T 1</p>
---	---	---	---



SYSTEMS WORKSURFACES

Wedge

	DESCRIPTION	MODEL	SHIP WEIGHT	CUBE	L1 LIST PRICE	L2 LIST PRICE
<p>Grain Direction</p>	Wedge Worksurfaces					
	48" A x 24" B x 30" C	HWD244830P	64	4.8	\$555	\$570
	54" A x 24" B x 30" C	HWD245430P	80	4.8	\$596	\$616
	60" A x 24" B x 30" C	HWD246030P	101	4.8	\$638	\$658
	66" A x 24" B x 30" C	HWD246630P	105	5.7	\$679	\$699
	72" A x 24" B x 30" C	HWD247230P	109	5.7	\$724	\$744
	Wedge Worksurfaces					
	48" A x 30" B x 24" C	HWD304824P	64	4.8	\$555	\$570
	54" A x 30" B x 24" C	HWD305424P	80	4.8	\$596	\$616
	60" A x 30" B x 24" C	HWD306024P	101	4.8	\$638	\$658
	66" A x 30" B x 24" C	HWD306624P	105	5.7	\$679	\$699
	72" A x 30" B x 24" C	HWD307224P	109	5.7	\$724	\$744

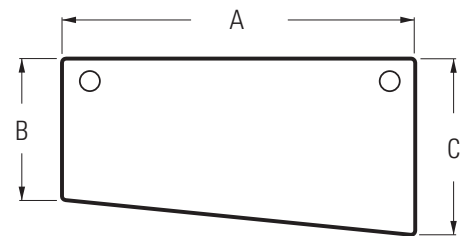
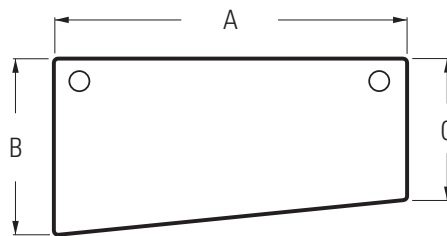

See matrix on page 582.

NOTES:

- Worksurfaces may be used with Accelerate®, Abound® and Voi® products.
 - Worksurfaces are constructed of laminate on 1½" solid core particleboard.
 - Refer to Worksurface Supports, pages 604-608.
 - Universal support leg can be used to share support when worksurfaces are placed side-by-side.
 - Add suffix "N" to Model Number for worksurfaces with no grommets. No upcharge.
 - Woodgrain runs horizontally across surface.
- ❗ 60"W, 66"W and 72"W worksurfaces require one or more of the following: worksurface support brackets, end panel, external channel universal support leg or pedestal support in conjunction with cantilever brackets. A full end panel can also be used for support in place of cantilever brackets.
- ❗ When a run of worksurfaces equals or exceeds 6 feet, a floor support is required for worksurface structural assurance.

HOW TO SPECIFY

<p>Select Model Number</p> <p>No Grommet option: Add "N" suffix (no upcharge)</p> <p>HWD244830P .</p> <p>HWD244830PN .</p>	<p>Select Laminate</p> <p>See page 455</p> <p>A5 .</p> <p>A5 .</p>	<p>Select Edge Color</p> <p>See page 455</p> <p>K .</p> <p>K .</p>	<p>Select Grommet Color</p> <p>See page 455</p> <p>T1</p>
---	---	---	--

SYSTEMS WORKSURFACES

Corner

GSA SIN 33721



Icon Legend on page 19

WORKSTATIONS

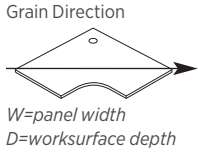

DESCRIPTION

Corner Worksurfaces with Curved User Edge

- 36"W x 24"D
- 42"W x 24"D
- 48"W x 24"D
- 42"W x 30"D
- 48"W x 30"D

MODEL

- HWC3624P**
- HWC4224P**
- HWC4824P**
- HWC4230P**
- HWC4830P**

SHIP WEIGHT

- 53
- 65
- 76
- 72
- 77

CUBE

- 3.7
- 4.9
- 6.3
- 6.3
- 6.3

L1 LIST PRICE

- \$542**
- \$573**
- \$644**
- \$673**
- \$726**

L2 LIST PRICE

- \$557**
- \$588**
- \$659**
- \$688**
- \$741**

- HWC3624P will not accept the H4022, H4028, or H4029 keyboard platforms.
- One small worksurface bracket standard with each worksurface.

! Corner worksurfaces must match exactly the panel behind them, i.e.: a 36" panel must be used on the back two sides of model HWC3624P.

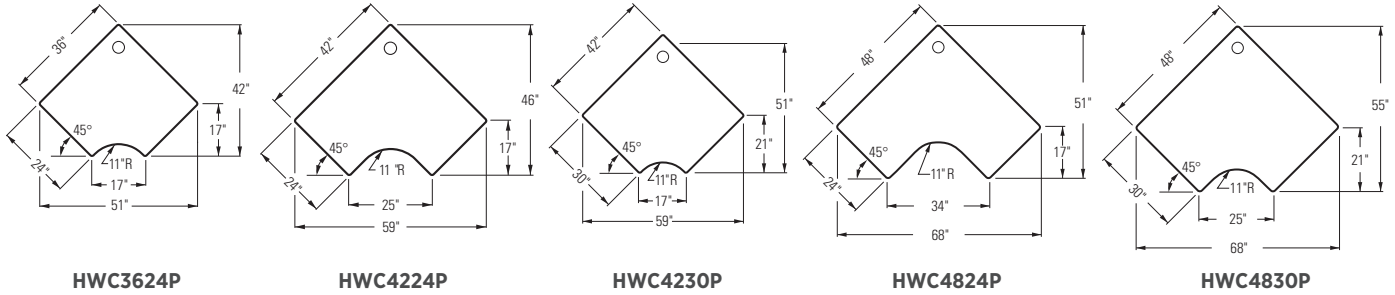

NOTES:

- Worksurfaces may be used with Accelerate®, Abound® and Voi® products.
- Add suffix **"N"** to Model Number for worksurfaces with no grommets. No upcharge.
- Worksurfaces are constructed of laminate on 1½" solid core high-performance particleboard.
- Refer to Worksurface Supports, pages 604-608.

HOW TO SPECIFY

<p>Select Model Number</p> <p>No Grommet option: Add "N" suffix (no upcharge)</p> <p>HWC3624P .</p> <p>HWC3624PN .</p>	<p>Select Laminate</p> <p>See page 455</p> <p>AS .</p> <p>AS .</p>	<p>Select Edge Color</p> <p>See page 455</p> <p>K .</p> <p>K .</p>	<p>Select Grommet Color</p> <p>See page 455</p> <p>T1</p>
--	---	---	--



SYSTEMS WORKSURFACES

Corner

Grain Direction

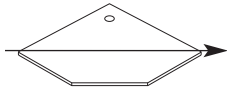

W=panel width
D=worksurface depth

DESCRIPTION

Corner Worksurfaces with Straight User Edge

- 36"W x 24"D
- 42"W x 24"D
- 48"W x 24"D
- 42"W x 30"D
- 48"W x 30"D

MODEL

- HWCS3624P** Ⓢ
- HWCS4224P**
- HWCS4824P**
- HWCS4230P**
- HWCS4830P**

SHIP WEIGHT

- 53
- 65
- 76
- 72
- 77

CUBE

- 3.7
- 4.9
- 6.3
- 6.3
- 6.3

L1 LIST PRICE

- \$522
- \$546
- \$603
- \$657
- \$668

L2 LIST PRICE

- \$537
- \$561
- \$618
- \$672
- \$683

- HWCS3624P will not accept the H4022, H4028, or H4029 keyboard platforms.
- One small worksurface bracket standard with each worksurface.

ⓘ Corner worksurfaces must match exactly the panel behind them, i.e.: a 36" panel must be used on the back two sides of model HWCS3624P.

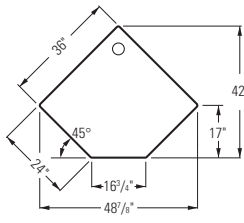

HWCS3624P

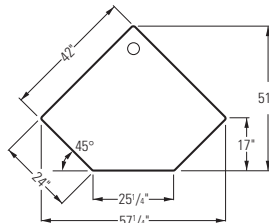

HWCS4224P

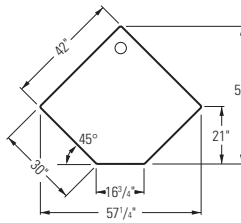

HWCS4230P

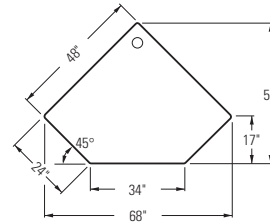

HWCS4824P

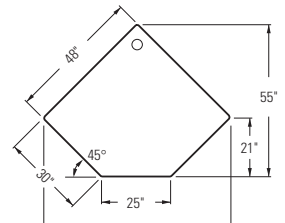

HWCS4830P

NOTES:

- Worksurfaces may be used with Accelerate®, Abound® and Voi® products.
- Add suffix **"N"** to Model Number for worksurfaces with no grommets. No upcharge.
- Worksurfaces are constructed of laminate on 1 1/8" solid core high-performance particleboard.
- Refer to Worksurface Supports, pages 604-608.

HOW TO SPECIFY

Select Model Number
No Grommet option: Add **"N"** suffix (no upcharge)

HWCS3624P .
HWCS3624PN .

Select Laminate
See page 455

AS .
AS .

Select Edge Color
See page 455

K .
K .

Select Grommet Color
See page 455

T1

SYSTEMS WORKSURFACES

120 Degree Corner

GSA SIN 33721



Icon Legend on page 19

WORKSTATIONS

Grain Direction

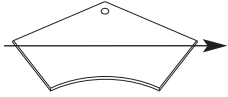

W=panel width

D=worksurface depth

DESCRIPTION

Abound® and Accelerate® 120 Degree Corner Worksurfaces with Curved User Edge

36"W x 24"D

42"W x 24"D

48"W x 24"D

42"W x 30"D

48"W x 30"D

- HBWCT3624P will not accept the H4022, HE4022, H4028, or H4029 keyboard platforms.
- One small work surface bracket standard with each work surface.

- ❗ Corner work surfaces must match exactly the panel behind them, i.e.: a 36" panel must be used on the back two sides of model HBWCT3624P.

MODEL

HBWCT3624P

HBWCT4224P

HBWCT4824P

HBWCT4230P

HBWCT4830P

SHIP WEIGHT

75

96

107

102

112

CUBE

7.7

9.2

9.2

11.4

11.4

L1 LIST PRICE

\$777

\$833

\$965

\$1094

\$1164

L2 LIST PRICE

\$792

\$848

\$980

\$1109

\$1179

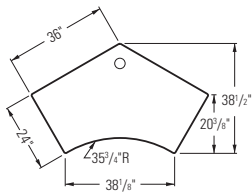

HBWCT3624P

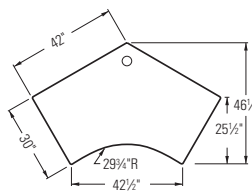

HBWCT4230P

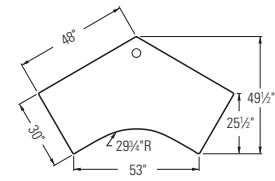

HBWCT4830P

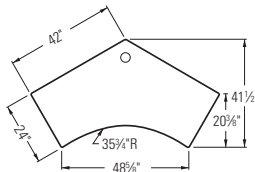

HBWCT4224P

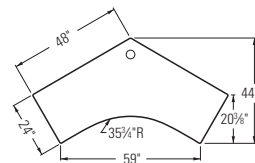

HBWCT4824P

NOTES:

- Worksurfaces are constructed of laminate on 1 1/8" solid core high-performance particleboard.
- Add suffix "N" to Model Number for worksurfaces with no grommets. No upcharge.
- Refer to Worksurface Supports, pages 604-608.
- If used at an end of run, full end panel needs to be ordered — see page 604.

HOW TO SPECIFY

Select Model Number

No Grommet option: Add "N" suffix (no upcharge)

HBWCT3624P .

HBWCT3624PN .

Select Laminate

See page 455

A5 .

A5 .

Select Edge Color

See page 455

K .

K

Select Grommet Color

See page 455

T1



SYSTEMS WORKSURFACES

Corner Cove

Grain Direction

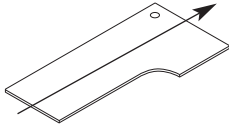

DESCRIPTION

Corner Cove Worksurfaces, Left Hand

60" A x 36" B x 24" C x 24" D
60" A x 36" B x 30" C x 24" D

60" A x 48" B x 24" C x 24" D
60" A x 48" B x 24" C x 30" D
60" A x 48" B x 30" C x 24" D
60" A x 48" B x 30" C x 30" D

72" A x 36" B x 24" C x 24" D
72" A x 36" B x 30" C x 24" D

72" A x 48" B x 24" C x 24" D
72" A x 48" B x 24" C x 30" D
72" A x 48" B x 30" C x 24" D
72" A x 48" B x 30" C x 30" D

MODEL SHIP WEIGHT CUBE L1 LIST PRICE L2 LIST PRICE

HWV73AALP	67	5.9	\$610	\$635
HWV73BALP	76	5.9	\$631	\$656
HWV75AALP	85	7.7	\$668	\$698
HWV75ABLP	94	7.7	\$691	\$721
HWV75BALP	92	7.7	\$691	\$721
HWV75BBLP	99	7.7	\$717	\$747
HWV93AALP	75	7.0	\$668	\$698
HWV93BALP	83	7.0	\$691	\$721
HWV95AALP	96	9.2	\$834	\$869
HWV95ABLP	107	9.2	\$857	\$892
HWV95BALP	102	9.2	\$857	\$892
HWV95BBLP	112	9.2	\$884	\$919

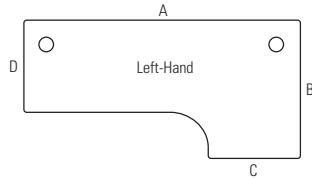

NOTES:

- Worksurfaces may be used with Accelerate®, Abound® and Voi® products.
- Worksurfaces are constructed of laminate on 1/8" solid core high-performance particleboard.
- Includes a rear-support bracket in Charcoal only.
- Add suffix **"N"** to Model Number for worksurfaces with no grommets. No upcharge.
- Refer to Worksurface Supports, pages 604-608.
- ! Panel-hung application requires two panels of corresponding width joined at 90°.
- ! When a run of worksurfaces equals or exceeds 6 feet, a floor support is required for worksurface structural assurance.
- ! 60"W, 66"W and 72"W worksurfaces require one or more of the following: worksurface support brackets, end panel, external channel universal support leg or pedestal support in conjunction with cantilever brackets.

HOW TO SPECIFY

<p>Select Model Number</p> <p>No Grommet option: Add "N" suffix (no upcharge)</p> <p>HWV73AALP .</p> <p>HWV73AALPN .</p>	<p>Select Laminate</p> <p>See page 455</p> <p>AS .</p> <p>AS .</p>	<p>Select Edge Color</p> <p>See page 455</p> <p>K .</p> <p>K .</p>	<p>Select Grommet Color</p> <p>See page 455</p> <p>T1</p>
--	---	---	--

SYSTEMS WORKSURFACES

Corner Cove

GSA SIN 33721



Icon Legend on page 19

WORKSTATIONS

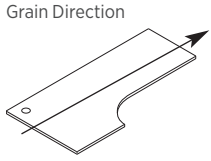

DESCRIPTION

Corner Cove Worksurfaces, Right Hand

60" A x 36" B x 24" C x 24" D
60" A x 36" B x 30" C x 24" D

60" A x 48" B x 24" C x 24" D
60" A x 48" B x 24" C x 30" D
60" A x 48" B x 30" C x 24" D
60" A x 48" B x 30" C x 30" D

72" A x 36" B x 24" C x 24" D
72" A x 36" B x 30" C x 24" D

72" A x 48" B x 24" C x 24" D
72" A x 48" B x 24" C x 30" D
72" A x 48" B x 30" C x 24" D
72" A x 48" B x 30" C x 30" D

MODEL

HWV73AARP
HWV73BARP

HWV75AARP
HWV75ABRP
HWV75BARP
HWV75BBRP

HWV93AARP
HWV93BARP

HWV95AARP
HWV95ABRP
HWV95BARP
HWV95BBRP

SHIP WEIGHT

67
76

85
94
92
99

75
83

96
107
102
112

CUBE

5.9
5.9

7.7
7.7
7.7
7.7

7.0
7.0

9.2
9.2
9.2
9.2

L1 LIST PRICE

\$610
\$631

\$668
\$691
\$691
\$717

\$668
\$691

\$834
\$857
\$857
\$884

L2 LIST PRICE

\$635
\$656

\$698
\$721
\$721
\$747

\$698
\$721

\$869
\$892
\$892
\$919

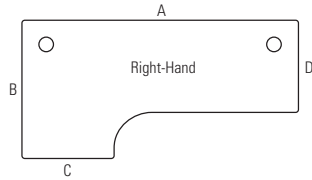

NOTES:

- Worksurfaces may be used with Accelerate®, Abound® and Voi® products.
- Worksurfaces are constructed of laminate on 1/8" solid core high-performance particleboard.
- Includes a rear-support bracket in Charcoal only.
- Add suffix **"N"** to Model Number for worksurfaces with no grommets. No upcharge.
- Refer to Worksurface Supports, pages 604-608.

- ! Panel-hung application requires two panels of corresponding width joined at 90°.
- ! When a run of worksurfaces equals or exceeds 6 feet, a floor support is required for worksurface structural assurance.
- ! 60"W, 66"W and 72"W worksurfaces require one or more of the following: worksurface support brackets, end panel, external channel universal support leg or pedestal support in conjunction with cantilever brackets.

HOW TO SPECIFY

<p>Select Model Number</p> <p>No Grommet option: Add "N" suffix (no upcharge)</p> <p>HWV73AARP . HWV73AARP N .</p>	<p>Select Laminate</p> <p>See page 455</p> <p>AS . AS .</p>	<p>Select Edge Color</p> <p>See page 455</p> <p>K . K .</p>	<p>Select Grommet Color</p> <p>See page 455</p> <p>T1</p>
--	--	--	--



SYSTEMS WORKSURFACES

Jetty / Peninsula

	DESCRIPTION	MODEL	SHIP WEIGHT	CUBE	L1 LIST PRICE	L2 LIST PRICE
<p>Grain Direction</p>	Jetty Worksurfaces, Left Hand					
	48" A x 66" B x 24" C x 30" D	HWJ58ABLP	84	9.2	\$838	\$868
	48" A x 66" B x 30" C x 30" D	HWJ58BBLP	91	9.2	\$839	\$869
	48" A x 72" B x 24" C x 30" D	HWJ59ABLP	88	9.2	\$843	\$873
	48" A x 72" B x 30" C x 30" D	HWJ59BBLP	94	9.2	\$840	\$870
	! Requires support column — see page 606. Order support column separately.					
<p>Grain Direction</p>	Jetty Worksurfaces, Right Hand					
	48" A x 66" B x 24" C x 30" D	HWJ58ABRP	84	9.2	\$838	\$868
	48" A x 66" B x 30" C x 30" D	HWJ58BBRP	91	9.2	\$839	\$869
	48" A x 72" B x 24" C x 30" D	HWJ59ABRP	88	9.2	\$843	\$873
	48" A x 72" B x 30" C x 30" D	HWJ59BBRP	94	9.2	\$840	\$870
	! Requires support column — see page 606. Order support column separately.					
<p>Grain Direction</p>	Peninsula Worksurfaces					
	60" W x 24" D	HWP2460P	65	4.9	\$393	\$413
	66" W x 24" D	HWP2466P	72	4.6	\$479	\$499
	72" W x 24" D	HWP2472P	95	5.5	\$539	\$559
	60" W x 30" D	HWP3060P	68	5.0	\$629	\$649
	66" W x 30" D	HWP3066P	75	6.0	\$690	\$710
	72" W x 30" D	HWP3072P	98	6.0	\$760	\$780
	! Peninsula worksurface width must correspond to the width of its support panel. Requires support column — see page 606. Order support column separately.					

NOTES:

- Worksurfaces may be used with Accelerate®, Abound® and Voi® products.
- Worksurfaces are constructed of laminate on 1½" solid core high-performance particleboard.
- Order support column separately — see page 606.
- Can also be attached perpendicular to a primary worksurface using Flat Brackets. Do not attach to a worksurface supported with Cantilever Brackets.
- Add suffix "N" to Model Number for worksurfaces with no grommets. No upcharge.
- Refer to Worksurface Supports, pages 604-608.
- ! Not designed to be used freestanding.

HOW TO SPECIFY

<p>Select Model Number</p> <p>No Grommet option: Add "N" suffix (no upcharge)</p> <p>HWJ58ABLP .</p> <p>HWJ58ABLPN .</p>	<p>Select Laminate</p> <p>See page 455</p> <p>AS .</p> <p>AS .</p>	<p>Select Edge Color</p> <p>See page 455</p> <p>K .</p> <p>K .</p>	<p>Select Grommet Color</p> <p>See page 455</p> <p>T1</p>
---	---	---	--

SYSTEMS WORKSURFACES

Half-Round / Quarter Round / 60° Wedge

GSA SIN 33721



Icon Legend on page 19

WORKSTATIONS

Grain Direction

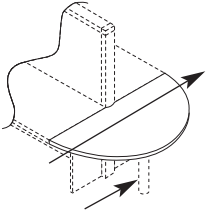

Requires Support Column — see page 606.

DESCRIPTION

Abound® Half-Round Worksurfaces

50"W x 30"D Connects to two 24"D Worksurfaces
62"W x 36"D Connects to two 30"D Worksurfaces

MODEL

HBWD2450P
HBWD3062P

SHIP WEIGHT

52
58

CUBE

5.0
6.1

L1 LIST PRICE

\$621
\$724

L2 LIST PRICE

\$636
\$744

Accelerate® Half-Round Worksurfaces

50"W x 30"D Connects to two 24"D Worksurfaces
62"W x 36"D Connects to two 30"D Worksurfaces

HCWD2450P
HCWD3062P

52
58

5.0
6.1

\$621
\$724

\$636
\$744

NOTES: Order one Support Column and two Universal Support Legs or Full End Panel — see pages 604-606.

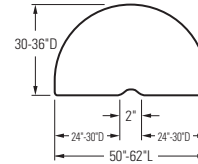

Grain Direction

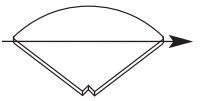

Abound® Quarter-Round Worksurfaces

24"W x 24"W Connects to two 24"D Worksurfaces
30"W x 30"W Connects to two 30"D Worksurfaces

HBWQ2424P
HBWQ3030P

18
25

2.6
3.7

\$356
\$447

\$371
\$467

Accelerate® Quarter-Round Worksurfaces

24"W x 24"W Connects to two 24"D Worksurfaces
30"W x 30"W Connects to two 30"D Worksurfaces

HCWQ2424P
HCWQ3030P

18
25

2.6
3.7

\$356
\$447

\$371
\$467

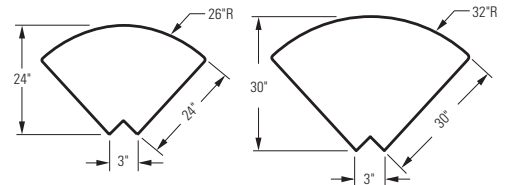

HBWQ2424P
HCWQ2424P

HBWQ3030P
HCWQ3030P

Grain Direction

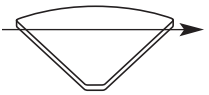

Abound® 60° Wedge Worksurfaces for use with 120 degree Universal Connector

24"W x 24"W Abound® Only
30"W x 30"W Abound® Only

HBWQT2424P
HBWQT3030P

18
25

2.6
3.7

\$395
\$459

\$410
\$479

Accelerate® 60° Wedge Worksurfaces for use with 120 degree Universal Connector

24"W x 24"W Accelerate® Only
30"W x 30"W Accelerate® Only

HCWQT2424P
HCWQT3030P

17
25

2.4
2.9

\$393
\$456

\$408
\$476

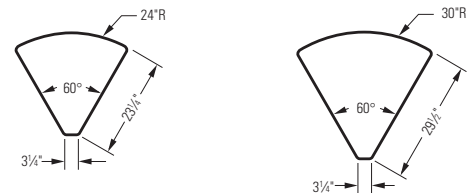

HBWQT2424P
HCWQT2424P

HBWQT3030P
HCWQT3030P

NOTES:

- Worksurfaces are constructed of laminate on 1/8" solid core high-performance particleboard.

Half-Round Worksurfaces

- Order Support Column and End Panels separately.

Quarter Round Worksurfaces

- Two Flat Brackets and one Tie Bracket included.

60° Wedge Worksurfaces

- Two flat brackets and one tie bracket included.
- Refer to Worksurface Supports, pages 604-608.

HOW TO SPECIFY

Select Model Number

HBWD2450P
HCWD2450P

Select Laminate

See page 455

A5
A5

Select Edge Color





See page 455

K
K

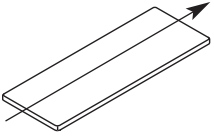

SYSTEMS COUNTERTOPS

Straight and Corner

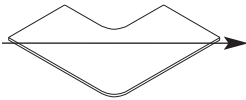
	DESCRIPTION	MODEL	SHIP WEIGHT	CUBE	L1 LIST PRICE	L2 LIST PRICE
Grain Direction 	Abound® and Accelerate® 15"D Straight Countertops					
	24"W x 15"D	HBCSR1524P	19	1.4	\$222	\$232
	30"W x 15"D	HBCSR1530P	25	1.4	\$245	\$255
	36"W x 15"D	HBCSR1536P 	27	1.6	\$274	\$284
	42"W x 15"D	HBCSR1542P	32	1.8	\$282	\$292
	48"W x 15"D	HBCSR1548P 	38	2.1	\$298	\$308
	60"W x 15"D	HBCSR1560P 	48	2.6	\$378	\$393
	66"W x 15"D	HBCSR1566P	53	2.7	\$391	\$406
	72"W x 15"D	HBCSR1572P 	59	3.1	\$406	\$421
Grain Direction 	Abound® and Accelerate® 15"D Corner Countertops					
	24"W x 24"D	HBCSR2424P	44	1.4	\$424	\$439
	30"W x 30"D	HBCSR3030P	51	1.4	\$493	\$508
	36"W x 36"D	HBCSR3636P	58	1.6	\$549	\$569

NOTES:

- Countertops constructed with high-pressure laminate.
- Specify laminate and Edgeband options color.

HOW TO SPECIFY

Select Model Number H B C S R 1 5 2 4 P .	Select Laminate See page 455 A 5 .	Select Edge Color See page 455 K
---	---	---

SYSTEMS COUNTERTOPS

Straight and Corner

GSA SIN 33721



Icon Legend on page 19

WORKSTATIONS

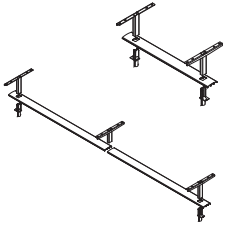

DESCRIPTION

Abound® Raised Straight Countertop Kits

24"W
30"W
36"W
42"W
48"W
60"W
66"W
72"W

MODEL

HRVBR1524
HRVBR1530
HRVBR1536
HRVBR1542
HRVBR1548
HRVBR1560
HRVBR1566
HRVBR1572

SHIP WEIGHT

5
5
6
6
7
8
8
9

CUBE

1.0
1.0
2.0
2.0
2.0
2.0
3.0
3.0

LIST PRICE BY PAINT GRADE

P1 P2

\$133	\$150
\$140	\$157
\$148	\$165
\$153	\$170
\$159	\$176
\$189	\$206
\$202	\$219
\$217	\$234

! Do not order top caps for the panels the Countertop Kits will be installed on. Countertop Kits come with the necessary top caps and hardware.

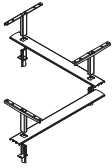

Abound® Raised Corner Countertop Kits

24"W
30"W
36"W

HRVBR1524P
HRVBR1530P
HRVBR1536P

5
6
6

1.0
1.0
2.0

\$166	\$183
\$175	\$192
\$183	\$200

! Do not order top caps for the panels the Countertop Kits will be installed on. Countertop Kits come with the necessary top caps and hardware.

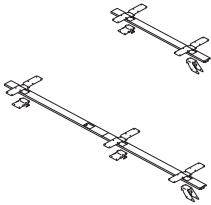

Abound® Straight Countertop Kits

24"W
30"W
36"W
42"W
48"W
60"W
66"W
72"W

HBCKIT24
HBCKIT30
HBCKIT36
HBCKIT42
HBCKIT48
HBCKIT60
HBCKIT66
HBCKIT72

5
5
6
6
7
8
8
9

0.7
0.9
0.9
1.2
1.4
1.8
1.8
1.9

\$51	N/A
\$53	N/A
\$55	N/A
\$57	N/A
\$59	N/A
\$62	N/A
\$64	N/A
\$66	N/A

- ! Straight Countertop Kits must match the width of the corresponding panel onto which they are installed.
- ! 66"W kit must be used with 30" and 36"W frames.
- ! 72"W kit must be used with two 36"W frames.
- ! Do not order top caps for the panels onto which the Countertop Kits are installed. Countertop Kits come with the necessary top caps and hardware.

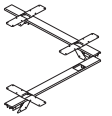

Abound® Corner Countertop Kits

24"W
30"W
36"W

HBCKKIT24
HBCKKIT30
HBCKKIT36

5
6
6

0.7
1.0
1.0

\$61	N/A
\$68	N/A
\$70	N/A

! Do not order top caps for the panels the Countertop Kits will be installed on. Countertop Kits come with the necessary top caps and hardware.

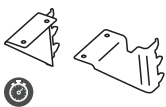

Accelerate® Countertop Bracket Kit

HECB01

1

0.1

\$53 \$56

- ! For use with all panel heights, except 42½".
- ! Top caps required and specified separately from Accelerate® Countertop Bracket Kits.

Accelerate® Countertop Bracket Kit for 42½"H Panels

HECB42

1

0.1

\$53 \$56

- ! For use with 42½"H Panels only.
- ! Top caps required and specified separately from Accelerate® Countertop Bracket Kits.

! Bracket kits include one right and one left hand bracket. Order two sets of brackets for the straight countertop models and three sets for the corner countertop models. To be used on Accelerate® panels only.

SPECIFYING EXAMPLE: HECB01.LOFT

HOW TO SPECIFY

Select Model Number

Select Paint Color

See page 455

HRVBR1524

A5



Icon Legend on page 19

SYSTEMS SHELVES

Corner Shelves

DESCRIPTION	MODEL	SHIP WEIGHT	CUBE	L1	L2
				LIST PRICE	LIST PRICE
Corner Shelves 36" x 36" x 12"D 42" x 42" x 12"D	HCS3636P	33	3.6	\$403	\$423
	HCS4242P	33	3.6	\$422	\$447

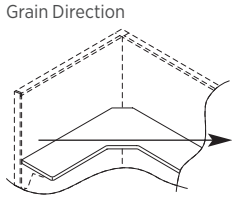

NOTES:

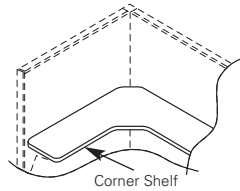

- Corner Shelves may be used with both Abound® and Accelerate® systems products.
- Diagonal leading edge = 10½"
- Diagonal depth = 22½"
- Includes panel attachment brackets.

HOW TO SPECIFY

Select Model Number HCS3636P	Select Laminate See page 455 A5	Select Edge Color See page 455 K	Select Paint Color See page 455 T1
--	--	---	---

DESCRIPTION	MODEL	SHIP WEIGHT	CUBE	LIST PRICE BY PAINT GRADE
				P1
Power Hub, 3" Grommet Mount, 6' Cord • Fits in 3" round grommet holes on the following product lines: 10500, 10700, Coordinate and Voi desks; Systems Worksurfaces; Huddle and Motivate tables and SmartLink. • Two grounded AC power outlets. • Includes 6' cord with three-prong plug. • Field installed with Plug-and-play ease.	HGRMTAC	1.3	0.2	\$116

NOTES: For additional information see the Workplace Tools section in the 2021 Shared Spaces Pricer.

ⓘ Available in black only (no color designation so use .X - Specify: HGRMTAC.X).

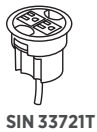

COORDINATE™ Height Adjustable Bases — Two-Leg

OPEN MARKET



Icon Legend on page 19

WORKSTATIONS

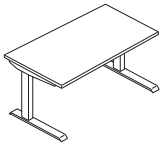
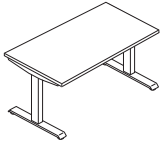

DESCRIPTION

Coordinate™ Height Adjustable Base – 2 Stage

2-Leg Rectangle T Foot
2-Leg Rectangle C Foot

MODEL

HREC2S2LTF
HREC2S2LCF

SHIP WEIGHT

66
66

CUBE

2.4
2.4

LIST PRICE

\$950
\$950

NOTES:

- Base is a dual motor 2-stage design. Legs raise from 25⁵/₈" to 45¹/₄".
- Base telescopes to accommodate any rectangular worksurface between 24"D x 42"W and 30"D x 72"W.
- Supports weight capacity of 250 lbs. (excluding worksurface weight). Concinnity®, Systems, Voi®, 10500, and Preside® all have worksurfaces within this range.
- Control Box: 120V, 4A, 60Hz, 400W.
- 9' grounded power cord.
- 1¹/₈" / second travel speed.
- <50 dB noise rating.
- **HON 7-Year Limited Warranty.**

Coordinate™ Height Adjustable Base – Max 3 Stage

2-Leg Rectangle T Foot

HMREC3S2LTF

66

2.4

\$1173

NOTES:

- Base is a dual motor 2-stage design. Legs raise from 21⁵/₈" to 47³/₄".
- Base telescopes to accommodate any rectangular worksurface between 24"D x 42"W and 30"D x 96"W.
- Supports weight capacity of 350 lbs. (excluding worksurface weight). Concinnity®, Systems, Voi®, 10500, and Preside® all have worksurfaces within this range.
- Control Box: 120V, 4A, 60Hz, 400W.
- 9' grounded power cord.
- 1¹/₈" / second travel speed.
- <50 dB noise rating.
- **HON 7-Year Limited Warranty.**

Coordinate™ Height Adjustable Base – 3 Stage

2-Leg Rectangle T Foot
2-Leg Rectangle C Foot

HREC3S2LTF
HREC3S2LCF

66
66

2.4
2.4

\$1047
\$1047

NOTES:

- Base is a dual motor 3-stage design. Legs raise from 21⁵/₈" to 47³/₄".
- Base telescopes to accommodate any rectangular worksurface between 24"D x 42"W and 30"D x 72"W.
- Supports weight capacity of 250 lbs. (excluding worksurface weight). Concinnity®, Systems, Voi®, 10500, and Preside® all have worksurfaces within this range.
- Control Box: 120V, 4A, 60Hz, 400W.
- 9' grounded power cord.
- 1¹/₈" / second travel speed.
- <50 dB noise rating.
- **HON 7-Year Limited Warranty.**

Coordinate™ Easy to Assemble 2-Leg Height Adjustable Base – 2 Stage

24"D Feet

HHBETA2S2L

77

4.0

\$728

NOTES:

- **Legs raise from 26¹/₄" to 43¹/₂", excluding worksurface.**
- Base telescopes to accommodate rectangular worksurfaces between 24"D x 48"W and 30"D x 60"W.
- Supports weight capacity of 180 lbs.
- Control Box: 100-240V, 3.6A, 50/60Hz, 400W.
- 9' grounded power cord.
- 1¹/₂" / second travel speed.
- **HON 5-Year Limited Warranty.**

Available in SVR Silver finish only.

Available with Basic Up/Down control only.

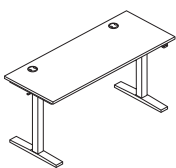

NOTES:

- Compatible with select rectangular Voi® and Systems Worksurfaces. See the Tables section in the 2021 Shared Spaces Pricer for more information.

HOW TO SPECIFY

Select Model Number	Select Paint Color	Select Foot	Select Keypad
P71 Black P8L Nickel PD8 White SVR Silver <i>Available on model HHBETA2S2L only</i>	X Standard Foot	UD Basic Up/Down MEM Memory Preset PDL Paddle RTG Rotating (\$50 upcharge) FPD Foot Pedal (\$175 upcharge)	
HREC2S2LTF	P71	X	MEM



Height Adjustable Bases — Three-Leg

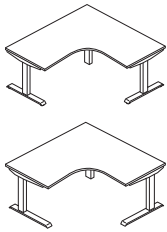

DESCRIPTION

Coordinate™ Height Adjustable Base – 3 Stage

- 3-Leg Rectangle T Foot
- 3-Leg Rectangle C Foot

NOTES:

- Base is a three motor 3-stage design. Legs raise from 21⁵/₈" to 47³/₄".
- Base telescopes to accommodate worksurfaces between 24"D x 42"W¹ x 60"W² and 30"D x 72"W¹ x 72"W².
- Supports weight capacity of 375 lbs. (excluding worksurface weight). Can be used with 48" 120 degree and worksurface models.
- Control Box: 120V, 4A, 60Hz, 400W.
- 9' grounded power cord.
- 1¹/₂"/second travel speed.
- <50 dB noise rating.
- **HON 7-Year Limited Warranty.**

MODEL

SHIP WEIGHT

CUBE

LIST PRICE

HREC3S3LTF	91	3.6	\$1729
HREC3S3LCF	91	3.6	\$1729

NOTES:

- Compatible with select Corner Cove Worksurfaces. See the Tables section in the 2021 Shared Spaces Pricer for more information.
- All bases are compatible with electrical accessories in the Tables section in the 2021 Shared Spaces Pricer.
- ❗ When using two worksurfaces, a flat bracket is required. Bracket purchased separately — HHN831124, HHN831130 — see page 606.
- ❗ Telescoping horizontal frame will extend just over 2" from underside of the worksurface.

HOW TO SPECIFY

<p>Select Model Number</p> <p>H R E C 3 S 3 L T F .</p>	<p>Select Paint Color</p> <p>P71 Black P8L Nickel PD8 White</p> <p>P 7 1 .</p>	<p>Select Foot</p> <p>X Standard Foot</p> <p>X .</p>	<p>Select Keypad</p> <p>UD Basic Up/Down MEM Memory Preset PDL Paddle RTG Rotating (\$50 upcharge) FPD Foot Pedal (\$175 upcharge)</p> <p>M E M</p>
--	---	---	--

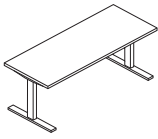

Base shown with work surface attached.



DESCRIPTION

MODEL

SHIP WEIGHT

CUBE

LIST PRICE

Coordinate™ Height Adjustable Base – 2 Stage
24”D Feet and Worksurface Brackets

HHAB2S2L

63

2.4

\$1006

NOTES:

- Base is a dual motor 2-stage design. Legs raise from 25⁵/₈” to 45¹/₄”.
- Base telescopes to accommodate any rectangular work surface between 24”D x 42”W and 30”D x 72”W.
- Supports weight capacity of 250 lbs. (excluding work surface weight). See the Tables section in the 2021 Shared Spaces Pricer for Voi® Worksurfaces. See the Tables section in the 2021 Shared Spaces Pricer for Systems Worksurfaces. For Height Adjustable Base Accessories see the Tables section in the 2021 Shared Spaces Pricer. Concinnity®, Systems, Voi®, 10500, and Preside® all have work surfaces within this range.
- Comes standard with one-touch, four memory controller with digital display; no specification needed, available in black finish only.
- **HON 7-Year Limited Warranty.**

ⓘ When attaching a Keyboard Tray, remember to also specify a Keyboard Spacer Kit (HKBS).

ⓘ Telescoping horizontal frame will extend just over 2” from underside of the work surface.

ⓘ Removal of stretcher bars in Coordinate™ base is required when pairing with a 42”W work surface.

SPECIFYING EXAMPLE: HHAB2S2L.P8L

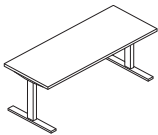

Base shown with work surface attached.



Coordinate™ Height Adjustable Base – 3 Stage
24”D Feet and Worksurface Brackets

HHAB3S2L

67

2.4

\$1120

NOTES:

- Base is a dual motor 3-stage design. Legs raise from 21⁵/₈” to 47³/₄”.
- Base telescopes to accommodate any rectangular work surface between 24”D x 42”W and 30”D x 72”W.
- Supports weight capacity of 250 lbs. (excluding work surface weight). Concinnity®, Systems, Voi®, 10500, and Preside® all have work surfaces within this range.
- Comes standard with one-touch, four memory controller with digital display; no specification needed, available in black finish only.
- **HON 7-Year Limited Warranty.**

ⓘ Telescoping horizontal frame will extend just over 2” from underside of the work surface.

ⓘ Removal of stretcher bars in Coordinate™ base is required when pairing with a 42”W work surface.

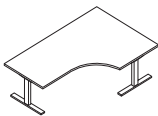

Base shown with work surface attached.



Coordinate™ 3-Leg Height Adjustable Base – 3 Stage
24”D Feet and Worksurface Brackets

HHAB3S3L

91

3.6

\$1896

NOTES:

- Base is a three motor 3-stage design. Legs raise from 21⁵/₈” to 47³/₄”.
- Base telescopes to accommodate work surfaces between 24”D x 42”W¹ x 60”W² and 30”D x 72”W¹ x 72”W².
- Supports weight capacity of 330 lbs. (excluding work surface weight). Can be used with 48” 120 degree and work surface models.
- Comes standard with one-touch, four memory controller with digital display; no specification needed, available in black finish only.
- **HON 7-Year Limited Warranty.**

ⓘ When using two work surfaces, a flat bracket is required. Bracket purchased separately — HHN831124, HHN831130 — see page 606.

ⓘ Telescoping horizontal frame will extend just over 2” from underside of the work surface.

NOTES:

- Compatible with select Rectangle and Corner Cove Worksurfaces. See the Tables section in the 2021 Shared Spaces Pricer for more information.
- Control Box: 120V, 4A, 60Hz, 400W.
- 9’ grounded power cord.
- 1¹/₂”/second travel speed.
- <50 dB noise rating.

ⓘ Coordinate™ Height Adjustable Bases not compatible with 36”D rectangular work surfaces.

HOW TO SPECIFY

<p>Select Model Number</p> <p>HHAB2S2L.P8L</p>	<p>Select Finish</p> <p>P71 Black P8L Nickel PD8 White</p> <p>P8L</p>
---	--

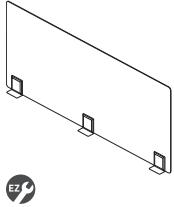

DESCRIPTION	MODEL	SHIP WEIGHT	CUBE	LIST PRICE BY PAINT GRADE		
				P1	P2	P3
Above Screens						
20"H x 45½"W, for 48"W Surfaces	HMTLSCRN2048	36.4	5.5	\$643	\$663	\$683
20"H x 51½"W, for 54"W Surfaces	HMTLSCRN2054	39.7	6.1	\$675	\$695	\$715
20"H x 57½"W, for 60"W Surfaces	HMTLSCRN2060	43.1	6.7	\$710	\$730	\$750
20"H x 63½"W, for 66"W Surfaces	HMTLSCRN2066	46.4	7.3	\$745	\$765	\$785
25"H x 45½"W, for 48"W Surfaces	HMTLSCRN2548	42.8	6.7	\$707	\$727	\$747
25"H x 51½"W, for 54"W Surfaces	HMTLSCRN2554	46.9	7.4	\$743	\$763	\$783
25"H x 57½"W, for 60"W Surfaces	HMTLSCRN2560	51.1	8.2	\$780	\$800	\$820
25"H x 63½"W, for 66"W Surfaces	HMTLSCRN2566	55.3	9.0	\$819	\$839	\$859

NOTES:

- Above screens are single-piece steel construction.
- Screens mount by using double stick tape, which provides the ability to mount to any surface.



DESCRIPTION	MODEL	SHIP WEIGHT	CUBE	LIST PRICE BY FABRIC GRADE		
				G1	G2	G3
Fabric Screens (Single) — 13"H						
36"W	HMPFSS3613	9.7	2.4	\$448	\$468	\$488
42"W	HMPFSS4213	11.0	1.7	\$461	\$481	\$501
48"W	HMPFSS4813 Ⓢ	12.3	2.9	\$571	\$591	\$611
54"W	HMPFSS5413 Ⓢ	13.6	2.4	\$600	\$620	\$640
60"W	HMPFSS6013 Ⓢ	14.8	3.6	\$658	\$678	\$698

NOTES: For use on single-sided stationary stations or height adjustable stations (one per worksurface).

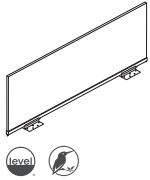

Fabric Screens (Single) — 20"H						
36"W	HMPFSS3620	11.2	3.2	\$572	\$592	\$612
42"W	HMPFSS4220	12.8	2.7	\$549	\$569	\$589
48"W	HMPFSS4820	14.3	4.0	\$651	\$671	\$691
54"W	HMPFSS5420	15.9	3.6	\$682	\$702	\$722
60"W	HMPFSS6020	17.3	4.9	\$722	\$742	\$762

NOTES: For use on single-sided stationary stations or height adjustable stations (one per worksurface).

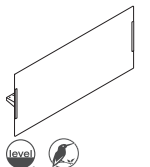

DESCRIPTION	MODEL	SHIP WEIGHT	CUBE	LIST PRICE
Above/Below Privacy Screen				
30"W x 28"H	HLSL2830	6	6.4	\$816
36"W x 28"H	HLSL2836	6	6.4	\$1129
42"W x 28"H	HLSL2842	6	6.3	\$1142
48"W x 28"H	HLSL2848	8	8.2	\$1217
54"W x 28"H	HLSL2854	9	8.6	\$1417
60"W x 28"H	HLSL2860	9	8.6	\$1426

NOTES: Attachment bracket extends 2" into the worksurface. Brackets are Platinum only, no need to specify.

ⓘ Available in Frosted Translucent Acrylic ONLY HLSL2830.FT01.

HOW TO SPECIFY

<p>Select Model Number</p> <p>H M P C F S 3 6 2 0 .</p>	<p>Select Paint Color</p> <p>See page 478 \$4 upcharge for P2 Paints \$20 upcharge for P3 Paints</p> <p>T 1 .</p>	<p>Select Fabric</p> <p>See pages 476-477</p> <p>A P N 1 1</p>
<p>Select Model Number</p> <p>H M T L S C R N 2 0 5 4 .</p>	<p>Select Frame Paint</p> <p>P 8 T .</p>	<p>Select Bracket Paint</p> <p>P 8 T</p>

COORDINATE™ Accessories

GSA SIN AS NOTED



Icon Legend on page 19

WORKSTATIONS

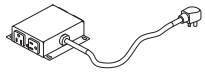

SIN 33721

DESCRIPTION

Under Worksurface Power Module – 4 Outlets, 10' Cord

- Includes 10' cord with three-prong plug.
- Fits in cable management troughs. See page 577.
- 4 outlets on side create easy access.

NOTES: Power Modules will also work with standing-height applications for 10500 Series™ and Voi® desks. For additional information see the Workplace Tools section in the 2021 Shared Spaces Pricer.

ⓘ Available in black finish only, no specification needed.

MODEL

HPWRMOD2

SHIP WEIGHT

1.5

CUBE

0.2

LIST PRICE

\$401

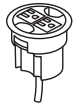

SIN 33721T

3" Round Power Grommet – 2 Outlets, 10' Cord

- Includes 10' cord with three-prong plug.
- Fits in 3" round grommet holes on the following product lines: Coordinate, Huddle, Motivate, all laminate and veneer casegoods series, and Systems Worksurfaces.
- Two grounded AC power outlets.
- Field installed with Plug-and-play ease.

NOTES: Power Modules will also work with standing-height applications for 10500 Series™ and Voi® desks.

ⓘ Available in black finish only, no specification needed.

MODEL

HGRMTAC2

1.5

0.2

\$148



SIN 33721

Flat Bracket

24"D

30"D

ⓘ Charcoal only.

ⓘ Must be used if specifying 2 worksurfaces for HHAB3S3L base.

HHN831124 ⓘ

3.0 ⓘ

0.3

\$64

HHN831130

3.0 ⓘ

0.4

\$64



OPEN MARKET

Wire Managers for Height Adjustable

Trough to Floor, 3" x 1½"

HMPHATFWML

2.0

0.3

\$251

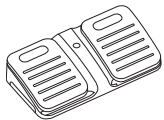

OPEN MARKET

Foot Control Pedal

HFTPDL

5.0

0.1

\$177

NOTES: Provides hands-free method for height adjustment. No specification needed. Pedal can be ordered with table or to retrofit on a current table.



Caster 4-Pack

ⓘ Field installable. Not available on model HHABETA2S2L. No specification needed.

HHABCSTRPK

1.0 ⓘ

0.1

\$75

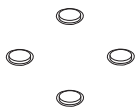

Slide Glide 4-Pack

ⓘ Field installable. When placed under base, allows table to be pushed/pulled to move. No specification needed.

HHABGLIDE

1.0 ⓘ

0.1

\$60

OPEN MARKET

HOW TO SPECIFY

Select
Model Number

HPWRMOD2



	DESCRIPTION	MODEL	SHIP WEIGHT	CUBE	LIST PRICE BY LAMINATE GRADE	
					L1	L2
	Rectangle Worksurfaces with External Stiffener					
	84"W x 24"D	HHAW2484PS	97	5.4	\$851	\$871
	96"W x 24"D	HHAW2496PS	100	5.7	\$890	\$910
	84"W x 30"D	HHAW3084PS	113	6.6	\$901	\$921
	96"W x 30"D	HHAW3096PS	116	7.0	\$940	\$960
	Rectangle Worksurfaces with External Stiffener, No Grommet					
	84"W x 24"D	HHAW2484PNS	97	5.4	\$851	\$871
	96"W x 24"D	HHAW2496PNS	100	5.7	\$890	\$910
	84"W x 30"D	HHAW3084PNS	113	6.6	\$901	\$921
	96"W x 30"D	HHAW3096PNS	116	7.0	\$940	\$960

NOTES:

❗ For use with Max Base, model HMREC3S2LTF, only.

LAMINATE

L1 LAMINATES CODES

Woodgrain

- ◆ Bourbon Cherry **H**
- ◆ Cognac **COGN**
- ◆ Florence Walnut **LFW1**
- ◆ Harvest **C**
- ◆ Kingswood Walnut **LKI1**
- ◆ Mahogany **N**
- ◆ Mocha **MOCH**
- ◆ Natural Maple **D**
- ◆ Pinnacle **PINC**
- ◆ Shaker Cherry **F**
- ◆ Sterling Ash **LSA1**

Solid

- ◆ Black **P**
- ◆ Charcoal **S**
- ◆ Designer White **LDW1**
- ◆ Loft **LOFT**

Patterned

- ◆ Sheer Mesh **A5**
- ◆ Silver Mesh **B9**
- ◆ Steel Mesh **A9**
- ◆ Canyon Zephyr **K9**
- ◆ Desert Zephyr **K8**
- ◆ Shadow Zephyr **K1**
- ◆ Gray **G2**
- ◆ Grey Tigris **L6**
- ◆ White **G1**
- ◆ Whitestone **K4**

L2 LAMINATES CODES

Woodgrain

- ◆ Lowell Ash **LLA1**
- ◆ Natural Recon **LNR1**
- ◆ Phantom Ecrú **LPE1**
- ◆ Portico Teak **LPT1**
- ◆ Skyline Walnut **LSW1**

EDGE

EDGE CODES

Woodgrain

- ◆ Bourbon Cherry **H**
- ◆ Cognac **COGN**
- ◆ Florence Walnut **FW**
- ◆ Harvest **C**
- ◆ Kingswood Walnut **KI**
- ◆ Light Gray **Q**
- ◆ Lowell Ash **DL**
- ◆ Mahogany **N**
- ◆ Mocha **MOCH**
- ◆ Natural Maple **D**
- ◆ Natural Recon **NR**
- ◆ Phantom Ecrú **PE**
- ◆ Pinnacle **PINC**
- ◆ Portico Teak **DP**
- ◆ Shaker Cherry **F**
- ◆ Skyline Walnut **SW**
- ◆ Sterling Ash **SA**

Solid

- ◆ Black **P**
- ◆ Charcoal **S**
- ◆ Designer White **DW**
- ◆ Greige **R**
- ◆ Loft **LOFT**
- ◆ Muslin **T**
- ◆ Platinum **K**

HOW TO SPECIFY

<p>Select Model Number</p> <p>HHAW3084PS</p>	<p>Select Laminate</p> <p>LKI1</p>	<p>Select Edge Color</p> <p>KI</p>	<p>Select Grommet Color</p> <p><i>Specify for worksurfaces with grommets only</i></p> <p>P Black S Charcoal Q Light Gray DW Designer White T5 Greige LOFT Loft T3 Muslin T1 Platinum</p> <p>P</p>
---	---	---	---

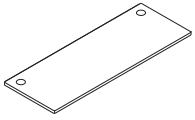

DESCRIPTION	MODEL	SHIP WEIGHT	CUBE	L1 LIST PRICE	L2 LIST PRICE
Systems Rectangle Worksurfaces for Height Adjustable Bases					
46"W x 23¼"D	HHAW2448P	58	3.3	\$429	\$444
52"W x 23¼"D	HHAW2454P	64	4.0	\$451	\$471
58"W x 23¼"D	HHAW2460P	70	4.0	\$499	\$519
64"W x 23¼"D	HHAW2466P	86	4.8	\$535	\$555
70"W x 23¼"D	HHAW2472P	89	4.8	\$552	\$572

Must be used as worksurfaces on Coordinate™ Height Adjustable Bases within Panel Systems, as these are 1" shorter in width on each side to provide clearance between panels and other worksurfaces.

Available in all standard systems' laminate and edgebanding options. Only offered with grommets.

Specify Model.LaminateColor.EdgeColor.GrommetColor SPECIFYING EXAMPLE: HHAW2448P.A5.K.T1

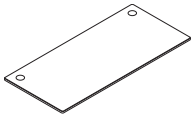

Systems Rectangle Worksurfaces for Height Adjustable Bases					
46"W x 29¼"D	HHAW3048P	68	4.0	\$458	\$473
52"W x 29¼"D	HHAW3054P	80	5.0	\$491	\$511
58"W x 29¼"D	HHAW3060P	101	5.0	\$544	\$564
64"W x 29¼"D	HHAW3066P	105	6.0	\$578	\$598
70"W x 29¼"D	HHAW3072P	105	6.0	\$616	\$636

Must be used as worksurfaces on Coordinate™ Height Adjustable Bases within Panel Systems, as these are 1" shorter in width on each side to provide clearance between panels and other worksurfaces.

Available in all standard systems' laminate and edgebanding options. Only offered with grommets.

Specify Model.LaminateColor.EdgeColor.GrommetColor SPECIFYING EXAMPLE: HHAW3048P.A5.K.T1

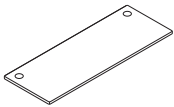

Voi® Rectangle Worksurfaces for Height Adjustable Bases					
48"W x 24"D	HLSLR2448	61	3.4	\$306	\$321
54"W x 24"D	HLSLR2454	68	4.2	\$330	\$350
60"W x 24"D	HLSLR2460	75	4.2	\$358	\$378
66"W x 24"D	HLSLR2466	82	5.0	\$389	\$409
72"W x 24"D	HLSLR2472	89	5.0	\$402	\$422
48"W x 30"D	HLSLR3048	75	4.2	\$330	\$345
54"W x 30"D	HLSLR3054	84	5.1	\$367	\$387
60"W x 30"D	HLSLR3060	92	5.1	\$410	\$430
66"W x 30"D	HLSLR3066	101	6.1	\$441	\$461
72"W x 30"D	HLSLR3072	110	6.1	\$480	\$500

For use with Coordinate™ Height Adjustable Bases only in Freestanding Applications, which are applications where the tables/desks are not attached or adjacent to another unit, table/desk or systems panel. The widths are true to stated dimensions. If used with Panel Systems or other than in Freestanding Applications, worksurfaces will not provide proper clearance between panels or other worksurfaces, and may cause injury or work surface damage (not covered by warranty).

Coordinate™ Height Adjustable Bases not compatible with 36"D rectangular worksurfaces.

See page 190 for specifying information.

NOTES:

- Systems Rectangle Worksurfaces for Height Adjustable Bases designed for use in panel systems. Work surface is 2" shorter in width and ¾" shorter in depth than standard worksurfaces to provide clearance between panels and other worksurfaces.

HOW TO SPECIFY

<p>Select Model Number</p>	<p>Select Laminate</p> <p>See page 455</p>	<p>Select Edge Color</p> <p>See page 455</p> <p>Specify for Systems Worksurfaces only</p>	<p>Select Grommet Color</p> <p>See page 455</p> <p>Specify for Systems Worksurfaces only</p>	<p>Select Grommet Option and Color</p> <p>Specify for Voi® Worksurfaces only</p> <p>X No Grommet G Grommet</p> <p>If choosing the grommet option</p> <p>Select Grommet Color</p> <p>P Black S Charcoal DW Designer White R Greige LOFT Loft T3 Muslin T1 Platinum SD Shadow</p>
<p>HHAW2448P</p> <p>HLSLR2448</p>	<p>A5</p> <p>NN</p>	<p>K</p>	<p>T1</p>	<p>GR</p>

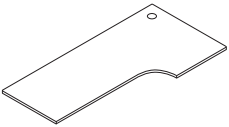
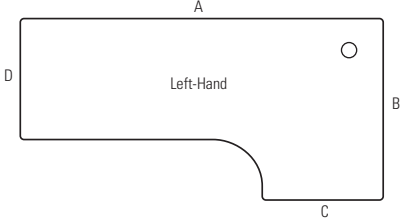
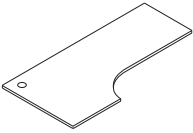
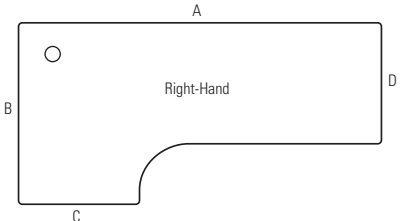

	DESCRIPTION	MODEL	SHIP WEIGHT	CUBE	L1 LIST PRICE	L2 LIST PRICE	
	Corner Cove Worksurfaces for Height Adjustable Bases, Left Hand						
	58" A x 34" B x 23" C x 23" D	HHAWV603624LP	67	6.1	\$606	\$631	
	70" A x 34" B x 23" C x 23" D	HHAWV723624LP	75	6.8	\$664	\$694	
	58" A x 46" B x 23" C x 23" D	HHAWV604824LP	85	7.4	\$664	\$694	
	58" A x 46" B x 29" C x 29" D	HHAWV604830LP	99	7.4	\$713	\$743	
	70" A x 46" B x 23" C x 23" D	HHAWV724824LP	105	8.8	\$830	\$865	
	70" A x 46" B x 29" C x 29" D	HHAWV724830LP	112	8.8	\$880	\$915	
							
		Corner Cove Worksurfaces for Height Adjustable Bases, Right Hand					
		58" A x 34" B x 23" C x 23" D	HHAWV603624RP	67	6.1	\$606	\$631
70" A x 34" B x 23" C x 23" D		HHAWV723624RP	75	6.8	\$664	\$694	
58" A x 46" B x 23" C x 23" D		HHAWV604824RP	85	7.4	\$664	\$694	
58" A x 46" B x 29" C x 29" D		HHAWV604830RP	99	7.4	\$713	\$743	
70" A x 46" B x 23" C x 23" D		HHAWV724824RP	105	8.8	\$830	\$865	
70" A x 46" B x 29" C x 29" D		HHAWV724830RP	112	8.8	\$880	\$915	
							

NOTES:

- Corner Cove Worksurfaces for Height Adjustable Bases designed for use in panel systems. Worksurface is 1" shorter in width and 1" shorter in depth on side of corner to provide clearance between panels and other worksurfaces.
- Use the 3-Leg Coordinate™ Base when specifying Coordinate™ Corner Cove Surfaces.

HOW TO SPECIFY

<p>Select Model Number</p> <p>HHAWV603624LP.</p>	<p>Select Laminate</p> <p>See page 455</p> <p>A5.</p>	<p>Select Edge Color</p> <p>See page 455</p> <p>K.</p>	<p>Select Grommet Color</p> <p>See page 455</p> <p>T1</p>
---	--	---	--

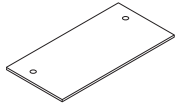

DESCRIPTION	MODEL	SHIP WEIGHT	CUBE	L1 LIST PRICE	L2 LIST PRICE
Concinnity™ Rectangle Worksurfaces					
48"W x 24"D	HNLRC2448	40	3.1	\$280	\$295
60"W x 24"D	HNLRC2460	50	3.9	\$333	\$353
66"W x 24"D	HNLRC2466	55	4.2	\$361	\$381
72"W x 24"D	HNLRC2472	60	4.6	\$374	\$394
48"W x 30"D	HNLRC3048	50	3.9	\$307	\$322
60"W x 30"D	HNLRC3060	62	4.7	\$376	\$396
66"W x 30"D	HNLRC3066	69	5.2	\$403	\$423
72"W x 30"D	HNLRC3072	75	5.6	\$438	\$458

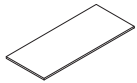

10500 Series™ Rectangle Worksurfaces					
48"W x 24"D	H105R2448	44	3.4	\$264	\$279
60"W x 24"D	H105R2460	55	4.2	\$311	\$331
66"W x 24"D	H105R2466	61	4.9	\$331	\$351
72"W x 24"D	H105R2472	66	4.9	\$342	\$362
48"W x 30"D	H105R3048	55	4.1	\$286	\$301
60"W x 30"D	H105R3060	69	5.2	\$349	\$369
66"W x 30"D	H105R3066	76	6.1	\$374	\$394
72"W x 30"D	H105R3072	83	6.1	\$402	\$422

NOTES:

- ❗ For use with Coordinate™ Height Adjustable Bases only in freestanding applications, which are applications where the tables/desks are not attached or adjacent to another unit, table/desk, or systems panel. The widths are true to stated dimensions. If used with Panel Systems or other than in freestanding applications, worksurfaces will not provide proper clearance between panels or other worksurfaces, and may cause injury or worksurface damage (not covered by warranty).
- ❗ Coordinate™ Height Adjustable Bases are not compatible with 36"D rectangular worksurfaces.

HOW TO SPECIFY

<p>Select Model Number</p> <p>For Concinnity™ Worksurfaces see page 29 For 10500 Series™ Worksurfaces see page 236</p> <p>H N L R C 2 4 4 8 . H 1 0 5 R 2 4 4 8 .</p>	<p>Select Worksurface Laminate and Edge Color</p> <p>B H . N N</p>	<p>Select Worksurface Grommet Finish</p> <p>Specify for Concinnity™ Worksurfaces only</p> <p>P Black T1 Platinum X No Grommet</p> <p>P .</p>	<p>Select Worksurface Color</p> <p>Specify for Concinnity™ Worksurfaces only. See page 29.</p> <p>H</p>
--	---	---	--



COORDINATE™ Shared Components

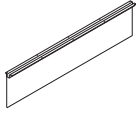

DESCRIPTION	MODEL	SHIP WEIGHT	CUBE	L1 LIST PRICE	L2 UPCHARGE
Laminate Floating Modesty Panel					
30"W x 14"H	HLSL3014L	10	0.8	\$173	\$10
36"W x 14"H	HLSL3614L	12	0.8	\$183	\$10
42"W x 14"H	HLSL4214L	14	0.8	\$195	\$10
48"W x 14"H	HLSL4814L	16	1.1	\$215	\$12
54"W x 14"H	HLSL5414L	18	1.1	\$235	\$12
60"W x 14"H	HLSL6014L	20	1.1	\$253	\$12

NOTES: The attachment bracket and modesty panel are packaged separately.
Specify: Model.Laminate.Paint

SPECIFYING EXAMPLE: HLSL3014L.N.P (Black is the only paint option for this model)

- ⓘ When specifying the 54"W or 60"W Laminate Floating Modesty Panel, it is not necessary to specify an external channel.
- ⓘ 30"W and 36"W screens attach with L-brackets, not the external channel.

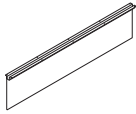

DESCRIPTION	MODEL	SHIP WEIGHT	CUBE	LIST PRICE
Mixed Material Floating Modesty Panel				
30"W x 14"H	HLSL3014MM	8	2.0	\$689
36"W x 14"H	HLSL3614MM	8	2.0	\$739
42"W x 14"H	HLSL4214MM	9	2.3	\$826
48"W x 14"H	HLSL4814MM	11	2.6	\$914
54"W x 14"H	HLSL5414MM	13	3.3	\$992
60"W x 14"H	HLSL6014MM	13	3.3	\$1134

NOTES: The attachment bracket and modesty panel are packaged separately.
Specify: Model.Mixed Material.Paint

SPECIFYING EXAMPLE: HLSL3014MM.FT01.P (Frosted Translucent mixed material and Black paint are the only options for this model)

- ⓘ When specifying the 54"W or 60"W Mixed Material Floating Modesty Panel, it is not necessary to specify an external channel.

NOTES:

- When using a floating modesty panel under the worksurface, the depth clearance for center drawers and keyboard platforms decreases by 8".

HOW TO SPECIFY

<p>Select Model Number</p> <p>H L S L 3 0 1 4 M M .</p>	<p>Select Mixed Material</p> <p>FT01 Frosted Translucent</p> <p>F T 0 1</p>
--	--

SYSTEMS Worksurface Supports

GSA SIN 33721



Icon Legend on page 19

WORKSTATIONS

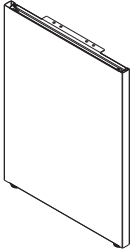

Specify paint

DESCRIPTION	MODEL	SHIP WEIGHT	CUBE	LIST PRICE BY PAINT GRADE	
				P1	P2
Abound® and Accelerate® Full End Panel*					
29½"H x 11"D — Right — Panel Mount	HRVEP1129R	16	1.4	\$207	\$236
29½"H x 11"D — Left — Panel Mount	HRVEP1129L	16	1.4	\$207	\$236
29½"H x 24"D — Right — Panel Mount	HRVEP2429R	21	1.4	\$223	\$252
29½"H x 24"D — Left — Panel Mount	HRVEP2429L	21	1.4	\$223	\$252
29½"H x 30"D — Right — Panel Mount	HRVEP3029R	23	1.4	\$242	\$271
29½"H x 30"D — Left — Panel Mount	HRVEP3029L	23	1.4	\$242	\$271

NOTES: The use of an end panel at the end of a worksurface will increase the rigidity of the workstation. If the panel is a greater dimension than the worksurface, an end panel is required if the run of the worksurfaces is 8 feet or greater. Levelers provide 1½" vertical adjustment.

- *Must be connected into panel slots. When an installation of worksurfaces is 8 feet or greater, a full end panel or universal support leg must be used at 90 degree panel junctions or in a shared position to support adjoining worksurfaces.
- End panel support with bracket will attach to both Accelerate® and Abound® panels.

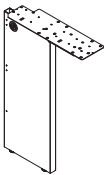

Non-handed unit
Specify paint

Abound® and Accelerate® Universal Support Leg*					
29½"H to support 24"D	HRVCLG24	16	1.4	\$197	\$226
29½"H to support 30"D	HRVCLG30	17	1.4	\$215	\$244

NOTES: Use at 90° panel junctions or in a shared position to support adjoining worksurfaces. Provided with flat bracket. Levelers provide 1½" vertical adjustment.

- *Must be connected into panel slots. When an installation of worksurfaces is 8 feet or greater, a full end panel or universal support leg must be used at 90 degree panel junctions or in a shared position to support adjoining worksurfaces.

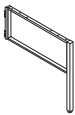

Open Leg Models*					
29½"H x 12"D	HOLEG12	7	0.5	\$147	\$176
29½"H x 24"D	HOLEG24	11	1.2	\$207	\$236
29½"H x 30"D	HOLEG30	15	1.8	\$225	\$254

NOTES: Open leg includes attaching hardware and leveling glides. Leveling glides provide 2¼" of adjustment. Open leg is universal shared with a left- and right-hand attachment bracket.

- *Must be connected into frame slots. Specify paint.

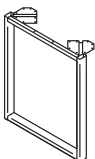

O-Leg Support for Worksurfaces					
20"D x 28½"H	HLSL2028O	15	3.7	\$298	\$302
24"D x 28½"H	HLSL2428O	17	3.7	\$324	\$328
30"D x 28½"H	HLSL3028O	19	5.4	\$359	\$363

NOTES: Ship fully assembled, 1/pack. Non-handed. Use the anti-dislodgement bracket when using a worksurface in a peninsula application with a post or O-leg.

DESCRIPTION	MODEL	SHIP WEIGHT	CUBE	LIST PRICE BY PAINT GRADE		
				P1	P2	P3
Voi® for Systems O-Leg-to-Panel Attachment Bracket						
Left handed bracket (quantity 1)	HLSLPBL	3	0.4	\$100	\$104	N/A
Right handed bracket (quantity 1)	HLSLPBR	3	0.4	\$100	\$104	N/A

NOTES: Used to connect Voi O-Leg to a systems panel for additional workstation rigidity. Bracket designed to work with edgeband worksurfaces only. Brackets are handed, come one per package and include self-tapping screws. Specify paint.

NOTES:

- The supports included on this page can be used with Systems and Worksurfaces.

HOW TO SPECIFY

<p>Select Model Number</p> <p>HRVEP1129R.</p>	<p>Select Paint Color</p> <p>See page 173</p> <p>T1</p>
---	---



SYSTEMS Worksurface Supports

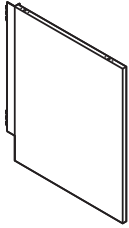

DESCRIPTION	MODEL	SHIP WEIGHT	CUBE	LIST PRICE BY PAINT GRADE	
				P1	P2
Laminate End Panel Support with Panel Bracket					
29½”H x 24”D, Left handed	HLSL2428EBL	3	2.2	\$263	\$267
29½”H x 24”D, Right handed	HLSL2428EBR	3	2.2	\$263	\$267
29½”H x 30”D, Left handed	HLSL3028EBL	3	3.2	\$280	\$284
29½”H x 30”D, Right handed	HLSL3028EBR	3	3.2	\$280	\$284

NOTES: Includes laminate end panel and brackets to attach end panel support to a panel. Order to correspond to worksurface depth. Specify laminate and paint. Can be used with Abound® and Accelerate® Systems products.

NOTES:

- The supports included on this page and on previous page can be used with Systems and Worksurfaces.

HOW TO SPECIFY

<p>Select Model Number</p> <p>H L S L 2 4 2 8 E B L .</p>	<p>Select Laminate</p> <p>L2 Laminate Upcharge \$10 See page 455</p> <p>H .</p>	<p>Select Paint Color</p> <p>See page 455</p> <p>T 1</p>
--	--	---

SYSTEMS

Worksurface Supports

GSA SIN 33721



Icon Legend on page 19

WORKSTATIONS

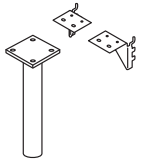

Non-handed unit
Specify paint

DESCRIPTION	MODEL	SHIP WEIGHT	CUBE	LIST PRICE BY PAINT GRADE	
				P1	P2
Support Column* For 29½" Height. 3" diameter. NOTES: Used to support one end of a peninsula, round or half-round worksurface. (Includes panel support brackets.) Levelers provide 1½" vertical adjustment. ! *Brackets must be connected into panel slots.	HCNLEG29	13 Ⓞ	1.1	\$217	\$244



Post Leg Base • Single Post Leg with Hardware Pack • Requires hardware bracket model HWSA2. Please see below for HWSA2 bracket ordering information.	HMBPOST1	18	2.3	\$294	\$306
---	-----------------	----	-----	--------------	--------------

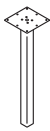

Post Leg Base 28½"H x 2" square NOTES: Requires hardware bracket model HWSA2 when used to support a peninsula.	HLSL28P	15	1.0	\$298	\$302
---	----------------	----	-----	--------------	--------------

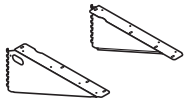

Specify paint

Accessory Cantilever* 18"D Pair 24"D Pair 18"D Right-Hand Cantilever 18"D Left-Hand Cantilever 24"D Right-Hand Cantilever 24"D Left-Hand Cantilever	HCTL182 HCTL242 Ⓞ HCTL181R HCTL181L HCTL241R HCTL241L	4 Ⓞ 5 Ⓞ 3.2 Ⓞ 3.2 Ⓞ 3.7 Ⓞ 3.7 Ⓞ	0.3 0.3 0.2 0.2 0.6 0.6	\$66 \$83 \$35 \$35 \$45 \$55	\$76 \$93 \$45 \$45 \$55 \$55
--	--	--	--	--	--

- ! *Must be connected into panel slots.
- ! Accelerate® only: Cantilevers only to be used on worksurface runs 72"W or less.
- ! Use with runs 72" or less – avoid installation on only one side of a straight connection except to support corner worksurfaces. Floor support is required for runs longer than 72".
- ! DO NOT position at the end of a panel run where no 90 degree return panel is positioned.
- ! DO NOT use to support worksurfaces from which a hanging pedestal is suspended, or to which a peninsula worksurface is attached.
- ! DO NOT use cantilever brackets to support worksurfaces supported with permanent wall hanger kit.

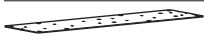

Flat Bracket 18"D 24"D 30"D	HHN831118 HHN831124 Ⓞ HHN831130	3 Ⓞ 3 Ⓞ 3 Ⓞ	0.2 0.3 0.4	\$63 \$64 \$64	N/A N/A N/A
---	--	-------------------	-------------------	---	-------------------

NOTES: Flat Brackets can be used to connect one worksurface perpendicular to another worksurface.

- ! Charcoal only.

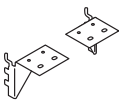

Specify paint

Worksurface Bracket Kit* One Pair	HWSB2	1 Ⓞ	0.1	\$47	\$50
---	--------------	-----	-----	-------------	-------------

NOTES: Used to connect the end of a worksurface to a panel of the same width.
 ! Always use when the depth side of a worksurface is against a panel (return/wing panel) of the same dimension. This will increase the sturdiness of the workstation.

- ! *Must be connected into panel slots.



Anti-Dislodgement Bracket Kit	HWSA2	1	0.1	\$45	\$48
--------------------------------------	--------------	---	-----	-------------	-------------

NOTES: To be used with models HMBPOST1 and HLSL28P Post Leg Base.

NOTES:







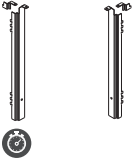

- The supports included on this page can be used with Systems Worksurfaces.

HOW TO SPECIFY

Select Model Number H C T L 2 4 2 .	Select Paint Color T 1 See page 455
---	--



WORKSURFACE BRACKETS

	DESCRIPTION	MODEL	SHIP WEIGHT	CUBE	LIST PRICE BY PAINT GRADE		
					P1	P2	P3
	Flagship® Pedestal to Panel Bracket Kit, Left	HPD2PNBRK2L	3.0 	0.3	\$110	\$118	\$120
	Flagship® Pedestal to Panel Bracket Kit, Right	HPD2PNBRK2R	3.0 	0.3	\$110	\$118	\$120
NOTES: Bracket to attach 22 ⁷ / ₈ "D pedestals to 24"D worksurface or 28 ⁷ / ₈ "D pedestals to 30"D worksurface.							
	Worksurface to Tower Bracket Kit						
	Bracket to attach storage towers to worksurfaces.	HSTB2W1	4.0 	0.6	\$79	\$92	\$94
NOTES: Replaces the need for a panel attached end panel. Standard with hardware to attach bracket to panel and worksurface.							
 Bracket cannot be used as a support when placing Stack-on Storage on worksurface over bracket. Must use two full-sized supports when using Stack-on Storage.							
 Not for use with systems support pedestals.							
	Worksurface-to-Wing Panel Bracket						
	24"W	HWSR24	2.5	0.4	\$58	N/A	N/A
	30"W	HWSR30	3.0	0.4	\$58	N/A	N/A
	36"W	HWSR36	3.5	0.5	\$58	N/A	N/A
	42"W	HWSR42	4.0	0.5	\$58	N/A	N/A
	48"W	HWSR48	4.5	0.6	\$58	N/A	N/A
NOTES:							
• To be used when the adjacent wing panel is wider than the worksurface depth.							
• Specify support to the same width as your adjacent wing panel, not the depth of your worksurface.							
• Support spans the entire width of the wing panel.							
• Supports are non-handed.							

HOW TO SPECIFY

<p>Select Model Number</p> <p>HPD2PNBRK2L . T1</p>	<p>Select Paint Color</p> <p>See page 455</p>
--	---

SYSTEMS

Worksurface Supports

GSA SIN 33721



Icon Legend on page 19

WORKSTATIONS

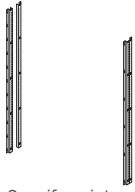

Specify paint

DESCRIPTION	MODEL	SHIP WEIGHT	CUBE	LIST PRICE BY PAINT GRADE	
				P1	P2
Abound® and Accelerate® Permanent-Wall Hanger Kit Wall Hanger Kit (2 pieces) 2½"W x ⅞"D x 66"H	HRVC35PCE	6	0.7	\$220	\$240
Wall Hanger Kit 4¼"W x ⅞"D x 66"H	HRVC35PCM	3	0.7	\$115	\$125

NOTES: Anchor devices are not supplied with these models. Refer to Abound® or Accelerate® Installation instructions for appropriate hardware. Used to hang storage cabinets and bookshelves from permanent wall, and/or to attach worksurfaces to permanent wall.

- ⓘ Attachment to masonry walls is not recommended.
- ⓘ Worksurfaces should not be supported with Cantilever brackets when using Permanent-Wall Hanger Kit.

NOTES:

- Wall track has ⅛" x ½" slots on 1" centers.
- Customer to furnish connecting hardware. (Refer to Installation Instructions for appropriate hardware.)
- Includes a cover for top of channel.

HOW TO SPECIFY

<p>Select Model Number</p> <p>HRVC35PCE</p>	<p>Select Paint Color</p> <p>See page 455</p> <p>T1</p>
---	---



STANDING-HEIGHT WORKSURFACE SUPPORTS

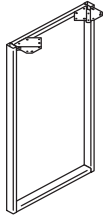

DESCRIPTION

Standing-Height O-Leg Support for Worksurfaces

24"D x 41"H
30"D x 41"H

NOTES: Ship fully assembled, 1/package. Non-handed.

MODEL	SHIP WEIGHT	CUBE	LIST PRICE BY PAINT GRADE	
			P1	P2
HLSL2441O	16	5.3	\$433	\$439
HLSL3041O	17	6.5	\$485	\$491

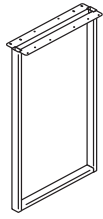

Standing-Height O-Leg Shared Support for Worksurfaces

24"D x 41"H
30"D x 41"H

NOTES: Ship fully assembled, 1/package. Non-handed.

HLSL2441SL	16	5.3	\$488	\$494
HLSL3041SL	17	6.5	\$540	\$546

NOTES:

- O-leg glides have 2" adjustability.
- Shared O-legs create a cleaner aesthetic in all applications where two legs are used side-by-side.
- O-Leg to Panel Attachment Brackets are used to connect Voi® O-Legs to a systems panel for additional worksurface rigidity.

! O-legs may only be attached to worksurfaces, not storage units.

HOW TO SPECIFY

<p>Select Model Number</p> <p>H L S L 2 4 4 1 O</p>	<p>Select Paint Color</p> <p>See page 173</p> <p>T 1</p>
--	---

SYSTEMS

Standard Height Support Pedestals

GSA SIN 33721



Icon Legend on page 19

WORKSTATIONS

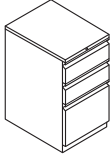

DESCRIPTION

Standard Height Freestanding Support Pedestals — Box/Box/File
 15"W x 19⁷/₈"D x 28"H
 15"W x 22⁷/₈"D x 28"H

MODEL

HVFB20R
HVFB23R

SHIP WEIGHT

89.0
 95.0

CUBE

7.0
 8.0

LIST PRICE BY PAINT GRADE

P1	P2	P3
\$540	\$568	\$584
\$556	\$584	\$601

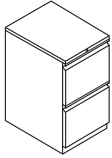

Standard Height Freestanding Support Pedestals — File/File
 15"W x 19⁷/₈"D x 28"H
 15"W x 22⁷/₈"D x 28"H

HVFF20R
HVFF23R

88.0
 94.0

7.0
 8.0

P1	P2	P3
\$535	\$563	\$579
\$551	\$579	\$596

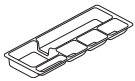

Optional Pencil Tray

HV-UT1

0.5

0.1

\$69

N/A

N/A

NOTES: For additional information see the Workplace Tools section in the 2021 Shared Pricer.

For use with mobile and freestanding pedestal models shown above.

NOTES:

- 28"H fits under all HON worksurfaces and desk shells.
- Ball-bearing suspension on file drawer (90% extension), and box drawer (90% extension on both drawers).
- File drawers have high sides for filing front-to-back.
- Available in "R" pull only.
- Pencil tray standard in top box drawer.
- One box divider standard in each box drawer.
- One crossrail standard in each file drawer.

Freestanding models must be used under a worksurface only.

HOW TO SPECIFY

<p>Select Model Number</p> <p>H V F B 2 0 R .</p>	<p>Select Lock Option</p> <p>L Lock (no upcharge)</p> <p>L .</p>	<p>Select Paint Color</p> <p>See page 455</p> <p>P</p>
--	---	---

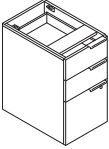
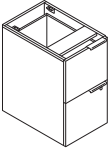
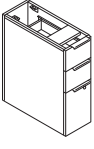

Laminate Support Pedestals

	DESCRIPTION	MODEL	SHIP WEIGHT	CUBE	L1 LIST	L2 UPCHARGES	
						CHASSIS	FRONTS
	Support Pedestals — Box/Box/File						
	16"W x 20"D x 28½"H	HLSL2028B	73	7.3	\$704	\$15	\$10
	16"W x 24"D x 28½"H	HLSL2428B	85	8.5	\$778	\$20	\$10
	16"W x 30"D x 28½"H	HLSL3028B	105	10.5	\$876	\$25	\$10
	NOTES: Top box drawer does not lock.						
	Support Pedestals — File/File						
	16"W x 20"D x 28½"H	HLSL2028F	72	7.3	\$704	\$15	\$10
	16"W x 24"D x 28½"H	HLSL2428F	84	8.5	\$778	\$20	\$10
	16"W x 30"D x 28½"H	HLSL3028F	104	10.5	\$876	\$25	\$10
	Slim Profile Pedestals — Box/Box/File						
	9½"W x 24"D x 28½"H	HLSL2428S	69	6.9	\$772	\$20	\$10
	9½"W x 30"D x 28½"H	HLSL3028S	56	5.6	\$848	\$25	\$10
	NOTES: Top box drawer does not lock.						

NOTES:

- Please see Voi® section of the pricer for full Voi® laminate offering, which is compatible with all HON systems series.
 - Voi® Support and Power-Ready Pedestals can be used with worksurfaces.
 - A variety of pedestals, end panels, and O-legs can be combined to create a conventional or contemporary desk.
 - Chassis and drawer front woodgrain and solid laminates are specified separately (see SIF options below).
 - File drawers accept hanging folders in letter or legal size.
 - Multiple handle locations possible per customer preference.
 - Ships with one handle per drawer.
 - Drawer Organizer model HLSDRWORG works with box drawers.
 - Box and file drawers operate on ball-bearing suspension with full extension.
 - Adjustable hex leveling glides allow floor-standing furniture to be easily leveled without lifting the unit; glides have 1¼" adjustable range.
- ① Pedestals ship fully assembled but must attach to a worksurface with a quick release bracket, provided. Pedestals are non-handed and are interchangeable.
- ① Locking units equipped with HON "One Key" interchangeable core removable locks. Keyed alike core must be ordered separately.

HOW TO SPECIFY

<p>Select Model Number</p> <p>H L S L 2 0 2 8 B .</p>	<p>Select Chassis Laminate</p> <p>See page 173</p> <p>N .</p>	<p>Select Drawer Front Laminate</p> <p>See page 173</p> <p>N .</p>	<p>Select Pull Color</p> <p>P Black T4 Champagne T1 Platinum PJW Designer White PR6 Silver P8X Solar Black</p> <p>T 4</p>
--	--	---	---

VOI® Laminate Support Storage

GSA SIN 33721



Icon Legend on page 19

WORKSTATIONS

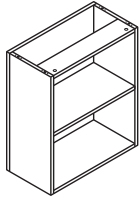

DESCRIPTION

Bookcase Support
24"W x 12"D x 28½"H
30"W x 12"D x 28½"H

MODEL	SHIP WEIGHT	CUBE	L1 LIST	L2 UPCHARGES	
				CHASSIS	FRONTS
HLSL240BC	60	3.0	\$522	\$20	N/A
HLSL300BC	75	3.0	\$546	\$25	N/A

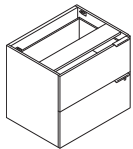

Lateral File — 2 Drawer
31⅜"W x 24"D x 28½"H

HLSL2430L	121	15.6	\$1207	\$35	\$20
------------------	-----	------	---------------	-------------	-------------

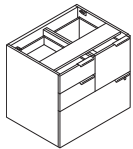

Multi File Lateral File
31⅜"W x 24"D x 28½"H
NOTES: Box drawers do not lock.

HLSL2430MF	163	15.6	\$1433	\$35	\$20
-------------------	-----	------	---------------	-------------	-------------

NOTES:

- Voi® Support and Power-Ready Storage can be used with Systems Worksurfaces.
- Ships with one handle per drawer on all units.
- A variety of pedestals, end panels, and O-legs can be combined to create a conventional or contemporary desk.
- Bookcase can only mount exterior facing under a worksurface.
- Chassis and drawer front woodgrain and solid laminates are specified separately (see SIF options below).
- File drawers accept hanging folders in letter or legal size.
- Multiple handle locations possible per customer preference.
- Storage accessory model HLSLDRWORG works with box doors.
- Standard box drawers operate on ball-bearing suspension with full extension. File, lateral, and wide box drawers operate on ball-bearing suspension with full extension.
- Adjustable hex leveling glides allow floor-standing furniture to be easily leveled without lifting the unit; glides have 2" adjustable range.
- When using two lateral files, a 60" worksurface cannot be used, a 66" worksurface must be specified, which will show a gap.

- ❗ Cannot fit binders on both shelves of bookcase model HLSL240BC and HLSL300BC.
- ❗ Must be specified under a worksurface 60"W or wider.
- ❗ Locking units equipped with HON "One Key" interchangeable core removable locks. Keyed alike core must be ordered separately.

HOW TO SPECIFY

<p>Select Model Number</p> <p>H L S L 2 4 3 0 L .</p>	<p>Select Chassis Laminate</p> <p>See page 173</p> <p>N .</p>	<p>Select Laminate</p> <p>See page 173</p> <p>N .</p>	<p>Select Pull Color</p> <p>P Black T4 Champagne T1 Platinum PJW Designer White PR6 Silver P8X Solar Black</p> <p>T 4</p>
--	--	--	--

	DESCRIPTION	MODEL	SHIP WEIGHT	CUBE	LIST PRICE BY PAINT GRADE		
					P1	P2	P3
	Paper Management Support Bars						
	24"W x 5"H	HNPMBSW24	1.3	0.4	\$196	\$208	\$218
	30"W x 5"H	HNPMBSW30	1.5	0.5	\$209	\$221	\$231
	36"W x 5"H	HNPMBSW36	2.0	0.6	\$216	\$228	\$238
	42"W x 5"H	HNPMBSW42	5.0	0.7	\$228	\$240	\$250
	48"W x 5"H	HNPMBSW48	7.0	0.8	\$237	\$249	\$259
	60"W x 5"H	HNPMBSW60	9.0	0.9	\$269	\$281	\$291
	Recommended weight capacity not to exceed 80 pounds. Paper management bar attaches to Systems panels/frames to accommodate work flow accessories.						
	Paper Shelf 15"W x 9½"D x 2"H	HPPMPS	2.0	0.3	\$99	\$111	\$122
	NOTES: Holds letter size paper and inter-office envelopes.						
	Accessory Shelf 21¾"W x 7"D x 2"H	HPPMAS	2.0	0.3	\$103	\$115	\$126
	NOTES: Holds office supplies and personal effects.						
	Phone Tray 9"W x 10¾"D x 2"H	HPPMPT	2.0	0.3	\$126	\$138	\$149
	NOTES: Holds telephone at optimum ergonomic angle.						
	CD/Pencil Holder 5¼"W x 1½"D x 5"H	HPPMPB	1.0	0.2	\$103	\$115	\$126
	NOTES: Can store up to 3 CD jewel cases; sticky pads or writing instruments.						
	Sorter Tray 6"W x 10"D x 2½"H	HPPMST	2.0	0.3	\$135	\$147	\$158
	NOTES: Provides 3 slots for organizing files.						
	Folder Bin 12¼"W x 1¼"D x 9"H	HPPMFB	2.0	0.3	\$103	\$115	\$126
	NOTES: Accommodates manila envelopes and can be hung from other folder binds to maximize storage.						
	DESCRIPTION	MODEL	SHIP WEIGHT	CUBE	LIST PRICE		
	Markerboards						
	36"W x 24"H	HHMRK36	15.0	3.2	\$510		
	42"W x 24"H	HHMRK42	17.0	4.0	\$553		
	48"W x 24"H	HHMRK48	19.0	4.6	\$595		
	No color specification required.						
	Back Pack Hook (10 per carton) 12"W x 14½"D x 1½"H	HCLA65	10.0	0.1	\$95		
	NOTES: Assembly; attaches to bottom of desk with (2) screws, included.						
	Available in Titanium finish only, no specification needed.						
OPEN MARKET 							

HOW TO SPECIFY

Select Model Number H N P M B S W 2 4	Select Paint Color See page 455 P 8 S
---	--

SYSTEMS

Accessories — Task Lights

GSA SIN 33721



Icon Legend on page 19

WORKSTATIONS



DESCRIPTION

Articulating Desk Lamp Articulating Desk Lamp w/ Occupancy Sensor

- Color: Matte Silver.
- Full-range dimming from 10% to 100%.
- Designed for 50,000 hours of life.
- Occupancy sensor is built into the head of the lamp and will automatically shut the lamp off after 6 minutes of undetected movement.
- Base swivel is 180 degrees.
- Uses only 5 watts of energy.
- Light comes with a silver 9' 4" power cord.
- Base diameter is 7.5".
- 3500K Color Temperature.
- 80 Color Rendering Index.
- TAA Compliant.

MODEL SHIP WEIGHT CUBE LIST PRICE

HLED1	1.2	6.5	\$402
HLED1OC	1.2	6.5	\$490



Task Desk Lamp

- Color: Brushed Nickel.
- Full-range dimming from 10% to 100%.
- Designed for 50,000 hours of life.
- Lamp is 15.83" tall.
- Desk lamp does not articulate at base. The pivoting head provides custom positioning, as it can be twisted 360 degrees.
- Uses only 5 watts of energy.
- Light comes with a silver 9' 4" power cord.
- Base diameter is 6.7".
- 3500K Color Temperature.
- 80 Color Rendering Index.
- TAA Compliant.

HLED2	0.7	3.0	\$348
--------------	-----	-----	--------------

NOTES:

- For additional information see the Workplace Tools section in the 2021 Shared Spaces Pricer.





HOW TO SPECIFY

Select
Model Number

HLED1

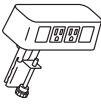
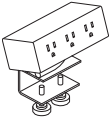
SYSTEMS

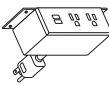
Accessories — Electrical

	DESCRIPTION	MODEL	SHIP WEIGHT	CUBE	LIST PRICE
	<p>Power & Data Center</p> <p>2 Receptacles 2 Data Accessory</p> <ul style="list-style-type: none"> Standard with two receptacles and openings for two data ports. 6' power cord with standard three-prong plug. Fits on any worksurface with a 4" overhang. UL Listed. <p>! Color finish coordinates with HON's Loft. <i>Specify LOFT when ordering. Example: HCOMDOME2.LOFT</i></p>	HCOMDOME2	2.5 \$	0.2	\$296
	<p>Power Modules</p> <p>3 Receptacles with Worksurface Clamp</p> <p>3 Receptacles with Under-Worksurface Mounting Bracket</p> <p>2 Receptacles 2 USB with Worksurface Clamp</p> <p>2 Receptacles 2 USB with Under-Worksurface Mounting Bracket</p> <ul style="list-style-type: none"> 6' power cord with standard three-prong plug. Under-worksurface mounting bracket models work with any top that has a 5" x 5" square clearance. Worksurface clamp models work on any top with a 4" overhang. UL Listed. <p>! Color finish coordinates with HON's Charcoal or White. <i>Specify STRM for Storm and SNW for Snow when ordering. Example: HPWRMOD3WC.STRM</i></p>	<p>HPWRMOD3WC </p> <p>HPWRMOD3UWM</p> <p>HPWRMOD2WC </p> <p>HPWRMOD2UWM</p>	<p>2.3 \$</p> <p>2.3 \$</p> <p>2.3 \$</p> <p>2.3 \$</p>	<p>0.2</p> <p>0.2</p> <p>0.2</p> <p>0.2</p>	<p>\$310</p> <p>\$310</p> <p>\$496</p> <p>\$496</p>
	<p>Under Worksurface Power Module — 4 Outlets, 10' Cord</p> <ul style="list-style-type: none"> Includes 10' cord with three-prong plug. Fits in cable management troughs. See page 577. 4 outlets on side create easy access. <p>NOTES: Power Modules will also work with standing-height applications for 10500 Series™ and Voi® desks.</p> <p>! Available in black finish only, no specification needed.</p>	HPWRMOD2	1.5	0.2	\$401
	<p>Vertebrae</p> <p>NOTES: 30"H x 3 1/8"W x 1 1/2"D. Ships unassembled.</p> <p>! Clear finish. Specify "X" for finish option.</p> <p>SPECIFYING EXAMPLE: HMPVWM28.X</p>	HMPVWM28	3.0	0.3	\$223

NOTES:

- For additional information see the Workplace Tools section in the 2021 Shared Spaces Pricer.

SYSTEMS

Accessories — Monitor Arms

OPEN MARKET EXCEPT AS NOTED



Icon Legend on page 19

WORKSTATIONS

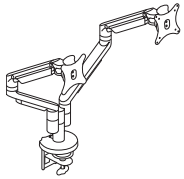

DESCRIPTION

Dual Dynamic Monitor Arm

- 150° of rotation at base with optional 360° rotation.
- Arms extend 22" and retract up to 3".
- Monitor mount rotates 180° and tilts +/-30°.
- Monitor can be rotated from landscape to portrait position.

! Arms hold monitors from 6.2-18 lbs. Optional counterweight HPACW available to support monitors as low as 5 lbs. (see the Workplace Tools section in the 2021 Shared Spaces Pricer).

MODEL	SHIP WEIGHT	CUBE	LIST PRICE
HMASD	17.0 ☹	1.1	\$900

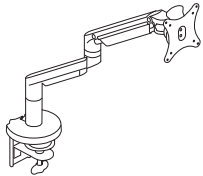

Single Dynamic Monitor Arm

- 180° of rotation at base with optional 360° rotation.
- Arms extend 22" and retract up to 3".
- Monitor mount rotates 180° and tilts +/-30°.
- Monitor can be rotated from landscape to portrait position.

! Arms hold monitors from 6.2-18 lbs. Optional counterweight HPACW available to support monitors as low as 5 lbs. (see the Workplace Tools section in the 2021 Shared Spaces Pricer).

HMASTS	11.5 ☹	0.8	\$468
---------------	--------	-----	--------------

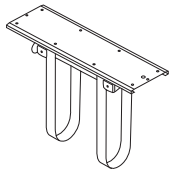

360° Swivel CPU Holder with Adjustable Straps

- Supports CPUs 3¾" wide up to 64" perimeter and holds up to 75 lbs.
- 360° rotation.
- Ships complete and includes necessary mounting hardware and instruction sheet.

! Available in Black only, no specification needed.

HCPUI	7.0 ☹	0.2	\$243
--------------	-------	-----	--------------

SIN 33721

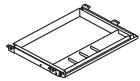

Polymer Center Drawer

- Color: Black.
- Material: ABS.
- Minimum clearance for mounting: 23"W x 16¼"D x 2"H.
- Retracts on 16" ball-bearing slides.
- Can be used on worksurfaces with Coordinate™ Height Adjustable Bases as long as it is attached with spacer model HKBS.
- Can store up to 25 lbs.

! Black finish only, no specification needed.

HCD1	7.0	0.5	\$111
-------------	-----	-----	--------------

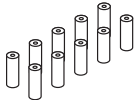

Keyboard Spacer

- For use when attaching a keyboard tray to Coordinate™ and Voi® or Systems Worksurface with an external channel.
- The kit includes ten cylinder spacers and ten screws.
- Spacers are ¾"W x 2½"H.
- Specify one kit per keyboard tray.

NOTES: For additional information see the Workplace Tools section in the 2021 Shared Spaces Pricer.

HKBS	1.0 ☹	0.8	\$92
-------------	-------	-----	-------------

NOTES:

- See the Workplace Tools section in the 2021 Shared Spaces Pricer for additional monitor arm models.

HOW TO SPECIFY

<p>Select Model Number</p>	<p>Select Finish</p> <p><i>Specify for models HMASD and HMASTS only</i></p> <p>SVR Silver BLK Black</p>
<p>HMASD.</p>	<p>SVR</p>

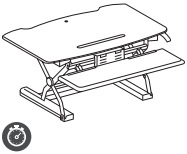
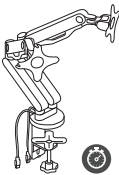
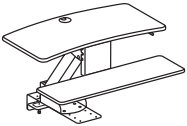
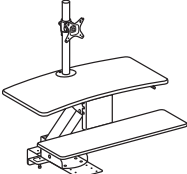
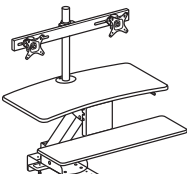
	DESCRIPTION	MODEL	SHIP WEIGHT	CUBE	LIST PRICE
	<p>Coordinate™ Portable Desktop Riser 31"D x 5"-16½"H x 35"W</p> <p>NOTES: Available in Black (BLK) or White (WHT) finish. Desktop riser dimensions (without keyboard tray): 22"D x 5"-16½"H x 35"W. Keyboard tray dimensions: 9"D x 30"W. Max loading capacity is 33 lbs for the desktop riser surface and 4 lbs for the keyboard tray. Easily transition from seated to standing positions throughout the workday. Sits atop an existing desk to create sit-to-stand functionality by raising the computer. Includes keyboard tray and surface for computer monitors. HON 5-Year Limited Warranty.</p> <p>⚠ Not intended for use on mobile workstations.</p>	HBXRISER	54.0	4.1	\$619
	<p>Dual Monitor Arm with 2 USB Ports</p> <p>NOTES: Easy adjustment. Height adjusts to 17" tall. Monitor tilt and swivel capability. Enclosed cable management. Grommet or desktop mounting. Clean appearance. In some applications the Monitor Arms may extend 12 or more inches into the worksurface. For additional information see the Workplace Tools section in the 2021 Shared Spaces Pricer. HON 5-Year Limited Warranty.</p> <p>⚠ No specification needed.</p> <p>⚠ Cannot be used with Empower® height adjustable models.</p>	HBDMAUSB	41.9	2.6	\$383
	<p>Coordinate™ Mounted Desktop Riser</p> <p>NOTES: Does not include a monitor arm and is suitable for laptops and/or monitors on their original stands.</p> <p>⚠ No specification needed.</p>	HS1100	60.0 Ⓞ	3.2	\$664
	<p>Coordinate™ Mounted Desktop Riser with Single Monitor Arm</p> <p>NOTES: Includes a monitor arm for a single monitor.</p> <p>⚠ No specification needed.</p>	HS1101	62.0 Ⓞ	3.2	\$777
	<p>Coordinate™ Mounted Desktop Riser with Dual Monitor Arm</p> <p>NOTES: Includes a monitor arm for dual monitors.</p> <p>⚠ No specification needed.</p>	HS1102	63.0 Ⓞ	3.2	\$883

NOTES FOR HS1100, HS1101, HS1102:

- These products are designed to allow the user to transition from seating position to standing position throughout the workday.
- Gas-assist lever-operated mechanism with positive stop.
- Clamp mount compatible with worksurfaces depths of 20"-30". 20" is for systems only.
- Clamp requires 3.5" of clearance along back edge of worksurface.
- Black seamless worksurfaces.
- Silver powder coated metal components.
- Lowers below worksurface level on 24" and 30"D worksurfaces.
- All models contain a large primary worksurface and a smaller keyboard / mouse surface.
- Beveled edges for sleek appearance and comfort while typing.
- Monitor arms include height, width, and swivel adjustment.

- Not for use under overhead storage, with flush mounted modesty panels, or worksurfaces thinner than 1".

⚠ Not recommended for use on mobile (castered) worksurfaces.

MOUNTING AND COMPATIBILITY FOR HS1100, HS1101, HS1102:

- This product is intended to be installed on commercial-grade worksurfaces in good condition.
- Compatible with freestanding worksurfaces 24"-30"D or panel-supported worksurfaces 24"-30"D.
- Not for use on mobile worksurfaces.

Clamp Mount

Use when 3.5" minimum overhang is available

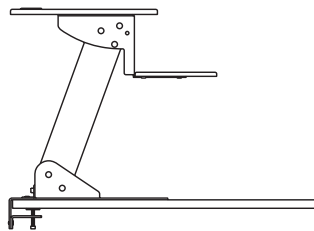

Screw Mount

Use when no overhang is available. Worksurface must be minimum 1" thick.

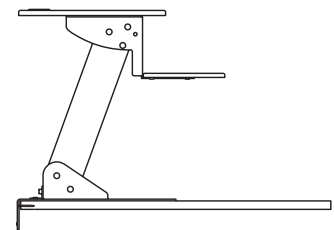

HOW TO SPECIFY

<p>Select Model Number</p> <p>HBXRISER</p>	<p>Select Finish</p> <p>BLK Black WHT White</p> <p>BLK</p>
---	---



SYSTEMS Accessories

OPEN MARKET



Icon Legend on page 19

WORKSTATIONS

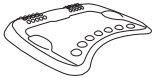
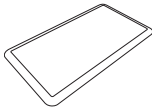
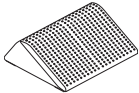
	DESCRIPTION	MODEL	SHIP WEIGHT	CUBE	LIST PRICE
	Rectangle Wobble Board — Anti-Fatigue Mat 18"D x 3"H x 22¼"W ⓘ Available in Black (T) finish ONLY. Recommended weight capacity not to exceed 250 pounds. HON 5-Year Limited Warranty. SPECIFYING EXAMPLE: HVL981.T	HVL981 ⓘ	10.0 Ⓔ	0.9	\$121
	Round Wobble Board — Anti-Fatigue Mat 18½"D x 2½"H x 18½"W ⓘ Available in Black (T) finish ONLY. Recommended weight capacity not to exceed 250 pounds. HON 5-Year Limited Warranty. SPECIFYING EXAMPLE: HVL982.T	HVL982 ⓘ	5.8 Ⓔ	0.6	\$103
	Ergonomic Anti-Fatigue Mat 25"D x 2¾"H x 29⅞"W ⓘ Available in Black ONLY. No specification needed. SPECIFYING EXAMPLE: HBEAFM1	HBEAFM1	7.0	1.4	\$219
	Rectangle Anti-Fatigue Mat 20"D x ¾"H x 36"W ⓘ Available in Black ONLY. No specification needed. SPECIFYING EXAMPLE: HBAFM2036	HBAFM2036 ⓘ	5.4	0.4	\$100
	Footrest — Anti-Slip Cover 13¾"D x 5½"H x 16"W ⓘ Available in Black (T) finish ONLY. Recommended weight capacity not to exceed 250 pounds. HON 5-Year Limited Warranty. SPECIFYING EXAMPLE: HVL991.T — isolated, dedicated circuit	HVL991	7.0 Ⓔ	0.9	\$82

NOTES:

ⓘ Discontinued 1/1/21.

HOW TO SPECIFY

Select Model Number H V L 9 8 1 .	Select Finish T Black
---	---------------------------------



Versé® Panels shown with SmartLink® Value Mobile Storage, Between™ Multi-Purpose Table, Motivate® Stacking Chair, and Hand Sanitizer Station.

VERSÉ®

Create more personal space in open areas with the Versé panel system. Easily connected and endlessly reconfigurable, Versé panels can maintain sightlines or maximize privacy, and keep frequently used items conveniently within reach. It's the smart long-term investment to support short-term work environments that are constantly changing.



FEATURES

- A variety of Versé panel widths and heights easily connect to one another to form workstations or offer privacy as space dividers. Available in sizes ranging from 24"-72"W and 42"-72"H.
- Steel hanging shelf hangs off the top of a Versé panel.
- Choose from three paint options to customize your office space.

VERSÉ® Panel System

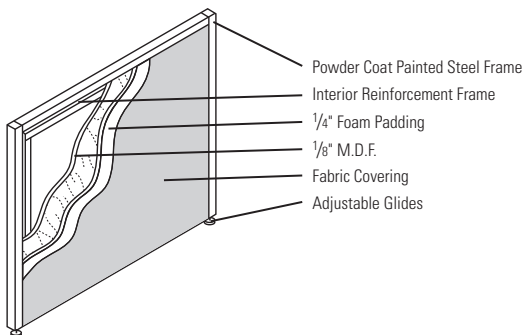
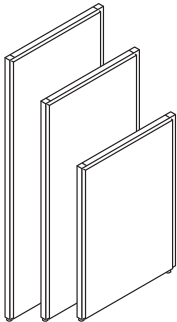
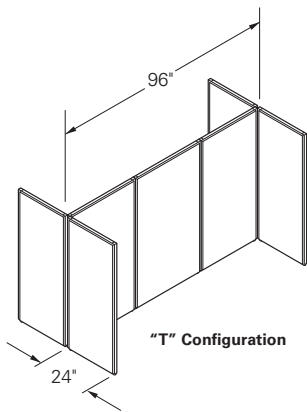
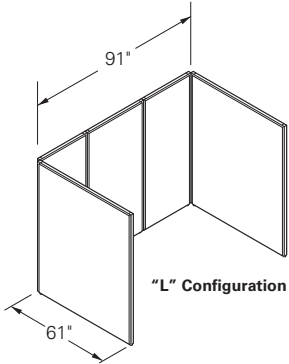

FEATURES

Panels

- Use Versé as a privacy panel (stand-alone) to create space division.

QuickConnect

(See page 623 for more details on this hardware.)

- Our QuickConnect connectors allow for easy installation. Simply snap on the connectors at the top and bottom of the panel and slide the panels together. There are only two connectors to specify for almost all configurations.

Storage

- Shelving capabilities. Each shelf width must match width of panel.

PANEL DIMENSIONS AND GROWTH ALLOWANCES

- All panel runs must be supported at each end of the panel run and supported at least every 8' within the panel run (maximum of 8' between supports).
- Support can be in the form of an adjustable wall bracket or return panel at 90° to the run.
- When using an "L" configuration, the return panel must measure at least 60% (minimum 36") of the unsupported run.
- When using a "T" configuration, each return panel must measure at least 20% of the unsupported run.
- Return panels can be no more than 24" lower than the panel height in the unsupported run.
- When used in conjunction with hanging shelves, panel width must match width of shelf.

VERSÉ PANELS

Includes

- Adjustable glides with all panels.

What Do I Need?

- QuickConnect Connectors.

Special Notes

- Versé panels feature a soft, padded look.
- Panels packed two per carton when possible.

Connection Type	Connectors Needed
Straight	1 pair – 180°
2-way (L)	1 pair – 90°
3-way (T)	2 pair – 90°
4-way (X)	3 pair – 90°

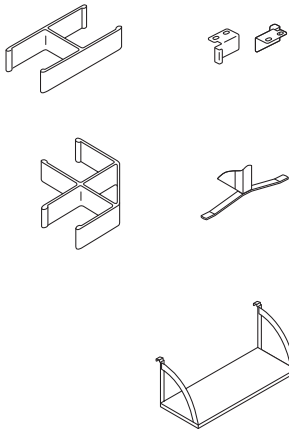

CONNECTING HARDWARE

Versé QuickConnect User Instructions

- Versé QuickConnect is easy to install. Simply snap on the connectors at the top and bottom of the panel and slide the panels together. There are only two connectors to specify for almost all configurations, including multi-height connections.
- 180° Straight Connector – use when connecting two panels together for a straight connection or for multi-height straight connections.
- 90° Corner Connector – use for 2-way, 3-way and 4-way corner connections. Only one pair is needed per corner connection or for multi-height corner connections.

HARDWARE

Special Notes

- Connectors add to the overall dimensions of the panel installation.
- These connector dimensions are important when space planning and sizing your panel layout.
- All hardware items may ship by a parcel service.
- Use HBV-PBS bracket with freestanding furniture for optimal workstation rigidity.

SHELVES

- Steel shelves are 14½" high.
- End brackets included.
- Must match panel width.
- Easy assembly; no tools required.

PANEL FABRIC & PAINT ORDERING CODES

PRICE CODE A	
CENTURION*	CU
◆ Apricot	CU47
◆ Bark	CU25
◆ Black	CU10
◆ Espresso	CU49
◆ Fog	CU03
◆ Frost	CU22
◆ Goldenrod	CU27
◆ Indigo	CU06
◆ Iris	CU50
◆ Iron Ore	CU19
◆ Jade	CU83
◆ Marsala	CU63
◆ Morel	CU24
◆ Navy	CU98
◆ Peacock	CU97
◆ Pear	CU84
◆ Ruby	CU67
◆ Sapphire	CU09

PRICE CODE A <i>continued</i>	
CONTOURETT POLYURETHANE*	VUR
◆ Baltic	VUR94
◆ Beach	VUR23
◆ Black	VUR10
◆ Bordeaux	VUR63
◆ Buff	VUR22
◆ Cloud	VUR18
◆ Coffee Bean	VUR49
◆ Crater	VUR51
◆ Flame	VUR62
◆ Graphite	VUR19
◆ Iron	VUR20
◆ Luggage	VUR26
◆ Marine	VUR92
◆ Navy	VUR95
◆ Nimbus	VUR93
◆ Ocean	VUR96
◆ Pumpkin	VUR42

PRICE CODE A <i>continued</i>	
CONTOURETT POLYURETHANE*	VUR
◆ Quarry	VUR24
◆ Red	VUR64
◆ Safari	VUR27
◆ Sage	VUR82
◆ Steel	VUR21
◆ Storm	VUR17
◆ Taupe	VUR28
◆ Trunk	VUR50

PRICE CODE A <i>continued</i>	
SEAWAY	2310
◆ Grey	2310GRE

PAINTS ORDERING CODES (Panel, T-base, Shelf and Connectors)	
Black	P
Light Gray	Q
Putty	L

* Centurion and Contourett fabrics are only able to exceed 54" in one direction (vertically or horizontally), not both directions.

! To clean Versé Panels with Contourett use a 1:5 diluted bleach and water mixture or Virex II 256. Leave cleaning solution on for at least 30 seconds but no longer than two minutes. Thoroughly remove the solution from the surface with a clean cloth and warm water. May cause discoloration if left on the surface longer than the suggested time or not removed after sanitizing.

◆◆◆ For lead time information see page 19.

VERSÉ® Panel System

OPEN MARKET

WORKSTATIONS

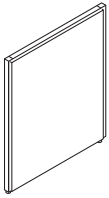

DESCRIPTION

42" H Panel

42" H x 24" W
42" H x 30" W
42" H x 36" W
42" H x 42" W
42" H x 48" W
42" H x 60" W
42" H x 72" W

NOTES: All panels include adjustable glides.

MODEL

HBV-P4224
HBV-P4230
HBV-P4236
HBV-P4242
HBV-P4248
HBV-P4260
HBV-P4272

SHIP WEIGHT

18
22
24
33
34
36
48

CUBE

1.8
2.2
2.7
3.1
3.6
4.4
5.3

LIST PRICE

\$307
\$318
\$322
\$324
\$339
\$365
\$419

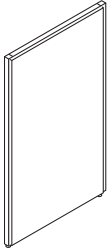

60" H Panel

60" H x 24" W
60" H x 30" W
60" H x 36" W
60" H x 42" W
60" H x 48" W
60" H x 60" W
60" H x 72" W

NOTES: All panels include adjustable glides.

HBV-P6024 ☉
HBV-P6030 ☉
HBV-P6036 ☉
HBV-P6042 ☉
HBV-P6048 ☉
HBV-P6060
HBV-P6072

30
33
35
37
42
54
60

2.5
3.2
3.8
4.4
5.0
6.4
7.5

\$341
\$353
\$354
\$371
\$377
\$394
\$461

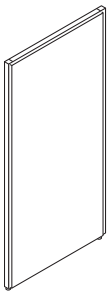

72" H Panel

72" H x 24" W
72" H x 30" W
72" H x 36" W
72" H x 42" W
72" H x 48" W
72" H x 60" W

NOTES: All panels include adjustable glides.

HBV-P7224 ☉
HBV-P7230 ☉
HBV-P7236 ☉
HBV-P7242 ☉
HBV-P7248 ☉
HBV-P7260

39
40
44
46
50
62

3.0
3.8
4.5
5.2
6.0
7.5

\$384
\$392
\$411
\$430
\$440
\$487

NOTES:

- **HON 5-Year Limited Warranty.**
- Panels offer privacy as room dividers or in desk-wrap applications.
- Panels feature 1" powder coat painted steel frame construction with interior reinforcement, 1/4" foam padding and 1/8" M.D.F.
- All panels include adjustable glides.
- To free-stand a single Versé panel or to stabilize the end of a panel run, order T-base stabilizing foot shown on page 623.
- See page 621 for available fabrics and finishes.

HOW TO SPECIFY

Select
Model Number

Select
Upholstery

See page 621

Select
Trim Color

P Black
Q Light Gray
L Putty





See page 621

HBV - P4224 .

2310GRE .

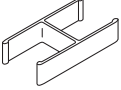
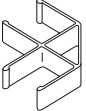
P

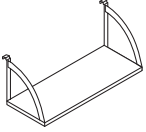

	DESCRIPTION	MODEL	SHIP WEIGHT	CUBE	LIST PRICE
	180° QuickConnect Straight Panel Connector Pair NOTES: 180° connector to be used to connect two panels in a straight connection or for multi-height straight connections.	HBV-QC180	0.1	0.3	\$24
	90° QuickConnect Panel Connector Pair NOTES: 90° connector to be used for 2-way, 3-way or 4-way corner connections, or for multi-height connections.	HBV-QC90	0.1	0.3	\$24
	Wall Bracket	HBV-PWB1	0.2	0.3	\$52
	Panel-to-Worksurface Bracket Pair	HBV-PBS	0.3	0.3	\$44
	T-Base Stabilizing Foot 18 ³ / ₄ " long NOTES: Adds 1 ¹ / ₄ " to the height of the panel.	HBV-TBASE	6.0	0.3	\$48
	Hanging Shelves 24"W x 12 ³ / ₄ "D 30"W x 12 ³ / ₄ "D 36"W x 12 ³ / ₄ "D 42"W x 12 ³ / ₄ "D 48"W x 12 ³ / ₄ "D 60"W x 12 ³ / ₄ "D NOTES: Shelves hang over the top of panels. Supporting panel must match the width of the shelf.	HBV-VSH24 ☉ HBV-VSH30 ☉ HBV-VSH36 ☉ HBV-VSH42 ☉ HBV-VSH48 ☉ HBV-VSH60 ☉	9.0 10.0 12.0 13.0 14.0 19.0	1.2 1.5 1.8 2.0 2.3 2.9	\$195 \$217 \$237 \$256 \$292 \$333

NOTES:

- **HON 5-Year Limited Warranty.**
- T-base stabilizing foot optional.
- Extruded aluminum connectors are sold in pairs and are used at top and bottom of panels.
- Shelves hang over the top of panels; the supporting panel must match the width of the shelf.
- Shelves feature steel construction with powder coat paint finish.
- Shelves ship easy to assemble – no tools required.
- See page 621 for available fabrics and finishes.

HOW TO SPECIFY

<p>Select Model Number</p> <p>HBV - QC180</p>	<p>Select Trim Color</p> <p>See page 621</p> <p>P</p>
---	---

OVERVIEW OF PERSONAL STORAGE AND PEDESTALS

LATERAL FILES

Advantages:

a) The most efficient means of conventional filing; b) Ideal for active filing in workstations, where higher volume capacity is necessary and retrieval is frequent

Considerations:

2-drawer steel lateral files fit under standard-height worksurfaces when using panel systems.

VERTICAL FILES

Advantages:

a) Economical; b) The most widely used filing method; c) requires minimal floor space

Considerations:

Vertical files are best suited for long-term storage, where retrieval is less frequent. For larger banks of files, lateral files are more space-efficient than vertical files.

BOOKCASES

Advantages:

a) These units are ideal for binders, reference books or other items; b) Available with your choice of fixed or movable shelves

Considerations:

If working with panel systems, it is more attractive to specify units that are lower than the panel height.

FILING TECHNIQUES

Type	Standing Files	Hanging Files
Advantages	Inexpensive. Uses existing file folders.	Easier organization and identification of the file folders. Files viewed from top. Remaining files hold their place when folders are removed. Easier to re-stock.
Requirements	Follower block or Dividers	Hangrails or high-drawer sides
Can be used in	<ul style="list-style-type: none"> Vertical files (front-to-back only) Lateral files (side-to-side only in drawers) Shelf files (side-to-side only) 	<ul style="list-style-type: none"> Vertical files (front-to-back only) Lateral files (front-to-back or side-to-side in drawers)

Contain[®]/Flagship[®]/Brigade[®] Series Pedestals Utilization with 38000 Series and 66000 Series.

Pedestal Depths	Abound [®] and Accelerate [®] Panel-Hung Worksurfaces			66000 StationMaster		38000 Series Modular Desks		
	18" Deep	24" Deep	30" Deep	24" Deep	29½" Deep	24" Deep	30" Deep	36" Deep
16¾" Deep	•	•	•	•	•	•	•	•
22⅞" Deep		•	•		•	•*	•	•
28⅞" Deep			•				•	•

* Cannot attach 22⅞" D Hanging Pedestal.

WORKING WITH STORAGE PEDESTALS

Storage Pedestals are available in 5 styles:

- Box/File Mobile.....(Model Nos. beginning with HSPM)
- Freestanding(Model Nos. beginning with HSPF)
- Hanging(Model Nos. beginning with HSPH)
- Worksurface Supporting**(Model Nos. beginning with HSPS)
- Under Worksurface Mobile.....(Model Nos. beginning with HSPM)

Worksurface height supporting pedestals have a taller base plate, resulting in a taller overall cabinet height. Consideration must be made to ensure that units align visually with each other. The accompanying chart will help you select the correct pedestal for your application.

Pedestal Models (Nos. begin with)	Style	Overall Height	Base Height	Spacer Required Below Worksurface
HSPM or H15	Box/File mobile	22⅝"	N/A	N/A
HSPF	Freestanding	28"	3½"	NO
HSPH or H14	Hanging	19½"	N/A	N/A
HSPS or H19 or H36	Worksurface supporting**	28"	3⅞"	NO
HSPM or H18 or H33	Under Worksurface mobile	28"	3⅞"	NO

** Units will support conventional 29½" H worksurfaces, WITHOUT SPACERS.

LATERAL FILING OPTIONS

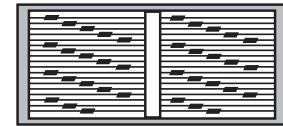

Front-to-back filing:

30" wide files: 30½" of filing with letter/letter rows.

36" wide files: 30½" of filing with letter/letter, legal/legal, or letter/legal rows.

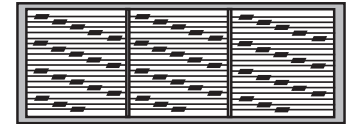

42" wide files: 45¼" of filing with 3 rows letter or 30½" of 2 rows legal, or 2 standard printout rows.

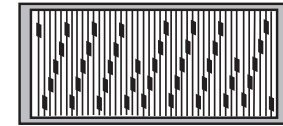

Side-to-side filing:

30" wide files: 27" of filing with letter or legal.

36" wide files: 33" of filing with letter or legal.

42" wide files: 39" of filing with letter or legal.

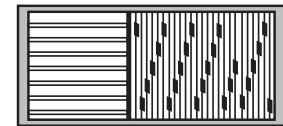

Combination filing:

(front-to-back with side-to-side in one drawer)

30" wide files: not recommended.

36" wide files: 15¼" of front-to-back filing and 20¼" of side-to-side legal filing.

42" wide files: 15¼" of front-to-back filing and 26¼" of side-to-side legal filing.

* Requires H919491 optional hangrails.

** Requires H919492 optional hangrails.

HON LATERAL FILES AT A GLANCE

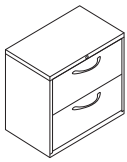

Flagship®

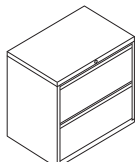

**Brigade®
Model H872L**

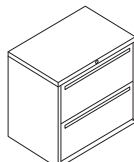

**Brigade®
Model H772L**

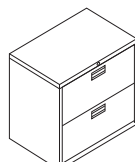

**Brigade®
Model H672L**



400 Series

Flagship Series lateral files are 18"D.

Brigade® 800, 700, 600 and 500 Series lateral files are all 18"D.

Series	Widths Available	Heights Available	Suspension Style	Usage	Pull	Safety Interlock	Lock	Features
Flagship, Brigade® 800, 700, 600	30" 36" 42"	2 dwr 3 dwr 4 dwr 5 dwr	Heavy-Duty ball-bearing (telescoping)	Intensive	<p>Flagship Series 3 Pulls available. See page 627.</p> <p>Brigade® 800 Series Full-width radius designer style with magnetic label holders</p> <p>Brigade® 700 Series Full-width designer style with magnetic label holders</p> <p>Brigade® 600 Series Anodized Aluminum with label magnetic holder</p>	Positive Mechanical	Core removable	<ul style="list-style-type: none"> • 4 leveling glides • 2 hangrails per drawer • Rack resistant case reinforcement • Flagship® and Brigade® can be used with Storage Islands
400	30" 36"	2 dwr 4 dwr	Ball-bearing	Moderate	Color-matched polymer Monochromatic drawer pulls	Positive Mechanical	Core removable	<ul style="list-style-type: none"> • 2 leveling glides

All products meet or exceed ANSI/BIFMA and ISTA performance standards.

HON VERTICAL FILES AT A GLANCE

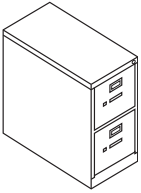

Model H212

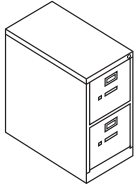

Model H312



Model H512

Vertical files listed below meet or exceed ANSI/BIFMA and ISTA performance standards. They are available in 15"W letter and 18¼"W legal widths.

STORAGE

Series	Depth	Heights Available	Suspension Style	Lock	Accepts Hanging Files	Features
210 Series	28½"	2 dwr 4 dwr 5 dwr	Three-part telescoping, ball-bearing steel suspension	INCLUDED core removable	YES (Hangrails not required)	Spring-loaded follower block
310 Series	26½"	2 dwr 4 dwr 5 dwr	Three-part telescoping, ball-bearing steel suspension	INCLUDED core removable	YES (Hangrails not required)	Spring-loaded follower block
510 Series	25"	2 dwr 4 dwr	Three-part telescoping, ball-bearing steel suspension	INCLUDED core removable	YES (Hangrails not required)	Adjustable wire follower

STORAGE AND FILES ORDERING INFORMATION

CONTAIN® PRODUCT

L1 LAMINATES CODES

Woodgrain

- ◆ Bourbon Cherry H
- ◆ Cognac COGN
- ◆ Florence Walnut LFW1
- ◆ Harvest C
- ◆ Kingswood Walnut LK11
- ◆ Mahogany N
- ◆ Mocha MOCH
- ◆ Natural Maple D
- ◆ Pinnacle PINC
- ◆ Shaker Cherry F
- ◆ Sterling Ash LSA1

L2 LAMINATES CODES

Woodgrain

- ◆ Lowell Ash LLA1
- ◆ Natural Recon LNR1
- ◆ Phantom Ecru LPE1
- ◆ Portico Teak LPT1
- ◆ Skyline Walnut LSW1

OPTIONAL LAMINATE TOPS FOR LATERAL FILES AND CONTAIN® CREDENZAS

L1 LAMINATES CODES

Woodgrain

- ◆ Bourbon Cherry H
- ◆ Cognac COGN
- ◆ Florence Walnut LFW1
- ◆ Harvest C
- ◆ Kingswood Walnut LK11
- ◆ Mahogany N
- ◆ Mocha MOCH
- ◆ Natural Maple D
- ◆ Pinnacle PINC
- ◆ Shaker Cherry F
- ◆ Sterling Ash LSA1

Solid

- ◆ Charcoal S
- ◆ Designer White LDW1
- ◆ Loft LOFT

Patterned

- ◆ Sheer Mesh* A5
- ◆ Silver Mesh* B9
- ◆ Steel Mesh* A9
- ◆ Canyon Zephyr K9
- ◆ Desert Zephyr K8
- ◆ Shadow Zephyr K1
- ◆ Gray* G2
- ◆ White* G1

L2 LAMINATES CODES

Woodgrain

- ◆ Lowell Ash LLA1
- ◆ Natural Recon LNR1
- ◆ Phantom Ecru LPE1
- ◆ Portico Teak LPT1
- ◆ Skyline Walnut LSW1

OPTIONAL LAMINATE TOPS FOR STEEL BOOKCASES

L1 LAMINATES CODES

Woodgrain

- ◆ Bourbon Cherry H
- ◆ Florence Walnut LFW1
- ◆ Harvest C
- ◆ Kingswood Walnut LK11
- ◆ Mahogany N
- ◆ Natural Maple D
- ◆ Shaker Cherry F
- ◆ Sterling Ash LSA1

Solid

- ◆ Charcoal S
- ◆ Designer White LDW1

Patterned

- ◆ Sheer Mesh* A5
- ◆ Silver Mesh* B9
- ◆ Steel Mesh* A9
- ◆ Canyon Zephyr K9
- ◆ Desert Zephyr K8
- ◆ Shadow Zephyr K1
- ◆ Gray* G2
- ◆ White* G1

1870 SERIES BOOKCASES

L1 LAMINATES CODES

Woodgrain

- ◆ Cognac COGN
- ◆ Harvest C
- ◆ Mahogany N

FLAGSHIP®, CONTAIN® PRODUCT, BRIGADE PEDESTALS, BRIGADE 800, 700, 600 LATERAL FILES, 210, 310/H320, AND 510 SERIES VERTICAL FILES, BRIGADE STORAGE CABINETS, BRIGADE STEEL BOOKCASES

PAINTS CODES

P1

- ◆ Black P
- ◆ Brownstone P7D
- ◆ Charcoal S
- ◆ Designer White PJW
- ◆ Fossil P28
- ◆ Greige T5
- ◆ Light Gray Q
- ◆ Loft LOFT
- ◆ Muslin T3
- ◆ Putty L
- ◆ Shadow* SHDW
- ◆ Titanium P8T

P2

- ◆ Champagne Metallic T4
- ◆ Platinum Metallic T1
- ◆ Silver** PR6
- ◆ Solar Black** P8X

400 SERIES LATERAL, FLAMESAFE FILES

PAINTS CODES

P1

- ◆ Black P
- ◆ Light Gray Q
- ◆ Loft LOFT
- ◆ Putty L

PULL OPTIONS FOR CONTAIN® AND FLAGSHIP® STORAGE

Suffix "A"



Satin Chrome Arch Pull

Suffix "N"



Full Face Integral Drawer Pull

Suffix "R"



Full Radius Drawer Pull

NOTES: Arch pulls available in Satin Chrome only.

* Laminate colors will have the following pre-set edgeband colors:

** Only available on Flagship® Pedestals and Contain®.

Laminate	Edge
Sheer Mesh	Muslin
Silver Mesh	Loft
Steel Mesh	Charcoal
Gray	Charcoal
White	Charcoal

Edgeband matches top except as noted.

For Champagne Metallic Paint, Muslin is the suggested edgeband color. When Champagne Metallic Paint is selected, pulls are standard in Muslin.

- The HON Company has elected to discontinue the HON Choice paint program, as of 12/31/2018, and roll it into our standard specials process.
- A special request will need to be submitted to receive pricing and order information.

◆◆◆ For lead time information see page 19.

* De-emphasized

BRIGADE®

STORAGE



Brigade® Storage.

BRIGADE®

You don't need an army to bring order to your office. Just a brigade. Sturdily built to rigorous specifications, our Brigade storage is ready to serve any organization needing top-quality storage. With welded construction and features like heavy-duty steel ball-bearing suspensions, it outlasts and outperforms most build-it-yourself options. Brigade was built to soldier on.



FEATURES

- Clean, straightforward design complements and blends in with any workspace.
- Optional Storage Islands laminate tops provide extra surface area for technology tools, collating or stand-up work.
- With a combination of reasonable pricing and high quality, Brigade is a value that's hard to beat.
- Heavy-duty Steel ball-bearing drawer suspensions operate easily and quietly.
- Mechanical interlock prevents more than one drawer from being opened at a time, for stability.

BRIGADE® ORDERING INFORMATION

BRIGADE PRODUCTS

PAINTS CODES

P1

◆ Black	P
◆ Brownstone	P7D
◆ Charcoal	S
◆ Designer White	PJW
◆ Fossil	P28
◆ Greige	T5
◆ Light Gray	Q
◆ Loft	LOFT
◆ Muslin	T3
◆ Putty	L
◆ Shadow *	SHDW
◆ Titanium	P8T

P2

◆ Champagne Metallic	T4
◆ Platinum Metallic	T1

OPTIONAL LAMINATE TOPS FOR LATERAL FILES AND CONTAIN® CREDENZAS

L1 LAMINATES CODES

Woodgrain

◆ Bourbon Cherry	H
◆ Cognac	COGN
◆ Florence Walnut	LFW1
◆ Harvest	C
◆ Kingswood Walnut	LK11
◆ Mahogany	N
◆ Mocha	MOCH
◆ Natural Maple	D
◆ Pinnacle	PINC
◆ Shaker Cherry	F
◆ Sterling Ash	LSA1

Solid

◆ Charcoal	S
◆ Designer White	LDW1
◆ Loft	LOFT

Patterned

◆ Sheer Mesh*	A5
◆ Silver Mesh*	B9
◆ Steel Mesh*	A9
◆ Canyon Zephyr	K9
◆ Desert Zephyr	K8
◆ Shadow Zephyr	K1
◆ Gray*	G2
◆ White*	G1

L2 LAMINATES CODES

Woodgrain

◆ Lowell Ash	LLA1
◆ Natural Recon	LNRI
◆ Phantom Ecu	LPE1
◆ Portico Teak	LPT1
◆ Skyline Walnut	LSW1

For Champagne Metallic Paint, Muslin is the suggested edgeband color.

- The HON Company has elected to discontinue the HON Choice paint program, as of 12/31/2018, and roll it into our standard specials process.
- A special request will need to be submitted to receive pricing and order information.

* Laminate colors will have the following pre-set edgeband colors:

Laminate	Edge
Sheer Mesh	Muslin
Silver Mesh	Loft
Steel Mesh	Charcoal
Gray	Charcoal
White	Charcoal

Edgeband matches top except as noted.

◆◆◆ For lead time information see page 19.

* De-emphasized





BRIGADE® Standard Height Pedestals

GSA SIN 33721

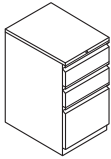

Icon Legend on page 19

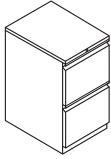
STORAGE

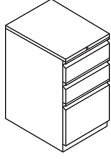
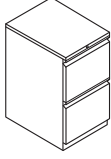
	DESCRIPTION	MODEL	SHIP WEIGHT	CUBE	LIST PRICE BY PAINT GRADE		
					P1	P2	P3
	Standard Height Mobile Pedestals — Box/Box/File						
	15"W x 19 ⁷ / ₈ "D x 28"H	H33720(?)	73	6.6	\$611	\$639	\$667
	15"W x 22 ⁷ / ₈ "D x 28"H	H33723(?) 	77	7.5	\$630	\$658	\$686
	Standard Height Mobile Pedestals — File/File						
	15"W x 19 ⁷ / ₈ "D x 28"H	H33820(?)	73	6.6	\$605	\$633	\$661
	15"W x 22 ⁷ / ₈ "D x 28"H	H33823(?) 	77	7.5	\$624	\$652	\$680
	Standard Height Freestanding Support Pedestals — Box/Box/File						
	15"W x 19 ⁷ / ₈ "D x 28"H	H36720(?)	61	6.6	\$600	\$628	\$656
	15"W x 22 ⁷ / ₈ "D x 28"H	H36723(?)	83	7.5	\$622	\$650	\$678
	Standard Height Freestanding Support Pedestals — File/File						
	15"W x 19 ⁷ / ₈ "D x 28"H	H36820(?)	61	6.6	\$595	\$623	\$651
	15"W x 22 ⁷ / ₈ "D x 28"H	H36823(?)	83	7.5	\$616	\$644	\$672

NOTES:

- 28"H fits under all HON worksurfaces and desk shells.
 - Pencil tray standard in top box drawer.
 - One box divider standard in each box drawer.
 - One crossrail standard in each file drawer.
 - Ball-bearing suspension on file and box drawers with 90% extension.
 - File drawers have high sides for filing front-to-back.
 - See pages 723-724 for accessories and pedestal utilization information.
 - Equipped with HON "One Key" interchangeable core removable locks.
 - Front casters are fixed, rear casters swivel on mobile pedestals.
 - "N" Pull matches Brigade 700 Series lateral file pull.
 - "R" pull matches Brigade 800 Series Lateral Pull.
 - See pages 723-724 for Pedestal Accessories. Additional Flagship pedestal models on pages 680-681.
-  Freestanding support pedestals that are not positioned and attached under a worksurface, require a counterweight kit found on page 723.

HOW TO SPECIFY

<p>Select Model Number</p> <p>Select the Pull</p> <p>N Full Face Integral R Full Radius</p> <p>H 3 3 7 2 0 R</p>	<p>Select Lock Option</p> <p>L Lock</p> <p>L</p>	<p>Select Paint Color</p> <p>See page 629</p> <p>P</p>
---	--	--



Icon Legend on page 19

BRIGADE® 800 SERIES

Lateral Files w/Drawers

	DESCRIPTION	MODEL	SHIP WEIGHT	CUBE	LIST PRICE BY PAINT GRADE		
					P1	P2	P3
	Lateral File — 2 Drawer						
	30"W x 18"D x 28"H	H872	121	12.2	\$807	\$840	\$874
	36"W x 18"D x 28"H	H882	131	14.3	\$902	\$935	\$969
	42"W x 18"D x 28"H	H892	141	16.7	\$1043	\$1076	\$1110
	Lateral File — 3 Drawer						
	30"W x 18"D x 39½"H	H873	158	16.4	\$1147	\$1180	\$1214
	36"W x 18"D x 39½"H	H883	175	19.1	\$1279	\$1312	\$1346
	42"W x 18"D x 39½"H	H893	190	22.4	\$1483	\$1516	\$1550
	Lateral File — 4 Drawer						
	30"W x 18"D x 52½"H	H874	197	21.4	\$1390	\$1457	\$1523
	36"W x 18"D x 52½"H	H884	217	25.1	\$1576	\$1643	\$1709
	42"W x 18"D x 52½"H	H894	232	29.4	\$1809	\$1876	\$1942
	Lateral File — 5 Drawer						
	30"W x 18"D x 64¼"H	H875	199	25.8	\$1846	\$1913	\$1979
	36"W x 18"D x 64¼"H	H885	215	30.1	\$2078	\$2145	\$2211
	42"W x 18"D x 64¼"H	H895	244	35.3	\$2400	\$2467	\$2533

STORAGE

NOTES:

- 30", 36" & 42" case widths with drawers, 18" case depth.
- Flush top and sides.
- Reinforced case construction.
- Four adjustable leveling glides.
- Full-width radius designer style pull.
- Features drawer extension restraint; mechanical interlock inhibits the extension of more than one drawer at a time.
- Three-part, telescoping, steel ball-bearing suspension.
- Two adjustable hangrails per drawer for side-to-side filing.
- Counterweight included where applicable to meet ANSI/BIFMA stability requirements.
- Lock mechanism secures both sides of drawer.
- Baked enamel finish over rust-inhibiting phosphate pre-treatment.
- Equipped with HON "One Key" interchangeable core removable locks.
- Optional laminate tops and accessories — see page 720.
- See page 720 for Lateral File Accessories.

Keyed alike cores must be ordered separately — see page 746.

HOW TO SPECIFY

Select Model Number 	Select Lock Option L Lock 	Select Paint Color See page 629
--------------------------------	---	---

BRIGADE® 800 SERIES Lateral Files w/Storage

GSA SIN 33721



Icon Legend on page 19

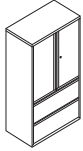

DESCRIPTION

Lateral File w/Storage — 2 Drawer

30"W x 18"D x 64¼"H

36"W x 18"D x 64¼"H

42"W x 18"D x 64¼"H

MODEL	SHIP WEIGHT	CUBE	LIST PRICE BY PAINT GRADE		
			P1	P2	P3
H875LS	174	27.5	\$1482	\$1549	\$1615
H885LS	210	32.9	\$1633	\$1700	\$1766
H895LS	228	38.0	\$1866	\$1933	\$1999

NOTES:

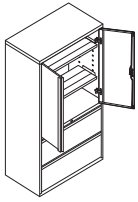

- 30", 36" & 42" case widths, 18" case depth.
- 46¼"H case - matches height of 800 Series 5 Drawer laterals.
- Bottom two openings are lateral drawers, remainder of case is storage shelves.
- Lateral file drawer features are same as 800 Series Laterals shown on previous page.
- Inside dimension of storage case is 36¼"H. Includes 2 adjustable shelves, adjustable in 2" increments. Bottom shelves accept two rows of 3-ring binders; top opening measures: 10¼".
- Storage case is standard with 2 hinged doors. Door pulls match lateral file drawer pulls.
- Equipped with HON "One Key" interchangeable core removable locks. Locks on storage case and lateral file are keyed alike. Lateral file drawers lock independently from storage case.
- Four adjustable leveling glides.
- See page 720 for Lateral File Accessories and page 636 for Wire Dividers.

STORAGE

HOW TO SPECIFY

Select Model Number

H 8 7 5 L S .

Select Lock Option

L Lock

L .

Select Paint Color

See page 629

T 1



BRIGADE® 700 SERIES

Lateral Files w/Drawers

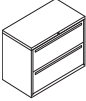
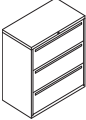
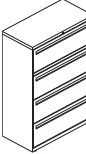
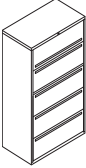
	DESCRIPTION	MODEL	SHIP WEIGHT	CUBE	LIST PRICE BY PAINT GRADE		
					P1	P2	P3
	Lateral File — 2 Drawer (locking)						
	30"W x 18"D x 28"H	H772	121	12.2	\$807	\$840	\$874
	36"W x 18"D x 28"H	H782	131	14.3	\$902	\$935	\$969
	42"W x 18"D x 28"H	H792	141	16.7	\$1043	\$1076	\$1110
	Lateral File — 3 Drawer (locking)						
	30"W x 18"D x 39 ¹ / ₈ "H	H773	158	16.4	\$1147	\$1180	\$1214
	36"W x 18"D x 39 ¹ / ₈ "H	H783	175	19.1	\$1279	\$1346	\$1412
	42"W x 18"D x 39 ¹ / ₈ "H	H793	190	22.4	\$1483	\$1516	\$1550
	Lateral File — 4 Drawer (locking)						
	30"W x 18"D x 52 ¹ / ₂ "H	H774	197	21.4	\$1390	\$1457	\$1523
	36"W x 18"D x 52 ¹ / ₂ "H	H784	217	25.1	\$1576	\$1643	\$1709
	42"W x 18"D x 52 ¹ / ₂ "H	H794	232	29.4	\$1809	\$1876	\$1942
	Lateral File — 5 Drawer (locking)						
	30"W x 18"D x 64 ¹ / ₄ "H	H775	199	25.8	\$1846	\$1913	\$1979
	36"W x 18"D x 64 ¹ / ₄ "H	H785	215	30.1	\$2078	\$2145	\$2211
	42"W x 18"D x 64 ¹ / ₄ "H	H795	244	35.3	\$2400	\$2467	\$2533



NOTES: Top drawer is a roll-out shelf.

NOTES:

- 30", 36" & 42" case widths with drawers, 18" case depth.
- Flush top and sides.
- Reinforced case construction.
- Four adjustable leveling glides.
- Full-face integral drawer pulls.
- Features drawer extension restraint; mechanical interlock inhibits the extension of more than one drawer at a time.
- Three-part, telescoping, steel ball-bearing suspension.
- Two adjustable hangrails per drawer/rollout shelf for side-to-side filing.
- Counterweight included where applicable to meet ANSI/BIFMA stability requirements.
- Lock mechanism secures both sides of drawer.
- Baked enamel finish over rust-inhibiting phosphate pre-treatment.
- Optional laminate tops and accessories — see page 720.
- Equipped with HON "One Key" interchangeable core removable locks.
- See page 720 for Lateral File Accessories.

! Keyed alike cores must be ordered separately — see page 746.

HOW TO SPECIFY

Select Model Number 	Select Lock Option L Lock 	Select Paint Color See page 629 
---	--	--

BRIGADE® 700 SERIES

Lateral Files w/Storage

GSA SIN 33721



Icon Legend on page 19

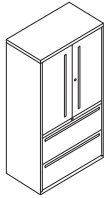

DESCRIPTION

Lateral File w/Storage — 2 Drawer

30"W x 18"D x 64¼"H

36"W x 18"D x 64¼"H

42"W x 18"D x 64¼"H

MODEL	SHIP WEIGHT	CUBE	LIST PRICE BY PAINT GRADE		
			P1	P2	P3
H775LS	175	27.5	\$1482	\$1549	\$1615
H785LS	211	32.9	\$1633	\$1700	\$1766
H795LS	230	38.0	\$1866	\$1933	\$1999

NOTES:

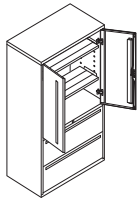

- 30", 36" & 42" case widths, 18" case depth.
- 64¼"H case - matches height of 700 Series 5 Drawer laterals.
- Bottom two openings are lateral drawers, remainder of case is storage shelves.
- Lateral file drawer features are same as 700 Series Laterals shown on previous page.
- Inside dimension of storage case is 36¼"H. Includes 2 adjustable shelves, adjustable in 2" increments. Bottom shelves accept two rows of 3-ring binders; top opening measures: 10¼".
- Storage case is standard with 2 hinged doors. Door pulls match lateral file drawer pulls.
- Equipped with HON "One Key" interchangeable core removable locks. Locks on storage case and lateral file are keyed alike. Lateral file drawers lock independently from storage case.
- Four adjustable leveling glides.
- See page 720 for Lateral File Accessories and page 636 for Wire Dividers.

STORAGE

HOW TO SPECIFY

Select Model Number

H 7 7 5 L S .

Select Lock Option

L Lock

L .

Select Paint Color

See page 629









T 1



Icon Legend on page 19

BRIGADE® 600 SERIES

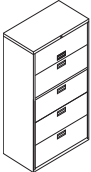
Lateral Files w/Drawers

	DESCRIPTION	MODEL	SHIP WEIGHT	CUBE	LIST PRICE BY PAINT GRADE		
					P1	P2	P3
	Lateral File — 2 Drawer						
	30"W x 18"D x 28"H	H672	121	12.2	\$745	\$812	\$878
	36"W x 18"D x 28"H	H682 	131	14.3	\$801	\$834	\$868
	42"W x 18"D x 28"H	H692	141	16.7	\$945	\$978	\$1012
	Lateral File — 3 Drawer						
	30"W x 18"D x 39 ¹ / ₈ "H	H673	158	16.4	\$1023	\$1090	\$1156
	36"W x 18"D x 39 ¹ / ₈ "H	H683 	175	19.1	\$1119	\$1152	\$1186
	42"W x 18"D x 39 ¹ / ₈ "H	H693	190	22.4	\$1314	\$1347	\$1381
	Lateral File — 4 Drawer						
	30"W x 18"D x 52 ¹ / ₂ "H	H674	197	21.4	\$1270	\$1337	\$1403
	36"W x 18"D x 52 ¹ / ₂ "H	H684 	217	25.1	\$1389	\$1456	\$1522
	42"W x 18"D x 52 ¹ / ₂ "H	H694	232	29.4	\$1647	\$1714	\$1780
	Lateral File — 5 Drawer						
	30"W x 18"D x 64 ¹ / ₄ "H	H675	199	25.8	\$1688	\$1755	\$1821
	36"W x 18"D x 64 ¹ / ₄ "H	H685 	215	30.1	\$1804	\$1871	\$1937
	42"W x 18"D x 64 ¹ / ₄ "H	H695	244	35.3	\$2176	\$2243	\$2309



STORAGE

NOTES:

- 30", 36" & 42" case widths with drawers, 18" case depth.
- Flush top and sides.
- Reinforced case construction.
- Four adjustable leveling glides.
- Features drawer extension restraint; mechanical interlock inhibits the extension of more than one drawer at a time.
- Three-part, telescoping, steel ball-bearing suspension.
- Two adjustable hangrails per drawer/roll-out shelf for side-to-side filing.
- Counterweight included where applicable to meet ANSI/BIFMA stability requirements.
- Lock mechanism secures both sides of drawer.
- Baked enamel finish over rust-inhibiting phosphate pre-treatment.
- Bright anodized aluminum recessed drawer pull.
- Equipped with HON "One Key" interchangeable core removable locks.
- Optional laminate tops and accessories — see page 720.
- See page 720 for Lateral File Accessories.

 Keyed alike cores must be ordered separately — see page 746.

HOW TO SPECIFY

Select Model Number 	Select Lock Option L Lock 	Select Paint Color See page 629 
---	--	--

BRIGADE[®] Metal Dividers

GSA SIN 33721

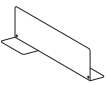
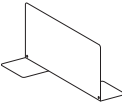

Icon Legend on page 19

	DESCRIPTION	MODEL	SHIP WEIGHT	CUBE	LIST PRICE P1
	Metal Box Divider				
	10 pack	HSCABD10	7	0.7	\$170
	2 pack	HSCABD02	2	0.7	\$43
! Metal dividers available in Black only. No need to specify.					
	Metal File Divider				
	10 pack	HSCAFD10	12	0.7	\$202
	2 pack	HSCAFD02	3	0.7	\$53
! Metal dividers available in Black only. No need to specify.					

STORAGE

HOW TO SPECIFY

Select
Model Number

H S C A B D 1 0



BRIGADE®

Steel Bookcases

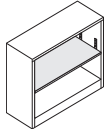

Shaded shelves
are adjustable.

DESCRIPTION

Steel Bookcase

34½"W x 12⅝"D x 29"H, 2-Shelf
 34½"W x 12⅝"D x 41"H, 3-Shelf
 34½"W x 12⅝"D x 59"H, 4-Shelf
 34½"W x 12⅝"D x 71"H, 5-Shelf
 34½"W x 12⅝"D x 81⅝"H, 6-Shelf

MODEL	SHIP WEIGHT	CUBE	LIST PRICE BY PAINT GRADE		
			P1	P2	P3
HS30ABC	44	9.6	\$262	\$295	\$329
HS42ABC	57	13.3	\$314	\$347	\$381
HS60ABC	77	18.9	\$468	\$535	\$601
HS72ABC	87	22.6	\$534	\$601	\$667
HS82ABC	97	27.5	\$772	\$839	\$905

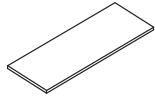

Extra Shelf for all Models

NOTES: Edge is ⅜" thick. Specify: Paint

HB9	7 Ⓞ	0.3	\$88	\$101	\$111
-----	-----	-----	------	-------	-------

NOTES:

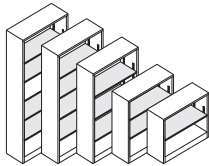

- Available in 2, 3, 4, 5, and 6 shelf models.
- Inside shelf depth is 12⅝".
- Bookcase shelves easily adjust in ½" increments (shaded shelves are adjustable).
- Optional laminate tops available.
- Baked enamel finish over rust-inhibiting phosphate pre-treatment.

HOW TO SPECIFY

Select Model Number

H S 3 0 A B C .

Select Paint Color

See page 629

P

DESCRIPTION	MODEL	SHIP WEIGHT	CUBE	LIST PRICE
 Laminate Top for all Models NOTES: Specify: Laminate	H511596	16 Ⓞ	0.7	\$265

HOW TO SPECIFY

Select Model Number

H 5 1 1 5 9 6 .

Select Laminate

See page 629

N

BRIGADE® Storage Cabinets

GSA SIN 33721



Icon Legend on page 19



71¾" High

DESCRIPTION

Storage Cabinets

36"W x 18½"D x 72"H
36"W x 24½"D x 72"H

NOTES: Includes 5 adjustable shelves.

MODEL	SHIP WEIGHT	CUBE	LIST PRICE BY PAINT GRADE		
			P1	P2	P3
HSC1872	131	36.5	\$1032	\$1099	\$1165
HSC2472	149	46.7	\$1294	\$1361	\$1427

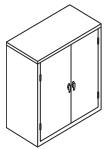

41¼" High

Storage Cabinet

36"W x 18½"D x 41¼"H

NOTES: Includes 2 adjustable shelves.

HSC1842	82	21.8	\$872	\$917	\$961
---------	----	------	-------	-------	-------

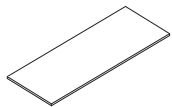

Additional Shelves

36"W x 18"D
36"W x 24"D

HAS18	6	0.6	\$122	\$135	\$145
HAS24	8	0.7	\$152	\$165	\$175

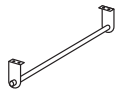

Conversion Kit

Hanging Bar and brackets to convert a Storage Cabinet into a Wardrobe Cabinet.

HWC72	5	0.4	\$113		
-------	---	-----	-------	--	--

NOTES: Necessary hardware included to screw into shelf.

❗ For use on 72"H HSC Model Storage Cabinets shown above, only.

❗ Aluminum finish only. No need to specify paint color.

SPECIFY: HWC72

NOTES:

- Product shipped fully assembled.
- All shelves are adjustable in 2" increments.
- Stretch-wrap cartoning.
- Flush top.
- Two adjustable leveling glides standard.
- Reinforced base.
- One locking handle, one fixed handle.
- Adjustable shelves.
- Doors have vertical stiffener standard.
- Positive door stops.
- Equipped with HON "One Key" interchangeable core removable locks.

❗ Keyed alike cores must be ordered separately – see page 746.

HOW TO SPECIFY

Select Model Number H S C 2 4 7 2 .	Select Lock Option L Lock	Select Paint Color See page 629 P
---	-------------------------------------	--



Contain® Lockers with Electronic Locks.

CONTAIN®

Harder-working storage. That's what you need. So we re-examined it from the inside out and developed our new Contain storage solutions. With a variety of shapes and sizes, functions and configurations, Contain can help you expand your capabilities for storage, efficiency, and collaboration — and elevate your aesthetic too.



FEATURES

- Contain® provides the storage solutions you need, where you need them. Personal workstations, private offices, shared spaces, Contain® has you covered.
- Combine metal and laminate to create a unique and unified look for your office.
- Add a pop of color with standard HON paint or Colorwav paint options.
- **Punch up the personality of your locker, wardrobe, or tower with dual paint options, available in traditional HON colors or vibrant Colorwav hues.**
- Choose between a footed base to create a stand-alone furniture aesthetic, a recessed kickplate that matches both the drawer fronts, or an optional flush kickplate.
- Pair low credenzas and pedestals with seat cushions to turn any space into a collaborative hub.
- Leave the key in the past with our digital keypad or RFID lock options.
- Incorporate Contain® lockers and wardrobes into Storage Islands to create simple touchdown spaces throughout the office.

CONTAIN® ORDERING INFORMATION

STORAGE

CONTAIN® PRODUCTS CASE PAINT

PAINTS	CODES
P1	
◆ Black	P
◆ Brownstone	P7D
◆ Charcoal	S
◆ Designer White	PJW
◆ Fossil	P28
◆ Greige	T5
◆ Light Gray	Q
◆ Loft	LOFT
◆ Muslin	T3
◆ Putty	L
◆ Shadow*	SHDW
◆ Titanium	P8T
P2	
◆ Champagne Metallic	T4
◆ Platinum Metallic	T1
◆ Silver	PR6
◆ Solar Black	P8X
P3	
◆ Atom	P8S
◆ Bullseye	PJF
◆ Ember	P8P
◆ Ion	P8N
◆ Iris	P8J
◆ Krypton	P8F
◆ Regatta	P8M

CONTAIN® PRODUCTS

L1 LAMINATES	CODES
Woodgrain	
◆ Bourbon Cherry	H
◆ Cognac	COGN
◆ Florence Walnut	LFW1
◆ Harvest	C
◆ Kingswood Walnut	LK11
◆ Mahogany	N
◆ Mocha	MOCH
◆ Natural Maple	D
◆ Pinnacle	PINC
◆ Shaker Cherry	F
◆ Sterling Ash	LSA1
L2 LAMINATES	CODES
Woodgrain	
◆ Lowell Ash	LLA1
◆ Natural Recon	LN1
◆ Phantom Ecru	LPE1
◆ Portico Teak	LPT1
◆ Skyline Walnut	LSW1

OPTIONAL LAMINATE TOPS FOR LATERAL FILES AND CONTAIN® CREDENZAS





L1 LAMINATES	CODES
Woodgrain	
◆ Bourbon Cherry	H
◆ Cognac	COGN
◆ Florence Walnut	LFW1
◆ Harvest	C
◆ Kingswood Walnut	LK11
◆ Mahogany	N
◆ Mocha	MOCH
◆ Natural Maple	D
◆ Pinnacle	PINC
◆ Shaker Cherry	F
◆ Sterling Ash	LSA1
Solid	
◆ Charcoal	S
◆ Designer White	LDW1
◆ Loft	LOFT
Patterned	
◆ Sheer Mesh*	A5
◆ Silver Mesh*	B9
◆ Steel Mesh*	A9
◆ Canyon Zephyr	K9
◆ Desert Zephyr	K8
◆ Shadow Zephyr	K1
◆ Gray*	G2
◆ White*	G1
L2 LAMINATES	CODES
Woodgrain	
◆ Lowell Ash	LLA1
◆ Natural Recon	LN1
◆ Phantom Ecru	LPE1
◆ Portico Teak	LPT1
◆ Skyline Walnut	LSW1

CONTAIN® PRODUCTS FRONT PAINT

PAINTS	CODES
P1	
◆ Black	P
◆ Brownstone	P7D
◆ Charcoal	S
◆ Designer White	PJW
◆ Fossil	P28
◆ Greige	T5
◆ Light Gray	Q
◆ Loft	LOFT
◆ Muslin	T3
◆ Putty	L
◆ Shadow*	SHDW
◆ Titanium	P8T
P2	
◆ Champagne Metallic	T4
◆ Platinum Metallic	T1
◆ Silver	PR6
◆ Solar Black	P8X
P3	
◆ Atom	P8S
◆ Bullseye	PJF
◆ Ember	P8P
◆ Ion	P8N
◆ Iris	P8J
◆ Krypton	P8F
◆ Regatta	P8M

NOTES: L2 laminate front upcharge is \$35 per list unit.

PULL OPTIONS FOR CONTAIN® AND FLAGSHIP® STORAGE

"A"	"N"	"R"	"S"
			
Satin Chrome Arch Pull	Full Face Integral Drawer Pull	Full Radius Drawer Pull	Square Drawer Pull

NOTES: Arch Pulls available in Satin Chrome only. Linear Pull coming soon.

* Laminate colors will have the following pre-set edgeband colors:

Laminate	Edge
Sheer Mesh	Muslin
Silver Mesh	Loft
Steel Mesh	Charcoal
Gray	Charcoal
White	Charcoal

Edgeband matches top except as noted.

For Champagne Metallic Paint, Muslin is the suggested edgeband color. When Champagne Metallic Paint is selected, pulls are standard in Muslin.

◆◆◆ For lead time information see page 19.

* De-emphasized

METAL CRENZAS WITH PANEL FRAMES

Guidelines for using Contain[®] Credenzas in place of standard panel systems configurations

Side-mounted Credenzas

Use 1 storage-to-panel bracket set.

The minimum credenza size is 22"H x 36"W x 18"D.

With a mid-run floor support, the maximum panel run is 144".

Without a mid-run panel attached floor support, the maximum panel run is 96".

Overheads and shelves cannot be used with 22"H side mounted credenzas.

Worksurfaces (if specified) must be mounted on the same side of the parent run as the credenzas.

Panel frame maximum height is 68".

Counterweight is required, if using unit with drawers.

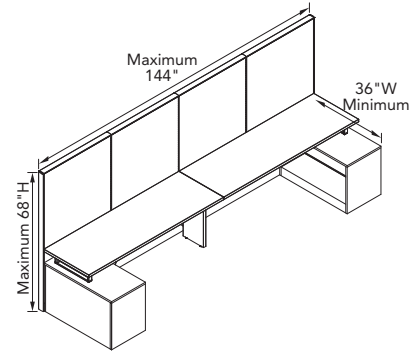

Back-mounted Credenzas — Modular

Use 2 storage-to-panel bracket sets per Credenza — 2 LH and 2 RH.

The minimum credenza size is 22"H x 36"W x 18"D.

The maximum panel run between back-mounted credenzas is 60".

Overheads and shelves cannot be used with 22"H back mounted credenzas.

Worksurfaces (if specified) must be mounted on the same side of the parent run as the credenzas.

Panel frame maximum height is 68".

Counterweights are required in a single side run configuration as shown.

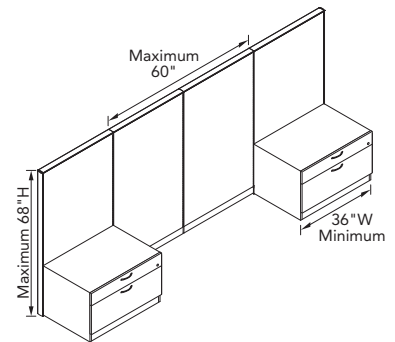

Side-mounted Credenzas — with Return Panel

Use 1 storage-to-panel bracket on Credenza LH or RH of set.

The minimum credenza size is 22"H x 36"W x 18"D.

The minimum size for panel return is 35"H x 36"W.

With a mid-run panel attached floor support, the maximum panel run is 144".

Without a mid-run floor support, the maximum panel run is 96".

Overheads and shelves cannot be used with 22"H side mounted credenzas.

Worksurfaces (if specified) must be mounted on the same side of the parent run as the credenzas.

Panel frame maximum height is 68".

Counterweight is required, if using unit with drawers.

Mid-run floor support options include:

Back-to-Back Credenzas

Panel Attached O-legs

Panel Attached Support Legs

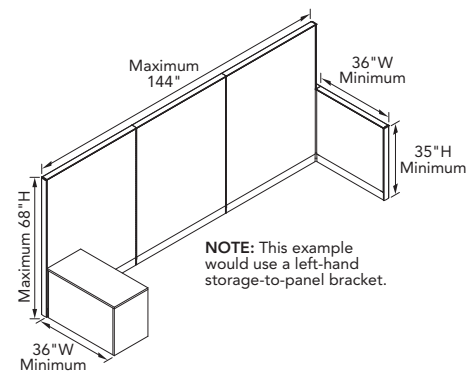

COUNTERWEIGHT REQUIREMENTS FOR CONTAIN[®] CRENZAS

Series	24"W Box/File Unit	30"W Box/File Unit	36"W Box/File Unit	42"W Combo Unit	48"W Combo Unit	60"W Combo Unit	72"W Combo Unit
18"D	HSCACW35 35 lbs. (two 12½ lb. and two 5 lb. counterweights)	HSCACW50 50 lbs. (four 12½ lb. counterweights)	HSCACW50 50 lbs. (four 12½ lb. counterweights)	HSCACW25 25 lbs. (two 12½ lb. counterweights)	HSCACW25 25 lbs. (two 12½ lb. counterweights)	HSCACW35 35 lbs. (two 12½ lb. and two 5 lb. counterweights)	HSCACW35 35 lbs. (two 12½ lb. and two 5 lb. counterweights)

Counterweight is not required if credenzas are used within a standard Systems set up and attached with the Credenza Storage-to-Panel Brackets.

CONTAIN[®] Metal Credenzas

GSA SIN 33721



Icon Legend on page 19

STORAGE

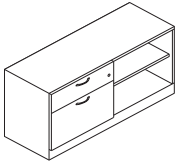
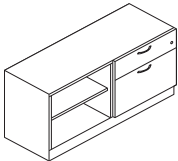
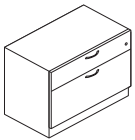
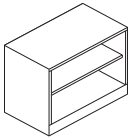
	DESCRIPTION	MODEL	SHIP WEIGHT	CUBE	LIST PRICE BY PAINT GRADE		
					P1	P2	P3
	Low Credenza, Box/Lateral Left, Open Shelf Right						
	72"W x 18"D x 22"H	HSCP227218RBFOM	150	20.7	\$1946	\$2013	\$2081
	60"W x 18"D x 22"H	HSCP226018RBFOM	130	17.3	\$1755	\$1822	\$1890
	48"W x 18"D x 22"H	HSCP224818RBFOM	111	14.0	\$1618	\$1685	\$1753
	Low Credenza, Box/Lateral Right, Open Shelf Left						
	72"W x 18"D x 22"H	HSCP227218LBFOM	150	20.7	\$1946	\$2013	\$2081
	60"W x 18"D x 22"H	HSCP226018LBFOM	130	17.3	\$1755	\$1822	\$1890
	48"W x 18"D x 22"H	HSCP224818LBFOM	111	14.0	\$1618	\$1685	\$1753
	Low Credenza, Box/Lateral						
	36"W x 18"D x 22"H	HSCP223618BFM	87	10.6	\$1190	\$1223	\$1258
	30"W x 18"D x 22"H	HSCP223018BFM	76	9.0	\$1140	\$1173	\$1208
	Open Shelf						
	36"W x 18"D x 22"H	HSCP223618O	66	10.6	\$847	\$880	\$915
	30"W x 18"D x 22"H	HSCP223018O	60	9.0	\$781	\$814	\$849

NOTES:

- Metal chassis and drawer fronts.
- Lateral and wide box drawers operate on ball-bearing suspension with full extension.
- Steel ball-bearing drawer suspensions.
- Ships complete with standard kickplate.
- Field installable counterweight sold separately.
- File drawers accept hanging folders in letter or legal size.
- Steel frame provides durability.
- Use with laminate tops and credenza seat cushions. Order separately — see pages 649-650.

⚠ Locking units equipped with HON "One Key" interchangeable core removable locks. Keyed alike core model HF23S, in Satin, must be ordered separately. See page 649.

HOW TO SPECIFY

Select Model Number H S C P 2 2 3 6 1 8 O .	Select Base BK Flush Plinth BX Recessed Plinth B K .	Select Case Paint See page 640 P J W .	Select Shelf Paint See page 640 P J W .			
Select Model Number H S C P 2 2 7 2 1 8 R B F O M .	Select Base BK Flush Plinth BX Recessed Plinth B K .	Select Pull A Arch PRO Silver R Radius N Integral S Square PR6 Silver A P R O .	Select Case Paint See page 640 P J W .	Select Front Paint NA Matches Case N A .	Select Shelf Paint See page 640 Not specified for models HSCP223018BFM and HSCP223618BFM P J W .	Select Lock L Standard Lock X Omit Lock (- \$20) Not specified for models HSCP223618O and HSCP223018O L



Icon Legend on page 19

CONTAIN® Footed Metal Credenzas

	DESCRIPTION	MODEL	SHIP WEIGHT	CUBE	LIST PRICE BY PAINT GRADE		
					P1	P2	P3
	Footed Low Credenza, Box/Lateral Left, Open Shelf Right						
	72"W x 18"D x 22"H	HSCF227218RBFOM	150	17.7	\$2102	\$2169	\$2237
	60"W x 18"D x 22"H	HSCF226018RBFOM	130	14.9	\$1913	\$1980	\$2048
	48"W x 18"D x 22"H	HSCF224818RBFOM	111	12.0	\$1745	\$1812	\$1880
	Footed Low Credenza, Box/Lateral Right, Open Shelf Left						
	72"W x 18"D x 22"H	HSCF227218LBFOM	150	17.7	\$2102	\$2169	\$2237
	60"W x 18"D x 22"H	HSCF226018LBFOM	130	14.9	\$1913	\$1980	\$2048
	48"W x 18"D x 22"H	HSCF224818LBFOM	111	12.0	\$1745	\$1812	\$1880
	Footed Low Credenza, Box/Lateral						
	36"W x 18"D x 22"H	HSCF223618BFM	87	9.1	\$1316	\$1349	\$1384
	30"W x 18"D x 22"H	HSCF223018BFM	76	7.7	\$1265	\$1298	\$1333
	Footed Open Shelf						
	36"W x 18"D x 22"H	HSCF223618O	66	9.1	\$974	\$1007	\$1042
	30"W x 18"D x 22"H	HSCF223018O	60	7.7	\$907	\$940	\$975

STORAGE

NOTES:

- Lateral and wide box drawers operate on ball-bearing suspension with full extension.
- Steel ball-bearing drawer suspensions.
- Ships complete with standard footed base.
- Field installable counterweight sold separately.
- File drawers accept hanging folders in letter or legal size.
- Steel frame provides durability.
- Feet are shipped with the credenza unit and are easily assembled.
- Use with laminate tops and credenza seat cushions. Order separately — see pages 649-650.

ⓘ Locking units equipped with HON "One Key" interchangeable core removable locks. Keyed alike core model HF23S, in Satin, must be ordered separately. See page 649.

HOW TO SPECIFY

<p>Select Model Number</p> <p>HSCF223618O</p>	<p>Select Foot</p> <p>SF Contain Foot T1 Platinum Metallic PR6 Silver</p> <p>SFT1</p>	<p>Select Case Paint</p> <p>See page 640</p> <p>PJW</p>	<p>Select Shelf Paint</p> <p>See page 640</p> <p>PJW</p>
--	--	--	---

<p>Select Model Number</p> <p>HSCF227218RBFOM</p>	<p>Select Foot</p> <p>SF Contain Foot T1 Platinum Metallic PR6 Silver</p> <p>SFT1</p>	<p>Select Pull</p> <p>A Arch PRO Silver R Radius N Integral S Square PR6 Silver</p> <p>APRO</p>	<p>Select Case Paint</p> <p>See page 640</p> <p>PJW</p>	<p>Select Front Paint</p> <p>NA Matches Case</p> <p>NA</p>	<p>Select Shelf Paint</p> <p>See page 640 Not specified for models HSCF223618BFM and HSCF223018BFM</p> <p>PJW</p>	<p>Select Lock</p> <p>L Standard Lock X Omit Lock (- \$20) Not specified for models HSCF223618O and HSCF223018O</p> <p>L</p>
--	--	--	--	---	--	---

CONTAIN[®] Metal Credenzas with Laminate Fronts

GSA SIN 33721



Icon Legend on page 19

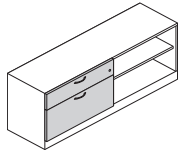

DESCRIPTION

Metal Low Credenza, Laminate Front, Box/Lateral Left, Open Shelf Right
72"W x 18"D x 22"H
60"W x 18"D x 22"H
48"W x 18"D x 22"H

MODEL

HSCP227218RBFOL
HSCP226018RBFOL
HSCP224818RBFOL

SHIP WEIGHT

CUBE

LIST PRICE BY PAINT GRADE

P1 P2 P3

152 20.7 **\$2158** **\$2225** **\$2293**
132 17.3 **\$1968** **\$2035** **\$2103**
113 14.0 **\$1831** **\$1898** **\$1966**

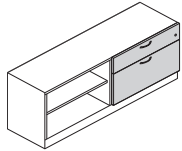

Metal Low Credenza, Laminate Front, Box/Lateral Right, Open Shelf Left
72"W x 18"D x 22"H
60"W x 18"D x 22"H
48"W x 18"D x 22"H

HSCP227218LBFOL
HSCP226018LBFOL
HSCP224818LBFOL

152 20.7 **\$2158** **\$2225** **\$2293**
132 17.3 **\$1968** **\$2035** **\$2103**
113 14.0 **\$1831** **\$1898** **\$1966**

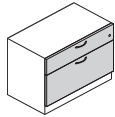

Metal Low Credenza, Laminate Front Box/Lateral
36"W x 18"D x 22"H
30"W x 18"D x 22"H

HSCP223618BFL
HSCP223018BFL

89 10.6 **\$1403** **\$1436** **\$1471**
76 9.0 **\$1352** **\$1385** **\$1420**

NOTES:

- Lateral and wide box drawers operate on ball-bearing suspension with full extension.
- Steel ball-bearing drawer suspensions.
- Ships complete with standard kickplate.
- Field installable counterweight sold separately.
- File drawers accept hanging folders in letter or legal size.
- Steel frame provides durability.
- Use with laminate tops and credenza seat cushions. Order separately — see pages 649-650.

ⓘ Locking units equipped with HON "One Key" interchangeable core removable locks. Keyed alike core model HF23S, in Satin, must be ordered separately. See page 649.

HOW TO SPECIFY

Select Model Number	Select Base	Select Pull	Select Case Paint	Select Laminate	Select Shelf Paint	Select Lock
	BX Recessed Plinth	A Arch PRO Silver S Square PR6 Silver	See page 640	See page 640	See page 640 Not specified for models HSCP223618BFL and HSCP223018BFL	L Standard Lock X Omit Lock (- \$20)
H S C P 2 2 7 2 1 8 R B F O L .	B X .	A P R O .	P J W .	L S A 1 .	P J W .	L



Icon Legend on page 19

Footed Metal Credenzas with Laminate Fronts

	DESCRIPTION	MODEL	SHIP WEIGHT	CUBE	LIST PRICE BY PAINT GRADE		
					P1	P2	P3
	Footed Low Credenza, Laminate Front, Box/Lateral Left, Open Shelf Right						
	72"W x 18"D x 22"H	HSCF227218RBFOL	152	17.7	\$2316	\$2383	\$2451
	60"W x 18"D x 22"H	HSCF226018RBFOL	132	14.9	\$2124	\$2191	\$2259
	48"W x 18"D x 22"H	HSCF224818RBFOL	113	12.0	\$1957	\$2024	\$2092
	Footed Low Credenza, Laminate Front, Box/Lateral Right, Open Shelf Left						
	72"W x 18"D x 22"H	HSCF227218LBFOL	152	17.7	\$2316	\$2383	\$2451
	60"W x 18"D x 22"H	HSCF226018LBFOL	132	14.9	\$2124	\$2191	\$2259
	48"W x 18"D x 22"H	HSCF224818LBFOL	113	12.0	\$1957	\$2024	\$2092
	Footed Low Credenza, Laminate Front Box/Lateral						
	36"W x 18"D x 22"H	HSCF223618BFL	89	9.1	\$1528	\$1561	\$1596
	30"W x 18"D x 22"H	HSCF223018BFL	78	7.7	\$1479	\$1512	\$1547

STORAGE

NOTES:

- Lateral and wide box drawers operate on ball-bearing suspension with full extension.
- Steel ball-bearing drawer suspensions.
- Ships complete with standard footed base.
- Field installable counterweight sold separately.
- File drawers accept hanging folders in letter or legal size.
- Steel frame provides durability.
- Feet are shipped with the credenza unit and are easily assembled.
- Use with laminate tops and credenza seat cushions. Order separately — see pages 649-650.

! Locking units equipped with HON "One Key" interchangeable core removable locks. Keyed alike core model HF23S, in Satin, must be ordered separately. See page 649.

HOW TO SPECIFY

Select Model Number	Select Foot	Select Pull	Select Case Paint	Select Laminate	Select Shelf Paint	Select Lock
	SF Contain Foot T1 Platinum Metallic PR6 Silver	A Arch PRO Silver S Square PR6 Silver	See page 640	See page 640	See page 640 Not specified for models HSCF223618BFL and HSCF223018BFL	L Standard Lock X Omit Lock (- \$20)
HSCF227218RBFOL	SFT1	APRO	PJW	LSA1	PJW	L



CONTAIN® Personal Files

OPEN MARKET

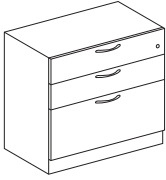

Icon Legend on page 19

STORAGE

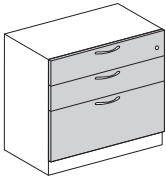
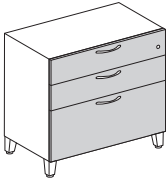
	DESCRIPTION	MODEL	SHIP WEIGHT	CUBE	LIST PRICE BY PAINT GRADE		
					P1	P2	P3
	Box/Box/File 30"W x 18"D x 28"H	HSFCP283018BBFM	90	11.3	\$1318	\$1351	\$1386
	Footed, Box/Box/File 30"W x 18"D x 28"H	HSFCF283018BBFM	90	11.3	\$1449	\$1482	\$1517
	Box/Box/File, Laminate Front Base 30"W x 18"D x 28"H	HSFCP283018BBFL	90	11.3	\$1515	\$1548	\$1583
	Footed, Box/Box/File, Laminate Front 30"W x 18"D x 28"H	HSFCF283018BBFL	90	11.3	\$1647	\$1680	\$1715

NOTES:

- Lateral and wide box drawers operate on ball-bearing suspension with full extension.
- Steel ball-bearing drawer suspensions.
- Field installable counterweight sold separately.
- File drawers accept hanging folders in letter or legal size.
- Steel frame provides durability.

! Locking units equipped with HON "One Key" interchangeable core removable locks.

HOW TO SPECIFY



<p>Select Model Number</p> <p>HSFCP283018BBFM</p>	<p>Select Base</p> <p>BK Flush Plinth BX Recessed Plinth</p> <p>BK</p>	<p>Select Pull</p> <p>A Arch PRO Silver R Radius N Integral S Square PR6 Silver</p> <p>APRO</p>	<p>Select Case Paint</p> <p>See page 640</p> <p>PJW</p>	<p>Select Front Paint</p> <p>NA Matches Case</p> <p>NA</p>	<p>Select Lock</p> <p>L Standard Lock X Omit Lock (- \$20)</p> <p>L</p>
--	---	--	--	---	--

<p>Select Model Number</p> <p>HSFCF283018BBFL</p>	<p>Select Foot</p> <p>SF Contain Foot T1 Platinum Metallic PR6 Silver</p> <p>SFT1</p>	<p>Select Pull</p> <p>A Arch PRO Silver S Square PR6 Silver</p> <p>APRO</p>	<p>Select Case Paint</p> <p>See page 640</p> <p>PJW</p>	<p>Select Laminate</p> <p>See page 640</p> <p>LSA1</p>	<p>Select Lock</p> <p>L Standard Lock X Omit Lock (- \$20)</p> <p>L</p>
--	--	--	--	---	--

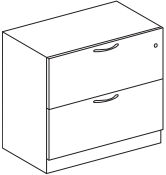

Icon Legend on page 19

CONTAIN® Lateral Files

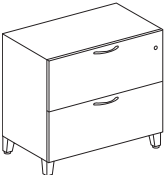
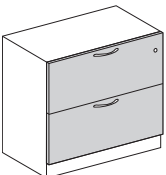
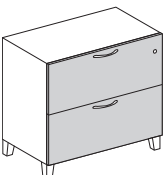
	DESCRIPTION	MODEL	SHIP WEIGHT	CUBE	LIST PRICE BY PAINT GRADE		
					P1	P2	P3
	2 Drawer Lateral						
	30"W x 18"D x 28"H 36"W x 18"D x 28"H	HSLP283018FFM HSLP283618FFM	90 101	11.3 13.4	\$1025 \$1205	\$1058 \$1238	\$1093 \$1273
	 Replace (?) with handle choice.						
	Footed 2 Drawer Lateral						
	30"W x 18"D x 28"H 36"W x 18"D x 28"H	HSLF283018FFM HSLF283618FFM	90 101	11.3 13.4	\$1200 \$1325	\$1233 \$1358	\$1268 \$1393
	2 Drawer Lateral, Laminate Front						
	30"W x 18"D x 28"H 36"W x 18"D x 28"H	HSLP283018FFL HSLP283618FFL	98 109	11.3 13.4	\$1269 \$1385	\$1302 \$1418	\$1337 \$1453
	Footed 2 Drawer Lateral, Laminate Front						
	30"W x 18"D x 28"H 36"W x 18"D x 28"H	HSLF283018FFL HSLF283618FFL	98 109	11.3 13.4	\$1385 \$1523	\$1418 \$1556	\$1453 \$1591

STORAGE

NOTES:

- Lateral and wide box drawers operate on ball-bearing suspension with full extension.
- Steel ball-bearing drawer suspensions.
- Field installable counterweight sold separately.
- File drawers accept hanging folders in letter or legal size.
- Steel frame provides durability.
- Contain® Laterals can be used with Storage Islands.

 Locking units equipped with HON "One Key" interchangeable core removable locks.

HOW TO SPECIFY

Select Model Number	Select Base BK Flush Plinth BX Recessed Plinth	Select Pull A Arch PRO Silver R Radius N Integral S Square PR6 Silver	Select Case Paint See page 640	Select Front Paint NA Matches Case	Select Lock L Standard Lock X Omit Lock (- \$20)
H S L P 2 8 3 0 1 8 F F M .	B K .	A P R O .	P J W .	N A .	L .

Select Model Number	Select Foot SF Contain Foot T1 Platinum Metallic PR6 Silver	Select Pull A Arch PRO Silver S Square PR6 Silver	Select Case Paint See page 640	Select Laminate See page 640	Select Lock L Standard Lock X Omit Lock (- \$20)
H S L F 2 8 3 0 1 8 F F L .	S F T 1 .	A P R O .	P J W .	L S A 1 .	L .

CONTAIN[®] Lateral File Accessories

GSA SIN AS NOTED



Icon Legend on page 19

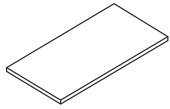

SIN 33721

DESCRIPTION

Credenza Laminate Top — Square Edge

72"W x 18"D x 1/8" Thick
60"W x 18"D x 1/8" Thick
48"W x 18"D x 1/8" Thick
36"W x 18"D x 1/8" Thick
30"W x 18"D x 1/8" Thick

MODEL	SHIP WEIGHT	CUBE	LIST PRICE BY LAMINATE GRADE	
			L1	L2
H919472	48	3.5	\$829	\$844
H919460	32	3.0	\$706	\$721
H919448	31	2.6	\$619	\$629
H919436	25	1.8	\$512	\$522
H919430	20	1.6	\$408	\$418

NOTES: Square-edge laminate tops provide a finished look to credenzas. See Storage Islands on page 702 for full laminate solution.

Specify laminate only.

SPECIFYING EXAMPLE: H919448.C

DESCRIPTION

Front-to-Back Hangrail Kits

15"D for 24"D Credenza or 18"D Lateral

No specification needed.

MODEL	SHIP WEIGHT	CUBE	LIST PRICE
HSCAHR15	0.1	0.2	\$22



OPEN MARKET

Counterweight for Contain 28"H Laterals

50 lbs for 30" Lateral
57½ lbs for 36" Lateral

MODEL	SHIP WEIGHT	CUBE	LIST PRICE
HSLACW50	2.0	55.0	\$206
HSLACW57	2.0	63.0	\$216

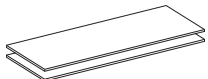

OPEN MARKET

Field Installable Drawer/Door Handle Kits

Field Installable Pull, 2 Pack
Field Installable Pull, 3 Pack

MODEL	SHIP WEIGHT	CUBE	LIST PRICE
HPULL2	0.4	0.3	\$56
HPULL3	0.5	0.3	\$64

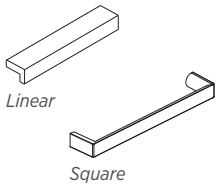

NOTES: Square and Linear pull packs provide the option to coordinate with Fuse™ Storage. Pull packs are field installable on all Contain® Storage Products, excluding electronic locking units.

HOW TO SPECIFY

Select Model Number

H919472.

Select Laminate Color

See page 640

C

Select Model Number

HSLACW50.

Select Paint Color

See page 640

S

Select Model Number

HPULL2.

Select Pull Style and Color

LP Linear Black
LPR6 Linear Silver
SPR6 Square Silver

LPR6



CONTAIN® Metal Credenzas Accessories

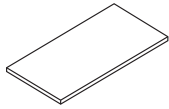

DESCRIPTION	MODEL	SHIP WEIGHT	CUBE	LIST PRICE BY LAMINATE GRADE	
				L1	L2
Credenza Laminate Top — Square Edge					
72"W x 18"D x 1/8" Thick	H919472	48.0	3.5	\$829	\$844
60"W x 18"D x 1/8" Thick	H919460	32.0	3.0	\$706	\$721
48"W x 18"D x 1/8" Thick	H919448	31.0	2.6	\$619	\$629
36"W x 18"D x 1/8" Thick	H919436	25.0 Ⓢ	1.8	\$512	\$522
30"W x 18"D x 1/8" Thick	H919430	20.0 Ⓢ	1.6	\$408	\$418

NOTES: Square-edge laminate tops provide a finished look to credenzas.

! Specify laminate only.

SPECIFYING EXAMPLE: H919448.C

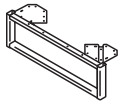

DESCRIPTION	MODEL	SHIP WEIGHT	CUBE	LIST PRICE BY PAINT GRADE		
				P1	P2	P3
Worksurface O-Leg						
30"W x 6 1/2"H	HSCAWS6530	7.0	1.0	\$228	\$238	\$243
24"W x 6 1/2"H	HSCAWS6524	6.0	1.0	\$191	\$201	\$206
20"W x 6 1/2"H	HSCAWS6520	5.0	1.0	\$165	\$175	\$180

NOTES: Worksurfaces with O-Legs may be placed upon Low Credenzas to create layering.

! Specify paint only.

SPECIFYING EXAMPLE: HSCAWS6530.S



Credenza Kickplates						
For 36" Box/File Model	HSCCK36BF	3.0	0.5	\$131	\$141	\$156
For 30" Box/File Model	HSCCK30BF	2.0	0.4	\$121	\$131	\$146
For 24" Box/File Model	HSCCK24BF	2.0	0.4	\$108	\$118	\$133
For 36" Open File Model	HSCCK360	3.0	0.5	\$131	\$141	\$156
For 30" Open File Model	HSCCK300	2.0	0.4	\$121	\$131	\$146

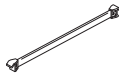

Credenza Hangrail Kits						
12" for front-to-back filing	HSCAHR12	1.0 Ⓢ	0.4	\$19	N/A	N/A

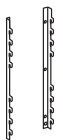

Credenza Storage-to-Panel Bracket	HSCAPB	0.2 Ⓢ	0.4	\$198	\$210	\$218
--	---------------	--------------	-----	-------	-------	-------

Credenza Counterweight Kit

HSCACW50	55.0 Ⓢ	2.0	\$220	N/A	N/A
HSCACW35	40.0 Ⓢ	2.0	\$199	N/A	N/A
HSCACW25	30.0 Ⓢ	2.0	\$177	N/A	N/A

NOTES: Field installable counterweight sold separately.

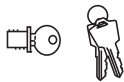

Removable Lock Core Kit—Satin	HF23S	0.2 Ⓢ	0.1	\$42	N/A	N/A
--------------------------------------	--------------	--------------	-----	------	-----	-----

- Use when specifying omit lock application.
- Specify quantity of each key number from 101E-225E.
- Includes: 1-core, 2-keys, 1-core removal tool and instructions.
- Removable lock core kits with specific key number must be ordered to facilitate keying alike in the field.
- For specific models, look for the Omit Lock Core icon throughout this publication.

NOTES: If key number isn't specified, number will be at random. Core matches manufactured lock on Contain® product but can be used with Contain® metal casegoods and laminate product.

HOW TO SPECIFY

<p>Select Model Number</p> <p>H 9 1 9 4 4 8 .</p>	<p>Select Laminate Color</p> <p>See page 640</p> <p>C</p>
<p>Select Model Number</p> <p>H S C A W S 6 5 3 0 .</p>	<p>Select Paint Color</p> <p>See page 640</p> <p>S</p>

STORAGE

CONTAIN[®] Metal Credenzas Accessories

GSA SIN 33721



Icon Legend on page 19

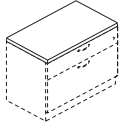

DESCRIPTION	MODEL	SHIP WEIGHT	CUBE	SHIP											
				1	2	3	4	5	6	7	8	9	10	11	12
Credenza Cushion 36"W x 18"D for 36", 60", and 72" Credenzas	HSCAUC1836	16.3	1.6	\$282	\$320	\$358	\$397	\$446	\$496	\$546	\$595	\$645	\$694	\$744	\$794
30"W x 18"D for 30", 48", and 60" Credenzas	HSCAUC1830	16.3	1.6	\$263	\$301	\$339	\$378	\$427	\$477	\$527	\$576	\$626	\$675	\$725	\$775
24"W x 18"D for 48" Credenzas	HSCAUC1824	16.3	1.9	\$246	\$284	\$322	\$361	\$410	\$460	\$510	\$559	\$609	\$658	\$708	\$758

NOTES: See pages 22-24 for available fabrics.
SPECIFYING EXAMPLE: HSCAUC1836.APN23

NOTES:

- For matching Pedestal Seats, see page 674.
- Credenza Cushions are available in 24", 30" and 36" size options.
- Choose from multiple upholstery options, see pages 22-24.

HOW TO SPECIFY

Select
Model Number

Select
Fabric

See pages 22-24

H S C A U C 1 8 3 6 .

C U 1 0

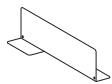

DESCRIPTION

Metal Box Divider

10 pack
2 pack

! Metal dividers available in Black only. No need to specify.

MODEL

HSCABD10
HSCABD02

SHIP WEIGHT

7
2

CUBE

0.7
0.7

LIST PRICE P1

\$170
\$43

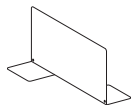

DESCRIPTION

Metal File Divider

10 pack
2 pack

! Metal dividers available in Black only. No need to specify.

HSCAFD10
HSCAFD02

12
3

0.7
0.7

\$202
\$53

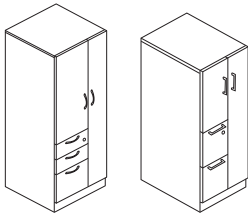

Metal Personal Towers with Plinth Base

65", 50", 42"H
24", 18"W
24"D

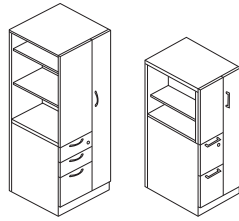

Metal Side-Access Personal Towers with Plinth Base

65", 50", 42"H
24", 18"W
24"D

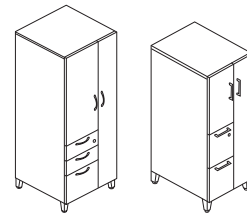

Metal Personal Towers with Footed Base

65", 50", 42"H
24", 18"W
24"D

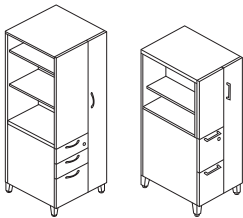

Metal Personal Towers with Footed Base

65", 50", 42"H
24", 18"W
24"D

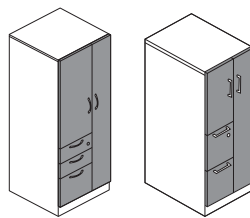

Metal Personal Towers with Laminate Fronts, Plinth Base

65", 50", 42"H
24", 18"W
24"D

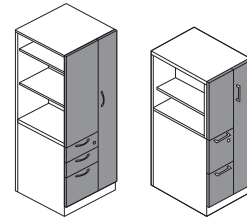

Metal Side-Access Personal Towers with Laminate Fronts, Plinth Base

65", 50", 42"H
24", 18"W
24"D

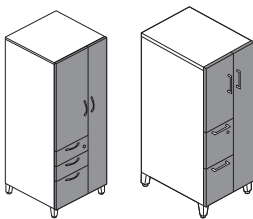

Metal Personal Towers with Laminate Fronts, Footed Base

65", 50", 42"H
24", 18"W
24"D

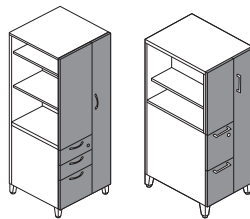

Metal Side-Access Towers with Laminate Fronts, Footed Base

65", 50", 42"H
24", 18"W
24"D

NOTES:

- ❗ 18"W Tower models available in File/File configuration only.
- ❗ 24"W Tower models available in both Box/Box/File and File/File configurations.

CONTAIN[®] Lockers & Wardrobes

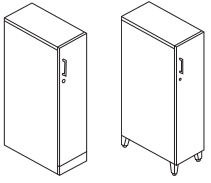

Wardrobe Tower with Metal Front

65", 50", 42"H
12"W
24", 18"D

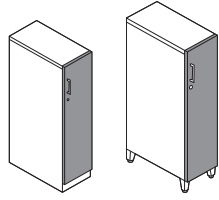

Wardrobe Tower with Laminate Front

65", 50", 42"H
12"W
24", 18"D

STORAGE

NOTES:

- Available with Plinth Base or Footed.
- Doors available hinged left or right.

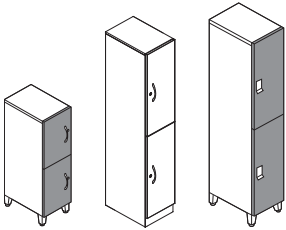

Double Locker, Metal or Laminate Fronts

65"H x 12"W x 18"D, Two Doors
45"H x 12"W x 18"D, Two Doors

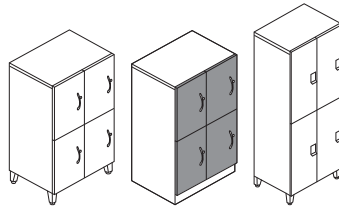

Quad Locker, Metal or Laminate Fronts

65"H x 24"W x 18"D, Four Doors
45"H x 24"W x 18"D, Four Doors

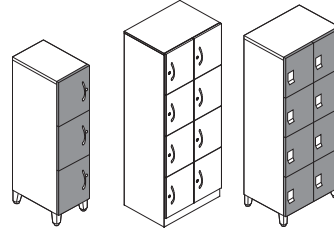

Cubby Locker, Metal or Laminate Fronts

65"H x 12"W x 18"D, Four Doors
50"H x 12"W x 18"D, Three Doors
65"H x 24"W x 18"D, Eight Doors
50"H x 24"W x 18"D, Six Doors

NOTES:

- Available with Flush or Recessed Plinth, or Footed.
- Doors available hinged left or right.
- Electronic Keypad or RFID Lock Pulls available to be specified on all sizes (upcharges apply).

CONTAIN® DIGITAL LOCK SPECIFICATIONS

Digital Keypad & RFID Lock Specification Information for Contain® Lockers

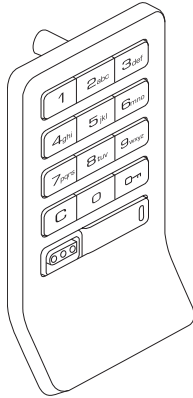

Keypad Lock Pull

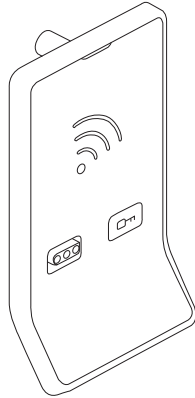

RFID Lock Pull

The digital keypad and RFID lock options support applications where workstations or storage areas are shared by multiple users. This is an alternative to a standard lock and key. This feature facilitates the use of storage by multiple users through eliminating the need to keep and hand-off physical keys. These locks ship in “shared mode” by default; shared mode indicates that the lock will “forget” the paired 4-digit code or RFID badge after the lock is opened, allowing the unit to be used by multiple users.

❗ Order at least one Programming Key and Manager Key per install.

Digital Keypad & RFID Locks:

- Offered on Contain® lockers.
- Ship factory installed.
- Integral Pull/Lock design replaces a specified pull on eLock models.
- Offered in a polished silver finish.
- Digital keypad lock requires input of a user-selected 4-digit code.
- RFID lock requires a compatible RFID card or sticker.
- Digital keypad locks and RFID locks are powered using 4 premium AA batteries.
- Battery life is dependent on the frequency of operation but can last up to 5-7 years.

RFID locks require user to present a compatible RFID card or sticker to the lock in order to gain access. This is the same technology as “badge” systems that allows employers to grant employees with cards that can be scanned to gain access to entrances and buildings. HON locks *may or may not be* compatible with these existing badge systems.

- For existing RFID badge system compatibility, badges must operate on a 13.56 MHz frequency with both iClass (ISO 15693) and Mifare (ISO 14443).
- If existing badge system is not compatible with 13.56 MHz frequency, compatible RFID badges or RFID stickers are sold separately as an accessory model.

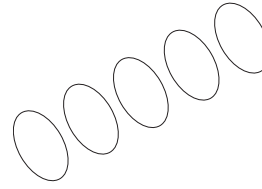

RFID Lock Pull

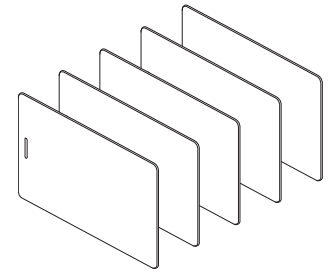

RFID Cards

Digital Lock Accessory Models (page 672)

- RFID-compatible cards and stickers are sold as accessory models in increments of 5, 25, or 100.
- RFID cards are plain white and have a lanyard cut.
- RFID stickers are plain white, approximately 1” in diameter and may be added to the back of an existing badge or employee identification card.
- **Every digital keypad or RFID installation site will require one Programming Key and at least one Manager Key, sold separately.**

Programming Key

- A Programming Key is a device used to initialize locks out of factory default mode and register Manager Keys to the locks.
- Only one Programming Key should be specified per installation site because multiple Programming Keys are not compatible with each other.
- Add-on digital lock orders should be programmed with the original Programming Key.
- Programming Key is the same key as Fuse™ Digilocks and can work across both Contain® and Fuse™.

Manager Key

- A Manager Key is used to bypass a locked unit; this operates as the “master key” and it is recommended that building facilitators have at least one Manager Key.
- Up to 6 Manager Keys may be registered to each lock.
- Manager Keys provide external power to locks in case of battery failure.

Digital Lock Keys and Accessories		
Description	Model	List Price
Programming Key	HSLDIGPRG	\$160
Manager Key	HSLDIGMGR	\$125
5 pk RFID Cards	HSLRFID5C	\$105
25 pk RFID Cards	HSLRFID25C	\$500
100 pk RFID Cards	HSLRFID100C	\$1,900
5 pk RFID Stickers	HSLRFID5S	\$55
25 pk RFID Stickers	HSLRFID25S	\$250
100 pk RFID Stickers	HSLRFID5100S	\$950

CONTAIN[®] Metal Personal Towers

GSA SIN 33721



Icon Legend on page 19

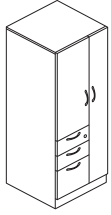

DESCRIPTION	MODEL	SHIP WEIGHT	CUBE	LIST PRICE BY CASE PAINT GRADE		
				P1	P2	P3
Personal Tower with Metal Fronts, Door/Box/Box/File						
65"H x 24"W x 24"D, Wardrobe Left	HSTP652424LBBFM	178	27.2	\$2046	\$2123	\$2191
65"H x 24"W x 24"D, Wardrobe Right	HSTP652424RBBFM	178	27.2	\$2046	\$2123	\$2191
50"H x 24"W x 24"D, Wardrobe Left	HSTP502424LBBFM	146	21.2	\$1915	\$1992	\$2060
50"H x 24"W x 24"D, Wardrobe Right	HSTP502424RBBFM	146	21.2	\$1915	\$1992	\$2060
42"H x 24"W x 24"D, Wardrobe Left	HSTP422424LBBFM	132	16.8	\$1645	\$1695	\$1770
42"H x 24"W x 24"D, Wardrobe Right	HSTP422424RBBFM	132	16.8	\$1645	\$1695	\$1770

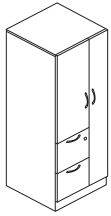

Personal Tower with Metal Fronts, Door/File/File						
65"H x 24"W x 24"D, Wardrobe Left	HSTP652424LFFM	178	27.2	\$1995	\$2072	\$2140
65"H x 24"W x 24"D, Wardrobe Right	HSTP652424RFFM	178	27.2	\$1995	\$2072	\$2140
50"H x 24"W x 24"D, Wardrobe Left	HSTP502424LFFM	146	21.1	\$1865	\$1942	\$2010
50"H x 24"W x 24"D, Wardrobe Right	HSTP502424RFFM	146	21.1	\$1865	\$1942	\$2010
42"H x 24"W x 24"D, Wardrobe Left	HSTP422424LFFM	132	16.8	\$1594	\$1644	\$1719
42"H x 24"W x 24"D, Wardrobe Right	HSTP422424RFFM	132	16.8	\$1594	\$1644	\$1719

NOTES:

- Metal chassis and drawer fronts.
- Steel frame provides durability.
- Leveling glides can be adjusted from outside or inside the case.
- Heavy-duty, telescoping ball-bearing slides.
- Baked, epoxy/polyester, powder coating finish.
- One lock secures doors and drawers.
- Pencil tray standard in top box drawer.
- One box divider standard in each box drawer.
- One crossrail standard in each file drawer.

! Locking units equipped with HON "One Key" interchangeable core removable locks. Keyed alike core model HF23S, in Satin, must be ordered separately. See page 649.

HOW TO SPECIFY

Select Model Number	Select Base	Select Pull	Select Case Paint	Select Front Paint	Select Lock
	BK Flush Plinth BX Recessed Plinth	A Arch PRO Silver R Radius N Integral S Square PR6 Silver	See page 640	See page 640 NA Matches Case (+ \$0) P1 upcharge (+ \$100) P2 upcharge (+ \$120) P3 upcharge (+ \$140)	L Standard Lock X Omit Lock (- \$20)
HSTP652424LFFM	BX	SPR6	P7T	NA	L



Icon Legend on page 19

CONTAIN[®] Metal Side Access Towers

	DESCRIPTION	MODEL	SHIP WEIGHT	CUBE	LIST PRICE BY CASE PAINT GRADE		
					P1	P2	P3
	Side Access Tower with Metal Fronts, Shelves/Box/Box/File						
	65"H x 24"W x 24"D, Wardrobe Left	HSTSP652424LBBFM	178	27.2	\$2167	\$2244	\$2312
	65"H x 24"W x 24"D, Wardrobe Right	HSTSP652424RBBFM	178	27.2	\$2167	\$2244	\$2312
	50"H x 24"W x 24"D, Wardrobe Left	HSTSP502424LBBFM	146	21.2	\$2029	\$2106	\$2174
	50"H x 24"W x 24"D, Wardrobe Right	HSTSP502424RBBFM	146	21.2	\$2029	\$2106	\$2174
	42"H x 24"W x 24"D, Wardrobe Left	HSTSP422424LBBFM	132	16.8	\$1831	\$1881	\$1956
	42"H x 24"W x 24"D, Wardrobe Right	HSTSP422424RBBFM	132	16.8	\$1831	\$1881	\$1956
	Side Access Tower with Metal Fronts, Shelves/File/File						
	65"H x 24"W x 24"D, Wardrobe Left	HSTSP652424LFFM	178	27.2	\$2117	\$2194	\$2262
	65"H x 24"W x 24"D, Wardrobe Right	HSTSP652424RFFM	178	27.2	\$2117	\$2194	\$2262
	50"H x 24"W x 24"D, Wardrobe Left	HSTSP502424LFFM	146	21.2	\$1978	\$2055	\$2123
	50"H x 24"W x 24"D, Wardrobe Right	HSTSP502424RFFM	146	21.2	\$1978	\$2055	\$2123
	42"H x 24"W x 24"D, Wardrobe Left	HSTSP422424LFFM	132	16.8	\$1780	\$1830	\$1905
	42"H x 24"W x 24"D, Wardrobe Right	HSTSP422424RFFM	132	16.8	\$1780	\$1830	\$1905

STORAGE

NOTES:

- Towers can be used to support a worksurface. In order to do so, order bracket model HSTB2W1.
- Metal chassis and drawer fronts.
- Steel frame provides durability.
- Leveling glides can be adjusted from outside or inside the case.
- Heavy-duty, telescoping ball-bearing slides.
- Baked, epoxy/polyester, powder coating finish.
- One lock secures doors and drawers.
- Pencil tray standard in top box drawer.
- One box divider standard in each box drawer.
- One crossrail standard in each file drawer.

ⓘ Locking units equipped with HON "One Key" interchangeable core removable locks. Keyed alike core model HF23S, in Satin, must be ordered separately. See page 649.

HOW TO SPECIFY

Select Model Number	Select Base	Select Pull	Select Case Paint	Select Front Paint	Select Panel Paint	Select Lock
	BK Flush Plinth BX Recessed Plinth	A Arch PRO Silver R Radius N Integral S Square PR6 Silver	See page 640	See page 640 NA Matches Case (+ \$0) P1 upcharge (+ \$100) P2 upcharge (+ \$120) P3 upcharge (+ \$140)	NA Matches Case	L Standard Lock X Omit Lock (- \$20)
H S T S P 6 5 2 4 2 4 L F F M .	B X .	S P R 6 .	P 7 T .	N A .	N A .	L

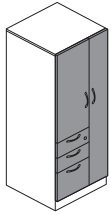

DESCRIPTION	MODEL	SHIP WEIGHT	CUBE	LIST PRICE BY PAINT GRADE		
				P1	P2	P3
Personal Tower with Laminate Fronts, Door/Box/Box/File						
65"H x 24"W x 24"D, Wardrobe Left	HSTP652424LBBFL	178	27.2	\$2344	\$2421	\$2489
65"H x 24"W x 24"D, Wardrobe Right	HSTP652424RBBFL	178	27.2	\$2344	\$2421	\$2489
50"H x 24"W x 24"D, Wardrobe Left	HSTP502424LBBFL	146	21.2	\$2195	\$2272	\$2340
50"H x 24"W x 24"D, Wardrobe Right	HSTP502424RBBFL	146	21.2	\$2195	\$2272	\$2340
42"H x 24"W x 24"D, Wardrobe Left	HSTP422424LBBFL	132	16.8	\$1884	\$1934	\$2009
42"H x 24"W x 24"D, Wardrobe Right	HSTP422424RBBFL	132	16.8	\$1884	\$1934	\$2009

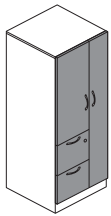

Personal Tower with Laminate Fronts, Door/File/File						
65"H x 24"W x 24"D, Wardrobe Left	HSTP652424LFFL	178	27.2	\$2294	\$2371	\$2439
65"H x 24"W x 24"D, Wardrobe Right	HSTP652424RFFL	178	27.2	\$2294	\$2371	\$2439
50"H x 24"W x 24"D, Wardrobe Left	HSTP502424LFFL	146	21.2	\$2144	\$2221	\$2289
50"H x 24"W x 24"D, Wardrobe Right	HSTP502424RFFL	146	21.2	\$2144	\$2221	\$2289
42"H x 24"W x 24"D, Wardrobe Left	HSTP422424LFFL	132	16.8	\$1833	\$1883	\$1958
42"H x 24"W x 24"D, Wardrobe Right	HSTP422424RFFL	132	16.8	\$1833	\$1883	\$1958

STORAGE

NOTES:

- Metal chassis with laminate drawer/door fronts.
- Steel frame provides durability.
- Leveling glides can be adjusted from outside or inside the case.
- Heavy-duty, telescoping ball-bearing slides.
- Baked, epoxy/polyester, powder coating finish.
- One lock secures doors and drawers.
- Pencil tray standard in top box drawer.
- One box divider standard in each box drawer.
- One crossrail standard in each file drawer.

! Locking units equipped with HON "One Key" interchangeable core removable locks. Keyed alike core model HF23S, in Satin, must be ordered separately. See page 649.

HOW TO SPECIFY

<p>Select Model Number</p> <p>H S T P 6 5 2 4 2 4 L F F L .</p>	<p>Select Base</p> <p>BX Recessed Plinth</p> <p>B X .</p>	<p>Select Pull</p> <p>A Arch PRO Silver S Square PR6 Silver</p> <p>S P R 6 .</p>	<p>Select Case Paint</p> <p>See page 640</p> <p>P 7 T .</p>	<p>Select Laminate</p> <p>See page 640</p> <p>L S A 1 .</p>	<p>Select Lock</p> <p>L Standard Lock X Omit Lock (- \$20)</p> <p>L</p>
--	--	---	--	--	--



Icon Legend on page 19

Metal Side Access Towers with Laminate Fronts

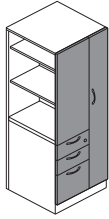

DESCRIPTION	MODEL	SHIP WEIGHT	CUBE	LIST PRICE BY PAINT GRADE		
				P1	P2	P3
Side Access Tower with Laminate Fronts, Shelves/Box/Box/File						
65”H x 24”W x 24”D, Wardrobe Left	HSTSP652424LBBFL	178	27.2	\$2484	\$2561	\$2629
65”H x 24”W x 24”D, Wardrobe Right	HSTSP652424RBBFL	178	27.2	\$2484	\$2561	\$2629
50”H x 24”W x 24”D, Wardrobe Left	HSTSP502424LBBFL	146	21.2	\$2325	\$2402	\$2470
50”H x 24”W x 24”D, Wardrobe Right	HSTSP502424RBBFL	146	21.2	\$2325	\$2402	\$2470
42”H x 24”W x 24”D, Wardrobe Left	HSTSP422424LBBFL	132	16.8	\$2097	\$2147	\$2222
42”H x 24”W x 24”D, Wardrobe Right	HSTSP422424RBBFL	132	16.8	\$2097	\$2147	\$2222

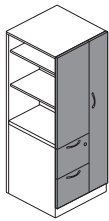

Side Access Tower with Laminate Fronts, Shelves/File/File						
65”H x 24”W x 24”D, Wardrobe Left	HSTSP652424LFFL	178	27.2	\$2434	\$2511	\$2579
65”H x 24”W x 24”D, Wardrobe Right	HSTSP652424RFFL	178	27.2	\$2434	\$2511	\$2579
50”H x 24”W x 24”D, Wardrobe Left	HSTSP502424LFFL	146	21.2	\$2275	\$2352	\$2420
50”H x 24”W x 24”D, Wardrobe Right	HSTSP502424RFFL	146	21.2	\$2275	\$2352	\$2420
42”H x 24”W x 24”D, Wardrobe Left	HSTSP422424LFFL	132	16.8	\$2047	\$2097	\$2172
42”H x 24”W x 24”D, Wardrobe Right	HSTSP422424RFFL	132	16.8	\$2047	\$2097	\$2172

STORAGE

NOTES:

- Towers can be used to support a worksurface. In order to do so, order bracket model HSTB2W1.
- Metal chassis with laminate drawer/door fronts.
- Steel frame provides durability.
- Leveling glides can be adjusted from outside or inside the case.
- Heavy-duty, telescoping ball-bearing slides.
- Baked, epoxy/polyester, powder coating finish.
- One lock secures doors and drawers.
- Pencil tray standard in top box drawer.
- One box divider standard in each box drawer.
- One crossrail standard in each file drawer.

ⓘ Locking units equipped with HON “One Key” interchangeable core removable locks. Keyed alike core model HF23S, in Satin, must be ordered separately. See page 649.

HOW TO SPECIFY

<p>Select Model Number</p> <p>H S T S P 6 5 2 4 2 4 L F F L .</p>	<p>Select Base</p> <p>BX Recessed Plinth</p> <p>B X .</p>	<p>Select Pull</p> <p>A Arch PRO Silver S Square PR6 Silver</p> <p>S P R 6 .</p>	<p>Select Case Paint</p> <p>See page 640</p> <p>P 7 T .</p>	<p>Select Laminate</p> <p>See page 640</p> <p>L S A 1 .</p>	<p>Select Lock</p> <p>L Standard Lock X Omit Lock (- \$20)</p> <p>L</p>
--	--	---	--	--	--

CONTAIN[®] Footed Metal Personal Towers

GSA SIN 33721



Icon Legend on page 19

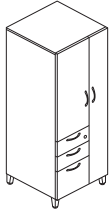

DESCRIPTION	MODEL	SHIP WEIGHT	CUBE	LIST PRICE BY CASE PAINT GRADE		
				P1	P2	P3
Footed Personal Tower with Metal Fronts, Door/Box/Box/File						
65"H x 24"W x 24"D, Wardrobe Left	HSTF652424LBBFM	178	25.8	\$2167	\$2244	\$2312
65"H x 24"W x 24"D, Wardrobe Right	HSTF652424RBBFM	178	25.8	\$2167	\$2244	\$2312
50"H x 24"W x 24"D, Wardrobe Left	HSTF502424LBBFM	146	19.8	\$2037	\$2114	\$2182
50"H x 24"W x 24"D, Wardrobe Right	HSTF502424RBBFM	146	19.8	\$2037	\$2114	\$2182
42"H x 24"W x 24"D, Wardrobe Left	HSTF422424LBBFM	132	18.2	\$1766	\$1816	\$1891
42"H x 24"W x 24"D, Wardrobe Right	HSTF422424RBBFM	132	18.2	\$1766	\$1816	\$1891

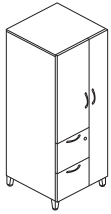

DESCRIPTION	MODEL	SHIP WEIGHT	CUBE	LIST PRICE BY CASE PAINT GRADE		
				P1	P2	P3
Footed Personal Tower with Metal Fronts, Door/File/File						
65"H x 24"W x 24"D, Wardrobe Left	HSTF652424LFFM	178	25.8	\$2117	\$2194	\$2262
65"H x 24"W x 24"D, Wardrobe Right	HSTF652424RFFM	178	25.8	\$2117	\$2194	\$2262
50"H x 24"W x 24"D, Wardrobe Left	HSTF502424LFFM	146	19.8	\$1986	\$2063	\$2131
50"H x 24"W x 24"D, Wardrobe Right	HSTF502424RFFM	146	19.8	\$1986	\$2063	\$2131
42"H x 24"W x 24"D, Wardrobe Left	HSTF422424LFFM	132	18.2	\$1716	\$1766	\$1841
42"H x 24"W x 24"D, Wardrobe Right	HSTF422424RFFM	132	18.2	\$1716	\$1766	\$1841

STORAGE

NOTES:

- Metal chassis and drawer fronts.
- Steel frame provides durability.
- Leveling glides can be adjusted from outside or inside the case.
- Heavy-duty, telescoping ball-bearing slides.
- Baked, epoxy/polyester, powder coating finish.
- One lock secures doors and drawers.
- Pencil tray standard in top box drawer.
- One box divider standard in each box drawer.
- One crossrail standard in each file drawer.

! Locking units equipped with HON "One Key" interchangeable core removable locks. Keyed alike core model HF23S, in Satin, must be ordered separately. See page 649.

HOW TO SPECIFY

Select Model Number H S T F 4 2 2 4 2 4 L B B F M .	Select Foot SF Contain Foot T1 Platinum Metallic PR6 Silver	Select Pull A Arch PRO Silver R Radius N Integral S Square PR6 Silver	Select Paint Color See page 640	Select Front Paint See page 640 NA Matches Case (+ \$0) P1 upcharge (+ \$100) P2 upcharge (+ \$120) P3 upcharge (+ \$140)	Select Lock L Standard Lock X Omit Lock (- \$20)
---	---	--	---	---	---



Icon Legend on page 19

Footed Metal Side Access Towers

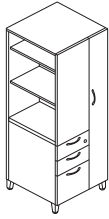

DESCRIPTION	MODEL	SHIP WEIGHT	CUBE	LIST PRICE BY CASE PAINT GRADE		
				P1	P2	P3
Footed Side Access Tower with Metal Fronts, Shelves/Box/Box/File						
65”H x 24”W x 24”D, Wardrobe Left	HSTSF652424LBBFM	178	25.8	\$2289	\$2366	\$2434
65”H x 24”W x 24”D, Wardrobe Right	HSTSF652424RBBFM	178	25.8	\$2289	\$2366	\$2434
50”H x 24”W x 24”D, Wardrobe Left	HSTSF502424LBBFM	146	19.8	\$2150	\$2227	\$2295
50”H x 24”W x 24”D, Wardrobe Right	HSTSF502424RBBFM	146	19.8	\$2150	\$2227	\$2295
42”H x 24”W x 24”D, Wardrobe Left	HSTSF422424LBBFM	132	18.2	\$1953	\$2003	\$2078
42”H x 24”W x 24”D, Wardrobe Right	HSTSF422424RBBFM	132	18.2	\$1953	\$2003	\$2078

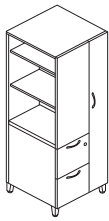

DESCRIPTION	MODEL	SHIP WEIGHT	CUBE	LIST PRICE BY CASE PAINT GRADE		
				P1	P2	P3
Footed Side Access Tower with Metal Fronts, Shelves/File/File						
65”H x 24”W x 24”D, Wardrobe Left	HSTSF652424LFFM	178	25.8	\$2238	\$2315	\$2383
65”H x 24”W x 24”D, Wardrobe Right	HSTSF652424RFFM	178	25.8	\$2238	\$2315	\$2383
50”H x 24”W x 24”D, Wardrobe Left	HSTSF502424LFFM	146	19.8	\$2099	\$2176	\$2244
50”H x 24”W x 24”D, Wardrobe Right	HSTSF502424RFFM	146	19.8	\$2099	\$2176	\$2244
42”H x 24”W x 24”D, Wardrobe Left	HSTSF422424LFFM	132	18.2	\$1902	\$1952	\$2027
42”H x 24”W x 24”D, Wardrobe Right	HSTSF422424RFFM	132	18.2	\$1902	\$1952	\$2027

NOTES:

- Towers can be used to support a worksurface. In order to do so, order bracket model HSTB2W1.
- Metal chassis and drawer fronts.
- Steel frame provides durability.
- Leveling glides can be adjusted from outside or inside the case.
- Heavy-duty, telescoping ball-bearing slides.
- Baked, epoxy/polyester, powder coating finish.
- One lock secures doors and drawers.
- Pencil tray standard in top box drawer.
- One box divider standard in each box drawer.
- One crossrail standard in each file drawer.

! Locking units equipped with HON “One Key” interchangeable core removable locks. Keyed alike core model HF23S, in Satin, must be ordered separately. See page 649.

STORAGE

HOW TO SPECIFY

Select Model Number	Select Foot	Select Pull	Select Paint Color	Select Front Paint	Select Panel Paint	Select Lock
	SF Contain Foot T1 Platinum Metallic PR6 Silver	A Arch PRO Silver R Radius N Integral S Square PR6 Silver	See page 640	See page 640 NA Matches Case (+ \$0) P1 upcharge (+ \$100) P2 upcharge (+ \$120) P3 upcharge (+ \$140)	NA Matches Case	L Standard Lock X Omit Lock (- \$20)
HSTSF422424RBBFM	SFT1	SPR6	P7T	NA	NA	L

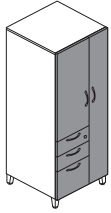

DESCRIPTION	MODEL	SHIP WEIGHT	CUBE	LIST PRICE BY PAINT GRADE		
				P1	P2	P3
Footed Personal Tower with Laminate Fronts, Door/Box/Box/File						
65"H x 24"W x 24"D, Wardrobe Left	HSTF652424LBBFL	178	25.8	\$2466	\$2543	\$2611
65"H x 24"W x 24"D, Wardrobe Right	HSTF652424RBBFL	178	25.8	\$2466	\$2543	\$2611
50"H x 24"W x 24"D, Wardrobe Left	HSTF502424LBBFL	146	19.8	\$2316	\$2393	\$2461
50"H x 24"W x 24"D, Wardrobe Right	HSTF502424RBBFL	146	19.8	\$2316	\$2393	\$2461
42"H x 24"W x 24"D, Wardrobe Left	HSTF422424LBBFL	132	18.2	\$2005	\$2055	\$2130
42"H x 24"W x 24"D, Wardrobe Right	HSTF422424RBBFL	132	18.2	\$2005	\$2055	\$2130

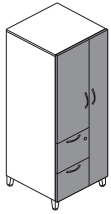

Footed Personal Tower with Laminate Fronts, Door/File/File						
65"H x 24"W x 24"D, Wardrobe Left	HSTF652424LFFL	178	25.8	\$2415	\$2492	\$2560
65"H x 24"W x 24"D, Wardrobe Right	HSTF652424RFFL	178	25.8	\$2415	\$2492	\$2560
50"H x 24"W x 24"D, Wardrobe Left	HSTF502424LFFL	146	19.8	\$2265	\$2342	\$2410
50"H x 24"W x 24"D, Wardrobe Right	HSTF502424RFFL	146	19.8	\$2265	\$2342	\$2410
42"H x 24"W x 24"D, Wardrobe Left	HSTF422424LFFL	132	18.2	\$1955	\$2005	\$2080
42"H x 24"W x 24"D, Wardrobe Right	HSTF422424RFFL	132	18.2	\$1955	\$2005	\$2080

STORAGE

NOTES:

- Metal chassis with laminate drawer/door fronts.
- Steel frame provides durability.
- Leveling glides can be adjusted from outside or inside the case.
- Heavy-duty, telescoping ball-bearing slides.
- Baked, epoxy/polyester, powder coating finish.
- One lock secures doors and drawers.
- Pencil tray standard in top box drawer.
- One box divider standard in each box drawer.
- One crossrail standard in each file drawer.

! Locking units equipped with HON "One Key" interchangeable core removable locks. Keyed alike core model HF23S, in Satin, must be ordered separately. See page 649.

HOW TO SPECIFY

Select Model Number H S T F 6 5 2 4 2 4 L B B F L .	Select Foot SF Contain Foot T1 Platinum Metallic PR6 Silver	Select Pull A Arch PRO Silver S Square PR6 Silver	Select Case Paint See page 640	Select Laminate See page 640	Select Lock L Standard Lock X Omit Lock (- \$20)
H S T F 6 5 2 4 2 4 L B B F L .	S F T 1 .	S P R 6 .	P 7 T .	L S A 1 .	L



Icon Legend on page 19

Footed Metal Side Access Towers with Laminate Fronts

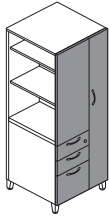

DESCRIPTION	MODEL	SHIP WEIGHT	CUBE	LIST PRICE BY PAINT GRADE		
				P1	P2	P3
Footed Side Access Tower with Laminate Fronts, Shelves/Box/Box/File						
65”H x 24”W x 24”D, Wardrobe Left	HSTSF652424LBBFL	178	25.8	\$2606	\$2683	\$2751
65”H x 24”W x 24”D, Wardrobe Right	HSTSF652424RBBFL	178	25.8	\$2606	\$2683	\$2751
50”H x 24”W x 24”D, Wardrobe Left	HSTSF502424LBBFL	146	19.8	\$2447	\$2524	\$2592
50”H x 24”W x 24”D, Wardrobe Right	HSTSF502424RBBFL	146	19.8	\$2447	\$2524	\$2592
42”H x 24”W x 24”D, Wardrobe Left	HSTSF422424LBBFL	132	18.2	\$2219	\$2269	\$2344
42”H x 24”W x 24”D, Wardrobe Right	HSTSF422424RBBFL	132	18.2	\$2219	\$2269	\$2344

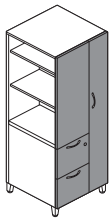

DESCRIPTION	MODEL	SHIP WEIGHT	CUBE	LIST PRICE BY PAINT GRADE		
				P1	P2	P3
Footed Side Access Tower with Laminate Fronts, Shelves/File/File						
65”H x 24”W x 24”D, Wardrobe Left	HSTSF652424LFFL	178	25.8	\$2555	\$2632	\$2700
65”H x 24”W x 24”D, Wardrobe Right	HSTSF652424RFFL	178	25.8	\$2555	\$2632	\$2700
50”H x 24”W x 24”D, Wardrobe Left	HSTSF502424LFFL	146	19.8	\$2396	\$2473	\$2541
50”H x 24”W x 24”D, Wardrobe Right	HSTSF502424RFFL	146	19.8	\$2396	\$2473	\$2541
42”H x 24”W x 24”D, Wardrobe Left	HSTSF422424LFFL	132	18.2	\$2168	\$2218	\$2293
42”H x 24”W x 24”D, Wardrobe Right	HSTSF422424RFFL	132	18.2	\$2168	\$2218	\$2293



Tower Kickplates (Field Installable)		SHIP WEIGHT	CUBE	LIST PRICE BY PAINT GRADE		
DESCRIPTION	MODEL			P1	P2	P3
For 24” Tower, Left	HSTAKL	2	0.3	\$160	\$168	\$173
For 24” Tower, Right	HSTAKR	2	0.3	\$160	\$168	\$173

Specify: Model.Paint
SPECIFYING EXAMPLE: HSATKL.P

NOTES:

- Towers can be used to support a worksurface. In order to do so, order bracket model HSTB2W1.
 - Metal chassis with laminate drawer/door fronts.
 - Steel frame provides durability.
 - Leveling glides can be adjusted from outside or inside the case.
 - Heavy-duty, telescoping ball-bearing slides.
 - Baked, epoxy/polyester, powder coating finish.
 - One lock secures doors and drawers.
 - Pencil tray standard in top box drawer.
 - One box divider standard in each box drawer.
 - One crossrail standard in each file drawer.
- ! Locking units equipped with HON “One Key” interchangeable core removable locks. Keyed alike core model HF23S, in Satin, must be ordered separately. See page 649.

HOW TO SPECIFY

<p>Select Model Number</p> <p>H S T S F 6 5 2 4 2 4 L B B F L</p>	<p>Select Foot</p> <p>SF Contain Foot T1 Platinum Metallic PR6 Silver</p> <p>S F T 1</p>	<p>Select Pull</p> <p>A Arch PRO Silver S Square PR6 Silver</p> <p>S P R 6</p>	<p>Select Case Paint</p> <p>See page 640</p> <p>P 7 T</p>	<p>Select Laminate</p> <p>See page 640</p> <p>L S A 1</p>	<p>Select Lock</p> <p>L Standard Lock X Omit Lock (- \$20)</p> <p>L</p>
--	---	--	--	--	---

CONTAIN[®] 18"W Slim Metal Personal Towers

GSA SIN 33721



Icon Legend on page 19

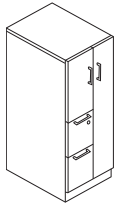

DESCRIPTION	MODEL	SHIP WEIGHT	CUBE	LIST PRICE BY CASE PAINT GRADE		
				P1	P2	P3
18"W Slim Personal Tower, Plinth w/Metal Fronts						
65"H x 18"W x 24"D, Left Hand	HSTP651824LFFM	148	19.4	\$1756	\$1833	\$1901
65"H x 18"W x 24"D, Right Hand	HSTP651824RFFM	148	19.4	\$1756	\$1833	\$1901
50"H x 18"W x 24"D, Left Hand	HSTP501824LFFM	121	16.0	\$1641	\$1718	\$1786
50"H x 18"W x 24"D, Right Hand	HSTP501824RFFM	121	16.0	\$1641	\$1718	\$1786
42"H x 18"W x 24"D, Left Hand	HSTP421824LFFM	109	13.7	\$1403	\$1453	\$1528
42"H x 18"W x 24"D, Right Hand	HSTP421824RFFM	109	13.7	\$1403	\$1453	\$1528

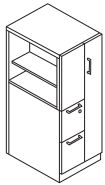

DESCRIPTION	MODEL	SHIP WEIGHT	CUBE	LIST PRICE BY CASE PAINT GRADE		
				P1	P2	P3
18"W Slim Side Access Tower, Plinth, Metal Fronts						
65"H x 18"W x 24"D, Left Hand	HSTSP651824LFFM	148	19.4	\$1862	\$1939	\$2007
65"H x 18"W x 24"D, Right Hand	HSTSP651824RFFM	148	19.4	\$1862	\$1939	\$2007
50"H x 18"W x 24"D, Left Hand	HSTSP501824LFFM	121	16.0	\$1741	\$1818	\$1886
50"H x 18"W x 24"D, Right Hand	HSTSP501824RFFM	121	16.0	\$1741	\$1818	\$1886
42"H x 18"W x 24"D, Left Hand	HSTSP421824LFFM	109	13.7	\$1567	\$1617	\$1692
42"H x 18"W x 24"D, Right Hand	HSTSP421824RFFM	109	13.7	\$1567	\$1617	\$1692

NOTES:

- Towers can be used to support a worksurface. In order to do so, order bracket model HSTB2W1.
- Metal chassis and drawer fronts.
- Steel frame provides durability.
- Leveling glides can be adjusted from outside or inside the case.
- Heavy-duty, telescoping ball-bearing slides.
- Baked, epoxy/polyester, powder coating finish.
- One lock secures doors and drawers.
- One crossrail standard in each file drawer.

! Locking units equipped with HON "One Key" interchangeable core removable locks. Keyed alike core model HF23S, in Satin, must be ordered separately. See page 649.

HOW TO SPECIFY

Select Model Number H S T P 6 5 1 8 2 4 L F F M .	Select Base BK Flush Plinth BX Recessed Plinth	Select Pull A Arch PRO Silver N Integral S Square PR6 Silver	Select Paint Color See page 640	Select Front Paint See page 640 NA Matches Case (+ \$0) P1 upcharge (+ \$100) P2 upcharge (+ \$120) P3 upcharge (+ \$140)	Select Lock L Standard Lock X Omit Lock (- \$20)
---	---	--	---	---	---

Select Model Number H S T S P 6 5 1 8 2 4 L F F M .	Select Base BK Flush Plinth BX Recessed Plinth	Select Pull A Arch PRO Silver N Integral S Square PR6 Silver	Select Case Paint See page 640	Select Front Paint See page 640 NA Matches Case (+ \$0) P1 upcharge (+ \$100) P2 upcharge (+ \$120) P3 upcharge (+ \$140)	Select Panel Paint NA Matches Case	Select Lock L Standard Lock X Omit Lock (- \$20)
---	---	--	--	---	--	---



Icon Legend on page 19

18"W Slim Metal Personal Towers

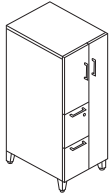

DESCRIPTION	MODEL	SHIP WEIGHT	CUBE	LIST PRICE BY CASE PAINT GRADE		
				P1	P2	P3
18"W Slim Personal Tower, Footed w/Metal Fronts						
65"H x 18"W x 24"D, Left Hand	HSTF651824LFFM	148	19.4	\$1878	\$1955	\$2023
65"H x 18"W x 24"D, Right Hand	HSTF651824RFFM	148	19.4	\$1878	\$1955	\$2023
50"H x 18"W x 24"D, Left Hand	HSTF501824LFFM	121	14.9	\$1762	\$1839	\$1907
50"H x 18"W x 24"D, Right Hand	HSTF501824RFFM	121	14.9	\$1762	\$1839	\$1907
42"H x 18"W x 24"D, Left Hand	HSTF421824LFFM	109	12.6	\$1524	\$1574	\$1649
42"H x 18"W x 24"D, Right Hand	HSTF421824RFFM	109	12.6	\$1524	\$1574	\$1649

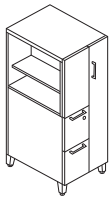

DESCRIPTION	MODEL	SHIP WEIGHT	CUBE	LIST PRICE BY CASE PAINT GRADE		
				P1	P2	P3
18"W Slim Side Access Tower, Footed w/Metal Fronts						
65"H x 18"W x 24"D, Left Hand	HSTSF651824LFFM	148	19.4	\$1984	\$2061	\$2129
65"H x 18"W x 24"D, Right Hand	HSTSF651824RFFM	148	19.4	\$1984	\$2061	\$2129
50"H x 18"W x 24"D, Left Hand	HSTSF501824LFFM	121	14.9	\$1862	\$1939	\$2007
50"H x 18"W x 24"D, Right Hand	HSTSF501824RFFM	121	14.9	\$1862	\$1939	\$2007
42"H x 18"W x 24"D, Left Hand	HSTSF421824LFFM	109	12.6	\$1688	\$1738	\$1813
42"H x 18"W x 24"D, Right Hand	HSTSF421824RFFM	109	12.6	\$1688	\$1738	\$1813

STORAGE

NOTES:

- Towers can be used to support a worksurface. In order to do so, order bracket model HSTB2W1.
- Metal chassis and drawer fronts.
- Steel frame provides durability.
- Leveling glides can be adjusted from outside or inside the case.
- Heavy-duty, telescoping ball-bearing slides.
- Baked, epoxy/polyester, powder coating finish.
- One lock secures doors and drawers.
- One crossrail standard in each file drawer.

ⓘ Locking units equipped with HON "One Key" interchangeable core removable locks. Keyed alike core model HF23S, in Satin, must be ordered separately. See page 649.

HOW TO SPECIFY

Select Model Number H S T F 6 5 1 8 2 4 L F F M .	Select Foot SF Contain Foot T1 Platinum Metallic PR6 Silver	Select Pull A Arch PRO Silver N Integral S Square PR6 Silver	Select Paint Color See page 640	Select Front Paint See page 640 NA Matches Case (+ \$0) P1 upcharge (+ \$100) P2 upcharge (+ \$120) P3 upcharge (+ \$140)	Select Lock L Standard Lock X Omit Lock (- \$20)
---	--	--	---	---	---

Select Model Number H S T S F 6 5 1 8 2 4 L F F M .	Select Foot SF Contain Foot T1 Platinum Metallic PR6 Silver	Select Pull A Arch PRO Silver N Integral S Square PR6 Silver	Select Case Paint See page 640	Select Front Paint See page 640 NA Matches Case (+ \$0) P1 upcharge (+ \$100) P2 upcharge (+ \$120) P3 upcharge (+ \$140)	Select Panel Paint NA Matches Case	Select Lock L Standard Lock X Omit Lock (- \$20)
---	--	--	--	---	--	---

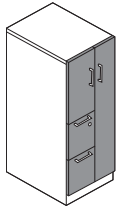

DESCRIPTION	MODEL	SHIP WEIGHT	CUBE	LIST PRICE BY PAINT GRADE		
				P1	P2	P3
18"W Slim Personal Tower, Plinth w/Laminate Fronts						
65"H x 18"W x 24"D, Left Hand	HSTP651824LFFL	148	19.4	\$2019	\$2096	\$2164
65"H x 18"W x 24"D, Right Hand	HSTP651824RFFL	148	19.4	\$2019	\$2096	\$2164
50"H x 18"W x 24"D, Left Hand	HSTP501824LFFL	121	16.0	\$1887	\$1964	\$2032
50"H x 18"W x 24"D, Right Hand	HSTP501824RFFL	121	16.0	\$1887	\$1964	\$2032
42"H x 18"W x 24"D, Left Hand	HSTP421824LFFL	109	13.7	\$1613	\$1663	\$1738
42"H x 18"W x 24"D, Right Hand	HSTP421824RFFL	109	13.7	\$1613	\$1663	\$1738

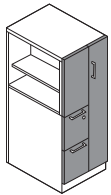

DESCRIPTION	MODEL	SHIP WEIGHT	CUBE	LIST PRICE BY PAINT GRADE		
				P1	P2	P3
18"W Slim Side Access Tower, Plinth, Laminate Fronts						
65"H x 18"W x 24"D, Left Hand	HSTSP651824LFFL	148	19.4	\$2142	\$2219	\$2287
65"H x 18"W x 24"D, Right Hand	HSTSP651824RFFL	148	19.4	\$2142	\$2219	\$2287
50"H x 18"W x 24"D, Left Hand	HSTSP501824LFFL	121	16.0	\$2001	\$2078	\$2146
50"H x 18"W x 24"D, Right Hand	HSTSP501824RFFL	121	16.0	\$2001	\$2078	\$2146
42"H x 18"W x 24"D, Left Hand	HSTSP421824LFFL	109	13.7	\$1802	\$1852	\$1927
42"H x 18"W x 24"D, Right Hand	HSTSP421824RFFL	109	13.7	\$1802	\$1852	\$1927

NOTES:

- Towers can be used to support a worksurface. In order to do so, order bracket model HSTB2W1.
- Metal chassis with laminate drawer/door fronts.
- Steel frame provides durability.
- Leveling glides can be adjusted from outside or inside the case.
- Heavy-duty, telescoping ball-bearing slides.
- Baked, epoxy/polyester, powder coating finish.
- One lock secures doors and drawers.
- One crossrail standard in each file drawer.

ⓘ Locking units equipped with HON "One Key" interchangeable core removable locks. Keyed alike core model HF23S, in Satin, must be ordered separately. See page 649.

HOW TO SPECIFY

<p>Select Model Number</p> <p>H S T S P 6 5 1 8 2 4 L F F L .</p>	<p>Select Base</p> <p>BX Recessed Plinth</p> <p>B X .</p>	<p>Select Pull</p> <p>A Arch PRO Silver S Square PR6 Silver</p> <p>S P R 6 .</p>	<p>Select Case Paint</p> <p>See page 640</p> <p>P 7 T .</p>	<p>Select Laminate</p> <p>See page 640</p> <p>L S A 1 .</p>	<p>Select Lock</p> <p>L Standard Lock X Omit Lock (- \$20)</p> <p>L</p>
--	--	---	--	--	--



Icon Legend on page 19

18"W Slim Personal Towers with Laminate Fronts

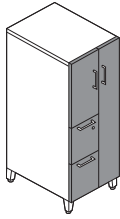

DESCRIPTION

MODEL

SHIP WEIGHT CUBE

LIST PRICE BY PAINT GRADE
P1 P2 P3

18" W Slim Personal Tower, Footed w/Laminate Fronts

65"H x 18"W x 24"D, Left Hand	HSTF651824LFFL	148	19.4	\$2141	\$2218	\$2286
65"H x 18"W x 24"D, Right Hand	HSTF651824RFFL	148	19.4	\$2141	\$2218	\$2286
50"H x 18"W x 24"D, Left Hand	HSTF501824LFFL	121	16.0	\$2008	\$2085	\$2153
50"H x 18"W x 24"D, Right Hand	HSTF501824RFFL	121	16.0	\$2008	\$2085	\$2153
42"H x 18"W x 24"D, Left Hand	HSTF421824LFFL	109	13.7	\$1735	\$1785	\$1860
42"H x 18"W x 24"D, Right Hand	HSTF421824RFFL	109	13.7	\$1735	\$1785	\$1860

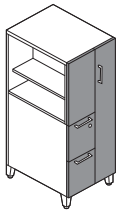

18" W Slim Side Access Tower, Footed, Laminate Fronts

65"H x 18"W x 24"D, Left Hand	HSTSF651824LFFL	148	19.4	\$2263	\$2340	\$2408
65"H x 18"W x 24"D, Right Hand	HSTSF651824RFFL	148	19.4	\$2263	\$2340	\$2408
50"H x 18"W x 24"D, Left Hand	HSTSF501824LFFL	121	14.9	\$2123	\$2200	\$2268
50"H x 18"W x 24"D, Right Hand	HSTSF501824RFFL	121	14.9	\$2123	\$2200	\$2268
42"H x 18"W x 24"D, Left Hand	HSTSF421824LFFL	109	12.6	\$1923	\$1973	\$2048
42"H x 18"W x 24"D, Right Hand	HSTSF421824RFFL	109	12.6	\$1923	\$1973	\$2048

STORAGE

NOTES:

- Towers can be used to support a worksurface. In order to do so, order bracket model HSTB2W1.
- Metal chassis with laminate drawer/door fronts.
- Steel frame provides durability.
- Leveling glides can be adjusted from outside or inside the case.
- Heavy-duty, telescoping ball-bearing slides.
- Baked, epoxy/polyester, powder coating finish.
- One lock secures doors and drawers.
- One crossrail standard in each file drawer.

ⓘ Locking units equipped with HON "One Key" interchangeable core removable locks. Keyed alike core model HF23S, in Satin, must be ordered separately. See page 649.

HOW TO SPECIFY

<p>Select Model Number</p> <p>H S T S F 6 5 1 8 2 4 L F F L .</p>	<p>Select Foot</p> <p>SF Contain Foot T1 Platinum Metallic PR6 Silver</p> <p>S F T 1 .</p>	<p>Select Pull</p> <p>A Arch PRO Silver S Square PR6 Silver</p> <p>S P R 6 .</p>	<p>Select Case Paint</p> <p>See page 640</p> <p>P 7 T .</p>	<p>Select Laminate</p> <p>See page 640</p> <p>L S A 1 .</p>	<p>Select Lock</p> <p>L Standard Lock X Omit Lock (- \$20)</p> <p>L</p>
--	---	---	--	--	--

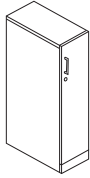

DESCRIPTION	MODEL	SHIP WEIGHT	CUBE	LIST PRICE BY CASE PAINT GRADE		
				P1	P2	P3
Wardrobe Tower, Plinth w/Metal Fronts						
65"H x 12"W x 24"D, Right Hand	HSWP651224RM	108	14.8	\$1127	\$1204	\$1272
65"H x 12"W x 24"D, Left Hand	HSWP651224LM	108	14.8	\$1127	\$1204	\$1272
50"H x 12"W x 24"D, Right Hand	HSWP501224RM	87	11.5	\$1043	\$1120	\$1188
50"H x 12"W x 24"D, Left Hand	HSWP501224LM	87	11.5	\$1043	\$1120	\$1188
42"H x 12"W x 24"D, Right Hand	HSWP421224RM	77	9.9	\$870	\$920	\$995
42"H x 12"W x 24"D, Left Hand	HSWP421224LM	77	9.9	\$870	\$920	\$995
Wardrobe Tower, Footed w/Metal Fronts						
65"H x 12"W x 18"D, Right Hand	HSWF651218RM	108	14.8	\$1034	\$1111	\$1179
65"H x 12"W x 18"D, Left Hand	HSWF651218LM	108	14.8	\$1034	\$1111	\$1179
50"H x 12"W x 18"D, Right Hand	HSWF501218RM	87	11.5	\$957	\$1034	\$1102
50"H x 12"W x 18"D, Left Hand	HSWF501218LM	87	11.5	\$957	\$1034	\$1102
42"H x 12"W x 18"D, Right Hand	HSWF421218RM	77	9.9	\$798	\$848	\$923
42"H x 12"W x 18"D, Left Hand	HSWF421218LM	77	9.9	\$798	\$848	\$923

! 18"D Wardrobes: 42"H and 50"H plinth wardrobes can be freestanding. 65"H wardrobes and/or footed wardrobes must be attached to a panel, worksurface, or ganged to another unit.

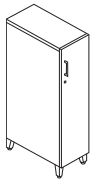

DESCRIPTION	MODEL	SHIP WEIGHT	CUBE	LIST PRICE BY CASE PAINT GRADE		
				P1	P2	P3
Wardrobe Tower, Footed w/Metal Fronts						
65"H x 12"W x 24"D, Right Hand	HSWF651224RM	108	14.1	\$1249	\$1326	\$1394
65"H x 12"W x 24"D, Left Hand	HSWF651224LM	108	14.1	\$1249	\$1326	\$1394
50"H x 12"W x 24"D, Right Hand	HSWF501224RM	87	10.8	\$1165	\$1242	\$1310
50"H x 12"W x 24"D, Left Hand	HSWF501224LM	87	10.8	\$1165	\$1242	\$1310
42"H x 12"W x 24"D, Right Hand	HSWF421224RM	77	9.1	\$992	\$1042	\$1117
42"H x 12"W x 24"D, Left Hand	HSWF421224LM	77	9.1	\$992	\$1042	\$1117
Wardrobe Tower, Footed w/Metal Fronts						
65"H x 12"W x 18"D, Right Hand	HSWF651218RM	108	11.0	\$1156	\$1233	\$1301
65"H x 12"W x 18"D, Left Hand	HSWF651218LM	108	11.0	\$1156	\$1233	\$1301
50"H x 12"W x 18"D, Right Hand	HSWF501218RM	87	8.4	\$1079	\$1156	\$1224
50"H x 12"W x 18"D, Left Hand	HSWF501218LM	87	8.4	\$1079	\$1156	\$1224
42"H x 12"W x 18"D, Right Hand	HSWF421218RM	77	7.1	\$920	\$970	\$1045
42"H x 12"W x 18"D, Left Hand	HSWF421218LM	77	7.1	\$920	\$970	\$1045

NOTES: Wardrobes come installed with a rod accessory to accept clothing hangars or a Fuse™ work tool coat hook can be added (sold separately). Wardrobes have slots cut into the inner liner that allow the user to hang Fuse™ work tool accessories inside the unit. 42"H wardrobes have 2 slots; 50"H and 65"H wardrobes have 4 slots. Wardrobes ship with one adjustable shelf. 42"H and 50"H wardrobes have 3 shelf locations; 65"H wardrobes have 6 shelf locations.

! 42"H x 18"D and 50"H x 18"D wardrobes **cannot** be freestanding. 65"H wardrobes and/or footed wardrobes must be attached to a panel, worksurface, or ganged to another unit.

HOW TO SPECIFY

Select Model Number H S W F 6 5 1 2 2 4 R M .	Select Base/Foot BK Flush Plinth Base BX Recessed Plinth Base SF Contain Foot T1 Platinum Metallic PR6 Silver	Select Pull A Arch PRO Silver R Radius N Integral S Square PR6 Silver	Select Paint Color See page 640	Select Front Paint See page 640 NA Matches Case (+ \$0) P1 upcharge (+ \$100) P2 upcharge (+ \$120) P3 upcharge (+ \$140)	Select Lock L Standard Lock X Omit Lock (- \$20)
HSWF651224RM.	SFT1.	SPR6.	PJW.	NA.	L



Icon Legend on page 19

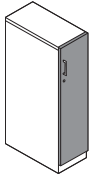

DESCRIPTION	MODEL	SHIP WEIGHT	CUBE	LIST PRICE BY PAINT GRADE		
				P1	P2	P3
Wardrobe Tower, Plinth w/Laminate Fronts						
65"H x 12"W x 24"D, Right Hand	HSWP651224RL	108	14.8	\$1296	\$1373	\$1441
65"H x 12"W x 24"D, Left Hand	HSWP651224LL	108	14.8	\$1296	\$1373	\$1441
50"H x 12"W x 24"D, Right Hand	HSWP501224RL	87	11.5	\$1200	\$1277	\$1345
50"H x 12"W x 24"D, Left Hand	HSWP501224LL	87	11.5	\$1200	\$1277	\$1345
42"H x 12"W x 24"D, Right Hand	HSWP421224RL	77	9.9	\$1001	\$1051	\$1126
42"H x 12"W x 24"D, Left Hand	HSWP421224LL	77	9.9	\$1001	\$1051	\$1126
Wardrobe Tower, Footed w/Laminate Fronts						
65"H x 12"W x 18"D, Right Hand	HSWF651218RL	108	11.6	\$1189	\$1266	\$1334
65"H x 12"W x 18"D, Left Hand	HSWF651218LL	108	11.6	\$1189	\$1266	\$1334
50"H x 12"W x 18"D, Right Hand	HSWF501218RL	87	9.0	\$1101	\$1178	\$1246
50"H x 12"W x 18"D, Left Hand	HSWF501218LL	87	9.0	\$1101	\$1178	\$1246
42"H x 12"W x 18"D, Right Hand	HSWF421218RL	77	7.7	\$918	\$968	\$1043
42"H x 12"W x 18"D, Left Hand	HSWF421218LL	77	7.7	\$918	\$968	\$1043

ⓘ 18"D Wardrobes: 42"H and 50"H plinth wardrobes can be freestanding. 65"H wardrobes and/or footed wardrobes must be attached to a panel, worksurface, or ganged to another unit.

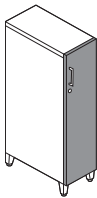

DESCRIPTION	MODEL	SHIP WEIGHT	CUBE	LIST PRICE BY PAINT GRADE		
				P1	P2	P3
Wardrobe Tower, Footed w/Laminate Fronts						
65"H x 12"W x 24"D, Right Hand	HSWF651224RL	108	14.1	\$1418	\$1495	\$1563
65"H x 12"W x 24"D, Left Hand	HSWF651224LL	108	14.1	\$1418	\$1495	\$1563
50"H x 12"W x 24"D, Right Hand	HSWF501224RL	87	10.8	\$1322	\$1399	\$1467
50"H x 12"W x 24"D, Left Hand	HSWF501224LL	87	10.8	\$1322	\$1399	\$1467
42"H x 12"W x 24"D, Right Hand	HSWF421224RL	77	9.1	\$1122	\$1172	\$1247
42"H x 12"W x 24"D, Left Hand	HSWF421224LL	77	9.1	\$1122	\$1172	\$1247
Wardrobe Tower, Footed w/Laminate Fronts						
65"H x 12"W x 18"D, Right Hand	HSWF651218RL	108	11.0	\$1311	\$1388	\$1456
65"H x 12"W x 18"D, Left Hand	HSWF651218LL	108	11.0	\$1311	\$1388	\$1456
50"H x 12"W x 18"D, Right Hand	HSWF501218RL	87	8.4	\$1223	\$1300	\$1368
50"H x 12"W x 18"D, Left Hand	HSWF501218LL	87	8.4	\$1223	\$1300	\$1368
42"H x 12"W x 18"D, Right Hand	HSWF421218RL	77	7.1	\$1039	\$1089	\$1164
42"H x 12"W x 18"D, Left Hand	HSWF421218LL	77	7.1	\$1039	\$1089	\$1164

NOTES: Wardrobes come installed with a rod accessory to accept clothing hangars or a Fuse™ work tool coat hook can be added (sold separately). Wardrobes have slots cut into the inner liner that allow the user to hang Fuse™ work tool accessories inside the unit. 42"H wardrobes have 2 slots; 50"H and 65"H wardrobes have 4 slots. Wardrobes ship with one adjustable shelf. 42"H and 50"H wardrobes have 3 shelf locations; 65"H wardrobes have 6 shelf locations.

ⓘ 42"H x 18"D and 50"H x 18"D wardrobes **cannot** be freestanding. 65"H wardrobes and/or footed wardrobes must be attached to a panel, worksurface, or ganged to another unit.

STORAGE

HOW TO SPECIFY

Select Model Number H S W F 6 5 1 2 2 4 R L .	Select Base/Foot B X Recessed Plinth Base S F Contain Foot T 1 Platinum Metallic P R 6 Silver	Select Pull A Arch P R O Silver S Square P R 6 Silver	Select Case Paint See page 640 P J W .	Select Laminate See page 640 L S A 1 .	Select Lock L Standard Lock X Omit Lock (- \$20) L
---	--	--	---	---	--

CONTAIN[®] Metal Lockers

GSA SIN 33721



Icon Legend on page 19

STORAGE

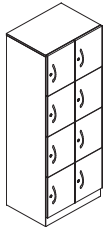

DESCRIPTION

Double Lockers, Plinth w/Metal Front
65"H x 12"W x 18"D, Right Hand, 2 Door
65"H x 12"W x 18"D, Left Hand, 2 Door
42"H x 12"W x 18"D, Right Hand, 2 Door
42"H x 12"W x 18"D, Left Hand, 2 Door

Quad Lockers, Plinth w/Metal Front
65"H x 24"W x 18"D, Right Hand, 4 Door
65"H x 24"W x 18"D, Left Hand, 4 Door
42"H x 24"W x 18"D, Right Hand, 4 Door
42"H x 24"W x 18"D, Left Hand, 4 Door

Cubby Lockers, Plinth w/Metal Front
65"H x 12"W x 18"D, Right Hand, 4 Door
65"H x 12"W x 18"D, Left Hand, 4 Door
50"H x 12"W x 18"D, Right Hand, 3 Door
50"H x 12"W x 18"D, Left Hand, 3 Door

65"H x 24"W x 18"D, Right Hand, 8 Door
65"H x 24"W x 18"D, Left Hand, 8 Door
50"H x 24"W x 18"D, Right Hand, 6 Door
50"H x 24"W x 18"D, Left Hand, 6 Door

MODEL

HSDLP651218RM
HSDLP651218LM
HSDLP421218RM
HSDLP421218LM

HSQLP652418RM
HSQLP652418LM
HSQLP422418RM
HSQLP422418LM

HSCLP651218RM
HSCLP651218LM
HSCLP501218RM
HSCLP501218LM

HSCLP652418RM
HSCLP652418LM
HSCLP502418RM
HSCLP502418LM

SHIP WEIGHT

108
108
77
77

148
148
109
109

92
92
81
81

148
148
121
121

CUBE

11.6
11.6
7.7
7.7

20.5
20.5
13.7
13.7

11.6
11.6
9.0
9.0

20.5
20.5
16.0
16.0

LIST PRICE BY CASE PAINT GRADE

P1 P2 P3

\$1244 **\$1321** **\$1389**
\$1244 **\$1321** **\$1389**
\$1130 **\$1180** **\$1255**
\$1130 **\$1180** **\$1255**

\$1863 **\$1940** **\$2008**
\$1863 **\$1940** **\$2008**
\$1491 **\$1541** **\$1616**
\$1491 **\$1541** **\$1616**

\$1264 **\$1341** **\$1409**
\$1264 **\$1341** **\$1409**
\$1072 **\$1122** **\$1247**
\$1072 **\$1122** **\$1247**

\$1975 **\$2052** **\$2120**
\$1975 **\$2052** **\$2120**
\$1570 **\$1620** **\$1695**
\$1570 **\$1620** **\$1695**

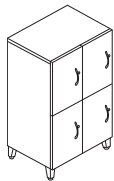
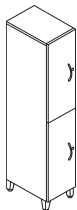

Double Lockers, Footed w/Metal Front
65"H x 12"W x 18"D, Right Hand, 2 Door
65"H x 12"W x 18"D, Left Hand, 2 Door
42"H x 12"W x 18"D, Right Hand, 2 Door
42"H x 12"W x 18"D, Left Hand, 2 Door

Quad Lockers, Footed w/Metal Front
65"H x 24"W x 18"D, Right Hand, 4 Door
65"H x 24"W x 18"D, Left Hand, 4 Door
42"H x 24"W x 18"D, Right Hand, 4 Door
42"H x 24"W x 18"D, Left Hand, 4 Door

Cubby Lockers, Footed w/Metal Front
65"H x 12"W x 18"D, Right Hand, 4 Door
65"H x 12"W x 18"D, Left Hand, 4 Door
50"H x 12"W x 18"D, Right Hand, 3 Door
50"H x 12"W x 18"D, Left Hand, 3 Door

65"H x 24"W x 18"D, Right Hand, 8 Door
65"H x 24"W x 18"D, Left Hand, 8 Door
50"H x 24"W x 18"D, Right Hand, 6 Door
50"H x 24"W x 18"D, Left Hand, 6 Door

HSDLF651218RM
HSDLF651218LM
HSDLF421218RM
HSDLF421218LM

HSQLF652418RM
HSQLF652418LM
HSQLF422418RM
HSQLF422418LM

HSCLF651218RM
HSCLF651218LM
HSCLF501218RM
HSCLF501218LM

HSCLF652418RM
HSCLF652418LM
HSCLF502418RM
HSCLF502418LM

92
92
74
74

148
148
109
109

92
92
81
81

148
148
121
121

11.0
11.0
7.1
7.1

19.4
19.4
12.6
12.6

11.0
11.0
8.4
8.4

19.4
19.4
14.9
14.9

\$1365 **\$1442** **\$1510**
\$1365 **\$1442** **\$1510**
\$1252 **\$1302** **\$1377**
\$1252 **\$1302** **\$1377**

\$1985 **\$2062** **\$2130**
\$1985 **\$2062** **\$2130**
\$1612 **\$1662** **\$1737**
\$1612 **\$1662** **\$1737**

\$1386 **\$1463** **\$1531**
\$1386 **\$1463** **\$1531**
\$1193 **\$1243** **\$1318**
\$1193 **\$1243** **\$1318**

\$2372 **\$2449** **\$2517**
\$2372 **\$2449** **\$2517**
\$2029 **\$2079** **\$2154**
\$2029 **\$2079** **\$2154**

NOTES:

- Lockers can be ganged either side-to-side or back-to-back.
- "Double" and "Quad" lockers include two double coat hooks in each compartment.
- Contain[®] Lockers can be used with Storage Islands, see page 706.

ⓘ Lockers: 42"H x 12"W and 50"H x 12"W plinth lockers can be freestanding. 65"H x 12"W plinth lockers and all heights of 12"W footed lockers must be attached to a panel, worksurface, or ganged to another unit.

HOW TO SPECIFY

Select Model Number H S Q L P 6 5 2 4 1 8 R M .	Select Base/Foot BK Flush Plinth Base BX Recessed Plinth Base SF Contain Foot T1 Platinum Metallic PR6 Silver	Select Pull A Arch PRO Silver N Integral S Square PR6 Silver	Select Paint Color See page 640	Select Front Paint See page 640 NA Matches Case (+ \$0) P1 upcharge (+ \$100) P2 upcharge (+ \$120) P3 upcharge (+ \$140)	Select Lock L Standard Lock X Omit Lock - \$40 (2 Doors) - \$60 (3 Doors) - \$80 (4 Doors) - \$120 (6 Doors) - \$160 (8 Doors)
H S Q L P 6 5 2 4 1 8 R M .	B X .	S P R 6 .	P J W .	N A .	L



Icon Legend on page 19

Metal Lockers with Laminate Fronts

STORAGE

DESCRIPTION	MODEL	SHIP WEIGHT	CUBE	LIST PRICE BY PAINT GRADE			
				P1	P2	P3	
Double Lockers, Plinth w/Laminate Front 65"H x 12"W x 18"D, Right Hand, 2 Door 65"H x 12"W x 18"D, Left Hand, 2 Door 42"H x 12"W x 18"D, Right Hand, 2 Door 42"H x 12"W x 18"D, Left Hand, 2 Door	HSDLP651218RL	108	11.6	\$1430	\$1507	\$1575	
	HSDLP651218LL	108	11.6	\$1430	\$1507	\$1575	
	HSDLP421218RL	77	7.7	\$1300	\$1350	\$1425	
	HSDLP421218LL	77	7.7	\$1300	\$1350	\$1425	
Quad Lockers, Plinth w/Laminate Front 65"H x 24"W x 18"D, Right Hand, 4 Door 65"H x 24"W x 18"D, Left Hand, 4 Door 42"H x 24"W x 18"D, Right Hand, 4 Door 42"H x 24"W x 18"D, Left Hand, 4 Door	HSQLP652418RL	148	20.5	\$2143	\$2220	\$2288	
	HSQLP652418LL	148	20.5	\$2143	\$2220	\$2288	
	HSQLP422418RL	109	13.7	\$1715	\$1765	\$1840	
	HSQLP422418LL	109	13.7	\$1715	\$1765	\$1840	
Cubby Lockers, Plinth w/Laminate Front 65"H x 12"W x 18"D, Right Hand, 4 Door 65"H x 12"W x 18"D, Left Hand, 4 Door 50"H x 12"W x 18"D, Right Hand, 3 Door 50"H x 12"W x 18"D, Left Hand, 3 Door 65"H x 24"W x 18"D, Right Hand, 8 Door 65"H x 24"W x 18"D, Left Hand, 8 Door 50"H x 24"W x 18"D, Right Hand, 6 Door 50"H x 24"W x 18"D, Left Hand, 6 Door	HSCLP651218RL	92	11.6	\$1454	\$1531	\$1599	
	HSCLP651218LL	92	11.6	\$1454	\$1531	\$1599	
	HSCLP501218RL	81	9.0	\$1233	\$1283	\$1358	
	HSCLP501218LL	81	9.0	\$1233	\$1283	\$1358	
	HSCLP652418RL	148	20.5	\$2588	\$2665	\$2733	
	HSCLP652418LL	148	20.5	\$2588	\$2665	\$2733	
	HSCLP502418RL	121	16.0	\$2194	\$2244	\$2319	
	HSCLP502418LL	121	16.0	\$2194	\$2244	\$2319	
	Double Lockers, Footed w/Laminate Front 65"H x 12"W x 18"D, Right Hand, 2 Door 65"H x 12"W x 18"D, Left Hand, 2 Door 42"H x 12"W x 18"D, Right Hand, 2 Door 42"H x 12"W x 18"D, Left Hand, 2 Door	HSDLF651218RL	92	11.0	\$1552	\$1629	\$1697
		HSDLF651218LL	92	11.0	\$1552	\$1629	\$1697
		HSDLF421218RL	74	7.1	\$1421	\$1471	\$1546
		HSDLF421218LL	74	7.1	\$1421	\$1471	\$1546
Quad Lockers, Footed w/Laminate Front 65"H x 24"W x 18"D, Right Hand, 4 Door 65"H x 24"W x 18"D, Left Hand, 4 Door 42"H x 24"W x 18"D, Right Hand, 4 Door 42"H x 24"W x 18"D, Left Hand, 4 Door	HSQLF652418RL	148	19.4	\$2264	\$2341	\$2409	
	HSQLF652418LL	148	19.4	\$2264	\$2341	\$2409	
	HSQLF422418RL	109	12.6	\$1836	\$1886	\$1961	
	HSQLF422418LL	109	12.6	\$1836	\$1886	\$1961	
Cubby Lockers, Footed w/Laminate Front 65"H x 12"W x 18"D, Right Hand, 4 Door 65"H x 12"W x 18"D, Left Hand, 4 Door 50"H x 12"W x 18"D, Right Hand, 3 Door 50"H x 12"W x 18"D, Left Hand, 3 Door 65"H x 24"W x 18"D, Right Hand, 8 Door 65"H x 24"W x 18"D, Left Hand, 8 Door 50"H x 24"W x 18"D, Right Hand, 6 Door 50"H x 24"W x 18"D, Left Hand, 6 Door	HSCLF651218RL	92	11.0	\$1576	\$1653	\$1721	
	HSCLF651218LL	92	11.0	\$1576	\$1653	\$1721	
	HSCLF501218RL	81	8.4	\$1354	\$1404	\$1479	
	HSCLF501218LL	81	8.4	\$1354	\$1404	\$1479	
	HSCLF652418RL	148	19.4	\$2710	\$2787	\$2855	
	HSCLF652418LL	148	19.4	\$2710	\$2787	\$2855	
	HSCLF502418RL	121	14.9	\$2315	\$2365	\$2440	
	HSCLF502418LL	121	14.9	\$2315	\$2365	\$2440	

NOTES:

- Lockers can be ganged either side-to-side or back-to-back.
- "Double" and "Quad" lockers include two double coat hooks in each compartment.
- Contain® Lockers can be used with Storage Islands, see page 706.
- ⓘ Lockers: 42"H x 12"W and 50"H x 12"W plinth lockers can be freestanding. 65"H x 12"W plinth lockers and all heights of 12"W footed lockers must be attached to a panel, worksurface, or ganged to another unit.

HOW TO SPECIFY

<p>Select Model Number</p> <p>H S Q L P 6 5 2 4 1 8 R L .</p>	<p>Select Base/Foot</p> <p>BX Recessed Plinth Base SF Contain Foot T1 Platinum Metallic PR6 Silver</p> <p>B X .</p>	<p>Select Pull</p> <p>A Arch PRO Silver S Square PR6 Silver</p> <p>S P R 6 .</p>	<p>Select Case Paint</p> <p>See page 640</p> <p>P J W .</p>	<p>Select Front Laminate</p> <p>See page 640</p> <p>L S A 1 .</p>	<p>Select Lock</p> <p>L Standard Lock X Omit Lock - \$40 (2 Doors) - \$60 (3 Doors) - \$80 (4 Doors) - \$120 (6 Doors) - \$160 (8 Doors)</p> <p>L</p>
--	---	--	--	--	--

CONTAIN® Metal Lockers with eLock

GSA SIN 33721



Icon Legend on page 19

STORAGE

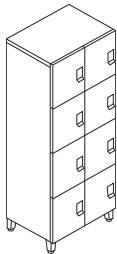
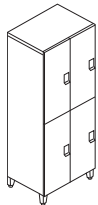
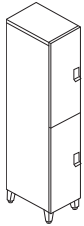
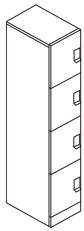
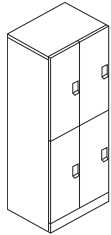
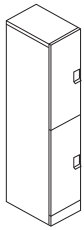

DESCRIPTION	MODEL	SHIP WEIGHT	CUBE	LIST PRICE BY CASE PAINT GRADE		
				P1	P2	P3
Double Lockers, Plinth w/Metal Front, eLock						
65"H x 12"W x 18"D, Right Hand, 2 Door	HSDLP651218RME	92	11.6	\$1801	\$1878	\$1946
65"H x 12"W x 18"D, Left Hand, 2 Door	HSDLP651218LME	92	11.6	\$1801	\$1878	\$1946
42"H x 12"W x 18"D, Right Hand, 2 Door	HSDLP421218RME	74	7.7	\$1687	\$1737	\$1812
42"H x 12"W x 18"D, Left Hand, 2 Door	HSDLP421218LME	74	7.7	\$1687	\$1737	\$1812
Quad Lockers, Plinth w/Metal Front, eLock						
65"H x 24"W x 18"D, Right Hand, 4 Door	HSQLP652418RME	148	20.5	\$2977	\$3054	\$3122
65"H x 24"W x 18"D, Left Hand, 4 Door	HSQLP652418LME	148	20.5	\$2977	\$3054	\$3122
42"H x 24"W x 18"D, Right Hand, 4 Door	HSQLP422418RME	109	13.7	\$2605	\$2655	\$2730
42"H x 24"W x 18"D, Left Hand, 4 Door	HSQLP422418LME	109	13.7	\$2605	\$2655	\$2730
Cubby Lockers, Plinth w/Metal Front, eLock						
65"H x 12"W x 18"D, Right Hand, 4 Door	HSCLP651218RME	92	11.6	\$2378	\$2455	\$2523
65"H x 12"W x 18"D, Left Hand, 4 Door	HSCLP651218LME	92	11.6	\$2378	\$2455	\$2523
50"H x 12"W x 18"D, Right Hand, 3 Door	HSCLP501218RME	81	9.0	\$1907	\$1957	\$1922
50"H x 12"W x 18"D, Left Hand, 3 Door	HSCLP501218LME	81	9.0	\$1907	\$1957	\$1922
65"H x 24"W x 18"D, Right Hand, 8 Door	HSCLP652418RME	148	20.5	\$4478	\$4555	\$4623
65"H x 24"W x 18"D, Left Hand, 8 Door	HSCLP652418LME	148	20.5	\$4478	\$4555	\$4623
50"H x 24"W x 18"D, Right Hand, 6 Door	HSCLP502418RME	121	16.0	\$3578	\$3628	\$3703
50"H x 24"W x 18"D, Left Hand, 6 Door	HSCLP502418LME	121	16.0	\$3578	\$3628	\$3703
Double Lockers, Footed w/Metal Front, eLock						
65"H x 12"W x 18"D, Right Hand, 2 Door	HSDLF651218RME	92	11.0	\$1922	\$1999	\$2067
65"H x 12"W x 18"D, Left Hand, 2 Door	HSDLF651218LME	92	11.0	\$1922	\$1999	\$2067
42"H x 12"W x 18"D, Right Hand, 2 Door	HSDLF421218RME	74	7.1	\$1809	\$1859	\$1934
42"H x 12"W x 18"D, Left Hand, 2 Door	HSDLF421218LME	74	7.1	\$1809	\$1859	\$1934
Quad Lockers, Footed w/Metal Front, eLock						
65"H x 24"W x 18"D, Right Hand, 4 Door	HSQLF652418RME	148	19.4	\$3099	\$3165	\$3244
65"H x 24"W x 18"D, Left Hand, 4 Door	HSQLF652418LME	148	19.4	\$3099	\$3176	\$3244
42"H x 24"W x 18"D, Right Hand, 4 Door	HSQLF422418RME	109	12.6	\$2726	\$2776	\$2851
42"H x 24"W x 18"D, Left Hand, 4 Door	HSQLF422418LME	109	12.6	\$2726	\$2776	\$2851
Cubby Lockers, Footed w/Metal Front, eLock						
65"H x 12"W x 18"D, Right Hand, 4 Door	HSCLF651218RME	92	11.0	\$2499	\$2576	\$2644
65"H x 12"W x 18"D, Left Hand, 4 Door	HSCLF651218LME	92	11.0	\$2499	\$2576	\$2644
50"H x 12"W x 18"D, Right Hand, 3 Door	HSCLF501218RME	81	8.4	\$2029	\$2079	\$2154
50"H x 12"W x 18"D, Left Hand, 3 Door	HSCLF501218LME	81	8.4	\$2029	\$2079	\$2154
65"H x 24"W x 18"D, Right Hand, 8 Door	HSCLF652418RME	148	20.5	\$4599	\$4676	\$4744
65"H x 24"W x 18"D, Left Hand, 8 Door	HSCLF652418LME	148	20.5	\$4599	\$4676	\$4744
50"H x 24"W x 18"D, Right Hand, 6 Door	HSCLF502418RME	121	16.0	\$3699	\$3749	\$3824
50"H x 24"W x 18"D, Left Hand, 6 Door	HSCLF502418LME	121	16.0	\$3699	\$3749	\$3824

NOTES:

- Lockers can be ganged either side-to-side or back-to-back.
- "Double" and "Quad" lockers include two double coat hooks in each compartment.
- Contain® Lockers can be used with Storage Islands, see page 706.

ⓘ Lockers: 42"H x 12"W and 50"H x 12"W plinth lockers can be freestanding. 65"H x 12"W plinth lockers and all heights of 12"W footed lockers must be attached to a panel, worksurface, or ganged to another unit.

ⓘ Every digital keypad or RFID installation site will require one Programming Key and at least one Manager Key, sold separately.

HOW TO SPECIFY

<p>Select Model Number</p> <p>H S Q L P 6 5 2 4 1 8 R M E .</p>	<p>Select Base/Foot</p> <p>BK Flush Plinth Base BX Recessed Plinth Base SF Contain Foot T1 Platinum Metallic PR6 Silver</p> <p>B X .</p>	<p>Select Pull</p> <p>E Keypad Electronic Lock D RFID Electronic Lock Pull + \$200 (2 Doors) + \$300 (3 Doors) + \$400 (4 Doors) + \$600 (6 Doors) + \$800 (8 Doors)</p> <p>D .</p>	<p>Select Paint Color</p> <p>See page 640</p> <p>P J W .</p>	<p>Select Front Paint</p> <p>See page 640 NA Matches Case (+ \$0) P1 upcharge (+ \$100) P2 upcharge (+ \$120) P3 upcharge (+ \$140)</p> <p>N A</p>
--	---	--	---	---

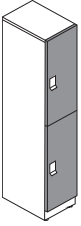
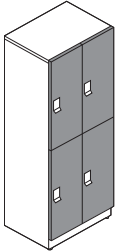
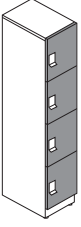
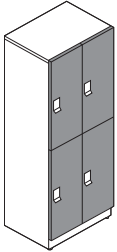
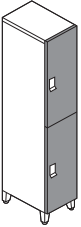
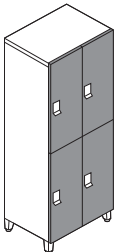
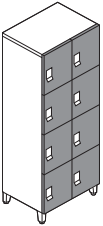
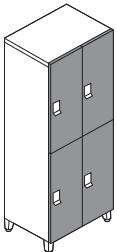

Metal Lockers with Laminate Fronts and eLock

DESCRIPTION	MODEL	SHIP WEIGHT	CUBE	LIST PRICE BY PAINT GRADE			
				P1	P2	P3	
 <p>Double Lockers, Plinth w/Laminate Front, eLock 65”H x 12”W x 18”D, Right Hand, 2 Door 65”H x 12”W x 18”D, Left Hand, 2 Door 42”H x 12”W x 18”D, Right Hand, 2 Door 42”H x 12”W x 18”D, Left Hand, 2 Door</p>	HSDLP651218RLE	92	11.6	\$1987	\$2064	\$2132	
	HSDLP651218LLE	92	11.6	\$1987	\$2064	\$2132	
	HSDLP421218RLE	74	7.7	\$1856	\$1906	\$1981	
	HSDLP421218LLE	74	7.7	\$1856	\$1906	\$1981	
 <p>Quad Lockers, Plinth w/Laminate Front, eLock 65”H x 24”W x 18”D, Right Hand, 4 Door 65”H x 24”W x 18”D, Left Hand, 4 Door 42”H x 24”W x 18”D, Right Hand, 4 Door 42”H x 24”W x 18”D, Left Hand, 4 Door</p>	HSQLP652418RLE	148	20.5	\$3257	\$3334	\$3402	
	HSQLP652418LLE	148	20.5	\$3257	\$3334	\$3402	
	HSQLP422418RLE	109	13.7	\$2828	\$2878	\$2953	
	HSQLP422418LLE	109	13.7	\$2828	\$2878	\$2953	
  <p>Cubby Lockers, Plinth w/Laminate Front, eLock 65”H x 12”W x 18”D, Right Hand, 4 Door 65”H x 12”W x 18”D, Left Hand, 4 Door 50”H x 12”W x 18”D, Right Hand, 3 Door 50”H x 12”W x 18”D, Left Hand, 3 Door</p> <p>65”H x 24”W x 18”D, Right Hand, 8 Door 65”H x 24”W x 18”D, Left Hand, 8 Door 50”H x 24”W x 18”D, Right Hand, 6 Door 50”H x 24”W x 18”D, Left Hand, 6 Door</p>	HSCLP651218RLE	92	11.6	\$2568	\$2645	\$2713	
	HSCLP651218LLE	92	11.6	\$2568	\$2645	\$2713	
	HSCLP501218RLE	81	9.0	\$2068	\$2118	\$2193	
	HSCLP501218LLE	81	9.0	\$2068	\$2118	\$2193	
	HSCLP652418RLE	148	20.5	\$4816	\$4893	\$4961	
	HSCLP652418LLE	148	20.5	\$4816	\$4893	\$4961	
	HSCLP502418RLE	121	16.0	\$3864	\$3914	\$3989	
	HSCLP502418LLE	121	16.0	\$3864	\$3914	\$3989	
	 <p>Double Lockers, Footed w/Laminate Front, eLock 65”H x 12”W x 18”D, Right Hand, 2 Door 65”H x 12”W x 18”D, Left Hand, 2 Door 42”H x 12”W x 18”D, Right Hand, 2 Door 42”H x 12”W x 18”D, Left Hand, 2 Door</p>	HSDLF651218RLE	92	11.0	\$2109	\$2186	\$2254
		HSDLF651218LLE	92	11.0	\$2109	\$2186	\$2254
		HSDLF421218RLE	74	7.1	\$1978	\$2028	\$2103
		HSDLF421218LLE	74	7.1	\$1978	\$2028	\$2103
 <p>Quad Lockers, Footed w/Laminate Front, eLock 65”H x 24”W x 18”D, Right Hand, 4 Door 65”H x 24”W x 18”D, Left Hand, 4 Door 42”H x 24”W x 18”D, Right Hand, 4 Door 42”H x 24”W x 18”D, Left Hand, 4 Door</p>	HSQLF652418RLE	148	19.4	\$3378	\$3455	\$3523	
	HSQLF652418LLE	148	19.4	\$3378	\$3455	\$3523	
	HSQLF422418RLE	109	12.6	\$2950	\$3000	\$3075	
	HSQLF422418LLE	109	12.6	\$2950	\$3000	\$3075	
  <p>Cubby Lockers, Footed w/Laminate Front, eLock 65”H x 12”W x 18”D, Right Hand, 4 Door 65”H x 12”W x 18”D, Left Hand, 4 Door 50”H x 12”W x 18”D, Right Hand, 3 Door 50”H x 12”W x 18”D, Left Hand, 3 Door</p> <p>65”H x 24”W x 18”D, Right Hand, 8 Door 65”H x 24”W x 18”D, Left Hand, 8 Door 50”H x 24”W x 18”D, Right Hand, 6 Door 50”H x 24”W x 18”D, Left Hand, 6 Door</p>	HSCLF651218RLE	92	11.0	\$2690	\$2767	\$2835	
	HSCLF651218LLE	92	11.0	\$2690	\$2767	\$2835	
	HSCLF501218RLE	81	8.4	\$2190	\$2240	\$2315	
	HSCLF501218LLE	81	8.4	\$2190	\$2240	\$2315	
	HSCLF652418RLE	148	19.4	\$4937	\$5014	\$5082	
	HSCLF652418LLE	148	19.4	\$4937	\$5014	\$5082	
	HSCLF502418RLE	121	14.9	\$3986	\$4036	\$4111	
	HSCLF502418LLE	121	14.9	\$3986	\$4036	\$4111	

STORAGE

NOTES:

- Lockers can be ganged either side-to-side or back-to-back.
- “Double” and “Quad” lockers include two double coat hooks in each compartment.
- Contain® Lockers can be used with Storage Islands, see page 706.
- ⓘ Lockers: 42”H x 12”W and 50”H x 12”W plinth lockers can be freestanding. 65”H x 12”W plinth lockers and all heights of 12”W footed lockers must be attached to a panel, worksurface, or ganged to another unit.
- ⓘ Every digital keypad or RFID installation site will require one Programming Key and at least one Manager Key, sold separately.

HOW TO SPECIFY

<p>Select Model Number</p> <p>H S Q L P 6 5 2 4 1 8 R L E .</p>	<p>Select Base/Foot</p> <p>BX Recessed Plinth Base SF Contain Foot T1 Platinum Metallic PR6 Silver</p> <p>B X .</p>	<p>Select Pull</p> <p>E Keypad Electronic Lock D RFID Electronic Lock Pull + \$200 (2 Doors) + \$300 (3 Doors) + \$400 (4 Doors) + \$600 (6 Doors) + \$800 (8 Doors)</p> <p>D .</p>	<p>Select Case Paint</p> <p>See page 640</p> <p>P J W .</p>	<p>Select Laminate</p> <p>See page 640</p> <p>L S A 1</p>
--	---	--	--	--

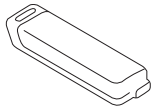

DESCRIPTION

MODEL

SHIP WEIGHT

CUBE

LIST PRICE

Digital Keys

Digilock Programming Key
Digilock Manager Key

HSLDIGPRG
HSLDIGMGR

0.8
0.8

0.0
0.0

\$162
\$127

NOTES: A Programming Key is used to initialize locks out of factory default mode and register Manager Keys to the locks. Manager Keys are used to bypass a locked unit, operating as the “master key” and it is recommended that building facilitators have at least one Manager Key. Up to 6 Manager Keys may be registered to each lock. Manager Keys provide external power to locks in case of battery failure. Programming Key is the same key as Fuse™ Digilocks and can work across both Contain® and Fuse™.

- ⓘ Only one Programming Key should be specified per installation and multiple Programming Keys are not compatible with each other.
- ⓘ Add-on digital lock orders should be programmed with the original Programming Key.

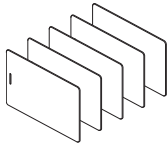

RFID Cards

Digilock RFID Cards, Pack of 5
Digilock RFID Cards, Pack of 25
Digilock RFID Cards, Pack of 100

HSLRFID5C
HSLRFID25C
HSLRFID100C

0.3
0.5
1.9

0.0
0.0
0.0

\$107
\$507
\$1924

NOTES: RFID cards are plain white and have a lanyard cutout.

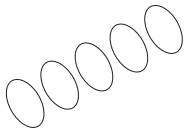

RFID Stickers

Digilock RFID Stickers, Pack of 5
Digilock RFID Stickers, Pack of 25
Digilock RFID Stickers, Pack of 100

HSLRFID5S
HSLRFID25S
HSLRFID100S

0.3
0.5
1.9

0.0
0.0
0.0

\$56
\$254
\$962

NOTES: RFID stickers are plain white, approximately 1” in diameter and may be added to the back of an existing employee badge or identification card.

STORAGE

HOW TO SPECIFY

Select
Model Number

H S L R F I D 2 5 C

CONTAIN[®] Metal Pedestals

GSA SIN 33721



Icon Legend on page 19

STORAGE

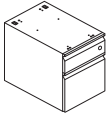
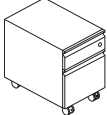
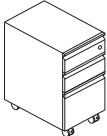
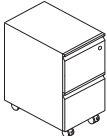
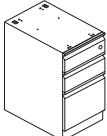
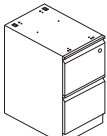
	DESCRIPTION	MODEL	SHIP WEIGHT	CUBE	LIST PRICE BY PAINT GRADE		
					P1	P2	P3
	Hanging Pedestal with Metal Fronts, Box/File						
	18"H x 15"W x 18"D	HSPH181518BFM(?)	35.8	4.4	\$566	\$594	\$622
	18"H x 15"W x 24"D	HSPH181524BFM(?)	39.3	5.7	\$603	\$631	\$659
	18"H x 15"W x 30"D	HSPH181530BFM(?)	45.6	6.4	\$637	\$665	\$693
	Mobile Pedestal with Metal Fronts, Box/File						
	21"H x 15"W x 18"D	HSPM211518BFM(?)	63.5	4.4	\$566	\$594	\$622
	21"H x 15"W x 24"D	HSPM211524BFM(?)	61.9	5.7	\$607	\$635	\$663
	Mobile Pedestal with Metal Fronts, Box/Box/File						
	27"H x 15"W x 18"D	HSPM271518BBFM(?)	63.4	5.3	\$733	\$761	\$789
	27"H x 15"W x 24"D	HSPM271524BBFM(?)	71.9	6.6	\$773	\$801	\$829
	27"H x 15"W x 30"D	HSPM271530BBFM(?)	83.6	8.2	\$814	\$842	\$870
	Mobile Pedestal with Metal Fronts, File/File						
	27"H x 15"W x 18"D	HSPM271518FFM(?)	60.9	5.3	\$733	\$761	\$789
	27"H x 15"W x 24"D	HSPM271524FFM(?)	65.7	6.6	\$773	\$801	\$829
	27"H x 15"W x 30"D	HSPM271530FFM(?)	75.2	8.2	\$814	\$842	\$870
	Plinth Support Pedestal with Metal Fronts, Box/Box/File						
	28"H x 15"W x 18"D	HSPSBX281518BBFM(?)	50.4	5.9	\$708	\$736	\$764
	28"H x 15"W x 24"D	HSPSBX281524BBFM(?)	58.6	7.5	\$748	\$776	\$804
	28"H x 15"W x 30"D	HSPSBX281530BBFM(?)	69.8	9.3	\$788	\$816	\$844
	Plinth Support Pedestal with Metal Fronts, File/File						
	28"H x 15"W x 18"D	HSPSBX281518FFM(?)	45.1	5.9	\$708	\$736	\$764
	28"H x 15"W x 24"D	HSPSBX281524FFM(?)	52.1	7.5	\$748	\$776	\$804
	28"H x 15"W x 30"D	HSPSBX281530FFM(?)	61.1	9.3	\$788	\$816	\$844

NOTES:

- Ball-bearing suspension on box and file drawer. (100%)
- Drawers color to be interior gray steel.
- See page 674 for Pedestal Seat.
- File drawer has high sides and back for filing front to back and side to side.
- Counterweight standard on all mobile peds.
- Pencil tray standard in top box drawer.
- One box divider standard in each box drawer.
- One crossrail standard in each file drawer.
- 24"D and 30"D pedestals accommodate legal files side to side.
- ! A-Pull available in Satin Chrome only.
- ! Locking units equipped with HON "One Key" interchangeable core removable locks. Keyed alike core model HF23S, in Satin, must be ordered separately. See page 649.

HOW TO SPECIFY

<p>Select Model Number</p> <p>Replace (?) with handle choice</p> <p>A Satin Chrome Arch N Full Face Integral R Full Radius</p>	<p>Select Paint Color</p> <p>See page 640</p>	<p>Select Lock Option</p> <p>L Standard Lock X Omit Lock (deduct \$20)</p>
H S P H 1 8 1 5 1 8 B F M A .	P .	L



Icon Legend on page 19

CONTAIN[®] Footed Metal Pedestals

	DESCRIPTION	MODEL	SHIP WEIGHT	CUBE	LIST PRICE BY PAINT GRADE		
					P1	P2	P3
	Footed Freestanding Pedestal with Metal Fronts, Box/File						
	22"H x 15"W x 18"D 22"H x 15"W x 24"D	HSPFSF221518BFM(?) HSPFSF221524BFM(?)	66.8 73.1	4.4 5.7	\$665 \$703	\$693 \$731	\$721 \$759
	Footed Support Pedestal with Metal Fronts, Box/Box/File						
	28"H x 15"W x 18"D 28"H x 15"W x 24"D 28"H x 15"W x 30"D	HSPSSF281518BBFM(?) HSPSSF281524BBFM(?) HSPSSF281530BBFM(?)	49.8 57.4 68.3	5.3 6.6 8.2	\$832 \$869 \$911	\$860 \$897 \$939	\$888 \$925 \$967
	Footed Support Pedestal with Metal Fronts, File/File						
	28"H x 15"W x 18"D 28"H x 15"W x 24"D 28"H x 15"W x 30"D	HSPSSF281518FFM(?) HSPSSF281524FFM(?) HSPSSF281530FFM(?)	47.3 54.3 60.0	5.3 6.6 8.2	\$832 \$869 \$911	\$860 \$897 \$939	\$888 \$925 \$967
	Flush Pedestal Kickplates (Field Installable)	HSPAK15	2.0	0.2	\$110	\$118	\$123
	Specify: Model.Paint SPECIFYING EXAMPLE: HSPAK.P						

STORAGE

NOTES:

- Ball-bearing suspension on box and file drawer. (100%)
- Drawers color to be interior gray steel.
- File drawer has high sides and back for filing front-to-back and side-to-side.
- Counterweight standard on all mobile peds.
- See page 674 for Pedestal Seat.
- Pencil tray standard in top box drawer.
- One box divider standard in each box drawer.
- One crossrail standard in each file drawer.
- 24"D and 30"D pedestals accommodate legal files side-to-side.
- ! A-Pull available in Satin Chrome only.
- ! Locking units equipped with HON "One Key" interchangeable core removable locks. Keyed alike core model HF23S, in Satin, must be ordered separately. See page 649.

HOW TO SPECIFY

<p>Select Model Number</p> <p>Replace (?) with handle choice</p> <p>A Satin Chrome Arch N Full Face Integral R Full Radius</p> <p>H S P F S F 2 2 1 5 1 8 B F M A .</p>	<p>Select Paint Color</p> <p>See page 640</p> <p>P .</p>	<p>Select Lock Option</p> <p>L Standard Lock X Omit Lock (deduct \$20)</p> <p>L .</p>	<p>Select Foot Color</p> <p>T1 Platinum Metallic PR6 Silver</p> <p>T 1</p>
---	---	--	---

CONTAIN[®] Footed Metal Pedestals

GSA SIN AS NOTED



Icon Legend on page 19

	DESCRIPTION	MODEL	SHIP WEIGHT	CUBE	LIST PRICE
SIN 33721	Counterweight — Freestanding Support Pedestals or Systems Support and Mobile Pedestals	HPCW1	18	0.1	\$201

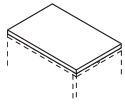

OPEN MARKET



DESCRIPTION	MODEL	SHIP WEIGHT	CUBE	FABRIC PRICE CODES			
Pedestal Seat 15"W x 22 ⁷ / ₈ "D x 2"H NOTES: For seating fabrics, see pages 22-24. SPECIFYING EXAMPLE: HPSEAT24ND.APN23	HPSEAT24ND	10	1.2	1	\$200	8	\$396
				2	\$224	9	\$427
				3	\$248	10	\$458
				4	\$272	11	\$489
				5	\$303	12	\$520
				6	\$334	L	—
				7	\$365		

STORAGE

HOW TO SPECIFY

Select Model Number	Select Fabric See pages 22-24 for seating fabric options
H P S E A T 2 4 .	A P N 2 3



Icon Legend on page 19

Metal Pedestals with Laminate Fronts

	DESCRIPTION	MODEL	SHIP WEIGHT	CUBE	LIST PRICE BY PAINT GRADE		
					P1	P2	P3
	Hanging Pedestal with Laminate Fronts, Box/File						
	18"H x 15"W x 18"D, Arch Pull	HSPH181518BFL(?)	37.6	4.4	\$724	\$752	\$780
	18"H x 15"W x 24"D, Arch Pull	HSPH181524BFL(?)	43.9	5.7	\$760	\$788	\$816
	18"H x 15"W x 30"D, Arch Pull	HSPH181530BFL(?)	53.0	6.4	\$795	\$823	\$851
	Mobile Pedestal with Laminate Fronts, Box/File						
	21"H x 15"W x 18"D, Arch Pull	HSPM211518BFL(?)	65.3	4.4	\$724	\$752	\$780
	21"H x 15"W x 24"D, Arch Pull	HSPM211524BFL(?)	63.7	5.7	\$765	\$793	\$821
	Mobile Pedestal with Laminate Fronts, Box/Box/File						
	27"H x 15"W x 18"D, Arch Pull	HSPM271518BBFL(?)	65.0	5.3	\$940	\$968	\$996
	27"H x 15"W x 24"D, Arch Pull	HSPM271524BBFL(?)	73.5	6.6	\$979	\$1007	\$1035
	27"H x 15"W x 30"D, Arch Pull	HSPM271530BBFL(?)	85.2	8.2	\$1021	\$1049	\$1077
	Mobile Pedestal with Laminate Fronts, File/File						
	27"H x 15"W x 18"D, Arch Pull	HSPM271518FFL(?)	63.4	5.3	\$940	\$968	\$996
	27"H x 15"W x 24"D, Arch Pull	HSPM271524FFL(?)	68.1	6.6	\$979	\$1007	\$1035
	27"H x 15"W x 30"D, Arch Pull	HSPM271530FFL(?)	77.6	8.2	\$1021	\$1049	\$1077
	Plinth Support Pedestal with Laminate Fronts, Box/Box/File						
	28"H x 15"W x 18"D, Arch Pull	HSPSBX281518BBFL(?)	51.7	5.9	\$916	\$944	\$972
	28"H x 15"W x 24"D, Arch Pull	HSPSBX281524BBFL(?)	59.9	7.5	\$954	\$982	\$1010
	28"H x 15"W x 30"D, Arch Pull	HSPSBX281530BBFL(?)	71.1	9.3	\$996	\$1024	\$1052
	Plinth Support Pedestal with Laminate Fronts, File/File						
	28"H x 15"W x 18"D, Arch Pull	HSPSBX281518FFL(?)	47.6	5.9	\$916	\$944	\$972
	28"H x 15"W x 24"D, Arch Pull	HSPSBX281524FFL(?)	54.6	7.5	\$954	\$982	\$1010
	28"H x 15"W x 30"D, Arch Pull	HSPSBX281530FFL(?)	63.6	9.3	\$996	\$1024	\$1052

STORAGE

NOTES:

- Ball-bearing suspension on box and file drawer. (100%)
- Drawers color to be interior gray steel.
- File drawer has high sides and back for filing front-to-back and side-to-side.
- Counterweight standard on all mobile peds.
- See page 674 for Pedestal Seat.
- Pencil tray standard in top box drawer.
- One box divider standard in each box drawer.
- One crossrail standard in each file drawer.
- 24"D and 30"D pedestals accommodate legal files side-to-side.

! Drawer Fronts available with Satin Chrome Arch only.

! Locking units equipped with HON "One Key" interchangeable core removable locks. Keyed alike core model HF23S, in Satin, must be ordered separately. See page 649.

HOW TO SPECIFY

Select Model Number Replace (?) with handle choice A Satin Chrome Arch	Select Paint Color See page 640	Select Lock Option L Standard Lock X Omit Lock (deduct \$20)	Select Laminate Option See page 640
H S P H 1 8 1 5 1 8 B F L A .	P .	L .	C

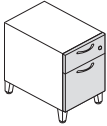
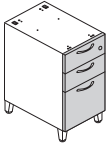
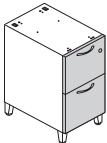

Icon Legend on page 19

	DESCRIPTION	MODEL	SHIP WEIGHT	CUBE	LIST PRICE BY PAINT GRADE		
					P1	P2	P3
	Footed Freestanding Pedestal with Laminate Fronts, Box/File						
	22"H x 15"W x 18"D, Arch Pull	HSPFSF221518BFL(?)	69.0	4.4	\$823	\$851	\$879
	22"H x 15"W x 24"D, Arch Pull	HSPFSF221524BFL(?)	75.3	5.7	\$861	\$889	\$917
	Footed Support Pedestal with Laminate Fronts, Box/Box/File						
	28"H x 15"W x 18"D, Arch Pull	HSPSSF281518BBFL(?)	51.4	5.3	\$1037	\$1065	\$1093
	28"H x 15"W x 24"D, Arch Pull	HSPSSF281524BBFL(?)	59.0	6.6	\$1077	\$1105	\$1133
	28"H x 15"W x 30"D, Arch Pull	HSPSSF281530BBFL(?)	69.9	8.2	\$1116	\$1144	\$1172
	Footed Support Pedestal with Laminate Fronts, File/File						
	28"H x 15"W x 18"D, Arch Pull	HSPSSF281518FFL(?)	49.7	5.3	\$1037	\$1065	\$1093
	28"H x 15"W x 24"D, Arch Pull	HSPSSF281524FFL(?)	56.7	6.6	\$1077	\$1105	\$1133
	28"H x 15"W x 30"D, Arch Pull	HSPSSF281530FFL(?)	62.4	8.2	\$1116	\$1144	\$1172

NOTES:

- Ball-bearing suspension on box and file drawer. (100%)
- Drawers color to be interior gray steel.
- File drawer has high sides and back for filing front-to-back and side-to-side.
- Counterweight standard on all mobile peds.
- See page 674 for Pedestal Seat.
- Pencil tray standard in top box drawer.
- One box divider standard in each box drawer.
- One crossrail standard in each file drawer.
- 24"D and 30"D pedestals accommodate legal files side-to-side.

! Drawer Fronts available with Satin Chrome Arch only.

! Locking units equipped with HON "One Key" interchangeable core removable locks. Keyed alike core model HF23S, in Satin, must be ordered separately. See page 649.

HOW TO SPECIFY

<p>Select Model Number</p> <p>Replace (?) with handle choice</p> <p>A Satin Chrome Arch</p>	<p>Select Paint Color</p> <p>See page 640</p>	<p>Select Lock Option</p> <p>L Standard Lock X Omit Lock (deduct \$20)</p>	<p>Select Laminate Option</p> <p>See page 640</p>	<p>Select Foot Color</p> <p>T1 Platinum Metallic PR6 Silver</p>
H S P F S F 2 2 1 5 1 8 B F L A .	P .	L .	C .	T 1



Footed Metal Pedestals with Laminate Fronts

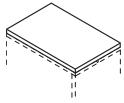

DESCRIPTION

Pedestal Seat
15"W x 22⁷/₈"D x 2"H

NOTES: For seating fabrics, see pages 22-24.
SPECIFYING EXAMPLE: HPSEAT24ND.APN23

MODEL	SHIP WEIGHT	CUBE	FABRIC PRICE CODES			
HPSEAT24ND	10	1.2	1	\$200	8	\$396
			2	\$224	9	\$427
			3	\$248	10	\$458
			4	\$272	11	\$489
			5	\$303	12	\$520
			6	\$334	L	—
			7	\$365		

NOTES:

- See Brigade[®] pedestals on page 630 for additional pedestal options. See pages 723-724 for Pedestal Accessories.

STORAGE

HOW TO SPECIFY

<p>Select Model Number</p> <p>HPSEAT24.</p>	<p>Select Fabric</p> <p>See pages 22-24 for seating fabric options</p> <p>APN23</p>
--	--

FLAGSHIP®

STORAGE



Flagship® Modular Storage.

FLAGSHIP®

Pedestals in more than 40 styles. Lateral files in 15 sizes. These are just some of the reasons why Flagship is one of HON's top metal storage collections, and why HON is America's filing and storage leader. Today's offices run on information, and Flagship helps them sort, store and share every bit of it — plus all of the personal items and daily supplies employees depend on. It's the best-built storage available from any manufacturer at any price.



FEATURES

- Rugged, high-quality construction makes HON America's leader in filing and storage.
- ColorCorrect® lets you match your Flagship storage to many office furniture manufacturers.
- Add seat cushions to mobile pedestals for short-term, stow-away guest seating.
- Modular Storage with bins for easy access and customization.
- Lateral files with storage cabinets not only corral all your info, they double as collaborative hubs.
- Squeeze more storage capacity into a smaller workstation footprint by using pedestals as worksurface supports.
- Archival filing doesn't have to be stuffy. Outfit any open space with a wall full of storage, available at a moment's notice.

FLAGSHIP® ORDERING INFORMATION

FLAGSHIP® PRODUCTS

PAINTS CODES

P1	
◆ Black	P
◆ Brownstone	P7D
◆ Charcoal	S
◆ Designer White	PJW
◆ Fossil	P28
◆ Greige	T5
◆ Light Gray	Q
◆ Loft	LOFT
◆ Muslin	T3
◆ Putty	L
◆ Shadow *	SHDW
◆ Titanium	P8T
P2	
◆ Champagne Metallic	T4
◆ Platinum Metallic	T1

OPTIONAL LAMINATE TOPS FOR LATERAL FILES

L1 LAMINATES CODES

Woodgrain	
◆ Bourbon Cherry	H
◆ Cognac	COGN
◆ Florence Walnut	LFW1
◆ Harvest	C
◆ Kingswood Walnut	LK11
◆ Mahogany	N
◆ Mocha	MOCH
◆ Natural Maple	D
◆ Pinnacle	PINC
◆ Shaker Cherry	F
◆ Sterling Ash	LSA1

Solid

◆ Charcoal	S
◆ Designer White	LDW1
◆ Loft	LOFT

Patterned

◆ Sheer Mesh*	A5
◆ Silver Mesh*	B9
◆ Steel Mesh*	A9
◆ Canyon Zephyr	K9
◆ Desert Zephyr	K8
◆ Shadow Zephyr	K1
◆ Gray*	G2
◆ White*	G1

L2 LAMINATES CODES

Woodgrain	
◆ Lowell Ash	LLA1
◆ Natural Recon	LNR1
◆ Phantom Ecrú	LPE1
◆ Portico Teak	LPT1
◆ Skyline Walnut	LSW1

PULL OPTIONS FOR CONTAIN® AND FLAGSHIP® STORAGE

Suffix "A"



Satin Chrome
Arch Pull

Suffix "N"



Full Face Integral
Drawer Pull

Suffix "R"



Full Radius
Drawer Pull

NOTES: Arch pulls available in Satin Chrome only.

* Laminate colors will have the following pre-set edgeband colors:

Laminate	Edge
Sheer Mesh	Muslin
Silver Mesh	Loft
Steel Mesh	Charcoal
Gray	Charcoal
White	Charcoal

Edgeband matches top except as noted.

For Champagne Metallic Paint, Muslin is the suggested edgeband color. When Champagne Metallic Paint is selected, pulls are standard in Muslin.

◆◆◆ For lead time information see page 19.

* De-emphasized



Icon Legend on page 19

STORAGE

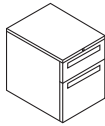
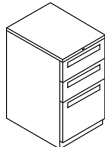
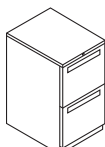
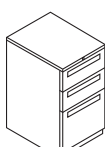
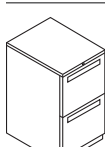
	DESCRIPTION	MODEL	SHIP WEIGHT	CUBE	LIST PRICE BY PAINT GRADE		
					P1	P2	P3
	Hanging Pedestals — Box/File						
	15"W x 16 ⁷ / ₈ "D x 19 ¹ / ₂ "H	H14917(?)	41	4.4	\$545	\$573	\$601
	15"W x 22 ⁷ / ₈ "D x 19 ¹ / ₂ "H	H14923(?)	48	6.0	\$580	\$608	\$636
	Standard Height Mobile Pedestals — Box/Box/File						
	15"W x 16 ⁷ / ₈ "D x 28"H	H18717(?)	76	5.9	\$698	\$726	\$754
	15"W x 22 ⁷ / ₈ "D x 28"H	H18723(?)	88	8.0	\$751	\$779	\$807
	15"W x 28 ⁷ / ₈ "D x 28"H	H18730(?)	102	9.8	\$806	\$834	\$862
	Standard Height Mobile Pedestals — File/File						
	15"W x 16 ⁷ / ₈ "D x 28"H	H18817(?)	72	5.9	\$692	\$720	\$748
	15"W x 22 ⁷ / ₈ "D x 28"H	H18823(?)	85	8.0	\$743	\$771	\$799
	15"W x 28 ⁷ / ₈ "D x 28"H	H18830(?)	98	9.8	\$799	\$827	\$855
	Standard Height Freestanding Support Pedestals — Box/Box/File						
	15"W x 16 ⁷ / ₈ "D x 28"H	H19717(?)	59	5.9	\$687	\$715	\$743
	15"W x 22 ⁷ / ₈ "D x 28"H	H19723(?)	73	8.0	\$739	\$767	\$795
	15"W x 28 ⁷ / ₈ "D x 28"H	H19730(?)	87	9.8	\$795	\$823	\$851
	Standard Height Freestanding Support Pedestals — File/File						
	15"W x 16 ⁷ / ₈ "D x 28"H	H19817(?)	55	5.9	\$680	\$708	\$736
	15"W x 22 ⁷ / ₈ "D x 28"H	H19823(?)	70	8.0	\$732	\$760	\$788
	15"W x 28 ⁷ / ₈ "D x 28"H	H19830(?)	83	9.8	\$787	\$815	\$843

NOTES:

- 28"H fits under all HON worksurfaces and desk shells.
- 22⁷/₈"D and 28⁷/₈"D pedestals accommodate legal files side-to-side.
- Pencil tray standard in top box drawer.
- One box divider standard in each box drawer.
- One crossrail standard in each file drawer.
- Steel ball-bearing suspension on file and box drawers.
- Full extension on all drawers.
- File drawers have high sides for filing front-to-back.
- See pages 723-724 for accessories and pedestal utilization information.
- Equipped with HON "One Key" interchangeable core removable locks.
- Hanging units are mounted using keyhole slots in top of pedestals; all hardware provided.
- Arch pull available in Satin Chrome only.
- Available in Arch (A), Full Face Integral (N) and Full Radius (R) Drawer Pulls. See page 679 for pull options.
- Choose from any of three pull options with no upcharge.
- Counterweight standard in mobile pedestals.
- Omit lock-option available. See page 746 for ordering instructions.
- See Brigade® pedestals on page 630 for additional pedestal options. See pages 723-724 for Pedestal Accessories.

! Freestanding support pedestals that are not positioned and attached under a worksurface require a counterweight kit found on page 723.

HOW TO SPECIFY

<p>Select Model Number</p> <p>A Satin Chrome Arch N Full Face Integral R Full Radius</p> <p>H 1 4 9 1 7 A</p>	<p>Select Lock Option</p> <p>L Lock (no upcharge) X Omit Lock (deduct \$20)</p> <p>L</p>	<p>Select Paint Color</p> <p>See page 679</p> <p>P</p>
---	---	--



Icon Legend on page 19

FLAGSHIP® Mobile Pedestals



HT15923N

SIN 33721

DESCRIPTION

Mobile Pedestals — Box/File
15"W x 22⁷/₈"D x 22"H

MODEL	SHIP WEIGHT	CUBE	LIST PRICE BY PAINT GRADE		
			P1	P2	P3
HT15923(?)	92	6.0	\$585	\$613	\$641

NOTES:

- Pencil tray standard in top box drawer.
- One box divider standard in each box drawer.
- One crossrail standard in each file drawer.
- File drawers have high sides for filing front-to-back.
- Steel ball-bearing suspension on file drawer, and box drawer.
- See pages 723-724 for accessories and pedestal utilization information.
- Arch pull available in Satin Chrome only.
- Choose from any of three pull options with no upcharge.
- Available in Arch (A), Full Face Integral (N) and Full Radius (R) Drawer Pulls. See page 679 for pull options.
- Equipped with HON "One Key" interchangeable core removable locks.
- Counterweight standard.
- Omit lock-option available. See page 746 for ordering instructions.

HOW TO SPECIFY

<p>Select Model Number</p> <p>A Satin Chrome Arch N Full Face Integral R Full Radius</p> <p>H 1 5 9 2 3 A .</p>	<p>Select Lock Option</p> <p>L Lock (no upcharge) X Omit Lock (deduct \$20)</p> <p>X .</p>	<p>Select Paint Color</p> <p>See page 679</p> <p>T 1</p>
--	---	---

DESCRIPTION

Pedestal Seat
15"W x 22⁷/₈"D x 2"H
NOTES: For seating fabrics, see pages 22-24.

MODEL	SHIP WEIGHT	CUBE	FABRIC PRICE CODES			
HPSEAT24ND	10 Ⓞ	1.2	1	\$200	8	\$396
			2	\$224	9	\$427
			3	\$248	10	\$458
			4	\$272	11	\$489
			5	\$303	12	\$520
			6	\$334	L	—
			7	\$365		

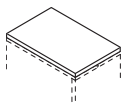

OPEN MARKET

NOTES:

- See Brigade® pedestals on page 630 for additional pedestal options. See pages 723-724 for Pedestal Accessories.

HOW TO SPECIFY

<p>Select Model Number</p> <p>H P S E A T 2 4 .</p>	<p>Select Fabric</p> <p>See pages 22-24 for seating fabric options</p> <p>A P N 2 3</p>
--	--

STORAGE

FLAGSHIP®

18" Deep Lateral Files with Drawers

GSA SIN 33721



Icon Legend on page 19

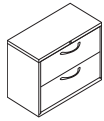

Standard Height

DESCRIPTION

Standard Height Lateral File — 2 Drawer

30"W x 18"D x 28"H
36"W x 18"D x 28"H
42"W x 18"D x 28"H

MODEL

H9170(?)
H9180(?)
H9190(?)

SHIP WEIGHT

138
156
177

CUBE

12.3
14.5
16.8

LIST PRICE BY PAINT GRADE

P1 **P2** **P3**

\$992 **\$1025** **\$1059**
\$1097 **\$1130** **\$1164**
\$1268 **\$1301** **\$1335**

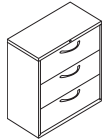

Lateral File — 3 Drawer

30"W x 18"D x 39½"H
36"W x 18"D x 39½"H
42"W x 18"D x 39½"H

H9173(?)
H9183(?)
H9193(?)

150
174
197

16.9
20.0
23.2

\$1300 **\$1333** **\$1367**
\$1459 **\$1492** **\$1526**
\$1688 **\$1721** **\$1755**

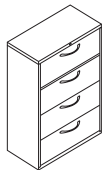

Lateral File w/o Posting Shelf — 4 Drawer

30"W x 18"D x 52½"H
36"W x 18"D x 52½"H
42"W x 18"D x 52½"H

H9174(?)
H9184(?)
H9194(?)

176
198
213

22.1
26.2
30.3

\$1637 **\$1704** **\$1770**
\$1859 **\$1926** **\$1992**
\$2133 **\$2200** **\$2266**

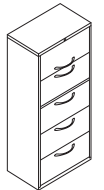

Lateral File w/o Posting Shelf — 5 Drawer

30"W x 18"D x 64¼"H
36"W x 18"D x 64¼"H
42"W x 18"D x 64¼"H

H9175(?)
H9185(?)
H9195(?)

203
238
264

26.8
31.8
36.8

\$2091 **\$2158** **\$2224**
\$2355 **\$2422** **\$2488**
\$2730 **\$2797** **\$2863**

NOTES: Top drawer is a roll-out shelf.

NOTES:

- 28"H lateral fit under standard 38000 Series and worksurfaces.
- Flush top and sides.
- Reinforced case construction.
- Lock mechanism serves both sides of drawer.
- Equipped with HON "One Key" interchangeable core removable locks.
- Counterweight included where applicable to meet ANSI/BIFMA stability requirements.
- Three-part, telescoping, steel ball-bearing suspension.
- Features drawer extension restraint; mechanical interlock inhibits the extension of more than one drawer at a time.
- Optional laminate tops and accessories — see page 720.
- Matching Pedestals — see page 680.
- Omit lock-option available. See page 746 for ordering instructions.
- Arch pull available in Satin Chrome only.
- Choose from any of three pull options with no upcharge.
- Available in Arch (A), Full Face Integral (N) and Full Radius (R) Drawer Pulls. See below and page 679 for pull options.
- See page 720 for Lateral File Accessories.
- Flagship® laterals can be used with Storage Islands, see page 706.

HOW TO SPECIFY

<p>Select Model Number</p> <p>Select the Pull</p> <p>A Satin Chrome Arch N Full Face Integral R Full Radius</p> <p>H 9 1 7 0 A</p>	<p>Select Lock Option</p> <p>L Lock (no upcharge) X Omit Lock (deduct \$20)</p> <p>L</p>	<p>Select Paint Color</p> <p>See page 679</p> <p>P</p>
--	--	--



Icon Legend on page 19

FLAGSHIP® Lateral File with Storage

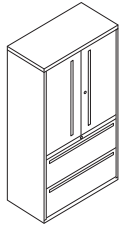

Model H9185LSN shown

DESCRIPTION

Lateral Files with Storage and Hinged Doors
36"W x 18"D x 64¼"H

MODEL

H9185LS(?)

SHIP WEIGHT

203

CUBE

31.8

LIST PRICE BY PAINT GRADE

P1 P2 P3

\$2257

\$2324

\$2390

NOTES: Lateral File drawers lock independently from storage case.

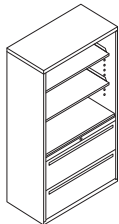

Model H9185LSNN shown

Lateral Files with Open Shelves, No Doors

36"W x 18"D x 64¼"H

H9185LSN(?)

184

31.8

\$2059

\$2126

\$2192

STORAGE

NOTES:

- 64¼"H models complement Flagship lateral file heights.
- Equipped with HON "One Key" interchangeable core removable locks. Locks on storage cabinet doors and lateral file are keyed alike.
- Three-part, telescoping, steel ball-bearing suspension.
- Includes two adjustable shelves, adjustable in 2" increments.
- Lock mechanism serves both sides of drawer.
- Features drawer extension restraint; mechanical interlock inhibits the extension of more than one drawer at a time.
- Wire management grommet in back of unit.
- Omit lock-option available. See page 746 for ordering instructions.
- Flush top and sides.
- Choose from any of three pull options with no upcharge.
- Arch pull available in Satin Chrome only.
- Available in Arch (A), Full Face Integral (N) and Full Radius (R) Drawer Pulls. See page 679 for pull options.

HOW TO SPECIFY

<p>Select Model Number</p> <p>Select the Pull</p> <p>A Satin Chrome Arch N Full Face Integral R Full Radius</p> <p>H 9 1 8 5 L S A</p>	<p>Select Lock Option</p> <p>L Lock (no upcharge) X Omit Lock (deduct \$40 for models H91756LS and H9185LS) (deduct \$20 for models H9175LSN and H9185LSN)</p> <p>X</p>	<p>Select Paint Color</p> <p>See page 679</p> <p>P</p>
--	---	--

FLAGSHIP® Modular Storage

GSA SIN 33721



Icon Legend on page 19

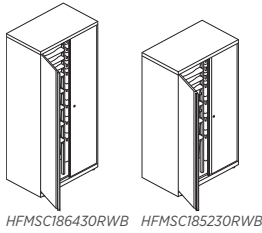

HFMSC186430RWB HFMSC185230RWB

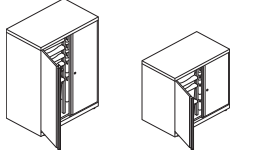

HFMSC183930RWB HFMSC182830RWB

DESCRIPTION

Modular Storage Cabinet

- 18"D x 28"H x 30"W
- 18"D x 39½"H x 30"W
- 18"D x 52½"H x 30"W
- 18"D x 64¼"H x 30"W

MODEL	SHIP WEIGHT	CUBE	LIST PRICE BY PAINT GRADE		
			P1	P2	P3
HFMSC182830RWB	119	12.0	\$1059	\$1092	\$1126
HFMSC183930RWB	138	16.2	\$1283	\$1316	\$1350
HFMSC185230RWB	176	22.4	\$1549	\$1616	\$1682
HFMSC186430RWB	184	28.2	\$1806	\$1873	\$1939

STORAGE

NOTES:

- Shipped fully assembled.
- Pre-configured trays and rails are included, see chart below.
- Additional Tray Kits may be purchased separately.
- Full radius handle on both doors.
- Four adjustable leveling glides standard.
- Reinforced top and base.
- Equipped with HON "One Key" interchangeable core removable locks standard.
- Doors have vertical stiffener standard.
- Positive door stops.
- Meets or exceeds ANSI/BIFMA and ISTA standards.
- Certified SCS Indoor Advantage Gold.

Pre-Configured Cabinets/Tray Kits

64" High Cabinet		52" High Cabinet		39" High Cabinet		28" High Cabinet	
1	2	1	2	1	2	1	2
3	4	3	4	3	4	3	4
5	6	5	6	5	6	5	6
7	8	7	8	7	8	7	8
1	2	1	2	1	2	1	2
3	4	3	4	3	4	3	4
5	6	5	6	5	6	5	6
7	8	7	8	7	8	7	8
1	2	1	2	1	2	1	2
						3	4

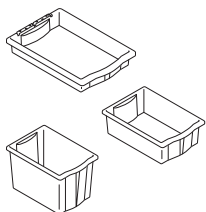

DESCRIPTION

Accessories — Tray Kit

- 3"H, 2 bins and 4 rails
- 6"H, 2 bins and 4 rails
- 12"H, 2 bins and 4 rails

NOTES: Modular Storage Cabinets come with rails and bins. Additional bins and rails may be ordered in sets of 2. Availability and usage are outlined below.

MODEL	SHIP WEIGHT	CUBE	LIST PRICE
HFMBIN3	7 Ⓞ	4.0	\$52
HFMBIN6	10 Ⓞ	4.5	\$64
HFMBIN12	12 Ⓞ	5.0	\$75

NOTES:

- Tray height options include: 3", 6", 12".
- Trays may only be used in 12" width single column/section only.
- All trays are suspended off a pair of storage rails, trays slide easily in and out and are removable.
- Trays and storage rails are field installed and may be easily reconfigured.
- Front and rear handles are integrated for easy handling/transport.
- Translucent material provides visibility to contents.

HOW TO SPECIFY

Select Model Number HFMSC186430RWB	Select Lock Option L Lock (no upcharge) X Omit Lock (deduct \$20) See page 746 for omit lock ordering instructions	Select Glide G Glide	Select Paint Color See page 679
H F M S C 1 8 6 4 3 0 R W B .	L .	G .	L D W 1

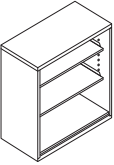
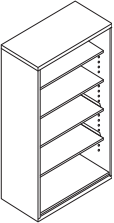

	DESCRIPTION	MODEL	SHIP WEIGHT	CUBE	LIST PRICE BY PAINT GRADE		
					P1	P2	P3
	3 Shelf 36"W x 18"D x 39½"H	HFSC183640W	100	20.0	\$876	\$943	\$1009
	5 Shelf 36"W x 18"D x 64¼"H NOTES: 64¼"H models complement Flagship lateral file heights.	HFSC183664W	148	31.8	\$1298	\$1365	\$1431

NOTES:

- Flush top and sides.
- Reinforced case construction.
- Shelves adjust in 2" increments.
- Wire management grommet in back of unit.

STORAGE

HOW TO SPECIFY

<p>Select Model Number</p> <p>H F S C 1 8 3 6 4 0 W . P</p>	<p>Select Paint Color</p> <p>See page 679</p>
---	---

FLAGSHIP® Storage Cabinets

GSA SIN 33721



Icon Legend on page 19

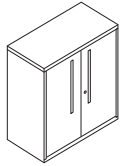

Model HFSC183640N shown

DESCRIPTION

Storage Cabinets
36"W x 18"D x 39¹/₈"H (with lock)
2 adjustable shelves

MODEL

HFSC183640(?)

SHIP WEIGHT

119

CUBE

20.0

LIST PRICE BY PAINT GRADE

P1

\$1085

P2

\$1152

P3

\$1218

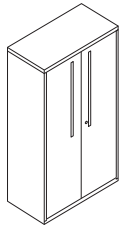

Model HFSC183664N shown

36"W x 18"D x 64¹/₄"H (with lock)
4 adjustable shelves

HFSC183664(?)

184

31.8

\$1581

\$1648

\$1714

NOTES: 64¹/₄"H models complement Flagship lateral file heights.

STORAGE

NOTES:

- Flush top and sides.
- Reinforced case construction.
- Includes adjustable shelves, adjustable in 2" increments.
- Arch pull available in Satin Chrome only.
- Choose from any of three pull options with no upcharge.
- Available in Arch (A), Full Face Integral (N) and Full Radius (R) Drawer Pulls. See below and page 679 for pull options.
- Four adjustable leveling glides are standard.
- Equipped with HON "One Key" interchangeable core removable locks.
- Wire management grommet in back of unit.
- Omit lock-option available. See page 746 for ordering instructions.

HOW TO SPECIFY

Select Model Number

Select the Pull

- A** Satin Chrome Arch
- N** Full Face Integral
- R** Full Radius

H F S C 1 8 3 6 4 0 A .

Select Lock Option

- L** Lock (no upcharge)
- X** Omit Lock (deduct \$20)

L .

Select Paint Color

See page 679

P

FLAMESAFE™ ORDERING INFORMATION

FLAMESAFE™ PRODUCTS

PAINTS CODES

P1

- ◆ Black P
- ◆ Light Gray Q
- ◆ Putty L

STORAGE

◆◆◆ For lead time information see page 19.

FLAMESAFE™ Fire-Resistant Files

OPEN MARKET



Icon Legend on page 19



DESCRIPTION

Vertical File — 2-Drawer, Letter
17³/₄"W x 25"D x 27³/₄"H

MODEL SHIP WEIGHT CUBE LIST PRICE

H52 320 10.0 \$3623

Vertical File — 2-Drawer, Legal
20³/₄"W x 25"D x 27³/₄"H

H52C 341 13.0 \$3715

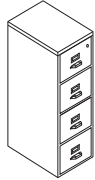

Vertical File — 4-Drawer, Letter
17³/₄"W x 25"D x 52³/₄"H

H54 546 17.0 \$5577

Vertical File — 4-Drawer, Legal
20³/₄"W x 25"D x 52³/₄"H

H54C 596 21.0 \$5694

NOTES:

- Full suspension.
- Non-asbestos.
- Follower block standard (spring-loaded).
- Chrome drawer pulls, thumb latch and label holder.
- Rated: Filing Device Class 350, 1700° for one hour with drop test.
- UL listed.
- High drawer sides.
- Available in Putty, Black and Gray only; see page 687.
- Insulated in drawer face and between drawers.
- **Full Lifetime Warranty.**

! Lock is NOT core removable.

HOW TO SPECIFY

Select Model Number <input type="text" value="H52"/>	Select Lock Option <input type="text" value="P"/>	Select Paint Color See page 687 <input type="text" value="P"/>
--	---	---

DESCRIPTION MODEL SHIP WEIGHT CUBE LIST PRICE



Lateral File — 2-Drawer
31¹/₈"W x 22¹/₈"D x 27³/₄"H

H32 436 11.0 \$5335



Lateral File — 4-Drawer
31¹/₈"W x 22¹/₈"D x 52³/₄"H

H34 723 26.0 \$8051

NOTES: Lateral Drawer inside dimensions: 25³/₈"W x 15¹/₈"D x 10³/₈"H

NOTES:

- Telescoping suspension.
- Non-asbestos.
- Available in Putty, Black and Gray only; see page 687.
- Rated: Filing Device Class 350, 1700° for one hour with drop test.
- Insulated in drawer face and between drawers.
- UL listed.
- 4 hangrails per opening, standard.
- Black, plastic recessed drawer pulls.
- **Full Lifetime Warranty.**

! Lock is NOT core removable.

HOW TO SPECIFY

Select Model Number <input type="text" value="H32"/>	Select Lock Option <input type="text" value="P"/>	Select Paint Color P Black Q Light Gray L Putty <input type="text" value="P"/>
--	---	---



Fuse™ Mobile Pedestal shown with Solve® Seating and Empower®.

FUSE™

Who says storage has to be boring? With a completely modern take on form and function, not to mention an ultra-cool color palette, Fuse storage adds personality to any home office or corporate workspace. With personal storage space for just about everything, Fuse keeps you organized even in small spaces.



FEATURES

- Designed to make the most of the compressed footprint of desking, benching and height-adjustable workstations.
- Extra thick, low profile case provides increased strength and durability while providing a modern 360-degree aesthetic for your stowage needs.
- Extended height drawers give you the extra capacity to neatly store what matters most to you.
- Add a pop of color with an optional two-tone design to give new meaning to personal space.
- Alcove for stowing backpack, purse, bag, or other personal items.
- Rear casters swivel and front casters are fixed for easier mobility.
- Casters are designed to clear the top of Coordinate™ feet.
- File drawer has high sides to allow front-to-back filing for 15" wide models.
- Side-to-side filing uses file bars for support for 10" wide models.
- Standard core removable locks make rekeying a breeze.
- Electronic keypad lock option allows for ease of locking and unlocking personal items with your Fuse™ unit.

FUSE™ ORDERING INFORMATION

FUSE™ PRODUCTS

PAINTS CODES

P1

- ◆ Black P
- ◆ Brownstone P7D
- ◆ Designer White PJW
- ◆ Charcoal P02
- ◆ Fossil*** P28
- ◆ Greige T5
- ◆ Loft LOFT
- ◆ Muslin T3
- ◆ Titanium P8T

P2*

- ◆ Champagne Metallic T4
- ◆ Silver PR6
- ◆ Solar Black P8X

P3**

- ◆ Atom P8S
- ◆ Blossom*** P8K
- ◆ Bullseye PJF
- ◆ Cabernet*** P7T
- ◆ Conifer*** P8H
- ◆ Ember P8P
- ◆ Ion P8N
- ◆ Iris P8J
- ◆ Krypton P8F
- ◆ Regatta P8M
- ◆ Succulent*** P8A

PULLS

- ◆ Square Silver SPR6
- ◆ Linear Silver LPR6
- ◆ Linear Black LP

WORKPLACE TOOLS

- ◆ Designer White DW

STORAGE

PULL OPTIONS FOR FUSE™ STORAGE



Square

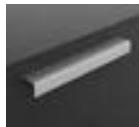

Linear

*P2 upcharges \$18 for each dot option selected.

**P3 upcharges \$40 for each dot option selected.

***TREND COLORS: These colors are intended to be an inspirational option for the trending market. Product application is limited and color availability is approximately two years to coincide with evolving workplace trends.

- The HON Company has elected to discontinue the HON Choice paint program, as of 12/31/2018, and roll it into our standard specials process.
- A special request will need to be submitted to receive pricing and order information.

◆◆◆ For lead time information see page 19.

Fuse Pedestal Functionality with Workplace Tools

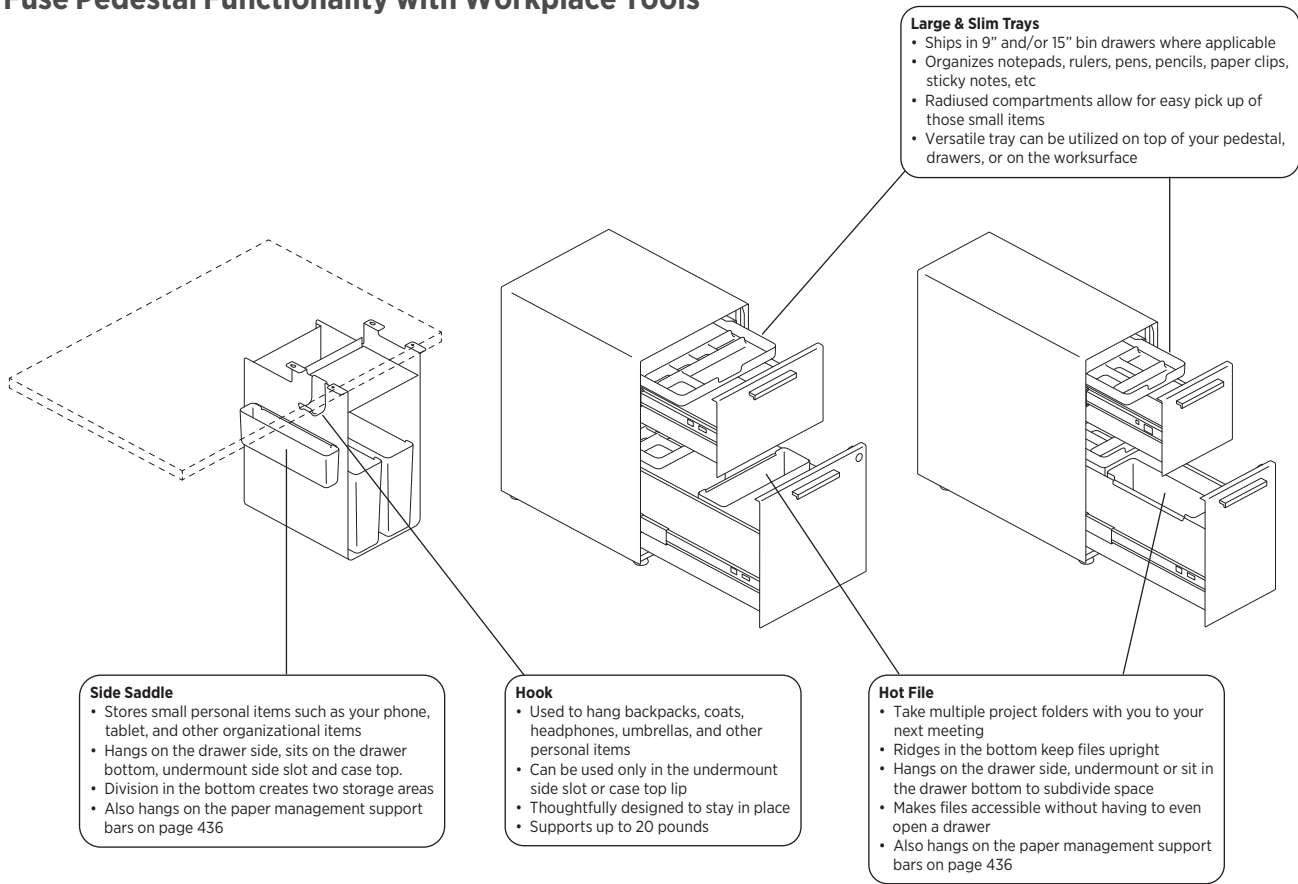

Configuration Options - Fuse

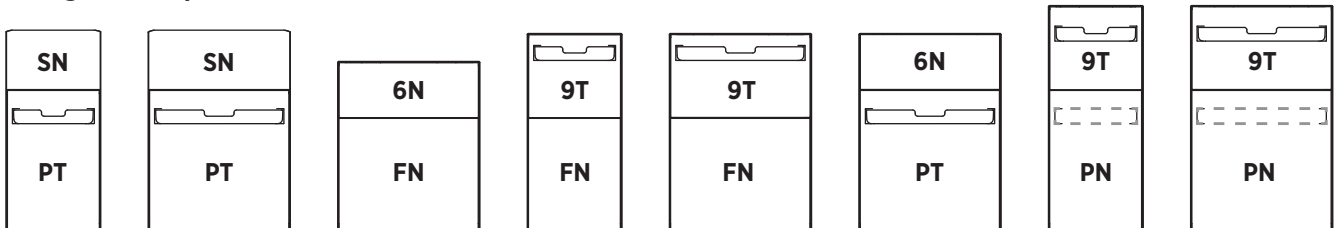

Legend

- 6N = 6" Box No Tray
- 9T = 9" Box Bin with Tray
- SN = Alcove
- FN = 12" File No Tray
- PN = 15" File No Tray
- PT = 15" Bin with Tray

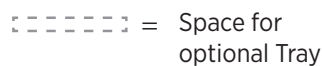
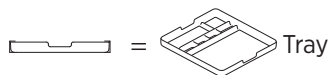

FUSE™ DIGITAL LOCK SPECIFICATIONS

Digital Keypad Lock Specification Information for Fuse™ Pedestals

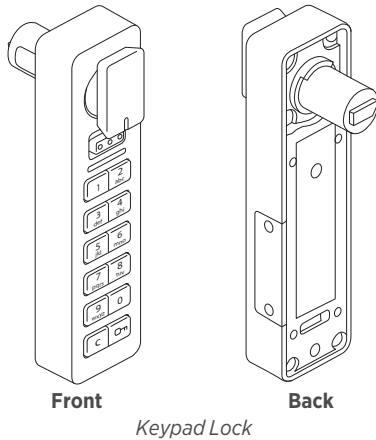

Keypad Lock

The digital keypad lock option helps modernize the workspace by eliminating the need to carry physical keys. The digital lock feature provides an alternative to standard lock and key, allowing users to simply input a code to unlock their Fuse™ storage unit. The digital keypad also supports shared applications where workstations or storage units support multiple users. These locks ship in “shared mode” by default; shared mode indicates that the lock will “forget” the paired 4-digit code after the lock is opened, allowing the unit to be used by multiple users.

❗ Order at least one Programming Key and Manager Key per install.

Digital Keypad Locks:

- Offered on all Fuse™ pedestal and undermount models.
- Ship factory installed.
- Offered in a brushed nickel finish.
- Digital keypad lock requires input of a user-selected 4-digit code.
- Digital keypad locks are powered using 2 premium lithium CR2032 batteries.
- Battery life is dependent on the frequency of operation but can last up to 5-7 years.
- **Every digital keypad installation site will require one Programming Key and at least one Manager Key, sold separately.**

Programming Key

- A Programming Key is a device used to initialize locks out of factory default mode and register Manager Keys to the locks.
- Only one Programming Key should be specified per installation site because multiple Programming Keys are not compatible with each other.
- Add-on digital lock orders should be programmed with the original Programming Key.
- Programming Key is the same key as Contain® Digilocks and can work across both Contain® and Fuse™.

Manager Key

- A Manager Key is used to bypass a locked unit; this operates as the “master key” and it is recommended that building facilitators have at least one Manager Key.
- Up to 6 Manager Keys may be registered to each lock.
- Manager Keys provide external power to locks in case of battery failure.

Digital Lock Keys and Accessories		
Description	Model	List Price
Programming Key	HSLDIGPRG	\$160
Manager Key	HSLDIGMGR	\$125



Icon Legend on page 19

FUSE™ Mobile Pedestals

	DESCRIPTION	MODEL	SHIP WEIGHT	CUBE	LIST PRICE
	Mobile Pedestal, 6" Box/12" File 15"W x 19"D x 20 3/8"H	HAPMAP196NFN	48	5.0	\$619
	15"W x 23"D x 20 3/8"H NOTES: No tray, Specification of tray color not required.	HAPMAP236NFN	54	5.9	\$664
	Mobile Pedestal, 9" Bin with Tray/12" File 15"W x 19"D x 23 3/8"H	HAPMBP199TFN	53	5.7	\$697
	15"W x 23"D x 23 3/8"H	HAPMBP239TFN	58	6.7	\$746
	Mobile Pedestal, 6" Box/15" Bin with Tray 15"W x 19"D x 23 3/8"H	HAPMBP196NPT	53	5.7	\$697
	15"W x 23"D x 23 3/8"H	HAPMBP236NPT	58	6.7	\$746
	Mobile Pedestal, 9" Bin with Tray/15" Bin 15"W x 19"D x 26 3/8"H	HAPMCP199TPN	58	6.4	\$751
	15"W x 23"D x 26 3/8"H	HAPMCP239TPN	62	7.5	\$799
	Mobile Pedestal, Alcove/15" File with Tray 15"W x 19"D x 21 1/2"H NOTES: Top matches drawer color.	HAPMBP19SNPT	58	5.7	\$649
	Slim Mobile Pedestal, 9" Bin with Tray/12" File 10"W x 23"D x 23 3/8"H	HAPMBS239TFN	47	4.9	\$710
	Slim Mobile Pedestal, 9" Bin with Tray/15" Bin 10"W x 23"D x 26 3/8"H	HAPMCS239TPN	52	5.4	\$764
	Slim Mobile Pedestal, Alcove/15" Bin with Tray 10"W x 23"D x 21 1/2"H NOTES: Top matches drawer color.	HAPMBS23SNPT	43	4.9	\$661

STORAGE

HOW TO SPECIFY

Select Model Number H A P M A P 1 9 6 N F N	Select Pull Option SPR6 SPR6 Square Silver LPR6 Linear Silver LP Linear Black	Select Case Color See page 690 P2 upcharge (+ \$18) P3 upcharge (+ \$40)	Select Drawer Color See page 690 P2 upcharge (+ \$18) P3 upcharge (+ \$40)	Select Tray Color DW Designer White	Select Lock Option L Standard Lock X Omit Lock (deduct \$20)
---	--	--	--	---	---

FUSE™ Mobile Pedestals with eLock

OPEN MARKET



Icon Legend on page 19

STORAGE

	DESCRIPTION	MODEL	SHIP WEIGHT	CUBE	LIST PRICE
	Mobile Pedestal, 6" Box/12" File, eLock 15"W x 19"D x 20 3/8"H	HAPMAP196NFNE	48	5.0	\$842
	15"W x 23"D x 20 3/8"H NOTES: No tray, Specification of tray color not required.	HAPMAP236NFNE	54	5.9	\$885
	Mobile Pedestal, 9" Box/12" File, eLock 15"W x 19"D x 23 3/8"H	HAPMBP199TFNE	53	5.7	\$917
	15"W x 23"D x 23 3/8"H	HAPMBP239TFNE	58	6.7	\$963
	Mobile Pedestal, 6" Box/15" File, eLock 15"W x 19"D x 23 3/8"H	HAPMBP196NPTE	53	5.7	\$917
	15"W x 23"D x 23 3/8"H	HAPMBP236NPTE	58	6.7	\$963
	Mobile Pedestal, 9" Box/15" File, eLock 15"W x 19"D x 26 3/8"H	HAPMCP199TPNE	58	6.4	\$968
	15"W x 23"D x 26 3/8"H	HAPMCP239TPNE	62	7.5	\$1014
	Mobile Pedestal, Alcove/15" File, eLock 15"W x 19"D x 21 1/2"H NOTES: Top matches drawer color.	HAPMBP19SNPTE	45	5.7	\$870
	Slim Mobile Pedestal, 9" Box/12" File, eLock 10"W x 23"D x 23 3/8"H	HAPMBS239TFNE	47	4.9	\$928
	Slim Mobile Pedestal, 9" Box/15" File, eLock 10"W x 23"D x 26 3/8"H	HAPMCS239TPNE	52	5.4	\$980
	Slim Mobile Pedestal, Alcove/15" File, eLock 10"W x 23"D x 21 1/2"H NOTES: Top matches drawer color.	HAPMBS23SNPTE	43	4.9	\$882

NOTES:

ⓘ Every installation will require one Programming Key and at least one Manager Key.

HOW TO SPECIFY

Select Model Number	Select Pull Option	Select Case Color	Select Drawer Color	Select Tray Color	Select Lock Option
SPR6	SPR6 Square Silver LPR6 Linear Silver LP Linear Black	See page 690 P2 upcharge (+ \$18) P3 upcharge (+ \$40)	See page 690 P2 upcharge (+ \$18) P3 upcharge (+ \$40)	DW Designer White	EBNL eLock Brushed Nickel
HAPMAP196NFNE	SPR6	P	S	DW	EBNL



Icon Legend on page 19

Freestanding Pedestals

	DESCRIPTION	MODEL	SHIP WEIGHT	CUBE	LIST PRICE
	Freestanding Pedestal, 9" Bin with Tray/12" File				
	15"W x 19"D x 21"H	HAPGBP199TFN	53	5.7	\$678
	15"W x 23"D x 21"H	HAPGBP239TFN	58	5.7	\$724
	Freestanding Pedestal, 6" Box/15" Bin with Tray				
	15"W x 19"D x 21"H	HAPGBP196NPT	53	5.7	\$678
	15"W x 23"D x 21"H	HAPGBP236NPT	58	5.7	\$724
	Freestanding Pedestal, 9" Bin with Tray/15" Bin				
	15"W x 19"D x 24"H	HAPGCP199TPN	58	5.7	\$729
	15"W x 23"D x 24"H	HAPGCP239TPN	62	5.7	\$776
	Freestanding Pedestal, Alcove/15" Bin with Tray				
	15"W x 19"D x 21"H	HAPGBP19SNPT	45	5.7	\$630
	NOTES: Top matches drawer color.				
	Slim Freestanding Pedestal, 9" Bin with Tray/12" File				
	10"W x 23"D x 21"H	HAPGBS239TFN	47	5.7	\$689
	Slim Freestanding Pedestal, 9" Bin with Tray/15" Bin				
	10"W x 23"D x 24"H	HAPGCS239TPN	52	5.4	\$741
	Slim Freestanding Pedestal, Alcove/15" Bin with Tray				
	10"W x 23"D x 21"H	HAPGBS23SNPT	43	4.9	\$642
	NOTES: Top matches drawer color.				

STORAGE

HOW TO SPECIFY

<p>Select Model Number</p> <p>H A P G B P 1 9 9 T F N .</p>	<p>Select Pull Option</p> <p>SPR6 Square Silver LPR6 Linear Silver LP Linear Black</p> <p>S P R 6 .</p>	<p>Select Case Color</p> <p>See page 690 P2 upcharge (+ \$18) P3 upcharge (+ \$40)</p> <p>P .</p>	<p>Select Drawer Color</p> <p>See page 690 P2 upcharge (+ \$18) P3 upcharge (+ \$40)</p> <p>S .</p>	<p>Select Tray Color</p> <p>DW Designer White</p> <p>D W .</p>	<p>Select Lock Option</p> <p>L Standard Lock X Omit Lock (deduct \$20)</p> <p>L</p>
--	--	--	--	---	--

FUSE™ Freestanding Pedestals with eLock

OPEN MARKET



Icon Legend on page 19

STORAGE

	DESCRIPTION	MODEL	SHIP WEIGHT	CUBE	LIST PRICE
	Freestanding Pedestal, 9" Box/12" File, eLock				
	15"W x 19"D x 21"H 15"W x 23"D x 21"H	HAPGBP199TFNE HAPGBP239TFNE	53 58	5.7 6.7	\$898 \$942
	Freestanding Pedestal, 6" Box/15" File, eLock				
	15"W x 19"D x 21"H 15"W x 23"D x 21"H	HAPGBP196NPTE HAPGBP236NPTE	53 58	5.7 6.7	\$898 \$942
	Freestanding Pedestal, 9" Box/15" File, eLock				
	15"W x 19"D x 24"H 15"W x 23"D x 24"H	HAPGCP199TPNE HAPGCP239TPNE	58 62	6.4 7.5	\$947 \$992
	Freestanding Pedestal, Alcove/15" File, eLock				
	15"W x 19"D x 21"H NOTES: Top matches drawer color.	HAPGBP19SNPTE	45	5.7	\$852
	Slim Freestanding Pedestal, 9" Box/12" File, eLock				
	10"W x 23"D x 24"H	HAPGBS239TFNE	47	4.9	\$909
	Slim Freestanding Pedestal, 9" Box/15" File, eLock				
	10"W x 23"D x 24"H	HAPGCS239TPNE	52	5.4	\$958
	Slim Freestanding Pedestal, Alcove/15" File				
	10"W x 23"D x 24"H NOTES: Top matches drawer color.	HAPGBS23SNPTE	43	4.9	\$863

NOTES:

ⓘ Every installation will require one Programming Key and at least one Manager Key.

HOW TO SPECIFY

Select Model Number	Select Pull Option	Select Case Color	Select Drawer Color	Select Tray Color	Select Lock Option
	SPR6 Square Silver LPR6 Linear Silver LP Linear Black	See page 690 P2 upcharge (+ \$18) P3 upcharge (+ \$40)	See page 690 P2 upcharge (+ \$18) P3 upcharge (+ \$40)	DW Designer White	EBNL eLock Brushed Nickel
H A P G B P 1 9 9 T F N E .	S P R 6 .	P .	S .	D W .	E B N L



FUSE™ Pedestal Cushion

	DESCRIPTION	MODEL	SHIP WEIGHT	CUBE	FABRIC PRICE CODES			
	Seat Cushion For 19"D Pedestal	HAESC19	6	1.0	1	\$192	8	\$330
					2	\$216	9	\$348
					3	\$240	10	\$366
					4	\$258	11	\$384
					5	\$276	12	\$402
					6	\$294	L	—
					7	\$312		
	Seat Cushion For 23"D Pedestal	HPSEAT24ND	10	1.2	1	\$200	8	\$396
					2	\$224	9	\$427
					3	\$248	10	\$458
					4	\$272	11	\$489
					5	\$303	12	\$520
					6	\$334	L	—
					7	\$365		

STORAGE

HOW TO SPECIFY

<p>Select Model Number</p> <p>HAESC19</p>	<p>Select Fabric</p> <p>See pages 22-24 for seating fabric options</p> <p>CU10</p>
--	---

FUSE™ Undermount Storage

OPEN MARKET



Icon Legend on page 19

STORAGE

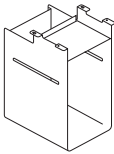
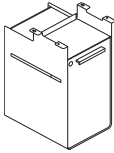
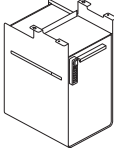
	DESCRIPTION	MODEL	SHIP WEIGHT	CUBE	LIST PRICE
	Undermount Storage Cubby NOTES: No need to specify door color or lock option.	HAUFO15N	19	3.3	\$373
	Undermount Storage Cubby with Locking Door Right-Hinged Left-Hinged NOTES: Right-Hinged shown.	HAUFHR15N HAUFHL15N	24 24	3.3 3.3	\$442 \$442
	Undermount Storage Cubby with Locking Door, eLock Right-Hinged Left-Hinged ! Every installation will require one Programming Key and at least one Manager Key.	HAUFHR15NE HAUFHL15NE	24 24	3.3 3.3	\$676 \$676

NOTES:

- Compatible with all HON benching, desking, and height adjustable tables, except where required space is unavailable.
- Ensure weight limit of height adjustable table system is considered before adding undermount storage.
- Open and hinged door units contain a side slot on each side which can be used to hang Workplace Tools.
- Can accommodate two Hot Files, HAEHF, side-by-side.
- 42 lb. storage capacity based on BIFMA loading standards.

! Workplace Tools trays will not fit in cubby.

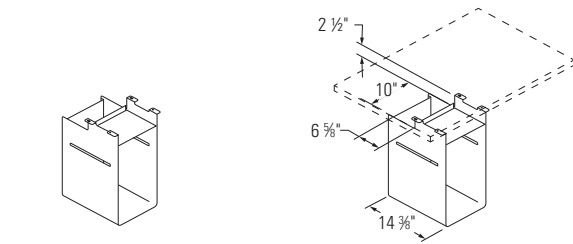

HAUFO15N
Undermount Open Cubby

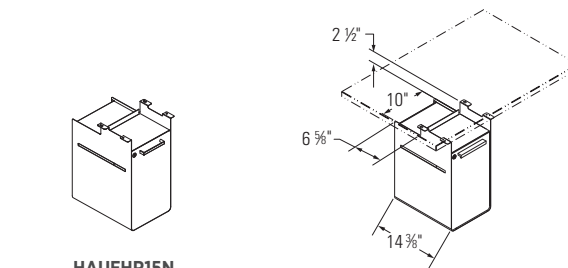



HAUFHR15N
Undermount Storage Cubby
with Locking Door

HOW TO SPECIFY

<p>Select Model Number</p> <p>HAUFO15N .</p>	<p>Select Case Color</p> <p>See page 690 P2 upcharge (+ \$18) P3 upcharge (+ \$40)</p> <p>P .</p>	<p>Select Door Color</p> <p>See page 690 P2 upcharge (+ \$18) P3 upcharge (+ \$40)</p> <p>S .</p>	<p>Select Lock Option</p> <p>L Standard Lock X Omit Lock (deduct \$20) EBNL Digital Lock Brushed Nickel (Specify for eLock models only)</p> <p>L</p>
---	--	--	---

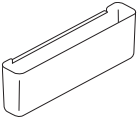

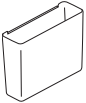
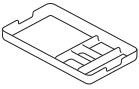
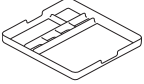

	DESCRIPTION	MODEL	SHIP WEIGHT	CUBE	LIST PRICE
	Side Saddle 12¼"W x 2½"D x 4"H	HAESS	0.6	0.1	\$39
	Hook 1⅝"W x 2¼"D x 3¼"H	HAECBH	0.1	0.1	\$26
	Hot File 12¼"W x 3⅞"D x 9½"H	HAEHF	0.7	1.5	\$58
	Slim Tray 8½"W x 14⅞"D x 1½"H	HAEST	1.0	0.2	\$51
	Large Tray 13½"W x 14⅞"D x 1½"H	HAELT	1.5	0.2	\$58

STORAGE

NOTES:

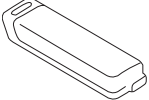
- Side Saddle and Hot File work on Paper Management Support Bars on page 436.
- Hook weight limit 20 lbs.

	DESCRIPTION	MODEL	SHIP WEIGHT	CUBE	LIST PRICE
	Digital Keys Digilock Programming Key	HSLDIGPRG	0.8 	0.0	\$162
	Digilock Manager Key	HSLDIGMGR	0.8 	0.0	\$127
	<p>NOTES: A Programming Key is used to initialize locks out of factory default mode and register Manager Keys to the locks. Manager Keys are used to bypass a locked unit, operating as the "master key" and it is recommended that building facilitators have at least one Manager Key. Up to 6 Manager Keys may be registered to each lock. Manager Keys provide external power to locks in case of battery failure. Programming Key is the same key as Contain® Digilocks and can work across both Contain® and Fuse™.</p> <ul style="list-style-type: none"> ! Only one Programming Key should be specified per installation and multiple Programming Keys are not compatible with each other. ! Add-on digital lock orders should be programmed with the original Programming Key. ! Digital lock user guides and manager programming instructions included. 				

HOW TO SPECIFY

Select Model Number	Select Color
HAESS .	DW Designer White
<input type="checkbox"/> H <input type="checkbox"/> A <input type="checkbox"/> E <input type="checkbox"/> S <input type="checkbox"/> S .	<input type="checkbox"/> D <input type="checkbox"/> W

STORAGE ISLANDS

STORAGE



Storage Islands shown with Contain® Cubby Lockers, Preside® Table, and Cliq™ Seating.

STORAGE ISLANDS

Time to pack your bags and take flight for an organizational oasis. Storage Islands don't just offer intuitive design and unsurpassed efficiency, they create flexible work suites that will make any project feel like a vacation. Whether you're a creative collaborator or intensely focused on a singular project, these dynamic units are easily customizable with a variety of vibrant color options and offer seamless adaptability to meet the demands of any work day.



FEATURES

- Storage Islands promotes dual-purpose spaces, where functional storage and impromptu collaboration occur simultaneously.
- Clean, straightforward design complements and blends in with any workspace.
- Combine metal, laminate, and color to create a unique and unified look for your office.
- Storage Islands works best with Contain® lockers, wardrobes, and Flagship® and Brigade® laterals.
- **Will work with 3-high Flagship® and Brigade® laterals, bookcases, and storage cabinets along with Contain® 42½" lockers and wardrobes.**
- Add Storage Islands to existing HON Storage banks or specify in new office configurations.
- Pair storage options to consolidate storage away from the workspace, allowing more room for people to interact, work, and move freely.

STORAGE ISLANDS ORDERING INFORMATION

WORKSURFACES

L1 LAMINATES CODES

Woodgrain

◆ Bourbon Cherry	H
◆ Cognac	COGN
◆ Florence Walnut	LFW1
◆ Harvest	C
◆ Kingswood Walnut	LK11
◆ Mahogany	N
◆ Mocha	MOCH
◆ Natural Maple	D
◆ Pinnacle	PINC
◆ Shaker Cherry	F
◆ Sterling Ash	LSA1

Solid

◆ Black	P
◆ Charcoal	S
◆ Designer White	LDW1
◆ Loft	LOFT

L2 LAMINATES CODES

Woodgrain

◆ Lowell Ash	LLA1
◆ Natural Recon	LNR1
◆ Phantom Ecreu	LPE1
◆ Portico Teak	LPT1
◆ Skyline Walnut	LSW1

WORKSURFACE EDGE BAND

Woodgrain

◆ Bourbon Cherry	H
◆ Cognac	COGN
◆ Florence Walnut	FW
◆ Harvest	C
◆ Kingswood Walnut	KI
◆ Lowell Ash	DL
◆ Mahogany	N
◆ Mocha	MOCH
◆ Natural Maple	D
◆ Natural Recon	NR
◆ Phantom Ecreu	PE
◆ Pinnacle	PINC
◆ Portico Teak	DP
◆ Shaker Cherry	F
◆ Skyline Walnut	SW
◆ Sterling Ash	SA

Solid

◆ Black	P
◆ Charcoal	S
◆ Designer White	DW
◆ Loft	LOFT

O-LEGS

PAINTS CODES

P1

◆ Black	P
◆ Brownstone	P7D
◆ Charcoal	S
◆ Designer White	PJW
◆ Fossil	P28
◆ Greige	T5
◆ Loft	LOFT
◆ Muslin	T3
◆ Shadow [Ⓢ]	SHDW
◆ Titanium	P8T

P2

◆ Champagne Metallic	T4
◆ Platinum Metallic	T1
◆ Silver	PR6
◆ Solar Black	P8X

P3

◆ Atom	P8S
◆ Blossom*	P8K
◆ Bullseye	PJF
◆ Cabernet*	P7T
◆ Conifer*	P8H
◆ Ember	P8P
◆ Ion	P8N
◆ Iris	P8J
◆ Krypton	P8F
◆ Regatta	P8M
◆ Succulent*	P8A

* TREND COLORS: These colors are intended to be an inspirational option for the trending market. Product application is limited and color availability is approximately two years to coincide with evolving workplace trends.

◆◆◆ For lead time information see page 19.

STORAGE ISLANDS SPECIFYING GUIDE

Top

Available in single depth (18") or double depth (36") surface.

- Select dimensionality based on configuration and the number of undersurface units being spanned.

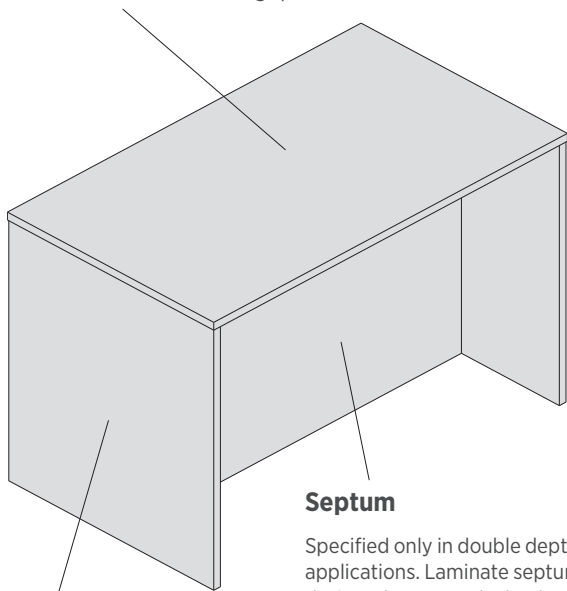

End Panel

Specified in both 18"D and 36"D applications to conceal the sides of storage units.

Septum

Specified only in double depth (36") applications. Laminate septum designed to cover the back of storage units and create a clean countertop application. Septum must be connected to end panels or an adjacent septum.

Back

Specified only in 18"D configurations to conceal the back of storage units.

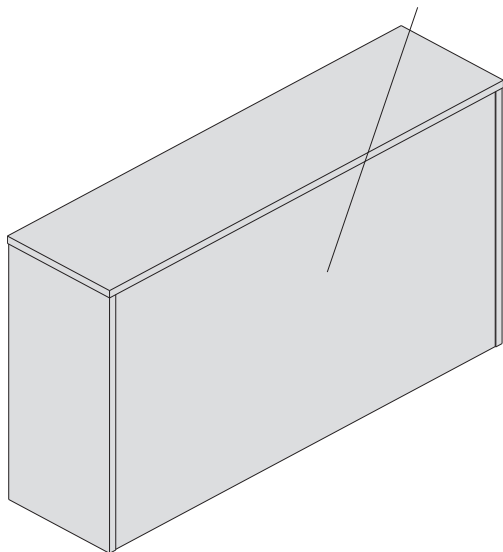

Specifying Islands Top

1. Select top depth.
 - Single (18") or double (36")
2. Select desired Islands configuration.
 - Top only
 - Top + End Panels
 - Top + End Panels + Back or Septum
3. Determine top width.
 - Identify the number of side-to-side storage units the top will cover. This number represents the number of **spans**.

* Note: Front-to-back units do not factor into number of spans. **Although top or end panels accept a septum, it is not required to add septum based on application.**

Specifying End Panels, Back, or Septum

4. Identify storage units Islands will wrap. This determines correct height.
 - Contain® Height = 40⁴/₈"
 - Flagship®/Brigade® Height = 38⁴/₈"
5. Specify additional components to complete your Islands configuration.
 - End panels, back, or septum
 - **The width and number of units spanned on the septum must match the width and number of units spanned on the top.**

Peninsula Applications

Specify an O-Leg or laminate return panel to create an open span collaboration space.

* Note: Under-surface storage must support at least one side of the open span.

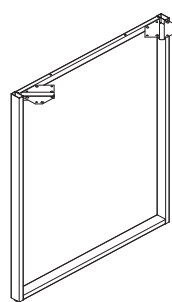

O-Leg

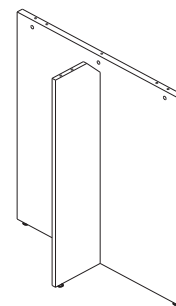

Return Panel

O-Leg & Return Panel

Specified to support open span top in Islands peninsula configuration.

STORAGE ISLANDS SPECIFYING GUIDE

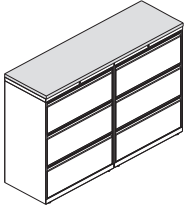

18"D - Single Depth

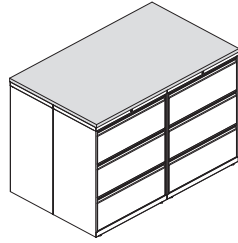

36"D - Double Depth

Light Configuration

Top Only
See page 707 to specify top only.

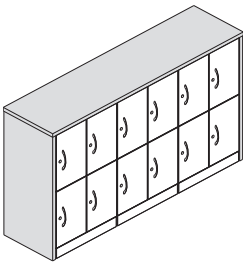

18"D - Single Depth

Medium Configuration

Top + 2 End Panels
See page 708 to specify top designed for end panel configuration.

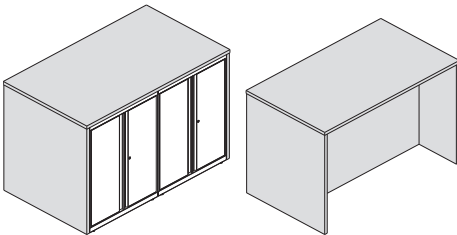

36"D - Double Depth

Heavy Configuration

Top + 2 End Panels + Back (18"D)
Top + 2 End Panels + Septum (36"D)

See page 709 to specify top designed for end panel and back/septum configuration.

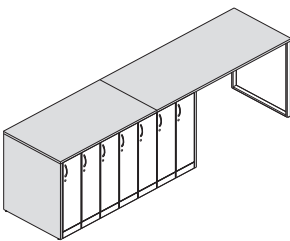

Joined Configuration

Top + 1 End Panel + Septum (36"D)

See page 710 to specify top designed for single end panel and septum configuration.

⚠ This application is designed to join worksurfaces to create a run greater than 84".

NOTES: End panels, backs, septums, and support legs specified separately from tops. See pages 711-712 for specification options.

STORAGE ISLANDS

Planning Typicals

QTY	DESCRIPTION	MODEL	LIST PRICE	PRICE EXTENSION
1	Islands Top, Double Depth, Span 2 36"D x 60"W	HSISLAUTNPB6036S2	\$534	\$534
4	Brigade® Lateral File, 3 Drawer 30"W x 18"D x 39 1/8"H	H873	\$1,147	\$4,588
TOTAL:				\$5,122

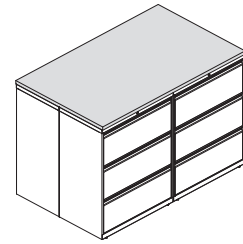

STORAGE

QTY	DESCRIPTION	MODEL	LIST PRICE	PRICE EXTENSION
1	Islands Top for Use w/2 End Panels and Back, Span 3 18"D x 72"W	HSISLAUT2PYB7218S3	\$413	\$413
1	Islands End Panels, Contain® Height, Back, Left 42"H x 18"W	HSISLACEYB1842L	\$198	\$198
1	Islands End Panels, Contain® Height, Back, Right 42"H x 18"W	HSISLACEYB1842R	\$198	\$198
1	Islands Back, Contain® Height, 2 End Panels, Span 3 42"H x 72"W	HSISLACB2P7242S3	\$428	\$428
3	Contain® Quad Locker, Plinth Base 42"H x 24"W x 18"D	HSQLP422418RM	\$1,491	\$4,473
TOTAL:				\$5,710

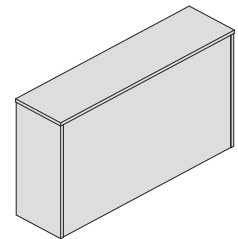
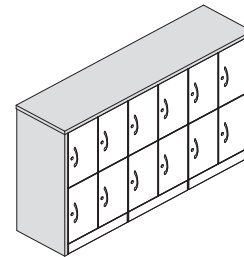

QTY	DESCRIPTION	MODEL	LIST PRICE	PRICE EXTENSION
1	Islands Top for Use w/2 End Panels & Septum, Span 2 36"D x 60"W	HSISLAUT1PYB6036S2	\$614	\$614
2	Islands End Panel, Flagship® Height, Septum 42"H x 36"W	HSISLAFEYB3642	\$347	\$694
1	Islands Septum, Flagship® Height, 2 End Panels, Span 2 42"H x 60"W	HSISLAFB2P6042S2	\$365	\$365
2	Flagship® Modular Storage Cabinet 39 1/8"H x 30"W x 18"D	HFMSC183930RWB	\$1,283	\$2,566
TOTAL:				\$4,239

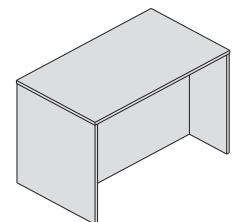
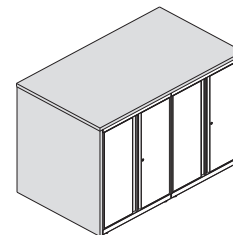

STORAGE ISLANDS

Planning Typical

QTY	DESCRIPTION	MODEL	LIST PRICE	PRICE EXTENSION
1	Islands Top for Use w/2 End Panels and Septum, Span 2 36"D x 84"W	HSISLAUT2PYB8436S2	\$746	\$746
2	Islands End Panel, Flagship® Height, Back 42"H x 36"W	HSISLAFESP3642	\$347	\$694
2	Flagship® Bookcase, 3-Shelves 39½"H x 30"W x 18"D	HFSC183640W	\$876	\$1,752
TOTAL:			\$3,192	

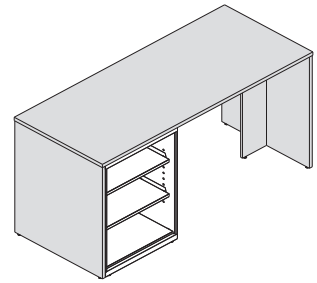

QTY	DESCRIPTION	MODEL	LIST PRICE	PRICE EXTENSION
2	Islands Top for Use w/1 End Panel & Septum, Span 2 36"D x 60"W	HSISLAUT1PYB6036S2	\$614	\$1,228
2	Islands Septum, Flagship® Height, 2 End Panels, Span 2 42"H x 60"W	HSISLAFB2P6042S2	\$365	\$730
2	Islands End Panel, Flagship® Height, Septum 42"H x 36"W	HSISLAFEYB3642	\$347	\$694
4	Flagship® Lateral File, 3 Drawer 39½"H x 30"W x 18"D	H9173(?)	\$1,300	\$5,200
1	Flat Bracket 18"D	HHN831118	\$64	\$64
TOTAL:			\$7,916	

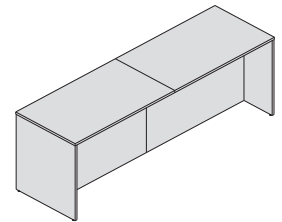
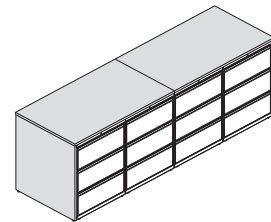

STORAGE

QTY	DESCRIPTION	MODEL	LIST PRICE	PRICE EXTENSION
1	Islands Top, 1 End Panel and Septum, Span 5 36"D x 60"W	HSISLAUT1PYB6036S5	\$614	\$614
2	Islands End Panel, Contain® Height, Back, No Septum 42"H x 36"W	HSISLACEYB3642	\$347	\$694
1	Islands Top, 1 End Panel and Septum, Span 2 36"D x 84"W	HSISLAUT1PYB8436S2	\$714	\$714
1	Islands O-Leg, Contain® Height 42"H x 36"W	HSISLACO3642	\$500	\$500
2	External Stiffener Channel 48"W, for 60" Worksurface	HLSLZ5SC60	\$98	\$196
14	Contain® Wardrobe, Plinth Base 42"H x 12"W x 18"D	HSWP421224RM	\$870	\$12,180
TOTAL:			\$14,898	

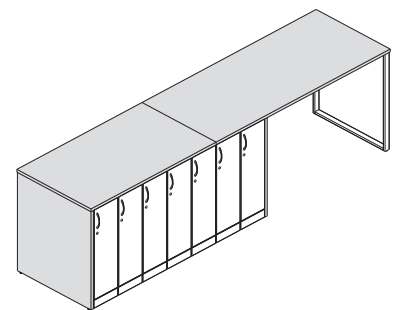

! On joined application, top seam only allowed when supported by storage underneath seam.

STORAGE ISLANDS SPECIFYING GUIDE

WORKING WITH STORAGE ISLANDS WITH CONTAIN® OR FLAGSHIP®/BRIGADE® PRODUCT LINES

Storage Islands come in 2" height variances designed to be used with Contain® or Flagship®/Brigade® product lines. Worksurfaces and end supports are made of 1¼" particleboard with 2mm edgeband and laminate on both sides of all surfaces. Center septums are made of ¾" particleboard with 0.5mm edgeband and laminate on both sides.

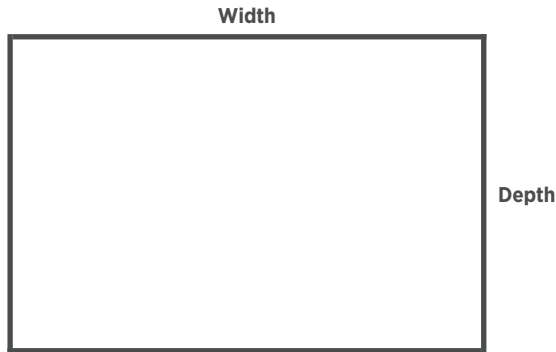

	Depths
18"D No Back, No End Panels	18.19
18"D No Back, With End Panels	18.44
18"D Back and End Panels	19.455
36"D No Back, No End Panels	36.69
36"D End Panels	

End Panel Sizes		
	Depths	Height
18"D No Back, Contain®	18.19	40.8
18"D No Back, Flagship®		38.8
18"D With Back, Contain®	19.20	40.8
18"D With Back, Flagship®		38.8
36"D End Panels, Contain®	36.44	40.8
36"D End Panels, Flagship®		38.8

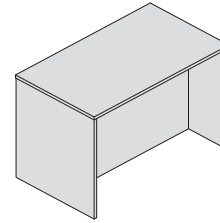

Countertop Application

- When specifying a countertop application, the end of a septum cannot be left open. The septum must connect to an end panel or adjacent septum.

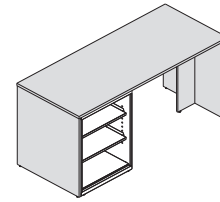

Peninsula Application

- Peninsula applications can only be completed with 36"D worksurfaces and end panels.
- Back-to-back storage specified without an end panel will result in an ~3/8" gap between storage units.
- In a peninsula application, one end of the worksurface must be supported by undersurface storage. The opposing end can be supported with an O-leg or laminate end panel.

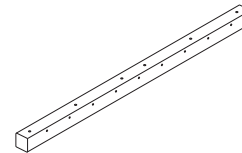

- Unsupported surface runs greater than 54"W require the installation of an external stiffener.
- External stiffener extends 1½" below the worksurface.
- For 36"W surfaces, 2 external stiffeners are needed on the underneath side of the worksurface.



	Width Sizes						
	S1	S2	S3	S4	S5	S6	S7
No End Panels	84.00"	S1 + 0.125	S1 + 0.25	S1 + 0.375	S1 + 0.5	S1 + 0.625	S1 + 0.75
1 End Panel	85.372"						
2 End Panels	86.744"						

*S1 spans a single storage unit, which is noted at the end of the model number. Start with the S1 number displayed in the table above. Depending on your Islands configuration, the top width increases accordingly based on the 2 factors below.

- The number of end panels you attach to the worksurface.
- The number of side-to-side storage units the surface spans.

NOTES:

- Use the width of the worksurface you select. Models correspond to the correct surface width.
- Span represents the total number of side-to-side units. Front-to-back units do not factor into number of units spanned.



STORAGE ISLANDS

Top Only Applications

	DESCRIPTION	MODEL	SHIP WEIGHT	CUBE	LIST PRICE BY LAMINATE GRADE	
					L1	L2
	Islands Tops, Single Depth					
	18"D x 24"W, Spans 1	HSISLAUTNPB2418S1	15	2.0	\$195	\$205
	18"D x 30"W, Spans 1	HSISLAUTNPB3018S1	18	2.5	\$220	\$231
	18"D x 36"W, Spans 1	HSISLAUTNPB3618S1	22	2.9	\$240	\$252
	18"D x 36"W, Spans 3	HSISLAUTNPB3618S3	22	2.9	\$255	\$268
	18"D x 42"W, Spans 1	HSISLAUTNPB4218S1	25	3.3	\$270	\$284
	18"D x 48"W, Spans 1	HSISLAUTNPB4818S1	28	3.8	\$290	\$305
	18"D x 48"W, Spans 2	HSISLAUTNPB4818S2	28	3.8	\$290	\$305
	18"D x 48"W, Spans 4	HSISLAUTNPB4818S4	28	3.8	\$290	\$305
	18"D x 60"W, Spans 1	HSISLAUTNPB6018S1	35	4.7	\$305	\$320
	18"D x 60"W, Spans 2	HSISLAUTNPB6018S2	35	4.7	\$305	\$320
	18"D x 60"W, Spans 5	HSISLAUTNPB6018S5	35	4.7	\$305	\$320
	18"D x 72"W, Spans 1	HSISLAUTNPB7218S1	42	5.6	\$330	\$347
	18"D x 72"W, Spans 2	HSISLAUTNPB7218S2	42	5.6	\$330	\$347
	18"D x 72"W, Spans 3	HSISLAUTNPB7218S3	42	5.6	\$330	\$347
	18"D x 72"W, Spans 6	HSISLAUTNPB7218S6	42	5.6	\$330	\$347
18"D x 84"W, Spans 1	HSISLAUTNPB8418S1	48	6.4	\$355	\$373	
18"D x 84"W, Spans 2	HSISLAUTNPB8418S2	48	6.4	\$355	\$373	
18"D x 84"W, Spans 7	HSISLAUTNPB8418S7	49	6.5	\$355	\$373	
	Islands Tops, Double Depth					
	36"D x 24"W, Spans 1	HSISLAUTNPB2436S1	29	3.8	\$341	\$358
	36"D x 30"W, Spans 1	HSISLAUTNPB3036S1	35	4.6	\$385	\$404
	36"D x 36"W, Spans 1	HSISLAUTNPB3636S1	42	5.3	\$420	\$441
	36"D x 36"W, Spans 3	HSISLAUTNPB3636S3	42	5.4	\$446	\$469
	36"D x 42"W, Spans 1	HSISLAUTNPB4236S1	49	6.2	\$473	\$496
	36"D x 48"W, Spans 1	HSISLAUTNPB4836S1	56	7.0	\$508	\$533
	36"D x 48"W, Spans 2	HSISLAUTNPB4836S2	56	7.0	\$508	\$533
	36"D x 48"W, Spans 4	HSISLAUTNPB4836S4	56	7.0	\$508	\$533
	36"D x 60"W, Spans 1	HSISLAUTNPB6036S1	69	8.6	\$534	\$560
	36"D x 60"W, Spans 2	HSISLAUTNPB6036S2	69	8.6	\$534	\$560
	36"D x 60"W, Spans 5	HSISLAUTNPB6036S5	70	8.7	\$534	\$560
	36"D x 72"W, Spans 1	HSISLAUTNPB7236S1	83	10.3	\$578	\$606
	36"D x 72"W, Spans 2	HSISLAUTNPB7236S2	83	10.3	\$578	\$606
	36"D x 72"W, Spans 3	HSISLAUTNPB7236S3	83	10.3	\$578	\$606
	36"D x 72"W, Spans 6	HSISLAUTNPB7236S6	83	10.3	\$578	\$606
36"D x 84"W, Spans 1	HSISLAUTNPB8436S1	96	11.9	\$621	\$652	
36"D x 84"W, Spans 2	HSISLAUTNPB8436S2	96	11.9	\$621	\$652	
36"D x 84"W, Spans 7	HSISLAUTNPB8436S7	97	12.0	\$621	\$652	

NOTES:

- Top specified to create "light" configuration . See page 703.
- Worksurfaces are made of 1/8" high-performance particleboard with 2mm edgeband and laminate on both sides of all surfaces.
- Grain direction on all worksurfaces runs horizontal.

HOW TO SPECIFY

<p>Select Model Number</p> <p>HSISLAUTNPB6036S5</p>	<p>Select Laminate</p> <p>See page 701</p> <p>LKI1</p>	<p>Select Edge</p> <p>See page 701</p> <p>KI</p>
---	--	--

STORAGE ISLANDS

Tops for Use with 2 End Panels

OPEN MARKET



Icon Legend on page 19

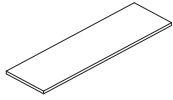

DESCRIPTION	MODEL	SHIP WEIGHT	CUBE	LIST PRICE BY LAMINATE GRADE	
				L1	L2
Islands Tops for use with End Panels					
18"D x 24"W, 2 End Panels, Spans 1	HSISLAUT2PNB2418S1	17	2.2	\$234	\$246
18"D x 30"W, 2 End Panels, Spans 1	HSISLAUT2PNB3018S1	20	2.6	\$264	\$277
18"D x 36"W, 2 End Panels, Spans 1	HSISLAUT2PNB3618S1	23	3.1	\$288	\$302
18"D x 36"W, 2 End Panels, Spans 3	HSISLAUT2PNB3618S3	23	3.1	\$293	\$308
18"D x 42"W, 2 End Panels, Spans 1	HSISLAUT2PNB4218S1	27	3.5	\$324	\$340
18"D x 48"W, 2 End Panels, Spans 2	HSISLAUT2PNB4818S2	30	4.0	\$348	\$365
18"D x 48"W, 2 End Panels, Spans 4	HSISLAUT2PNB4818S4	30	4.0	\$348	\$365
18"D x 60"W, 2 End Panels, Spans 2	HSISLAUT2PNB6018S2	37	4.9	\$366	\$384
18"D x 60"W, 2 End Panels, Spans 5	HSISLAUT2PNB6018S5	37	4.9	\$366	\$384
18"D x 72"W, 2 End Panels, Spans 2	HSISLAUT2PNB7218S2	44	5.8	\$396	\$416
18"D x 72"W, 2 End Panels, Spans 3	HSISLAUT2PNB7218S3	44	5.8	\$396	\$416
18"D x 72"W, 2 End Panels, Spans 6	HSISLAUT2PNB7218S6	44	5.8	\$363	\$381
18"D x 84"W, 2 End Panels, Spans 2	HSISLAUT2PNB8418S2	51	6.6	\$426	\$447
18"D x 84"W, 2 End Panels, Spans 7	HSISLAUT2PNB8418S7	51	6.7	\$426	\$447

NOTES:

- Top specified to create "medium" configuration . See page 703.
- Worksurfaces are made of 1½" high-performance particleboard with 2mm edgeband and laminate on both sides of all surfaces.
- Grain direction on all worksurfaces runs horizontal.

HOW TO SPECIFY

Select Model Number H S I S L A U T 2 P N B 3 6 1 8 S 3 .	Select Laminate See page 701 L K I 1 .	Select Edge See page 701 K I
---	---	---



STORAGE ISLANDS

Tops for Use with 2 End Panels and Back/Septum

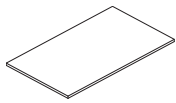
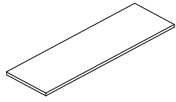

DESCRIPTION	MODEL	SHIP WEIGHT	CUBE	LIST PRICE BY LAMINATE GRADE	
				L1	L2
Islands Tops for Use with 2 End Panels and Back/Septum					
18"D x 48"W, 2 End Panels and Back, Spans 2	HSISLAUT2PYB4818S2	32	4.4	\$363	\$381
18"D x 48"W, 2 End Panels and Back, Spans 4	HSISLAUT2PYB4818S4	32	4.4	\$363	\$381
18"D x 60"W, 2 End Panels and Back, Spans 2	HSISLAUT2PYB6018S2	39	5.4	\$381	\$400
18"D x 60"W, 2 End Panels and Back, Spans 5	HSISLAUT2PYB6018S5	39	5.4	\$381	\$400
18"D x 72"W, 2 End Panels and Back, Spans 2	HSISLAUT2PYB7218S2	46	6.3	\$413	\$433
18"D x 72"W, 2 End Panels and Back, Spans 3	HSISLAUT2PYB7218S3	46	6.3	\$413	\$433
18"D x 72"W, 2 End Panels and Back, Spans 6	HSISLAUT2PYB7218S6	46	6.3	\$413	\$433
18"D x 84"W, 2 End Panels and Back, Spans 2	HSISLAUT2PYB8418S2	53	7.3	\$444	\$466
18"D x 84"W, 2 End Panels and Back, Spans 7	HSISLAUT2PYB8418S7	54	7.3	\$444	\$466
<hr/>					
36"D x 48"W, 2 End Panels and Septum, Spans 2	HSISLAUT2PYB4836S2	59	7.4	\$609	\$639
36"D x 48"W, 2 End Panels and Septum, Spans 4	HSISLAUT2PYB4836S4	59	7.4	\$609	\$639
36"D x 60"W, 2 End Panels and Septum, Spans 2	HSISLAUT2PYB6036S2	72	9.0	\$641	\$673
36"D x 60"W, 2 End Panels and Septum, Spans 5	HSISLAUT2PYB6036S5	73	9.0	\$641	\$673
36"D x 72"W, 2 End Panels and Septum, Spans 2	HSISLAUT2PYB7236S2	86	10.6	\$693	\$728
36"D x 72"W, 2 End Panels and Septum, Spans 3	HSISLAUT2PYB7236S3	86	10.6	\$693	\$728
36"D x 72"W, 2 End Panels and Septum, Spans 6	HSISLAUT2PYB7236S6	86	10.7	\$693	\$728
36"D x 84"W, 2 End Panels and Septum, Spans 2	HSISLAUT2PYB8436S2	99	12.3	\$746	\$783
36"D x 84"W, 2 End Panels and Septum, Spans 7	HSISLAUT2PYB8436S7	100	12.4	\$746	\$783

NOTES:

- Top specified to create "heavy" configuration . See page 703.
- Worksurfaces are made of 1½" high-performance particleboard with 2mm edgeband and laminate on both sides of all surfaces.
- Grain direction on all worksurfaces runs horizontal.

STORAGE

HOW TO SPECIFY

<p>Select Model Number</p> <p>HSISLAUT2PYB6036S2</p>	<p>Select Laminate</p> <p>See page 701</p> <p>LKI1</p>	<p>Select Edge</p> <p>See page 701</p> <p>KI</p>
---	---	---

STORAGE ISLANDS

Islands Tops for Use with 1 End Panel and Septum

OPEN MARKET



Icon Legend on page 19

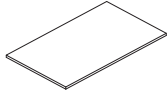

DESCRIPTION	MODEL	SHIP WEIGHT	CUBE	LIST PRICE BY LAMINATE GRADE	
				L1	L2
Islands Tops for Use with One End Panel & Septum					
36"D x 48"W, 1 End Panel and Septum, Spans 2	HSISLAUTIPYB4836S2	57	7.2	\$584	\$613
36"D x 48"W, 1 End Panel and Septum, Spans 4	HSISLAUTIPYB4836S4	57	7.2	\$584	\$613
36"D x 60"W, 1 End Panel and Septum, Spans 2	HSISLAUTIPYB6036S2	71	8.8	\$614	\$645
36"D x 60"W, 1 End Panel and Septum, Spans 5	HSISLAUTIPYB6036S5	71	8.9	\$614	\$645
36"D x 72"W, 1 End Panel and Septum, Spans 2	HSISLAUTIPYB7236S2	84	10.5	\$664	\$697
36"D x 72"W, 1 End Panel and Septum, Spans 3	HSISLAUTIPYB7236S3	84	10.5	\$664	\$697
36"D x 72"W, 1 End Panel and Septum, Spans 6	HSISLAUTIPYB7236S6	85	10.5	\$664	\$697
36"D x 84"W, 1 End Panel and Septum, Spans 2	HSISLAUTIPYB8436S2	98	12.1	\$714	\$750
36"D x 84"W, 1 End Panel and Septum, Spans 7	HSISLAUTIPYB8436S7	98	12.2	\$714	\$750

NOTES:

- Worksurfaces are made of 1½" high-performance particleboard with 2mm edgeband and laminate on both sides of all surfaces.
- Grain direction on all worksurfaces runs horizontal.
- Single end panel application designed to join worksurfaces to create run greater than 84".

DESCRIPTION	MODEL	SHIP WEIGHT	CUBE	LIST PRICE
 Flat Bracket 18"D	HHN831118	3 Ⓢ	0.2	\$64

NOTES: Use the flat bracket in countertop applications where 2 worksurfaces come together and there is not a storage unit or end panel connecting them.

ⓘ Available in Charcoal only.

NOTES:

- Top specified to create "joint" configuration. See page 703.
- ⓘ 36"W with back-to-back storage without an end panel will result in approximately ⅜" exposed gap between storage units.

HOW TO SPECIFY

<p>Select Model Number</p> <p>HSISLAUT1PYB6036S5</p>	<p>Select Laminate</p> <p>See page 701</p> <p>LK11</p>	<p>Select Edge</p> <p>See page 701</p> <p>KI</p>
--	--	--



STORAGE ISLANDS

Islands Septum/Back and End Panels

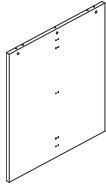

DESCRIPTION	MODEL	SHIP WEIGHT	CUBE	LIST PRICE BY LAMINATE GRADE	
				L1	L2
Islands End Panels, Contain® Height					
42”H x 18”W, Contain® Height, No Back	HSISLACENB1842	24	3.3	\$198	\$208
42”H x 18”W, Contain® Height, Back, Left-Hand	HSISLACEYB1842L	26	3.3	\$198	\$208
42”H x 18”W, Contain® Height, Back, Right-Hand	HSISLACEYB1842R	26	3.3	\$198	\$208
42”H x 36”W, Contain® Height, No Septum	HSISLACEYB3642	45	6.0	\$347	\$364
42”H x 36”W, Contain® Height, Septum	HSISLACESP3642	45	6.0	\$347	\$364
Islands End Panels, Flagship® Height					
42”H x 18”W, Flagship® Height, No Back	HSISLAFENB1842	24	3.1	\$198	\$208
42”H x 18”W, Flagship® Height, Back, Left-Hand	HSISLAFEBYB1842L	24	3.1	\$198	\$208
42”H x 18”W, Flagship® Height, Back, Right-Hand	HSISLAFEBYB1842R	24	3.1	\$198	\$208
42”H x 36”W, Flagship® Height, No Septum	HSISLAFEBYB3642	47	5.7	\$347	\$364
42”H x 36”W, Flagship® Height, Septum	HSISLAFESP3642	47	5.7	\$347	\$364

NOTES: Panels are made of 1½” high-performance particleboard with 2mm edgeband and laminate on both sides of all surfaces. Grain direction on all End Panels runs vertical. 18”W end panels require selection of right or left model numbers for installation purposes.

! Models HSISLACESP3642 and HSISLAFESP3642 come with short end panel which can be discarded when used as an end panel.

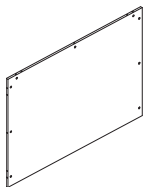

Islands Septum/Back, Contain® Height					
42”H x 48”W, 2 End Panels, Spans 2	HSISLACB2P4842S2	42	8.1	\$332	\$349
42”H x 72”W, 2 End Panels, Spans 3	HSISLACB2P7242S3	63	11.9	\$428	\$449
42”H x 48”W, 2 End Panels, Spans 4	HSISLACB2P4842S4	42	8.1	\$332	\$349
42”H x 60”W, 2 End Panels, Spans 5	HSISLACB2P6042S5	53	10.0	\$365	\$383
42”H x 72”W, 2 End Panels, Spans 6	HSISLACB2P7242S6	63	11.9	\$428	\$449
42”H x 84”W, 2 End Panels, Spans 7	HSISLACB2P8442S7	73	13.8	\$520	\$546
Islands Septum/Back, Flagship® Height					
42”H x 60”W, 2 End Panels, Spans 2	HSISLAFB2P6042S2	50	10.0	\$365	\$383
42”H x 72”W, 2 End Panels, Spans 2	HSISLAFB2P7242S2	59	11.9	\$428	\$449
42”H x 84”W, 2 End Panels, Spans 2	HSISLAFB2P8442S2	69	13.7	\$520	\$546

NOTES: Septums/Backs are made of ¾” high-performance particleboard with 0.5mm edgeband and laminate on both sides of all surfaces. Grain direction on all Septums/Backs runs horizontal.

NOTES:

- End panels and septum are shipped with mounting hardware included, 1/pack.

HOW TO SPECIFY

<p>Select Model Number</p>	<p>Select Laminate</p> <p>See page 701</p>
<p>H S I S L A C B 2 P 6 0 4 2 S 5</p>	<p>L K I I</p>

STORAGE ISLANDS

Peninsula Supports

OPEN MARKET



Icon Legend on page 19

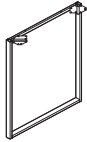

DESCRIPTION

Islands O-Leg
42"H x 36"W, Contain® Height
42"H x 36"W, Flagship® Height

MODEL

HSISLACO3642
HSISLAF03642

SHIP WEIGHT

21
21

CUBE

6.8
6.8

LIST PRICE BY PAINT GRADE

P1	P2	P3
\$500	\$508	\$520
\$500	\$508	\$520

DESCRIPTION

External Support Channel
42"W for a 54" Open Worksurface Run
48"W for a 60" Open Worksurface Run
54"W for a 66" Open Worksurface Run
60"W for a 72" Open Worksurface Run
72"W for an 84" Open Worksurface Run

MODEL

HLSLZ5SC54
HLSLZ5SC60
HLSLZ5SC66
HLSLZ5SC72
HLSLZ5SC84

SHIP WEIGHT

5
6
7
7
12

CUBE

0.5
0.5
0.5
0.5
0.7

LIST PRICE

\$93
\$98
\$101
\$110
\$110

NOTES: 36"W surfaces will need 2 external stiffeners on either side of the worksurface.

📌 Available in Graphite paint only.

DESCRIPTION

Islands Return Panels
42"H x 36"W, Contain® Height, Return Panel
42"H x 36"W, Flagship® Height, Return Panel

MODEL

HSISLACESP3642
HSISLAFESP3642

SHIP WEIGHT

56
58

CUBE

4.6
4.6

LIST PRICE BY LAMINATE GRADE

L1	L2
\$346	\$364
\$347	\$364

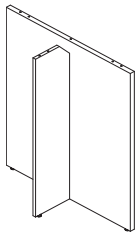

NOTES:

- Voi® O-legs installed in peninsula application are centered front-to-back on the worksurface. The O-leg will be 1/2" inset from the edge of the worksurface.
- 📌 When specifying a peninsula application, at least one side of the open worksurface span must be supported with undersurface storage. Islands tops cannot be specified with only O-leg or Laminate Return Panel supports.

HOW TO SPECIFY

Select Model Number H S I S L A C O 3 6 4 2 .	Select Paint/Laminate See page 701 T 1
---	---

400 SERIES



400 Series Lateral Files.

STORAGE

400 SERIES

Economical 400 Series lateral files from HON offer features not often found on competitors' files, such as a tamper-resistant enclosed base and factory-installed counterweights on two- and four-drawer cabinets to stabilize the center of gravity when a drawer is opened. Even the removable lock core system stands out among higher-priced rivals.



FEATURES

- Lateral files have counterweights for stability and a two-sided lock mechanism that resists tampering.
- Removable lock core can be changed as security needs require.
- Leveling glides compensate for uneven floors.
- Heavy-duty Steel ball-bearing drawer suspensions operate easily and quietly.
- Four vertical reinforcements keep the cabinet sturdy and the drawers gliding smoothly.
- Drawer handle design coordinates with HON Metro Classic Steel desks.

400 SERIES Lateral Files

OPEN MARKET

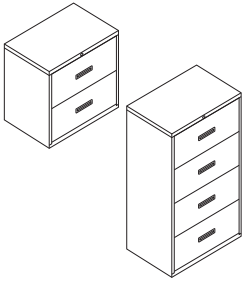

DESCRIPTION

Steel Lateral Files

- 30"W x 18"D x 28"H — 2 Drawer
- 30"W x 18"D x 53½"H — 4 Drawer
- 36"W x 18"D x 28"H — 2 Drawer
- 36"W x 18"D x 53½"H — 4 Drawer

NOTES: Drawers lock. Features ball-bearing slide suspensions.

MODEL	SHIP WEIGHT	CUBE	LIST PRICE
H432	109	12.4	\$776
H434	169	22.1	\$1143
H482	124	12.4	\$810
H484	185	22.1	\$1305

STORAGE

NOTES:

- Reinforced case construction.
- Two adjustable leveling glides in front corners.
- Baked enamel finish.
- Monochromatic drawer pulls.
- **HON 5-Year Limited Warranty.**

HOW TO SPECIFY

<p>Select Model Number</p> <p>H 4 3 2 .</p>	<p>Select Lock Option</p> <p>L Lock</p> <p>L .</p>	<p>Select Paint Color</p> <p>P Black</p> <p>Q Light Gray</p> <p>LOFT Loft</p> <p>L Putty</p> <p>P</p>
--	---	--

VERTICAL FILES



310 Series Verticals with Perpetual® Seating.

STORAGE

VERTICAL FILES

Have lots to store but not a lot to spend? HON has a lot of filing solutions to fit your budget. Perfect for small businesses, home and professional offices, schools and more, HON's vertical files are value priced and available in multiple styles and sizes.



FEATURES

- Our vertical filing cabinets offer both legal and letter drawer sizes to accommodate all your filing needs.
- HON One Key core removable locks can be changed or interchanged as security demands change.
- Double-walled front kickplate stands up to impact.
- High drawer sides support hanging file folders, eliminating the need for extra-cost hangrails.

VERTICAL FILES ORDERING INFORMATION

210, 310, H320 & 510 VERTICAL FILES

PAINTS CODES

P1

- ◆ Black P
- ◆ Brownstone P7D
- ◆ Charcoal S
- ◆ Designer White PJW
- ◆ Fossil P28
- ◆ Greige T5
- ◆ Light Gray Q
- ◆ Loft LOFT
- ◆ Muslin T3
- ◆ Putty L
- ◆ Shadow * SHDW
- ◆ Titanium P8T

P2

- ◆ Champagne Metallic T4
- ◆ Platinum Metallic T1

STORAGE

For Champagne Metallic Paint, Muslin is the suggested edgeband color.

◆◆◆ For lead time information see page 19.

* De-emphasized



Icon Legend on page 19

210 SERIES Vertical Files

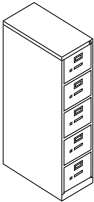
	DESCRIPTION	MODEL	SHIP WEIGHT	CUBE	LIST PRICE BY PAINT GRADE		
					P1	P2	P3
	Vertical File — 2 Drawer 15"W x 28½"D x 29"H, Letter 18¼"W x 28½"D x 29"H, Legal	H212 H212C	65 71	11.92 14.06	\$821 \$997	\$849 \$1025	\$877 \$1053
	Vertical File — 4 Drawer 15"W x 28½"D x 52"H, Letter 18¼"W x 28½"D x 52"H, Legal	H214 H214C	114 123	19.64 23.18	\$1066 \$1266	\$1111 \$1311	\$1155 \$1355
	Vertical File — 5 Drawer 15"W x 28½"D x 60"H, Letter 18¼"W x 28½"D x 60"H, Legal	H215 H215C	136 145	22.31 26.33	\$1425 \$1692	\$1470 \$1737	\$1514 \$1781

STORAGE

NOTES:

- High capacity file, 28½" Case depth with 27 front-to-back filing inches per drawer.
- Letter or legal sizes available.
- Three-part, telescoping, steel ball-bearing suspension.
- Bright aluminum drawer pulls, label holders and thumb latch.
- Standard interchangeable core removable locks. Equipped with HON "One Key" system.
- Accepts hanging files. High drawer sides hold hanging file folders without use of hangrails.
- Spring loaded follower block with positive side-action positioning is adjustable on 5/8" centers.
- Baked enamel finish over rust-inhibiting phosphate pre-treatment.
- See page 721 for Vertical File Accessories.

ⓘ Keyed alike cores must be ordered separately — see page 746.

HOW TO SPECIFY

<p>Select Model Number</p> <p>H 2 1 2 .</p>	<p>Select Lock Option</p> <p>P Lock</p> <p>P .</p>	<p>Select Paint Color</p> <p>See page 716</p> <p>T 1</p>
--	---	---

310 SERIES Vertical Files

GSA SIN 33721



Icon Legend on page 19

STORAGE



DESCRIPTION

Vertical File — 2 Drawer
15"W x 26½"D x 29"H, Letter
18¼"W x 26½"D x 29"H, Legal

MODEL	SHIP WEIGHT	CUBE	LIST PRICE BY PAINT GRADE		
			P1	P2	P3
H312	60	9.2	\$493	\$521	\$549
H312C	66	13.2	\$628	\$656	\$684

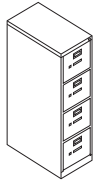

Vertical File — 4 Drawer
15"W x 26½"D x 52"H, Letter
18¼"W x 26½"D x 52"H, Legal

H314	107	16.03	\$670	\$715	\$759
H314C	116	21.76	\$822	\$867	\$911

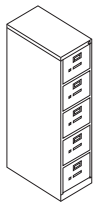

Vertical File — 5 Drawer
15"W x 26½"D x 60"H, Letter
18¼"W x 26½"D x 60"H, Legal

H315	128	20.94	\$982	\$1027	\$1071
H315C	137	24.72	\$1174	\$1219	\$1263

NOTES:

- 26½" Case depth with 25 front-to-back filing inches per drawer.
- Letter or legal sizes available.
- Three-part, telescoping, steel ball-bearing suspension.
- Bright aluminum drawer pulls, label holders and thumb latch.
- Standard interchangeable core removable locks. Equipped with HON "One Key" system.
- Accepts hanging files. High drawer sides hold hanging file folders without use of hangrails.
- Spring loaded follower block with positive side-action positioning is adjustable on ⅝" centers.
- Baked enamel finish over rust-inhibiting phosphate pre-treatment.
- See page 721 for Vertical File Accessories.

Keyed alike cores must be ordered separately — see page 746.

HOW TO SPECIFY

Select Model Number

H 3 1 2 .

Select Lock Option

P Lock

P .



Select Paint Color

See page 716

T 1



510 SERIES Vertical Files

	DESCRIPTION	MODEL	SHIP WEIGHT	CUBE	LIST PRICE BY PAINT GRADE		
					P1	P2	P3
	Vertical File — 2 Drawer						
	15"W x 25"D x 29"H, Letter 18¼"W x 25"D x 29"H, Legal	H512  H512C	58 63	8.12 9.71	\$430 \$551	\$458 \$579	\$486 \$607
	Vertical File — 4 Drawer						
	15"W x 25"D x 52"H, Letter 18¼"W x 25"D x 52"H, Legal	H514  H514C	102 112	17.42 20.65	\$580 \$712	\$625 \$757	\$669 \$801

NOTES:

- 25" Case depth with 23½" front-to-back filing inches per drawer.
 - Letter and legal sizes are available.
 - Three-part telescoping, ball-bearing steel suspension.
 - Bright aluminum drawer pulls, label holders and thumb latch.
 - Standard interchangeable core removable locks. Equipped with HON "One Key" system.
 - Accepts hanging files. High drawer sides hold hanging file folders without use of hangrails.
 - Adjustable wire follower.
 - Baked enamel finish over rust-inhibiting phosphate pre-treatment.
-  Keyed alike cores must be ordered separately — see page 746.

STORAGE

HOW TO SPECIFY

<p>Select Model Number</p> <p>H 5 1 2 .</p>	<p>Select Lock Option</p> <p>P Lock</p> <p>P .</p>	<p>Select Paint Color</p> <p>See page 716</p> <p>T 1</p>
--	---	---



LATERAL FILE ACCESSORIES

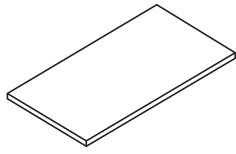

DESCRIPTION

Square Edge Laminate Top

30"W x 18"D x 1/8" Thick
 36"W x 18"D x 1/8" Thick
 42"W x 18"D x 1/8" Thick
 60"W x 18"D x 1/8" Thick
 66"W x 18"D x 1/8" Thick
 72"W x 18"D x 1/8" Thick

MODEL

SHIP WEIGHT

CUBE

LIST PRICE

H919430	20.0	1.6	\$408
H919436	25.0	1.8	\$512
H919442	30.0	2.1	\$559
H919460	32.0	3.0	\$706
H919466	40.0	3.2	\$807
H919472	48.0	3.5	\$829

NOTES: Compatible with Flagship® and Brigade® 18"D Lateral Files only. Laminate tops are abrasion- and stain-resistant laminate. See Storage Islands pages for broad offering of laminate top options compatible with Contain®, Flagship®, and Brigade®.

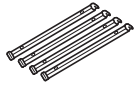

Single Rail Hanging File Racks (4/pack)

H919491

1.0

0.4

\$67

NOTES: For front-to-back filing — 30"W, 36"W and 42"W files. Order one package per drawer for 42"W files. One package will do two 30"W or 36"W file drawers. Racks span between 15 1/4"W rails. Hanging file racks and dividers available in Gray only.

Gray only.

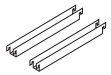

Double-Rail Hanging File Racks (2/pack)

H919492

1.5

0.4

\$67

NOTES: For 3 rows front-to-back — 42"W files. Order one package per drawer. Racks span between 15 1/4"W rails. Hanging file racks and dividers available in Gray only.

Gray only.

NOTES:

- Compatible with Flagship®, Brigade® 800, 700, 600, and 500 Series Lateral Files.
- See Contain® Accessories for hanging file racks compatible with Contain® Storage Products.

HOW TO SPECIFY

Select Model Number <div style="display: flex; gap: 5px;"> <div style="border: 1px solid black; padding: 2px;">H</div> <div style="border: 1px solid black; padding: 2px;">9</div> <div style="border: 1px solid black; padding: 2px;">1</div> <div style="border: 1px solid black; padding: 2px;">9</div> <div style="border: 1px solid black; padding: 2px;">4</div> <div style="border: 1px solid black; padding: 2px;">3</div> <div style="border: 1px solid black; padding: 2px;">0</div> </div>	Select Laminate See page 627 <div style="border: 1px solid black; padding: 2px; display: inline-block;">N</div>
---	--

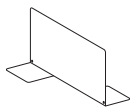

DESCRIPTION

Metal File Divider

10 pack
 2 pack

MODEL

SHIP WEIGHT

CUBE

LIST PRICE

HSCAFD10
HSCAFD02

12
 3

0.7
 0.7



\$202
\$53

Metal dividers available in Black only. No need to specify.



Icon Legend on page 19

VERTICAL FILE ACCESSORIES

	DESCRIPTION	MODEL	SHIP WEIGHT	CUBE	LIST PRICE
 SIN 33721	Follower Block (4/pack)				
	Legal	HF60	8.0	0.6	\$105
	Letter	HF50	7.0	0.5	\$99
  <i>Lock info page 746.</i> OPEN MARKET	Chrome Core Removable Lock Kit (Field installable)	HF24	0.2	0.2	\$60
	Specify key number from 101E-225E. Lock info page 746. Bulk Package — 6 HF24 Lock Kits (Individually shrink wrapped)	HF246	1.2	0.2	\$279

STORAGE

HOW TO SPECIFY

Select Model Number

HF60

MOBILE PEDESTALS



Icon Legend on page 19

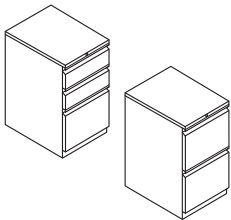

DESCRIPTION

Mobile Pedestal
15"W x 20"D x 28"H, Box/Box/File
15"W x 20"D x 28"H, File/File

MODEL SHIP WEIGHT CUBE LIST PRICE

HBMP2B	60	6.9	\$521
HBMP2F	60	6.9	\$521

NOTES:

- Pencil tray standard in top box drawer.
- One box divider standard in each box drawer.
- One crossrail standard in each file drawer.
- Ball-bearing suspension with 90% extension.
- Steel frame construction for everyday use.
- **HON 5-Year Limited Warranty.**

STORAGE

HOW TO SPECIFY

<p>Select Model Number</p> <p>H B M P 2 B .</p>	<p>Select Paint Color</p> <p>P Black Q Light Gray L Putty</p> <p>P</p>
--	---



Icon Legend on page 19

PEDESTAL ACCESSORIES

	DESCRIPTION	MODEL	SHIP WEIGHT	CUBE	LIST PRICE
	Counterweight — Freestanding Support Pedestals or Systems Support and Mobile Pedestals	HPCW1	18.0	0.1	\$201
	Follower Block — 1-Pack. Gray only.	HF80	1.0	0.3	\$51
	Double-Rail Hanging File Racks — 2-Pack. Gray only (for side-to-side).	H519495	0.5	0.5	\$34
	Adjustable Glides — 4-Pack Field installable, used to convert mobile pedestals to freestanding support pedestals.	H20040AG	1.0	0.6	\$64
	NOTES: Hardware included. Compatible with Contain®.				
	Caster Package — Field Installable Four Casters (2 swivel, 2 fixed)	H1050CST	1.0	0.6	\$46
	NOTES: Used to convert Freestanding Support Pedestals to Mobile Pedestals. Does not work on Contain® or Flagship® B/F mobile pedestals. Not designed to be used on pedestals without a counterweight.				
	Lock Core Replacement Kit — Chrome (Specify quantity of each key number from 101E-225E.) Contains one core, two keys, one core removable tool and instructions. Refer to page 746.	HF23C	0.1	0.1	\$44
	SIN 33721 Master Key (one key) — Available to authorized dealers only.	HF22	0.1	0.1	\$26
	OPEN MARKET				

NOTES:

- Compatible with Flagship®, Brigade® and Systems Support Pedestals.

HOW TO SPECIFY

Select Model Number

H F 2 3 C

	DESCRIPTION	MODEL	SHIP WEIGHT	CUBE	FABRIC PRICE CODES																												
 OPEN MARKET	Pedestal Seat 15"W x 18"D x 2"H NOTES: For seating fabrics, see pages 22-24. Works with Contain® and Flagship® Pedestals and Mobile Pedestals.	HPSEAT18ND	16.3	0.9	<table border="0"> <tr><td>1</td><td>\$170</td><td>8</td><td>\$366</td></tr> <tr><td>2</td><td>\$194</td><td>9</td><td>\$397</td></tr> <tr><td>3</td><td>\$218</td><td>10</td><td>\$428</td></tr> <tr><td>4</td><td>\$242</td><td>11</td><td>\$459</td></tr> <tr><td>5</td><td>\$273</td><td>12</td><td>\$490</td></tr> <tr><td>6</td><td>\$304</td><td>L</td><td>—</td></tr> <tr><td>7</td><td>\$335</td><td></td><td></td></tr> </table>	1	\$170	8	\$366	2	\$194	9	\$397	3	\$218	10	\$428	4	\$242	11	\$459	5	\$273	12	\$490	6	\$304	L	—	7	\$335		
	1	\$170	8	\$366																													
	2	\$194	9	\$397																													
	3	\$218	10	\$428																													
	4	\$242	11	\$459																													
	5	\$273	12	\$490																													
	6	\$304	L	—																													
	7	\$335																															
 OPEN MARKET	Pedestal Seat 15"W x 22 7/8"D x 2"H NOTES: For seating fabrics, see pages 22-24. Works with Contain® and Flagship® Pedestals and Mobile Pedestals.	HPSEAT24ND	10.0	1.2	<table border="0"> <tr><td>1</td><td>\$200</td><td>8</td><td>\$396</td></tr> <tr><td>2</td><td>\$224</td><td>9</td><td>\$427</td></tr> <tr><td>3</td><td>\$248</td><td>10</td><td>\$458</td></tr> <tr><td>4</td><td>\$272</td><td>11</td><td>\$489</td></tr> <tr><td>5</td><td>\$303</td><td>12</td><td>\$520</td></tr> <tr><td>6</td><td>\$334</td><td>L</td><td>—</td></tr> <tr><td>7</td><td>\$365</td><td></td><td></td></tr> </table>	1	\$200	8	\$396	2	\$224	9	\$427	3	\$248	10	\$458	4	\$272	11	\$489	5	\$303	12	\$520	6	\$334	L	—	7	\$365		
	1	\$200	8	\$396																													
	2	\$224	9	\$427																													
	3	\$248	10	\$458																													
	4	\$272	11	\$489																													
	5	\$303	12	\$520																													
	6	\$334	L	—																													
	7	\$365																															

HOW TO SPECIFY

Select Model Number

Select Fabric

See pages 22-24 for seating fabric options

H P S E A T 2 4 . **A P N 2 3**

STORAGE

PEDESTAL ACCESSORIES

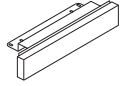

DESCRIPTION

Flush Front Kick Plate
For 28"H Flagship® Pedestals

MODEL	SHIP WEIGHT	CUBE	LIST PRICE BY PAINT GRADE		
			P1	P2	P3
HKP2800	3 Ⓞ	0.2	\$116	\$124	\$129

NOTES:

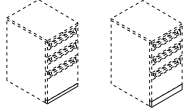

- Mounts to base of pedestal to provide a flush appearance to coordinate with laterals, file centers and storage towers.
- Kick plate is field installable.

DESCRIPTION

Optional Pencil Tray

NOTES: For additional information see the Workplace Tools section in the 2021 Shared Spaces Pricer.

ⓘ For use with mobile and freestanding pedestal models.

ⓘ No specification required.

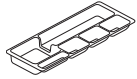

HOW TO SPECIFY

Select Model Number HKP2800	Select Paint Color See page 627 P
---------------------------------------	--

LAMINATE BOOKCASES



1870 Series Bookcases.

STORAGE

LAMINATE BOOKCASES

These sturdy laminate bookcases coordinate with most HON laminate desks. The scratch-, spill- and stain-resistant laminate will ensure that they keep their good looks.



1870 SERIES FEATURES

- Shelves adjust on 1/4" increments.
- Leveling glides keep them nicely aligned, even if the floor isn't.
- Easy to assemble, using high-precision cam-locks and wood dowels, with no glue needed.

10500 SERIES FEATURES

- Ship fully assembled and ready to use.
- Adjustable leveling glides compensate for uneven floors.
- Available in a broad palette of laminate colors.



BOOKCASES ORDERING INFORMATION

STORAGE

10500 SERIES™ BOOKCASES

L1 LAMINATES CODES

Woodgrain

- ◆ Bourbon Cherry H
- ◆ Cognac COGN
- ◆ Florence Walnut LFW1
- ◆ Harvest C
- ◆ Kingswood Walnut LK11
- ◆ Mahogany N
- ◆ Mocha MOCH
- ◆ Natural Maple D
- ◆ Pinnacle PINC
- ◆ Shaker Cherry F
- ◆ Sterling Ash LSA1

Solid

- ◆ Black P
- ◆ Charcoal S
- ◆ Designer White LDW1
- ◆ Loft LOFT

Patterned Top*

- ◆ Sheer Mesh A5
- ◆ Silver Mesh B9
- ◆ Canyon Zephyr K9
- ◆ Desert Zephyr K8
- ◆ Grey Tigris L6

L2 LAMINATES CODES

Woodgrain

- ◆ Lowell Ash LLA1
- ◆ Natural Recon LNR1
- ◆ Phantom Ecru LPE1
- ◆ Portico Teak LPT1
- ◆ Skyline Walnut LSW1

1870 SERIES BOOKCASES

L1 LAMINATES CODES

Woodgrain

- ◆ Cognac COGN
- ◆ Harvest C
- ◆ Mahogany N

10500 Series™ Laminate Bookcases

- Available Laminate Colors:

Woodgrain	Solid	Patterned Top*	Two-Tone (Top/Chassis)
Top and edgebanding are the same, chassis is different laminate color:			
L1 Laminates: Bourbon Cherry (HH) Cognac (COGNCOGN) Florence Walnut (LFWILFW1) Harvest (CC) Kingswood Walnut (LK11LK11) Mahogany (NN) Mocha (MOCHMOCH) Natural Maple (DD) Pinnacle (PINCPINC) Shaker Cherry (FF) Sterling Ash (LSA1LSA1)	Black (PP) Charcoal (SS) Designer White (LDWILDW1) Loft (LOFTLOFT)	Canyon Zephyr (K9) Desert Zephyr (K8) Grey Tigris (L6) Sheer Mesh (A5) Silver Mesh (B9)	Black/Charcoal (PS) Black/Designer White (PLDW1) Black/Loft (PLOFT) Bourbon Cherry/Black (HP) Bourbon Cherry/Charcoal (HS) Bourbon Cherry/Designer White (HLDW1) Bourbon Cherry/Loft (HLOFT) Charcoal/Black (SP) Charcoal/Designer White (SLDW1) Cognac/Black (COGNP) Cognac/Charcoal (COGNS) Cognac/Designer White (COGNLDW1) Cognac/Loft (COGNLOFT) Designer White/Black (LDW1P) Designer White/Bourbon Cherry (LDWIH) Designer White/Charcoal (LDWIS) Designer White/Cognac (LDWICOGN) Designer White/Harvest (LDW1C) Designer White/Loft (LDW1LOFT) Designer White/Lowell Ash (LDW1LLA1O) Designer White/Mahogany (LDWIN) Designer White/Mocha (LDW1MOCH) Designer White/Natural Maple (LDW1D) Designer White/Natural Recon (LDW1LNR1) Designer White/Phantom Ecru (LDW1LPE1) Designer White/Pinnacle (LDW1PINC) Designer White/Portico Teak (LDW1LPT1) Designer White/Shaker Cherry (LDW1F) Designer White/Skyline Walnut (LDW1LSW1) Florence Walnut/Black (LFW1P) Florence Walnut/Charcoal (LFW1S) Florence Walnut/Designer White (LFW1LDW1) Florence Walnut/Loft (LFW1LOFT) Harvest/Black (CP) Harvest/Charcoal (CS) Harvest/Designer White (CLDW1) Harvest/Loft (CLOFT) Kingswood Walnut/Black (LK11P) Kingswood Walnut/Charcoal (LK11S) Kingswood Walnut/Designer White (LK11LDW1) Kingswood Walnut/Loft (LK11LOFT) Loft/Black (LOFTP) Loft/Charcoal (LOFTS) Loft/Designer White (LOFTLDW1) Lowell Ash/Black (LLA1P) Lowell Ash/Charcoal (LLA1S) Lowell Ash/Designer White (LLA1LDW1) Lowell Ash/Loft (LLA1LOFT)
L2 Laminates: Lowell Ash (LLA1) Natural Recon (LNR1) Phantom Ecru (LPE1) Portico Teak (LPT1) Skyline Walnut (LSW1)		*Patterned Laminates are available with the following chassis/edgebanding laminate selection: Black (P) Bourbon Cherry (H) Charcoal (S) Designer White (LDW1) Florence Walnut (LFW1) Harvest (CC) Kingswood Walnut (LK11) Loft (LOFT) Mahogany (N) Natural Maple (D) Shaker Cherry (F) Sterling Ash (LSA1)	Edgebanding around top will match chassis laminate color selected.

Patterned Top

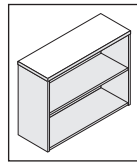

Edgeband Around Top/Laminate Base

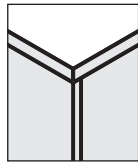

Two-Tone Laminate Top/Edgebanding

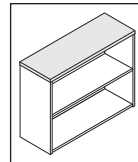

Laminate Base

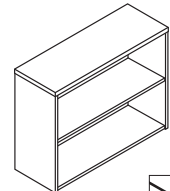
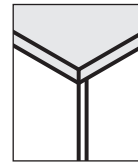

Square Corner Edge Detail



* NOTE: For patterned top laminates, select one of the following for the edgeband around the top, the shelves and vertical panels — Black (P), Bourbon Cherry (H), Charcoal (S), Cognac (COGN), Designer White (DW), Florence Walnut (LFW1), Harvest (C), Kingswood Walnut (LK11), Mahogany (N), Mocha (MOCH), Natural Maple (D), Pinnacle (PINC), Shaker Cherry (F), and Sterling Ash (LSA1).

◆◆◆ For lead time information see page 19.



10500 SERIES™ Laminate Bookcases

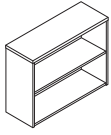

DESCRIPTION

Laminate Bookcase

- 36"W x 13 1/8"D x 29 3/8"H, 2-Shelf
- 36"W x 13 1/8"D x 43 3/8"H, 3-Shelf
- 36"W x 13 1/8"D x 57 1/8"H, 4-Shelf
- 36"W x 13 1/8"D x 71"H, 5-Shelf

MODEL	SHIP WEIGHT	CUBE	L1 LIST PRICE	L2 LIST PRICE
H105532	90	11.0	\$474	\$489
H105533	122	15.6	\$602	\$622
H105534	156	20.2	\$710	\$735
H105535	187	25.1	\$825	\$855

NOTES: Ships fully assembled. Fixed shelves. Inside shelf dimensions on all units are 33 1/4"W x 11 15/16"D x 12 15/16"H.

NOTES:

- 10500 Series™ Caseloads smooth, flat edge detail (see pages 244-295) complements many furniture designs.
- Fully finished back.
- Replaces 1980 Series Laminate Bookcases.
- Bottom shelf, top and end panels are 1 1/8" thick. Interior shelves are 3/4" thick.
- All surfaces finished in abrasion- and stain-resistant thermal-fused laminate over solid core high-performance particleboard.
- Adjustable hex leveling glides allow floor-standing bookcases to be easily leveled without lifting the unit; glides have 3/4" adjustable range.

STORAGE

HOW TO SPECIFY

<p>Select Model Number</p> <p>H 1 0 5 5 3 2 .</p>	<p>Select Laminate</p> <p>See page 726</p> <p>N N</p>
--	--

1870 SERIES Laminate Bookcases

GSA SIN 33721



Icon Legend on page 19

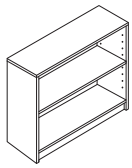

DESCRIPTION

Laminate Bookcase

- 36"W x 11½"D x 29⅞"H, 2-Shelf (1 adjustable)
- 36"W x 11½"D x 36⅞"H, 3-Shelf (2 adjustable)
- 36"W x 11½"D x 48¾"H, 4-Shelf (3 adjustable)
- 36"W x 11½"D x 60⅞"H, 5-Shelf (3 adjustable)
- 36"W x 11½"D x 72⅝"H, 6-Shelf (4 adjustable)
- 36"W x 11½"D x 84"H, 6-Shelf (4 adjustable)

MODEL

SHIP WEIGHT

CUBE

LIST PRICE

H1871	48	1.5	\$249
H1872	60	1.7	\$276
H1874	77	2.6	\$334
H1875	92	2.8	\$392
H1876	109	3.4	\$450
H1877	124	4.5	\$511

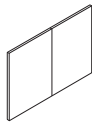

Set of doors with hinges used to conceal lower shelf contents
36"W x 25¾"H

H1801

23 **Ⓢ**

1.0

\$206

NOTES:

- Square edge profile complements many different furniture designs.
- Abrasion- and stain-resistant laminate, over durable solid core, high-performance particleboard.
- ¾" thick shelves adjust in ¼" increments to suit a variety of storage needs (two shelves are fixed in 5- and 6-shelf units).
- Cam-lock fasteners and wood dowels ensure pieces go together easily and precisely.
- Equipped with four adjustable leveling glides.
- Shelves will deflect under large amounts of weight.
- ⅛" hardboard back panel.
- All bookcases are 36"W x 11½"D.
- Optional doors available to conceal lower shelf contents.
- Choose from Harvest or Mahogany.
- Easy-to-assemble instructions included.

! Designed to be used in small office-home office applications.

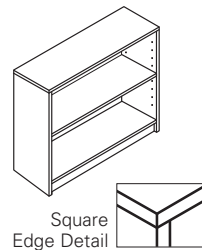

Square Edge Detail

STORAGE

HOW TO SPECIFY

Select Model Number

Select Laminate

- COGN** Cognac
- C** Harvest
- N** Mahogany

H 1 8 7 1 .

N

ACOUSTIC SOLUTIONS

by unika vaev



Drift ecoustic® Flat Surface Tiles shown with Flock® Dual Fabric Square Chair.

UNIKA VAEV

The workplace as we know it is evolving. With the increasing popularity of open concept layouts, the need for creative ways to divide space and absorb sound is greater than ever. Introducing HON acoustics by Unika Vaev. We've partnered with one of the most trusted brands in the acoustic industry to bring you several of their most popular models from their standard collection. This partnership will fulfill the growing need for sound absorption in the workplace by providing proven acoustic solutions sold by HON.

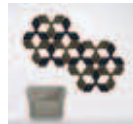

FEATURES

- Choose from wall, ceiling, and freestanding acoustic products.
- Unique shapes and designs allow for a functional and customized space.
- Freestanding and select hanging models allow for a creative way to divide your space.
- Blend in or stand out with multiple finish options.
- Products ship directly from Unika Vaev.
- Follows HON standard freight terms.
- Please see HON.com for care and installation guide.
- **HON 5-Year Limited Warranty.**

ACOUSTIC SOLUTIONS ORDERING INFORMATION

	ecoustic® Felt	Solid Core	Salsa	Dox	Fraster Felt
Wall-Mounted Tiles					
e3 Collection		•			
ecoustic® Foliar	•				
ecoustic® Linear	•				
ecoustic® Matrix	•				
ecoustic® Torque	•				
Ceiling-Mounted Tiles					
ecoustic® Arbor Alto		•			
ecoustic® Ceiling Flats		•			
ecoustic® Matrix	•				
ecoustic® Torque	•				
ecoustic® Measure Baffles		•			
Hanging Screens					
ScreenTrak® Bass Collection	•				
ScreenTrak® Alto		•			
Free-standing Screens					
MixMax					•
Softline			•	•	

(02/2020)

ScreenTrak and ecoustic are registered trademarks of Unika Vaev.

ACOUSTIC SOLUTIONS ORDERING INFORMATION

ECOUSTIC*

Lemon*	EF15
Baltic*	EF36
Nautical**	EF41
Paprika*	EF53
Berry*	EF55
Aqua*	EF62
Field*	EF68
Aubergine*	EF76
Fossil*	EF78
Dove**	EF87
Oyster**	EF88
Quartz*	EF92
Spray**	EF63
Cameo**	EF19
Caper*	EF64
Charcoal*	EF79
Cobalt*	EF35
Cream**	EF94
Fresco**	EF65
Green*	EF67
Indigo*	EF40
Jet*	EF80
Light Grey*	EF81
Lime*	EF66
Natural**	EF95
Oatmeal**	EF89
Opal**	EF93
Orange*	EF52
Pewter*	EF91
Red*	EF54

SOLID CORE

Almond	DAL1
Arizona	DAZ1
Bluebell	DBB1
Cool	DCL1
Galaxy	DGX1
Iris	DRS1
Leaf	DLF1
Oxide	DXD1
Snowdrop	DSW1
Tungsten	DTG1
Venus	DVN1
Denim	DDM1
Fawn	DFN1
Horizon	DHN1
Olive	DLV1

SALSA

Light Grey	SL30
Blue	SL31
Dark Mid Grey	DL32
Yellow	SL33
Dark Yellow	SL34
Green	SL35
Mid Grey	SL36
Pink	SL39
Dark Blue	SL40
Light Pink	SL54
Green	SL55
Brown	SL56
Beige	SL57

DOX

Black	DOX50
Dark Grey	DOX51
Middle Grey	DOX52
Light Grey	DOX53

FRASTER FELT

Red	FF102
Orange	FF105
Ochre	FF130
Wine	FF136
Off White	FF150
Beige	FF160
Silver	FF170
Charcoal	FF175
Beaver	FF190
Deer	FF220
Truffle	FF250
Mint	FF262
Curry	FF274
Azur	FF312
Citrus	FF398
Banana	FF399
Dust Green	FF415
Black	FF426
Aubergine	FF437
Moss	FF448
Sepia	FF463
Tomato	FF484
Flamingo	FF534
Midnight	FF539
Ocean	FF540
Sky	FF541







[Click here to view these options in the HON Surface Materials Guide.](#)

* Applied over Black solid core on ScreenTrak® Bass Hanging Screens.
** Applied over White solid core on ScreenTrak® Bass Hanging Screens.

ACOUSTIC SOLUTIONS

Wall

OPEN MARKET

	DESCRIPTION	MODEL	SHIP WEIGHT	CUBE	LIST PRICE
	e3 Solid Core Parallelogram 8¾" x 7½" x ½", Box of 15	HUVPAWT	5.0	0.2	\$938
	e3 Solid Core Triangle 8¾" Equilateral Sides, Box of 30	HUVTRWT	5.2	0.6	\$938
	e3 Solid Core Rectangle 8¾" x 17½", Box of 7	HUVREWT	5.4	1.0	\$938
	e3 Solid Core Large Square 8¾" x 8¾", Box of 15	HUVLSWT	5.2	0.6	\$892
	e3 Solid Core Small Square 2¼" x 2¼", Box of 60	HUVSSWT	5.2	0.6	\$892
	e3 Solid Core Wave 17½" x 8½", Box of 8	HUVVWWT	5.2	0.6	\$938
	e3 Solid Core Hexagon 17½" x 15¼", Box of 5	HUVHEWT	5.2	0.6	\$938



NOTES:

- Tiles sold in sets of individual shapes. Tiles can be arranged and combined to form larger and more intricate shapes. Attaches to wall by adhesive backing that ships already applied to the tiles.

Content: 100% PET (>50% Recycled PET)

Application: Wall

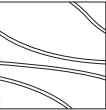
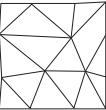
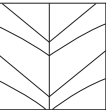
NRC: 0.40

	DESCRIPTION	MODEL	SHIP WEIGHT	CUBE	LIST PRICE
	Drift ecoustic® Wall Tiles 19¼"W x 19¼"H x 1¼"D, 8 per box NOTES: Attaches via wall clips. Content: 100% PET (>50% Recycled PET) Application: Wall NRC: 0.85	HUVDRT	13.2	4.3	\$3030
	Matrix ecoustic® Wall Tiles 19¼"W x 19¼"H x 1½"D, 8 per box NOTES: Attaches via wall clips. Content: 100% PET (>50% Recycled PET) Application: Wall NRC: 0.90	HUVMAWT	13.2	4.3	\$3030
	Torque ecoustic® Wall Tiles 22½"W x 22½"H x 1½"D, 8 per box NOTES: Attaches via wall clips. Content: 100% PET (>50% Recycled PET) Application: Wall NRC: 0.80	HUVTOWT	15.4	5.3	\$3030
	Foliar ecoustic® Wall Tiles 17½"W x 19¼"H x 23¼"D, 5 per box NOTES: Attachment plastic frame screws to the wall. Content: 100% PET (>50% Recycled PET) Application: Wall NRC: 0.80	HUVFOWT	9.0	3.0	\$2449

HOW TO SPECIFY

Select Model Number

Select Material

See page 730

Specify ecoustic® Felt for Wall Tiles and PET Solid Core for e3 Tiles

H U V D R W T .

E F 5 2

ACOUSTIC SOLUTIONS

Ceiling Tiles and Screens

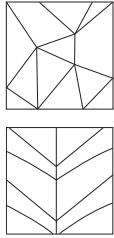

DESCRIPTION

Matrix ecoustic® Ceiling Tiles

23³/₁₆"W x 23³/₁₆"H x 2⁹/₁₆"D, Pack of 8 tiles
47¹/₁₆"W x 23³/₁₆"H x 2⁹/₁₆"D, Pack of 8 tiles

MODEL

SHIP WEIGHT

CUBE

LIST PRICE

HUVMAWT24	15.4	5.3	\$3091
HUVMAWT48	30.9	10.7	\$4652

Torque ecoustic® Ceiling Tiles

23³/₈"W x 23³/₈"H x 1⁷/₈"D, Pack of 8 tiles
47¹/₁₆"W x 23³/₈"H x 1⁷/₈"D, Pack of 8 tiles

HUVTOWT24	15.4	5.3	\$3091
HUVTOWT48	30.9	10.7	\$4652

NOTES: Matrix and Torque tile packs contain groups of eight solid colors. Fits directly into 2' x 2' or 2' x 4' drop ceiling grid. Tiles replace ceiling tiles already in the grid. Tiles slide into grid at an angle and are held in by the edge of the tile. No hardware is needed.

Content: 100% PET (>50% Recycled PET)

Application: Ceiling

NRC: 0.80 (Torque), 0.75 (Matrix)

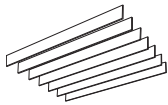

Measure Baffles

47"W x 10³/₄"H
96"W x 10³/₄"H

HUVMBHS48	15.0	0.8	\$1186
HUVMBHS96	30.0	1.6	\$1490

NOTES: Ships 4 per box with 4' hanging cords. Attaches via ceiling brackets (not included). Attachment hardware to ceiling should be procured by installers.

Content: 100% PET

Application: Ceiling

NRC: 0.80

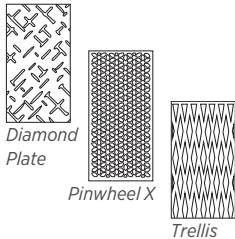

ScreenTrak® Bass Hanging Screen — Felt

95"H x 46"W x 1/2"D, Diamond Plate
95"H x 46"W x 1/2"D, Pinwheel X
95"H x 46"W x 1/2"D, Trellis

HUVSTBHSD	17.4	2.7	\$2440
HUVSTBHSP	17.4	2.7	\$2440
HUVSTBHST	17.4	2.7	\$2440

NOTES: Solid core with felt on top — black or white solid core is automatically assigned to each color. See page 730 for color/felt applications.

ScreenTrak® Alto Hanging Screen — Solid Color Core

95"H x 46"W x 1/2"D, Diamond Plate
95"H x 46"W x 1/2"D, Pinwheel X
95"H x 46"W x 1/2"D, Trellis

HUVSTAHS	17.4	2.7	\$2174
HUVSTAHS	17.4	2.7	\$2174
HUVSTAHS	17.4	2.7	\$2174

NOTES: Ships with 10' hanging cords.

! Ceiling attachment is not included due to many ceiling types and materials. Attachment hardware to ceiling should be procured by installers.

Content: 100% PET (>50% Recycled PET)

Application: Vertical Surfaces/Screens

NRC: 0.20

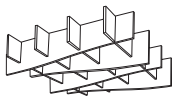

Arbor Alto ecoustic® Hanging Screen — Solid Color Core

48"H x 48"W x 4¹/₄"-7¹/₄"D

HUVAAHS	15.0	0.8	\$1267
----------------	------	-----	---------------

NOTES: Kit format contains 8 fins and 4' hanging cords.

! Ceiling attachment is not included due to many ceiling types and materials. Attachment hardware to ceiling should be procured by installers.

Content: 100% PET

Application: Ceiling

NRC: 0.80



ecoustic® Ceiling Flats

24" x 24", Box of 8
24" x 48", Box of 4

HUVCFCT24	15.4	5.3	\$2221
HUVCFCT48	30.9	10.7	\$2361

NOTES: Fits directly into 2' x 2' or 2' x 4' dropped ceiling grid. Flats replace ceiling tiles already in the grid. Tiles slide into grid at an angle and are held in by the edge of the tile. No hardware is needed.

Content: 100% PET (>50% Recycled PET)

Application: Ceiling

NRC: 0.85

Tiles are .47" thick.

UNIVERSAL SCREENS

HOW TO SPECIFY

<p>Select Model Number</p> <p>H U V S T A H S P</p>	<p>Select Felt/Solid Core</p> <p>See pages 730-731</p> <p>D L F 1</p>
---	---

ACOUSTIC SOLUTIONS

Floor Screens

OPEN MARKET

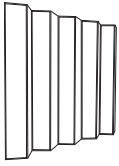

DESCRIPTION

MixMax
55"W x 59"H
63"W x 59"H

MODEL

HUVMF55
HUVMF63

SHIP WEIGHT

19.8
22.7

CUBE

24.4
24.4

LIST PRICE

\$3656
\$4039

NOTES:

- Available in one solid color. For multicolor options contact HON Tailored Solutions.
- Content: 100% 3mm Wool Felt exterior. 100% Foamed PVC Plate interior.
- Application: Floor Screen
- NRC: 0.80

UNIVERSAL SCREENS

HOW TO SPECIFY

Select
Model Number

Select
Fraster Felt

See pages 730-731

H U V M M F S 5 5 .

F F 1 3 0

ACOUSTIC SOLUTIONS Floor Screens

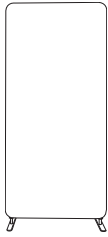

DESCRIPTION

Softline Floor Screen with Leg Set

32"W x 54"H
32"W x 59"H
32"W x 67"H

40"W x 54"H
40"W x 59"H
40"W x 67"H

47"W x 54"H
47"W x 59"H
47"W x 67"H

NOTES: Legs allow for screens to be freestanding.

Softline Floor Screen with Leg Set and Casters

32"W x 54"H
32"W x 59"H
32"W x 67"H

40"W x 54"H
40"W x 59"H
40"W x 67"H

47"W x 54"H
47"W x 59"H
47"W x 67"H

NOTES: Casters allow screens to be mobile.

MODEL

SHIP WEIGHT

CUBE

LIST PRICE

HUVSLFS3254L 25 12.5 **\$1313**
HUVSLFS3259L 30 12.5 **\$1536**
HUVSLFS3267L 35 12.5 **\$1696**

HUVSLFS4054L 27 10.4 **\$1463**
HUVSLFS4059L 33 10.4 **\$1650**
HUVSLFS4067L 38 10.4 **\$1818**

HUVSLFS4754L 30 7.8 **\$1585**
HUVSLFS4759L 36 7.8 **\$1765**
HUVSLFS4767L 43 7.8 **\$1907**

HUVSLFS3254LC 26 12.5 **\$1374**
HUVSLFS3259LC 31 12.5 **\$1596**
HUVSLFS3267LC 36 12.5 **\$1757**

HUVSLFS4054LC 28 10.4 **\$1524**
HUVSLFS4059LC 34 10.4 **\$1710**
HUVSLFS4067LC 39 10.4 **\$1879**

HUVSLFS4754LC 31 7.8 **\$1646**
HUVSLFS4759LC 37 7.8 **\$1826**
HUVSLFS4767LC 44 7.8 **\$1968**

NOTES:

- Softline is manufactured on the basis of technical, environmental, and production ethical requirements. There are no emissions to air, water, or land during the production of Softline. The sound-absorbent core of Softline contains recycled materials. Materials in Softline screens are recyclable, either as material recycling or energy recovery.
- Softline screens are 2" thick.
- Core Content: 100% Mineral Wool
- Frame Content: 100% Pine
- Base Content: 100% Steel lacquered in Black, Gray, or White
- Application: Floor Screen
- NRC: 0.75
- Each screen ships with one in-line connector.
- Screen legs prohibit screens from sitting directly at an L-, T-, or X-connection. Space must be provided to prevent legs from overlapping.

UNIVERSAL SCREENS

HOW TO SPECIFY

<p>Select Model Number</p> <p>H U V S L F S 4 0 5 4 L</p>	<p>Select Fabric</p> <p>See page 731</p> <p>S L 4 0</p>	<p>Select Paint Color</p> <p><i>Specify on screens with legs and legs with casters only</i></p> <p>SVR Silver WHTT White Texture BLKT Black Texture</p> <p>W H T T</p>
--	--	--

DESKTOP SCREENS ORDERING INFORMATION

DESKTOP PET

PET	CODES
◆ Dark Blue	DDB1
◆ Green	DGN1
◆ Dark Gray	DGY4
◆ Medium Gray	DGY3

EMPOWER® SCREEN BRACKETS

PAINTS	CODES
P1	
◆ Black	P71
◆ Brownstone	P7D
◆ Charcoal	S
◆ Designer White	PJW
◆ Fossil	P28
◆ Greige	T5
◆ Light Gray	Q
◆ Loft	LOFT
◆ Muslin	T3
◆ Putty	L
◆ Shadow *	SHDW
◆ Titanium	P8T
P2	
◆ Champagne Metallic	T4
◆ Platinum Metallic	T1
◆ Silver	PR6
◆ Solar Black	P8X
P3	
◆ Atom	P8S
◆ Bullseye	PJF
◆ Ember	P8P
◆ Ion	P8N
◆ Iris	P8J
◆ Krypton	P8F
◆ Regatta	P8M

GRAVITATION SCREEN BRACKETS

PAINTS	CODES
P1	
◆ Black	P71
◆ Brownstone	P7D
◆ Charcoal	P02
◆ Designer White	PJW
◆ Fossil	P28
◆ Greige	T5
◆ Light Gray	Q
◆ Loft	LOFT
◆ Muslin	T3
◆ Putty	L
◆ Shadow *	SHDW
◆ Titanium	P8T
P2	
◆ Champagne Metallic	T4
◆ Silver	PR6
◆ Solar Black	P8X
P3	
◆ Atom	P8S
◆ Bullseye	PJF
◆ Ember	P8P
◆ Ion	P8N
◆ Iris	P8J
◆ Krypton	P8F
◆ Regatta	P8M

◆◆◆ For lead time information see page 19.

* De-emphasized

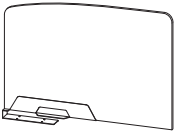
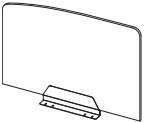
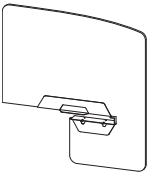
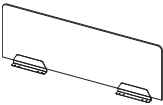
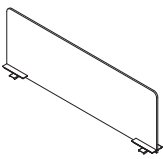

DESKTOP SCREENS

	DESCRIPTION	MODEL	SHIP WEIGHT	CUBE	LIST PRICE
	Coordinate™ Side/Middle Desktop PET Screens				
	23¼"W x 13"H	HUVDSSM1324	3.0	1.5	\$225
	29¼"W x 13"H	HUVDSSM1330	3.3	1.8	\$262
	23¼"W x 20"H	HUVDSSM2024	3.6	2.3	\$262
	29¼"W x 20"H	HUVDSSM2030	4.1	2.7	\$297
	Coordinate™ Side/End Desktop PET Screens				
	23¼"W x 13"H	HUVDSE1324	3.0	1.5	\$201
	29¼"W x 13"H	HUVDSE1330	3.0	1.8	\$237
	23¼"W x 20"H	HUVDSE2024	3.5	2.3	\$237
	29¼"W x 20"H	HUVDSE2030	4.1	2.7	\$279
NOTES: Screen attachment method involves screwing into the underside of the worksurface.					
	Coordinate™ Pacman PET Screens				
	23¼"W x 13"H, for 23"D Surfaces	HUVDPS1324	5.7	1.8	\$268
	29¼"W x 13"H, for 29"D Surfaces	HUVDPS1330	6.2	2.1	\$316
	23¼"W x 20"H, for 23"D Surfaces	HUVDPS2024	6.3	2.7	\$316
	29¼"W x 20"H, for 29"D Surfaces	HUVDPS2030	7.0	3.2	\$371
NOTES: Screen extends 6" from front of surface and 9" below surface.					
	Coordinate™ Above Desktop PET Screens				
	46"W x 13"H	HUVDSAO1348	5.0	2.7	\$378
	58"W x 13"H	HUVDSAO1360	5.6	3.3	\$419
	70"W x 13"H	HUVDSAO1372	6.2	4.0	\$466
	46"W x 20"H	HUVDSAO2048	6.2	4.1	\$472
	58"W x 20"H	HUVDSAO2060	7.1	5.0	\$524
	70"W x 20"H	HUVDSAO2072	8.0	5.9	\$582
NOTES: Screen attachment method involves screwing into the underside of the worksurface. Brackets can be positioned as needed to clear worksurface supports.					
	Empower® Desktop Screens				
	46"W x 13"H	HUVDSAOEM1348	5.0	2.7	\$378
	58"W x 13"H	HUVDSAOEM1360	5.6	3.3	\$419
	70"W x 13"H	HUVDSAOEM1372	6.2	4.0	\$466
	46"W x 20"H	HUVDSAOEM2048	6.2	4.1	\$472
	58"W x 20"H	HUVDSAOEM2060	7.1	5.0	\$524
	70"W x 20"H	HUVDSAOEM2072	8.0	5.9	\$582
NOTES: Specify PET and Bracket Paint, see page 736. P2 upcharge + \$4, P3 upcharge + \$20. Brackets can be positioned as needed to clear worksurface supports.					

UNIVERSAL SCREENS

NOTES:

- PET material is 12mm thick.
- Brackets painted in PR8 Silver.
- Brackets and screens ship in same box.
- PET material is tackable.

HOW TO SPECIFY

<p>Select Model Number</p> <p>H U V D S S M 1 3 3 0 .</p>	<p>Select PET Desktop</p> <p>See page 736</p> <p>D G Y 3 .</p>	<p>Select Paint Color</p> <p>PR6 Silver</p> <p>P R 6</p>
---	--	--

DESKTOP SCREENS

UNIVERSAL SCREENS

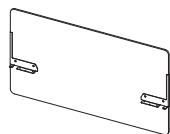

DESCRIPTION

Coordinate™ Above/Below PET Screens

46"W x 32"H, 13"H Above
58"W x 32"H, 13"H Above
70"W x 32"H, 13"H Above

46"W x 32"H, 20"H Above
58"W x 32"H, 20"H Above
70"W x 32"H, 20"H Above

MODEL

SHIP WEIGHT

CUBE

LIST PRICE

HUVDSHAB4813	9.7 Ⓞ	6.3	\$722
HUVDSHAB6013	11.0	7.7	\$802
HUVDSHAB7213	12.8	9.1	\$891
HUVDSHAB4820	9.7 Ⓞ	6.3	\$722
HUVDSHAB6020	11.0	7.7	\$802
HUVDSHAB7220	12.8	9.1	\$891

NOTES: Screen attachment method involves screwing into the underside of the worksurface.

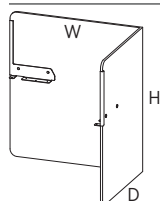

Coordinate™ Above/Below "L" PET Screens

23¼"D x 23"W x 32"H, 13"H Above, Right Hand
23¼"D x 29"W x 32"H, 13"H Above, Right Hand
23¼"D x 35"W x 32"H, 13"H Above, Right Hand

29¼"D x 23"W x 32"H, 13"H Above, Right Hand
29¼"D x 29"W x 32"H, 13"H Above, Right Hand
29¼"D x 35"W x 32"H, 13"H Above, Right Hand

23¼"D x 23"W x 32"H, 13"H Above, Left Hand
23¼"D x 29"W x 32"H, 13"H Above, Left Hand
23¼"D x 35"W x 32"H, 13"H Above, Left Hand

29¼"D x 23"W x 32"H, 13"H Above, Left Hand
29¼"D x 29"W x 32"H, 13"H Above, Left Hand
29¼"D x 35"W x 32"H, 13"H Above, Left Hand

HUVABLS2424R	9.2	6.3	\$830
HUVABLS3024R	9.9	7.0	\$876
HUVABLS3624R	9.9	7.7	\$922
HUVABLS2430R	10.6	6.3	\$1007
HUVABLS3030R	10.6	7.0	\$1060
HUVABLS3630R	10.6	7.7	\$1158
HUVABLS2424L	9.2	6.3	\$830
HUVABLS3024L	9.9	7.0	\$876
HUVABLS3624L	9.9	7.7	\$922
HUVABLS2430L	10.6	6.3	\$1007
HUVABLS3030L	10.6	7.0	\$1060
HUVABLS3630L	10.6	7.7	\$1158

NOTES: Screen attachment method includes screwing into the underside of the worksurface.

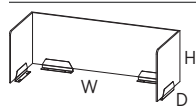

Coordinate™ Above "U" PET Screens

23¼"D x 46"W x 13"H
23¼"D x 58"W x 13"H
23¼"D x 70"W x 13"H

23¼"D x 46"W x 20"H
23¼"D x 58"W x 20"H
23¼"D x 70"W x 20"H

29¼"D x 46"W x 13"H
29¼"D x 58"W x 13"H
29¼"D x 70"W x 13"H

29¼"D x 46"W x 20"H
29¼"D x 58"W x 20"H
29¼"D x 70"W x 20"H

HUVAUS482413	12.0	4.0	\$932
HUVAUS602413	12.6	4.6	\$980
HUVAUS722413	13.2	5.2	\$1033
HUVAUS482420	14.5	5.9	\$1165
HUVAUS602420	15.4	6.8	\$1225
HUVAUS722420	16.3	7.7	\$1292
HUVAUS483013	12.6	4.0	\$1020
HUVAUS603013	13.2	4.6	\$1068
HUVAUS723013	13.7	5.2	\$1121
HUVAUS483020	15.4	5.9	\$1274
HUVAUS603020	16.3	6.8	\$1334
HUVAUS723020	17.1	7.7	\$1401

NOTES: Screen attachment method involves screwing into the underside of the worksurface.

ⓘ Screens are for use with Abound®, Accelerate®, Between™, Coordinate™, Empower®, Huddle, Motivate®, and Voi® only.

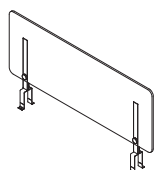

DESCRIPTION

Gravitation Beam PET Screen

46"W x 20"H
58"W x 20"H
70"W x 20"H

MODEL

SHIP WEIGHT

CUBE

LIST PRICE BY PAINT GRADE

P1

P2

P3

HUVDSBS2048	3.5 Ⓞ	4.1	\$472	\$476	\$492
HUVDSBS2060	4.4 Ⓞ	5.0	\$524	\$528	\$544
HUVDSBS2072	5.3 Ⓞ	5.9	\$582	\$586	\$602

NOTES: Specify PET and Bracket Paint, see page 736. Brackets and screen ship in separate boxes.

NOTES:

- PET material is 12mm thick.
- Brackets painted in PR8 Silver.
- Brackets and screens ship in same box except for Gravitation Beam PET Screens.
- PET material is tackable.

HOW TO SPECIFY

<p>Select Model Number</p> <p>H U V D S H A B 6 0 1 3 .</p>	<p>Select PET Desktop</p> <p>See page 736</p> <p>D G Y 3 .</p>	<p>Select Paint Color</p> <p>PR6 Silver</p> <p>P R 6</p>
---	--	--

UNIVERSAL SCREENS ORDERING INFORMATION

METAL TABLE SCREENS AND BRACKETS

PAINTS CODES

P1

◆ Black	P71
◆ Brownstone	P7D
◆ Charcoal	P02
◆ Designer White	PJW
◆ Fossil	P28
◆ Greige	T5
◆ Light Grey	Q
◆ Loft	LOFT
◆ Muslin	T3
◆ Putty	L
◆ Shadow *	SHDW
◆ Titanium	P8T

P2

◆ Champagne Metallic	T4
◆ Platinum Metallic	T1
◆ Silver	PR6
◆ Solar Black	P8X

P3

◆ Atom	P8S
◆ Blossom	P8K
◆ Bullseye	PJF
◆ Cabernet	P7T
◆ Conifer	P8H
◆ Ember	P8P
◆ Ion	P8N
◆ Iris	P8J
◆ Krypton	P8F
◆ Regatta	P8M
◆ Succulent	P8A

P6

◆ Markerboard	MKB
---------------------	-----

* De-emphasized

UNIVERSAL SCREENS

Table Screens

OPEN MARKET

ABI

Icon Legend on page 19

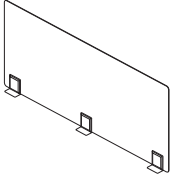
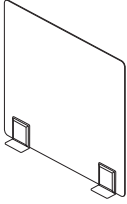
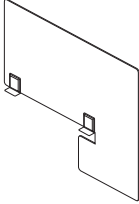
	DESCRIPTION	MODEL	SHIP WEIGHT	CUBE	LIST PRICE BY PAINT GRADE			
					P1	P2	P3	P6
	Metal Table Screen							
	20"H x 45½"W, for 48"W Surfaces	HMTLSCRN2048	36.4	5.5	\$643	\$663	\$683	\$743
	20"H x 51½"W, for 54"W Surfaces	HMTLSCRN2054	39.7	6.1	\$675	\$695	\$715	\$775
	20"H x 57½"W, for 60"W Surfaces	HMTLSCRN2060	43.1	6.7	\$710	\$730	\$750	\$810
	20"H x 63½"W, for 66"W Surfaces	HMTLSCRN2066	46.4	7.3	\$745	\$765	\$785	\$845
	25"H x 45½"W, for 48"W Surfaces	HMTLSCRN2548	42.8	6.7	\$707	\$727	\$747	\$807
	25"H x 51½"W, for 54"W Surfaces	HMTLSCRN2554	46.9	7.4	\$743	\$763	\$783	\$843
	25"H x 57½"W, for 60"W Surfaces	HMTLSCRN2560	51.1	8.2	\$780	\$800	\$820	\$880
	25"H x 63½"W, for 66"W Surfaces	HMTLSCRN2566	55.3	9.0	\$819	\$839	\$859	\$919
		Metal Lateral Screen						
20"H x 21"D, for 24"D Surfaces		HMTLSCRN2024	19.5	3.0	\$445	\$465	\$485	\$545
20"H x 25"D, for 27"-30"D Surfaces		HMTLSCRN2030	21.6	3.4	\$467	\$487	\$507	\$567
20"H x 36"D, for 36"D Surfaces		HMTLSCRN2036	26.6	4.3	\$490	\$510	\$530	\$590
25"H x 21"D, for 24"D Surfaces		HMTLSCRN2524	22.4	3.7	\$489	\$509	\$529	\$589
25"H x 25"D, for 30"D Surfaces		HMTLSCRN2530	25.0	4.2	\$514	\$534	\$554	\$614
25"H x 34"D, for 36"D Surfaces		HMTLSCRN2536	31.3	5.3	\$540	\$560	\$580	\$640
	Metal Extended Screen							
	20"H x 33½"D, for 24"D Surfaces	HMTLEXSCRN2036	61.2	5.7	\$591	\$611	\$631	\$691
	20"H x 37"D, for 30"D Surfaces	HMTLEXSCRN2042	65.9	6.3	\$621	\$641	\$661	\$721
	25"H x 33½"D, for 24"D Surfaces	HMTLEXSCRN2536	71.6	6.6	\$651	\$671	\$691	\$751
	25"H x 37"D, for 30"D Surfaces	HMTLEXSCRN2542	77.4	7.3	\$683	\$703	\$723	\$783

NOTES:

- Metal screens are single-piece steel construction.
- Screens mount by using double stick tape, which provides the ability to mount to any surface.
- Extended Screen can be used on all HON products including Voi®, Empower®, and Coordinate™ Height Adjustable Tables. Extended screen can also be used on any 2½" thick or under surface with 5"D clear space underneath.
- Minimum mounting clearance on top of worksurface at each bracket location is 3"W x 1½"D.

HOW TO SPECIFY

<p>Select Model Number</p> <p>HMTLSCRN2054</p>	<p>Select Frame Paint</p> <p>See page 739</p> <p>P8T</p>	<p>Select Bracket Paint</p> <p>NA No Specification Needed, matches Frame Paint</p> <p>NA</p>
--	--	--



UNIVERSAL SCREENS

Table Screens

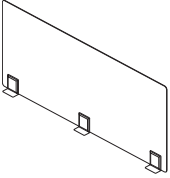
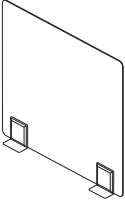
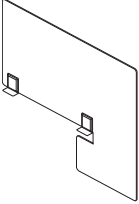
	DESCRIPTION	MODEL	SHIP WEIGHT	CUBE	LIST PRICE BY PAINT GRADE			
					P1	P2	P3	P6
	Acrylic Table Screen							
	20"H x 45½"W, for 48"W Surfaces	HACRYSCRN2048	8.0	5.5	\$579	\$591	\$597	N/A
	20"H x 51½"W, for 54"W Surfaces	HACRYSCRN2054	12.0	6.1	\$608	\$620	\$626	N/A
	20"H x 57½"W, for 60"W Surfaces	HACRYSCRN2060	14.0	6.7	\$638	\$650	\$656	N/A
	20"H x 63½"W, for 66"W Surfaces	HACRYSCRN2066	15.0	7.3	\$670	\$682	\$688	N/A
	25"H x 45½"W, for 48"W Surfaces	HACRYSCRN2548 ☹	15.0	6.7	\$637	\$649	\$655	N/A
	25"H x 51½"W, for 54"W Surfaces	HACRYSCRN2554 ☹	18.0	7.4	\$668	\$680	\$686	N/A
	25"H x 57½"W, for 60"W Surfaces	HACRYSCRN2560 ☹	20.0	8.2	\$702	\$714	\$720	N/A
	25"H x 63½"W, for 66"W Surfaces	HACRYSCRN2566 ☹	21.0	9.0	\$737	\$749	\$755	N/A
		Acrylic Lateral Screen						
20"H x 21"D, for 24"D Surfaces		HACRYSCRN2024	5.0	3.0	\$400	\$408	\$412	N/A
20"H x 25"D, for 27"-30"D Surfaces		HACRYSCRN2030	5.0	3.4	\$421	\$429	\$433	N/A
20"H x 36"D, for 36"D Surfaces		HACRYSCRN2036	6.0	4.3	\$442	\$450	\$454	N/A
25"H x 21"D, for 24"D Surfaces		HACRYSCRN2524 ☹	6.0	3.7	\$441	\$449	\$453	N/A
25"H x 25"D, for 30"D Surfaces		HACRYSCRN2530 ☹	8.0	4.2	\$462	\$470	\$474	N/A
25"H x 34"D, for 36"D Surfaces		HACRYSCRN2536 ☹	11.0	5.3	\$485	\$493	\$497	N/A
	Acrylic Extended Screen							
	20"H x 33½"D, for 24"D Surfaces	HACRYEXSCRN2036	7.0	5.7	\$533	\$541	\$545	N/A
	20"H x 37"D, for 30"D Surfaces	HACRYEXSCRN2042 ☹	9.0	6.3	\$559	\$567	\$571	N/A
	25"H x 33½"D, for 24"D Surfaces	HACRYEXSCRN2536	12.0	6.6	\$585	\$593	\$597	N/A
	25"H x 37"D, for 30"D Surfaces	HACRYEXSCRN2542	14.0	7.3	\$615	\$623	\$627	N/A

NOTES:

- Screens mount by using double stick tape, which provides the ability to mount to any surface.
- Extended Screen can be used on all HON products including Voi®, Empower®, and Coordinate™ Height Adjustable Tables. Extended screen can also be used on any 2½" thick or under surface with 5"D clear space underneath.
- Minimum mounting clearance on top of worksurface at each bracket location is 3"W x 1½"D.

HOW TO SPECIFY

<p>Select Model Number</p> <p>H A C R Y S C R N 2 0 5 4 .</p>	<p>Select Bracket Paint</p> <p>See page 739</p> <p>P 8 T</p>
---	--

UNIVERSAL SCREENS

Plexi-Glass Screens

OPEN MARKET



Icon Legend on page 19

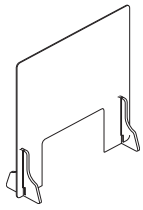

DESCRIPTION

Plexi-Glass Screens with Pass-Thru Opening

36''H x 30''W
36''H x 36''W
36''H x 48''W

MODEL

HHC-TASCRN3630 ⓘ
HHC-TASCRN3636 ⓘ
HHC-TASCRN3648

SHIP WEIGHT

13
15
19

CUBE

1.4
1.1
1.5

LIST PRICE

\$465
\$475
\$485

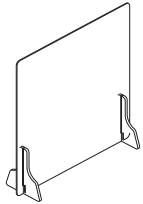

Plexi-Glass Screens without Pass-Thru Opening

24''H x 30''W
24''H x 36''W
24''H x 48''W

H-TASCRN2430
H-TASCRN2436
H-TASCRN2448

10
11
14

1.0
1.2
1.6

\$416
\$424
\$441

36''H x 30''W
36''H x 36''W
36''H x 48''W

H-TASCRN3630 ⓘ
H-TASCRN3636 ⓘ
H-TASCRN3648

13
15
19

1.4
1.1
1.5

\$465
\$475
\$485

NOTES:

- Screens ship with two black stands each.
- Screen stand is 11''D x 12''H.
- Pass-thru opening is 20''W x 12''H.

- ! Easy to assemble, no tools required.
- ! Unit is freestanding and does not need to be fixed to any surface.

UNIVERSAL SCREENS

HOW TO SPECIFY



Select
Model Number

HHC-TASCRN3636



UNIVERSAL SCREENS

Floor Screens

	DESCRIPTION	MODEL	SHIP WEIGHT	CUBE	LIST PRICE BY PAINT GRADE		
					P1	P2	P3
	Freestanding Acrylic Floor Screens						
	60"H x 36"W	HFHACRYSCRN6036	55	6.1	\$990	\$1006	\$1014
	60"H x 48"W	HFHACRYSCRN6048	60	8.0	\$1100	\$1116	\$1124
	72"H x 36"W	HFHACRYSCRN7236	62	7.4	\$1085	\$1101	\$1109
	72"H x 48"W	HFHACRYSCRN7248	65	9.6	\$1205	\$1221	\$1229
	<hr/>						
	Freestanding Twin-wall Polycarbonate Floor Screens						
	60"H x 48"W	HFHPCSCRN6048	62	8.0	\$825	\$841	\$849
	72"H x 48"W	HFHPCSCRN7248	65	9.6	\$900	\$916	\$924
	<hr/>						

NOTES:

- Screens ship in single cartons.
- Adjustable glides included.
- ! Screens are not made to accept casters.
- ! Twin-wall Polycarbonate is partially opaque, acrylic is clear.

HOW TO SPECIFY

<p>Select Model Number</p> <p>HFHACRYSCRN6048 .</p>	<p>Select Paint Color</p> <p>See page 739</p> <p>PR6</p>
---	--

UNIVERSAL SCREENS

Panel Stackers

OPEN MARKET



Icon Legend on page 19

UNIVERSAL SCREENS

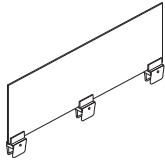

DESCRIPTION

Universal Panel Stackers

15"H x 22"W
15"H x 28"W
15"H x 34"W
15"H x 40"W
15"H x 46"W
15"H x 52"W
15"H x 58"W
15"H x 64"W
15"H x 70"W
15"H x 76"W
15"H x 82"W
15"H x 88"W
15"H x 94"W

MODEL

HPNLSTACK1524
HPNLSTACK1530
HPNLSTACK1536
HPNLSTACK1542
HPNLSTACK1548
HPNLSTACK1554
HPNLSTACK1560
HPNLSTACK1566
HPNLSTACK1572
HPNLSTACK1578
HPNLSTACK1584
HPNLSTACK1590
HPNLSTACK1596

SHIP WEIGHT

CUBE

LIST PRICE BY PAINT GRADE

P1 P2 P3

13.0 1.5 \$344 \$352 \$356
15.0 1.8 \$384 \$392 \$396
17.0 2.1 \$430 \$438 \$442
19.0 2.5 \$475 \$487 \$493
21.0 2.8 \$531 \$543 \$549
24.0 3.2 \$556 \$568 \$574
27.0 3.5 \$576 \$588 \$594
29.0 3.9 \$667 \$683 \$691
31.0 4.2 \$707 \$723 \$731
34.0 4.6 \$748 \$764 \$772
36.0 4.9 \$788 \$804 \$812
38.0 5.3 \$859 \$879 \$889
40.0 5.6 \$915 \$935 \$945

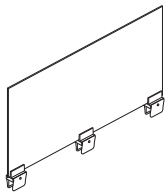

22"H x 22"W
22"H x 28"W
22"H x 34"W
22"H x 40"W
22"H x 46"W
22"H x 52"W
22"H x 58"W
22"H x 64"W
22"H x 70"W
22"H x 76"W
22"H x 82"W
22"H x 88"W
22"H x 94"W

HPNLSTACK2224 Ⓞ
HPNLSTACK2230 Ⓞ
HPNLSTACK2236 Ⓞ
HPNLSTACK2242 Ⓞ
HPNLSTACK2248 Ⓞ
HPNLSTACK2254 Ⓞ
HPNLSTACK2260 Ⓞ
HPNLSTACK2266
HPNLSTACK2272
HPNLSTACK2278
HPNLSTACK2284
HPNLSTACK2290
HPNLSTACK2296

17.0 1.9 \$388 \$396 \$400
20.0 2.4 \$434 \$442 \$446
23.0 2.9 \$485 \$493 \$497
26.0 3.3 \$537 \$549 \$555
29.0 3.8 \$599 \$611 \$617
32.0 4.3 \$629 \$641 \$647
35.0 4.7 \$651 \$663 \$669
38.0 5.2 \$754 \$770 \$778
41.0 5.6 \$799 \$815 \$823
44.0 6.1 \$845 \$861 \$869
47.0 6.6 \$890 \$906 \$914
50.0 7.0 \$971 \$991 \$1001
53.0 7.5 \$1034 \$1054 \$1064

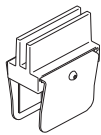

Universal Panel Stacker Bracket
1-Pack

HPNLSTACKBKT

2.5 Ⓞ

1.0

\$122

\$126

\$128

NOTES:

- Can be used on any panel system between 1.975" and 3.450" thick.
- Glass is undersized by 2".
- Stackers can span multiple panels.
- Panel stackers will work with both flat trim and radius trim.
- 1" gap between top cap and bottom of bracket.
- 6mm tempered glass.
- Cannot be used on top of glass stackers.

HOW TO SPECIFY

<p>Select Model Number</p> <p>HPNLSTACK2230</p>	<p>Select Glass</p> <p>G Glass</p> <p>G</p>	<p>Select Paint Color</p> <p>P</p>
<p>Select Model Number</p> <p>HPNLSTACKBKT</p>	<p>Select Paint Color</p> <p>P</p>	



CORE REMOVABLE LOCK KITS

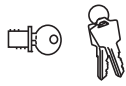

SIN 33721

DESCRIPTION

Chrome Removable Lock Core Kit (for metal casegoods)

• Use when specifying omit lock application.

- Specify quantity of each key number from 101E-225E.
- Includes: 1-core, 2-keys, 1-core removal tool and instructions.
- Removable lock core kits with specific key number must be ordered to facilitate keying alike in the field.
- For specific models, look for the Omit Lock Core icon throughout this publication.

NOTES: If key number isn't specified, number will be at random. Core matches manufactured lock on metal casegoods product but can be used with Contain® and laminate product.

MODEL

HF23C

SHIP WEIGHT

0.1 Ⓞ

CUBE

0.1

LIST PRICE

\$44

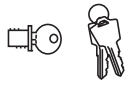

SIN 33721

Satin Removable Lock Core Kit (for metal and laminate casegoods)

• Use when specifying omit lock application.

- Specify quantity of each key number from 101E-225E.
- Includes: 1-core, 2-keys, 1-core removal tool and instructions.
- Removable lock core kits with specific key number must be ordered to facilitate keying alike in the field.
- For specific models, look for the Omit Lock Core icon throughout this publication.

NOTES: If key number isn't specified, number will be at random. Core matches manufactured lock on metal casegoods product but can be used with metal casegoods and laminate product. For laminate stack-on and wall mounted storage models with locks, use HF27S.

MODEL

HF23S

SHIP WEIGHT

0.1 Ⓞ

CUBE

0.1

LIST PRICE

\$42

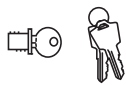

SIN 33721

Black Removable Lock Core Kit (for laminate products)

Specify quantity of each key number from 101E-225E.

Includes: 1-core, 2-keys, 1-core removal tool, and instructions.

NOTES: If key number isn't specified, number will be at random. Core matches manufactured lock on laminate product but can be used with metal casegoods product. For laminate stack-on and wall mounted storage models with locks, use HF27B.

MODEL

HF23B

SHIP WEIGHT

0.1 Ⓞ

CUBE

0.1

LIST PRICE

\$32

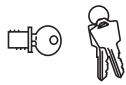

OPEN MARKET

Removable Lock Core Kit

Black

HF27B

0.2

0.02

\$32

Satin

HF27S

0.2

0.02

\$32

- For stack-on and wall mounted storage laminate models (with locks) in 10500, 10700, Valido, Voi, Concinnity, and 94000 Series.

- Specify quantity of each key number from 101E to 225E.
- Includes: 1-core, 2-keys, 1-core removal tool, and instructions.

NOTES: If key number isn't specified, number will be at random.



OPEN MARKET

Master Key (one key)

HF22

0.1 Ⓞ

0.1

\$26

Will open all HON product with HON "One Key" interchangeable core removable locks. Available to authorized dealers only. Will open HF23B, HF23C, HF23S, HF24, HF27B, and HF27S locks numbered 101E-225E. Will open old HON style MB series locks.



OPEN MARKET

Chrome Core Removable Lock Kit for Vertical Files

HF24

0.2 Ⓞ

0.2

\$60

Field Installable. Specify key number from 101E-225E. Includes: 1-lock with core, 2-keys and attaching linkage.

NOTES: If key number isn't specified, number will be at random.



OPEN MARKET

Bulk Package

6 HF24 Lock Kits (Individually shrink wrapped)

HF246

1.2 Ⓞ

0.2

\$279

NOTES: Bulk Package key numbers are at random and cannot be specified.

NOTES:

- HON "One Key" interchangeable core removable locks are standard on most HON products. Look for the HON "One Key" icon.
- Keyed alike cores are listed above.
- If key number is not specified, number will be at random.
- For keyed alike locks:
 - Order standard product which will be shipped with factory installed locks and random numbered cores or omit lock option where offered.
 - Order the appropriate quantity of like numbered cores required for each workstation or keyed area.
 - Simply replace the factory installed cores with the replacement cores after product has been installed.
- To install new core:
 - Lock must be in the unlocked position.
 - Insert core removal key and pull core straight out.
 - Insert new core with core removable key, hold core into lock and withdraw core removal key.
 - Retain original core for future use.
- To provide normal lead times, key numbers cannot be specified on HON products at time of order. This also eliminates need for tagging and tracking each product's lock number during installation.
- Black removable lock core kit used on laminate casegoods.
- Chrome removable lock core kit used on metal casegoods.



HOW TO ORDER CORE REMOVABLE LOCK KITS:

Specify: Model Number.X
Key Number

Examples: HF23C.X121E
HF23C.X (Key number not specified)

NOTES: Key orders without numbers specified will be keyed at random.
Numbers 101E-225E are available.

SAMPLE ORDER:

Quantity	Model	Key Code
6	HF23C.	X121E
4	HF23B.	X121E
5	HF24.	X121E
1	HF22.	X
2	HF24.	X

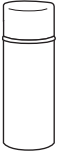

TOUCH-UP PAINT

	DESCRIPTION	MODEL	SHIP WEIGHT	CUBE	LIST PRICE BY PAINT GRADE		
					P1	P2	P3
	1 Touch-up Paint (.6 oz.) NOTES: Touch-up Paint available in P1, P2, and P3 colors.	HPMARKER1	0.1	0.1	\$66	\$73	\$84
	Spray Paint (12 oz.) NOTES: Touch-up Paint available in P1, P2, and P3 colors. ⓘ Designer White Texture (PK7) for use with Solve base only.	HSPRAY	0.5	0.1	\$66	\$73	\$84

NOTES:

- Allows minor repairs in the field.
- Shippable by small package carrier, ground only.
- Must specify color when ordering.

HOW TO SPECIFY

<p>Select Model Number</p> <p>HPMARKER1</p>	<p>Select Color</p> <p>See page 188 in the 2021 Shared Spaces Pricer</p> <p>P</p>
--	--

BUNDLES

What is a Bundled Solution?

A bundled solution is comprised of several individual components and is ordered with a single, all-encompassing number (SKU).

Why Bundles?

With bundles, you identify one SKU rather than multiple models/SKUs. Order one SKU and get everything you need!

How do you order a bundle?

Get everything in this picture with one number.

Still Prefer Ordering Individual Components?

You can do that! See the "bundle components" section for individual item SKUs.

Contemporary U-Station SKU

VC7292U1B

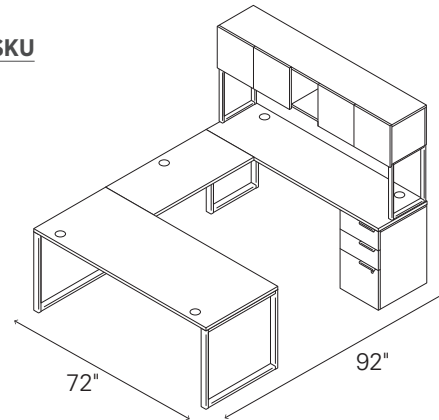

With this bundle you get the following components:

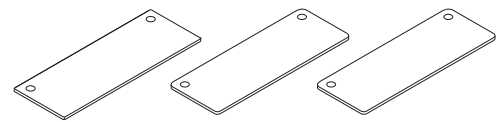

Rectangle Worksurfaces

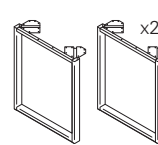

O-Leg Supports for Worksurfaces

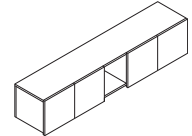

Overhead Cabinet with 4 Doors/Cubbie

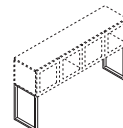

O-Leg Supports for Overhead Cabinet

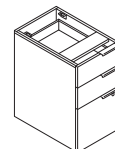

Support Pedestal

Availability

Specific bundle options are now available in the following HON Series:

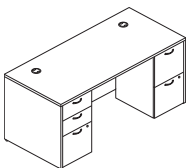

Mod

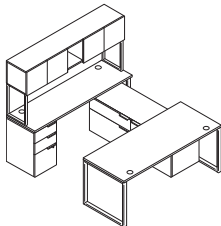

Voi

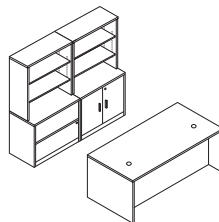

10500

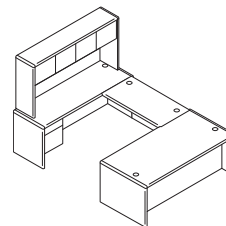

10700

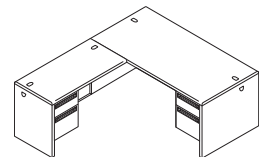

38000

MOD Bundles Typicals

Traditional Mahogany
HLPLDS72PSTM1

Sepia Walnut
HLPLDS72PSSE1

Java Oak
HLPLDS72PSJA1

Russet Cherry
HLPLDS72PSRC1

Slate Teak
HLPLDS72PSSL1

QTY	DESCRIPTION	MODEL	LIST PRICE	PRICE EXTENSION
1	Rectangular Desk Shell	HLPLDS7230	\$295	\$295
1	B/B/F Support Pedestal	HLPLPSBBF	\$311	\$311
1	F/F Support Pedestal	HLPLPSFF	\$311	\$311
TOTAL:			\$917	

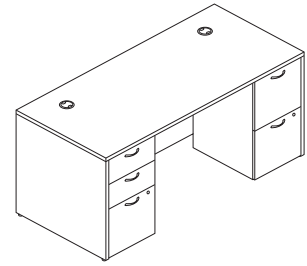

LAMINATE DESK WITH 2 PEDESTALS
72"W

Traditional Mahogany
HLPLDS66PSTM1

Sepia Walnut
HLPLDS66PSSE1

Java Oak
HLPLDS66PSJA1

Russet Cherry
HLPLDS66PSRC1

Slate Teak
HLPLDS66PSSL1

QTY	DESCRIPTION	MODEL	LIST PRICE	PRICE EXTENSION
1	Rectangular Desk Shell	HLPLDS6630	\$279	\$279
1	B/B/F Support Pedestal	HLPLPSBBF	\$311	\$311
1	F/F Support Pedestal	HLPLPSFF	\$311	\$311
TOTAL:			\$901	

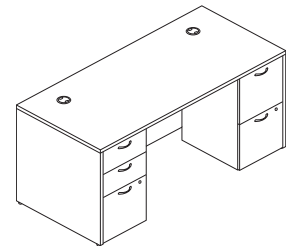

LAMINATE DESK WITH 2 PEDESTALS
66"W

Traditional Mahogany
HLPLDS60PSTM1

Sepia Walnut
HLPLDS60PSSE1

Java Oak
HLPLDS60PSJA1

Russet Cherry
HLPLDS60PSRC1

Slate Teak
HLPLDS60PSSL1

QTY	DESCRIPTION	MODEL	LIST PRICE	PRICE EXTENSION
1	Rectangular Desk Shell	HLPLDS6030	\$255	\$255
1	B/B/F Support Pedestal	HLPLPSBBF	\$311	\$311
TOTAL:			\$566	

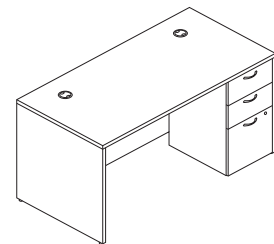

LAMINATE DESK WITH 1 PEDESTAL
60"W

Traditional Mahogany
HLPLDS48HBFM1

Sepia Walnut
HLPLDS48HBFSE1

Java Oak
HLPLDS48HBFJA1

Russet Cherry
HLPLDS48HBFRC1

Slate Teak
HLPLDS48HBFSL1

QTY	DESCRIPTION	MODEL	LIST PRICE	PRICE EXTENSION
1	Rectangular Desk Shell	HLPLDS4830	\$245	\$245
1	B/F Hanging Pedestal	HLPLPHBF	\$228	\$228
TOTAL:			\$473	

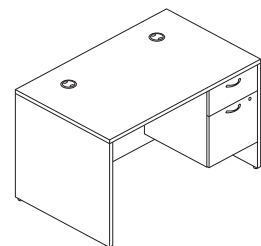

SMALL OFFICE DESK WITH 3/4 PEDESTAL
48"W

BUNDLES

MOD Bundles Typical

Black/Traditional Mahogany
HLPLW60LEG30UBLKPTM1

Black/Russet Cherry
HLPLW60LEG30UBLKPRC1

Black/Java Oak
HLPLW60LEG30UBLKPJA1

Black/Sepia Walnut
HLPLW60LEG30UBLKPSE1

Black/Slate Teak
HLPLW60LEG30UBLKPSL1

Black/Simply White
HLPLW60LEG30UBLKPPW1

Silver/Traditional Mahogany
HLPLW60LEG30USLVRTM1

Silver/Russet Cherry
HLPLW60LEG30USLVRR1

Silver/Java Oak
HLPLW60LEG30USLVRJA1

Silver/Sepia Walnut
HLPLW60LEG30USLVRSE1

Silver/Slate Teak
HLPLW60LEG30USLVRSL1

Silver/Simply White
HLPLW60LEG30USLVRPW1

QTY	DESCRIPTION	MODEL	LIST PRICE	PRICE EXTENSION
1	Rectangular Worksurface	HLPLRW6030	\$169	\$169
1	External Stiffener	HLPLXS60	\$65	\$65
2	U-Leg Support 30"W	HPLLEG30U	\$144	\$288
TOTAL:			\$522	

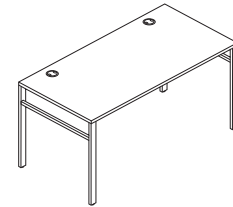

TABLE DESK WITH U-LEG
60"W x 30"D

Black/Traditional Mahogany
HLPLW66LEG30UBLKPTM1

Black/Russet Cherry
HLPLW66LEG30UBLKPRC1

Black/Java Oak
HLPLW66LEG30UBLKPJA1

Black/Sepia Walnut
HLPLW66LEG30UBLKPSE1

Black/Slate Teak
HLPLW66LEG30UBLKPSL1

Black/Simply White
HLPLW66LEG30UBLKPPW1

Silver/Traditional Mahogany
HLPLW66LEG30USLVRTM1

Silver/Russet Cherry
HLPLW66LEG30USLVRR1

Silver/Java Oak
HLPLW66LEG30USLVRJA1

Silver/Sepia Walnut
HLPLW66LEG30USLVRSE1

Silver/Slate Teak
HLPLW66LEG30USLVRSL1

Silver/Simply White
HLPLW66LEG30USLVRPW1

QTY	DESCRIPTION	MODEL	LIST PRICE	PRICE EXTENSION
1	Rectangular Worksurface	HLPLRW6630	\$179	\$179
1	External Stiffener	HLPLXS66	\$70	\$70
2	U-Leg Support 30"W	HPLLEG30U	\$144	\$288
TOTAL:			\$537	

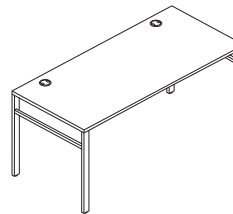

TABLE DESK WITH U-LEG
66"W x 30"D

MOD Bundles Typicals

Nickel/Traditional Mahogany
HLPLRW6024CONHATTM1

Nickel/Sepia Walnut
HLPLRW6024CONHATSE1

Nickel/Russet Cherry
HLPLRW6024CONHATRC1

Nickel/Slate Teak
HLPLRW6024CONHATSL1

Nickel/Java Oak
HLPLRW6024CONHATJA1

Nickel/Simply White
HLPLRW6024CONHATPW1

QTY	DESCRIPTION	MODEL	LIST PRICE	PRICE EXTENSION
1	Height Adjustable Base, 2-Stage	HHABETA2S2L	\$728	\$728
1	Rectangular Worksurface	HLPLRW6024	\$139	\$139
TOTAL:				\$867

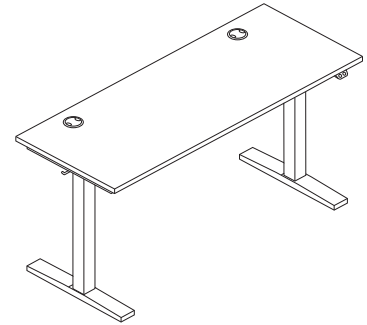

CONSUMER HEIGHT ADJUSTABLE TABLE
60"W x 24"D

Nickel/Traditional Mahogany
HLPLRW6030CONHATTM1

Nickel/Sepia Walnut
HLPLRW6030CONHATSE1

Nickel/Russet Cherry
HLPLRW6030CONHATRC1

Nickel/Slate Teak
HLPLRW6030CONHATSL1

Nickel/Java Oak
HLPLRW6030CONHATJA1

Nickel/Simply White
HLPLRW6030CONHATPW1

QTY	DESCRIPTION	MODEL	LIST PRICE	PRICE EXTENSION
1	Height Adjustable Base, 2-Stage	HHABETA2S2L	\$728	\$728
1	Rectangular Worksurface	HLPLRW6030	\$169	\$169
TOTAL:				\$897

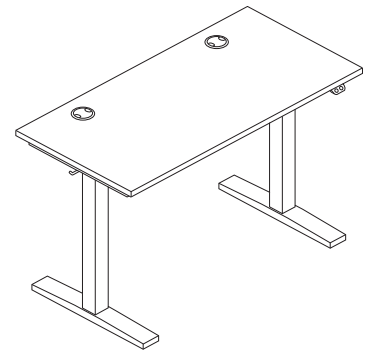

CONSUMER HEIGHT ADJUSTABLE TABLE
60"W x 30"D

Nickel/Traditional Mahogany
HLPLRW4824CONHATTM1

Nickel/Sepia Walnut
HLPLRW4824CONHATSE1

Nickel/Russet Cherry
HLPLRW4824CONHATRC1

Nickel/Slate Teak
HLPLRW4824CONHATSL1

Nickel/Java Oak
HLPLRW4824CONHATJA1

Nickel/Simply White
HLPLRW4824CONHATPW1

QTY	DESCRIPTION	MODEL	LIST PRICE	PRICE EXTENSION
1	Height Adjustable Base, 2-Stage	HHABETA2S2L	\$728	\$728
1	Rectangular Worksurface	HLPLRW4824	\$135	\$135
TOTAL:				\$863

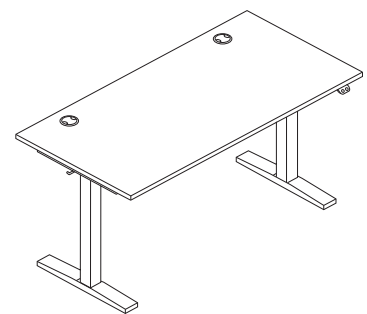

CONSUMER HEIGHT ADJUSTABLE TABLE
48"W x 24"D

BUNDLES

VOI® Bundles Typical

VT6030MB

Worksurface is Silver Mesh, Mobile Pedestal is Harvest, O-Leg Supports and grommets are Platinum Metallic.**

QTY	DESCRIPTION	MODEL	LIST PRICE	PRICE EXTENSION
1	Rectangle Worksurface with External Support Channel	HLSLR3060W*	\$484	\$484
2	O-Leg Support for Worksurface	HLSL3028O	\$563	\$1,126
1	Mobile Pedestal	HLSL2016MP2	\$813	\$813
TOTAL:			\$2,423	

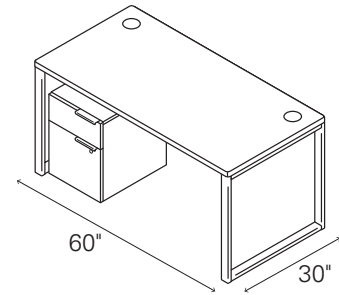
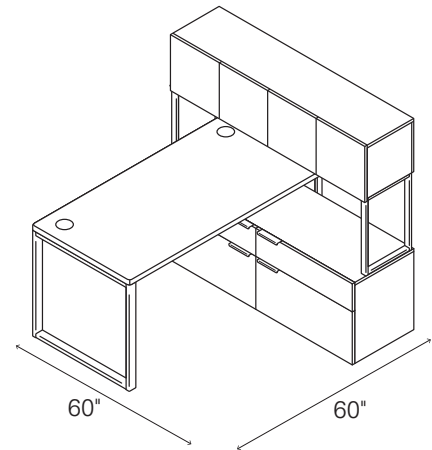

**TABLE DESK WITH MOBILE PEDESTAL
(NON-HANDED)**

VS6060L1B

Worksurface is Silver Mesh, Low Credenza and Overhead Cabinet are Harvest, O-Leg Supports and grommets are Platinum Metallic.**

QTY	DESCRIPTION	MODEL	LIST PRICE	PRICE EXTENSION
1	Rectangle Worksurface with External Support Channel	HLSLR3060W*	\$484	\$484
2	O-Leg Support for Worksurface	HLSL3028O	\$563	\$1,126
1	Low Credenza, 2 File/2 Box	HLSL2060LD4	\$1,500	\$1,500
1	Overhead Cabinet with 4 Doors	HLSL1460D	\$1,185	\$1,185
1	O-Leg Support for Overhead Cabinet (Pair)	HLSL650S	\$483	\$483
TOTAL:			\$4,778	



**SMALL FOOTPRINT L-STATION
(NON-HANDED)**

VS6060L6B

Worksurface is Silver Mesh, Low Credenza and Layering Shelf are Harvest, O-Leg Supports and grommets are Platinum Metallic.**

QTY	DESCRIPTION	MODEL	LIST PRICE	PRICE EXTENSION
1	Rectangle Worksurface with External Support Channel	HLSLR3060W*	\$484	\$484
2	O-Leg Support for Worksurface	HLSL3028O	\$563	\$1,126
1	Low Credenza, Right-hand Drawers	HLSL2060LR2	\$1,286	\$1,286
1	Layering Shelf	HLSL1460LS	\$372	\$372
TOTAL:			\$3,268	

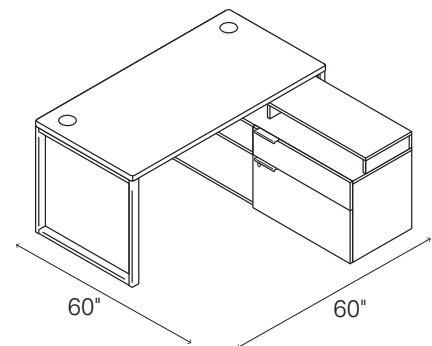

**SMALL FOOTPRINT L-STATION
(RIGHT HANDED, LOW CREDENZA)**

*Worksurface model **HLSLR3060W** can only be ordered with bundles.

**Platinum Metallic paint is a P2 upcharge.

VOI® Bundles Typicals

VS6060L4B

Worksurface is Silver Mesh, Low Credenza and Layering Shelf are Harvest, O-Leg Supports and grommets are Platinum Metallic.**

QTY	DESCRIPTION	MODEL	LIST PRICE	PRICE EXTENSION
1	Rectangle Worksurface with External Support Channel	HLSLR3060W*	\$484	\$484
2	O-Leg Support for Worksurface	HLSL30280	\$563	\$1,126
1	Low Credenza, Left-hand Drawers	HLSL2060LL2	\$1,286	\$1,286
1	Layering Shelf	HLSL1460LS	\$372	\$372
TOTAL:			\$3,268	

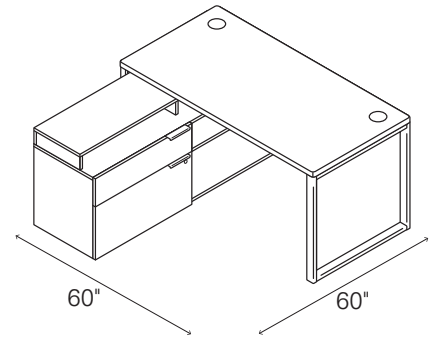

**SMALL FOOTPRINT L-STATION
(LEFT HANDED, LOW CREDENZA)**

VS6060L5B

Worksurface is Silver Mesh, Low Credenza and Overhead Cabinet are Harvest, O-Leg Supports and grommets are Platinum Metallic.**

QTY	DESCRIPTION	MODEL	LIST PRICE	PRICE EXTENSION
1	Rectangle Worksurface with External Support Channel	HLSLR3060W*	\$484	\$484
2	O-Leg Support for Worksurface	HLSL30280	\$563	\$1,126
1	Low Credenza, Right-hand Drawers	HLSL2060LR2	\$1,286	\$1,286
1	Overhead Cabinet with 4 Doors	HLSL1460D	\$1,185	\$1,185
1	O-Leg Support for Overhead Cabinet (Pair)	HLSL650S	\$483	\$483
TOTAL:			\$4,564	

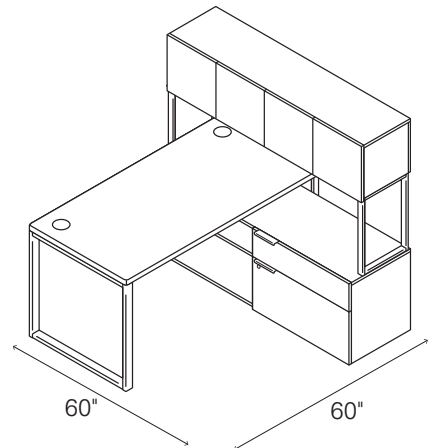

**SMALL FOOTPRINT L-STATION
(RIGHT HANDED, LOW CREDENZA)**

VS6060L3B

Worksurface is Silver Mesh, Low Credenza and Overhead Cabinet are Harvest, O-Leg Supports and grommets are Platinum Metallic.**

QTY	DESCRIPTION	MODEL	LIST PRICE	PRICE EXTENSION
1	Rectangle Worksurface with External Support Channel	HLSLR3060W*	\$484	\$484
2	O-Leg Support for Worksurface	HLSL30280	\$563	\$1,126
1	Low Credenza, Left-hand Drawers	HLSL2060LL2	\$1,286	\$1,286
1	Overhead Cabinet with 4 Doors	HLSL1460D	\$1,185	\$1,185
1	O-Leg Support for Overhead Cabinet (Pair)	HLSL650S	\$483	\$483
TOTAL:			\$4,564	

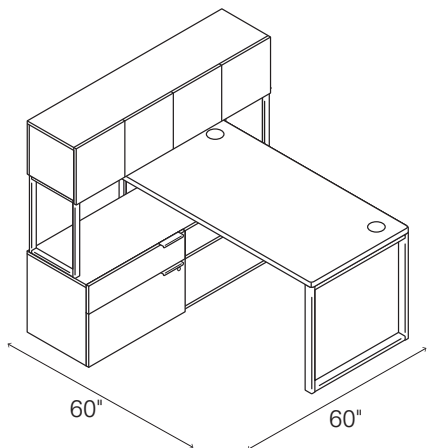

**SMALL FOOTPRINT L-STATION
(LEFT HANDED, LOW CREDENZA)**

*Worksurface model **HLSLR3060W** can only be ordered with bundles.

**Platinum Metallic paint is a P2 upcharge.

VOI® Bundles Typical

VS6060L2B

Worksurface is Silver Mesh, Low Credenza and Layering Shelf are Harvest, O-Leg Supports and grommets are Platinum Metallic.**

QTY	DESCRIPTION	MODEL	LIST PRICE	PRICE EXTENSION
1	Rectangle Worksurface with External Support Channel	HLSLR3060W*	\$484	\$484
2	O-Leg Support for Worksurface	HL30280	\$563	\$1,126
1	Low Credenza, 2 File/2 Box	HLSL2060LD4	\$1,500	\$1,500
1	Layering Shelf	HLSL1460LS	\$372	\$372
TOTAL:			\$3,482	

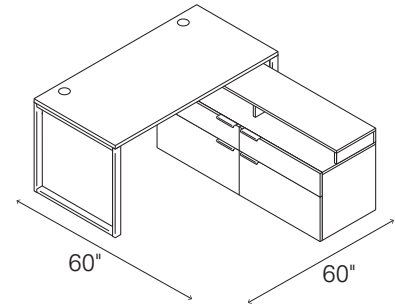

**SMALL FOOTPRINT L-STATION
(LOW CREDENZA, LAYERING SHELF)
(NON-HANDED)**

VC7260L2B

Worksurface is Silver Mesh, Low Credenza is Harvest, O-Leg Supports and grommets are Platinum Metallic.**

QTY	DESCRIPTION	MODEL	LIST PRICE	PRICE EXTENSION
1	Rectangle Worksurface with External Support Channel	HLSLR3072W*	\$562	\$562
2	O-Leg Support for Worksurface	HL30280	\$563	\$1,126
1	Low Credenza, 2 File/2 Box	HLSL2060LD4	\$1,500	\$1,500
TOTAL:			\$3,188	

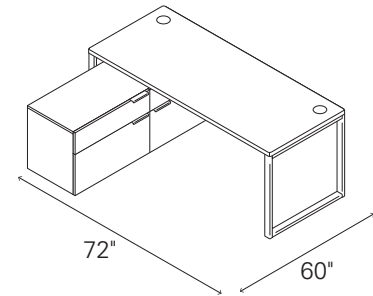

**CONTEMPORARY L-STATION
(NON-HANDED)**

*Worksurface models HLSLR3060W and HLSLR3072W can only be ordered with bundles.

**Platinum Metallic paint is a P2 upcharge.

10500 SERIES™ Bundles Typicals

Mahogany
H105LL7284N

Harvest
H105LL7284C

QTY	DESCRIPTION	MODEL	LIST PRICE	PRICE EXTENSION
1	Left Pedestal Desk	H10586L	\$1,182	\$1,182
1	Right Return	H10515R	\$837	\$837
TOTAL:			\$2,019	

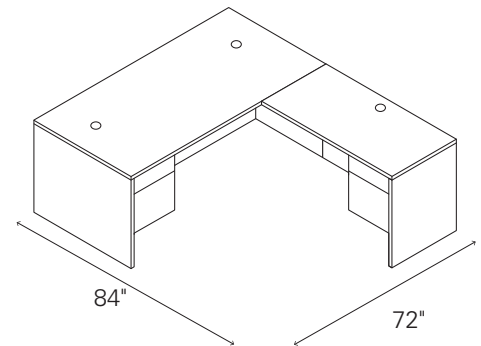

L-STATION (LEFT DESK/RIGHT RETURN)

Mahogany
H105LR7284N

Harvest
H105LR7284C

QTY	DESCRIPTION	MODEL	LIST PRICE	PRICE EXTENSION
1	Right Pedestal Desk	H10585R	\$1,182	\$1,182
1	Left Return	H10516L	\$837	\$837
TOTAL:			\$2,019	

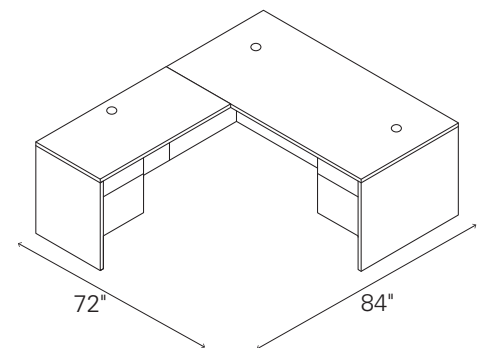

L-STATION (RIGHT DESK/LEFT RETURN)

Mahogany
H105LLH7284N

Harvest
H105LLH7284C

QTY	DESCRIPTION	MODEL	LIST PRICE	PRICE EXTENSION
1	Left Pedestal Desk	H10586L	\$1,182	\$1,182
1	Right Return	H10515R	\$837	\$837
1	Stack-on Storage	H105323	\$850	\$850
TOTAL:			\$2,869	

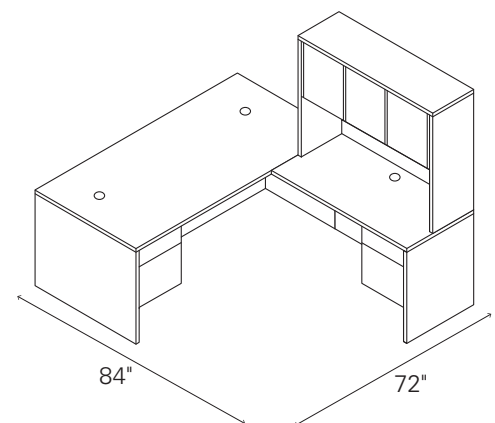

**L-STATION WITH STACK-ON STORAGE
(LEFT DESK/RIGHT RETURN)**

BUNDLES

10500 SERIES™ Bundles Typical

Mahogany
H105LRH7284N

Harvest
H105LRH7284C

QTY	DESCRIPTION	MODEL	LIST PRICE	PRICE EXTENSION
1	Right Pedestal Desk	H10585R	\$1,182	\$1,182
1	Left Return	H10516L	\$837	\$837
1	Stack-on Storage	H105323	\$850	\$850
TOTAL:			\$2,869	

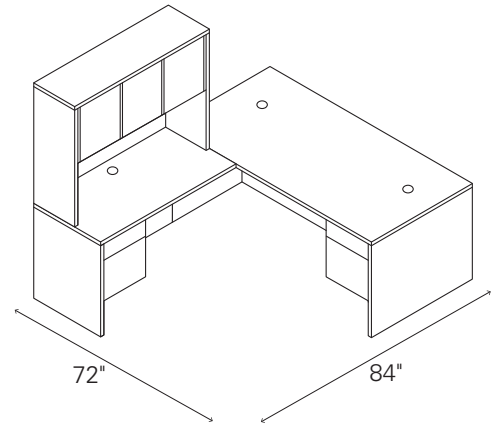

**L-STATION WITH STACK-ON STORAGE
(RIGHT DESK/LEFT RETURN)**

Mahogany
H105ULH72108N

Harvest
H105ULH72108C

QTY	DESCRIPTION	MODEL	LIST PRICE	PRICE EXTENSION
1	Left Pedestal Desk	H10586L	\$1,182	\$1,182
1	Right Pedestal Credenza	H10545R	\$1,023	\$1,023
1	Bridge	H10570	\$364	\$364
1	Stack-on Storage	H10534	\$1,011	\$1,011
TOTAL:			\$3,580	

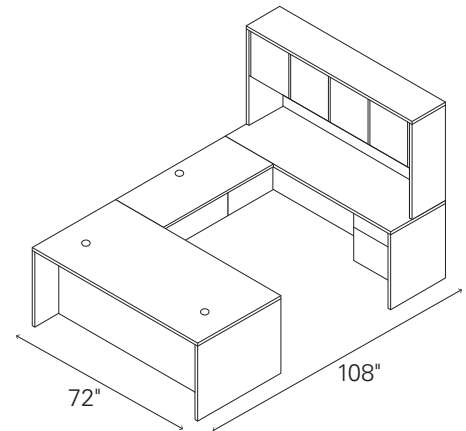

**U-STATION WITH STACK-ON STORAGE
(LEFT DESK/RIGHT CRENDENZA)**

Mahogany
H105URH72108N

Harvest
H105URH72108C

QTY	DESCRIPTION	MODEL	LIST PRICE	PRICE EXTENSION
1	Right Pedestal Desk	H10585R	\$1,182	\$1,182
1	Left Pedestal Credenza	H10546L	\$1,023	\$1,023
1	Bridge	H10570	\$364	\$364
1	Stack-on Storage	H10534	\$1,011	\$1,011
TOTAL:			\$3,580	

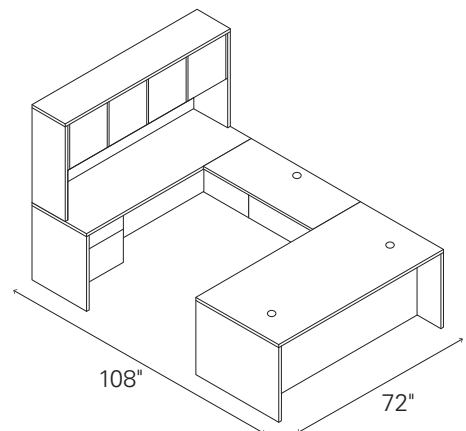

**U-STATION WITH STACK-ON STORAGE
(RIGHT DESK/LEFT CRENDENZA)**

10500 SERIES™ Bundles Typicals

Mahogany
H105DLH7298N

Harvest
H105DLH7298C

QTY	DESCRIPTION	MODEL	LIST PRICE	PRICE EXTENSION
1	Double Pedestal Desk	H10593	\$1,391	\$1,391
2	Bookcase Hutch	H105292	\$570	\$1,140
1	2-Drawer Lateral File	H10563	\$973	\$973
1	Storage Cabinet with Doors	H105291	\$781	\$781
TOTAL:			\$4,285	

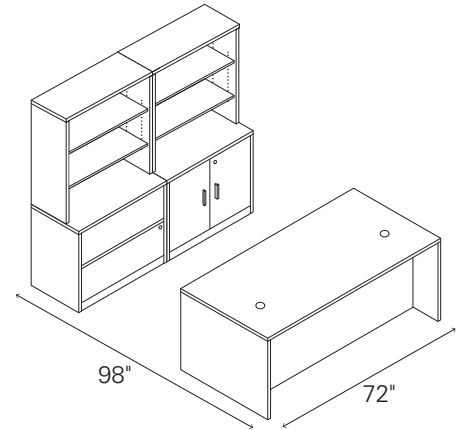

STORAGE WORKSTATION

Mahogany
H105DCH6098N

Harvest
H105DCH6098C

QTY	DESCRIPTION	MODEL	LIST PRICE	PRICE EXTENSION
1	Double Pedestal Desk	H10573	\$1,172	\$1,172
1	Double Pedestal Credenza	H10565	\$1,172	\$1,172
1	Stack-on Storage	H105324	\$943	\$943
TOTAL:			\$3,287	

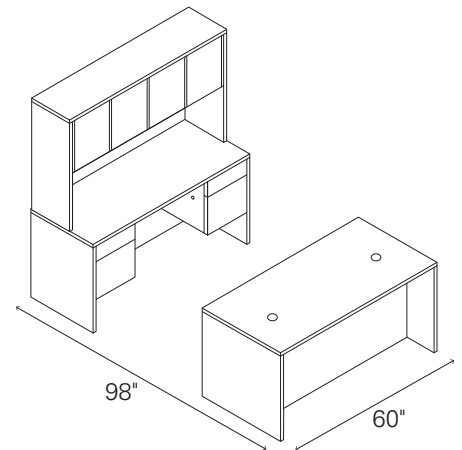

DESK CREDENZA STACK-ON #1

Mahogany
H105DCH7298N

Harvest
H105DCH7298C

QTY	DESCRIPTION	MODEL	LIST PRICE	PRICE EXTENSION
1	Double Pedestal Desk	H10593	\$1,391	\$1,391
1	Double Pedestal Credenza	H10543	\$1,240	\$1,240
1	Stack-on Storage	H10534	\$1,011	\$1,011
TOTAL:			\$3,642	

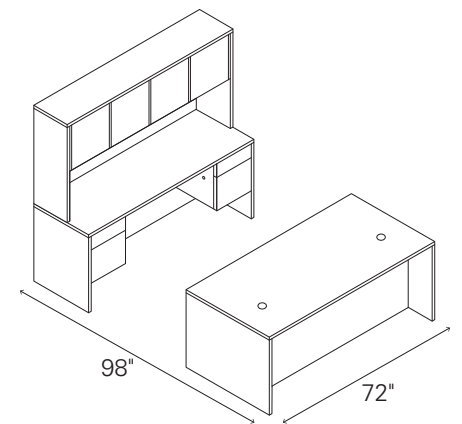

DESK CREDENZA STACK-ON #2

BUNDLES

10700 SERIES™

Bundles Typicals

Mahogany
H107LL7284N

QTY	DESCRIPTION	MODEL	LIST PRICE	PRICE EXTENSION
1	Left Pedestal Desk	H10786L	\$1,400	\$1,400
1	Right Return	H10715R	\$942	\$942
TOTAL:			\$2,342	

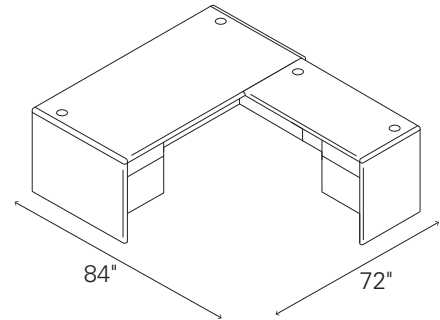

L-STATION (LEFT DESK, RIGHT RETURN)

Mahogany
H107LR7284N

QTY	DESCRIPTION	MODEL	LIST PRICE	PRICE EXTENSION
1	Right Pedestal Desk	H10785R	\$1,400	\$1,400
1	Left Return	H10716L	\$942	\$942
TOTAL:			\$2,342	

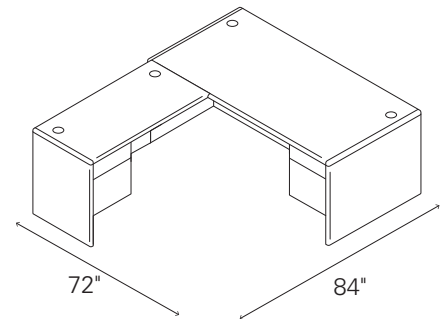

L-STATION (RIGHT DESK, LEFT RETURN)

Mahogany
H107UL72108N

QTY	DESCRIPTION	MODEL	LIST PRICE	PRICE EXTENSION
1	Left Pedestal Desk	H10786L	\$1,400	\$1,400
1	Right Pedestal Credenza	H10745R	\$1,228	\$1,228
1	Bridge	H10770	\$426	\$426
TOTAL:			\$3,054	

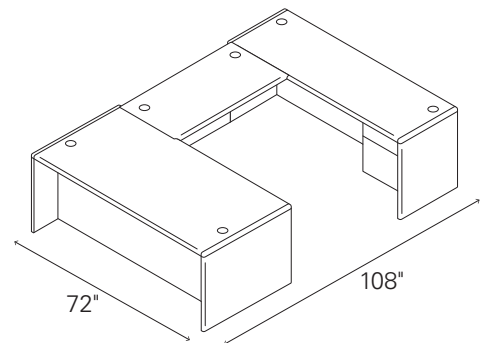

U-STATION (LEFT DESK, RIGHT CREDENZA)

10700 SERIES™ Bundles Typicals

Mahogany
H107UR72108N

QTY	DESCRIPTION	MODEL	LIST PRICE	PRICE EXTENSION
1	Right Pedestal Desk	H10785R	\$1,400	\$1,400
1	Left Pedestal Credenza	H10746L	\$1,228	\$1,228
1	Bridge	H10770	\$426	\$426
TOTAL:			\$3,054	

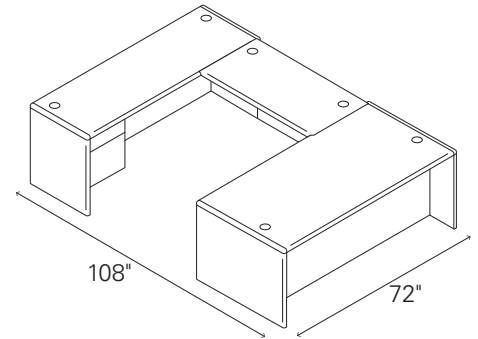

U-STATION (RIGHT DESK, LEFT CREDENZA)

Mahogany
H107LLH7284N

QTY	DESCRIPTION	MODEL	LIST PRICE	PRICE EXTENSION
1	Left Pedestal Desk	H10786L	\$1,400	\$1,400
1	Right Return	H10715R	\$942	\$942
1	Stack-on Storage	H107313	\$1,110	\$1,110
TOTAL:			\$3,452	

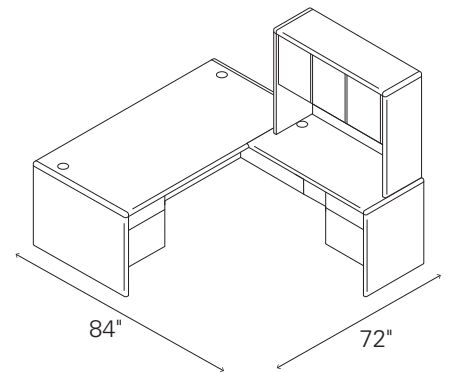

**L-STATION WITH STACK-ON STORAGE
(LEFT DESK, RIGHT RETURN)**

Mahogany
H107LRH7284N

QTY	DESCRIPTION	MODEL	LIST PRICE	PRICE EXTENSION
1	Right Pedestal Desk	H10785R	\$1,400	\$1,400
1	Left Return	H10716L	\$942	\$942
1	Stack-on Storage	H107313	\$1,110	\$1,110
TOTAL:			\$3,452	

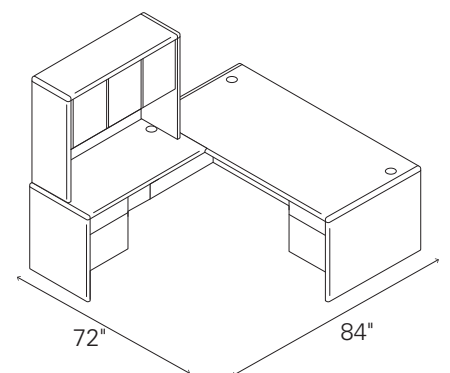

**L-STATION WITH STACK-ON STORAGE
(RIGHT DESK, LEFT RETURN)**

BUNDLES

10700 SERIES™

Bundles Typical

Mahogany
H107ULH72108N

QTY	DESCRIPTION	MODEL	LIST PRICE	PRICE EXTENSION
1	Left Pedestal Desk	H10786L	\$1,400	\$1,400
1	Right Pedestal Credenza	H10745R	\$1,228	\$1,228
1	Bridge	H10770	\$426	\$426
1	Stack-on Storage	H10734	\$1,259	\$1,259
TOTAL:			\$4,313	

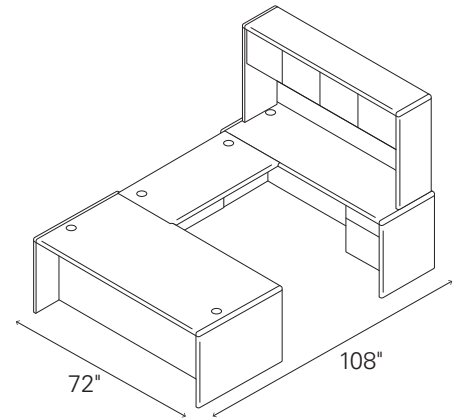

**U-STATION WITH STACK-ON STORAGE
(LEFT DESK, RIGHT CREDENZA)**

Mahogany
H107URH72108N

QTY	DESCRIPTION	MODEL	LIST PRICE	PRICE EXTENSION
1	Right Pedestal Desk	H10785R	\$1,400	\$1,400
1	Left Pedestal Credenza	H10746L	\$1,228	\$1,228
1	Bridge	H10770	\$426	\$426
1	Stack-on Storage	H10734	\$1,259	\$1,259
TOTAL:			\$4,313	

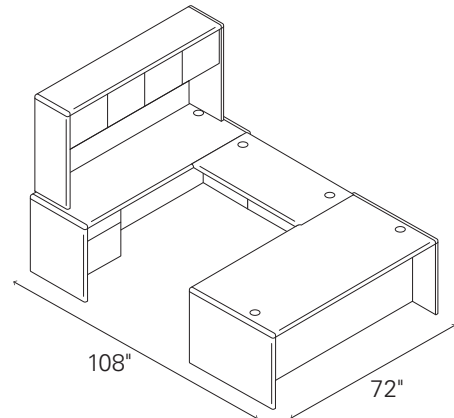

**U-STATION WITH STACK-ON STORAGE
(RIGHT DESK, LEFT CREDENZA)**

38000 SERIES™ Bundles Typicals

Mahogany/Charcoal
H38LL7284NS

Harvest/Putty
H38LL7284CL

QTY	DESCRIPTION	MODEL	LIST PRICE	PRICE EXTENSION
1	Left Pedestal Desk	H38294L	\$1,760	\$1,760
1	Right Return	H38215R	\$1,065	\$1,065
TOTAL:			\$2,825	

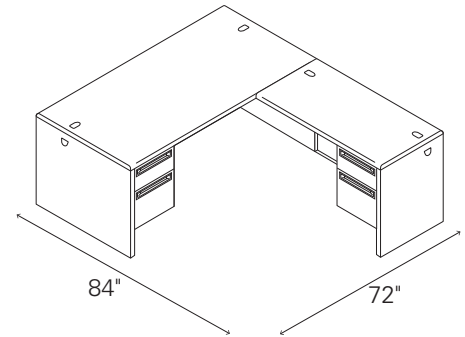

L-STATION (LEFT DESK/RIGHT RETURN)

Mahogany/Charcoal
H38LR7284NS

Harvest/Putty
H38LR7284CL

QTY	DESCRIPTION	MODEL	LIST PRICE	PRICE EXTENSION
1	Right Pedestal Desk	H38293R	\$1,760	\$1,760
1	Left Return	H38216L	\$1,065	\$1,065
TOTAL:			\$2,825	

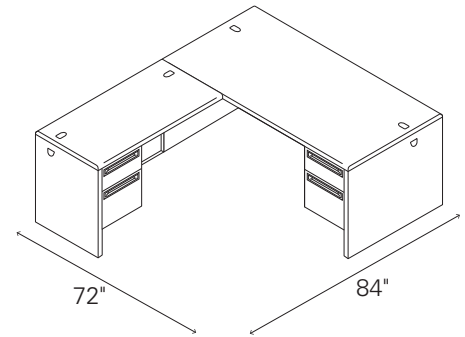

L-STATION (RIGHT DESK/LEFT RETURN)

Mahogany/Charcoal
H38URH72108NS2

Harvest/Putty
H38URH72108CL2

QTY	DESCRIPTION	MODEL	LIST PRICE	PRICE EXTENSION
1	Single Pedestal Desk, Right	H38293R	\$1,760	\$1,760
1	Single Pedestal Credenza, Left	H38855L	\$1,461	\$1,461
1	Hutch without Doors	H386572N	\$929	\$929
1	Flipper Doors, Pair	H387215	\$577	\$577
1	Bridge	H38210	\$593	\$593
TOTAL:			\$5,320	

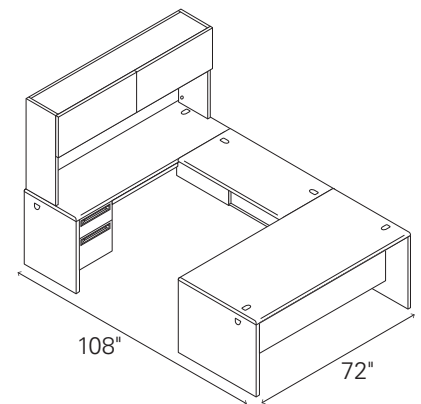

**U-STATION WITH HUTCH
(RIGHT DESK/LEFT CREDENZA)**

BUNDLES

38000 SERIES™

Bundles Typical

Mahogany/Charcoal
H38ULH72108NS2

Harvest/Putty
H38ULH72108CL2

QTY	DESCRIPTION	MODEL	LIST PRICE	PRICE EXTENSION
1	Single Pedestal Desk, Left	H38294L	\$1,760	\$1,760
1	Single Pedestal Credenza, Right	H38856R	\$1,461	\$1,461
1	Hutch without Doors	H386572N	\$929	\$929
1	Flipper Doors, Pair	H387215	\$577	\$577
1	Bridge	H38210	\$593	\$593
TOTAL:			\$5,320	

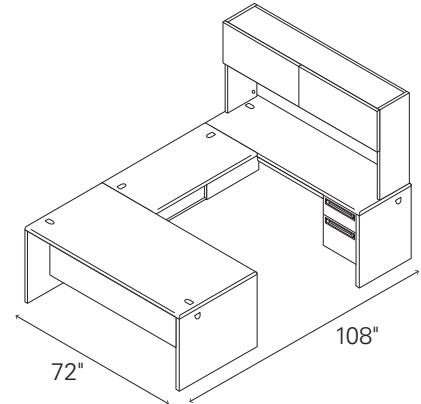

**U-STATION WITH HUTCH
 (LEFT DESK/RIGHT CREDENZA)**

Mahogany/Charcoal
H38DCH6096NS2

Harvest/Putty
H38DCH6096CL2

QTY	DESCRIPTION	MODEL	LIST PRICE	PRICE EXTENSION
1	Double Pedestal Desk	H38155	\$1,688	\$1,688
1	Double Pedestal Credenza	H38852	\$1,648	\$1,648
1	Hutch without Doors	H386560N	\$816	\$816
1	Flipper Doors, Pair	H386015	\$543	\$543
TOTAL:			\$4,695	

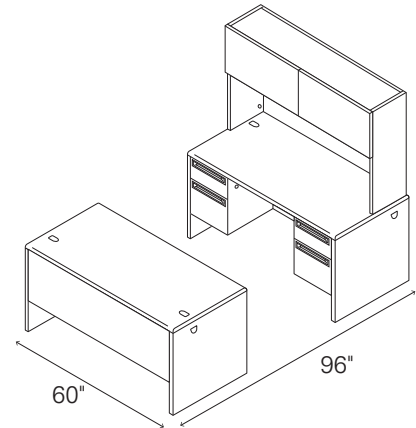

WORKSTATION

CROSS REFERENCE INDEX

MODEL	PAGE	MODEL	PAGE	MODEL	PAGE	MODEL	PAGE
H-TASCRN2430	742	H10530LEP	250	H10543	267	H105729	287
H-TASCRN2436	742	H10530TEP	250	H10544	267	H10573	266
H-TASCRN2448	742	H105310	282	H10545R	267	H10578	244
H-TASCRN3630	742	H105319	274	H10546L	267	H10578X	244
H-TASCRN3636	742	H105321	272	H10547R	270	H10579	244
H-TASCRN3648	742	H105321G	273	H10548L	270	H10579X	244
H10501	259, 310	H105321K	272	H105491	270	H105810	280
H105012	259	H105322	272	H105492	270	H105811	280
H105014	260	H105322G	273	H105493	270	H105815R	280
H10502	259, 310	H105322K	272	H105520	286	H105816L	280
H10503	261, 311	H105323	272	H105523	286	H105817R	280
H10504	260, 310	H105323G	273	H105524	286	H105818L	280
H10505	261, 311	H105323K	272	H105525R	286	H10583R	266
H105062	259	H105324	272	H105526L	286	H10584L	266
H105064	260	H105324G	273	H105527R	286	H105851	158, 275
H105076	261	H105324K	272	H105528L	286	H105852	158, 275
H105077	261	H105327	272	H105531	282	H105853	158, 275
H10508	261, 311	H105327G	273	H105532	286, 727	H105854	158, 275
H105093	259, 310	H105327K	272	H105533	286, 727	H105855	158, 275
H105098	145, 245, 307	H10533	272	H105534	286, 727	H105856	158, 275
H105099	145, 245, 307	H10533G	273	H105535	286, 727	H105857	158, 275
H1050CST	723	H10533K	272	H105581	245	H10585R	266
H105102	281, 320	H10534	272	H105581X	245	H10586L	266
H105104	281, 320	H105349	157, 273	H105582	245	H10587R	266
H105106	281, 320	H10534G	273	H105582X	245	H105885R	266
H105109	281, 320	H10534K	272	H105583	245	H10588L	266
H10511R	266	H10536	271	H105583X	245	H105890	262
H10512L	266	H105360	279	H105598	270	H105891	262
H10515R	266	H105361	279	H105599	270	H105892	262
H10516	281	H105362	279	H10560	270	H105893R	262
H10516L	266	H105363	279	H10561	248	H105894L	262
H10517	281	H105367	271	H10561X	248	H105895R	262
H105201R	268	H105368	271	H10563	281	H105896L	262
H105202L	268	H10537	271	H10564	245	H105897R	262
H105203R	268	H105380	276	H10564X	245	H105898L	262
H105204L	268	H105380G	279	H10565	267	H105899	262
H105205R	269	H105380K	276	H10566	267	H105900	263
H105206L	269	H105381	276	H105663	247	H105901	263
H105209	268	H105381G	279	H105679	148, 261, 311	H105902	263
H10521	268	H105381K	276	H10568	248	H105903R	263
H10522	268	H105382	276	H10568X	248	H105904L	263
H10523	268	H105382G	279	H105680	248	H105905R	263
H10524	260, 310	H105382K	276	H105680X	248	H105906L	263
H1052441LEP	250	H105383	276	H105681	248	H105907R	263
H10524LEP	250	H105383G	279	H105681X	248	H105908L	263
H10524TEP	250	H105383K	276	H105684	248	H105909	263
H10524TSUPP	250	H105386	271	H105684X	248	H10592	244
H10525R	268	H105388	271	H105686	248	H10592X	244
H10526L	268	H105392	247	H105686X	248	H10593	266
H10528	154, 269, 316	H105393	247	H105690	281	H10594	244
H105290	282	H105397	247	H105691	245	H10594X	244
H105291	282	H10541	245	H105691X	245	H10595	266
H105292	282	H105410	246	H105692	245	H10596	244
H105293	285	H105410X	246	H105692X	245	H10596X	244
H105295R	285	H105411	246	H105698	270	H105973R	263
H105296L	285	H105411X	246	H105699	270	H105974L	263
H105297R	285	H105412	246	H10570	270	H105975R	263
H105298L	285	H105412X	246	H10571	266	H105976L	263
H105299	285	H105413	246	H105720	287	H10598	244
H10530	285	H105413X	246	H105721	163, 287	H10598X	244
H105301R	285	H10541X	245	H105722	163, 287	H105B2460	249
H105302L	285	H10542	245	H105724	287	H105B3060	249
H1053041LEP	250	H10542X	245	H105726	287	H105B3066	249

CROSS REFERENCE INDEX

MODEL	PAGE	MODEL	PAGE	MODEL	PAGE	MODEL	PAGE
H105B3072	249	H105LT242450CBFL	283	H10717R	315	H107699	320
H105CT3020	265	H105LT242450CBFR	283	H10718L	315	H10770	317
H105CT3024	265	H105LT242450SBFL	283	H107191R	313	H10771	314
H105CT3620	265	H105LT242450SBFR	283	H107192L	313	H107720	323
H105CT3624	265	H105R2430	249	H107193R	315	H107721R	323
H105CTHAT3020	265	H105R2436	249	H107194L	315	H107722L	323
H105CTHAT3020L	265	H105R2442	249, 255	H10721	316	H107725R	308
H105CTHAT3620	265	H105R2448	249, 255, 602	H10722	316	H107726L	308
H105CTHAT3620R	265	H105R2460	249, 255, 602	H107242	323	H107727R	308
H105CTHAT3624L	265	H105R2466	249, 255, 602	H107270X	309	H107727RX	309
H105CTHAT3624R	265	H105R2472	249, 255, 602	H107290	320	H107728L	308
H105CTHAT6020L	265	H105R2478	249	H107291	320	H107728LX	309
H105CTHAT6020R	265	H105R2484	249	H107292	320	H10773	312
H105CTHAT6024L	265	H105R3048	249, 255, 602	H107293	322	H10774	312
H105CTHAT6024R	265	H105R3060	249, 255, 602	H107295R	322	H10775	314
H105CTHAT6620L	265	H105R3066	249, 255, 602	H107296L	322	H107801R	308
H105CTHAT6620R	265	H105R3072	249, 255, 602	H107299	322	H107801RX	309
H105CTHAT6624L	265	H105R3078	249	H10730	322	H107802L	308
H105CTHAT6624R	265	H105R3084	249	H107301R	322	H107802LX	309
H105CTHAT7220L	265	H105ST122450L	282	H107302L	322	H107803R	308
H105CTHAT7220R	265	H105ST122450R	282	H107313	318	H107803RX	309
H105CTHAT7224L	265	H105ST123050L	282	H107313K	318	H107804L	308
H105CTHAT7224R	265	H105ST123050R	282	H107318	318	H107804LX	309
H105HLEG2428	252	H105T2430C	269	H107318K	318	H107805R	308
H105HLEG2441	252	H105T3036C	269	H10732	318	H107805RX	309
H105HLEG3028	252	H105WMH30	277	H10732K	318	H107806L	308
H105HLEG3041	252	H105WMH30C	277	H10733	318	H107806LX	309
H105LC3020BF	264	H105WMH36	277	H10733K	318	H107807R	308
H105LC3020SF	264	H105WMH36C	277	H10734	318	H107807RX	309
H105LC3024BF	264	H105WMH42	277	H10734G	318	H107808L	308
H105LC3024SF	264	H105WMH42C	277	H10734K	318	H107808LX	309
H105LC3620BF	264	H105WMH48	277	H107353	319	H107811	317
H105LC3620SF	264	H105WMH48C	277	H107358	319, 337	H107815	307
H105LC3624BF	264	H105WMH48P	277	H10736	319	H107815X	307
H105LC3624SF	264	H105WMH48PC	277	H10737	319	H107816	307
H105LCHAT3020B	264	H105WMH48PCG	278	H10738	319, 337	H107816X	307
H105LCHAT3020S	264	H105WMH48PG	278	H107398	317	H107817	307
H105LCHAT3024S	264	H105WMH60P	277	H107399	317	H107817X	307
H105LCHAT3620B	264	H105WMH60PC	277	H10741	313	H107824	306
H105LCHAT3620S	264	H105WMH60PCG	278	H10742	313	H107825	306
H105LCHAT3624S	264	H105WMH60PG	278	H10743	315	H107825X	306
H105LT182050BFL	283	H105WMH66	277	H10744	315	H107826	306
H105LT182050BFR	283	H105WMH66C	277	H10745R	315	H107827	306
H105LT182050CBFL	283	H105WMH66P	277	H10746L	315	H107829	306
H105LT182050CBFR	283	H105WMH66PC	277	H10747R	317	H107835	307
H105LT182050SBFL	283	H105WMH66PCG	278	H10748L	317	H107836	307
H105LT182050SBFR	283	H105WMH66PG	278	H107492	317	H107837	307
H105LT182450BFL	283	H105WMH72P	277	H10751	317	H10783R	314
H105LT182450BFR	283	H105WMH72PC	277	H10752	321	H10784L	314
H105LT182450CBFL	283	H105WMH72PCG	278	H10753	321	H10785R	314
H105LT182450CBFR	283	H105WMH72PG	278	H10754	321	H10786L	314
H105LT182450SBFL	283	H10701R	312	H10755	321	H10787R	312
H105LT182450SBFR	283	H10702L	312	H107569	321	H10787RG	312
H105LT182450SCBFL	284	H10705R	313	H10760	317	H107885R	314
H105LT182450SCBFR	284	H10706L	313	H10762	320	H10788L	312
H105LT242050BFL	283	H10707R	313	H10763R	315	H10788LG	312
H105LT242050BFR	283	H10708L	313	H10764L	315	H10791	314
H105LT242050CBFL	283	H10709R	313	H10765	315	H10799	312
H105LT242050CBFR	283	H10710L	313	H10766	315	H10799G	312
H105LT242050SBFL	283	H10711R	313	H10767	313	H11501	147
H105LT242050SBFR	283	H10712L	313	H10768	313	H115012	147
H105LT242450BFL	283	H10715R	315	H107690	320	H115014	147
H105LT242450BFR	283	H10716L	315	H107698	320	H11502	147

CROSS REFERENCE INDEX

MODEL	PAGE	MODEL	PAGE	MODEL	PAGE	MODEL	PAGE
H11503	148	H115383	158	H115726	163	H19830(?)	680
H11504	147	H115383K	158	H11573	151	H20040AG	723
H11505	148	H11541	145	H11578	144	H212	717
H11508	148	H11541X	145	H11579	144	H212C	717
H115093	147	H11542	145	H115811	159	H214	717
H115102	160	H11542X	145	H115815R	159	H214C	717
H115104	160	H11543	152	H115816L	159	H215	717
H115106	160	H11544	152	H11583R	151	H215C	717
H115109	160	H11545R	152	H11584L	151	H312	718
H11511R	151	H11546L	152	H11585R	151	H312C	718
H11512L	151	H11547R	155	H11586L	151	H314	718
H11515R	151	H11548L	155	H11587R	151	H314C	718
H11516	160	H115491	155	H115885R	151	H315	718
H11516L	151	H115492	155	H11588L	151	H315C	718
H11517	160	H115493	155	H115890	149	H32	688
H115201R	153	H11552	162	H115891	149	H33720(?)	630
H115202L	153	H115520	162	H115892	149	H33723(?)	630
H115203R	153	H115523	162	H115893R	149	H33820(?)	630
H115204L	153	H115524	162	H115894L	149	H33823(?)	630
H11521	153	H115525R	162	H115895R	149	H34	688
H11522	153	H115526L	162	H115896L	149	H34002R	361
H11523	153	H115527R	162	H115897R	149	H34251	361
H11525R	153	H115528L	162	H115898L	149	H34480	361
H11526L	153	H11553	162	H115899	149	H34834R	361
H115290	160	H11554	162	H115900	150	H34835L	361
H115291	160	H11555	162	H115901	150	H34962	361
H115292	160	H115581	145	H115902	150	H34973R	361
H115293	161	H115581X	145	H115903R	150	H34974L	361
H115295R	161	H115582	145	H115904L	150	H36720(?)	630
H115296L	161	H115582X	145	H115905R	150	H36723(?)	630
H115297R	161	H115583	145	H115906L	150	H36820(?)	630
H115298L	161	H115583X	145	H115907R	150	H36823(?)	630
H115299	161	H115598	155	H115908L	150	H38155	372
H11530	161	H115599	155	H115909	150	H38170	372
H115301R	161	H11560	155	H11592	144	H38180	372
H115302L	161	H11561	146	H11593	151	H38210	374
H115321	156	H11561X	146	H11594	144	H38215R	372
H115321G	157	H11563	160	H11595	151	H38216L	372
H115321K	156	H11564	145	H11596	144	H38217R	372
H115322	156	H11564X	145	H11598	144	H38218L	372
H115322G	157	H11565	152	H14917(?)	680	H38220	374
H115322K	156	H11566	152	H14923(?)	680	H38251	372
H115323	156	H11568	146	H1522	106, 164, 228, 289, 326, 339	H38252L	372
H115323G	157	H115680	146	H1526	106, 164, 228, 289, 326, 339	H38291R	372
H115323K	156	H115680X	146	H15923(?)	543, 681	H38292L	372
H115324	156	H115681	146	H1801	728	H38293R	372
H115324G	157	H115681X	146	H1871	728	H38294L	372
H115324K	156	H115684	146	H18717(?)	680	H384815	378
H115327	156	H115684X	146	H1872	728	H386015	378
H115327G	157	H115686	146	H18723(?)	680	H386548N	354, 378
H115327K	156	H115686X	146	H18730(?)	680	H386560N	354, 378
H11533	156	H11568X	146	H1874	728	H386566N	354, 378
H11533G	157	H115690	160	H1875	728	H386572N	378
H11533K	156	H115691	145	H1876	728	H386615	378
H11534	156	H115691X	145	H1877	728	H387215	378
H11534G	157	H115692	145	H18817(?)	680	H38851	372
H11534K	156	H115692X	145	H18823(?)	680	H38852	372
H115380	158	H115698	155	H18830(?)	680	H38853	372
H115380K	158	H115699	155	H19717(?)	680	H38854	372
H115381	158	H11570	155	H19723(?)	680	H38855L	372
H115381K	158	H11571	151	H19730(?)	680	H38856R	372
H115382	158	H115720	163	H19817(?)	680	H38857L	372
H115382K	158	H115724	163	H19823(?)	680	H38858R	372

CROSS REFERENCE INDEX

MODEL	PAGE	MODEL	PAGE	MODEL	PAGE	MODEL	PAGE
H38921	373	H793	633	H919472	648, 649, 720	HAEHF	699
H38922	373	H794	633	H919491	720	HAELT	699
H38923	373	H795	633	H919492	720	HAESC19	697
H38925	373	H795LS	634	H9195(?)	682	HAESS	699
H38928	374	H80191	291	H94210	338	HAEST	699
H38931	373	H80192	291	H94211R	334	HAPGBP196NPT	695
H38932	373	H80193	291	H94212L	334	HAPGBP196NPTE	696
H38933	373	H872	631	H94215R	334	HAPGBP199TFN	695
H38934	373	H873	631	H94216L	334	HAPGBP199TFNE	696
H38935	373	H874	631	H94220	338	HAPGBP19SNPT	695
H38941	374	H875	631	H94221	338	HAPGBP19SNPTE	696
H38942	374	H875LS	632	H94222	338	HAPGBP236NPT	695
H38943R	373	H882	631	H94223	338	HAPGBP236NPTE	696
H38944L	373	H88231	346	H94224	338	HAPGBP239TFN	695
H38945R	373	H88235R	346	H94225	338	HAPGBP239TFNE	696
H38946L	373	H88236L	346	H94226	338	HAPGBS239TFN	695
H38947R	373	H88251R	345	H94229	338	HAPGBS239TFNE	696
H38948L	373	H88263R	345	H94234	336	HAPGBS23SNPT	695
H38949R	373	H88265R	345	H94234K	336	HAPGBS23SNPTE	696
H38950L	373	H88266L	345	H94235	337	HAPGCP199TPN	695
H38966	374	H883	631	H94236	336	HAPGCP199TPNE	696
H38SHFDV	379, 560	H884	631	H94237	336	HAPGCP239TPN	695
H4022	114, 164, 295, 327, 340, 374	H885	631	H94237K	336	HAPGCP239TPNE	696
H4028	114, 164, 295, 327, 374	H885LS	632	H94243	335	HAPGCS239TPN	695
H4029	114, 164, 295, 327, 374	H88962	345	H94244	335	HAPGCS239TPNE	696
H432	714	H88976	345	H94245R	335	HAPMAP196NFN	693
H434	714	H892	631	H94246L	335	HAPMAP196NFNE	694
H482	714	H893	631	H94247R	335	HAPMAP236NFN	693
H484	714	H894	631	H94248L	335	HAPMAP236NFNE	694
H511596	637	H895	631	H94251	334	HAPMBP196NPT	693
H512	719	H895LS	632	H94260	335	HAPMBP196NPTE	694
H51206	327, 374	H90031	319	H94270	335	HAPMBP199TFN	693
H512C	719	H90032	319	H94271	334	HAPMBP199TFNE	694
H514	719	H90033	319	H94276	334	HAPMBP19SNPT	693
H514C	719	H90034	319, 337	H94283R	334	HAPMBP19SNPTE	694
H519495	354, 361, 374, 723	H90035	319, 337	H94284L	334	HAPMBP236NPT	693
H52	688	H90050	59, 65, 275	H94285R	334	HAPMBP236NPTE	694
H52C	688	H90051	59, 65, 158, 275	H94286L	334	HAPMBP239TFN	693
H54	688	H90052	59, 65, 158, 275	H94291	338	HAPMBP239TFNE	694
H54C	688	H90053	59, 65, 158, 275	H94430	338	HAPMBS239TFN	693
H672	635	H90054	59, 65, 158, 275	H94435	338	HAPMBS239TFNE	694
H673	635	H90055	59, 65, 158, 275	H94720	339	HAPMBS23SNPT	693
H674	635	H90056	59, 65, 158, 275	H94721R	339	HAPMBS23SNPTE	694
H675	635	H90057	59, 65, 158, 275	H94722L	339	HAPMCP199TPN	693
H682	635	H9170(?)	682	HACRYEXSCRN2036	741	HAPMCP199TPNE	694
H683	635	H9173(?)	682	HACRYEXSCRN2042	741	HAPMCP239TPN	693
H684	635	H9174(?)	682	HACRYEXSCRN2536	741	HAPMCP239TPNE	694
H685	635	H9175(?)	682	HACRYEXSCRN2542	741	HAPMCS239TPN	693
H692	635	H9180(?)	682	HACRYSCRN2024	741	HAPMCS239TPNE	694
H693	635	H9183(?)	682	HACRYSCRN2030	741	HARCHA2	164, 292, 324
H694	635	H9184(?)	682	HACRYSCRN2036	741	HARCHA3	164, 292, 324
H695	635	H9185(?)	682	HACRYSCRN2048	741	HARCHC2	164, 292, 324
H772	633	H9185LS(?)	683	HACRYSCRN2054	741	HARCHC3	164, 292, 324
H773	633	H9185LSN(?)	683	HACRYSCRN2060	741	HAS18	638
H774	633	H9190(?)	682	HACRYSCRN2066	741	HAS24	638
H775	633	H9193(?)	682	HACRYSCRN2524	741	HAUFHL15N	698
H775LS	634	H9194(?)	682	HACRYSCRN2530	741	HAUFHL15NE	698
H782	633	H919430	648, 649, 720	HACRYSCRN2536	741	HAUFHR15N	698
H783	633	H919436	648, 649, 720	HACRYSCRN2548	741	HAUFHR15NE	698
H784	633	H919442	720	HACRYSCRN2554	741	HAUFO15N	698
H785	633	H919448	648, 649	HACRYSCRN2560	741	HB9	637
H785LS	634	H919460	648, 649, 720	HACRYSCRN2566	741	HBAFM2036	116, 171, 231, 297, 330, 342, 349, 357, 364, 377, 545, 618
H792	633	H919466	720	HAECBH	699		

CROSS REFERENCE INDEX

MODEL	PAGE	MODEL	PAGE	MODEL	PAGE	MODEL	PAGE
HBCKIT24	592	HBWCT4224P	505, 586	HEC42PXN	471	HEFG0766	470
HBCKIT30	592	HBWCT4230P	505, 586	HEC50P2N	471	HEFG0772	470
HBCKIT36	592	HBWCT4824P	505, 586	HEC50P3N	471	HEFG1520	470
HBCKIT24	592	HBWCT4830P	505, 586	HEC50PLN	471	HEFG1524	470
HBCKIT30	592	HBWD2450P	590	HEC50PSN	471	HEFG1530	470
HBCKIT36	592	HBWD3062P	590	HEC50PTN	471	HEFG1536	470
HBCKIT42	592	HBWQ2424P	590	HEC50PXN	471	HEFG1542	470
HBCKIT48	592	HBWQ3030P	590	HEC57P2N	471	HEFG1548	470
HBCKIT60	592	HBWQT2424P	590	HEC57P3N	471	HEFG1554	470
HBCKIT66	592	HBWQT3030P	590	HEC57PLN	471	HEFG1560	470
HBCKIT72	592	HBXRISER 115, 170, 230, 296, 329, 341,		HEC57PSN	471	HEFG1566	470
HBCSRI524P	591	348, 356, 363, 376, 617		HEC57PTN	471	HEFG1572	470
HBCSRI530P	591	HC14 354, 361		HEC57PXN	471	HEFTAC	474
HBCSRI536P	591	HCD1 164, 228, 295, 326, 340, 374, 616		HEC65P2N	471	HEOHRTA1524FD	551
HBCSRI542P	591	HCLA65 107, 166, 227, 295, 326, 613		HEC65P3N	471	HEOHRTA1530FD	551
HBCSRI548P	591	HCNLEG29 606		HEC65PLN	471	HEOHRTA1536FD	551
HBCSRI560P	591	HCOMDOME2 109, 169, 234, 347, 355,		HEC65PSN	471	HEOHRTA1542FD	551
HBCSRI566P	591	362, 375, 520, 576, 615		HEC65PTN	471	HEOHRTA1548FD	551
HBCSRI572P	591	HCPU1 166, 226, 544, 616		HEC65PXN	471	HEOHRTA1560FD	551
HBCSR2424P	591	HCRESCENTA2 292, 324		HEC72P2N	471	HEOHRTA1572FD	551
HBCSR3030P	591	HCRESCENTA3 292, 324		HEC72P3N	471	HEP35	574
HBCSR3636P	591	HCRESCENTC2 292, 324		HEC72PLN	471	HEP65	574
HBDMAUSB 115, 170, 226, 296, 329,		HCRESCENTC3 292, 324		HEC72PSN	471	HEPDMK42P	466
341, 348, 356, 363, 376, 617		HCS3636P 593		HEC72PTN	471	HERECPCVR	519, 574
HBEAFM1 116, 171, 231, 297, 330, 342,		HCS4242P 593		HEC72PXN	471	HESI520F	468
349, 357, 364, 377, 545, 618		HCTL181L 606		HEC80P2N	471	HESI520G	469
HBLPBRIDGE 133		HCTL181R 606		HEC80P3N	471	HESI524F	468
HBLPCLASSIC 133		HCTL182 606		HEC80PLN	471	HESI524G	469
HBLPCONTEMP 133		HCTL241L 606		HEC80PSN	471	HESI530F	468
HBMP2B 722		HCTL241R 606		HEC80PTN	471	HESI530G	469
HBMP2F 722		HCTL242 606		HEC80PXN	471	HESI536F	468
HBV-P4224 622		HCTROUGH17 109, 168, 233, 559, 577		HECB01 592		HESI536G	469
HBV-P4230 622		HCTROUGH1710 109, 168, 233, 559, 577		HECB42 592		HESI542F	468
HBV-P4236 622		HCTROUGH36 109, 168, 233, 559, 577		HECC10 560		HESI542G	469
HBV-P4242 622		HCTROUGH3610 109, 168, 233,		HECC15 560		HESI548F	468
HBV-P4248 622		559, 577		HECPP 574		HESI548G	469
HBV-P4260 622		HCWD2450P 590		HECPPI56 574		HESI560F	468
HBV-P4272 622		HCWD3062P 590		HECSI 472		HESI560G	469
HBV-P6024 622		HCWQ2424P 590		HECSL 472		HESI572F	468
HBV-P6030 622		HCWQ3030P 590		HECSS 472		HESI572G	469
HBV-P6036 622		HCWQT2424P 590		HECST 472		HES3020G	469
HBV-P6042 622		HCWQT3030P 590		HECSV 472		HES3024G	469
HBV-P6048 622		HD2 374		HECSX 472		HES3030G	469
HBV-P6060 622		HD8 374		HECSY 472		HES3036G	469
HBV-P6072 622		HDPS1 110, 165, 227, 290, 325		HECVH07P 473		HES3042G	469
HBV-P7224 622		HE4022 114, 164, 295, 327, 340		HECVH15P 473		HES3048G	469
HBV-P7230 622		HEABAC 474		HECVH22P 473		HES3060G	469
HBV-P7236 622		HEBPLATE336 467, 571		HECVH30P 473		HESDMK30	466
HBV-P7242 622		HEBPLATE342 467, 571		HEFEC35P 473		HESDMK36	466
HBV-P7248 622		HEBPLATE348 467, 571		HEFEC42P 473		HESDMK42	466
HBV-P7260 622		HEBPLATE360 467, 571		HEFEC50P 473		HESDMK48	466
HBV-PBS 623		HEBPLATE372 467, 571		HEFEC57P 473		HESHRTA24	551
HBV-PWB1 623		HEC35P2N 471		HEFEC65P 473		HESHRTA30	551
HBV-QC180 623		HEC35P3N 471		HEFEC72P 473		HESHRTA36	551
HBV-QC90 623		HEC35PLN 471		HEFEC80P 473		HESHRTA42	551
HBV-TBASE 623		HEC35PSN 471		HEFG0720 470		HESHRTA48	551
HBV-VSH24 623		HEC35PTN 471		HEFG0724 470		HESHRTA60	551
HBV-VSH30 623		HEC35PXN 471		HEFG0730 470		HESHRTA72	551
HBV-VSH36 623		HEC42P2N 471		HEFG0736 470		HETB2018	558
HBV-VSH42 623		HEC42P3N 471		HEFG0742 470		HETB2418	558
HBV-VSH48 623		HEC42PLN 471		HEFG0748 470		HETB3018	558
HBV-VSH60 623		HEC42PSN 471		HEFG0754 470		HETB3618	558
HBWCT3624P 505, 586		HEC42PTN 471		HEFG0760 470		HETB4218	558

CROSS REFERENCE INDEX

MODEL	PAGE	MODEL	PAGE	MODEL	PAGE	MODEL	PAGE
HETB4818	558	HETP6572FP	464	HH870960(?)	559	HH873501	575
HETB6018	558	HEVHF07P	473	HH870960CH	113, 337	HH873501A	575
HETB7218	558	HEVHF15P	473	HH871024	518, 572	HH873502	575
HETC20	467	HEVHF22P	473	HH871024A	518, 572	HH873502A	575
HETC24	467	HEVHF30P	473	HH871030	572	HH873503	575
HETC30	467	HEWS35P	473	HH871030A	572	HH873503A	575
HETC36	467	HEWS42P	473	HH871036	572	HH873504	575
HETC42	467	HEWS50P	473	HH871036A	572	HH873506	575
HETC48	467	HEWS57P	473	HH871042	572	HH879072	573
HETC60	467	HEWS65P	473	HH871042A	572	HH879072A	573
HETC66	467	HEWS72P	473	HH871048	518, 572	HH879168	573
HETC72	467	HEWS80P	473	HH871048A	518, 572	HH879168A	573
HETC78	467	HF22	723, 746	HH871060	518, 572	HH8988EBN	577
HETC84	467	HF23B	112, 164, 293, 326, 340, 746	HH871060A	518, 572	HHAB2S2L	198, 596
HETC90	467	HF23C	723, 746	HH871072	518, 572	HHAB3S2L	97, 198, 256, 596
HETC96	467	HF23S	112, 293, 649, 746	HH871124	572	HHAB3S3L	97, 198, 256, 596
HETP3520FP	464	HF24	721, 746	HH871124A	572	HHABCTRPK	598
HETP3524FP	464	HF246	721, 746	HH871130	572	HHABETA2S2L	594
HETP3530FP	464	HF27B	112, 293, 326, 746	HH871130A	572	HHABGLIDE	598
HETP3536FP	464	HF27S	112, 293, 746	HH871136	572	HHALGPT	452
HETP3542FP	464	HF50	721	HH871136A	572	HHALRECG	452
HETP3548FP	464	HF60	721	HH871142	572	HHALRECL	452
HETP3560FP	464	HF80	723	HH871142A	572	HHALRECR	452
HETP3572FP	464	HFHACRYSCRN6036	743	HH871148	518, 572	HHALRETL	452
HETP4220FP	464	HFHACRYSCRN6048	743	HH871148A	518, 572	HHALRETL	452
HETP4224FP	464	HFHACRYSCRN7236	743	HH871160	518, 572	HHALRETR	452
HETP4230FP	464	HFHACRYSCRN7248	743	HH871160A	518, 572	HHAW2448P	600
HETP4236FP	464	HFHPCSCRN6048	743	HH871172	518, 572	HHAW2448PN	507
HETP4242FP	464	HFHPCSCRN7248	743	HH871172A	518, 572	HHAW2454P	600
HETP4248FP	464	HFLDGRMT	108, 167, 294, 328	HH871224	572	HHAW2460P	600
HETP4260FP	464	HFLDGRMT3	108, 167, 233, 294, 328	HH871224A	572	HHAW2460PN	507
HETP4272FP	464	HFLDGRMT4	108	HH871230	572	HHAW2466P	600
HETP5020DP	465	HFMBIN12	684	HH871230A	572	HHAW2472P	600
HETP5020FP	464	HFMBIN3	684	HH871236	572	HHAW2472PN	507
HETP5024DP	465	HFMBIN6	684	HH871236A	572	HHAW2484PNS	599
HETP5024FP	464	HFMSC182830RWB	684	HH871242	572	HHAW2484PS	599
HETP5030DP	465	HFMSC183930RWB	684	HH871242A	572	HHAW2496PNS	599
HETP5030FP	464	HFMSC185230RWB	684	HH871248	518, 572	HHAW2496PS	599
HETP5036DP	465	HFMSC186430RWB	684	HH871248A	518, 572	HHAW3048P	600
HETP5036FP	464	HFSC183640(?)	686	HH871260	518, 572	HHAW3048PN	507
HETP5042DP	465	HFSC183640W	685	HH871260A	518, 572	HHAW3054P	600
HETP5042FP	464	HFSC183664(?)	686	HH871272	518, 572	HHAW3060P	600
HETP5048DP	465	HFSC183664W	685	HH871272A	518, 572	HHAW3060PN	507
HETP5048FP	464	HFTPD	598	HH871366	573	HHAW3066P	600
HETP5060DP	465	HGRMTAC	108, 168, 232, 294,	HH871366A	573	HHAW3072P	600
HETP5060FP	464		328, 577, 593	HH871400	519, 573	HHAW3072PN	507
HETP5072DP	465	HGRMTAC2	108, 168, 232,	HH871400A	519, 573	HHAW3084PNS	599
HETP5072FP	464		294, 328, 598	HH871500	519, 573	HHAW3084PS	599
HETP6520DP	465	HGRMTDATA	232	HH871501	519, 575	HHAW3096PNS	599
HETP6520FP	464	HGRMTUSB2	108, 168, 232,	HH871501A	519, 575	HHAW3096PS	599
HETP6524DP	465		294, 328, 577	HH871502	519, 575	HHAWD2450PN	507
HETP6524FP	464	HH15042SD	422, 466	HH871502A	519, 575	HHAWD3062PN	507
HETP6530DP	465	HH16542SD	422, 466	HH871503	519, 575	HHAWV603624LP	601
HETP6530FP	464	HH18042SD	422, 466	HH871503A	519, 575	HHAWV603624RP	601
HETP6536DP	465	HH870070	233, 574	HH871504	519, 575	HHAWV604824LP	601
HETP6536FP	464	HH870924(?)	559	HH871506	519, 575	HHAWV604824RP	601
HETP6542DP	465	HH870930	113, 167, 279	HH871601	519, 575	HHAWV604830LP	601
HETP6542FP	464	HH870930(?)	559	HH871601A	575	HHAWV604830RP	601
HETP6548DP	465	HH870930CH	113	HH871912	518, 573	HHAWV723624LP	601
HETP6548FP	464	HH870942	113, 167, 279, 327, 380	HH871912A	573	HHAWV723624RP	601
HETP6560DP	465	HH870942(?)	559	HH871918	573	HHAWV724824LP	601
HETP6560FP	464	HH870942CH	113	HH871918A	573	HHAWV724824RP	601
HETP6572DP	465	HH870960	113, 167, 279, 327, 337, 380	HH873500	573	HHAWV724830LP	601

CROSS REFERENCE INDEX

MODEL	PAGE	MODEL	PAGE	MODEL	PAGE	MODEL	PAGE
HHAVV724830RP	601	HLED17AS	113, 167, 225, 279, 327, 337, 380, 559	HLPLLEG30A	135	HLSL1220TS	204
HHC-TASCRN3630	742			HLPLLEG30U	135	HLSL1224FS	98, 205
HHC-TASCRN3636	742	HLED17AUO	113, 167, 225, 279, 327, 380, 559	HLPLLF3620L2	134	HLSL1224GS	98, 205
HHC-TASCRN3648	742			HLPLLF3620L3	134	HLSL1224TS	204
HHCMT24	577	HLED10C	113, 167, 229, 295, 327, 380, 614	HLPLLF3620L4	134	HLSL1230	98, 203, 258, 314
HHCMT36	577			HLPLOS10	135	HLSL1230FS	98, 205
HHEM620	577	HLED2	113, 167, 229, 295, 327, 380, 614	HLPLOS23	135	HLSL1230GS	98, 205
HHKDMK30	422	HLED31A	113, 167, 225, 279, 327, 380, 559	HLPLPEN6630	131	HLSL1230TS	204
HHKDMK36	422			HLPLPEN7236	131	HLSL1236	98, 203, 258, 314
HHKDMK42	422	HLED31AS	113, 167, 225, 279, 327, 337, 380, 559	HLPLPHBF	133	HLSL1236FS	98, 205
HHKDMK48	422			HLPLPMBBF	133	HLSL1236GS	98, 205
HHRMK36	558, 613	HLED31AUO	113, 167, 225, 279, 327, 380, 559	HLPLPMBF	133	HLSL1236TS	204
HHRMK42	558, 613			HLPLPMFF	133	HLSL1242	98, 203, 258, 314
HHRMK48	558, 613	HLEDOSA	113, 167, 225, 279, 327, 380, 559	HLPLPSBBF	133	HLSL1248	98, 203, 258, 314
HHN831118	606, 710			HLPLPSEAT1520	133	HLSL1254	98, 203, 258, 314
HHN831124	391, 598, 606	HLINEARA2	164, 292, 324	HLPLPSFF	133	HLSL1260	98, 203, 258, 314
HHN831130	391, 598, 606	HLINEARA3	164, 292, 324	HLPLRCPNDS7230	138	HLSL1336B2	224
HHPMC6	440, 466	HLINEARC2	164, 292, 324	HLPLRCPNRS4225	138	HLSL1336B3	224
HHPS1	110, 165, 227, 290, 325	HLINEARC3	164, 292, 324	HLPLRCPNTPGS	138	HLSL1336B4	224
HHT2DP	575	HLPLB3624	130	HLPLRCPNTPLM	138	HLSL1436BH	217
HHTADF3	577	HLPLB4224	130	HLPLRS3624	130	HLSL1436D	206, 555
HHTADF4	577	HLPLB4824	130	HLPLRS4224	130	HLSL1436S	206, 554
HHTADJ5	577	HLPLBC3013B2	134	HLPLRS4824	130	HLSL1442D	206, 555
HHTADJ6	577	HLPLBC3013B4	134	HLPLRW4824	135	HLSL1442S	206, 554
HICG12	421, 466	HLPLBC3013B5	134	HLPLRW4830	135	HLSL1448D	206, 555
HKBS	228, 616	HLPLCL3020BF	136	HLPLRW6024	135	HLSL1448S	206, 554
HKP2800	724	HLPLCL3020S	136	HLPLRW6030	135	HLSL1460D	206, 555
HLAM3348RR	68, 288	HLPLCL3020TOP	136	HLPLRW6624	135	HLSL1460LS	225
HLAM3772RD	68, 288	HLPLCL3620BF	136	HLPLRW6630	135	HLSL1460M	207, 556
HLAMMP6030	87, 258	HLPLCL3620S	136	HLPLRW7224	135	HLSL1460S	206, 554
HLAMMP7230	87, 258	HLPLCL3620TOP	136	HLPLRW7230	135	HLSL1466D	206, 555
HLAMSEAT3024	265	HLPLCL6020TOP	136	HLPLSC3620	134	HLSL1466M	207, 556
HLAMSEAT3624	265	HLPLCL6620TOP	136	HLPLSL24	135	HLSL1466S	206, 554
HLAMSHB30	97, 256	HLPLCL7220TOP	136	HLPLSL30	135	HLSL1472D	206, 555
HLCPL29WFH-PS	119	HLPLCS30	131	HLPLTACK48	132	HLSL1472DB	210
HLCPL29WFH-US	119	HLPLCS36	131	HLPLTACK60	132	HLSL1472LS	225
HLCPL29WFH	119	HLPLCS4824	130	HLPLTACK66	132	HLSL1472M	207, 556
HLCR2442WFH	119	HLPLCS6024	130	HLPLTACK72	132	HLSL1472MB	207
HLCR2448WFH	119	HLPLCS6624	130	HLPLTBL120BASE	137	HLSL1472S	206, 554
HLCR2454WFH	119	HLPLCS7224	130	HLPLTBL3672RCT	137	HLSL1472SB	210
HLCR3048WFH	119	HLPLCSEAT3020	136	HLPLTBL36BASE	137	HLSL140SPL	208, 557
HLCR3054WFH	119	HLPLCSEAT3620	136	HLPLTBL36RND	137	HLSL1512L SCL	218
HLCRPL4224WFH-PS	118	HLPLDH60	132	HLPLTBL4296RCT	137	HLSL1512LSCR	218
HLCRPL4224WFH-US	118	HLPLDH66	132	HLPLTBL42BASE	137	HLSL1512LSO	218
HLCRPL4224WFH	118	HLPLDH72	132	HLPLTBL42RND	137	HLSL1530SOMB	106, 208, 557
HLCRPL4824WFH-PS	118	HLPLDR12MB	132	HLPLTBL48120RCT	137	HLSL1536SOMB	106, 208, 557
HLCRPL4824WFH-US	118	HLPLDR48GS	132	HLPLTBL48BASE	137	HLSL154LSD	218
HLCRPL4824WFH	118	HLPLDR48LM	132	HLPLTBL48RND	137	HLSL154LSO	218
HLCRPL4830WFH-PS	118	HLPLDR60GS	132	HLPLTBL72BASE	137	HLSL1760SOL	208, 557
HLCRPL4830WFH-US	118	HLPLDR60LM	132	HLPLTBL96BASE	137	HLSL1760SOR	208, 557
HLCRPL4830WFH	118	HLPLDR66GS	132	HLPLW1824	134	HLSL1772SOL	208, 557
HLCRPL5424WFH-PS	118	HLPLDR66LM	132	HLPLW2424	134	HLSL1772SOR	208, 557
HLCRPL5424WFH-US	118	HLPLDR72GS	132	HLPLWMH48	132	HLSL2016FP2	223
HLCRPL5424WFH	118	HLPLDR72LM	132	HLPLWMH60	132	HLSL2016MP2	216, 523
HLCRPL5430WFH-PS	118	HLPLDS4830	130	HLPLWMH66	132	HLSL2016PH2	71, 216, 523
HLCRPL5430WFH-US	118	HLPLDS6030	130	HLPLWMH72	132	HLSL2020TS	204
HLCRPL5430WFH	118	HLPLDS6630	130	HLPLXS60	135	HLSL2024TS	204
HLCWFH-PS	119	HLPLDS7230	130	HLPLXS66	135	HLSL2028B	199, 611
HLCWFH-US	119	HLPLDS7236	130	HLPLXS72	135	HLSL2028E	194
HLDST1	110, 165, 227, 289, 325	HLPLDS7236B	130	HLSL1212	110, 165, 209, 225, 290, 325, 347, 355, 362, 375, 556	HLSL2028F	199, 611
HLED1	113, 167, 229, 295, 327, 380, 614	HLPLFB24	135			HLSL2028O	193, 604
HLED17A	113, 167, 225, 279, 327, 380, 559	HLPLLEG24A	135	HLSL1220FS	205	HLSL2028SL	193
		HLPLLEG24U	135	HLSL1220GS	205		

CROSS REFERENCE INDEX

MODEL	PAGE	MODEL	PAGE	MODEL	PAGE	MODEL	PAGE
HLSL2030CH2	50, 71, 212, 216, 265, 521, 522, 523	HLSL2441SL	94, 195, 253, 609	HLSL7235TS	204	HLSLW086L	221, 525
		HLSL2472LC	217	HLSL7265TE	210	HLSLW086R	221, 525
HLSL2030LDO	215, 522	HLSL247O	94, 193, 212, 254	HLSL72TW	207, 209	HLSLW1224L	196
HLSL2030LDOF	213	HLSL247SL	193	HLSL78TW	207, 209	HLSLW1224R	196
HLSL2030LD1	215, 522	HLSL24OBC	200, 612	HLSLDRWORG	225	HLSLW1230L	196
HLSL2030LD1F	213	HLSL2814LM	88, 201	HLSLPBL	194, 604	HLSLW1230R	196
HLSL2030LD2	215, 522	HLSL2828LM	88, 201	HLSLPBR	194, 604	HLSLW445L	220, 524
HLSL2030LD2F	213	HLSL2830	98, 203, 597	HLSLPMB	556	HLSLW445LF	222
HLSL2030MCO	216, 523	HLSL2836	98, 203, 597	HLSLPMBSO42	208, 557	HLSLW445R	220, 524
HLSL2030TS	204	HLSL2842	98, 203, 597	HLSLPMBSOA	208, 557	HLSLW445RF	222
HLSL2036CH2	50, 212, 265, 521, 522	HLSL2848	98, 203, 597	HLSLPMBSOB	208, 557	HLSLW446L	220, 524
HLSL2036L2	217	HLSL2854	98, 203, 597	HLSLR1330	209, 218	HLSLW446LP	220, 524
HLSL2036L4	217	HLSL2860	98, 203, 597	HLSLR1336	209, 218	HLSLW446R	220, 524
HLSL2036LDO	215, 522	HLSL28AM2	194	HLSLR1345	209, 218	HLSLW446RP	220, 524
HLSL2036LDOF	213	HLSL28AW2	194	HLSLR2036	189	HLSLW485L	221, 525
HLSL2036LD1	215, 522	HLSL28P	47, 95, 194, 251, 606	HLSLR2042	189	HLSLW485LF	222
HLSL2036LD1F	213	HLSL3014L	87, 201, 257, 603	HLSLR2048	189	HLSLW485R	221, 525
HLSL2036LD2	215, 522	HLSL3014MM	87, 202, 258, 603	HLSLR2054	189	HLSLW485RF	222
HLSL2036LD2F	213	HLSL3028B	199, 611	HLSLR2060	189	HLSLW486L	221, 525
HLSL2036SC	217	HLSL3028E	194	HLSLR2066	189	HLSLW486R	221, 525
HLSL2036TS	204	HLSL3028EBL	605	HLSLR2072	189	HLSLZ55C54	192, 249, 712
HLSL2060LDO	211, 521	HLSL3028EBR	605	HLSLR2436	189	HLSLZ55C60	84, 192, 249, 712
HLSL2060LDOF	213	HLSL3028F	199, 611	HLSLR2442	189	HLSLZ55C66	84, 192, 249, 712
HLSL2060LD2	211, 521	HLSL3028O	94, 193, 253, 604	HLSLR2448	189, 197, 600	HLSLZ55C72	84, 192, 249, 712
HLSL2060LD2F	213	HLSL3028S	199, 611	HLSLR2448J	191	HLSLZ55C78	84
HLSL2060LD4	211, 521	HLSL3028SL	94, 193, 254	HLSLR2454	189, 197, 600	HLSLZ55C84	84, 192, 249, 712
HLSL2060LD4F	213	HLSL3041O	94, 195, 253, 609	HLSLR2460	189, 197, 600	HLVPM1	110, 165, 227, 289, 325, 339
HLSL2060LL2	211, 521	HLSL3041S	196	HLSLR2460J	191	HLVPM2	110, 165, 289, 325
HLSL2060LL2F	214	HLSL3041SL	94, 195, 253, 609	HLSLR2466	189, 197, 600	HMAST	114, 166, 226, 293, 544, 616
HLSL2060LR2	211, 521	HLSL307O	94, 193, 212, 254	HLSLR2472	189, 197, 600	HMASTS	114, 166, 226, 293, 544, 616
HLSL2060LR2F	214	HLSL307SL	193	HLSLR2472J	191	HMBPOST	96
HLSL2060S4	211, 521	HLSL30OBC	200, 612	HLSLR2484	189	HMBPOST1	606
HLSL2060S4F	214	HLSL3414LM	88, 201	HLSLR3036	190	HMBTLEG24	96
HLSL2072LDO	211, 521	HLSL3428LM	88, 201	HLSLR3042	190	HMP120EL4828	500
HLSL2072LDOF	213	HLSL3614L	87, 201, 257, 603	HLSLR3048	190, 197, 600	HMP120EL6028	500
HLSL2072LD2	211, 521	HLSL3614MM	87, 202, 258, 603	HLSLR3048J	191	HMP120POST	500
HLSL2072LD2F	213	HLSL3635TS	204	HLSLR3054	190, 197, 600	HMP120TROUGH36	502
HLSL2072LD4	211, 521	HLSL36TW	207, 209	HLSLR3060	190, 197, 600	HMP120TROUGH42	502
HLSL2072LD4F	213	HLSL4014LM	88, 201	HLSLR3060J	191	HMP120TROUGH48	502
HLSL2072LL2	211, 521	HLSL4028LM	88, 201	HLSLR3066	190, 197, 600	HMP120UB236	501
HLSL2072LL2F	214	HLSL4214L	87, 201, 257, 603	HLSLR3072	190, 197, 600	HMP120UB242	501
HLSL2072LR2	211, 521	HLSL4214MM	87, 202, 258, 603	HLSLR3072J	191	HMP120UB248	501
HLSL2072LR2F	214	HLSL4235TS	204	HLSLR3084	190	HMP144	518
HLSL2072S4	211, 521	HLSL42TW	207, 209	HLSLR3660	190	HMP2460PK2	512
HLSL2072S4F	214	HLSL4814L	87, 201, 257, 603	HLSLR3666	190	HMP2460PK4	512
HLSL207O	193, 212	HLSL4814MM	87, 202, 258, 603	HLSLR3672	190	HMP2460PK6	512
HLSL207SL	193	HLSL4828O	94, 193, 253	HLSLSB	209	HMP2460PK8	512
HLSL22OSPL	208, 557	HLSL4831MB	225	HLSLSPBL	195	HMP2472PK2	512
HLSL2428B	199, 611	HLSL4835TS	204	HLSLSPBR	195	HMP2472PK4	512
HLSL2428E	194	HLSL48TW	207, 209	HLSLW045L	220, 524	HMP2472PK6	512
HLSL2428EBL	605	HLSL4AM2	194	HLSLW045LF	222	HMP2472PK8	512
HLSL2428EBR	605	HLSL50OS	209, 556	HLSLW045R	220, 524	HMP3060PK2	512
HLSL2428F	199, 611	HLSL5414L	87, 201, 257, 603	HLSLW045RF	222	HMP3060PK4	512
HLSL2428O	94, 193, 253, 604	HLSL5414MM	87, 202, 258, 603	HLSLW046L	220, 524	HMP3060PK6	512
HLSL2428S	199, 611	HLSL5435TS	204	HLSLW046R	220, 524	HMP3060PK8	512
HLSL2428SL	94, 193, 254	HLSL6014L	87, 201, 257, 603	HLSLW084L	222	HMP3072PK2	512
HLSL2430L	200, 612	HLSL6014MM	87, 202, 258, 603	HLSLW084LF	222	HMP3072PK4	512
HLSL2430MF	200, 612	HLSL6028O	94, 193, 253	HLSLW084R	222	HMP3072PK6	512
HLSL2436L2	217	HLSL6035TS	204	HLSLW084RF	222	HMP3072PK8	512
HLSL2436L4	217	HLSL60TW	207, 209	HLSLW085L	221, 525	HMPCF52413	509
HLSL2436SC	217	HLSL65OS	209, 556	HLSLW085LF	222	HMPCF52420	509
HLSL2441O	94, 195, 253, 609	HLSL6635TS	204	HLSLW085R	221, 525	HMPCF53013	509
HLSL2441S	196	HLSL66TW	207, 209	HLSLW085RF	222	HMPCF53020	509

CROSS REFERENCE INDEX

MODEL	PAGE	MODEL	PAGE	MODEL	PAGE	MODEL	PAGE
HMPCFS3613	509	HMPHA3060PK2	513	HMTLSCRN2054	597, 740	HNL231028PBBF	101
HMPCFS3620	509	HMPHA3060PK4	513	HMTLSCRN2060	597, 740	HNL231028PFF	101
HMPCFS4213	509	HMPHA3060PK6	513	HMTLSCRN2066	597, 740	HNL231041PBBFF	103
HMPCFS4220	509	HMPHA3060PK8	513	HMTLSCRN2524	740	HNL231628PBBF	101
HMPCFS4813	509	HMPHA3072PK2	513	HMTLSCRN2530	740	HNL231628PFF	101
HMPCFS4820	509	HMPHA3072PK4	513	HMTLSCRN2536	740	HNL231641PBBFF	103
HMPCFS6013	509	HMPHA3072PK6	513	HMTLSCRN2548	597, 740	HNL231641PSBBF	103
HMPCFS6020	509	HMPHA3072PK8	513	HMTLSCRN2554	597, 740	HNL231828PBBF	101
HMPDFS2413	508	HMPHABEORKIT	506	HMTLSCRN2560	597, 740	HNL231828PFF	101
HMPDFS2420	508	HMPHASLID20	506	HMTLSCRN2566	597, 740	HNL233028PBK	102
HMPDFS3013	508	HMPHASLID48	506	HN899900	421, 466	HNL233028PLF	101
HMPDFS3020	508	HMPHASLID60	506	HN899910	421, 466	HNL233028PSC	102
HMPDMS2413	508	HMPHASLID72	506	HNL11SUPP	93	HNL233028PSL	102
HMPDMS3013	508	HMPHATFWML	520, 576, 598	HNL122428BKE	102	HNL233628PBK	102
HMPEL2428	499	HMPHATROUGH20	506	HNL123028BKE	102	HNL233628PLF	101
HMPEL3028	499	HMPHATROUGH48	506	HNL123628BKE	102	HNL233628PSC	102
HMPEL4828	499	HMPHATROUGH60	506	HNL1530BK2	77	HNL233628PSL	102
HMPEL6028	499	HMPHATROUGH72	506	HNL1530BK3	77	HNL241850TLL	76
HMPFG2413	510	HMPHAWTWML	520, 576	HNL1530BK4	77	HNL241850TLR	76
HMPFG2420	510	HMPJUMP	518	HNL1530BK5	77	HNL241865SFL	73
HMPFG3013	510	HMPJUMP	518	HNL1530BK6	77	HNL241865SFLR	73
HMPFG3020	510	HMPJUMP	518	HNL1530FD	63	HNL241865SFX	73
HMPFG3613	510	HMPJUMP	518	HNL1530LD	62	HNL241865WLL	75
HMPFG3620	510	HMPJUMP	518	HNL1530LL	62	HNL241865WLR	75
HMPFG4213	510	HMPJUMP	518	HNL1536FD	63	HNL241879WLL	75
HMPFG4220	510	HMPJUMP	518	HNL1536LD	62	HNL241879WLR	75
HMPFG4813	510	HMPJUMP	518	HNL1536LL	62	HNL242465TLL	76
HMPFG4820	510	HMPJUMP	518	HNL1542FD	63	HNL242465TLR	76
HMPFG6013	510	HMPJUMP	518	HNL1542LD	62	HNL242479TLL	76
HMPFG6020	510	HMPJUMP	518	HNL1542LL	62	HNL242479TLR	76
HMPFG7213	510	HMPJUMP	518	HNL1548FD	63	HNL2424BK5CL	77
HMPFG7220	510	HMPJUMP	518	HNL1548LD	62	HNL2424BK5CR	77
HMPFGS3613	510	HMPJUMP	518	HNL1548LL	62	HNL243629SC	73
HMPFGS3620	510	HMPJUMP	518	HNL1548SD	63	HNL243665SC	73
HMPFGS4213	510	HMPJUMP	518	HNL1560FD	63	HNL243665SLL	74
HMPFGS4220	510	HMPJUMP	518	HNL1560LD	62	HNL243665WL	75
HMPFGS4813	510	HMPJUMP	518	HNL1560LL	62	HNL243665WLB	75
HMPFGS4820	510	HMPJUMP	518	HNL1560SD	63	HNL243665WRBL	75
HMPFGS5413	510	HMPJUMP	518	HNL1566FD	63	HNL243679SC	73
HMPFGS5420	510	HMPJUMP	518	HNL1566LD	62	HNL243679WL	75
HMPFGS6013	510	HMPJUMP	518	HNL1566LL	62	HNL243679WLB	75
HMPFGS6020	510	HMPJUMP	518	HNL1566SD	63	HNL243679WRBL	75
HMPFGS7213	510	HMPJUMP	518	HNL1572FD	63	HNL2436LD2	72
HMPFGS7220	510	HMPJUMP	518	HNL1572LD	62	HNL2436LD3	72
HMPFSS3613	509, 597	HMPJUMP	518	HNL1572LL	62	HNL2436LD4	72
HMPFSS3620	509, 597	HMPJUMP	518	HNL1572SD	63	HNL2442BF	52
HMPFSS4213	509, 597	HMPJUMP	518	HNL1578FD	63	HNL2442LP	51
HMPFSS4220	509, 597	HMPJUMP	518	HNL1578LD	62	HNL2442RP	51
HMPFSS4813	509, 597	HMPJUMP	518	HNL1578LL	62	HNL2448BF	52
HMPFSS4820	509, 597	HMPJUMP	518	HNL1578SD	63	HNL2448LP	51
HMPFSS5413	509, 597	HMPJUMP	518	HNL1772RT	69	HNL2448RP	51
HMPFSS5420	509, 597	HMPJUMP	518	HNL203021D2	50	HNL2460DPK	49
HMPFSS6013	509, 597	HMPJUMP	518	HNL2030MSFC	71	HNL2466DPK	49
HMPFSS6020	509, 597	HMPJUMP	518	HNL203621D2	50	HNL2472DPK	49
HMPHA2460PK2	513	HMPJUMP	518	HNL206021D4	50	HNL2472DPS	49
HMPHA2460PK4	513	HMPJUMP	518	HNL206021LD2	50	HNL2472LCC	49
HMPHA2460PK6	513	HMPJUMP	518	HNL206021RD2	50	HNL2472LP	49
HMPHA2460PK8	513	HMPJUMP	518	HNL207221D4	50	HNL2472RLC	49
HMPHA2472PK2	513	HMPJUMP	518	HNL207221LD2	50	HNL2472RP	49
HMPHA2472PK4	513	HMPJUMP	518	HNL207221RD2	50	HNL291028PBBF	101
HMPHA2472PK6	513	HMPJUMP	518	HNL2116MBBF	71	HNL291028PFF	101
HMPHA2472PK8	513	HMPJUMP	518	HNL2116MBF	71	HNL291041PBBFF	103
HMPHA254C	506	HMPJUMP	518	HNL2116MFF	71	HNL291628PBBF	101

CROSS REFERENCE INDEX

MODEL	PAGE	MODEL	PAGE	MODEL	PAGE	MODEL	PAGE
HNL291628PFF	101	HNL3660LL	55	HNL4966LL	57	HNLMP4228	86
HNL291641PBBFF	103	HNL3660SD	56	HNL4966SD	59	HNLMP4810	86
HNL291641PSBBF	103	HNL3666FD	55	HNL4972FD	58	HNLMP4828	86
HNL2930FD	64	HNL3666LD	55	HNL4972LD	57	HNLMP5410	86
HNL2930LD	64	HNL3666LL	55	HNL4972LL	57	HNLMP5428	86
HNL2930LL	64	HNL3666SD	56	HNL4972SD	59	HNLMP6010	86
HNL2936FD	64	HNL3672BUEP	46	HNL4978FD	58	HNLMP6028	86
HNL2936LD	64	HNL3672DPBB	43	HNL4978LD	57	HNLMP6610	86
HNL2936LL	64	HNL3672DPBBF	43	HNL4978LL	57	HNLMP6628	86
HNL2942FD	64	HNL3672DPBR	43	HNL4978SD	59	HNLMP7210	86
HNL2942LD	64	HNL3672DPRB	43	HNL7872RLT	70	HNLMP7228	86
HNL2942LL	64	HNL3672DPRBF	43	HNL7872RT	69	HNLMP7810	86
HNL2948FD	64	HNL3672DPRR	43	HNL8472RLT	70	HNLMP7828	86
HNL2948LD	64	HNL3672FD	55	HNL8472RT	69	HNLMP8410	86
HNL2948LL	64	HNL3672LD	55	HNLB3048	82	HNLMP8428	86
HNL2948SD	65	HNL3672LL	55	HNLB3060	82	HNLMP9010	86
HNL2960FD	64	HNL3672LPBB	44	HNLB3066	82	HNLMP9028	86
HNL2960LD	64	HNL3672LPBBF	44	HNLB3072	82	HNLMP9610	86
HNL2960LL	64	HNL3672LPBR	44	HNLB3078	82	HNLMP9628	86
HNL2960SD	65	HNL3672LPRB	45	HNLB3084	82	HNLPB1028	105
HNL2966FD	64	HNL3672LPRBF	45	HNLBW3672	82	HNLPB1041	105
HNL2966LD	64	HNL3672LPRR	45	HNLBW3684	82	HNLPB1628	105
HNL2966LL	64	HNL3672RPBB	44	HNLCDSHELF	106	HNLPB1641	105
HNL2966SD	65	HNL3672RPBBF	44	HNLEC367224L	83	HNLPB1828	105
HNL2972FD	64	HNL3672RPBR	44	HNLEC367224R	83	HNLPT2416	104
HNL2972LD	64	HNL3672RPRB	45	HNLEC487224L	83	HNLPT2418	104
HNL2972LL	64	HNL3672RPRBF	45	HNLEC487224R	83	HNLPT3016	104
HNL2972SD	65	HNL3672RPRR	45	HNLEP1128	91	HNLRC2042V	81
HNL2978FD	64	HNL3672SD	56	HNLEP1141	91	HNLRC2048V	81
HNL2978LD	64	HNL3678FD	55	HNLEP2428L	90	HNLRC2430	80
HNL2978LL	64	HNL3678LD	55	HNLEP2428R	90	HNLRC2430V	81
HNL2978SD	65	HNL3678LL	55	HNLEP2441L	90	HNLRC2436	80
HNL301850TLL	76	HNL3678SD	56	HNLEP2441R	90	HNLRC2436V	81
HNL301850TLR	76	HNL4272JLEP	46	HNLEP247L	92, 250	HNLRC2442	80
HNL3060DPRF	43	HNL4272JREP	46	HNLEP247R	92, 250	HNLRC2442V	81
HNL3066BUEP	46	HNL4872JLEP	46	HNLEP3028L	90	HNLRC2448	80, 602
HNL3066DPRF	43	HNL4872JREP	46	HNLEP3028R	90	HNLRC2448V	81
HNL3066LPRF	45	HNL4905SSEP	59	HNLEP3041L	90	HNLRC2454	80
HNL3066RPRF	45	HNL4930BHLD	66	HNLEP3041R	90	HNLRC2454V	81
HNL3072BUEP	46	HNL4930BHXD	66	HNLEP307L	92, 250	HNLRC2460	80, 602
HNL3605SSEP	56	HNL4930TB	106	HNLEP307R	92, 250	HNLRC2460V	81
HNL3630BHLD	66	HNL4930WB	106	HNLEP3628L	90	HNLRC2466	80, 602
HNL3630BHXD	66	HNL4936BHFD	67	HNLEP3628R	90	HNLRC2472	80, 602
HNL3630TB	106	HNL4936BHLD	66	HNLLB1013	105	HNLRC2478	80
HNL3630WB	106	HNL4936BHXD	66	HNLLB1018	105	HNLRC2484	80
HNL3636BHFD	67	HNL4936FD	58	HNLLB1613	105	HNLRC2490	80
HNL3636BHLD	66	HNL4936LD	57	HNLLB1618	105	HNLRC2496	80
HNL3636BHXD	66	HNL4936LL	57	HNLLB1818	105	HNLRC3048	80, 602
HNL3636CU	48	HNL4936TB	106	HNLLB3018	105	HNLRC3060	80, 602
HNL3636FD	55	HNL4936WB	106	HNLLB3618	105	HNLRC3066	80, 602
HNL3636LD	55	HNL4942FD	58	HNLLLEP2428L	92	HNLRC3072	80, 602
HNL3636LL	55	HNL4942LD	57	HNLLLEP2428R	92	HNLRC3078	80
HNL3636TB	106	HNL4942LL	57	HNLLLEP2441L	92	HNLRC3084	80
HNL3636WB	106	HNL4948FD	58	HNLLLEP2441R	92	HNLRC3672	80
HNL3642FD	55	HNL4948LD	57	HNLLLEP3028L	92	HNLRC3684	80
HNL3642LD	55	HNL4948LL	57	HNLLLEP3028R	92	HNLTEP2428	93
HNL3642LL	55	HNL4948SD	59	HNLLLEP3041L	92	HNLTEP3028	93
HNL3648FD	55	HNL4960FD	58	HNLLLEP3041R	92	HNLTEP3628	93
HNL3648LD	55	HNL4960LD	57	HNLMP3010	86	HNPMB5W24	436, 613
HNL3648LL	55	HNL4960LL	57	HNLMP3028	86	HNPMB5W30	436, 613
HNL3648SD	56	HNL4960SD	59	HNLMP3610	86	HNPMB5W36	436, 613
HNL3660FD	55	HNL4966FD	58	HNLMP3628	86	HNPMB5W42	436, 613
HNL3660LD	55	HNL4966LD	57	HNLMP4210	86	HNPMB5W48	436, 613

CROSS REFERENCE INDEX

MODEL	PAGE	MODEL	PAGE	MODEL	PAGE	MODEL	PAGE
HNPMB5W60	436, 613	HPWRMOD2WC	109, 169, 234, 347, 355, 362, 375, 520, 576, 615	HRVC22PL	423	HRVD9542P	421
HOLEG12	604			HRVC22PS	423	HRVEP1129L	390, 604
HOLEG24	604	HPWRMOD3UWM	109, 169, 234, 520, 576, 615	HRVC22PT	423	HRVEP1129R	390, 604
HOLEG30	604			HRVC22PX	423	HRVEP2429L	390, 604
HP3231	354	HPWRMOD3WC	109, 169, 234, 347, 355, 362, 375, 520, 576, 615	HRVC30PF	425	HRVEP2429R	390, 604
HP3235R	353			HRVC30PFT	425	HRVEP3029L	390, 604
HP3236L	353	HRABAB	440	HRVC30PFV	425	HRVEP3029R	390, 604
HP3251R	353	HREC2S2LCF	594	HRVC30PL	423	HRVF1524	419
HP3261	353	HREC2S2LTF	594	HRVC30PS	423	HRVF1530	419
HP3262	353	HREC3S2LCF	594	HRVC30PT	423	HRVF1536	419
HP3265R	353	HREC3S2LTF	594	HRVC30PX	423	HRVF1542	419
HP3266L	353	HREC3S3LCF	595	HRVC35GP	446	HRVF1548	419
HP3276	353	HREC3S3LTF	595	HRVC35PCE	425, 473, 608	HRVF1560	419
HPC180G	47, 154, 269, 316	HRFF3524P	418	HRVC35PCM	425, 473, 608	HRVF3024	419
HPC180W	47	HRFF3530P	418	HRVC35PF	425	HRVF3030	419
HPC190X	46, 95, 251	HRFF3536P	418	HRVC35PL	423	HRVF3036	419
HPC191X	46, 95, 251	HRFF3542P	418	HRVC35PS	423	HRVF3042	419
HPCWI	540, 674, 723	HRFF3548P	418	HRVC35PT	423	HRVF3048	419
HPD2PNBRK2L	607	HRFF3560P	418	HRVC35PX	423	HRVF3060	419
HPD2PNBRK2R	607	HRFF4224P	418	HRVC35PY2	424	HRVF3524P	417
HPMARKER1	747	HRFF4230P	418	HRVC35PY3	424	HRVF3530P	417
HPNLSTACK1524	744	HRFF4236P	418	HRVC42GP	446	HRVF3536P	417
HPNLSTACK1530	744	HRFF4242P	418	HRVC42PF	425	HRVF3542P	417
HPNLSTACK1536	744	HRFF4248P	418	HRVC42PL	423	HRVF3548P	417
HPNLSTACK1542	744	HRFF4260P	418	HRVC42PS	423	HRVF3560P	417
HPNLSTACK1548	744	HRFF5024P	418	HRVC42PT	423	HRVF4224P	417
HPNLSTACK1554	744	HRFF5030P	418	HRVC42PX	423	HRVF4230P	417
HPNLSTACK1560	744	HRFF5036P	418	HRVC42PY2	424	HRVF4236P	417
HPNLSTACK1566	744	HRFF5042P	418	HRVC42PY3	424	HRVF4242P	417
HPNLSTACK1572	744	HRFF5048P	418	HRVC50GP	446	HRVF4248P	417
HPNLSTACK1578	744	HRFF5060P	418	HRVC50PF	425	HRVF4260P	417
HPNLSTACK1584	744	HRFF6524P	418	HRVC50PL	423	HRVF5024P	417
HPNLSTACK1590	744	HRFF6530P	418	HRVC50PS	423	HRVF5030P	417
HPNLSTACK1596	744	HRFF6536P	418	HRVC50PT	423	HRVF5036P	417
HPNLSTACK2224	744	HRFF6542P	418	HRVC50PX	423	HRVF5042P	417
HPNLSTACK2230	744	HRFF6548P	418	HRVC50PY2	424	HRVF5048P	417
HPNLSTACK2236	744	HRFF6560P	418	HRVC50PY3	424	HRVF5060P	417
HPNLSTACK2242	744	HRFTAB	440	HRVC65GP	446	HRVF6524P	417
HPNLSTACK2248	744	HRVBPLATE336	420, 571	HRVC65PF	425	HRVF6530P	417
HPNLSTACK2254	744	HRVBPLATE342	420, 571	HRVC65PL	423	HRVF6536P	417
HPNLSTACK2260	744	HRVBPLATE348	420, 571	HRVC65PS	423	HRVF6542P	417
HPNLSTACK2266	744	HRVBPLATE360	420, 571	HRVC65PT	423	HRVF6548P	417
HPNLSTACK2272	744	HRVBR1524	592	HRVC65PW	425	HRVF6560P	417
HPNLSTACK2278	744	HRVBR1524P	592	HRVC65PX	423	HRVFFOOT	418
HPNLSTACK2284	744	HRVBR1530	592	HRVC65PY2	424	HRVFSB24	419
HPNLSTACK2290	744	HRVBR1530P	592	HRVC65PY3	424	HRVFSB30	419
HPNLSTACK2296	744	HRVBR1536	592	HRVC7FFV	425	HRVFSB36	419
HPNLSTACKBKT	744	HRVBR1536P	592	HRVC7PFT	425	HRVFSB42	419
HPPMAS	437, 613	HRVBR1542	592	HRVC7PFV	425	HRVFSB48	419
HPPMFB	437, 613	HRVBR1548	592	HRVC7PL	423	HRVFSB60	419
HPPMPB	437, 613	HRVBR1560	592	HRVC7PS	423	HRVFSBW24	426
HPPMPS	437, 613	HRVBR1566	592	HRVC7PT	423	HRVFSBW30	426
HPPMPT	437, 613	HRVBR1572	592	HRVC7PX	423	HRVFSBW36	426
HPPMST	437, 613	HRVC15FFV	425	HRVC80PF	425	HRVFSBW42	426
HPSEAT18ND	723	HRVC15PF	425	HRVC80PL	423	HRVFSBW48	426
HPSEAT24ND	540, 542, 543, 674, 677, 681, 697, 723	HRVC15PFT	425	HRVC80PS	423	HRVFSBW60	426
		HRVC15PFV	425	HRVC80PT	423	HRVG351824GGNS	451
HPULL2	648	HRVC15PL	423	HRVC80PX	423	HRVG351824GGNSG	451
HPULL3	648	HRVC15PS	423	HRVCE	446	HRVG351830GGNS	451
HPWRMOD2	109, 169, 234, 256, 520, 598, 615	HRVC15PT	423	HRVCLG24	390, 604	HRVG351830GGNSG	451
		HRVC15PX	423	HRVCLG30	390, 604	HRVG3518GGL	449
HPWRMOD2UWM	109, 169, 234, 520, 576, 615	HRVC22PFT	425	HRVCM	446	HRVG3518GGLG	449
		HRVC22PFV	425	HRVD0742T	421	HRVG3518GGR	448

CROSS REFERENCE INDEX

MODEL	PAGE	MODEL	PAGE	MODEL	PAGE	MODEL	PAGE
HRVG3518GGRG	448	HRVG3560L	441	HRVG4248GGLG	449	HRVG5036L	441
HRVG3518GGT	450	HRVG3560LG	443	HRVG4248GGR	448	HRVG5036LG	443
HRVG3518GGTG	450	HRVG3563L	441, 442	HRVG4248GGRG	448	HRVG5039L	441
HRVG352418GGNS	451	HRVG3563LG	443, 444	HRVG4248GGT	450	HRVG5039LG	443
HRVG352418GGNSG	451	HRVG3572GGT	450	HRVG4248GGTG	450	HRVG5042GGL	449
HRVG352430GGNSG	451	HRVG3572GGTG	450	HRVG4248L	441	HRVG5042GGLG	449
HRVG3524GGL	449	HRVG3575L	441, 442	HRVG4248LG	443	HRVG5042GGR	448
HRVG3524GGLG	449	HRVG3575LG	443, 444	HRVG4251L	441, 442	HRVG5042GGRG	448
HRVG3524GGR	448	HRVG421824GGNS	451	HRVG4251LG	443, 444	HRVG5042GGT	450
HRVG3524GGRG	448	HRVG421824GGNSG	451	HRVG4260GGL	449	HRVG5042GGTG	450
HRVG3524L	441	HRVG421830GGNS	451	HRVG4260GGLG	449	HRVG5042L	441
HRVG3524LG	443	HRVG421830GGNSG	451	HRVG4260GGR	448	HRVG5042LG	443
HRVG3527L	441	HRVG4218GGL	449	HRVG4260GGRG	448	HRVG5045L	441
HRVG3527LG	443	HRVG4218GGLG	449	HRVG4260GGT	450	HRVG5045LG	443
HRVG353018GGNS	451	HRVG4218GGR	448	HRVG4260GGTG	450	HRVG5048GGL	449
HRVG353018GGNSG	451	HRVG4218GGRG	448	HRVG4260L	441	HRVG5048GGLG	449
HRVG353024GGNS	451	HRVG4218GGT	450	HRVG4260LG	443	HRVG5048GGR	448
HRVG353024GGNSG	451	HRVG4218GGTG	450	HRVG4263L	441, 442	HRVG5048GGRG	448
HRVG3530GGL	449	HRVG422418GGNS	451	HRVG4263LG	443, 444	HRVG5048GGT	450
HRVG3530GGLG	449	HRVG422418GGNSG	451	HRVG4272GGT	450	HRVG5048GGTG	450
HRVG3530GGR	448	HRVG422430GGNS	451	HRVG4272GGTG	450	HRVG5048L	441
HRVG3530GGRG	448	HRVG422430GGNSG	451	HRVG4275L	441, 442	HRVG5048LG	443
HRVG3530GGRG	448	HRVG4224GGL	449	HRVG4275LG	443, 444	HRVG5051L	441, 442
HRVG3530L	441	HRVG4224GGLG	449	HRVG501824GGNS	451	HRVG5051LG	443, 444
HRVG3530LG	443	HRVG4224GGR	448	HRVG501824GGNSG	451	HRVG5060GGL	449
HRVG3533L	441	HRVG4224GGRG	448	HRVG501830GGNS	451	HRVG5060GGLG	449
HRVG3533LG	443	HRVG4224L	441	HRVG501830GGNSG	451	HRVG5060GGR	448
HRVG3536GGL	449	HRVG4224LG	443	HRVG5018GGL	449	HRVG5060GGRG	448
HRVG3536GGLG	449	HRVG4227L	441	HRVG5018GGLG	449	HRVG5060GGT	450
HRVG3536GGR	448	HRVG4227LG	443	HRVG5018GGR	448	HRVG5060GGTG	450
HRVG3536GGRG	448	HRVG423018GGNS	451	HRVG5018GGRG	448	HRVG5060L	441
HRVG3536GGT	450	HRVG423018GGNSG	451	HRVG5018GGT	450	HRVG5060LG	443
HRVG3536GGTG	450	HRVG423024GGNS	451	HRVG5018GGTG	450	HRVG5063L	441, 442
HRVG3536L	441	HRVG423024GGNSG	451	HRVG502418GGNS	451	HRVG5063LG	443, 444
HRVG3536LG	443	HRVG4230GGL	449	HRVG502418GGNSG	451	HRVG5072GGT	450
HRVG3539L	441	HRVG4230GGLG	449	HRVG502430GGNS	451	HRVG5072GGTG	450
HRVG3539LG	443	HRVG4230GGR	448	HRVG502430GGNSG	451	HRVG5075L	441, 442
HRVG3542GGL	449	HRVG4230GGRG	448	HRVG5024GGL	449	HRVG5075LG	443, 444
HRVG3542GGLG	449	HRVG4230L	441	HRVG5024GGLG	449	HRVGLSK	446
HRVG3542GGR	448	HRVG4230LG	443	HRVG5024GGR	448	HRVGMSK	446
HRVG3542GGRG	448	HRVG4233L	441	HRVG5024GGRG	448	HRVGTGG	452
HRVG3542GGT	450	HRVG4233LG	443	HRVG5024L	441	HRVOH1530RM	550
HRVG3542GGTG	450	HRVG4236GGL	449	HRVG5024LG	443	HRVOH1536RM	550
HRVG3542L	441	HRVG4236GGLG	449	HRVG5027L	441	HRVOH1542RM	550
HRVG3542LG	443	HRVG4236GGR	448	HRVG5027LG	443	HRVOH1548RM	550
HRVG3545L	441	HRVG4236GGRG	448	HRVG503018GGNS	451	HRVOH1560RM	550
HRVG3545LG	443	HRVG4236GGT	450	HRVG503018GGNSG	451	HRVOH24FM	550
HRVG3548GGL	449	HRVG4236GGTG	450	HRVG503024GGNS	451	HRVOH30FM	550
HRVG3548GGLG	449	HRVG4236L	441	HRVG503024GGNSG	451	HRVOH36FM	550
HRVG3548GGR	448	HRVG4236LG	443	HRVG5030GGL	449	HRVOH42FM	550
HRVG3548GGRG	448	HRVG4239L	441	HRVG5030GGLG	449	HRVOH48FM	550
HRVG3548GGT	450	HRVG4239LG	443	HRVG5030GGR	448	HRVOH60FM	550
HRVG3548GGTG	450	HRVG4242GGL	449	HRVG5030GGRG	448	HRVOH72FM	550
HRVG3548L	441	HRVG4242GGLG	449	HRVG5030L	441	HRVOHV24HLA	553
HRVG3548LG	443	HRVG4242GGR	448	HRVG5030LG	443	HRVOHV24HMA	552
HRVG3551L	441, 442	HRVG4242GGRG	448	HRVG5033L	441	HRVOHV30HLA	553
HRVG3551LG	443, 444	HRVG4242GGT	450	HRVG5033LG	443	HRVOHV30HMA	552
HRVG3560GGL	449	HRVG4242GGTG	450	HRVG5036GGL	449	HRVOHV36HLA	553
HRVG3560GGLG	449	HRVG4242L	441	HRVG5036GGLG	449	HRVOHV36HMA	552
HRVG3560GGR	448	HRVG4242LG	443	HRVG5036GGR	448	HRVOHV42HLA	553
HRVG3560GGRG	448	HRVG4245L	441	HRVG5036GGRG	448	HRVOHV42HMA	552
HRVG3560GGT	450	HRVG4245LG	443	HRVG5036GGT	450	HRVOHV48HLA	553
HRVG3560GGTG	450	HRVG4248GGL	449	HRVG5036GGTG	450	HRVOHV48HMA	552

CROSS REFERENCE INDEX

MODEL	PAGE	MODEL	PAGE	MODEL	PAGE	MODEL	PAGE
HRVOMOD	426	HRVT1530W	436	HRVT3030CK	440	HRVT4524E	430
HRVP24P	574	HRVT1536CK	440	HRVT3030E	429	HRVT4524T	428
HRVP30P	574	HRVT1536E	429	HRVT3030G	432	HRVT4530E	430
HRVP36P	574	HRVT1536F	434	HRVT3030HS2	431	HRVT4530T	428
HRVP42P	574	HRVT1536G	432	HRVT3030M	438	HRVT4536E	430
HRVP48P	574	HRVT1536HS2	431	HRVT3030P	435	HRVT4536T	428
HRVP60P	574	HRVT1536M	438	HRVT3030PM	439	HRVT4542E	430
HRVSH24	550	HRVT1536PM	439	HRVT3030R	433	HRVT4542T	428
HRVSH30	550	HRVT1536R	433	HRVT3030T	427	HRVT4548E	430
HRVSH36	550	HRVT1536T	427	HRVT3036CK	440	HRVT4548T	428
HRVSH42	550	HRVT1536W	436	HRVT3036E	429	HRVT4560E	430
HRVSH48	550	HRVT1542CK	440	HRVT3036G	432	HRVT4560T	428
HRVSH60	550	HRVT1542E	429	HRVT3036HS2	431	HRVT6024E	430
HRVSH72	550	HRVT1542F	434	HRVT3036M	438	HRVT6024T	428
HRVSHV24	552	HRVT1542G	432	HRVT3036P	435	HRVT6030E	430
HRVSHV30	552	HRVT1542HS2	431	HRVT3036PM	439	HRVT6030T	428
HRVSHV36	552	HRVT1542M	438	HRVT3036R	433	HRVT6036E	430
HRVSHV42	552	HRVT1542PM	439	HRVT3036T	427	HRVT6036T	428
HRVSHV48	552	HRVT1542R	433	HRVT3042CK	440	HRVT6042E	430
HRVSS24	420	HRVT1542T	427	HRVT3042E	429	HRVT6042T	428
HRVSS30	420	HRVT1542W	436	HRVT3042G	432	HRVT6048E	430
HRVSS36	420	HRVT1548CK	440	HRVT3042HS2	431	HRVT6048T	428
HRVSS42	420	HRVT1548E	429	HRVT3042M	438	HRVT6060E	430
HRVSS48	420	HRVT1548F	434	HRVT3042P	435	HRVT6060T	428
HRVSS60	420	HRVT1548G	432	HRVT3042PM	439	HRVTB11	447
HRVTO724F	434	HRVT1548HS2	431	HRVT3042R	433	HRVTB18	447
HRVTO724T	427, 435	HRVT1548M	438	HRVT3042T	427	HRVTC24	417
HRVTO730F	434	HRVT1548PM	439	HRVT3048CK	440	HRVTC30	417
HRVTO730T	427, 435	HRVT1548R	433	HRVT3048E	429	HRVTC36	417
HRVTO736F	434	HRVT1548T	427	HRVT3048G	432	HRVTC42	417
HRVTO736T	427, 435	HRVT1548W	436	HRVT3048HS2	431	HRVTC48	417
HRVTO742F	434	HRVT1554F	434	HRVT3048M	438	HRVTC54	417
HRVTO742T	427, 435	HRVT1560CK	440	HRVT3048P	435	HRVTC60	417
HRVTO748F	434	HRVT1560E	429	HRVT3048PM	439	HRVTC66	417
HRVTO748T	427, 435	HRVT1560F	434	HRVT3048R	433	HRVTC72	417
HRVTO754F	434	HRVT1560G	432	HRVT3048T	427	HRVTC78	417
HRVTO760F	434	HRVT1560HS2	431	HRVT3060CK	440	HRVTC84	417
HRVTO760T	427, 435	HRVT1560M	438	HRVT3060E	429	HRVTC90	417
HRVTO766F	434	HRVT1560PM	439	HRVT3060G	432	HRVTC96	417
HRVTO772F	434	HRVT1560R	433	HRVT3060HS2	431	HRVTRAYM	438
HRVTO778F	434	HRVT1560T	427	HRVT3060M	438	HRVUP24	560
HRVTO784F	434	HRVT1560W	436	HRVT3060P	435	HRVUP30	560
HRVTO790F	434	HRVT1566F	434	HRVT3060PM	439	HRVUP36	560
HRVTO796F	434	HRVT1572F	434	HRVT3060R	433	HRVUP42	560
HRVT1524CK	440	HRVT1578F	434	HRVT3060T	427	HRVUP48	560
HRVT1524E	429	HRVT1584F	434	HRVT3724E	429	HRVUP60	560
HRVT1524F	434	HRVT1590F	434	HRVT3724HS2	431	HS1100	115, 170, 230, 296, 329, 341, 348, 356, 363, 376, 617
HRVT1524G	432	HRVT1596F	434	HRVT3724T	427	HS1101	115, 170, 230, 296, 329, 341, 348, 356, 363, 376, 617
HRVT1524HS2	431	HRVT2224T	427	HRVT3730E	429	HS1102	115, 170, 230, 296, 329, 341, 348, 356, 363, 376, 617
HRVT1524M	438	HRVT2230T	427	HRVT3730HS2	431	HS30ABC	637
HRVT1524PM	439	HRVT2236T	427	HRVT3730T	427	HS42ABC	637
HRVT1524R	433	HRVT2242T	427	HRVT3736E	429	HS60ABC	637
HRVT1524T	427	HRVT2248T	427	HRVT3736HS2	431	HS72ABC	637
HRVT1524W	436	HRVT2260T	427	HRVT3736T	427	HS82ABC	637
HRVT1530CK	440	HRVT3024CK	440	HRVT3742E	429	HSC1842	638
HRVT1530E	429	HRVT3024E	429	HRVT3742HS2	431	HSC1872	638
HRVT1530F	434	HRVT3024G	432	HRVT3742T	427	HSC2472	638
HRVT1530G	432	HRVT3024HS2	431	HRVT3748E	429	HSCABD02	530, 636, 650
HRVT1530HS2	431	HRVT3024M	438	HRVT3748HS2	431	HSCABD10	530, 636, 650
HRVT1530M	438	HRVT3024P	435	HRVT3748T	427	HSCACW25	649
HRVT1530PM	439	HRVT3024PM	439	HRVT3760E	429		
HRVT1530R	433	HRVT3024R	433	HRVT3760HS2	431		
HRVT1530T	427	HRVT3024T	427	HRVT3760T	427		

CROSS REFERENCE INDEX

MODEL	PAGE	MODEL	PAGE	MODEL	PAGE	MODEL	PAGE
HSISLAUT2PYB7236S2	709	HSPFSF221518BFL(?)	540, 673	HSQLF652418RLE	671	HSTP422424LBBFM	531, 654
HSISLAUT2PYB7236S3	709	HSPFSF221524BFL(?)	542, 676	HSQLF652418RM	668	HSTP422424LFFL	533, 656
HSISLAUT2PYB7236S6	709	HSPFSF221524BFL(?)	540, 673	HSQLF652418RME	670	HSTP422424LFFM	531, 654
HSISLAUT2PYB8418S2	709	HSPH181518BFL(?)	675	HSQLP422418LL	669	HSTP422424RBBFL	533, 656
HSISLAUT2PYB8418S7	709	HSPH181518BFL(?)	672A	HSQLP422418LLE	671	HSTP422424RBBFM	531, 654
HSISLAUT2PYB8436S2	709	HSPH181524BFL(?)	675	HSQLP422418LM	668	HSTP422424RFFL	533, 656
HSISLAUT2PYB8436S7	709	HSPH181524BFL(?)	672A	HSQLP422418LME	670	HSTP502424LBBFM	531, 654
HSISLAUTNPNB2418S1	707	HSPH181530BFL(?)	675	HSQLP422418RL	669	HSTP501824LFFL	664
HSISLAUTNPNB2436S1	707	HSPH181530BFL(?)	672A	HSQLP422418RLE	671	HSTP501824LFFM	662
HSISLAUTNPNB3018S1	707	HSPM211518BFL(?)	541, 675	HSQLP422418RM	668	HSTP501824RFFL	664
HSISLAUTNPNB3036S1	707	HSPM211518BFL(?)	539, 672A	HSQLP422418RME	670	HSTP501824RFFM	662
HSISLAUTNPNB3618S1	707	HSPM211524BFL(?)	541, 675	HSQLP652418LL	669	HSTP502424LBBFL	533, 656
HSISLAUTNPNB3618S3	707	HSPM211524BFL(?)	539, 672A	HSQLP652418LLE	671	HSTP502424LBBFM	531, 654
HSISLAUTNPNB3636S1	707	HSPM271518BBFL(?)	675	HSQLP652418LM	668	HSTP502424LFFL	533, 656
HSISLAUTNPNB3636S3	707	HSPM271518BBFL(?)	672A	HSQLP652418LME	670	HSTP502424LFFM	531, 654
HSISLAUTNPNB4218S1	707	HSPM271518FFL(?)	675	HSQLP652418RL	669	HSTP502424RBBFL	533, 656
HSISLAUTNPNB4236S1	707	HSPM271518FFL(?)	672A	HSQLP652418RLE	671	HSTP502424RBBFM	531, 654
HSISLAUTNPNB4818S1	707	HSPM271524BBFL(?)	675	HSQLP652418RM	668	HSTP502424RFFL	533, 656
HSISLAUTNPNB4818S2	707	HSPM271524BBFL(?)	672A	HSQLP652418RME	670	HSTP502424RFFM	531, 654
HSISLAUTNPNB4818S4	707	HSPM271524FFL(?)	675	HSTAKL	538, 661	HSTP651824LFFL	664
HSISLAUTNPNB4836S1	707	HSPM271524FFL(?)	672A	HSTAKR	538, 661	HSTP651824LFFM	662
HSISLAUTNPNB4836S2	707	HSPM271530BBFL(?)	675	HSTB2W1	84, 220, 254, 607	HSTP651824RFFL	664
HSISLAUTNPNB4836S4	707	HSPM271530BBFL(?)	672A	HSTF421824LFFL	665	HSTP651824RFFM	662
HSISLAUTNPNB6018S1	707	HSPM271530FFL(?)	675	HSTF421824LFFM	663	HSTP652424LBBFL	533, 656
HSISLAUTNPNB6018S2	707	HSPM271530FFL(?)	672A	HSTF421824RFFL	665	HSTP652424LBBFM	531, 654
HSISLAUTNPNB6018S5	707	HSPRAY	747	HSTF421824RFFM	663	HSTP652424LFFL	533, 656
HSISLAUTNPNB6036S1	707	HSPSBX281518BBFL(?)	675	HSTF422424LBBFL	537, 660	HSTP652424LFFM	531, 654
HSISLAUTNPNB6036S2	707	HSPSBX281518BBFL(?)	672A	HSTF422424LBBFM	535, 658	HSTP652424RBBFL	533, 656
HSISLAUTNPNB6036S5	707	HSPSBX281518FFL(?)	675	HSTF422424LFFL	537, 660	HSTP652424RBBFM	531, 654
HSISLAUTNPNB7218S1	707	HSPSBX281518FFL(?)	672A	HSTF422424LFFM	535, 658	HSTP652424RFFL	533, 656
HSISLAUTNPNB7218S2	707	HSPSBX281524BBFL(?)	675	HSTF422424RBBFL	537, 660	HSTP652424RFFM	531, 654
HSISLAUTNPNB7218S3	707	HSPSBX281524BBFL(?)	672A	HSTF422424RBBFM	535, 658	HSTSF421824LFFL	665
HSISLAUTNPNB7218S6	707	HSPSBX281524FFL(?)	675	HSTF422424RFFL	537, 660	HSTSF421824LFFM	663
HSISLAUTNPNB7236S1	707	HSPSBX281524FFL(?)	672A	HSTF422424RFFM	535, 658	HSTSF421824RFFL	665
HSISLAUTNPNB7236S2	707	HSPSBX281530BBFL(?)	675	HSTF501824LFFL	665	HSTSF421824RFFM	663
HSISLAUTNPNB7236S3	707	HSPSBX281530BBFL(?)	672A	HSTF501824LFFM	663	HSTSF422424LBBFL	538, 661
HSISLAUTNPNB7236S6	707	HSPSBX281530FFL(?)	675	HSTF501824RFFL	665	HSTSF422424LBBFM	536, 659
HSISLAUTNPNB8418S1	707	HSPSBX281530FFL(?)	672A	HSTF501824RFFM	663	HSTSF422424LFFL	538, 661
HSISLAUTNPNB8418S2	707	HSPSSF281518BBFL(?)	676	HSTF502424LBBFL	537, 660	HSTSF422424LFFM	536, 659
HSISLAUTNPNB8418S7	707	HSPSSF281518BBFM(?)	673	HSTF502424LBBFM	535, 658	HSTSF422424RBBFL	538, 661
HSISLAUTNPNB8436S1	707	HSPSSF281518FFL(?)	676	HSTF502424LFFL	537, 660	HSTSF422424RBBFM	536, 659
HSISLAUTNPNB8436S2	707	HSPSSF281518FFM(?)	673	HSTF502424LFFM	535, 658	HSTSF422424RFFL	538, 661
HSISLAUTNPNB8436S7	707	HSPSSF281524BBFL(?)	676	HSTF502424RBBFL	537, 660	HSTSF422424RFFM	536, 659
HSLACW50	648	HSPSSF281524BBFM(?)	673	HSTF502424RBBFM	535, 658	HSTSF501824LFFL	665
HSLACW57	648	HSPSSF281524FFL(?)	676	HSTF502424RFFL	537, 660	HSTSF501824LFFM	663
HSLDIGMGR	672, 699	HSPSSF281524FFM(?)	673	HSTF502424RFFM	535, 658	HSTSF501824RFFL	665
HSLDIGPRG	672, 699	HSPSSF281530BBFL(?)	676	HSTF651824LFFL	665	HSTSF501824RFFM	663
HSLF283018FFL	647	HSPSSF281530BBFM(?)	673	HSTF651824LFFM	663	HSTSF502424LBBFL	538, 661
HSLF283018FFM	647	HSPSSF281530FFL(?)	676	HSTF651824RFFL	665	HSTSF502424LBBFM	536, 659
HSLF283618FFL	647	HSPSSF281530FFM(?)	673	HSTF651824RFFM	663	HSTSF502424LFFL	538, 661
HSLF283618FFM	647	HSQLF422418LL	669	HSTF652424LBBFL	537, 660	HSTSF502424LFFM	536, 659
HSLP283018FFL	647	HSQLF422418LLE	671	HSTF652424LBBFM	535, 658	HSTSF502424RBBFL	538, 661
HSLP283018FFM	647	HSQLF422418LM	668	HSTF652424LFFL	537, 660	HSTSF502424RBBFM	536, 659
HSLP283618FFL	647	HSQLF422418LME	670	HSTF652424LFFM	535, 658	HSTSF502424RFFL	538, 661
HSLP283618FFM	647	HSQLF422418RL	669	HSTF652424RBBFL	537, 660	HSTSF502424RFFM	536, 659
HSLRFID100C	672	HSQLF422418RLE	671	HSTF652424RBBFM	535, 658	HSTSF651824LFFL	665
HSLRFID100S	672	HSQLF422418RM	668	HSTF652424RFFL	537, 660	HSTSF651824LFFM	663
HSLRFID25C	672	HSQLF422418RME	670	HSTF652424RFFM	535, 658	HSTSF651824RFFL	665
HSLRFID25S	672	HSQLF652418LL	669	HSTP421824LFFL	664	HSTSF651824RFFM	663
HSLRFID5C	672	HSQLF652418LLE	671	HSTP421824LFFM	662	HSTSF652424LBBFL	538, 661
HSLRFID5S	672	HSQLF652418LM	668	HSTP421824RFFL	664	HSTSF652424LBBFM	536, 659
HSPAK15	673	HSQLF652418LME	670	HSTP421824RFFM	662	HSTSF652424LFFL	538, 661
HSPFSF221518BFL(?)	542, 676	HSQLF652418RL	669	HSTP422424LBBFL	533, 656	HSTSF652424LFFM	536, 659

CROSS REFERENCE INDEX

MODEL	PAGE	MODEL	PAGE	MODEL	PAGE	MODEL	PAGE
HSTSF652424RBBFL	538, 661	HSWF651218RM	666	HUVDPSI330	737	HUVSSWT	732
HSTSF652424RBBFM	536, 659	HSWF651224LL	667	HUVDPS2024	737	HUVSTAHS	733
HSTSF652424RFFL	538, 661	HSWF651224LM	666	HUVDPS2030	737	HUVSTAHS	733
HSTSF652424RFFM	536, 659	HSWF651224RL	667	HUVDRWT	732	HUVSTAHS	733
HSTSP421824LFFL	664	HSWF651224RM	666	HUVDSAOEM1348	737	HUVSTBHSD	733
HSTSP421824LFFM	662	HSWP421218LL	667	HUVDSAOEM1360	737	HUVSTBHSP	733
HSTSP421824RFFL	664	HSWP421218LM	666	HUVDSAOEM1372	737	HUVSTBHST	733
HSTSP421824RFFM	662	HSWP421218RL	667	HUVDSAOEM2048	737	HUVTOWT	732
HSTSP422424LBBFL	534, 657	HSWP421218RM	666	HUVDSAOEM2060	737	HUVTOWT24	733
HSTSP422424LBBFM	532, 655	HSWP421224LL	667	HUVDSAOEM2072	737	HUVTOWT48	733
HSTSP422424LFFL	534, 657	HSWP421224LM	666	HUVDSAOI348	737	HUVTRWT	732
HSTSP422424LFFM	532, 655	HSWP421224RL	667	HUVDSAOI360	737	HUVVWWT	732
HSTSP422424RBBFL	534, 657	HSWP421224RM	666	HUVDSAOI372	737	HUVSTBHST	540, 610, 724
HSTSP422424RBBFM	532, 655	HSWP501218LL	667	HUVDSAO2048	737	HVFB20R	610
HSTSP422424RFFL	534, 657	HSWP501218LM	666	HUVDSAO2060	737	HVFB23R	610
HSTSP422424RFFM	532, 655	HSWP501218RL	667	HUVDSAO2072	737	HVFF20R	610
HSTSP501824LFFL	664	HSWP501218RM	666	HUVDSBS2048	738	HVFF23R	610
HSTSP501824LFFM	662	HSWP501224LL	667	HUVDSBS2060	738	HVL981	116, 171, 231, 297, 330, 342,
HSTSP501824RFFL	664	HSWP501224LM	666	HUVDSBS2072	738		349, 357, 364, 377, 545, 618
HSTSP501824RFFM	662	HSWP501224RL	667	HUVDSHAB4813	738	HVL982	116, 171, 231, 297, 330, 342,
HSTSP502424LBBFL	534, 657	HSWP501224RM	666	HUVDSHAB4820	738		349, 357, 364, 377, 545, 618
HSTSP502424LBBFM	532, 655	HSWP651218LL	667	HUVDSHAB6013	738	HVL991	116, 171, 231, 297, 330, 342,
HSTSP502424LFFL	534, 657	HSWP651218LM	666	HUVDSHAB6020	738		349, 357, 364, 377, 545, 618
HSTSP502424LFFM	532, 655	HSWP651218RL	667	HUVDSHAB7213	738	HVPWLBK24	84, 254
HSTSP502424RBBFL	534, 657	HSWP651218RM	666	HUVDSHAB7220	738	HVPWLBK30	84, 254
HSTSP502424RBBFM	532, 655	HSWP651224LL	667	HUVDSSE1324	737	HWC3624P	584
HSTSP502424RFFL	534, 657	HSWP651224LM	666	HUVDSSE1330	737	HWC4224P	584
HSTSP502424RFFM	532, 655	HSWP651224RL	667	HUVDSSE2024	737	HWC4230P	584
HSTSP651824LFFL	664	HSWP651224RM	666	HUVDSSE2030	737	HWC4824P	584
HSTSP651824LFFM	662	HT48ND	380	HUVDSSE2048	738	HWC4830P	584
HSTSP651824RFFL	664	HT60ND	380	HUVDSSE2072	738	HWC72	638
HSTSP651824RFFM	662	HT66ND	380	HUVDSSE2096	738	HWC3624P	585
HSTSP652424LBBFL	534, 657	HT72ND	380	HUVDSSE2136	738	HWCS4224P	585
HSTSP652424LBBFM	532, 655	HTCOL52	70, 163, 287, 323, 339	HUVDSSE2160	738	HWCS4230P	585
HSTSP652424LFFL	534, 657	HTWTH	552	HUVDSSE2184	738	HWCS4824P	585
HSTSP652424LFFM	532, 655	HUVAAS	733	HUVDSSE2208	738	HWCS4830P	585
HSTSP652424RBBFL	534, 657	HUVABLS2424L	738	HUVDSSE2232	738	HWD244830P	583
HSTSP652424RBBFM	532, 655	HUVABLS2424R	738	HUVDSSE2256	738	HWD245430P	583
HSTSP652424RFFL	534, 657	HUVABLS2430L	738	HUVDSSE2280	738	HWD246030P	583
HSTSP652424RFFM	532, 655	HUVABLS2430R	738	HUVDSSE2304	738	HWD246630P	583
HSWEPA2	292, 324	HUVABLS3024L	738	HUVDSSE2328	738	HWD247230P	583
HSWEPA3	292, 324	HUVABLS3024R	738	HUVDSSE2352	738	HWD304824P	583
HSWEPC2	292, 324	HUVABLS3030L	738	HUVDSSE2376	738	HWD305424P	583
HSWEPC3	292, 324	HUVABLS3030R	738	HUVDSSE2400	738	HWD306024P	583
HSWF421218LL	667	HUVABLS3624L	738	HUVDSSE2424	738	HWD306624P	583
HSWF421218LM	666	HUVABLS3624R	738	HUVDSSE2448	738	HWD307224P	583
HSWF421218RL	667	HUVABLS3630L	738	HUVDSSE2472	738	HWJ58ABLP	589
HSWF421218RM	666	HUVABLS3630R	738	HUVDSSE2496	738	HWJ58ABRP	589
HSWF421224LL	667	HUVAUS482413	738	HUVDSSE2520	738	HWJ58BBLP	589
HSWF421224LM	666	HUVAUS482420	738	HUVDSSE2544	738	HWJ58BBRP	589
HSWF421224RL	667	HUVAUS483013	738	HUVDSSE2568	738	HWJ59ABLP	589
HSWF421224RM	666	HUVAUS483020	738	HUVDSSE2592	738	HWJ59ABRP	589
HSWF501218LL	667	HUVAUS602413	738	HUVDSSE2616	738	HWJ59BBLP	589
HSWF501218LM	666	HUVAUS602420	738	HUVDSSE2640	738	HWJ59BBRP	589
HSWF501218RL	667	HUVAUS603013	738	HUVDSSE2664	738	HWMCLIPLG	109, 233, 253
HSWF501218RM	666	HUVAUS603020	738	HUVDSSE2688	738	HWMCLIPSM	109, 233
HSWF501224LL	667	HUVAUS722413	738	HUVDSSE2712	738	HWP2460P	589
HSWF501224LM	666	HUVAUS722420	738	HUVDSSE2736	738	HWP2466P	589
HSWF501224RL	667	HUVAUS723013	738	HUVDSSE2760	738	HWP2472P	589
HSWF501224RM	666	HUVAUS723020	738	HUVDSSE2784	738	HWP3060P	589
HSWF651218LL	667	HUVCFCT24	733	HUVDSSE2808	738	HWP3066P	589
HSWF651218LM	666	HUVCFCT48	733	HUVDSSE2832	738	HWP3072P	589
HSWF651218RL	667	HUVDPIS324	737	HUVDSSE2856	738	HWR1824P	581

CROSS REFERENCE INDEX

MODEL	PAGE	MODEL	PAGE	MODEL	PAGE	MODEL	PAGE
HWR1830P	581	HWR2472PN	504	HWSR42	607	HWV95ABLP	587
HWR1836P	581	HWR2484P	581	HWSR48	607	HWV95ABRP	588
HWR1842P	581	HWR3024P	582	HWV73AALP	587	HWV95BALP	587
HWR1848P	581	HWR3030P	582	HWV73AARP	588	HWV95BARP	588
HWR1854P	581	HWR3036P	582	HWV73BALP	587	HWV95BBLP	587
HWR1860P	581	HWR3042P	582	HWV73BARP	588	HWV95BBRP	588
HWR1866P	581	HWR3048P	582	HWV75AALP	587	SPLH-ABND-GALGLSS.M482171	445
HWR1872P	581	HWR3048PN	504	HWV75AARP	588	SPLH-ABND-GALGLSS.M482172	445
HWR2424P	581	HWR3054P	582	HWV75ABLP	587	SPLH-ABND-GALGLSS.M482173	445
HWR2430P	581	HWR3060P	582	HWV75ABRP	588	SPLH-ABND-GALGLSS.M482174	445
HWR2436P	581	HWR3060PN	504	HWV75BALP	587	SPLH-ABND-GALGLSS.M482175	445
HWR2436PN	503, 504	HWR3066P	582	HWV75BARP	588	SPLH-ABND-GALGLSS.M482176	445
HWR2442P	581	HWR3072P	582	HWV75BBLP	587	SPLH-ABND-GALGLSS.M482177	445
HWR2448P	581	HWR3072PN	504	HWV75BBRP	588	SPLH-ABND-GALGLSS.M482178	445
HWR2448PN	503, 504	HWR3084P	582	HWV93AALP	587	SPLH-ABND-GALGLSS.M482179	445
HWR2454P	581	HWSA2	606	HWV93AARP	588	SPLH-ABND-GALGLSS.M482180	445
HWR2460P	581	HWSB2	606	HWV93BALP	587	SPLH-ABND-GALGLSS.M482181	445
HWR2460PN	504	HWSR24	607	HWV93BARP	588	SPLH-ABND-GALGLSS.M482182	445
HWR2466P	581	HWSR30	607	HWV95AALP	587	SPLH-ABND-GALGLSS.M482183	445
HWR2472P	581	HWSR36	607	HWV95AARP	588		

NOTES

NOTES

INFORMATION ON ORDERING PARTS

When parts are needed to repair HON products, the following guidelines should be followed to expedite the process.

1. Warranty orders are submitted on HON Ready via the Quick Claim tool. To purchase repair parts, please visit HONAccessories.com which can be found on HON.com.
2. There are no discounts applied to parts. Pricing quoted is the net value. Parts pricing is subject to change without notice.
3. For a part not covered by warranty applicable shipping charges will apply.
4. All keys are \$6.00 each plus a shipping and handling fee of \$3.00 per shipping location.
5. Parts may be paid for with an approved credit card. Approved Cards: MasterCard, VISA and American Express.
6. Payment terms for invoiced parts are Net 30 days.
7. Due to short leadtimes on parts, no changes will be accepted after the order has been placed.
8. When placing a **warranty** parts order:

If the product is under warranty, the product serial number must be provided. Most finished goods products have a serial number placed on them at the factory. The label containing the serial number is located:

Vertical Files — right side of the uppermost drawer

Lateral Files — left side of the uppermost drawer or shelf

Desk Towers — outside of top drawer

Desks, Credenzas, & Returns — on the outside, kneespace side of the top drawer. Fully extend the drawer to find it.

Desks, Credenzas, Corner Units, Bridges, Peninsulas & Returns without drawers — underside of top

Tables and Stands — underside of the top

Table Trucks — underside of side rail

Cabinets & Bookcases — left inner side of the case

Modular Component Top and Backs — underside of top

Modular End Panels — top inside surface

Reception Stations — top inside surface of back panel

Organizers — top inside surface of left end panel near back panel

Vertical Paper Manager — back panel inside surface near top

Pedestals — bottom drawer right side exterior

Seating — underside of the seat

Panels — underside of the top cap

Hutches, Storage Units, Overhead Storage — underside of the shelf

Hanging Bookshelves — underside of shelf

NOTE: Removal of the serial number tag from the product voids the warranty.

An important note regarding Product Serial Numbers:

HON desks, tables, chairs, files and systems components are tagged with a serial number. This number helps us identify *when and where your product was made*, and to identify and correct the root causes for the problem. NEITHER THE DEALER NOR THE CONSUMER SHOULD REMOVE THIS TAG UNDER ANY CIRCUMSTANCES. To do so immediately voids your Warranty coverage for that particular item *and prevents us from further identifying it*. Instead, please transcribe the number and call your Dealer.