



**OWNER'S MANUAL QUESTIONNAIRE**

Your suggestions are very important to us and we are continually striving to improve the quality of our manuals. After becoming familiar with your new recreational vehicle and the accompanying manual, please take the time to answer the following questions. When you are finished please return it, postage paid, to our Technical Publications Department. Feel free to attach an additional page if you desire.

**1. Is this your first recreational vehicle? YES / NO**

**2. Was the overall appearance and lay-out of this manual what you expected to see in your new recreational vehicle?**

---

---

---

---

---

**3. Was the information within this manual helpful in acquainting you with your new recreational vehicle? If not please address any area(s) we need to expand or improve on.**

---

---

---

---

---

**4. Were the operating instructions clearly written, and were you able to follow the steps without any difficulty?**

---

---

---

---

---

**5. Is there any additional information you would like to see incorporated within the owner's manual?**

---

---

---

---

---

**NAME:** \_\_\_\_\_ **PHONE:** (\_\_\_\_) \_\_\_\_\_

**ADDRESS:** \_\_\_\_\_



FOLD

FOLD



**Cut along  
the dotted  
line.**

**SECTIONS**

1

**WARRANTY & INFORMATION**

2

**DRIVING & SAFETY**

3

**CARE & MAINTENANCE**

4

**APPLIANCES**

5

**EQUIPMENT**

6

**WATER SYSTEMS**

7

**LP-GAS SYSTEMS**

8

**ELECTRICAL SYSTEMS - HOUSE**

9

**ELECTRICAL SYSTEMS - CHASSIS**

10

**CHASSIS INFORMATION**

**INDEX - PAGE 276**

## SIGNS

---



This sign indicates a NOTE.



This sign indicates a WARNING or a CAUTION with additional information attached.



This sign indicates INSPECTION is required.



This sign indicates ASSEMBLY/INSTALLATION or DISASSEMBLY/REMOVAL is necessary.



This sign indicates the specified part requires OIL/LUBRICATION.



This sign indicates a reference to the Warranty INFORMATION FILE located within the gray box inside your motorhome.

**Product information and specifications are shown herein as of the time of printing. Monaco Coach Corporation reserves the right to change product specifications, designs and standard equipment without notice and without incurring obligation.**

# Diplomat

## SECTION 1 WARRANTY & INFORMATION

<b>INTRODUCTION</b>	• 8
<b>CUSTOMER RELATIONS</b>	• 8
<b>TAKING DELIVERY</b>	• 9
<i>Monaco Responsibilities</i>	• 9
<i>Dealer Responsibilities</i>	• 9
<i>Customer Responsibilities</i>	• 9
<b>WARRANTY INFORMATION FILE</b>	• 10
<b>SERVICE SUGGESTIONS</b>	• 10
<i>Prepare for the Appointment</i>	• 10
<i>Prepare a List</i>	• 11
<i>Be Reasonable With Your Requests</i>	• 11
<i>No Looking Over the Technicians Shoulder</i>	• 11
<i>Inspect the Work Properly</i>	• 11
<b>REPORTING SAFETY DEFECTS</b>	• 11
<b>OWNER'S RECORD - PERSONAL PROPERTY</b>	• 12
<b>OWNER'S RECORD - INSURANCE</b>	• 12
<b>OWNER'S RECORD - SERIAL NUMBERS</b>	• 13
<b>LIMITED WARRANTY (Diplomat 2001)</b>	• 14
<i>Limitations of Implied Warranties</i>	• 14
<i>What the Warranty Covers</i>	• 15
<i>What We Will Do to Correct Problems</i>	• 15
<i>How to Get Service</i>	• 15
<i>What the Warranty Does Not Cover</i>	• 16
<i>Events Discharging Warrantor from Obligation Under Warranty</i>	• 16
<i>Disclaimer of Consequential &amp; Incidental Damages</i>	• 16
<i>Legal Remedies</i>	• 17
<b>VENDOR LIST</b>	• 18



## INTRODUCTION

This section contains warranty information and knowledge for the operation and care of the motorhome. Not all information may be applicable to your model of motorhome. More detailed information with CAUTION or WARNING instructions other than what is found in this section, can be found in the item's manufacturer manuals located in the owner information box.

In time, spotting wonderful little roadside locations by exploring off the main highway will become a regular event. There are many modern recreational vehicle parks (including state, county and federal parks) with nice facilities where you can obtain hook-ups for electrical, water and sewage connections. Directories are published which describe these parks and the availability of services and hook-ups. On overnight or weekend trips chances are you will not fill up the sewage holding tanks, deplete the water or LP-Gas supply or run down the batteries which supply the living area with 12 Volt DC current. On longer trips, when you have stayed where sewer connections and utility hook-ups were not available, it will be necessary to stop occasionally and empty the holding tanks and replenish the water and LP-Gas supply.

Many gas stations have installed sanitary dumping stations. Publications are available which list these dumping stations. When stopped for the night the Monaco motorhome is built to be safely parked in any spot that is relatively level and where the ground is firm. Try to pick as level a parking spot as possible. The motorhome is fully self-contained, all facilities are present.

The safety alert symbols mean **CAUTION** or **WARNING** for "Personal Safety Instructions." Read and understand the instructions where these symbols are displayed in this manual. Failure to comply with specific instructions may result in personal injury or death. Many instructions are required by National Safety Associations.

Only by ensuring your confidence and satisfaction with our products and services can we have continued success as a manufacturer of motorhomes. We believe a good relationship with our customers is just as important as improving the technical excellence of our products. Your authorized dealer is pleased to help you with instructions about your motorhome and to offer service when you need it. If problems remain after you have consulted your dealer you are invited to contact our Consumer Affairs Department. Please have all pertinent information (serial numbers, model number, etc.) when calling. We will work with the dealer and see that every attempt to resolve the matter is made.

## CUSTOMER RELATIONS

**Customer Service Department  
Monaco Coach Corporation  
91320 Coburg Industrial Way  
Coburg, Oregon 97408  
877-466-6226**



**TAKING DELIVERY**  
**Monaco**  
**Responsibilities**

Your motorhome has been manufactured to the highest quality and standards by factory trained personnel. Quality inspections are performed throughout the manufacturing process of your motorhome. Your motorhome has been carefully and almost completely hand assembled in our factory. Prior to the motorhome arriving at the dealership, all systems have been carefully tested and inspected to ensure optimum performance. The necessary forms and required manuals have been placed in the motorhome at the time of shipment to the dealership.

---

**Dealer**  
**Responsibilities**

The dealer must perform additional pre-delivery inspections and system checks, assist in the customer's understanding of the Limited Warranty and assist in completing any necessary forms. They must do a customer orientation to the motorhome, its systems, components and their operation.

The dealer should also ensure the customer receives a complete Owner's Packet with warranty cards and registrations for the motorhome and for separately warranted products, including detailed operating and maintenance instructions. The dealer is responsible for performing a review of the Limited Warranty provisions with the customer, while stressing the importance of mailing warranty cards and registrations to the manufacturers within the prescribed time limit to avoid loss of warranty coverage. They must assist the customer in completing these forms and locating serial numbers. They should request that the customer reads all warranty information when possible and explain any provision not clearly understood.

The dealer should instruct the customer on how to obtain local and out-of-town service on the motorhome and its various individual warranted components, whether the service is warrantable or out of warranty.

---

**Customer's**  
**Responsibilities**

As a new motorhome owner you are responsible for regular and proper maintenance. This will help you prevent conditions arising from neglect that are not covered by your Monaco Limited Warranty. Maintenance services should be performed in accordance with this Owner's Manual, and any other applicable manuals. As the owner it is your responsibility and obligation to return the motorhome to an authorized dealer for repairs and service (see Limited Warranty). Since the authorized dealer where you purchased your new motorhome is responsible for its proper servicing before delivery, and has an interest in your continued satisfaction, we recommend that Inspection, Warranty and Maintenance Services be performed by the dealership. We suggest that you take your new motorhome on a weekend shakedown before leaving on an extended trip.

**WARRANTY  
INFORMATION  
FILE**

In addition to this Owner's Manual there is a Warranty Information File in the unit. This file contains valuable documents about the motorhome's systems and equipment. Many of the components have manufacturer's warranty registration cards, which can be found in the Information File. Fill these cards out and mail them. Carefully read all the information in this file to safely operate, maintain and troubleshoot those items.

**MONACO COACH CORPORATION FINISH**

Because no two trees look alike authentic woods vary in color and character markings such as streaks, knots and grain patterns. Since the stains may attach differently to these grain patterns, some natural light and dark areas may result. The beauty lies in these natural variations of color and grain that give each cabinet its own individual charm.

The beauty of these products is protected with a furniture-quality exterior finish. After a period of time there may be minimal changes in the finish color as it ages in its surrounding conditions.

This is an inherent characteristic of this particular finish and the natural aging process adds to the unique appearance of the cabinetry.

Due to the minor differences in tone it may not be possible to match the finish color of existing cabinets exactly when replacing doors or adding additional cabinets at a later date.

**Monaco Coach Corporation**

The foregoing is not a warning. See Monaco Coach Corporation's Limited Warranty or call Monaco Coach Corporation at (877) 466-6226 for warranty information and limitations.

Know when to take your motorhome in for service. Give some thought to the appointment time. There are several things to consider when selecting a time for service. Location of the service center and the time of year can be a major issue. Monday and Friday are busy days for most dealers. Therefore, it makes sense to make a mid-week appointment whenever possible. Ask your dealer if additional time is needed for check in and completion of paperwork.

**SERVICE  
SUGGESTIONS**

If you're having warranty work done, be sure to have your warranty registration papers with you. All work to be performed may not be covered by the warranty; be sure to discuss additional charges with the service manager. Keep a maintenance log of your motorhome service history. This can often provide a clue to the current problem.

**Prepare for the  
Appointment**

**Prepare a List**

Make a written list of specific repairs needed. It is important the service manager be aware of all previous work which has been done on your motorhome. For example: if the motorhome has been repaired due to an accident. While this may not seem important, it could have a significant effect on the dealer's diagnosis of a problem.

---

**Be Reasonable  
With Your  
Requests**

Don't leave a list of 20 items to be serviced and expect to have your motorhome back by five o'clock. If you list a number of items, and you must have your motorhome back by the end of the day, discuss the situation with the service manager and list your items in order of priority. Some items may not be able to be repaired due to work loads or parts availability. Expect to make a second appointment for work not completed or for the long drawn out repair item.

---

**No Looking Over  
the Technicians  
Shoulder**

Please don't be offended when you are told you can not watch the work being done. Many service area insurance requirements forbid the admission of customers into the service work area.

---

**Inspect the Work  
Properly**

Check out the service or repair job when you pick up your motorhome and notify the service manager of any dissatisfaction. If circumstances prevent returning for immediate corrective work, make an appointment as soon as possible.

---

**REPORTING  
SAFETY DEFECTS**

If you believe that your motorhome has a defect which could cause a crash or could cause injury or death, you should immediately inform the National Highway Traffic Safety Administration (NHTSA) in addition to notifying Monaco. If NHTSA receives similar complaints it may open an investigation. If it finds that a safety defect exists in a group of motorhomes it may order a recall or remedy campaign. However, NHTSA cannot become involved in individual problems between you, your dealer or Monaco. To contact NHTSA you may either call the Auto Safety Hot line toll-free at 1-800-424-9393 (or 1-202-366-0123 in Washington DC area) or write to:

**NHTSA  
400 Seventh Street  
US Department of Transportation  
Washington, DC 20590**

**FOR YOUR OWN REFERENCE**

**OWNER'S RECORD - PERSONAL PROPERTY**

Item	Serial Number	Value
_____	_____	_____
_____	_____	_____
_____	_____	_____
_____	_____	_____
_____	_____	_____
_____	_____	_____
_____	_____	_____
_____	_____	_____
_____	_____	_____

**OWNER'S RECORD - INSURANCE**

Company \_\_\_\_\_

Policy Number \_\_\_\_\_

Agent's Name & Address \_\_\_\_\_

Business Phone \_\_\_\_\_

Emergency Phone \_\_\_\_\_

Renewal Date(s) \_\_\_\_\_

FOR YOUR OWN REFERENCE

OWNER'S RECORD - SERIAL NUMBERS



Refer to the Manufacturer's individual manuals for serial number locations that are not listed below.

Motorhome Serial Number \_\_\_\_\_

Motorhome Federal Vehicle Identification Number (VIN) \_\_\_\_\_

Door Key Number \_\_\_\_\_

Range Model & Serial Number \_\_\_\_\_  
(Located under top burner plate)

Microwave Model & Serial Number \_\_\_\_\_  
(Located behind door on case)

Refrigerator Model & Serial Number \_\_\_\_\_  
(Located inside refrigerator compartment)

Generator Model & Serial  
Number \_\_\_\_\_  
(Located in outside compartment on generator)

Roof Air Conditioner Model & Serial Number \_\_\_\_\_  
(Located under top cover on air conditioner)

**MONACO COACH CORPORATION LIMITED WARRANTY**

**What the Period of Coverage Is:**

If you use your Monaco motorhome only for recreational travel and family camping purposes, the Limited Warranty provided by Monaco Coach Corporation ("Warrantor") covers your new motorhome, when sold by an authorized dealer, for twelve (12) months from the original retail purchase date or the first 24,000 miles of use, whichever occurs first. However, the Limited Warranty provided by Warrantor covers the steel or aluminum frame structure of the sidewalls (excluding slide-outs), roof, and rear and front walls for sixty (60) months from the original retail purchase date or the first 50,000 miles of use, whichever comes first.

If you use your motorhome for any rental or commercial purposes whatsoever, the Limited Warranty provided by Warrantor covers your new motorhome when sold by an authorized dealer for ninety (90) days from the original retail purchase date or the first 24,000 miles of use, whichever occurs first. In addition, the Limited Warranty provided by Warrantor covers the steel or aluminum frame structure of the sidewalls (excluding slide outs), roof, and rear and front walls for twelve (12) months from the original purchase date or the first 24,000 miles of use, whichever comes first. A conclusive presumption that your motorhome has been used for commercial purposes arises if you have filed a federal or state tax form claiming any business tax benefit related to your ownership of the motorhome.

The above Limited Warranty coverage applies to all owners, including subsequent owners, of the motorhome. However, a subsequent owner must submit a warranty transfer form by filing the form through an authorized Monaco dealer. A subsequent owner's warranty coverage period is the remaining balance of the warranty coverage period the prior owner was entitled to under this Limited Warranty. Warranty transfer forms can be obtained by contacting the Consumer Affairs Department. There is no charge for the transfer.

**LIMITED  
WARRANTY  
- DIPLOMAT  
Model Year 2001**

**ANY IMPLIED WARRANTIES ARISING BY WAY OF STATE LAW, INCLUDING ANY IMPLIED WARRANTY OF MERCHANTABILITY AND ANY IMPLIED WARRANTY OF FITNESS FOR A PARTICULAR PURPOSE, ARE LIMITED IN DURATION TO THE TERM OF THIS LIMITED WARRANTY AND ARE LIMITED IN SCOPE OF COVERAGE TO THOSE PORTIONS OF THE MOTORHOME COVERED BY THIS LIMITED WARRANTY.** There is no warranty of any nature made by Warrantor beyond that contained in this Limited Warranty. No person has authority to enlarge, amend or modify this Limited Warranty. The dealer is not the Warrantor's agent but is an independent entity. Warrantor is not responsible for any undertaking, representation or warranty made by any dealer or other person beyond those expressly set forth in this Limited Warranty. Some states do not allow limitations on how long an implied warranty lasts, so the above limitation may not apply to you.

***Limitations of  
Implied Warranties***

**What the Warranty Covers**

The Warrantor's Limited Warranty covers defects in the manufacture of your motorhome and defects in materials used to manufacture your motorhome. Also see the section "What the Warranty Does Not Cover" set out below.

---

**What We Will Do to Correct Problems**

Warrantor will repair and/or replace, at its option, any covered defect if; (1) you notify Warrantor or one of its authorized servicing dealers of the defect within the warranty coverage period and within five (5) days of discovering the defect; and (2) you deliver your Motorhome to Warrantor or Warrantor's authorized servicing dealer at your cost and expense.

Warrantor may use new and/or remanufactured parts and/or components of substantially equal quality to complete any repair.

Defects and/or damage to interior and exterior surfaces, trim, upholstery and other appearance items may occur at the factory during manufacture. Normally, any factory defect or damage is detected and corrected at the factory during the inspection process performed by the Warrantor. If, however, you discover any such defect or damage when you take delivery of the motorhome, you must notify your dealer or Warrantor within five days of the date of purchase to have repairs performed to the defect at no cost to you as provided by this Limited Warranty.

If two or more unsuccessful repair attempts have been made to correct any covered defect that you believe substantially impairs the value, use or safety of your motorhome, you must, to the extent permitted by law, notify Warrantor directly in writing of the failure to successfully repair the defect so that Warrantor can become directly involved in performing a successful repair to the identified defect.

---

**How to Get Service**

The Warranty Registration form must be returned to Warrantor promptly upon purchase to assure proper part replacement or repair and to activate your Limited Warranty. For warranty service simply contact one of Warrantor's authorized service centers for an appointment, then deliver your motorhome (at your expense) to the service center. If you need assistance in locating an authorized warranty service facility, contact Warrantor's Warranty Department (1-877-466-6226). The mailing address is:

**Monaco Coach Corporation  
Warranty Department  
91320 Coburg Industrial Way  
Coburg, Oregon 97408**

In the event the motorhome is inoperative due to malfunction of a warranted part, Warrantor will pay the cost of having the motorhome towed to the nearest authorized repair facility provided you notify Warrantor prior to incurring the towing charges to receive directions to the nearest repair facility.

Because Warrantor does not control the scheduling of service work by its authorized servicing dealers, you may encounter some delay in scheduling and/or in the completion of the repairs.

---

This Limited Warranty does not cover: any motorhome sold or registered outside of the United States or Canada; items which are added or changed after the motorhome leaves Warrantor's possession; items that are working as designed but which you are unhappy with because of the design; normal wear and usage, such as fading or discoloration of fabrics, or the effects of condensation inside the motorhome; defacing, scratching, dents and chips on any surface or fabric of the motorhome, not caused by Warrantor; routine maintenance, including by way of example wheel alignments; the automotive chassis and power train, including, by way of example the engine, drivetrain, steering and handling, braking, wheel balance, muffler, tires, tubes, batteries and gauges; appliances and components covered by their own manufacturer's warranty including, by way of example the microwave, refrigerator, ice maker, stove, oven, generator, VCR, television(s), water heater, furnace, stereo, radio, compact disc player, washer, dryer, inverter and cellular phone; or flaking, peeling and chips or other defects or damage in or to the exterior or finish caused by rocks or other road hazards, the environment including airborne pollutants, salt, tree sap and hail.

***What the Warranty Does Not Cover***

---

Misuse or neglect, accidents, unauthorized alteration, failure to provide reasonable and necessary maintenance (See Owner's Manual), damage caused by off road use, collision, fire, theft, vandalism, explosions, overloading, and odometer tampering shall discharge Warrantor from any express or implied warranty obligation to repair any resulting defect.

***Events Discharging Warrantor from Obligation Under Warranty***

---

**THE ORIGINAL PURCHASER OF THE MOTORHOME AND ANY PERSON TO WHOM THE MOTORHOME IS TRANSFERRED, AND ANY PERSON WHO IS AN INTENDED OR UNINTENDED USER OR BENEFICIARY OF THE MOTORHOME, SHALL NOT BE ENTITLED TO RECOVER FROM WARRANTOR ANY CONSEQUENTIAL OR INCIDENTAL DAMAGES RESULTING FROM ANY DEFECT IN THE MOTORHOME.** Some states do not allow the exclusion or limitation of consequential or incidental damages, so the above exclusions may not apply to you.

***Disclaimer of Consequential & Incidental Damages***



***Legal Remedies***

**ANY ACTION TO ENFORCE THIS EXPRESS OR ANY IMPLIED WARRANTY SHALL NOT BE COMMENCED MORE THAN ONE (1) YEAR AFTER THE EXPIRATION OF THIS WARRANTY.** Some states do not allow the reduction in the statute of limitations, so the above reduction may not apply to you.

**THIS WARRANTY GIVES YOU SPECIFIC LEGAL RIGHTS, AND YOU MAY ALSO HAVE OTHER RIGHTS WHICH VARY FROM STATE TO STATE.**

**MONACO COACH CORPORATION  
ATTENTION: WARRANTY DEPARTMENT  
91320 COBURG INDUSTRIAL WAY  
COBURG, OREGON 97408  
1-877-466-6226**

## VENDOR LIST

### **Air Conditioner**

Dometic Corp.  
219-463-4858

### **Air Conditioner- Dash**

SCS/Frigette  
800-433-1740

### **Attic Fan**

Fan-Tastic Vent  
800-521-0298

### **Awnings**

Carefree  
800-621-2617

### **Bathroom Exhaust Fan**

Fan-Tastic Vent  
800-395-4045

### **Batteries**

Interstate  
800-272-6548

### **Carbon Monoxide & Liquefied Petroleum Protectors**

MTI Industries, Inc.  
800-383-0269

### **Cooktop**

Atwood  
800-873-4238

### **Engine**

Ford Roadside Assistance\*  
800-392-3673

\*Have VIN # available for service.

### **Entry Step**

Kwikee  
800-736-9961

### **Fire Extinguisher**

The Fire Extinguisher Co.  
919-563-4911

### **Generator**

Onan  
800-888-6626

### **GFI Outlet**

Kevco  
219-522-8820

### **Heat - Furnace**

Atwood Mobile Products  
801-972-4621

### **Hitch Receiver**

Reese Products  
219-164-7564

### **Inverter (Optional)**

Trace Engineering  
360-435-8826

### **Leveling Jacks - Hydraulic**

Power Gear  
800-334-4712

### **LP Gas Detector**

MTI Industries, Inc.  
800-383-0269

### **LP Tank**

Brunner  
800-753-8625

### **Microwave**

Sharp Electronics Corp.  
800-237-4277

**Monitor Panel**

KIB Enterprises  
219-294-1504

**Power Convertor**

Progressive Dynamics  
616-781-7802

**Power Heated Mirrors**

Velvac, Inc.  
800-783-8871

**Range**

Atwood Mobile Products  
219-262-2655

**Rear Vision System**

Jensen  
800-732-6866

**Refrigerator**

Norcold  
800-543-1219

**Seating**

Flexsteel Industries  
219-831-4050

**Slide-Out Motor**

Power Gear  
800-334-4712

**Smoke Detector**

Bob Gun Associates  
616-467-8705

**Television/VCR**

RCA  
800-545-2672

**Television Antenna**

Wingard  
319-754-0600

**Tires**

Goodyear Tire & Rubber  
800-399-2772

**Toilet**

Sealand  
800-321-9886

**Water Heater**

Atwood Mobile Products  
219-262-2655

**Water Pump**

Shurflo  
800-762-8094

**Windshield Wipers**

Diesel Equipment  
336-373-8331

**Water Filter**

Everpure, Inc.  
800-323-7873

# Diplomat

## SECTION 2 DRIVING & SAFETY

- DRIVING SAFETY • 24**
  - Inspections • 24*
  - General Condition • 24*
  - Check the Engine • 24*
  - Inside the Motorhome • 24*
  - Familiarize Yourself • 25*
  - Safety Seat Belts • 25*
  - Tips for Driving • 25*
- CHECKLIST - Opening the Motorhome • 26**
- CHECKLIST - Ready to Leave • 29**
- CHECKLIST - Items to Carry • 29**
- CHECKLIST - Winter Storage • 30**
- STORAGE - Long Term • 31**
- DRIVING - Parking • 34**
  - Backing Up A Motorhome • 34*
  - Rear View System • 37*
  - Hitch - Using the Rear Hitch • 37*
  - Tow Plug Connection • 38*
- EMERGENCY PROCEDURES • 38**
  - Transmission - Rocking Out • 38*
- TOWING PROCEDURES • 39**
  - Brake - Disabling the Parking Brake • 39*
  - Towing Without A Stinger • 40*
  - Light - Retractable • 40*
- CHECKLIST - Set-up Procedures • 41**
- DRY CAMPING TIPS • 41**
- GFCI BREAKERS & OUTLETS • 43**
- SMOKE DETECTOR • 44**
  - How to Test • 44*
  - Maintenance • 44*
  - Troubleshooting • 44*
- LP-GAS DETECTOR • 45**
  - Operation • 45*
  - Testing • 45*
  - Alarm • 46*
  - Care • 46*
- CARBON MONOXIDE DETECTOR • 47**
  - Operation Instructions • 47*
  - Alarm • 48*
  - Testing • 48*
  - Cleaning • 48*
- FIRE EXTINGUISHER • 49**
- EGRESS EXIT WINDOW • 49**
- TIRES & WHEELS • 50**
  - The Importance of Air Pressure • 50*
  - How Much Air Should I Carry in My Tires? • 50*
  - How to Determine the RV's Correct Weight • 50*
  - Where to Weigh the Motorhome • 51*
  - How to Weigh the Motorhome • 51*
  - Tires - Inspection • 52*
  - Blocking - When Leveling • 52*
  - Tire - Long Term Storage • 52*
  - Care & Maintenance of Aluminum Wheels • 53*
  - Tire - In Case of Flat Tire • 54*
- INFLATION & WEIGHING • 55**
  - When to Check the RV's Tire Pressure • 55*
  - Tire Rotation • 56*
- WEIGHT TERMS • 57**
- WEIGHING THE MOTORHOME • 59**
  - Tire Chart • 63*
- VIEWS - Front & Rear • 64**
- VIEWS - Curbside & Roadside • 65**



## DRIVING SAFETY

There are differences between your motorhome and passenger automobiles. You should always be aware of those differences.

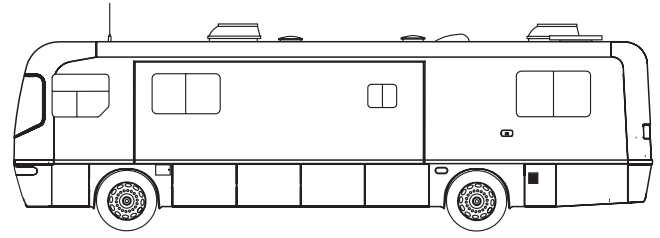

The key for safely operating your motorhome is inspection. Any defect found could result in problems on the road that will cost time and money. There are several states that require your motorhome be inspected prior to registration. A systematic inspection conducted prior to moving your motorhome will ensure nothing is overlooked. This also assists you in becoming familiar with the motorhome. Start by looking at the general condition and the area around your motorhome for hazards to the movement. Look high and low as you walk around your motorhome.

### ***Inspections***

#### ***General Condition***

- The power cord is disconnected and stowed.
- The water hose is disconnected and stowed.
- TV/satellite antenna fully retracted resting in the cradle.
- Awnings stowed and locked in place.
- All compartment doors closed and latched.
- All the leveling jacks fully retracted.
- Any obstacles to avoid when driving off.
- Slide room moved inward.
- Wheels and tires inspected.
- No puddles or fluid leaks under the coach.
- No physical damage.
- Check entry door access.

#### ***Check the Engine***

- Check fluid levels for improper level.
- Check belts and hoses for wear.
- Check wiring for loose and frayed connections.
- Check for fluid leaks on engine or transmission.
- Start engine and listen for noises.

#### ***Inside the Motorhome***

- Gauges and controls all operating and functioning properly.
- All windows and vents closed.
- All cabinet doors and drawers closed.
- All interior lights switched OFF.
- All items secured.

## **Familiarize Yourself**

From the driver's seat perspective you will notice that you are sitting up higher and further to the left than in a passenger automobile. Your perspective of the road will therefore be different. Because of the driver's seat location and the configuration of the motorhome, rely on outside mirrors to line the motorhome up with your lane and to check conditions behind you. The dashboard may contain more gauges and controls than are normally found in passenger automobiles. Become familiar with these devices and how they operate before starting out.

---

## **Safety Seat Belts**

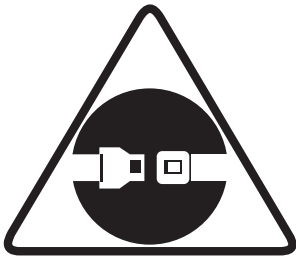

All occupants must be furnished with and use seat belts while the motorhome is moving. Driver's seats and all other seats designed to carry passengers while motorhome is in motion are equipped with safety seat belts. While traveling, do not occupy beds or any seats that are not equipped with safety belts. Seat belts must only be used on permanently mounted seats. The driver's seat must be locked in the forward facing position while the motorhome is in motion. Do not use a seat belt on more than one person.

To fasten the seat belt, pull the belt out of the retractors and insert the tab into the buckle. You will hear a click when the tab locks into the buckle. Seat belt lengths automatically adjust to your size and sitting position. Do not route belts over armrest.



**WARNING: Seat must be pointed in a forward position and seat belts fastened while the motorhome is in motion. Avoid seat rotation while in transit. Children must not be transported unrestrained. Infants must be placed in approved safety seats. Small children must be restrained in child safety seats. Failure to comply with these rules can cause injury or death.**

---

## **Tips for Driving**

Consider many factors when operating a motorhome. Because a motorhome is longer than the average automobile the turning radius will be wider; therefore, it is always a good idea to be cautious when turning the motorhome. Keep a close eye on the rear of the motorhome, making sure it will clear potential obstacles. The motorhome is also heavier than an average automobile, with a higher center of gravity. Those factors may make it difficult to change the momentum of your motorhome. Making sharp turns or swerving, especially at high speeds, could result in the loss of control of the motorhome.

The safe control speed of the motorhome will vary with road conditions, grade of the road and size of the load. Keep that in mind and drive with the extra caution necessary to avoid situations which might require quick momentum changes. The motorhome will travel safely and comfortably at highway speed limits; however, it will take longer to reach that speed. Always keep in mind when overtaking and passing another vehicle, due to the length of the motorhome it takes a greater distance and time to pass another vehicle. Allow plenty of time to safely pass another vehicle.

When descending a long hill, drop down into a lower gear. The transmission and engine will help control downhill speed and can lengthen brake life. The distance required to stop the motorhome will be greater than that of an automobile. Even though your motorhome is equipped with brakes designed for the Gross Vehicle Weight Rating (GVWR), we suggest that you practice stopping away from traffic until you become accustomed to your motorhome's stopping distance.

When backing up have your co-pilot get out of the motorhome and walk to the driver's side rear corner. The co-pilot can watch for any obstacles and give hand signals to you as you back up.

When traveling make sure any bridges you cross can support the weight of your motorhome. Check the tonnage limit of bridges before crossing them. Signs are normally posted at bridge entrances. Know and observe the laws where you will be traveling as they may vary from state to state.

---

If the motorhome was properly and carefully prepared for storage taking it out of storage will not be difficult. The following procedure checklist assumes that you stored your motorhome properly. If you did not, and extensive freeze damage or other serious deterioration has occurred, consult a dealer or an authorized service center for advice.

**CHECKLIST-**  
***-Opening the***  
***Motorhome***

- Thoroughly inspect the outside of motorhome. Look for animal nests in the wheel wells or in other out of the way places.
- Remove all appliance vents, ceiling vents and air conditioning covers. Be sure all refrigerator openings are free of debris, insect nests, webs, etc.
- Open all doors and compartments. Check for animal or insect intrusion, water damage or other deterioration.
- Check all chassis fluids levels: engine oil, engine coolant, hydraulic fluid reservoir, transmission oil and rear axle oil.
- Check the charge levels in the batteries. Refill with distilled water only and recharge as necessary. Reinstall the batteries if necessary.
- Be sure the cable ends and terminals are clean and free of corrosion.
- Be sure the engine instruments indicate proper readings. Start the engine, allowing it to reach operating temperature.
- Shut the engine down. Check all fluids and fill as necessary.



- While the engine is running check the operation of head-lights, tail lights, turn signals, back-up lights, license plate light and emergency flasher. Operate the dash air conditioner. If the air conditioner does not work, or unusual sounds occur, have the system checked by a qualified air conditioner technician.
- Drain, flush and sanitize the fresh water system as outlined in the water section (4). Inspect the drain hose for leaks. Replace if necessary.
- Operate all faucets and fixtures in the fresh water system.
- Check for water leaks at all joints and fittings. Repair if necessary.
- Check the 12 Volt circuit breaker and inspect fuses.
- Operate all 12 Volt lights and accessories.
- Install the new batteries in battery operated devices.
- Test the carbon monoxide, LP-Gas and smoke detectors.
- Check the monitor panel operation.
- Inspect the 120 Volt electrical system which includes the power cord, converter, all outlets and exposed wiring. If defects are found refer to your dealer or an authorized service center.
- Start and run the generator.
- Operate the 120 Volt appliances and air conditioners.
- Inspect the LP-Gas system and check for leaks. If the LP tank shows signs of rust or corrosion have it inspected by a qualified LP technician.
- Operate each LP-Gas appliance. Observe all burner/pilot flames for proper color and size. In any case, have the LP-Gas regulator adjusted for proper pressure by a qualified technician.
- Inspect and clean the interior.
- Check the sealant around all roof and body seams and windows. Reseal if necessary.
- Lubricate all exterior locks, hinges and latches.
- Check the windshield wiper blade condition. Check the wiper/washer operation.
- Wash and wax the exterior. Inspect the body for scratches or other damage; touch up or repair as necessary. Flush the underside thoroughly.
- Run through the operational checks for steering, brakes, engine and transmission. Operate the motorhome slowly

during these checks to allow sufficient circulation of fluids and resetting of the components.

- If you choose, your dealer can double check your preparation and correct any defects or make any necessary adjustments.



**Prepare the generator for operation following the instructions in the Generator Manual.**

## CHECKLIST- Ready to Leave

- Drain and flush out the holding tanks. Close the valves and install the cap securely.
- Disconnect the sewer hose, flush with clean water and store it in an outside compartment.
- Fill the fresh water tank. Disconnect and store the fresh water hose.
- Disconnect the shore line and rewind it.
- Disconnect the cable TV and phone hookups and lower the TV antenna.
- Retract any awnings and secure them for transport.
- If applicable, lower the satellite dish.
- Close all roof vents.
- If applicable, retract the leveling jacks to their travel position.
- Check the engine oil, transmission fluid, engine coolant, power steering fluid, windshield washer fluid and tire inflation.
- Secure any loose, heavy or sharp objects in the motorhome or its service compartments.
- Turn off the interior lights, water heater, furnace and water pump.
- Check the LP-Gas tank gauge to make sure there is LP-Gas available.
- Check the fuel gauge and lights on the motorhome.
- Fasten bi-fold and pocket doors securely.
- Walk around your motorhome one last time to make sure everything is stored away and outside compartments are closed and locked.
- Visually check the front oil bath hubs and fluid level to insure that there are no leaks (**if applicable**).
- Pull forward, clean the site (if necessary) and check for forgotten items.
- Secure and lock the entrance door.

## CHECKLIST- Items to Carry

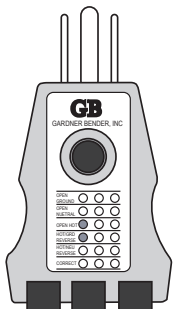

110 Tester

- 12 Volt DC test light. This may be helpful on the phone with a technician.
- Battery hydrometer, to check each battery cell during maintenance.
- One 12-Volt continuous duty solenoid.
- An assortment of spare fuses.
- One link kit for ride height control assembly.
- A spare alternator belt.
- Hump hose clamp for the Charge Air Cooler.

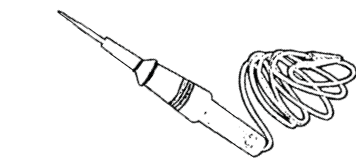

Test Light

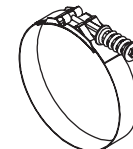

T-Bolt Clamp



Height Cont Link

## CHECKLIST- Winter Storage

- **Plumbing Lines** - Drain and protect by filling with approved RV antifreeze.
- **Fresh Water Tank** - Drain.
- **Body** - Clean and wax. Oil locks and hinges. Repair roof seams as needed.
- **Countertop and Cabinets** - Wash with mild soap and water.
- **Curtains** - Remove and clean according to care specifications.
- **Windows** - To protect the interior fabric from fading, cover windows by pulling blinds, closing shades or using a separate cover such as a sheet.
- **Holding Tank** - Drain and rinse. Close valves.



**Add a small amount of antifreeze to keep valves and gaskets lubricated.**

- **Drain Traps** - Pour RV antifreeze down all drains.
- **Batteries** - Add distilled water and recharge if needed. Disconnect the cables. Remove the batteries and store them in a cool dry place. Check and recharge as needed. Never park the coach where the battery door cannot be opened.
- **Refrigerator** - Clean and leave both doors propped open. Cover the exterior panels and roof vents.
- **Air Conditioner** - Remove the air filters. Clean or replace.
- **Roof** - Keep clear of snow accumulation or damage may occur.

## STORAGE- Long Term

Long term storage of the motorhome can be defined as leaving a motorhome unattended for a period of thirty days or more. A motorhome requires protection from the elements just as a house or a car would. When left out in the environment without proper storage or maintenance a motorhome, house or car is vulnerable to the moisture and oxidation process inherent in the environment.

There are preventative measures which should be taken and preferable situations to use when storing a motorhome. Such measures will aid in protecting and preventing a motorhome from the damaging effects caused by an accumulation of moisture.



**NOTE: The natural process of moisture in the air condensing will occur with temperature changes of 30° Fahrenheit or more in one day. Humidity readings of 60% or greater will allow the accumulated moisture to remain for extended periods of time.**

**If the motorhome is stored in a location where AC power is not available:**

- Turn off all appliances.
- If possible, situate the motorhome so the batteries remain accessible. This allows a battery to be charged or replaced without moving the motorhome.
- Charge the batteries to a full state of charge.
- Turn the main battery disconnects to OFF.
- When stored outside use the available DC volt meters to make a quick reference check of the batteries while the motorhome is in storage. If the motorhome is stored outside solar panels may offset the parasitic loads.
- Preventative measures should be used if the voltage readings are low. By using preventative measures, bringing the motorhome out of storage or moving the motorhome in case of an emergency is a much easier process.



**NOTE: Batteries in a low state of charge will readily freeze. Freezing will damage the battery.**

**If AC power is available:**

- Both main battery disconnect switches will remain ON. The inverter will charge both the house and engine battery banks. A 30 amp shore power service will be more than adequate.



**CAUTION: A 20 amp service using light duty extension cords and the required adapters create serious voltage losses. Line voltage loss and the resistance at each electrical connection is a hazardous combination and should be avoided. Damage to sensitive electronic equipment may result!**

**Type of surface to park and store the motorhome on:**

The type of surface the motorhome is parked upon will have an affect on how much moisture accumulation occurs on the chassis and flooring. Moisture can eventually seep into the interior.

- A gravel covered parking area still allows moisture to evaporate from the ground, through the gravel and to the underside of the motorhome.
- Concrete pads seal the surface, allowing better ventilation under the motorhome.
- Storage buildings with concrete floors or heated storage facilities greatly reduce the amount of moisture accumulation and protects the motorhome from moisture damage.

**If the motorhome is stored outdoors:**

- The interior should be heated to help prevent mold and mildew growth. Moisture removing desiccate filter systems are available from hardware and RV supply stores. Place the filter system inside the motorhome to reduce inside moisture condensation or humidity. These systems help control mold and mildew growth.
- Proper winterization of the fresh water system will prevent potential damage in extreme cold.
- Ultraviolet radiation affects soft goods and rubber products such as: privacy curtains, window shades and tires. These items should be protected.
- Cardboard templates can be made for the windows to protect these items from exposure to direct sunlight.
- Tire covers are available to protect the sidewall of the tires from cracking. Make sure the tires contain the correct air pressure. Underinflated tires can be damaged.
- Washing the exterior regularly will help control moss accumulation. The clear coat has UV protective substances. Waxing the motorhome twice a year will augment these substances.

**Inspect the motorhome:**

- Perform a full interior inspection for water leaks every two weeks while the motorhome is in storage. Open all cabinet doors looking for signs of dampness or leaks. Inspect the ceiling areas around roof vents or other roof openings.
- The roof and sidewall seams should be inspected and cleaned at least twice a year. Inspect for exterior sealant gaps of all roof seams, vents, skylights, roof air conditioners and windows. If necessary, use the proper sealants and recommended application procedures.

**Fuel:**

- A full tank of fuel will help moisture from condensing at the top of the tank. Diesel fuel is an organic material which will develop a microbe growth (black slime). Fuel stabilizers may be added to help prevent the microbe growth. Consult the Cummins manual or a Cummins distributor for further detailed information on fuel stabilizers and additives.

**Brakes:**

- Brakes also suffer from non-use during periods of storage. The bare metal machined surfaces of brake drums or rotors have only a light coating of dust from the brake lining friction material. The brake dust is the only thing protecting the bare metal surfaces from rusting. Only regular brake applications dry the moisture preventing rust on brake drum or rotor surfaces. During periods of non-use, oxygen and moisture oxidize the machined surfaces. Only occasional use keeps these surfaces from oxidizing. Rusty brake drum or rotor surfaces permeate the brake linings upon the first few applications, reducing the friction action of the linings.

**Engine:**

- Internal combustion engines need to be “exercised” on a regular basis. This will ensure that an adequate supply of lubricating oil coats the cylinder walls and piston rings. Valve and valve seat surfaces also suffer from non-use. Some valves will remain open depending at which part of the combustion cycle the engine has stopped. The heat and cold of the day allows moisture to accumulate through the exhaust system.

**Electric Motors:**

- Electric motors in the motorhome should be operated occasionally to help lubricate and keep surfaces rotating freely. These items include the roof air conditioners, dash fans, dash blower motor, furnace, heat exchangers and powered roof vents.

Put the motorhome gearshift in neutral and set the parking brake. Turn off the ignition switch. Block all four wheels securely. Level the motorhome as directed under "Leveling Jacks." Connect 120/240 AC power.

- 50 Amp service is what the motorhome is equipped with to operate all electrical equipment.
- 30 Amp service motorhomes will be able to operate, but with some limits.

Open the LP-Gas tank valve. Connect the fresh water supply. Connect the waste drain hose to sewer hook-up. If applicable, start the refrigerator, water heater and furnace. Most appliances should be operated on gas at first. Once the motorhome is plugged into shore power the inverter will go into a 90 minute bulk rate charge. Determine later what appliances will be run on 110/12 Volt power.



**NOTE: Chock all the wheels securely if you are leaving the motorhome.**

Whether you are a long time owner of recreational vehicles or just starting out, backing up can be a challenge. Following some simple guidelines may help reduce the challenge. When backing up the driver (pilot) should be comfortable using the mirrors, the back-up camera and the co-pilot's directions (ground guide) for assistance. Practice first, backing up with the co-pilot's guidance in a large unobstructed parking lot. It is a team effort.

The backing up process should begin while the motorhome is in forward motion. Maneuver the motorhome to align it with the chosen site. This allows straight alignment with the site. Aligning the motorhome with the site after the backing process begins will require considerably more room than an automobile, and may require more than one attempt. When the motorhome is properly aligned with the site, the parking area will be visible in both mirrors. Use straight lines, such as road markings, as reference points when possible.

The co-pilot will perform just as important a job as the driver. When guiding the driver the co-pilot should be located safely at the left rear corner of the motorhome, facing forward, while remaining visible in the driver side mirror at all times. The co-pilot should make a conscious effort to maintain sight of the driver through the driver side mirror as the front of the motorhome maneuvers. If the driver loses sight of the co-pilot stop the backing up process until the co-pilot returns to view. To avoid mishaps the co-pilot should be focused only on what the driver is doing, with brief observation moments. The driver should receive directions only from the co-pilot. If necessary, stop the backing up process to have co-pilot inspect other areas or angles of concern. Use of walkie-talkies will aid in guidance.



When co-pilot is guiding the driver only five clearly defined signals should be used, with only one signal given at a time. Flailing arms with indecisive signals only confuse the driver. Signals should be given with purpose and confidence. Directional signals are directing travel of the rear of the motorhome.

If desired direction is left, the co-pilot points left. For example: The co-pilot will use his/her right arm and forefinger pointing distinctly left with arm and finger held on a horizontal plane, indicating desired direction of travel of the rear of the motorhome. This type of directional signal is easily discerned in the mirror by the driver. The directional signal given will remain steady until desired movement is completed.

**The five directional signals are:**

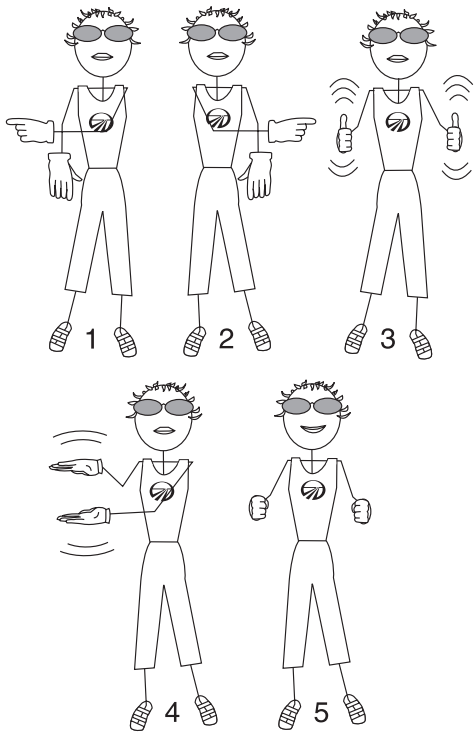

1. Co-pilot uses left hand and arm held horizontal, with forefinger pointing right, to direct rear of motorhome to the right.
2. Co-pilot uses right hand and arm held horizontal, with forefinger pointing left, to direct rear of motorhome to the left.
3. Co-pilot uses both arms and hands parallel with thumbs pointing up and to rear in a waving vertical motion. This signals driver to maintain a straight back direction.
4. Co-pilot holds arms vertically, hands open with palms facing one another. Start with a wide separation, gradually closing distance of hands, in a rate appropriate to vehicle speed, to indicate amount of distance to stop point.
5. Closed fists indicates STOP.

Trailers have only one pivot point. Trailers may be backed up. Towed vehicles using a tow bar or tow dolly have more than one pivoting point. This makes this type of equipment not suitable for backing. If using this type of towing equipment, plan ahead. Park safely along the road and walk a distance if necessary to avoid a possible back up situation. Try to avoid putting the motorhome and tow vehicle in a backing situation. The only way to back up this combination is to completely disconnect the tow vehicle from motorhome. Trying to back up this combination, even as small as a foot, will result in damage to the motorhome, tow vehicle and towing device.

The same rules for backing a motorhome may be applied when backing a trailer. When preparing to back a trailer into a space maneuver the motorhome

sweeping wide, then turn back to the opposite direction. This will set the motorhome and trailer in a position to maneuver the trailer into space. When backing a trailer the driver may become disoriented with the direction of the steering wheel and the direction of the trailer. A trick here is to move the bottom of the steering wheel in the desired direction of the trailer. For example: If the desired direction of the trailer is left, rotate the bottom of the steering wheel left. If the trailer moves in an undesired direction, use a short “pull-up” method, pulling forward just far enough to align the trailer with the space. The co-pilot should stand safely at the left rear corner of the trailer within view of the driver in the driver side mirror, using the five hand signals for guiding.



**CAUTION: Tow bars or car dollies generally are made to travel in a forward direction only. Most towing equipment of this type is not designed for backing. Never attempt short back up distances with a tow bar or tow dolly. Damage to the motorhome, vehicle or towing device will result.**

If your destination does not have “pull-through” sites try to pick a solid, level site. If possible, pick a site located on the left side. This is the preferred side. The driver will have a better field of vision by using the driver side mirror. If the site is on the right side the driver will have to use the passenger side mirror for backing up, which leaves a blind spot. When a potential site is spotted, stop the motorhome before the site. Get out and observe the area for soft ground, posts, large rocks, low hanging limbs or other obstacles. If the site meets your particular criteria, prepare to back in carefully. Have the co-pilot guide you using the five hand signals.

## Rear View System

The motorhome is equipped with a rear vision system. This system is designed to provide the driver with a view of the rear of the motorhome. The rear vision system consists of a monitor on the dash and a camera at the rear of the motorhome. The monitor is equipped with several adjustable features:

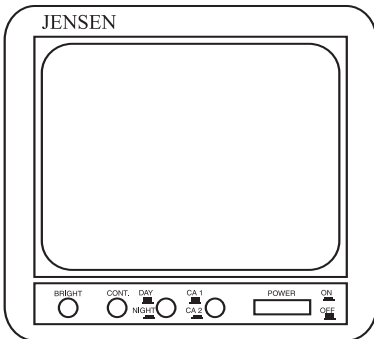

- Contrast and brightness settings
- Day/night dimmer control

The driver can see what is behind the motorhome. The rear vision system will automatically turn ON when the gear selector is placed in reverse. Turning the main power switch to ON will allow continuous operation of the rear vision system when the ignition key is turned ON. For more detailed instructions see the manufacturer's manual.

## Hitch - Using the Rear Hitch

When using rear hitch remember that the motorhome is intended for towing light loads. The motorhome is designed to be used primarily as a recreational vehicle, towing will affect durability and economy. Your safety and satisfaction require proper use. Avoid excessive loads or any other abuse. Do not use the motorhome to tow anything until it has been driven 500 miles (800 kilometers). Weight pushing down on the rear hitch must not exceed 1,000 pounds. We recommend weighing the motorhome as it will be operated to be certain that there is proper weight distribution. When weighing the motorhome be sure to take the passenger locations into consideration. Total weight of the motorhome and any vehicle towed by it must not exceed the GCWR.



**WARNING: Any trailer being towed by a motorhome must have adequate brakes. Failure to follow these instructions will create a safety hazard and may result in an accident.**

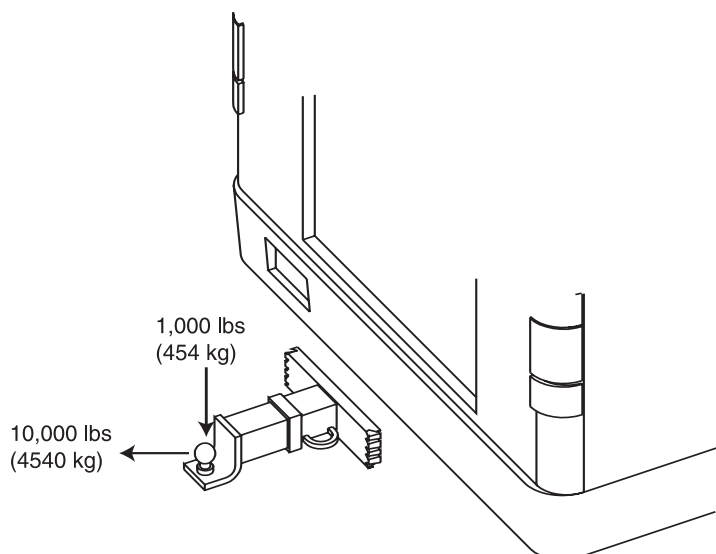

The motorhome is prewired with a trailer plug harness. The harness is located on or near the hitch receiver. Convoluted tubing protects the tow harness wires until they are ready for use. Current draw should not exceed ten amps for each designated circuit.

## **Tow Plug Connection**

### **The tow harness wires are color coded:**

1. Brown, 12 gauge - tail lights.
2. White, 12 gauge - ground.
3. Black, 14 gauge - right turn signal.
4. Yellow, 14 gauge - left turn signal.
5. Black w/white stripe, 14 gauge - brake light.

When hooking up a tow plug connection you should strip the wires 3/8". Twist the wire and place under the clip and secure the screw. Make sure there are no loose strands of wire which could short against the case or other terminals.

Always carry road flares or reflective warning signs to display if necessary. Pull off roadway as far as possible for emergency stopping or tire changing. Turn your motorhome hazard warning flashers ON when parked alongside traffic lanes. Set the parking brake.

## **EMERGENCY PROCEDURES**

It may be possible to rock the motorhome out if you are stuck in snow, mud or deep sand. Shift the selector to D (Drive) and apply steady light throttle. Never full throttle as you may spin the wheels and bury yourself deeper. When the motorhome has moved forward as far it will go, apply and hold the service brakes. Allow the engine to return to idle before selecting the R (Reverse). Release the brake and apply light throttle until the motorhome has rocked as far it will go. Again, apply the service brake and allow the engine to return to idle. Repeat this process if the motorhome has moved a greater distance. If the process does not free the motorhome call for towing assistance.

### **Transmission -Rocking Out**



**NOTE: Sudden movements or lurching the motorhome with an open throttle can result in damage to transmission. Avoid this condition by making shifts only when the throttle is closed and engine is at normal idle.**

## TOWING PROCEDURES

It is recommended that if a towing company is called make sure they use a stinger (an arm that goes under motorhome and hooks to front cross member).

The towing company may need to locate the air nipple to release the air brakes. The air nipple is located in the outside roadside front electrical compartment and should only be used by towing personnel. If the motorhome ever needs to be towed, use the following instructions:

- Secure any loose or protruding parts if the motorhome is damaged.
- Inspect points of attachment on a disabled motorhome. If attachment points are damaged, select other attachment points at a substantial frame structural member.
- Never allow anyone to go under a motorhome while it is being lifted by towing equipment unless the disabled motorhome is adequately supported by safety stands.
- Do not tow the motorhome from the rear. Towing from the rear will cause the front tires and suspension to be seriously overloaded, possibly resulting in a tire or front suspension failure. Rear frame extensions are not designed to withstand loads imposed by lifting the rear of the motorhome.
- If rear wheels are disabled, place the motorhome on a flat bed trailer or use a heavy duty dolly under the rear wheels and tow from the front of the motorhome.
- The drive shaft must be removed to protect transmission.



**WARNING: In the event the motorhome requires towing ensure all precautions are followed. The driveline must be disconnected and the mudflap may need to be removed. Damage to the motorhome from a towing company will not be covered by Monaco Coach Corporation.**

### Brake - Disabling the Parking Brake

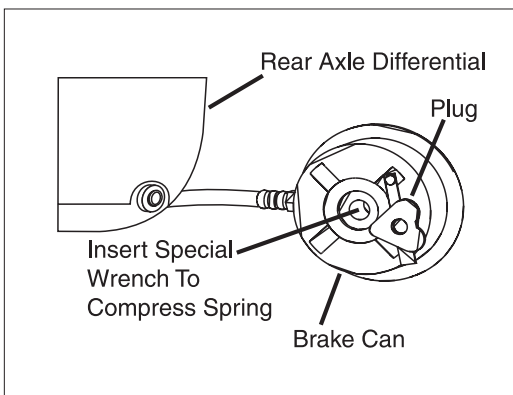

- Block wheels securely before attempting this procedure.
- Remove the plug from the center of rear brake can.
- Remove the caging tool from its holder on the rear brake can and insert it into the hole. Turn the tool clockwise to engage.
- Use a wrench to tighten the nut down, which compresses the internal spring, releasing the brake.
- Repeat for the other side.
- After towing, or when air pressure is again available, loosen the nut and remove the tool. Return the tool to its original location and replace plug.
- Repeat for the other side.



**WARNING: Do not attempt to disassemble brake canisters without special tools and without having studied specific manufacturer's instructions. Canisters contain springs under very high tension. Improper handling could result in component damage or personal injury.**

## Towing Without A Stinger

Make sure the tow truck can safely pull the weight of the motorhome. Give the towing company the weight of your motorhome when you call them. If your motorhome is going to be towed without a stinger do the following:

- Wrap chains around both A-arms or the front axle on each side.
- Pass the chains beneath the tow bar below the bumper.
- Position a 6" x 6" piece of lumber between the ends of main frame rails and the tow vehicle transfer plate to maintain clearance to body parts.
- Attach safety chains, which are completely independent of the primary lifting device, to the main frame rails.
- When the motorhome is under tow allow enough room between the front of the motorhome and the rear of the tow vehicle while turning corners.

1. Activate the light by moving the ON/OFF switch to the ON position.
2. The light is on an 18' retractable reel cord. To operate, lift the lever and pull the light out.
3. The light has a magnetic base attached. Locate a place to attach the light so you can work hands free.
4. To replace the bulb push down on the clear plastic cover and twist.
5. To rewind, crank the handle in the retract direction. Once it is fully inward you will need to push down on the lock handle to keep the light locked into place.

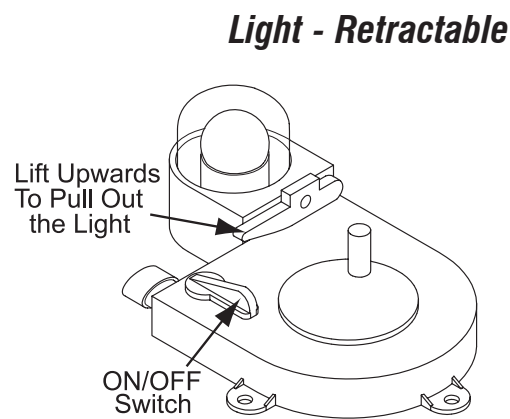

Retractable Reel Light.

## CHECKLIST- Set-up Procedures

If the site for the motorhome has full hook-ups use this quick reference hook-up checklist. This hook-up list is only a guide. For detailed information look in the section pertaining to the item of interest.

- Prepare the shore cord to be plugged in. Uncoil and inspect the cord. Perform any necessary cord maintenance. Install proper electrical adapters if anything other than 50 amp service is provided. Turn power supply circuit breaker OFF before plugging in the shore cord.
- If cable service is provided, hook a 75 Ohm or RG6 cable to the cable connection in the service center. If the motorhome has a video selector box, press the CABLE view button for item desired.
- A phone jack hook-up is provided in the service center. Phone outlets are placed throughout the motorhome, including a phone line to the satellite receiver.
- Hook a potable water hose to the city water connection in the service center. A water pressure regulator is built in. Turn the hand valve so the pointer indicates “city water.”
- Sewer drain pipe diameters are generally either three or four inches. Proper sewer hose adapters will ensure against leaks or spillage. With the sewer hose properly connected, open the grey water valve (small valve). The black water valve (large valve) remains closed until the tank is full or until time of departure.



**NOTE: When dumping the black tank, first close the grey water valve and fill the tank 50%. Open black tank valve until the drain cycle is complete. Use a non-potable water hose when using the black tank flush system. Close the black tank valve, then open the grey water valve. Solids will be flushed from the drain hose.**

## DRY CAMPING TIPS

For extended dry camping, management of all resources is essential. The motorhome has large batteries, plenty of water and large holding tank capacities. With a little care and forethought it is possible to go a long way with only the wonderful amenities you bring with you.

Conserve water! Your motorhome holds a lot, but it goes down the drain fast. Don't waste water you don't actually use. Use a manual valve on shower head and turn the water off and on as needed while showering. You can reduce water needed for a shower by as much as two-thirds. Don't let water run in sink while you do other things, such as wiping up kitchen or brushing your teeth.

Conserve battery power. Use electricity sparingly. Turn off the inverter when it is not in use. Only turn it on when you need it. However, remember that when



the generator is running the inverter will come on automatically.

Charge the batteries when they are half down. At half charge the battery voltage will be 12.2 Volts. You can use a hydrometer for testing. A good rule of thumb is to run the generator for three to four hours daily, which should supply enough power. Never try to use batteries until they are completely dead, or when the lights "dim out." Each time the batteries are used at half charge, the ability to recharge up to full capacity is diminished. The damage that occurs is cumulative and will eventually render a battery useless.

If you are in a habit of starting the engine regularly remember that the alternator output is lower at an idle, and that even at a fast idle it may take as much as an hour to replace what it took to start up the engine. Also, realize that running the engine for a short time may increase moisture contamination in the fuel and oil. It is better to run the engine less often and run it longer, for perhaps an hour. The good news is this can be included in your battery recharge schedule.

Solar panels can greatly increase the time you can operate between battery charges.

Remember that different motorhomes have different equipment and that everyone has different habits and expectations. The above general guidelines should provide a useful starting point for building your own schedule and regimen for extended stays where power and water are not available. You too can become less dependent on hook-ups.

- Make sure to turn all appliances on propane.
- Purchase extra solar panels, if desired.
- Understand the inverter operations.
- One continuous duty solenoid is a .7 Amp draw, two solenoids will be a 1.4 Amp draw.
- A 13" TV has a 1.7 Amp draw.
- Rope lights (10 ft) are a 1.3 Amp draw.
- The porch light is a 2.0 Amp draw.
- One fluorescent dual bulb light is a 0.9 Amp draw.

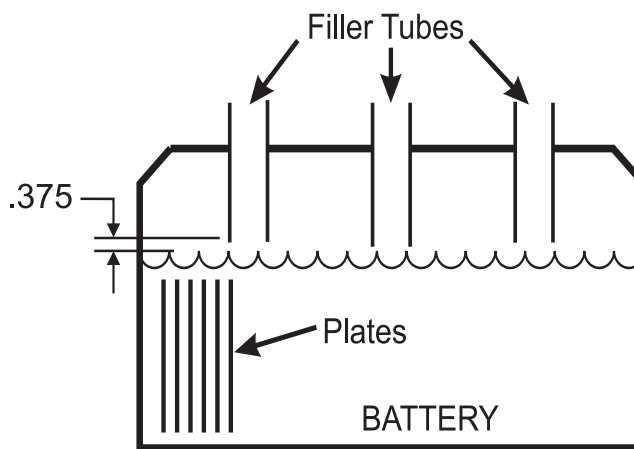

Battery State of Charge	Spec. Gravity	Voltage
100%	1.265	12.7
75%	1.225	12.4
50%	1.190	12.2
25%	1.155	12.0
Discharged	1.120	11.9 or Less

NOTE: The distilled water level in battery should be 3/8" below the filler tube.

*The distilled water level in battery should be 3/8" below the vent tube.*



## GFCI BREAKERS & OUTLETS

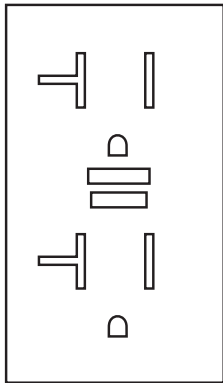

GFCI INTERRUPTER  
OUTLET

A ground fault circuit interrupter “GFCI” can be found in two different types of applications. One type is incorporated in a breaker used in 120 Volt AC breaker panels, the other is incorporated in an outlet. The GFCI, whether it is a breaker or an outlet, offers two types of protection. One type of protection is from over-current or shorts. It also provides protection for persons against hazardous ground fault currents which can result in injury or death. Ground fault currents are currents that flow from the “HOT” or power terminal through a person to the ground. For example, touching a faulty appliance while standing on or making contact with an electrical ground such as a water fixture, bathtub or the earth. If the device has been properly installed it will offer protection against the type of shock that can result from faulty insulation, wet wiring from inside an appliance or any device or equipment plugged in or wired to that circuit. The “ground fault” portion of the outlet or breaker uses sensitive electronics inside the outlet or breaker to detect a ground fault problem. The electronics monitor the normal current of power, flowing to the “hot” or black wire through the load (eg. a light bulb or appliance) and coming back on the “neutral” or white wire. If just a small amount of the current comes back on the safety ground wire the electronics will “trip” the breaker or outlet stopping the flow of electricity. The amount of current it takes to trip the device from a ground fault varies slightly from the different outlet or breaker manufacturers (approximately 30 mils or less). Electrical shocks resulting from ground faults can be felt, but such a shock is considerably less than one without ground fault protection. People with heart conditions or other conditions that make them susceptible to shocks can still be seriously injured. A GFCI outlet or breaker will not protect against shock from a normal current flow. For example, a shock from touching both metal prongs of an electrical cord or appliance while plugging it in.



**WARNING: If a breaker or outlet trips continually DO NOT continue to reset breaker or outlet until the problem has been identified and corrected.**



**NOTE: The ground fault outlet or breaker should be tested once a month to insure it is working properly. Use the “TEST” button on the outlet or breaker. It should trip with an audible “click.” The breaker or outlet will not trip if no AC power is present to the device. If power is present and the device will not “trip,” replace it before using that circuit.**



**NOTE: One mil is 1/1000 of one amp.**

Statistics show that most fire casualties are not caused by direct flame, but by less visible smoke (products of combustion). The smoke detector responds to both visible and invisible products of combustion. The smoke detector will automatically return from alarm to normal state when the reason for activation, the presence of smoke, is completely removed. Common causes of fires are smoking in bed, leaving children unattended and cleaning with flammable fluids. Please be safety conscious and avoid unnecessary risk.

## SMOKE DETECTOR



**WARNING: There is no way to insure there will be no injury or loss of life in a fire; however, the smoke detector is intended to help reduce the risk of tragedy. Additional smoke detectors may help to reduce the risk. Proper use and care of the smoke detector could save lives.**

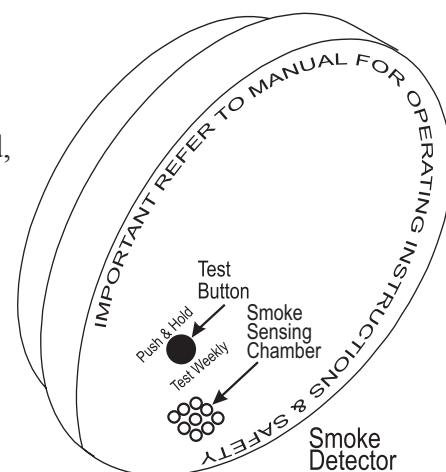

To test the electronics of the alarm press the test button on the cover of the smoke alarm for a few seconds. The smoke alarm will sound by making a continuous loud beep. To complete the test sequence release the button and the alarm should stop.

### How to Test



**NOTE: Test the smoke alarm operation after the motorhome has been in storage, before each trip and at least once a week during use.**

Vacuum the slots in the cover and sides with a soft brush attachment every month. Your smoke alarm should be cleaned every six months to help keep the unit working efficiently.

### Maintenance

The battery should power the smoke alarm for at least one year under normal use. When the battery reaches the end of its normal life a low battery warning (intermittent beeping) will indicate the need for battery replacement. Some owners may find it practical to replace the battery during the time changes in the spring and fall.

If the alarm does not sound when the test button is pushed, or with a smoke test, try the following:

### Troubleshooting

- Inspect for obvious damage.
- Check for the recommended battery type.
- Check the battery for proper connection, or replace the battery if needed.
- Gently vacuum as recommended.

If these procedures do not correct the problem, do not attempt repairs. If the smoke alarm is within the warranty period and the terms indicate the nature of the problem, return the unit to your dealer. Smoke detectors beyond warranty cannot be economically repaired.

Abnormal air conditions may cause the highly sensitive smoke alarm to give a false alarm. If no fire is apparent ventilate the room and/or blow fresh air into the motorhome until the alarm stops. Once cleared, the smoke alarm will automatically reset. Dust can lead to excessive sensitivity. Vacuum as needed.

## LP-GAS DETECTOR



LP Detector

Provided for safety is a LP Gas detector. This gas detector will detect both LP Gas and Methane Gas. Liquefied Petroleum (LP) Gas is heavier than air, Methane Gas is lighter than air. LP Gas will settle to the lowest point, generally the floor of the motorhome. Methane Gas will rise. The gas detector is also sensitive to other fumes such as hair spray, of which most contain butane as the propellant. Butane, like propane is heavier than air and will settle to the floor level where it will be detected. When this occurs, press reset button to stop alert sound for 60 seconds.

The other combustibles which will be detected include alcohol, liquor, deodorants, colognes, perfumes, wine, adhesives, lacquer, kerosene, gasoline, glues, most of all cleaning agents and propellant of aerosol cans. Most are lighter than air in their vapor state and will only be detected when the motorhome is closed up.

## Operation

Upon first application of power the LED will flash yellow for 3 minutes while the detector is stabilizing. At the end of the start cycle the LED will turn Green, indicating full operation. If the detector senses unsafe levels of gas it will immediately sound an alarm.

The gas detector operates on 12 Volts, with a current draw less than 1/10th of one amp.



**CAUTION: This detector will not alarm during the 3 minute warm up cycle.**

## Testing

Depress the TEST switch any time during the warm up cycle or while in normal operation. The LED should flash RED and the alarm should sound. Release the switch. This is the only way you should test your detector. The test feature checks full operation of the detector.



**WARNING: Test the operation of this detector after the motorhome has been in storage, before each trip and at least once per week during use.**

The Red LED will flash and the alarm will sound whenever a dangerous level of propane or methane gas is detected. The detector will continue to alarm until the gas clears or the Mute switch is pressed.

**Procedures To Take During An Alarm:**

1. Turn off all gas appliances, (stove, heaters, furnace), extinguish all flames and smoking material. Evacuate, leave doors and windows open.
2. Turn off the propane tank valve.
3. Determine and repair the source of the leak. Seek professional help if necessary.



**CAUTION: Do Not re-enter until the problem is corrected.**

**Alarm Mute:**

Press the Test-Mute button when the detector is in alarm.

1. The Red LED will continue to flash and the alarm will beep every 30 seconds until the gas level has dropped to a safe level.
2. The LED will flash Green until the end of the Mute cycle.
3. If dangerous gas levels return before the end of the mute cycle the alarm will beep 4 times and return to phase 1.
4. After 2 minutes the detector will return to normal operation (solid Green) or resound the alarm if dangerous levels of gas remain in the area.

**Fault Alarm:**

Should the microprocessor sense a fault in the gas detector a fault alarm will sound twice every 15 seconds. The LED will alternately flash Red to Green and the MUTE switch will not respond to any command. The gas detector must be repaired or replaced.

1. Vacuum the dust off the detector cover weekly (more frequently in dusty locations) using the soft brush attachment of your vacuum.
2. Do not spray cleaning agents or waxes directly onto the front panel. This action may damage the sensor, cause an alarm or cause a detector malfunction.

**Care**

## CARBON MONOXIDE DETECTOR

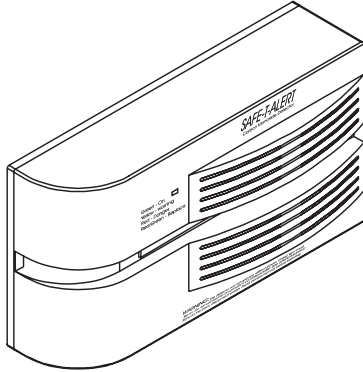

Carbon monoxide detector - located in bedroom curbside, underneath night stand cabinet, secured to outside wall.

The motorhome is equipped with a carbon monoxide detector. Carbon monoxide (CO) is a colorless, odorless and tasteless gas. Even low levels of CO have been known to cause brain and other vital organ damage in unborn infants, with no effect on the mother. In cases of mild exposure the symptoms may include: a slight headache, nausea, vomiting and fatigue. Symptoms for medium exposure may include a severe throbbing headache, drowsiness, confusion and fast heart rate. Extreme exposure can result in unconsciousness, convulsions, cardio-respiratory failure and death. Young children and household pets may be the first effected. The CO detector is designed to

detect the toxic CO fumes that result from vehicle exhaust and incomplete combustion sources like a furnace, gas stove or water heater. Consequently, it is uncommon for household smoke from cigarettes or normal cooking to cause the alarm to sound.



**NOTE: Activation of this device indicates the presence of carbon monoxide (CO) which can be fatal. A concentration of above 100 PPM will cause a warning condition. Individuals with medical problems may consider using detection devices with lower carbon monoxide alarming capabilities. Prolonged exposure to the horn at a close distance may be harmful to your hearing.**

### Operating Instructions

The detector is equipped with a self-cleaning CO sensor and requires a ten minute initial warm-up period to clean the sensor element and achieve stabilization. The green power light should be lit when the power is on. If the light is not lit turn off the power and check all wire connections. If the power is on and the connections are correct but the indicator still does not light, the detector should be returned for service. Do not attempt to fix the detector yourself. The indicator light displays a specific color to monitor the conditions as follows:

- **Green** - indicates an “ON” or normal condition. The CO detector has power and is sensing air for the presence of CO gas. The alarm horn will not sound.
- **Yellow** - indicates a “trouble” or malfunction condition. The alarm horn will sound and cannot be reset by the TEST/RESET button.

The CO detector is not working properly and must be immediately replaced or repaired.

- **Red** - indicates an “**alarm condition.**” The detector has sensed the presence of a hazardous level of carbon monoxide. The alarm horn will sound continuously until reset by the RESET switch.

---

When the alarm sounds you should have the detector and the motorhome checked by an authorized service technician as soon as possible. Never disconnect a CO detector to silence an annoying alarm. Evacuate the motorhome immediately when the RED light is lit and the alarm sounds. Do a head count to check that all persons are accounted for. Call the nearest fire department and ask them to determine the source of the carbon monoxide. Do not re-enter the motorhome until it has been aired out and the problem corrected.

### ***Alarm***

---

Test the carbon monoxide detector operation after the motorhome has been in storage, before each trip and at least once a week during use. You can test the alarm by holding the test button in until the alarm sounds. The alarm will stop beeping in about 30 seconds.

### ***Testing***

---

Use a vacuum cleaner to remove dust or any other buildup on the detector. Do not wash. Wipe the detector with a damp cloth and dry it with a towel. Do not open the detector for cleaning. Do not paint the detector. It is recommended that the carbon monoxide detector should be replaced every 10 years.

### ***Cleaning***

## FIRE EXTINGUISHER

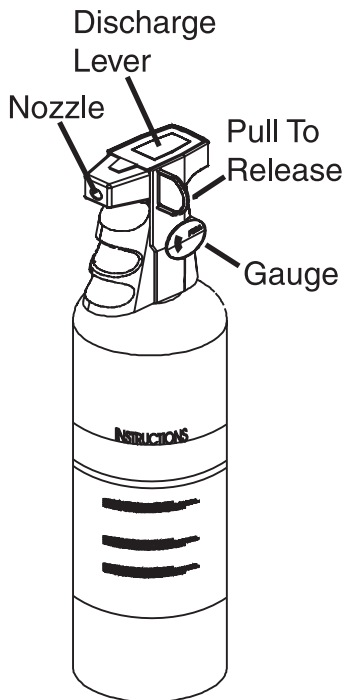

The fire extinguisher in the motorhome is located near the main entrance door. Please read the operating instructions that are printed on the fire extinguisher. If there is any doubt on how to operate the fire extinguisher, you and your family should practice using it. Be sure to replace or recharge the extinguisher immediately after use.

Inspect the fire extinguisher at least once a month. Do so more frequently if the extinguisher is exposed to weather or possible tampering. Do not test the extinguisher by partially discharging, this will cause a loss of pressure.

### Use the **PASS** word!

**P**ull the pin to unlock the extinguisher.

**A**im at the base (bottom) of the fire and stand 6-10 feet away.

**S**queeze the lever to discharge the agent.

**S**weep the spray from left to right until totally extinguished.

## EGRESS EXIT WINDOW

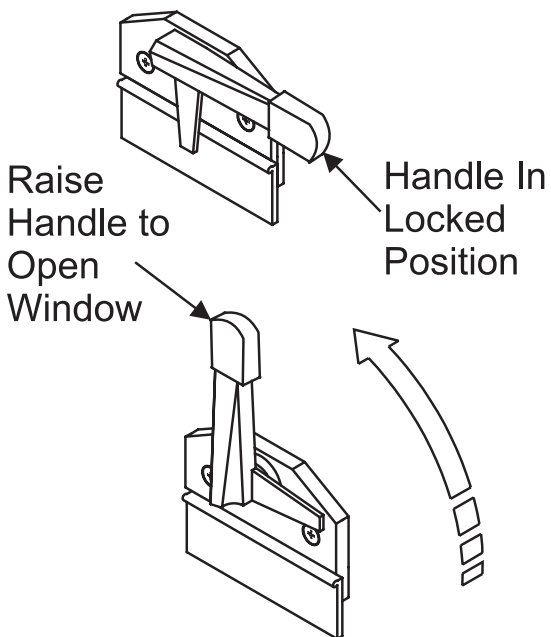

Egress Window Handle

An egress window is designated for use as an exit in the case of an emergency. Inside the motorhome the egress window is easily identified by the red locking handle. It is also marked as an "EXIT." Outside of the motorhome the egress window is identified by hinges along the top of the window. The glass slider in the egress window operates the same as all other windows. To open the egress window lift the red handle and push outward on the window. Pull the window closed and lower the handles to lock the egress window.

The egress window should be opened twice a year to ensure proper operation. The rubber seal tends to stick to the egress window.



## TIRES & WHEELS

The tire designed for your RV is a very technical and precisely engineered product. To obtain the maximum use and best service out of your tires it is helpful to understand the function of a tire. A tire is a “container” that holds air. It is the combination of air and tire that supports the motorhome and its contents. In addition, since the tire is the only contact that the motorhome has with the road surface it must provide other functions such as traction for moving, stopping, steering and providing a cushion for the motorhome.

The most important factor in maximizing the life of your tires is maintaining proper inflation. Driving on any tire that does not have the correct inflation pressure for the load of the motorhome is dangerous and may cause premature wear, tire damage and/or loss of control of the motorhome.

A tire that is underinflated will build up excessive heat that may go beyond the prescribed limits of endurance of the rubber and radial cords. This could result in sudden failure. A tire that is underinflated will also cause poor motorhome handling, rapid and/or irregular tire wear and an increase in rolling resistance which results in a decrease in its fuel economy.

Over-inflation will reduce the tire’s footprint or contact patch with the road reducing the traction, braking capacity and handling of the motorhome. A tire that is over-inflated for the load will also contribute to a harsh ride, uneven tire wear and will be more susceptible to impact damage.

Maintaining correct tire inflation pressure for each loaded wheel position on your motorhome is of the utmost importance and must be a part of regular motorhome maintenance.

### ***The Importance of Air Pressure***

Federal law requires that the tire’s maximum load rating be molded into the sidewall of the tire. If you look on your tire’s sidewall you’ll see the maximum load allowed for the size tire and load rating and the minimum cold air inflation pressure needed to carry that stated maximum load.

Utilizing less air pressure means a lesser load can be carried by the tire. The chart at the end of the section shows weights that can be supported by various air pressures.

The amount of air pressure you need to use is dependent on the weight of your fully loaded motorhome.

### ***How Much Air Should I Carry in My Tires?***

The GVWR (Gross Vehicle Weight Rating) and GAWR (Gross Axle Weight Rating) stickers on your RV (normally located on the support pillar next to the driver’s seat) will show you the chassis manufacturer’s and/or the RV manufacturer’s total vehicle maximum weight ratings and per axle weight rating.

### ***How to Determine the RV’s Correct Weight***



The GVWR is the maximum total weight for which the motorhome is rated—including passengers, fluids and cargo. The GAWR is the maximum for which a single axle is designed. These per axle and total maximum weight ratings could be limited by the tires, wheels, axle and axle bearings, the motorhome frame or other components of the motorhome.

The GAWR sticker is only a guide in knowing your maximum loaded axle weights and subsequently your correct tire inflation pressure. Every RV, even of the same make and model, will vary in actual loaded axle weights because of different options and personal loads.

While your actual loaded axle weight should be below the GAWR you must weigh your RV in a loaded condition to know its actual weight. Weigh the front axle, the total unit and the rear axle. It is possible for a motorhome to be within the GVWR yet overloaded on an axle. It is even possible for one wheel position to be overloaded, even though the GAWR has not been exceeded. For this reason (if there is room to the sides of the scales) weigh each wheel position of the motorhome. This will give you a clear indication of exactly how the weight of your RV is distributed. The Tire Industry Safety Council provides instructions on how to weigh your motorhome by wheel position. These instructions and diagrams are presented on the following pages. Once you know the total weight, and the weight on each axle, the tire load data chart in this manual will show you the correct cold inflation pressure per tire for each axle.

---

### ***Where to Weigh the Motorhome***

There are certified public scales. You will find public-access scales in a variety of places such as moving and storage lots, farm suppliers with grain elevators, gravel pits, recycling companies and large commercial truck stops.

If you are not aware of a nearby public scale check your area telephone book yellow pages under the “scales-public” section or “weighers.” A nominal fee will be charged, but this is money wisely spent.

---

### ***How to Weigh the Motorhome***

Your RV must be weighed fully loaded. Fully loaded means: passengers, food, clothing, fuel, water, propane, supplies, etc. Any towed vehicle (car/pick-up, boat or trailer) or item loaded on brackets on the back of the RV, such as bikes or motorcycles, should also be included in the weighing.

## **Tires - Inspecting**

What if you don't check your air pressure? If a tire picks up a nail or screw that creates a slow leak and causes some air pressure loss you might eventually spot this visually, if it is a front tire or an outside rear dual. However, if it is an inside dual the chances of spotting it without an air pressure check are very slim. If you begin driving while unaware of the low pressure tire, very quickly (in most cases a few miles) your outside rear tire, next to the low air pressure tire, is going to heat up carrying double its load which will cause both tires to fail. Then you have two tires down on the same side and on the same axle.

As you "preflight" check your motorhome every drive morning include an air pressure check of your tires. The peace of mind is worth the extra few minutes!

### **Proper Cleaning:**

Like the rest of your RV, it pays to keep your tires clean. Road oil will cause deterioration of the rubber. Dirt buildup will help hold chemicals in the air next to the tire and will also deteriorate the tire.

As with the cleaning of any rubber product, proper care and methods in cleaning must be used to obtain the maximum service years out of your tires. A soft brush and the normal mild soap that you would use to clean your RV may be used. If you use a dressing product to "protect" your tires from aging use extra care and caution. Tire dressings that contain petroleum products or alcohol may cause deterioration or cracking.

In many cases it is not the dressing itself that causes a problem but the chemical reaction which occurs. When these same dressing products are used on a passenger car tire that is replaced every three to four years it is rare to see a major problem. However, in most cases RV tires may last much longer due to limited annual mileage and the chemical reactions have much longer to take effect.

---

Extreme caution must be taken to ensure that the tires are fully supported when using blocks to level motorhome. The load on the tire should be evenly distributed on the block. In the case of duals distribute evenly on blocks for both tires. If not properly blocked the steel cables in the sidewall of the tires may be damaged and could lead to premature fatigue of the sidewall.

## **Blocking - When Leveling**

---

Your RV is designed for recreation, not long-term storage. However, unless you are a "full timer," you have no other choice. Rubber tires age faster when not being used. A cool, dry, sealed garage is your best bet for storage. Many RV's are stored outside in the elements. Some storage surfaces may cause tires to age prematurely. For this reason Goodyear recommends placing a barrier (i.e. cardboard, plastic or plywood) between the tire and the storage floor/ground surface.

## **Tire - Long Term Storage**

There are a few steps that you can take to reduce the aging effects from long-term storage or a non-use period. Thoroughly clean your tires. Cover the tires to block direct sunlight and ultraviolet rays. Store your RV out of a high ozone area. Failure to take these steps can cause early deterioration and shorten the life of your tires.



**NOTE: When the motorhome is stored the tires should be inflated to maximum inflation pressure as indicated on the sidewall of the tire.**

Before removing your motorhome from long-term storage thoroughly inspect each of its tires. This means a close examination of each tire's tread area and air pressure. If your pressure check indicates the tires have lost air during storage, be sure to inflate them to the correct pressure for the current load before putting the unit into service.

---

### **Care & Maintenance of Aluminum Wheels (Optional)**

- Clean frequently with high pressure water from a hose. The use of mild detergent will speed the cleaning process. Use no harsh alkaline, alcohol or acid cleaners. Secondary hand washing with a soft cloth may be required to remove some stubborn road films.
- When the tires are removed the entire wheel must be cleaned and inspected. With a wire brush or sandpaper remove dirt, corrosion or any foreign materials from the tire side of the rim. Do not use a wire brush to remove dirt and corrosion for the appearance surface of the wheel.
- To maintain the original appearance of your aluminum wheels the following procedures are recommended:
  1. After installing new wheels (prior to operating your motorhome) use a sponge, cloth or soft fiber brush to wash the exposed wheel surfaces with a mild detergent / warm water solution.
  2. Rinse thoroughly with clean water.
  3. Wipe dry to avoid water spots.
  4. Use a high quality, non-abrasive polish to remove stubborn road tars, insects or hard to remove deposits.
  5. To protect the appearance surface on Accu-Forge wheels, wax the cleaned surface with a high quality car wax.
  6. Clean your aluminum wheels as frequently as required to maintain their appearance.

## Tire- In Case of Flat Tire

If you have a flat tire it is recommended you call for roadside service. Because of the size and weight of the motorhome and its tires, proper equipment to change the tire is required. A professional service technician will have the proper equipment and training to repair or replace your tire. In the case of sudden tire failure avoid heavy braking. Hold the steering wheel firmly and gradually decrease speed. Slowly move to a safe off-road place, which should be a firm level spot. Turn your ignition OFF and turn your hazard flasher system ON. Goodyear has an emergency number which offers 24 hours assistance. To contact call (877) 484-7376. The old tire should be saved for warranty.

### Front Wheels:

Slide the front wheel over the studs, being careful not to damage stud threads. Snug the nuts in sequence. Do not tighten them fully until all have been seated. Tighten the nuts to the 500 ft.lbs sequence as shown in the illustration.

### Dual Rear Wheels:

Slide the inner dual wheel over the studs being careful not to damage the stud threads. Align the handholds for valve access and slide the outer dual wheel over the studs, again being careful not to damage the stud threads.

Snug the nuts in sequence. Do not tighten them fully until all have been seated. Tighten the nuts to 500 ft. lbs. using the sequence as shown in the illustration. The hub mount wheels use two piece flange cap nuts for both front and rear applications. No inner cap nuts are required.

### Torque the Nuts Properly:

- Be sure to tighten the wheel nuts to the recommended nut torque. Do not over tighten.
- Maintain the nut torque at the recommended level through planned periodic checks or at 10,000 miles intervals, whichever comes first.
- If air wrenches are used they must be periodically calibrated for the proper torque output. Use a torque wrench to check the air wrench output and adjust the line pressure for the correct torque.

**For Used Nuts, Add 2 Drops of Oil  
Between Flange and Hex**

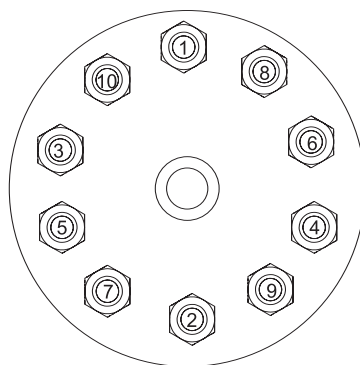

**Nut Tightening Sequence**

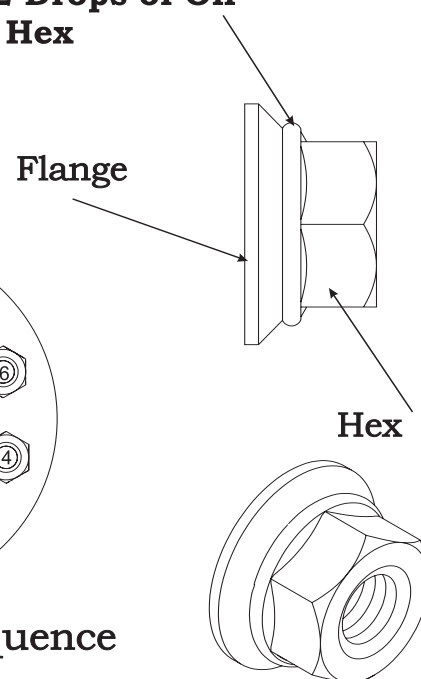

## **INFLATION & WEIGHING**

To accurately determine the proper inflation pressure the motorhome should be weighed after it has been fully loaded. First, position the front wheels on the scale and take a weight reading. Divide this reading by 2 to determine the load carried by each tire/wheel. Next, position the rear drive wheels on the scale and take the weight reading. Divide this reading by 4 to determine the load carried by each tire/wheel to determine the proper tire pressure.

---

### ***When to Check the RV's Tire Pressure***

Now that you have found what the correct air pressure per axle needs to be for your RV, you need to know when to check your air pressure. You should check the air pressure every two weeks or at least once a month and before any major trip. Your RV tire air pressure should be checked every "drive" morning on long trips. On short trips, driving a day or less, your tires should be checked before you leave on your trip and again before you start your trip home. If your motorhome is stored for any length of time the air pressure should be checked prior to storage, but more importantly, when it is pulled out of storage.

Check your tires when they are "cold" and have not been driven for more than one mile. The stated load capacity for a given cold inflation pressure is based on ambient outside temperature. If you must check your tires when they are warm or hot do allow for a slight increase in air pressure and make sure they are within a couple of pounds of each other on the same axle. Never let air out of a hot tire.

To maintain the inflation pressure in your tires you will need the proper equipment. It is recommended you purchase a quality truck tire air gauge which has an angle dual head. This type of gauge allows you to check inflation on the inner dual wheel which has the valve stem pointing toward you, and on the outer wheel which has the valve stem pointing away from you. Nothing should restrict your ability to check your tire's air pressure daily when you are driving your RV. Pressure sealing valve caps should always be used to prevent air from escaping from the valve stem. If you use valve stem extension hoses make sure they are good quality stainless steel braid reinforced and are securely anchored to the outer wheel. If your RV has a wheel cover which must be removed to check the inflation consider removing them as the extra time and effort required may lead you to avoid checking your air pressure.

Optimum tire performance is achieved with proper inflation pressures for the loads being carried. The air pressure of all tires should be checked and corrected prior to travel, or daily if in full time use. An accurate tire gauge should be used to check the cold tire pressure. Cold tire pressure can be defined as a tire that has been dormant for three or more hours, or a tire that has been driven less than one mile.

Proper inflation pressure should be determined after the motorhome has

been fully loaded and weighed. Divide the steer axle weight by 2 when determining the load carried by each of the front tires. The drive axle weight is divided by 4 when determining the load carried.

Tires of different patterns should not be mixed on the same axle. The difference in tractive force could cause rear end gear fight and mechanical damage to the drive train. Tires of different size or construction must never be mixed on the same axle.

**Higher than recommended pressure can cause:**

- Hard ride
- Tire bruising or carcass damage
- Rapid tread wear at center of tire

**Lower than recommended pressure can cause:**

- Tire squeal on turns
- Rapid and uneven wear on the edges of the tread
- Tire rim bruises and rupture
- Tire cord breakage
- High tire temperatures
- Reduced handling
- High fuel consumption

**Unequal tire pressures on same axle can cause:**

- Uneven braking, swerve of acceleration
- Steering lead, torque steer
- Reduced handling

---

The useful tire life of your tire is achieved by the uniform wear for all tires. This can be increased with tire rotation. The first tire rotation is the most important. The tire rotation pattern used for your motorhome should be evaluated by your Goodyear Tire Center. Any unusual or unique wear pattern which may have developed should be evaluated before rotation. Misalignment, imbalance or other mechanical problems may exist and will need corrected prior to rotation.

The tire rotation should be performed every 6,000 to 8,000 miles, or at any sign of uneven wear. After a tire rotation, the inflation pressures should be checked and adjusted for the actual loads of the wheel position accordingly.

Tires are covered by Goodyear warranty: Monaco Coach Corporation is not responsible for tire wear.

## ***Tire Rotation***

## **Weight Terms**

The GVWR (Gross Vehicle Weight Rating) and GAWR (Gross Axle Weight Rating) stickers on the motorhome (normally located on the support pillar next to the driver's seat) will show the chassis manufacturer's and/or the RV manufacturer's total vehicle maximum weight ratings and per axle weight rating.

The GVWR is the maximum total weight for which the motorhome is rated—including passengers, fluids and cargo. The GAWR is the maximum for which a single axle is designed. These per axle and total maximum weight ratings could be limited by the tires, wheels, axle and axle bearings, the motorhome frame or other components of the motorhome.

The GAWR sticker is only a guide in knowing the maximum loaded axle weights and subsequently the correct tire inflation pressure. Every RV, even of the same make and model, will vary in actual loaded axle weights because of different options and personal loads.

While the actual loaded axle weight should be below the GAWR, you must weigh your motorhome in a loaded condition to know its actual weight. Weigh the front axle, the total unit and the rear axle. It is possible for a motorhome to be within the GVWR yet overloaded on an axle. It is even possible for one wheel position to be overloaded, even though the GAWR has not been exceeded. For this reason (if there is room to the sides of the scales) weigh each wheel position of the motorhome. This will give a clear indication of exactly how the weight of the motorhome is distributed. These instructions and diagrams are presented on the following pages. When the total weight, and the weight on each axle, is known the tire load data chart in this manual will show you the correct cold inflation pressure per tire for each axle.

There are two important factors to consider when loading the motorhome: total weight and balance. When loading heavy objects keep them as low as possible, preferably on the floor. Load weight must be distributed as evenly as possible. The following is an explanation of commonly used weight abbreviations.



MODEL YEAR: 2001 MAKE: MONACO COACH MODEL: DIPLOMAT

UNIT NO. \_\_\_\_\_ CHASSIS VIN: \_\_\_\_\_

- |  | <u>LBS.</u> | <u>KGS.</u> |
|--|-------------|-------------|
| <b><u>GVWR</u></b> (Gross Vehicle Weight Rating) is the maximum permissible weight of this fully loaded motorhome .....  |             |             |
| <b><u>UVW</u></b> (Unloaded Vehicle Weight) is the weight of an exemplar Motorhome as manufactured at the factory with full fuel, engine oil and coolants (*1) .....                   |             |             |
| <b><u>SCWR</u></b> (Sleeping Capacity Weight Rating) is the manufacturer's designated number of sleeping positions multiplied by 154 pounds (70 kilograms) .....                       |             |             |
| <b><u>CCC</u></b> (Cargo Carrying Capacity) is the GVWR minus each of the following: UVW, full fresh (potable) water weight (including water heater), full LP-Gas weight and SCWR..... |             |             |
| <b><u>GCWR</u></b> (Gross Combination Weight Rating) is the maximum allowable combined weight of this motorhome and any towed vehicle (*2).  |             |             |

**CARGO CARRYING CAPACITY (CCC) COMPUTATION**

GVWR .....	_____	_____
minus UVW .....	_____	_____
minus fresh water (*3) weight of gallons @ 8.3 lbs./gal .....	_____	_____
minus LP-Gas weight of gallons @ 4.5 lbs./gal .....	_____	_____
CCC for this motorhome (*4) .....	_____	_____

**CONSULT OWNER MANUAL(S) FOR SPECIFIC WEIGHING INSTRUCTIONS AND TOWING GUIDELINES.**

Factory installed options do not include dealer installed after market equipment.

**WARNING:DO NOT EXCEED THE GVWR, GCWR AND/OR GAWR AFTER LOADING YOUR MOTORHOME WITH WATER, FUEL, PASSENGERS AND CARGO. GAWR (Gross Axle Weight Rating) means the maximum permissible load weight a specific axle is designed to carry. See Federal Certification Label for disclosure of The GAWR for each axle.**

- (\*1) The UVW has been determined by weighing an exemplar motorhome with some but not all optional equipment available for each model year, make and model of motorhome. The result of the weighing of the exemplar motorhome is then used in calculating the UVW of other motorhomes of same model year, make and model. Your actual UVW may vary based upon options ordered. Please contact the manufacturer of the actual weight of each option.
- (\*2) Consult your Owner's Manual for towing limitations, restrictions and other guidelines.
- (\*3) Your motorhome's fresh water tank and water heater taken together determine the gross fresh water capacity. Your usable fresh water capacity, however, may be less.
- (\*4) Dealer installed equipment and towed vehicle tongue weight will reduce CCC.



## WEIGHING THE MOTORHOME

Improperly inflated tires or suspension that is incorrectly loaded can result in poor fuel economy, poor handling and over-stressed chassis components. Vehicle loading affects tire inflation pressure and the load carried by each axle. Motorhome axle configuration and floor plan styles will require different weighing procedures.



**WARNING: Improperly inflated or overloaded tires can cause a blowout. An overloaded axle can cause a component failure of the suspension system. Tire blowouts or broken suspension components can lead to loss of vehicle control resulting in property damage, personal injury or death.**



**CAUTION: If actual weight carried by any tire is below the tire chart weight specification a minimum tire pressure of at least 75 psi. must be maintained. Tire pressure below 75 psi. can overheat and damage the tire casing leading to premature tire failure or blowout.**

### Slide Out Tire Pressure:

A motorhome equipped with slide out room(s) will weigh slightly heavier on the driver side. Tire inflation pressures between the driver side and passenger side will differ. More air pressure will be required in the driver side tires due to the added weight on that side.



**NOTE: When weighing a slide-out motorhome each tire must be weighed independently to obtain the correct weight carried by each tire.**

### Scales:

Certified public scales are located in a variety of places such as moving and storage lots, farm suppliers with grain elevators, gravel pits, recycling companies and large commercial truck stops.

If you are not aware of a nearby public scale check the local area telephone book yellow pages under “scales-public” section or “weighers.” A nominal fee will be charged, but this is money wisely spent.

Weight scale types and weighing methods will affect the procedure used to determine proper tire inflation pressure and axle loading. The size of some scales will allow the entire motorhome to fit on the scale, which will read the GVW with only one scale recording required. Other scales are designed to weigh only one axle at a time, which may require two or three scale readings to determine the GAW or GVW total. Some scales will read only one wheel position at a time due their physical size. Several scale readings may be required to determine the GAW or GVW total.

Slide-out equipped motorhomes will require each wheel position to be weighed. This is referred to as a four corner weigh. This type of weighing procedure will accurately determine what the correct tire inflation pressure should be. Depending on the type of scale being used, several different scale readings may be required.



**NOTE: The most accurate method to determine proper tire pressure is a four corner weigh. A slide-out motorhome will require each tire to be weighed independently. Weighing an axle will net the total weight carried by that axle. When calculating the drive axle dual tire pressure using a independent corner weigh method, divide the total weight by two to determine the weight carried by each tire. When weighing the entire drive axle, divide the total weight by four to determine the approximate weight carried by each tire.**

**Example:**

The motorhome must be weighed fully loaded to obtain accurate scale readings and to determine the proper tire pressure.

- Take the rear axle gross axle weight rating (GAWR) and divide it by two. Record the figure next to scale B  $GAWR \div 2$ . Example: If rear axle GAWR is 13,000 lbs.  $GAWR \div 2$  would be 6,500 lbs.
- Weigh the driver's side rear corner (scale B) and record the scale reading next to gross axle weight (GAW) for scale B. Example: Scale B reading is 5100 lbs.
- Repeat procedure for the rest of the scale readings.
- Add the GAWR from scales B and D and enter the sum next to the final GAWR. Example 13,000.
- Add the GAW from scales B and D and enter this sum next to the final GCAW. Example: 10,000.
- Compare scale readings GCAW against GAWR readings. All figures on line 2 are not to exceed figures on line 1.
- Use tire chart with scale reading to determine correct tire pressure.



**NOTE: Scale readings and gross axle weight ratings are fictitious. Actual scale readings and gross axle weight ratings will vary with model and options.**

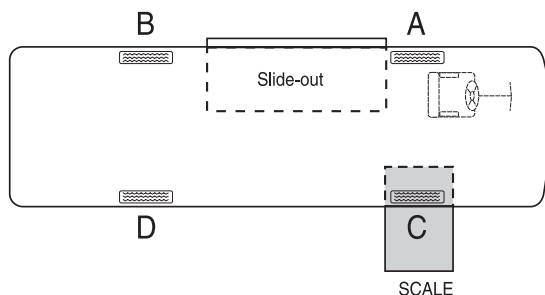

**Rear**

<b>Scale</b>	<u>1. <math>GAWR \div 2</math> (6,500)</u>				
<b>B</b>	<u>2. GAW (5100)</u>				
	+		=		
					<u>1. <math>GAWR</math> (13,000)</u>
					<u>2. GCAW (10,000)</u>
<b>Scale</b>	<u>1. <math>GAWR \div 2</math> (6,500)</u>				
<b>D</b>	<u>2. GAW (4,900)</u>				

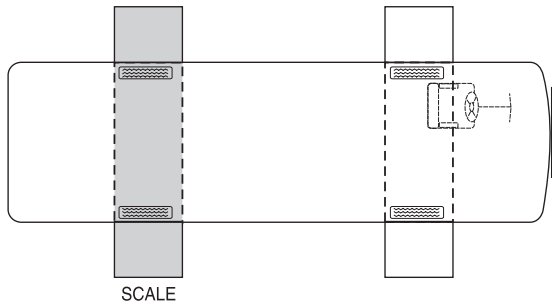

**Weighing a two axle non slide motorhome:**

- Record the gross axle weight ratings (GAWR) and the gross vehicle weight rating (GVWR).
- Weigh and record each wheel position or total axle weight.
- If necessary, adjust the payload so the GAWR is not exceeded. Total combined weights must not exceed the GVWR.
- Using the tire chart, locate the recommended air pressure for the weight carried by each tire. Adjust the tire pressure accordingly.

$$\begin{array}{rcl} \underline{\text{GAWR (Rear)}} & + & \underline{\text{GAWR (Front)}} & = & \underline{\text{GCVW}} \\ \underline{\text{GAW (Rear)}} & & \underline{\text{GAW (Front)}} & & \underline{\text{GCAW}} \end{array}$$

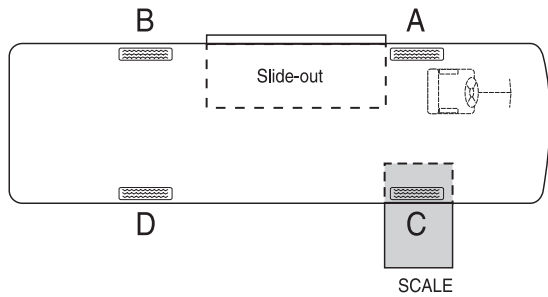

**Weighing a two axle slide out motorhome:**

- Slide rooms must be in the retracted position.
- Record the gross axle weight ratings (GAWR) and the gross vehicle weight rating (GVWR).
- Weigh and record the weight placed on each tire.
- If necessary, adjust the payload so the GAWR is not exceeded. Total combined weights must not exceed the GVWR.
- Using the tire chart, locate the recommended air pressure for the weight carried by each tire. Adjust the tire pressure accordingly.

	<b>Rear</b>	
<b>Scale</b>	$\underline{\text{GAWR} \div 2}$	
<b>B</b>	$\underline{\text{GAW}}$	
	+	=
		$\underline{\text{GAWR}}$
		$\underline{\text{GCAW}}$
<b>Scale</b>	$\underline{\text{GAWR} \div 2}$	
<b>D</b>	$\underline{\text{GAW}}$	

	<b>Front</b>	
<b>Scale</b>	$\underline{\text{GAWR} \div 2}$	
<b>A</b>	$\underline{\text{GAW}}$	
	+	=
		$\underline{\text{GAWR}}$
		$\underline{\text{GCAW}}$
<b>Scale</b>	$\underline{\text{GAWR} \div 2}$	
<b>C</b>	$\underline{\text{GAW}}$	

**Chart - Tire Inflation**

Use the tire chart to locate the recommended air pressure for the weight carried by each tire. A quality truck tire gauge with an angle dual head is recommended. Adjust the tire pressure accordingly.

TIRE SIZE	MAX Speed Rating (MPH)	Dual (D) Single (S)	INFLATION PRESSURE PSI												
			65	70	75	80	85	90	95	100	105	110	115	120	125
8R19.5	75	D	2350	2460	2570	2680	2780	2880	2980	3070	3160	3375(F)			
		S	2410	2540	2680	2800	2930	3060	3170	3280	3400	3500(F)			
225/70R19.5	75	D		2720	2860	3000	3115	3245	3415(F)						
		S		2895	3040	3195	3315	3450	3640(F)						
245/70R19.5	75	D		3415	3515	3655	3875(F)	3940	4075	4375(G)					
		S		3640	3740	3890	4080(F)	4190	4335	4545(G)					
265/70R19.5	75	D				3750	3930	4095	4300	4405	4560	4805	4860	5070(G)	
		S				3970	4180	4355	4540	4685	4850	5070	5170	5355(G)	
9R22.5	65	D	3120	3270	3410	3550	3690	3820	3950(F)						
		S	3190	3370	3560	3730	3890	4050	4210	4350	4500(F)				
10R22.5	65	D	3690	3870	4040	4200	4375	4520	4670	4875(F)	4970	5110	5250(G)		
		S	3770	4000	4210	4410	4610	4790	4970	5150(F)	5320	5490	5680(G)		
11R22.5	75	D				4760	4950	5120	5300	5470	5750(G)	5800(H)			
		S				4990	5220	5430	5640	5840	6175(G)	6240	6430	6610(H)	
12R22.5	65	D				5190	5390	5590	5780	5960	6150	6320	6500	6750(H)	
		S				5450	5690	5920	6140	6370	6590	6790	7010	7390(H)	
245/75R22.5	75	D		3260	3425	3640	3740	3890	4080	4190	4335	4410(G)			
		S		3470	3645	3860	3980	4140	4300	4455	4610	4675(G)			
255/70R22.5	75	D		3585	3765	3970	4110	4275	4410	4455	4610	4675	5070(H)		
		S		3815	4005	4190	4370	4550	4675	4895	5065	5205	5510(H)		
265/75R22.5	75	D			4040	4205	4370	4525	4685	4805(G)					
		S			4070	4255	4440	4620	4800	4975	5150	5205(G)			
275/80R22.5	75	D				4855	5080	5305	5525	5745	5965	6180	6395(H)		
		S				5265	5515	5755	6000	6235	6475	6710	6940(H)		
295/75R22.5	75	D			4690	4885	5070	5260	5440	5675(G)	5800	6005(H)			
		S			4725	4945	5155	5370	5510	5780	5980	6175(G)	6370	6610(H)	
295/80R22.5	75	D				4855	5100	5335	5570	5805	6035	6265	6490	6720	6940(H)
		S				5480	5750	6020	6285	6550	6810	7070	7320	7580	7830(H)
315/80R22.5	75	D				5840	6070	6395	6540	6770	6940	7210	7610(J)		
		S				6415	6670	6940	7190	7440	7610	7920	8270(J)		
285/75R24.5	75	D			4740	4930	5205	5310	5495	5675(G)					
		S			4770	4990	5210	5420	5675	5835	6040	6175(G)			

Monaco Coach Corporation is not the author of this chart and makes no representation or warranty concerning the accuracy of the information disclosed by the chart. Monaco is not responsible for the accuracy of the information disclosed or for any errors within the Tire Inflation Chart.

## IEWS -Front & Rear

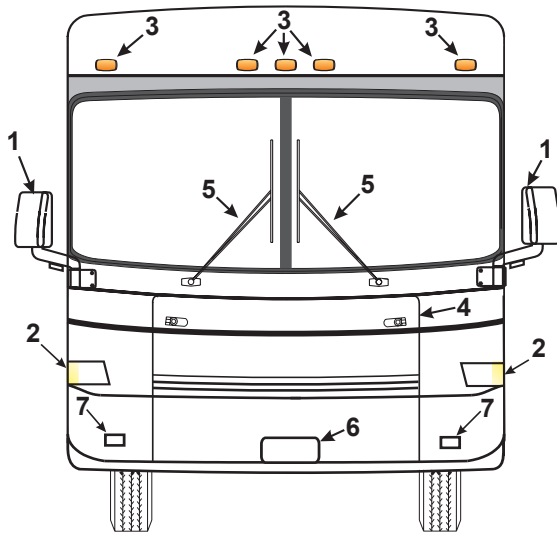

**Front**

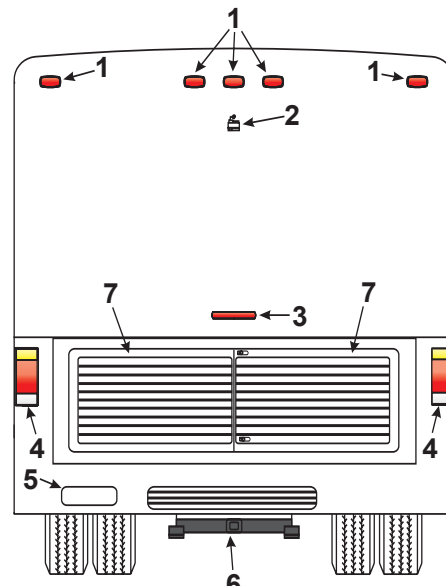

**Rear**

1. Mirrors
2. Headlights
3. Clearance Lights
4. Generator Compartment/Front Hood
5. Windshield Wipers
6. License Plate
7. Fog Lights

1. Clearance Lights
2. Rear View Camera
3. Third Brake Light
4. Tail Light
5. License Plate
6. Rear Tow Hitch
7. Engine Compartment

## IEWS Roadside

Locations vary from model to model. Identify each by their specific view.

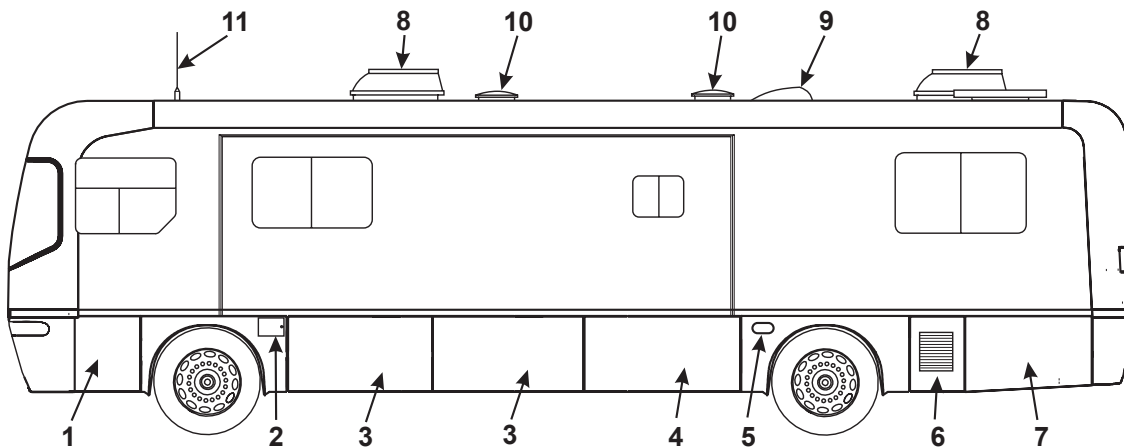

- |   |  |
|---|--|
| 1. Chassis Electrical Panel.                            | 7. Electric Cord (Shore Line), Engine Air Cleaner. |
| 2. Fuel Fill.   | 8. Roof Air Conditioner.                           |
| 3. Storage Compartment.                                 | 9. Shower Dome.                                    |
| 4. Water Control Panel.                                 | 10. Roof Vent.                                     |
| 5. Side Marker Lamp.                                    | 11. Radio Antenna.                                 |
| 6. Engine Diagnostic Compartment & Leveling Jacks Pump. |  |

## Curbside

Locations vary from model to model. Identify each by their specific view.

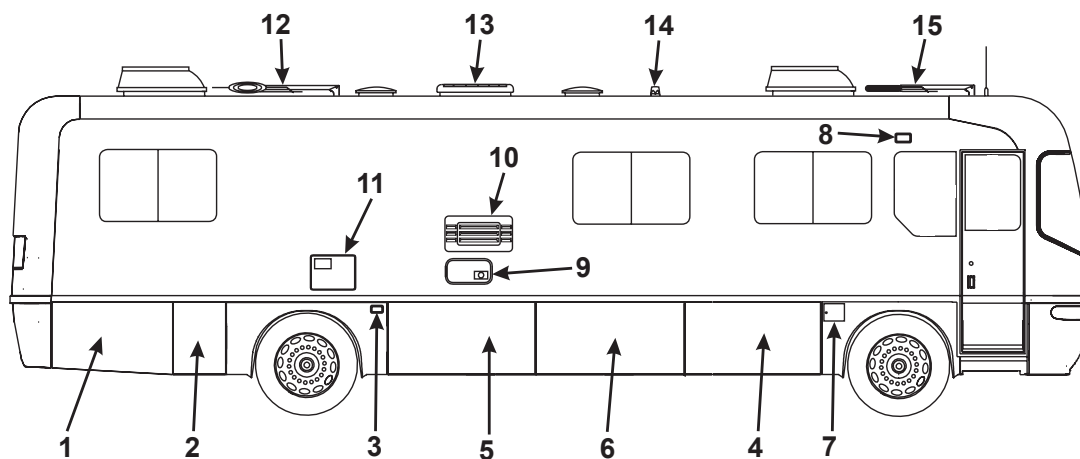

- |   |                               |
|---|-------------------------------|
| 1. Storage/Power Inverter.  | 7. Fuel Fill.                 |
| 2. Battery Disconnects/Batteries.   | 8. Porch Light                |
| 3. Side Marker Lamp.  | 9. Furnace Compartment.       |
| 4. Storage Compartment.   | 10. Refrigerator Compartment. |
| 5. LP Fill Compartment & LP On/Off Switch.  | 11. Water Heater Compartment. |
| 6. Storage Compartment; LP Manual Shut-Off Valves Access Door & Telephone/TV Cable Hookups. | 12. TV Antenna.               |
|   | 13. Refrigerator Vent.        |
|   | 14. Holding Tank Vent         |
|   | 15. Satellite Antenna.        |

---

**NOTES**



# Diplomat

## SECTION 3 CARE & MAINTENANCE

### **EXTERIOR CARE • 69**

*Corrosion • 69*

*Washing • 69*

*Drying • 70*

*Waxing • 70*

*Bright Metal • 71*

*Maintenance • 71*

*Seal Inspections • 72*

*Sealant Types • 72*

### **INTERIOR CARE • 73**

*Fabrics • 73*

*Fabric Specifications • 76*

*Vinyl • 78*

*Leather • 80*

*Floor - Carpet Cleaning • 81*

*Tile • 82*

*Ceiling • 83*

*Wall Coverings • 83*

*Countertops • 84*

*Windows • 85*

*Mini-Blinds • 86*

*Day/Night Shades • 86*





## EXTERIOR CARE

### Corrosion

The most common cause of corrosion to the motorhome is the accumulation of road salts, grime and dirt. These elements, combined with moisture, may possibly cause early component failure. Salt air and fog from coastal trips can greatly accelerate the corrosion process. Corrosive materials collected from roadways accumulate on the undercarriage, around wheel openings and on the radiator charge air cooler package. These areas need to be cleaned periodically to help prevent component failure due to corrosion. If the motorhome is driven in areas where road salts are used it should be washed at least once a week. Otherwise, it is recommended to hose off the undercarriage area at least once a month to help minimize the corrosion process. High pressure washers or steam cleaners are the most effective way of cleaning off the underside and inside wheel openings. **Avoid directly spraying the painted surface with a high pressured washer.** Remove road debris and mud that has accumulated. Material left behind can intensify the corrosion problem.



**CAUTION: Exercise caution when cleaning the radiator charge air cooler package. Damage to the fins can result when using a high pressure washer or steam cleaner. Nozzle discharge pressure can exceed 1,800 psi. Avoid using high pressure steam cleaners on the exterior paint surfaces. Remove all spattered washing debris from the exterior paint surfaces as soon as possible.**

The life of the exterior paint finish can be extended if properly cared for. Periodic cleaning will help preserve the paint finish. The motorhome is painted with a “base coat, clear coat system.” The clear coat is a polyurethane based material which brings out the shine or luster to the base coat paint. Care should be used when washing the motorhome. Use only mild detergents or preferred specifically designed automotive detergents. Avoid using abrasive cleansers or laundry detergents as they may scratch the clear coat or leave a soap film. The use of specially designed automotive washing utensils such as soft bristle brushes are acceptable, as long as they do not trap abrasive material and scratch the surface while being used. Before washing the motorhome remove most of the accumulated dirt and “road wash” behind wheel openings, below the windshield and on the rear of the motorhome. If the build up is excessive run water over a soft brush while gently scrubbing the surface in one direction. This will help float away the “build-up” from the clear coat. Avoid back and forth or circular motions as this may act like sandpaper, scratching the clear coat and leaving a haze or “swirl marks.” After removing the heavy build-up use the mixed detergent solution to wash the motorhome. Start washing at the top of the motorhome working towards the bottom. If possible, wash the motorhome in a shaded area when the exterior is not hot to the touch. If necessary, turn the motorhome around to keep the area being washed in the shade. Try not to allow the detergent to dry onto the clear coat surface. Use plenty of water when rinsing the surface to remove any detergent residue.

## Washing

## Drying

Drying chamois cloths come in natural and synthetic materials. Either type is acceptable as long as the surface is clean. Soak the chamois in clean water until all chamois material has absorbed water. Wring excess water from chamois. Start at the top and work towards the bottom. Use a downward “S” pattern to remove water from the surface and wring out the chamois as needed. Using a chamois cloth to remove the rinse water is not necessary, but the effort can be worthwhile.

---

## Waxing

To wax or not to wax? This is a good question. There are many schools of thought on this issue. The two most common thoughts are:

- The clear coat needs to “breathe.” A layer of wax will seal the clear coat not allowing it to breathe, possibly leading to failure of the clear coat.
- If the surface is not waxed, what is protecting the surface from the environment (road salts, acid rain, road tar, ultraviolet light)?

Monaco Coach Corporation recommends the use of wax twice a year: spring and fall. Many types of protective barriers are available today that may be applied to the clear coat: glazes, waxes, polishes, rubbing compounds or combinations of these products.



**NOTE: When selecting a product for use follow the product manufacturer’s recommended application instructions.**

### Types of Products:

**Glazes:** Glazes are generally used to fill very fine scratches in the clear coat, being applied either by hand or by using a polisher with a special pad.

**Waxes:** Waxes come in many types of chemical make-ups. The popular Carnuba wax is a natural occurring wax from the leaves or fronds of the Carnuba palm tree. Mineral waxes have a paraffin base. There are also other topical application products which contain silicone.

**Polishes:** Polishes usually contain a combination of wax based substances with an abrasive, getting the two for one idea. These products can be too abrasive for clear coats and are not recommended for use.

**Rubbing Compounds:** These types of products are generally applied by using a buffer. The use of rubbing compounds should be left to professionals as undesired results can occur quickly. These types of products are generally used to correct or flatten a surface by removing high spots or small amounts of material.

When selecting a product the container should be marked, “safe for clear coats” or “clear coat safe.” Carefully follow all manufacturer’s application instructions when using a product. Upon first use of a product try it on a “small test spot” in an

inconspicuous area in case an undesired reaction occurs. Observe the test area from different angles checking for hazing or swirl marks. If an abnormal reaction to the finish results, discontinue product use and consult the product's manufacturer. If the product is a paste, do not allow dried paste to be baked on by the sun. Remove paste shortly after drying. Clean, dry, 100% cotton cloths or cotton baby diapers are best suited for the removal of dried paste. Turn the cloth often. Use a separate clean cloth to buff. The surface should feel "slick" when rubbing cloth lightly over it. Avoid repeated wax applications which can cause wax to build up. Some very fine scratches or swirl marks may be removed by an application of a glaze. These types of glazes fill the scratches or swirl marks.

The motorhome has a large surface area. Washing and waxing may not be completed in one afternoon. Select sections to wax until the motorhome is complete. If the task seems formidable have an automotive detailer perform the task.

All chrome, stainless steel and aluminum should be washed and cleaned each time the motorhome is washed. Use only automotive approved non-abrasive cleaners and polishes on exterior bright work. Aluminum wheels should be cleaned regularly with a non-abrasive cleaner recommended for aluminum wheel care. Do not use rubbing compounds.

---

### **Bright Metal**



**NOTE: When using chemicals to remove road tars, use only automotive type products that are recommended for use on painted surfaces and fiberglass. Observe the warning recommendations and directions printed on the container of any agent being used.**

The motorhome is subjected to a variety of outside conditions. While the coach is parked it is exposed to humidity, ultraviolet rays, acid rain and other organic environmental conditions. While in operation the coach is subjected to twisting and flexing caused by going in and out of driveways, bouncing through potholes and winding over mountain roads.

Periodic inspection of the fiberglass exterior may reveal minute cracks in the surface commonly called "spider cracks" or "hairline cracks," which are caused by the flexing of the fiberglass exterior. These are quite normal. If a crack represents a threat to the integrity of the fiberglass it will open up and the weave of the cloth would be visible. If the exterior has been damaged, prevent moisture penetration, especially in freezing climates. Cover the area as quickly as possible. Use plastic sheeting and tape, if necessary, so that moisture will not get into the motorhome and damage the interior.

---

### **Maintenance - Exterior**

## Seal Inspections

Periodic resealing of the joints and seams is necessary to prevent the entrance of moisture into the motorhome. Enough emphasis cannot be placed on this issue. Extreme damage from a water leak can occur rapidly. Never leave the vehicle unattended with the slide room extended. If the vehicle is to be stored outside throughout the winter months, a full interior inspection for water leaks should be made bi-monthly. Extensive sealing has been performed at the factory; however, the inherent twisting and flexing that occurs while traveling may have compromised a seal or seam. All joints and seams should be inspected at least twice a year and recalced as necessary. Special attention should be directed toward the roof air conditioning seals, ceiling and plumbing vents, skylights, roof mounted antennas, windows, door molding, clearance lights and the beltline molding. Specific sealant products should be used in the areas for which they were designed. These items can be obtained from recreational vehicle parts suppliers. Listed below are some of the more common sealants and the areas in which they are used. Approved sealants are available at service centers and authorized dealers.



**WARNING: Products may contain hazardous materials which require special handling. Read labels carefully. Follow all product manufacturer's safety requirements.**

---

## Sealant Types

### Acryl-R:

This product is used on all roof openings such as vents and skylights, any roof mounted antennas, ladder roof mounts with the exception of the roof air conditioners. Sealant should be applied only where the equipment bases meet the roof. Clean old sealant (that is lifting) before applying with new. Make sure roof is dry and free of dirt. This product is usually found in a caulking tube. Care should be used when near an edge as product will spread out. Masking tape may be used to mask around area to avoid mishaps.

The roof air conditioners have closed cell foam base gaskets. No sealants are required. The roof air conditioners should be checked for tightness by the four mounting bolts located in each corner of the air conditioner roof opening. Torque specification is 40-50 in/lbs. The base gasket should be compressed to approximately 1/2".

### Clear Silicone Sealant:

Primarily this product is used on the sidewalls where a hole has been made and an item installed. This includes Windows, Doors, Handles, Beltline Molding, Latches and around bases of items surface mounted such as clearance lights. Old peeling sealant should be removed. Avoid using metal utensils as this will scratch the painted surface. Use nylon sticks or equivalent. Avoid using lacquer thinners or ketone based solvents as these can damage the painted surfaces. Be sure the surface is clean and dry before application. Cut tube at an angle with smallest usable opening. Avoid a heavy bead as a little goes a long way.

Use finger at a 45° angle on beaded surface to smooth out product. Do not moisten finger, use a disposable latex glove. Keep rags or paper towels handy for clean up. Use care when applying silicone. Plan ahead before starting a bead, looking for obstacles that may impede application.

**Black Urethane:**

This product is used for sealing the windshields. It was not designed to fill holes or other imperfections. Black urethane comes in a tube and it applies much in the same way as silicone does. Clean up involves using solvents such as paint thinner. Gloves are required as this material is hazardous.

**Acrylic Sealants (geocel 2300):**

This product is used where items are sealed under a painted surface such as the metal corners of the slide-out room. The material is specially formulated to allow paint adhesion.

**Spray Foam:**

This product is used to seal where a hole has been made for items such as water lines or wires are coming through a floor opening.

**Black Seam Tape:**

This is a sticky tape which comes on a roll. Black seam tape is used on the front and rear roof seams, as well as on the roof to the sidewall corners of the slide out room. Cut away old lifting tape. Surface should be clean and dry before a new application is made. This may be done in sections as needed.

---

The fabrics have been manufactured with the same quality you would expect to find in a furniture store. If the fabric is abused it can be damaged. Special care needs to be taken when your motorhome is exposed to a very humid climate for an extended period of time. Cover all upholstery and make sure window coverings are down to protect from sun damage.

Protect the fabric from any unnecessary exposure to moisture. The sofa, pillows, dinette cushions, living area chair, driver/passenger seating and window treatments have been treated with *Scotch Guard* to prevent overall water spots and soiling. Frequently used items will wear accordingly and may require more attention than those items not regularly used.

**INTERIOR**  
**- Fabrics**

Use the following guidelines for cleaning your upholstery fabrics.

- Water-based cleaners are not recommended.
- If a spill does occur, blot the soiled area. Do not rub it.
- Some solvents are not recommended since they may have an adverse reaction on specific backings of your upholstery fabric.
- To prevent overall soiling, frequent vacuuming or light brushing are recommended to remove dust and grime.
- Clean spots using a mild water-free solvent or dry cleaning product.
- Clean only in a well ventilated area and **avoid any product containing carbon tetrachloride** or other toxic materials.
- Use a professional furniture cleaning service for an overall cleaning.

**Fabric Cleaning Codes:**

The codes listed below refer to cleaning instructions recommended by the fabric manufacturer for specific fabrics. The “Fabric Specification Charts” (located on the following pages) list specific fabric codes under “Cleaning Code.”

“W” - Clean this fabric with the foam only of a water-based cleaning agent to remove the overall soil. Many household cleaning solvents are harmful to the color and life of a fabric. Cleaning only by a professional furniture cleaning service is recommended. To prevent overall soil, frequent vacuuming or light brushing to remove dust and grime is recommended.

“S” - Clean this fabric with pure solvents (petroleum distillate-based products such as *Energine*, *Carbona*, *Renuzit*, or similar products may be used) in a well ventilated room. Cleaning only by a professional furniture cleaning service is recommended.



**CAUTION: Use of water-based or detergent-based solvent cleaners may cause excessive shrinking. Water stains may become permanent and unable to be removed with solvent cleaning agents. Avoid products containing Carbon Tetrachloride as it is highly toxic. To help prevent overall soiling, frequent vacuuming or light brushing to remove dust and grime is recommended.**

“S/W” - Clean this fabric with the foam only of a water-based cleaning agent or with a pure solvent in a well ventilated room (petroleum distillate-based products such as *Energine*, *Carbona*, *Renuzit*, or similar products may be used). Cleaning only by a professional furniture cleaning service is recommended. To help prevent overall soiling, frequent vacuuming or light brushing to remove dust and grime is suggested.



**“P”** - The article is resistant against perchlorethene, cleaning benzine (spirit), white spirit, R-11 and R-13.

**“Dry Clean Only”** - Cleaning only by a professional dry cleaner or furniture cleaning service is recommended for this fabric.

**Machine Washing for 100% Polyester:**

**“Wash Cycle”** - Use synthetic setting and high water level with mild agitation. A mild soap or detergent in water not to exceed 160° F.

**No bleach or fabric softener.**

**“Drying”** - Use low temperatures, a synthetic setting of 85° F to 90° F maximum should be used. Do not exceed three to five minutes time on the synthetic cycle. If washed at 160° F, the maximum temperature which can be used to dry is 140° F. Hang or fold immediately after drying.

**“Finishing”** - If necessary, press as following:

- Iron on low setting (275° F) with damp cloth or steam iron using a dry press cloth.
- Grid Head press for short intervals with minimum steam. Do not lock the head.
- Flat bed press dampened drapery using cloth covering.
- Avoid prolonged contact with heat.

**Fabric Specification Chart**

Fabric	Where Used
<b>Wine Berry</b>	
Ramada Antique	Sofa, Din Cushion, LR Lambriquen
Tavistock Stipe Gold 28314 B3L	Chair, LR Pillow, LR Lambriquen
Waldorf 345 Wine	FSD, LR Pillow, LR Lambriquen
Singapore Antique	Bedsread, BR Pillow, BR Lambriquen
Stonigton Chianti	BR Accent, BR Pillow, Headboard, BR Lam
Dempsey Chablis	Windshield
RVAA New Oyster	Leather
Brunswick New Oyster	Vinyl
<b>Desert Sand</b>	
Caracal Sandalwood	Sofa, Din Cushion, LR Lambriquen, LR Pillow
Telstar Moss	Chair, FSD, LR Pillow, LR Lambriquen
Sun Valley Pewter KXF 7642-1	Bedsread, BR Pillow, BR Lambriquen
Macho Linen	BR Accent, BR Pillow, Headboard, BR Lam
Dempsey Chablis	Windshield
RVAA Taupe	RVAA Taupe
Brunswick Taupe	Vinyl
<b>Pacifica</b>	
Secret Service Cameo 29147-A2GU	Sofa, LR Pillow, Dinette Cushion, LR Lam
Windmill MO15366-006	Chair, LR Pillow, FSD, LR Lam
Neer/Rembrandt Bluebell	Bedsread
Mallard D Slate	Bedsread, BR Pillow, Bedroom Lam, Headboard
Dempsey Chablis	Windshield
RVAA New Oyster	Leather
Brunswick New Oyster	Vinyl

## Fabric Specification Chart Continued....

Fabric	Where Used
<b>Palm Harbor</b>	
970045 021-026	Sofa, LR Pillow, Din Cushion, LR Lambrequin
Aida 24231 MO26036-006	LR Pillow, Chair, FSD, LR Lambrequin
21028 74 Surf	Bedsread, BR Pillow, BR Lambrequin
Gleam Nile	BR Accent, BR Pillow, Headboard, BR Lam
Dempsey Chablis	Windshield
RVAA Pearl	Leather
Brunswick Pearl	Vinyl
<b>Pewter</b>	
Amelia Sage	Sofa, LR Pillow, Din Cushion, LR Lambrequin
Glamour 9603 MO16076-029	Chair, FSD, LR Pillow, LR Lambrequin
Mozart - FS Harmony	Bedsread, BR Pillow, BR Lambrequin
Shangtug - SH Vicksburg	BR Accent, BR Pillow, Headboard, BR Lam
Dempsey Chablis	Windshield
RVAA Quicksilver	Leather
Brunswick Quicksilver	Vinyl

LR = Living Room  
BR = Bedroom  
FSD = Free Standing Dinette

## Vinyl

Several areas of the motorhome can be covered in vinyl. These areas include the dash, items of furniture and the ceiling. The care and cleaning of these areas are outlined in the Morbern Vinyl section below.

### Morbern Vinyl:

Vinyl requires periodic cleaning to maintain its neat appearance and to prevent the buildup of dirt and contaminants that may permanently stain and/or reduce the life of the vinyl if they are not removed. The frequency of cleaning depends upon the amount of use and the environmental conditions in which the vinyl is subjected. The procedures used for cleaning are dependent upon the end-use circumstances.

### Normal Cleaning:

Most common stains can be cleaned using warm soapy water and clear water rinses. Moderate scrubbing with a medium bristle brush will help to loosen soil from the depressions of embossed surfaces. For stubborn stains use the following commercially available mild detergents in accordance with the manufacturer's instructions: *Mr. Clean* or *Fantastik*. Full strength rubbing alcohol or mineral spirits may be tried cautiously as a last resort on very stubborn stains if the above suggestions do not work. Indiscriminate use of any solvent, or solvent containing cleaner, can severely damage or discolor the vinyl. Stains may become permanent if they are not removed immediately. The procedure for removal of the more severe staining agents are outlined below.



**NOTE: Detergents should never be used on a regular or repeated basis for normal cleaning.**



**CAUTION: Powdered cleaners containing abrasives, steel wool and industrial strength cleaners are not recommended for Morbern vinyl.**

### Bird Excreta & Vomit Stains:

Sponge the area with soapy water containing a diluted bleach until the stain is removed. Rinse thoroughly with clean water.

### Urine Stains:

Sponge them with soapy water containing a small amount of household ammonia. Rinse thoroughly with clean water.

### Surface Mildew:

Wash with diluted bleach and use a soft brush for stubborn growth. Rinse repeatedly with clear, cold water.



**CAUTION:** Any lacquer solvent will cause immediate irreparable damage to the vinyl. Wax should never be used on any vinyl upholstery as it will cause premature embrittlement and cracking. Dilute chlorine bleach before using. Never use full strength bleach. If flammable solvents such as alcohol, turpentine or var-sol are used for cleaning, use only small quantities while in a well-ventilated area. Exercise proper caution by notifying any persons in the area. Keep away from any ignition source. Always wear protective gloves.

**Ballpoint Ink:**

Permanent Marker Ink spots will stain the vinyl permanently. Wipe the stain immediately with rubbing alcohol in a well ventilated area to remove much of the stain.

**Oil-Base Paint:**

Use turpentine in a well ventilated area to remove any fresh paint. Dried paint must be moistened using a semi-solid, gel-type stripper. The softened paint can be gently scrape away. Rinse with soap and water.



**NOTE:** Paint strippers will remove the print pattern and damage the vinyl if it comes in direct contact.

**Latex Paint:**

Fresh paint can be wiped off with a damp cloth. Hot soapy water will normally remove dried latex.

**Tar or Asphalt:**

Remove immediately. Prolonged contact will result in a permanent stain. Use a cloth lightly dampened with mineral spirits and rub the stain gently, working from the outer edge of the stain toward the center to prevent spreading. Rinse with soap and water.

**Crayon, Mustard or Ketchup:**

Sponge with mild soap and water. For stubborn stains that may have set use a cloth soaked in diluted mild detergent with gentle rubbing. Any remaining stain should be washed with diluted bleach. Rinse repeatedly with cold water.

**Chewing Gum:**

Scrape off as much gum as possible using a dull knife. Rub the gum with an ice cube to harden and make it easier to remove. In a well ventilated area use a cloth saturated with mineral spirits and gently rub the remaining gum. Rinse thoroughly with clean water.

**Lipstick, Grease, Oil, Make-Up or Shoe Polish:**

Apply a small amount of mineral spirits with a cloth. Rub gently. Be careful not to spread the stain by smearing it beyond its original source. Remove shoe polish immediately as it contains a dye which will cause permanent staining. Rinse thoroughly with clean water.

**Candy, Ice Cream, Coffee, Tea, Fruit Stains, Liquor, Wine, Tanning Lotion or Soft Drinks:**

Use lukewarm water and sponge repeatedly. Any loose material should be gently scraped with a dull knife. Any soiled area that remains after drying should be gently rubbed with a cloth dampened with a mild detergent solution. Rinse thoroughly with clean water.

**Blood or Plant Residue:**

Rub out any spots with a clean cloth soaked in cool water. If stubborn spots remain use household ammonia and rinse repeatedly with a clean, wet cloth. Do not use hot water or soap suds. This will set the stain.



**NOTE: Vinyl requires periodic cleaning to maintain its appearance and to prevent the buildup of dirt and contaminants that may permanently stain or reduce the life of the vinyl if left untreated. The frequency of cleaning and procedures used depend upon the amount of use and the environmental conditions in which the vinyl is subjected. Vinyl tears or holes can be temporarily covered with clear “office” tape to prevent further damage. Repairs should be made by a professional upholstery shop. Commercial repair products may contain laquers and cause the vinyl to become brittle and more difficult to repair**

---

**Leather**

**Spots & Spills:**

Absorb excess liquid immediately with a clean cloth or sponge. Use water only if necessary. Do not use a cleaning product. If water is used, clean the entire area where the spot occurred. An example would be the entire seat cushion, or the entire arm. Let it air dry. Do not dry the wet areas with hair dryers, etc.

**Stubborn Spots and Stains:**

Use lukewarm water and a mild soap to work up a thin layer of suds on a piece of cheesecloth. Scrub the surface. Rinse with a piece of clean, damp cheesecloth. Let air dry. Do not use saddle soap, cleaning solvents, furniture polish, oils, varnish, abrasive cleaners, soaps or ammonia water.



**NOTE: These are recommended or suggested methods of cleaning. The manufacturer is not responsible for damage incurred while cleaning. Always test the cleaning method in an inconspicuous area first before applying to the entire area.**

## Floors -Carpet Cleaning

Use the solution specified in order from 1-6 until stain is removed.	A DRY CLEANING FLUID	B NAIL POLISH REMOVER	C DETERGENT SOLUTION	D WARM WATER	E VINEGAR SOLUTION	F AMMONIA SOLUTION	G SPOT REMOVAL KIT	H CALL PROFESSIONAL	I PERMANENT CHANGE
<b>SPOTS</b>									
Acid				2		1	3	*	
Acne Medication		1	2	5	4	3	6	*	
Alcoholic Beverage			1	4	3	2		*	
Ammonia			2	1				*	
Bleach		1	2				3	*	
Blood		1	3		2	4			
Candle Wax	1					2			
Cement & Glue	2	1	3		5	4	6		*
Chalk		1	2						
Charcoal		1	2						
Chewing Gum	1								
Coffee			1	3	2		4	5	*
Cosmetics		2	1	3	6	5	4	7	*
Crayon	1		2	3					
Drain/Toilet Cleaner			2	1	3			4	*
Dye	1		2		4	3	5	6	*
Food			1	4	3	2	5	6	*
Fungicides/Insecticides/Pesticides	1		2	5	4	3	6	*	
Furniture Polish (Water Based)			1	4	3	2	5	6	*
Furniture Polish (Solvent Based)	2	1	3	6	5	4	7	8	*
Furniture Stain	2	1	3	6	5	4	7	8	*
Graphite		1	2						
Grease	1	2	3				4	5	*
Ink	2	1	3	6	5	4	7	8	*
Iodine	1		2	5	4	3	6	7	*
Lipstick	2	1	3	6	5	4	7	8	*
Medicine	2	1	3	6	5	4	7	8	*
Merthiolate			1	4	3	2	5	6	*
Nail Polish	2	1	3				4	5	*
Oil	1		2	4		3		5	*
Paint	2	1	3				4	5	*
Plant Food			1	4	3	2	5	6	*
Rust			2	3	1		4	5	*
Shoe Polish	2	1	3	5		4	6	7	*
Soft Drinks			1	4	3	2	5	6	*
Soot	1		2	3				4	*
Tar	1						2	3	*
Toothpaste			1						
Urine			1		2		3	4	*
Vomit			1	4	3	2	5	6	*

## Spot Removal Procedures

- Act quickly when anything is dropped or spilled. Remove spots before they dry.
- Blot liquids with a clean, white absorbent cloth or paper towel.
- For semi-solids, scoop up with a rounded spoon.
- For solids, break up and vacuum out as much as possible.
- Pretest the spot removal agent in an inconspicuous area to make certain it will not damage the carpet or its dyes.
- Apply a small amount of the cleaning solution recommended for the particular spot. Do not scrub. Work from the edges of the spot to the center. Blot thoroughly. Repeat until spot is removed.
- Follow steps on the **Carpet Spot Removal Guide**.
- After each application, absorb as much as possible before proceeding to the next step.
- Absorb remaining moisture with layers of white paper towels, weighted down with a non-staining glass or ceramic object.
- When completely dry, vacuum or brush the pile to restore texture.
- If the spot is not completely removed contact a professional carpet cleaner.

## Cleaning Solutions

**(A) Dry Cleaning Fluid:** A nonflammable spot removal liquid, available in grocery and hardware stores.

**(B) Nail Polish Remover:** Any acetate, which often has a banana fragrance. Do not use if it contains acetone.

**(C) Detergent Solution:** Mix two cups of cold water and 1/8 teaspoon mild liquid detergent (no lanolin, non-bleach).

**(D) Warm Water:** Lukewarm tap water.

**(E) Vinegar Solution:** One cup white vinegar to one cup water.

**(F) Ammonia Solution:** One tablespoon household ammonia to one cup water.

**(G) Spot Removal Kit:** Available from retail carpet stores or professional cleaners.

**(H) Call Professional:** Additional suggestions, special cleaning chemicals or the ability to patch the area might be available.

**(I) Permanent Change:** Due to the nature of the stain, there may be color loss. The carpet has been permanently dyed or the carpet yarns have been permanently damaged.



**NOTE: While the recommended cleaning agents have proven to be effective, some stains may become permanent.**

---

## Tile

Regular maintenance is all it takes to keep the tile in the motorhome looking showroom new. When using your slide-out, be sure to clean the tile floor when the slide out is extended to prevent dirt from scratching your tiles when the slide out is retracted.

### **Cleaning Tile:**

Clean tiles with a damp sponge mop or cloth to maintain their luster. If moderate staining occurs, cleaning with a window cleaner such as *Windex* should do the job. If you prefer, you can use a mild solution of hot water and all purpose cleaner for tile floors, walls and countertops. Rinse with clear water and be sure to dry with a soft cloth to prevent streaking. Avoid cleaning tile with soap. Soap forms a film to dull the luster. Soap also promotes the growth of mildew and bacteria.

If the grout requires cleaning, scrub with a plastic brush. Do not use steel wool as small particles may remain and produce unsightly stains. Powdered cleaners should not be used on unglazed tile floors. Undissolved powder will dull the surface. In addition, sealers are not recommended on unglazed tiles. With the exception of terracotta, which may be oiled or waxed, you won't need to polish or buff the tiles to maintain their finish.

### **Cleaning Shower:**

Showers are susceptible to hot water and soap build up. Showers should be cleaned weekly to prevent burdensome clean-up. Using the same solution used to clean tile floors will be sufficient for the shower. However, to control mildew growth you should spray the shower with household chlorine bleach and allow it to stand for five minutes. Weekly cleaning of glass shower doors with window cleaner should maintain the shine. If you have water build up and



cannot remove spots from the glass, rubbing lightly with a razor blade will remove the deposits.

To prevent excessive moisture and a continual growth of mildew, use the shower only with adequate ventilation. The sealant in a regularly used shower should be replaced once a year. To accomplish this, use a sharp instrument to remove the old sealant. Apply a new sealant, which can be found at an RV supply store.



**NOTE: Before using any solution to clean your tile check the manufacturer's warning label to insure the products safety. If you have any doubt, test the solution in an inconspicuous place.**

Make solution in a small quantity. Mix together in equal parts: warm or hot water, white vinegar, bleach and club soda. Spritz on and blot. Do not rub.

## Ceiling

Time is very important when removing substances from wall coverings that are solvent based or contain color. Do not use abrasive cleaners containing chlorine bleach or solvents. (*Fidelity* and *Jolie* brands are recommended.) Always begin with a mild detergent or soap and warm water. To remove normal dirt clean with a soft sponge. Rinse and wipe it dry.

### Care for the Satinesque Wall Covering:

## Wall Coverings

Any stain should be removed as quickly as possible to minimize reaction between the staining agent and the wall covering. Time is very important when removing substances that are solvent based or contain color. Examples: nail polish, oil, shampoo, lacquer, enamel, paint, ink and lipstick.

Always begin cleaning with a mild detergent such as soap. If necessary, move to a stronger cleaner such as household bleach, liquid household cleaners or rubbing alcohol. Before using one of the stronger cleaners test the cleaning agent on a small inconspicuous portion of the wallcovering first confirm that the cleaner does not affect the color or gloss of the wall covering.

### Normal dirt:

Remove normal dirt using a mild soap or detergent and warm water. Allow it to soak for a few minutes. Rub briskly with a cloth or sponge.

### Nail polish, Shellac, or Lacquer:

Remove liquid using a dry cloth. Use care not to spread the stain. Quickly clean the remaining stain with rubbing alcohol. Rinse with clean water.

### Ink:

Remove immediately by wiping with a cloth dampened in rubbing alcohol. Rinse with clean water.

**Chewing gum:**

Rub the gum with an ice cube to cool and harden it. Gently, pull off the bulk of the gum. Remove any remaining gum with rubbing alcohol.

**Pencil:**

Erase as much of the pencil mark as possible. Wipe any remaining marks with rubbing alcohol.

**Blood, Feces or Urine:**

Remove these staining substances as quickly as possible. Wash the stained area with a strong soap. If the stain does not disappear, rinse the soapy area thoroughly with clean water. Mix a solution of 50% water and 50% household bleach. Clean the stained area with the bleach solution. Rinse with clean water.

**Care for the Tower Wall Covering:**

Remove ordinary stains with mild soap and warm water. Sponge it on. Rinse well and dry with a soft cloth.

Special cleaning problems: To remove ball point pen, blood, lipstick, etc., use a sponge or soft bristle brush and *Formula 409*, *Fantastik* or a similar product. Rinse well and dry. Finish cleaning by applying full strength isopropyl alcohol with a sponge or soft brush. Rinse well and dry.

---

**Countertops**

The Solid Surface was created for a lifetime of easy care. Just follow the simple guidelines listed here to keep your surfaces looking good.

**Routine Care:**

The motorhome countertops are finished with one type of finish: matte/satin. All solid surface sinks and bowls have the matte/satin finish. Soapy water or ammonia-based cleaners will remove most dirt and stains from all tops and bowls. However, slightly different techniques must be used to remove different stains. Follow the recommendations below.

**Cleaning Countertops:**

- Most dirt and stains: Use soapy water or ammonia-based cleaner.
- Water marks: Wipe with damp cloth and towel dry.
- Difficult stains: Use soft scrub and a Grey *Scotchbrite* Pad.
- Disinfecting: Occasionally wipe surface with diluted household bleach (one part water and one part bleach).

**Cleaning Solid Surfaces Sink:**

Occasionally clean by using *Soft Scrub Liquid Cleanser* and a Grey *Scotchbrite* Pad. Scrub the sink, rinse and towel dry. Do this as often as you feel necessary.

**Removing Cuts and Scratches:**

Because the beauty of the surface goes all the way through the Solid Surface the countertops are completely renewable. Use the following instructions to remove minor cuts and scratches.

- Sand with 180 grit and then 320 grit sandpaper until the scratch is gone.
- Restore the finish using a Grey *Scotchbrite* Pad. Never sand hard in one small area. Feather out lightly to blend restoration.

**Preventing Heat Damage:**

The Solid Surface withstands heat better than ordinary surface materials; however, hot pans and some heat-generating appliances, such as frying pans or crockpots, can damage the surface. To prevent heat damage, always use a hot pad or a trivet with rubber feet to protect the surface. In most cases the surface can be repaired if it is accidentally damaged.

**Other Important Tips:**

Avoid using strong chemicals on the Solid Surface such as paint removers and oven cleaners. If these come in contact with the Solid Surface quickly wash with water. Avoid contact with nail polish or nail polish remover. If contact is made quickly wash with water.



**NOTE: Do not cut directly on the solid surface. Always run cold water into the Solid Surface sink when pouring boiling water into the sink.**

**Water Spots:**

Any glass will develop water spots if the glass is not cleaned properly. A spotting effect is magnified when the glass has a reflective finish. Use a squeegee immediately after washing to reduce water spotting. To remove stubborn water stains from reflective glass we recommend *Cerium Oxide Polishing Compound*, made by C.R. Lawrence, available at most glass shops.

**Windows****Condensation:**

Condensation is a natural phenomenon. The amount of condensation will vary with climate conditions, particularly in relative humidity. Condensation occurs from water vapor present in the air. Each of us add more vapors by breathing, bathing, cooking, etc. Water vapor collects wherever there is available air space. When the temperature reaches the dew point the water vapor in the air condenses and changes to liquid form.

**Controlling Moisture Condensation:**

Reduce or eliminate interior moisture condensation during cold weather by taking the following steps:

- Partially open the roof vents and windows so that outside air can circulate into the interior. Increase the ventilation when larger numbers of people

are in the motorhome. Even in raining or snowing conditions the air outside will be far drier than the interior air.

- Install a dehumidifier. Continuous use of a dehumidifier is effective in removing excess moisture from the interior air. Using a dehumidifier is not a cure-all, however, it will reduce the amount of outside air needed for ventilation.
- Run the range vent fan when cooking and the bath vent fan (or open the bath vent) when bathing, to reduce water vapor. Avoid excessive boiling or use of hot water as it produces steam.
- Do not heat the motorhome interior with the range or oven. Heating with the range or oven increases the risk of toxic fumes and allows oxygen depletion. Also, open flames add moisture to the interior air increasing condensation.
- In very cold weather leave the cabinet and closet doors partially open. The air flow will warm and ventilate the interior of the storage compartments and the exterior wall surface, reducing or eliminating condensation to prevent the possibility of ice formations.

---

### **Mini-blinds**

- To maintain the mini-blinds on a frequent basis, vacuum with the brush attachment or use a dusting tool (available on the market) designed specifically for mini-blinds.
- Wash the mini-blinds with mild soap and water in a tub, or hang the blinds on a fence or wall and gently rinse them with a hose.

---

### **Day/Night Shades**

The day/night shades are made of a polyester blended material. Use the following guidelines to care and maintain the day/night shades:

- Vacuum with a brush attachment, or use a dusting tool on a regular basis.
- Use a weak solution of dish soap and water to spot clean the blinds with a slightly damp cloth. Avoid soaking or saturating the shades with water. This will break down the finish of the shade.
- When not in use, leave the shades folded up. This helps to hold the shape of the pleats.
- String tension for the shades should be equal. The tension can be adjusted if the shades will not remain folded up.

**NOTES**

# Diplomat

<b>INTRODUCTION • 90</b>	<b>SECTION 4 APPLIANCES</b>
<b>REFRIGERATOR • 90</b>	<b>FURNACE • 103</b>
<i>Operation Specifics • 91</i>	<i>Operation • 104</i>
<i>Tips • 91</i>	<i>Using the Furnace • 104</i>
<i>Refrigerator Controls • 92</i>	<i>Tips • 105</i>
<i>Alarm • 92</i>	<i>If Furnace Fails to Light • 105</i>
<i>Doors • 92</i>	<i>Bathroom Exhaust Fan • 105</i>
<i>Control Panel • 93</i>	<i>Kitchen Exhaust Fan • 105</i>
<i>Manual Mode Operation • 93</i>	<b>WATER HEATER • 106</b>
<i>Auto Mode Operation • 93</i>	<i>Before Using the Water Heater • 106</i>
<i>Ice Maker Operation (Optional) • 94</i>	<i>Tips • 107</i>
<i>High Humidity Operation • 94</i>	<i>Water Heater - Using LP-Gas • 107</i>
<i>Cooling Unit Fans (four door models) • 94</i>	<i>Water Heater - Using 120 AC • 107</i>
<i>Defrosting the Refrigerator • 94</i>	<i>Tips • 107</i>
<i>Cleaning the Refrigerator • 94</i>	<i>Troubleshooting - LP-Gas Operation • 108</i>
<b>MICROWAVE OVEN • 94</b>	<i>Troubleshooting - Electric Operation • 108</i>
<i>Operation • 95</i>	<b>WASHER-DRYER PREPARED • 108</b>
<i>Microwave Cooking • 97</i>	<b>WASHER-DRYER (Optional) • 109</b>
<i>Convection Cooking • 98</i>	<i>Operating Instructions • 109</i>
<i>Tips • 99</i>	<i>Cleaning the Drain Screen • 110</i>
<i>Care &amp; Cleaning • 100</i>	<i>Winterizing the Washer-Dryer • 110</i>
<b>COOKTOP • 100</b>	<i>Cleaning the Washer-Dryer • 111</i>
<i>Tips • 101</i>	
<i>Care &amp; Cleaning • 101</i>	
<b>AIR CONDITIONER • 102</b>	
<i>Heat Pump • 103</i>	
<i>Operation • 103</i>	
<i>Return Air Filters • 103</i>	

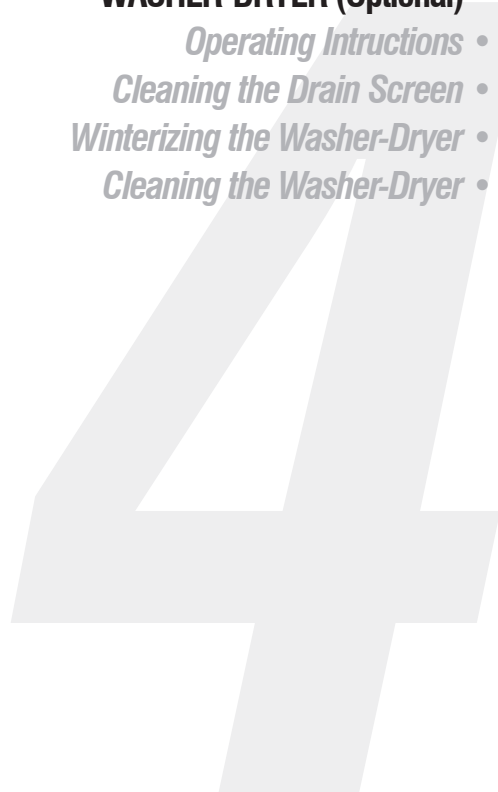



## INTRODUCTION

This section covers operation and care of various appliances found in the motorhome. The motorhome is equipped with a refrigerator, cooktop or range/oven, microwave, furnace, water heater, roof air conditioner and several optional appliances. Many of these appliances operate on AC or DC current, LP-Gas or a combination of all three.



**Detailed information with CAUTION or WARNING instructions for the various appliances, other than what is found in this section, can be found in the manufacturer's manual.**



**WARNING: Before entering any type of refueling station make sure all LP-Gas operated appliances are off. Most LP-Gas appliances used in recreational vehicles are vented to the outside. When parked close to a gasoline pump it is possible for fuel vapors to enter this type of appliance and ignite, resulting in an explosion or fire. Carbon monoxide gas may cause nausea, fainting or death. Operating an LP-Gas appliance with inadequate ventilation or partial blockage of the flue can result in carbon monoxide poisoning. Do not store flammable liquids such as lighter fluid, gasoline or propane in the outside refrigerator compartment.**

The refrigerator in the motorhome operates on a different principle than a standard household refrigerator. Knowing these differences should answer questions or solve problems that may arise. A standard household refrigerator uses a different type of refrigerant. The compressor will pump refrigerant vapor into a condenser where the heat from the refrigerant will be dissipated and the vapor will change to a liquid. The liquid refrigerant is pumped through a metered orifice or capillary tube at the evaporator. At this time the refrigerant changes from liquid to a vapor. This change cools the evaporator. Air is then blown across the evaporator and into the interior of the refrigerator. This system is efficient as long as 120 Volts AC is available; however, this does not allow the freedom a recreational vehicle is designed to give. The recreational vehicle refrigerator uses a combination of fluids and gas for refrigeration: ammonia, water, sodium chromate and hydrogen gas. This combination is put into a pressurized cooling unit at approximately 350 psi. It is heated to a gaseous state, which then rises to the top of the cooling unit into a condenser where it forms droplets as it cools. As the vapor condenses it will “extract or absorb” heat out from the inside of the refrigerator. Using gravity the droplets return through the absorber coils to the absorber vessel to start the process again. The cooling unit has specific guidelines that need to be followed for proper operation and insured longevity. Keeping these guidelines in mind should give years of faithful troublefree service.

## REFRIGERATOR



## Operation Specifics

The refrigerator operates from either LP-Gas or 120 Volts AC electric. Controls are electronic which require the DC Voltage to be no higher than 15.4 Volts DC or lower than 10.5 Volts DC. The AC voltage limits are 132 Volts AC (Volts Alternating Current) maximum and 108 Volts AC minimum. The refrigerator (from front view) needs to be leveled within 3° side to side and 6° front to back. Using a torpedo or bulls eye (fence post) level, place the level onto the freezer plate. The level should be within the circle by a half of a bubble. Generally, this is within comfortable living conditions. The heat source for the cooling unit is supplied by an electric heating element or an LP-Gas flame. The heat source, which is calibrated in BTU's (British Thermal Units), is concentrated to a specific area of the cooling unit. Refrigerator operation in an "off level" condition separates the sodium chromate and crystallize from the heat source which blocks the recirculation action of the cooling unit and causes accumulative, irreparable damage. The LP side of the refrigerator and the LP-Gas pressure need to be serviced yearly, depending on use. Over time the BTU rating can change, which will affect the refrigerator's performance. Ambient air temperature and humidity can also affect its performance and function. The BTU rating lowers when operating LP-Gas at an altitude higher than 5,500 feet. This affects the refrigerator's performance. If possible, switch mode operation to 120 Volts AC electric while at a higher altitude.



**WARNING: Do not use the refrigerator if there is an ammonia smell inside or outside of the refrigerator, or if a yellowish substance appears inside the box or in the outside access compartment. This can be an indication of a refrigerant leak. Contact an authorized repair facility.**

## Tips

- If possible, cool items first before putting them into the refrigerator.
- Keep the doors shut. Think about what you want before opening the doors.
- Allow the refrigerator 24 hours of operation before actual use to help it get a "head start" with the refrigeration process.
- A box of open baking soda will help absorb food odors. Wipe up any spilled soda.

The 120 Volt AC mode of the refrigerator can be operated by the inverter. This feature will keep the refrigerator contents cool while traveling.

To enable this feature:

1. Turn the inverter ON.
2. Turn the refrigerator ON. Select AC power operation.



**NOTE: Use this feature only when the engine is running. Failure to disable this feature with the engine off will result in dead house batteries. Hook to shore power or turn the inverter off and switch the refrigerator to LP-Gas operation.**

## Refrigerator Controls

The refrigerator controls are DC (direct current) operated through an electronic circuit board. The refrigerator which operates from heat, as described above, gets its heat source two different ways: an electric heating element or a flame from LP-Gas. Mode operation and temperature selection is made by controls on the face of the refrigerator. In order for the refrigerator to operate the house batteries must be charged, the LP-Gas valve on, the water valve on (ice maker option only) and the refrigerator AC cord plugged in (located in outside refrigerator access door). If the controls do not light up check the house batteries charge status or see if the 12 Volt wires are plugged into the refrigerator's circuit board (outside in refrigerator access door).

The refrigerator uses an audible alarm that will sound for the following reasons:

### Alarm

1. DC or AC voltage is higher or lower than allowed specifications.
2. Refrigerator is set to auto mode and the 120 Volts AC is discontinued.
3. Liquid Petroleum Gas mode fails to light initially or fails to light after a period of operation.
4. Door has been left open longer than two minutes.
5. The circuit board detects a failure resulting in a code being displayed.



**NOTE: If the alarm sounds, note the code in the LED display and turn the refrigerator off to silence the alarm. Refer to the manufacturer's manual for the list of codes and their meanings.**



**NOTE: Keep the interior box temperature at or below 54° F to reduce the possibility of food spoilage. The refrigerator works harder to keep a low box temperature, especially in hot, humid climates. Low box temperature may also add quicker frost build-up.**



**WARNING: Make sure all flames are extinguished and the LP-Gas valve is off before refueling. LP-Gas and gasoline are highly flammable which can ignite, resulting in an explosion, fire or death. Many states have passed laws regarding having the LP-Gas valve open while traveling. Know the laws for the particular state in which you are traveling.**

The refrigerator doors are positive lock style doors that close with a "click" to prevent accidental door opening while traveling. When storing the motorhome the refrigerator doors have a storage position that locks the doors partially open. This will help reduce odor from mold and bacteria build-up. Use this feature. A completely closed up refrigerator in storage is a perfect habitat for molds and bacteria to grow. To use the storage feature, open doors approximately halfway and slide the latch into the cut-out of the strike plate.

### Doors

### Control Panel-1200 Series

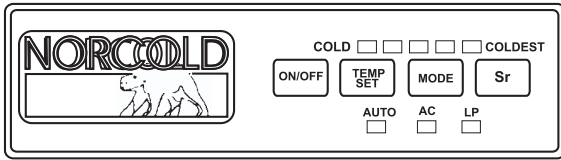

The Refrigerator Control Panel requires 12 Volt DC to operate.

**ON/OFF Button** - Press this button to turn the refrigerator ON. Press and hold this button to turn the refrigerator OFF.

**LED Display** - This screen is used for fault code display.

**MODE Button** - Press and hold this button to cycle the refrigerator through the different modes available: AUTO, AC and LP modes. Release the button when the desired mode is displayed.

**TEMP SET Button** - Press and hold the button to select the desired temperature setting. Five settings are available from COLD to COLDEST.

### Control Panel-900 Series

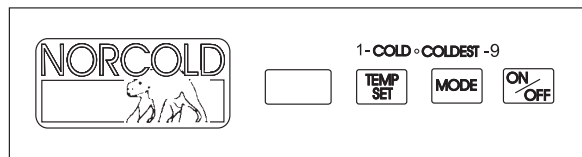

**LCD Display** - Window has a light which illuminates when any button is pressed and remains on for 10 seconds after button is released.

**ON/OFF Button** - Press button to turn refrigerator ON. Press button and hold until no lights are lit to turn refrigerator OFF.

**MODE Button** - Pressing and holding button allows user to cycle through four choices: one "AUTO" and three manual modes (AC, LP GAS or optional BATT). Refrigerator will not switch to new operating mode until button is released.

**TEMP SET Button** - Press and hold button to select desired temperature setting. Temperature settings appear in display window with shortest thermometer reading indicating coldest setting.

### Manual Mode Operation

This mode will lock the refrigerator into either LP-Gas or electric AC operation. Press and hold the **MODE** button until LP or AC is displayed. Release when the desired function is lit. The Alarm will sound and a code will be displayed if the function selected is interrupted or a failure occurs. Note the code and turn the refrigerator off to silence the alarm. Refer to the manufacturer's manual for a list of codes and their meanings.

### Auto Mode Operation

This feature will automatically select 120 Volts AC over LP-Gas operation. If 120 Volts AC is available it will use this source for operation until AC service has been discontinued. Once AC is discontinued the alarm will sound and the refrigerator will automatically switch to LP-Gas operation. If the refrigerator fails to light the alarm will sound and a code will be displayed.

Press and hold the **MODE** button until **AUTO** is displayed; release the button. Press and hold the **TEMP SET** button until desired temperature is displayed; release button. In **AUTO** mode, AC or LP will remain lit for 10 seconds upon initial start or when mode has changed.

**Ice Maker  
Operation  
(Optional)**

The ice maker works from 120 Volts AC only. The ice maker will start to function only after the freezer temperature is low enough. City water or the water pump must be on and the valve (located in vanity cabinet) for the water supply line to the ice maker must be on. Pulling the metal arm (bail) down will turn the ice maker on. Pushing the arm up will turn the ice maker off.

If the ice maker is in operation while the motorhome is in motion water may spill out of the ice tray. **Raise the ice maker arm to stop ice production while the motorhome is in transit.**



**NOTE: Do not use the first one or two trays of ice if the refrigerator has been in storage. Ice cubes may have contaminants. Do not operate the ice maker without water pressure supplied to the refrigerator. This can cause damage to the ice maker assembly.**

The refrigerator is equipped with a heating element located in the flapper on the left door (four door model) or in the door (two door model). The heating element is activated when the refrigerator is turned on to any mode to help prevent moisture build-up in high humidity conditions.

**High Humidity  
Operation**

The cooling unit is equipped with a pair of cooling fans to help pass air across the cooling unit. These fans start automatically and will be audible when in operation.

**Cooling Unit Fans  
(four door models)**

Turn the refrigerator off and remove all items. Leave the drip tray under the cooling fins. **Do not** use heating guns, hair dryer or sharp objects to remove frost build-up as these can damage the interior. Leave all doors open. Defrost time can be shortened using trays of warm water. Wipe off excess water using paper towels or cotton cloth.

**Defrosting the  
Refrigerator**

Wipe using only cotton or paper towels. Products such as *FORMULA 409*, *DAWN* and *FANTASTIK* are acceptable cleaners. Do not use scouring pads or abrasive cleanser as these can damage the interior finish.

**Cleaning the  
Refrigerator**

The microwave oven is operated from 120 Volt AC supplied by either shore power, the generator or the inverter. Microwaves heat food by using sound waves generated at a very high frequency (2,450 MHZ) to agitate the water molecules inside the item being heated. The higher the water content is to solids the faster the response or the shorter the cooking time. Inside the microwave is a turntable that rotates when the microwave is operating. This will help heat the food evenly. The turntable can be turned off if a baking dish or other large item is used. The microwave is designed to sit over a range or cooktop. When cooking from the cooktop use the microwave's two speed ventilation fan. The fan draws air in from the bottom of the microwave through a pair of grease filters, then discharges the filtered air out through a

**MICROWAVE  
OVEN**

charcoal filter at the top. The ventilation fan is controlled by a thermostat and activates automatically from heat produced by the cooktop.

The microwave offers many different features. Some include varied cooking times with different power settings; automatic sensor cooking, a kitchen timer, metric to American conversion chart (which includes temperature and weight), on screen programming help, childproof lockout and auto defrost cycles. The screen can display one of three different languages.

The microwave/convection oven operates from 120 Volt AC supplied by either shore power, the generator or the inverter. The microwave/convection oven has the ability to cook food with heat like an electric oven, or preheat the oven with heat and cook with microwaves. Other features include the ability to cook with microwaves and convection at the same time, sensor cooking and a built-in broiler.



**WARNING: If a fire flares up when using the cooktop, turn off the ventilation fan. The fan may spread the flame. If the ventilation fan has started automatically from a heated cooktop it can not be manually turned off. Turn off the microwave AC circuit breaker to prevent the flame from getting up into the microwave and spreading the fire.**



**NOTE: When cooking in convection mode try to avoid using the inverter as the AC power source due to the high rate of battery consumption.**



**NOTE: When AC power is discontinued the clock time will be erased.**

The microwave operates on 120 Volt AC power which is supplied from either shore power, the on-board generator or the inverter.

---

## Operation



**NOTE: The microwave is for food preparation only. Do not use the microwave to dry clothes, newspapers, shoes or other items.**

### Safety Lock:

The microwave comes with a safety lock feature. This feature prevents the oven from operating accidentally. To use this feature:

- Press the **CUSTOM HELP** pad.
- Press the **1** pad.
- Press the **START/TOUCH-ON** pad.

The oven is now locked. If any button is pressed the word **LOCK** appears on the screen. The fan and hood light is still operational with the Safety Lock feature on. To return the oven to normal operation:

- Press the **CUSTOM HELP** pad.
- Press the **1** pad.
- Press the **START/TOUCH-ON** pad. The oven will resume normal operation.

**Setting The Clock:**

- Press the **STOP/CLEAR** pad.
- Press the **CLOCK** pad.
- Enter correct time in sequence using the number pads.
- Press the **CLOCK** pad to begin time.

**NOTE: The clock is a 12 hour clock only.**

**Kitchen Timer:**

- Press the **KITCHEN TIMER** pad.
- Using the number pads enter minutes and seconds, or 00 if no seconds.
- Press the **START/TOUCH-ON** pad to begin timer. Timer end will be signaled by one long beep.

**Press the STOP/CLEAR pad to:**

- Erase, if you make a mistake during programming.
- Cancel the kitchen timer.
- Stop the oven temporarily during cooking.  
(Press the **START/TOUCH-ON** pad to resume.)
- Return the time of day to the display.
- Cancel a program during cooking (touch the pad twice).

**Turntable On/Off:**

- Press **TURNTABLE ON/OFF** pad to stop or start the turntable.
- Enter the cook time desired minutes and seconds.
- Enter power level desired.
- Press the **START/TOUCH-ON** pad.

**Hood Light:**

To turn the hood light on or off touch the **LIGHT** button.

**Ventilation Fan:**

Press the **FAN HI/LO** button once for high, twice for low and three times for off.



**Microwave - Timed Cooking:**

The maximum amount of cooking time is 99 minutes and 99 seconds. Be sure to enter minutes and seconds. If seconds are not desired, enter 00.

---

**Microwave Cooking**

Press and hold the **START/TOUCH-ON**. The microwave pad operates at 100% power until the pad is released. This mode can be used for up to three minutes and up to three consecutive cycles.

**One Minute Cook Times:**

Press the **MINUTE PLUS** pad if one minute at full power is desired or to add one minute intervals to cooking time. The **MINUTE PLUS** pad must be pressed within one minute of closing the door, or during selected cooking time. For safety, the minute plus feature will lock out if there is no microwave activity within one minute of closing the door. Use the **START/TOUCH-ON** pad to reset the one minute safety period.

**Microwave Settings:**

To use 100% power, enter cook time by pressing the number pads. Press the **START/TOUCH-ON** pad to begin cook time.

To use settings lower than 100% power, use the number pads to enter desired cooking time. Press the **POWER LEVEL** pad. Use the number pad to select desired power level. Press the **START/TOUCH-ON** pad to begin cook time.

**Multiple Sequence Cooking:**

If sequential cooking times with varied power levels are desired, press the **POWER LEVEL** pad and select desired power level. Use the number pad to enter cook time for the first interval. Press **POWER LEVEL** pad again, select desired power level, then enter cook time for the next time period. Press the **START/TOUCH-ON** pad to begin sequential cooking. The microwave can hold up to four sequential cook time periods. If full power is desired in any of the time periods, skip the power level step and 100% power is automatically selected.

**Keep Warm:**

Press the **KEEP WARM** pad during cooking time to automatically keep food warm for up to 30 minutes after cooking time has expired. To use this feature after cooking time has expired or after the food has been removed, place the food back into oven and press the **KEEP WARM** pad.

Defrosting can be done on manual time selection or use the microwave's CompuDefrost.

**Manual Defrost:**

Press the **POWER LEVEL** pad. Select number 3 for defrost power. Enter desired defrost time. Be sure to stir or break food apart at regular intervals.

**CompuDefrost:**

The microwave has automated defrost programs for different foods and weights. Press the **COMPUDEFROST** pad to enter this mode. Press **COMPUDEFROST** again to select between ground meat, steak or chicken. Use number pads to enter weight of food being defrosted. Press **START/TOUCH-ON** to begin defrost cycle.

**Sensor Cooking:**

The microwave has electronic sensors that sense moisture or humidity given off by the food during the cooking process. Electronic sensors will be affected if room temperature exceeds 95° F. To adjust the sensor cooking mode to allow for more or less cooking time, press the **SENSOR COOK** pad. Press the **POWER LEVEL** pad once to increase cooking time or twice to decrease cook time.

To use the sensor cooking mode press the **SENSOR COOK** pad. Select the number or food desired from the library listed adjacent to the **SENSOR COOK** pad. Press the **START/TOUCH-ON** pad to begin sensor cooking.

The interior of the microwave produces heat just as it does in a regular oven. The convection cooking mode has special options such as a broil mode, the ability to preheat oven by convection and use of microwaves to complete cooking or to preheat.

**Convection  
Cooking**

**NOTE: When using the convection oven feature leave the turntable in place and do not restrict the rotation. This can damage the microwave.**

**Cooking with Convection:**

Press the **CONVEC** pad. Press the numbered pad with the desired cooking temperature. Press the numbered pads for desired cooking time. Press the **START/TOUCH-ON** pad to begin convection cooking.

**Manual Broiling:**

The Manual Broiling temperature is automatically preset to 450° F. Only the cooking time can be adjusted.

To use the broiler press the **BROIL** pad. Enter amount of cooking time. Press the **START/TOUCH-ON** pad to begin preheating the oven. Four beeps will signal the end of the preheat cycle. Food can now be placed into the oven.



### **CompuBroil:**

The CompuBroil cooking method has programs preset for common foods like hamburgers, steaks, chicken and fish. Temperature and time are preset depending on the food quantity. The amount of cooking time can be adjusted to fit particular needs. The **POWER LEVEL** pad will vary the preset cooking time. **Press once for more time and twice for less time.**

To use the CompuBroil feature press the **COMPUBROIL** pad. Select the food number from the food library next to the CompuBroil pad. Enter the number of pieces being broiled. Press the **START/TOUCH-ON** pad to begin the preheat cycle. A series of four beeps signal the end of preheat cycle.

### **Automatic Mix Cooking:**

This method combines both the convection oven and microwave at the same time. While in this mode the microwave will use 30% power on **HIGH/MIX** and 10% power on **LO/MIX**. The convection temperature can be changed from 100° F to 450° F. The default convection temperature is 325° F for both **HIGH/MIX** and **LO/MIX**.

To use this feature select either **HIGH/MIX** or **LOW/MIX**. Use the number pads to enter cooking time. Press the **START/TOUCH-ON** pad to begin the mixed cooking cycle.

### **CompuRoast or CompuBake:**

CompuRoast and CompuBake can be used for food items ranging from pastries and cakes to roasts, chicken and pork. The temperature is preset for both functions. Only the cook times can be tailored for individual preference by entering into either the CompuRoast or the CompuBake mode. Press the **POWER LEVEL** pad once for more cooking time and twice for less cooking time. To use either function press the desired pad and enter the food type from list next to the mode used. Enter the food type being cooked by using the number pad. To use CompuBake press the **START/TOUCH-ON** pad to begin preheat cycle. To use CompuRoast enter the weight of item using the number pads. Press the **START/TOUCH-ON** pad to begin the preheat cycle. Four beeps will signal the end of the preheat cycle and the oven is now ready.

---

### **Tips**

- Check the type of cookware being used to see if it is microwave or oven safe depending on the type of cooking being done.
- Gold paint or glaze may contain a trace amount of gold which is electrically conductive and not compatible for microwave. Hand-painted china commonly contains traces of metal.
- To test utensil for microwave compatibility place it in the microwave with an 8 oz. plastic cup of water. Set the microwave at full power for one minute. Carefully feel the utensil. The entire utensil should be cool to the touch.
- Cover food with a paper towel or upside-down plate to help keep food spattering to a minimum. Place a paper towel on the turntable to keep

clean-up at a minimum. Use paper towels with microwave use only.

- Clean all spills or splatters before they dry.
- Food odors may linger inside oven. To help eliminate odors combine the juice and the peel from one lemon, several whole cloves and 8 oz. of water into a two cup bowl. Place in oven on high power, bring to a boil for several minutes. Let cool in the oven for several minutes.
- Some food wrappers may be foil lined. Check the wrapping carefully before cooking or heating. Small amounts of foil are acceptable if not wrinkled or near the sides of the microwave.
- If the microwave screen is not lit plug another electrical appliance into the same outlet the microwave was plugged in to verify AC power is present. If the test item works, contact an appliance repair facility to have the microwave checked.

The exterior of the oven is plastic and metal. The interior is metal. Do not use scouring pads, harsh or abrasive cleansers, chemical cleaners or petroleum based thinners as these can damage the finish. Use mild soap and water with a damp cloth or paper towel to remove most stains or spills. When cleaning the touch pad, open the door to prevent accidental operation. Use mild soap and water with a soft cloth. Avoid using excess amounts of water on the touch pad. The turntable plate and oven racks are dishwasher safe.

## Care & Cleaning

### Grease Filters:

Do not operate the oven without the grease filters in place. This can damage the microwave. Grease filters should be cleaned at least once a month. To remove the filters, use the pull tab to slide the filter to the end of the opening and tip down. Soak the filters in the sink or in a dishpan filled with hot water and detergent.

- Do not use ammonia or other alkali based products. They may darken the filter material.
- Agitate the filter. Use a scrub brush to remove caked on grease.
- Rinse the filter thoroughly and shake it dry. Place the filter back into the opening, tip it upward and slide it to the end of the opening. Lock it in place. Be careful not to kink or warp the filter upon installation.

Cooktop burners use 12 Volt DC electronic ignitor to light burners. House battery cut-off switch must be ON to supply power to ignition module. To conserve LP-Gas energy preheat the pans only when recommended and shorten the cooking time by using the least amount of water possible. When cooking, heat the food on a higher heat setting, then turn the heat down to finish cooking.

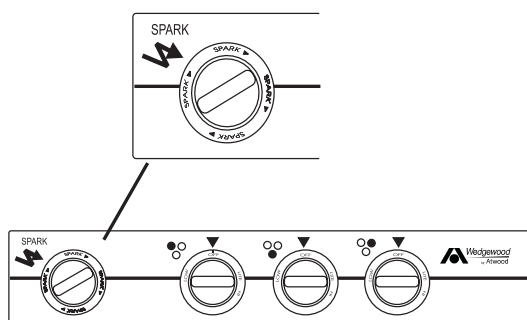

## COOKTOP

**To Light the Burners:**

1. Make sure the LP-Gas is turned ON.
2. Turn the knob counterclockwise to the ignite position.
3. When ignition has occurred, continue counterclockwise rotation to set flame to the desired setting.



**WARNING: If you smell gas extinguish all open flames and turn off the main gas supply. Liquid propane is highly volatile, highly explosive and extremely dangerous. Explosion, fire, property damage, injury or death can result.**

Propane is a “heavy” gas and will lay on the floor and “hide” in corners. Open all windows and doors. **Do not touch any electrical switches. They may cause a spark which can ignite.** Contact a qualified service center to have the problem correctly diagnosed and repaired before resuming operation.

---

**Tips**

1. A yellow flame is an indication of incorrect fuel/air ratio. Lowered BTU output and carbon build up can occur.
2. When cooking at an altitude above 5,000 feet, the flame may change appearance and the flame BTU output will be lowered. Allow extra cooking time.
3. Do not allow the tips of the flame to extend beyond pan or pot edge. When this occurs heat is wasted and possibility of injury increases.
4. To help keep the underside of the cooktop clean, remove the cooktop cover. Carefully place strips of aluminum foil on the cooktop floor pan and under burners. Do not restrict air flow of mixture tubes.

---

**Care & Cleaning**

Regular cleaning with a soft cloth and a warm detergent solution is generally enough to keep the cooktop clean. Wash, rinse and dry with a soft cloth. Thoroughly clean the cooktop when it is cool. To clean splatters or spills use a dry cloth or paper towel while the surface is warm to the touch. Cleaning will be more difficult if spills bake on to the surface. Glass cleaner sprayed on a paper towel should be used for the cooktop surface. Do not spray glass cleaner directly on the surface. DO NOT use abrasive cleaners or steel wool. Harsh cleansers like bleach, ammonia and oven cleaner should NEVER be used. The surface burner grate and caps should be cleaned using the same guidelines as the cooktop surface. Use oven cleaner in oven. Follow directions for any oven cleaner used.

**AIR CONDITIONER  
ROOF**

The motorhome is equipped with two 13,500 BTU roof air conditioners. The roof air conditioners operate from 120 Volts AC only, either by shore power or the generator. Operations are controlled by the 12 Volt DC comfort control. The electronics in the comfort control use a type of telephone patch cord to send a low voltage signal to the roof air conditioner's circuit board. The circuit board controls the desired roof air functions and LP-Gas furnace operation. The refrigeration process in the roof air, primarily the same as the dash air conditioner or a household type refrigerator, functions as an enclosed system. The refrigeration process repeats in a cycle. The refrigerant is drawn into the compressor. The high pressure vapor is sent to a condenser where the heat is expelled into the atmosphere. The vapor leaves the condenser as a high pressure liquid. This liquid is forced into a metered capillary tube and then into the evaporator or low side pressure. The refrigerant changes from liquid form to vapor as the heat is extracted. The vapor is drawn back into the compressor to start the cycle again. When operating the roof air in the heat pump mode, the refrigerant flow is reversed blowing the heated air into the interior of the motorhome.



**NOTE: Air conditioning systems will freeze the moisture in the air depending on the humidity content. Under high humidity conditions it is recommended to set the blower fan to High speed.**

The heat pump mode offers heat by using the air conditioner as a heat source. The air conditioning principal is reversed, supplying heated air to the ceiling registers instead of refrigerated air. There are ambient temperature limitations of the heat pump mode.

**Heat Pump**

**NOTE: The roof air conditioner will not operate in Heat Pump mode with ambient temperatures at or below 24° Fahrenheit.**

If the heat pump mode is selected at or below 24° Fahrenheit, or if operating in Heat Pump mode and temperature drops to 24° Fahrenheit, the air conditioner will stop Heat Pump operation and **Aux Heat** will be displayed. The furnace will be selected as the auxiliary heat source and will begin operation. The furnace will remain the primary heat source until ambient temperature rises above 42° Fahrenheit. When ambient temperature is between 24-42° Fahrenheit, a defrost cycle is initiated approximately every 40 minutes of compressor operation. The blower motor will stop for five minutes and Defrost will be displayed. After the defrost cycle the Heat Pump operation will resume.

## Operation

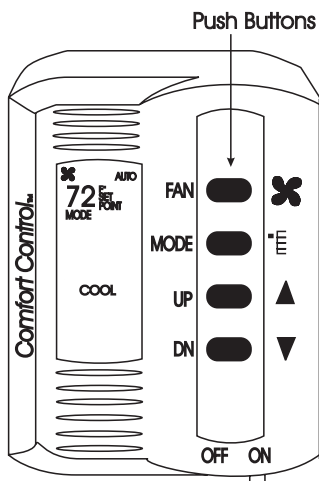

Comfort Control in air conditioner mode.

The roof air conditioner will operate only when the following needs have been met:

- 120 Volts AC from either shore power or the generator is supplied.
- House batteries are charged.

### Thermostat Operation In Air Conditioner Mode:

- Slide ON/OFF switch to ON position.
- Press the **MODE** button repeatedly until Cool is displayed.
- Set desired fan speed by pressing the **FAN** button.
- Set desired cooling temperature by pressing the **UP** or **DOWN** buttons.



**NOTE: Compressor will engage two minutes after blower motor activation. This prevents accidental compressor activation against high pressure.**

### Heat Pump Operation:

- Slide ON/OFF switch to ON position.
- Press the **MODE** button repeatedly until Heat Pump is displayed.
- Set desired fan speed by pressing the **FAN** button.
- Set desired heating temperature by pressing the **UP** or **DOWN** buttons.

## Return Air Filters

The return air filters should be cleaned frequently. They are located on the motorhome ceiling inside the air intake vent covers. Never run the air conditioner without the return air filters in place as this may plug the evaporator core with dirt and substantially affect the performance of the air conditioner.

### To Clean:

- Remove the vent covers and filters.
- Wash the filters and covers in warm soapy water. Do not use solvents.
- Rinse the filters and cover thoroughly with fresh water and allow them to dry.
- Reinstall the filters and covers.

## FURNACE

The furnace and its related components are 12 Volt DC operated, using LP-Gas as the fuel source. Electronic circuitry (automatic ignition) is used to ignite the burner. The furnace uses outside air for the burner combustion and exhaust is expelled through the outside vent. Inside air is drawn into the furnace and blown across the internal heat exchanger. Heated air is then discharged through ducted hoses which can be run throughout the motorhome. A warm air discharge is incorporated to heat the motorhome's holding tanks.

The furnace operates in the following manner: The wall thermostat sends a signal to the front roof air conditioner circuit board, which closes a relay. Closing a relay sends an electrical signal to the furnace to begin the ignition cycle. There is a small time delay before the blower motor begins. Once the blower motor attains a predetermined speed it will close the air prover or sail switch. The sail switch, which is now closed, sends the electrical signal through a high temperature protection switch, then to the automatic ignition circuit board. After the thermostat is satisfied, the gas valve closes and extinguishes the burner. The blower motor stops about two or three minutes after cool down.

**The furnace will operate when the following conditions have been met:**

1. The LP-Gas valve on the LP tank is open and the LP-Gas valve at the furnace is on.
2. The house batteries in the motorhome are charged.



**WARNING: IF YOU SMELL GAS extinguish all open flames and turn off the main gas supply. Liquid propane is a highly volatile, extremely dangerous gas. It can explode or ignite, which may result in property damage, injury or death. Propane is “heavy” and can “float” on the floor or “hide” in corners. Open all windows and doors. Do not touch electrical switches. They may spark, which can ignite. Keep all open flames, spark producing devices and smoking material out of the area. Contact a qualified service center to have the problem correctly diagnosed and repaired before resuming operation.**



**CAUTION: Do not store any items or materials in the furnace area. Restricted air flow may hamper furnace operation leading to failure and/or fire hazard.**



**NOTE: The automatic ignition circuit board will attempt to light the burner three times before the ignition board will go into “lock-out.” If the burner does not light, the furnace blower motor will continue to run and the wall thermostat will have to be cycled off.**

- Slide **ON/OFF** switch to **ON** position.
- Select the furnace mode on the Comfort Control using the **MODE** button.
- Select the **AUTO** speed with the Fan button.
- Select the desired temperature with the arrow **UP** and **DOWN** buttons.

***Using the Furnace***



**NOTE: When washing the exterior of the motorhome, avoid a direct stream of water into the outside furnace vents. This can cause damage to the furnace.**

### **Tips**

- After storage the furnace may produce a musty smell during the first couple of cycles.
- Operating the furnace at an altitude above 5,000 feet reduces the BTU output due to air/fuel ratio.
- The furnace will periodically need to be serviced by a qualified technician. If the furnace exhibits unusual symptoms or noises, or has an unusual odor when operating, have the furnace checked or serviced.
- It is advisable to use the furnace to heat the inside of the motorhome during transit. Outside temperature can vary to extreme cold. The dash heater may not provide adequate heat to the interior.

---

### **If Furnace Fails to Light**

If the furnace fails to light make sure the LP-Gas supply valves are open and the LP-Gas switch is turned on. The furnace will not light if the blower motor is not spinning to its specified speed. This may be due to a low house battery charge condition. Hook-up to shore power and start the generator or main engine to charge the batteries.



**WARNING: If you smell gas and the blower motor is spinning do not attempt additional furnace operation as this may result in an explosion, fire or personal injury. Contact a qualified technician.**

---

### **BATHROOM EXHAUST FANS**

Exhaust fan is powered by 12 Volt DC. Always close dome lid when motorhome is stored or unattended for an extended period of time. High winds and moisture leakage could cause serious damage to motorhome. Fan is for ventilation only, it will not cool motorhome.

- To open or close vents turn crank handle.
- To operate power air vent crank open vent and push in power button.
- To close power air vent push in power button to stop fan and close vent.

---

### **KITCHEN EXHAUST FANS**

Kitchen fan will either pull air in or extract air from inside motorhome. There are 3 controls located in ceiling attic vent. Knurled knob opens vent. Round knob controls fan speed settings. IN/OUT switch controls air flow to inside or outside of motorhome. Fan will run only when cover is open at least 3 inches.

- To operate open vent and turn fan ON to desired speed.
- To change direction of fan turn fan OFF, wait for blades to stop moving, push IN/OUT switch to desired position and turn fan ON to desired speed.
- If your motorhome has a thermostat set it at the desired temperature for ON/OFF fan operation.



**WATER HEATER**

The water heater in the motorhome will heat water using two different methods. The first method is 120 Volt AC, supplied either by shore power or the on board generator. The second method is LP-Gas. The 120 Volt AC uses a heating element like those found in a house style water heater. The 120 Volt AC method is efficient if shore power is available. The LP-Gas incorporates the use of an automatic ignition circuit board operated by 12 Volt DC. The water temperature is controlled by two thermostats: One for the 120 Volt and the other for the LP-Gas. The temperature is preset by the water heater manufacturer. Water is pumped into the bottom of the water heater tank where it is heated and discharged out of the top of the tank upon usage. For easy winterization the water heater is equipped with a temperature and pressure safety relief valve and a by-pass valve. The water heater has an aluminum clad tank. An anode is not necessary.



**NOTE:** The automatic ignition circuit board will make three attempts to light the burner. If the burner does not light by the third attempt the ignition circuit board will go into “lock-out.” Cycling the on/off switch will reset the ignition board.



**NOTE:** Do not operate the water heater by either function without water in the water heater tank to prevent damage to the thermostats and the electric heating element.

Before using the water heater purge all trapped air from the water system. To purge the air and pressurize the system fill the fresh water tank by using the on board water pump or hooking up to city water. Check the tank for any obvious water leaks. Once the system is pressurized turn the hot and cold valves on for each water faucet, one at a time, inside and outside of the motorhome. Run each faucet until a steady stream of water with no air bubbles or air pockets are present. The water heater does not need to be operating while this is being done.

***Before Using the  
Water Heater***



**WARNING:** IF YOU SMELL GAS extinguish all open flames and turn off the main gas supply. Liquid propane is highly volatile, highly explosive and extremely dangerous. Explosion, fire, property damage, injury or death can result. Propane is a “heavy” gas and will lay on the floor and “hide” in corners. Open all windows and doors. Do not touch any electrical switches. They may cause a spark which can ignite. Evacuate the motorhome and shut off the LP valve. Contact a qualified service center to have the problem correctly diagnosed and repaired before resuming operation.



**Tips**

The water heater will operate when the following conditions have been met:

- 120 Volt AC has been supplied either from shore power or the generator.
- The LP-Gas valve on the LP tank is open.
- The house batteries are charged.

---

**Water Heater - Using LP Gas**

- Make sure the LP-Gas is turned on.
- Turn the water heater switch to the ON position. The water heater will make an audible "roar" from the burner when ignited. The indicator light will illuminate briefly then go out when the water heater is lit. The indicator light will glow steady when the ignition cycle has gone into "lock-out."



**NOTE: It is not recommended to operate the water heater on LP-Gas while the motorhome is in transit.**

---

**Water Heater - Using 120 AC**

- Have either shore power or the generator supplying AC voltage.
- Turn on the water heater switch.
- Both gas and electric may be used at the same time. This will speed up the process of heating water for large volume usage.

---

**Tips**

- Turn off water heater when not in use to conserve LP-Gas.
- The water heater tank capacity is six gallons. When running the shower, conserve the heated water by shutting the shower water off when not in immediate use.
- Use caution when adapted to 30 amp shore service. When the water heater element is in operation it will use approximately 12 amps. Appliances may need to be operated in sequence to avoid tripping a breaker.
- The temperature and pressure (T & P) safety relief valve on the outside of the water heater is set to open at 210° F or 150 psi. When water temperature and pressure reach these settings the valve may drip until the pressure has dropped. Avoid opening the T & P valve manually as it may continue to leak. The valves can be purchased from most hardware stores.



**WARNING: Before beginning any service or work on the water heater make sure the LP-Gas is turned off, the 120 Volt AC source has been disconnected and the 12 Volt DC source has been disconnected. Failure to do so can result in explosion, fire or injury.**

- If water heater fails to light check the outside burner tube for obstructions. Spiders may make nests in the burner tube.
- If the indicator light on the monitor panel does not light and the water heater does not light, check for a blown fuse in the house distribution panel.

### **Troubleshooting - LP-Gas Operation**

- If the 120 Volt piloted switch does not light check the AC source, breaker, shore cord connection or transfer switch.

### **Troubleshooting - LP-Gas Operation**

If the motorhome was not ordered with an optional washer-dryer, it will have a washer-dryer preparation package installed from the factory. The washer-dryer “prep” package includes the following items:

### **WASHER/DRYER (Prepared)**

- Color coded water supply lines: red line for hot, blue line for cold.
- An 1½” waste water drain line with a threaded cap, a P-trap and an automatic vent cap. This will drain the waste water into the grey water holding tank.
- A designated 120 Volt AC receptacle for a washer-dryer is provided.



**NOTE: Sidewall dryer vents are not part of the prep package. If a sidewall vent is to be installed be sure it is properly sealed to the sidewall.**



**If a washer-dryer is to be installed at a later date, follow all the manufacturer’s installation instructions.**

Listed here are further instructions which should be adhered to for safe and reliable operation:

- Do not connect the clothes dryer exhaust duct to any other duct, vent or chimney.
- Do not terminate the exhaust duct beneath the motorhome.
- Use proper length fasteners when attaching exhaust vent to exterior sidewall. Stainless steel fasteners are best suited for this as they will not rust.
- If the cabinet or closet in which a washer-dryer is installed does not have vented/louvered doors, the manufacturer’s installation instructions may require installation of vented doors or vents to be installed in the doors. This is for sufficient circulation of drying air.

This appliance is an automatic washer with a capacity of up to 10 lbs. (4.5Kg) of dry clothing. It is front loading with an extra large door opening for easier access. It has five wash cycles in addition to extra rinse and extra spin cycles.

## WASHER-DRYER (OPTIONAL)

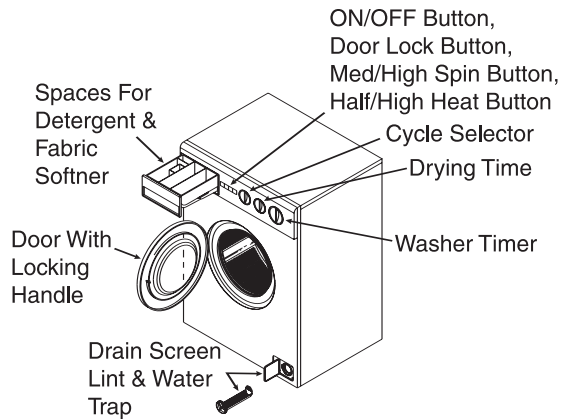

- The Washer-Dryer operates on 120 VAC.
- To operate the Washer-Dryer you will need to be plugged into shore power or have the generator running.
- The Washer-Dryer can be operated while driving down the road. The generator will need to be running and the water pump will need to be on. Make sure the grey tank will have enough room for the rinse cycle.
- The Washer-Dryer will use approximately 16 gallons of water per load.

### Operating Instructions

Before using the washer for the first time wipe the inside and outside with a damp cloth to remove any travel dust that has accumulated. Operating a rinse cycle to rinse out the washer is recommended. Front load, horizontal axis washing machines require less detergent. Soap suds line should not exceed the halfway point of the glass door.

#### To begin a wash load:

- Sort and pre-treat clothes.
- Add the measured amount of detergent suggested by the package directions (maximum two tablespoons).
- Load the clothes loosely into the washer. Close the washer door.
- Turn the cycle selector knob to the desired temperature setting.
- Decide which washing cycle you wish to use. Turn the timer knob clockwise to the desired wash setting.
- Select High or Medium spin (only for regular washing).
- Press the pushbutton **ON**.
- After the cycle is complete, wait two minutes for the door lock to release before attempting to open the door.



**WARNING: Do not wash or dry articles that have previously been cleaned, washed, soaked or spotted with gasoline, dry cleaning solvents or other flammable or explosive substances. Do not add these substances to the wash water as they produce vapors that could ignite or explode. Do not use dryer to dry articles containing foam rubber or similar textured, rubber-like materials. Clean the lint screen after each use (if applicable), located in the top left corner on the back of the washer. Keep the area around the exhaust opening and adjacent areas free from lint, dust and dirt accumulation.**

**Cleaning the  
Drain Screen**

The removable drain screen, which protects the pump from lint and foreign matter, needs to be cleaned periodically. The frequency in which it is cleaned depends upon the type of clothes that are washed. Cotton articles produce more lint than nylon articles. Under no circumstance should the drain screen be removed while the machine is full of water. To clean the drain screen on an empty machine open the service door by pressing on the left hand side. Place a cloth or shallow tray under the drain screen housing to catch any remaining water that may drip out. It may be helpful to first set the machine to spin, then remove the drain screen. This procedure reduces the amount of water released. Turn the drain screen counterclockwise and pull the drain screen out. Clean the screen to remove any dirt and lint. To replace the screen, slide it back into the housing and turn it clockwise to secure. Close the service door.



**NOTE: Check for water leaks before using the washer after removing and replacing the drain screen.**

To winterize your Washer-Dryer follow the instructions below to avoid damage to your unit due to freezing:

1. With the unit off, remove the wash filter to allow the water remaining (in the pump and drain hose) to be evacuated. Replace the filter.
2. Close the inlet shut-off valve located at the manabloc water system.
3. Open the low point drains to drain all the water.
4. In cold climates air should be used to blow out the system.
5. Install the water pressure regulator on a short water hose. Connect it to the water system. Use a air hose connector on the female end as this reduces pressure. Make sure one or more faucets are open.

**Winterizing the  
Washer-Dryer**

**If antifreeze is being used in the system follow these instructions:**

1. When putting antifreeze into the water system of your motorhome, set the washer to a warm/warm fill setting and allow water to flow into the unit until the antifreeze is detected.
2. Slowly advance the timer to a rinse cycle and allow the water to flow for 10 seconds. Advance the unit to a spin cycle to remove the majority of the water from the unit.
3. With the unit off, remove the wash filter from the unit. This will allow the water remaining in the pump and drain hose to be evacuated. Replace the filter.
4. Any water remaining in the unit should contain antifreeze and be protected from freezing.



**NOTE: When placing the unit back into service allow the unit to operate for one complete cycle before doing laundry to ensure all antifreeze has been purged from the unit.**

## **Cleaning the Washer-Dryer**

As you use the Washer-Dryer occasionally wipe the exterior of the cabinet with a damp cloth or sponge. Wipe dry with a soft cloth. Do not use polish on plastic trim. Clean the interior with one cup of chlorine bleach mixed with two cups of granular detergent. Run the washer through a complete cycle using the hot water. Repeat the process if necessary. Remove hard water deposits using only cleaners labeled as washer safe. Wipe the inside of the Washer-Dryer door with a soft cloth to remove any moisture. Periodically apply a thin coat of paste wax to the inner door, especially to the area which is immediately next to the door window. This will protect the door finish from laundry spills and discoloration.



**NOTE: Should the Washer-Dryer need removal for service, care should be taken as the Washer-Dryer weighs approximately 185 lbs. Proper accommodations should be made to avoid risk of injury.**

**NOTES**

# Diplomat

## SECTION 5 EQUIPMENT

<b>INTRODUCTION • 115</b>	
<b>ENTRY STEP • 115</b>	
<i>Operation • 115</i>	
<i>Tips • 116</i>	
<i>Maintenance &amp; Lubrication • 116</i>	
<b>STEP WELL COVER • 117</b>	
<i>Front Door Models Only • 117</i>	
<i>Adjustments • 117</i>	
<b>ENTRY DOOR • 117</b>	
<i>Latch Adjustment • 117</i>	
<b>SCREEN DOOR • 118</b>	
<i>Removing Screen • 118</i>	
<i>Changing the Glass • 118</i>	
<i>Adjusting the Glass • 118</i>	
<b>SLIDE-OUT ROOM • 119</b>	
<i>Extending Room • 119</i>	
<i>Retracting Room • 120</i>	
<i>Awning Slide-out • 120</i>	
<b>MANUAL OVERRIDE • 121</b>	
<i>Galley Slide-out • 121</i>	
<i>Manual Override-Bedroom Slide-out • 122</i>	
<i>Preventative Maintenance • 122</i>	
<i>Front Television Lock-Out • 123</i>	
<b>ENTERTAINMENT CENTER - HOME • 123</b>	
<i>Television Antenna • 123</i>	
<i>Television Hookups (TV Cable, Computer &amp; Telephone) • 125</i>	
<b>VIDEO SELECTOR BOX • 125</b>	
<i>Front Television • 126</i>	
<i>VCR &amp; Bedroom Television • 127</i>	
<b>CITIZEN BAND RADIO • 127</b>	
	<b>AWNINGS • 127</b>
	<i>Front door • 127</i>
	<i>Care &amp; Maintenance • 128</i>
	<i>Awning Patio • 128</i>
	<b>AWNING AUTOMATIC (Optional) • 131</b>
	<b>SUNVISOR (Optional) • 133</b>
	<i>Sofa to Sleeper • 133</i>
	<i>Sleeper to Sofa • 133</i>
	<b>DINETTE BED CONVERSION (Optional) • 133</b>
	<b>TO EXTEND FIXED DINETTE • 134</b>
	<b>STORAGE UNDER BED • 134</b>







Section Five covers the basic operation and care of various types of equipment found in the motorhome, most of which are provided for entertainment and comfort. More detailed information about specific equipment may be found in that particular manufacturer's manual. Optional equipment will also be discussed in this section which may not apply to all motorhomes.



**Detailed information with CAUTION or WARNING instructions for the various electronics, other than what is provided in this section, can be found in the manufacturer's manual.**

## **ENTRY STEP - Operation**

The entry step features amber lighting under the step, automatic retraction with the ignition key in the RUN position and a last out feature. Located to the left, just inside the entry door, is the step switch.

### **Operating the Entry Step:**

1. With the entrance door open turn the step switch on.
2. Close the door. The step should retract and lock in the UP position. The step light will remain on.
3. Open the door. The step should extend and lock in the "down" position with the under step light on. The step will retract when the door is closed.
4. The step is equipped with a power switch. When the switch is turned off, the step should remain in the extended position with the door closed and the under step light off. Close the door and turn on the ignition switch. The step will retract for travel.

To hold the entry step in the retracted position proceed with the following:

- Turn the engine ignition switch OFF.
  - Wait 15 seconds and then turn the power step switch from **OFF** to **ON**, then back **OFF** again. The step will stay retracted until the step switch is turned **ON**, or the ignition switch is turned on. The retracted position is useful for high curbs or on boat ferries.
5. With the power switch **OFF**, the step extended, the entrance door closed and the ignition turned **ON** the ignition override system will go into effect and the step will automatically retract.
  6. Turn the ignition **OFF** and open the door. The step will extend and lock in the "down" position. This is the "last out" feature. When the ignition is **ON** the step will always activate with the door movement, regardless of the power switch position.

**Tips**

**If the step fails to operate:**

- Make sure the step switch is **ON**.
- Check the main power supply for the step. A 20 amp auto reset 12 Volt DC circuit breaker is located on the rear run plate.
- A magnetic door jam switch is used to control step operation. Use a separate magnet to apply a “trigger” to the door jam switch. Rotate test magnet to align polarity field.
- A five amp ATO blade fuse is used to illuminate the STEP OUT dash warning light. The fuse is located on the front run plate.



**WARNING: If the motorhome is driven with the step in the extended position there is the possibility of causing major damage to both the step and the motorhome.**

**Maintenance & Lubrication**

Clean all mud, salt and road grime from the step before lubricating. Lubricate all moving parts (bearings, pivot points, slides, clevis pin, and the drive linkage ball) every 30 days with a good quality heat and moisture resistant penetrating grease.

*Kwik Lube Spray Grease* is specially formulated to lubricate *Kwik Electric Steps* and it is also recommended for lubricating all moving parts. Refer to the picture.

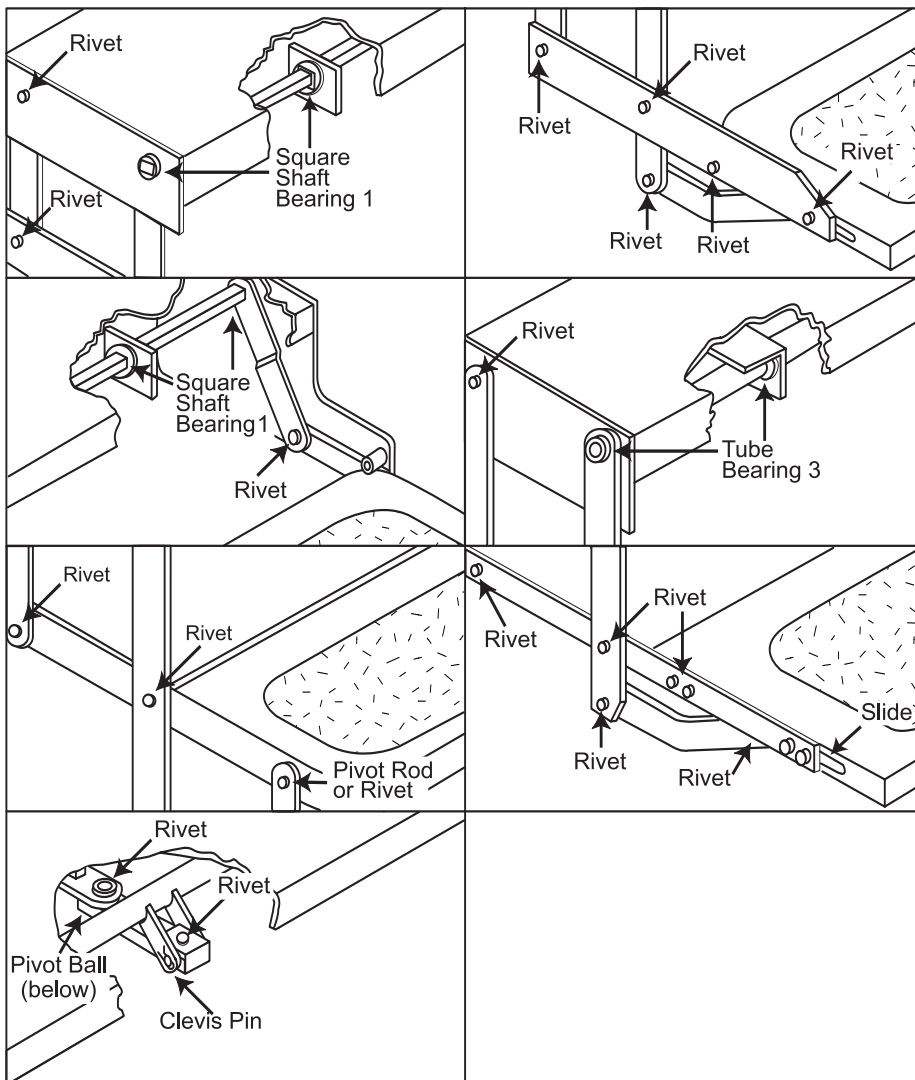

**NOTE: Silicone lubricates and WD-40 are not recommended as they have a tendency to evaporate and dry the mating surfaces which leaves them vulnerable to the elements.**

The motorhome is equipped with a sliding stepwell cover that is extended and retracted by the use of a dual action air cylinder. The air cylinder is controlled by an electrically operated air valve. The air cylinder is controlled by an electrically operated air valve. The air solenoid, known as a “MAC” valve, receives air pressure from the front air tank. The “MAC” valve will direct the air pressure to either side of the dual action air cylinder, moving the stepwell cover in or out. The stepwell cover will not operate without sufficient air pressure (approximately 60 psi).



**CAUTION:** The stepwell cover is under air pressure. When operating the stepwell cover be sure there are no pets, shoes or other obstructions in the stepwell area. Do not operate the stepwell cover while standing in the stepwell area.

## STEPWELL COVER (Front Door Models Only)

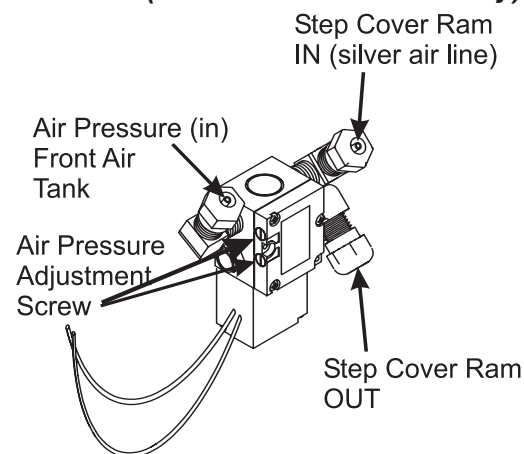

The “MAC” air valve is located in the front of the motorhome, behind the generator door mounted to the frame. The easiest way to identify the location is have someone operate the stepwell cover with the generator door open and listen for the release of air.

The “MAC” air valve has two adjustment screws. The adjustment screws regulate the air flow to either side of the air cylinder. Adjusting the screws will affect the speed in which the air cylinder moves in or out. Clockwise adjustment on the screw will decrease air flow. Counterclockwise adjustment on the screw will increase the air flow. For proper stepwell cover adjustment it is recommended that adjustments be performed by a qualified service person.

## Adjustments



**WARNING:** When adjusting the stepwell cover clear the stepwell area of obstructions, pets or persons. Do not adjust the stepwell cover while stepwell area is occupied.

The entry door is adjusted at the factory and tested for all operations. The door incorporates three separate seals to eliminate wind noise during travel. The door uses two separate locks for safety and security. One locking system is the door handle and the other is a dead bolt. The door handle incorporates a primary and secondary latching system. This is used to ensure secure and safe latching. There are adjustments which can be made to help maintain entry door performance.

## ENTRY DOOR Latch Adjustment

### Adjusting the Entry Door Latch:

- Determine which bolt needs adjustment.
- Slowly close the entry door observing the latch and strike bolt alignment. Do not attempt to latch if the alignment is off. If the alignment is correct,

- allow the latch to catch in the first (primary) position only.
- The latch should move to the second position with just slight pressure applied to the entry door. Upper and lower latches should be evenly timed. Press on the entry door to see if there is any further movement of the door.
  - The entry handle should operate with little effort to open the entry door. An excessive amount of pressure indicates the bolts are set too far back.
  - With a 5/8" inch box wrench or socket, loosen the movable strike bolt. Make all adjustments in small increments. Tighten the bolt firmly after making adjustments. The bolts should have slight up and down movement for vibration control in travel.
  - Test the operation of the dead bolt lock to ensure proper functions.
  - Silicone should be applied weekly to the entry door rubber gaskets to prevent squeaking while the motorhome is traveling. Use a one inch sponge paint brush, sprayed with silicone for easy application.



**CAUTION: When operating the entry door ensure the dead bolt latch is fully in the unlock position prior to closing the entry door. Failure to do so can result in damage to the dead bolt and/or entry door.**

---

## **SCREEN DOOR - Removing Screen**

### **Removable Screen**

The top half of the screen door is removable. This allows clear viewing through the entry door glass while traveling.

- To remove the top half of the screen door for travel rotate clips and remove the screen.
- To store the screen for travel use the clips provided on the bottom half of the screen door.

---

## **Screen Door - Changing the Glass**

### **Changing the Glass in the Screen Door:**

- The screen slider is plexi-glass, the slider can be bowed for removal and replacement.
- Replace with new plexiglas and reverse the procedure.

---

## **Screen Door - Adjusting the Glass**

### **Adjusting the Screen Door For Up and Down Location:**

- Loosen the chrome bolts on the hinge side of the screen door. Four on the top and four on the bottom.
- There are slots in the steel hinge to allow up and down movement.
- There are four allen type screws on the top hinge and four on the bottom hinge to adjust the screen door so it fits properly to the door. The hinge should fit tightly to the trim of the door, when the screen door is latched to the door and the door is open.
- Check to see that the pad on the inside of the door is not sitting on top of the aluminum trim of the door. If it is, it will hold the screen door away from the door and you will not have a proper seal. If the pad is too large, re-size the pad.

**To Extend the Slide-Out Room:**

- Move the driver seat forward before activating the slide-out room.
- Confirm that there is at least five feet of clearance outside the motorhome for the slide-out room to extend.
- Ensure the ignition key is in the **OFF** position.
- The park brake must be applied.
- The storage bay doors under the slide-out must be closed.
- Locate the two locking bar mechanisms on the top of the slide-out room inside the motorhome.
- Move the handles to the unlock position.

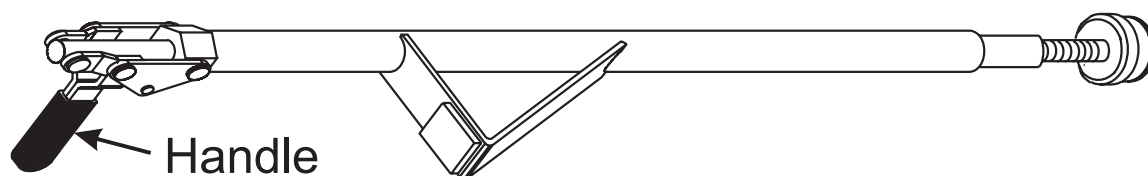
**SLIDE-OUT ROOM  
- Extending Room**

Unlock ↔ Lock

- Release the bar mechanisms and remove the bars from between the wall and the top of the slide-out room. Store the bars for reuse before the motorhome is in motion.
- Locate the slide-out room control switch located in the passenger side overhead compartment above the entry door.
- Press and hold the slide-out room switch in the **OUT** position. The slide-out room will slowly move to the **OUT** position. To continue the room movement push and hold the switch in.
- Release the slide-out switch when the room is fully extended (a change in motor sound indicates extension). The slide-out drive motor will not stop automatically, the switch must be released.
- Level the motorhome with the leveling system.



**WARNING:** Move the drivers seat forward before activating the slide-out room. Ensure there is five or more feet of clear space outside the slide box prior to extending the slide room. The outside area must be clear of any obstructions which may hinder the movement of the slide room. Ensure there is sufficient clearance inside the motorhome. Never move the motorhome with the slide-out extended.



**CAUTION:** Remove the LOCK'R bar before moving the slide-out room: damage can result if left in position. Monaco Coach Corporation is not responsible for damage resulting from operating the slide-out room with LOCK'R left in position .



**CAUTION:** Dirt and grit trapped under the slide could result in damage to the floor. Continuous operation of the slide-out could cause a drain on the house batteries and damage to the the slide motor from overheating.



**NOTE:** Slide-out room operation should be performed with a full air suspension system. It is not recommended to extend the slide room in snow, sleet, ice or freezing rain. There may be extensive damage resulting from the awning freezing up.

## Retracting Room

### To Retract the Slide-Out Room:

- Check for sufficient clearance inside the motorhome before retracting the slide-out room.
- Clean the floor, if applicable, to ensure there is no dirt or grit that could result in floor damage.
- Press and hold the switch in the **IN** position. The slide-out room will move slowly in. To stop the slide-out room before the room reaches the **IN** position, release the switch. To continue the room movement, push and hold the switch in. The motor will change tone when the slide-out room is fully retracted.
- Release the switch.
- After the slide-out room is all the way retracted, locate the two removable locking bar mechanisms. Place the bar mechanisms between the wall and the top edge of the slide-out room. The Lock'R has a built in spring to preset the tension. Move the handle to lock the position.



**NOTE:** Be sure you have sufficient clearance on the inside of the motorhome (drivers seat, etc.) before you retract the slide-out room. If your motorhome has ceramic tile floor, make sure the the floor is clean before you retract the slide-out room. Dirt or grit that is trapped under the slide-out room could scratch the floor. Never move the motorhome without having the slide-out room retracted.

## Awning - Slide-Out

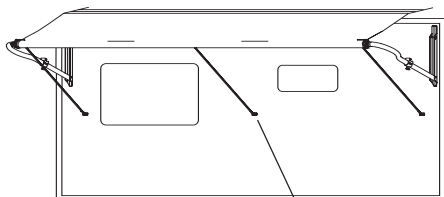

Awning at full extension.

The motorhome is equipped with a slide-out awning that will automatically roll out with the slide room when it is extended. When the slide room is extended, the awning can then be rolled out completely as a window awning. The slide-out awning has two devices to help prevent the awning from “billowing” while traveling. The first device is a pair of anti-billow studs, which are located above each end of the awning roller tube. If the awning catches wind and begins to billow, the awning metal wrap will contact the anti-billow stud levering downward and engaging with a plastic gear preventing further unraveling of the awning material. The second device uses two metal wind deflectors

which are positioned just below the awning. This helps prevent side winds from scooping under the awning and unwinding the awning material.



**CAUTION:** The slide room and slide-out awning should be retracted during heavy winds or rain. Rain can be driven up under the slide-out awning and into the motorhome. The slide-out awning should be retracted in high wind conditions as damage can occur to the awning or motorhome.



**NOTE:** At least five feet of clearance is needed between the side of the motorhome and any objects, such as trees or fences, to allow the slide room and slide-out awning to be fully extended.

To move the slide-out room manually retract the motorhome leveling jacks (see “Leveling Jacks”).

## MANUAL OVERRIDE - Galley Slide-out

1. Open outside storage compartment doors underneath slide-out room.
2. Remove plastic covers from top of compartments to gain access to drive shaft and drive mechanisms.
3. Move lever on motor counterclockwise to release motor brake and turn end of shaft next to gear box with wrench to move slide-out room.
4. Once the room is in apply pressure to the wrench so that the room is sealed. Return the brake lever to its normal position to lock the room in place. Install the transit bar.
5. Take the motorhome to an authorized dealer for service.



**NOTE:** The slide-out room is heavy and may require several persons to push it into the retracted position. When the slide-out room is in the fully retracted position tighten the T-Handles to hold the room in place.

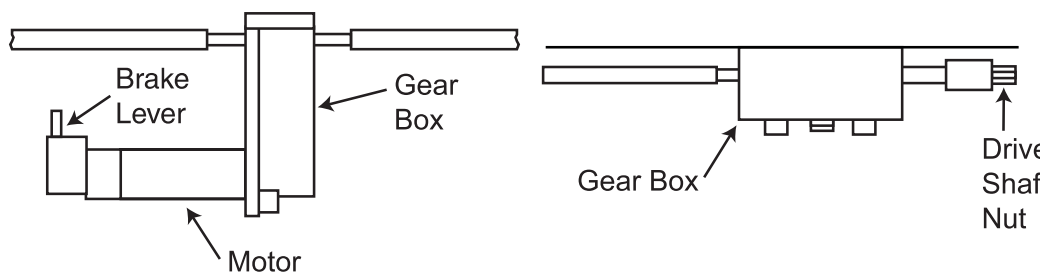



## Manual Override - Bedroom Slide-Out

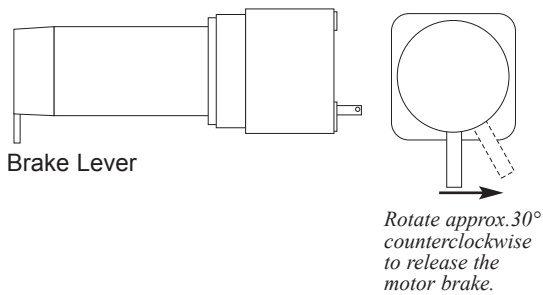

### Manually overriding the bedroom slide-out:

1. Disconnect the battery cables from the battery.
2. Lift up the mattress and baseboard to gain access to the slide-out mechanism.
3. If the bedroom slide-out motor has a lever on the back side, rotate the lever counterclockwise about 1/8 of a turn (looking from the rear of the motor) to release the brake that locks the room in place. If the motor does not have a lever, use a 1/2" wrench to remove the four motor mounting bolts. Remove the motor.
4. Use an appropriate wrench (a 3/4" wrench/ratchet or an adjustable wrench) on the override to move the room in or out. The override is located on the opposite side of the slide-out rail from the motor.
5. Once the room is in apply pressure to the wrench so that the room is sealed. Return the brake lever to its normal downward position to lock the room in place. Install the transit bar (if so equipped). If the motor does not have a brake lever apply pressure to the wrench so that the room is sealed and install the transit bar (if so equipped). If there is no motor lever and no transit bar, the motor must be mounted back onto the slide-out system to hold the room for transport. Because of this the room may not be sealed from the environment.
6. Take the motorhome to an authorized dealer for service.



**NOTE: The slide-out room is heavy and may require several persons to push it into the retracted position. When the slide-out room is in the fully retracted position tighten the T-Handles to hold the room in place.**

## Preventative Maintenance

The slide-out system has been designed to require very little maintenance. To ensure the long life of the slide-out system read and follow these simple procedures:

- The roof of the slide-out should be checked for debris such as pine needles, dirt, leaves, sticks, etc. If the slide-out has been out for a period of time any debris left on the top may cause damage to the seals when being retracted. If debris is present wash with soap and water, then rinse.
- When the room is out visually inspect the inner slide rail assemblies. Check for excess build-up of dirt or other foreign material. Remove any debris that may be present.
- If the system squeaks or makes noise apply a coat of light weight oil to the drive shaft and roller areas. Remove any excess oil so dirt and debris do not build-up. Do not use grease.





**CAUTION:** Do not work on the slide-out system unless the battery is disconnected.



**NOTE:** Do not leave the slide-out in the extended position during severe weather. Conditions such as high winds or heavy rain may cause damage to an extended slide-out.



**NOTE:** It is not recommended to extend the slide room in snow, sleet, ice or freezing rain. There may be extensive damage resulting from the awning freezing. In the event the slide-out room is extended in snow, sleet, ice or freezing rain conditions it is recommended you clear the awning and ensure free movement prior to retracting the slide room.

The motorhome is equipped with a remote control color television located above the pilot seat. The outlet for front TV is controlled by the ignition switch so that the front TV can only be viewed while the vehicle is at rest. The TV operates from 120 Volt AC power only which can be provided by shore power, the generator or the inverter. Viewing time of the front TV from the inverter depends on the state of charge of the house batteries and any additional 12 Volt DC lighting being used.

**ENTERTAINMENT  
CENTER - HOME**  
*Front Television  
Lock-Out*

The television antenna is a manual crank up style antenna with built in electronics which use 12 Volts DC to boost signal strength. Signals that are weak or fuzzy can be amplified by turning on the boost switch in the passenger front overhead cabinet. The antenna and booster work together to provide the best possible picture for most situations. Certain conditions occur when no amplification is needed and in fact may make the picture worse. The television station will send a signal that resembles the waves or rings of water from a rock thrown into a still pond. The radiating television signal can hit an object such as a mountain and come back. The result one sees in the television picture is a double image. The antenna will receive a signal from the initial pass, then receive an additional signal from the rebound resulting in a split or double image. In this case the picture may be improved by no amplification or even lowering the antenna.

**Television  
Antenna**



**NOTE:** Do not move the motorhome with antenna in the raised position, it can be damaged by tree limbs or wires.



**WARNING:** Before raising antenna make an outside visual inspection for any obstructions or overhead electrical wires. Damage to the antenna, severe shock, personal injury or death can occur.

**To Raise The Antenna:**

Rotate crank handle clockside to raise (approximately 14-1/2 turns). Pull down on outside directional wheel and rotate antenna until best picture is obtained. Directional wheel is spring loaded.

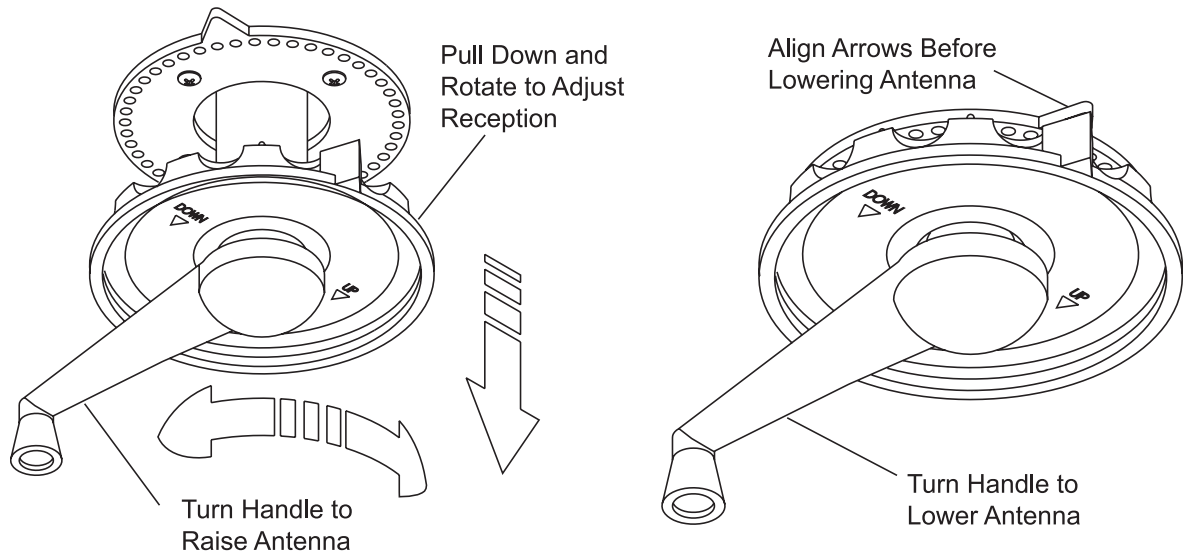

**WARNING: Do not raise a TV antenna near overhead electrical wires as contact may cause serious injury or death.**



**WARNING: The motorhome must not be moved with the antenna in a raised or partially raised position. Worm gear or worm breakage may result.**

**To Lower The Antenna:**

Pull down on the directional wheel and align arrows together. Rotate crank handle counter clockwise lowering antenna fully into the cradle. Make an outside visual inspection to ensure the antenna is properly stowed.

**Boost Operation:**

To boost the antenna signal to the TV or VCR use the boost switch. Turn this switch to the ON position. Turn the boost switch off when not in use.

The motorhome is equipped with cable TV and telephone hook-ups, located in the electrical service center. For convenience, there are auxiliary outlets located at the co-pilot seat and on the optional computer desk. This connection is set up for a phone or laptop computer to be used.

### Hook-ups - TV Cable, Computer & Telephone

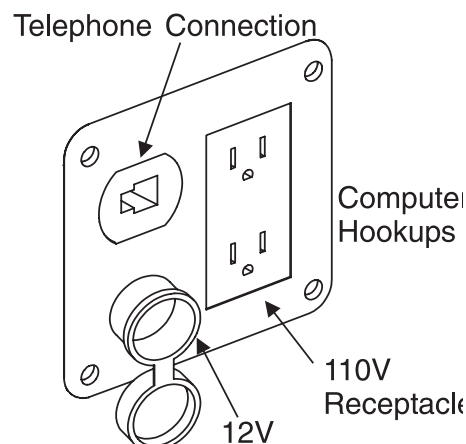

The motorhome is equipped with a video selector box located just above the VCR. The selector box receives video and audio signals from three different sources: the roof mounted antenna, shore cable (Auxiliary) or the VCR. The video selector box directs the signals to either the front or rear TV, and directs the signal from shore cable or the roof mounted antenna to the VCR. The selector box switches are divided into three groups: TV1 (front TV), TV2 (rear TV) and the VCR. Both the TV1 and TV2 button groups perform the same functions. Example: To watch the front TV (TV1) from the antenna depress the ANT button in the TV1 group. This will direct the signal from the antenna to the front TV.

### VIDEO SELECTOR BOX

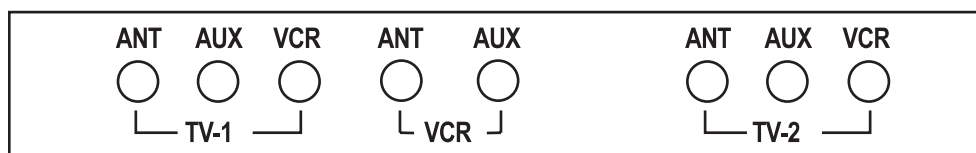

#### To Watch the FRONT TV:

- Using the antenna depress the ANT button in the TV1 group.
- Using the shore cable, depress the AUXILIARY button in the TV1 group.
- Using the VCR turn the TV to channel 3 and depress the VCR button in the TV1 group.

**To Watch the REAR TV:**

- Using the antenna depress the ANT button in the TV2 group.
- Using the shore cable depress the AUXILIARY button in the TV2 group.
- Using the VCR turn the TV to channel 3 and depress the VCR button in the TV2 group.



**NOTE: When watching TV by using the VCR, such as playing a tape, make sure the TV is turned to channel 3.**

**Using the VCR (Optional):**

With the antenna, depress the ANT button in the VCR group. With the shore cable, depress the AUXILIARY button in the VCR group.

1. If the picture is weak and the antenna boost is working, try moving the motorhome a few feet forward or backwards.
2. If it is weak or has no picture check the video selector box to make sure the proper mode button has been selected.
3. If the signal is still weak it may be a shorted or open coax. The coax cable is made up of two conductors: A center conductor which is usually copper, and the ground which is woven or braided aluminum. There is insulating material that separates the two conductors known as the die-electric. The ground and center conductor are to remain separate from one another. When installing a metal end onto the coax cable, use care so that none of the woven ground strands come in contact with the center conductor. A continuity tester is used to rest for a suspected bad coax wire run. Unscrew both ends of the suspected bad coax run and use the continuity tester to check between the center conductor and outside threaded ring. If continuity is present the coax is shorted. To test for an open connection of a particular coax run, touch ends of the coaxes ground or center conductor using the tester leads. Continuity should be present. For proper operation there should be continuity from one end to the other of both the ground and center conductor. No continuity should be between the ground and center conductor. Though damage does not usually occur from a shorted or open coax cable, picture quality is compromised.

---

**Front Television**

The motorhome is equipped with a remote control and color television. The TV operates from 120 volts AC power only, which can be provided by shore power or converter. Viewing time of the front TV from the converter depends on the state of charge of the batteries and any additional 12Volt DC lighting being used.

The VCR and bedroom television operate from 120 Volts AC only, which can be provided by shore power or converter. Use the instructions given in the video selector box section to use these components.

## VCR & Bedroom Television

Located under dash next to two pin dash accessory connector is a two pin connector labeled Citizens Band Radio. Red wire is at 12Volt DC and is fused at 2 amps through front distribution panel. White wire is connected to chassis frame.

## CITIZEN BAND RADIO

### To Extend The Awning

- Hook the pull strap look with awning pull rod.
- Pull strap until awning is at full extension. With level inner arms.
- Mate the slot of inner arm with hook on side of motorhome. Repeat procedure for other arm.
- Release strap slowly ensuring inner arms are secure. Slide the strap to rear of awning roll tube and tie to rear arm.
- Loosen locking knobs for both arms and extend arms so that canvas will clear door in the open position.

### To Retract Awning

- Loosen locking knobs for both arms. Lower arms to stop bolts. Tighten knobs.
- Untie the pull strap and slide strap to center of awning roll tube.
- Pull down on pull strap with a firm grip until tension is off the inner arms. Fold inner arms and attach them to the velcro.
- Carefully allow material to wind onto awning roll tube while holding strap in a neutral position. This will allow material to roll up evenly.
- Awning end caps should be against the rubber bumpers. If one end cap is off, pull down on awning pull strap while holding strap slightly to opposite side, allowing awning to roll back up into position.

free hand,

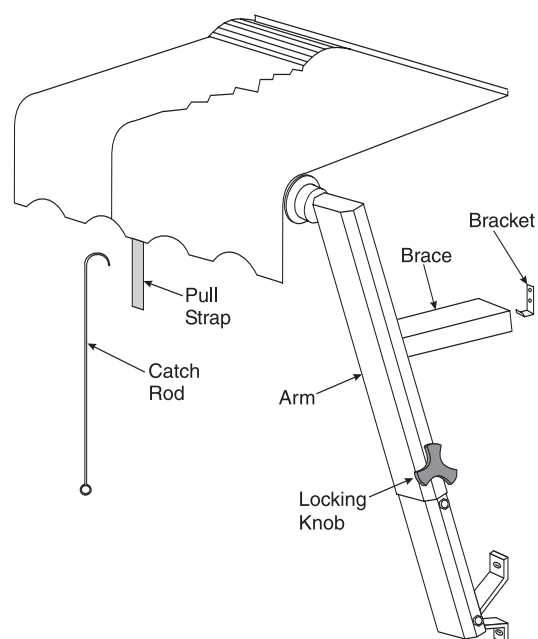

## AWNINGS - Front Door



**CAUTION: When the awning is at full extension do not allow the awning to snap back into the retracted position. Personal injury or damage to the awning or motorhome may occur.**

## Awning Care & Maintenance

### Care and Maintenance

Mildew will not form on the awning material itself, but it may form on the dust accumulated on the canopy. A quality vinyl cleaner, such as Carefree Awning Magic, will help keep your awning looking new. Be sure to follow the instructions on the container.



**NOTE: Allow the awning material to thoroughly dry before rolling the awning up. Metal surfaces should be cleaned with soapy water and thoroughly rinsed.**

### Awning - Patio

#### To Unlock the Awning:

1. Loosen the black locking knobs.
2. Lift the arm storage locks located on each upper arm to the unlock position. Slide the brake control, located on the front arm only, to the full up (unlock) position.

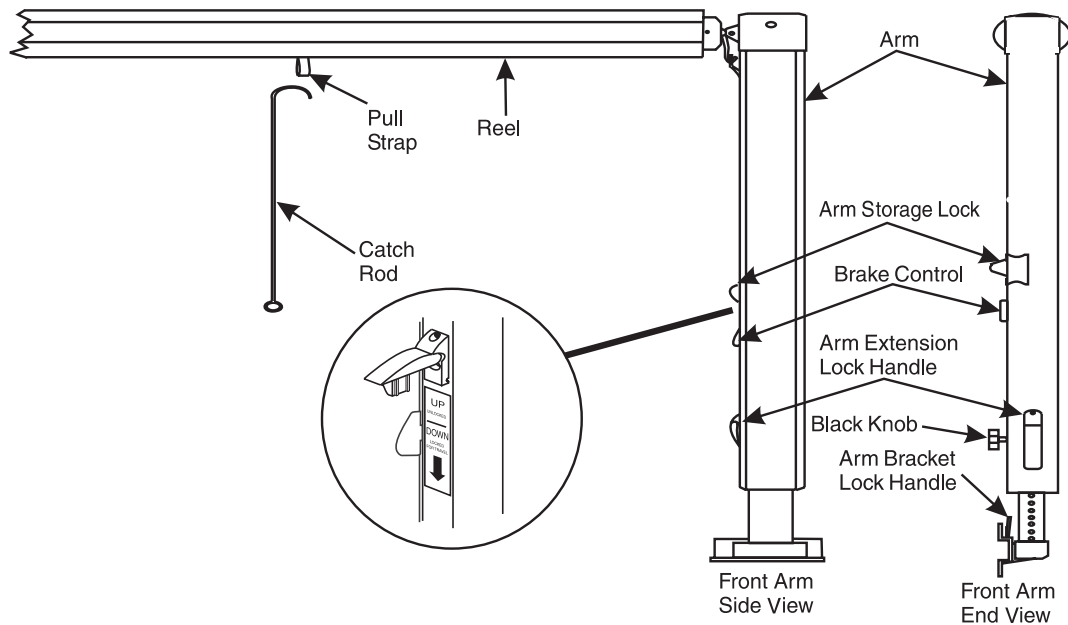

#### To Extend The Patio Awning

1. Hook the loop of the center strap with the pull wand and draw the awning away from the motorhome to the desired extension. Slide the center pull strap to one end of the awning and store it.
2. Slide the inner rafters to the top of each arm and push outward to the tension canopy. Tighten the black locking knobs.
3. Raise the arm extension lock handles and slide the awning upward. Lower the lock handles and move the awning arm upward or downward to lock the detent into the hole. First, raise the lock handles on the main side. Next, raise the lock handles to the entry door. Go do the other awning arm and do the same. Make sure the awning is straight.

### To Retract The Patio Awning

Retract the arms and lower the awning until the arms rest on the lower stop bolts and lock into position. Loosen the two black locking knobs. Release the locking tab on the end of the awning leg. Slide the pull strap to the center of the awning while holding on to the strap. Allow the awning to roll up to the stored position.

- Snap the arm storage locks into the down position.
- Verify that the brake control is in the locked or closed position.

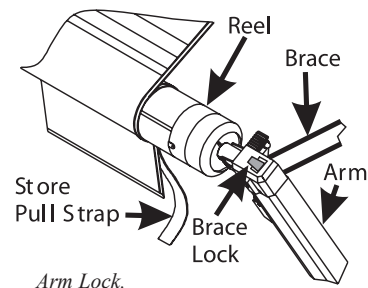

### Rain Release Setting:

After the awning has been extended, choose the rain release position to prevent water build up on the awning. To position the awning in the rain release setting lower one arm of the awning and leave the other arm in the normal position. This will create enough of a slope for adequate water run off.

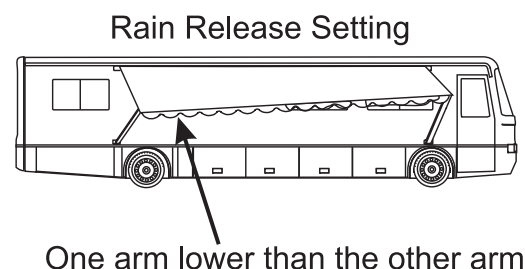

### Using The Carport Feature:

To safely use the carport feature:

1. Extend the braces and lock them into the end of the side arms. Tighten the black knobs.
2. Extend the awning as described under "To Extend Awning."
3. Unlatch the bottom of the rear arm by pushing in on the lock handle on the arm bracket. Swing the arm away from the motorhome to an upright position.
4. Raise the rear arm extension lock handle all the way up to the unlocked position. Extend the arm to position the awning at the desired height and lower the lock handle to lock the arms in place.
5. Drive the stakes through the bottom holes in the arm.
6. Repeat instructions 1 through 5 for the front arm extension lock handle.

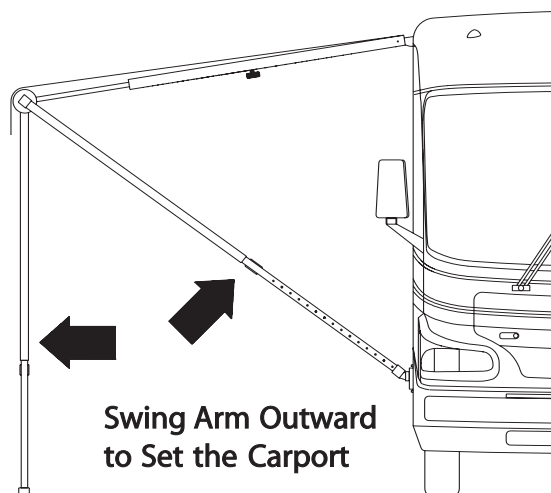

**NOTE: To move the awning out of the carport position reverse the above steps.**

### Securing The Awning For Travel:

Before traveling, check the following:

1. The awning is fully retracted against the sides of the motorhome.
2. The black locking knobs are tightened.



3. The storage locks are down and in the locked position.
4. The brake control is in the full down (locked) position and no red warning is showing.
5. The bottom of the front and rear arms are latched properly into the bottom brackets.
6. The catch rod is stored away.

**Care and Maintenance:**

- **Washing:** On a monthly basis, loosen hardened dirt and remove dust from the awning with a dry, medium bristle brush. Thoroughly rinse both the top and bottom with a hose. Wash both sides of the awning with a quality vinyl cleaner solution using an awning brush. This process can be made easier with awning maintenance products.

Saturate the fabric with the solution and leave it on for 15-20 minutes.

If necessary, reapply the solution to keep the fabric saturated. Rinse the awning thoroughly. Repeat, if necessary, until most of the stains disappear.

- **Water Leaks:** If leaking occurs after washing it generally results from insufficient rinsing. If water drips through the needle holes in the stitching use a commercial seam sealer which is available in canvas and trailer supply stores. Paraffin wax may also be applied to the top of the seams. As the awning “weathers” these holes will normally seal themselves.

It is normal for slight leakage to occur through the fabric where water is allowed to accumulate or pocket on the fabric. See “Storm Precautions” for information on the awning settings for proper water drainage. Sometimes soap or chemical residue, such as from active agents in insect fog or sprays, can “wet” the fabric so that it appears unable to repel water. Rinse the fabric thoroughly and test to see if it is water repellent after it dries. If leakage continues after repeating the washing and thoroughly rinsing, please contact Carefree Awning concerning further maintenance.

- **Storm Precautions:** The warranty does not cover damage caused by acts of God; therefore, steps should be taken to prevent damage from occurring due to wind, rain or storms. If you are leaving or retiring for the night, close the awning. This takes only a few seconds and it gives the best protection for the awning. If unable to close the awning, lower both ends of it as far as you can. This will create a sufficient slope for water run-off. One end may be lowered to sufficiently divert the water, if the awning is being monitored.



Water weighs 8.33 pounds per gallon. The awning was not made to withstand the 500 to 700 pounds that could accumulate. It is best not to subject the awning and the motorhome to the needless strain.

The Carefree One Touch automatic awning requires only “finger tip” operation. A key lock on the One Touch switch pad is provided to prevent accidental deployment of the awning while the motorhome is in motion. The key is removable in the lock or unlock position.

Gas filled struts keep the awning fabric tight at any extended position. The 12 Volt DC motor for the One Touch awning uses approximately 15 amps while in operation.

## AWNING - AUTOMATIC (Optional)



### To Extend the Awning:

- Verify all persons and objects are clear from the extend path of the awning and related hardware.
- Turn the One Touch key to the **ON** position.
- Depress and hold the momentary switch to **EXTEND**. Motor will automatically stop at full extension.
- Allow 14 seconds for awning to reach full extension.
- Extension distance or fabric tension is adjusted by toggling between **RETRACT** and **EXTEND**.
- Turn the One Touch key to the **OFF** position.



**CAUTION:** The patio awning requires nine feet of lateral clearance from the side of the motorhome. This distance will allow the awning to reach full extension. The One Touch patio awning was not designed with a carport feature or a rain release setting. The awning should be retracted if the motorhome is left unattended or high wind conditions exist. Otherwise, wind damage to the awning may occur.



**NOTE:** It is not required to have the awning at full extension. Awning may be stopped at any time of extension or retraction by releasing the momentary switch.



**NOTE:** Some models may require that the ignition key be turned to accessory or the ignition run position.

### To Retract the Awning:

- Verify all persons and objects are clear from the retract path of the awning and related hardware.
- Turn the One Touch key to the **ON** position.
- Depress and hold the momentary switch to **RETRACT**. The motor will automatically stop at full retraction.

- It takes approximately 14 seconds for the awning to travel from the fully extended position to the fully retracted position.
- Turn the One Touch key to the **OFF** position to avoid accidental deployment of the awning while the vehicle is in motion.

**Tips:**

If the awning fails to retract or extend:

- Verify the One Touch key is in the **ON** position.
- The house battery cut off switch is in the **ON** position.
- The house battery voltage is at 12 Volts or above.
- Verify proper electrical connection from the awning motor to the side of the motorhome.

**Emergency Retract Procedure:**

If the One Touch awning fails to retract and proper DC voltages have been verified, the One Touch awning has two emergency methods of alternately retracting the awning:

1. Two exposed electrical studs are mounted externally at the forward end of the awning at the motor assembly. An alternate 12 Volt DC positive and negative supply may be applied to these connections. If awning fails to move, reverse the polarity of the alternate supply leads.
2. On the motor assembly, mounted externally at the forward end of the awning, is an opening. Insert a 9/64" Allen hex wrench. Using an electric drill, wind the awning to the retract position.



**CAUTION: When using an alternate method to operate the awning use extreme care to keep appendages, hair or loose clothing away from exposed rotating hardware.**

To extend the sunvisor press and hold the lower portion of the control switch until the desired location is obtained. Once the desired point is obtained the sunvisor will remain in that position until changed. Retracting the sunvisor is the same as extending, except the upper portion of the switch is used. Cleaning the sunvisor should be done using a soft clean brush to remove dust.

## SUNVISOR (Optional)

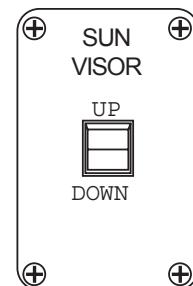
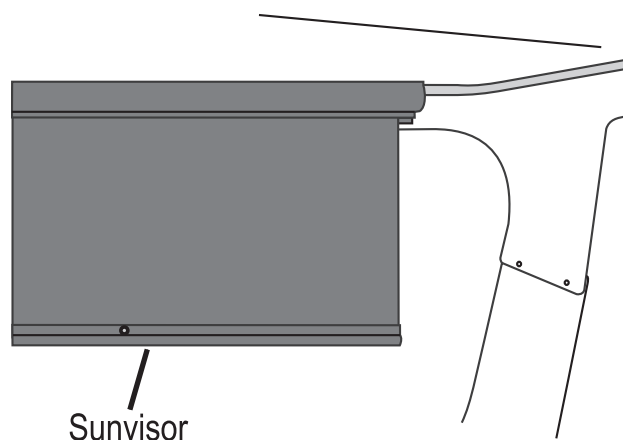

The sofa will convert easily into a bed. The sofa comes equipped with safety belts and these should be used if occupied during travel.

## SOFA TO SLEEPER

- Raise the sofa seat base until seat base and backrest form a V-Shape by lifting up from the center of sofa just below the seat cushions.
- Push down on seat base until the seat base and backrest are flat.
- Fold seat belts out of the way.

- Lift the seat base up until seat and back rest are in a V shape.
- Push down on seat base.

## SLEEPER TO SOFA

- The booth dinette easily converts into a bed.
- Lift seat cushions to an angled vertical position.
- With a firm grip, lift front edge of the table approximately six inches and push table leg lock to side.
- Swing the table leg up and lock into a horizontal position.
- Continue lifting table until table stays are clear of retainers. Pull outward and lower table down.
- Use both seat cushions and one back cushion for a mattress. Leave one back cushion in a vertical position.

## DINETTE BED CONVERSION (OPTIONAL)



**WARNING: Do not occupy the booth dinette or dining chairs while vehicle is in motion. They are not equipped with occupant restraint systems. Chairs must be stored in an enclosed area or secured with tie down straps prior to setting the motorhome into motion to avoid the risk of personal injury to motorhome occupants resulting from a crash or sudden stop.**

---

## **TO EXTEND FIXED DINETTE**

- To extend and add table top leaf unlock and slide it all the way out against stop.
- Lift leaf from storage compartment and place it on rails.
- Slide top and leaf against wall.
- Reverse procedure to store table top leaf.

---

## **STORAGE-UNDER BED & ENGINE ACCESS**

To use the storage compartment located under the bed, locate and unlock the bed deck latches. Lift up the bed by the front edge of the mattress platform. Gas struts hold the mattress and platform open. To access the engine compartment, press down on the button in each latch, open the engine hatch and secure the latch with the hook provided.



**NOTE: Do not over stress gas struts by rapidly opening or closing the bed access cover. This action can damage the struts or mounts. In extreme cold gas struts may not hold the mattress platform in the open position.**

# Diplomat

## SECTION 6 WATER SYSTEMS

<b>INTRODUCTION • 137</b>	<b>DRAINING WASTE HOLDING TANKS • 146</b>
<i>General Information • 137</i>	<i>What To Put In The Holding Tanks • 146</i>
<b>MONITOR PANEL • 137</b>	<i>Black Water • 146</i>
<b>WATER TANK FILL • 138</b>	<i>Grey Water • 145</i>
<b>WATER TANK FRESH GRAVITY FILL • 138</b>	<b>COLD WEATHER USE • 147</b>
<b>WATER CITY HOOK • 139</b>	<i>Bay Heater Operation • 148</i>
<b>WATER PUMP • 139</b>	<i>Cold Weather Package (Optional) • 148</i>
<i>Troubleshooting • 140</i>	<i>Storage • 148</i>
<b>WATER FILTER (Optional) • 141</b>	<b>WINTERIZING • 149</b>
<b>WATER SYSTEMS • 142</b>	<i>Using Air Pressure • 149</i>
<i>Troubleshooting • 142</i>	<i>Using Nontoxic Antifreeze • 150</i>
<b>DISINFECTING W/FRESH WATER • 142</b>	
<b>TANK CAPACITIES • 143</b>	
<b>WASTE WATER SYTEMS • 143</b>	
<i>Waste Drainage &amp; Sewage Tanks • 143</i>	
<i>What Not To Put In Waste Holding Tanks • 143</i>	
<i>Proper Waste Disposal • 144</i>	
<i>Connection To Available Sewer Hook-Up • 144</i>	
<b>TOILET • 144</b>	
<i>Operating Instructions • 144</i>	
<i>Trouble Shooting • 145</i>	
<i>Cleaning • 145</i>	
<i>Maintenance • 145</i>	
<i>Drip Traps &amp; Auto Vents • 145</i>	





## INTRODUCTION

### General Information

This section contains information and knowledge for the operation and care of the various water system equipment found in the motorhome. The motorhome is equipped with two separate water systems. Optional water equipment will also be discussed, so not all information may be applicable to your motorhome. More detailed information with **CAUTION** or **WARNING** instructions for the various equipment, other than what is found in this section, can be found in the manufacturer's manual in the owner information box.

It is hard to imagine how much water you use everyday when you are at home. Newcomers to self-contained motorhomes soon discover that water does not last very long unless consumption is drastically reduced. For instance, you can use less water for showering if you wet down, turn off water while soaping, then turn on water to rinse. This way a good shower uses a gallon or less of water. There is plenty of water to meet your needs once you adjust your habits.

#### Fresh Water System:

The fresh water system consists of fresh water tank, water pump, gravity fill connection, water filters and a city/fresh water connection.

#### Waste Water System:

The waste water system consists of a waste holding tank (grey water), a sewage holding tank (black water), flush system, toilet and drains.

The motorhome is equipped with a monitor panel to aid in managing the storage tanks. The monitor panel is located in the bathroom area. The switch marked test is a momentary switch which requires being held down while testing the level of the storage tanks. Read the scale for the desired storage tank which is to be monitored. Each scale uses colored lights along with a corresponding scale reading. The lights and scale indications are as follows:

- Green lamps indicate good or normal ranges.
- Amber lamps indicate fair or partial ranges.
- Red lamps indicate full or empty ranges (depending on the scale which are in the critical range).

## MONITOR PANEL

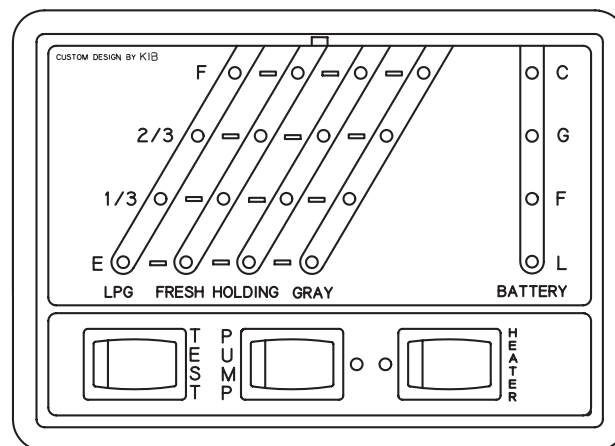

## WATER TANK - FRESH WATER FILL

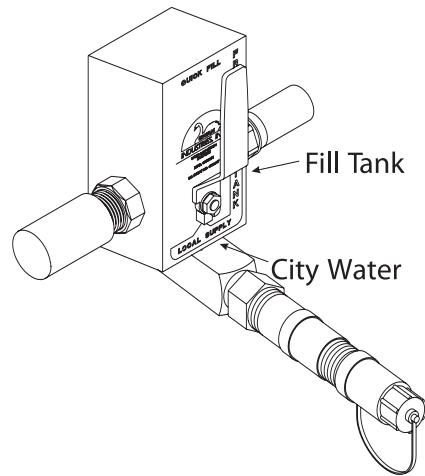

To fill tank close tank drain valve and connect hose to CITY/FRESH WATER FILL valve and to water source. Fill and drain valves are located in outside water connection panel compartment on roadside of motorhome. Turn valve to FRESH WATER TANK position. Turn on water and check level of tank on control panel while filling so that tank does not overflow. There is no automatic shut off on valve. There is an overflow drain in tank. Shut off water and unhook hose when tank is full.

## WATER TANK - (FRESH) GRAVITY FILL

The purpose of the gravity fill is to be able to introduce fluids directly into the storage tank. This is very useful for the dry camper, which can pack and pour bottled water directly in the hold tank. Being able to add antifreeze for winterization is made simpler with a gravity fill. You will also find disinfecting the water system can be made simpler.

1. Locate the fresh water gravity tank fill on outside water connection panel.
2. Unscrew the cap, taking care to keep it clean.
3. Connect the water hose marked potable water to the water source.
4. The water hose can stick down inside the gravity fill tube.
5. Turn on the water source, listen to the water rushing inside the fresh water tank.
6. The fresh water tank is full when water starts coming out of the gravity fill neck.

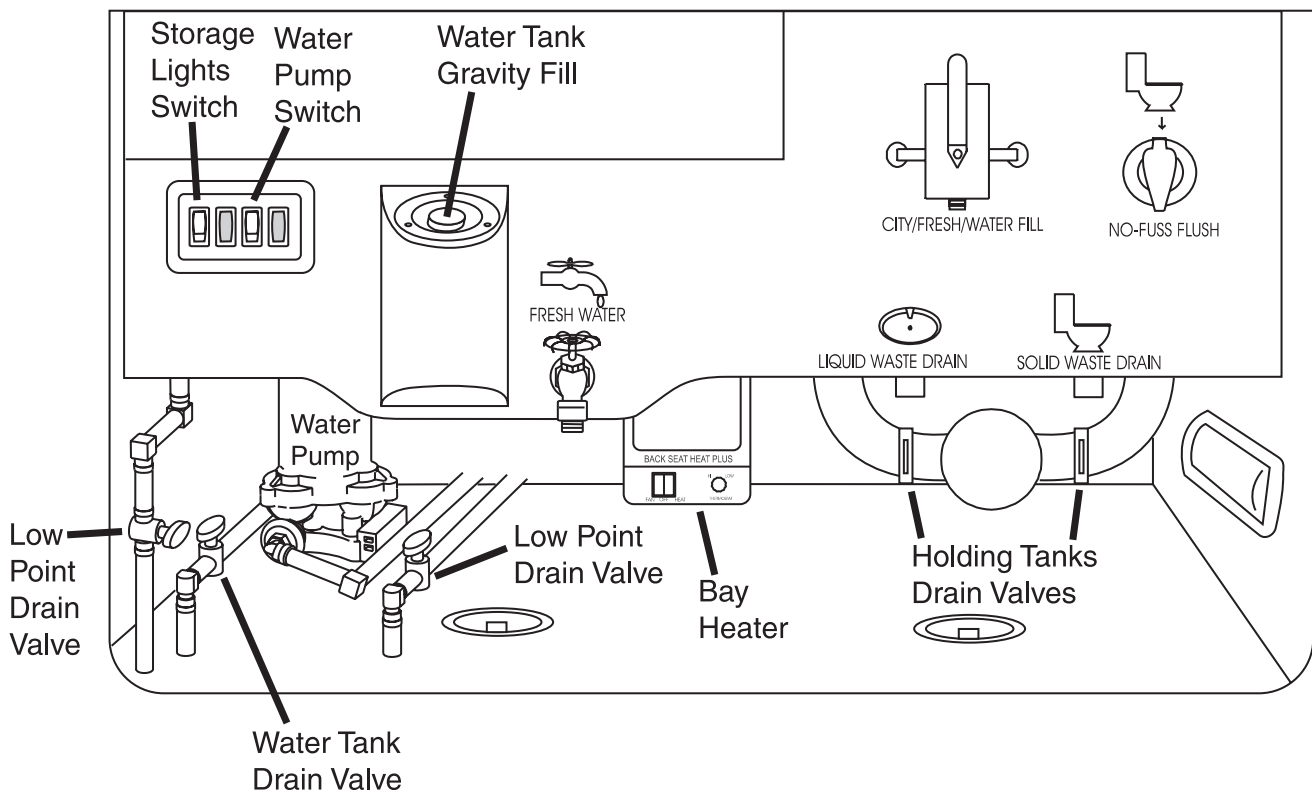



- Connect the hose to city/fresh water hook-up located on outside water connection panel.
- The city water valve must be in “LOCAL SUPPLY” position.
- Turn on the water supply.
- The water pump can either be in OFF position or in ON position. It will not affect the water pump to leave it on.

## WATER - CITY HOOK-UP

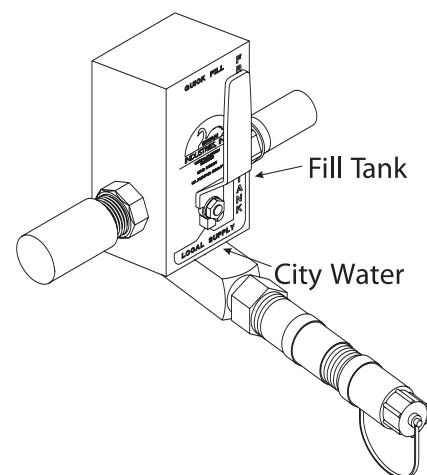

**CAUTION:** Some water sources develop high water pressure, particularly in mountainous regions. High water pressure is anything over 55 psi (pounds per square inch). Excessive water pressure may cause leaks in water lines and/or damage the water heater. The motorhome comes with a pressure regulator which should always be connected to the city water faucet to regulate hose and coach pressure.

The water pump is used to pressurize the fresh water system when it is not connected to city water. The water pump is totally automatic and self-priming, operating on demand as water is used. The water pump is located in outside water connection panel compartment.

## WATER PUMP

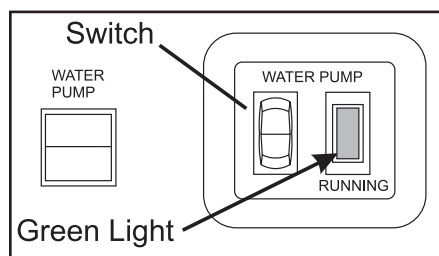

Water Pump Switches

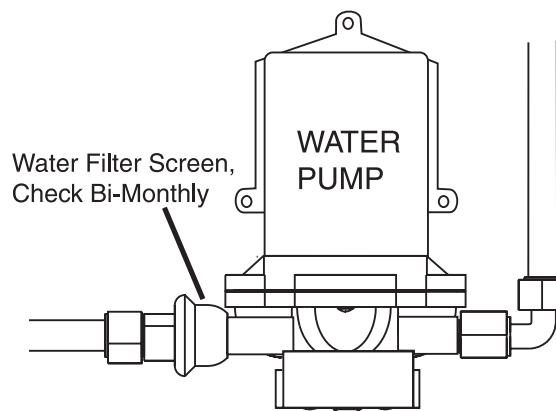

**WARNING:** Before leaving your coach for extended periods of time (i.e. overnight or longer) be sure that the city water and all water pumps have been turned off. Damage from neglect will be responsibility of the owner and not Monaco Coach Corporation.

To operate the water pump, push switch to “ON” position. The remote switches are located in the bathroom on the outside water control panel.

Do not allow the pump to run when the fresh water supply tank is empty. Continued operation with a dry tank may open an electrical circuit and/or damage the water pump.

**To start pump after unhooking city water supply or first time use proceed as follows:**

- Fill the fresh water tank.
- Open all valves and faucets except the drain valves. This includes hot and cold water valves, all faucets and shower.
- Turn the water pump on and wait for the water lines and the hot water tank to fill.
- Close each faucet when it delivers a steady stream of water (cold water faucets first).

---

**Troubleshooting**

Vibration induced by road conditions can cause the plumbing or pump hardware to loosen. Check for system components that are loose. Many symptoms can be resolved by simply tightening the hardware. Check the following items along with other particulars of your system.

**The water pump will not start/blows the circuit:**

- Check the electrical connections, fuse or breaker, main switch and ground connection.
- Is the motor hot? The thermal breaker may have triggered. It will reset when cool.
- Is the voltage present at the switch? Bypass the pressure switch.
- Does the pump operate?
- Check the charging system for correct voltage and good ground.
- Look for an open or grounded circuit or motor.
- Check for seized or locked diaphragm assembly (water frozen).

**The water pump will not prime/sputters (No discharge/motor runs):**

- Is the strainer clogged with debris?
- Is there water in the tank, or has air collected in the hot water heater?
- Is the inlet tubing/plumbing sucking in air at plumbing connections (vacuum leak)?
- Check for proper voltage with the pump operating.
- Look for debris in the pump inlet/outlet valves or dry/swollen valves.
- Check the pump housing for cracks or loose drive assembly screws.

**The water pump will not shut-off/runs when the faucet is closed:**

- Check to see if the fresh water tank fill valve is in "FRESH WATER TANK" position.

- Check output side (pressure) plumbing for leaks and inspect for a leaky toilet or valves.
- Look for loose drive assembly or pump head screws.
- Are the valves or the internal check valve held open by debris or is the rubber swollen?

**The water pump is noisy or rough in operation:**

- Check for plumbing which may have vibrated loose.
- Does the mounting surface multiply noise (flexible)?
- Check for mounting feet that are loose or compressed too tight.
- Look for loose pump head to motor screws (three long screws).
- Is the motor with the pump head removed? Is noise coming from the motor or pump head?

**The water pump is rapid cycling:**

- Look for restrictive plumbing/flow restrictors in the faucets or shower heads.

You need to replace filter with diverter cap before you disinfect water system with a chlorine solution. To change filter or replace filter with diverter cap use the following procedure.

**WATER FILTER  
(OPTIONAL)**

**To Remove:**

- Turn off water supply and water pump then open faucet to bleed off pressure.
- Lift locking lever up to a vertical position.
- Turn locking ring all the way left.
- Turn cartridge or diverter cap all the way left and pull down to remove.

**To Install:**

- Check that locking ring is all the way left and down. Align bump on cartridge or diverter cap with opening in a locking ring. Push new cartridge or diverter cap up into base and turn right until it stops.
- Turn locking ring right until it stops and lower locking lever so that it locks ring.
- Turn on water pump or city water.

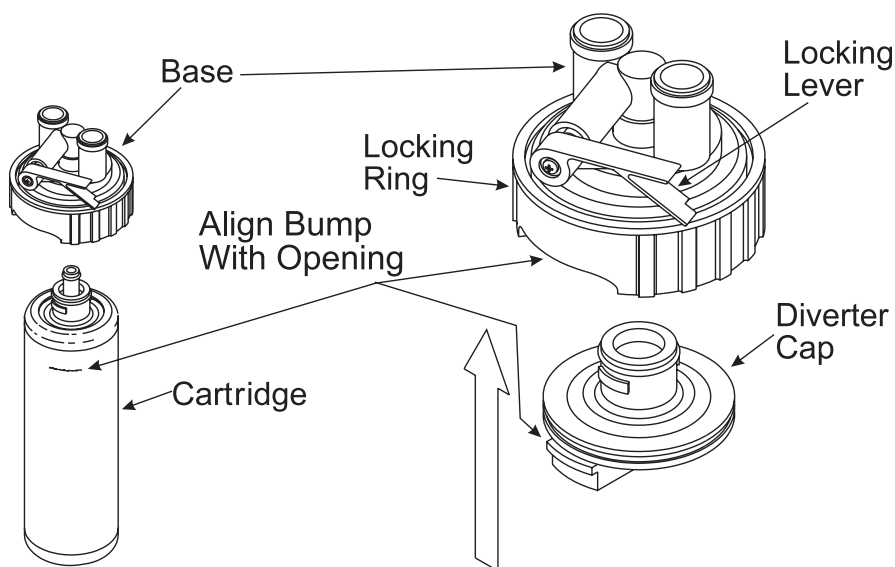

## **WATER SYSTEM - Troubleshooting**

Water system problems and leaks usually fall into two categories: system problems and problems caused by improper use or lack of attention. These problems usually stem from improper winterizing, poor maintenance, road vibration and campsite water pressure variations. Check all plumbing connections for leaks at least once a year. If the water pump runs when a faucet is not open, check for a water leak. Be sure the tank drain valves are closed. If the system continues to leak take your motorhome to an authorized dealer for service.

## **WATER SYSTEM - Disinfecting With Fresh Water**

Disinfecting water system with chlorine bleach (superchlorination) protects you and your family from bacteriological or viral contamination from any common water source.

### **You should disinfect the water system:**

- If your motorhome is new.
- If your motorhome has not been used in a long time.
- Every **three** months.



**NOTE: An independently operated water pump with garden hose connections and a container to hold prepared solution may be desired to perform this task. The gravity fill may also be used to perform the task. Remove cap off the gravity fill. Add the solution to the fresh water tank. When finished, secure the gravity feed cap.**

Use following procedure to disinfect water system:

- Remove water filter cartridge and replace filter with diverter cap (see WATER FILTER). Diverter cap comes with motor home and will be stored inside. With diverter cap installed it creates a bypass in water lines.
- Prepare a chlorine bleach solution using 1 gallon water and 1/4 cup of chlorine bleach. Use 1 gallon of solution for every 15 gallons of tank capacity. Example: Add 2-2/3 gallons solution to a 40 gallon tank. Add 4-2/3 gallons solution to a 70 gallon tank. Add 6-2/3 gallons to 100 gallon tank. This mixture puts a 50 ppm (parts per million) residual in the water system. This concentration will act as a quick-kill dosage for harmful bacteria, viruses and slime-forming organisms. Concentrations higher than 50 ppm may damage the water lines and/or tanks.
- Drain the fresh water tank. Close the drain and pump the solution (if desired) into the fresh water tank using an independently operated pump and a garden hose connected to City Water Hook-Up on the water control panel. It can be poured into the fresh tank using the gravity fill and a funnel. Open each faucet, in turn, and run the water until you smell a distinct chlorine bleach odor. Do not forget the hot water, tub

and shower faucets.

- Allow the system to stand for four hours.
- Drain the system and flush with fresh water. The drain is located in the outside water control compartment. Flush with fresh water repeatedly, if necessary, until no chlorine bleach taste or smell is left in the water system.
- Install new water filters.

## TANK CAPACITIES

TANK CAPACITIES					
Models	36B	36D	38A	38D	38PBD
Water Heater	10 Gal.	10 Gal.	10 Gal.	10 Gal.	10 Gal.
Grey Tank	60 Gal.	60 Gal.	60 Gal.	60 Gal.	60 Gal.
Black Tank	40 Gal.	40 Gal.	40 Gal.	40 Gal.	40 Gal.
Fresh Tank	100 Gal.	100 Gal.	100 Gal.	100 Gal.	100 Gal.
Fuel Tank	100 Gal.	100 Gal.	100 Gal.	100 Gal.	100 Gal.
LP Tank	38 Gal.	38 Gal.	38 Gal.	38 Gal.	38 Gal.

The waste drainage system was designed to provide adequate and safe storage and/or discharge of waste materials. All materials used in fabrication and installation of system is tested by a nationally recognized testing laboratory. The entire fabricated waste system is factory tested in accordance with American National Standards Code A119.2. The drainage system uses ABS plastic piping and fittings connected to sinks, shower, toilet and holding tanks and provides for their drainage to an outside termination. The motorhome should be reasonably level for optimum operation of the systems. There are two separate waste water systems: one for waste water (grey water) and one for sewage waste (black water). Each has its own storage tank, control valve and both empty through a sewer drain hose. When traveling it is recommend both holding tanks be empty or less than half full.

## WASTE WATER SYSTEMS Waste Drain & Sewage Tanks

- Do not use strong or full strength detergents to deodorize and disinfect. Use odor control chemicals made especially for holding tanks.
- Do not put automotive antifreeze, ammonia, alcohol or acetone in holding tanks. Some chemicals will dissolve plastic.
- Do not put large table scraps in the tanks. They could get stuck in or damage the valve seals.
- Do not flush facial tissues. They are treated chemically to strengthen them and will not dissolve like toilet

## What Not to Put in Waste Holding Tanks

paper. Special holding tank tissues are available at most RV supply stores. White toilet paper dissolves faster than colored papers.

---

### **Proper Waste Disposal**

Most State Parks have strict regulations about discharging wastes except into authorized disposal systems. Dumping raw sewage from toilet holding tanks, except at authorized dumping stations, is universally prohibited. Most National, State and private parks have either a central dump facility or campsite hook-up for sewage. Many of the modern rest areas along the interstate now have dump stations available. You will find a list of dumping stations from coast to coast in Woodall's Campground Directory, Trailer Life's RV Campgrounds and Services Directory, Rand McNally's Campground and Trailer Park Guide, Good Sam Park Director (Good Sam Club) and other publications. Some major oil companies offer dump facilities at selected stations. Plan ahead and you will find few inconveniences in proper and legal disposal of holding tank wastes.

---

### **Connection to Available Sewer Hook-Up**

When you park in an area with sewer hook-up available, the waste holding grey tank gate valve can remain open once you have connected to the sewer hook-up. Your sewage holding black tank valve must be closed at all times except when dumping. One thing you may want to consider prior to dumping your holding tanks is to allow enough fluid to accumulate in the grey tank before dumping. Then you dump the black tank first so the grey tank fluid may be used to flush the sewer hose.

---

### **TOILET Operating Instructions**

The toilet operates from either fresh water tank or city water supply. The water pump must be turned on or the city water connected. The toilet flushes directly into a sewage holding tank (black water).

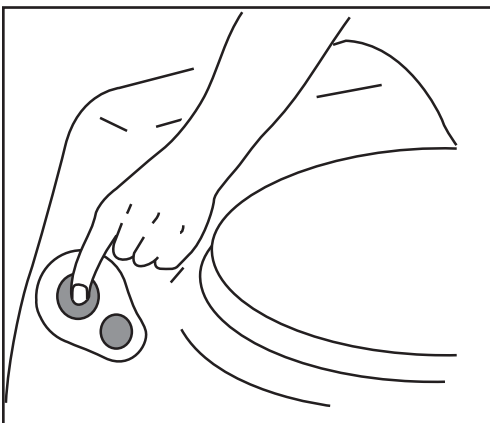

- To add water to the toilet before using press and hold small button until the desired water level is reached. Generally, more water is required only when flushing solids.
- To flush the toilet push the large button once.

**Leaks**

- Back of toilet: check water supply line connection.
- Between closet flange and toilet: Check screws for tightness. If leak continues, remove toilet and check flange height. Adjust, if necessary to 7/16" above floor. Replace flange seal if damaged.
- Poor flush: A good flush should be obtained within 2 to 3 seconds. If problem persists remove the water supply line and check flow rate. The flow rate should be at least ten quarts (9.5 liters) per minute.
- Bowl will not hold water: Check for foreign material in valve blade groove in the flush drain.

The toilet should be cleaned regularly for maximum sanitation and operational efficiency. Clean the toilet bowl with a mild bathroom cleaner. Do not use chlorine or caustic chemicals, such as drain opening types, as they will damage the seals.

Clean out the system by flushing several gallons of fresh water through with one cup of dry laundry detergent. Add odor control deodorant, in the amount specified for your holding tank capacity, after cleaning and every few days during use.

To find leaks check behind or under toilet. Take four or five sheets of toilet tissue and wipe all the seams and waterline connections. Start at the top of the unit and work downward. When the tissue comes in contact with leaking water it will immediately change texture.

**Cleaning****Maintenance**

**NOTE: Most chemical mixtures for holding tank odor control are poisonous. Follow the product manufacturer's directions and warnings when using any holding tank additive.**

Sinks, shower and clothes washer drains incorporate a water trap or "P-trap" and auto vents to prevent waste water holding tank odor from entering the motorhome. These P-traps for the most part are usually within 54" of a vent tee. These traps must have water in them to block odors. During storage water can evaporate and allow odor into motorhome. If odor is detected run water into sinks, shower and clothes washer to fill drain traps. The auto vent by design is to assist in the flow of water in the drain lines. They enable a smooth flow water in the drain without creating vacuum pressure in the lines.

The auto vent, if stuck in the open position, can allow grey odors to enter the motorhome. These auto vents also double as "clean outs" in the event you have to snake out a line.

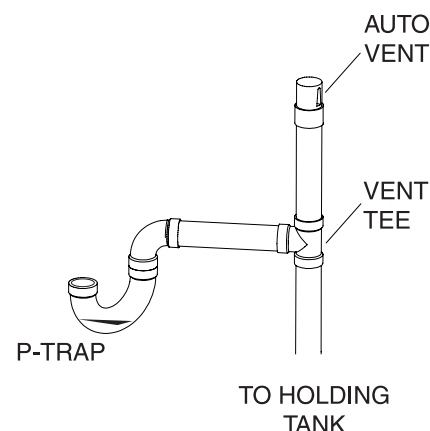
**Drain Traps & Auto Vents**



## DRAINING THE WASTE HOLDING TANKS

Before you start to dump your waste tanks, take a few minutes to exercise the drain pipe. Grasp both sides of the drain pipe firmly and swivel the pipe up and down. This will exercise the O-rings. When the drain pipe is pointed up turn the drain end cap counterclockwise and remove it from the drain pipe. This will prevent any residual spill from running out.

### To dump your waste holding tanks:

- Unscrew the bottom access hole plug from the service compartment. Feed the adapter end of the drain hose up through the hole and install the hose adapter on the drain pipe.
- Attach the other end of the drain hose to the sewer connection at the dump station.
- Rotate the drain pipe downward to maximize flow.
- Drain the sewage tank first by pulling the large T-handle gate valve out on the water connection panel. The sound of water rushing through the hose is audible.
- Flush the sewage tank. Connect the water supply hose to the SEWAGE TANK FLUSH connection on the water connection panel. This water supply hose should not be the same hose used to connect the city/fresh water hook-up. Ensure the T-handle gate valve remains open when flushing the sewage tank. Turn the water on and flush the system for approximately two minutes. Again, water running through the drain hose should be audible.
- Turn the water off and disconnect the water supply hose when finished flushing the system.
- After you have drained and flushed the sewage tank, drain the waste water tank by pulling the T-handle out on the water connection panel.
- Flush the waste holding tanks with fresh water before closing the gate valves. The waste water tank is flushed by pouring two gallons of water down a sink drain.
- Run the toilet water to flush the sewage tank.
- Push both T-handles in and install the end cap (required in some states) when in transit to prevent leakage.
- Flush the drain hose with either the water supply hose or the exterior faucet sprayer and secure in travel location.



**WARNING: When using the black tank flush do not leave the motorhome unattended or flooding may occur. Turn off the water supply to the black tank flush when finished.**



The sewage tank stores toilet drain waste only. Before using the toilet you need to treat the sewage holding tank with water that is mixed with an odor controlling chemical. These chemicals are readily available at any RV supply store. The chemicals are poured into the holding tank through the toilet. Mix the chemicals with approximately one gallon of water. Be careful not to spill the chemical on your hands, clothing or carpet as it can cause permanent stain. Extremely hot weather areas may require adjusted amounts of chemical to help with odor control. Each time the holding tank is dumped repeat the chemical mixing.

### ***What to Put into the Holding Tanks - Black Tank***



**CAUTION: Do not use any products that contain petroleum or ammonia in place of an RV odor controlling chemical. Petroleum and ammonia will damage the ABS plastic holding tanks and seals.**

The waste tank stores sinks, shower and clothes washer drain water. No chemical is required in this holding tank; however, keep in mind this is a waste holding tank and can produce odors. A reduced mixture of chemicals may be used for odor control.

### ***What to Put into the Holding Tanks - Grey Water***

Prior to dumping the the waste holding tanks be sure there is enough liquid in the holding tanks to provide a smooth flow through the valve drain pipe and drain hose. When sufficient liquid is in the tank a swirling action will result that should take accumulated solid wastes along with the waste liquid when the tank is dumped. The tanks should be emptied when they reach ½ full, or weekly, to prevent stagnation and overfilling.

A motorhome is not designed for extended use in below freezing (32° F/0° C) weather; however, you may not experience any problems as long as the temperature does not drop too low.

### **COLD WEATHER USE**

Interior water lines, fixtures, water storage tanks and pumps are normally protected from moderate freezing temperatures as long as the furnace is operating.

Exposed drains may freeze quickly. If in doubt about what temperatures the motorhome will tolerate winterize with a potable antifreeze.

Exterior water control bay has a 12 Volt electric heater to warm the bay in cold weather. Heater should be turned on when ambient temperatures approach 44° F.

## Bay Heater Operation

The heater is controlled using two switches, one on the heater itself and a remote "SYSTEMS HEAT" switch located in an inside overhead compartment next to entrance door. Both switches must be in ON position for the heater to operate. Either switch in the OFF position will turn the heater off.

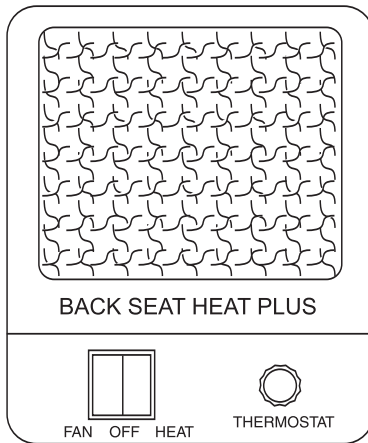

### Heater has two controls

#### 1. Function Select Switch:

- Left Position: Fan only on.
- Middle Position: Heater off.
- Right Position: Both fan and heater on.

#### 2. Thermostat:

- Rotate right or clockwise to increase temperature setting.
- Rotate left or counter clockwise to reduce temperature setting.

## Cold Weather Package (Optional)

The cold weather package consists of one 12 Volt electric heating pad attached to each holding tank. Heating pads are turned on and off using the same "SYSTEMS HEAT" switch, located in an inside overhead compartment next to entrance door, that turns on the bay heater. Pad operation is controlled by a thermostat designed to turn on at 44° F and off at 64°F. Power to pads should be turned ON when ambient temperatures approach 44° F. There must be liquid in the holding tanks when the pads are turned on.



**CAUTION: Turn OFF power to pads when dumping the holding tanks, plugging motorhome into shore power and when starting the electric generator to prevent damage to the pad thermostat.**

## Storage

If you are storing the motorhome where freezing temperatures may occur you will need to drain the domestic fresh water loop completely of water. When draining the domestic fresh water system start off by draining the fresh water tank. This is accomplished by simply opening the point drain lever for the fresh tank and allowing the water to drain.



**NOTE: Ice makers, water filters, water purifiers, water heaters and washers all use domestic water and should be drained and stored in accordance with the manufacturer's recommendation for winterization.**

## WINTERIZING Using Air Pressure

How you decide to store your motorhome and protect the water lines is up to you. You can elect to have the lines air blown to remove standing water or fill the lines using an approved FDA RV antifreeze. Either way all interior and exterior faucets will need to be opened and closed, one at a time, to be checked. All low point drains should be opened and holding tanks emptied.

To use air pressure to winterize your motorhome you will need access to an air compressor and adapter to connect the air line to your water system. Adapters can be found at any RV supply store. You should not exceed 40 psi when hooked to the water lines. Higher pressure will damage the lines.

1. Remove water filter cartridge and replace filter with diverter cap (see WATER FILTER). Diverter cap comes with motorhome and will be stored inside. With diverter cap installed it creates a bypass in water lines.
2. Drain the fresh water tank and lines by opening the tank drain valve and the low point drain valves located in the outside water control service compartment of the motorhome.
3. Let all the water drain. Turn the pump on and allow it to run so that all the water is cleared out of the pump and lines. Turn the pump off.
4. Remove water heater drain plug and open pressure release valve located in the outside water heater access compartment.
5. After the water is drained, hook an air hose to the city water connection located on the water control panel in the outside service compartment. Blow out the water lines until no further water can be seen coming out of the drain lines. Do not exceed 40 psi in the water lines and faucets.
6. Move water heater bypass valve to BYPASS setting located next to water heater. Replace the water heater drain plug and close the pressure release valve. Open all faucets (including the outside spigot) one at a time while the air is on, to clear water from the faucet supply lines. Do not forget to drain your shower.
7. Flush toilet repeatedly until the water has stopped running.
8. Turn the air off and unhook the air hose.
9. You will need 1 gallon of RV antifreeze to protect various water drain lines in your motorhome. Pour 1 pint into both the kitchen and bath shower drains. Pour 2 pints into the bath sink drain, with some of the

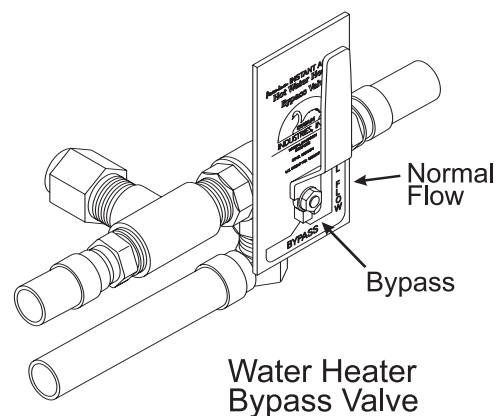
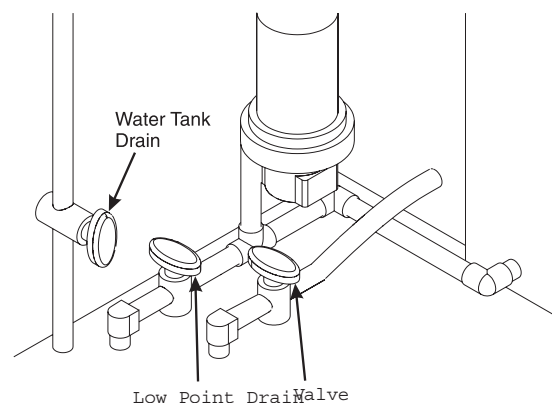

antifreeze going into grey tank to protect the drain valve. Press both toilet buttons at the same time, TWICE, to open valve blade. Pour 3-1/2 pints into the toilet, letting the antifreeze run into the black tank to protect the valve located there. Press toilet flush button to close valve blade. Pour the last pint of antifreeze into the toilet. Use a soft cloth to wipe out the sinks and shower after you pour in the antifreeze to protect the surfaces from stains.

10. Leave the low-point and fresh water tank drains open until you are ready to use your motorhome again.



**WARNING: When draining the low water drain lines and the water heater be sure the water is not hot. Hot water from the lines can burn you.**

If you choose to fill the water lines with antifreeze, you will need 10 gallons of FDA RV winterizing antifreeze.

---

## **WINTERIZING - Fresh Water System Using Nontoxic Antifreeze**

1. Remove water filter cartridge and replace filter with diverter cap (see WATER FILTER). Diverter cap comes with motor home and will be stored inside. With diverter cap installed it creates a bypass in water lines.
2. Drain the fresh water tank and lines by opening the tank drain valve and the low point drain valves located in the outside water control service compartment of the motorhome.
3. Let all the water drain. Turn the pump on and allow it to run so that all the water is cleared out of the pump and lines. Turn the pump off.
4. Remove water heater drain plug and open pressure release valve located in the outside water heater access compartment.
5. After the water is drained, move water heater bypass valve to BYPASS setting located next to water heater. Replace the water heater drain plug and close the pressure release valve.
6. Close the fresh water tank drain valve and the low point drain valves.
7. Pour the antifreeze into the fresh water tank using the gravity feed opening.
8. Turn ON the system water pump and operate each faucet individually until a small amount of antifreeze is present. Open the shower faucets and flush toilet repeatedly to allow a small amount of antifreeze to run into the holding tanks.

9. Use a soft cloth to wipe out the sinks and shower to protect surfaces from antifreeze stains.
10. Exterior faucet should be opened and closed using the same procedures as the interior faucets.
11. If the motorhome is equipped with an ice maker, remove the 3/4 inch fitting and flush antifreeze through the water line.
12. Disconnect the power supply line affecting water pump operation.

For de-winterization, drain the fresh water tank and fill the tank with water. Reconnect the power supply line for the water pump. Open all faucets, one at a time, until clear water is present. Open the shower faucets and flush toilet until clear water is present.



**WARNING: You should use only non-toxic RV antifreeze that is specifically made for potable water systems. Automotive antifreeze, if ingested, can cause blindness, deafness or death.**



**WARNING: It is recommended that this procedure be done by a qualified RV service technician familiar with motorhomes, such as your authorized selling dealer.**

**NOTES**

# Diplomat

## SECTION 7 LP-GAS SYSTEMS

<b>LP - GAS SYSTEM • 155</b>
<b>LP - GAS DETECTOR • 156</b>
<i>Operation • 156</i>
<i>Testing • 156</i>
<i>Care of the Detector • 157</i>
<b>MONITOR PANEL • 158</b>
<i>Measurement &amp; Calibration • 158</i>
<b>CHECKLIST LP - GAS EMERGENCY PROCEDURES • 158</b>
<b>LP - GAS TANK • 159</b>
<b>LP - GAS REGULATOR • 160</b>
<b>LP - GAS CONSUMPTION • 161</b>
<b>LP - GAS DISTRIBUTION LINES • 161</b>
<b>LP - GAS TANK • 161</b>







**LP-GAS SYSTEM**

This section contains information and knowledge for the operation and care of the various Liquefied Petroleum (LP-Gas) system equipment found in the motorhome. The motorhome is equipped with several appliances and various equipment which are capable to operate on LP-Gas. Some items discussed may not be applicable to your motorhome. More detailed information with **CAUTION** or **WARNING** instructions for the various equipment, other than what is found in this section, can be found in the manufacturer's manual in the owner information box.

All components for your motorhome LP-Gas systems are approved for use in camping vehicles by a nationally recognized testing laboratory. When properly handled, LP-Gas is a clean-burning dependable fuel for heat producing components. The LP-Gas tank mounted in your motorhome contains liquid petroleum gas under high pressure. As fuel is used, liquid gas vaporizes and passes through the tank valve to a regulator that automatically reduces pressure. Low-pressure gas is then distributed to components through a pipe manifold system.

Component lighting problems are commonly caused by an improperly adjusted gas regulator. Never attempt to reset regulator yourself. Have your dealer or an authorized service person make adjustments.

In higher elevations or extreme cold weather (10° F/-21° C or lower) you may experience a shortage of LP-Gas. You can adjust to this by not running more than one component at a time, such as turning off furnace while using the range. If you are going to be in higher elevations or cold climates for a long period of time an authorized service person can adjust your LP-Gas regulator for these conditions.

We recommend that you have the LP-Gas system checked by an authorized dealer at least once a year, and thereafter every extended trip. Although manufacturer and dealer both test carefully for leakage, travel vibrations could loosen fittings.

Leaks can be easily found by applying leak detector solution at connections. If leak detector solution is not available a soapy water solution made with dish soap can be used. Tightening fittings usually stops any leaks. If not, shut off main gas valve at tank and see your authorized dealer for repairs immediately. Hand tighten tank valves only, do not use a wrench or pliers as over tightening may damage valve seats and cause them to leak. If you suspect a leak, which is an easily identified odor (smells like rotten eggs/sulfur) never light a match or have an open flame.

## LP-GAS DETECTOR

Provided for safety is a gas detector. This gas detector will detect both LP-Gas and Methane Gas. Liquefied Petroleum (LP) Gas is heavier than air; Methane Gas is lighter than air. LP-Gas will settle to the lowest point, generally the floor of the motorhome. Methane Gas will rise. The gas detector is also sensitive to other fumes such as hair spray, of which most contain butane as the propellant. Butane, like propane, is heavier than air and will settle to the floor level where it will be detected. When this occurs, press reset button to stop alert sound for 60 seconds.

The other combustibles which will be detected include alcohol, liquor, deodorants, colognes, perfumes, wine, adhesives, lacquer, kerosene, gasoline, glues, most of all cleaning agents and propellant of aerosol cans. Most are lighter than air in their vapor state and will only be detected when the motorhome is closed up.



LP Detector

### Operation

Upon first application of power the LED will flash yellow for 3 minutes while the detector is stabilizing. At the end of the start cycle the LED will turn Green indicating full operation. If detector senses unsafe levels of gas it will immediately sound an alarm.

The gas detector operates on 12 Volts, with a current draw less than 1/10th of one amp.



**CAUTION: This detector will not alarm during the 3 minute warm up cycle.**

### Testing

Depress the TEST switch any time during the warm up cycle or while in normal operation. The LED should flash RED and the alarm should sound. Release the switch. This is the only way you should test your detector. The test feature checks full operation of the detector.



**WARNING: Test the operation of this detector after the motorhome has been in storage, before each trip and at least once per week during use.**

The Red LED will flash and the alarm will sound whenever a dangerous level of propane or methane gas is detected. The detector will continue to alarm until the gas clears or the Mute switch is pressed.

**Procedures To Take During An Alarm:**

1. Turn off all gas appliances (stove, heaters, furnace), extinguish all flames and smoking material.  
Evacuate, leave doors and windows open.
2. Turn off the propane tank valve.
3. Determine and repair the source of the leak. Seek professional help if necessary.



**CAUTION: Do Not re-enter until the problem is corrected.**

**Alarm Mute:**

Press the Test-Mute button when the detector is in alarm.

1. The Red LED will continue flash and the alarm will beep every 30 seconds until the gas level has dropped to a safe level.
2. The LED will flash Green until the end of the Mute cycle.
3. If dangerous gas levels return before the end of the mute cycle the alarm will beep 4 times and return to phase 1.
4. After 2 minutes the detector will return to normal operation (solid Green) or resound the alarm if dangerous levels of gas remain in the area.

**Fault Alarm:**

Should the microprocessor sense a fault in the gas detector, a fault alarm will sound twice every 15 seconds. The LED will alternately flash Red to Green and the MUTE switch will not respond to any command. The gas detector must be repaired or replaced.

- 
1. Vacuum the dust off the detector cover weekly (more frequently in dusty locations) using the soft brush attachment of your vacuum.
  2. Do not spray cleaning agents or waxes directly onto the front panel. This action may damage the sensor, cause an alarm or cause a detector malfunction.

***Care of  
the Detector***

## MONITOR PANEL Measurement & Calibration

Tank Measurement - To measure level of a tank simply push button on display panel corresponding to tank you wish to measure. Lights on panel will turn on in sequence indicating level of tank.

Calibration - The monitoring panel comes factory calibrated for accuracy and should not need to be adjusted.

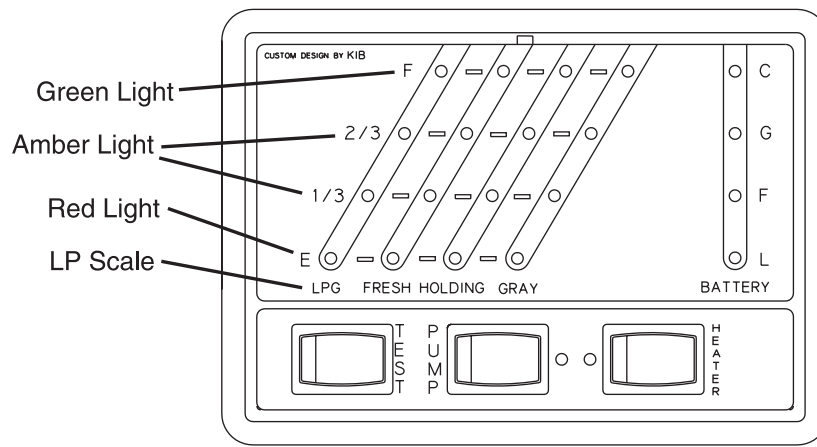

## CHECKLIST- LP-GAS EMERGENCY PROCEDURES

If you smell gas (a rotten egg or sulfur smell) at any time, perform the following steps immediately:

- Shut off gas appliances.
- Manually turn off the main gas supply at the tank.
- Do not attempt to operate any electric switch.
- Open windows and doors.
- Evacuate the motorhome.
- Keep open flames, spark producing devices and smoking material out of the area.
- Contact a qualified service technician to find the source and repair the gas leak.



**WARNING: A fire or explosion from ignited gas or gas fumes can seriously injure you or cause death.**

## LP-GAS TANK

Woodall's Campground and Trailer Guide and other publications list refueling stations. Many travel parks sell LP-Gas. Shut off the pilot lights, appliances and igniters before filling the LP-Gas tank to prevent a fire or explosion. Have a trained service person fill the LP-Gas tank.

The LP-Gas tank fill and bleed valves are located in the LP-Gas tank access outside compartment. Caution the service technician, if your tank is new and being filled for the first time, to purge any air from the tank before filling. When the tank is filled to the proper level there is space available for the conversion of liquid into gas. If a tank is over filled it may vent pressure. When this happens you may detect a strong rotten egg odor near the tank and/or hear a hissing noise.

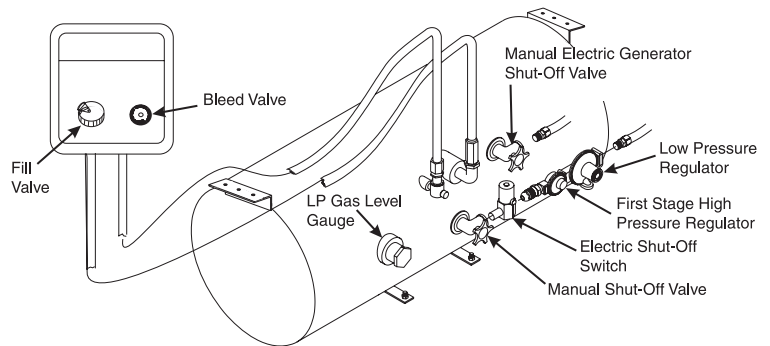

**WARNING: Turn off all pilot lights and appliances during the refueling of the motorhome and filling the LP-Gas tank to prevent a fire or explosion.**

LP-Gas exists in both the liquid and vapor state with the LP-Gas tank. A "Full" tank is approximately 80% liquid. The pressure inside the tank varies with the temperature of the liquid. All tanks are required to be equipped with a pressure relief device. The purpose of the relief valve is to release gas or liquid caused by over pressurization. You will notice the gauge at the tank, when full, will only read 3/4. Your monitor panel is adjusted to indicate FULL at this point.

If you are storing portable LP-Gas tanks (do not transport or store LP-Gas tanks, gasoline or other flammable liquids inside the motorhome) that are not connected to an LP-Gas system install an approved plug in the tank outlet holes to prevent leaks. Do not store empty LP-Gas tanks. Keep open flame and spark producing materials away from the LP-Gas area. If this warning is ignored a fire or explosion could result. Shut off all appliances and LP-Gas tank valves (located on side of LP-Gas tank underneath the motorhome) when the motorhome is in storage.



**CAUTION: Pressure inside LP-Gas tanks can reach over 300 psi when exposed to direct sunlight. A high pressure safety relief valve will purge excess high pressure if necessary. LP-Gas will stop vaporizing as the LP-Gas tank temperature approaches -40° F. Appliances which consume large amounts of LP-Gas, such as the water heater or furnace, will need to be operated in sequence in extremely cold environments.**

## LP-GAS REGULATOR

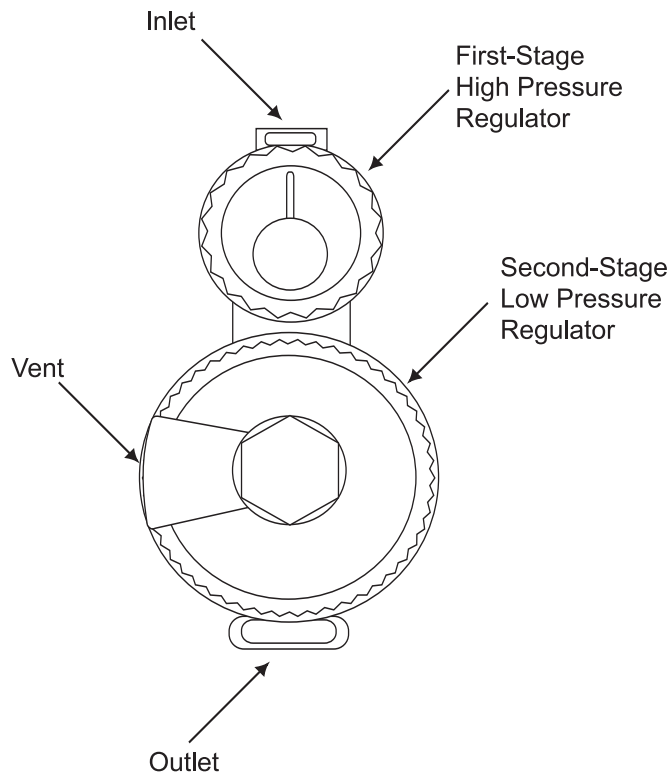

LP-Gas Regulator

The regulator is the heart of an LP-Gas system. The LP-Gas in the tank is under high pressure. The regulator reduces the pressure of gas so that it is safe to use with various appliances. The regulator on the motorhome is a two-stage regulator. Simply put, the first stage regulator reduces the full tank pressure down to a range of 10-13 psig. The second stage further reduces the pressure down to an outlet pressure of 0.4 psig (11 inches of column water). The regulator is equipped with a vent so that it can breathe. This means that if pressure in the LP tank is too high the regulator will allow gas to escape through the vent until pressure returns to a normal range. It is important to keep the vent clean and clear of obstructions or corrosion. If the vent becomes clogged, pressure from LP tank could cause a failure of the components. If you notice any corrosion contact a qualified LP-Gas service technician. The regulator is mounted so that the vent faces downward. If the vent becomes clogged you can clean it with a toothbrush.

Under normal atmospheric conditions a LP regulator will not freeze, nor will the LP-Gas. The gas passing through the regulator will expand and cool creating moisture in the gas. This moisture will turn to ice which can build up and partially or totally block the orifice. The possibilities of freeze up is greatly reduced with the two stage regulator.

Things you can do to prevent this freeze up are:

1. Ensure the LP tank is totally free of moisture prior to filling.
2. Ensure the tank is not overfilled.
3. Keep the valve closed when the tank is empty.
4. A LP-Gas dealer will need to purge the tank if freeze up occurs.
5. Have the LP-Gas dealer inject methyl alcohol in the tank.



**WARNING: Do not attempt to adjust the regulator, it is pre-set at the factory. If adjustments need to be made it requires special equipment. Failure to follow these instructions may result in a fire or explosion and cause severe personal injury or death. DO NOT ATTEMPT TO REENTER THE MOTORHOME UNTIL THE PROBLEM HAS BEEN CORRECTED!**

## LP-GAS CONSUMPTION

Each gallon of LP-Gas produces approximately 92,000 BTU's of heat. One 27 gallon tank produces two million BTU's. Total consumption depends on the rate of usage by each appliance and the operating time. The stove and heating systems typically use the most gas. With sub-freezing temperatures and high winds, consumption by the furnace can be very high. Check the tank level often in cold weather.



**WARNING: LP-Gas is highly volatile and extremely explosive. Never use matches or open flame to test for leaks. Use only approved LP-Gas leak testing solution to test for leaks. Unapproved solutions can damage copper tubing and brass fittings. Never attempt to adjust LP-Gas regulators without the use of proper equipment. Improper LP-Gas regulator adjustment will affect the performance of LP-Gas operated appliances. Incorrect flame or explosion can occur. Only qualified personnel should preform any maintenance or repair to the LP-Gas system.**

A primary manifold black steel pipe running throughout the motorhome distributes LP-Gas to secondary lines. All secondary lines leading to gas appliances are made of copper tubing with flared fittings. If any lines rupture do not attempt to splice them. Always run a new line. We recommend gas distribution work be performed by an authorized dealer or an authorized service technician. When removing or servicing any gas appliance, manually close the main valve located on the side of the LP-Gas tank. This will prevent dangerous gas leakage that could result in an explosion and possible serious injury. If you suspect a gas leak get the system inspected and repaired by a qualified service technician as soon as possible.

## LP-GAS DISTRIBUTION LINES

- Manually open the main shut-off valve located on the roadside of the LP-Gas tank.

## LP-GAS TANK -Operation

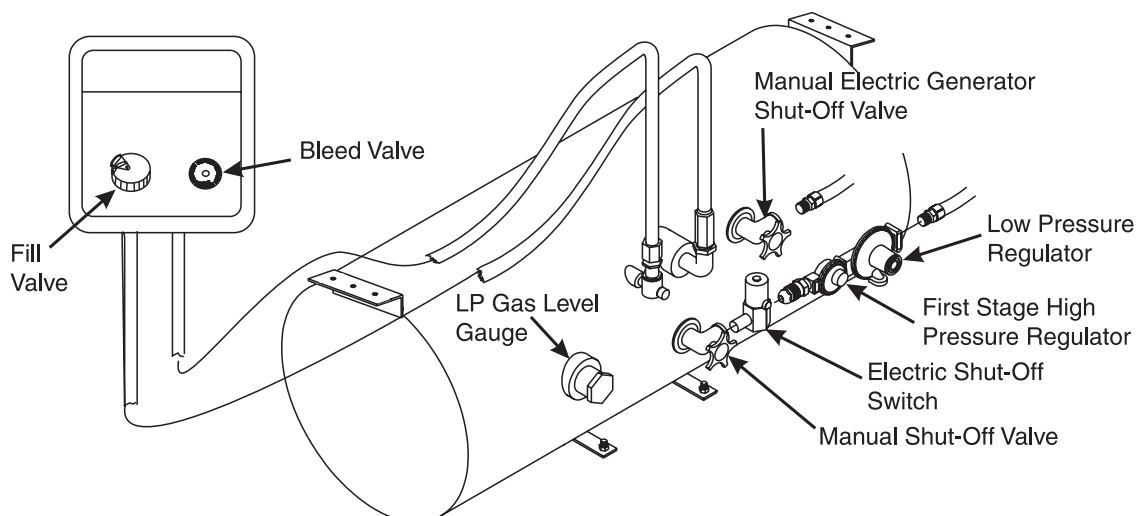

**LP-GAS TANK**  
*Continued.....*

- Turn off the manual valve on the LP-Gas tank when the motorhome is in between trips.
- Hand tighten the manual valve. Do not use a wrench or pliers to close the valve.
- The manual valve is designed to be closed by hand, over tightening may permanently damage the valve seat.

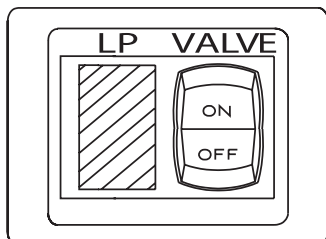

Outside Electric Switch

There is an LP -Gas electric shutoff switch located in LP tank compartment on curbside of motorhome for use during trips. When switch is ON red indicator light will be lit.



# Diplomat

## SECTION 8 ELECTRICAL SYSTEM - HOUSE

<b>INTRODUCTION • 165</b>	<b>DISTRIBUTION PANEL - HOUSE 110 • 180</b>
<i>Shore Power • 165</i>	<i>AC Panel • 180</i>
<i>Generator • 165</i>	<b>ENERGY MANAGEMENT SYSTEM - 50 AMP</b>
<i>Inverter/Converter • 165</i>	<b>(OPTIONAL) • 181</b>
<b>BATTERY DISCONNECT - HOUSE • 166</b>	<b>DISTRIBUTION PANEL - HOUSE 12 VOLT • 184</b>
<b>SHORE POWER HOOK-UP • 167</b>	<i>Fuses • 184</i>
<i>Transfer Switch • 168</i>	<i>Tools of the Trade • 184</i>
<b>GENERATOR - 120 AC • 168</b>	<i>Know When to Say No • 185</i>
<i>Prestart Checks • 168</i>	<b>BATTERY - HOW IT WORKS • 185</b>
<i>Starting the Generator • 169</i>	<i>Battery Types • 186</i>
<i>Stopping the Generator • 169</i>	<i>Starting Battery • 186</i>
<i>Powering the Equipment • 170</i>	<i>Deep Cycle Battery • 186</i>
<i>Resetting the Circuit Breaker • 170</i>	<i>Battery Maintenance • 186</i>
<i>Generator Exercise • 171</i>	<i>Battery Trays • 187</i>
<b>INVERTER/CONVERTER • 171</b>	<i>Testing the Battery • 188</i>
<i>Operating the Inverter • 172</i>	<i>Seven Reasons Why Batteries Fail • 189</i>
<i>Troubleshooting Inverter/Converter • 176</i>	<i>Battery Voltage &amp; Current • 190</i>
<i>Battery Charging with the Inverter • 177</i>	<i>Battery Charge Time &amp; Consumption Rate • 191</i>
<i>Battery Temperature Sensor (BTS) • 178</i>	<i>Battery Specifications • 192</i>
<b>RC-9 REMOTE CONTROL • 178</b>	<b>BULB USAGE - INTERIOR • 193</b>
<i>Operation • 178</i>	



## INTRODUCTION

The motorhome 120/240 Volt AC system can be operated from three different power sources. Shore power is the most efficient and should be used whenever possible. The on board generator has a limited amount of 120 Volts AC output power. This can be used when shore power is unavailable. The inverter/converter supplies silent AC power by the use of the motorhome's house batteries. This source has limited AC power output and should be used sparingly.

The motorhome 120 Volt AC circuit breaker panel is supplied with power from two different sources: 50 amp shore power cord or the on board generator. The selection of the power source being used is done automatically by the use of an automatic electrical switching device known as a transfer switch.

The power requirement for the motorhome is 50 AMP 120/240 Volt AC single phase. If 50 amp shore power service is available connect the motorhome to the 50 amp shore power source using the supplied shore power cord. One end of the shore power cord plugs into the 50 amp shore power source and the other plugs into the motorhome receptacle. The motorhome 50 amp shore power receptacle is located on the left side of the motorhome in the utility center.

### ***Shore Power***



**NOTE: In many instances 50 amp shore service is not available and care will have to be used when operating the appliances and using the outlets so as not to overload the shore power service being used.**

The generator can be selected for use when AC shore power is not available. The motorhome's on board generator has limited 120 Volt AC power output capabilities. The generator's maximum amount of output power is specified in watts, which is calculated at an elevation of 500 feet above sea level. The figure will decrease with a higher altitude. Temperature also affects total maximum output. Fuel consumption is based upon a percentage of AC electrical load applied to the generator. While using the generator, care will have to be taken when operating appliances and outlets so as not to overload the generator. The generator is fueled from the main fuel tank.

### ***Generator***

The inverter/converter can be used for silent AC power if shore power is not available, and using the generator is not going to be selected as a secondary power source option. This device has limited AC power output, measured in watts. It operates only selected appliances and outlets. The inverter/converter is two components in one. Its first function is as an auxiliary 120 Volt AC power source that uses 12 Volt DC house battery power to invert to 120 Volts AC. The second function of the inverter/converter is to use 120 Volts AC power, supplied from either shore power or the generator, and convert it to 12 Volts DC power to recharge the batteries.

### ***Inverter/ Converter***

## BATTERY DISCONNECT - HOUSE

The main house battery disconnect switch turns the battery power supply on or off. The domestic battery disconnect switch shuts off the 12 Volt DC power to the following items: the inverter, the domestic fuse panel in the

bedroom, the domestic fuse panel in the front run box and the domestic power supply in the rear run box(s). Turn the main battery disconnect switch off when the motorhome is going to be stored or before performing electrical maintenance on the motorhome. If possible, leave the motorhome plugged into an AC source with the battery disconnect switch on. This will help prevent the possibility of dead batteries. There are small (parasitic) loads that are present on the house battery. Some are federal mandate items such as the LP-Gas detector. If an AC source is not available and the motorhome is not going to be used or is stored more than 48 hours, it is recommended to turn the battery disconnect switch off.

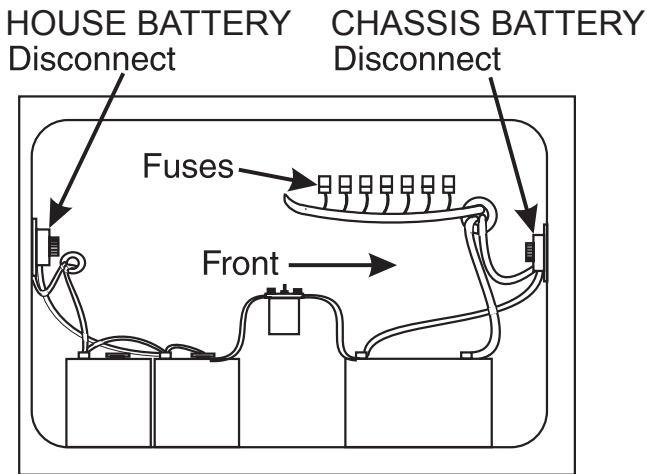

**WARNING:** When the frame or other welding is involved for motorhome repair or modification, the following precautions are required to protect electronic components in the motorhome chassis:

1. Disconnect the (+) positive and (-) negative battery connection, and any electronic control ground wires connected to the frame or chassis.
2. Cover electronic control components and wiring to protect from hot sparks.
3. Disconnect the wiring harness connector at the transmission electronic control unit. Open bed storage compartment, open engine access door. The transmission ECU is located above the transmission.
4. Do not connect welding cables to electronic control components.
5. The welding ground cable should be attached no more than two feet from the part to be welded.

# SHORE POWER HOOK-UP

If 50 amp shore power service is available all that is necessary is to connect the motorhome to the 50 amp shore power service using the supplied shore power cord. The cord is located in the compartment on the driver's side of the motorhome. After connecting the unit to shore power wait approximately one minute for the inverter to "stabilize" charging of the batteries before starting air conditioners or other large AC loads. In many instances 50 amp shore service is not available. Proper electrical adapters must be used to connect the supplied shore power cord to the shore service available. When connecting to anything other than 50 amp shore service use caution not to overload the supplied shore service breaker. Appliances and outlet loads will have to be operated in sequence, rather than all at the same time.



**NOTE: Below are the three types of shore power outlets most commonly used.**



**CAUTION: Avoid the risk of electrical shock or component damage by disconnecting from shore power during electrical storm activity. Use the inverter or start the generator if AC power is needed.**

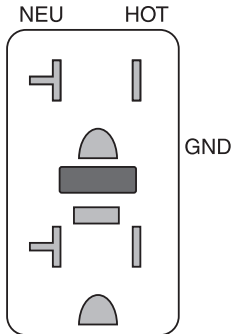

15-20 AMP  
120 VOLT AC

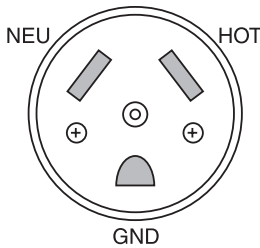

30 AMP  
120 VOLT AC

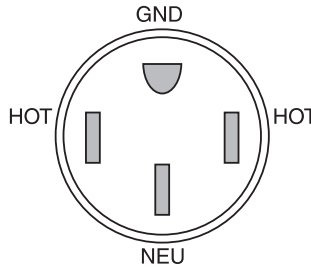

50 AMP  
240 VOLT AC

## Transfer Switch

The transfer switch automatically transfers power from the shore cord, through the transfer switch and to the 110 Volt AC breaker panel. When the generator is used the transfer switch has a time delay built into it. This allows the generator time to warm up before an AC load is applied to it. The transfer switch will automatically select the generator over shore power, even though shore power is hooked up.

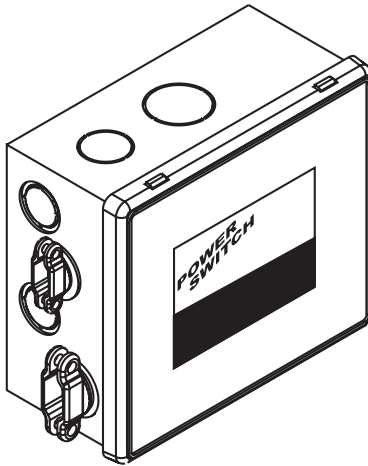

**NOTE:** To prevent damage to the transfer switch do not have appliances on or AC loads plugged into outlets when hooking up to shore power or starting generator. The transfer switch will begin to disengage between 85-90 Volts AC. Operation at this voltage may damage transfer switch, appliances or other items plugged into outlets.



**WARNING:** Keep fingers away from metal contacts of shore plug end. Avoid standing water. Serious electrical shock and personal injury can occur. To avoid the risk of an electrical shock turn the circuit breaker off for the shore power outlet before making shore power connection.

## GENERATOR - 120 AC

The generator is located in the front compartment of the motorhome. The generator can be started from the following locations:

- The generator remote switch, located on the dash.
- The generator control panel, located on the generator.

### Generator control panel:

1. Start/Stop Switch.
2. Hour Meter.
3. Output Breaker.

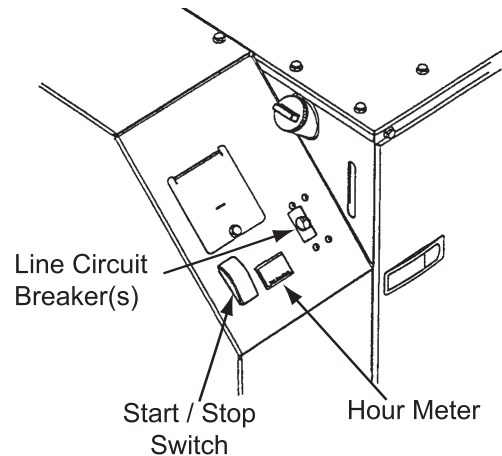

## Prestart checks

Prior to the first start of the day perform a general inspection including oil and coolant levels. Keep a maintenance log on number of hours in operation since the last service. Perform any service or maintenance that may be due.

- People and animals must be clear of hazards of electrical shock and moving parts.
- Appliances and other large AC electrical loads are off.

**Starting the Generator**

Push and hold control switch in START position until the generator starts. Release switch. On diesel models the control switch may flash up to 15 seconds, indicating engine preheat.



**NOTE: Diesel models may require priming. Hold control switch in OFF position for one minute. Repeat if necessary. The diesel generator fuel pick-up tube is cut to approximately 1/4 tank so as not to run the main engine out of fuel.**



**WARNING: Excessive cranking can overheat and damage the starter motor. Do not crank for more than 30 seconds at any one time. Wait at least two minutes before resuming. If the generator fails to start refer to the manufacturer's manual.**



**WARNING: When the motorhome is parked, position the dash air conditioner vent control in the OFF position to prevent outside air from entering the motorhome. The engine exhaust contains carbon monoxide, which is an odorless and colorless gas. Carbon monoxide is poisonous and can cause unconsciousness and/or death. Inspect the exhaust system thoroughly before starting the generator. Do not block the exhaust pipe or situate the motorhome where the exhaust may accumulate either outside underneath, or inside the motorhome or any nearby vehicles. Operate the generator only when safe dispersion of exhaust can be assured. Monitor the outside conditions to be sure that the exhaust continues to disperse safely.**



**WARNING: When parking near high grass be sure that the hot exhaust does not come into contact with the grass, it could be a fire hazard.**

Turn off the appliances and disconnect other AC loads being used. Allow the generator to run unloaded for at least one minute before shutdown. This will allow the engine to cool. Push and hold the control switch in the STOP position until the generator stops. Release the switch.

**Stopping the Generator**

**NOTE: Diesel models require only a momentary stop signal.**

## Powering the Equipment

The AC output of the generator powers the motorhome air conditioners, the AC inverter/converter charger, all appliances and items plugged into the electrical outlets of the motorhome. The number of electrical appliances that can be operated at any given time depends upon how much power is available from the generator. If the generator is “overloaded” or a short circuit causes “over current,” either the generator will shut down or the circuit breaker will trip. If power consumption, in total, exceeds the generator power output compensation for temperature and elevation may be necessary to operate some appliances in sequence, rather than all at the same time.



**NOTE: The generator may shut down when it is loaded nearly to full power and an air conditioner (or other large motor load) cycles on. For a brief moment during start up an electric motor can draw up to three times the rated power. For this reason it may be necessary to operate some appliances in sequence when air conditioners or other large motor loads are on.**

It is important to remember that air density decreases as altitude increases, causing the generator engine power to decrease. Power decreases at approximately three percent of the rated power each 1,000 feet (305M) of increase in elevation above sea level. It may be necessary to operate fewer appliances at the same time when the camping location is at a higher elevation. For example: 7,500 watt generator @ 5,000 ft. = 6,375 watts net. Temperature also affects maximum output watts. For example: @ 120° a 7,500 watt generator produces 6,000 watts net.



**REFERENCE: The diesel generator may shut down for other reasons beside “overloads.” A blink code may appear on the control switch. Refer to the manufacturer’s manual to obtain an explanation of the codes.**

---

## Resetting the Circuit Breaker

If a circuit breaker trips in the main AC breaker panel, or on the generator control panel, there may be a short circuit or too much load.



**NOTE: The generator will continue to run after a circuit breaker trips.**



If a circuit breaker trips, disconnect or turn off as many loads as possible. To reset the circuit breaker switch the circuit breaker to **OFF**; then switch to **ON** to reconnect the circuit. If the circuit breaker immediately re-trips the electrical distribution system has a short or the circuit breaker is faulty. Call a qualified electrician. If the circuit breaker does not re-trip reconnect a combination of loads that will not overload the generator or cause the circuit breaker to trip again. Remember to compensate for elevation and temperature changes when reconnecting loads.



**NOTE: An appliance or load may have a short if it causes a circuit breaker to trip after reconnection. DO NOT continue to reset breaker. Have the problem corrected before resuming operation.**

If use of the generator is infrequent, “exercise” the generator once a month by operating it at approximately half the maximum rated output for two hours. This “exercise” will help promote better starting, more reliable operation and longer engine life. This procedure drives off moisture, relubricates the internal engine parts and replaces the old stale fuel with a fresh supply. It also promotes removing the oxides from the electrical switches and contacts.

### **Generator Exercise**

Use the inverter when shore power is not available and the generator is not going to be used as the secondary AC power source option. This will supply silent AC power to most receptacles, the television and microwave. It is important to remember that use of the inverter will greatly increase house battery power consumption. Turn off the inverter when not in use to conserve house battery power.

#### **To turn inverter on:**

- Turn ON the inverter/converter switch.
- Press the ON/OFF switches on the remote RC9 panel located in the inside overhead compartment next to the entrance door.

### **INVERTER/CONVERTER**

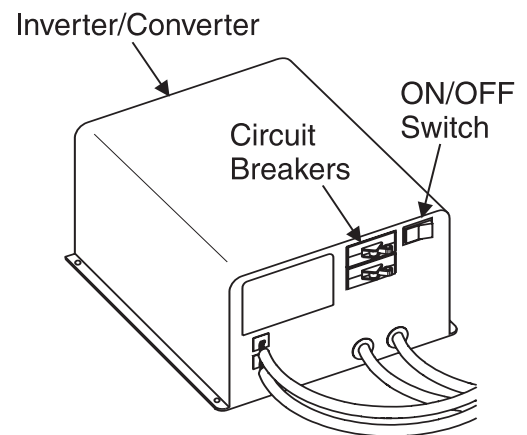

## Operating the Inverter

This section describes the operation of the Trace inverter/charger. The controls on the inverter are very straightforward. They operate exactly as marked on the placard with only a couple of idiosyncrasies.

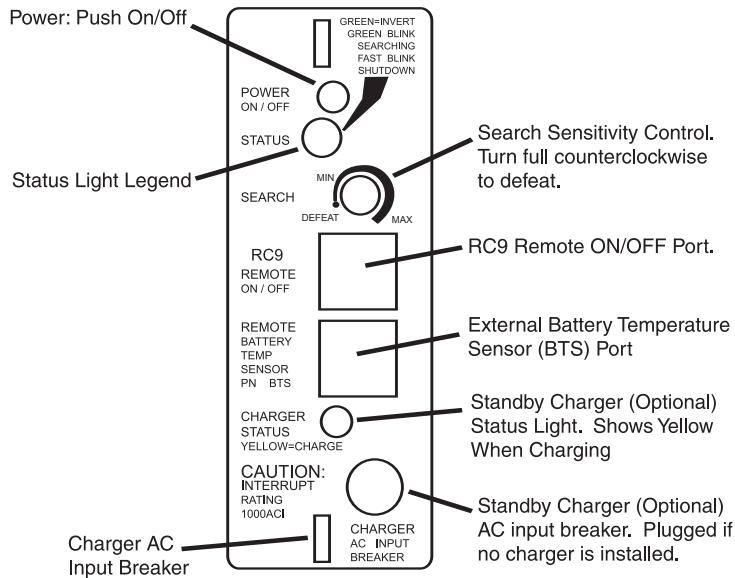

### Control Panel:

The figure to the left shows the control panel located on the left side of the inverter's front panel.

All the information needed to monitor and operate the inverter/charger is listed graphically on the control panel. If the unit does not have the optional standby three-stage battery charger, the charger status light and AC input breaker holes will be plugged.

### Power ON/OFF Button:

This button turns the inverter on and off: **on initial power up press it twice.** The on/off button also resets the inverter in the event it shuts down completely due to a fault condition. To reset the unit after a fault condition, press the on/off button only one time. The on/off button turns off only the inverter portion of the unit. Anytime AC input power is present the battery charger section (if installed) will be operable.

### Green Status LED:

- Steady Green: Unit is in inverting.
- Slow Blinking Green: Unit is in search mode.
- Fast Blinking Green: Indicates error mode. An error condition means a low battery, high-battery, over-heating or over-current condition.

### Search Sensitivity Control:

The knob labeled search sets the threshold (in watts) that will bring the inverter out of search mode. Turning the knob full counter-clockwise to "Defeat" disables the search mode. The adjustment range is 5 to 100 watts (See "Search Sense Mode").

### Yellow Status Led:

If the unit is equipped with the optional Standby Charger, this yellow LED will be lit when the unit is charging. The greater the charging current, the brighter the LED will shine. When battery voltage is far below full charge the LED will glow brightest. When the LED is not lit, battery voltage is higher than both the Absorb and the Float voltage charging threshold or another charger is connected in parallel with the unit.

### **Search Sense Mode:**

The inverter incorporates a power-saving “search Sense Mode” that minimizes power drain when there is no load connected by reducing the inverter’s output to brief test pulses. When a load exceeding the threshold you specify on the control panel is detected, the inverter’s output goes to full voltage. The sensitivity threshold is adjustable from about five watts to 100 watts. When the inverter is in search mode the LED will show a slow flashing green.

### **Search Control Knob:**

The control panel knob labeled “Search” sets the sensitivity level in watts that will activate the inverter. Turn the knob full counter-clockwise to “Defeat” to disable the search mode. The adjustment range is from five to 100 watts.

### **Operation:**

While idling in the Search Sense mode the inverter sends out a pulse about six times per second. This electrical pulse travels through the AC wiring “looking” for loads that are connected to the system. When a load is detected the inverter logic determines the wattage of the load and checks to see if it is greater than the threshold set by the operator. This threshold point is adjustable with the Search Control knob on the control panel. The lowest setting is about five watts and the highest setting is 100 watts.

**For example:** When the search sensitivity threshold is set at 40 watts, and no loads are present that are 40 watts or greater, the inverter will “ignore” any loads less than 40 watts and remain in idle mode. When a load greater than 40 watts appears, the inverter comes out of idle mode and applies power to the load.

The Search Sense mode may be disabled by turning the Search Control knob counterclockwise all the way to “Defeat.” The inverter will now remain at full output voltage at all times.

### **Benefits:**

Search Sense allows you to selectively operate only loads that draw more than a specified amount of power, which means power savings. An inverter consumes about five watts without load idle power consumption of five watts. The inverter needs five watts to power itself, even when there is nothing to power.

**For example:** If a water pump is driven by an inverter for only one hour each day, the other twenty three hours of the day the inverter is consuming five watts per hour just doing nothing. This power comes from the batteries. By setting the search sensitivity so that the inverter idles until the water pump tries to run, power savings are realized.

Instead of idling at five watts, the inverter consumers only one-half watt while in search mode. This is a savings of 4-1/2 watts every hour, or 108 watt-hours per day. This converts directly to 8.6 amp-hours for a 12 VDC battery system. In systems with small batteries or limited charging capability this is a substantial savings.

### **Problem Loads:**

Some loads can “fool” the Search Sense mode causing the unit to cycle on-and-off, or not to turn on at all.

**Incandescent Lights:** Incandescent lights have a higher starting-wattage when the filament is cold than the continuous rating of the bulb. For example: if the inverter is set to sense a 40 watt load, and a 30 watt bulb is turned on, the inverter will initially sense a load because the bulbs cold-starting wattage will exceed the 40-watt threshold. When the bulb warms-up it will draw less than the threshold wattage, the inverter will revert to idle mode and the light will go off. When the light cools, its load will again exceed the threshold and the cycle will repeat.

**Fluorescent Bulbs:** These work the opposite of incandescent light bulbs. If the inverter is set to detect a 30 watt load and a 40 watt fluorescent light is switched on, the inverter will not detect it because fluorescent tubes draw less than 30 watts until the gas in the tube ionizes.

**Other loads:** Some appliances draw power even when turned off. Examples of this are television sets equipped with instant-on circuits, microwaves equipped with digital clocks, VCRs and other clocks. If the search sensitivity threshold is set higher than the combined loads an auxiliary load must be used to bring the inverter out of search mode before the appliances will turn on.

If the sensitivity threshold is set lower than the combination of the load, the loads will run continually, and excess battery drain will occur. Three such 15-watt loads would consume additional 90 amp-hours per 24 hours in a 12 Volt DC system. Some alternatives are: turn the item off at the wall, use an extension cord equipped with an on/off switch, place an on/off switch at the outlet or install an appropriate circuit breaker.

### **Confirming Search Mode Operation:**

A neon-type night light can be used as a test indicator to show whether the inverter is searching for loads. Plug the night light into the wall. If the inverter is in search mode the light will blink, showing the search pulses sent out by the inverter. If the inverter is running a load, the light will be on continuously because continuous power is being delivered to a load. A typical incandescent night light may also work to show the pulses, but it will use more power.

### **Setting Up Search Mode:**

The Search Sense feature significantly reduces battery drain only when the inverter spends a fair amount of time “sleeping” each day. Therefore, if Search Sense is to be utilized it must be adjusted properly. The initial adjustment should be made so that the inverter comes on only when needed.

Determine the smallest load that you want to trigger the inverter out of Search mode. Turn the sensitivity control all the way to the lowest setting, turn on the desired load and turn the sensitivity up until the load just turns on (if loads change significantly, re-tuning of the search sensitivity will be necessary.)

Some TVs have a menu or control to disable instant on circuits. If clocks are a problem load, use battery powered units. A solution might be to place all problem loads on one circuit with one master disconnect.

If problem loads can't be eliminated, disable the Search Sense mode and the inverter will always remain at full output voltage.

### **Configuring Your Charger:**

If your inverter included a Standby Battery Charger it is equipped with three jumpers used to control charger operation. To locate these jumpers, first remove the inverter cover by removing four phillips head screws on top cover and one on back cover above the ventilation slots. The jumpers are close to the top of the circuit board near the front of the unit. These jumpers are located on the main circuit board and are labeled sealed, deep and UPS.

**Sealed:** If you are installing sealed batteries the jumper remains across this pair of pins. This selection sets the charge rate to 14.3 Volt DC in the bulk stage and 13.6 Volt DC in the float stage. For vented batteries remove the jumper across these pins to set the charge rate to 14.7 Volt DC and 13.3 Volt DC respectively.

**Deep:** This pair of pins controls the amount of allowable battery discharge. When the jumper connects these two pins the inverter will allow the batteries to discharge until completely drained. When not installed, the inverter will not allow the batteries to be discharged below  $11.8 V_{DC}$  for more than five minutes (in order to ensure starting-battery capacity).

**UPS:** This pair of pins controls the sensitivity of the charger to variations in voltage from the AC source. When a jumper connects these two pins the charger will stop charging and the inverter will provide AC power within 35 milliseconds or less of an AC voltage drop to below 85-90 volts. With the jumper removed the shift from charger to inverter will be delayed at least 200 milliseconds to allow AC voltage to return to normal. If AC voltage does return to normal within this period the charger will disengage and the inverter (when turned on) will provide AC power from the batteries. This prevents the charger from disengaging unnecessarily due to poor quality voltage. For generator charging, do not connect these pins.

**Troubleshooting  
Inverter/Converter**

SYMPTOM	PROBLEM	REMEDY
No power output and no warning LED's	Battery voltage at the inverter's terminals are too high or low.	Check the battery voltage, fuses or breakers and cable connections.
No power output and LED flashing slowly.	Load too small for Search circuit to detect.	Reduce Search Mode threshold setting or defeat search mode.
Power output LED flashing or erratically.	Overload LED is "ON".	Remove loads from the rapid inverter and restart.
Overheat condition.		Remove loads and let inverter cool down before restarting.
Power output is low and inverter turns loads on and off.	Low Battery.	Check condition of batteries and recharge if possible.
	Loose or corroded battery connections.	Check and clean all connections.
	Loose AC output connections.	Check all AC output connections.
Inverter shuts down after 20 seconds. No LED at all.	Output of inverter is wired back to its own input.	Check for proper AC input and output wiring.
Charger is inoperative.	AC input voltage does not match inverter spec.	Check AC input for proper voltage and frequency for your model, 120 VAC models need >90 VAC to operate.
	Charger voltage improperly set.	Refer to owner's manual for proper setting.
Low charge rate.	Low peak AC input voltage (164 volts peak required for full charger output).	Use larger generator, speed up generator, check AC input wiring, cables too small or long.
	AC current output of generator too small to handle load.	Reduce loads.
Low AC output voltage.	Measuring with the wrong type voltmeter (displays 80-100 VAC).	Voltmeter must be a true RMS reading meter (most are not).
Low surge power.	Weak batteries, battery cables too small or too long.	Refer to cable and battery recommendations in this manual.
Unit overheats.	Unit is Hot.	Let unit cool down, reduce load.
AC lights flicker while charging.	Generator is unstable - charger is losing synchronization.	Reduce loads.

## Battery Charging with the Inverter

Whether hooked to shore power or operating from the generator the internal battery charger of the inverter will automatically charge the batteries when AC power is supplied to the input terminals of the inverter. The time it takes to charge the batteries to a full state of charge varies greatly. It can take several hours or even days, depending on the inverter set-up parameters and actual state of charge of the batteries. The inverter uses a three stage charging cycle. The first stage is “bulk” charge. The “bulk” charge will bring the DC voltage up high, initially between 14.2-14.5 Volts, depending on conditions. The bulk charge cycle is a timed event which the inverter manufacturer has programmed. The second stage is the “absorb” cycle. The battery voltage in this cycle is approximately 14.0 Volts. The length of the absorb cycle will vary with state of charge of the batteries. The final stage is the “float” charge cycle. Approximately 80% of the charging has been completed at this time. The float charge voltage is generally around 13.3-13.7 Volts. The last 20% of the charge cycle of the batteries typically takes the most amount of time.

The charging cycle is repeated each time AC power is discontinued and reconnected. Continuous bulk charging may boil the batteries from a constant higher than normal DC voltage.



**NOTE: The inverter will charge the batteries with AC power applied regardless of remote status.**

### Battery Charger LED Indicator:

A yellow LED located on the lower control panel reports the status of the battery charger.

**Yellow Status LED:** This yellow LED will be lit when the unit is charging. The greater the charging current, the brighter the LED will shine. When battery voltage is far below full charge, the LED will glow brightest.

When the LED is not lit, battery voltage is higher than both the Absorb and the Float voltage charging threshold, or another charger is connected in parallel with the unit.

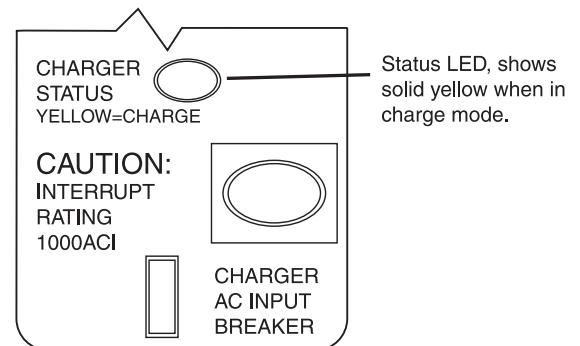

### Generator Requirements:

The maximum charge rate of the battery charger is dependent upon the peak AC voltage available. Because this type of battery charger used only the peak part of the input sine wave, small variation in peak voltage result in large variations in the amount of energy available to the charger. The charger’s output is rated on the basis of typical public power input which has a peak voltage of approximately 164 VAC (116 RMS).



It takes a powerful AC generator set to maintain the full 164 Volt peak while delivering the current necessary to operate the charger at its maximum rate. Smaller generators will have the tops of their wave form clipped under such loads. Running at these reduced peak voltages will not harm the charger, but it will limit the maximum charge rate. Large auxiliary AC loads may provoke this problem.

### Battery Temperature Sensor (BTS)

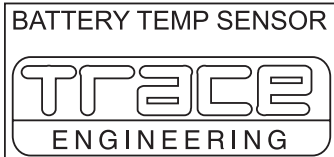

The inverter uses a battery temperature sensor to adjust charge voltage. When the battery temperature rises the BTS will send this information, registering as counts, to the inverter to decrease charge voltage. Voltage compensation with temperature variation is necessary to keep charge voltage at optimum figures. The BTS should be adhered to a house battery. If the BTS is unplugged the inverter default setting of 77° is used as the charge temperature reference point.

### RC-9 REMOTE CONTROL

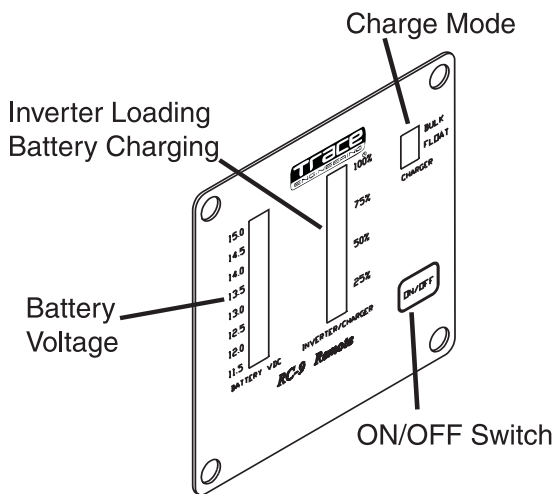

#### Startup and test:

1. Switch the inverter ON using the inverter's front panel ON/OFF switch.
2. Verify the green POWER LED is ON. Verify the BATTERY VDC and INVERTER/CHARGER displays are functioning. Verify that either the BULK or FLOAT LED (In the CHARGER block) is ON.



**NOTE:** When the inverter is plugged into an AC source the CHARGER portion of the INVERTER/CHARGER display is activated. When the AC source is removed and the inverter is running on DC power the INVERTER (LOAD) display is activated.

3. Press the RC-9's ON/OFF switch to turn the inverter OFF. Press it again to restore power and verify correct operation.

### Operation

#### ON/OFF Switch and LED Indicator:

During Normal operation the green LED is ON solid. Press the RC-9 ON/OFF switch to turn the inverter OFF. Press it again to restore power. Whenever the LED flashes slow it indicates the inverter is in "search" mode (looking for a load). If the LED flashes fast it indicates an "error" condition. If any error occurs refer to the inverter's owner's manual for a complete description of the condition.

#### Battery VDC:

The display represents battery voltage in 0.5 Volt increments from 11.5 VDC to 15VDC. Green LED indicate optimum voltage between 12 VDC and 14 VDC. A yellow LED indicates a marginally high battery voltage and comes ON



when the voltage rises to 14.5 VDC. High ( $\geq 15.0$  VDC ) or low ( $\leq 11.5$  VDC) battery voltages are indicated by a red LED.

### Inverter/Charger:



**NOTE: The INVERTER/CHARGER LED display indicates either INVERTER or CHARGER operation. Whenever the RC-9 ON/OFF LED is solid green (not flashing) it indicates the INVERTER display mode is active. Whenever the RC-9 BULK or FLOAT LED is illuminated it indicates the CHARGER display mode is active.**

**Inverter Display Mode:** The display represents inverter loading on a scale from 0 to 100%. The RC-9 automatically calculates the amount of load based on the rating of the inverter (i.e., a 500 VA load on a 1000 VA inverter = 50%; a 250 VA load on a 1000 VA inverter = 25%). All LEDs in the display are red.

**Charger Display Mode:** The display represents battery charging on a scale from 0 to 100%. The RC-9 automatically calculates the charge based on the capacity of the charger (i.e.; 65 AMP charger charging at 65 Amps 100%; 65 Amp charger charging at 32.5 Amps = 50%). All LEDs in the bar graph are red.

### Charge Mode:

**BULK:** The yellow BULK LED indicates the inverter is charging the batteries at a constant current rate, usually after long battery usage. When the battery voltage reaches the inverter's preset limit the charger will move to its next stage of charging.

**ABSORPTION:** The yellow BULK LED then begins to flash slowly, indicating the batteries are being charged at a constant voltage rate (ABSORPTION). As the batteries approach full charge the current supplied to them decreases. The absorption stage is active for a set period and then switches to the final stage of charging.

**FLOAT:** The green FLOAT LED indicates the inverter is maintaining the batteries at a constant voltage level, similar to a "trickle" charge. This ensures the batteries are fully charged without overcharging them.

**DISTRIBUTION  
PANEL -  
HOUSE 110  
AC Panel**

The AC distribution panel is located in the bedroom. The main AC panel 120 Volt circuit breakers receive power from the transfer switch, which is powered by either shore power or the on board generator. Power is introduced into the panel to the 50 amp MAIN breaker first, followed by power being fed to the individual branch circuit breakers. The panel label describes the breaker layout and the item, outlet or appliance to which they pertain.

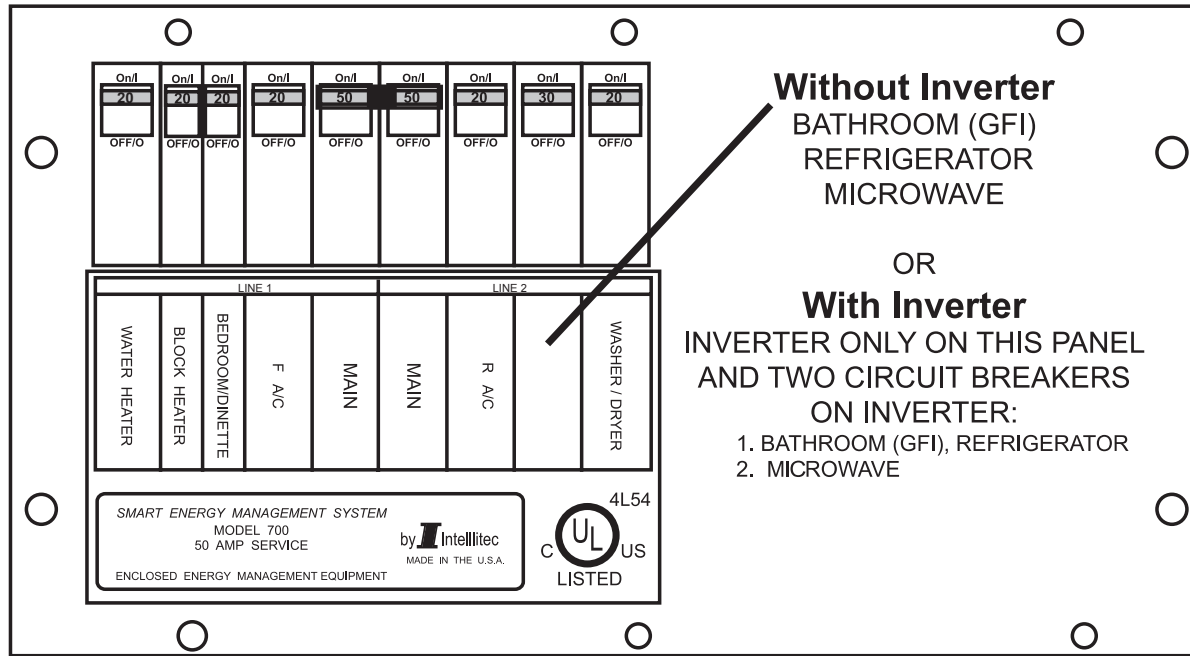

**WARNING:** This panel contains high voltage which can cause serious injury or death. Before beginning any work or testing procedures involving the electric panels, or any of the branch circuits, be sure the motorhome is unplugged from shore power, the generator is not running and the inverter is in the OFF position. Certain testing procedures can require the AC power to be on. Only qualified personnel or personnel with electrical backgrounds should attempt any testing procedures.

Branch circuit breakers supply AC power to the different items or “loads.” An electrical load is any item or device that will use current when supplied with an electromotive force. Should a breaker “trip” from over current use, or a short circuit condition, the load to which the breaker is supplying the electromotive force should be reviewed or disconnected to determine the cause of the trip. If no cause is found, or not readily apparent, reset the breaker by toggling the breaker to the OFF position, then back to ON. Should the breaker trip again after the load is reapplied it may indicate a fault with that particular load. Do not continue to reset breaker until the problem has been correctly diagnosed and corrected.

Breaker current ratings are current set points in which the breaker is designed to operate. The internal configuration of the circuit breaker is designed

to trip when excess current is drawn through the breaker. The trip action of the circuit breaker can occur within milliseconds due to the speed at which electricity can travel. Breaker ratings are set to operate on a continuous load at 80% of the breaker's rated capacity. For example: A breaker with a 20 amp rating will handle a continuous load of 16 amps. This designed set point is when an inductive load is applied, such as when an electric motor turns on. As the motor starts to spin current consumption may momentarily exceed the rated capacity of the breaker. As the electric motor comes up to operating speed the electric motor's current consumption will fall. The AC current load then falls back into the breaker's rated 80% set point. This electric principle should be kept in mind when using anything other than 50 amp shore service and using appliances with electric motors. When using outlets, care should be considered when applying loads such as electric motors, heaters, coffee makers, toasters, hair dryer or other large current consuming loads. If the current rating of a load is not known it is usually stated on most electrical items. The rating will either be in amps or watts. Current ratings stated on electrical items will change slightly with voltage fluctuations. As voltage increases current consumption decreases. This may explain why in some instances items operated at borderline voltage to current tolerances may seem fine in one location, but problematic in another.



**NOTE: To calculate watts to amps, simply divide the watt figure by the voltage of which the item operates from. For example: The electrical item is rated at 1,370 watts. Divide that by the operating voltage of 115 volts which equals 11.913 amps. Use this formula to calculate load to current supply ratio.**

The Energy Management System is easily identified by the remote display panel located in the inside overhead compartment next to the entrance door.

The 50 Amp Smart EMS consists of two elements: the display panel and the bedroom distribution panel. The display panel is mounted in the inside overhead compartment next to the entrance door. The distribution panel, located in the bedroom, is a completely self-contained 120/240 Volt power distribution and energy management system intended to be used in recreational vehicles. It is housed in a sheet metal enclosure with a removable front panel. It provides circuit protection for all the 120 VAC loads in the motorhome and a system of energy management to minimize the over-loading and tripping of circuit breakers.

**Circuit Breakers:** The distribution panel offers slots for eight single or dual, standard 120 Volt circuit breakers. Two of these breakers, located in the two center stab positions, must be a 50 Amp unit that act as a main input protection for each of the lines supplying the remainder of the branch breakers (up to 12).

**ENERGY  
MANAGEMENT  
SYSTEM -  
50 AMP  
(OPTIONAL)**

**Energy Management:** The 50 Amp Smart EMS automatically senses the available power to the motorhome. It determines whether it is connected to a 120 VAC - 30 Amp shore power source, 50 Amp shore power source or generator source. Depending upon available power, it controls the operation of 6 possible loads as indicated on distribution panel. These may be any type load, but are typically heavier loads; those whose use can be “postponed until a time when current is available for their use. If the available power source is 120 VAC - 30 Amp shore power it attempts to keep the total 120 Volt current draw to less than 30 Amps.

**Operation:** If 120 VAC is not available at the distribution panel, L1 or L2 outputs, the system shuts itself off. This feature is intended to prevent the system from drawing current from the +12 VDC battery supply when not in operation.

When 120 VAC power is applied the system automatically powers up and determines the nature of the power source.

If the generator is running 120 VAC will be present at the distribution panel L1 and L2 inputs. In this mode the energy management feature is disabled and all control relay contacts are closed, energizing all of the controlled loads. The control Module sends a signal to the display panel causing the load meter to display actual load current, the GEN SET service indicator to light and all power status indicators to light.

If 120 VAC is present at the distribution panel L1 and L2 inputs the system will assume that 120 VAC, 30 Amp shore power is available and the energy management feature will be enabled. **If only 20 Amp service is available the user must select the 20 AMP service mode by momentarily pressing the 20/30 Amp select switch on the Control Panel.** Initially all relay contacts are closed and the total current is monitored. If the total current should exceed the service limit the system will turn off the first load in the shedding table. As it turns the loads off it calculates the amount of current that was removed, which is the value for that load. This value is placed in memory. If the current remains above the service limit the system will turn off the next load in shedding table. Again, it calculates the amount of current that was removed and places this value, which is the value of that load, in memory. The system continues to turn off loads until the total current falls below the service limit or all of the six controlled loads have been shed. Through this process the system has “learned” the amount of current that each particular load draws. This feature compensates for the differences in current draw over a range of line voltage and ambient temperature, by re-learning the load each time it is turned off or “shed.”

The 50 Amp Smart EMS now wait until the total current is lower than the service limit and enough current is available (as compared with the amount in memory for the last load shed) before it will turn that load back on. This assures that there is sufficient current to operate the load.



**NOTE: There is a two minute minimum delay period after a load is shed before the load will be turned on again to prevent air conditioners from turning on with a head pressure.**

**Three Hour Averaging:** The RVIA (Recreational Vehicle Industry Association) in conjunction with the NEC (National Electrical Council) have established rules regarding the rating of electrical systems and the use of energy management systems. One of these rules requires that if any energy management system is used the average total load current for the system over a 3 hour period be limited to 80% of the service rating. For that reason the 50 amp EMS calculates the average running current for the system and, if it exceeds 80% of the service rating, the EMS sheds loads to reduce the average current below that limit.

For example, if a system operating under 120 VAC, 30 Amp service has been running at the 30 Amp limit for three hours, the EMS will change its shedding threshold to 24 Amps and turn off loads until the 24 Amp limit is attained. If the user selects the 20 Amp service mode this limit will translate to 16 Amps. Because the EMS calculates a running 3 hour average, if the average load current drops below the limit the system will restore power to loads based on their impact on the limit. If the system is in the averaging mode the decimal point at the lower right corner of the load meter display on the display panel will illuminate.

**Display Panel:** The display panel is located in the inside overhead compartment next to the entrance door and connects to the distribution panel located in the bedroom. Six power status LEDs indicate power is applied to those loads. These LEDs are on when the power is applied. The load meter has a two digit display to indicate the amount of current actually being drawn by all the appliances in the motorhome.

Four service type LEDs indicate the source for 120/240 VAC power. Three of these sources are automatically detected and indicated by the EMS, namely: Gen Set Service, 50 Amp Service and 30 Amp Service.

**The 20 Amp service mode is not automatically detected and the operator must manually select the 20 Amp mode when 20 Amp service is available.** The service select button allows the current threshold to be set to either 30 Amps or 20 Amps to match the incoming service.

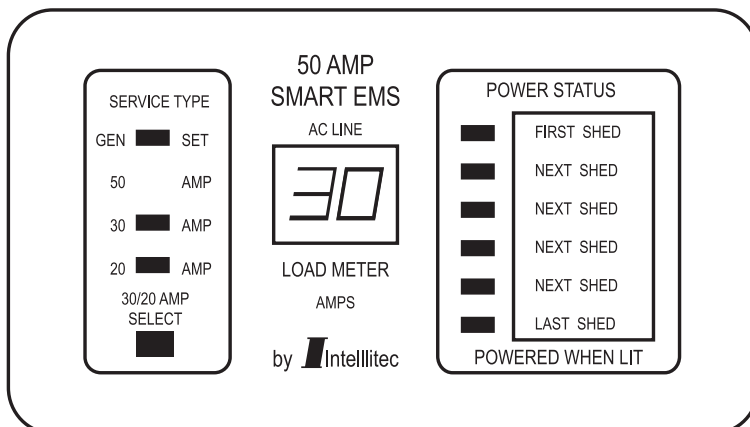

## DISTRIBUTION PANEL - HOUSE 12 VOLT

The 12 Volt house contains fuses (located in the bedroom overhead cabinet) that protect the electrical circuits. These fuses are the standard automotive type. When a fuse is “blown,” the wire in middle of the plastic case will be burnt. A broken, bad or “blown” fuse must be replaced with a fuse of the same rating and type. Use of a fuse with a different rating or type will defeat the circuit protection provided by that fuse and could result in damage to the motorhome’s electrical system.

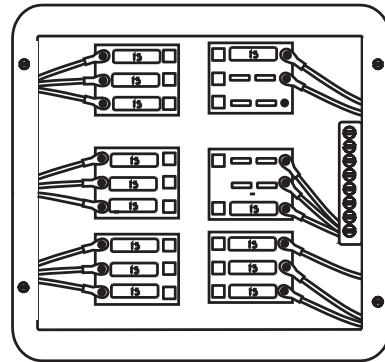

- |                 |                 |
|-----------------|-----------------|
| #-COLOR-AMP     | CIRCUIT         |
| 1 - BLUE - 15   | BATH LTS/VENT   |
| 2 - YELLOW - 15 | DIN,PRCH,R O/H  |
| 3 - GREEN - 15  | BEDROOM LTS     |
| 4 - VIOLET - 15 | VENTS, L O/H    |
| 5 - RED - 15    | CEILING LTS     |
| 6 - GRAY - 15   | FURNACE,A/C 12V |
| 7 - RED/T - 15  | MONITOR PANEL   |
| 8 - BLACK - 15  | SLIDE-OUT       |
| 9 - GRAY - 5    | RADIO           |
| 10 - RED - 15   | ELECTRIC AWNING |
| 11 - RED - 15   | COMPUTER TABLE  |
| 12 - BROWN - 15 | POWER TOILET    |

### Fuses

AMPERAGE	COLOR
1	BLACK
2	GRAY
3	VIOLET
4	PINK
5	GOLD
7.5	BROWN
10	RED
15	BLUE
20	YELLOW
25	CLEAR
30	GREEN

Amperage Chart

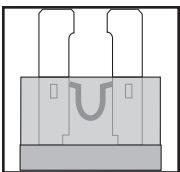

ATO Fuse

The 12 Volt fuses, located in this distribution panel, service the interior house lighting, ventilation fans, monitor panel, furnace and water heater. Should a fuse blow it will be evident by the broken metal strip located in the center of the fuse. Replacement fuses should be of the same amperage. If a higher rated fuse is installed it can damage the wiring. Fuse current set points follow much of the same electrical principle as the 120 Volt AC breakers. Using 12 Volt DC as the electromotive force can make it more susceptible to outside influences, such as corrosion from weathering or oxidation.

The large variety of applications this voltage can be used in makes it a diet staple for most of the recreational vehicle and automotive industries. The danger from shocks with this voltage is minimized, but can still occur. A good example is when a magnetic field is generated, then collapses when the power supply is cut. The result is a discharge that can reach tens of thousands of volts for a short time period. Care should be used when working with this voltage as current values can be quite high, like in the case of battery cables.

Shorting a battery cable to ground with a battery at a reasonable state of charge can result in a fire or serious personal injury from a burn.

### Tools of the Trade

One of the most widely used tools for testing a 12 Volt problem is the test light. Test lights come in a host of varieties, such as a light bulb with a probe and ground clip, to the more elaborate electronic ones that measure a wide scale of voltages and perform a variety of functions. A VOM or Volt Ohm Meter is used to perform a multitude of tests. It is generally used when exact values are needed for evaluation. These meters come in an analog or digital format. Either



of these two testing tools may be used, depending upon personal preference. If a 12 Volt light is not working, the test light may be better suited for this. In the case of a charging system problem the meter may be the tool of choice. In any situation the testing tool is an invaluable piece of equipment when it comes to determining an electrical problem.

Should it become necessary to use testing tools take certain precautions and consider three things. First, recognize when the problem is beyond your skill level. Nothing will create more mayhem than being armed with tools and going in an unknown direction. Good intentions have led to major problems. The second item to keep in mind is if something will cause more grief by being dealt with now than if it were left alone and repaired by a professional at a more convenient time. How many times have you said to yourself, “Oh this will only take a few minutes,” only to find it is taking an entire day and you wished you had not touched it. The third item to consider is whether or not the current situation may be potentially dangerous if left to be repaired at a more convenient time?

### **Know When to Say No**



**NOTE: Check all related fuses before assuming you have encountered an electrical problem or situation. Spare fuses should be kept on hand and can be purchased from an auto parts stores. A fuse description label is on the distribution panel cover.**



**WARNING: If a fuse blows replace the fuse with same amperage rating and type. Installing higher amperage fuses can damage the wiring or the item the fuse is protecting, or may cause a fire. If the fuse repeatedly blows after replacing it do not continue to replace it. Have the problem diagnosed and corrected by a qualified technician.**

The operation of the battery is based on a chemical reaction. The battery is comprised of lead plates and a solution of distilled water and sulfuric acid. The solution, when mixed together, is known as “electrolyte.” The 12 Volt battery is actually six batteries in one case. When charged, each cell has a voltage of 2.1 Volts. When six cells are hooked together this makes a 12.6 Volt battery (fully charged).

### **BATTERY - HOW IT WORKS**

Electrons are stored on the negative plates. When a load (eg. a light bulb) is put between the positive and negative terminals, the electrons move from the negative plate to the positive plate through the “load” and then back to the ground terminal. At this time the sulfuric acid leaves the water and adheres onto the plates of the battery. The electrolyte solution keeps the electrons from flowing while the battery is in the “at rest” position.

Charging the battery moves the sulfuric acid back into solution with the distilled water. A battery left in a low or discharged state will cause the acid to

“sulphate.” In attempting to recharge the battery the acid has become hardened and no longer will leave the plates and enter into the liquid solution with the distilled water. The lowered acid to water ratio has a direct affect on the battery’s ability to release the stored electrons (power output) and the length of time it can perform (reserve capacity). Batteries left in a discharged condition will readily freeze. This can crack the case allowing the solution to spill; it can also warp the plates. The acid acts like an “antifreeze” for the battery. This is why batteries should not be left or stored in a “discharged” condition.

---

### **Battery Types**

Batteries come in different sizes, types, amp hours, voltages and chemistries. There are nearly as many descriptions of battery types and how they should be used as there are people willing to offer advice on them. Although it is not possible to cover batteries in their entirety, there are guidelines that can be followed to ensure that the batteries are well maintained.

---

### **Starting Battery**

Starting batteries are designed for high output cranking power, but not for deep cycling like the house batteries are designed to do. Starting batteries will not last long in deep cycle application. The way they are rated should give a good indication of their intended use. “Cold Cranking Amperage” is a measurement of amperage output that can be sustained for 30 seconds. Starting batteries use thin plates to maximize the surface area of the battery. This allows a very high starting current, but lets the plates warp when the battery is deep cycled (discharged).

---

### **Deep Cycle Battery**

This is the type of battery that is best suited for use with 12 Volt operated lights, appliances and inverters. Deep cycle batteries are designed to have the majority of their capacity used before being recharged. Available in many sizes and types, the most common is a non-sealed, liquid electrolyte battery. The non-sealed types have battery caps. The caps should be removed periodically to check the level of electrolyte. When a cell is low only distilled water should be added. Water consumption will vary depending on many factors: how far the batteries are depleted, how much voltage, how long the voltage is being applied to charge the batteries and how often this occurs.



**NOTE: Tap water contains minerals which can alter battery chemistry and ruin the battery. Use only distilled water when refilling the battery.**

---

### **Battery Maintenance**

At a minimum, the battery electrolyte level should be checked at least once a month. Check the level sooner if the battery is frequently used. The level should be above the top of the plates, but not overfull. Most batteries have a plastic cup or well. The electrolyte level should be approximately 1/8” below the well to allow room for expansion while the battery is being charged. Overfilling the battery will allow the electrolyte solution to boil or gas out of the battery cap. Remember to use only distilled water to refill the battery. A battery



with a low electrolyte level will boil the water out rapidly once the plates have been exposed to air. This process may take only a matter of hours. If this has happened the battery is more than likely damaged.

After checking the battery's electrolyte levels it is also a good idea to check the battery connections for tightness and corrosion. If any corrosion is found, disconnect the cables (make sure to mark their locations) and carefully clean them with a mild solution of baking soda and water. There are also aerosol products available that will work. This will neutralize any acid that may be present. Do not allow the solution to enter the battery as this will damage the electrolyte balance. Use water to rinse the top of the battery area when done. Hook the cable back to the battery. Coat the terminals with petroleum jelly or an anti corrosion grease.

The battery cable to battery terminal connections should be metal to metal. Periodically check the batteries for corrosion. Look for cracks and check the vent plugs. Replace them if they are cracked or missing. Keep the top of the batteries clean. The accumulation of electrolyte and dirt may permit small amounts of current flow between the terminals, which can drain the battery.



**WARNING: Liquid lead acid batteries produce hydrogen gas while being charged. This is highly explosive. Do not smoke around batteries. Extinguish all flames in the area. Batteries may explode resulting in fire, personal injury, property damage or death.**

The engine (chassis) and domestic (house) batteries are located in a curb-side compartment. The slide-out battery trays are secured in place by a locking mechanism at the front of the trays. To slide the tray out lift up on the handle and pull until the tray stops. To re-secure the battery tray push it back in until the tray latches.

The battery tray slides will occasionally need to be lubricated. When performing maintenance to the batteries clean the old lubricant and dirt from the battery tray slide with solvent, brake cleaner or equivalent. Do not allow any of the cleaning solution or battery acid by-products to spatter onto the painted surfaces. Damage to the paint surface will result. Lubricate all moving parts of the battery tray slide with white lithium grease or Kwikiee brand spray lubricant.



**NOTE: Driving without the tray secured can result in damages.**



**CAUTION: Many types of petroleum based products or battery by-products can damage the paint finish. Do not allow these types of chemicals to get on the paint finish. If the chemicals do get on the painted surfaces immediately rinse the surface using plenty of water with a mild automotive detergent.**

### Battery Trays

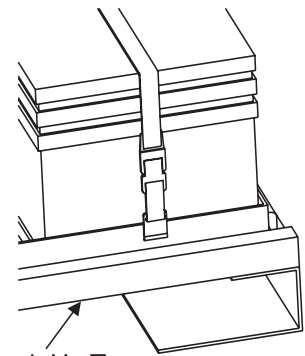

Move Lock Up To Release Tray

## Testing the Battery

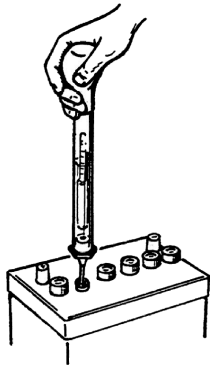

The only way to test a battery's electrolyte solution is with a hydrometer. Many styles are available, from types with cylinder graduation (shown here) to types with floating balls. Hydrometer can be purchased from most auto part stores. The hydrometer tests the battery's electrolyte solution which is measured in specific gravity (sulfuric acid to water ratio). Distilled water has a specific assigned gravity of 1,000. The hydrometer is calibrated to this mark. Pure sulfuric acid has a specific gravity reading of 1,840. The acid is 1.84 times heavier than water. The electrolyte solution is about 64% water to 36% acid (fully charged battery). Hydrometer's with cylinder graduation are graphed and the exact state of specific gravity can be determined.

Temperature and recent battery activity (charging or discharging) affect the hydrometer readings. It is best to check the battery when it has been "at rest" for at least three hours, although readings taken at other times will give a "ball park" figure. Using the hydrometer, draw the electrolyte solution up into the tube. Allow the hydrometer to attain the same temperature as the electrolyte solution. Note the reading for that cell. Complete the same test for the rest of the cells on that battery tank.

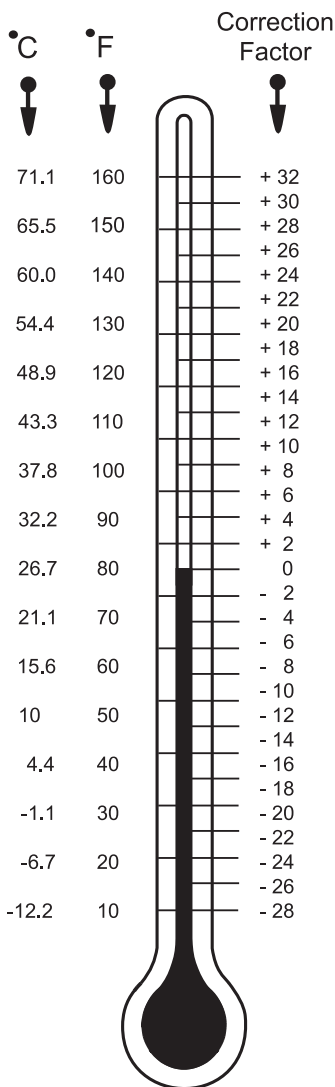

Temperature

Chart readings are taken at 80° Fahrenheit. Temperature affects the hydrometer readings. The higher the electrolyte temperature, the higher the specific gravity reading. The lower the temperature, the lower the specific gravity reading will be. Add or subtract four points for each 10° variance from the 80° Fahrenheit chart. Readings between cells should not vary more than 50 points.

If one cell in a particular battery bank being tested is at a 50% state of charge while the others are fully charged, charge that battery to see if the low cell will come up. At the same time, do not over charge the "healthy" cells.

If the low cell does not come up after charging, this battery can damage the rest of the battery bank and should be replaced. An accurate digital volt meter + .5% will also give an indicator of the battery's state of charge.

Another test that can be performed is to put the battery under a specified load for a predetermined length of time for that particular battery's rating. This machine is usually an adjustable carbon pile that can vary the load applied to the battery while monitoring voltage to see if they will perform to the specific rated capacities.



**NOTE:** See chart for temperature compensation. Liquid levels should be even between the cells of the battery being tested as it will affect the accuracy of the test.



**WARNING:** Sulfuric acid in the batteries can cause severe injury or death. Sulfuric acid can cause permanent damage to eyes, burn skin and eat holes in clothing. Always wear splash-proof safety goggles when working around the battery. If battery electrolyte splashed in eye or on skin, immediately flush the affected area for 15 minutes with large quantities of clean water. In case of eye contact seek immediate medical aid. Never add acid to a battery once the battery has been placed in service. Doing so may result in hazardous splattering of electrolyte.

**Seven Reasons Why Batteries Fail**

**1. Physical Condition:** Active material flakes off the plate and falls to the bottom of the cell. This is normal, but sediment accumulates under the plates and can short out a cell. The plate separators fail to insulate positive and negative plates in a cell and the cell becomes shorted, ruining the battery.

**2. Insufficient Electrolyte:** This allows exposed portions of the plates to sulfate rapidly. This reduces the battery's ability to accept a charge and the battery capacity is reduced. Accelerated erosion of the lower portions of the plates occur from higher than normal acid content due to water loss. Only the water evaporates, not the acid. This battery also has a higher internal resistance when low on water. Add only distilled water. Fill each cell to the bottom of the vent well when the battery is warm. Filling a very cold battery with water to the bottom of the vent well will cause overspill when the battery warms up and the plates expand. A Battery Formula For Failure: the battery has a higher internal resistance when low on water, therefore: *high resistance = more heat shorter battery life!*

**3. Sulfation:** When a battery is allowed to remain discharged too long the accumulated lead sulfate in the plate material solidifies and cannot reenter the electrolyte. Sulfate in plates is not able to reconstitute the electrolyte to a higher specific gravity, or to restore the plate material to a more active composition.

**4. Oveheating:** A battery operated, when the electrolyte temperature reaches 125°F, increases the chemical reaction. This increases the corrosion of the plates and reduces the battery life. When oveheated the battery plates tend to buckle and destroy the a structural integrity of the battery.

**5. Freezing:** When the electrolyte freezes, ice formed dislodges the active material from the plates. The battery case may crack and the electrolyte will leak out when thawed. It is especially important to keep a battery at full charge in cold weather to prevent freezing. The high specific gravity of a fully charged battery does not freeze as easily. Never attempt to recharge a frozen battery. Warm it up first.

**6. Corrosion:** Corrosion from spilled or splashed electrolyte form deposits that can conduct electricity and cause battery drain. Clean off all corrosion, especially around the battery terminals and on the top cover of the battery. Prevent accumulation by coating the terminals and the exposed metal cable connectors with high temperature grease.

**7. Overcharging:** Overcharging rapidly converts water to gas and decreases the electrolyte's water content as the water evaporates. The electrolyte level drops and becomes more acid in content. This subjects the plates to a higher concentration of sulfuric acid and results in early battery failure.



**NOTE: Any time you add more than one or two ounces per cell per-thousand miles driven, check the motorhome charging system for overcharging. Prolonged overcharging generates excessive heat inside the battery, which buckles the plates and destroys the battery. It is a fact that over 50% of battery failures are caused by overcharging.**

---

## **Battery Voltage & Current**

Why does the voltage on a discharged battery measure the same as a fully charged battery until the loads are applied? The simple answer to this might go as follows: A battery creates electrical power by converting energy from a chemical reaction into a electrical energy. As this reaction slows down, the battery voltage will drop. In a lead acid battery the electrolyte conductivity (how well electrical current can flow through it) changes. The same current may be available but the rate of the reaction decreases, causing a voltage drop.

Another way of looking at this is to use the analogy of a water pump (a battery is an electric pump). The pressure in PSI (pounds per square inch) that a pump delivers is like a battery's voltage. The volume of water in GPM (gallons per minute) is like the electrical current. Let's look at a 12 PSI pump with no loads (the pump is running but the outflow valve is turned off). The pump will run and the internal pressure of the pump will build up to some point higher than 12 PSI. Once the valve is opened and the water is free to flow into the loads the pressure will drop to the rated output pressure of 12 PSI, but only if the load is not too big. If the pump is designed to maintain 12 PSI at 15 GPM, and a load demanding 20 GPM is connected, the pump will not be able to keep up and the pressure will get sucked down to a lower PSI. If the load is then reduced or removed, the pump will catch up and return to its rated 12 PSI pressure. If the pump never runs out of pressure, and is operated at or below its 15 GPM level, it will hold 12 PSI. However, a pump that is connected to a water tank with a finite capacity will start to lose the ability to hold pressure as the level of water in the tank drops. Think of siphoning water from a bucket. As the level of the water drops, the volume of water exiting the siphon slows down.

When the tank is full it is capable of feeding more pressure to the pump inlet due to gravity and the pump always has enough water available to maintain its rated pressure and volume. However, if the water tank gets low the pump will not have water volume coming in to maintain 12 PSI at 15 GPM. If the loads are taken away from the pump by closing the valve on the outflow, even with low pressure in the tank the pump will eventually pump up to 12 PSI. It will just take it longer to get there. When the valve is opened the pump will sustain 12 PSI for a brief period, but since the tank is no longer feeding the pump as fast as needed the pressure will eventually drop. This analogy can be

restated by replacing the pump with a battery, pressure with voltage, volume with amps, outflow valve with a switch, water with electricity and the water tank with the battery electrolyte.

The level of the tank could be thought of as the rate of the reaction taking place in the electrolyte. When the battery is fully charged the electrolyte has an excess of reactions taking place to feed the battery terminals. This tapers off with time as the electrolyte is spent so maintaining voltage becomes possible. With no loads the spent electrolyte will be capable of producing close to the rate voltage, but only after a period of time has elapsed for enough reactions to take place to bring the voltage back up. Hopefully, this scenario will help make clear why a battery measured at rest can show close to its rated voltage but will not run a load.

**Calculating Run Times:** Calculating run time figures when operating 120 Volt AC electrical items with an inverter can be expedient. This is due to battery characteristics. Flow characteristics of electrons vary with different battery type and chemical compositions. Deep cycle batteries are generally designed to slowly release a majority of their charge capacity. Deep cycle batteries are rated in amp hours (Ahrs) with the discharge occurring over an extended period of time before the battery is charged. Engine starting batteries are designed to quickly release large amounts of current for short durations, without depleting battery reserves. Commercial type batteries bridge the gap of deep cycle and engine batteries. Commercial batteries release medium amounts of current over a longer period of time, but they are not designed to cycle their charge capacity.

### **Battery Charge Time & Consumption Rate**

The working range of a deep cycle battery is between 50 and 100% state of charge (SOC). Deep cycle batteries should not be cycled below 50% state of charge. Discharging a deep cycle battery below 50% state of charge shortens the life of the battery. Deep cycle batteries use an amp hour rating which is usually calculated over a 20 hour discharge interval. Example: A deep cycle battery with a rated capacity of 100 Ahrs is designed to release current at the rate of five amps per hour. Multiply a 5 amp load over a 20 hour discharge period equals the rated 100 Ahr capacity. These discharge figures are calculated with the battery starting at 100% state of charge with the battery at 80° Fahrenheit when the discharge cycle begins. However, increasing the discharge load applied to the battery five amps to ten amps on a 100 Ahr battery does not yield 10 hours of discharge time. This is due to the internal reactions which occur when a battery is discharging. Actual discharge time for a 10 amp load may be closer to eight hours of discharge time. Increasing the load applied to the battery to 20 amps will not yield five hours discharge time but may be less than three hours. It might be understood as a point of diminishing return.

Calculating applied loads to an inverter to approximate run time from the battery amp hours available is not an equal trade up when voltage is inverted and amperage is calculated. When the inverter is used to operate an AC load it



uses approximately ten times the DC current needed from the battery when inverting 12 Volts to operate the 120 Volt item. Also, a small inverter loses approximately 10% of its efficiency when inverting. For example: When using the inverter to operate an AC electrical item, which has a current draw rating of 2 amps, the inverter will use over 20 amps DC power from the batteries.

**Determining Current Consumption** First determine the amount of current used by an AC item. For example: The television is rated at 200 watts at 120 Volts. Calculate watts to amps. Divide 200 watts by the operating voltage of 120, this equals 1.6 amps. Multiply 1.6 amps AC current by a factor of ten the inverter will use. This equals 16 amps DC battery current. Add the revised 10% efficiency loss figure. This calculates to a total of 17.6 amps DC. If the battery bank capacity is rated at 50 Ahrs actual elapsed time to the suggested 50% state of charge would net viewing time for the television at approximately 13 hours in ideal conditions.

The run time figure will vary greatly with the actual state of charge of the battery bank when the discharge process begins. Ambient temperature, combined with other working loads such as lights and parasitic loads applied to batteries, affect run times. Calculating the exact run time is not precise due to all the variables and equations involved; however, an approximate time figure can be obtained. Proper battery maintenance and charge cycles affect battery performance. Observe the battery condition with hydrometer and voltage readings. Use only distilled water when filling batteries. To achieve the highest quality of battery performance and longevity keep batteries in their proper operating range.

---

**Battery Specifications**

<b>Chassis</b>	<b>Ah (20hr)</b>	<b>CCA</b>	<b>RC (25A) minutes</b>
<b>12 Volt Chassis</b>			
<b>8D-MHD (1)</b>	<b>240</b>	<b>1400</b>	<b>450</b>
<b>6 Volt Domestic</b>			
<b>U2200 (4 each)</b>	<b>225</b>	<b>**</b>	<b>447</b>

Battery connections are made in a Series/Parallel connection. Domestic batteries not rated in Cold Cranking Amps (CCA).

STATE OF CHARGE	VS	OPEN CIRCUIT	STATE OF CHARGE	VS	SPECIFIC GRAVITY
100%		12.66V	100%		1.265
75%		12.45V	75%		1.225
50%		12.24V	50%		1.19
25%		12.06V	25%		1.155
Discharged		11.89V	Discharged		1.12

CUMMINS ENGINE COLD CRANKING AMPS REQUIREMENTS						
	ISB	1100	CCA	12 VOLTS		
	ISC	1250	CCA	12 VOLTS		
	ISM	1800	CCA	12 VOLTS		
	N14	1800	CCA	12 VOLTS		

**BULB USAGE - INTERIOR**

INTERIOR BULB CHART	
LOCATION	BULB NUMBER
CEILING LIGHT	GE F15T8-CW
CLOSET LIGHT	SYLVANIA 1141
BEDROOM OR LIVINGROOM LAMP	SYLVANIA 1076
PORCH LIGHT	SYLVANIA 921 GE 92

**NOTES**



# Diplomat

## SECTION 9 ELECTRICAL SYSTEMS - CHASSIS

<b>INTRODUCTION</b>	<b>• 197</b>
<b>BATTERY DISCONNECT - CHASSIS</b>	<b>• 197</b>
<b>BATTERY CHASSIS</b>	<b>• 198</b>
<i>Battery Specifications - Chassis</i>	<i>• 199</i>
<b>DASH</b>	<b>• 200</b>
<i>Indicator Lamps</i>	<i>• 200</i>
<i>Gauges - Dash</i>	<i>• 202</i>
<i>Switches - Dash</i>	<i>• 204</i>
<i>Air Conditioner &amp; Heater Controls</i>	<i>• 206</i>
<b>DIAGNOSTIC PLUG LOCATION</b>	<b>• 214</b>
<b>SHIFTER PANEL</b>	<b>• 214</b>
<i>Switches</i>	<i>• 215</i>
<i>Parking Brake</i>	<i>• 218</i>
<b>STEERING COLUMN</b>	<b>• 218</b>
<i>Tilt &amp; Telescope</i>	<i>• 218</i>
<i>Hazard Flasher</i>	<i>• 218</i>
<b>FUSES &amp; CIRCUITS - CHASSIS</b>	<b>• 219</b>
<i>Distribution Panel - Front</i>	<i>• 219</i>
<b>ALTERNATOR</b>	<b>• 221</b>
<i>Check Out Procedure</i>	<i>• 222</i>
<i>Battery Maintainer</i>	<i>• 223</i>
<b>BULB USAGE - EXTERIOR</b>	<b>• 224</b>



## **INTRODUCTION**

A majority of the lighting and appliances are designed to operate from 12 Volt DC (direct current) power. This is why the batteries play such an important role in the function of the motorhome. There are exceptions with appliances such as the microwave or television; however, indirectly they still operate from 12 Volt DC power, as they can be operated from the inverter. The chassis functions (engine, transmission, dash air, etc.) are also 12 Volt DC.

With the all technological advancements taking place in the past several years manufacturers have now incorporated electronics into these systems. It is important to keep the 12 Volt system(s) in good working order. These systems, with their incorporated electronics, are voltage sensitive. Some items can be damaged if the DC voltage is not maintained within the designed specifications.

There are two separate 12 Volt systems. One is the chassis system; the other is the house system. These two systems, for the most part, are separate from one another. The house system does not operate engine functions; as the engine system does not operate house functions. However, within the two systems there are some inner connections. For example: While the motorhome is driven the alternator on the engine will charge the house batteries. Likewise, while the motorhome is plugged into shore power or the generator is running the engine battery(s) are being charged. Each system will supply 12 Volt DC power to the 12 Volt distribution panels. The 12 Volt panel that services a majority of the chassis system functions is located outside by the driver's front wheel. The other panel, located in the bedroom, services the house interior functions such as the interior lighting and appliances. You should become familiar with these panels and the items they operate.

The two different systems, engine and house, have their own set(s) of battery(s). The engine battery supplies 12 Volt DC power to the front distribution panel located in an outside compartment by the driver's side front wheel. This panel contains mostly engine system fuses and wiring such as headlights, taillight, dashboard functions, gauges, etc. The house battery(s) supplies 12 Volt DC power to the distribution panel located in the bedroom. This panel contains fuses for the house, interior lighting and appliances, such as the furnace and water heater.

The main battery disconnect for the chassis battery turns the DC power on or off to the rear and front run boxes. Most chassis and engine functions are interrupted when the battery disconnect is turned off. Some electronic items require a constant power source for memory retention such as the dash and CB radios. Some electronic components of the engine and transmission require a constant power source. Turn the main battery disconnect switch off when the motorhome is going to be stored or performing electrical maintenance. If possible, leave the motorhome plugged into an AC source with the battery discon-

**BATTERY  
DISCONNECT  
- CHASSIS**

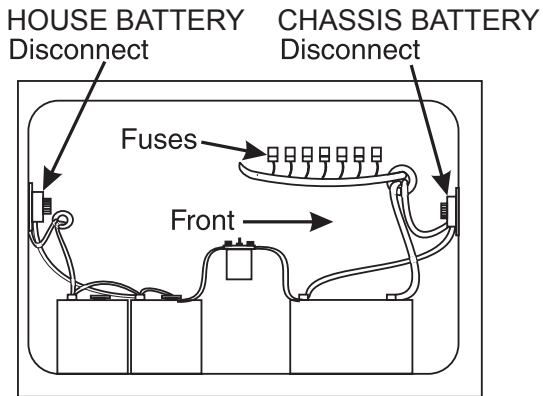

nect switch on. This will help prevent the possibility of dead batteries. If an AC source is not available and the motorhome is not going to be used or is stored more than 48 hours it is recommended to turn the battery disconnect switch off.



**WARNING:** When the frame or other welding is involved for motorhome repair or modification the following precautions are required to protect electronic components in the motorhome chassis:

1. Disconnect the (+) positive and (-) negative battery connection and any electronic control ground wires connected to the frame or chassis.
2. Cover electronic control components and wiring to protect from hot sparks.
3. Disconnect the wiring harness connectors at the transmission electronic control unit. Open bed storage compartment, open engine access door. The ECU is located above the transmission.
4. Do not connect welding cables to electronic control components.
5. The welding ground cable should be attached no more than two feet from the part to be welded.

## BATTERY - CHASSIS

The chassis battery operates only chassis and engine functions. The chassis battery is a crank type battery, producing the high amperage needed to start the engine. Engine starters initially require a large amount of current to crank an engine. Initial starter amperage draw exceeds 1200 amps. The type of application in which the engine battery is used differs from the house battery application. The engine battery state of charge remains consistent. Maintenance is still required with an engine battery. Regular electrolyte level checks and hydrometer readings should be performed. High electrolyte consumption or inconsistent hydrometer cell readings may indicate a charging system problem. Perform a charging system and current draw check if the battery is exhibiting abnormal hydrometer readings.



**NOTE:** Replacement batteries should have the same cold cranking amp (CCA) rating.

**Battery Specifications - Chassis**

<b>Chassis</b>	<b>Ah (20hr)</b>	<b>CCA</b>	<b>RC (25A) minutes</b>
<b>12 Volt Chassis</b>			
<b>8D-MHD (1)</b>	<b>240</b>	<b>1400</b>	<b>450</b>
<b>6 Volt Domestic</b>			
<b>U2200 (4 each)</b>	<b>225</b>	<b>**</b>	<b>447</b>

Battery connections are made in a Series/Parallel connection.  
Domestic batteries not rated in Cold Cranking Amps (CCA).

<b>STATE OF CHARGE</b>	<b>VS. OPEN CIRCUIT VOLTAGE</b>
<b>100%</b>	<b>12.66v</b>
<b>75%</b>	<b>12.45v</b>
<b>50%</b>	<b>12.24v</b>
<b>25%</b>	<b>12.06v</b>
<b>Discharged</b>	<b>11.89v</b>

<b>STATE OF CHARGE</b>	<b>VS SPECIFIC GRAVITY</b>
<b>100%</b>	<b>1.265</b>
<b>75%</b>	<b>1.225</b>
<b>50%</b>	<b>1.190</b>
<b>25%</b>	<b>1.155</b>
<b>Discharged</b>	<b>1.120</b>

**CUMMINS ENGINE COLD CRANKING AMPS REQUIREMENTS**

ISB 1100 CCA 12 VOLTS  
 \* ISC 1250 CCA 12 VOLTS  
 ISM 1800 CCA 12 VOLTS  
 N14 1800 CCA 12 VOLTS

CCA Rating are at 0° F. These are the minimum requirements.

## DASH - Indicator Lamps

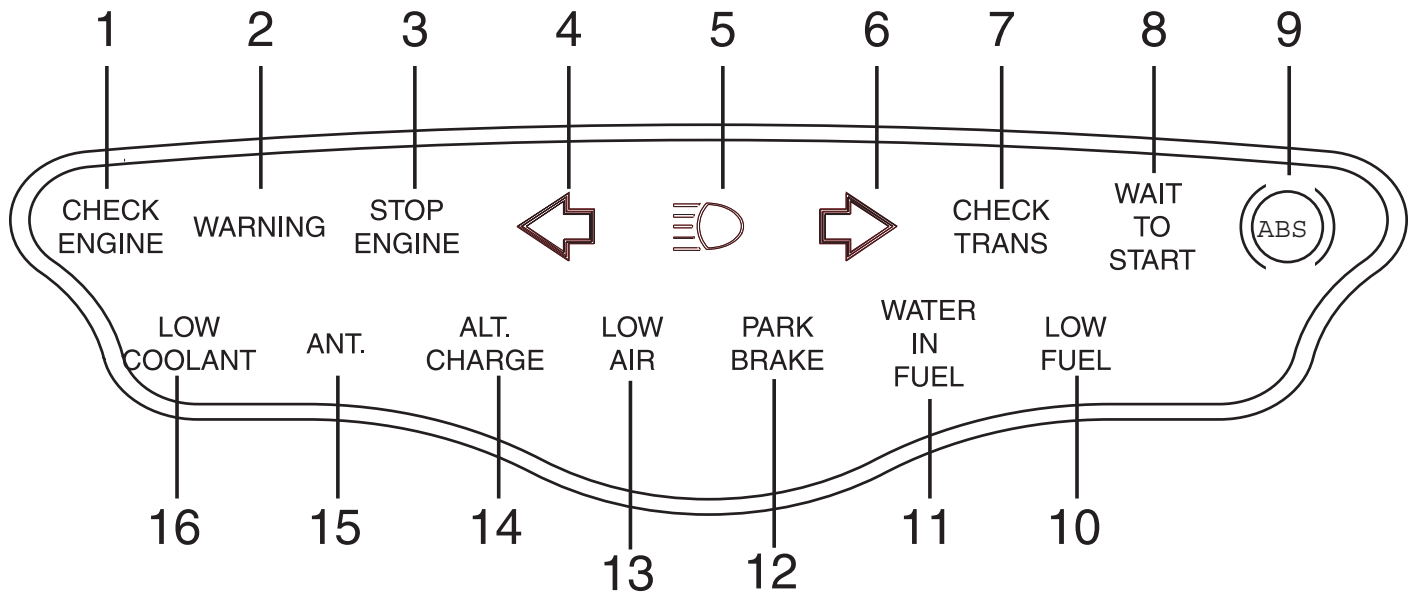

### 1. Check Engine:

This is a negative tripped light used only with the ISC Engine. Indicates water has been detected in fuel.

### 2. Warning

Indicates out of range condition exists within the engine protection circuits. Stop coach, check all fluid levels.

### 3. Stop Engine:

Alerts of severe out of range condition within the engine protection circuits. Pull over and stop as soon as possible. Shut-off engine to avoid engine damage.

### 4. Left Arrow - Audible Turn Indicators:

Indicates left turn indicator circuits active. Audible indicator cancels when the brake is applied.

### 5. Headlight Beam:

Indicates high beams when illuminated.

### 6. Right Arrow - Audible Turn Indicators:

Indicates right turn indicator circuits active. Audible indicator cancels when the brake is applied.

**7. Check Trans:**

Alerts of problems related to the Allison Transmission. The light should momentarily illuminate when the ignition is switched ON. When starting the lamp will extinguish indicating the circuits are working properly. If the lamp fails to illuminate or remains on, the transmission needs to be checked immediately. Contact the nearest Allison dealer.

**8. Wait to Start:**

This monitors the air intake heater at start. This is only used with the ISC engine.

**9. ABS:**

Indicates ABS possible fault in the ABS Brake system. Also indicates faults codes for service technicians.

**10. Low Fuel:**

Indicates fuel level is becoming low.

**11. Water in Fuel:**

This is a negative tripped light used only with the ISC Engine. Indicates water has been detected in fuel.

**12. Park Brake:**

Indicates parking/emergency brake is applied.

**13. Low Air:**

Indicates air tank pressures are out of operating range. Check air pressure.

**14. Alt Charge:**

Indicates a failure within the alternator charging system.

**15. ANT:**

Indicates TV antenna is raised. Lower antenna before moving coach.

**16. LOW COOLANT:**

Indicates coolant level in the overflow tank is below acceptable level.

## Gauges

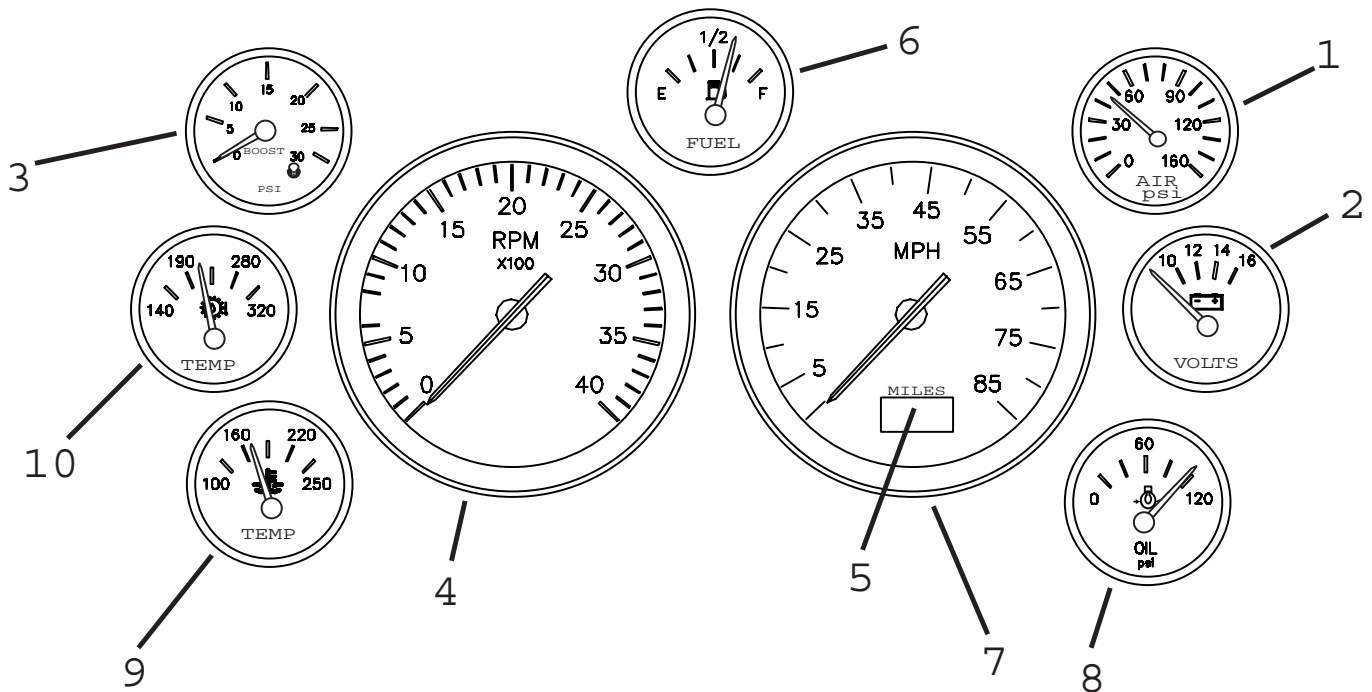

### 1. Air Pressure Gauge

This gauge indicates air system pressures. The normal air system operating pressures are 90 to 120 psi. These air pressures are preset at the factory. If a problem occurs with air system not maintaining normal operating pressure it is an indication of a malfunction in the air system. Use caution and stop the motorhome in a safe area. Contact your dealer immediately.



**NOTE: It is not safe to drive the motorhome with low air pressure. Damage can occur to the suspension and drive line. The operation of the air brake system is also affected.**

### 2. Voltmeter:

This gauge shows the charge condition in the chassis battery. The normal voltage with the ignition switch ON and the engine OFF varies between 12.0 and 13.0 Volts. With the engine operating without a heavy load the battery charging voltage is about 14.0 Volts. Battery readings of less than 10.5, or more than 15.0 Volts, usually indicates a battery or electrical system problem.



### 3. Turbo Boost:

Indicates boost pressure produced by engine turbocharger.

### 4. Tachometer:

Displays engine speed in revolutions per minute (RPM). Tachometer reads output pulse of alternator. If tachometer quits, or indicates irrationally, have alternator checked immediately.

### 5. Odometer/Trip Meter:

Odometer/trip meter records mileage driven as well as keeps track of mileage on a trip. To operate trip meter push button which changes odometer mileage reading to trip mileage reading. Reset button sets trip mileage back to zero.

### 6. Fuel:

Fuel gauge will register approximate fuel level in tank when ignition switch is in run position.



**NOTE: Fuel mileage varies with driving style and road conditions. Always average more than one tankful to obtain a more accurate figure. The diesel Generator uses fuel from main tank and will affect fuel mileage figures. Diesel Generators will not operate below 1/4 tank to insure there is enough fuel to run main engine.**

### 7. Speedometer:

Indicates the speed of the motorhome. The gauge indicates MPH and KPH.

### 8. Oil Pressure:

Indicates pressure of oil and not the amount of oil in system. Please refer to manufacturer's instructions for specific pressure recommendations.

### 9. Coolant Temp:

Under average conditions the gauge will read between 180° F and 205° F. Monitor this gauge frequently when CLIMBING HILLS, TOWING OR IN HIGH AMBIENT TEMPERATURES. If the gauge shows that an overheating condition exists (the needle moving above the 212° F area) IMMEDIATE ACTION should be taken.

#### **Overheating may be a result of any of the following conditions:**

- Low coolant level.
- Hydraulic fan motor failure.
- Mechanical failure of hoses or belts.
- Blocking of charge air cooler fins.
- Climbing a long hill on a hot day.
- Towing a heavy trailer.
- Idling for long periods of time.

### 10. Trans Temp:

Shows temperature of transmission fluid. Normal transmission operating temperature is 160-250° F. The maximum transmission to cooler oil temperature is 300° F. Do not let the transmission temperature exceed 275° F. If excessive temperature is indicated stop motorhome and shift to neutral. Accelerate engine to 1200-1500 RPM and allow temperature to return to normal.



**NOTE: Layouts will vary with difference in models or options.**

### Switches - Dash

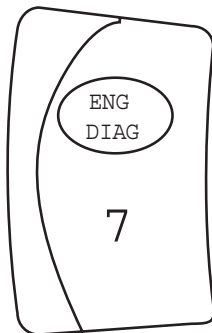
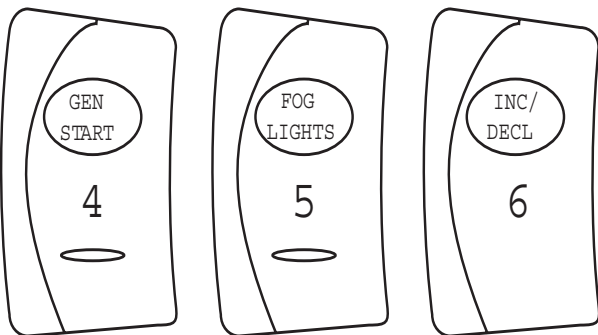
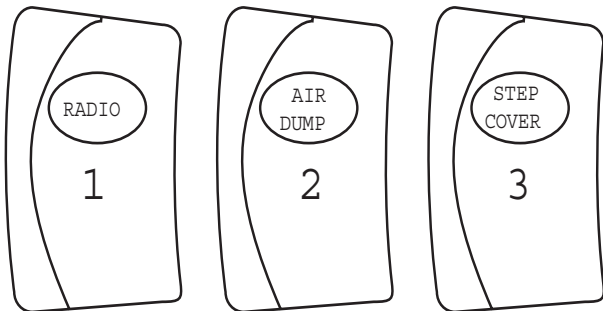

#### 1. Radio:

Turns radio on and off independent of main switch on radio.

#### 2. Air Dump:

Releases air from the chassis air bags to lower the coach.

#### 3. Step Cover:

Motorhome is equipped with a sliding Step Well Cover that is extended and retracted with this switch.

#### 4. Gen Start:

Starts and stops generator from the dash area.

#### 5. Fog Lights:

Turns fog lights ON and OFF for better visibility.

#### 6. Increase/Decrease

This switch will increase and decrease the engine idle in 25 rpm increments. There are limits to the idle speed, about 700 to 875 rpm.

#### 7. Engine Diagnosis

Checks engine functions.

**8. Wiper/Washer:**

Wiper operations are controlled when rotating knob to the right. When the knob is rotated from OFF to DELAY, the wiper will turn on and time delay between wipes (ranging from 45 seconds to 2 seconds) will occur. The amount of delay time changes as knob is rotated. A continuous low or high speed can be obtained by rotating the knob to the appropriate position. The wipers will be turned OFF with the switch in the OFF position.

When the end of the knob is pushed in washer fluid will be dispensed from the system and the wipers will turn on momentarily.

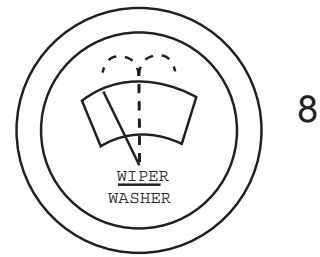

Wiper Control

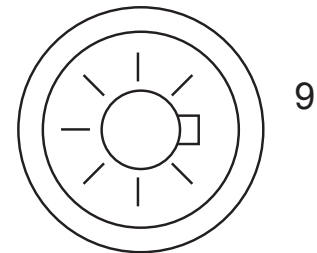

**9. Light Switch:**

Pull to first setting or parking lights. Pull all the way out for headlights. Turn right or left to adjust the brightness of the dash lights when lights are turned on. Turn all the way left for inside cockpit lights.

**10. Back Up Monitor:**

Used with the back up camera and will display the rear view of the motorhome.



**NOTE: Layouts will vary with difference in models and options.**

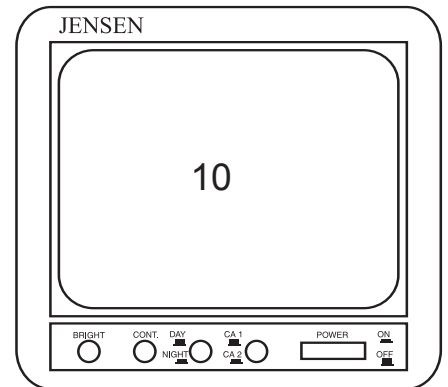

The system is designed to provide the driver with a view of the rear of the motorhome. The field of view is 140° in the diagonal plane, 121° in the horizontal plane and 90° in the vertical plane. Power will be supplied to the system when the ignition key is turned to the **Accessory** or **ON** position. The green LED will illuminate. The display on the monitor is controlled by the position of the power switch. When in the **ON** position, the display is present. When placed in the **S/B** (standby) position, the display is off until the gear shift lever is set to Reverse.

**Monitor Controls:**

- Power Switch - The switch is in the **ON** (in) position, turns on the monitor viewing. The green **LED** indicator will illuminate. When the switch is **OFF** (out), the monitor is in a standby mode of operation. The green **LED** will remain illuminated when the ignition is **ON**. The monitor will display rear viewing when the transmission is shifted to Reverse.

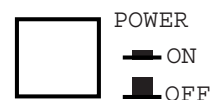

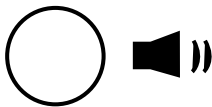
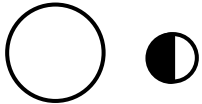
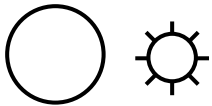
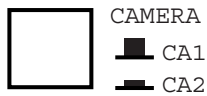

- **Camera Selector** - This switch should be left in the **CA1** (out) position. **CA2** (in) position is not used in the motorhome.
- **Day/Night** - This switch should be left in the **Day** (out) position for normal viewing. When set to the **NIGHT** (in), picture brightness is reduced. **NIGHT** should be used for night viewing and driving through tunnels.
- **Bright Control** - Clockwise rotation will increase the picture brightness. Counterclockwise rotation will decrease the picture brightness.
- **Contrast Control** - Clockwise rotation will increase the picture contrast. Counterclockwise rotation will decrease the picture contrast.

---

## **Air Conditioner & Heater Controls**

### **Air Conditioner Refrigeration Components:**

**Compressor** - The compressor is belt driven from the engine through the compressor and electronic clutch pulley. The compressor will pump freon from a low pressure gas into a high pressure, high temperature gas. This is the start of the refrigeration process.

**Condenser** - The condenser in front of the radiator is made of coils and fins which provide rapid transfer of heat from the refrigerant as external air passes over the coils. The high pressure gas is changed to a high pressure liquid.

**Condenser Fan** - A steady flow of cooling air is maintained across the condenser during system operations. The fan is part of the hydraulic system.

**Receiver-Drier** - Freon leaves the condenser, enters the dehydrator and is stored until needed. The drier filters out moisture in the system. It only takes one drop of moisture to cause a malfunction in the cooling unit.

**Expansion Valve** - The expansion valve suppresses the refrigerant into the evaporator according to the cooling requirements. The pressure is reduced in the restrictive effort of the expansion valve. A part of the valve is the capillary tube assembly. The capillary tube is the sensing bulb at the outlet of the evaporator.

**Evaporator** - A tube core and fins are used in the evaporator similar to the condenser. Air is blown through the fins to allow the evaporator to cool and reduce the pressure.

**Blower and Motor** - Just as the condenser has a fan, the evaporator has a fan called the blower. The blower will draw air from the cab area and force the air over the evaporator coils and fins. This forced air will ensure continuous vaporizing of the R134a.

**Relays and Switches** - Both electronic and vacuum switches are used in the control and operations of the system.

**Chemical Stability:**

The air conditioning system life and efficient operations depends upon the chemical stability of the refrigeration system. The refrigeration system is made of Refrigerant-R134a and Polyakylene Gycol (PAG) synthetic lubricant. It is very important that all materials contained within the refrigerant system be chemically compatible. The only suitable compound for use with R134a is PAG. The total amount of PAG withing the refrigerant system is approximately 18% of the total refrigerant in the system.

How much refrigerant is in the system or how much should be used when charging? You will need 1 oz. of PAG for each 7 feet of hose after the first 15 feet of hose. Roughly, a 40 foot motorhome will use 92 feet of refrigerant hose. Take 15 feet off the measurement and the result would be 77 feet. This 77 feet is then divided by 7 for total of 11. This represents the number of ounces of PAG oil needed for the A/C system, 11 oz.

Carrying the formula one step further, the 11 oz. equal approximately 18% of the entire system. The total will equate to approximately 61 oz. or 3.8 lbs. of R-134a.

TEMP F/ PSIG		TEMP F/ PSIG		TEMP F/ PSIG	
16	15.69	60	57.47	112	151.30
18	17.04	65	64.10	114	156.10
20	18.43	70	71.19	116	161.10
22	19.73	75	78.75	118	166.10
24	21.35	80	86.80	120	171.30
26	22.88	85	95.40	122	176.60
28	24.47	90	104.40	124	182.00
30	26.10	91	106.30	126	187.50
32	27.79	92	108.20	128	193.10
34	29.52	93	110.20	130	198.90
36	31.32	94	112.10	135	213.70
38	33.17	95	114.10	140	229.40
40	35.07	100	124.30	145	245.80
42	37.03	102	128.50	150	263.00
44	39.05	104	132.90	155	281.00
45	40.09	106	137.30	160	300.10
50	45.48	108	141.90	165	320.00
55	51.27	110	146.50	170	340.80

High pressure readings are another way to determine the amount of charge. The ambient temperature reading is measured one inch away from the condenser. The ambient temperature reading, plus 40°F, will equate to a value from the pressure table.

**EXAMPLE: 90° F**  
**1 inch from condenser**  
**+40°F**  
**130°F ----- 198.90**

**PSIG**-On fully charged system the expected pressure that should be seen on the HIGH-SIDE gauge will be around 200 PSIG.



**NOTE: All systems are charged at the factory with 4.0 lbs of R134A.**

**R-134a Refrigerant:**

R134a is classified non-explosive, non-flammable and non-corrosive. There is hardly any odor and it is much heavier than air. R134a is ozone friendly; however, it is not technician friendly. Proper care in handling and adequate ventilation must be observed. Under normal atmospheric pressures and temperatures R134a will evaporate so quickly it will freeze anything it comes in contact with. The open container boiling point for R134a is minus 21.7° F. This low boiling point makes for an ideal refrigerant. The tremendous amount heat transfer which occurs when a liquid boils, or vapors condense, forms the basic principles of all A/C systems. The amount of heat required to raise or lower the temperature of one pound of water by 1° F equals one British Thermal Unit (BTU). The BTU is the standard measurement of an air conditioner system.

**Safety and Handling 134A and Pag Oil:**

- When working with any refrigerant system wear eye protection and hand protection.
- Pag Oil irritates the skin. Flush with water immediately if in contact with any body part.
- Ensure any service work performed on the A/C system is in a well ventilated work area.
- Keep open flame away from service area. The discharge of a refrigerant gas near an open flame can produce a very poisonous gas.



**NOTE: O-rings used in a 134A system are Hydrogenated Nitrile Butadiene Rubber (HNBR). These are green in color and required for the 134A system.**

### **A/C Heater:**

The A/C system will also produce heat to warm the air in the dash area. Much like the refrigeration side of the system a liquid will be used in the process. This liquid is the engine coolant. The coolant is passed from the radiator to an electronic water valve. The water valve, when open, will allow the coolant to flow through the heater core. The heater core is tubing and fins. Air is drawn into the system by a blower motor through the outside recirculation door opening. Air is blown through the A/C evaporator core and then through the heater core. When the temperature control is in the WARM position coolant flows through the heater core. When the temperature is in the COOL position coolant flow by-passes the heater core. In either position the air flow is felt at the discharge vents.

### **Diagnosis of Electric Water Valve:**

Theory of Operation: Monaco Coach models with a center dial temperature control use a potentiometer at the control head for input of desired temperature. The water valve which controls the water flow to the heater core is opened and closed by a stepper motor mounted on the water valve. A control module compares the output voltage from the control to that of the feedback for the stepper motor of water valve. The control module then drives the motor to within one-half volt of the control potentiometer voltage.

### **Functional Test:**

- Start and operate the engine until the water reaches normal operating temperature.
- Set the HVAC temperature control to the full hot position.
- The discharge air outlets should have hot air.
- Rotate the temperature control to full cold position.
- Allow 10 minutes for the temperature to stabilize.
- The discharge air outlets should have cold air.

### **No Heat:**

- Check the blower and air mode operations. Fix or repair prior to proceeding.
- Verify the engine is reaching normal operating temperature. (Check with engine manufacturer for proper procedure.)
- Check the inlet hose at the water valve. The hose has hot water at the valve inlet. The inlet water temperature should be the same as the engine water temp.
- With the temp control on full hot position, check the outlet hose of the water valve. The hose should be at engine water temperature.



### Vacuum Generator:

The vacuum generator is important to the operation of the dash heating and A/C systems. This provides the vacuum to open and close the vacuum switches. When the vacuum generator is operating it creates 15 inches of vacuum and is passed to a reservoir ball. Most dash heater and A/C systems will only require 10 inches of vacuum to operate the switches. The output from the reservoir is sent to the vent control knob. The control knob will then direct the vacuum operation to the appropriate vacuum switch to open or close vents and switches. The vacuum generator uses the air from the front air storage tank through a 1/4 inch red air line. Whenever the ignition is ON and the A/C is operating the vacuum generator will operate.

### Dash AC and Heater Control:

The system is designed to only provide heating, cooling and defrost capabilities for the pilot/co-pilot area. The system is not capable of heating or cooling the entire motorhome.

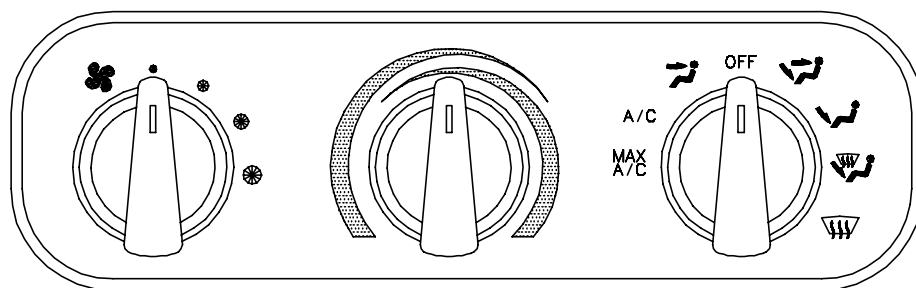

Blower Speed Control

Temperature Control

Mode Control Switch

### Blower Operation:

The blower is selected automatically when the desired feature is selected with the “select switch.” The system is shut off by placing the mode control switch in the “OFF” position.

### A/C Operation:

The A/C dash system will operate in all modes except VENT, FLOOR and OFF. The A/C and MAX positions engage the A/C compressor. When the switch is positioned in the A/C mode fresh air is drawn through the front air intake of the unit through the A/C coil. In the MAX position a damper door closes off the fresh air, while another door opens to permit only air from inside the coach to be used. When maximum cold air is desired this position should be selected. Also use this position when you do not wish to introduce outside air into the coach.



**Air Distribution Switch (Mode Control):**

This switch is used to direct air where it is needed to maximize the comfort of the motorhome.

**MAX A/C** - Recirculated air is drawn from the passenger area and discharged through the dash louvers.



**A/C** - Fresh Air is drawn from outside into the system and discharged through the dash louvers.



**VENT** - Fresh air is drawn in and discharged throughout the dash and defrost louvers.



**OFF** - The blower motor does not operate. The fresh air inlet door will close minimizing outside air infiltration into the the motorhome.



**BI-LEVEL** - Fresh air is drawn in and discharged through the dash, floor and defrost louvers.



**FLOOR** - Fresh air is drawn in and discharged through the floor louvers. A small amount of air is used to defrost the windshield.



**MIX** - Fresh air is drawn in and discharged through the floor and defrost louvers. The A/C system operates to dehumidify the discharged air.



**DEFROST** - Fresh air is drawn in and discharged through the defrost louvers. The A/C system operates to dehumidify the discharged air.

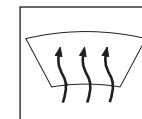

**Temperature Control Switch:**

This switch controls an electric water valve regulating the amount of engine coolant passing through the heating and cooling coils in the system. Rotating to the red area provides warmer air; rotating to the blue area provides cooler air.

**Blower Control Switch:**

The switch controls the speed of the blower motor, which is one of the best and most effective ways of controlling the temperature. The switch provides four speeds in all modes except OFF.

### **Operating tips and hints:**

Air intake and discharge temperatures are greatly effected by ambient temperatures and relative humidity. A large amount of cooling capacity is used to dehumidify air as well as cool it. After three to five minutes of A/C operations, the discharged air temperature should be approximately 30° F cooler than the fresh or recirculated air entering the AC system.

### **Winter Use:**

- De-ice the windshield using the DEFROST mode.
- Air will heat up faster with a slower blower speed until normal operating temperature ranges are reached.

### **Summer Use:**

- Close all windows and vents to hot, humid outside air.
- **MAX A/C** and **HI** blower will provide quick cool down.
- Use a lower blower speed to produce cooler air.

### **Troubleshooting:**

The dash A/C/Heat system uses a combination of compressed air (developed by the chassis system), vacuum air (developed by the vacuum generator) and electric relays and vacuum switches. Therefore, any repair can be classified in one of five categories.

- Electrical • Vacuum • Air Conditioner • Heater • Defroster

The motorhome compressed air tank must have adequate pressure to operate the vacuum generator or damper doors will not function. Also, the dash **A/C/Heat** unit must be switched **ON** to provide electric current to the relays, vacuum switches, etc. The dash A/C and heater system should be used monthly to keep the compressor lubricated.

The following information is provided to assist in troubleshooting common operational problems which may occur.

### **No Heating:**

1. A/C switch is turned off.
2. Blower switch is turned off.
3. Verify the proper engine coolant level.
4. Verify that the engine is reaching operating temperature.
5. Verify engine coolant is reaching water valve attached to unit.
6. Verify operation of water valve to permit engine coolant to pass through valve to heater core.
7. Check unit fuses.
8. Check power supply to water valve and grounding.
9. Check wiring.
10. Engine thermostat faulty.

**No Cooling:**

1. Check blower is operating, A/C switch is in A/C or Max position, temperature control is turned to max cooling (blue area).
2. System fuses are not blown.
3. Condenser fan is operating.
4. Check power supply to unit and grounding of system.
5. Check wiring.
6. Coolant valve leaking.
7. Drive belt loose or broken.
8. Compressor Clutch inoperative, will not engage.
9. Expansion Valve faulty or frozen.
10. Thermostat control faulty.
11. Mode control switch faulty.
12. Compressor faulty.
13. Loss of refrigerant.

**Reduced cooling:**

1. Coolant valve not operating correctly.
2. Air passages obstructed.
3. Loose or worn drive belt.
4. Check blower and select switch.
5. Thermostat control valve faulty.
6. Expansion valve faulty.
7. Compressor faulty.
8. Low refrigerant charge.

**Blower Does Not Operate or Runs Slow:**

1. Check fuses.
2. Check for loose or corroded connection.
3. Check wiring.
4. Check ignition switch is "ON".
5. Check blower and select switch.
6. Motor shaft seized.
7. Blower wheel out of alignment.

**Damper Doors Do Not Operate:**

1. Does motorhome air tank have pressure?
2. Check vacuum generator is being powered and producing vacuum.
3. Check vacuum line entering unit for vacuum.
4. Check that the vacuum solenoid mounted on unit are receiving power from the mode switch. If operating properly, the vacuum solenoid will feel hot if current is engaging the solenoid.
5. Check mode switch.
6. Check wiring.
7. Check for pinched vacuum line leading to the vacuum motor operating the damper door in question.

## DIAGNOSTIC PLUG LOCATION

Cummins and Allison diagnostic plugs are located in the roadside electrical bay just in front of the front wheel.

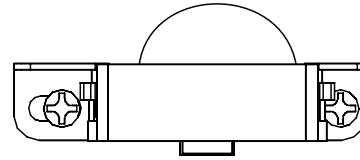

## SHIFTER PANEL Transmission Shifter

### Transmission Key Pad:

The function of each position of the keypad push-button shifter is as follows:

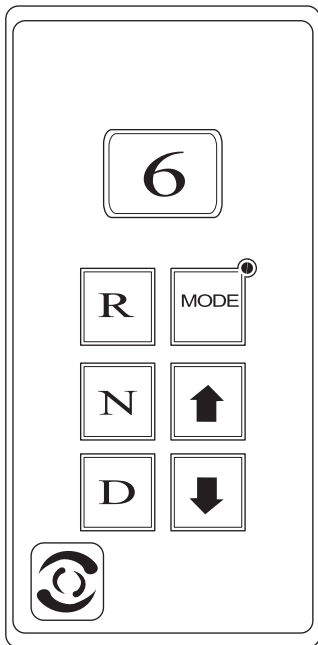

Transmission Key Pad.

- Select the REVERSE gear by pressing **R**.
- Select NEUTRAL by pressing **N**. The area around the **N** button is a raised ridge so the driver can orient his hand to the push buttons by touch, without looking at the display.
- Select DRIVE range by pressing **D**. The highest forward gear appears on the **SELECT** display and the transmission will shift to the starting gear.
- The UPSHIFT and DOWNSHIFT **arrow** buttons are used to select a higher (if not in **D**) or lower (if not in **1**) forward range. These buttons are not functional in NEUTRAL or REVERSE. One press changes the range selected by one range. If the button is held continuously the selected range will continue to change up or down until the button is released or until the highest/lowest possible range of gears is selected.
- The fluid level of the transmission can also be checked from the shift selector keypad. Press the up and down arrow button simultaneously while the motorhome is at a rest position. This activates the diagnostic circuitry of the transmission. To exit the diagnostics press **N**.



**NOTE: The oil level sensor method of checking the fluid level compensates for transmission fluid temperature between 60° C - 104° C (140° F - 220° F). Any temperature below 60° C (140° F), or above 104° C (220° F) will result in an Invalid for Display condition.**

The **MODE** button will enable the secondary shift point to be selected. The transmission shift point used will be 200 rpm lower. It is further used by a service technician to access diagnostic codes when troubleshooting. The diagnostic circuitry must be enabled to display the codes.

**To Enter Economy Mode:**

Press the **MODE** button. The LED will illuminate.

**To Exit Economy Mode:**

Press the **MODE** button. The LED will extinguish.



**CAUTION: Do not use the economy mode in heavy stop and go traffic or mountainous terrains. While in economy mode using heavy throttle applications with frequent shifting will raise transmission fluid temperature. Exit economy mode until road conditions improve.**

---

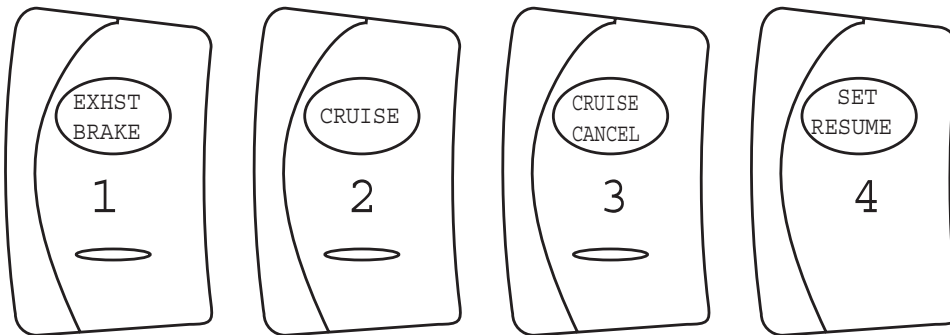
**Switches**
**1. Exhaust Brake:**

Exhaust brakes are auxiliary braking devices for slowing down your motorhome. For flat dry road conditions apply exhaust brakes until reduced speed is reached. Exhaust brakes are very effective for speed control in town and on local routes. Use your exhaust brakes to slow down when you are preparing to exit onto an off ramp, approaching traffic lights or approaching stopped or slow traffic. Using exhaust brakes at low RPM may cause engine stalling. Exhaust brakes are not a substitute for service brakes. Do not neglect service brake maintenance.

**2. Cruise:**

Turns cruise ON or OFF.

**3. Cruise Cancel:**

The operation of this switch signals the cruise system to disengage without losing the current speed memory setting.

#### 4. Set/Resume:

- Cruise SET - The operation of this switch actuates the Cruise Set function of the engine controller.
- Cruise RES - The operation of this switch actuates the Cruise Resume function of the engine controller.



**WARNING: To take control of your motorhome do not use cruise control in heavy traffic or on roads that are winding, slippery or unpaved. Do not shift the transmission into “N” (Neutral) with the cruise control on as high engine RPM run up will occur until the cruise control is turned off.**

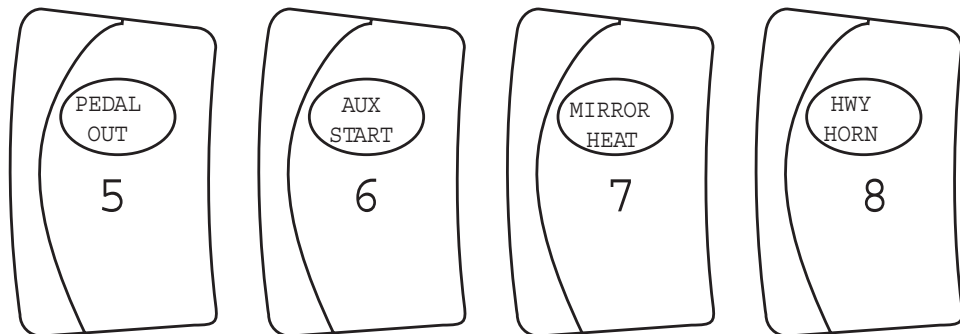

#### 5. Pedal In/Out

After sitting in the drivers seat and making adjustments to the mirrors and steering wheel use the Pedal In/Out switch to adjust the brake and throttle pedal to be either closer or farther away. The switch moves the pedals inward or outward approximately three inches. If you need to move the pedals inward just push the same switch in the opposite direction. When the pedal comes to the end of the traveling distance you will hear a different sound in the noise of the motor. Stop by releasing the switch. Do not continue moving the pedals. Damage to the motor and or fuses may result if operation of the switch continues after reaching the fullest extend or retract position.

#### 6. Aux Start:

Borrows power from the house batteries to help the chassis battery to start the engine.

#### 7. Mirror Heat:

This switch turns on the heaters in outside rear view mirrors. The mirror heaters should be used when defogging or deicing is needed. Mirror heat should not be left in the ON position unless continuous fogging conditions occur.

The outside mirrors have been placed so they can be easily adjusted with an Allen wrench. After taking delivery of the new motorhome it will be necessary to sit in the drivers seat and have the mirrors adjusted for accurate visibility. Make sure you can see out of both the driver and the passenger side mirrors, before heading out on the road.

Using your left hand you can make the adjustments to the mirrors with little effort. When using the mirror heat switch, just turn the switch to the on position. Only use the mirror heat long enough to defrost the mirror.

- Top Mirror = convex glass.
- Middle Mirror = flat glass.
- Bottom Mirror = convex glass.

**8. Highway Horn:**

Push switch to sound horn.

**9. Mirror Control:**

This switch adjusts the bottom mirror of the rear view mirror. The small selector in the middle of the switch must be placed in the desired side. The middle position is to prevent accidental bumping of switch and changing the mirror position.

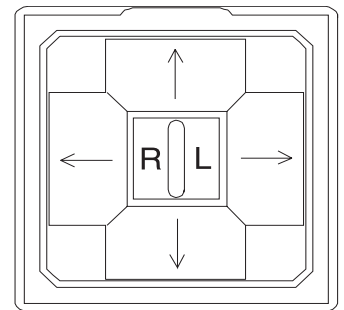

9

**10. RVA Control (Hydraulic Systems)**

The three point hydraulic leveling system is operated from the control module. You can manually or automatically level the motorhome. The control features a multiple warning system with flashing lights and a bong alarm to alert you of the jack down position.

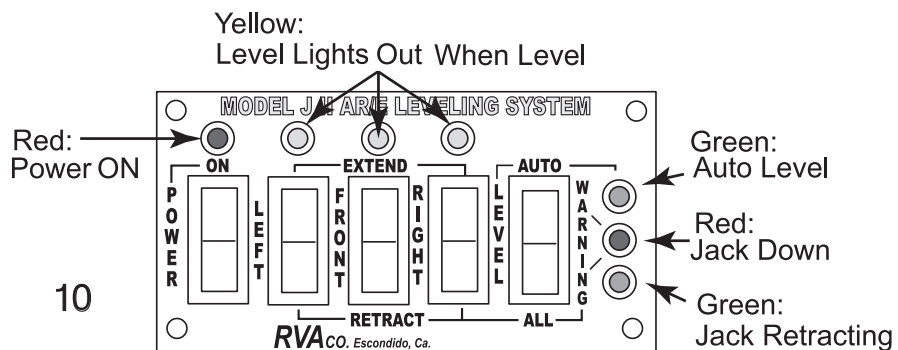

10

## Parking Brake



The park brake system is activated when the push-pull control knob is pulled. When the knob is pushed the brake is released. Prior to driving allow time for the air compressor to build up sufficient air to shut off the air warning lamp and buzzer.

## STEERING COLUMN

### Tilt & Telescope

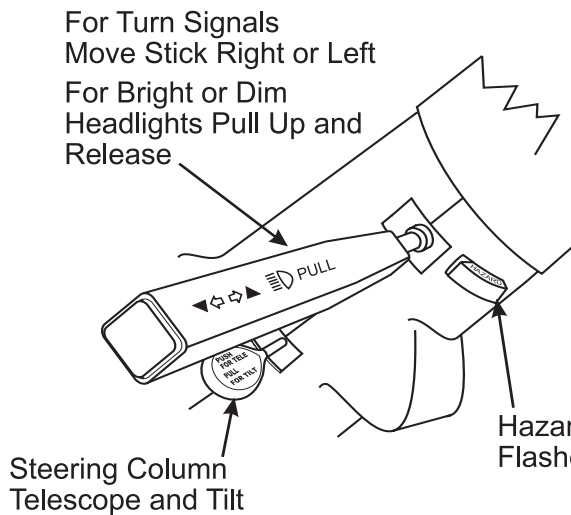

Tilt and telescope steering wheel control lever is located on the steering column.

- To tilt the steering wheel pull the lever up. Tilt the steering wheel where you want it. Release the lever and it will lock the steering wheel in the new position.
- To telescope the steering wheel push and hold the lever down. Push down or pull up on the steering wheel until the wheel is where you want it. Release the lever and the steering wheel will lock in the new position.

Turn indicator and headlight high/low dimmer control lever is located on the steering column.

- Pushing the lever forward will activate the right turn indicator circuits when the ignition is on.
- Pulling the lever down will activate the left turn indicator circuits when the ignition is on.
- Pulling the lever up will select high/low beam

circuits when the head lights are ON.

## Hazard Flasher

The flasher button is located on the steering column.

- To turn four way flasher on pull out on flasher button.
- To shut off flasher push button inward.



**FUSES & CIRCUITS  
- CHASSIS  
Distribution Panel -  
Front**

The front electrical panel is located on the roadside, ahead of the front wheel. It contains the fuses, self resetting supply circuit breakers, solenoid and relays.

The automotive fuses and emergency flashers are located in the front electrical panel. The fuses are the standard plug-in type (ATO). When a fuse “BLOWS” the wire in middle of the plastic case will be broken. A bad or blown fuse must be replaced with a fuse of the same rating and type. Using a fuse of a different type rating will defeat the circuit protection provided by the fuse, which could result in damage to the motorhome’s electrical system. If a fuse has been replaced and it “BLOWS” repeatedly, that may be an indication that a fault exists or an electronic component has failed. It is recommended that the motorhome be taken to a qualified RV technician before any future use to diagnose and repair the problem. Circuits are identified on the fuse label located on the inside of the electrical compartment door.

**Circuit Breakers And Fuses**

**House:**

1. Slide-Out Room - 15 amp Circuit Breaker
2. LP/CO Detector - 3 amp Fuse
3. Power Seat (Driver) 15 amp Circuit Breaker
4. Power Seat (Passenger) 15 amp Circuit Breaker
5. Storage Lights - 15 amp Fuse
6. Service Lights/LP SOL - 15 amp Fuse
7. Auxiliary Start/TV AMP 7.5 amp Fuse
8. Reserved
9. Map Lights 7.5 amp Fuse
10. C.B. Radio 2 amp Fuse
11. Service Light/Aux Power Jack 15 amp Fuse
12. Dash Fans 15 amp Fuse

**Chassis:**

13. Step Switch 7.5 amp Fuse
14. Step Motor 25 amp Fuse
15. Reserved
16. Roof Horns 15 amp Fuse
17. Sunvisors 5 amp Fuse
18. Step Slide 15 amp Fuse
19. Reserved

**Accessories:**

20. Rear Vision 5 amp Fuse
21. Leveling Jacks 15 amp Fuse
22. Air Dumps 15 amp Fuse
23. Auxiliary Lights 15 amp Fuse
24. Spot Light 15 amp Fuse

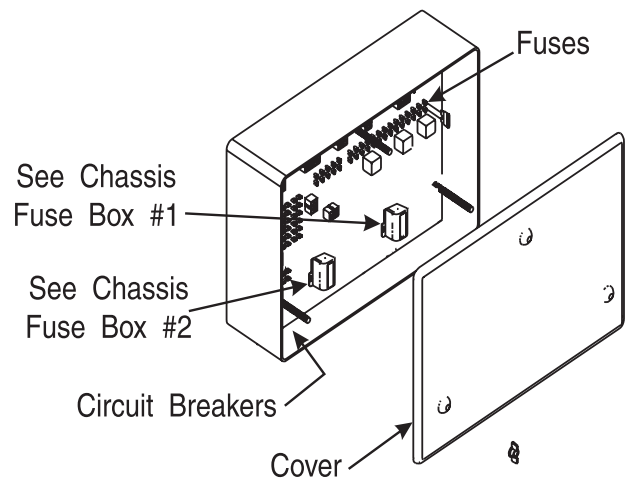

Front Distribution Panel

**Ignition**

- 25. Air Conditioner 20 amp Fuse
- 26. Jack/Antenna Warning Lights 5 amp Fuse
- 27. TV IGN Relay 7.5 amp Fuse
- 28. Slide-Out IGN Relay
- 29. Mirror Heater 15 amp Fuse
- 30. Mirror Control 1 amp Fuse
- 31. Reserved
- 32. Reserved
- 33. Step/ISO/Vac Sense 7.5 amp Fuse

**Marker (Chassis)**

- 34. Marker Lights 7.5 amp Fuse

**Circuit Breakers**

- Refrigerator 2-Way/3-Way 5/30A
- Interior Fuse Panel 50A

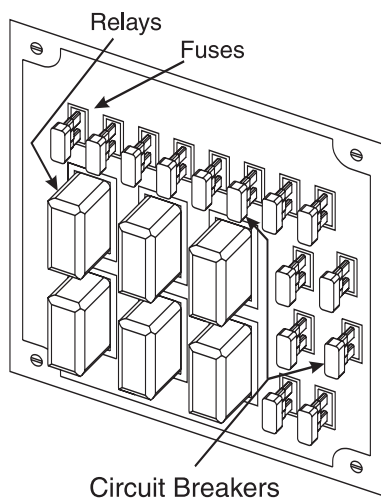

**Monaco Coach 1 Chassis Assignments:**

**FUSES, Left - Right - Down:**

- Marker Lights - 20A
- Right Rear Turn - 15A
- Left Rear Turn - 15A
- Horn - 20A
- Marker/Headlight Switch - 15A
- Key Switch Feed - 10A
- DRL - 25A
- Reserved
- ABS BAT - 20A
- Reserved
- ACC - 10A
- Panel - 10A

**CIRCUIT BREAKERS**

- Clutch Condenser - 20A
- Wiper - 10A

**RELAYS Left Top - Right Bottom:**

- Marker Lights
- Left Rear Turn
- ACC
- Right Rear Turn
- Horn
- Clutch/Condenser

**Monaco Coach 2 Chassis Assignments:**

**FUSES, left Top - Right bottom:**

- Park Bell - 10A
- Brake Lights - 20A
- Head Lights - 25A
- Hazard Flasher - 20A
- Park Bell - 10A
- Exhaust Brake - 20A
- Air Dryer - 15A
- Turn Flasher - 20A
- Back-Up Lights - 15A

- ABS IGN - 5A
- Dash IGN - 10A
- Eng/Tm IGN - 5A

**RELAYS Left Top - Right Bottom**

- Ignition
- Park Bell 1
- Park Bell 2
- Exhaust Brake 2
- Exhaust Brake 1
- Brake Lamps

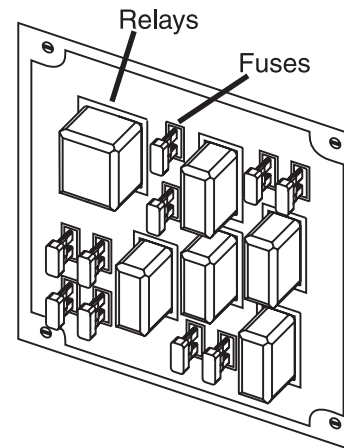

---

**ALTERNATOR**

The Leece-Neville alternator with integral rectifier and regulator and remote voltage sensor is designed for reliable high output at all RPMs. This alternator offers high output over a broad range of operating speeds. The 4884JB deliver the same reliable, heavy duty performance all Leece-Neville alternators are known for. The 4884JB features an integral regulator and rectifier for compact installations. While driving, if you notice that your tachometer is not operating, you may want to have your alternator checked. The tachometer is wired to the stator terminal of the alternator. Always keep a close eye on the voltmeter in the dash area.

The alternator should replace the amp-hours taken from the battery at start. The amount of charge given to a battery is dependent on engine run time. This allows to maintain a 75% level with enough energy to power the electrical systems. Driving the motorhome for a short distance or short periods of time, the battery may not get brought up to above 75% level.

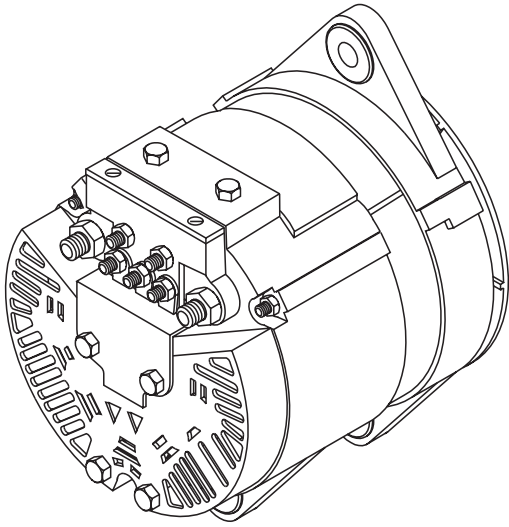

**Specifications:**

- The integral rectifier system utilizes 12: 50-amp diodes mounted in multiple aluminum heat sinks for efficient heat dissipation during high-output operation.
- Aluminum housings
- Bi-directional fan
- Front bearing: 305 cartridge type
- Enclosed brush system
- Operation Ambient Temperature Range (-40° to 200°F)
- Negative Ground Configuration
- Regulator Adjustment Range 13.6 to 15.4 Volts
- Batteries may start to gas at 14.3 Volts
- Max. Operating RPM 8,000

---

**Check Out Procedure**

- Check all wiring for burnt or loose electrical connections. Repair as needed.
- Check all grounds and electrical connections to ensure they are clean and tight.
  - a. Alternator ground to chassis frame.
  - b. Motor block ground to chassis frame.
  - c. Chassis battery ground to chassis frame.
  - d. Alternator positive output to isolator center terminal.
- Inspect the alternator for damage. A broken fan blade can damage an alternator or make it out of balance.
- Check belt, pulley and fan for wear. Replace as needed.
- Never attempt to disconnect the battery or battery wire from the alternator with the engine running. This can cause damage to the alternator or the regulator.
- The pulley for the alternator should be torqued to 80 foot pounds.
- Chassis battery voltage with the engine OFF should range from 12.2 to 12.7 VDC.
- Chassis battery voltage with the engine at idle should range 13.5 to 14.2 vdc.
- The output of the alternator range is 13.6 to 15.4 vdc. Connect a volt meter to the (B+) terminal of the alternator and chassis ground. Idle the engine up to 1200 rpm.
- Connect a clamp-on amp-meter, if available, to the positive battery cable to verify the battery state/rate of charge.

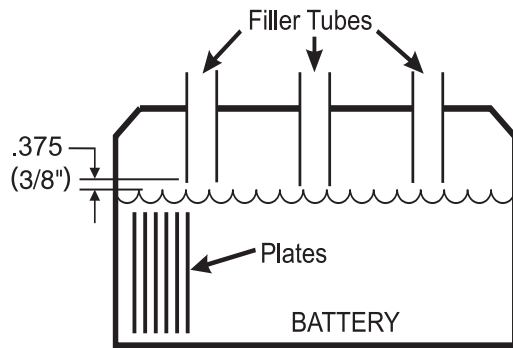

Battery State of Charge	Spec. Gravity	Voltage
100%	1.265	12.7
75%	1.225	12.4
50%	1.190	12.2
25%	1.155	12.0
Discharged	1.120	11.9 or Less

STATE OF CHARGE	VS	SPECIFIC GRAVITY
100%		1.265
75%		1.225
50%		1.190
25%		1.155
Discharged		1.120

NOTE: The distilled water level in battery should be 3/8" below the filler tube.

*The distilled water level in battery should be 3/8" below the vent tube.*

Remember the alternator is not a battery charger. It is designed to maintain the proper operating voltage level for the motorhome. A battery with a low charge or a dead battery may cause damage to the alternator.

The battery maintainer is a fully automatic device that keeps the chassis battery fully charged whenever your motorhome is plugged into shore power or your generator is running.

### Battery Maintainer

- For easy reference the battery maintainer has a green LED to indicate when it is active. It is illuminated whenever you are plugged into shore power, or when the genset is running. It is also illuminated when the engine is running, but that is of no consequence.



**NOTE: If the green LED is not illuminated when you are plugged into shore power run the engine for a few seconds to activate the battery maintainer.**

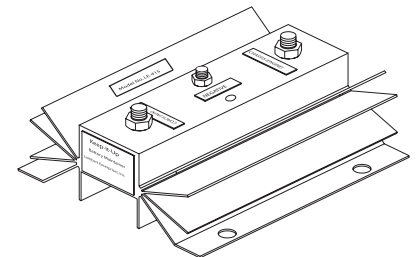

- The battery maintainer will provide up to 15 amps to the chassis battery.
- If the chassis battery voltage is low you may hear a clicking sound from the battery maintainer. This is normal and indicates that the chassis battery is trying to draw more than 15 amps. The sound will stop as soon as the battery has become recharged.
- While dry camping with the generator off, the battery maintainer becomes inactive and the green LED will go out.

**BULB USAGE -  
EXTERIOR**

<b>EXTERIOR BULB CHART</b>	
<b>LOCATION</b>	<b>BULB NUMBER</b>
<b>LOW BEAM</b>	<b>GE H7 58520U</b>
<b>HIGH BEAM</b>	<b>SYLVANIA 9005 HB3 U</b>
<b>TURN SIGNAL - FRONT</b>	<b>SYLVANIA 3457</b>
<b>TAIL/TURN - REAR</b>	<b>SYLVANIA 1157</b>
<b>LOWER &amp; UPPER MARKER LIGHTS</b>	<b>GE #59</b>

## ADDENDUM TO PAGE 9-223

The **Battery Maintainer** was never used on the Diplomat Motor Home and the following article was erroneously placed in this manual. Please disregard the information on the **Battery Maintainer**.

### **Battery Maintainer**

The battery maintainer is a fully automatic device that keeps the chassis battery fully charged whenever your motorhome is plugged into shore power or your generator is running.

- For easy reference the battery maintainer has a green LED to indicate when it is active. It is illuminated whenever you are plugged into shore power, or when the genset is running. It is also illuminated when the engine is running, but that is of no consequence.



**NOTE: If the green LED is not illuminated when you are plugged into shore power run the engine for a few seconds to activate the battery maintainer.**

- The battery maintainer will provide up to 15 amps to the chassis battery.
- If the chassis battery voltage is low you may hear a clicking sound from the battery maintainer. This is normal and indicates that the chassis battery is trying to draw more than 15 amps. The sound will stop as soon as the battery has become recharged.
- While dry camping with the generator off, the battery maintainer becomes inactive and the green LED will go out.

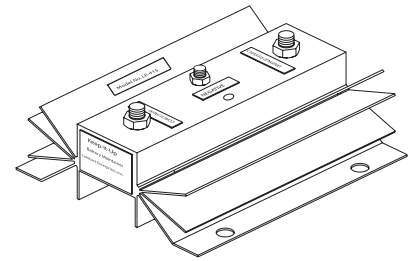

# Diplomat

INTRODUCTION • 227	SECTION 10
AIR SUPPLY SYSTEM • 228	CHASSIS INFORMATION
AIR GOVERNOR • 228	TRANSMISSION • 253
AIR DRYER • 229	<i>Transmission - Check Light</i> • 254
AIR STORAGE TANKS • 229	<i>Transmission - Periodic Inspections</i> • 255
AIR COUPLER - UNIVERSAL • 230	TRANSMISSION LUBRICATING FLUID • 257
AIR SYSTEM - CHARGING (EXTERNAL) • 230	<i>Cold Check</i> • 257
RIDE HEIGHT VALVES - <i>Adjusting</i> • 231	<i>Hot Check</i> • 258
<i>Checking Ride Height</i> • 231	FUEL TANK • 259
SUSPENSION AIR RIDE BAGS • 232	FUEL/WATER SEPARATOR (ISC Engine) • 259
<i>Checklist - Air bag Inspections</i> • 232	FUEL SENDING UNIT • 259
BRAKE SYSTEMS - AIR BRAKES • 233	HYDRAULIC SYSTEMS (ISC) • 260
BRAKE - PARK & EMERGENCY SYSTEMS • 234	<i>Hydraulic Pump</i> • 261
BRAKE ADJUSTMENT/SLACK ADJUSTER • 234	<i>Hydraulic Cooler</i> • 261
ABS SYSTEM (Anti-Lock Brakes) • 235	<i>Hydraulic Fan System</i> • 262
BRAKE SYSTEMS - BACK UP • 237	<i>Therموالve</i> • 262
ALIGNMENT SPECIFICATIONS • 238	<i>Switching Valve</i> • 262
SHOCK ABSORBERS • 240	<i>Fan Motor</i> • 263
LEVELING SYSTEM - Hydraulic Leveling... • 241	<i>Hydraulic Filter Reservoir</i> • 263
<i>Retracting Leveling Jacks</i> • 242	STEERING GEAR • 264
<i>Leveling Jacks Maintenance</i> • 243	AIR FILTER MINDER • 264
ENGINE - GENERAL INFORMATION • 245	AIR FILTER - CHANGING • 265
ISC ENGINE • 245	DRIVE AXLE LUBRICANT • 265
STARTING PROCEDURE (ISC NORMAL) • 246	DRIVELINE • 266
STARTING PROCEDURE - COLD WEATHER • 246	LUBRICATION CHART • 267
OIL RECOMMENDATIONS (ENGINE) • 246	PARTS - COMMON SOLENOIDS & SENDERS • 269
<i>Oil Recommendations - Cold Weather</i> • 248	CHART - TIRE • 271
ENGINE SHUTDOWN • 249	CHART - FILTERS & BELTS • 271
ENGINE SHUTDOWN - Extended • 249	CHART - SPECIFICATIONS • 272
COOLANT • 249	CHASSIS LOG • 273
<i>Coolant - Additive (SCA)</i> • 250	INDEX • 276
FUEL SYSTEM • 251	GLOSSARY OF TERMS • 279
BRAKING - ENGINE • 251	
BRAKE - EXHAUST (ISC Engine) • 252	
JUMP START • 252	





**INTRODUCTION**

This chapter contains knowledge and information on various components of your motorhome chassis. Following the guidelines and procedures will help you to understand and operate your motorhome. Complete instructions for various components can be located in the operators manual included in the Owners Information File box.



**WARNING: When frame or other welding is involved for motorhome repair or modification. The following precautions are required to protect electric components in the motorhome chassis.**

- 1. Disconnect the (+) positive and (-) negative battery connection and any electronic control ground wires connected to the frame or chassis.**
- 2. Cover electronic control components and wiring to protect from hot sparks.**
- 3. Disconnect the wiring harness connectors at the transmission electronic control unit. Open bed storage compartment, open engine access door. ECU is located above the transmission.**
- 4. Do not connect welding cables to electronic control components.**
- 5. The welding ground cable should be attached no more than 2 feet from the part to be welded.**

The Roadmaster chassis has been designed to provide exceptional balance, handling and braking characteristics. The Roadmaster rear engine chassis is an engine and frame unit featuring a semi-monocoque tubular all steel frame design, providing greater structural integrity and more uniform stress distribution. Incorporated in the Roadmaster chassis is the exclusive air glide suspension system using eight outboard mounted air bags and shock absorbers. The design and set up is intended to provide the smoothest ride, best handling and trouble free service, while delivering top notch drivability. The chassis will also incorporate a three point hydraulic leveling system or air leveling system. The Roadmaster chassis design offers unsurpassed ease of maintenance and service.

The towing system incorporated in the construction of the frame is rated at 10,000 lbs towing and 1,000 lbs tongue weight.

The Roadmaster's exclusive cushion air glide suspension consists of front and rear axles with leading and trailing arms in a parallel four link arrangement. A panhard bar is provided for each axle to control side motion. Each axle is mounted to a wide platform H-frame which carries the coach body on eight outboard mounted air bags (4 front and 4 rear). Each of the eight air

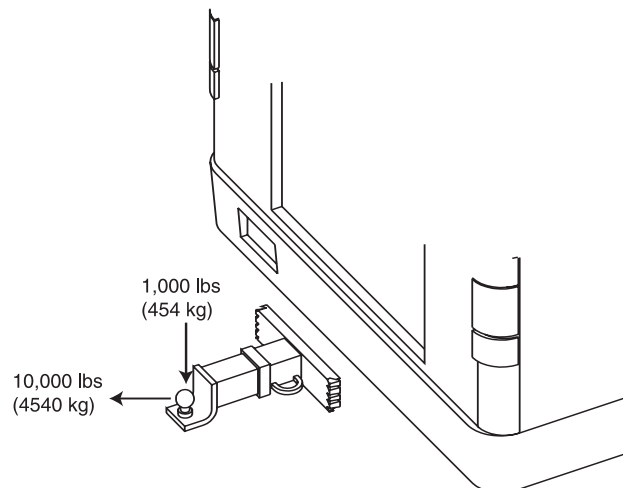

bags is coupled with a Bilstein gas shock absorber. The suspension control arms are attached to the frame through bushings, which require no lubrication.

The suspension ride height is preset and will maintain the proper ride height automatically, regardless of the load.

---

## AIR SUPPLY SYSTEM

The air compressing system on the motorhome is comprised of several items: an air compressor, air governor, air dryer, a front air tank and a rear air tank. The compressed air system operates several items, some of which include brakes, suspension, air horns, air gauge and stepwell cover. The air system is charged by a gear driven air compressor mounted on the engine. As engine speed increases, compressed air output increases. When the air is compressed, heat is generated. Heat dissipates as the air is discharged from the compressor. Moisture condenses in the compressed air as it cools. The moisture laden air then enters an air dryer where the air is filtered. The filtered air charges the front air tank. The front air tank is divided in two halves: a wet side and a dry side. The compressed air enters the wet side before entering the dry side. A discharge line from the dry side of the front air tank charges the rear air tank. The discharge lines use inline check valves to prevent back flow of compressed air.

The pneumatically operated items are divided into two categories: brakes and accessory air. Brakes have full use of supplied air pressure. Accessory air items such as air horns or stepwell covers receive air through pressure protection valves (PPV). The PPV will not allow compressed air flow until approximately 60 psi. In the event of an air system problem the pressure protection valve will leave a reserve air charge for braking. Pressure protection valves are installed for safety.

---

## AIR GOVERNOR

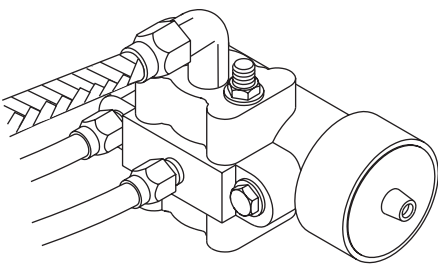

The air governor is located in the engine compartment. The air governor performs two functions: regulating the air compressor to cut-in and cut-out keeping the air system in the specified operating range of 105-120 psi; sending an air “purge” signal to the Air Dryer.

Cut-in pressure of approximately 105 psi is factory preset from the governor manufacturer and is not adjustable. Cut-out pressure is calibrated to 120 psi. When cut-out pressure is reached the governor will send an air purge signal to the Air Dryer. This opens the purge port of the Air Dryer, expelling moisture. The purge action of the Air Dryer is identified by the short release of air at the rear of the motorhome.

**AIR DRYER**

The air dryer is located in the roadside compartment behind the rear wheel. The air dryer removes moisture from the compressed air system. This is important because if air contains moisture it can freeze and prevent operation of brakes or other pneumatic operated items.

The air dryer has 3 functions: it cools, filters and dries air going through the motorhome's systems. If an excessive amount of water is present when performing the monthly air tank drain service it may be an indication the filters inside the air dryer need to be changed.

**The following conditions can also cause water accumulation and should be considered before replacing filter:**

- An outside air source has been used to charge system.
- In areas where a 30° range of temperature occurs in one day small amounts of water can accumulate due to condensation. Under these conditions moisture is normal and should not be considered a problem.

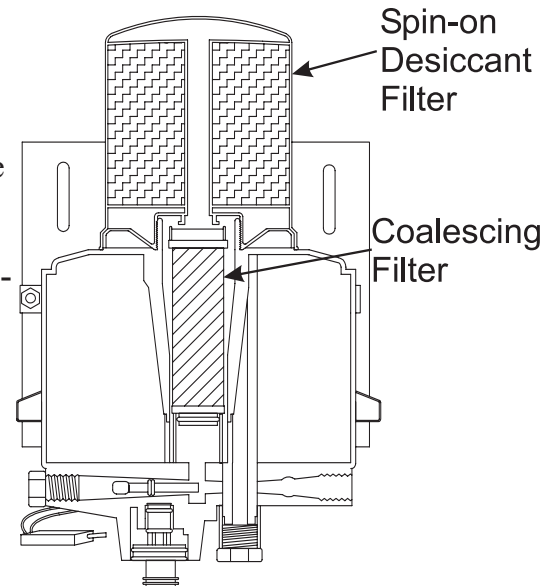

There are two filters in the air dryer that will need to be periodically checked and changed if necessary. First is the spin-on desiccant filter, second is the replaceable coalescing filter. Depending on how often the vehicle is driven, filters will need to be checked or replaced every 6 months to 1 year.

Remove coalescing filter to determine amount of contamination. If the filter looks black, filters need to be changed. If it is grey or white the filters are fine. Whenever you need to change filters make sure you change both filters, coalescing and desiccant, at same time. To remove filters unscrew desiccant filter and remove it. Next, reach in and remove coalescing filter.

The front and rear air tanks should be manually drained once a month, or more, depending on operating conditions where humidity is high. The front air tank has a drain valve for both the wet and dry side. The rear air tank only has one drain valve. Open the drain valves until all air is purged from tanks, allowing five extra minutes for moisture to be expelled. Remember to close the tank drain valves. Both air tanks have a pressure relief valve which is set to approximately 130 psi.

**AIR STORAGE TANKS**

## AIR COUPLER - UNIVERSAL

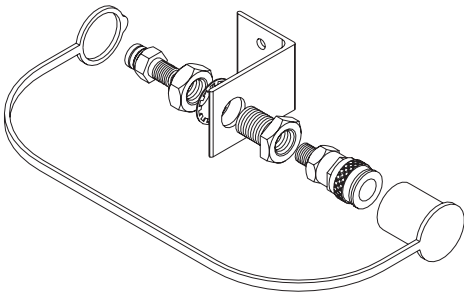

Provided for convenience is a remote air supply coupler. This is located in the roadside electrical compartment. This universal female fitting will accept several types of 1/4" ID male air fittings, including type C automotive. This auxiliary air fitting may be used to inflate tires, air mattresses or other pneumatic items.

### To use this feature:

- Remove the plastic protective dust cap.
- Using a firm grip, insert the air fitting into auxiliary air supply. The locking collar is spring loaded and will lock automatically when the fitting is properly inserted.

### To remove fitting:

- With firm grip hold air hose near fitting to prevent recoil.
- Slide the locking collar back to release fitting. The collar will lock into the open position when fully retracted.
- Replace protective dust cap when finished.

This fitting is not designed to charge the air system on the motorhome. The air supply for the auxiliary air fitting is charged from the front air tank through a pressure protection valve. Due to the small air pressure restriction of the pressure protection valve, maximum supply pressure is approximately 95 psi with air system on the motorhome charged to 120 psi.

## AIR SYSTEM-CHARGING (EXTERNAL)

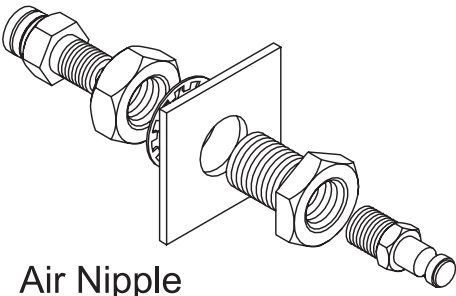

Air Nipple



**CAUTION: The external air supply source should be regulated to charge the air system on the motorhome no higher than 120 psi. Damage to the air system or pneumatically operated items may occur**

## RIDE HEIGHT VALVES

The ride height valves inflate or deflate the air bags keeping the motorhome at proper suspension height throughout the load range. There are three ride height control valves used on the motorhome. Two are used on the rear drive axle, these control rear suspension height and left or right tilt of the motorhome. Only one valve is used to control front axle suspension height. The ride height control valves are mounted to the main frame of the motorhome just above the axles. Each valve has a linkage rod connected the axle. The valves make small air adjustments to the air springs while traveling. Amount of system air used depends on the type of roadway surface and driving styles.

Should it become necessary to check suspension ride height start with air system fully charged and suspension at normal height. Motorhome must be on a flat level surface. Suspension height distance is measured from the top of the H-Frame to the bottom of the Main Frame Rail. Specified distances may vary plus or minus 1/4". Small adjustments to the rear valves may be necessary to compensate for slight tilt. Example: Adjusting curbside rear height control valve up will pivot roadside front corner down.



**NOTE: Driveline angle is affected by the suspension ride height. Improper driveline angle can damage suspension or shorten life of universal joints. Shock absorbers and air springs are in travel centers at proper ride height.**

### To adjust suspension ride height begin with:

- Motorhome on flat level surface.
- Air system fully charged.
- Suspension at normalized ride height.

Begin with front control valve. Loosen the adjusting locknut at the eccentric slot on the valve. Move the plastic arm up to raise suspension height, this will inflate air springs. Move the plastic arm down to lower suspension height, this will deflate air springs. Make small increment adjustments. When desired height is obtained insert a 1/8" or 7/64" inch twist drill bit into the plastic arm and valve body. This will central travel of internal piston. Tighten adjusting locknut between 60-80 in/lbs. Check adjustments made by using Air Dump switch to deflate air springs. Start engine to allow air system to become fully charged. Allow suspension to adjust and come to a neutral setting. Re-check suspension height measurement. Follow same procedure for rear control valves. Re-check the front suspension height when adjustments are made to rear height control valves.



**NOTE: Do not modify length of the linkage rods. Make necessary adjustments using eccentric slot on ride height control valve.**

### Checking Ride Height

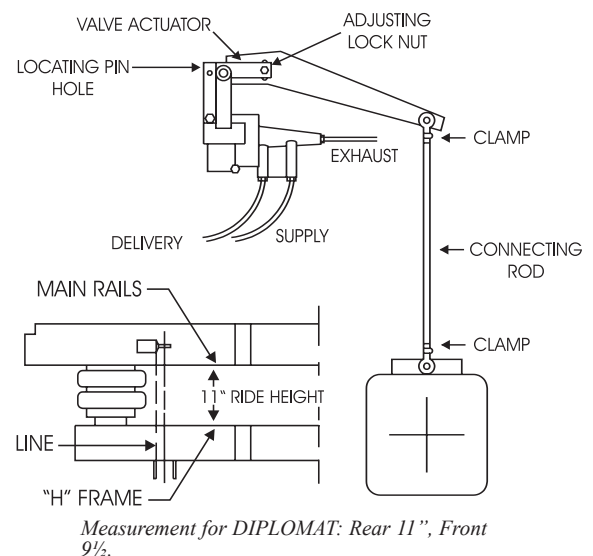

## SUSPENSION AIR RIDE BAGS

Air ride springs are available in single, double and triple convolution types plus reversible sleeve models for virtually every conceivable heavy-duty vehicle suspension application.

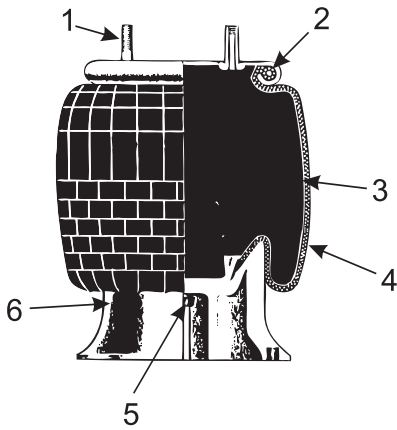

- 1. STUD.** Manufactured as a permanent part of bead plate assembly for maximum strength and durability. Used to attach spring to vehicle's suspension.
- 2. BEAD PLATE.** Crimped onto bellows at factory for a durable design and maximum quality control. Allows 100% leak proof testing prior to shipment.
- 3. BELLOWS.** "Air bag" includes four plies of material: inner layer, two plies of cord-reinforced fabric and an outer cover. Natural rubber construction provides functional properties to - 65° F.
- 4. BUMPERS.** A solid rubber or engineered plastic device designed to prevent significant damage to vehicle or suspension in event of a sudden loss of air pressure in spring.
- 5. PISTON.** Provides a lower mounting arrangement for air spring. Controls characteristics of spring under changing pressure loads.
- 6. PISTON BOLT.** Attaches piston to bellows. Sometimes extended as a means of attaching spring to vehicle suspension.

### Checklist - Air Bag Inspections

Listed below are items that can be checked when the motorhome is in for periodic maintenance.



**NOTE: Never attempt to service the air suspension on a motorhome with the air bags inflated.**

- Inspect the O.D. of the air springs. Check for signs of irregular wear or heat cracking.
- Inspect the air lines to make sure contact doesn't exist between the air line and the O.D. of the air springs. Air lines can rub a hole in an air spring very quickly.
- Check to see that there is sufficient clearance around the complete circumference of the air spring while at its maximum diameter.
- Inspect the O.D. of piston for buildup of foreign materials. (On a reversible sleeve style air spring the piston is the bottom component of the air spring.)
- The correct ride height should be maintained. All motorhomes with air springs have a specified ride height established by the manufacturer. This height should be



maintained within 1/4". This dimension can be checked with the vehicle loaded or empty.

- The leveling valves (or height control valves) play a large part in ensuring that the total air spring system works as required. Clean, inspect and replace if necessary.
- Make sure to check shock absorbers for leaking hydraulic oil and worn or broken end connectors. If a broken shock is found, replace it immediately. The shock absorber will normally limit the rebound of an air spring and keep it from overextending.
- Check the tightness of all mounting hardware (nuts and bolts). If loose, tighten. Do not over-tighten.

### **Cleaning**

The approved cleaning method is to use soap and water, methyl alcohol, ethyl alcohol and isopropyl alcohol. Unapproved cleaning methods include all organic solvents, open flames, abrasives and direct pressurized steam cleaning.

---

The motorhome is equipped with air brakes using much the same system as over the road trucks. This type of braking system is very efficient. Proper maintenance and lubrication is the key to keeping your brake system in proper working order. The brake system on the motorhome is designed to accommodate the weight of the vehicle and towing loads. This system differs from conventional automotive hydraulic braking system and should be treated differently.

## **BRAKE SYSTEMS - AIR BRAKES**

When operating a vehicle equipped with air brakes considerations need to be given to stopping distances and air system pressures. The heavier the vehicle the greater the kinetic energy. The motorhome requires longer stopping distances. Each brake application uses air from the air system. Give attention to the air gauge as well as the surroundings. Engine speed is directly proportional to how fast the air system is replenished. Prepare for downhill grades. Grades are generally posted in percentages. It may be necessary to select a lower gear. Make use of the engine or exhaust brake. When making brake applications use individual short applications down long hills rather than "riding" the brakes. This will extend the life of the brake linings. Avoid overheating the brakes. Hot brakes have less stopping power. When maneuvering the motorhome around in small areas or backing into spaces, several individual brake applications might be made. Watch the air gauge. Plan ahead when parking to make it easier on yourself. When preparing to back into a space, swing the motorhome so it is aligned with the parking slot before backing up.

The air braking system on the motorhome is equipped with several safety features unlike that of automotive hydraulic braking systems. One safety feature is a low air pressure warning system. Should a low air condition arise while the vehicle is under operation, a warning buzzer will sound and a dash warning light will illuminate alerting the operator of the situation. This warning occurs at approximately 60-



65 psi (pounds per square inch).

A simple mechanical explanation of what occurs when a brake application is made is as follows: The air system supplies air to the foot brake, this is called a treadle valve. Pushing down on the treadle valve supplies an air charge signal to a brake chamber. This sealed chamber consists of a spring and air bladder. The air charge signal pushes on the bladder which extends a threaded rod connected to the automatic slack adjuster. The slack adjuster rotates the S-cam expanding the shoes against the drum. Air disc brakes follow much the same principal, with the exception of the S-cams.

---

## **BRAKE PARK & EMERGENCY SYSTEMS**

The park and emergency brake systems are combined and apply to the rear drive axle only. These are called spring brakes. When the park brake is applied air is released from the rear brake chambers allowing the large spring in each rear brake chamber to manually push against the automatic slack adjuster. This rotates the S-cam applying the brake shoes against the drum. The air system charged above 35 psi is approximately the point at which the park brake will remain released. Pushing down on the park brake handle charges the rear brake chambers with air pressure, overriding the emergency brake springs and releasing the brakes. In the event of air loss while the vehicle is under operation, the park brake will automatically apply, (this occurs at approximately 30 psi) acting as an automatic emergency brake system.

When preparing to depart, allow the air system to achieve full air pressure. This is indicated by the air gauge needles. Listen for the air dryer to purge, indicating full air pressure has been obtained and air dryer is functioning. Look and listen for any abnormalities. Abnormal air pressure readings by either needle of the air gauge should alert the operator. Have the air system checked to avoid an untimely failure.

Should a failure occur in the air system that prevents the air pressure from building, it may become necessary to “cage” the spring brakes. This is an emergency procedure only. Caging the rear air brake chambers manually overrides the spring brakes and allows the vehicle to move. This procedure does not affect normal service braking. The brake disabling procedure is located in Section 2.



**NOTE When park brake is released park illumination lamp will remain lit until air system pressure is above 65 psi.**

---

## **BRAKE ADJUSTMENT/ SLACK ADJUSTER**

The motorhome is equipped with automatic slack adjusters. As brake linings wear the slack adjusters will automatically ratchet on the return stroke as needed. This ratchet action will keep the brake linings at proper adjustment. Brake adjustment should not be necessary. Indications of a vehicle needing a possible brake adjustment may be noticed by the park brake not holding on a hill or gradual loss of braking power.

Automatic slack adjusters and the connecting S-camshaft require periodic lubrication.



**NOTE:** Replacement parts should be of the same original equipment size and type. Mixing brake components may result in unequal braking action. Brake adjustments are part of normal maintenance of the motorhome. Brake adjustments are not covered by Monaco Coach.



**WARNING:** Brake lining may contain asbestos material and should only be serviced by qualified service technicians who are trained in the appropriate precautionary procedures. If any loss of braking effectiveness or abnormal braking indications are noticed, the brakes and slack adjusters should be inspected by a qualified brake technician.

The motorhome is equipped with an anti-lock braking system (ABS). The ABS system monitors wheel rotation speeds by using a 100 tooth magnetic tone ring mounted to the hub. Revolving with the wheel, the magnetic tone ring is polarized giving positive and negative pulsations. A stationary sensor is mounted adjacent to the tone ring monitoring the magnetic pulses. The pulses are monitored by the ABS electronic control unit (ECU).

The ECU monitors all available wheel sensors at the rate of 100 times per second. The ECU controls Pressure Modulator Valves. Pressure Modulator Valves have two electric over air solenoids, a hold solenoid and a release solenoid. The modulator valves are open under normal braking, allowing a straight through air signal from the treadle valve to the brake chamber. Should a wheel lose traction under a braking application, the ECU will energize the hold solenoid of the Pressure Modulator Valve to interrupt the air signal from the treadle valve to the brake chamber, while the release solenoid vents the existing air signal to the atmosphere allowing the skidding tire to regain traction. Skidding tires have less tractive efficiency. It is possible, under certain conditions, to have the wheel(s) skid with a normal functioning ABS system.

The ABS itself does not apply additional braking power. The purpose of the ABS is limiting brake torque to prevent wheel locking that results in the loss of lateral stability and increased stopping distances. Cautious driving practices and maintaining adequate safe distances when following vehicles is the key to safe vehicle operation.

## **ABS SYSTEM - (Anti-Lock Brakes)**

### **ABS Component Function:**

- Speed sensors and tone rings on each wheel monitor wheel rotation.
- Each speed sensor communicates wheel rotation pulses to the Electronic Control Unit.
- ECU receives the speed sensor inputs, interprets the signal pulses, calculates speed and acceleration rates of each wheel.

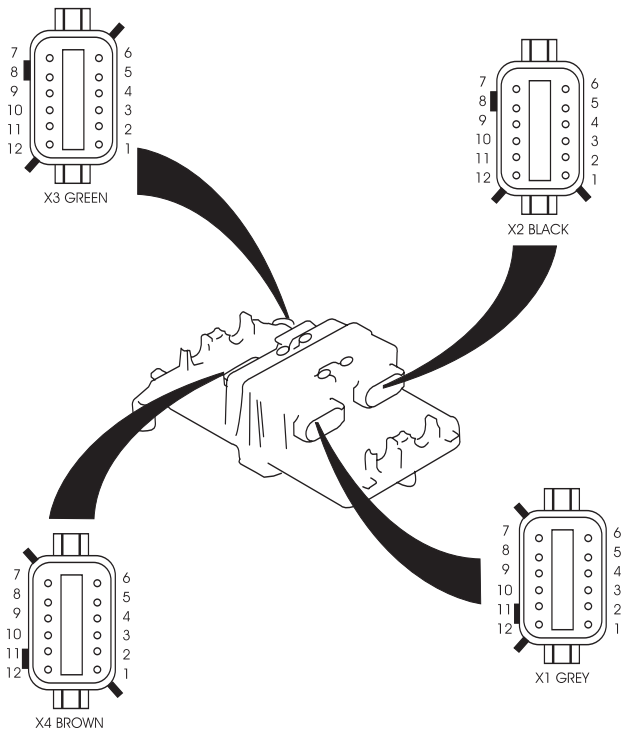

- Based on the speed sensor input, the ECU detects impending wheel lock and operates the ABS Modulator Valves required for proper control. The Modulator Valves can be operated in the air. Release or hold modes to regulate air pressure to the brake chambers.
- The braking force is applied at a level which minimizes the stopping distances while maintaining as much lateral stability as possible.

#### **ABS Warning Light:**

The ABS will perform a diagnostic indicator lamp check and self diagnostic test each time the ignition is switched to the on position. The ABS dash indicator light will illuminate momentarily (2.2 seconds) verifying the self check test. If the ABS indicator light remains on, or illuminates while the motorhome is being operated, there is a fault in the antilock brake system only. This fault will not affect normal service braking. The motorhome will need to go to a service center to repair the problem.

#### **ABS Blink Code:**

The ABS dash indicator light can be used to obtain system faults by displaying a blink code.

#### **To retrieve blink code(s)**

- Turn ignition key to the ON position.
- Using Systems Diagnostic Center located left of steering column below dash board, depress and hold test button for three seconds. Indicator light will illuminate while test button is depressed.
- After releasing test button, indicator lamp will turn off and blink code will be displayed: 1-1 will indicate no system faults.

The motorhome air braking system is equipped with several back-up safety systems and warning alarms in the event of an air system failure. Refinements to air braking systems have been instituted with safety as top priority. For example: should the air compressor fail to charge the air system and the low air gauge readings go undetected, a low air pressure warning buzzer will sound and low air pressure dash warning indicator lamp will illuminate. These warning indicators occur at approximately 65 psi. This will alert the operator of an impending situation. If the motorhome is allowed continued operation the pneumatic emergency spring brake relay valve installed in the air system senses the low air pressure condition. The emergency spring brake relay valve will release the air charge from the spring brake air chambers on the rear drive axle. In this case the park brakes will automatically apply at approximately 30 psi. This safety back-up system acts as an automatic emergency brake system.

Another back up safety is the air system separation of the front and rear brakes, implemented by using two air tanks. One tank is located in the front and the other is located in the rear. This separation allows the front air tank to operate the front brake. The rear tank operates the rear drive axle brakes and tag axle brakes if equipped with a tag axle. This tank division gives reassurance in the event of one tank having a failure of an accessory air item allowing the compressed air to escape. Accessory air items are other pneumatically operated items such as the air horn, step well cover, vacuum, generator, etc. The accessory air items operate only when air tank pressures exceed 65 psi. This is done with pressure protection valves. Should an accessory air item fail, the pressure protection valve (PPV) will reserve remaining air pressure of 65 psi for braking. This will leave the motorhome with one air tank fully charged for a safety back up.

Another situation, in which all compressed air has escaped from the rear air tank, a pneumatic back-up safety valve is installed. This is the safety inversion valve. The inversion valve senses the absence of rear air tank pressure. In this case the inversion valve will allow the operator to make a modulated spring brake application, made in conjunction with the emergency spring brake relay valve. The inversion valve allows the front air tank pressure to recharge the rear brake chambers after the modulated spring brake application has been made. This back-up system allows use of all the brakes, allowing the operator to bring the vehicle to a safe stop. In the event of all compressed air charge escaping from the front air tank the operator will still have full use of the rear brakes.

## ALIGNMENT SPECIFICATIONS

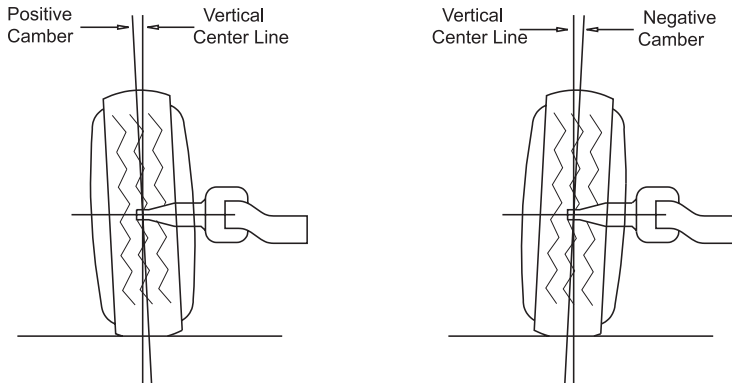

The correct wheel alignment promotes longer tire wear and ease of handling while minimizing the strain on the steering system and the axle components.

### Camber:

Camber, as shown below, is vertical tilt of wheel as viewed from the front of the vehicle. This is machined into the axle when manufactured and is not adjustable.

- “Positive” camber is an outward tilt of the wheel at the top.
- “Negative” camber is an inward tilt of the wheel at the top.

FRONT OF MOTORHOME  
(Top View of Axle)

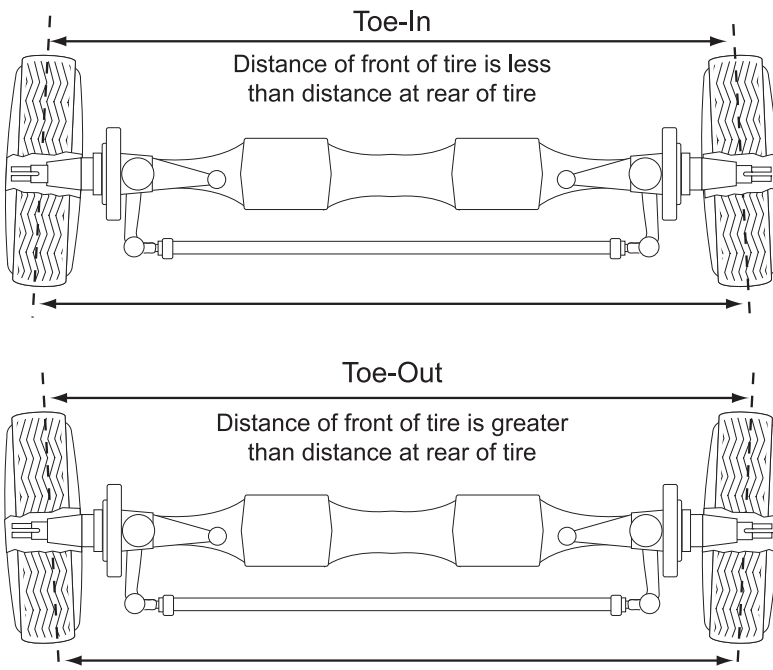

### Toe Setting:

The toe setting represents different distances between the front and rear of the tires (measured at the vertical centerline of the tires).

Toe-in occurs when the tire front distance is less than the tire rear distance.

Toe-out occurs when the tire front distance is greater than the tire rear distance.

Wheels are generally set with initial toe-in. As the vehicle operates, tires tend toward a toe-out condition. By starting with an initial toe-in setting a desirable “near zero toe-in” can be achieved when the vehicle is in motion.

Incorrect toe settings, where toed-in or toed-out, can have a significant effect on tire wear. The toe setting is adjusted by lengthening or shortening the cross tube.

The toe setting is .03 degree.

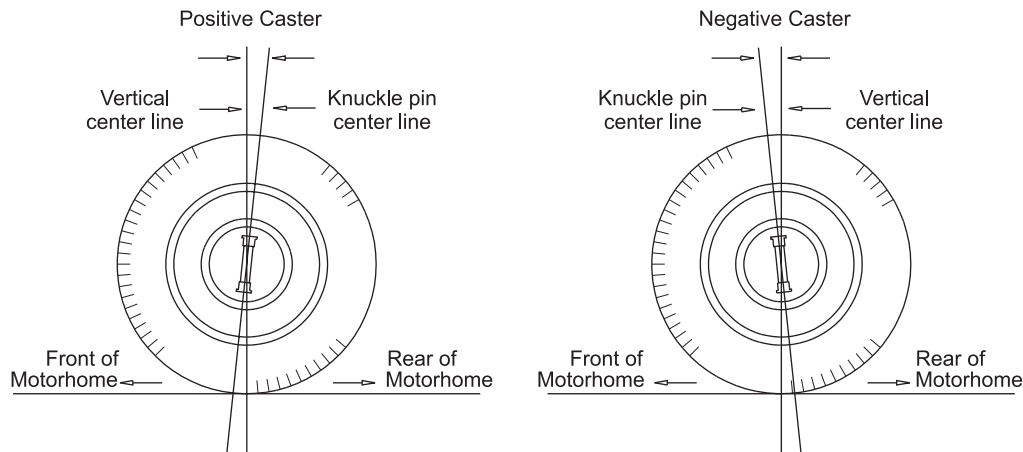

**Caster Adjustments:**

Caster is the fore and aft tilt (toward the front or rear of the motorhome) of the steering kingpin as viewed from the side of the motorhome.

“Positive” caster is the tilt of the top end of the kingpin toward the rear of the motorhome.

“Negative” caster is the tilt of the top end of the kingpin toward the front of the motorhome.

A caster angle more positive than specified may result in excessive steering effort and/or shimmy. An angle less positive may result in vehicle wander or poor steering return to center. The caster angle is determined by the installed position of the steer axle.

Left Front

	Min.	Nominal	Max.
Camber	-0.15°	-0.35°	-0.65°
Caster	3.50°	4.50°	5.50°
Toe	0.018°	0.03°	0.042°

Right Front

	Min.	Nominal	Max.
Camber	-0.15°	-0.35°	-0.65°
Caster	3.50°	4.50°	5.50°
Toe	0.018°	0.03°	0.042°

## SHOCK ABSORBERS

The shock absorber by definition is a hydraulic device used to dampen suspension/body movement. The road surface irregularities or roughness is compensated for by the shock absorber. The roadmaster chassis incorporates the "Bilstein" shock in the design of the exclusive air glide suspension system. This shock absorber is a telescopic, monotubed unit filled with nitrogen gas and hydraulic oil. The result of the mixture is uninterrupted damping for the smallest of wheel deflections.

By design, a self lubricating seal is used which will allow approximately 10% of the total oil capacity to pass onto the piston rod. The gradual process of oil loss does not affect the performance of the shock absorber during the service life. This process will be evident after a long period of service by an oil film on the body of the shock absorber. The appearance of a coating or film on the body or rod is completely normal, it is an indication the shock is functioning normally.

The road holding, handling, balance and braking characteristics all can be contributed to the shock absorber. The operating conditions for which the shock absorber must endure will determine the life span. However, since the only moving part is the piston rod there are no spring or hinge pins to wear out, get weak or deteriorate.



*Normal shock absorber  
appearance after long service period.*



## LEVELING SYSTEM

### Hydraulic Leveling System

The three point leveling system features a multiple warning system with flashing light and a bong alarm to alert you of the jack position. The system also features a remote control panel located next to the driver seat. The torsion stress is significantly reduced during proper operating procedures. Damage resulting from improper procedures can range from windshield damage to entry doors jamming.

The model 35 J-II leveling system pump is located curbside front with easy access from the generator door. The valve assembly manifold is mounted on the pump motor, providing easy access to the manual retract valves. The system is designed to be self bleeding in the event any component of the hydraulics has been removed or repaired. Fully extend and retract each jack twice. The remote rocker switches will operate with a minimum of 7.5 vdc. Optimum requirements for operating the system are voltages above 9.6 vdc.



**NOTE: The leveling system jacks are not designed for use in changing tires. This can cause problems with the suspension system, frame alignment and damage to the windshields.**

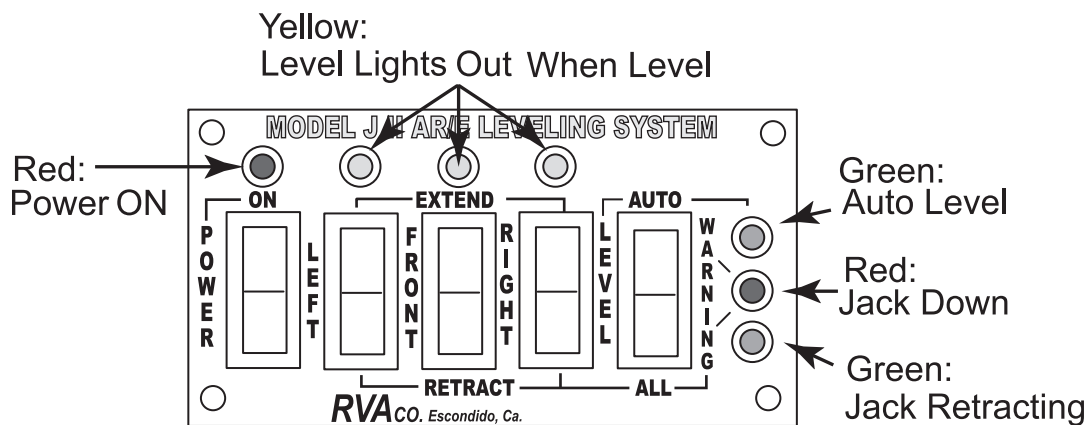

When manually operating the leveling system, always lower the front jack first. The front jack acts as a pivot point for chassis and reduces torsion stress on the body of the motorhome.



**NOTE: In the event the front of the motorhome is high and does not require elevating, it will be necessary to raise front of motorhome a minimum of 1/2 inch to allow jacks to act as a pivot point.**

The leveling system was designed to reduce site selection problems. If possible, park the motorhome with the front facing downhill. If the ground is soft, place a wooden 2 x 8 board under the foot of each jack pad to prevent sinking.

The front jack will be the pivot point for the chassis and is always low-



ered first. This reduces the torsion stress on the body of the motorhome. The bong alarm will activate when any jack is extended more than 2" to 6" from fully retracted position and will indicate low fluid level for the pump motor. The bond alarm may momentarily activate when driving over rough roads, or negotiating curves and corners. Usually this indicates low fluid level.



**NOTE: Air will automatically dump from air bags when leveling cycle begins. This will lower the motorhome and require less extension by the jacks. To expedite the air dumping, the motorhome is equipped with a manual air bag release switch located on the dash panel.**

- Place the gear selector in neutral.
- Apply the parking brake.
- Turn the ignition switch to the ON position.
- Engage switch labeled POWER on jack control console.
- Each yellow light and switch combination corresponds to each jack as positioned on the chassis and is labeled as such.
- To extend a particular jack, push rocker switch to the retract position and hold until the desired retraction is reached.
- When the yellow light goes off, that particular jack is in the level position.
- Turn off the switch labeled POWER on the jack control panel.
- Turn off the ignition switch.

---

## **Retract The Leveling Jacks**

The ALL JACKS RETRACT mode or MANUAL mode can be engaged at any time during automatic leveling operation.

Prior to automatic leveling it is essential that there is no movement in the motorhome. To extend the jacks automatically proceed as follows:

- Place gear selector in NEUTRAL.
- Apply the parking brake.
- Turn ignition switch to the ON position.
- Switch the main jack control power switch ON.
- Press the AUTOMATIC LEVELING/ALL JACKS switch.

If the yellow light illuminate, press down the rocker switch labeled AUTO-MATIC LEVELING and release. The top green light will start blinking. After a 1/2 second delay, pump motor will come on and all jacks will extend downward. The system will attempt complete leveling in one operation. The motorhome is level when all yellow lights, as well as green lights, go out.

If leveling is unsuccessful on the first phase, the system will attempt to level four subsequent times at seven second intervals.

If both green lights start flashing alternately, the motorhome has reached maximum extension on one or more jacks. One or more yellow lights will blink, indicating that additional height is required under one of the jack pads. This can be attained by moving motorhome to another location or getting additional height by placing a 2x8 block under one of the jack pads.

If you block under a jack pad, **ONLY ONE JACK SHOULD BE BLOCKED AT A TIME**. If blocking a rear jack pad while motorhome is on a slope, opposite set of rear wheels must be chocked to prevent rolling.



**WARNING: One jacks are extended down a red JACKS DOWN warning light will blink and an alarm will sound. An alarm will sound again if jacks are down and ignition switch is turned ON.**

Once motorhome is level turn off POWER switch on control console and turn off ignition switch. **BEFORE DRIVING OFF, ALWAYS PERFORM VISUAL INSPECTION TO INSURE THAT JACKS ARE UP.**

#### **Automatic Retract:**

Prior to retracting levelers it is advisable to start engine and build air pressure.

- Gear selector should be in NEUTRAL.
- Parking brake applied.
- Turn ignition switch to ON position.
- Engage power switch to ON position on jack control console.
- Press down rocker switch labeled ALL JACKS RETRACT and release.



**CAUTION: Do not move motorhome while jacks are still in contact with ground or extended, damage to jacks can occur. Do not raise any wheels off the ground, which could result in damage to the motorhome.**

Bottom green light will begin blinking and all jacks will retract. This operations is on a four minute timer which green light will stop blinking and go out.

Hydraulic pressure, in all jacks, is automatically released when ALL JACKS switch is engaged. Jacks are retracted by the weight of motorhome and retract springs on each jack.

#### **Manual Retract Valves:**

In the event of mechanical or electrical failure that would prevent the leveling jacks from being automatically retracted, the motorhome is equipped with manual emergency retract valves. These valves are located in the outside roadside rear compartment.

This manual system will release fluid under pressure in each jack and allow fluid to return to the reservoir. The jacks will then retract.

To operate the manual system turn all three valves counterclockwise until they stop.

Once the jacks are fully retracted, rotate all the valves fully clockwise. In the event one of the jacks is not holding pressure, check the position of the retract valve.



**NOTE: Do not move the motorhome until the jacks are fully retracted.**



**CAUTION: The motorhome will raise or lower as the bypass valves are opened. Do not crawl under the motorhome to access the valves. Make sure there is ample room to open the valves safely.**

### Maintenance:

Occasionally while the jacks are fully extended, wipe dirt from the jack rod. This will help lengthen the life of the jacks. This can vary from the amount and type of usage of the jacks. Dexron III will serve as a solvent as well as a lubricant. Occasional oil or grease on the extended jack ram is normal and aids in the lubrication of the ram. It helps to learn the sound of the normal pumping and gurgling sounds of the pump when it is low on fluid.

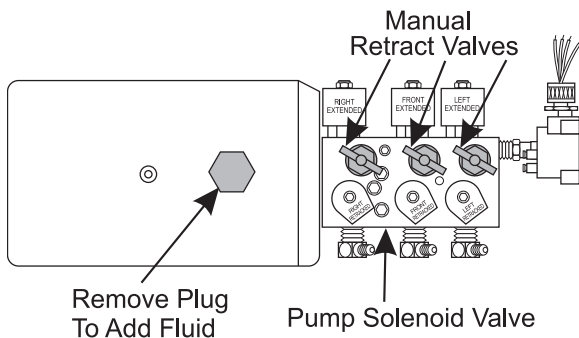

### Calibration:

The transmitter module may require recalibration to ensure an accurate level is obtained. The recalibration procedure requires two persons for convenience and accuracy. This should only be performed by qualified service technicians.

### Adding Fluid:

1. An indication of a system needing fluid is a chime sounding when turning corners. Use Dexron III automatic transmission fluid.
2. Extend any jacks 6 inches from the full retracted position. All other jacks should be fully retracted.
3. Unscrew the reservoir cap from the top of the pump.
4. Turn the ignition switch to the ON position. Turn the power ON rocker switch. Open the window so the bong alarm is audible from outside the motorhome. Slowly fill the reservoir with fluid until the bong alarm stops sounding.
5. Replace the reservoir cap.
6. Turn the ignition switch and the remote panel OFF.

**ENGINE - GENERAL  
INFORMATION**

The diesel engine operates differently from the conventional gasoline engine. Gasoline engines control engine speed using a butterfly throttle plate controlling air/fuel mixture inlet flow. As the throttle plate opens, vacuum created by the piston velocity draws the metered fuel/air charge into the combustion chamber, then ignites from a controlled electric ignition source. Closing the throttle plate limits the fuel/air supply, slowing engine speed, increasing intake manifold vacuum.

The diesel engine in the motorhome controls engine speed by varying fuel supply only. No throttle plates are used. An exhaust driven turbine system (turbocharger) compresses the fresh air supply into the engine. The fuel is injected under pressure into the combustion chamber. Ignition of fuel/air charge occurs from heat generated by rapid high compression. The turbo boost gauge registers amount of intake manifold compression measured in lbs./in<sup>2</sup>. Therefore, no intake manifold vacuum exists.

Diesel engine RPM (revolutions per minute) operating speeds are generally much lower than that of the gasoline engine. Peak torque and horsepower output values occur at much lower engine speeds. Idle speeds between the two engine types are similar, however maximum engine speeds are quite different. The gasoline engine generally is not regulated to a maximum engine speed. The maximum engine speed on a diesel engine is controlled by an engine speed governor set by the engine manufacturer.



**WARNING: Do not operate a diesel engine where there are or can be combustible vapors. Vapors can be drawn through air intake system and cause engine acceleration and over-speeding, resulting in fire, explosion and extensive property damage. Numerous safety devices are available, such as air intake shut-off devices, to minimize risk of over-speeding where an engine (due to its application) might operate in a combustible environment, such as fuel spills or gas leaks. Equipment owner and operator is responsible for safe operation of engine. Consult your engine authorized repair location for future information.**

The maintenance guidelines found in the Cummins O & M manual is recommended for the engine. When followed it will help with a longer life, better performance and more cost efficient operations. A good maintenance schedule begins with a daily awareness of the engine and its various systems.

The engine is equipped with an intake manifold grid heater. The grid heater helps engine starting in cold weather. Intake manifold air temperature is monitored by the Electronic Control Module on the engine. If intake manifold temperature is below specified level (approximately 40° F.) manifold grid heater will be activated. Grid heater activation is indicated by the WAIT TO START indicator lamp.

**ISC ENGINE**



**WARNING: Use of ether starting fluids may cause an explosion upon grid heater activation.**

---

## **ENGINE STARTING PROCEDURE (ISC Normal)**

With throttle in idle position turn ignition to the ON position allowing WAIT TO START lamp to extinguish. Turn key to the start position. When the engine is started the grid heater will again energize for a time period determined by the intake air temperature and the fuel temperature. Allow engine to idle with no load for 3-5 minutes. The engine coolant temperature should be up to normal operating range (140° F / 60 ° C to 212° F / 100° C) before operating engine under full throttle.



**NOTE: It is not recommended to idle the engine for long periods of time. This will simply waste fuel and annoy neighbors. Consistent periods of long idle may cause damage to the engine.**

---

## **COLD WEATHER STARTING PROCEDURE**

The engine block heater may need to be plugged in 2 to 3 hours prior to starting. The engine block heater is rated at 1500 watts, 110 Volts AC and requires the motorhome be plugged into shore power or have the generator running. It is not necessary to leave the block heater plugged in for long periods of time. The block heater requires about 13 amps to operate.

---

## **OIL RECOMMENDATIONS (ENGINE)**

The maintenance guidelines found in the Cummins O & M manual is recommended for the engine. When followed it will help with a longer life, better performance and more cost efficient operations. A good maintenance schedule begins with a daily awareness of the engine and its various systems.

A high grade 15W-40 multiviscosity heavy duty lubricating oil meeting Cummins Engineering Specification CES 20071 or CES 20076, American Petroleum Institute (API) specification CH-4 which can be used as an alternative to CES 20071 is recommended. Lubricating oils meeting API CG-4 specifications may be used at a reduced drain interval. Monaco Coach uses Pennzoil 15W-40 heavy duty engine lubricating oil that meets Cummins specifications. A critical factor in maintaining engine performance and durability is the use of high grade multigrade lubricating oil and strict adherence to the maintenance service intervals.

A straight weight or monograde lubricating oil is not recommended. Shortened drain intervals may be required as determined by a close monitoring of the lubricating oil condition by means of a oil sampling program. The use of oil analysis to extend drain interval is not recommended. There are numerous variables which is the basis of the recom-

mendation.

Synthetic oils API category III specifications are recommended for extreme cold temperatures only.

Low viscosity oils used for winter operations will aid in starting. Synthetic oils or oil with adequate low temperature properties used for Arctic operations, where the engine can not be kept warm when shut down, will aid in starting.

The use of synthetic oils should not be used to extend drain intervals. Extended oil change intervals can decrease engine life and possibly affect the engine warranty.

Oil additives should not be used unless the oil supplier or oil manufacturer has been consulted and provided positive evidence or data establishing satisfactory performance in the engine.

### **Oil Function of Engine Oil:**

If a lubricating oil is to work in an engine it must be capable to perform various functions. Lubrication of the moving parts is the primary function. The lubricating oil should be able to form a film between metal surfaces preventing metal to metal contact and reducing friction. When you have a metal to metal contact, friction heat is generated. Welding of the part can occur and metal transfer will result in scuffing or seizing. The film of oil contacting the surfaces will provide cushioning and shock dampening as well.

Cleaning is another function. The oil should perform as a cleaner in the engine by flushing contaminants from critical components. These contaminants should be removed in the filtration system or during the course of an oil change. Oil will provide a protective barrier to prevent corrosion of non-like metals.

Internal components of the engine require cooling. The primary coolant system cannot provide this cooling. Oil will transfer heat by contacting the various components then transferring to the primary cooling system at the oil cooler. The uneven surfaces are filled to react as a combustion seal within the cylinder liner and other internal components.

### **Synthetic Engine Oil:**

In extreme environments where ambient temperatures can be as low as -45° C (50° F) a petroleum based oil will not perform satisfactorily in diesel engines. Synthetic oils were developed for these type applications. These synthetic oils are a blend from ester and/or hydrocarbon based oils. These base oils are produced by chemically reacting lower molecular weight materials to manufacture lubricants of desired properties. All synthetic based oils must meet the API category III classifications and SAE viscosity grades. Synthetic oils and petroleum based oils should never be mixed.



### **Viscosity:**

Viscosity is simply a measure of resistance of molecule layers moving relative to an adjacent layer. All fluid viscosity are affected by temperature. A multigrade lubricating oil tends to be less sensitive to temperature changes due to formulation. Lubricating oils are generally selected for use with viscosities appropriate for the expected operating temperature. The correct selection of a lubricating oil of correct viscosity is critical for optimum performance. Some effects of incorrect viscosity when the oil is too thick range from difficulty in starting to increasing fuel consumption and reducing power output. When the oil is too thin, oil consumption is increased as well as wear from the metal to metal contact. This will also increase engine noise.

Low temperature viscosity specifications are identified by a “W” (winter). High temperature viscosity that meets the 100° C (212° F) requirements have no suffix. When a lubricating oil meets both high and low temperature requirements they are classified as multi-viscosity or multigrade.

### **Routine Maintenance Recommendations:**

1. Check oil level daily.
2. Replace oil filter at every oil drain interval.
3. Cummins Engine Company, Inc. recommends the use of high quality, API (American Petroleum Institute) licensed CH-4 or CES20071, 15W-40, multiviscosity oil or premium oil.
4. The recommended oil drain interval is defined by the API oil performance classification and the engine duty cycle. Refer to the Cummins Operation and Maintenance Manual for complete details.

---

### **Oil Recommendations Cold Weather**

It is possible to operate diesel engines in extremely cold environments. The engine should be properly prepared and maintained. The correct lubricants, fuels and coolant **MUST** be used for the cold weather range for which the motorhome is being operated. Cold weather operation can be defined in two categories: Winterize and Arctic.



**NOTE: Refer to the Operations and Maintenance Manual for more detailed information.**

#### **WINTERIZE (32° to -25° F) (0° to -32° C)**

Use a 50 antifreeze / 50 water coolant mixture, use multi-viscosity oil meeting Cummins specifications and fuel to have maximum cloud pour points 10° F (6° C) lower than the ambient temperature in which the motor home operates.

#### **ARCTIC (-25° to -65° F) (-32° to -52° C)**

Use a 60 percent antifreeze / 40 water coolant mixture, use oil meeting Cummins specifications and fuel to have maximum cloud pour points 10° F (6° C) lower than the ambient temperature in which the motorhome operates.

General guidelines for shutting the engine down are fairly simplistic. Allow the engine to idle 3 to 5 minutes after a full load operation. This allows adequate cool down of pistons, cylinders, bearings and turbocharger components. Under normal driving conditions exiting the highway is generally lighter engine operation and the need for the 3 to 5 minutes is not necessary.

## ENGINE SHUTDOWN

When the motorhome has been sitting for extended periods, 30 days or more, verify all the fluid levels are correct. Follow the normal starting procedures. If the oil pressure gauge does not register within 15 seconds, shut off the engine immediately to avoid damage. Consult the Cummins Operations and Maintenance Manual for guidelines on troubleshooting low oil pressure, or contact a qualified service technician. Allow the engine to idle for 3 to 5 minutes before operating under a load.

## ENGINE SHUTDOWN - Extended

A fully formulated antifreeze or coolant containing a precharge of Supplemental Coolant Additives (SCA) is recommended. The use of either will significantly simplify coolant system maintenance. The difference between a fully formatted antifreeze and a fully formatted coolant is the percentage of water. Both contain balance amounts of antifreeze, SCA, buffering compounds and a percentage of good clean quality water. The antifreeze of coolant must meet ethylene glycol or propylene glycol recommendations. A good clean quality water in a 50/50 ratio (40 to 60 percent working range) mixed with fully formatted antifreeze will provide protection from -34° F to 228° F. The 50/50 mix ratio must be premixed prior to being put in the system. Placing antifreeze and water in the cooling system is not recommended. Consult the O&M manual for more details.

## COOLANT



**NOTE: An over concentration of antifreeze, or the use of high silicate antifreeze, can cause damage to the coolant system and engine. Antifreeze is essential in every climate.**

The coolant fluid freeze point should be checked with every oil change interval at 15,000 miles, 500 hours or 6 months, whichever comes first. Also change the coolant filter at the same interval unless SCA concentration is over three units. The coolant should be drained and flushed at 6000 hours or 2 years of service, whichever comes first.

### Engine Coolant Reservoir:

A “see-through” plastic reservoir, similar to the familiar windshield washer jar, is connected to the radiator by a hose. As the motorhome is driven, coolant is heated and expands. A portion of fluid displaced by this expansion flows from the radiator into the reservoir tank. When the engine is stopped, and coolant cools and contracts, displaced coolant is drawn back in the radi-



tor by a vacuum. Thus, the radiator is kept filled with coolant to the desired level at all times, resulting in increased cooling efficiency the coolant level should be at or above the appropriate mark on the reservoir tank when the system is cold.

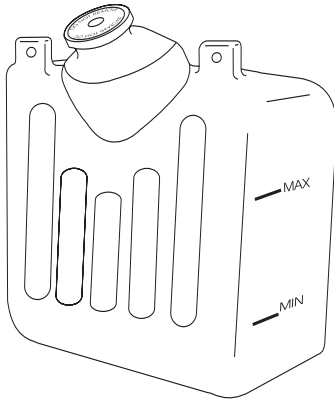

- Check the coolant level daily or when refueling.
- Drain and flush the coolant system every 60,000 miles or two years and refill with a heavy-duty coolant (50/50 mix of water and anti-freeze).
- If the coolant is below the MIN mark the low coolant alarm will sound and the low coolant light will appear on the dash. You will need to stop and check for coolant loss before driving.
- The coolant level to remain between the MAX and MIN level in the reservoir.

### Routine Maintenance Recommendations

1. Check the SCA concentration level every 15,000 miles/6 months.
2. Change the coolant filter every 15,000 miles/6 months.
3. Drain and flush the system every 240,000 miles/2 years, and refill with a heavy-duty coolant (50/50 mix of water and antifreeze).
4. Always use antifreeze. In addition to freeze protection, antifreeze is essential for overheat and corrosion protection.
5. The supplemental coolant additive (SCA) is required.
6. Freeze point should be measured every 15,000 miles/6 months.

### Coolant - Additive (SCA)

Fully formulated products contain SCA and are required to protect the cooling system from fouling, solder blooming and general corrosion. The cooling filter is required to protect the coolant system from abrasive materials, debris and precipitated coolant additives.

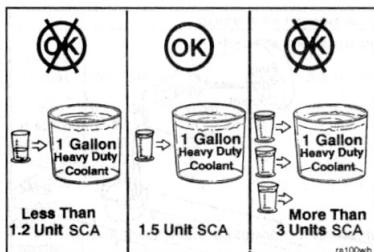

Supplement coolant additives, or equivalent, are used to prevent liner pitting, corrosion and scale deposits in the cooling system. Use the correct Fleetguard coolant filter to maintain the recommended SCA concentration in the system. Maintain the correct concentration by changing the service filter at each oil drain interval.



**NOTE:** The correct filter is determined by the total cooling system capacity and oil drain interval. Refer to the Coolant Capacity Specifications in this section.



**CAUTION:** Insufficient concentration of the coolant additives will result in liner pitting and engine failure. The SCA concentration must not fall below 1.2 units or exceed 3 units per gallon of cooling system capacity.

Use the correct Fleetguard coolant filter to maintain the recommended SCA concentration in the system. Maintain the correct concentration by changing the service coolant filter at each oil drain interval. The oil pressure gauge, temperature gauge, warning lamps and other safety lamps should be checked daily to ensure proper operations.



**NOTE:** The correct filter is determined by the total cooling system capacity. If you have any questions refer to the Cummins manual.



**NOTE:** The engine does not require a “break-in” procedure.

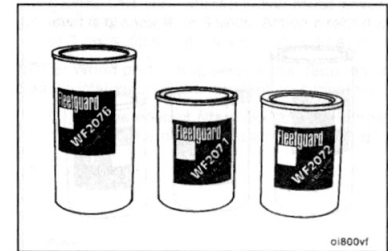
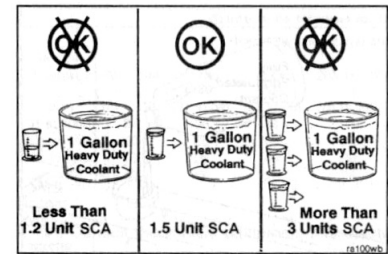

Low sulphur #2 diesel fuel or #1 and #2 commercial winter blend diesel fuels are the most common commercially available and recommended for use. The Cummins Engine Company Inc. recommends the use ASTM #2D fuel. The use of #2 diesel fuel will result in optimum engine performance.



**WARNING:** Do not mix gasohol with diesel fuel. This mixture can cause an explosion.



**NOTE:** Due to the precise tolerances of diesel injection systems, it is extremely important that fuel be kept clean and free of dirt or water. Dirt or water in the system can cause severe damage to both the fuel pump and the fuel injector. Fuel additives for lubricity are not recommended. There are numerous diesel fuel additives to help remove moisture from fuel, prevent microbe growth and to prevent freeze-up during cold weather. Any fuel additives product should show supporting data for performance and benefits. Engine failures caused by incorrect fuel are not covered under warranty.

## FUEL SYSTEM

Auxiliary braking devices are devices designed to supplement your standard wheel braking system. The devices are not designed to stop the motorhome completely. The proper use of an auxiliary braking device can save in costly service brake repairs. The braking devices will assist in controlling the motorhome speed.

The Exhaust Brake system, used routinely at normal exhaust operating temperatures, is virtually maintenance free. Some contributing causes which can result in failures with the exhaust brake include moisture, dirt, carbon and improper usage.

Starting the engine and idling for short periods of time is not recommended. Moisture is created within the engine and the exhaust system during cold

## BRAKE - ENGINE

startups. When normal operating temperatures are not obtained moisture may get trapped in the valve housing resulting in rust, leading to insufficient operation of the exhaust brake.

Some problems you may encounter with the exhaust brake include, but are not limited to, will not activate or deactivate, intermittent on/off operations or actuates with the switch off. These are commonly related to electrical symptoms. Slow operations or delays in operations, as well as limited performance, are mechanical symptoms. You should refer these problems to your dealer for diagnosis.

---

## **BRAKE - EXHAUST (Isc Engine)**

Pac Brake exhaust retard is such an auxiliary braking device attached directly to engine turbocharger. The Pac Brake is activated when dash switch is "ON" and throttle is "RELEASED." While driving with cruise control on, it will require tapping service brakes to disengage cruise control. Pac Brake foot switch will not disengage cruise control. A valve inside brake then moves to restrict flow of exhaust gases, causing an increase of back pressure within engine.

Increased back pressure quickly slows down engine, resulting in powerful braking performance. Amount of braking power you will develop when Pac Brake is on is relevant to engine speed (RPM). Higher RPM will have more retarding power. Certain conditions may require down shifting to generate adequate RPM for maximum retarding.

A Pac Brake wired to electronically controlled transmission will usually provide converter lockup in gears 2 through 6, meaning brake will activate automatically when throttle is released. Once on, brake will control existing road speed and/or slow sufficiently so Allison Transmission will automatically down-shift, if necessary, to calibration pre-select mode.

---

## **EMERGENCY PROCEDURES - JUMP STARTING**

When using jumper cables to start the engine make sure the cables are connected in parallel. That is positive (+) to positive (+) and negative (-) to negative (-). Always connect your positive (+) before the negative (-) and disconnect the negative (-) before the positive (+) to prevent arcing. When using an external electrical source to start the engine shut the disconnect switch to OFF position.

Batteries can emit explosive gases. Always ventilate the battery compartment prior to any work or service to the batteries. Extinguish all smoking material and keep all open flame and spark producing devices away from battery area.

In the event of a roadside emergency, contact the nearest Cummins Center or phone 1-800-DIESELS for Cummins Customer Assistance Center.

## TRANSMISSION - Shift Selector

The Allison World transmission incorporates the World Transmission Electronic Control (WTEC) system. The system is comprised of five major components connected by a wiring harness: the electronic control unit (ECU), engine throttle position sensor, three speed sensors, remote shift selector (keypad) and the control module. The ECU will process information received from the throttle position sensor, speed sensor, pressure switch and shift selector to activate solenoids on the control module in the transmission. The solenoids control oncoming and off going clutch pressure to provide closed loop shift control. This is accomplished by matching RPM during a shift to an established desired profile within the ECU.

The system is monitored within the first 30 seconds of each engine start. This is referred to as “auto detect.” Auto detect searches for presence of data inputs or transmission components. The auto detect enables the ECU functional or diagnostic response to the items which are detected.

Another feature of the transmission is the ability to “learn” or “adapt.” The electronic control system optimizes shift quality by using “Adaptive Shifting.” A wide variety in shifting under varied conditions will be required before optimizing the shift quality. Generally five typical shifts of a shift type is needed for shift calibration.

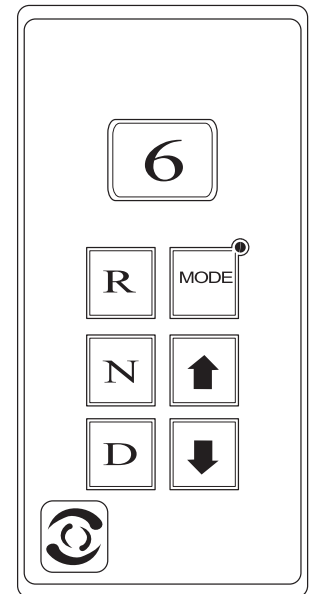

The range selection is accomplished via the remote push button selector. The selector is simplistic in appearance. The controls are R, N, D, arrow up, arrow down, MODE buttons and a digital display window. Under normal operations the “D” button is pressed and the digital display shows the highest forward range attainable for the shift selection in use. The digital display window will also indicate codes for abnormal conditions and can even be a useful troubleshooting aid. When the ignition is turned ON the display should be visible. This display indicates the presence of neutral start command. If this display indication is not visible there is no power to the selector and may indicate electrical problems with the batteries.

- Digital display window enables information requested to be easily read.
- Select the Reverse gear by pressing “R”.
- Select NEUTRAL by pressing “N”. The area around the “N” button is a raised ridge so the driver can orient his hand to the push buttons by touch, without looking at the display.
- Select DRIVE range by pressing “D”. The highest forward gear will appear on the SELECT display and the transmission will shift to the starting gear.
- The UPSHIFT and DOWNSHIFT arrow buttons are used to select a higher (if not in “D”) or lower (if not in “1”) forward range. These buttons are not functional in NEUTRAL or REVERSE. One press changes the range selected by one range. If the button is held continuously the selected range will continue to change up or down until the button is released or until the highest/lowest possible range of gears is selected.

- The MODE button will enable secondary shift point to be selected. This is commonly referred to as “Economy”. It is further used by the service technician to access diagnostic codes when troubleshooting. The diagnostic circuitry must be enabled to display.

---

## Transmission -Check Light

The electronic control system is programmed to inform the operator of a problem with the transmission system and automatically take action to protect the operator, motorhome and transmission. When the Electronic Control Unit (ECU) detects a DO NOT SHIFT (DNS) condition the ECU restricts shifting, turns the CHECK TRANS light on the instrument panel and registers a diagnostic code.



**NOTE: For some problems, diagnostic codes may be registered without the ECU activating the CHECK TRANS light. An Allison Transmission authorized service outlet should be consulted whenever there is a transmission related concern. They have the equipment to check for diagnostic codes and to correct problems which arise.**

Each time the engine is started the CHECK TRANS will light, then turn off after a few seconds. This momentary lighting is to show that the status light circuits are working properly. If the CHECK TRANS light does not illuminate during start up, or if the light remains on after start up, the system should be checked immediately.

Continued illumination of the CHECK TRANS light during vehicle operation (other than start up) indicates that the ECU has signaled a diagnostic code. Illumination of the CHECK TRANS light is accompanied by a flashing display from the shift selector. The shift selector display will show actual range attained and the transmission will not respond to shift selector requests.

Indications from the shift selector are provided to inform the operator that the transmission is not performing as designed and is operating with reduced capabilities. Before turning the ignition off, the transmission may be operated for a short time in the selected range in order to “limp home” for service assistance. Service should be performed immediately in order to minimize potential for damage to the transmission.

When the CHECK TRANS light comes on and the ignition switch is turned off the transmission will remain in N (Neutral) until the condition causing the CHECK TRANS light is corrected. Generally, while the CHECK TRANS light is on, upshifts and downshifts will be restricted and direction changes will not occur. Lever and push-button shift selectors do not respond to any operator shift request while the CHECK TRANS light is illuminated. The lockup clutch is disengaged when transmission shifting is restricted, or during any critical transmission malfunction.

### **Diagnostic Codes**

The diagnostic codes are numerical representations of malfunctions in the transmission operations. Each code is a two digit main code and a two digit sub code. The codes, when detected, are logged in the ECU memory. These codes will fall in two classes: active and inactive. Active codes are codes currently effecting the ECU process. Inactive codes are retained but may not effect the ECU process. The diagnostic mode must be entered. A maximum of five codes, D1 to D5, may be listed at one time. The highest priority code will be listed in D1. The MODE button will enable selection of sequential codes.

- Enable Diagnostic Code Selection Display.
- Stop the motorhome at a safe location.
- Apply the parking brake.
- Simultaneously press the up and down arrows twice to enter the stored codes. The first time the arrows are pressed will indicate the oil level sensor information.
- The codes will display one digit at a time.
- The mode button is pressed to scroll through the codes.
- Any code obtained should be noted and reported to an Allison Service Center for evaluation and possible repair.
- Inactive codes can be cleared by holding the MODE button for approximately 3 seconds. Some codes are self clearing while others will require service or ignition cycles to clear.

The Allison MT Series requires minimum maintenance. Careful attention to the fluid level and the connections for the electronic and hydraulic circuits is very important.

For easier inspection the transmission should be kept clean. Make periodic checks for loose bolts and leaking fluid lines. Check the condition of the electrical harnesses regularly. Check the engine cooling system occasionally for evidence of transmission fluid which would indicate a faulty oil cooler. Report any abnormal condition to an Allison dealer.

### **Prevent Major Problems**

Help the WTEC III control system oversee the operation of the transmission. Minor problems can be kept from becoming major problems if you notify an Allison Transmission distributor or dealer when one of these conditions occur:

1. The shifting feels odd.
2. The transmission leaks fluid.
3. There are unusual transmission-related sounds (changes in sound caused by normal engine thermostatic fan cycling, while climbing a

---

### ***Transmission - Periodic Inspection***



long grade with a heavy load, have been mistaken for transmission-related sounds).

4. The CHECK TRANS light comes on frequently.

### **The Importance of Proper Fluid Levels**

The transmission fluid cools, lubricates and transmits hydraulic power. It is important that the proper fluid level be maintained at all times. If the fluid level is too low the converter and clutches do not receive an adequate supply of fluid. If the fluid level is too high the fluid can aerate. Aerated fluid can cause the transmission to shift erratically or overheat.

The MT Series oil level sensor (OLS) allows the operator to obtain an indication of sensor fluid level from the keypad shift selector. Frequently check for the presence of oil level diagnostics in the transmission. If the OLS has not been detected, troubleshooting of the OLS circuit is required. This will have to be performed by an Allison Service Center. After the OLS circuit is repaired ensure that reset of the “auto detect” or manual selection of the OLS function, using the Pro-Link, has been accomplished.

### **Fluid Level Check with the Keypad**

- Park the motorhome on a level surface, place the transmission in “N” and set parking brake.
- The transmission should be at normal operating temperature.
- The motorhome should be stationary for approximately two minutes to ensure fluid is stabilized.
- Simultaneously press the arrow up and arrow down buttons one time.
- The delayed fluid level check will display in the digital display window.

The display will be one character at a time. The “o,L” represents oil level check mode. This will be followed with fluid level indication readings. The “o,K” indicates a correct fluid level. Reading between the OLS and the dipstick may not agree because the OLS compensates for fluid temperatures. Abnormal indications of the OLS will be “Lo” representing a low fluid level, “HI” for a high fluid level or “LO” for invalid information and system problems. All indications will be followed by numeric values. The “LO” and “HI” followed by the numeric value represents the quarts of fluid required for the system. The invalid code numbers represent specific symptoms.

### Common Oil Level Fault Codes:

- 0,5 settling time too short.
- 5,0 speed RPM too low.
- 5,9 speed RPM too high.
- 7,0 sump temperature too low
- 7,9 sump temperature too high
- 9,5 OLS FAILURE

Exit the fluid level display by pressing any range button on the keypad.



**NOTE: To correctly check the transmission fluid level using the dipstick the transmission fluid must be at operating temperature. The oil level sensor method of checking the fluid level compensates for transmission fluid temperature between 60°C - 104°C (140°F - 220°F). Any temperature below 60°C (140°F), or above 104°C (220°F) will result in an Invalid for Display condition.**

Any fluid meeting DEXRON-III specifications are acceptable for use in the transmission. Transmission performance, reliability and durability are important influences in the type of fluids used. Change the fluid internal filters after the first 8000km (5000 miles). The dipstick/oil fill is located between the engine and transmission underneath the engine access door in the bedroom. Change the transmission fluid and internal filters every 40,000km (25,000 miles) or 18 months, whichever occurs first.

**TRANSMISSION  
LUBRICATING  
FLUID**

### Fluid and Internal Filters Change Interval Recommendations

The fluid and internal filters may require changing earlier depending on the severity of operating conditions. The fluid must also be changed whenever there is evidence of dirt or high temperature conditions as indicated by discoloration, strong odor or fluid analysis. Local conditions, severity of operation or duty cycle will dictate more or less frequent service intervals.

### Manual Check Procedures:

The concept of a cold check is to determine adequate fluid level for safe operating until hot check can be performed.

### *Cold Check*

- Park the motorhome on a level surface using the service brakes.
- The engine is operated at a low idle. Put the transmission in N (Neutral).
- Apply the parking brake and chock the wheels to prevent the motorhome from moving.
- Allow the engine to run at idle (500-800 rpm) for one minute.
- Apply the service brakes and shift to D (Drive), then to N (Neutral) and next to R (Reverse) to fill the system. Finally shift to N (Neutral) and release the service brakes. Allow the engine to continue to run at idle



(500-800 rpm).

- Remove the dipstick and wipe clean. Reinsert the dipstick fully into the tube and remove to check fluid level. Repeat this to verify the reading if needed.
- Safe operating level is anywhere within the COLD CHECK band on the dipstick. The fluid level is sufficient enough to operate until a HOT CHECK can be run.
- If the level is not within this band add or drain the fluid as necessary to bring the level to the middle of the COLD CHECK band.
- Perform the HOT CHECK the first opportunity after reaching normal operating temperatures (160°-200° F / 71°-93° C).

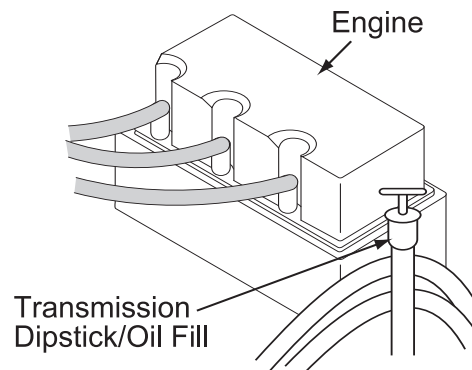

**CAUTION: Low or high fluid level can cause overheating and irregular shift patterns. These conditions can damage the transmission if not corrected.**

---

### **Hot Check**

- The fluid level rises as the temperature increases. The fluid must be hot to ensure an accurate check.
- Be sure the fluid has reached normal operating temperature (160°-200° F/71°-93° C). If a transmission temperature gauge is not present check the fluid level when the engine water temperature gauge has stabilized and the transmission has been operated under the load for at least one hour.
- Park the motorhome on a level surface and shift to N (Neutral). Apply the parking brake and allow the engine to idle (500-800 rpm).
- After wiping the dipstick clean, check the fluid level. Safe operating level is anywhere within the HOT RUN band on the dipstick.
- The width of the HOT RUN band is approximately 1 quart of fluid at normal temperature range.
- If the level is not within this band, add or drain the fluid as necessary to bring the level within the HOT RUN band.
- Be sure that the fluid level checks are consistent. Check the level more than once. If the readings are not consistent check to be sure that the transmission breather is clean and not clogged. If the readings are still not consistent, contact the nearest Allison distributor or dealer.

**FUEL TANK**

The diesel fuel tank is made of 160 thousands aluminum. The capacity of the tank is 118 gallons. The engine pickup tube is cut at a 45 degree angle to allow good flow to the engine.



**NOTE: If the coach has been stored for any length of time you should check the vent for blockage. It is not uncommon for insects to plug the vent tube. If the tank appears to be pressurized the vent tube may be blocked. To inspect the vent tube check on the roadside of the fuel tank, near the bottom.**

**Routine Maintenance Recommendations:**

1. Change the fuel filter at every oil change interval.
2. Change the fuel-water separator filter every 12-18 months or every 25,000 miles.

Fuel/Water separator is located in rear engine compartment on left and rear of frame. If “water in fuel” light is illuminated, fuel filter will need to be drained. Shut off engine and open drain valve. Turn valve counter-clockwise approximately 1-1/2 to 2 turns until draining occurs. Drain fuel/water separator of water and sediment until clear fuel is visible. Turn valve clockwise to close drain valve.

In the event the ISC engine runs out of fuel, the lift pump on the fuel pump will run for approximately 1 minute with the ignition ON. The ignition may have to be turned on and off several times before attempting a start. If unable to restart, contact the nearest Cummins Center or phone 1-800-DIESELS for Cummins Customer Assistance Center.

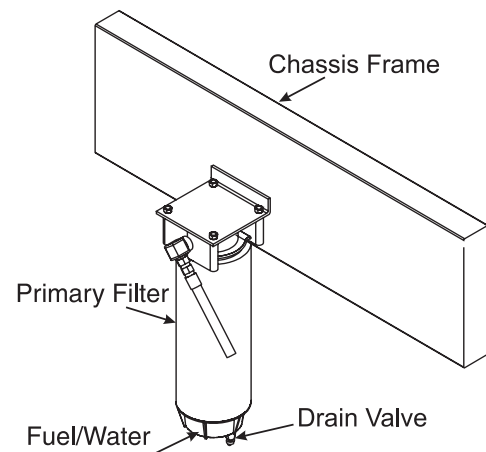
**FUEL/WATER SEPARATOR  
(ISC Engine)**

The Centroid fuel sender has no moving parts. It works by measuring capacitance, an electrical property, between its inner and outer tubes in the tank. The more fuel between the tubes, the higher the reading. Electronics in the hockey-puck head of the sender convert the capacitance to current to drive the fuel gauge.

**Connections:****The Centroid sender has four connections:**

- Positive and Negative: Battery voltage to run the electronics in the sender head.
- Send: Connects to the Send terminal of the gauge on the dash.

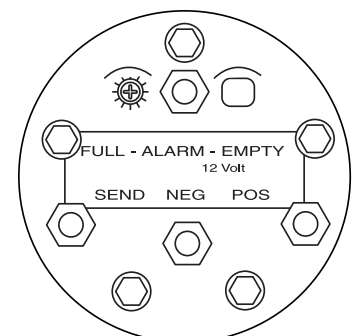
**FUEL SENDING UNIT**

- Alarm: Makes a connection internally to the Negative terminal when the low alarm fuel level is reached (when gauge is reading about 1/8 tank). This turns on the alarm light on the dash. It is not adjustable.

**Adjustments:**

**The Centroid sender has two adjustments:**

**Empty:** Adjusts for length of sender. It has been set at the factory and covered with a sealant. It should not be changed.

**Full Adjustment:** The full adjustment can be used to correct for slight differences between fuel meters. During installation it has been calibrated for your meter and should not need readjustment.

The correct adjustment technique, with a full tank of fuel, is to start with the full adjustment screw completely clockwise. This should cause the reading to be above full. Adjust slowly counterclockwise until the full mark is reached. The intent is to always adjust downscale rather than upscale.

**Troubleshooting:**

- A. Electronic output.** The sender has a transistorized output. This prevents an ohmmeter from getting a correct reading of its output resistance.
- B. Fuel Only:** The sender will not work correctly in conducting fluids such as water (it will read above full all the time in water). One possibility, when you have a constant above-full reading, is that you have water at the bottom of the fuel tank.
- C. Contact Centroid:** Probably 90% of the returns Centroid tests work okay on the bench. If you have incorrect readings contact Centroid (telephone: 800-423-3574, or (preferable) fax: 904-423-3709) with your symptoms. You will be provided with a short “fill in the blanks” troubleshooting test appropriate to your sender. It is easier to find the problem that way than after the sender has been removed from the system, since the problem is not necessarily with the sender.

---

## HYDRAULIC SYSTEMS (ISC)

The motorhome uses an engine driven hydraulic pump to operate both the power steering system and the engine hydraulic cooling fan system. The dual stage hydraulic pump uses one half of the pump to supply pressurized hydraulic fluid to the power steering gear assembly. The other half of the pump supplies pressurized hydraulic fluid to the engine cooling fan motors. The hydraulic system uses the same fluid for both systems sharing one common reservoir. The hydraulic fluid used is an automatic transmission fluid (Dexron3) which has a wide ambient temperature operating range.



**CAUTION: If ambient temperatures approach 0° Fahrenheit, Pennzoil Arctic Blue hydraulic fluid or equivalent hydraulic fluid should be used. Using incorrect hydraulic system fluid weights in cold or arctic temperatures will raise the hydraulic system operating pressure and may damage the hydraulic cooler.**

The hydraulic pump creates pressure by meshing sets of gears together inside a close tolerance housing. A filtered supply of hydraulic fluid from the hydraulic reservoir enters the intake side of the pump. The meshing gear assembly “squeezes” the oil through the pump to the output side delivering the pressurized fluid to the power steering gear and the switching valve of the engine cooling system. Each half of the pump is equipped with an internal bypass pressure relief spring. If the hydraulic pressure should exceed the specified pressure limit, the internal bypass relief valve will be forced open to keep the hydraulic fluid at operating pressure. The hydraulic pressure generally is not rated in psi but is rated in the term bar. One bar is equivalent to approximately 14.5 psi. Hydraulic system pressures with a system at no load may be as low as eight bar on the output side of the pump. This is due to the hydraulic fluid flow of the pump. When a load is placed on the hydraulic pump such as turning the steering wheel, hydraulic fluid flow slows from hydraulic fluid restriction and creates pressure.

This may be understood as a faucet with a garden hose attached. Crimping the hose with the faucet on will create pressure from the restriction. This principal applies to the hydraulic system. The hydraulic pump is the supply, the load would be the power steering gear or the hydraulic fan motor. Hydraulic system pressure at full load can exceed 130 bar or 2000 psi. Hydraulic system pressure falls dramatically after the load. The return line pressure may be as low as six to eight bar. The fluid enters the hydraulic cooler where the heat is dissipated.

---

## **Hydraulic Pump**

The hydraulic cooler is an important part in the hydraulic system. This helps keep the hydraulic fluid from overheating. When a load is placed on the hydraulic system, heat is created in the fluid. The hydraulic pump builds pressure creating heat in the fluid. The restriction from the loads applied also creates heat. This heat must be dissipated to keep the hydraulic fluid from overheating and breaking down. After the fluid is cooled the fluid is filtered before returning to the reservoir.

Care must be used when starting an engine in very cold or arctic climates. As with any oil, lower temperatures thicken the oil. Hydraulic system pressures increase due to the thickness of the fluid. Even though the hydraulic pump is equipped with pressure relief valves the thick oil on the return line can exceed the operating pressure of the hydraulic cooler.

---

## **Hydraulic Cooler**

## **Hydraulic Fan System**

The hydraulic fan drive system cools the radiator, charge air cooler, hydraulic fluid cooler, transmission cooler and the dash air conditioning condenser. The components of the hydraulic fan system are: hydraulic reservoir, filter, pump, fan motor, switching valve and thermostatic valve. The cooling fan speed is proportional to engine speed and radiator temperature. When radiator temperature rises above 185° F, the wax thermostatic valve slowly closes off the bypassing hydraulic fluid from the switching valve. A spool valve begins to move in the switching valve. This directs the pressurized hydraulic fluid to the fan motor. The higher the radiator temperature, the further the spool valve is moved in the switching valve, providing a higher volume of pressurized hydraulic fluid to the fan motor. Fan motor speed is increased to meet the demand for cooling. The action of the thermostatic valve is designed to move the spool in the switching valve to ramp up fan motor speed. This design saves horsepower and increases fuel mileage by precise control of hydraulic fan motor speed. The fan motor will increase in speed when the motorhome is ascending long hills or operating in high ambient temperatures. It is normal for the fan to “roar” when it is operating. Fan motor speed and engine rpm are approximately the same with the switching valve at full engagement.

---

## **Thermostatic Valve**

The wax filled thermostatic valve is mounted at the top of the radiator sensing coolant temperature. The thermostatic valve controls the action of the switching valve. When the radiator is cool the hydraulic fluid is allowed to flow through the inlet and outlet ports of the thermostatic valve and return to the hydraulic reservoir. As the coolant temperature inside the radiator rises to approximately 185° F the wax inside the thermostatic valve begins to melt and expand. This begins to restrict hydraulic fluid flow through the thermostatic valve. The restricted hydraulic fluid pressure then begins to move the internal spool valve of the switching valve. This process will continue until coolant temperature inside the radiator reaches approximately 199° F. At this temperature hydraulic fluid flow through the thermostatic valve is stopped, moving the spool valve to full open position.

---

## **Switching Valve**

The switching valve is mounted to the fan motor. The switching valve controls the direction of high pressure hydraulic fluid flow. High pressure hydraulic fluid comes from the hydraulic pump to the switching valve and is returned back to the reservoir. The thermostatic valve directs the fluid to the spool valve in the switching valve. When the radiator is cool, pressurized hydraulic fluid will bypass the fan motor and return to the fluid reservoir. As radiator temperature rises, the thermostatic valve signal is slowed or stopped to the switching valve. High pressure fluid is then directed to the fan motor, cooling the radiator.

**Fan Motor**

The fan motor is driven by hydraulic fluid pressure from the switching valve. The fan motor works on the same mechanical principal as a hydraulic pump, only the mechanical principal when applied to the fan motor is reversed. Instead of creating hydraulic pressure by meshing gears together in a close tolerance housing, the fan motor receives hydraulic pressure. The hydraulic fluid drives the fan motor's internal gear assembly, spinning the fan motor and the attached fan blade.

The Nelson hydraulic reservoir with internal filter system is located in the engine compartment. It is the reservoir for both the hydraulic fan drive system and power steering system. The hydraulic filter assembly is located inside the reservoir. The 25 micron\* filter system is designed to protect the precision tolerance hydraulic system components. Check the oil level in the reservoir when the oil is at operating temperature. This should be done every 6000 miles or three months. The oil dipstick/oil fill is located on top of the reservoir. The oil level should be kept between the full and add marks on the dipstick. Change the hydraulic oil filters every 15,500 miles or once a year. When performing fluid level checks inspect fittings and hoses for signs of leakage. Look underneath the motorhome for any signs of fluid leakage. Avoid untimely and costly failures by having leaks repaired. To change the filter system a five gallon drain bucket will be needed. Loosen the band clamp at the top of the reservoir and remove the lid. Place the drain bucket under the reservoir and loosen one of the bottom fittings to drain the reservoir. Drain only enough fluid from the reservoir to expose bottom filter, then tighten fitting. Remove the wing nut, filter spring and filter washer. Remove the three drop in filters and install the new ones. Install the filter washer and filter spring. Tighten the wing nut until wing nut reaches end of threaded rod. It is recommended to install new hydraulic fluid. Old fluid may contaminate the hydraulic system. Fill the reservoir with approximately three to four gallons to the full mark. Install top and band clamp. Run engine to purge any trapped air. Check fluid level after fifteen minutes of operation. Total system capacity is approximately 44 quarts. Monaco Coach filter number: 07010886. Nelson filter number: 84101B.

\*One micron is one millionth of one meter.

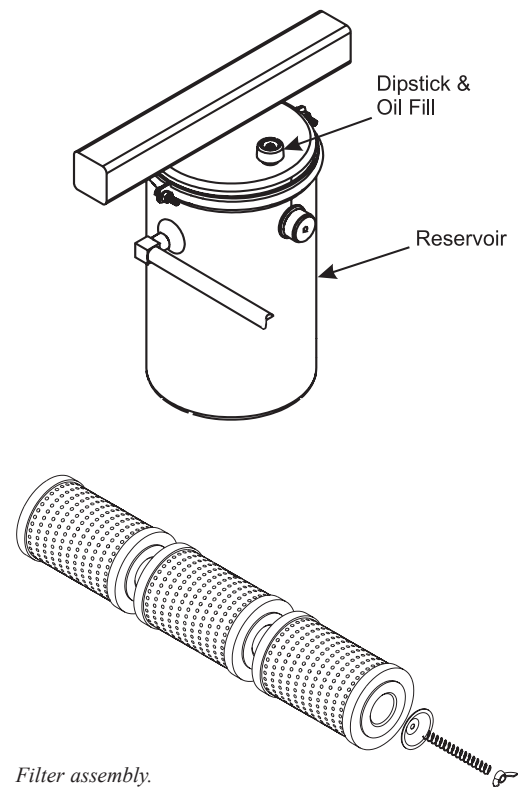
**Hydraulic Filter Reservoir**

*Filter assembly.*

## STEERING GEAR

The M-100 series Sheppard steering gear requires no maintenance. Power steering is provided by using hydraulic pressure to assist rotating the output shaft of the steering gear. Located at the end of the input shaft of the steering gear is poppet valve and worm drive. The poppet valve directs the hydraulic fluid pressure to a type of spool. There are worm drive threads in the center of the spool. When in the center position, pressurized hydraulic fluid bypasses the spool. When a turn is made the poppet valve shifts to one direction or the other, directing the hydraulic pressure to one side of the spool depending on turning direction. The hydraulic fluid is then cooled before returning to the reservoir. Inspect for signs of leakage when performing fluid level checks. Changing the hydraulic filter at regular intervals will help ensure trouble free operation.

## AIR FILTER MINDER

The air filter minder is a precision overflow restriction gauge designed to take the guesswork out of air cleaner replacement. The air filter minder is located in the engine rear compartment. Its operation is simple and virtually foolproof. As dirt captured by filter cartridge slowly builds up the system pressure drop increases and is indicated by the filter minder on an easy to read scale. The indicator locks up at the point of maximum restriction so readings can be taken with or without the engine running. When the desired change-out point is reached, the air filter should be replaced and the service indicator is easily reset by pushing the button at the bottom of the minder.

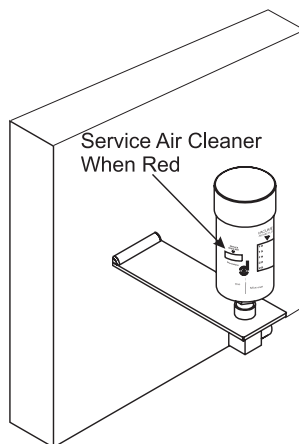

Located in the engine compartment.



## AIR FILTER Changing

To replace air cleaner remove three screws and cover from air cleaner body. Remove air cleaner cartridge and discard. Install new air cleaner cartridge and secure with cover and three screws.

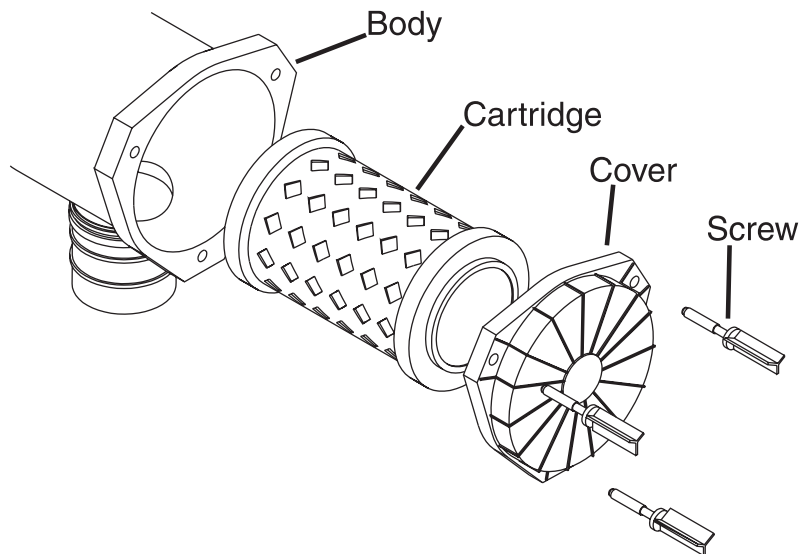

### Proper Drive Axle Lubricant Level

- Regular inspection of the drive axle lube levels is an essential maintenance procedure.
- The lubricant should be level with bottom of the hole.
- Important: The lube level close enough to the hole to be seen or touched is not sufficient. The lube must be level with the hole.
- Differential is filled with API GL-5 or MT-1 type gear lubricant, Pennzoil Gear Plus Super-EW 75w-90.

## DRIVE AXLE LUBRICANT



**NOTE: When checking the lube level also check the housing breathers. Clean the breathers if dirty or replace them if damaged.**

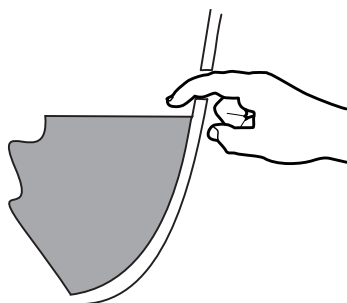

*Incorrect Oil Level.*

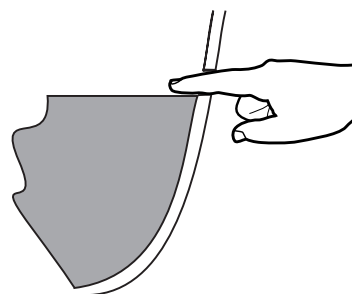

*Correct Oil Level*



## DRIVELINE

### Greasing the Driveline Universal Joint:

1. Check the driveline for looseness. If loose, service the driveline as necessary.
2. Apply the specified grease at the grease fitting on the universal joint. Apply grease until the new grease purges from all the seals.
3. If the new grease does not purge at the seals loosen the bearing cap bolts and regrease until all four caps purge. If the new grease still does not purge replace the universal joint.

### Greasing the Driveline Slip Yoke and Splines:

1. Check the driveline for looseness. If loose, service the driveline as necessary.
2. Cover the air hole so that grease can flow easily to the seal. Apply the specified grease at the grease fitting on the slip yoke. Apply grease until new grease purges from the air hole in the end of the slip yoke. Greasing Intervals-10,000 miles or annually.

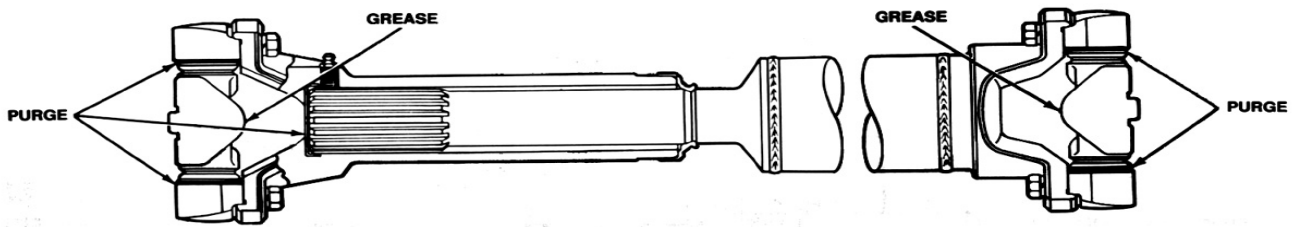

**LUBRICATION  
CHART-  
Front of Coach**

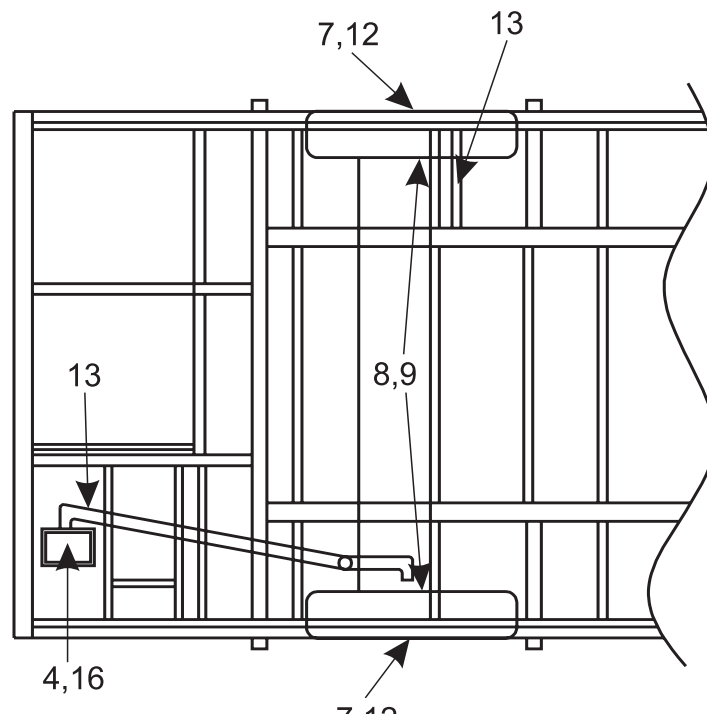

Service must be performed every twelve (12) months regardless of actual mileage, to protect seals, bearings and gaskets from drying out and failing. The motorhome must be started and driven for at least 20 miles bimonthly.

**Chart on Next Page**

1	Engine Oil	Keep To Full Mark	Check Daily	EO
2	Engine Oil Filter	Replace At Oil Change	Refer To Cummins	OP
3	Transmission	Refer To Service Manual	Check Daily	TF
4	Steering Shaft	3 Fittings	30,000 or Annually	CL-4
5	Drive Shaft U-Joints	2 Fittings	10,000 or Annually	CL-4
6	Drive Shaft Slip Joint	1 Fittings	10,000 or Annually	CL-4
7	Wheel Bearings	Repack	30,000 or Annually	HT
8	Brake Cam Shaft	One Fitting Each Wheel	30,000 or Annually	CL-4
9	Brake Adjuster	One Fitting Each Wheel	30,000 or Annually	CL-4
10	Battery Terminals	Apply Coating	10,000 or Annually	P
11	Rear Axle Differential	To Filler Plug	1000,000 Or 3 Years	MP
12	King Pins & Knuckles	2 Fitting Each End	30,000 or Annually	CL-4
13	Drag Link/Tie Rod	4 Fittings	30,000 or Annually	CL-4
14	Hydraulic Fluid Reservoir	Keep To Full	Check Daily	TF
15	Hydraulic Fluid Filter (if applicable)	Replace	15,000 or Annually	TF
16	Fuel Filter	Replace	At Oil Change	FF
17	Engine Coolant Capacity	Replace	Every 2 Years	AF

**Rear of Coach**

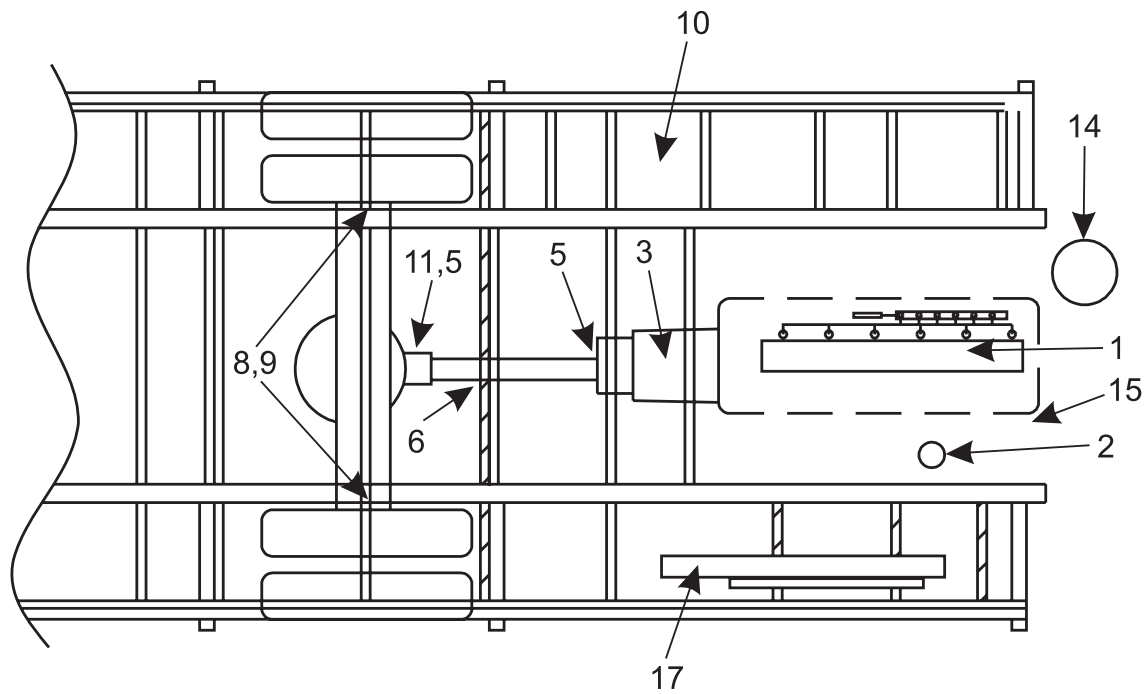

**Lubrication Code Chart**

<b>CI-4</b>
<b>EO</b>
<b>OP</b>
<b>MP</b>
<b>HT</b>
<b>CL</b>
<b>P</b>
<b>AF</b>
<b>TF</b>
<b>FF</b>

## PARTS - COMMON SOLENOIDS & SENDERS

### Rear Bag Dump Solenoid

- Used on hydraulic level and air level systems.
- Dumps air in air bags on hydraulic level units and is used to dump air from tag axle on air level units.
- Located in the engine compartment on the roadside, attached to frame below alternator.
- Type- Allen Air 36BXA-HB

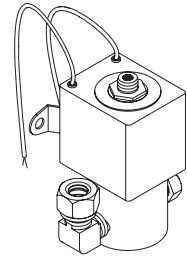

### Front Bag Dump or Tag Axle Solenoids

- Used on hydraulic level and tag axle units.
- Dumps air in front air bags and is used to raise or lower tag axle.
- Located in the generator compartment on the curbside.
- Type- MAC 225B-601BAAA

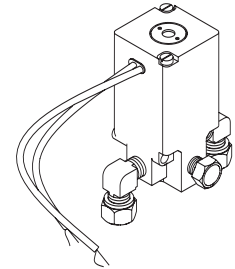

### Oil pressure Sending Unit

- One post is used for the oil pressure gauge and one post is for the warning light.
- Type- VDO 360 0238NDO 0-100 Ohm



### Water Temperature Sending Unit

- One post is used for the water temperature gauge and one post is used for the warning light.
- Type- VDO 323 0998

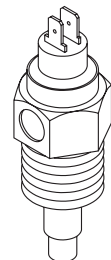

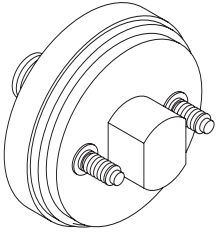

**Low Air Switch**

- 1/8-27 NPT thread.
- Normally closed until approximately 65 psi.
- Located behind dash panel.
- Type - Merritor Wabco 89404 16062

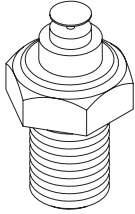

**Transmission Sending Unit**

- Located on the bottom of the tailshaft housing, between hoses.
- Type - VDO 323 0868

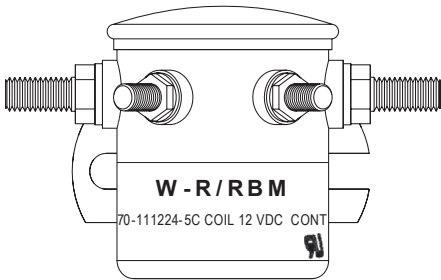

**House Disconnect and Starter Solenoid**

- Solenoid interfaces start signal to Cummins starter.
- Solenoid interrupts DC power to the house fuse panel.
- Four post solenoid with isolated coil.
- Located in high and low current plates.
- MP #8206

# TIRE - CHART

TIRE LOAD LIMITS (LBS) AT VARIOUS COLD INFLATION PRESSURES (PSI).												
TIRE SIZE	PSI	70	75	80	85	90	95	100	105	110	115	120
225/70R19.5	Single (S)	2895	3040	<b>3195(E)</b>	3315	3450	<b>3640(F)</b>	3715	3815	<b>3970(G)</b>		
	Dual (D)	2720	2860	<b>3000(E)</b>	3115	3245	<b>3415(F)</b>	3490	3615	<b>3750(G)</b>		
245/70R19.5	Single (S)	3640	3740	3890	<b>4080(F)</b>	4190	<b>4545(G)</b>	4620	<b>4805(H)</b>			
	Dual (D)	3415	3515	3655	<b>3875(F)</b>	3940	<b>4375(G)</b>	4500	<b>4625(H)</b>			
255/70R22.5	Single (S)	3815	4005	4190	4370	4550	4895	5065	<b>5205(G)</b>	<b>5510(H)</b>		
	Dual (D)	3585	3765	3970	4110	4275	4455	4610	<b>4765(G)</b>	<b>5070(H)</b>		
295/75R22.5	Single (S)	4725	4945	5155	5370	<b>5510(F)</b>	5980	<b>6175(G)</b>	6370	<b>6610(H)</b>		
	Dual (D)	4690	4885	<b>5070(F)</b>	5260	5440	5800	<b>6005(H)</b>				
11R22.5	Single (S)				4990	5200	5640	5840	<b>6175(G)</b>	6240	6430	<b>6610(F)</b>
	Dual (D)				<b>4760(F)</b>	4950	5300	5470	<b>5750(G)</b>	<b>5800(H)</b>		

TIRE SIZE	MAXIMUM LOAD AT INFLATION								LOAD RANGE	TIRE WEIGHT		SPEED RATING (MPH)
	Single (S)				Dual (D)					LB	[KG]	
	LBS	PSI	[KG	KPA]	LBS	PSI	[KG	KPA]				
245/70R19.5	4080	85	[1850	590]	3875	85	[1760	590]	F	69	[31]	75
255/70R22.5	5510	115	[2500	790]	5070	115	[2300	790]	H	86	[39]	75
11R22.5*	6610	120	[3000	830]	5800	110	[2630	760]	H	132	[69]	75
295/75R22.5	6610	110	[3000	850]	6005	110	[2725	800]	H	115	[52]	75

\*G159A - # Imported Tire. All data is tested under the condition of highway speed of 65 mph. 1. Letter in parenthesis denote load range for which **BOLD FACE** loads are maximum. 2. Always use Approved Tire and Rim Combinations for Diameters and Contours.

Monaco Coach Corporation is not the author of this chart and makes no representation or warranty concerning the accuracy of the information disclosed by the chart. Monaco is not responsible for the accuracy of the information disclosed or for any errors within the Tire Inflation Chart.

	MANUFACTURER	ISC 350
Coolant Filter	FLEETGUARD	WF 2071
Oil Filter	FLEETGUARD	LF 3000
Fuel Filter Pri	RAYCORE	S 3201 T
Fuel Filter Sec	FLEETGUARD	FS 1022
Aqua Hot Fuel	RAYCORE	R 12 T
Hydraulic Filter	PARKER	INHC5710
Alternator Belt	DAYCO	3911581
A/C Belt	DAYCO	17475
Air Filter	DONALDSON	EBA09-2037 (MP*-2284)

\*MP = Monaco Part #

## Chart for Filters and Belts



**NOTE: Filter and belt numbers were corrected at the time of printing. Verify the numbers at time of removal. Monaco Coach will not be responsible for incorrect filter or belt usage. Please refer to the engine manufacturer's operating instructions for specific maintenance information.**

## CHART - SPECIFICATIONS

<b>CHASSIS SPECIFICATIONS</b>					
	<b>36B</b>	<b>36D</b>	<b>38A</b>	<b>38D</b>	<b>38PBD</b>
<b>GVWR</b>	30,000 lbs.	30,000 lbs.	30,000 lbs.	30,000 lbs.	30,000 lbs.
<b>GCWR</b>	40,000 lbs.	40,000 lbs.	40,000 lbs.	40,000 lbs.	40,000 lbs.
<b>GAWR - (Front)</b>	11,000 lbs.	11,000 lbs.	11,000 lbs.	11,000 lbs.	11,000 lbs.
<b>GAWR - (Rear)</b>	19,000 lbs.	19,000 lbs.	19,000 lbs.	19,000 lbs.	19,000 lbs.
<b>Wheel Base</b>	216"	216"	242"	242"	256"
<b>Overall Width</b>	100.5"	100.5"	100.5"	100.5"	100.5"
<b>Overall Height</b>	11'11"	11'11"	11'11"	11'11"	11'11"
<b>Interior Height</b>	6'6"	6'6"	6'6"	6'6"	6'6"

<b>TANK CAPACITIES (Approximate Gallons)</b>					
	<b>36B</b>	<b>36D</b>	<b>38A</b>	<b>38D</b>	<b>38PBD</b>
<b>Water Heater</b>	10 gal.	10 gal.	10 gal.	10 gal.	10 gal.
<b>Grey Tank</b>	60 gal.	60 gal.	60 gal.	60 gal.	60 gal.
<b>Black Tank</b>	40 gal.	40 gal.	40 gal.	40 gal.	40 gal.
<b>Fresh Tank</b>	100 gal.	100 gal.	100 gal.	100 gal.	100 gal.
<b>Fuel Tank</b>	100 gal.	100 gal.	100 gal.	100 gal.	100 gal.
<b>LP Tank</b>	38 gal.	38 gal.	38 gal.	38 gal.	38 gal.
<i>*Actual filled LP capacity is 80% of listing due to safety shut off required on tank.</i>					









<b>A</b>			
ABS System.....	235	Customer Relations.....	8
Air Conditioner.....	102		
Air Coupler - Universal.....	230	<b>D</b>	
Air Filter Charging.....	265	Dash .....	200
Air Filter Minder.....	264	Diagnostic Plug Locations.....	214
Air Governor.....	228	Dinette Bed Conversion.....	133
Air Storage Tanks.....	229	Distribution Panel - House 110 Volt .....	180
Air Supply System.....	228	Distribution Panel - House 12 Volt.....	184
Air System - Charging (External).....	230	Draining The Waste Holding Tanks.....	146
Alternator.....	221	Drive Axle Lubricant.....	265
Alignment Specifications.....	238	Driveline.....	266
Awnings.....	127	Driving - Parking.....	34
Awning Automatic (Optional).....	131	Driving Safety.....	24
		Dry Camping Tips.....	41
<b>B</b>			
Battery - Chassis.....	198	<b>E</b>	
Battery Disconnect - Chassis.....	197	Egress Exit Window.....	49
Battery Disconnect - House.....	166	Energy Management System 50 Amp.....	181
Battery - How It Works.....	185	Emergency Procedures - Jump Starting.....	159,252
Brake Adjustment/Slack Adjuster.....	234	Emergency Procedures .....	38
Braking - Engine.....	251	Engine - General Information.....	245
Brake - Exhaust.....	252	Engine Shutdown.....	249
Brake - Park & Emergency Systems.....	234	Engine Shutdown - Extended.....	249
Brake Systems - Air Brakes.....	233	Entertainment Center - Home.....	123
Brake Systems - Back Up.....	237	Entry Door.....	117
Bulb Usage - Exterior.....	224	Entry Step.....	115
Bulb Usage - Interior.....	193	Exterior Care.....	69
<b>C</b>		<b>F, G</b>	
Carbon Monoxide Detector.....	47	Fire Extinguisher.....	49
Chart - Filters & Belts.....	271	Fuel Sending Unit.....	259
Chart - Specifications.....	272	Fuel System.....	251
Chart - Tire.....	271	Fuel Tank.....	259
Chassis Log.....	273	Fuel/Water Separator (ISC Engine).....	259
Checklist - Items to Carry.....	29	Furnace.....	103
Checklist - LP-Gas Emergency Procedures..	158	Fuses & Circuits - Chassis.....	219
Checklist - Opening the Motorhome.....	26	Generator 120 AC.....	168
Checklist - Ready to Leave.....	29	GFCI Breakers & Outlets.....	43
Checklist - Set-up Procedures.....	41	Glossary of Terms.....	279
Checklist - Winter Storage.....	30		
Citizen Band Radio.....	127		
Cold Weather Use.....	147		
Cooktop .....	100		
Coolant.....	249		

**H, I**

Hydraulic Systems.....	260
Index.....	276
Inflation & Weighing.....	55
Interior Bulb Chart.....	193
Interior Care.....	73
Inverter/Converter.....	171
ISC Engine.....	245

**J, K, L**

Leveling System - Hydraulic Leveling.....	241
Limited Warranty.....	14
LP-Gas Consumption.....	161
LP-Gas Detector.....	45,156
LP-Gas Distribution Lines.....	161
LP-Gas Regulator.....	160
LP-Gas System.....	155
LP-Gas Tank.....	159
Lubrication Chart.....	267

**M, N, O**

Manual Override.....	121
Microwave Oven.....	94
Monitor Panel.....	137,158
Oil Recommendations.....	246
Owner's Record - Insurance.....	12
Owner's Record - Personal Property.....	12
Owner's Record - Serial Numbers.....	13

**P, Q, R**

Parts - Common Solenoids & Senders.....	269
RC-9 Remote Control.....	178
Refrigerator.....	90, 115
Reporting Safety Defects.....	11
Ride Height Valves.....	231

**S**

Service Suggestions.....	10
Screen Door.....	218
Shifter Panel.....	214
Shock Absorbers.....	240
Shore Power Hook-Up.....	167
Slide-Out Room.....	119
Smoke Detector.....	44
Starting Procedure (ISC Normal).....	246
Starting Procedure -Cold Weather.....	246
Steering Column .....	218
Steering Gear.....	264
Stepwell Cover (Front Door Model).....	117
Storage - Long Term.....	31
Storage Under Bed .....	134
Super Slide (Optional).....	31
Suspension - Air Ride Bags.....	232
Sunvisor (Optional).....	133

**T, U**

Tank Capacities.....	143,272
Taking Delivery.....	9
Tires & Wheels.....	50
To Extend Fixed Dinette.....	134
Toilet.....	144
Towing Procedures.....	39
Transmission.....	253
Transmission Lubricating Fluid.....	257

**V, W, X, Y, Z**

Video Selector Box..... 125  
Views - Curbside & Roadside..... 65  
Views - Front & Rear..... 64  
Vendor List..... 18  
Warranty Information File..... 10  
Washer - Dryer (Optional)..... 109  
Washer - Dryer Prepared..... 108  
Water - City Water Hook-Up..... 139  
Water Filters..... 141  
Water Heater..... 106  
Water Pump..... 139  
Water Systems..... 142  
Water System - Disinfecting..... 142  
Water System - Waste Drain & Sewage..... 143  
Water Tank Fill & Gravity..... 138  
Weighing The Motorhome..... 59  
Weight Terms..... 57  
Winterizing..... 149

**NOTES**

## Glossary of Terms

**AC Electricity** - Alternating current also known as household power.

**Air Compressor** - A device that pumps air to and builds air pressure in an air system.

**Air Dryer** - A device that cools, filters, and dries the air delivered by an air compressor.

**Air Governor** - A device that controls the operation of the air compressor by constantly monitoring air pressure in the supply tank of the air system. The air governor initiates the unload cycle when the cut-out pressure is reached. The air governor also controls the air dryer by sending an air signal (at the beginning of the compressor cycle) to the control port of the air dryer, initiating the purge cycle. When this air signal is removed by the governor (at the beginning of the compressor load cycle) the purge valve closes and the drying cycle begins.

**Ampere (Amp)** - The unit of measure of electron flow rate of current through a circuit.

**Ampere-hour (Amp-hr. AH)** - A unit of measure for a battery electrical storage capacity, obtained by multiplying the current in amperes by the time in hours of discharge (Example; a battery which delivers 5 amperes for 20 hours, delivers 5 amperes times 20 hours, or 100 Amp-Hr. of capacity.)

**Black Water** - Term associated with the sewage holding tank. The toilet drains directly into this tank.

**Chassis Battery** - Powers chassis 12V accessories and starts engine.

**Circuit** - An electric circuit is the path of an electric current. A closed circuit has a complete path. An open circuit has a broken or disconnected path.

**City Water** - A term associated with the water supply that you hook-up to when you are at camp-grounds. It is called city water because you pull water from a central source (like in a city) and not the fresh water tank.

**Compressor Load Cycle** - The time during which the air compressor is building air pressure in an air system.

**Compressor Unload Cycle** - The time during which the air compressor is idling and is not building air pressure in an air system.

**Curbside** - This refers to the side of the motorhome which faces the curb when it is parked. Often called the door side.

**Current (Alternating) (AC)** - A current that varies periodically in magnitude and direction. A battery does not deliver alternating current. Also referred to as shore power, utility power, inverter power, generator power, etc.

**Current** - The rate of flow of electricity or the movement rate of electrons along a conductor. It is comparable to the flow of a stream of water. The unit of measure for current is the ampere.

**Cut-In Pressure** - The pressure level in the air system supply tank which triggers the compressor load cycles.

**Cut-Out Pressure** - The pressure level in the air system supply tank which triggers the compressor unload cycle.

**Cycle** - In a battery, one discharge plus one recharge equals one cycle.

**DC Electricity** - Direct current also known as battery power.

**Decicant** - A granular substance that has a high affinity for water and is used to retain moisture from the air stream flowing through the air dryer cartridge.

**Direct Current (DC)** - Power that is stored in a battery bank or supplied by photovoltaics, alternator, chargers and DC generators.

**Drain Trap** - This is a curve that is in all drains. Water is trapped in the curve and this creates a barrier so tank odors cannot escape through the drain.

**Dry Camping** - Camping in the motorhome when there is no city water hook-up or shore power. In other words, using only the water and power that is in the motorhome and not anything from another source.

**Drying Cycle** - The time during which the air dryer cools, filters and removes moisture from the air delivered by the air compressor. The drying cycle begins and ends the same as the compressor load cycle.

**Dump Station** - Sites where you can drain your waste (gray) and sewage (black) tanks. In most states it is illegal to drain your tanks anywhere except at dump stations.

**Dump Valve** - Another name for the T-handle valve used to drain the sewage (black) and waste (gray tanks).

**Egress Window** - The formal name for the emergency window located in the rear of the motorhome. Egress windows can be easily identified by their red handles.

**Full Hook-Up Site** - A campground that has city water, shore power and sewer hook-ups or connections available.

**Gray Water** - Term associated with the waste water holding tank. Water from the sink drains, the shower and the washer/dryer (if equipped) go into this tank.

**House Battery** - Powers 12V lights and accessories inside motorhome.

**LED** - (Light Emitting Diode) Indicator light.



**Low Point** - The lowest point in the plumbing. Drains are placed here so that water will drain out of the lower end of the motorhome. These drains must be closed when you fill the water tank.

**OHM** - A unit for measuring electrical resistances.

**Ohm's Law** - Express the relationship between volt (E), amperes (I) in an electrical circuit with resistances (R). It can be expressed as follows:  $E=IR$ . If any two of the three values are known, the third value can be calculated by using the above formula.

**Purge** - The initial blast of air (decompression) from the air dryer purge valve at the beginning of the air compressor.

**Purge Cycle** - The time during which the air dryer is undergoing purge and regeneration. This cycle starts at the beginning of the compressor unload cycle and normally ends well before the beginning of the compressor load cycle.

**Regeneration** - The mild backflow of air through the air dryer and out the purge valve that begins immediately after the purge and lasts normally 10 to 15 seconds. This backflow of air, from the air system and through the air dryer, removes moisture from the desiccant cartridge and prepares the air dryer for the next compressor load cycle.

**Road Side** - This refers to the side of the motorhome which faces the road when it is parked. Often called the off-door side.

**Shore Line** - This is the electrical cord which runs from the motorhome to the camp ground 120 Volt electrical supply.

**Shore Line Plug** - This is the 120 Volt outlet that you can plug your motorhome into a campground.

**Stinger** - An arm attachment on a tow truck that is used to lift motorhome slightly so that it can be towed.

**Volt** - The unit of measure for electric potential.

**Watt** - The unit for measuring electrical power, i.e., the rate of doing work, in moving electrons by or against an electric potential.

**Wet Cell Battery** - A type of battery that uses liquid as an electrolyte. This type of battery requires periodic maintenance such as cleaning the connections and checking the electrolyte level.

