

# iAuCS® Automatic Cleaning System

## Installation, Operation and Maintenance Manual



 **Caution**

Read this instruction before operating this equipment.

**Original Document**

Part Number 000009036 Rev03 6/18



# Safety Notices

## Safety Notices

### Read these precautions to prevent personal injury:

- Read this manual thoroughly before operating, installing or performing maintenance on the equipment. Failure to follow instructions in this manual can cause property damage, injury or death.
- Routine adjustments and maintenance procedures outlined in this manual are not covered by the warranty.
- Proper installation, care and maintenance are essential for maximum performance and trouble-free operation of your equipment. Visit our website [www.manitowocice.com](http://www.manitowocice.com) for manual updates, translations, or contact information for service agents in your area.
- This equipment contains high voltage electricity and refrigerant charge. Installation and repairs are to be performed by properly trained technicians aware of the dangers of dealing with high voltage electricity and refrigerant under pressure. The technician must also be certified in proper refrigerant handling and servicing procedures. All lockout and tag out procedures must be followed when working on this equipment.
- This equipment is intended for indoor use only. Do not install or operate this equipment in outdoor areas.

## DEFINITIONS

### DANGER

Indicates a hazardous situation that, if not avoided, will result in death or serious injury. This applies to the most extreme situations.

### Warning

Indicates a hazardous situation that, if not avoided, could result in death or serious injury.

### Caution

Indicates a hazardous situation that, if not avoided, could result in minor or moderate injury.

### Notice

Indicates information considered important, but not hazard-related (e.g. messages relating to property damage).

NOTE: Indicates useful, extra information about the procedure you are performing.

### Warning

#### Follow these electrical requirements during installation of this equipment.

- All field wiring must conform to all applicable codes of the authority having jurisdiction. It is the responsibility of the end user to provide the disconnect means to satisfy local codes. Refer to rating plate for proper voltage.
- This appliance must be grounded.
- This equipment must be positioned so that the plug is accessible unless other means for disconnection from the power supply (e.g., circuit breaker or disconnect switch) is provided.
- Check all wiring connections, including factory terminals, before operation. Connections can become loose during shipment and installation.

### Warning

#### Follow these precautions to prevent personal injury during installation of this equipment:

- Installation must comply with all applicable equipment fire and health codes with the authority having jurisdiction.
- To avoid instability the installation area must be capable of supporting the combined weight of the equipment and product. Additionally the equipment must be level side to side and front to back.
- Ice machines require a deflector when installed on an ice storage bin. Prior to using a non-OEM ice storage system with this ice machine, contact the bin manufacturer to assure their ice deflector is compatible.
- Do not damage the refrigeration circuit when installing, maintaining or servicing the unit.
- Connect to a potable water supply only.
- Some 50 Hz models may contain up to 150 grams of R290 (propane) refrigerant. R290 (propane) is flammable in concentrations of air between approximately 2.1% and 9.5% by volume (LEL lower explosion limit and UEL upper explosion limit). An ignition source at a temperature higher than 470°C is needed for a combustion to occur. Refer to nameplate to identify the type of refrigerant in your equipment. Only trained and qualified personnel aware of the dangers are allowed to work on the equipment.

**⚠ Warning**

**Follow these precautions to prevent personal injury while operating or maintaining this equipment:**

- Read this manual thoroughly before operating, installing or performing maintenance on the equipment. Failure to follow instructions in this manual can cause property damage, injury or death.
- Crush/Pinch Hazard. Keep hands clear of moving components. Components can move without warning unless power is disconnected and all potential energy is removed.
- Moisture collecting on the floor will create a slippery surface. Clean up any water on the floor immediately to prevent a slip hazard.
- Objects placed or dropped in the bin can affect human health and safety. Locate and remove any objects immediately.
- Never use sharp objects or tools to remove ice or frost. Do not use mechanical devices or other means to accelerate the defrosting process.
- When using cleaning fluids or chemicals, rubber gloves and eye protection (and/or face shield) must be worn.

**⚠ DANGER**

Do not operate equipment that has been misused, abused, neglected, damaged, or altered/modified from that of original manufactured specifications. This appliance is not intended for use by persons (including children) with reduced physical, sensory or mental capabilities, or lack of experience and knowledge, unless they have been given supervision concerning use of the appliance by a person responsible for their safety. Do not allow children to play with, clean or maintain this appliance without proper supervision.

**⚠ DANGER**

**Follow these precautions to prevent personal injury during use and maintenance of this equipment:**

- It is the responsibility of the equipment owner to perform a Personal Protective Equipment Hazard Assessment to ensure adequate protection during maintenance procedures.
- Do Not Store Or Use Gasoline Or Other Flammable Vapors Or Liquids In The Vicinity Of This Or Any Other Appliance. Never use flammable oil soaked cloths or combustible cleaning solutions for cleaning.
- All covers and access panels must be in place and properly secured when operating this equipment.
- Risk of fire/shock. All minimum clearances must be maintained. Do not obstruct vents or openings.
- Failure to disconnect power at the main power supply disconnect could result in serious injury or death. The power switch DOES NOT disconnect all incoming power.
- All utility connections and fixtures must be maintained in accordance with the authority having jurisdiction.
- Turn off and lockout all utilities (gas, electric, water) according to approved practices during maintenance or servicing.
- Units with two power cords must be plugged into individual branch circuits. During movement, cleaning or repair it is necessary to unplug both power cords.
- Never use a high-pressure water jet for cleaning on the interior or exterior of this unit. Do not use power cleaning equipment, steel wool, scrapers or wire brushes on stainless steel or painted surfaces.
- Two or more people are required to move this equipment to prevent tipping.
- Locking the front casters after moving is the owner's and operator's responsibility. When casters are installed, the mass of this unit will allow it to move uncontrolled on an inclined surface. These units must be tethered/secured to comply with all applicable codes.
- The on-site supervisor is responsible for ensuring that operators are made aware of the inherent dangers of operating this equipment.
- Do not operate any appliance with a damaged cord or plug. All repairs must be performed by a qualified service company.

# Table of Contents

---

## Safety Notices

<b>Safety Notices</b> .....	<b>3</b>
Definitions .....	3

## Section 1

### General Information

<b>Compatible Ice Machine Models</b> .....	<b>7</b>
Model Compatibility.....	7
<b>Indigo® NXT</b> .....	<b>7</b>
<b>iAuCS® Location</b> .....	<b>7</b>
<b>Warranty Information</b> .....	<b>7</b>

## Section 2

### Installation

<b>General</b> .....	<b>9</b>
<b>Electrical Service</b> .....	<b>9</b>
General.....	9
<b>iAuCS® Installation</b> .....	<b>9</b>
Location/Mounting .....	9
Height Requirement.....	10
Distance Requirement.....	10
Mounting.....	10
Connection to Ice Machine .....	11

## Section 3

### Operation

<b>Determine Type of Solution Needed</b> .....	<b>15</b>
Manitowoc Ice Machine Cleaner .....	15
Manitowoc Ice Machine Sanitizer .....	15
<b>Installing/Replacing Cleaner or Sanitizer Bottles</b> .....	<b>15</b>
<b>Indigo® NXT Model Procedures</b> .....	<b>16</b>
Indigo® NXT Automatic Operation .....	16
Indigo® NXT Setting Frequency of Cleaning .....	16
Indigo® NXT Hose Priming.....	16
Indigo® NXT Manual Start Operation .....	17
Indigo® NXT Changing the Solution Type .....	17
<b>Indigo® Model Procedures</b> .....	<b>18</b>
Indigo® Model Automatic Operation .....	18
Setting Frequency of Cleaning Indigo® Models.....	18
Indigo® Model Hose Priming.....	18
Indigo® Model Changing the Solution Type .....	19
Indigo® Model Manual Start Operation .....	19
Changing Switch Position During Operation .....	19
<b>Removal from Service/Winterization</b> .....	<b>20</b>

THIS PAGE INTENTIONALLY LEFT BLANK

# Section 1

## General Information

### Compatible Ice Machine Models

The iAuCS® accessory can be used on Manitowoc Indigo® Series ice machines.

NOTE: Automatic Cleaning Systems are not compatible with S3000 Series, Flake/Nugget, NEO or SM50 model ice machines.

### MODEL COMPATIBILITY

#### Indigo®

Self-Contained Air-Cooled	Self-Contained Water-Cooled	Remote	QuietQube Models
ID0302A	ID0303W	----	----
IY0304A	IY0305W	----	----
ID0322A	ID0323W	----	----
IY0324A	IY0325W	----	----
ID0452A	ID0453W	----	----
IY0454A	IY0455W	----	----
IR0500A	IR0501W	IR0590N	----
ID0502A	ID0503W	ID0592N	----
IY0504A	IY0505W	IY0594N	----
IR0520A	IR0421W	----	----
ID0522A	ID0423W	----	----
IY0524A	IY0425W	----	----
ID0602A	ID0603W	ID0692N	ID0682C
IY0604A	IY0605W	IY0694N	IY0684C
----	----	----	IB0694YC
----	----	----	IB0692DC
IR0850A	IR0851W	IR0890N	ID0872C
ID0852A	ID0853W	ID0892N	IY0874C
IY0854A	IY0855W	IY0894N	IB0894YC
----	----	----	IB0892DC
IR0906A	IR0906W	IR0996N	ID0976C
ID0906A	ID0906W ID0906WM	ID0996N	IY0976C
IY0906A	IY0906W IY0906WM	IY0996N	----
ID1002A	ID1003W	ID1092N	ID1072C
IY1004A	IY1005W	IY1094N	IY1074C
----	ID1003WM	----	IB1094YC
----	----	----	IB1092DC
ID1202A	ID1203W	----	ID1272C
IY1204A	IY1205W	----	IY1274C
ID1402A	ID1403W	ID1492N	ID1472C
IY1404A	IY1405W	IY1494N	IY1474C
----	ID1403WM	----	----
IR1800A	IR1801W	IR1890N	ID1872C
ID1802A	ID1803W	ID1892N	IY1874C
IY1804A	IY1805W	IY1894N	----
----	----	----	ID2172C
----	----	----	IY2174C

### Indigo® NXT

Self-Contained Air-Cooled	Self-Contained Water-Cooled	Remote	QuietQube Models
IDF0300A	IDF0300W	----	----
IYF0300A	IYF0300W	----	----
IDT0420A	IDT0420W	----	----
IYT0420A	IYT0420W	----	----
IDT0450A	IDT0450W	----	----
IYT0450A	IYT0450W	----	----
IDT0500A	IDT0500W	IDT0500N	----
IYT0500A	IYT0500W	IYT0500N	----
IRT0500A	IRT0500W	----	----
IDF0600A	IDF0600W	IDF0600N	IYF0600C
IYF0600A	IYF0600W	IYF0600N	----
IDT0620A	IDT0620W	----	IBF0620C
IYT0620A	IYT0620W	----	----
IRT0620A	----	----	----
IDP0620A	----	----	----
IDF0900A	IDF0900W	IDF0900N	IBF0820C
IYF0900A	IYF0900W	IYF0900N	IYF0900C
IRF0900A	----	----	IBT1020C
IDT1200A	IDT1200W	IDT1200N	IDT1200C
IYT1200A	IYT1200W	IYT1200N	IYT1200C
IDT1500A	IDT1500W	IDT1500N	IDF1400C
IYT1500A	IYT1500W	IYT1500N	IYF1400C
IDT1900A	IDT1900W	IDT1900N	IDF1800C
IYT1900A	IYT1900W	IYT1900N	IYF1800C
IRT1900A	----	IRT1900N	----
----	----	----	IDF2100C
----	----	----	IYF2100C

### iAuCS® Location

The iAuCS® is mounted on the wall near the ice machine, or on the bin with the included bracket and hardware.

The iAuCS® must be installed by a trained and qualified technician.

### Warranty Information

Visit [www.manitowocice.com](http://www.manitowocice.com) for:

- Warranty Verification
- Warranty Registration
- View and download a copy of your warranty

THIS PAGE INTENTIONALLY LEFT BLANK

# Section 2 Installation

## General

These instructions are provided to assist the qualified installer. Check your local Yellow Pages for the name of the nearest distributor, or contact Manitowoc Ice for information regarding start-up services.

Please contact your local Manitowoc Distributor or contact Manitowoc Ice for assistance if you encounter a problem that is not covered by this manual.

### Notice

Failure to follow these installation guidelines may affect warranty coverage. Improper installation will affect dispensing rate. Install only within the parameters outlined in this installation manual.

## Electrical Service

### GENERAL

#### ⚠ Warning

A trained and qualified technician must install the iAuCS®.

Voltage Phase Cycle	Amperage
115/1/60	0.3
208-230/1/60	0.1

Line voltage is obtained from the ice machine. Refer to the Model/Serial plate on the ice machine and iAuCS® to verify both voltages are the same.

## iAuCS® Installation

### LOCATION/MOUNTING

#### ⚠ Warning

All wiring must conform to local, state and national codes.

#### ⚠ Warning

The ice machine and iAuCS® must be grounded in accordance with national and local electrical codes.

#### Important

Observe correct polarity of incoming line voltage.

The location selected must meet the following criteria. If any of these criteria are not met, select another location.

- The location must be free of airborne and other contaminants.
- The air temperature must be at least 40°F (4°C), but must not exceed 110°F (43°C).
- The location must not be near heat-generating equipment or in direct sunlight.

#### Notice

The iAuCS® accessory must be protected if it will be subjected to temperatures below 32°F (0°C). Failure caused by exposure to freezing temperatures is not covered by the warranty. See "Removal from Service/ Winterization" on page 20.

**HEIGHT REQUIREMENT**

Either the base or the top of the iAuCS® accessory must be within 2" (5 cm) of the base of the ice machine. Do not mount the iAuCS® unit too high or too low.

**Notice**

The cleaner or sanitizer may siphon (or dispense improperly) into the ice machine water trough if the iAuCS® unit is mounted too high or too low.

**DISTANCE REQUIREMENT**

The iAuCS® unit must be mounted within 9 feet (2.7 m) of the ice machine to accommodate the low voltage communication wire and tubing. The tubing may be shortened to accommodate a run of less than 9 feet (2.7 m).

**Notice**

Do not extend the length of the 9-foot (2.7 m) low voltage communication wire or tubing. The correct amount of solution will not dispense.

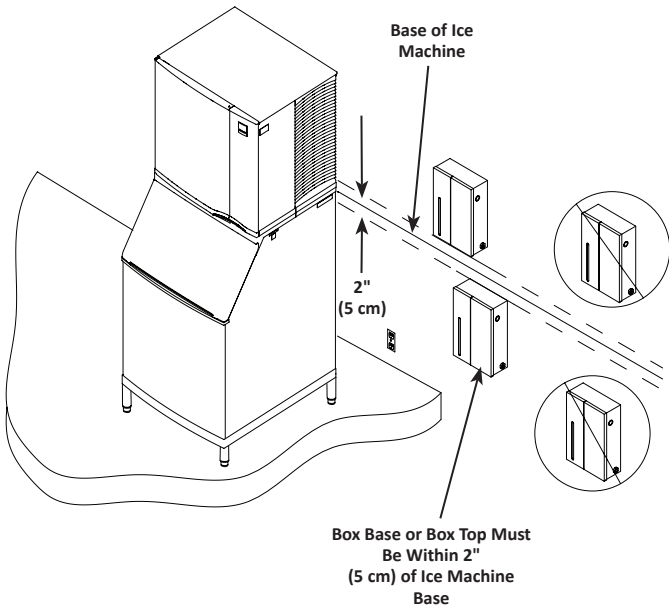

**MOUNTING**

**Parts**

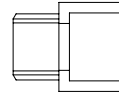

1/2" PVC Conduit Fitting

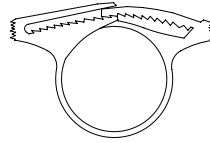

Hose Clamps

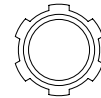

Locknut



Bumper

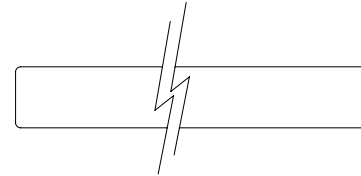

Foam Tape

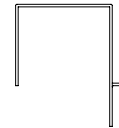

Bracket

**Notice**

The iAuCS® unit may be mounted to the bin or dispenser only when permitted by local electrical codes.

**Mounting to Bin or Dispenser**

NOTE: The ice machine's serviceability may be reduced when the iAuCS® unit is mounted to the bin or dispenser. Wall mounting is recommended.

1. Set the mounting bracket over the bin top rail at desired location.
2. Remove the backing from the foam adhesive tape. Apply tape to mounting bracket, and along the entire bin rail.
3. Align the iAuCS® key slots with the mounting bracket tabs. Verify the tabs are at the top of the key slots and that the iAuCS® unit is level.

- Remove the backing from the adhesive bumpers. Attach bumpers to the mounting bracket directly above the iAuCS® control box. This eliminates upward movement and stops the tabs from disengaging the key slots.

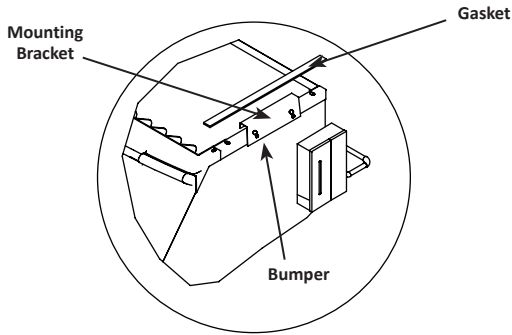

**Mounting to Ice Machine**

**Mounting to Wall**

The iAuCS® is mounted to the wall using the two key slots in the back wall of the accessory. Screw fasteners (not supplied) must hold the entire weight of the iAuCS® (approximately 10 lbs. [4.5 kg]).

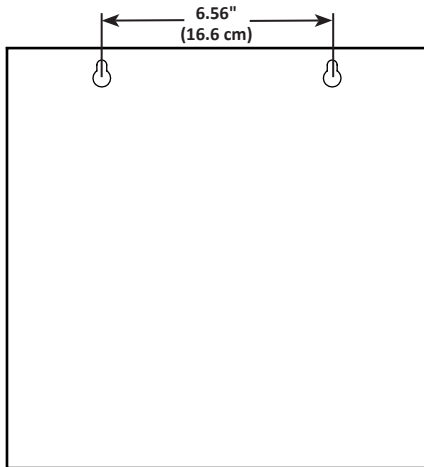

**Key Slot Dimensions**

**CONNECTION TO ICE MACHINE**

**Electrical Connections**

- Check electrical code for your area.
  - When local code allows, the included wire and strain relief can be used for line voltage wiring. Remove knockout from ice machine and install strain relief and wire.
  - When conduit is required, remove strain relief and ice machine electrical knockout. Install conduit as required by your electrical code.

**⚠ Warning**

Disconnect the electrical power supply to the ice machine at the electrical disconnect before proceeding.

- Connections on ice machines vary. Refer to the diagram for the ice machine you are working on.
- Remove the front, top, and right side panels from the ice machine.
  - Route line voltage wires through control box line voltage Heyco fitting. Connect line voltage wires to incoming power supply of contactor and ground screw.

NOTE: On QuietQube Ice Machines the power connection is made at the incoming power supply (L1 and L2). Cut-off yellow terminal (L2) and purple terminal (L1) on iAuCS® harness. Strip insulation back 1/2" and connect.

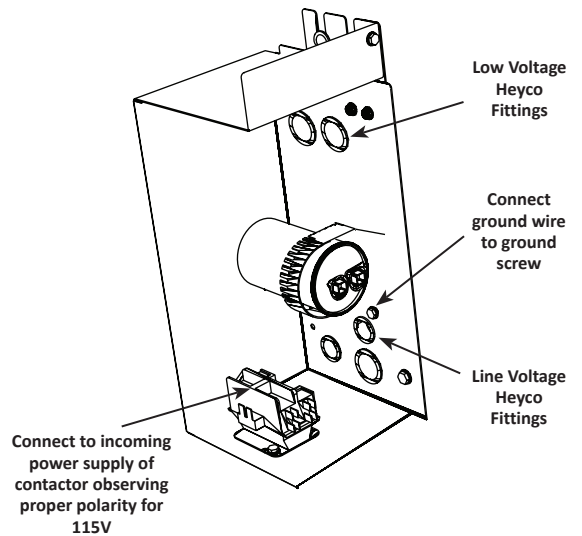

**Communication Wire and Vinyl Tubing**

The communication wire and vinyl tubing must be installed in conduit to protect them from damage.

1. Remove the 7/8" knockout hole plug located on the back of the ice machine.
2. Install conduit from the iAuCS® unit to the ice machine. A pulling elbow is recommended for easier routing of the vinyl tubing and modular wire.
3. Route low voltage communication wire and vinyl tubing together through the conduit.
4. Route modular wire through control box low voltage Heyco fitting. Do not route with line voltage wiring, as erratic operation could result. Connect modular wire to control board.
5. Connect the communication wire to the iAuCS® control board.

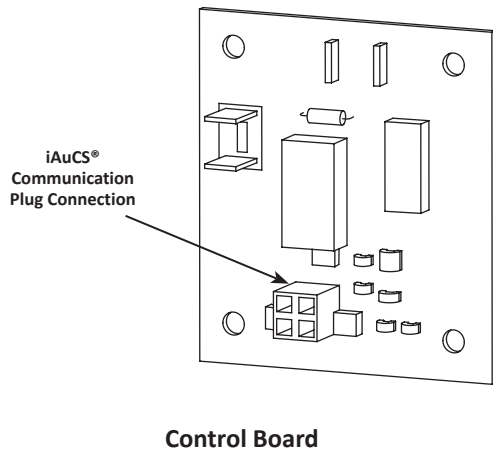

**Vinyl Tubing Connection**

1. Remove the water trough.
  - A. Depress tabs on right and left side of the water trough.
  - B. Allow front of water trough to drop as you pull forward to disengage the rear pins.
2. Locate the water inlet tube on the right hand side (see below) of the ice machine base.
  - After serial number 1101246915 - Use a screwdriver to remove membrane.
  - Before serial number 1101246915 - Press up on the plug until it is out.

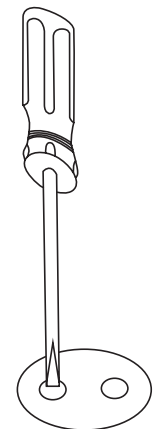
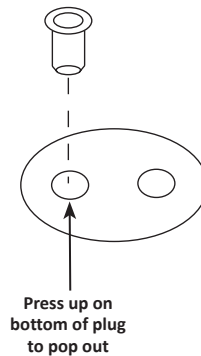
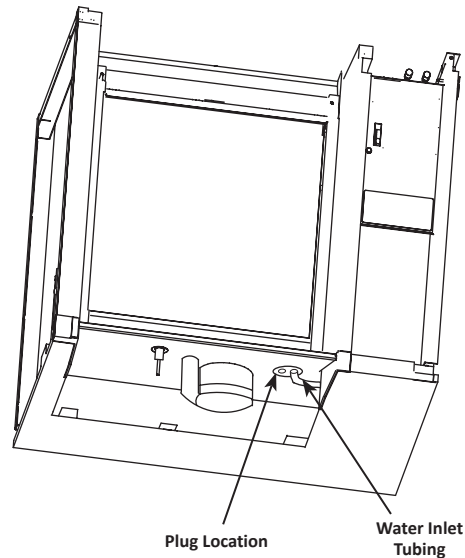

After Serial Number 1101246915 use screwdriver to remove membrane

3. Locate and remove either the membrane material or the plug from the ice machine.
4. Apply food grade silicone and install Y connector through the hole in the ice machine base. Connect the clear vinyl tubing to one side of the Y branch. The other side is for the plug removed in step 3 or the plug provided with the iAuCS®.

5. Determine the amount of tubing required in the iAuCS® control box and cut off the excess tubing.
6. Slide the tubing on the iAuCS® pump.

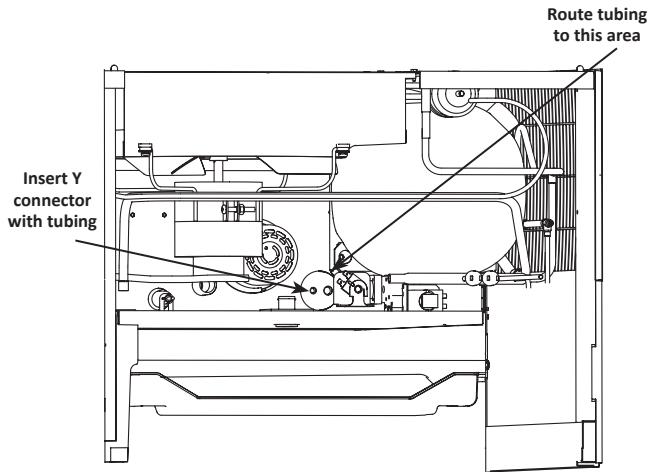

Top View

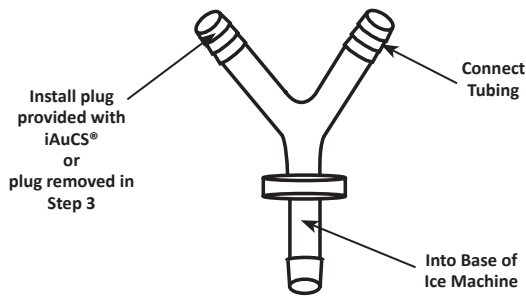

Y-Connector

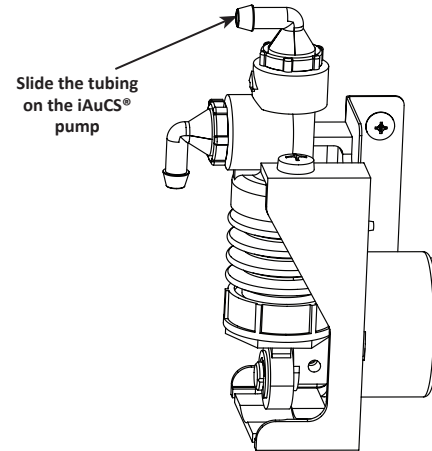

THIS PAGE INTENTIONALLY LEFT BLANK

## Section 3 Operation

### Determine Type of Solution Needed

**⚠ Caution**

Use only Manitowoc approved Ice Machine Cleaner & Sanitizer. It is a violation of Federal law to use these solutions in a manner inconsistent with their labeling. Read and understand all labels on the bottles before use.

The iAuCS® accessory will dispense Cleaner OR Sanitizer. It cannot dispense both at the same time.

#### MANITOWOC ICE MACHINE CLEANER

##### Part Number 9405463

Ice Machine Cleaner is used to control buildup and to remove lime scale or other mineral deposits. It will not “sanitize” the ice machine.

It is recommended for use in places that have lime scale or other mineral deposits, but no problems with slime.

Model	Amount of Cleaner Dispensed
22" or 30" Ice Machine	3 oz (88 ml)
48" Ice Machine	6 oz (177 ml)

#### MANITOWOC ICE MACHINE SANITIZER

##### Part Number 9405653

Ice Machine Sanitizer is used for sanitizing and controlling algae buildup (slime) and other bacterial growth. The ice machine (and bin or dispenser) must be sanitized on a regular schedule, following Manitowoc recommendations and local regulations.

It is recommended for use in places such as pizzerias, bars, bakeries, etc., that have airborne bacteria (yeast). Sanitizing is also recommended in places that do not have lime scale (or other mineral deposit problems).

Model	Amount of Sanitizer Dispensed
22" or 30" Ice Machine	3 oz (88 ml)
48" Ice Machine	6 oz (176 ml)

**Important**

Using the iAuCS® accessory is supplemental to regular cleaning and sanitizing. The iAuCS® accessory will clean surfaces that come in contact with the water distribution system. Periodic maintenance must be performed every six months that includes sanitizing the bin (or dispenser) and adjacent surface areas, which cannot be contacted by the water distribution system. Refer to the ice machine installation operation and maintenance manual for cleaning/sanitizing procedures.

### Installing/Replacing Cleaner or Sanitizer Bottles

**⚠ Caution**

Do not mix Cleaner and Sanitizer solutions together. It is a violation of Federal law to use these solutions in a manner inconsistent with their labeling.

1. Remove left iAuCs® panel.

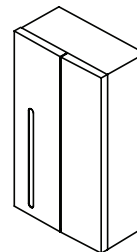

2. Unscrew nozzle/tubing from bottle, then remove bottle.
3. Remove bottle cap and foil seal from new bottle.
4. Install nozzle/tubing on new bottle.
5. Reinstall left panel.

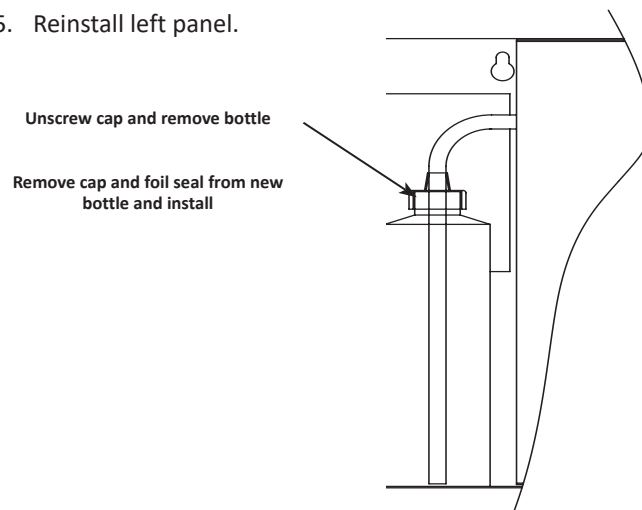

## Indigo® NXT Model Procedures

### INDIGO® NXT AUTOMATIC OPERATION

The following occurs when the ice machine is in ice making mode:

- A cleaning sequence starts when the time interval equals the Frequency of Cleaning setting of the iAuCS®.
- When the clean sequence is complete (approximately 35 minutes depending on model), ice making resumes until the next cleaning setpoint.

### INDIGO® NXT SETTING FREQUENCY OF CLEANING

1. Navigate to iAuCs® on the touchscreen: Menu/Settings/iAuCs®.
2. Use the arrows to select the frequency of cleaning - from once a month, up to once every six months.
3. Select On, then press the Home icon. Priming the pump is required if initial installation or the dispense hose does not contain cleaner or sanitizer.

### INDIGO® NXT HOSE PRIMING

The dispense pump requires priming after initial installation, or if the hose between the iAuCS® reservoir and pump has been pumped dry or the tubing between the iAuCS® pump and the ice machine has been pumped dry.

#### Warning

Do not blow into or suck on the hose in an attempt to prime it.

#### Important

iAuCS® does not operate when the CLEAN button is used to start a clean cycle. To prime the hose, activation is required through the Service Menu/iAuCS® icon.

Perform the following procedure:

1. Remove all ice from the evaporator(s) before priming.
2. Place a bottle of cleaner or sanitizer in the iAuCs® cabinet. Insert the pump inlet hose into the bottle and verify the pump outlet hose is correctly attached to the ice machine. Refer to “Installing/Replacing Cleaner or Sanitizer Bottles” on page 15.
3. Navigate to iAuCs® on the touchscreen: Menu/Service/iAuCs®.
4. Select On - A cleaning cycle will start by purging the water in the water trough. When the water trough refills and water contacts the water level probe, the iAuCs® pump will energize and prime the pump (touchscreen displays step 4).

NOTE: After the iAuCs® pump dispenses, the washing, rinsing and flushing cycles must complete before an ice making cycle can start.

5. The ice machine will turn off at the end of the cycle. To automatically start ice making when the cycle is complete, press the power button Off, then On during either the wash or rinse cycles. The clean cycle will resume from the beginning of either the washing or rinsing/flushing cycle, depending on the point of interruption.

**INDIGO® NXT MANUAL START OPERATION**

**Step 1** Ice must not be on the evaporator during the clean/sanitize cycle. Follow one of the methods below:

- Press the power switch at the end of a harvest cycle after ice falls from the evaporator(s).
- Press the power switch and allow the ice to melt.
- Use the touchscreen to initiate a manual harvest cycle Menu/Service/Manual harvest/press to start harvest.

**Step 2** Navigate to iAuCs® on the touchscreen: Menu/Service/iAuCs®/Select On

A cleaning cycle will start by purging the water in the water trough. When the water trough refills and water contacts the water level probe, the iAuCs® pump will energize (touchscreen displays step 4).

NOTE: After the iAuCs® pump dispenses, the washing, rinsing and flushing cycles must complete before an ice making cycle can start.

**Step 3** The ice machine will turn off at the end of the cycle. To automatically start ice making when the cycle is complete, press the power button Off, then On during the wash cycle (step 5 Washing is displayed). The clean cycle will resume from the beginning of the washing cycle and automatically start ice making when the clean cycle is complete.

**Important**

Opening the curtain switch will interrupt the clean sequence. The sequence will resume from the point of interruption when the curtain re-closes.

**INDIGO® NXT CHANGING THE SOLUTION TYPE****⚠ Caution**

Wear rubber gloves and safety goggles (and/or face shield) when handling Cleaner and Sanitizer.

**⚠ Caution**

Do not mix Cleaner and Sanitizer solutions together. It is a violation of Federal law to use these solutions in a manner inconsistent with their labeling.

**Notice**

Do not use 1 gallon bottles of Cleaner or Sanitizer on the iAuCS® accessory.

Use the following procedure to flush the system prior to changing from Cleaner to Sanitizer or from Sanitizer to Cleaner.

1. Remove all ice from the evaporators before proceeding.
2. Remove the bottle of Cleaner or Sanitizer from the iAuCS®. Flush the bottle thoroughly, then fill with water.
3. Repeat the following a minimum of two times:
  - A. Navigate to iAuCs® on the touchscreen and select : Menu/Service/iAuCs®.
  - B. A cleaning cycle will start by purging the water in the water trough. When the water trough refills and water contacts the water level probe, the iAuCs® pump will energize and prime the pump
4. Install a new bottle of cleaner or sanitizer solution. Refer to “Installing/Replacing Cleaner or Sanitizer Bottles” on page 15.

## Indigo® Model Procedures

### INDIGO® MODEL AUTOMATIC OPERATION

The following occurs when the ice machine is in ice making mode:

- A cleaning sequence starts when the time interval equals the Frequency of Cleaning setting of the iAuCS®.
- When the clean sequence is complete (approximately 25 minutes depending on model), ice making resumes until the next cleaning setpoint.

### SETTING FREQUENCY OF CLEANING INDIGO® MODELS

The iAuCS® unit is factory-set to initiate and complete a clean sequence approximately once every two weeks.

#### iAuCS®

For less frequent cleaning, use the controller to select an interval.

1. Press Menu.
2. Scroll to Setup and press right arrow.
3. Scroll to iAuCS Runtime and press right arrow.  
Display reads:  
iAuCS on  
iAuCS off  
Set interval  
Exit
4. Select iAuCS on and press check mark.
5. Select Set interval. Display reads:  
.5 mo  
1 mo  
2 mo  
3 mo  
4 mo  
5 mo  
6 mo  
Exit
6. Select desired time period and press check mark (15 days, 1 month, 2 months, etc.).
7. Press left arrow repeatedly to exit to Main screen.

### INDIGO® MODEL HOSE PRIMING

The dispenser pump requires priming after initial installation, or if the hose between the iAuCS® reservoir and pump has been pumped dry or the tubing between the iAuCS® pump and the ice machine has been pumped dry.

#### Warning

Do not blow into or suck on the hose in an attempt to prime it.

Perform the following procedure:

1. Press the CLEAN button.
2. The water pump and dump valve will turn on. The dump valve will shut off after approximately 45 seconds.
3. The control waits until water contacts the water level probe then energizes the iAuCS® pump (22" or 30" ice machines - 30 seconds, 48" ice machines - 60 seconds).
4. Allow the ice machine to complete the cleaning or sanitizing cycle.

#### **Important**

The priming procedure starts the automatic cleaning mode. After starting an ice making cycle, the ice machine will run through 6 rinse and dump cycles before making ice.

**INDIGO® MODEL CHANGING THE SOLUTION TYPE**

**⚠ Caution**

Wear rubber gloves and safety goggles (and/or face shield) when handling Cleaner and Sanitizer.

**⚠ Caution**

Do not mix Cleaner and Sanitizer solutions together. It is a violation of Federal law to use these solutions in a manner inconsistent with their labeling.

**Notice**

Do not use 1 gallon bottles of Cleaner or Sanitizer on the iAuCS® accessory.

Use the following procedure to flush the system prior to changing from Cleaner to Sanitizer or from Sanitizer to Cleaner.

1. Remove the bottle of Cleaner or Sanitizer from the iAuCS®. Flush the bottle thoroughly then fill with water.
2. Repeat the following until the water bottle is empty (approximately 8 times):
  - A. Press the CLEAN button.
  - B. The water pump and dump valve will turn on. The dump valve will shut off after approximately 45 seconds.
  - C. The control waits until the water contacts the water level probe then energizes the iAuCS® pump (22" or 30" ice machines - 30 seconds, 48" ice machines - 60 seconds).
  - D. Press the POWER button after step C is completed.
3. Install a new bottle of cleaner or sanitizer solution.

**INDIGO® MODEL MANUAL START OPERATION**

**Step 1** Press the power button after ice falls from the evaporator at the end of a Harvest cycle. Or, press the power button and allow the ice to melt off the evaporator.

**Notice**

Never use anything to force ice from the evaporator. Damage may result.

**Step 2** To start the automatic cleaning system, press the CLEAN button. The water will flow through the water dump valve and down the drain. The clean light will turn on to indicate the ice machine is in Clean Mode.

The iAuCS® pump energizes automatically to add cleaner or sanitizer to the ice machine.

**Step 3** The ice machine will automatically time out a wash cycle, followed by rinse cycles, and stop. This entire cycle lasts approximately 24 minutes for Indigo® Series.

**Step 4** The ice machine will start and finish the clean sequence, then automatically start ice making again.

**CHANGING SWITCH POSITION DURING OPERATION**

If a clean cycle is started and then stopped before the water inlet valve energizes or the water pump starts (45 seconds into the cycle), the clean cycle will be aborted.

If a clean cycle is started and then stopped after the water inlet valve energizes (more than 45 seconds into the cycle) and is then switched to:

<b>ICE MAKING</b>	The clean sequence resumes from the point of interruption. After completion of the cleaning sequence, the counter resets and the ice machine starts making ice.
<b>CLEAN</b>	The clean sequence resumes from the point of interruption. After the clean cycle is complete, the ice machine will stop and wait until either Ice Making or Clean is manually selected.

After the iAuCs® pump energizes, the ice machine must complete the wash and rinse cycles before ice making can start.

## Removal from Service/Winterization

### Notice

Leaving solutions in the iAuCS® in freezing temperatures may result in severe damage to the dispensing pump. A failure of this nature is not covered by the warranty.

If the iAuCS® is to be removed from service for extended periods, or if it is to be exposed to ambient temperatures 32°F (0°C) or below, follow this procedure:

1. Remove the Cleaning or Sanitizing solution bottle.
2. Follow the instructions for your model ice machine to pump all of the solution out of the dispensing pump and lines:
  - “Indigo® NXT Hose Priming” on page 16
  - “Indigo® Model Hose Priming” on page 18







**WELBILT®**  
*Bringing innovation to the table***WWW.WELBILT.COM**

Welbilt provides the world's top chefs, and premier chain operators or growing independents with industry leading equipment and solutions. Our cutting-edge designs and lean manufacturing tactics are powered by deep knowledge, operator insights, and culinary expertise. All of our products are backed by KitchenCare® – our aftermarket, repair, and parts service.

▶ CLEVELAND

▶ CONVOTHERM®

▶ DELFIELD®

▶ FITKITCHEN™

▶ FRYMASTER®

▶ GARLAND

▶ KOLPAK®

▶ LINCOLN

▶ MANITOWOC®

▶ MERCO®

▶ MERRYCHEF®

▶ MULTIPLEX®