

The Cisco® Connected Stadium solution is enabling stadiums across the globe to address evolving market trends and fan needs with next-generation sports and entertainment experiences. As a converged, highly scalable, secure platform, the Cisco Connected Stadium solution brings together all forms of access, communications, entertainment and operations to deliver next-generation sports and entertainment experiences.

The Cisco Connected Stadium solution provides a media-ready IP infrastructure that is optimized for video distribution. Moreover, the Cisco Connected Stadium solution accommodates all aspects of your business: integrated communications and collaboration, mobile services, and safety and security. Prominent venues around the world, such as Cowboys Stadium, Yankee Stadium, the New Meadowlands, and Croke Park, are already using the Cisco Connected Stadium solution to capitalize on these opportunities.

Cisco Connected Stadium Benefits

The Cisco Connected Stadium solution is the foundation for stadium operations. It provides a single, converged platform for innovation that delivers the capabilities required to enhance the experience of fans and business customers, to improve the operational efficiency of employees and vendors, and to allow venues to capitalize current and future growth opportunities.

Incorporating advanced technologies, such as Cisco Unified Communications, and Cisco Wireless LAN (WLAN) Mobility, as well as leading-edge solutions, such as the Cisco StadiumVision™, Connected Stadium Wi-Fi, and StadiumVision Mobile solutions, the Cisco Connected Stadium solution offers:

- Wireless connectivity to enable fan interaction and participation
- High-speed wired and wireless networks for the internal staff with guest access for vendors, contractors, press and media and luxury suite visitors

- A secure ticketing and point-of-sale (POS) infrastructure
- State-of-the-art voice services infrastructure
- Fully redundant, high performance multicast network supporting streaming video enabled by the Cisco StadiumVision and StadiumVision Mobile solutions
- Integrated physical security including video surveillance, access control and radio communications
- Connectivity for stadium Building Management Systems (BMS), including heating, ventilation, and air conditioning (HVAC)

Enhanced Fan Experience

With the Cisco Connected Stadium solution as the platform, venues can transform the fan experience with a variety of new services. The possibilities are numerous. For example:

- Teams can keep fans engaged with more immersive use of video throughout the venue, offer fans at the stadium faster access to the venue, offer them the ability to upgrade and resell their tickets, and even provide directions to their seats on their mobile devices.
- As fans move through the venue, digital displays deliver relevant event video and information. These displays can even communicate the location of their favorite foods or merchandise, or even the nearest restroom.
- Fans have more amenities available at their fingertips. They can order merchandise and concessions and be notified when they are ready for delivery or pickup, enabling them to spend more time enjoying the game.

Cisco Connected Stadium Solution

- Fans can even stay connected to the Internet for work or personal use. For example, fans can access new video options, including multiple camera angles and personal video, check other sports scores or even check their email using the guest network.
- Fans in the venue bowl can get reliable Wi-Fi access to data applications along with improved 3G/4G voice and texting services.

The Cisco Connected Stadium solution also enables the integration of Cisco TelePresence™ systems. With the Cisco TelePresence system, the venue can become an office away from the office. Luxury suite owners can conduct business meetings before, after or even during the event—from the venue—using the Cisco TelePresence system in their suite. Fans in premium clubs can access a virtual concierge service through the Cisco TelePresence system to aid in post event dinner reservations, special arrangements for a future event, or even alterations to travel plans.

Improved Operational Efficiencies

Not only are the fans, merchants, and venue staff networked through the Cisco Connected Stadium solution, the platform itself provides feedback and actionable information to its many systems—enabling improved operational efficiencies in the venue. For example:

- You can manage all the fan-facing communications from a single console, eliminating the need for inefficient manual controls. You can display real-time weather, exit, and traffic information to facilitate smoother crowd management.
- Physical access control and surveillance equipment are integrated along with first-responder communications, providing superior situational awareness and improving incident response time.
- Building automation systems can be driven from central data servers to maximize efficiencies and minimize operating costs. This setup, in turn, yields a greener venue that conserves energy to lower costs even further.

Growth and Investment Protection

The Cisco Connected Stadium solution enables venues to realize new and expanded revenue streams by providing technologies and solutions that enable customization of the venue and encourage fans to arrive earlier, stay later, and spend more while there.

In addition, the convergence of applications, devices, and solutions onto a single, scalable, flexible Cisco Connected Stadium platform optimizes a venue's ability to more rapidly deploy solutions, features and technologies that enable them to capture existing and new business opportunities.

And because the design provides a foundation on which a variety of solutions can be deployed, the Cisco Connected Stadium solution helps ensure investment protection for the long term while enabling venues to innovate at their own pace—adding new solutions and services when desired to adapt to changing markets and fan needs.

Cisco Connected Stadium Solution Components

The Cisco Connected Stadium solution provides a robust, secure, flexible platform that enables a multitude of add-on solutions to address all of the communications needs of the venue (Figure 1).

Figure 1. Cisco Connected Stadium Network

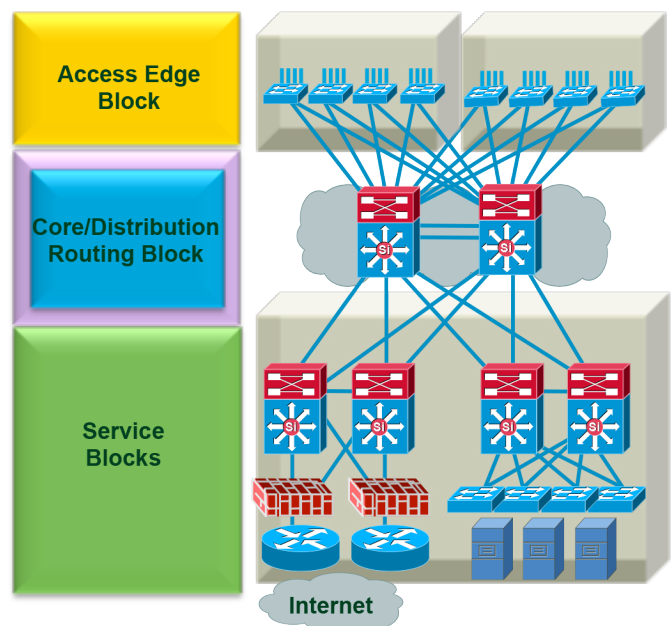

Connected Stadium Network Architecture

The Cisco Connected Stadium solution uses a hierarchical and modular architecture, including a collapsed core/distribution layer, an access layer, and a set of Service Blocks for delivering services to the network.

- The core/distribution layer consists of fully redundant pair of switches and provides the high-speed, redundant switching of packets traversing the network.
- The access layer provides ports for network devices such as IP phones, digital media players, wireless access points, video surveillance cameras, point of sale and ticketing terminals to connect to the network. Services are segregated using VLANs to contain traffic within confined work areas and avoid broadcast or Layer 2 network problems from affecting other areas.

Cisco Connected Stadium Solution

- Service blocks provide the services required for the different applications used over the network. Using this modular approach with dedicated switches simplifies expansion and operations and reduces the impact to the rest of the network during troubleshooting or software upgrades.

There are two basic core design options recommended using the Connected Stadium architecture. See Figure 2.

- One design uses Layer 3 routed links to the access layer. In this design, VLANs are terminated in the access layer switches with a Switched Virtual Interface (SVI). This provides for a very scalable and stable design where VLANs are isolated to that access layer IDF switch.
- The second design uses Layer 2 switched links to the access layer. This design extends the access VLANs across an 802.1q trunk to the core switch where they are

terminated with an SVI. This is the most flexible design where either Nexus or the 6500 VSS may be used as the core switches and where VLANs that must traverse the network for Layer 2-only applications, like Cobranet, can easily be accommodated.

Each of these core designs can use a dual-chassis or single-chassis option depending on desired resilience, number of IDF access layer switches to be terminated, and the available rack space to accommodate the core switches. The single chassis option must be configured with redundant supervisors, power supplies, and line cards to provide the highest availability for this option.

Figure 2. Connected Stadium Core Options

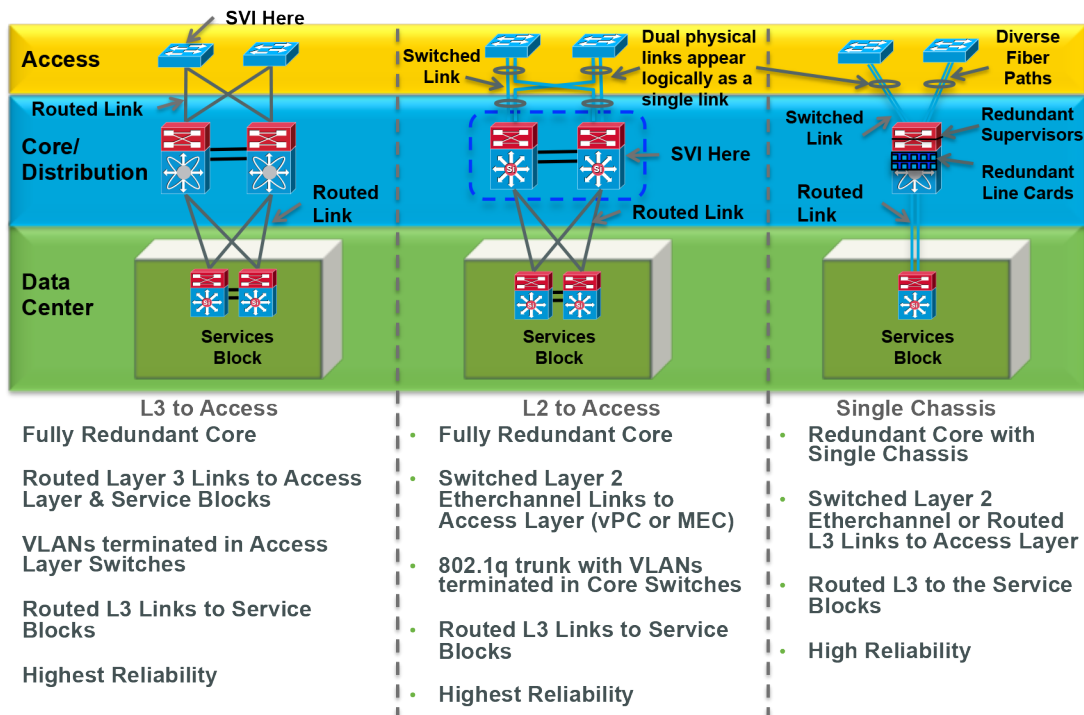

Connected Stadium Solution and Application Support

The Cisco Connected Stadium Network is the convergence point for the variety of Cisco solutions and applications used in sports or entertainment venues. Some of these solutions and applications are described below.

Cisco StadiumVision

The Cisco Connected Stadium solution provides the capabilities, reliability, and performance required to deliver HD video throughout the venue. The Cisco StadiumVision solution (currently available in the United States and Canada; Europe, including the United Kingdom and Ireland; Australia and New Zealand; and Latin America) can be deployed on top of the Cisco Connected Stadium solution to enable the delivery of in-house and external high-definition (HD) video feeds along with other digital content (that is advertisements and promotions, concession menus, and directional signage) to video endpoints throughout the venue.

A central HD video headend system allows live in-house camera feeds, terrestrial and satellite or cable channels to be distributed throughout the network to a Cisco Digital Media Player, which you can attach to virtually any type of TV or display. Displays can be located across concourse areas; in concession or retail areas; in luxury or prestige suites; in clubs, restaurants or bars; as well as in press boxes and back offices.

Cisco StadiumVision Director provides centralized, scripted management of the displays including control of the video feeds along with multiple options for overlaid advertisements and other digital content. You can segment content on a per-TV or group basis, delivering targeted content to different areas of the venue. In addition to centralized control, local TV control is enabled in the luxury suites, bars, clubs, and restaurants to provide guests with more customized experiences. Luxury suites also have the option of integrating with the POS service for simplified ordering of food, beverages, and merchandise by luxury-suite guests.

In areas where the Cisco StadiumVision solution is not yet available, there are alternative video delivery options that enable the distribution of video and digital content to displays throughout the venue. Contact your Cisco account manager for more information about video delivery options available in your area.

Cisco Connected Stadium Wi-Fi

The Cisco Connected Stadium Wi-Fi solution delivers high capacity and blanket wireless coverage throughout a stadium to support a mix of back-office and fan access applications. The solution extends the Connected Stadium network using

new and proven Cisco products and technologies in a unique design. The Wi-Fi network now supports access for stadium staff, wireless IP phones, wireless ticket and PoS scanners for ticketing and concessionaires, and guests and fans accessing the Internet. Fans now have reliable access to an increased array of data applications that work well over a high-capacity wireless network. In addition, due to the data offload, voice and text services are improved. With the improved coverage and capacity, clubs and leagues have expanded options for creating more engaging mobile applications to enhance the fan experience. Clubs and leagues can provide access to exclusive, in-venue, experience-enhancing applications for way-finding, food and beverage purchase, and more. The Connected Stadium Wi-Fi network is the prerequisite and foundation for delivering data intensive applications to the thousands of Wi-Fi users in Sports and Entertainment venues.

Cisco StadiumVision Mobile

The Cisco StadiumVision Mobile solution extends the video streaming capabilities of StadiumVision by delivering rich media content over a high-density wireless environment to the fan's mobile device. The same video content (whether in-house video or commercial broadcast feeds from a service provider) can be sent to both the StadiumVision HD displays and StadiumVision Mobile-enabled fan devices. The Connected Stadium Wi-Fi network built on top of the Connected Stadium wired network deliver high-quality, low-latency video to thousands of mobile devices by the combination of RF fine tuning, multicast and quality of service features all working in harmony.

Cisco Unified Communications

Public phone access, internal voice and video communications, as well as conferencing are provided using the Cisco Unified Communications Solution. Call control is centralized through a call management system (Cisco Unified Communications Manager) and voice gateways (Cisco 3945 Integrated Services Router) for public-switched-telephone-networks (PSTN) call connections. Video conferencing systems (including Cisco TelePresence systems) allow secure player interviews with fans and press and internal stadium communication as necessary. To simplify deployment, Cisco Unified IP Phones can use 802.3af Power over Ethernet (PoE).

When deployed with the Cisco StadiumVision solution, the Cisco IP Phone also provides local TV control and touch-screen access to concession and merchandise menus in the luxury suites.

Ticketing

The Cisco Connected Stadium solution can integrate with the venue's ticketing system, such as TicketMaster and Tickets.com, to provide control of fan and guest access within the stadium. This integration supports ticket sales as well as access to stands and club rooms.

The ticketing architecture is typically placed securely within the Cisco Connected Stadium Data Center. You can configure a unique ticketing VLAN on a redundant pair of data center switches, providing network connectivity to the critical ticketing resources within the data center environment.

The ticketing applications are run from internal venue PCs that connect to the access layer. This ticketing traffic is delivered through the Cisco Connected Stadium solution to the ticketing servers.

Point of Sale

Integrating the Cisco Connected Stadium solution with the venue concourse POS system (such as Radiant)—including terminals and cash registers, finishing kitchens, and wireless order entry devices—provides easy access to food and retail systems for fans, increasing revenue generating opportunities while also providing a cost savings over using separate infrastructures.

Optionally, integrating the Cisco StadiumVision solution with the venue luxury-suite POS system (such as Quest and Micros) allows guests, or suite attendants, in luxury suites to place orders for food, beverages and merchandise using the touch screen of their Cisco IP Phone—enhancing the total luxury-suite experience.

Safety and Security

You can deploy Cisco Physical Security products and solutions on top of the Cisco Connected Stadium solution allow venues to improve the security of their staff, fans, and property, while reducing operating expenses. You can deploy the Cisco Video Surveillance solution to ticketing and entrance areas, concession areas, back-office operational areas, loading docks, and building entries and exits to accelerate response to suspicious behaviors or incidents.

Cisco Video Surveillance IP cameras include HD and standard-definition (SD) IP cameras. In theft-prone areas, such as concession stands and ticket booths, you can set the cameras to continuously record or stream video images. For other areas, you can set the IP video surveillance system to "Record on Motion". With Record on Motion, when an IP camera detects motion in its viewing area it begins to record and stream the image back to an archive server, which can be located in the data center or within the same Intermediate Distribution frame (IDF) location. When there is no motion, the cameras do not send any video images across the network. To simplify deployment, the cameras can be powered with 802.3af PoE.

In addition, Cisco Physical Access Gateways can connect door locks and card readers to the IP network and allow venues to incorporate their existing physical security systems into the Cisco Connected Stadium solution. The access gateways can control of up to thousands of doors, including the ability to cache and encrypt up to 250,000 credentials per device. In addition, venues can automatically link the gateway sensors to the relevant video feeds through built-in integration with Cisco Video Surveillance Manager.

To further enhance the level of security provided to fans and staff, you can use Cisco IP Interoperability and Collaboration System (IPICS) to integrate communications between first responders. Cisco IPICS allows venues to automate communications to IP phones, push-to-talk media clients, radios, paging systems, and other emergency communications systems used in the venue to enable faster incident response time.

Cisco Services for the Cisco Connected Stadium

Realize the full business value of your Cisco Connected Stadium investment with smart, personalized services from Cisco. Cisco Services for the Cisco Connected Stadium solution incorporate architecture planning, solution design, and implementation services. These services are designed to help facilitate a smooth deployment and ongoing maintenance of the solution, including hardware coverage and software upgrades. For more information about Cisco Services for the Connected Stadium solution, please contact your Cisco Account Manager.

Cisco Connected Stadium Solution Features

Table 1. Cisco Connected Stadium Solution Features

| | |
|-----------------------------|---|
| High availability | <ul style="list-style-type: none"> • Redundant switches • Unidirectional Link Detection Protocol (UDLD) • EIGRP with fast convergence • Spanning Tree Protocol with Rapid Per VLAN Spanning Tree (PVST) • Nonstop Forwarding with Stateful Switchover (NSF/SSO) |
| Scalability | <ul style="list-style-type: none"> • High Performance Core Layer Switches with varying 1 or 10 Gigabit port densities • Stackable 24 and 48 port Access Layer Switches with 1 or 10 Gigabit uplinks • PoE+ with up to 30W per port on any of the Access Layer Switch options |
| Network segmentation | <ul style="list-style-type: none"> • VLANs • 802.1q VLAN trunking • multipoint generic routing encapsulation (mGRE) • Virtual Route Forwarding Lite (VRF-Lite) |
| Performance | <ul style="list-style-type: none"> • 10 Gigabit Ethernet links • Advanced quality of service (QoS) • IP Multicast |
| Network security | <ul style="list-style-type: none"> • Catalyst Security Features (IEEE 802.1AE MACsec, ACLs (VLAN, port-based and IP), Port Security, DHCP Snooping, Dynamic ARP Inspection, IP Source Guard, 802.1X, and many other embedded security features) • Payment Card Industry (PCI) compliance (Cisco ASA Firewalls and Intrusion Prevention System [IPS]) • Firewalls (Cisco ASA) and VPNs • Hardware-assisted Advanced Encryption Standard (AES) encryption (IEEE 802.11i and WPA2) |
| Video delivery | <ul style="list-style-type: none"> • HD or SD • MPEG-2 or MPEG 4 • In-house, terrestrial, or satellite and cable sources • Central or local control |

Cisco Connected Stadium Solution Components

Tables 2 and 3 outline the components of the Cisco Connected Stadium solution.

Table 2. Cisco Connected Stadium Solution Components

| | |
|-------------------------------|---|
| Layer 3 Infrastructure | <ul style="list-style-type: none"> • Core Layer (for Medium to Very Large Venues)—Nexus 7000 Series Switches (with Enterprise Services software) • Core Layer (for Medium to Large Venues)—Cisco Catalyst 6500 Series Switches (with IP Services or higher Software) • Core Layer (for Small to Medium Venues)—4500 Series Switches (with Enterprise Services software) • Access Layer—Cisco Catalyst 3750-X (L2/L3 stackable, PoE), 3560-X (L2/L3 fixed, PoE), or 2960S (L2 stackable, PoE) Series Switches. All available with 1 or 10 Gigabit Ethernet Uplinks |
| Data center | <ul style="list-style-type: none"> • Cisco Catalyst 6500 Series Switches with Cisco IOS Software IP Services image |
| Video delivery | <p>Cisco StadiumVision Solution (currently available in United States and Canada; and Europe, including the United Kingdom and Ireland; Australia/New Zealand; Latin America; alternative video delivery options are available in other areas)</p> <ul style="list-style-type: none"> • Cisco StadiumVision Director • Cisco Digital Media Player 4310G • Cisco encoders, transcoders, and receivers (dependent on video feeds) • Cisco Catalyst 3560-E Series or Catalyst 6500 Series Switches (video distribution switches) <p>Refer to the <i>Cisco StadiumVision Solution Data Sheet</i> for more information.</p> <p>Cisco StadiumVision Mobile Solution, providing scalable video delivery to mobile Wi-Fi devices (e.g., mobile phones and tablet computers)</p> <p>Components include</p> <ul style="list-style-type: none"> • Cisco StadiumVision Mobile Streamer • Cisco StadiumVision Mobile Encoder • Cisco StadiumVision Mobile Software Developers Kit (SDK) <p>Refer to the <i>Cisco StadiumVision Mobile Solution Data Sheet</i> for more information.</p> |
| Voice services | <p>Cisco Unified Communications Solution</p> <ul style="list-style-type: none"> • Cisco Unified Communications Manager 6.1, 7.1, or 8.5 • Cisco IP Phone 7900 Series (Cisco Unified IP Phone 7975 required for use with Cisco StadiumVision solution) • Cisco Emergency Responder 7.0, 7.1, 8.0, or 8.5 • Cisco 3945 Integrated Services Router (for Voice Gateway Services) |
| Video conferencing | <ul style="list-style-type: none"> • Cisco TelePresence conferencing |
| Network security | <ul style="list-style-type: none"> • Cisco Adaptive Security Appliance (ASA) • Cisco Intrusion Prevention System (IPS) • Cisco Identity Services Engine • Cisco Network Registrar (CNR) |
| Physical security | <ul style="list-style-type: none"> • Cisco IP Video Surveillance solution • Cisco Physical Access Gateways |
| WLAN access | <ul style="list-style-type: none"> • Cisco Aironet 3500 and 3600 Series Access Points • Cisco 5508 Wireless LAN Controller (WLC) • Cisco Catalyst 6500 Cisco Series/7600 Series Wireless Services Module (WiSM2) |
| Central management | <ul style="list-style-type: none"> • Cisco Prime Infrastructure • Cisco Security Manager |

¹ Currently available in: US/Canada; Europe, including UK and Ireland; Australia/New Zealand; Latin America. Alternative video delivery options are available in other areas.

Table 3. Cisco Connected Stadium Supported Third-Party Integration

| | |
|-------------------------|--|
| POS Integration | <ul style="list-style-type: none">• Radiant Systems for Concourse POS integration• Micros Systems or Quest for Cisco StadiumVision Luxury Suite POS integration |
| Ticketing | <ul style="list-style-type: none">• TicketMaster or Archtics• Tickets.com |
| Local TV control | <ul style="list-style-type: none">• AMX• Crestron |

For More Information

For more information about the Cisco Connected Stadium solution and the benefits it provides or more information about the Cisco StadiumVision solution, please visit <http://www.cisco.com/web/strategy/sports/> or contact your local account representative.



Americas Headquarters
Cisco Systems, Inc.
San Jose, CA

Asia Pacific Headquarters
Cisco Systems (USA) Pte. Ltd.
Singapore

Europe Headquarters
Cisco Systems International BV Amsterdam,
The Netherlands

Cisco has more than 200 offices worldwide. Addresses, phone numbers, and fax numbers are listed on the Cisco Website at www.cisco.com/go/offices.