

# The DCode™ Universal Mutation Detection System

Catalog Numbers  
170-9080 through 170-9104

**BIO-RAD**

## Warranty

The DCode universal mutation detection system lid, tanks, casting stand, gradient mixer, and accessories are warranted against defects in materials and workmanship for 1 year. If any defects occur during this period, Bio-Rad will repair or replace the defective parts at our discretion, without charge. The following defects, however, are excluded:

1. Defects caused by improper operation.
2. Repair or modification done by anyone other than Bio-Rad Laboratories or an authorized agent.
3. Damage caused by substituting alternative parts.
4. Use of fittings or spare parts supplied by anyone other than Bio-Rad Laboratories.
5. Damage caused by accident or misuse.
6. Damage caused by disaster.
7. Corrosion caused by improper solvent<sup>†</sup> or sample.

This warranty does not apply to parts listed below:

- Fuses
- Glass plates
- Electrodes

For any inquiry or request for repair service, contact Bio-Rad Laboratories. Inform Bio-Rad of the model and serial number of your instrument.

**Important:** This Bio-Rad instrument is designed and certified to meet EN61010-1\* safety standards. Certified products are safe to use when operated in accordance with the instruction manual. This instrument should not be modified or altered in any way. Alteration will:

- Void the manufacturer's warranty
- Void the EN61010-1 safety certification
- Create a potential safety hazard

Bio-Rad Laboratories is not responsible for any injury or damage caused by the use of this instrument for purposes other than those for which it is intended, or by modifications of the instrument not performed by Bio-Rad Laboratories or an authorized agent.

The Model 475 Gradient Delivery System is covered by U.S. patent number 5,540,498.

Practice of PCR is covered by U.S. patent numbers 4,683,195; 4,683,202; 4,899,818 issued to Cetus Corporation, which is a subsidiary of Hoffmann-LaRoche Molecular Systems, Inc. Purchase of any of Bio-Rad's PCR-related products does not convey a license to use the PCR process covered by these patents. To perform PCR, the user of these products must obtain a license.

© 1996 Bio-Rad Laboratories

All Rights Reserved

<sup>†</sup> The DCode system tank is not compatible with chlorinated hydrocarbons (e.g., chloroform), aromatic hydrocarbons (e.g., toluene, benzene), or acetone. Use of organic solvents voids all warranties.

\* EN61010-1 is an internationally accepted electrical safety standard for laboratory instruments.

# Table of Contents

<b>Section 1</b>	<b>General Safety Information</b> .....	<b>1</b>
1.1	Caution Symbols.....	1
1.2	Precautions During Set-up.....	1
1.3	Precautions During a Run.....	1
1.4	Precautions After a Run.....	2
1.5	Safety .....	2
<b>Section 2</b>	<b>Introduction</b> .....	<b>2</b>
2.1	Introduction to Mutation Detection Technology.....	2
<b>Section 3</b>	<b>Product Description</b> .....	<b>2</b>
3.1	Packing List .....	2
3.2	System Components and Accessories.....	5
<b>Section 4</b>	<b>Denaturing Gel Electrophoresis (DGGE, CDGE, TTGE)</b> .....	<b>11</b>
4.1	Introduction to Denaturing Gradient Gel Electrophoresis (DGGE) .....	11
	Reagent Preparation.....	13
	Gel Volumes .....	15
	Sample Preparation .....	16
	Temperature Controller.....	17
	Preheating the Running Buffer .....	18
	Assembling the Perpendicular Gradient Gel Sandwich .....	18
	Casting Perpendicular Gradient Gels .....	22
	Assembling the Parallel Gradient Gel Sandwich .....	24
	Casting Parallel Gradient Gels .....	26
4.2	Introduction to Constant Denaturing Gel Electrophoresis (CDGE).....	28
	Reagent Preparation.....	29
	Gel Volumes .....	31
	Sample Preparation .....	31
	Temperature Controller.....	32
	Preheating the Running Buffer .....	33
	Assembling the CDGE Gel Sandwich .....	33
	Casting CDGE Gels.....	35
4.3	Introduction to Temporal Temperature Gradient Gel Electrophoresis (TTGE) .....	36
	Calculating the Run Parameters .....	37
	Reagent Preparation.....	38
	Gel Volumes .....	40
	Sample Preparation .....	40
	Preheating the Running Buffer .....	40
	Assembling the TTGE Gel Sandwich .....	40
	Temperature Controller.....	41
	Casting TTGE Gels.....	43
<b>Section 5</b>	<b>Heteroduplex Analysis</b> .....	<b>44</b>
5.1	Introduction to Heteroduplex Analysis .....	44
5.2	Reagent Preparation.....	45
5.3	Gel Volumes .....	47
5.4	Sample Preparation .....	48
5.5	Temperature Controller.....	48
5.6	Adding the Running Buffer .....	49
5.7	Assembling the Heteroduplex Analysis Gel Sandwich .....	50

5.8	Casting Heteroduplex Analysis Gels .....	51
<b>Section 6</b>	<b>Single-Stranded Conformational Polymorphism (SSCP) .....</b>	<b>52</b>
6.1	Introduction to SSCP .....	52
6.2	Reagent Preparation .....	54
6.3	Gel Volumes .....	56
6.4	Sample Preparation .....	56
6.5	Temperature Controller.....	57
6.6	Cooling the Running Buffer and Chiller Settings.....	58
6.7	Assembling the SSCP Gel Sandwich.....	58
6.8	Casting SSCP Gels .....	60
<b>Section 7</b>	<b>Protein Truncation Test (PTT).....</b>	<b>61</b>
7.1	Introduction to PTT .....	61
7.2	Reagent Preparation .....	62
7.3	Gel Volumes .....	64
7.4	Sample Preparation .....	64
7.5	Temperature Controller.....	65
7.6	Adding the Running Buffer.....	66
7.7	Assembling the PTT Gel Sandwich.....	66
7.8	Casting PTT Gels .....	68
<b>Section 8</b>	<b>Electrophoresis.....</b>	<b>69</b>
8.1	Assembling the Upper Buffer Chamber.....	69
8.2	Sample Loading.....	71
8.3	Running the Gel.....	71
8.4	Removing the Gel.....	73
8.5	Staining and Photographing the Gel .....	74
<b>Section 9</b>	<b>Troubleshooting Guide .....</b>	<b>75</b>
9.1	Equipment .....	75
9.2	Applications .....	77
<b>Section 10</b>	<b>Specifications.....</b>	<b>81</b>
<b>Section 11</b>	<b>Maintenance .....</b>	<b>82</b>
<b>Section 12</b>	<b>References.....</b>	<b>82</b>
<b>Section 13</b>	<b>Instruments and Reagents for Mutation Detection</b>	
	<b>Electrophoresis .....</b>	<b>83</b>

## Section 1 General Safety Information



### 1.1 Caution Symbols

Read the manual before using the DCode system. For technical assistance, contact your local Bio-Rad Office or in the U.S., call Technical Services at 1-800-4BIORAD (1-800-424-6723). DC power to the DCode system is supplied by an external DC voltage power supply. This power supply must be ground isolated so that the DC voltage output floats with respect to ground. All Bio-Rad power supplies meet this important safety requirement. Regardless of which power supply is used, the maximum specified operating parameters for the system are:

- Maximum voltage limit 500 VDC
- Maximum power limit 50 watts

AC current for controlling temperature to the system, and DC current for electrophoresis, provided by the external power supply, enter the unit through the lid assembly, which provides a safety interlock. DC current to the cell is broken when the lid is removed. Do not attempt to circumvent this safety interlock. **Always disconnect the AC cord from the unit and the cord from the DC power supply before removing the lid, or when working with the cell.**

### Definition of Symbols



Caution, risk of electric shock.



Caution



Caution, hot surface.

### 1.2 Precautions During Set-up

- Do not use near flammable materials.
- Always inspect the DCode system for damaged components before use.
- Always place the DCode system on a level bench-top.
- Always place the lid assembly on the buffer tank with the AC and DC power cords disconnected.
- Always connect the system to the correct AC and DC power sources.

### 1.3 Precautions During a Run

- Do not run the pump when it is dry. Always add buffer to the “Fill” line when pre-chilling and/or preheating the buffer; always keep the buffer below “Max” level during electrophoresis.
- Do not touch any wet surface unless all the electrical sources are disconnected.
- Do not put anything on the top surface of the DCode system module.



## 1.4 Precautions After a Run

- Always turn off power switches and unplug all cables to DC and AC sources. Allow the heater tube to cool down (approximately 1 minute) before removing it from the tank. The ceramic tube may be very hot after shut-down. Do not touch the ceramic tube after turning off the power.
- Do not cool the hot ceramic tube in cool liquids.
- Always store the electrophoresis/temperature control module on the aluminum DCode lid stand for maximum stability. Caution: the heater tube may be hot after use

## 1.5 Safety

This instrument is intended for laboratory use only

This product conforms to the “Class A” standards for electromagnetic emissions intended for laboratory equipment applications. It is possible that emissions from this product may interfere with some sensitive appliances when placed nearby or in the same circuit as those appliances. The user should be aware of this potential and take appropriate measures to avoid interference.

## Section 2 Introduction

### 2.1 Introduction to Mutation Detection Technology

Detecting single base mutations is of utmost importance in the field of molecular genetics. Screening for deletions, insertions, and base substitutions in genes was initially done by Southern blotting. Many techniques have been developed to analyze the presence of mutations in a DNA target. The most common methods include: Single-Strand Conformational Polymorphism<sup>1</sup> (SSCP), Denaturing Gradient Gel Electrophoresis<sup>2</sup> (DGGE), carbodiimide<sup>3</sup> (CDI), Chemical Cleavage of Mismatch<sup>4</sup> (CCM), RNase cleavage,<sup>5</sup> Heteroduplex analysis,<sup>6</sup> and the Protein Truncation Test<sup>7</sup> (PTT). A new technique for mutation detection is Temporal Temperature Gradient Gel Electrophoresis<sup>8</sup> (TTGE). Bio-Rad reduced this technique to a simple, reproducible method on the DCode system. TTGE uses a polyacrylamide gel containing a constant concentration of urea. During electrophoresis, the temperature is increased gradually and uniformly. The result is a linear temperature gradient over the course of the electrophoresis run. Many labs used combination of methods to maximize mutation detection efficiency.

The DCode system is a vertical electrophoresis instrument for the detection of gene mutations. The DCode system can be used to perform any vertical gel-based mutation detection method. The system is optimized for DGGE, CDGE, TTGE, SSCP, PTT and Heteroduplex Analysis. Some of the advantages of the DCode system include uniform buffer temperature around the gel, buffer circulation, buffer temperature runs from 5 to 70 °C and a modular design to allow customization.

## Section 3 Product Description

### 3.1 Packing List

The DCode system is shipped with the following components. If items are missing or damaged, contact your local Bio-Rad office.

### **The DCode System for DGGE (10 cm and 16 cm systems)**

<b>Item</b>	<b>Quantity</b>
Instruction manual	1
Warranty card (please complete and return)	1
Electrophoresis/temperature control module	1
Electrophoresis tank	1
Casting stand with sponges	1
Sandwich core	1
DCode lid stand	1
16 cm glass plates (16 cm system)	2 sets
10 cm glass plates (10 cm system)	2 sets
Sandwich clamps	2 sets
Spacers, grooved, 1 mm	2 sets
Middle spacer, 1 mm (10 cm system)	2
Prep comb, 1 well, 1 mm (16 cm system)	2
Prep comb, 2 well, 1 mm (10 cm system)	2
16-well comb, 1 mm	1
Comb gasket for 0.75 & 1 mm spacers	1
Comb gasket holder	1
Model 475 gradient former	1
Syringes: 10 ml, 30 ml	2 each
Tubing	3 feet
Luer couplings	4
Luer syringe locks	2
Syringe sleeves	4
Syringe cap screws	2
Y-fitting	5
Control reagent kit for DGGE, CDGE, TTGE	1

### **DCode System for CDGE**

<b>Item</b>	<b>Quantity</b>
Instruction manual	1
Warranty card (please complete and return)	1
Electrophoresis/temperature control module	1
Electrophoresis tank	1
Casting stand with sponges	1
Sandwich core	1
DCode lid stand	1
Glass plates, 16 cm	2 sets
Sandwich clamps	2 sets
Spacers, 1 mm	2 sets
20-well combs, 1 mm	2
Control reagent kit for DGGE, CDGE, TTGE	1

## **DCode System for TTGE**

<b>Item</b>	<b>Quantity</b>
Instruction manual	1
Warranty card (please complete and return)	1
Electrophoresis/temperature control module	1
Electrophoresis tank	1
Casting stand with sponges	1
Sandwich core	1
DCode lid stand	1
Glass plates, 16 cm	2 sets
Sandwich clamps	2 sets
Spacers, 1 mm	2 sets
20-well combs, 1 mm	2
Control reagent kit for DGGE, CDGE, TTGE	1

## **DCode System for SSCP**

<b>Item</b>	<b>Quantity</b>
Instruction manual	1
Warranty card (please complete and return)	1
Electrophoresis/temperature control module	1
Electrophoresis cooling tank	1
Casting stand with sponges	1
Sandwich core	1
DCode lid stand	1
Sandwich clamps	2 sets
Glass plates, 20 cm	2 sets
Spacers, 0.75 mm	2 sets
20-well combs, 0.75 mm	2
Control reagent kit for SSCP	1

## **DCode System for Heteroduplex Analysis**

<b>Item</b>	<b>Quantity</b>
Instruction manual	1
Warranty card (please complete and return)	1
Electrophoresis/temperature control module	1
Electrophoresis tank	1
Casting stand with sponges	1
Sandwich core	1
DCode lid stand	1
Sandwich clamps	2 sets
Glass plates, 20 cm	2 sets
Spacers, 0.75 mm	2 sets
20-well combs, 0.75 mm	2
Control reagent kit for Heteroduplex Analysis	1



## DCode System for Protein Truncation Test

Item	Quantity
Instruction manual	1
Warranty card (please complete and return)	1
Electrophoresis/temperature control module	1
Electrophoresis tank	1
Casting stand with sponges	1
Sandwich core	1
DCode lid stand	1
Sandwich clamps	2 sets
Glass plates, 20 cm	2 sets
Spacers, 1 mm	2 sets
20-well comb, 1 mm	2

### 3.2 System Components and Accessories

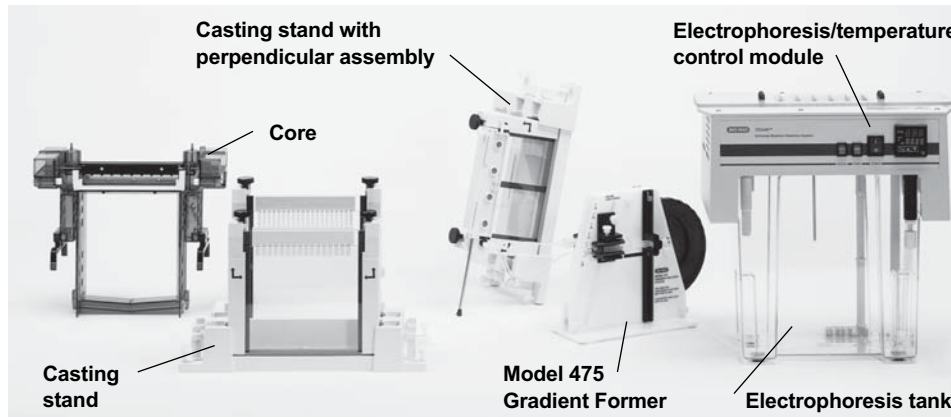

Fig. 3.1. The DCode system.

#### System Components and Accessories

	Description
Electrophoresis Tank	The electrophoresis tank is a reservoir for the running buffer.
Electrophoresis Cooling Tank (SSCP only)	The electrophoresis cooling tank has two ceramic cooling fingers inside the electrophoresis tank (Figure 3.2). Two quick-release connectors are connected to an external chiller to chill the running buffer. The electrophoresis cooling tank should not be used for heated buffer runs ( <i>i.e.</i> , DGGE, CDGE or TTGE).

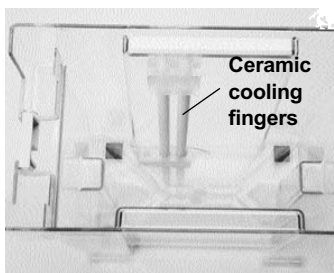

Fig. 3.2. Electrophoresis cooling tank.

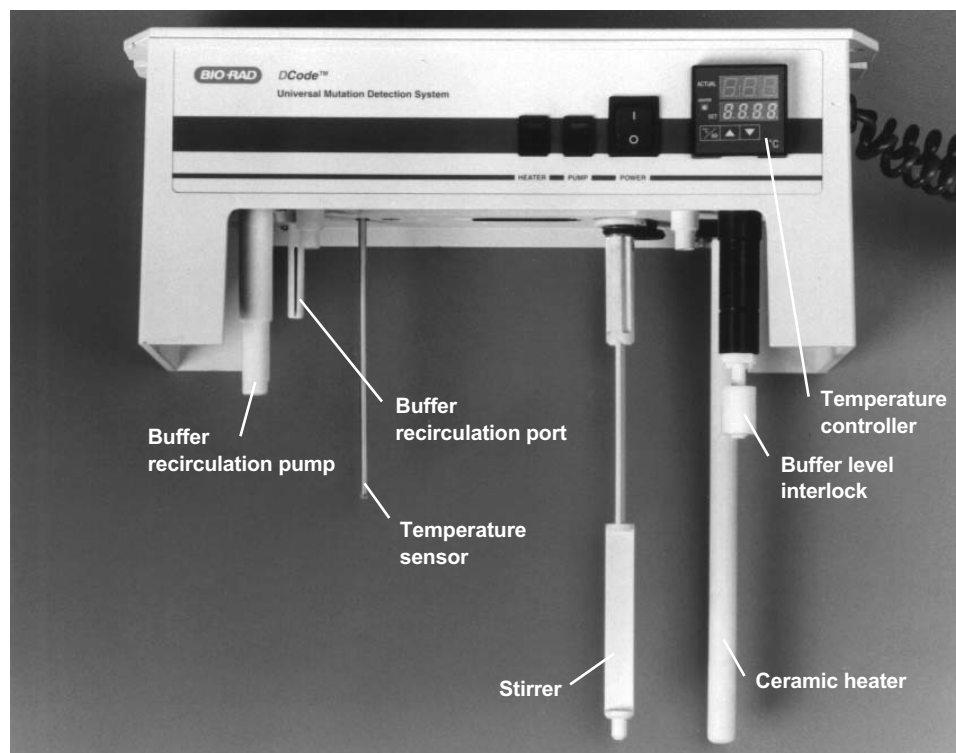

Fig. 3.3. Electrophoresis/Temperature Control Module.

**System Components and Accessories**

**Description**

Electrophoresis/Temperature Control Module

The control module contains the heater, stirrer, pump, and electrophoresis leads to operate the DCode system (Figure 3.3). Combined with the lower buffer tank, the control module acts to fully enclose the system. The control module should be placed so that the tip of the stirring bar fits inside the support hole of the tank. The clear loading lid is a removable part that contains four banana jacks which function as a safety interlock. It should be left in place at all times except while loading samples.

Core

The sandwich core holds one gel assembly on each side (Figure 3.4). When attached, each gel assembly forms one side of the upper buffer chamber. The inner plate is clamped against a rubber gasket on the core to provide a greaseless seal for the upper buffer chamber.

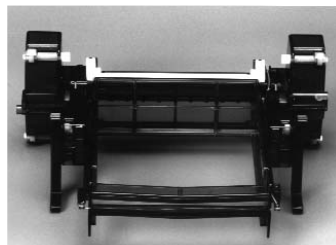

Fig. 3.4. Core

### Casting Stand

The casting stand holds the gel sandwich upright while casting a gel (Figure 3.5). With the cam levers engaged, the sponge seals the bottom of the gel while the acrylamide polymerizes.



Fig. 3.5. Casting Stand.

### Sandwich Clamps

The sandwich clamps consist of a single screw mechanism which makes assembly, alignment, and disassembly of the gel sandwich an effortless task. The clamps exert an even pressure over the entire length of the glass plates. A set consists of a left and right clamp.

### Alignment Card

The alignment card simplifies sandwich assembly by keeping the spacers in the correct position.

### Comb Gasket Holder

The comb gasket holder holds the comb gasket that prevents (DGGE only) leakage of acrylamide during gel casting (Figure 3.6). The front of the holder has two screws which are used to secure the comb gasket against the glass plate. The top of the comb gasket holder also has two tilt rod screws which control the position of the tilt rod during gel casting. The opposite side of the comb gasket holder has two vent ports. There are two sizes of comb gasket holder: a 1 mm size for 1 mm and 0.75 mm spacer sets and a 1.5 mm size for the 1.5 mm spacer set.

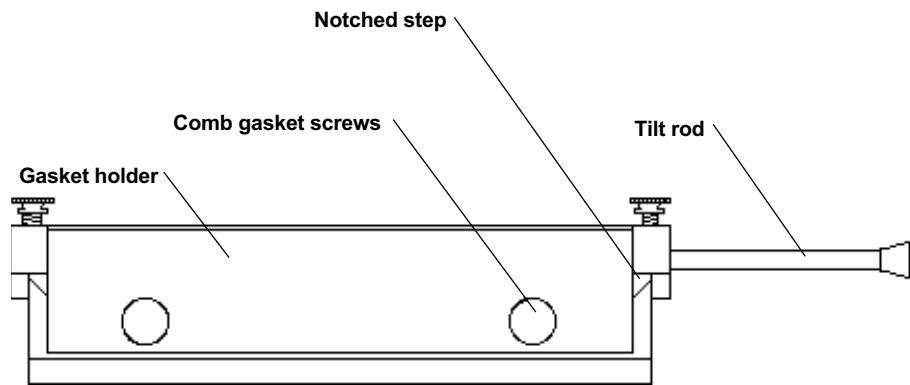
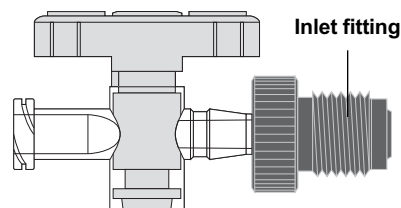

Fig. 3.6. Comb gasket holder.

Stopcocks (DGGE only)

The gel solution is introduced via the stopcock at the inlet port on the sandwich clamp when casting a perpendicular gel (Figure 3.7).



**Fig. 3.7. Stopcock**

Comb and Spacer Set

The 7.5 x 10 cm gel format consist of two “mirror image (DGGE only) spacers, one middle spacer and a dual prep comb for two 7.5 x 10 cm gels (Figure 3.8). The spacers have a groove and injection port hole for casting. The middle spacer between the two gels fits into the middle notch of the dual comb and allows the air to escape through the comb gasket holder vent port. The 16 x 16 cm gel format consist of two different spacers, one with the groove and injection port hole for casting and one with a short groove toward the injection port hole for air to escape. A single prep comb without a middle spacer is provided with the 16 x 16 cm gel format.

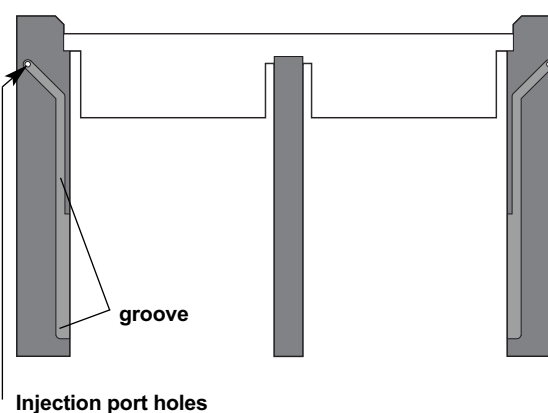

**Fig. 3.8. Dual prep comb and spacer set for two 7.5 x 10 cm gels.**

Comb and Spacer Set

Different types of combs and spacers are provided with the different DCode systems. Spacer lengths are 10 cm, 16 cm or 20 cm, with a thickness of 0.75 or 1.0 mm. Combs come with 16 or 20 wells and a thickness of 0.75 or 1.0 mm.

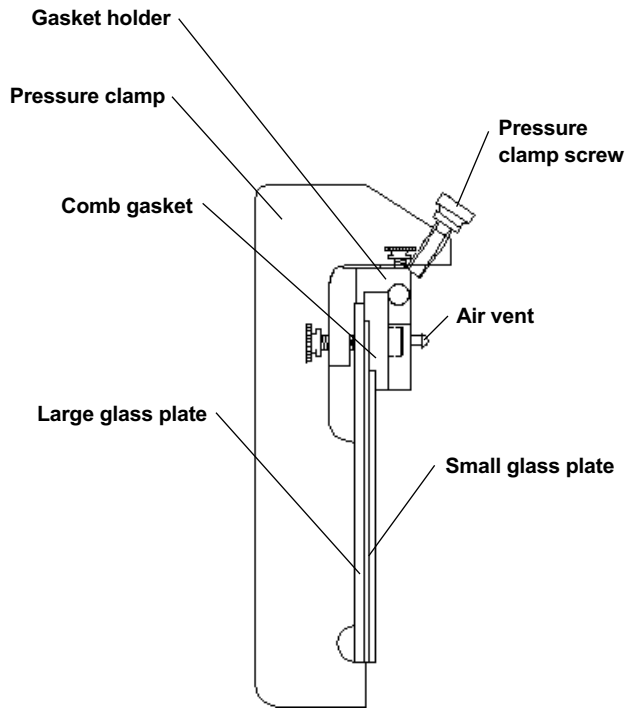

Fig. 3.9. Pressure clamp.

Pressure Clamp  
the (DGGE only)

The pressure clamp provides consistent pressure to comb gasket before securing it to the plate assembly to provide a seal (Figure 3.9).

DCode Lid Stand

The DCode lid stand provides a stand when the electrophoresis/temperature control module (lid) is not in use. The stand must be used to properly support and protect the lid components when the lid is not on the electrophoresis tank.

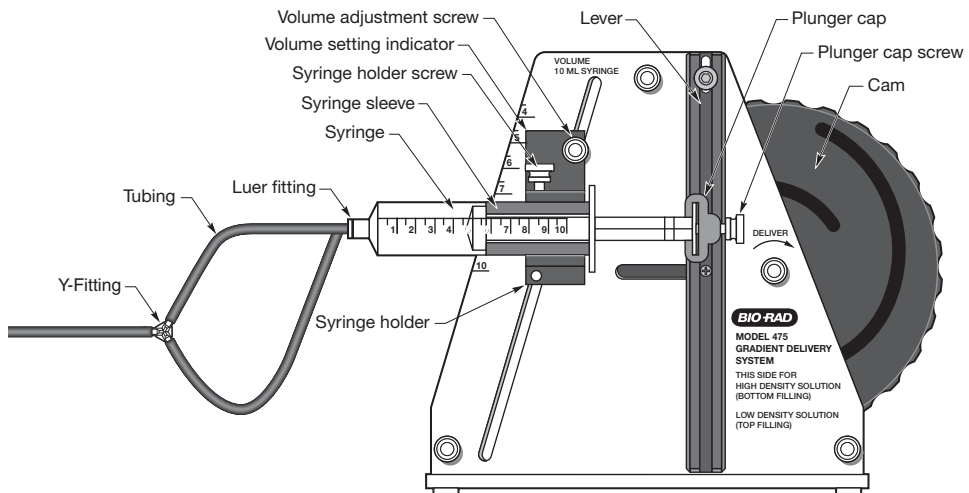

Fig. 3.10. Model 475 Gradient Delivery System.

## Model 475 System Components

	Description (DGGE System only)
Syringe	Two pairs each of 10 and 30 ml disposable syringes are provided. The 10 ml syringes are for gel volumes less than 10 ml. The 30 ml syringes are for gel volumes greater than 10 ml. For proper gel casting, use matching syringe sizes.
Plunger Caps/ Plunger Cap Screw	There are two plunger caps, one for each syringe. The plunger caps fit both the 10 and 30 ml syringes (Figure 3.11).
Lever Attachment Screw	The lever attachment screw is on the plunger cap. This screw fits into the groove of the lever and conducts the driving force of the cam in dispensing the gel solution.
Syringe Sleeve	One pair of syringe sleeves for each size syringe is provided (Figure 3.12). The sleeve is a movable adaptor to mount the syringe in the holder. The sleeve should conform to the syringe. If the syringe is too tight or too loose, adjust the sleeve by pushing or pulling.
Syringe Holder/ Syringe Holder Screw	The syringe holder is next to the lever. It holds the syringe in place and controls the delivery volume. The syringe is held in the holder by tightening the holder screw against the sleeve.
Volume Adjustment Screw	The volume adjustment screw is on both sides of the syringe holder (Figure 3.10). It adjusts the holder to the desired delivery volume.
Volume Setting Indicator	The volume setting indicator is at the top corner of the syringe holder nearest the volume setting numbers (Figure 3.10).
Lever	The position of the lever is controlled by the rotation of the cam (Figure 3.10). The lever must be in the vertical or start position before use.
Tygon Tubing	One length of Tygon™ tubing is provided. Cut the tubing into two 15.5 cm and one 9 cm lengths. The longer pieces are used to transport the gel solution from the syringes into the Y-fitting. The short piece will transport the gel solution from the Y-fitting to the gel sandwich.
Y-Fitting	The Y-fitting mixes the high and low density gel solutions (Figure 3.13).
Luer Fitting/Coupling	There are two luer fittings that fit both 10 and 30 ml syringes. The fittings twist onto the syringe and connect to the Tygon tubing on the other end. A luer coupling is used on one end of the 9 cm tubing to connect it to the gel sandwich stopcock.

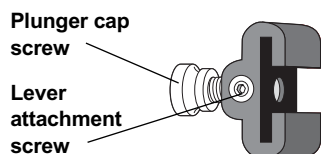

Fig. 3.11. Plunger Cap

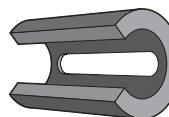

Fig. 3.12. Syringe sleeve

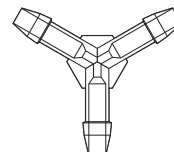
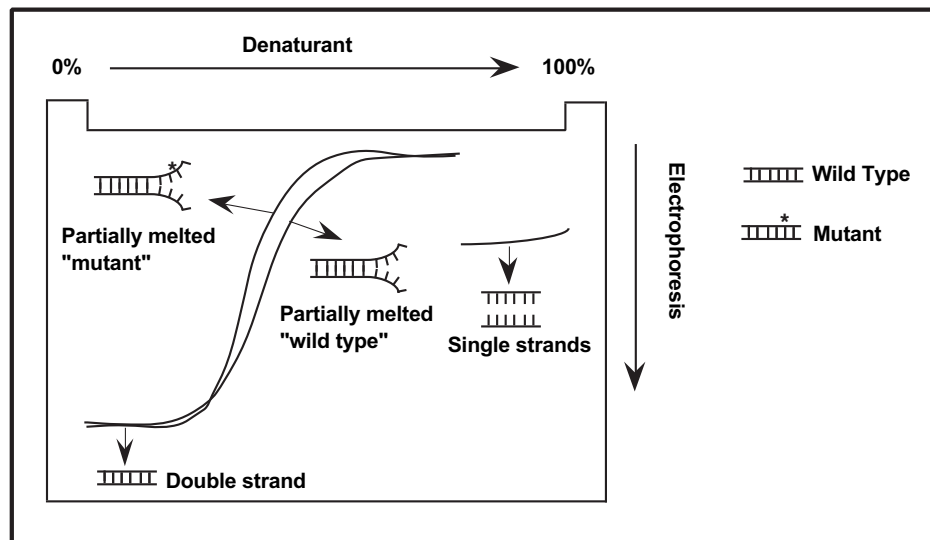

Fig. 3.13. Y-Fitting

## Section 4 Denaturing Gel Electrophoresis (DGGE, CDGE, TTGE)

### 4.1 Introduction to Denaturing Gradient Gel Electrophoresis (DGGE)

Denaturing Gradient Gel Electrophoresis (DGGE) is an electrophoretic method to identify single base changes in a segment of DNA. Separation techniques on which DGGE is based were first described by Fischer and Lerman.<sup>2</sup> In a denaturing gradient acrylamide gel, double-stranded DNA is subjected to an increasing denaturant environment and will melt in discrete segments called "melting domains". The melting temperature ( $T_m$ ) of these domains is sequence-specific. When the  $T_m$  of the lowest melting domain is reached, the DNA will become partially melted, creating branched molecules. Partial melting of the DNA reduces its mobility in a polyacrylamide gel. Since the  $T_m$  of a particular melting domain is sequence-specific, the presence of a mutation will alter the melting profile of that DNA when compared to wild-type. DNA containing mutations will encounter mobility shifts at different positions in the gel than the wild-type. If the fragment completely denatures, then migration again becomes a function of size (Figure 4.1).



**Fig. 4.1. An example of DNA melting properties in a perpendicular denaturing gradient gel.** At a low concentration of denaturant, the DNA fragment remains double-stranded, but as the concentration of denaturant increases, the DNA fragment begins to melt. Then, at very high concentrations of denaturant, the DNA fragment can completely melt, creating two single strands.

In DGGE, the denaturing environment is created by a combination of uniform temperature, typically between 50 and 65 °C and a linear denaturant gradient formed with urea and formamide. A solution of 100% chemical denaturant consists of 7 M urea and 40% formamide. The denaturing gradient may be formed perpendicular or parallel to the direction of electrophoresis. A perpendicular gradient gel, in which the gradient is perpendicular to the electric field, typically uses a broad denaturing gradient range, such as 0–100% or 20–70%.<sup>2</sup> In parallel DGGE, the denaturing gradient is parallel to the electric field, and the range of denaturant is narrowed to allow better separation of fragments.<sup>9</sup> Examples of perpendicular and parallel denaturing gradient gels with homoduplex and heteroduplex fragments are shown in Figure 4.2.

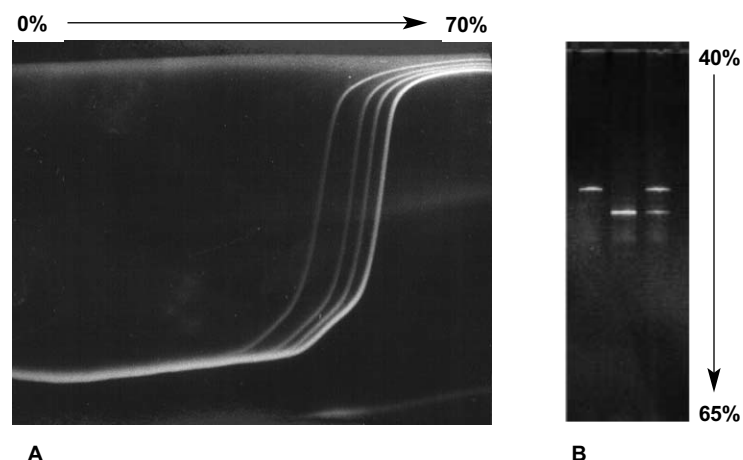

**Fig. 4.2. A. Perpendicular denaturing gradient gel in which the denaturing gradient is perpendicular to the electrophoresis direction.** Mutant and wild-type alleles of exon 6 from the TP53 gene amplified from primary breast carcinomas and separated by perpendicular DGGE (0–70% denaturant) run at 80 V for 2 hours at 56 °C. The first two bands on the left are heteroduplexes and the other two bands are the homoduplexes. **B. Parallel denaturing gradient gel in which the denaturing gradient is parallel to the electrophoresis direction.** Mutant and wild-type alleles of exon 8 from the p53 gene separated by an 8% acrylamide:bis (37.5:1) gel with a parallel gradient of 40–65% denaturant. The gel was run at 150 V for 2.5 hours at 60 °C in 1x TAE buffer. Lane 1 contains the mutant fragment, lane 2 contains the wild-type fragment, lane 3 contains both the mutant and wild-type fragments.

When running a denaturing gradient gel, both the mutant and wild-type DNA fragments are run on the same gel. This way, mutations are detected by differential migration of mutant and wild-type DNA. The mutant and wild-type fragments are typically amplified by the polymerase chain reaction (PCR) to make enough DNA to load on the gel. Optimal resolution is attained when the molecules do not completely denature and the region screened is in the lowest melting domain. The addition of a 30–40 base pair GC clamp to one of the PCR primers insures that the region screened is in the lower melting domain and that the DNA will remain partially double-stranded.<sup>34</sup> An alternative to GC clamps is using psoralen derivative PCR primers called ChemiClamp primers.<sup>10</sup> Because ChemiClamps covalently link the two DNA strands at one end, they should not be used when isolating a DNA fragment which is going to be sequenced from a gel. The size of the DNA fragments run on a denaturing gel can be as large as 1 kb in length, but only the lower melting domains will be available for mutation analysis. For complete analysis of fragments over 1 kb in length, more than one PCR reaction should be performed.<sup>11</sup>

The thermodynamics of the transition of double-stranded to single-stranded DNA have been described by a computer program developed by Lerman.<sup>12</sup> Bio-Rad offers a Macintosh® computer program, MacMelt™ software, which calculates and graphs theoretical DNA melting profiles. Melting profile programs can show regions of theoretical high and low melting domains of a known sequence. Placement of primers and GC clamps can be optimized by analysis of placement effect on the DNA melting profile.

The method of creating heteroduplex molecules helps in detecting homoduplex mutations. This process is typically done when it is not originally possible to resolve a homoduplex mutation. Analysis of heteroduplex molecules can, therefore, increase the sensitivity of DGGE. Heteroduplexes can be formed by adding the wild-type and mutant template DNAs in the same PCR reaction or by adding separate PCR products together, then denaturing and allowing them to re-anneal. A heteroduplex has a mismatch in the double-strand causing a distortion in its usual conformation; this has a destabilizing effect and causes the DNA strands to denature at a lower concentration of denaturant (Figure 4.3). The heteroduplex bands always migrate more slowly than the corresponding homoduplex bands under specific conditions.



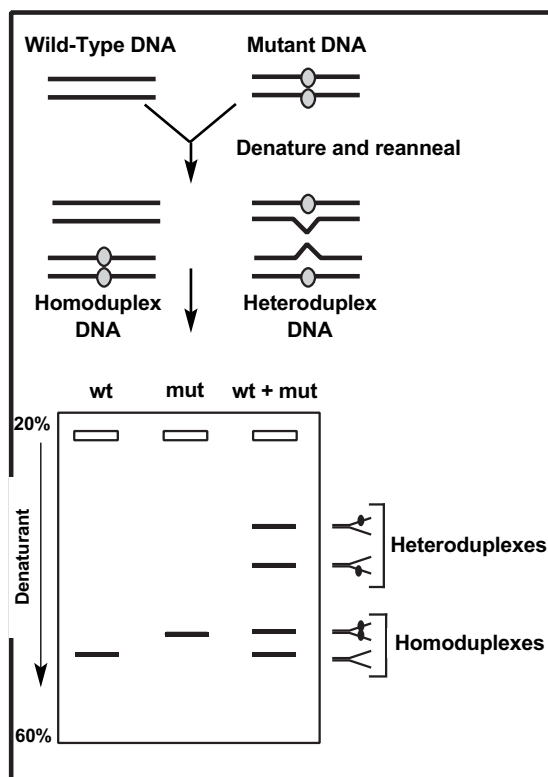

**Fig. 4.3. An example of wild-type and mutant DNA fragments that were denatured and re-annealed to generate four fragments: two heteroduplexes and two homoduplexes run on a parallel denaturing gradient gel.** The melting behavior of the heteroduplexes is altered so that they melt at a lower denaturant concentration than the homoduplexes and can be visualized on a denaturing gradient gel.

## Reagent Preparation

The concentration of denaturant to use varies for the sample being analyzed with the DCode system. Typically a broad denaturing gradient range is used, such as 0–100% or 20–70%. The concentration of acrylamide can also vary, depending on the size of the fragment analyzed. Both 0% and 100% denaturant should be made as stock solutions. A 100% denaturant is a mixture of 7 M urea and 40% deionized formamide. Reagents for casting and running a DGGE gel are included in the DCode Electrophoresis Reagent Kit for DGGE/CDGE, catalog number 170-9032.

For different percent crosslinking, use the equation below to determine the amount of Bis to add. The example stock solution below is for an acrylamide/bis ratio of 37.5:1.

### 40% Acrylamide/Bis (37.5:1)

Reagent	Amount
Acrylamide	38.93 g
Bis-acrylamide	1.07 g
dH <sub>2</sub> O	to 100.0 ml

Filter through a 0.45  $\mu$  filter and store at 4°C.

Polyacrylamide gels are described by reference to two characteristics:

- 1) The total monomer concentration (%T)
- 2) The crosslinking monomer concentration (%C)

$$\%T = \frac{\text{gm acrylamide} + \text{gm bis-acrylamide}}{\text{Total Volume}} \times 100$$

$$\%C = \frac{\text{gm bis-acrylamide}}{\text{gm acrylamide} + \text{gm bis-acrylamide}} \times 100$$

#### 50x TAE Buffer

Reagent	Amount	Final Concentration
Tris base	242.0 g	2 M
Acetic acid, glacial	57.1 ml	1 M
0.5 M EDTA, pH 8.0	100.0 ml	50 mM
dH <sub>2</sub> O	to 1,000.0 ml	

Mix. Autoclave for 20–30 minutes. Store at room temperature.

The table below provides the percentage acrylamide/bis needed for a particular size range.

Gel Percentage	Base Pair Separation
6%	300–1000 bp
8%	200–400 bp
10%	100–300 bp

#### 0% Denaturing Solution

		6% Gel	8% Gel	10% Gel
<b>12% Gel</b>				
40% Acrylamide/Bis	15 ml	20 ml	25 ml	30 ml
50x TAE buffer	2 ml	2 ml	2 ml	2 ml
dH <sub>2</sub> O	83 ml	78 ml	73 ml	68 ml
Total volume	100 ml	100 ml	100 ml	100 ml

Degas for 10–15 minutes. Filter through a 0.45 μ filter. Store at 4°C in a brown bottle for approximately 1 month.

#### 100% Denaturing Solution

			6% Gel	8% Gel
<b>10% Gel</b>		<b>12% Gel</b>		
40% Acrylamide/Bis	15 ml	20 ml	25 ml	30 ml
50x TAE buffer	2 ml	2 ml	2 ml	2 ml
Formamide (deionized)	40 ml	40 ml	40 ml	40 ml
Urea	42 g	42 g	42 g	42 g
dH <sub>2</sub> O	to 100 ml	to 100 ml	to 100 ml	to 100 ml

Degas for 10–15 minutes. Filter through a 0.45 μ filter. Store at 4°C in a brown bottle for approximately 1 month. A 100% denaturant solution requires re-dissolving after storage. Place the bottle in a warm bath and stir for faster results.

For denaturing solutions less than 100%, use the volumes for acrylamide, TAE and water described above in the 100% Denaturing Solution. Use the amounts indicated below for urea and formamide.

<b>Denaturing Solution</b>	<b>10%</b>	<b>20%</b>	<b>30%</b>	<b>40%</b>	<b>50%</b>	<b>60%</b>	<b>70%</b>	<b>80%</b>	<b>90%</b>
Formamide (ml)	4	8	12	16	20	24	28	32	36
Urea (g)	4.2	8.4	12.6	16.8	21	25.2	29.4	33.6	37.8

#### **10% Ammonium Persulfate**

<b>Reagent</b>	<b>Amount</b>
Ammonium persulfate	0.1 g
dH <sub>2</sub> O	1.0 ml

Store at –20°C for about a week.

#### **DCode Dye Solution**

<b>Reagent Concentration</b>	<b>Amount</b>	<b>Final</b>
Bromophenol blue	0.05 g	0.5%
Xylene cyanol	0.05 g	0.5%
1x TAE buffer	10.0 ml	1x

Store at room temperature. This reagent is supplied in the DCode electrophoresis reagent kit for DGGE, CDGE.

#### **2x Gel Loading Dye**

<b>Reagent Concentration</b>	<b>Amount</b>	<b>Final</b>
2% Bromophenol blue	0.25 ml	0.05%
2% Xylene cyanol	0.25 ml	
	0.05%	
100% Glycerol	7.0 ml	
70%		
dH <sub>2</sub> O	2.5 ml	
Total volume	10.0 ml	

Store at room temperature.

#### **1x TAE Running Buffer**

<b>Reagent</b>	<b>Amount</b>
50x TAE buffer	140 ml
dH <sub>2</sub> O	6,860 ml
Total volume	7,000 ml

## **Gel Volumes**

### **Linear Denaturing Gradient Gels**

The table below provides the required gradient delivery system setting per gel size desired. The volume per syringe is for the amount required for each low and high density syringe, and the volume adjustment setting sets the gradient delivery system for the proper delivery of solutions. The 7.5 x 10 cm and 16 x 16 cm size gels are recommended for the perpendicular gel formats, whereas the 16 x 10 cm and 16 x 16 cm gel formats are recommended for parallel denaturing gels. The volume per syringe requires a larger volume of reagent than the volume setting indicates, because the excess volume in the syringe is needed to push the correct amount of gel solution into the gel sandwich.

<b>Spacer Size</b>	<b>Gel Size</b>	<b>Volume per Syringe</b>	<b>Volume Adjustment Setting</b>
0.75 mm	7.5 x 10 cm	5 ml	3.5
	16 x 10 cm	8 ml	6.5
	16 x 16 cm	11 ml	9.5
1.00 mm	7.5 x 10 cm	6 ml	4.5
	16 x 10 cm	11 ml	9.5
	16 x 16 cm	16 ml	14.5
1.50 mm	7.5 x 10 cm	8 ml	6.5
	16 x 10 cm	15 ml	13.5
	16 x 16 cm	24 ml	22.5
<b>Spacer Thickness</b>	<b>16 x 16 cm Gel</b>	<b>16 x 10 cm Gel</b>	
0.75 mm		25 ml	15 ml
1.00 mm		30 ml	20 ml
1.50 mm		45 ml	26 ml

### **Sample Preparation**

1. It is important to optimize the PCR reaction to minimize unwanted products which may interfere with gel analysis. PCR products should be evaluated for purity by agarose gel electrophoresis before being loaded onto a denaturing acrylamide gel.
2. For a perpendicular denaturing gel, load about 1–3 µg of amplified DNA per well (usually 50% of a 100 µl PCR volume from a 100 ng DNA template). Both wild-type and mutant samples are mixed together and run on the same gel.
3. For a parallel denaturing gel, load 180–300 ng of amplified DNA per well (usually 5–10% of a 100 µl PCR volume from a 100 ng DNA template). A wild-type control should be run on every gel.
4. Add an equal volume of 2x gel loading dye to the sample.
5. Heteroduplexes can be generated during PCR by amplifying the mutant and wild-type samples in the same tube. If the samples are amplified in separate tubes, then heteroduplexes can be formed by mixing an equal amount of mutant and wild-type samples in one tube. Heat the tube at 95 °C for 5 minutes, then place at 65°C for 1 hour, and let slowly cool to room temperature.

## Temperature Controller

The temperature controller maintains the desired buffer temperature in the DCode system.

### Turning on the Controller

Turn the controller on by pressing the power button and wait for the controller to initialize. The controller will display the following screens in order:

- The program code
- The date code and serial code
- The hours used
- The temperature control screen (see Fig. 1).

The controller is now ready to be programmed.

### Setting the Set Temperature and Ramp Rate

1. From the temperature control screen, use the arrow keys to adjust the Set Temperature to your desired target temperature in °C (Fig. 1)
2. Use the  key to display the ramp control screen. (Fig. 2.)
3. From the ramp control screen, use the arrow keys to set the desired temperature Ramp Rate in °C per hour. Note that the maximum ramp rate for the DCode is 50°C /hr. If the target Ramp Rate is set using the controller to higher than 50°C /hr the maximum ramp rate of 50°C /hr will be used.

4. To toggle between the temperature control screen and the ramp control screen, or to review the set temperature and ramp rate, press the  key at any time

**Note:** Following programming by default the controller displays the Step Temperature rather than the Set Temperature (see Fig 1. below). The step temperature is the next temperature value the system will reach as it heats/cool to reach set temperature. To display the Set Temperature press the  key.

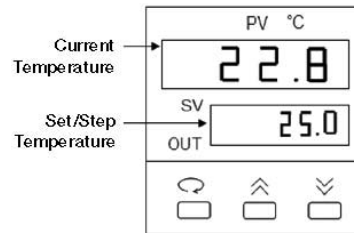

Fig. 1. Temperature Control Screen.

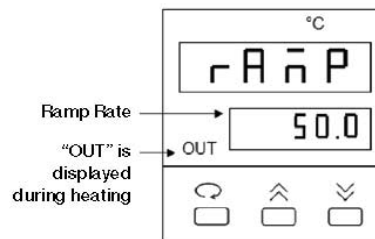

Fig. 2. Ramp Control Screen.

### Pre-heating the Running Buffer

1. Fill the electrophoresis tank with 7 L of 1x TAE running buffer.  
**Note:** It is recommended that the running buffer not be reused. Reusing the running buffer may affect the migration rate and band resolution.
2. Place the temperature control module on top of the electrophoresis tank. Attach the power cord to the temperature control module and turn the power, pump, and heater on. The clear loading lid should be on the temperature control module during preheating.
3. Set the temperature controller to the desired temperature. Set the temperature ramp rate to 200 °C/hr to allow the buffer to reach the desired temperature the quickest.
4. Preheat the buffer to the set temperature. It can take 1 to 1.5 hours for the system to heat the buffer up to the set temperature. Heating the buffer in a microwave helps reduce the preheating time.

### Assembling the Perpendicular Gradient Gel Sandwich

For perpendicular gel formats, 7.5 x 10 cm (dual) and 16 x 16 cm (single) gel sandwich sizes are recommended. These two different perpendicular gel formats consist of a set of spacers that provide casting at the side of the gel sandwich via the stopcock. To insure proper alignment, make sure all plates and spacers are clean and dry before assembly. Use caution when assembling the glass plate sandwiches. Wear gloves and eye protection at all times.

1. Assemble the gel sandwich on a clean surface. Lay the large rectangular plate down first, then place the left and right spacers of equal thickness along the short edges of the larger rectangular plate. To assemble perpendicular gradient gels, place the spacers so that the holes on the spacers are at the top of the plate with the grooved side of the spacer against the larger glass plate. When properly placed, the notched edges of the spacers will face each other.
2. Place a short glass plate on top of the spacers so that it is flush with the bottom edge of the long plate.
3. Loosen the single screw of each sandwich clamp by turning counterclockwise. Place each clamp by the appropriate side of the gel sandwich with the locating arrows facing up and toward the glass plates (Figure 4.5).

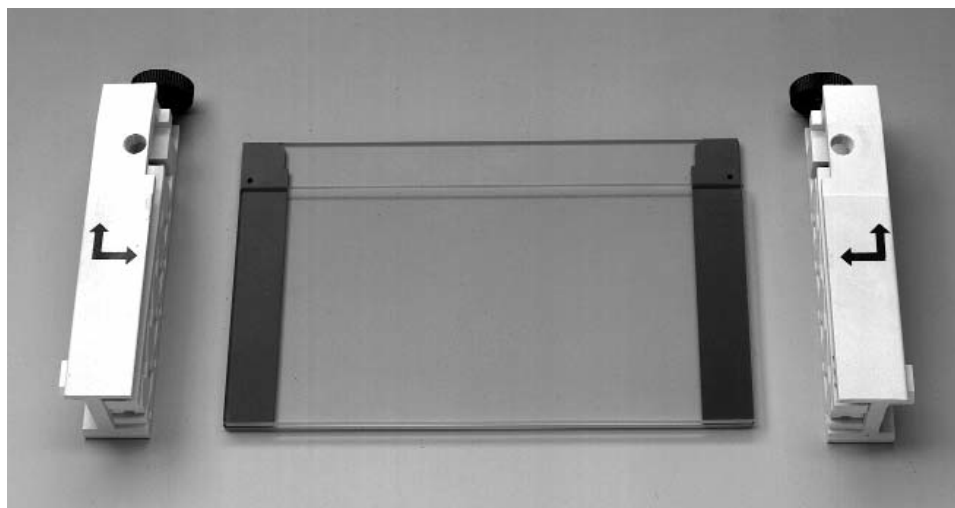

Fig. 4.5. Positioning glass plates, spacers, and clamps.

4. Grasp the gel sandwich firmly. Guide the left and right clamps onto the sandwich so that the long and short plates fit the appropriate notches in the clamp (Figure 4.6). Tighten the screws enough to hold the plates in place.

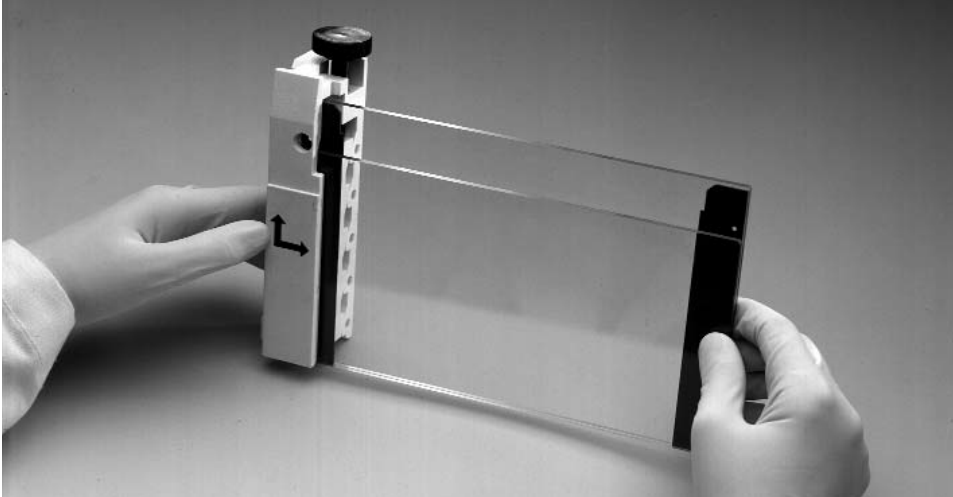

Fig. 4.6. Attaching the clamps to the glass plate assembly.

5. Place the sandwich assembly in the alignment slot (the slot without cams) of the casting stand with the short glass plate forward (Figure 4.7). Loosen the sandwich clamps and insert an alignment card to keep the spacers parallel to the clamps.

**Note:** Always use the alignment slot and alignment card to set the spacers in place. Failure to use these can result in gel leakage when casting, as well as buffer leakage during the run.

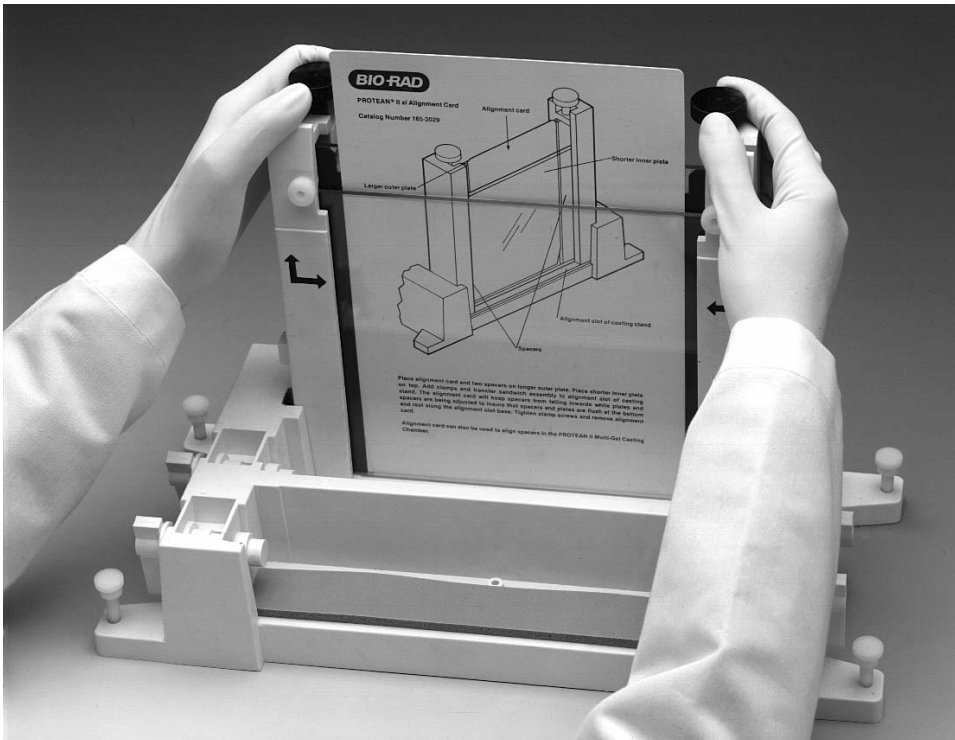

Fig. 4.7. Aligning spacers in the sandwich assembly.

6. Align the plates and spacers by simultaneously pushing inward on both clamps at the locating arrows while, at the same time, pushing down on the spacers with your thumbs. Tighten both clamps just enough to hold the sandwich in place. Pushing inward on both clamps at the locating arrows will insure that the spacers and glass plates are flush against the sides of the clamps (Figure 4.7).
7. Remove the alignment card. Then, remove the sandwich assembly from the casting stand and check that the plates and spacers are flush at the bottom. If they are not flush, realign the sandwich and spacers (Repeat steps 5–7).
8. When a good alignment and seal are obtained, tighten the clamp screws until it is finger-tight.
9. Place the proper comb in the sandwich and align it against the notches in the spacers. For the 7.5 x 10 cm perpendicular gradient gel, insert the middle spacer into the center of the sandwich until it fits into the middle notch on the comb. Straighten the spacer and the comb. The bottom of the middle spacer should also be flush against the glass plates (Figure 4.8).

**Note:** The proper comb for a 7.5 x 10 cm gel is the dual comb that requires a middle spacer to separate the two 7.5 x 10 cm gels, whereas the 16 x 16 cm gel comb is a single comb that does not require a middle spacer.

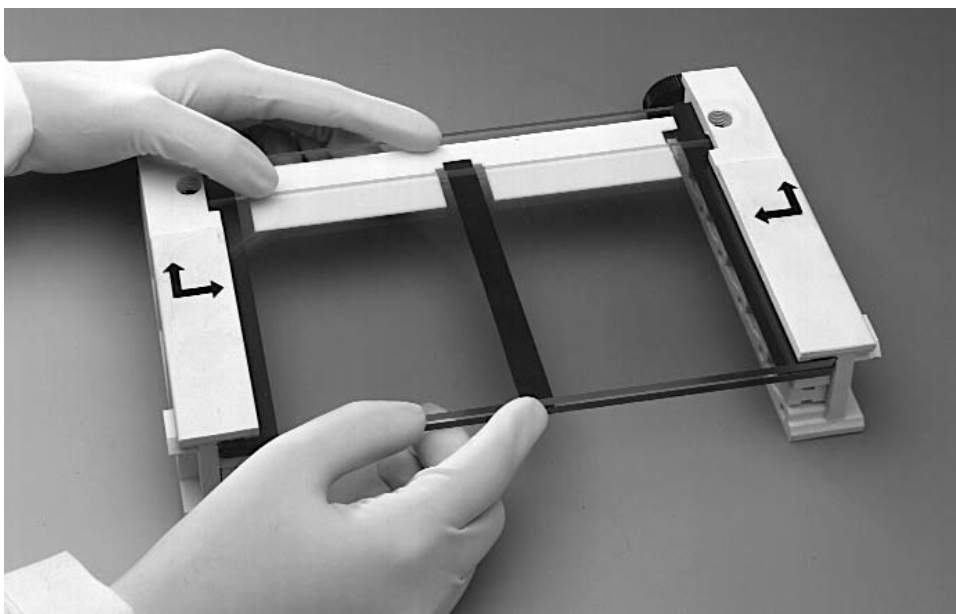

Fig. 4.8. Positioning the middle spacer in a 7.5 x 10 cm gel sandwich assembly.

10. Inspect the comb gasket to insure that the comb gasket is free of gel material. Remove any polymerized material in the comb gasket vent ports. The soft comb gasket should lay flat within the comb gasket holder.

**Note:** To remove the soft comb gasket from the holder, push the gasket away from the four holes in the holder. To replace the comb gasket, insert the gasket into the holder with the thick portion in first. Place one corner of the gasket against the top portion of the holder. With a flat spatula, guide the four tabs into the four holes. Carefully run the spatula across the gasket to completely set the gasket in place.



11. Stand the sandwich assembly upright on a flat surface. Loosen the comb gasket holder screws until the threads can no longer be seen. Mark an arrow on the middle of the screw head using a permanent marker (this will be the marker for adjusting the proper screw tension). With the comb gasket screws and the long plate facing you, slide the comb gasket holder down over the top of the assembled glass sandwich. When the comb gasket is properly placed, the angled cuts on the edges of the comb gasket will rest on the complementary angled cuts at the top of each spacer. Turn the screws until they just make contact with the glass plate, then twist the screws an additional 1/4 turn.
12. Before the screws can be completely tightened, the pressure clamp must be attached to the sandwich assembly. Loosen the pressure clamp screw. Mark an arrow on the middle of the screw head using a permanent marker (this will be the marker for adjusting the proper screw tension). Lay the pressure clamp on a flat surface so that the notched cut-out faces the ceiling and the pressure clamp screw points up and away from you.
13. Without touching the comb gasket holder, turn the assembled glass sandwich so that the comb gasket screws are facing down and the vent ports are facing up. Center the assembly over the pressure clamp and allow the assembly to rest on top of it. A properly placed pressure clamp will be situated on the middle of the sandwich with the notched cut-out against the bottom of the glass plate. Proper placement of the sandwich assembly in the pressure clamp will insure that equal force is applied to the comb gasket holder during the final tightening of the screws. Twist the pressure clamp screw until it makes contact with the comb gasket holder, then tighten the pressure clamp screw two additional turns (use the arrow to keep track of the turns).

**Note:** Check to insure that the bottom of the glass plates are still flush. If the plates are off-set, one or both of the sandwich clamps may not be tightened. Repeat steps 5–13.
14. Tighten the comb gasket screws an additional one turn. If it is tightened more, the glass plates may crack. For a proper seal, check to see that the notches on both the comb gasket and spacers are sealed against each other. It is important that the gasket is placed properly to prevent leakage while casting. Remove the pressure clamp.
15. Twist the injection port fitting into the holes on the sandwich clamps. Do not over-tighten; it will damage the O-ring and cause leakage. A snug fit is all that is needed to place the injection port against the glass plate assembly. Push a stopcock into each of the injection port fittings. Make sure that the fit is snug. A loose stopcock may cause leakage during casting.
16. Place the gray sponge onto the front casting slot. The camshafts on the casting stand should have the handles pointing up and pulled out. Place the sandwich on the sponge with the shorter plate facing forward. When the sandwich is placed correctly, press down on the sandwich and turn the handles of the camshaft down so that the cams lock the sandwich in place.
  - a. For a 7.5 x 10 cm dual gel sandwich, only half of the sandwich is cast at a time. Open the stopcock and unplug the vent port on the side of the sandwich where the gel is being cast. To prevent leakage the other half of the sandwich should have a closed stopcock and plugged vent port.
  - b. For a 16 x 16 cm gel sandwich, both vent ports should be plugged to prevent leakage during casting. The 16 x 16 cm spacers are one orientation only, thus the special casting groove is always on the right-hand side and the smaller, shorter groove on the left-hand side of the gel sandwich.
17. Tilt the gel sandwich assembly and casting stand using the tilt rod as a leg. Adjust the tilt level to the highest etched line on the rod (the one farthest from the black tilt-rod cap) for the 7.5 x 10 cm format and the lowest etched line on the rod for the 16 x 16 cm format.
18. Familiarize yourself with the Model 475 Gradient Delivery System before casting perpendicular gradient gels.

## Casting Perpendicular Denaturing Gradient Gels

1. One length of Tygon tubing is provided and should be cut into two 15.5 cm lengths and one 9 cm length. The longer pieces of Tygon tubing will be used to conduct the gel solution from the syringes into the Y-fitting. The short piece of Tygon tubing will conduct the gel solution from the Y-fitting to the gel sandwich. Connect one end of the 9 cm Tygon tubing to the Y-fitting and connect a luer coupling to the other end of the 9 cm tubing. Connect luer fittings onto the two long pieces of tubing. Connect the luer fittings to 10 ml or 30 ml syringes. Do not connect the long Tygon tubing to the Y-fitting at this time.
2. Label one of the syringes LO (for the low density solution) and one HI (for the high density solution). Attach a plunger cap onto each syringe plunger "head." Position the plunger "head" in the middle of the plunger cap and tighten enough to hold the plunger in place. Position the cap in the middle for proper alignment with the lever on the gradient delivery system. Slide each syringe into a syringe sleeve. Move the sleeve to the middle of the syringe, keeping the volume gradations visible. Make sure that the lever attachment screw is in the same plane as the flat or back side of the sleeve. This is very important for proper attachment of the syringe to the lever.

**Note:** Insure that the tubing is free of any gel material by pushing water through the tubing with the syringe. The tubing should be free of material before casting, remove any remaining water from the tubing.

3. Rotate the cam wheel counterclockwise to the vertical or start position. To set the desired delivery volume, loosen the volume adjustment screw. Place the volume setting indicator located on the syringe holder to the desired volume setting. Tighten the volume adjustment screw. For 7.5 x 10 cm gels (1 mm thick), set the volume setting indicator to 4.5. For 16 x 16 cm gels (1 mm thick), set the volume setting indicator to 14.5. Refer to Section 4.1.
4. From the stocks solutions, pipet out the desired amounts of the high and low density gel solutions into two disposable test tubes, Section 4.1.

**Optional:** To visually check the formation of the gradient, add 100  $\mu$ l of DCode dye solution per 5 ml high density solution.

**Note:** The gel solution volume should be greater than the amount set on the volume adjustment lever. For example, if the setting indicator is set at 4.5, the syringe should contain 5 ml of the gel solution. This extra solution is needed to push the correct amount into the gel sandwich.

**The steps below are time-sensitive (about 7–10 minutes). Insure that steps 1 through 4 are done before proceeding further. Be thoroughly familiar with the following steps before casting the gel.**

5. Add a final concentration of 0.09% (v/v) each of ammonium persulfate and TEMED solutions. The 0.09% (v/v) concentrations allow about 5–7 minutes to finish casting the gel before polymerization. Cap and mix by inverting several times. With the syringe connected to the tubing, withdraw all of the high density solution into the HI syringe. Do the same for the low density solution into the LO syringe.

**Note:** Acrylamide is a very hazardous substance. Use caution: wear gloves and eye protection at all times. Avoid skin contact.

6. Carefully remove air bubbles from the LO syringe by turning it upside down (plunger cap towards the bench) and gently tapping. Push the gel solution to the end of the tubing. Do not push it out of the tubing as loss of gel solution will disturb the volume required to cast the desired gel.

7. Place the LO syringe into the gradient delivery system syringe holder (LO density side) by holding the syringe by the plunger and inserting the lever attachment screw into the lever groove. Do not handle the syringe. It will dispense the gel solution out of the syringe. Casting a perpendicular gel is referred to as a **bottom filling method**, so place the LO syringe on the correct side of the gradient system.
8. Carefully remove the air bubbles from the HI syringe by turning it upside down (plunger cap towards the bench) and gently tapping. Push the gel solution to the end of the tubing. Do not push it out of the tubing as loss of gel solution will disturb the volume required to cast the desired gel.
9. Place the HI syringe into the gradient delivery system syringe holder (HI density side) by holding the syringe by the plunger and inserting the lever attachment screw into the lever groove. Do not handle the syringe. It will dispense the gel solution out of the syringe.
10. Slide the tubing from the low density syringe to one end of the Y-fitting. Do the same for the high density syringe.
11. Connect the 9 cm tubing with the luer coupling on the sandwich assembly stopcock. Insure that the stopcock is open and that the vent port is unplugged for the half of the sandwich being cast.
 

**Note:** For a 16 x 16 cm single gel, both stopcocks are open during casting. After casting, both stopcocks are closed.
12. Rotate the cam wheel slowly and steadily to deliver the gel solution. It is important to cast the gel solution at a steady pace to avoid disturbances between gel solutions within the sandwich.

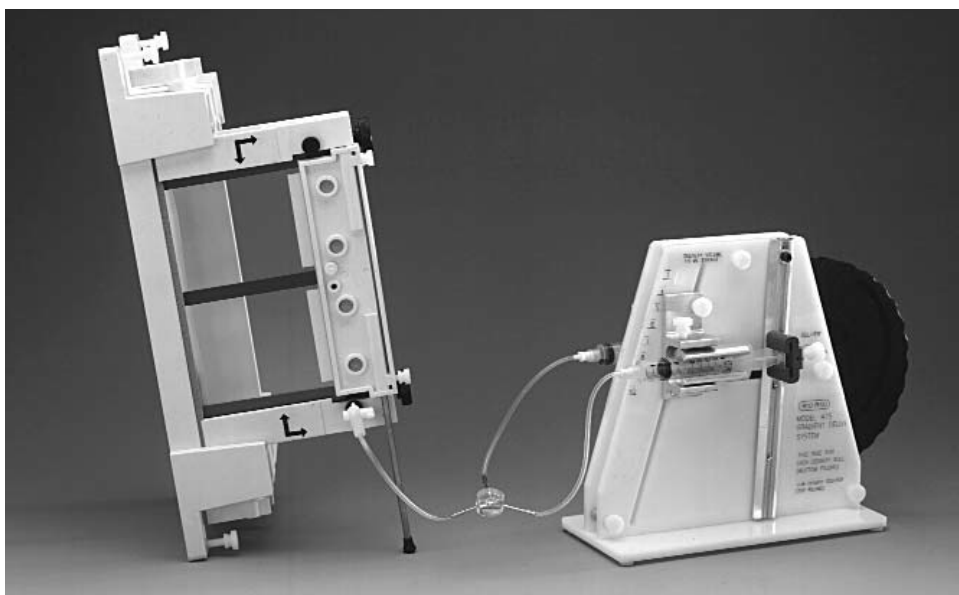

**Fig. 4.9.** Casting a perpendicular gradient gel using the Model 475 gradient delivery system.

13. Plug the vent port and close the stopcock on the gel sandwich when the cam wheel has reached the stop position. Carefully level the gel sandwich by adjusting the gasket tilt rod. Be sure to loosen the tilt rod screw and not the sandwich clamp screw.

**Note:** For a properly cast perpendicular gradient gel it is extremely important to level the sandwich assembly after casting.

14. Immediately remove the tubing from the sandwich assembly stopcock. Place the tubing into a beaker of water and reverse the cam on the Gradient Delivery System. This will rinse the tubing and Y-fitting. Remove both syringes from the syringe holder on the gradient delivery system. Detach the syringe tubing from the Y-fitting. Run or push water out through the syringe, tubing and Y-fitting several times to get rid of any residual gel solution. It is extremely important that this is done quickly after casting to avoid any gel polymerization.
15. Let the gel polymerize for about 60 minutes. To cast the other half of the 7.5 x 10 cm gel format, remove the gasket tilt rod and place it on the other side of the comb gasket. Repeat steps 4 through 15.

**Note:** If casting a single 7.5 x 10 cm gel, let the gel solution polymerize for 60 minutes. Carefully remove the comb gasket; leave the comb in place and pipette (on an opening near the spacer) a 10 ml gel solution plus initiators in the uncast half of the sandwich to create a dam.

16. After polymerization, remove the comb by pulling it straight up slowly and gently.
17. Continue with Section 8 for electrophoresis.

### Assembling the Parallel Gradient Gel Sandwich

For parallel gel formats, a 16 x 16 cm gel sandwich size is recommended. The parallel gel format does not require special casting grooves in the spacers, so the straight edge portion (ungrooved side) of the spacers is used. To insure proper alignment, make sure all plates and spacers are clean and dry before assembly. Use caution when assembling the glass plate sandwiches. Wear gloves and eye protection at all times.

1. Assemble the gel sandwich on a clean surface. Lay the large rectangular plate down first, then place the left and right spacers of equal thickness along the short edges of the larger rectangular plate. To assemble parallel gradient gels, place the spacers so that the grooved opening of the spacers face the sandwich clamps. When properly placed, the grooved side of the spacers and the notches will face the sandwich clamps, and the hole is located near the top of the plates.
2. Place the short glass plate on top of the spacers so that it is flush with the bottom edge of the long plate.
3. Loosen the single screw of each sandwich clamp by turning each screw counterclockwise. Place each clamp by the appropriate side of the gel sandwich with the locating arrows facing up and toward the glass plates (Figure 4.10).



Fig. 4.10. Positioning glass plates, spacers, and clamps.

4. Grasp the gel sandwich firmly. Guide the left and right clamps onto the sandwich so that the long and short plates fit the appropriate notches in the clamp. Tighten the screws enough to hold the plates in place (Figure 4.11).

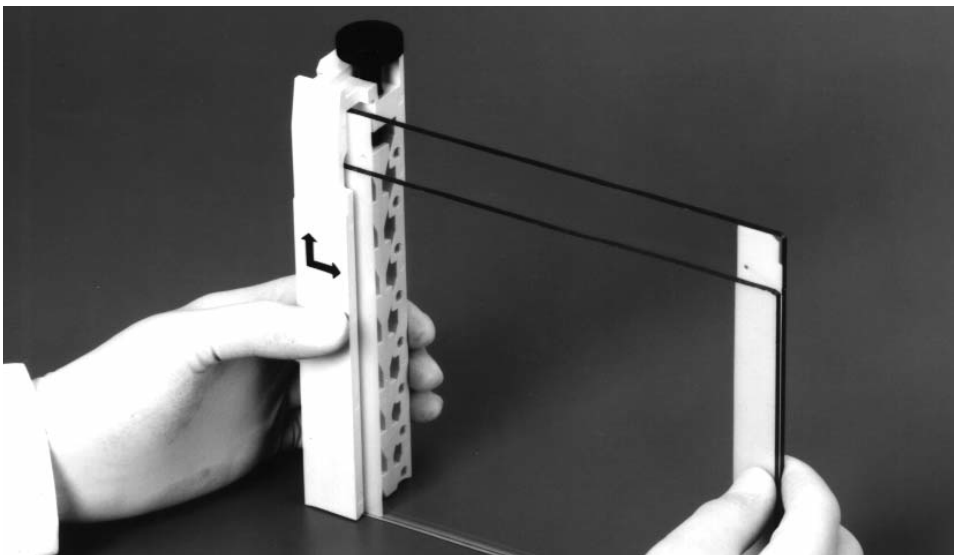

Fig. 4.11. Attaching the clamps to the glass plate assembly.

5. Place the sandwich assembly in the alignment slot (the slot without cams) of the casting stand with the short glass plate forward (Figure 4.12). Loosen the sandwich clamps and insert an alignment card to keep the spacers parallel to the clamps.

**Note:** Always use the alignment slot and alignment card to set the spacers in place. Failure to use these can result in gel leakage while casting, as well as buffer leakage during the run.

6. Align the plates and spacers by simultaneously pushing inward on both clamps at the locating arrows while at the same time pushing down on the spacers with your thumbs; tighten both clamps just enough to hold the sandwich in place. Pushing inward on both clamps at the locating arrows will insure that the spacers and glass plates are flush against the sides of the clamps (Figure 4.12).

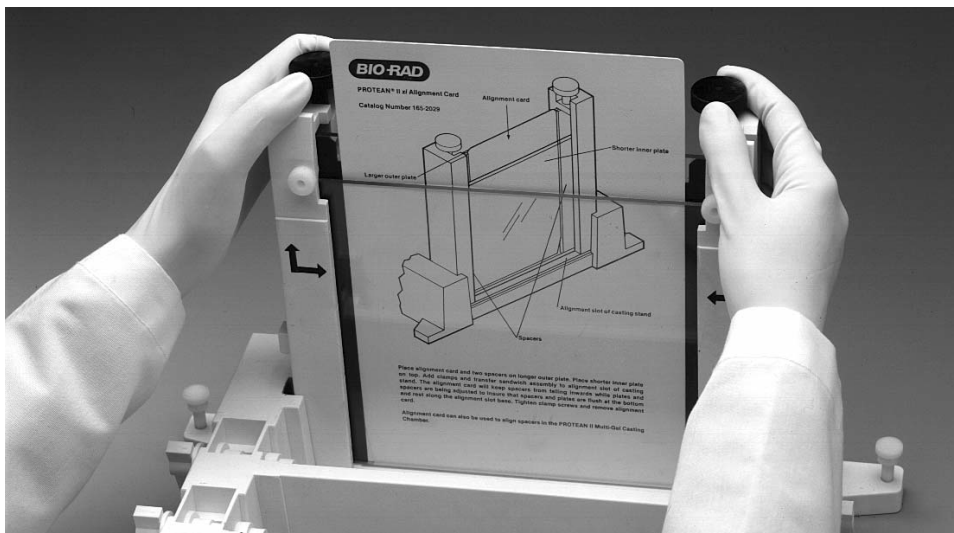

Fig. 4.12. Aligning spacers in the sandwich assembly.

7. Remove the alignment card. Remove the sandwich assembly from the casting stand and check that the plates and spacers are flush at the bottom. If the spacers and glass plates are not flush, realign the sandwich and spacers to obtain a good seal (Repeat steps 5–7).
8. When a good alignment and seal are obtained, tighten the clamp screws until it is finger-tight.

### **Casting Parallel Denaturing Gradient Gels**

1. Place the gray sponge onto the front casting slot. The camshafts on the casting stand should have the handles pointing up and pulled out. Place the sandwich assembly on the sponge with the shorter plate facing you. When the sandwich is placed correctly, press down on the sandwich and turn the handles of the camshaft down so that the cams lock the sandwich in place. Position the gel sandwich assembly by standing it upright.
2. One length of Tygon tubing is provided and should be cut into two 15.5 cm lengths and one 9 cm length. The longer pieces of Tygon tubing will be used to conduct the gel solution from the syringes into the Y-fitting. The short piece of Tygon tubing will conduct the gel solution from the Y-fitting to the gel sandwich. Connect one end of the 9 cm Tygon tubing to the Y-fitting and connect a luer coupling to the other end of the 9 cm tubing. Connect luer fittings onto the two long pieces of tubing. Connect the luer fittings to 30 ml syringes. Do not connect the long Tygon tubing to the Y-fitting at this time.
3. Label one of the syringes LO (for the low density solution) and one HI (for the high density solution). Attach a plunger cap onto each syringe plunger "head." Position the plunger "head" in the middle of the plunger cap and tighten enough to hold the plunger in place. Position the cap in the middle for proper alignment with the lever on the gradient delivery system. Slide each syringe into a syringe sleeve. Move the sleeve to the middle of the syringe, keeping the volume gradations visible. Make sure that the lever attachment screw is in the same plane as the flat or back side of the sleeve. This is very important for proper attachment of the syringe to the lever.

**Note:** Insure that the tubing is free of any gel material by pushing water through the tubing with the syringe. The tubing should be free of material before casting, remove any remaining water from the tubing.

4. Rotate the cam wheel counterclockwise to the vertical or start position. To set the desired delivery volume, loosen the volume adjustment screw. Place the volume setting indicator located on the syringe holder to the desired volume setting. Tighten the volume adjustment screw. For 16 x 16 cm gels (1 mm thick), set the volume setting indicator to 14.5. Refer to Section 4.1.
5. From the stocks solutions, pipet out the desired amounts of the high and low density gel solutions into two disposable test tubes (refer to the Section 4.1).

**Optional:** To visually check the formation of the gradient, add 100  $\mu$ l of DCode dye solution per 5 ml high density solution.

**The steps below are time-sensitive (about 7–10 minutes). Insure that steps 2 through 5 are done before proceeding further. Be thoroughly familiar with the following steps before casting the gel.**

6. Add the final concentration of 0.09% (v/v) each of ammonium persulfate and TEMED solutions. The 0.09% (v/v) concentrations allow about 5–7 minutes to finish casting the gel before polymerization. Cap and mix by inverting several times. With the syringe connected to the tubing, withdraw all of the high density solution into the HI syringe. Do the same for the low density solution into the LO syringe.

**Note:** Acrylamide is a very hazardous substance. Use caution: wear gloves and eye protection at all times. Avoid skin contact.

7. Carefully remove air bubbles from the LO syringe by turning the syringe upside down (plunger cap towards the bench) and gently tapping the syringe. Push the gel solution to the end of the tubing. Do not push it out of the tubing as loss of solution will disturb the volume required to cast the desired gel.
 

**Note:** The gel solution volume should be greater than the amount set on the volume adjustment lever. For example, if the indicator setting is set at 14.5, the syringe should contain 15 ml of solution. This extra solution is needed to deliver the correct amount for casting.
8. Place the LO syringe into the gradient delivery system syringe holder (LO density side) by holding the syringe by the plunger and inserting the lever attachment screw into the lever groove. Do not handle the syringe. It will dispense the gel solution out of the syringe. Casting a parallel gel is referred to as a **top filling method**, so place the LO syringe on the correct side of the gradient system.
9. Carefully remove the air bubbles from the HI syringe by turning the syringe upside down (plunger cap towards the bench) and gently tapping the syringe. Push the solution to the end of the tubing. Do not push it out of the tubing as loss of solution will disturb the volume required to cast the desired gel.
10. Place the HI syringe into the gradient delivery system syringe holder (HI density side) by holding the syringe by the plunger and inserting the lever attachment screw into the lever. Do not handle the syringe. It will dispense the gel solution out of the syringe.
11. Slide the tubing from the low density syringe over one end on the Y-fitting. Do the same for the high density syringe.
12. Attach a 19 gauge needle to the coupling. Hold the beveled side of the needle at the top-center of the gel sandwich and cast (Figure 4.13). For convenience, the needle can be taped in place.

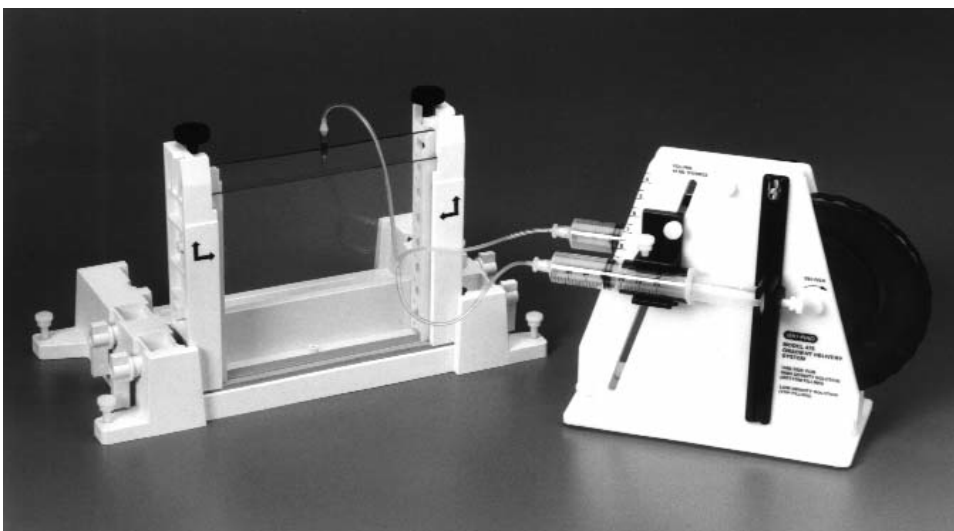

Fig. 4.13. Casting a parallel gradient gel.

13. Rotate the cam wheel slowly and steadily to deliver the gel solution. It is important to cast the gel solution at a steady pace to avoid any disturbances between the gel solutions within the gel sandwich.
14. Carefully insert the comb to the desired well depth and straighten. Let the gel polymerize for about 60 minutes.

15. Place the tubing and needle into a beaker of water and reverse the cam on the Gradient Delivery System. This will rinse the tubing and Y-fitting. Remove both syringes from the syringe holder on the gradient delivery system. Detach the syringe tubing from the Y-fitting. Run or push water out through the syringe, tubing, and Y-fitting several times to get rid of any residual gel solution. It is very important that this is done quickly after casting to avoid premature gel polymerization.
16. After polymerization, remove the comb by pulling it straight up slowly and gently.
17. Continue with Section 8 for electrophoresis.

## 4.2 Introduction to Constant Denaturing Gel Electrophoresis (CDGE)

Constant Denaturing Gel Electrophoresis is a modification of DGGE. In CDGE, the denaturant concentration that gives optimal resolution from a parallel or perpendicular DGGE gel is held constant.<sup>13</sup> The optimal concentration of denaturant to use for a CDGE is determined from the maximum split between wild-type and mutant DNA, as seen in the perpendicular or parallel denaturing gel. To calculate the concentration of denaturant for a CDGE gel, first place a fluorescent ruler along the axis of the denaturant gradient when taking a photograph. Then, determine the distance along the gradient where the maximum split is seen between bands. In the example in Figure 4.14, the distance is 5 cm. Divide this distance by the length of the gel and multiply by the denaturant range. For example,  $(5-8) \times 50\% = 31\%$ . Add this number to the starting denaturant concentration to determine the optimum concentration to use for CDGE ( $20\% + 31\% = 51\%$ ). The same calculation can be applied to samples that are run on a parallel DGGE gel.

After a mutation has been identified by previous DGGE gels, a CDGE gel can be used to rapidly screen samples for the presence of a mutation. With no gradient required, rapid, high-throughput screening is possible. As in DGGE, the formation of heteroduplex analysis can help in resolving wild-type and mutated fragments when it is not possible to detect a mutation by running homoduplex fragments. An example of a CDGE gel is shown in Figure 4.15.

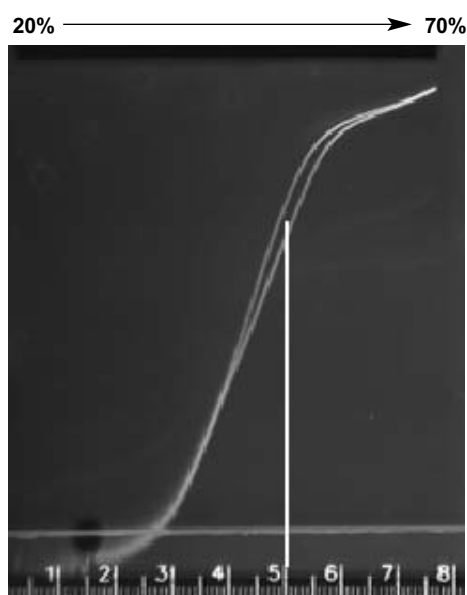

**Fig. 4.14. Example of perpendicular DGGE gel used for determining the optimum denaturant concentration used in a CDGE gel.** The distance along the gradient where the maximum split seen between samples is 5 cm. The denaturant concentration of the gradient at this distance is 51%. Therefore, the CDGE gel should use a denaturant concentration of 51%.



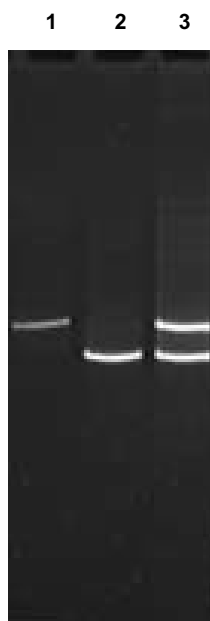

**Fig. 4.15. Constant denaturing gel. Amplified mutant and wild-type alleles of exon 8 from the p53 gene.** Separation by CDGE run at 130 V for 2.5 hours on a 10% acrylamide gel in 51% denaturant at 56 °C. Lane 1, mutant allele; lane 2, wild-type allele; lane 3, mutant and wild-type allele.

### Reagent Preparation

The concentration of denaturant is determined from a perpendicular or parallel DGGE gel. The concentration of acrylamide may vary, depending on the size of the fragment that is being analyzed. Both 0% and 100% denaturant should be made as stock solutions. A 100% denaturant is a mixture of 7 M urea and 40% deionized formamide. Reagents for casting and running CDGE gels are included in the DCode electrophoresis reagent kit for DGGE/CDGE, catalog number 170-9032.

For different percent crosslinking, use the equation below to determine the amount of Bis to add. The example stock solution below is for an acrylamide/bis ratio of 37.5:1.

#### 40% Acrylamide/Bis (37.5:1)

Reagent	Amount
Acrylamide	38.93 g
Bis-acrylamide	1.07 g
dH <sub>2</sub> O	to 100.0 ml

Filter through a 0.45 μ filter and store at 4°C.

For different percent crosslinking, use the equation below to determine the amount of Bis to add. The example stock solution is for an acrylamide/bis ratio of 37.5:1.

Polyacrylamide gels are described by reference to two characteristics:

- 1) Total monomer concentration (%T)
- 2) Crosslinking monomer concentration (%C)

$$\%T = \frac{\text{gm acrylamide} + \text{g bis-acrylamide}}{\text{total volume}} \times 100$$

$$\%C = \frac{\text{gm bis-acrylamide}}{\text{gm acrylamide} + \text{g bis-acrylamide}} \times 100$$

**50x TAE Buffer**

Reagent	Amount	Final Concentration
Tris base	242.0 g	2 M
Acetic acid, glacial	57.1 ml	1 M
0.5 M EDTA, pH 8.0	100.0 ml	50 mM
dH <sub>2</sub> O	to 1,000.0 ml	

Mix. Autoclave for 20–30 minutes. Store at room temperature.

**0% Denaturing**

Solution	6% Gel	8% Gel	10% Gel	12% Gel
40% Acrylamide/Bis	15 ml	20 ml	25 ml	30 ml
50x TAE buffer	2 ml	2 ml	2 ml	2 ml
dH <sub>2</sub> O	83 ml	78 ml	73 ml	68 ml
Total volume	100 ml	100 ml	100 ml	100 ml

Degas for about 10–15 minutes. Store at 4°C in a brown bottle for approximately 1 month.

**100% Denaturing**

Solution	6% Gel	8% Gel	10% Gel	12% Gel
40% Acrylamide/Bis	15 ml	20 ml	25 ml	30 ml
50x TAE buffer	2 ml	2 ml	2 ml	2 ml
Formamide (deionized)	40 ml	40 ml	40 ml	40 ml
Urea	42 g	42 g	42 g	42 g
dH <sub>2</sub> O	to 100 ml	to 100 ml	to 100 ml	to 100 ml

Degas for about 10–15 minutes. Store at 4°C in a brown bottle for approximately 1 month. A 100% denaturant solution requires re-dissolving after storage. Place the bottle in a warm bath and stir for faster results.

To cast constant denaturing gradient gels, use the formula below to determine the volume of 0% and 100% denaturing solutions needed to achieve the desired denaturant concentration.

1. (% desired denaturant) (total gel volume needed) = ml of 100% denaturant solution
2. (total gel volume needed) - (ml of 100% denaturant) = ml of 0% denaturant solution

**Example:** To cast a 52% constant denaturing gel, use 30 ml total volume for a 16 x 16 cm gel with a 1.0 mm spacer.

1. (0.52)(30 ml) = 15.6 ml of 100% denaturing solution needed
2. (30 ml) - (15.6 ml) = 14.4 ml of 0% denaturing solution needed

The table below provides the percentage acrylamide/bis needed for a particular size range.

**Gel Percentage Base Pair Separation**

6%	300–1,000 bp
8%	200–400 bp
10%	100–300 bp

**10% Ammonium Persulfate**

Reagent	Amount
Ammonium persulfate	0.1 g
dH <sub>2</sub> O	1.0 ml

Store at –20°C for about a week.

### DCode Dye Solution

#### Reagent

#### AmountFinal Concentration

Bromophenol blue	0.05 g	0.5%
Xylene cyanol	0.05 g	0.5%
1x TAE buffer	10.0 ml	1x

Store at room temperature.

### 2x Gel Loading Dye

#### Reagent

#### AmountFinal Concentration

2% Bromophenol blue	0.25 ml	0.05%
2% Xylene cyanol	0.25 ml	0.05%
100% Glycerol	7.0 ml	70%
dH <sub>2</sub> O	2.5 ml	
Total volume	10.0 ml	

Store at room temperature.

### 1x TAE Running Buffer

#### Reagent

#### Amount

50x TAE buffer	140 ml
dH <sub>2</sub> O	6,860 ml
Total volume	7,000 ml

### Gel Volumes

The table below provides the required volume per gel size and spacer thickness.

Spacer Thickness	16 x 16 cm Gel	16 x 10 cm Gel
0.75 mm	25 ml	15 ml
1.00 mm	30 ml	20 ml
1.50 mm	45 ml	26 ml

### Sample Preparation

1. It is important to optimize the PCR reaction to minimize unwanted products which may interfere with gel analysis. The PCR products should be evaluated for purity by agarose gel electrophoresis before being loaded onto a denaturing acrylamide gel.
2. For a constant denaturing gel, load about 180–300 ng of amplified DNA per well (usually 5–10% of a 100 µl PCR volume from a 100 ng DNA template). A wild-type control should be run on every gel.
3. Add an equal volume of 2x gel loading dye to the sample.
4. Heteroduplexes can be generated during PCR by amplifying the mutant and wild-type samples in the same tube. If the samples are amplified in separate tubes, then heteroduplexes can be formed by mixing an equal amount of mutant and wild-type samples in one tube. Heat the tube at 95°C for 5 minutes, then place at 65°C for 1 hour, and let slowly cool to room temperature.

## Temperature Controller

The temperature controller maintains the desired buffer temperature in the DCode system.

### Turning on the Controller

Turn the controller on by pressing the power button and wait for the controller to initialize. The controller will display the following screens in order:

- The program code
- The date code and serial code
- The hours used
- The temperature control screen (see Fig. 1).

The controller is now ready to be programmed.

### Setting the Set Temperature and Ramp Rate

1. From the temperature control screen, use the arrow keys to adjust the Set Temperature to your desired target temperature in °C (Fig. 1)
2. Use the ↻ key to display the ramp control screen. (Fig. 2.)
3. From the ramp control screen, use the arrow keys to set the desired temperature Ramp Rate in °C per hour. Note that the maximum ramp rate for the DCode is 50°C /hr. If the target Ramp Rate is set using the controller to higher than 50°C /hr the maximum ramp rate of 50°C /hr will be used.

4. To toggle between the temperature control screen and the ramp control screen, or to review the set temperature and ramp rate, press the ↻ key at any time

**Note:** Following programming by default the controller displays the Step Temperature rather than the Set Temperature (see Fig 1. below). The step temperature is the next temperature value the system will reach as it heats/cool to reach set temperature. To display the Set Temperature press the ↻ key.

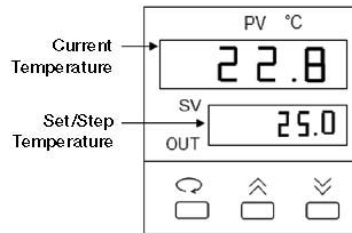

Fig. 1. Temperature Control Screen.

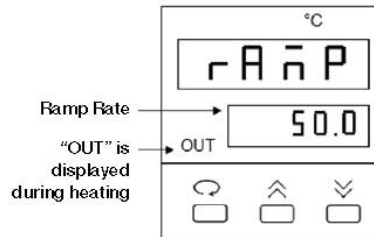

Fig. 2. Ramp Control Screen.

### **Pre-heating the Running Buffer**

1. Fill the electrophoresis tank to the "Fill" line with 7 L of 1x TAE buffer.

**Note:** It is recommended that the running buffer not be reused. Reusing the running buffer may affect the migration rate and band resolution.

2. Place the temperature control module on top of the chamber. Attach the power cord to the temperature control module and turn the power and heater switch on. The clear loading lid should be on the temperature control module during preheating.
3. Set the temperature to the desired temperature. Set the temperature ramp rate to 200°C/hr. to allow the buffer to reach the desired temperature the quickest.
4. Preheat the buffer to the set temperature. It can take 1 to 1.5 hours for the system to heat the buffer up to the set temperature. Heating the buffer in a microwave helps reduce the preheating time.

### **Assembling the CDGE Gel Sandwich**

For constant denaturing gel formats, a 16 x 16 cm gel sandwich is recommended. To insure proper alignment, make sure all plates and spacers are clean and dry before assembly. Use caution when assembling the glass plate sandwiches. Wear gloves and eye protection at all times.

1. Assemble the gel sandwich on a clean surface. Lay the large rectangular plate down first, then place the left and right spacers of equal thickness along the short edges of the larger rectangular plate.
2. Place a short glass plate on top of the spacers so that it is flush with the bottom edge of the long plate.
3. Loosen the single screw of each sandwich clamp by turning it counterclockwise. Place each clamp by the appropriate side of the gel sandwich with the locating arrows facing up and toward the glass plates (Figure 4.17).

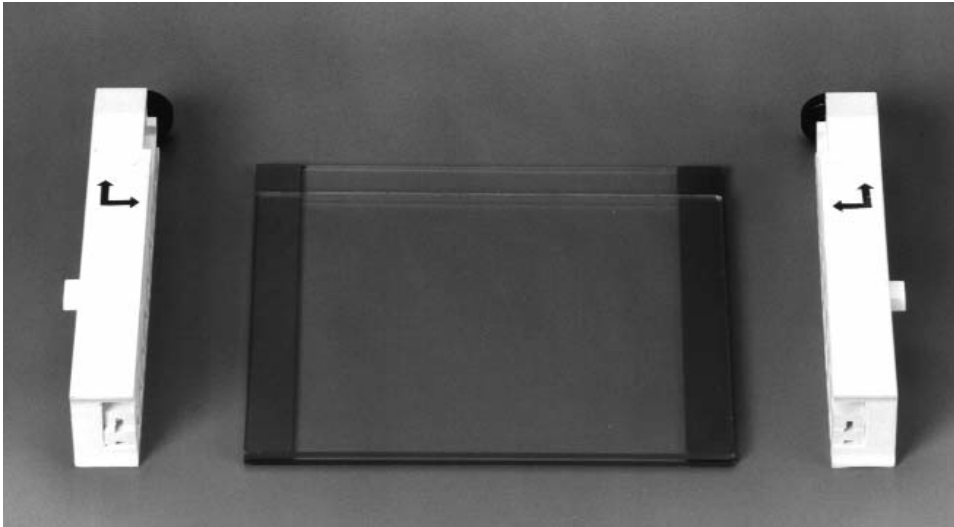

Fig. 4.17. Positioning glass plates, spacers, and clamps.

4. Grasp the gel sandwich firmly. Guide the left and right clamps onto the sandwich so that the long and short plates fit the appropriate notches in the clamp (Figure 4.18). Tighten the screws enough to hold the plates in place.

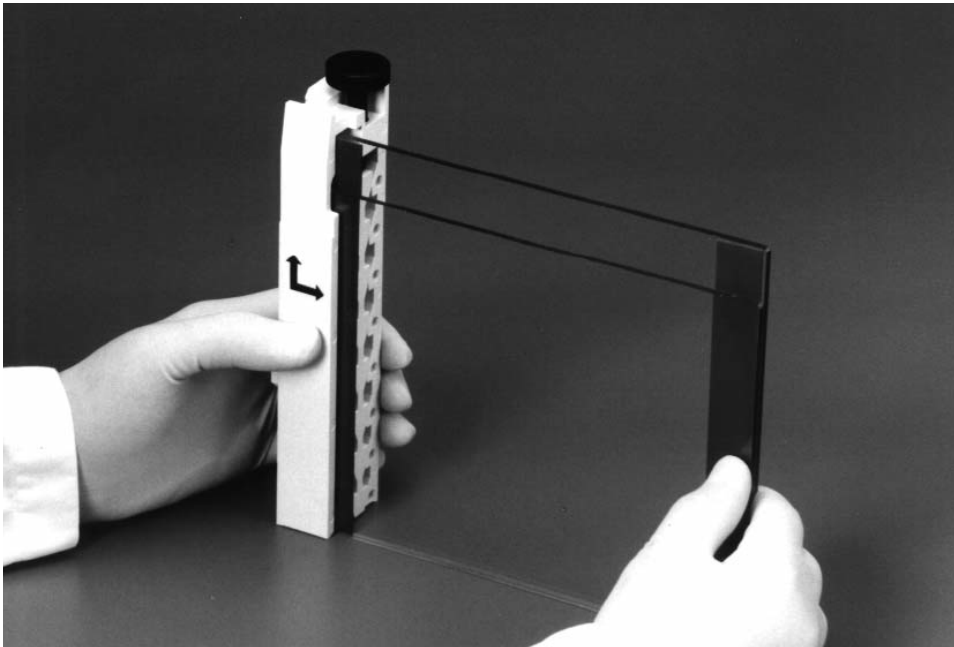
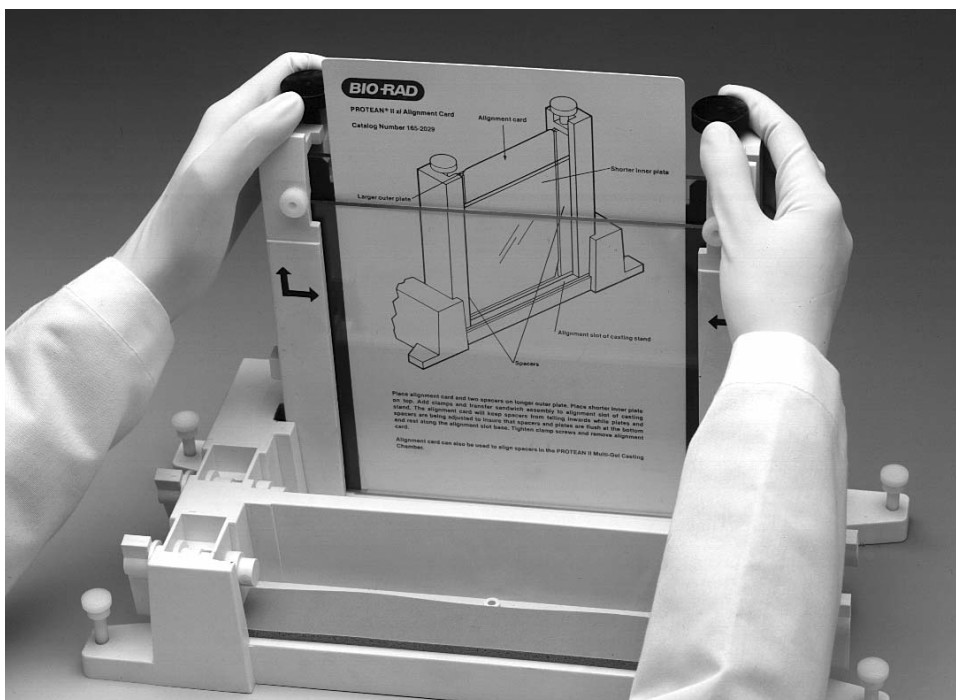

Fig. 4.18. Attaching the clamps to the glass plate assembly.

5. Place the sandwich assembly in the alignment slot (the slot without cams) of the casting stand with the short glass plate forward (Figure 4.19). Loosen the sandwich clamps and insert an alignment card to keep the spacers parallel to the clamps.

**Note:** Always use the alignment slot and alignment card to set the spacers in place. Failure to use these can result in gel leakage when casting, as well as buffer leakage during the run.

- Align the plates and spacers by simultaneously pushing inward on both clamps at the locating arrows while pushing down on the spacers with your thumbs. Tighten both clamps just enough to hold the sandwich in place. Pushing inward on both clamps at the locating arrows will insure that the spacers and glass plates are flush against the sides of the clamps (Figure 4.19).



**Fig. 4.19. Aligning spacers in the sandwich assembly.**

- Remove the alignment card. Remove the sandwich assembly from the casting stand and check that the plates and spacers are flush at the bottom. If they are not flush, realign the sandwich and spacers for a good seal (Repeat steps 5–7).
- When a good alignment and seal are obtained, tighten the clamp screws until it is finger-tight.

### **Casting CDGE Gels**

- Place the gray sponge onto the front casting slot. The camshafts on the casting stand should have the handles pointing up and pulled out. Place the sandwich assembly (16 x 16 cm) on the sponge with the shorter plate facing forward. When the sandwich is placed correctly, press down on it and turn the handles of the camshaft down so that the cams lock the sandwich in place.
- Into a 50 ml tube, add the required amounts of low density and high density solutions required for the desired denaturant percentage (see CDGE calculation, Section 4.2). Add a final concentration of 0.09% (v/v) each of ammonium persulfate and TEMED solutions. Cap the tube and mix.
- Insert a comb in the gel sandwich and tilt it so the teeth are at a slight angle. This will prevent air from being trapped under the comb teeth when pouring the gel solution (Figure 4.20).

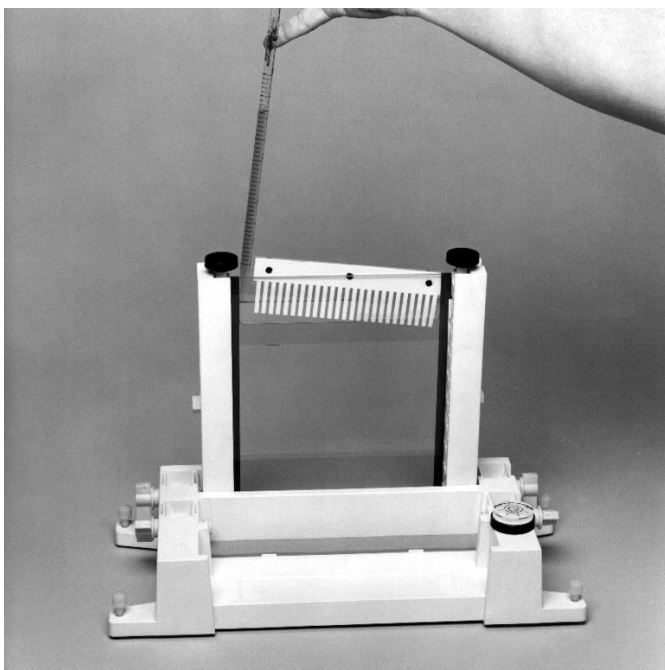

Fig. 4.20. Pouring a CDGE gel.

4. Pour or pipette the gel solution into the sandwich until the gel solution covers the wells of the comb. Straighten the comb to the desired well depth. Add more gel solution if needed.
5. Allow the gel to polymerize for about 60 minutes. After polymerization, remove the comb by pulling it straight up slowly and gently.
6. Continue with Section 8 for electrophoresis.

### 4.3 Introduction to Temporal Temperature Gradient Gel Electrophoresis (TTGE)

Temporal Temperature Gradient Gel Electrophoresis<sup>14,15</sup> (TTGE) exploits the principle on which DGGE is based, without requiring a chemical denaturing gradient. Amplified mutant and wild-type DNA from the gene of interest is loaded onto a polyacrylamide gel containing a constant concentration of urea. During electrophoresis, the temperature is increased gradually and uniformly. The result is a linear temperature gradient over the length of the electrophoresis run. Thus, a denaturing environment is formed by the constant concentration of urea in the gel in combination with the temporal temperature gradient. With no chemical gradient required, rapid, high-throughput screening is possible.

The DCode system allows precise control of the temperature ramp rate measured in °C per hour. Control over the temperature range and ramp rate allows optimum denaturing conditions. An example of a TTGE gel is shown in Figure 4.21.



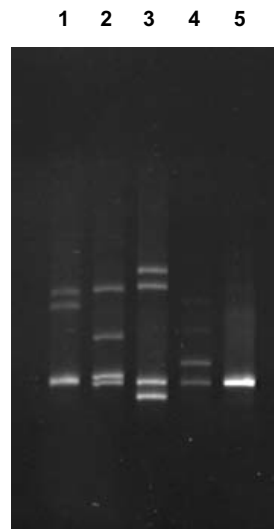

**Fig. 4.21. Temporal temperature gradient gel. Amplified mutant and wild-type alleles of exon 7 from the cystic fibrosis gene.** Separation by TTGE run at 130 V for 5 hours in 1.25x TAE buffer on a 6 M urea/6% acrylamide gel (37.5:1) using a temperature range of 50–60 °C and a ramp rate of 2 °C/hr. Lane 1, mutant allele (1154 insTC); lane 2, mutant allele (G330X); lane 3, mutant allele (deltaF311); lane 4, mutant allele (R334W); and lane 5, wild-type allele. (Samples courtesy of L. Silverman, Division of Molecular Pathology, University of North Carolina School of Medicine)

### Calculating the Run Parameters

To determine the temperature range to use with TTGE, a melting profile of the DNA sequence should be generated using a DNA melting software program, such as Bio-Rad's MacMelt software. As in DGGE, the addition of a 30–40 base pair GC clamp should be added to one of the PCR primers to insure that the region screened is in the lowest melting domain. The temperature range for the gradient can be calculated from the melting profile graph by first determining the lowest and highest non-GC clamp melting temperature of the DNA sequence (See example in Figure 4.22). From the calculated low and high temperatures, the theoretical melting temperatures can be lowered by adding urea to the gel. A denaturing urea gel will lower the theoretical melting temperature of DNA by 2°C for every mole of urea.<sup>32, 33</sup> In Figure 4.22, the theoretical melting temperature range on the DNA sequence of interest is approximately 68 to 82 °C. Therefore, the temperature range should be 54–68°C when using a 7 M urea gel. TTGE gels typically use 6 M of urea, but for sequences that generate melt profiles that require buffer temperature greater than 70°C, higher concentrations of urea should be used. Adding 1–2°C to the final temperature may help to improve the resolution of some mutations. The typical temperature range for TTGE gels are between 40 and 70°C.

Temperature ramp rates of 1–3°C/hr generally give the best resolution between mutant and wild-type samples. Slower ramp rates are best, but to reduce run times for routine screening, ramp rates can be increased empirically. The temperature ramp rate can be determined if the desired run time or temperature range is known. The ramp rate is calculated by subtracting the final temperature from the initial temperature and dividing by the desired run time. In Figure 4.22, if the run time is 4 hours, the ramp rate will be 3°C/hr  $([68-54^{\circ}] \div 4 \text{ hr} = 3.5 \text{ }^{\circ}\text{C/hr})$ . A desired run time is calculated by subtracting the final temperature from the initial temperature and dividing by the desired ramp rate. In the Figure 4.22 example, if the ramp rate is 2°C/hr, then the run time will be 7 hours  $([68- 54^{\circ}] \div 2 \text{ }^{\circ}\text{C/hr} = 7 \text{ hr})$ .

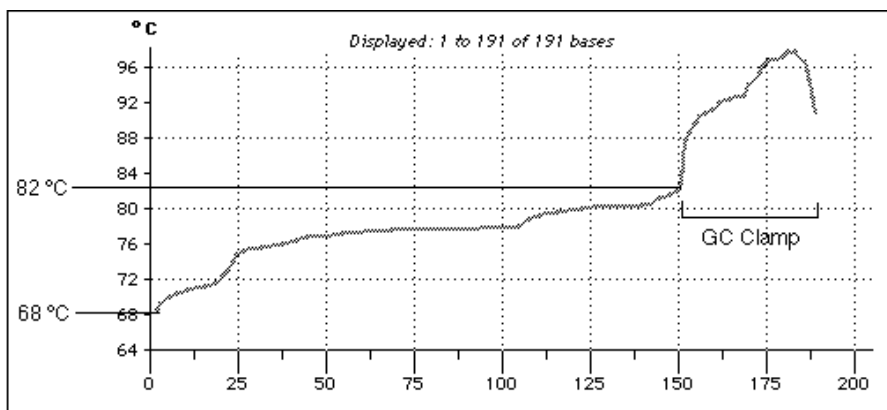

Fig. 4.22. Melting profile of a 191 bp sequence generated with MacMelt software.

### Reagent Preparation

The concentration of acrylamide to use varies for the sample being analyzed on the DCode system. Therefore, a 40% stock solution containing acrylamide and Bis-acrylamide (Bis) should be made. Reagents for casting and running TTGE gels are included in the DCode electrophoresis reagent kit for TTGE, catalog number 170-9171.

For different percent crosslinking, use the equation below to determine the amount of Bis to add. The example stock solution below is for an acrylamide/bis ratio of 37.5:1.

#### 40% Acrylamide/Bis (37.5:1)

Reagent	Amount
Acrylamide	38.93 g
Bis-acrylamide	1.07 g
dH <sub>2</sub> O	to 100.0 ml

Filter through a 0.45 μ filter and store at 4 °C.

Polyacrylamide gels are described by reference to two characteristics:

- 1) The total monomer concentration (%T)
- 2) The crosslinking monomer concentration (%C)

$$\%T = \frac{\text{gm acrylamide} + \text{gm bis-acrylamide}}{\text{Total Volume}} \times 100$$

$$\%C = \frac{\text{g bis-acrylamide}}{\text{gm acrylamide} + \text{g bis-acrylamide}} \times 100$$

The table below provides the percentage acrylamide/bis needed for a particular size range.

Gel Percentage	Base Pair Separation
6%	300–1,000 bp
8%	200–400 bp
10%	100–300 bp

**40% Acrylamide/Bis Solutions (1.25x TAE, 6M urea)**

Reagent	6% Gel	8% Gel	10% Gel	12% Gel
40% Acrylamide/Bis	6.0 ml	8.0 ml	10.0 ml	12.0 ml
50x TAE	1.0 ml**	1.0 ml**	1.0 ml**	1.0 ml**
Urea*	14.4 g	14.4 g	14.4 g	14.4 g
TEMED	40.0 µl	40.0 µl	40.0 µl	40.0 µl
10% Ammonium persulfate	400.0 µl	400.0 µl	400.0 µl	400.0 µl
Total volume	40.0 ml	40.0 ml	40.0 ml	40.0 ml

Add dH<sub>2</sub>O to 40 ml and mix. Cast the gel immediately after adding the TEMED and ammonium persulfate.

\* For 7 M urea gels, use 16.8 g per 40 ml, for 8 M urea gels, use 19.2 g per 40 ml.

\*\* Adjust this amount for other concentrations of running buffer.

**50x TAE Buffer**

Reagent	Amount	Final Concentration
Tris base	242.0 g	2 M
Acetic acid, glacial	57.1 ml	1 M
0.5 M EDTA, pH 8.0	100.0 ml	50 mM
dH <sub>2</sub> O	to 1,000.0 ml	

Mix. Autoclave for 20–30 minutes. Store at room temperature.

**10% Ammonium Persulfate**

Reagent	Amount
Ammonium persulfate	0.1 g
dH <sub>2</sub> O	1.0 ml

Store at –20°C for about a week.

**2x Gel Loading Dye**

Reagent	Amount	Final Concentration
2% Bromophenol blue	0.25 ml	0.05%
2% Xylene cyanol	0.25 ml	0.05%
100% Glycerol	7.0 ml	70%
dH <sub>2</sub> O	2.5 ml	
Total volume	10.0 ml	

Store at room temperature.

**1.25x TAE Running Buffer**

Reagent	Amount
50x TAE buffer	175 ml
dH <sub>2</sub> O	6,825 ml
Total volume	7,000 ml

## Gel Volumes

The table below provides the required volume for the gel size and spacer thickness.

Spacer Thickness	16 x 16 cm gel
0.75 mm	25 ml
1.00 mm	30 ml
1.50 mm	45 ml

## Sample Preparation

1. It is important to optimize the PCR reaction to minimize unwanted products which may interfere with gel analysis. The PCR products should be evaluated for purity by agarose gel electrophoresis before being loaded onto a denaturing acrylamide gel.
2. For a temporal temperature gradient gel, load 180–300 ng of amplified DNA per well (usually 5–10% of a 100  $\mu$ l PCR volume from a 100 ng DNA template). A wild-type control should be run on every gel.
3. Add an equal volume of 2x gel loading dye to the sample.

## Pre-heating the Running Buffer

1. Fill the electrophoresis tank with 7 L of 1.25x TAE buffer.  
**Note:** It is recommended that the running buffer not be reused. Reusing the running buffer may affect the migration rate and band resolution.
2. Place the temperature control module on top of the electrophoresis tank. Attach the power cord to the temperature control module, turn the power, pump, and heater on. The clear loading lid should be on the temperature control module during preheating.
3. Set the temperature controller to the desired temperature. Set the ramp rate to 200°C/hr. to allow the buffer to reach the desired temperature the quickest.
4. Preheat the buffer to the set temperature. It can take 1 to 1.5 hours for the system to preheat the buffer to the set temperature. Heating the buffer in a microwave helps reduce the preheating time.

## Assembling the TTGE Gel Sandwich

For the temporal temperature gradient gel format, a 16 x 16 cm gel sandwich size is recommended. To insure proper alignment, make sure all plates and spacers are clean and dry before assembling. Use caution when assembling the glass plate sandwiches. Wear gloves and eye protection at all times.

1. Assemble the gel sandwich on a clean surface. Lay the large rectangular plate down first, then place the spacers of equal thickness along the short edges of the larger rectangular plate.
2. Place the short glass plate on top of the spacers so that it is flush with the bottom edge of the long plate.
3. Loosen the black thumb screw of each sandwich clamp by turning it counterclockwise. Place each clamp at the appropriate side of the gel sandwich with the locating arrows facing up and toward the glass plates (Figure 4.24).

## Temperature Controller

The temperature controller maintains the desired buffer temperature in the DCode system.

### Turning on the Controller

Turn the controller on by pressing the power button and wait for the controller to initialize. The controller will display the following screens in order:

- The program code
- The date code and serial code
- The hours used
- The temperature control screen (see Fig. 1).

The controller is now ready to be programmed.

### Setting the Set Temperature and Ramp Rate

1. From the temperature control screen, use the arrow keys to adjust the Set Temperature to your desired target temperature in °C (Fig. 1)
2. Use the ↻ key to display the ramp control screen. (Fig. 2.)
3. From the ramp control screen, use the arrow keys to set the desired temperature Ramp Rate in °C per hour. Note that the maximum ramp rate for the DCode is 50°C /hr. If the target Ramp Rate is set using the controller to higher than 50°C /hr the maximum ramp rate of 50°C /hr will be used.

4. To toggle between the temperature control screen and the ramp control screen, or to review the set temperature and ramp rate, press the ↻ key at any time

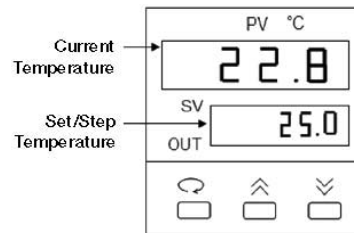

Fig. 1. Temperature Control Screen.

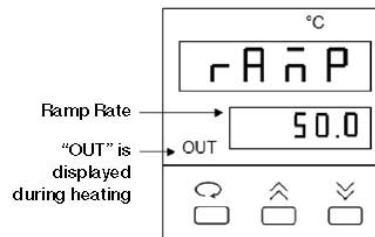

Fig. 2. Ramp Control Screen.

**Note:** Following programming by default the controller displays the Step Temperature rather than the Set Temperature (see Fig 1. below). The step temperature is the next temperature value the system will reach as it heats/cool to reach set temperature. To display the Set Temperature press the ↻ key.



Fig. 4.24. Positioning glass plates, spacers, and clamps.

4. Grasp the gel sandwich firmly. Guide the left and right clamps onto the sandwich so that the long and short plates fit the appropriate notches in the clamp (Figure 4.25). Tighten the screws enough to hold the plates in place.

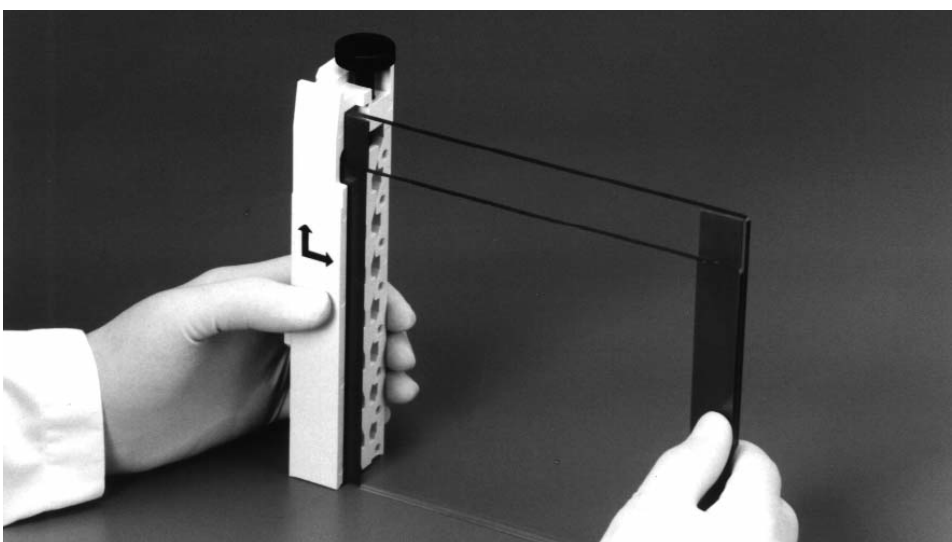
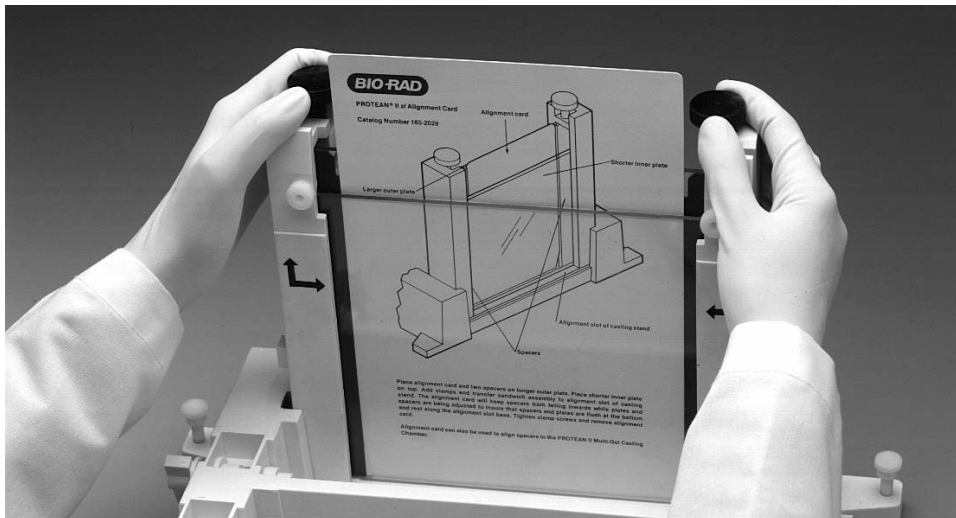

Fig. 4.25. Attaching the clamps to the glass plate assembly.

5. Place the sandwich assembly in the alignment slot (the slot without cams) of the casting stand with the short glass plate forward (Figure 4.26). Loosen the sandwich clamps and insert an alignment card to keep the spacers parallel to the clamps.

**Note:** Always use the alignment slot and alignment card to set the spacers in place. Failure to use these can result in gel leakage when casting, as well as buffer leakage during the run.



**Fig. 4.26. Aligning spacers in the sandwich assembly.**

6. Align the plates and spacers by simultaneously pushing inward on both clamps at the locating arrows while, at the same time, pushing down on the spacers with your thumbs. Tighten both clamps just enough to hold the sandwich in place. Pushing inward on both clamps at the locating arrows will insure that the spacers and glass plates are flush against the sides of the clamps (Figure 4.26).
7. Remove the alignment card. Remove the sandwich assembly from the casting stand and check that the plates and spacers are flush at the bottom. If they are not flush, realign the sandwich and spacers to obtain a good seal (Repeat steps 5–7).
8. When a good alignment and seal is obtained, tighten the clamp screws until it is finger-tight.

### **Casting TTGE Gels**

1. Place the gray sponge onto the front casting slot. The camshafts on the casting stand should have the handles pointing up and pulled out. Place the sandwich assembly on the sponge with the shorter plate facing forward. When the sandwich is placed correctly, press down on the sandwich and turn the handles of the camshaft down so that the cams lock the sandwich in place.
2. Into a 50 ml tube, add the required amount of gel solution (Section 4.3). Add a final concentration of 0.09% (v/v) each of ammonium persulfate and TEMED solution. Cap the tube and mix.
3. Insert a comb in the gel sandwich and tilt it so the teeth are at a slight angle. This will prevent air from being trapped under the comb teeth when pouring the gel solution (Figure 4.27).

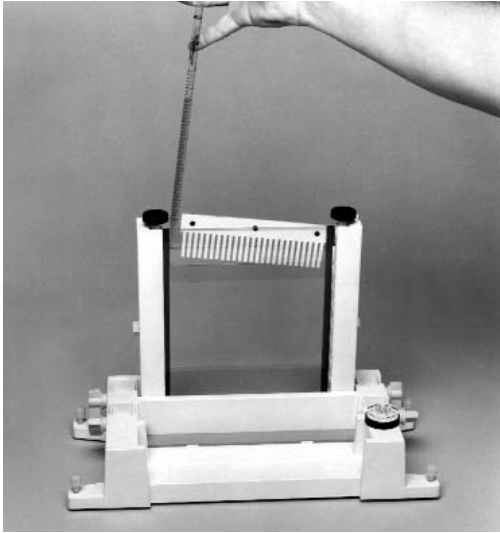

Fig. 4.27. Pouring a TTGE gel.

4. Pour or pipette the gel solution into the sandwich until the gel solution covers the wells of the comb. Straighten the comb to the desired well depth. Add more solution if needed.
5. Allow the gel to polymerize for about 60 minutes. After polymerization, remove the comb by pulling it straight up slowly and gently.
6. Continue with Section 8 for electrophoresis.

## Section 5 Heteroduplex Analysis

### 5.1 Introduction to Heteroduplex Analysis

Heteroduplex Analysis (HA) is based on conformational differences in double-stranded DNA caused by the formation of heteroduplex molecules.<sup>6</sup> Heteroduplex molecules have a mismatch in the double-strand, causing a distortion in its usual conformation and can be detected on polyacrylamide gels due to slower migration than the corresponding homoduplex molecules. Heteroduplex molecules with as little as one mismatch can show a difference in mobility in a gel than homoduplex molecules. Heteroduplexes are generated in the following ways: during PCR of a heterozygous individual or by adding mutant and wild-type DNA in the same PCR reaction or by denaturation and renaturation of mutant and wild-type DNA in a single tube. Both mutant and wild-type samples are run on the same gel and the mobility of the fragments is compared.

The sensitivity of heteroduplex analysis is 80–90% in small DNA fragments (< 300 bp).<sup>16</sup> The sensitivity of mutation detection can be improved when used in conjunction with SSCP.<sup>17</sup> A polyacrylamide analog has been developed (MDE™ or DEM™) which enhances the ability to detect mutations in heteroduplex samples when compared to conventional polyacrylamide gels.<sup>18</sup> The addition of urea to the gel can create a mildly denaturing condition which can increase the separation of heteroduplexes and make mutation detection easier.<sup>16</sup>



A variation of heteroduplex analysis is Conformation Sensitive Gel Electrophoresis (CSGE). This technique exploits the observation that a mildly denaturing environment will enhance the ability of single-based mismatches to produce conformational changes.<sup>19</sup> These changes also increase the differential migration of heteroduplex and homoduplex molecules. Samples are electrophoresed in 6–10% polyacrylamide gels (99:1), tris-taurine buffer and 10% ethylene glycol with 15% formamide as denaturants. Bis (acryloyl) piperazine (BAP) or piperazine diacrylamide (PDA) can also be used instead of bis as a cross-linker.<sup>20</sup> BAP or PDA cross-linker helps to improve the gel strength and increase the pore size in the gel. PCR fragment sizes for CSGE typically run between 300–800 bp in length for optimum mutation detection.<sup>21</sup>

## 5.2 Reagent Preparation

### Heteroduplex Analysis

The concentration and type of acrylamide to use varies for the sample being analyzed on the DCode system. Therefore, a 40% stock solution containing acrylamide and bis-acrylamide (bis) should be made, or a 2x DEM solution. Reagents for casting and running a heteroduplex analysis gel are included in the DCode electrophoresis reagent kit for Heteroduplex Analysis, catalog number 170-9173.

For a different percent crosslinking, use the equation below to determine the amount of bis to add. The example stock solution below is for an acrylamide/bis ratio of 37.5:1.

#### 40% Acrylamide/Bis (37.5:1)

Reagent	Amount
Acrylamide	38.93 g
Bis-acrylamide	1.07 g
dH <sub>2</sub> O	to 100.0 ml

Filter through a 0.45 μ filter and store at 4°C.

Polyacrylamide gels are described by reference to two characteristics:

- 1) The total monomer concentration (%T)
- 2) The crosslinking monomer concentration (%C)

$$\%T = \frac{\text{g acrylamide} + \text{g bis-acrylamide}}{\text{Total Volume}} \times 100$$

$$\%C = \frac{\text{g bis-acrylamide}}{\text{g acrylamide} + \text{g bis-acrylamide}} \times 100$$

#### 10x TBE Buffer

Reagent	Amount	Final Concentration
Tris base	108 g	0.89 M
Boric acid	55 g	0.89 M
0.5 M EDTA, pH 8.0	40 ml	20 mM
dH <sub>2</sub> O	to 1L	

Mix and add dH<sub>2</sub>O to 1 L. Autoclave for 20–30 minutes. Store at room temperature.

**40% Acrylamide/Bis Solutions (1x TBE)**

Reagent	6% Gel	8% Gel	10% Gel	12% Gel
40% Acrylamide/Bis	6 ml	8 ml	10 ml	12 ml
10x TBE (see note)	4 ml	4 ml	4 ml	4 ml
Urea (optional)	see note	see note	see note	see note
TEMED	40 µl	40 µl	40 µl	40 µl
10% Ammonium persulfate	400 µl	400 µl	400 µl	400 µl
Total volume	40 ml	40 ml	40 ml	40 ml

Add dH<sub>2</sub>O to 40 ml and mix. Cast the gel immediately after adding the TEMED and ammonium persulfate.

**Note:** For 0.5x TBE, add 2 ml.  
For 15% urea, add 6 gm.

**2x DEM Solution (0.6x TBE)**

Reagent	1x Gel	0.8x Gel
2x DEM	20 ml	16 ml
10x TBE (see note)	2.4 ml	2.4 ml
Urea (optional)	see note	see note
TEMED	40 µl	40 µl
10% Ammonium persulfate	400 µl	400 µl
Total volume	40 ml	40 ml

Add dH<sub>2</sub>O to 40 ml and mix. Cast the gel immediately after adding the TEMED and ammonium persulfate.

**Note:** For 0.5x TBE, add 2 ml.  
For 1x TBE, add 4 ml.  
For 15% urea, add 6 gm.

**10% Ammonium Persulfate**

Reagent	Amount
Ammonium persulfate	0.1 g
dH <sub>2</sub> O	1.0 ml

Store at -20°C for about a 1 week.

**2x Gel Loading Dye**

Reagent	Amount	Final Concentration
2% Bromophenol blue	0.25 ml	0.05%
2% Xylene cyanol	0.25 ml	0.05%
100% Glycerol	7.0 ml	70%
dH <sub>2</sub> O	2.5 ml	
Total volume	10.0 ml	

Store at room temperature.

**1x TBE Running Buffer**

Reagent	2 L Buffer	7 L Buffer
10x TBE buffer	200 ml	700 ml
dH <sub>2</sub> O	1,800 ml	6,300 ml

**0.6x TBE Running Buffer**

Reagent	2 L Buffer	7 L Buffer
10x TBE buffer	120 ml	420 ml
dH <sub>2</sub> O	1,880 ml	6,580 ml

### CSGE Analysis

For a different percent crosslinking, use the equation in the heteroduplex analysis reagent preparation to determine the amount of crosslinker to add. The example stock solution below is for an acrylamide/PDA ratio of 99:1.

#### 40% Acrylamide/PDA (99:1)

Reagent	Amount
Acrylamide	198.0 g
PDA or BAP	2.0 g
dH <sub>2</sub> O	to 500.0 ml

Filter through a 0.45 µ filter. Store at 4°C.

#### 10x TTE Buffer

Reagent	Amount	Final Concentration
Tris base	107.8 g	0.89 M
Taurine	18.8 g	0.15 M
EDTA	1.9 g	5 mM
dH <sub>2</sub> O	to 1,000 ml	

Mix. Autoclave for 20–30 minutes. Store at room temperature.

#### 10% Acrylamide/PDA Gel

Reagent	Amount	Final Concentration
40% Acrylamide/PDA (see note)	10.0 ml	10%
10x TTE	2.0 ml	0.5x
Formamide	6.0 ml	15%
Ethylene Glycol	4.0 ml	10%
dH <sub>2</sub> O	17.6 ml	
TEMED	40.0 µl	
10% Ammonium persulfate	400.0 µl	
Total volume	40.0 ml	

Mix. Cast the gel immediately after adding the TEMED and ammonium persulfate.

**Note:** For 6% acrylamide gel use 6 ml of a 40% stock.  
For 8% acrylamide gel use 8 ml of a 40% stock.  
For 12% acrylamide gel use 12 ml of a 40% stock.

#### 1x TTE Lower Chamber Running Buffer

Reagent	2 L Buffer	7 L Buffer
10x TTE buffer	200 ml	700 ml
dH <sub>2</sub> O	1,800 ml	6,300 ml

#### 0.25x TTE Upper Chamber Running Buffer

Reagent	400 ml Buffer
10x TTE buffer	10 ml
dH <sub>2</sub> O	390 ml

### 5.3 Gel Volumes

The table below provides the required volume for the gel size and spacer thickness.

Spacer Thickness	20 x 20 cm Gel
0.75 mm	30 ml
1.00 mm	40 ml

## 5.4 Sample Preparation

1. It is important to optimize the PCR reaction to minimize unwanted products which may interfere with gel analysis. Heteroduplexes can be generated during PCR by amplifying the mutant and wild-type samples in the same tube. If the samples are amplified in separate tubes, then heteroduplexes can be formed by mixing an equal amount of mutant and wild-type samples in one tube. Heat the tube at 95°C for 5 minutes, then place at 65°C for 1 hour and let slowly cool to room temperature.
2. The PCR products should be evaluated for purity by agarose gel electrophoresis before being loaded onto a heteroduplex gel.
3. About 180–500 ng of heteroduplex DNA (usually 5–15% of the total PCR volume) can be loaded per well.
4. Add an equal amount of 2x gel loading dye to the samples.

## 5.5 Adding the Running Buffer

1. Remove and place the temperature control module on the DCode lid stand.
2. Add 2 or 7 L of running buffer to the electrophoresis tank. For CSGE, the upper buffer concentration is different from the lower buffer concentration; therefore, the pump should not be used.  
**Note:** To improve heat dissipation during electrophoresis, 7 L of buffer can be used.
3. Place the temperature control module on the electrophoresis tank.

## 5.6 Temperature Controller

The temperature controller maintains the desired buffer temperature in the DCode system.

### Turning on the Controller

Turn the controller on by pressing the power button and wait for the controller to initialize. The controller will display the following screens in order:

- The program code
- The date code and serial code
- The hours used
- The temperature control screen (see Fig. 1).

The controller is now ready to be programmed.

### Setting the Set Temperature and Ramp Rate

1. From the temperature control screen, use the arrow keys to adjust the Set Temperature to your desired target temperature in °C (Fig. 1)
2. Use the  key to display the ramp control screen. (Fig. 2.)
3. From the ramp control screen, use the arrow keys to set the desired temperature Ramp Rate in °C per hour. Note that the maximum ramp rate for the DCode is 50°C /hr. If the target Ramp Rate is set using the controller to higher than 50°C /hr the maximum ramp rate of 50°C /hr will be used.

4. To toggle between the temperature control screen and the ramp control screen, or to review the set temperature and ramp rate, press the  key at any time

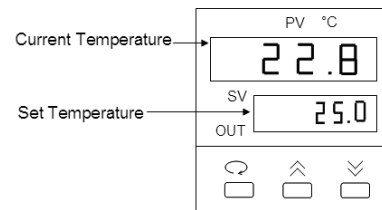

Fig. 1. Temperature Control Screen.

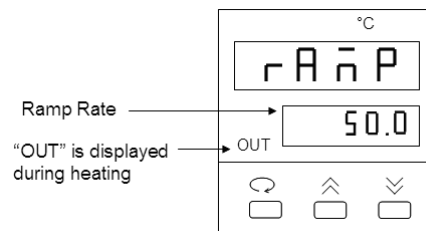



Fig. 2. Ramp Control Screen.

**Note:** Following programming by default the controller displays the Step Temperature rather than the Set Temperature (see Fig 1. below). The step temperature is the next temperature value the system will reach as it heats/cool to reach set temperature. To display the Set Temperature press the  key.

## 5.7 Assembly of a Heteroduplex Analysis Gel Sandwich

For the heteroduplex gel format, a 20 x 20 cm gel sandwich is recommended. To insure proper alignment, make sure all plates and spacers are clean and dry before assembly. Use caution when assembling the glass plate sandwiches. Wear gloves and eye protection at all times.

1. Assemble the gel sandwich on a clean surface. Lay the large rectangular plate down first, then place the left and right spacers of equal thickness along the short edges of the larger rectangular plate.
2. Place a short glass plate on top of the spacers so that it is flush with the bottom edge of the long plate.
3. Loosen the single screw of each sandwich clamp by turning it counterclockwise. Place each clamp by the appropriate side of the gel sandwich with the locating arrows facing up and toward the glass plates (Figure 5.2).

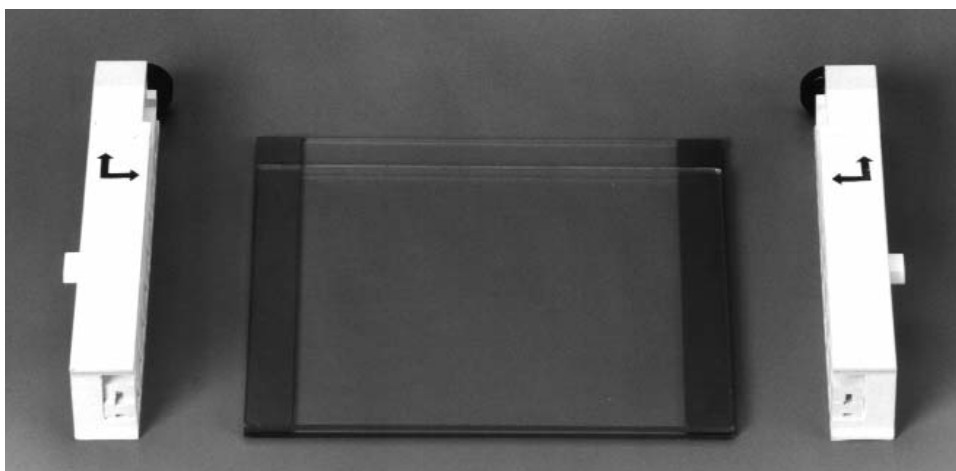

Fig. 5.2. Positioning glass plates, spacers, and clamps.

4. Grasp the gel sandwich firmly. Guide the left and right clamps onto the sandwich so that the long and short plates fit the appropriate notches in the clamp (Figure 5.3). Tighten the screws enough to hold the plates in place.

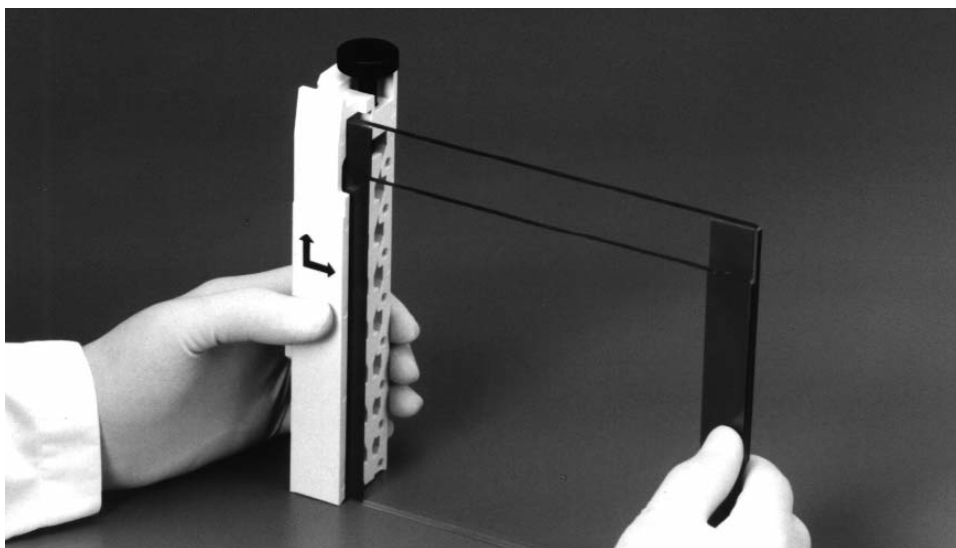
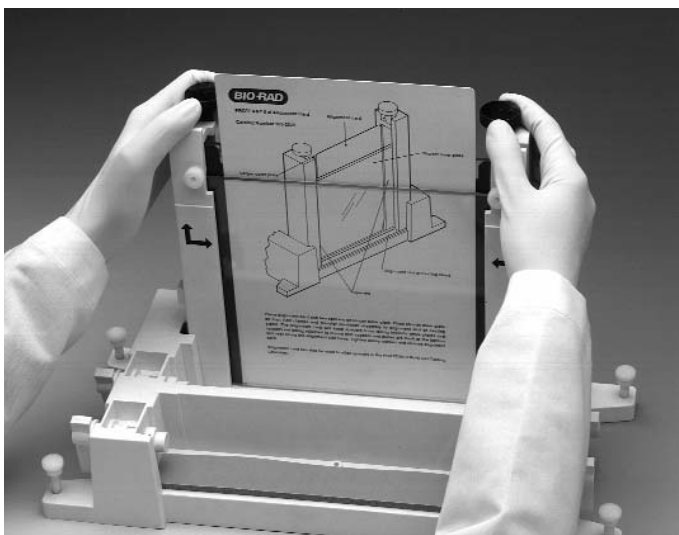

Fig. 5.3. Attaching the clamps to the glass plate assembly.

5. Place the sandwich assembly in the alignment slot (the slot without cams) of the casting stand with the short glass plate forward (Figure 5.4). Loosen the sandwich clamps and insert an alignment card to keep the spacers parallel to the clamps.

**Note:** Always use the alignment slot and alignment card to set the spacers in place. Failure to use these can result in gel leakage when casting, as well as buffer leakage during the run.

6. Align the plates and spacers by simultaneously pushing inward on both clamps at the locating arrows while pushing down on the spacers with your thumbs. Tighten both clamps just enough to hold the sandwich in place. Pushing inward on both clamps at the locating arrows will insure that the spacers and glass plates are flush against the sides of the clamps (Figure 5.4).



**Fig. 5.4. Aligning spacers in the sandwich assembly.**

7. Remove the alignment card. Remove the sandwich assembly from the casting stand and check that the plates and spacers are flush at the bottom. If they are not flush, realign the sandwich and spacers for a good seal (Repeat steps 5–7).
8. When a good alignment and seal are obtained, tighten the clamp screws until it is finger-tight.

## 5.8 Casting Heteroduplex Analysis Gels

1. Place the gray sponge onto the front casting slot. The camshafts on the casting stand should have the handles pointing up and pulled out. Place the sandwich assembly on the sponge with the shorter plate facing forward. When the sandwich is placed correctly, press down on the sandwich and turn the handles of the camshaft down so that the cams lock the sandwich in place.
2. Into a 50 ml tube, add the required amounts of DEM solution (Section 5.2). Add a final concentration of 0.09% (v/v) each of ammonium persulfate and TEMED solutions. Cap the tube and mix.
3. Insert a comb in the gel sandwich and tilt it so that the teeth are at a slight angle. This will prevent air from being trapped under the comb teeth when pouring the gel solution (Figure 5.5).

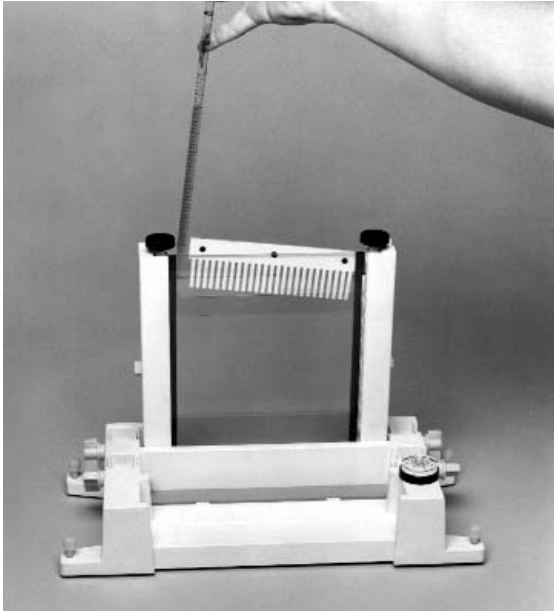

Fig. 5.5. Pouring a heteroduplex analysis gel.

4. Pour or pipette the gel solution into the sandwich until it covers the wells of the comb. Straighten the comb to the desired well depth. Add more solution if needed.
5. Allow the gel to polymerize for about 60 minutes. After polymerization, remove the comb by pulling it straight up slowly and gently.
6. Continue with Section 8 for electrophoresis.

## Section 6 Single-Stranded Conformational Polymorphisms

### 6.1 Introduction to SSCP

The SSCP technique is based on the fact that single-stranded DNA has a sequence-specific secondary structure. Sequence differences as small as a single base change can affect this secondary structure and can be detected by electrophoresis in a non-denaturing polyacrylamide gel.<sup>1</sup> Double-stranded mutant and wild-type samples are first denatured into single strands and then loaded onto the gel. Differences in mobility of the single strands between the control wild-type DNA and the other samples indicate a mutation. SSCP is a widely used mutation screening method because of its simplicity. However, since experimental conditions cannot be predicted for a particular DNA, it is important to optimize gel electrophoresis conditions. The ability to detect single base changes rests on several factors which optimize band resolution.

1. Fragment size: The estimated efficiency for detecting single base changes is 90–95% for fragments less than 350 bp, but the efficiency will decrease as the length of fragment increases.<sup>22</sup>
2. Gel temperature: Migration differences due to a single mutation are observed at buffer temperatures between 4–25°C. Optimal temperature must be determined empirically.
3. Gel additives: In some cases, 5–10% glycerol can be added to the gel to improve the mobility differences in fragments. Since glycerol can reduce the mobility of single-stranded DNA fragments at low temperatures, it is typically used with gels run near room temperature.<sup>22</sup>



4. Crosslinking ratio: The acrylamide/bis ratio determines the percent of crosslinking. SSCP gels generally use 1–2 % crosslinking. Acrylamide concentrations will vary from 5% to 10%.
5. Buffer concentration: Gels are run with TBE buffer at concentrations of 0.5x or 1.0x. In some cases, 0.5x TBE appears to give slightly better results than 1.0x TBE.<sup>23</sup>

SSCP protocols have typically used radioisotope-labeled fragments, but recently non-radioactive or “cold SSCP” methods have been developed.<sup>24</sup> For a more complete description of the SSCP technique, refer to references 1, 22, and 25–29.

When connected to an appropriate external chiller, the DCode system can control the buffer temperatures between 5–25°C. The electrophoresis cooling tank is outfitted with two cooling fingers. Tygon tubing connects the cooling fingers in the electrophoresis tank to an external chiller. The chiller recirculates a coolant through the cooling fingers which, in turn, cools the buffer. The external chiller is set to chill the coolant to approximately –20°C, and the DCode heater regulates the buffer temperature. An example of an SSCP gel run on the DCode system is shown in Figure 6.1.

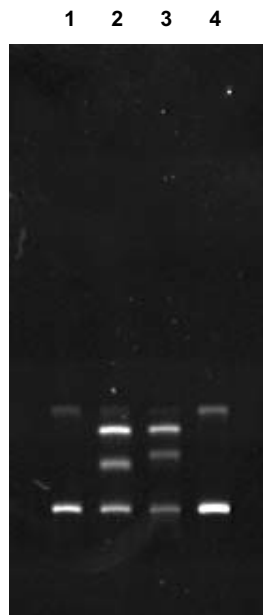

**Fig. 6.1. Amplified mutant and wild-type alleles of exon 8 from the p53 gene.** Separation by SSCP run at constant 30 W for 3.5 hours in 1x TBE on an 8% acrylamide gel (37.5:1) with 3.5% glycerol at 8°C. Lane 1, undenatured mutant allele; lane 2, mutant allele; lane 3, wild-type allele; lane 4, undenatured wild-type allele.

## 6.2 Reagent Preparation

The concentration and type of acrylamide to use varies for the sample being analyzed on the DCode system; therefore, a 40% stock solution containing acrylamide and bis-acrylamide (bis) should be made. Reagents for casting and running an SSCP gel are included in the DCode electrophoresis reagent kit for SSCP, catalog number 170-9172.

For a different percent crosslinking, use the equation below to determine the amount of bis to add. The example stock solution below is for an acrylamide/bis ratio of 37.5:1.

### 40% Acrylamide/Bis (37.5:1)

Reagent	Amount
Acrylamide	38.93 g
Bis-acrylamide	1.07 g
dH <sub>2</sub> O	to 100.0 ml

Filter through a 0.45 μ filter and store at 4°C.

Polyacrylamide gels are described with reference to two characteristics:

- 1) The total monomer concentration (%T)

$$\%T = \frac{\text{g acrylamide} + \text{g bis-acrylamide}}{\text{Total Volume}} \times 100$$

- 2) The crosslinking monomer concentration (%C)

$$\%C = \frac{\text{g bis-acrylamide}}{\text{g acrylamide} + \text{g bis-acrylamide}} \times 100$$

### 10x TBE Buffer

Reagent	Amount	Final Concentration
Tris base	108 g	0.89 M
Boric acid	55 g	0.89 M
0.5 M EDTA, pH 8.0	40 ml	20 mM
dH <sub>2</sub> O	to 1L	

Mix. Autoclave for 20–30 minutes. Store at room temperature.

### 40% Acrylamide/Bis Solutions (1x TBE)

Reagent	6% Gel	8% Gel	10% Gel	12% Gel
40% Acrylamide/Bis	6 ml	8 ml	10 ml	12 ml
10x TBE (see note)	4 ml	4 ml	4 ml	4 ml
100% Glycerol (optional)	see note	see note	see note	see note
TEMED	40 μl	40 μl	40 μl	40 μl
10% Ammonium persulfate	400 μl	400 μl	400 μl	400 μl
dH <sub>2</sub> O	to 40 ml	to 40 ml	to 40 ml	to 40 ml

Add dH<sub>2</sub>O to 40 ml and mix. Cast the gel immediately after adding the TEMED and ammonium persulfate.

**Note:** 0.5x TBE, add 2 ml.  
5% glycerol, add 2 ml.  
10% glycerol, add 4 ml.

### Using Acrylamide and Bis-acrylamide Stock Solutions

Use these calculations to determine the necessary volumes of stock acrylamide and bis-acrylamide solutions to produce gels of any percent and volume.

To determine the monomer and crosslinker ratios:

- (A) is the part of total monomer that is acrylamide

$$A = \frac{\text{gm acrylamide}}{\text{gm acrylamide} + \text{gm bis-acrylamide}}$$

- (B) is the part of total monomer that is bis-acrylamide

$$B = \frac{\text{gm bis-acrylamide}}{\text{gm acrylamide} + \text{gm bis-acrylamide}}$$

To determine the volume of 40% acrylamide stock solution to use:

- Use the calculation for (A) determined above.

$$\frac{(A) (\text{gel } \%) (\text{final volume})}{(40\%) \text{ acrylamide solution}} = \text{ml of 40\% acrylamide (C)}$$

- Use the calculation for (B) determined above.

$$\frac{(B) (\text{gel } \%) (\text{final volume})}{(2\%) \text{ bis-acrylamide solution}} = \text{ml of 2\% bis-acrylamide (D)}$$

#### Acrylamide/Bis Solutions (1x TBE)

Reagent	8% Gel (37.5:1)	X% Gel
40% Acrylamide	7.78 ml	(C) from above
2% Bis	4.27 ml	(D) from above
10x TBE (see note)	4 ml	4 ml
100% Glycerol (optional)	see note	see note
TEMED	40 $\mu$ l	40 $\mu$ l
10% Ammonium persulfate	400 $\mu$ l	400 $\mu$ l
dH <sub>2</sub> O	to 40 ml	to 40 ml

Cast the gel immediately after adding the TEMED and ammonium persulfate.

**Optional:** 0.5x TBE, add 2 ml  
5% glycerol, add 2 ml  
10% glycerol, add 4 ml

#### 10% Ammonium Persulfate

Reagent	Amount
Ammonium persulfate	0.1 g
dH <sub>2</sub> O	1.0 ml

Store at -20°C for about a week.

#### 2x Gel Loading Dye

Reagent	Amount	Final Concentration
Bromophenol blue	0.05 g	0.05%
Xylene cyanol	0.05 g	0.05%
Formamide	9.5 ml	95%
0.5 M EDTA, pH 8	0.4 ml	20 mM
Total volume	10.0 ml	

Store at room temperature.

### 1x TBE Running Buffer

Reagent	Amount
10x TBE buffer	700 ml
dH <sub>2</sub> O	6,300 ml

### 6.3 Gel Volumes

The table below provides the required volume for the gel size and spacer thickness.

Spacer Thickness	20 x 20 cm Gel
0.75 mm	30 ml
1.00 mm	40 ml

### 6.4 Sample Preparation

1. It is important to optimize the PCR reaction to minimize unwanted products which may interfere with gel analysis. The PCR products should be evaluated for purity by agarose gel electrophoresis before being loaded onto an SSCP gel.
2. 150–300 ng of amplified DNA (usually 5–10% of the total PCR volume) can be loaded per well. Aliquot the proper amount of sample into separate tubes and add equal volume of 2x SSCP gel loading dye. For extra control, the undenatured samples can be run on the gel.
3. Denature the samples at 95°C for 5 minutes and then place on ice.

## 6.5 Temperature Controller

The temperature controller maintains the desired buffer temperature in the DCode system.

### Turning on the Controller

Turn the controller on by pressing the power button and wait for the controller to initialize. The controller will display the following screens in order:

- The program code
- The date code and serial code
- The hours used
- The temperature control screen (see Fig. 1).

The controller is now ready to be programmed.

### Setting the Set Temperature and Ramp Rate

1. From the temperature control screen, use the arrow keys to adjust the Set Temperature to your desired target temperature in °C (Fig. 1)
2. Use the ↻ key to display the ramp control screen. (Fig. 2.)
3. From the ramp control screen, use the arrow keys to set the desired temperature Ramp Rate in °C per hour. Note that the maximum ramp rate for the DCode is 50°C /hr. If the target Ramp Rate is set using the controller to higher than 50°C /hr the maximum ramp rate of 50°C /hr will be used.
4. To toggle between the temperature control screen and the ramp control screen, or to review the set temperature and ramp rate, press the ↻ key at any time

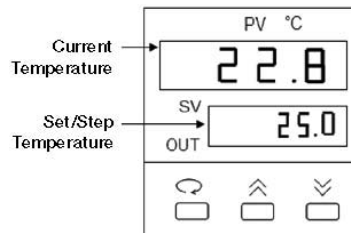

Fig. 1. Temperature Control Screen.

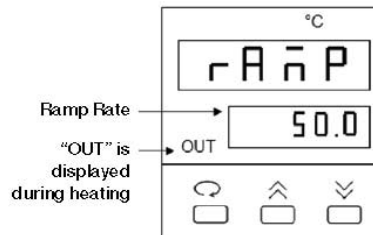

Fig. 2. Ramp Control Screen.

**Note:** Following programming by default the controller displays the Step Temperature rather than the Set Temperature (see Fig 1. below). The step temperature is the next temperature value the system will reach as it heats/cool to reach set temperature. To display the Set Temperature press the ↻ key.

## 6.6 Cooling the Running Buffer and Chiller Settings

1. To chill the buffer in the DCode system, an external chiller is required. For buffer temperature runs between 5–20°C, the chiller must be able to be set to –20°C and have a built-in pump to recirculate the coolant (recommended chillers: Haake Model K20 and Lauda Model RMS-6 or equivalent).
2. Add enough 50% ethylene glycol to the external chiller to fill the coolant reservoir.  
**Note:** To achieve maximum chilling in the electrophoresis cooling tank, do not use ethylene glycol concentrations greater than 50%.
3. Fill the DCode electrophoresis cooling tank with 7 L of desired running buffer.  
**Note:** It is recommended that the running buffer not be re-used. Because this may affect the migration rate and band resolution.
4. Connect two pieces of Tygon tubing to the inlet and outlet on the external chiller. Attach the quick-release connectors to the other end of the tubing.
5. Connect the quick-release tubing connections to the cooling finger leads on the back of the tank. Turn the chiller on and set the temperature to –20°C. Setting the chiller to –20°C assures maximum chilling effect, but some chillers may not reach the set temperature due to the 50% ethylene glycol concentration. Place the temperature control module onto the electrophoresis tank. The clear loading lid should be on the temperature control module.  
**Note:** For electrophoresis runs between 20–25°C, the chiller should be set to –5 to 0°C.
6. Attach the power cord. Turn the power, pump, and heater on. Set to the desired running temperature, with a temperature ramp rate to 200°C/hr. This allows the buffer to reach the desired temperature the quickest.
7. Pre-chill the buffer to the set temperature. It can take 1–1.5 hours for the system to chill the buffer to 5–10°C. Pre-chilling the buffer overnight at 4°C helps reduce the pre-chilling time.

## 6.7 Assembling the SSCP Gel Sandwich

For SSCP gel formats, a 20 x 20 cm gel sandwich size is recommended. To insure proper alignment, make sure all plates and spacers are clean and dry before assembly. Use caution when assembling the glass plate sandwiches. Wear gloves and eye protection at all times.

1. Assemble the gel sandwich on a clean surface. Lay the large rectangular plate down first, then place the left and right spacers of equal thickness along the short edges of the larger rectangular plate.
2. Place a short glass plate on top of the spacers so that it is flush with the bottom edge of the long plate.
3. Loosen the single screw of each sandwich clamp by turning it counterclockwise. Place each clamp by the appropriate side of the gel sandwich with the locating arrows facing up and toward the glass plates (Figure 6.3).



Fig. 6.3. Positioning glass plates, spacers, and clamps.

4. Grasp the gel sandwich firmly. Guide the left and right clamps onto the sandwich so that the long and short plates fit the appropriate notches in the clamp (Figure 6.4). Tighten the screws enough to hold the plates in place.

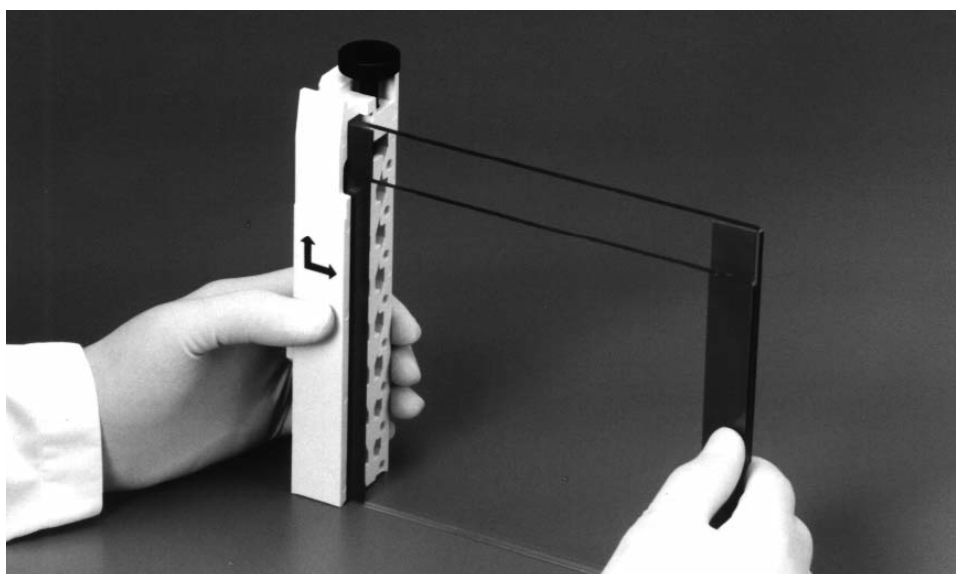
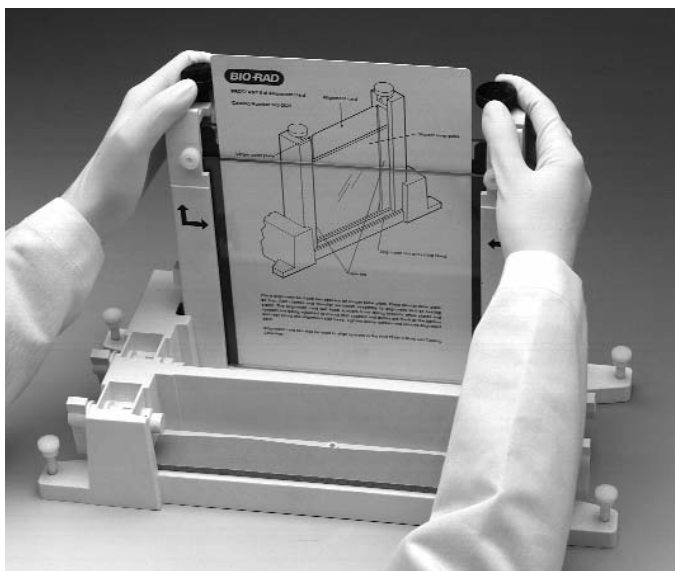

Fig. 6.4. Attaching the clamps to the glass plate assembly.

5. Place the sandwich assembly in the alignment slot (the slot without cams) of the casting stand with the short glass plate forward (Figure 6.5). Loosen the sandwich clamps and insert an alignment card to keep the spacers parallel to the clamps.

**Note:** Always use the alignment slot and alignment card to set the spacers in place. Failure to use these can result in gel leakage when casting, as well as buffer leakage during the run.

6. Align the plates and spacers by simultaneously pushing inward on both clamps at the locating arrows while, at the same time, pushing down on the spacers with your thumbs. Tighten both clamps just enough to hold the sandwich in place. Pushing inward on both clamps at the locating arrows will insure that the spacers and glass plates are flush against the sides of the clamps (Figure 6.5).



**Fig. 6.5. Aligning spacers in the sandwich assembly.**

7. Remove the alignment card. Remove the sandwich assembly from the casting stand and check that the plates and spacers are flush at the bottom. If the spacers and glass plates are not flush, realign the sandwich and spacers to obtain a good seal (Repeat steps 5–7).
8. Once a good alignment and seal are obtained, tighten the clamp screws until it is finger-tight.

### **6.8 Casting SSCP Gels**

1. Place the gray sponge onto the front casting slot. The camshafts on the casting stand should have the handles pointing up and pulled out. Place the sandwich assembly on the sponge with the shorter plate facing forward. When the sandwich is placed correctly, press down on the sandwich and turn the handles of the camshaft down so that the cams lock the sandwich in place.
2. Into a 50 ml tube, add the required amounts of solutions (Section 6.2). Add a final concentration of 0.09% (v/v) each of ammonium persulfate and TEMED solutions. Cap the tube and mix.
3. Insert a comb in the gel sandwich and tilt it so the teeth are at a slight angle. This will prevent air from being trapped under the comb teeth while pouring the gel solution (Figure 6.6).



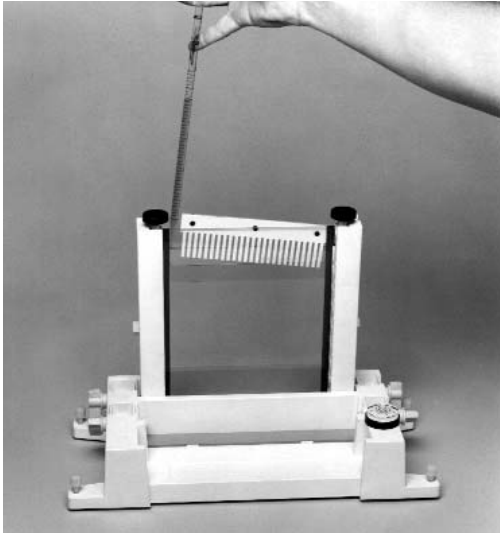

Fig. 6.6. Pouring a SSCP gel.

4. Pour or pipette the gel solution into the sandwich until it covers the wells of the comb. Straighten the comb to the desired well depth. Add more solution if needed.
5. Allow the gel to polymerize for about 60 minutes. After polymerization, remove the comb by pulling it straight up slowly and gently.
6. Continue with Section 8 for electrophoresis.

## Section 7 Protein Truncation Test

### 7.1 Introduction to PTT

Increasing numbers of genes with translation terminating mutations are being identified. The Protein Truncation Test (PTT) is a mutation screening method that detects truncated proteins after translation of the coding sequence.<sup>7,30</sup> There are six steps associated with the PTT assay. The first step is to amplify by PCR a template RNA sample. The second step requires a reverse transcriptase reaction of the starting mRNA to make cDNA. The third step amplifies the sequence of interest and incorporates a tailed primer sequence. This tailed primer contains a T7 promoter and eukaryotic translation initiation sequence. These sequences are needed for *in vitro* transcription and translation. The fourth step checks the PCR product on an agarose gel for quality, size, and approximate quantity. In the fifth step, the PCR products are transcribed with RNA polymerase and translated into peptides. There are commercial kits that couple the transcription and translation reaction in one tube using rabbit reticulocyte lysate (Promega). Detection of the translation products is done by adding radiolabeled amino acids, typically <sup>3</sup>H-Leucine or <sup>35</sup>S-methionine, to the translation reaction. The final step involves analyzing the translation products on an SDS-PAGE gel to determine their length. The gel is normally treated with a fluorographic-enhancing reagent to reduce the exposure time to X-ray film. Truncated proteins are identified by size differences when compared to full-length control proteins.

## 7.2 Reagent Preparation

The concentration and type of acrylamide to use varies for the sample being analyzed on the DCode system, therefore, a 40% stock solution containing acrylamide and bis-acrylamide (Bis) should be made. Reagents for casting and running PTT gels are included in the DCode electrophoresis reagent kit for PTT, catalog number 170-9174.

For different percent crosslinking, use the equation below to determine the amount of Bis to add. The example stock solution below is for an acrylamide/bis ratio of 37.5:1.

### 40% Acrylamide/Bis (37.5:1)

Reagent	Amount
Acrylamide	38.93 g
Bis-acrylamide	1.07 g
dH <sub>2</sub> O	to 100.0 ml

Filter through a 0.45 μ filter and store at 4°C.

Polyacrylamide gels are described with reference to two characteristics:

- 1) The total monomer concentration (%T)
- 2) The crosslinking monomer concentration (%C)

$$\%T = \frac{\text{gm acrylamide} + \text{gm bis-acrylamide}}{\text{total volume}} \times 100$$

$$\%C = \frac{\text{gm bis-acrylamide}}{\text{gm acrylamide} + \text{gm bis-acrylamide}} \times 100$$

### 1.5 M Tris-HCl, pH 8.8

Reagent	Amount
Tris base	54.51 g
dH <sub>2</sub> O	150.0 ml

Adjust to pH 8.8 with 6 N HCl. Add dH<sub>2</sub>O to 300 ml.

### 0.5 M Tris-HCl, pH 6.8

Reagent	Amount
Tris base	6.0 g
dH <sub>2</sub> O	60.0 ml

Adjust to pH 6.8 with 6 N HCl. Add dH<sub>2</sub>O to 100 ml and. Store at 4°C.

### 10% SDS

Reagent	Amount
SDS	10.0 g
dH <sub>2</sub> O	to 100.0 ml

Mix and store at room temperature.

### 10x Tris/Glycine/SDS Buffer, pH 8.3

Reagent	Amount	Final Concentration
Tris base	30.3 g	0.25 M
Glycine	144.1 g	1.92 M
SDS	10.0 g	1%
dH <sub>2</sub> O	to 1,000 ml	

Mix and store at room temperature.

The table below provides the percentage acrylamide/bis needed for a particular size range.

Gel Percentage	Base Pair Separation
7.5%	35–95 kD
10%	15–70 kD
15%	10–40 kD

#### Separating Gel–0.375 M Tris, pH 8.8

Reagent	7.5%	12%	X%
40% Acrylamide/Bis	7.5 ml	12.0 ml	(X%) = (A)* ml
1.5M Tris-HCl, pH 8.8	10.0 ml	10.0 ml	10.0 ml
10% SDS	0.4 ml	0.4 ml	0.4 ml
dH <sub>2</sub> O	17.2 ml	17.2 ml	29.2–(A)*
10% Ammonium persulfate	400.0 µl	400.0 µl	400.0 µl
TEMED	40.0 µl	40.0 µl	40.0 µl
Total volume	40.0 ml	40.0 ml	40.0 ml

Degas for 15 minutes before adding TEMED and ammonium persulfate. Cast the gel immediately after adding the TEMED and ammonium persulfate.

\* The letter A designates the volume of 40% acrylamide/bis solution required to produce the specified percent of gel (X%).

#### 4% Stacking Gel–0.125 M Tris, pH 6.8

Reagent	Amount
40% Acrylamide/Bis	1.0 ml
0.5 M Tris-HCl, pH 6.8	2.5 ml
10% SDS	0.1 ml
dH <sub>2</sub> O	6.4 ml
10% Ammonium Persulfate	50.0 µl
TEMED	10.0 µl
Total volume	10.0 ml

Degas for 15 minutes before adding TEMED and ammonium persulfate. Cast the gel immediately after adding the TEMED and ammonium persulfate.

#### Laemmli Sample Buffer

Reagent	Amount	Final Concentration
0.5 M Tris-HCl, pH 6.8	3.1 ml	62.5 mM
100% Glycerol	6.25 ml	25%
10% SDS	5.0 ml	2%
0.5% Bromophenol blue	0.5 ml	0.01%
dH <sub>2</sub> O	10.15 ml	
Total volume	25.0 ml	

Mix and store at 4°C. Before use add 10 µl β-mercaptoethanol to 590 µl Laemmli buffer. Dilute sample 1:2 with Laemmli buffer.

#### Coomassie Blue Stain

Reagent	Amount	Final Concentration
Coomassie Blue R-250	1.0 g	0.1%
Methanol	400 ml	40%
Acetic acid, glacial	100 ml	10%
dH <sub>2</sub> O	500 ml	
Total volume	1,000 ml	

Mix and store at room temperature.

<b>Coomassie Blue Destain</b>		
<b>Reagent</b>	<b>Amount</b>	<b>Final Concentration</b>
Methanol	400 ml	40%
Acetic acid, glacial	100 ml	10%
dH <sub>2</sub> O	500 ml	
Total volume	1,000 ml	

Mix and store at room temperature.

### 7.3 Gel Volumes

The table below provides the required volume for the gel size and spacer thickness.

<b>Spacer Thickness</b>	<b>20 x 20 cm Gel</b>
0.75 mm	30 ml
1.00 mm	40 ml

### 7.4 Sample Preparation

1. Dilute samples, controls, and protein marker (such as Bio-Rad pre-stained markers) 1:2 with Laemmli sample buffer.

**Note:** Add 10  $\mu$ l  $\beta$ -mercaptoethanol to 590  $\mu$ l Laemmli buffer just before use. This solution is good for 1 day only.

2. Heat the samples at 95–100°C for 5 minutes.

## 7.5 Temperature Controller

The temperature controller maintains the desired buffer temperature in the DCode system.



### Turning on the Controller

Turn the controller on by pressing the power button and wait for the controller to initialize. The controller will display the following screens in order:

- The program code
- The date code and serial code
- The hours used
- The temperature control screen (see Fig. 1).

The controller is now ready to be programmed.

### Setting the Set Temperature and Ramp Rate

1. From the temperature control screen, use the arrow keys to adjust the Set Temperature to your desired target temperature in °C (Fig. 1)
2. Use the  key to display the ramp control screen. (Fig. 2.)
3. From the ramp control screen, use the arrow keys to set the desired temperature Ramp Rate in °C per hour. Note that the maximum ramp rate for the DCode is 50°C /hr. If the target Ramp Rate is set using the controller to higher than 50°C /hr the maximum ramp rate of 50°C /hr will be used.
4. To toggle between the temperature control screen and the ramp control screen, or to review the set temperature and ramp rate, press the  key at any time

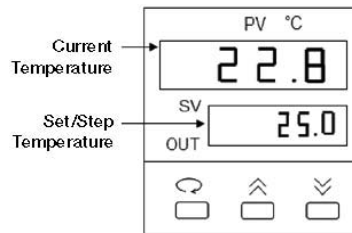

Fig. 1. Temperature Control Screen.

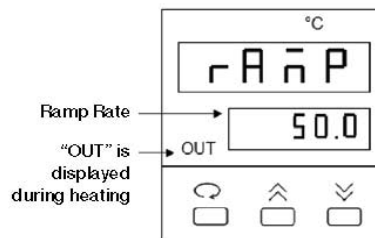



Fig. 2. Ramp Control Screen.

**Note:** Following programming by default the controller displays the Step Temperature rather than the Set Temperature (see Fig 1. below). The step temperature is the next temperature value the system will reach as it heats/cool to reach set temperature. To display the Set Temperature press the  key.

## 7.6 Adding the Running Buffer

1. Remove and place the temperature control module on the DCode lid stand.
2. Add 2 or 7 L of running buffer to the electrophoresis tank.

**Note:** To improve heat dissipation during electrophoresis, 7 L of buffer can be used.

3. Place the temperature control module on the electrophoresis tank.

## 7.7 Assembling the PTT Gel Sandwich

For PTT gel formats, a 20 x 20 cm gel sandwich is used. To insure proper alignment, make sure all plates and spacers are clean and dry before assembly. Use caution when assembling the glass plate sandwiches. Wear gloves and eye protection at all times.

1. Assemble the gel sandwich on a clean surface. Lay the large rectangular plate down first, then place the left and right spacers of equal thickness along the short edges of the larger rectangular plate.
2. Place a short glass plate on top of the spacers so that it is flush with the bottom edge of the long plate.
3. Loosen the single screw of each sandwich clamp by turning counterclockwise. Place each clamp by the appropriate side of the gel sandwich with the locating arrows facing up and toward the glass plates (Figure 7.2).

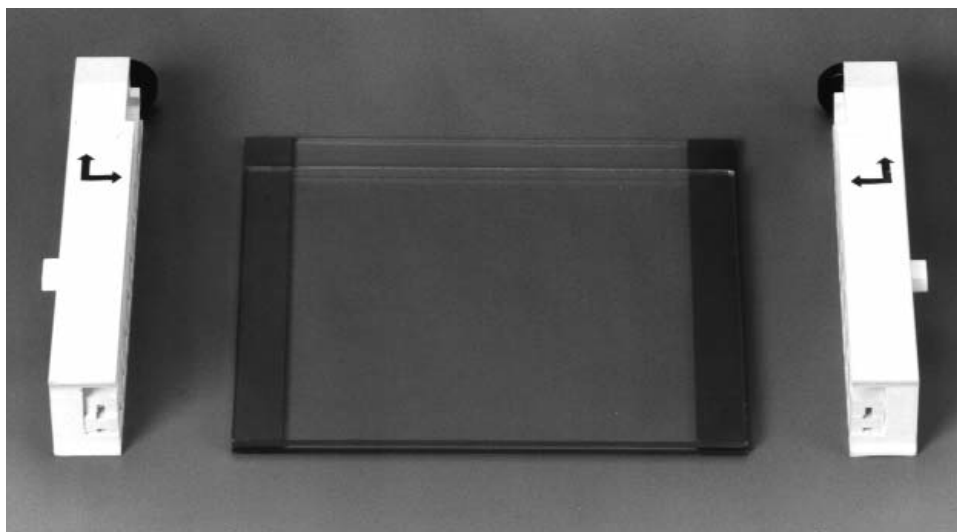

**Fig. 7.2. Positioning glass plates, spacers, and clamps.**

4. Grasp the gel sandwich firmly. Guide the left and right clamps onto the sandwich so that the long and short plates fit the appropriate notches in the clamp (Figure 7.3). Tighten the screws enough to hold the plates in place.

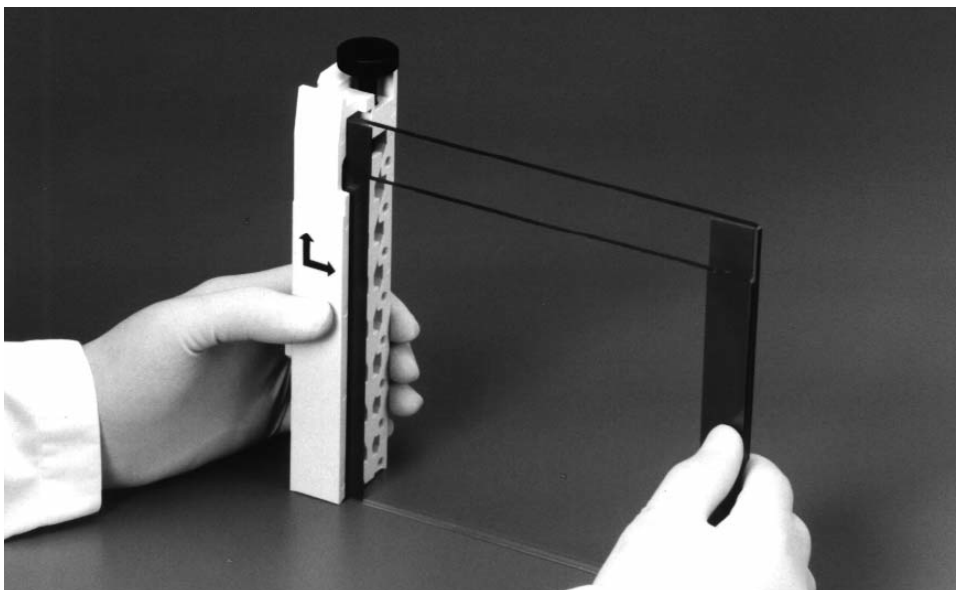

Fig. 7.3. Attaching the clamps to the glass plate assembly.

5. Place the sandwich assembly in the alignment slot (the slot without cams) of the casting stand with the short glass plate forward (Figure 7.4). Loosen the sandwich clamps and insert an alignment card to keep the spacers parallel to the clamps.

**Note:** Always use the alignment slot and alignment card to set the spacers in place. Failure to use these can result in gel leakage when casting, as well as buffer leakage during the run.

6. Align the plates and spacers by simultaneously pushing inward on both clamps at the locating arrows while pushing down on the spacers with your thumbs. Tighten both clamps just enough to hold the sandwich in place. Pushing inward on both clamps at the locating arrows will insure that the spacers and glass plates are flush against the sides of the clamps (Figure 7.4).

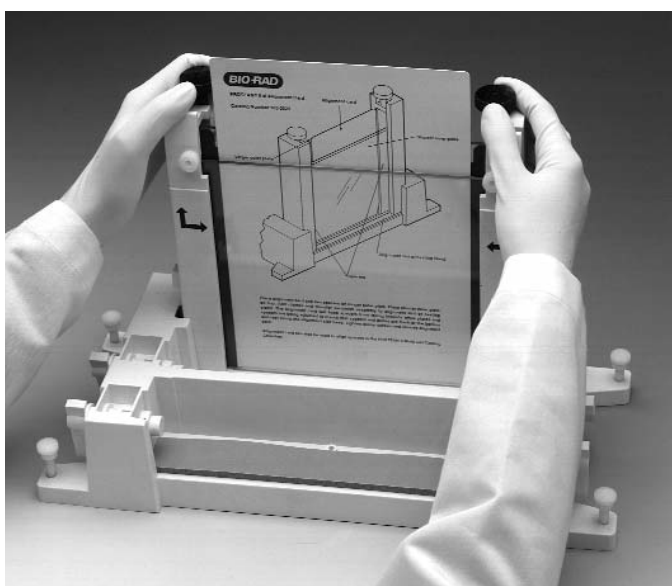

Fig. 7.4. Aligning spacers in the sandwich assembly.

7. Remove the alignment card. Remove the sandwich assembly from the casting stand and check that the plates and spacers are flush at the bottom. If they are not flush, realign the sandwich and spacers for a good seal (repeat steps 5–7).
8. When a good alignment and seal are obtained, tighten the clamp screws until it is finger-tight.

## 7.8 Casting PTT Gels

1. Place the gray sponge onto the front casting slot. The camshafts on the casting stand should have the handles pointing up and pulled out. Place the sandwich assembly on the sponge with the shorter plate facing forward. When the sandwich is placed correctly, press down on the sandwich and turn the handles of the camshaft down so that the cams lock the sandwich in place.
2. PTT samples are typically run in a discontinuous Laemmli gel.<sup>31</sup> Discontinuous gels consist of a resolving or separating (lower) gel and a stacking (upper) gel. The stacking gel acts to concentrate large sample volumes.
3. Insert a comb into the assembled gel sandwich. With a marker pen, place a mark on the glass plate 1–2 cm below the teeth of the comb. This will be the level to which the separating gel is poured. Remove the comb.
4. Into a 50 ml tube, add the required amount of solution for casting the lower or separating gel (Section 7.2). Add a final concentration of 0.09% (v/v) each of ammonium persulfate and TEMED solutions. Cap the tube and mix.
5. Pour or pipette the gel solution into the sandwich until the gel solution reaches the mark on the glass plate.
6. Immediately overlay the monomer solution with water, water-saturated isobutanol, or t-amyl alcohol. Isobutanol or t-amyl alcohol can be applied rapidly with a Pasteur pipet and bulb because very little mixing will occur. If water is used, it must be applied with a needle and syringe, using a steady, even rate of delivery to prevent mixing.
7. Allow the gel to polymerize for 60 minutes. Rinse the overlay solution completely with distilled water. This is especially important with alcohol overlays. Do not allow alcohol to remain on the gels more than 1 hour to prevent dehydration of the top of the gel.
8. Into a 50 ml tube, add the required amount of solution for casting the upper or stacking gel (Section 7.2). Add a final concentration of 0.09% (v/v) each of ammonium persulfate and TEMED solutions. Cap the tube and mix.
9. Insert a comb in the gel sandwich and tilt it so the teeth are at a slight angle. This will prevent air from being trapped under the comb teeth when pouring the gel solution (Figure 7.5).



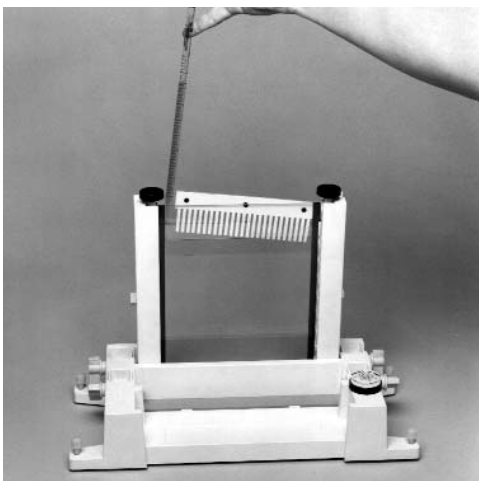

Fig. 7.5. Pouring a PTT gel.

10. Pour or pipette the gel solution into the sandwich until it covers the wells of the comb. Straighten the comb to the desired well depth. Add more solution if needed.
11. Allow the gel to polymerize for about 60 minutes. After polymerization, remove the comb by pulling it straight up slowly and gently.
12. Continue with Section 8 for electrophoresis.

## Section 8 Electrophoresis

### 8.1 Assembling the Upper Buffer Chamber

1. Lay the inner core flat on a bench. Make sure the white U-shaped gasket on the inner core is seated properly and clear of any particles that may cause leakage, such as residual gel material.
2. After the gel has polymerized, release the gel sandwich from the casting stand by turning the camshafts 180°, to the up position, and pulling them outward. Remove the sandwich and the comb.

**Note:** To easily visualize the wells when loading the samples, use a permanent marker to mark the wells.

3. With the short glass plate facing the core, position the gel sandwich so that the locating pins on the core are fitted into the grooves on the outside surface of the sandwich clamps (Figure 8.1). The gel sandwich should be positioned at an angle of 20° with the core. Keeping this angle to a minimum will prevent distortion of the gasket while the sandwich slides into place.

**Note:** To help insure a good buffer seal, lubricate the entire front of the core gaskets with water or running buffer prior to attaching the gel sandwich to the core. This will allow the glass plate sandwich to slide onto the gasket properly.

4. With your fingers below the latch on the core and your thumbs resting on the bottom of the sandwich clamps, gently push the gel sandwich down onto the core with one simple motion. You should be able to hear a click. The upper edge of the short inner glass plate should be seated against the notches of the U-shaped gasket and the tabs of each clamp should be held securely against the latch assemblies on both sides of the core (Figure 8.1).

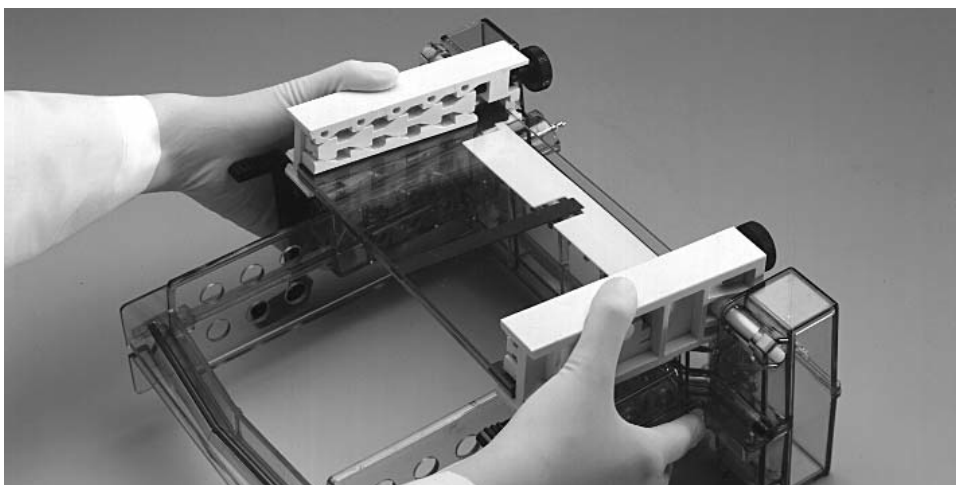

**Fig. 8.1. Attaching the sandwich assembly on to the core.**

5. Turn the core to its other side and repeat steps 1–4 to attach the second gel sandwich.
 

**Note:** When the gel sandwich has been properly installed, the shorter inside glass plate will be forced against the notch in the U-shaped gasket to create a leak-proof seal. Always inspect the contact between the gasket and glass plate to make sure the glass plate is seated against the notch in the gasket and is not resting above or below this notch. Improper installation of the gel sandwich can result in buffer leakage during the run.
6. If only one gel is to be run, assemble a set of glass plates without the spacers. Place the short glass plate on top of the long glass plate. Guide the left and right clamps onto the sandwich so that the plates fit the appropriate notches in the clamp. Insure that the bottom of the glass plates are flush. Tighten the screws enough to hold the plates in place. No further alignment is necessary. Attach it to the other side of the core to form an upper chamber dam.
7. Pour 350 ml of running buffer into the upper buffer chamber. At this point, check the integrity of the upper buffer seal. If the buffer appears to be leaking, pour the running buffer into a beaker, remove the gel sandwich assemblies (Section 8.4), re-lubricate the gasket, and repeat steps 1–4.

#### **DGGE, CDGE, and SSCP Gels**

1. The electrophoresis tank should contain 7 L the appropriate running buffer.
2. When the running buffer has reached the desired temperature, turn the system off. Disconnect the power cord.
3. Remove and place the temperature control module on the DCode lid stand. Place the core and the attached gel assemblies into the buffer chamber by positioning the red button towards the right hand side and the black button along the left hand side of the system. Place the temperature control module on top of the electrophoresis tank.
 

**Note:** The core fits into the tank in one orientation only, allowing the core to lock in place.
4. Connect the power cord and turn the power, pump, and heater on. Remove the clear loading lid and wash the wells with running buffer to remove any unpolymerized gel material/leached denaturants from the wells. If necessary, add more buffer to the “max” line on the electrophoresis tank. Place the clear loading lid back onto the temperature control module.
5. Allow the system to reach the set initial temperature before loading samples. This may take 10–15 minutes.

### **TTGE Gels**

1. The electrophoresis tank should contain 7 L of the appropriate running buffer.
2. When the running buffer has reached the desired temperature, turn the system off. Disconnect the power cord.
3. Remove and place the temperature control module on the DCode lid stand. Place the core and the attached gel assemblies into the buffer chamber by positioning the red button towards the right hand side and the black button along the left hand side of the system. Place the temperature control module on top of the electrophoresis tank.

**Note:** The core fits into the tank in one orientation only, allowing the core to lock in place.

4. Connect the power cord and turn power, pump and heater on. Remove the clear loading lid and wash the wells with running buffer to remove any unpolymerized gel material/leached denaturants from the wells. If necessary, add more buffer to the “max” line on the electrophoresis tank. Place the clear loading lid back onto the temperature control module.
5. Allow the system to reach the set initial temperature before loading samples. This may take 10–15 minutes.
6. When the set initial temperature is reached, press the °C/RR button to select the ramp rate. Set the desired ramp rate using the raise and lower buttons. Allow the heater to equilibrate to the lower ramp rate for 5–10 minutes before loading samples. Press the °C/RR button to return to the temperature readout.

### **Heteroduplex, CSGE, and PTT Gels**

1. The electrophoresis tank should contain at least 2 L of the appropriate running buffer.
2. Remove and place the temperature control module on the DCode lid stand. Place the core and the attached gel assemblies into the buffer chamber by positioning the red button towards the right hand side and the black button along the left hand side of the system. Place the temperature control module on top of the electrophoresis tank.

**Note:** The core fits into the tank in one orientation only, allowing the core to lock in place.

## **8.2 Sample Loading**

1. Remove the clear loading lid. Wash the wells with running buffer to remove any unpolymerized gel material or denaturants in the wells.
2. Load the samples using a pipetman and a sequencing loading tip. Be careful not to pierce the wells during sample delivery.
3. Place the clear loading lid on top of the temperature control module.

## **8.3 Running the Gel**

1. Attach the electrical leads to a suitable DC power supply. Recommended power supply: Bio-Rad’s Power Pac 300 or 3000.

### **DGGE, CDGE, and TTGE Gels**

1. For DGGE and CDGE run the gel at 130 volts. Apply power to the DCode system and begin electrophoresis. As a precaution, always set the voltage, current, and power limits when possible.

**Note:** The voltage should not exceed 180 V, electrophoretic heating may affect results.

2. For TTGE runs, set the desired final temperature and run the gel at 130 volts.

**Note:** The voltage should not exceed 150 V for TTGE runs, electrophoretic heating may affect the temperature gradient.

**Optional:** If your power supply has a built-in timer, set the power supply timer to the desired run time.

3. The run time should be determined empirically for each fragment being analyzed. As a reference during electrophoresis, two marker dyes in the 2x gel loading dye can be used to determine when to stop a DGGE and CDGE run. The dyes are bromophenol blue (dark blue) and Xylene cyanol (light blue). For a TTGE run, the run time is dependent on the temperature ramp rate. Refer to Section 4.3 for determining TTGE run conditions.

### SSCP Gels

1. Run the gel at 20–40 W constant power for 2–6 hours or until desired resolution is achieved. The run time should be determined empirically for each fragment being analyzed.

**Note:** Electrophoresis runs at high power settings (30–40 W) may generate gel heating which causes the “smiling effect” (bands curve upward at both sides of the gel).

2. As a reference during electrophoresis, two marker dyes in the 2x SSCP gel loading dye can be used to determine when to stop a run. The dyes are bromophenol blue (dark blue) and Xylene cyanol (light blue).

**Optional:** When using radioactive samples, the pump may be turned off during electrophoresis to reduce radioactive contamination.

3. Apply power to the DCode system and begin electrophoresis. As a precaution, always set the voltage, current, and power limits when possible.

### Heteroduplex and CSGE Gels

1. For heteroduplex analysis and CSGE, run the gel at 100 volts for 16–20 hours. The run time should be determined empirically for each fragment being analyzed. CSGE gels typically run between 1–2 mAmps. Check to insure the power supply you are using does not shut off when the current is below 2 mAmps.

2. Begin electrophoresis. As a precaution, always set voltage, current, and power limits when possible.

**Note:** The DCode system temperature control module is off for Heteroduplex and CSGE runs.

### PTT Gels

1. It is recommended that gels be run under constant current conditions. For 1.0 mm thick gels, run at 25–35 mAmps/gel for 45 minutes, then increase the current to 40–50 mAmps/gel. Run times are typically between 3 and 5 hours. Under constant current conditions, voltage will gradually increase during the run.

**Optional:** When using radioactive samples, the pump should be turned off during electrophoresis to reduce radioactive contamination.

2. Begin electrophoresis. As a precaution, always set voltage, current, and power limits when possible.

**Note:** The DCode system temperature control module is off for PTT runs.

## 8.4 Removing the Gel

1. After electrophoresis is complete, turn the power supply and system (heater, pump, and power) off. Disconnect the power cord and electrical leads. Allow the heater to cool for approximately 1 minute in the buffer.
2. Remove the temperature control module and place it on the DCode lid stand.

**Caution:** The heater is still hot. Do not touch. Carefully pull the core out of the electrophoresis tank. Pour off the upper buffer into the tank by tilting the core above and over the chamber.

3. Lay the core and gel sandwiches on a padded surface to absorb buffer spills.
  - a. For 16 x 10 cm and 7.5 x 10 cm gels, remove the sandwich assembly with your thumb, pushing on the latches on the core outward and your index finger pushing on the sandwich clamp. Pull the sandwich assembly off the locating pins on the top of the core.
  - b. For 16 x 16 cm and 16 x 20 cm gels, remove the sandwich assembly with your index fingers below the sandwich clamps and your thumbs resting on the latches on the core. Gently remove the assembly by pulling up (in a manner opposite to the way it was attached). Pull the sandwich assembly off the locating pins on the top of the core.

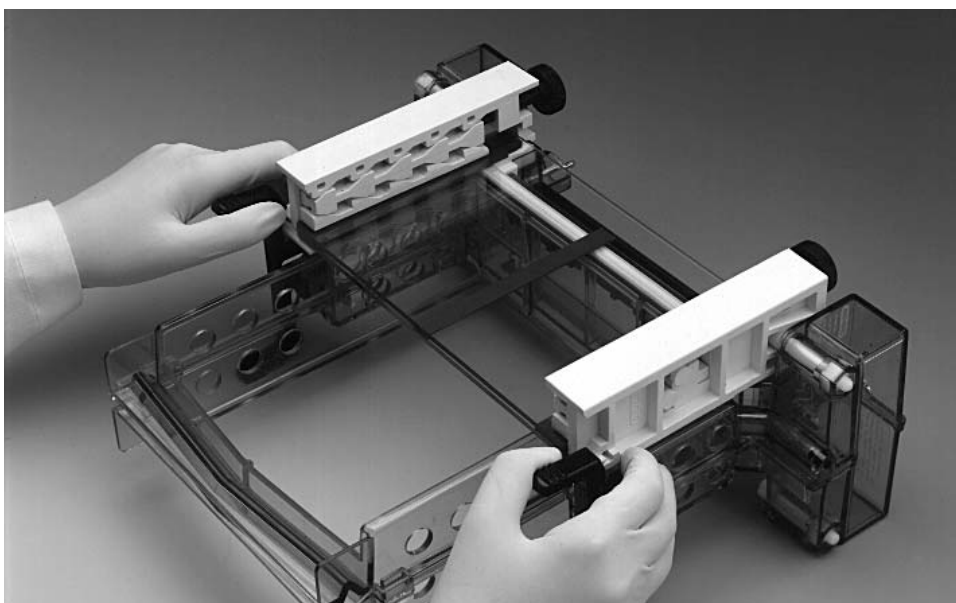

Fig. 8.2. Removing the sandwich assembly from the core.

4. Loosen the single screw of each clamp and remove the clamps from the sandwich. Carefully pry off the shorter glass plate. Do not use a metal spatula to remove the glass plate. This may chip or crack the plate.
5. Remove the spacers and cut one corner of the gel to distinguish between gels.

**Note:** If different buffers are used between runs it is advisable to rinse the pump with distilled water. Place the DCode module on the DCode stand. Fill a 500 ml beaker with distilled water and place it under the pump inlet tube. Place an empty beaker under the pump outlet tube. Turn the pump on for 1–2 minutes.

## 8.5 Staining and Photographing the Gel

### DGGE, CDGE, TTGE, and Heteroduplex Gels

1. Remove the gel from the glass plate.
2. Place the gel into a dish containing 250 ml of running buffer and 25  $\mu$ l of 10 mg/ml ethidium bromide (50  $\mu$ g/ml). Stain for 5–15 minutes.
2. After staining, carefully transfer the gel into a dish containing 250 ml of 1x running buffer. Destain for 5–20 minutes.
3. Place the gel on a UV transilluminator and photograph (Gel Doc™ 1000 system catalog number 170-7520 through 170-7527 or Bio-Rad's Polaroid Gel Documentation System, catalog numbers 170-3742 through 170-3749).

### SSCP Gels

1. Remove the gel from the glass plate. For radioactive SSCP gels, proceed to step 5.  
**Caution:** Use caution when handling radioisotopes. Proper handling and disposal of radioactive material should be followed.
2. Place the gel into a dish containing 250 ml of running buffer and 1:10,000 dilution SYBR® Green II (Molecular Probes, Inc.). Stain for about 30 minutes. The gel can also be stained with Radiant™ Red stain (Bio-Rad catalog number 170-3122). Place the gel into a dish containing 250 ml of running buffer and 1:1,000 dilution Radiant Red stain. Stain for about 30 minutes.
3. After staining, carefully transfer the gel into a dish containing 250 ml of running buffer. Destain for 30 minutes if needed.
4. Place the gel on a UV transilluminator and photograph.
5. Gels that have been labeled with radioisotopes must be autoradiographed or exposed to a storage phosphor imaging screen (GS-525 Molecular Imager™ screen). Carefully place a 3MM Whatman® paper on top of the gel. Gently slide your hand across the paper to adhere the gel to the paper and to remove any air bubbles. Flip the gel over and place a Saran Wrap™ plastic wrap evenly on top of the gel without creating any bubbles. This helps to keep the gel intact and prevents any contamination to the gel dryer. Place the gel on a gel dryer for about 60 minutes at 60°C.
6. Expose the gel to film or a phosphor imaging screen. Scan the imaging screen on a storage phosphor imaging system (GS-525 Molecular Imager™ system catalog number 170-7320 through 170-8305). Develop the film after proper exposure time.

### PTT Gels

1. Remove the gel from the glass plate.
2. To visualize the protein standards, place the gel into a dish containing 250 ml of Coomassie® blue stain. Stain for 20–30 minutes.
3. After staining, carefully transfer the gel into a dish containing 250 ml of Coomassie destaining solution. Destain until the background disappears, usually about 1–3 hours.
4. Gels that have been labeled with radioisotopes must be autoradiographed or exposed to a storage phosphor imaging screen (GS-525 Molecular Imager screen). Since <sup>35</sup>S or <sup>3</sup>H are weak beta emitters and are typically used as a radioactive label, the gel should be treated with a commercial fluorographic enhancing reagent to reduce the film exposure time (*i.e.* Amplify™ from Amersham). Fluorographic reagents are not needed if the sample is exposed to a phosphor imaging screen.

**Caution:** Use caution when handling radioisotopes. Proper handling and disposal of radioactive material should be followed.

5. After the gel has been treated with a fluorographic reagent, carefully place the gel on a 3MM Whatman paper and remove any air bubbles. Place Saran Wrap evenly on top of the gel without creating any bubbles. This helps to keep the gel intact and prevents any contamination to the gel dryer. Place the gel in a gel dryer for about 60 minutes at 60°C.
6. Expose the gel to X-ray film or a phosphor imaging screen. Scan the imaging screen on a storage phosphor imaging system.

## Section 9 Troubleshooting

Always confirm that the line voltage is correct for the DCode system.

### 9.1 Equipment

Problem	Cause	Solution
<b>Controller</b>		
No display with power on	Burned out fuse	Replace fuse located near power cord connection
Buffer not circulating	Buffer level too low	Add buffer to 'Fill' level
	Pump clogged, not working	Call Bio-Rad
Cannot preheat buffer	Buffer level too low	Add buffer to 'Fill' level
Long preheat time	Clear loading lid not on system	Place clear loading lid on system
Stir bar not functioning	Broken belt on stirrer	Replace belt
	Stir bar interferes with gel sandwiches	Maximum thickness of gel is 1.5 mm
	Stir bar not engaged	Align stir bar in support tank hole
<b>Casting gels</b>		
Leaking during gel casting	Improper assembly of gel sandwich	Using the alignment card, check that the spacers and glass plate bottom are flush prior to pouring gel
	Chipped glass plates	Insure glass plates are free of flaws. Use new set of glass plates

## 9.1 Equipment (continued)

<b>Problem</b>	<b>Cause</b>	<b>Solution</b>
<b>Perpendicular gradient (DGGE only)</b>		
Glass plate cracked	Excessive force at comb gasket	Apply only one turn to thumb gasket screw after it touches glass
Gel solution leaks during casting	Not sufficient pressure on comb gasket	Make sure pressure clamp screws are turned two turns
	Poor contact between comb gasket and spacers	Reassemble glass plates as in Section 4.1. Visually confirm contact at spacers and comb gasket
	Casting stand gasket positioned incorrectly	Position gray gasket so that it covers the entire bottom section of the glass plate
	Wrong comb gasket	Make sure correct comb gasket is used
	Misaligned comb gasket	Insure that comb gasket notches are against spacer notches
	Misaligned plates	Pressure clamp may force plates to shift if sandwich clamps are not tight. Insure that sandwich clamps are tightened
	Misalignment of spacers and glass plates	Check alignment at bottom of glass plates, using alignment slot on casting stand
	Damaged or dirty spacers and/or combs	Replace spacers or combs
	Different thickness of spacers and comb	Use spacers and comb of same thickness
	Dirty inlet fitting or missing O-ring	Replace fitting
Loose stopcock	Tighten stopcock/inlet port screw connection	
No air vent plug	Plug vent after casting gel	
Damaged or non-Bio-Rad glass plates	Replace with Bio-Rad glass plates only	



## 9.2 Applications

Problem	Solution
<b>Perpendicular DGGE</b>	
Only a single band is seen	Mix normal and mutant DNA samples prior to loading well
Difficult to visualize heteroduplex and homoduplex DNA bands	1. Increase amount of DNA (1–3 µg). 2. Use SYBR Green I dye agent (Molecular Probes, Inc.).
Unknown faint bands	Impurity or non-specificity of PCR product
Poor gradient	Insure that gradient delivery system is working properly. See instructions
“S” curve appears to be shifted/cut	1. Increase upper gradient concentrations. 2. Level tilt rod after gel is cast.
Smear at top of gel	Probably genomic DNA. This is OK
<b>Parallel DGGE</b>	
Normal and mutant course DNA unresolved	1. Increase or decrease run time (time run recommended). 2. Recalculate gradient range from perpendicular gel or run a time course gel.
Air bubbles in gel	Clean glass plates
Fuzzy DNA bands	Clean wells before use. Check for matching comb and spacer thickness. 2. Let gel polymerize for at least 60 minutes.
Bands did not migrate far enough into gel	1. Increase run time. 2. Decrease acrylamide concentration. 3. Decrease denaturant concentration.
DNA leaks between wells	1. Acrylamide not polymerized. Add more TEMED and ammonium persulfate to final concentration of 0.1%. 2. Degas acrylamide solution before casting gel. 3. Let gel polymerize for at least 60 minutes. 4. Do not overload sample well. Reduce sample volume.
Skewed or distorted bands, or DNA spikes in gel	1. Impurities in acrylamide. Filter before use. Check shelf life date of acrylamide. 2. Carefully load DNA into wells. Do not pierce or puncture wells.

## 9.2 Applications (continued)

Problem	Solution
<b>CDGE</b>	
Normal and mutant DNA unresolved	Recalculate constant denaturant from a perpendicular or parallel DGGE gel
Air bubbles in gel	Clean glass plates
Fuzzy DNA bands	<ol style="list-style-type: none"><li>1. Clean wells before use. Check for matching comb and spacer thickness.</li><li>2. Let gel polymerize for at least 60 minutes.</li></ol>
Bands did not migrate far enough into gel	<ol style="list-style-type: none"><li>1. Increase run time.</li><li>2. Re-check acrylamide concentration.</li><li>3. Re-check denaturant concentration.</li></ol>
DNA leaks between wells	<ol style="list-style-type: none"><li>1. Acrylamide not polymerized. Add more TEMED and ammonium persulfate to final concentration of 0.1%.</li><li>2. Degas acrylamide solution before casting gel.</li><li>3. Let gel polymerize for at least 60 minutes.</li><li>4. Do not overload sample well. Reduce sample volume.</li></ol>
Skewed or distorted bands, use or DNA spikes in gel	<ol style="list-style-type: none"><li>1. Impurities in acrylamide. Filter before use. Check shelf life date of acrylamide solution.</li><li>2. Carefully load DNA in wells. Do not pierce or puncture the wells.</li></ol>
<b>TTGE</b>	
Normal and mutant from DNA unresolved	<ol style="list-style-type: none"><li>1. Recalculate temperature gradient using MacMelt software.</li><li>2. Use a small temperature ramp rate (<math>rr = 1</math> or <math>2</math>).</li><li>3. For narrow temperature ranges (<math>&lt; 6^{\circ}\text{C}</math>), use a smaller ramp rate (<i>i.e.</i> <math>1^{\circ}\text{C/hr}</math>).</li><li>4. For large temperature ranges (<math>&gt; 9^{\circ}\text{C}</math>), use larger ramp rate (<i>i.e.</i> <math>3^{\circ}\text{C/hr}</math>).</li></ol>
Air bubbles in gel	Clean glass plates
Fuzzy DNA bands	<ol style="list-style-type: none"><li>1. Clean wells before use. Check for matching comb and spacer thickness.</li><li>2. Let gel polymerize for at least 60 minutes.</li></ol>
Bands did not migrate far enough into gel	<ol style="list-style-type: none"><li>1. Increase run time.</li><li>2. Decrease acrylamide concentration.</li><li>3. Increase temperature range and/or run at lower temperatures.</li></ol>

DNA leaks between wells

1. Acrylamide not polymerized. Add more TEMED and ammonium persulfate to final concentration of 0.1%.
2. Degas acrylamide solution before casting gel.
3. Let gel polymerize for at least 60 minutes.
4. Do not overload sample well. Reduce sample volume.

Skewed or distorted bands,  
use. or DNA spikes in gel

1. Impurities in acrylamide. Filter before use. Check shelf life date of acrylamide.
2. Carefully load DNA into wells. Do not pierce or puncture wells.

### **Heteroduplex Analysis**

Normal and mutant  
DNA unresolved

1. Optimize concentration of DEM.
2. Add 15% urea to gel.
3. Adjust voltage or run time so that samples travel at least 15 cm from well.

Air bubbles in gel

Clean glass plates

Fuzzy DNA bands

1. Clean wells before use. Check for matching comb and spacer thickness.
2. Let gel polymerize for at least 60 minutes.

Bands did not migrate far  
enough into gel

1. Increase run time.
2. Decrease acrylamide concentration.
3. Increase voltage.

DNA leaks between wells

1. Acrylamide not polymerized. Add more TEMED and ammonium persulfate to final concentration of 0.1%.
2. Degas acrylamide solution before casting gel.
3. Let gel polymerize for at least 60 minutes.
4. Do not overload sample well. Reduce sample volume.

Skewed or distorted bands,  
or DNA spikes in gel

1. Impurities in acrylamide. Filter before use. Check shelf life date of acrylamide.
2. Carefully load DNA in wells. Do not pierce or puncture the wells.

### **SSCP**

Normal and mutant  
DNA unresolved

1. Optimize running temperature.
2. Add 5–10% glycerol to gel.
3. Reduce crosslinking of acrylamide and bis.
4. Use different concentration of buffer.

Buffer temperature does not	<ol style="list-style-type: none"> <li>1. Use 50% ethylene glycol as chiller coolant. reach set temperature</li> <li>2. Insure that DCode temperature controller is set at desired buffer temperature.</li> <li>3. Check that chiller is set to <math>-20^{\circ}\text{C}</math>.</li> </ol>
Air bubbles in gel Fuzzy DNA bands	<p>Clean glass plates</p> <ol style="list-style-type: none"> <li>1. Clean wells before use. Check for matching comb and spacer thickness.</li> <li>2. Let gel polymerize for at least 60 minutes.</li> </ol>
Bands did not migrate far enough into gel	<ol style="list-style-type: none"> <li>1. Increase run time.</li> <li>2. Decrease acrylamide concentration.</li> <li>3. Increase voltage or power.</li> </ol>
DNA leaks between wells	<ol style="list-style-type: none"> <li>1. Acrylamide not polymerized. Add more TEMED and ammonium persulfate to final concentration of 0.1%.</li> <li>2. Degas acrylamide solution before casting gel.</li> <li>3. Let gel polymerize for at least 60 minutes.</li> <li>4. Do not overload sample well. Reduce sample volume.</li> </ol>
Skewed or distorted bands, or DNA spikes in gel	<ol style="list-style-type: none"> <li>1. Impurities in acrylamide. Filter before use. Check shelf life date of acrylamide.</li> <li>2. Carefully load DNA in wells. Do not pierce or puncture wells.</li> </ol>
<b>PTT</b>	
"Smile effect"–band pattern curves	<p>Decrease power setting, or fill lower chamber upward at both sides of gel with buffer up to the "Max" setting on tank</p>
Air bubbles in gel Fuzzy DNA bands	<p>Clean glass plates</p> <ol style="list-style-type: none"> <li>1. Clean wells before use. Check for matching comb thickness and spacer thickness.</li> <li>2. Let gel polymerize for at least 60 minutes.</li> </ol>
Bands did not migrate far enough into gel	<ol style="list-style-type: none"> <li>1. Increase run time.</li> <li>2. Decrease acrylamide concentration.</li> <li>3. Running buffer too concentrated. Check buffer protocol.</li> <li>4. Increase voltage or power.</li> </ol>
Skewed or distorted bands	<ol style="list-style-type: none"> <li>1. Acrylamide not polymerized. Add more TEMED and ammonium persulfate to final concentration of 0.1%.</li> <li>2. Degas acrylamide solution before casting gel.</li> <li>3. Let gel polymerize for at least 60 minutes.</li> </ol>

## Section 10 Specifications

### Construction

Tank, core and clamps	Tank: molded polycarbonate; Core: molded polysulfone; Clamps: molded glass-filled polycarbonate
Lid	Urethane or polycarbonate
Electrodes	0.010" diameter platinum
Electrical leads	Polyurethane, copper conductor
Casting stand	Able to cast two 16 x 20 cm, two 16 x 16 cm, two 16 x 10 cm or one 7.5 x 10 cm gels per setup simultaneously
Heater and control	Temperature control (PID type) $\pm 0.5^{\circ}\text{C}$ variation within gel area, $\pm 0.5^{\circ}\text{C}$ actual in the range of 45 to 70°C. Maximum set temperature 70.5°C
Electrophoresis cooling	Temperature control between 5°C–room temperature with recommended chillers. Minimum temperature 5°C (SSCP system only, external chiller required)
DC voltage limit	500 V DC
DC power limit	50 W
Gradient former	Cast acrylic and acetal (DGGE system only)
Glass plates	20 x 22 cm (20 cm format), 16 x 20 cm (16 cm format), 10.2 x 20 cm (10 cm format)
Gel sizes	16 x 20 cm (max. two per run), 16 x 16 cm (max. two per run), 16 x 10 cm (max. two per run), 7.5 x 10 cm (max. four per run)
Spacers available	0.75, 1.0 and 1.5 mm
Combs	16 well comb (compatible with 8 well multi-channel pipettor), 20 well comb, 25 well comb and 1 well comb (Prep comb for perpendicular gradient gels). Optional can use combs from PROTEAN® II xi system

### AC Power Requirements

170-9080/9083/9086/9089 170-9092/9095/9098/9102	AC power input: 120 VAC 47–63 Hz, 5 A slow blow fuse
170-9082/9085/9088/9091 170-9094/9097/9100/9104	AC power input: 100 VAC 47–63 Hz, 5 A slow blow fuse
170-9081/9084/9087/9090 170-9093/9096/9099/9103	AC power input: 220–240 VAC 47–63 Hz, 2.5 A slow blow fuse

### DC Power Requirements

External DC voltage power supply. This power supply must be ground isolated in such a way that the DC voltage output floats with respect to ground.

Maximum voltage limit	500 VDC
Maximum power limit	50 W

### Size and Weight

Overall size	Lid and tank assembly: 39 cm (L) x 20 cm (W) x 42 cm (H)
Shipping weight	16 Kg

### Environmental Requirements

Storage environment	0–70°C, humidity 0–95% (non-condensing)
Operating environment	0–35°C, humidity 0–95%

### Regulatory

Meets requirements of EN61010-1.

## Section 11 Maintenance

### Maintenance of Equipment

DCode system with lid	Remove core and clamps from tank. Replace assembly buffer inside tank with distilled water, turn pump on for 1–2 minutes to rinse pump. Remove water from tank.
Core, cell, clamps	Rinse thoroughly with distilled water after use.
Glass plates, spacers, combs	Wash with a laboratory detergent (catalog #161-0722) then rinse with distilled water.

Always inspect the DCode tank, cable, and whole system. Replace any damaged components before use. Damaged parts are to be repaired by Bio-Rad trained personnel with Bio-Rad approved components only.

The controller retains its tuning parameters in non-volatile memory for 10 years without power.

## Section 12 References

1. Orrita, M., Iwahana, H., Kanazawa, H., Hayashi, K., and Sekiya, T., *Proc. Natl. Acad. Sci.*, **86**, 2766–2770 (1989).
2. Fischer, S. and Lerman, L., *Proc. Natl. Acad. Sci.*, **80**, 1579–1583 (1983).
3. Ganguly, A. and Prockop, D., *Nucleic Acids Res.*, **18**, 3933–3939 (1990).
4. Cotton, R., Rodrigues, N., and Campbell, R., *Proc. Natl. Acad. Sci.*, **85**, 4397–4401 (1988).
5. Myers, R., Larin, Z., and Maniatis, T., *Science*, **230**, 1242–1246 (1985).
6. Nagamine, C., Chan, K., and Lau, Y., *Am. J. Hum. Genet.*, **45**, 337–339 (1989).
7. Roest, P., Roberts, R., Sugino, S., Van Ommen, G., and Den Dunnen, J., *Hum. Mol. Genet.*, **2**, 1719–1721 (1993).
8. Yoshino, K., Nishigaki, K., and Husimi, Y., *Nucleic Acids Res.*, **19**, 3153 (1991).
9. Myers, R., Maniatis, T., and Lerman, L., *Methods Enzymol.*, **155**, 501–527 (1987).
10. Costes, B., Girodon, E., Ghanem, N., Chassignol, M., Thuong, N., Dupret, D., and Goossens, M., *Hum. Mol. Genet.*, **2**, 393–397 (1993).
11. Smith-Sorensen, B., Hovig, E., Andersson, B., and Borresen, A., *Mutat. Res.*, **269**, 41–53 (1992).
12. Lerman, L., Fischer, S., Hurley, I., Silverstein, K., and Lumelsky, N., *Ann. Rev. Biophys. Bioeng.*, **13**, 399–423 (1984).
13. Hovig, E., Smith-Sorensen, B., Uitterlinden, A., and Borresen, A., *Pharmacogenetics*, **2**, 317–328 (1992).
14. Yoshino, K., Nishigaki, K., and Husimi, Y., *Nucl. Acids Res.*, **19**, 3153 (1991).
15. Wiese, U., Wulfert, M., Prusiner, S., B., and Riesner, D., *Electrophoresis*, **16**, 1851–1860 (1995).
16. White, M., Carvalho, M., Derse, D., O'Brien, S., and Dean, M., *Genomics*, **12**, 301–306 (1992).
17. Glavac, M., Glavac, D., and Dean, M., *Hum. Mol. Genet.*, **3**, 801–807 (1994).
18. Keen, J., Lester, D., Inglehearn, C., Curtis, A., and Bhattacharyya, S., *Trends Genet.*, **7**, 5 (1991).
19. Ganguly, A., Rock, M., and Prockop, D., *Proc. Natl. Acad. Sci.*, **90**, 10325–10329 (1993).
20. Williams, C., Rock, M., Considine, E., McCarron, S., Gow, P., Ladda, R., McLain, D., Michels, V., Murphy, W., Prockop, D., and Ganguly, A., *Hum. Mol. Genet.*, **4**, 309–312 (1995).
21. Laing, T., and Gatti, R., personal communication (1996).
22. Sekiya, T., Technologies for detection of DNA Damage and Mutations, chapter 21, Plenum Press, New York, 281–290 (1996).
23. Spinardi, L., Mazars, R., and Theillet, C., *Nucl. Acids Res.*, **19**, 4009 (1991).
24. Hongyo, T., Buzard, G., Calvert, R., and Weghorst, C., *Nucl. Acids Res.*, **21**, 3637–3642 (1993).
25. Cotton, R., *Mutat. Res.*, **285** (3), 813–826 (1992).
26. Glavac, D., and Dean, M., *Hum. Mutation*, **2**, 404–414 (1993).
27. Hayashi, K., Laboratory Protocols for Mutation Detection, Oxford University Press, 14–22 (1996).
28. Prosser, J., *Tibtech*, **11**, 238–247 (1993).
29. Grompe, M., *Nature Genetics*, **5**, 111–117 (1993).
30. Den Dunnen, J. T., Roest, P., Van Der Luijt, R., and Hogervorst, F., Technologies for Detection of DNA Damage and Mutations, edited by Gerd P. Pfeifer, Plenum Press 1996, p. 323–341.
31. Laemmli, U.K., *Nature*, **227**, 680–685 (1970).
32. Gelfi, C., Righetti, P., Cremonesi, L., and Ferrari, M., *Electrophoresis*, **15**, 1506–1511 (1994).
33. Steger, G., *Nucleic Acids Res.*, **22**, 2760–2768 (1994).
34. Myers, R., Fischer, S., Lerman, L., and Maniatis, T., *Nucl. Acids Res.*, **13**, 3131–3145 (1985).

## Section 13

### Systems, Accessories, and Reagents for Mutation Detection Electrophoresis

For complete ordering information for DCode accessories, electrophoresis reagents, and control kits, request bulletin 2100.

Catalog Number	Product Description
<b>DCode Universal Mutation Detection Systems</b>	
170-9080	<b>DCode System for DGGE, 16 cm</b> , 120 V, includes electrophoresis/temperature control module, sandwich core, DGGE kit for 16 cm gel casting (2 sets of plates, 2 sets of clamps and 1 mm spacers, two 1 mm one well prep combs, comb gasket), all parts required to cast gradient gels, Model 475 Gradient Former, control reagents for DGGE
170-9081	<b>DCode System for DGGE, 16 cm</b> , 220/240 V
170-9082	<b>DCode System for DGGE, 16 cm</b> , 100 V
170-9083	<b>DCode System for DGGE, 10 cm</b> , 120 V, includes electrophoresis/temperature control module, sandwich core, DGGE kit for 10 cm gel casting (2 sets of plates, 2 sets of clamps and 1 mm spacers, two 2-well 1 mm prep combs, comb gasket), all parts required to cast gradient gels, Model 475 Gradient Former, control reagents for DGGE
170-9084	<b>DCode System for DGGE, 10 cm</b> , 220/240 V
170-9085	<b>DCode System for DGGE, 10 cm</b> , 100 V
170-9086	<b>DCode System for CDGE</b> , 120 V, includes electrophoresis/temperature control module, sandwich core, CDGE kit for 16 cm gel casting (2 sets of 16 cm plates, 2 sets of 1 mm spacers, two 20-well 1 mm combs), control reagents for CDGE
170-9087	<b>DCode System for CDGE</b> , 220/240 V
170-9088	<b>DCode System for CDGE</b> , 100 V
170-9089	<b>DCode System for TTGE</b> , 120 V, includes electrophoresis/temperature control module, sandwich core, TTGE kit for 16 cm gel casting (2 sets of 16 cm plates, 2 sets of 1 mm spacers, two 20-well 1 mm combs), control reagents for TTGE
170-9090	<b>DCode System for TTGE</b> 220/240 V
170-9091	<b>DCode System for TTGE</b> 100 V
170-9092	<b>DCode System for SSCP</b> , 120 V, includes electrophoresis temperature control module, sandwich core, SSCP kit for gel casting (2 sets of 20 cm plates, 2 sets 0.75 mm spacers, two 20-well 0.75 mm thick combs), electrophoresis cooling tank for use with external cooling bath, control reagents for SSCP
170-9093	<b>DCode System for SSCP</b> , 220/240 V
170-9094	<b>DCode System for SSCP</b> , 100 V
170-9095	<b>DCode System for Heteroduplex Analysis</b> , 120 V, includes electrophoresis/temperature control module, sandwich core, heteroduplex kit for gel casting (2 sets of 20 cm plates, 2 sets of 0.75 mm spacers, two 20-well 0.75 mm thick combs), control reagents for heteroduplex analysis
170-9096	<b>DCode System for Heteroduplex Analysis</b> , 220/240 V

<b>Catalog Number</b>	<b>Product Description</b>
170-9097	<b>DCode System for Heteroduplex Analysis, 100 V</b>
170-9098	<b>DCode System for PTT, 120 V</b> , includes electrophoresis/temperature control module, sandwich core, PTT kit for gel casting (2 sets of 20 cm plates, 2 sets of 1 mm spacers, two 20-well 1 mm thick combs)
170-9099	<b>DCode System for PTT, 220/240 V</b>
170-9100	<b>DCode System for PTT, 100 V</b>
170-9102	<b>Complete DCode System, 120 V</b> , includes electrophoresis/temperature control module with cooling tank, sandwich core, Model 475 Gradient Former with all accessories required to cast gradient gels, MacMelt software, control reagents for DGGE/CDGE/TTGE, SSCP, PTT, and HA, plates, combs and spacers to cast 1 mm and 0.75 mm thick 10, 16 and 20 cm gels.
170-9103	<b>Complete DCode System, 220/240 V</b>
170-9104	<b>Complete DCode System, 100 V</b>

## **DCode Accessories**

170-9125	<b>DGGE Kit, 16 cm</b> , includes 2 sets of 16 cm plates, 2 sets of 1 mm spacers, two 1-well 1 mm prep combs, sandwich clamps, pressure clamp, comb gasket and holder, fittings required for gradient gel casting
170-9126	<b>DGGE Kit, 10 cm</b> , includes 2 sets of 10 cm plates, 2 sets of 1 mm spacers, two 2-well 1 mm prep combs, sandwich clamps, pressure clamp, comb gasket and holder, fittings required for gradient gel casting
170-9127	<b>CDGE /TTGE Kit</b> , includes 2 sets of 16 cm plates, 2 sets of 1 mm spacers, two 20-well 1 mm combs, sandwich clamps
170-9128	<b>Complete SSCP Kit</b> , includes electrophoresis cooling tank for use with external chiller, 2 sets of 20 cm plates, 2 sets of 0.75 mm spacers, two 20-well 0.75 mm combs, sandwich clamps
170-9129	<b>Basic SSCP Kit</b> , 2 sets of 20 cm plates, 2 sets of 0.75 mm spacers, two 20-well 0.75 mm combs, sandwich clamps
170-9130	<b>Heteroduplex Kit</b> , 2 sets of 20 cm plates, 2 sets of 0.75 mm spacers, two 20-well 0.75 mm combs, sandwich clamps
170-9131	<b>PTT Kit</b> , 2 sets of 20 cm plates, 2 sets of 1 mm spacers, two 25-well 1 mm thick combs, sandwich clamps
170-9034	<b>MacMelt Software</b>
170-9042	<b>Model 475 Gradient Former</b> , includes cam-operated manual gradient former, 2 each of 10 and 30 ml syringes, and all accessories required to cast gradient gels
170-9140	<b>Electrophoresis Cooling Tank</b> , for use with external laboratory recirculating chiller



## DCode Control and Electrophoresis Reagents

- 170-9150 **DCode Control Reagent Kit for DGGE/CDGE/TTGE**, includes primers (one GC-clamped) and DNA templates for production of wild-type and mutant DNA
- 170-9151 **DCode Control Reagent Kit for SSCP**, includes primers and DNA templates for production of wild-type and mutant DNA
- 170-9152 **DCode Control Reagent Kit for heteroduplex analysis**, includes homoduplex and heteroduplex DNA in 1x loading buffer
- 170-9170 **DCode Electrophoresis Reagent Kit for DGGE/CDGE**, includes 500 ml 40% acrylamide/bis solution(37.5:1), 250 g urea, 225 ml 100% formamide (deionized), 2 x 1 liter 50x TAE buffer, 10 ml of 10 mg/ml EtBr, 1 ml of 2x gel loading dye, 10 ml DCode dye solution, 5 ml TEMED, 10 g ammonium persulfate
- 170-9171 **DCode Electrophoresis Reagent Kit TTGE**, includes 500 ml 40% acrylamide/bis solution(37.5:1), 1 kg urea, 2 x 1 liter 50x TAE buffer, 10 ml of 10mg/ml EtBr, 1 ml of 2x Gel loading dye, 5 ml TEMED, 10 g ammonium persulfate
- 170-9172 **DCode Electrophoresis Reagent Kit for SSCP**, includes 500 ml 40% acrylamide solution, 500 ml 2% bis solution, 100 ml of glycerol, 6 x 1 liter 10x TBE buffer, 2x SSCP gel loading dye, 5 ml TEMED, 10 g ammonium persulfate
- 170-9173 **DCode Electrophoresis Reagent Kit for Heteroduplex Analysis**, includes 250 ml 2x DEM solution, 250 g urea, 6 x 1 liter 10x TBE, 2x gel loading dye, 10 ml of 10 mg/ml EtBr solution, 5 ml TEMED, 10 g ammonium persulfate
- 170-9174 **DCode Electrophoresis Reagent Kit for PTT**, includes 500 ml 40% acrylamide/bis (37.5:1), 2 x 1 liter 10x Tris/Glycine/SDS buffer, 30 ml Laemmli sample buffer, 500 g Tris base, 25 ml 2-mercaptoethanol, 250 ml 10% SDS, 10 g ammonium persulfate, 5 ml TEMED







**Bio-Rad  
Laboratories, Inc.**

Life Science  
Group

---

**Web site** [www.bio-rad.com](http://www.bio-rad.com) **USA** 800 4BIORAD **Australia** 61 02 9914 2800 **Austria** 01 877 89 01 **Belgium** 09 385 55 11 **Brazil** 55 21 3237 9400  
**Canada** 905 364 3435 **China** 86 21 6426 0808 **Czech Republic** 420 241 430 532 **Denmark** 44 52 10 00 **Finland** 09 804 22 00 **France** 01 47 95 69 65  
**Germany** 089 318 84 0 **Greece** 30 210 777 4396 **Hong Kong** 852 2789 3300 **Hungary** 36 1 455 8800 **India** 91 124 4029300 **Israel** 03 963 6050  
**Italy** 39 02 216091 **Japan** 03 6361 7000 **Korea** 82 2 3473 4460 **Mexico** 52 555 488 7670 **The Netherlands** 0318 540666 **New Zealand** 0508 805 500  
**Norway** 23 38 41 30 **Poland** 48 22 331 99 99 **Portugal** 351 21 472 7700 **Russia** 7 495 721 14 04 **Singapore** 65 6415 3188 **South Africa** 27 861 246 723  
**Spain** 34 91 590 5200 **Sweden** 08 555 12700 **Switzerland** 061 717 95 55 **Taiwan** 886 2 2578 7189 **United Kingdom** 020 8328 2000

---

Sig 0308

M1709080 Rev D