

Implementing Laser Scanned-MEMS Projection in Automotive Head-Up Displays

Introduction

In 1988, the Oldsmobile Cutlass Supreme became the first production car with a basic head-up display, also known as HUD. Automotive safety was and continues to be the main driving force for the deployment of HUDs with the aim of preventing drivers from taking their eyes off the road to look down and read their dashboard instruments. Distracted driver studies have shown that taking your eyes off the road for more than two seconds doubles your risk of a crash. Over the last decade, HUDs have become more sophisticated and increasingly available as standard or optional equipment in luxury car models from several automakers. They represent the latest safety innovation, and have become part of an ever-increasing suite of advanced driver assistance systems (ADAS).

The automotive HUD places key information such as speed, warning signals, and indicator arrows on the windshield directly in front of the driver's line of sight. One of the latest laser scanned-MEMS projection systems uses laser diode drivers to pulse high intensity red, green and blue (RGB) lasers that project high-definition (HD) video onto the windshield (see Figure 1). These new real-time laser systems enable HUD information with virtually zero latency. Augmented reality HUDs appear to paint a transparent arrow directly onto the street in front of the car, making color turning signals and navigation directions easy to follow. They also highlight other objects, like pedestrians or vehicles that might present a hazard and brings them to the driver's attention.

This white paper looks at the history of optical MEMS systems and shows how the technical merits of a laser scanned-MEMS projection system provide a superior, lower-cost solution than liquid-crystal display (LCD) and digital light processing (DLP) HUDs. We'll also examine a high-speed, quad-channel laser diode driver that provides a complete solution for driving high intensity lasers in laser scanned-MEMS projection systems designed for next-generation automobiles.

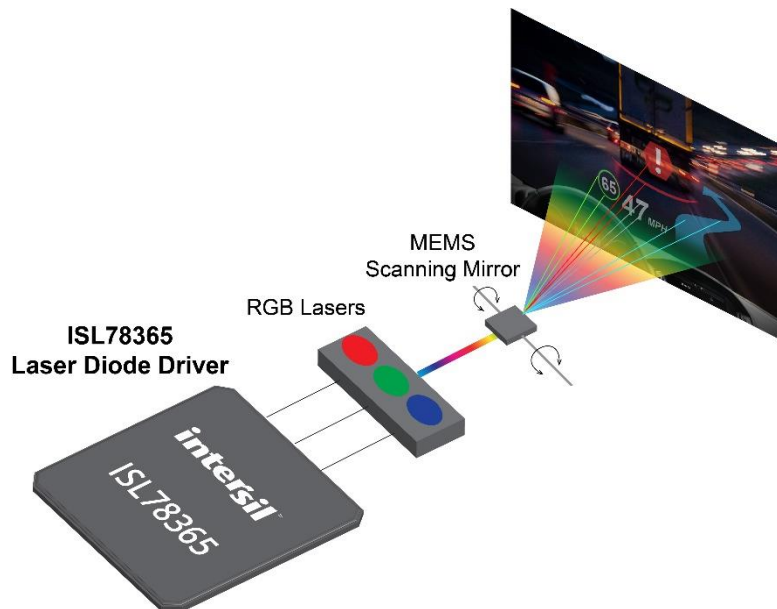

Figure 1. Laser scanned-MEMS projection system for automotive head-up display

Optical MEMS: A Brief History

Optical MEMS has been around since the early 1980s with the first patent filed by Texas Instruments for the deformable mirror light modulator. Since then, one of the major applications for MEMS mirrors has been in the display market. Every time we enjoy a movie at the digital cinema theater, we see this technology at work.

Since their introduction, the physical size of MEMS projection systems has experienced several transformations. System size has shrunk from the large cinematic projector to the office projector and more recently, the palm size pocket-projector. This change came about due to advances in electronics integration, ultra-small IC packaging, and light source advancements. All of these innovations enable products with integrated projection displays such as Microvision's PicoP, Samsung's Galaxy smartphone, Lenovo's Yoga tablet, and now automobiles with HUDs using laser scanning MEMS technology.

For a brief time, DLP systems dominated the large-screen, rear-projection display market, but DLPs dominance met tough new competition with the introduction of flat panel thin-film-transistor (TFT) displays. Similarly, the use of DLP-based HUDs in the automotive market is now facing stiff competition from the maturing and availability of single-pixel scanning MEMS projection displays. The key factors that give scanned-MEMS such a boost are the wide availability of laser diodes, higher integration of electronics, and lower cost optics.

Previously, RGB laser diodes had been cost-prohibitive to the adoption of laser scanned-MEMS projection. Today, with several manufacturers such as OSRAM, Nichia, Cree, Panasonic, Philips and others, the cost of laser diodes has been reduced to an acceptable level for automakers. In addition, some of these manufactures are making automotive-grade AEC-Q100 certified laser diodes. And these RGB laser diodes are now integrated into a monolithic module where the beam alignment is handled during module manufacturing, making it much easier for system designers to integrate the module into their HUD design.

Until now, most MEMS mirror manufacturers used a mature ASIC design that performs the driving function for their MEMS. However, to interface with the laser diode, HUD designers had to rely on discrete components. Each color channel required its own discrete laser driver, resulting in a rather large PCB surface area. This made the board design and thermal management more challenging for the system designer. But with the recent introduction of a quad-channel automotive-grade laser diode driver capable of full-HD pixel rates, it is now possible to pack the entire system into a small, compact area.

Comparing Laser Scanned-MEMS Projection with LCD and DLP

The LCD display panel is probably the most commonly used technology in today's automotive HUD systems. It employs a transmissive display technology and LED backlights that illuminate the entire image when light passes through it. With LCD HUDs, the image is first loaded into the LCD and is then illuminated by high power LEDs. The illuminated image is magnified, reflected off a fold mirror and focused onto the windshield in front of the driver's field of view.

The LCD HUD's dark pixels are created by blocking the backlight, which makes the LCD less transmissive for those pixels. However, not all light can be completely blocked, especially in low ambient light settings. The result is a projected image overlaid onto the windshield that looks like a transparent postcard sized rectangle (see Figure 2). Automakers see this as a major safety drawback of today's LCD HUD systems because the illuminated rectangle is a distraction to the driver.

Today's LCD-based HUDs have a limited field of view, and the LCD panel has limited resolution, which makes it harder to provide more information for the driver to see. For an increased field of view, a larger LCD panel would be required. Finally, to meet the augmented reality requirement, the HUD would need to have much higher resolution. Both the increased panel size and higher resolution present an additional design

challenge: more electrical power (greater than 80W) is required to light the panel. This is moving in the reverse direction of the automaker's goal to reduce power consumption and size, and to implement augmented reality safety advancements. Thus, the LCD is not a viable technology for next generation HUDs.



Figure 2. LCD HUD example

DLP, the other competing HUD technology, is similar to LCDs but offers better resolution. DLP has thousands of micromirrors arranged in a two-dimension (2D) array. Each mirror in the 2D array serves as a pixel, and each mirror is modulated to reflect the incident light to create the desired pixel intensity. A 100% bright pixel will have zero modulation, while a dark pixel will have the mirror set to reflect the light out of the imaging path. To give a uniform image result, the incident light source is collected and focused onto the 2D array, with equal intensity on each pixel. The reflected image is then magnified, refocused and projected to a folding mirror, and then onto the windshield, a process similar to the LCD HUD implementation.

DLP is a rectangular panel that requires a flat horizontal surface to project information. Windshields are relatively flat in the vertical direction, but not in the horizontal direction. Therefore, for DLP to place information onto the windshield, aspherical optics is required to accommodate the windshield's curves, which requires increasing the size of the HUD system solution.

DLP HUDs also employ LEDs as their primary illumination light source. Because LEDs are a lambertian light source, designers use specialty optics to optimize light efficiency and uniformly radiate each pixel with equal intensity to best fit the Etendue of the DLP panel. While DLP has less optical power loss when compared to transmissive LCDs, the LEDs employed still consume a significant amount of electrical power.

Compared to DLP systems, a laser scanned-MEMS projection system takes advantage of the scanning mirror's deformed image, enabling the use of lower cost optics to reduce the system's opto-mechanical cost. The main components of a laser scanned-MEMS system are the laser diodes, some small beam shaping and alignment optics designed to gather the different color beams into uniform shaped single beam, and the oscillating MEMS mirror and its control electronics. The color laser diodes are pulsed synchronously as the mirror is scanned across the display field. The image is then drawn pixel-by-pixel across the display field, which is overlaid onto the windshield.

In a laser scanned-MEMS projector, each pixel is pulsed very rapidly to create the full HD resolution. And, because the laser beam is always in focus, the image can be projected into the windshield without requiring

refocusing optics. This greatly reduces the overall optical system complexity and size, and it eliminates costly optical components and assembly.

Laser scanned-MEMS projection systems offer better overall electrical efficiency than LCD or DLP frame-based projection systems. Unlike a front projector where the entire display is filled with a presentation, the automotive HUD's navigation information and instrument information do not fill the entire HUD field display area. The HUD system presents only time-sensitive information on the windshield for a short duration of time. The augmented reality information is comprised of an image that can have over 70% of the display pixels turned off. Figures 3A and 3B show examples of HUD information. The red boxes in Figures 3A and 3B show typical HUD display areas where the projection system must be able to present the navigation information. Note the amount of pixels turned ON relative to the amount turned OFF in each example. Depending on the information, that ratio (ON:OFF pixels) can range anywhere from 1:3 to 1:6.



Figure 3A. Typical HUD output example



Figure 3B. HUD information example

For example, in the DLP frame-based display technology, regardless of how many pixels are turned ON, the light source must fill the entire pixel array. In Figure 3A, the light for “dark” or not turned on pixels in the red box display area is generated and then discarded either by reflecting it away from the area of view or by blocking it. This is energy consumed that counts against the HUD’s system efficiency. Even worse is that this lost energy contributes to additional heat generated by absorption of the redirected light and the cost of electrical energy to create the light in the first place. These two factors ultimately increase the frame-based thermal cooling requirement and electrical energy needs.

A laser scanned-MEMS HUD consumes electrical power when there are relevant pixels to be projected. With the typical navigation and instrumentation information as shown in Figures 3A and 3B, most of the electrical energy is consumed when there is a need to put a pixel onto the display. This dramatically reduces the electrical requirement, resulting in lower thermal profile and thus smaller thermal dissipation requirements. All of this, combined with the integration of driver electronics, results in an overall smaller projection footprint when compared to a frame-based HUD system.

With pixels turned off, the laser scanned-MEMS HUD does not create a postcard effect because only the pixels with information are illuminated. Where no information is presented, no light is projected and no power is wasted. Combined with the deformation mirror effect and the more compact size, the laser scanned-MEMS HUD is best suited for the next generation of augmented reality HUD systems.

High-Speed, Quad-Channel Laser Diode Driver

The ISL78365 laser diode driver is the first four-channel driver optimized for HD laser scanned-MEMS projection systems that help deliver augmented reality video information to the automobile windshield. The laser driver includes an interface that easily integrates with the MEMS ASIC to create a compact laser scanning projection system, as shown in Figure 4.

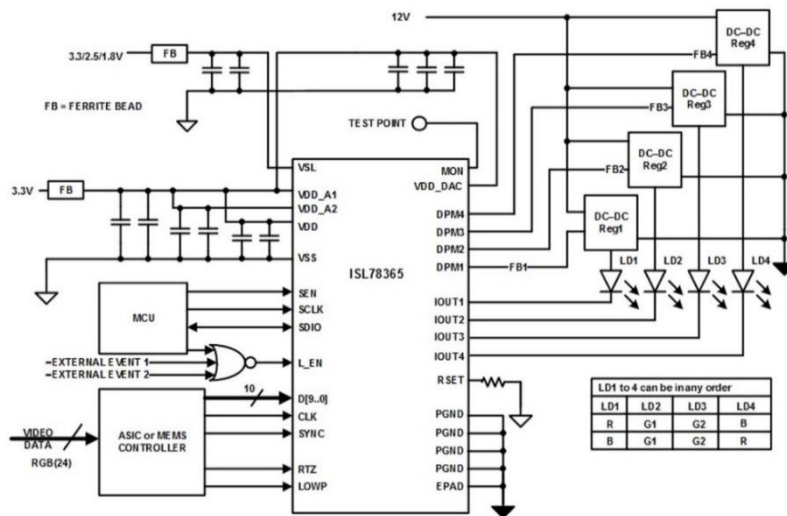

Figure 4. ISL78365 quad-channel laser driver pulsing four high-intensity laser diodes

The ISL78365 provides four high-speed 750mA programmable current sinks, which regulate the current and optical output of up to four laser diodes. It provides 1.5ns rise and fall times, resulting in high frame rate, HD color video, as illustrated in Figure 5. The laser driver offers independent color, threshold, and scale settings for each current sink, and its flexible high-speed parallel video interface supports full-HD projection and pixel rates up to 150MHz or 1900 pixels per line. It includes multiplexing of pixel data to simplify the opto-mechanical to electronic layout requirement.



Figure 5. Laser head-up display presents full-HD video information in car driver's line of sight

Dynamic power management for each laser diode supply and three power saving modes further reduce total system power consumption during blanking time. The laser driver's programmable return-to-zero pulsing functionality de-speckles the displayed image, and a programmable over-temperature protection enables customized thermal performance of the laser diodes. The ISL78365 is the first AEC-Q100 Grade-1 qualified laser driver, and is packaged in a wettable flank QFN package, making it easier for automakers to integrate into their system and manufacturing process.

Most RGB image processors have the color data image processed in the R, G, and B order. Thus, data presented to the MEMS laser driver is also in that order. This presents a design challenge because maintaining the optical laser-diode-illumination module in the same order can result in opto-mechanical compromises that result in lower lumens output, or a larger laser illuminator, or having to add additional laser diodes to compensate for the lower lumens. The ISL78365 data input interface overcomes this issue with its integrated multiplexer bus that simplifies the complex routing of the RGB data bus to the illuminator's opto-mechanical module.

Driving a good quality image requires control of the current pulse to the laser diode. Ideally, the waveform should be a square wave with an infinitely fast rising and falling edge, and a flat top during the pulse period. Such an ideal waveform does not exist in practice. With some laser diode drivers, fast transition pulses result in overshooting the rising edge of the drive current. The large overshoot exhibits itself in a pixel with a slightly brighter edge. If every pixel on an image has a slight bright edge, it produces undesirable image quality not suitable for the automotive laser HUD.

The ISL78365 provides adjustments to help compensate for this overshoot. Two compensations are possible: one to compensate for the overshoot, and another to compensate for pulse flatness. Figure 6 shows a 20ns pulse, and while most HD resolution displays do not have a 20ns pixel duration, we have chosen this pulse width to demonstrate the ISL78365's ability to compensate for pulse flatness. Because the overshoot is a function of the laser diode and the PCB parasitic, each driver channel has its own adjustment circuit, allowing the system designer to better tune to the different laser diode performances and picture qualities.

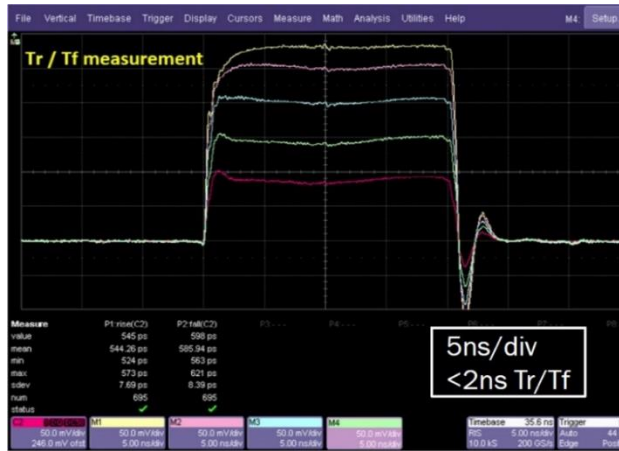

Figure 6. ISL78365 laser diode driver showing overshoot compensated pulse

Heat is another enemy of the HUD system. Excessive HUD system heat can damage the laser diodes and, therefore, a larger thermal heatsink is required to protect the lasers. However, a large heatsink means a larger cavity is required behind the dashboard, and that adds weight and more cost to the vehicle—all contradictory to the automaker’s goal of a lighter and greener vehicle. The ISL78365 offers dynamic power management to minimize excess power dissipation by optimizing the supplies for the laser diodes.

The ISL78365 also takes advantage of the need to place the laser diodes close to the driver itself, in order to offer thermal protection for the laser diodes. This placement minimizes parasitic inductance and capacitance on the current drive. An added benefit of placing the diodes near the laser driver is that it results in a close thermal coupling between the ISL78365 IC and the laser diodes. Therefore, using a fixed temperature offset, the ISL78365’s temperature will be close to that of the laser diode. And since the system can monitor the temperature of the laser diode driver, it will know the approximate temperature of the laser diodes.

The ISL78365 offers an integrated temperature monitor that is internally digitized, recording the die temperature in an internal register. There is also a programmable over-temperature shutdown point, as well as a programmable recovery temperature. By programming these registers, the system not only protects the ISL78365 from overheating but also the laser diode. Since the laser diode operating temperature range and lifetime vary from vendor to vendor, and are improving over time, the ISL78365’s programmable over-temperature feature allows it to be customized to protect any laser diode.

Conclusion

The laser scanned-MEMS projection system is better suited for automotive augmented reality HUDs than the alternative DLP or LCD frame-based display systems. It has the lowest thermal heat generation, and when a laser HUD scanned image only has 25% to 30% of its pixels turned on, the DLP and LCD HUD will require 100% of its image pixels driven to generate the same amount of brightness (current) as the laser HUD. DLP and LCD systems throw away light in order to display a black pixel, but with the laser scanned-MEMS projection system, a black pixel is truly black because the laser diode is turned off and is not consuming power or generating thermal heat.

The DLP and LCD optical architectures do not fully turn off a black pixel, so there is some level of leakage due to the display panel’s surface reflectivity. This results in a slight bright spot where the black pixels area should be. During daytime sunlight, this envelope might not be an issue, but at night, it is much more

apparent. From a driver safety perspective, it becomes another distraction, and tips the scale in favor of automakers moving to the laser scanned-MEMS projection system for their next generation HUD.

Next Steps

- [Learn more about the ISL78365](#)
- [Get the data sheet](#)
- [Watch a demo video](#)

#

About Renesas Electronics Corporation

Renesas Electronics Corporation delivers trusted embedded design innovation with complete semiconductor solutions that enable billions of connected, intelligent devices to enhance the way people work and live—securely and safely. A global leader in microcontrollers, analog, power, and SoC products, Renesas provides the expertise, quality, and comprehensive solutions for a broad range of Automotive, Industrial, Home Electronics, Office Automation and Information Communication Technology applications to help shape a limitless future. Learn more at [renesas.com](https://www.renesas.com)

+1 408-432-8888 | © Renesas Electronics America. All rights reserved. Renesas & Intersil (and design) are trademarks owned by Renesas Electronics Corporation or one of its subsidiaries. All other trademarks mentioned are the property of their respective owners.