



American Standards, Configurations, and Ratings: Introduction to Motor Circuit Design

Topic	Page
Summary of Changes	2
Introduction to American Standards	3
Motors	6
Introduction	6
Selection Process	6
Motor Circuit Conductors	11
Wire Size	12
Single Motor Conductor Sizing	13
Wye-Delta Configurations	14
Multi-speed Motors	15
Feeder Conductor Sizing	16
Motor Overload Protection	17
Introduction	17
Types of Overload Protection	17
Basic Sizing Requirements	18
Short-Circuit and Ground Fault Protection of Motor Branch Circuits	19
Introduction	19
Single Motor Applications	20
Multi-Motor Applications	22
Short-Circuit Protection of Motor Feeders	24
Introduction	24
Sizing the Motor Feeder Protective Device (Maximum)	24
Motor Controller	27
Introduction	27
Controller Requirements	27
Motor Control Circuits	31
Introduction	31
Transformers	32
Motor Disconnecting Means	34
Introduction	34
General Considerations	34
Adjustable-speed Drive Systems	36
Introduction	36
Drive Requirements	36

Topic	Page
Symbology	38
IEC and NEMA Comparison	38
Motor Power Circuit Calculation Examples	46
Introduction	46
Example 1 – Feeder Conductor Sizing	46
Example 2 – Standard Short-Circuit Protection	47
Example 3 – Exception for when maximum circuit protection sizing is insufficient for starting the motor	49
Glossary	51

Summary of Changes

This publication contains the following new or updated information. This list includes substantive updates only and is not intended to reflect all changes.

Topic	Page
Updated to apply to motor circuits and equipment < 1000V	throughout

Important User Information

Solid-state equipment has operational characteristics differing from those of electromechanical equipment. Safety Guidelines for the Application, Installation and Maintenance of Solid State Controls (publication [SGI-1.1](#) available from your local Rockwell Automation sales office or online at rok.auto/literature) describes some important differences between solid-state equipment and hard-wired electromechanical devices. Because of this difference, and also because of the wide variety of uses for solid-state equipment, all persons responsible for applying this equipment must satisfy themselves that each intended application of this equipment is acceptable.

In no event will Rockwell Automation, Inc. be responsible or liable for indirect or consequential damages resulting from the use or application of this equipment.

The examples and diagrams in this manual are included solely for illustrative purposes. Because of the many variables and requirements associated with any particular installation, Rockwell Automation, Inc. cannot assume responsibility or liability for actual use based on the examples and diagrams.

No patent liability is assumed by Rockwell Automation, Inc. with respect to use of information, circuits, equipment, or software described in this manual.

Reproduction of the contents of this manual, in whole or in part, without written permission of Rockwell Automation, Inc., is prohibited.

OEMs or panel builders, especially those who serve global markets, are challenged to meet the requirements of local codes and standards. This can be a daunting task when you consider differences in power systems, voltages, and frequencies. Although electrical codes may focus on the installation of equipment in a facility and contractors rely on these codes, they also affect all areas of the industrial machine from specification to design to building to operation.

There are several standards that address this issue in the United States, but the main ones are the National Electrical Code® (*NEC*) and UL 508A: Industrial Control Panels (UL 508A). Both have similar design requirements for motor circuits.

In the United States, the *NEC* exists to guide electricians in the proper installation of electrical equipment and defines the specific requirements for circuit protection. The primary focus of the *NEC* is fire prevention.

NFPA 79 is the electrical standard for industrial machinery and is closely harmonized with IEC 60204-1. It is intended to be used by specifiers, end users, panel builders, system integrators, contractors, and other qualified persons.

UL 508A is the design standard for safety for Industrial Control panels that are intended for construction of Listed panels that are built by panel builders. It is meant to apply to general use panels of less than 1000V, and requires compliance with *NEC* installation standards.

Designing equipment that complies with these standards helps to ensure that equipment is designed, properly installed, and used in a safe manner.

This application guide is intended to provide an overview of American motor circuit design based on methods that are outlined in the *NEC*. Examples provided are intended to illustrate typical applications and do not cover every exception.

Figure 1 - Scope of American Standards

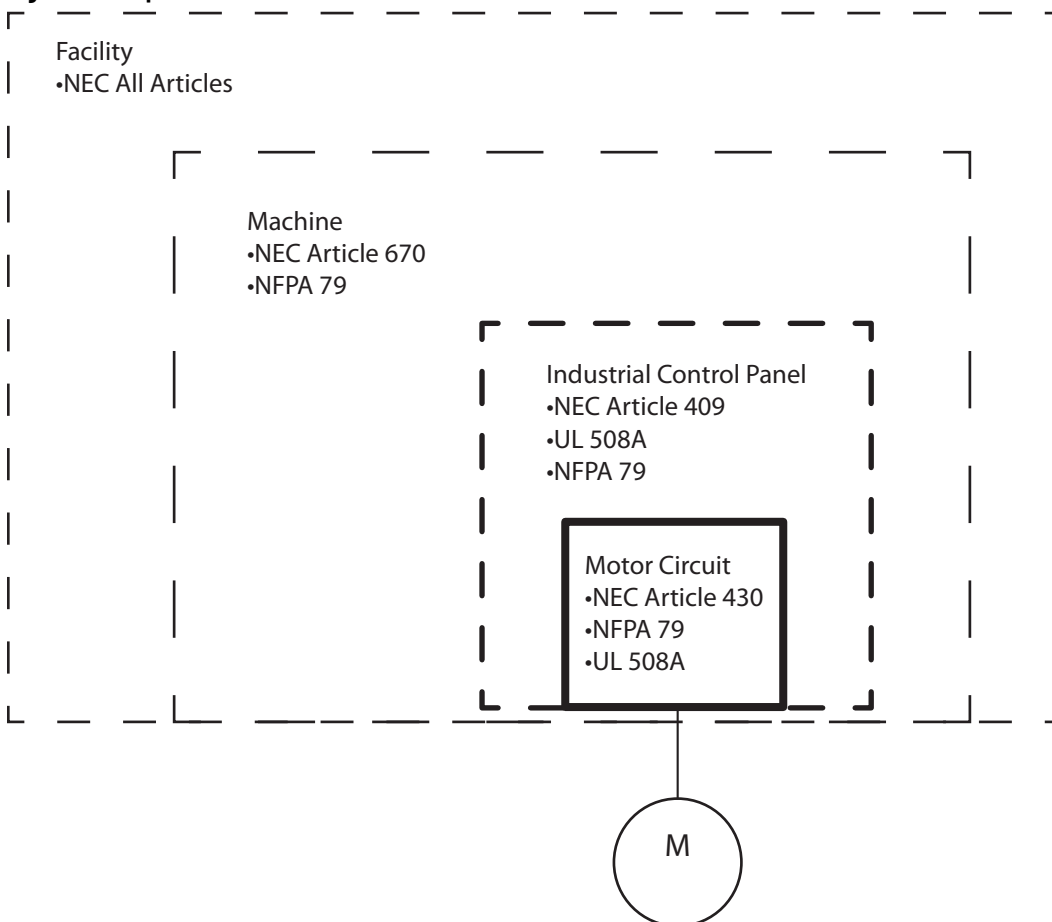

Industrial Control Panels

Industrial control panels discussed here fall within the same scope and definition as defined in the *NEC* and UL508A standard of safety for Industrial Control Panels. These panels are intended for general use and for operating at voltages no greater than 1000V.

NEC Article 409 defines the installation and construction requirements of industrial control panels. An industrial control panel can consist of only power components, only control circuit components, or a combination of the two. The requirement to provide an overcurrent protection either ahead or within the panel, as well as a disconnecting means is defined in this section.

The enclosure type requires that the enclosure rating is suitable for the environmental conditions. Construction requirements also include the size of the supply conductors, and wiring spacing.

Figure 2 - Conductor and Marking Requirements for Industrial Control Panel Supply

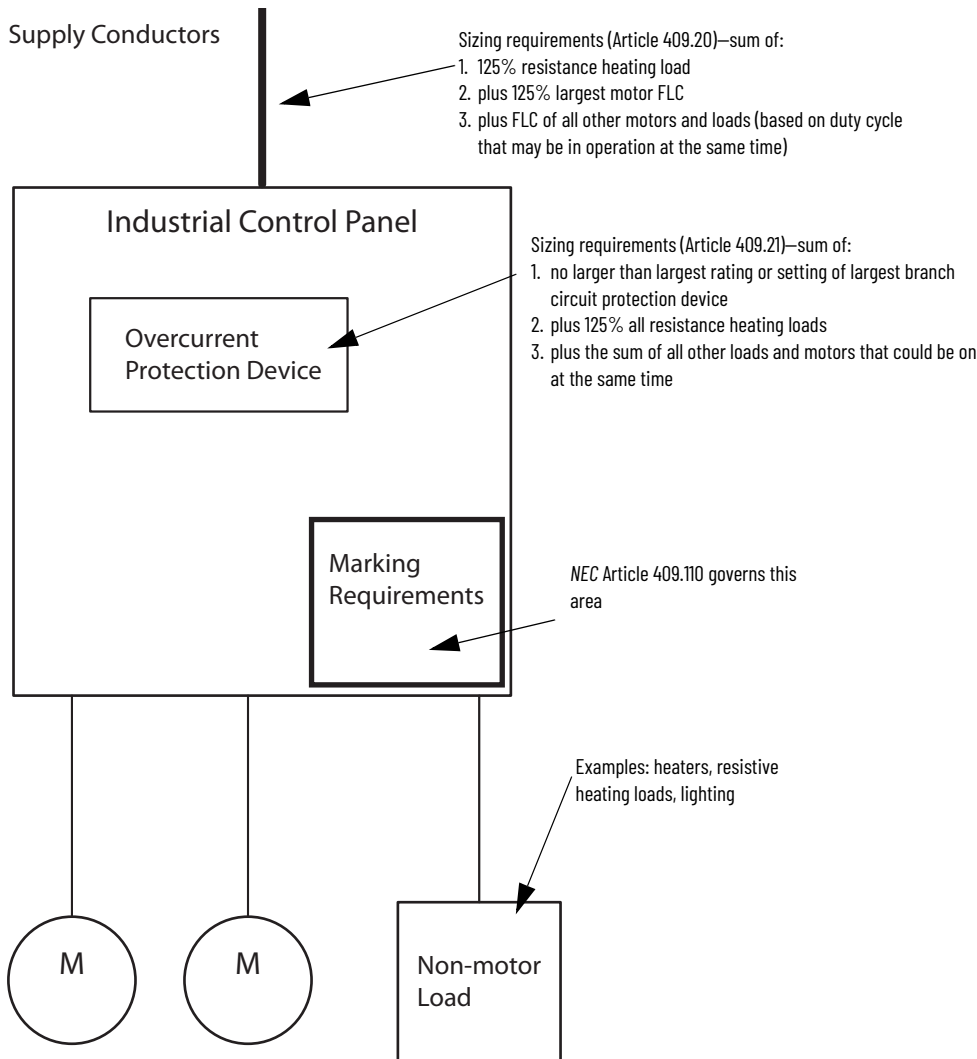

Motors, Motor Circuits, and Controllers

Within the *NEC*, Article 430 addresses motors, motor circuits, and controllers.

[Figure 3](#) shows the ten parts into which *NEC* Article 430 is divided. When you size circuit components, it is important to address each part in order. Doing so helps to minimize errors and standards compliance issues.

We discuss the aspects of *NEC* Article 430 in greater details in later chapters.

Figure 3 - NEC Article 430 Contents

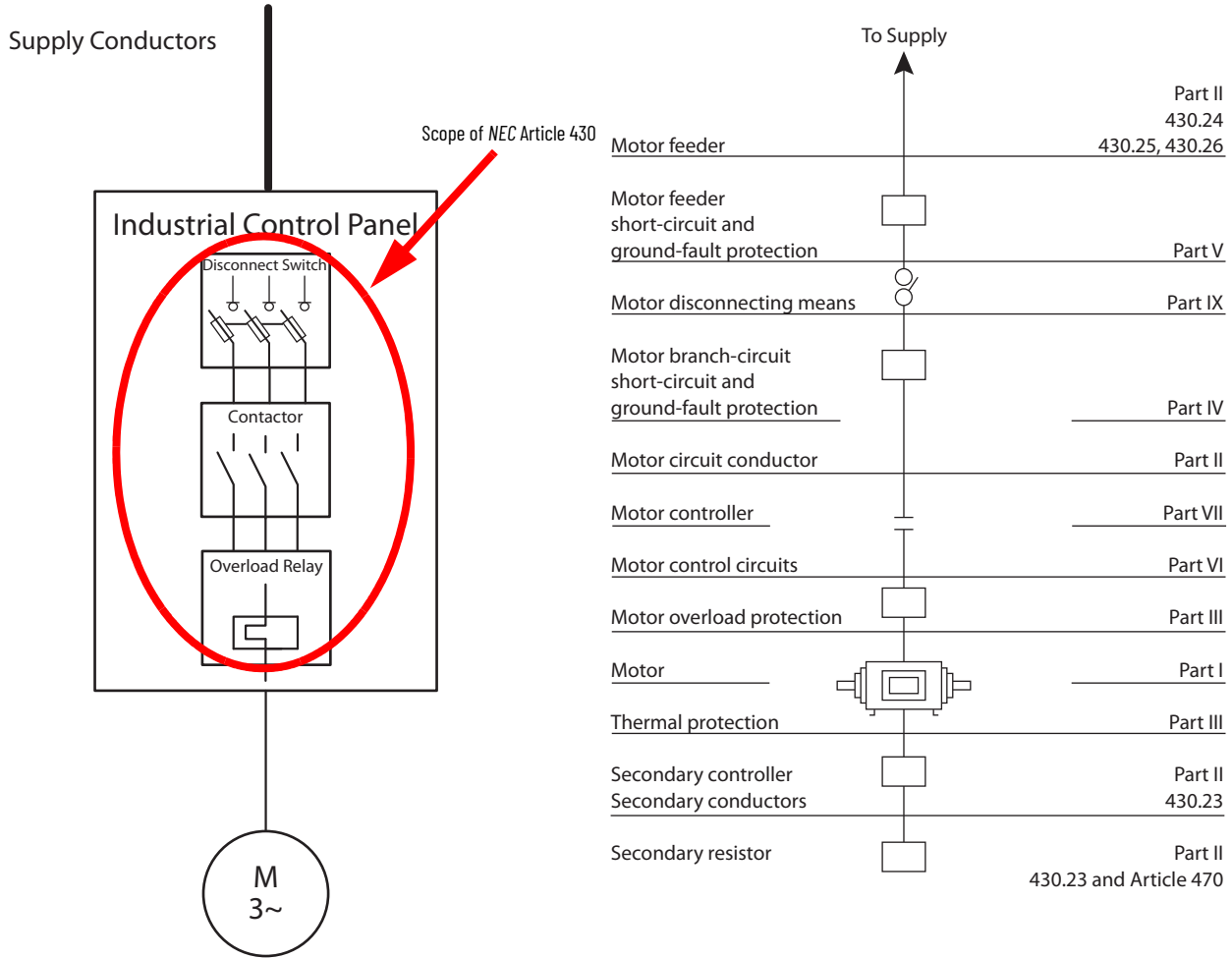

Introduction

In this section, we discuss motors, motor nameplate information, and how the motor determines the rest of the panel design configuration. *NEC* Article 430 provides the most complete information about the requirements of motor control circuits.

This section of Article 430 includes definitions, terminology, and the required marking for motors. Important information can be found on the motor nameplate, including but not limited to full load and locked rotor current, service factor and inverter duty rating. Proper sizing of overload protection in Part III requires the rating or setting of the overload according to full load current and service factor that is located on the motor nameplate. The design letter on the nameplate indicates the motor's speed vs torque characteristics. This design letter can indicate specific design differences, including the motor's locked rotor current and breakdown torque. We can assume that motors are rated for continuous duty; however, intermittent or interval duty is addressed in the standard.

Selection Process

When designing to *NEC* standards, the first component we look at is the motor. It must have sufficient horsepower, voltage, and so on to safely power the machinery with which it is intended to work. Motor characteristics determine everything in the panel design, from wire size to disconnecting means. *NEC* Article 430 provides an outline of the steps that are required to size the components of a motor circuit, as shown in [Figure 4](#).

Figure 4 - NEC Article 430 Contents

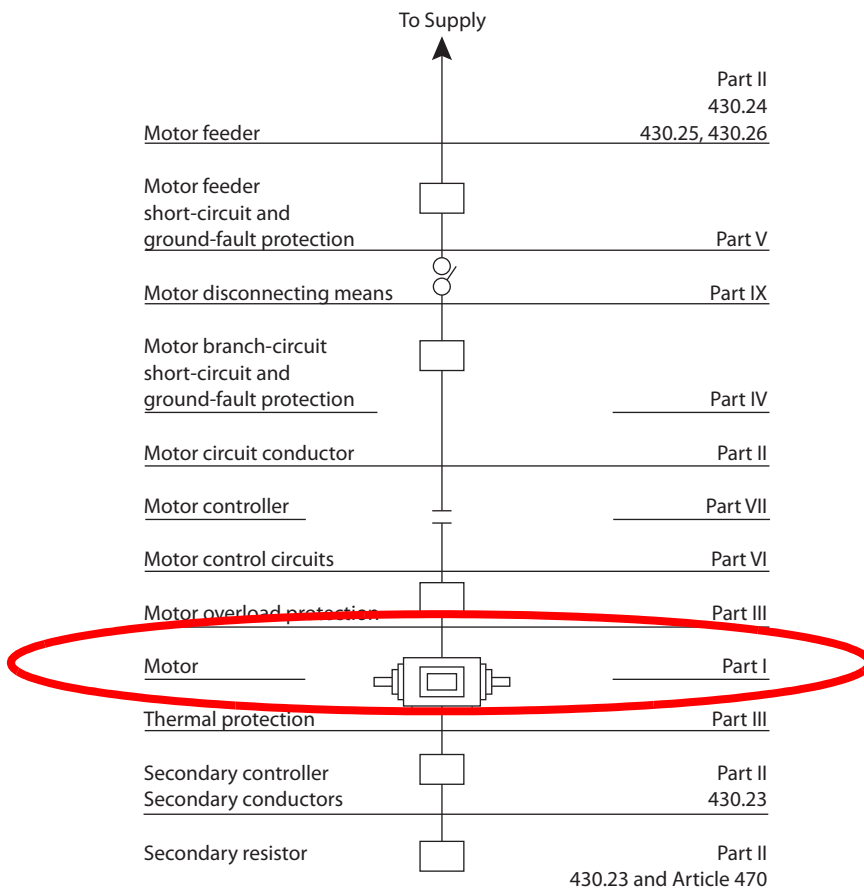

Section 430.6 references table values that must be used in motor full load current (FLC) calculations, rather than the motor nameplate data. The motor nameplate contains useful application information and is a required element on the motor.

Motor Nameplate

The information on a motor nameplate can be arranged in categories. By definition, an induction motor converts electrical energy to useful mechanical energy. The following information provides a brief definition of motor data on the nameplate and some application considerations.

Figure 5 - Typical Motor Nameplate

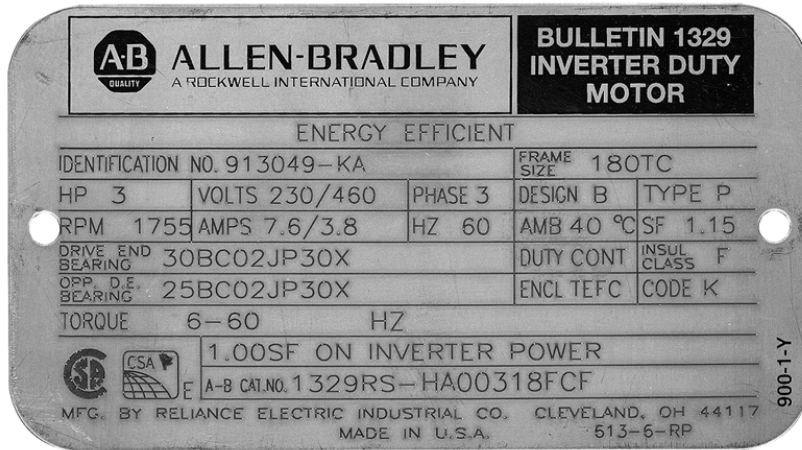

A nameplate contains the data for a typical AC motor; this one is a 3 Hp, 1755 rpm, 180T frame unit.

Electrical input

Voltage. The voltage at which the motor is designed to operate is an important parameter. Standard voltages for motors built to NEMA MG 1 are defined within that standard. One common misapplication is of motors that are marked (rated) at one voltage but applied on a different voltage network using the + 10% voltage tolerance for “successful” operation. Nameplate-defined parameters for the motor such as power factor, efficiency, torque, and current are at rated voltage and frequency. Application at other than nameplate voltage will likely produce different performance.

It is common for manufacturers to mark a wide variety of voltages on one motor nameplate. A common example is a motor wound for 230V and 460V (230/460V) but which is operable on 208V. This 208...230/460V motor has degraded performance at 208V. Another common misconception is to request a motor rated at network voltage; for example, at 480V. The NEMA standard is 460V. The voltage rating assumes that there is voltage drop from the network to the motor terminals. Thus, the 460V motor is appropriate on a 480V network.

Frequency. Input frequency is usually 50 or 60 Hz. When more than one frequency is marked, the nameplate must define other parameters that differ at different input frequencies. The increasing use of adjustable-speed drives (ASDs) is also making it necessary to mark a frequency range, especially for hazardous-duty listed applications.

Phase. This represents the number of AC power lines supplying the motor. Single- and three-phase are typical.

Current. Rated load current (FLC) in amperes (A) is at nameplate horsepower (Hp) with nameplate voltage and frequency. When using current measurement to determine motor load, it is important that correction is made for the operating power factor. Unbalanced phases, under voltage conditions, or both, cause current to deviate from nameplate FLC. Review both motor and drive for a matched system regarding current on ASD applications.

Code. A letter code defines the locked-rotor kVA on a per-Hp basis. Codes are defined in MG 1 by a series of letters from **A** to **V**. Generally, the farther the code letter from **A**, the higher the inrush current per Hp. A replacement motor with a “higher” code may require different upstream electrical equipment, such as motor starters.

Type. NEMA MG 1 requires manufacturer’s type, but there is no industry standard regarding what this is. Some manufacturers use “Type” to define the motor as single or polyphase, single- or multi-speed, or even by type of construction. Type is of little use in defining a motor for replacement purposes unless you also note the specific motor manufacturer.

Power factor. Also given on the nameplate as “P.F.” or “PF,” power factor is the ratio of the active power (W) to the apparent power (VA) expressed as a percentage. It is numerically equal to the cosine of the angle of lag of the input current with respect to its voltage, multiplied by 100. For an induction motor, power factor also varies with load. The nameplate provides the power factor for the motor at full load.

Active power is the power that does work; apparent power has a reactive component. This reactive component is undesirable – the utility company must supply it, but it does no work.

A power factor close to unity (100%) is most desirable. Because there are trade-offs when designing an induction motor for improved efficiency or other performance parameters, power factor sometimes suffers. It can be improved by adding capacitors.

Capacitor correction. The nameplate may list the maximum power-factor correcting capacitor size. Nameplate notation would be similar to “MAX CORR KVAR” followed by a number. The number would indicate capacitor value in kilovars (kVAR). A value greater than the one suggested may result in higher voltages than desired and could damage to the motor or other components.

Design. NEMA MG 1 defines “design”, which defines the torque and current characteristics of the motor. Letters are assigned the defined categories. Most motors are Design B, although the standard also defines Designs A, C, and D. Common headings on nameplates include “Des,” “NEMA Design,” and “Design.”

Figure 6 - Design A, B, C, D for AC Motors

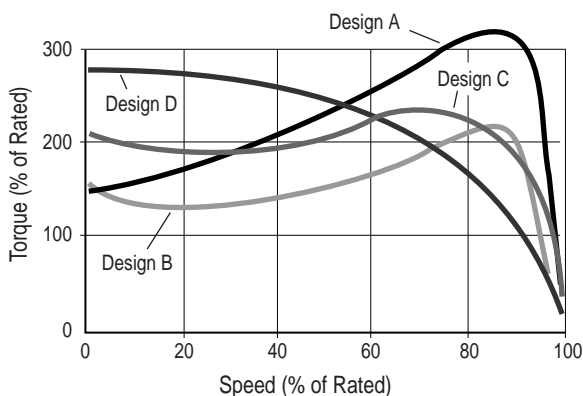

Dimensions

NEMA has standard frame sizes and dimensions designating the height of the shaft, the distance between mounting bolt holes and various other measurements. Integral AC motor NEMA sizes run from 143T-445T, and the center of the shaft height in inches can be figured by taking the first two digits of the frame number and dividing it by 4.

Fractional horsepower motors, for which NEMA spells out dimensions, use 42, 48, and 56 frames. The shaft height in inches can be established by dividing the frame number by 16.

Table 1 - Design A, B, C, D - For AC Motors

NEMA Design	Starting Torque	Starting Current	Breakdown Torque	Full Load Slip	Typical Applications
A	Normal	High	High	Low	Mach. Tools, Fans
B	Normal	Normal	Normal	Normal	Same as Design “A”
C	High	Normal	Low	Normal	Loaded compressor/Loaded conveyor
D	Very High	Low	—	High	Punch Press

Some motors may not conform to any torque-current characteristics defined in NEMA MG 1. The motor manufacturer may assign them a letter that is not a defined industry standard. It is important to check the design letter when replacing a motor in an existing application.

Another note on Design B: Design B constrains the motor designer to limit inrush current to established standards. This insures that the user’s motor-starting devices are suitable. A Design A motor has torque characteristics similar to those of the Design B motor, but there is no

limit on starting inrush current. This may cause starter sizing problems. You should be aware of this and work with the motor manufacturer to insure successful operation of your motor systems.

Performance

NEMA Nom. Efficiency. Efficiency is defined as output power divided by input power expressed as a percentage:

$$(\text{Output/Input}) \times 100$$

NEMA nominal efficiency on a nameplate represents an average efficiency of a large population of like motors.

The actual efficiency of the motor is guaranteed by the manufacturer to be within a tolerance band of this nominal efficiency. The band varies depending on the manufacturer. However, NEMA has established the maximum variation allowed. The maximum that is allowed by NEMA standards represents an additional 20% of motor losses from all sources, such as friction and windage losses, iron losses, and stray load losses. Therefore, you should pay attention to guaranteed minimum efficiencies when evaluating motor performance.

Service factor. The service factor (S.F.) is required on a nameplate only if it is higher than 1.0. Industry standard service factor includes 1.15 for open-type motors and 1.0 for totally enclosed-type motors. However, service factors of 1.25, 1.4, and higher exist.

It is not considered good design practice to use the rating afforded by S.F. continuously; operating characteristics such as efficiency, power factor, and temperature rise are affected adversely.

Duty. This block on the nameplate defines the length of time during which the motor can carry its nameplate rating safely. Most often, this is continuous ("Cont"). Some applications have only intermittent use and do not need motor full load continuously. Examples are crane, hoist, and valve actuator applications. The duty on such motors is usually expressed in minutes.

Figure 7 - Nameplate special markings

ID P56H9000		FR 56		S.F. 1.0		PH. 1	
HP	RPM	% SPEED		LOAD TYPE			
.01	180	10		VARIABLE TORQUE			
.25	450	25		CONSTANT TORQUE			
1	1800	100		CONSTANT TORQUE			
1	2700	150		CONSTANT HORSEPOWER			
TIME RATING	CONT	INS CL	INS TYPE	F	AMB C	40	THERMALLY PROTECTED
INPUT VOLTS	115 VAC		50/60 HZ				
INPUT AMPS	13.1 FULL LOAD						
ENERGY SAVING DESIGN							
WARNING							
THIS MOTOR IS EQUIPPED WITH A THERMOSTAT TO PREVENT INJURY RESULTING FROM UNEXPECTED RESTART. DISCONNECT FROM POWER SOURCE BEFORE REMOVING ANY PROTECTIVE COVERS FROM OR PERFORMING ANY MAINTENANCE ON THIS MOTOR OR DRIVEN EQUIPMENT. HIGH VOLTAGE AND ROTATING PARTS CAN CAUSE SERIOUS OR FATAL INJURY. INSTALLATION, OPERATION AND MAINTENANCE OF ELECTRICAL MACHINERY SHOULD BE PERFORMED BY QUALIFIED PERSONNEL. MAKE SURE THAT THE MOTOR AND EQUIPMENT ARE GROUNDED AND PROTECTED IN ACCORDANCE WITH THE LOCAL AND NATIONAL ELECTRIC CODES, SEE NEMA MG-2 SAFETY STANDARD.							
RELIANCE ELECTRIC INDUSTRIAL COMPANY 602095-71-A CLEVELAND, OHIO 44117				 PLANT M E54825 MADE IN U.S.A.			

You can't tell just from a motor's nameplate whether it is suitable for explosion-proof or dust ignition-proof service. It takes a separate but nearby tag that says it is UL Listed for hazardous locations and goes into more specific detail. The motor that this tag represents is capable of adjustable-speed service

Other special markings may be displayed, such as those of agencies wishing to establish an efficiency certification. You should understand whether any special third-party certifications are required and where you can find the proof.

A growing area of nameplate marking relates to capabilities of a motor when used on an adjustable speed drive. Many standard motors are applied to ASDs using general rules of thumb, without the motor manufacturer even knowing about the application. However, given the proper information about the ASD and application, a motor manufacturer can design a motor, or properly apply an existing design, and stamp the approved parameters on the nameplate. This stamping is always required on UL Listed explosion-proof motors.

Reliability

Insulation class. Often abbreviated “INSUL CLASS” on nameplates, it is an industry standard classification of the thermal tolerance of the motor winding. Insulation class is a letter designation such as “A,” “B,” or “F,” depending on the winding’s ability to survive a given operating temperature for a given life. Insulations of a letter deeper into the alphabet perform better. For example, class F insulation has a longer nominal life at a given operating temperature than class A, or for a given life it can survive higher temperatures.

Operating temperature is a result of ambient conditions plus the energy that is lost in the form of heat (causing the temperature rise) as the motor converts electrical to mechanical energy.

Maximum ambient temperature. The nameplate lists the maximum ambient temperature at which the motor can operate and still be within the tolerance of the insulation class at the maximum temperature rise. It is often called “AMB” on the nameplate and is usually given in °C.

Altitude. This indicates the maximum height above sea level at which the motor remains within its design temperature rise, meeting all other nameplate data. If the motor operates below this altitude, it runs cooler. At higher altitudes, the motor tends to run hotter because the thinner air cannot remove the heat so effectively, and the motor may have to be derated. Not every nameplate has an altitude rating.

Construction

Enclosure. This designation, often shown as “ENCL” on a nameplate, classifies the motor as to its degree of protection from its environment, and its method of cooling. In MG 1, NEMA describes many variations. The most common are Open Drip-Proof (ODP) and Totally Enclosed Fan Cooled (TEFC).

ODP. An open drip-proof (ODP) motor allows a free exchange of air from outside the motor to circulate around the winding while being unaffected by drops of liquid or particles that strike or enter the enclosure at any angle from 0...15° downward from the vertical.

TEFC. A totally enclosed fan-cooled (TEFC) motor helps prevent free exchange of air between inside and outside the motor enclosure. It has a fan that blows air over the outside of the enclosure to aid in cooling.

A TEFC motor is not considered air or water-tight; it allows outside air that contains moisture and other contaminants to enter, but usually not enough to interfere with normal operation. If contamination is a problem in a given application, most manufacturers can provide additional protection such as mill and chemical duty features, special insulations and internal coating, or space heaters for motors subject to extended shutdown periods and wide temperature swings that could make the motor “breathe” contaminants.

Bearings. Though NEMA does not require it, many manufacturers supply nameplate data on bearings, because they are the only true maintenance components in an AC motor. Such information is usually given for both the drive-end bearing and the bearing opposite the drive end.

Nameplate designations vary from one manufacturer to another. For rolling-element bearings, the most common is the “AFBMA Number.” That is the number that identifies the bearing by standards of the Anti-Friction Bearing Manufacturers Association. It provides much information about the bearings and lets you buy bearings from a local distributor.

Some manufacturers use a simplified designation simply indicating the bearing size and type -for example, 6309 for a size 309 ball bearing. This brief information can leave questions like: Is the bearing sealed, shielded, or open? Still, some manufacturers may use special bearings and elect to display their own bearing part numbers on the nameplate. Many special bearings are applied in motors for reasons such as high speed, high temperature, high thrust, or low noise. It pays to understand your motors’ bearing requirements.

Once the motor information has been determined, the next step is to select the appropriate motor circuit conductor. The conductor must be able to carry the motor current without overheating.

NEC provides minimum sizing requirements for conductors, including those used in a motor circuit. Minimum sizing requirements help protect against the sizing of conductors beyond their ampacity and protect against overheating of conductors and even the prevention of fire. The amount of current that a conductor can carry continuously under specific conditions is defined as ampacity. The number of conductors that are grouped together can affect ampacity values. Temperature must also be factored into a conductor's load-carrying capabilities. Correction tables are provided to address ambient temperature.

Figure 8 - NEC Article 430 Contents

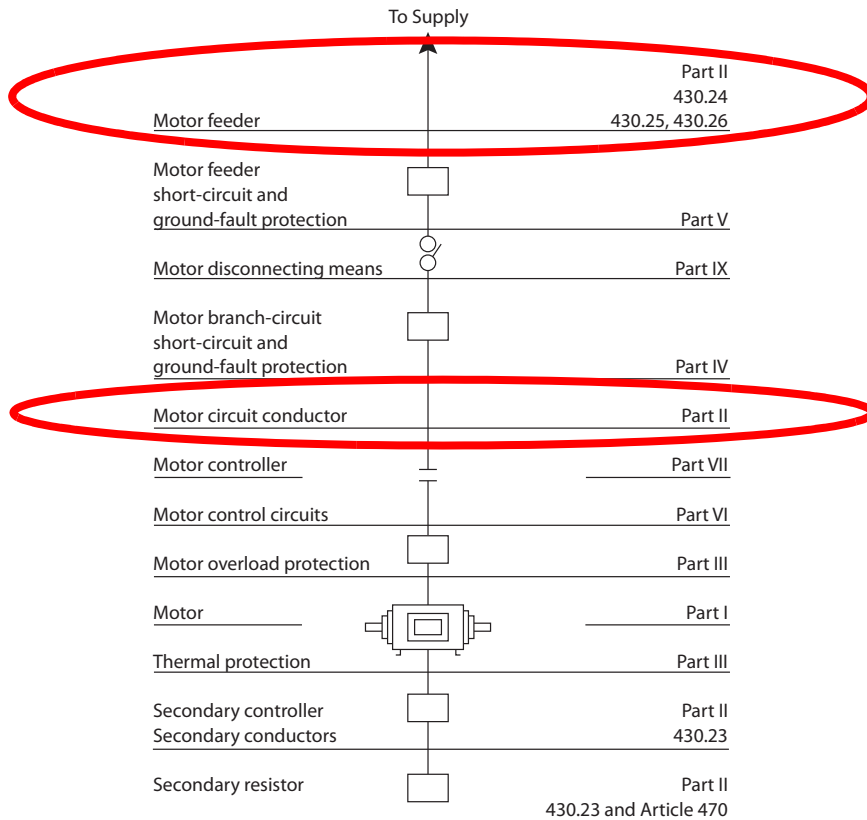

Wire Size

American wire sizes differ from those used by many other regions. In the United States, wire is measured using the American Wire Gauge (AWG) system, which measures the diameter of the conductor (the bare wire) with the insulation removed.

In Europe, wire sizes are expressed in cross-sectional area in mm² and also as the number of strands of wires of a diameter expressed in mm. For example, 7/0.2 means 7 strands of wire each 0.2 mm diameter. This example has a cross sectional area of 0.22 mm². [Table 2](#) compares AWG and metric wire sizes.

Table 2 - Wire Size Comparison

AWG Number	Wire Diameter			AWG Number	Wire Diameter		
	in	mm	mm ²		in	mm	mm ²
6/0 = 000000	0.580	14.73	170.30	18	0.0403	1.02	0.823
5/0 = 00000	0.517	13.12	135.10	19	0.0359	0.912	0.653
4/0 = 0000	0.460	11.7	107	20	0.0320	0.812	0.518
3/0 = 000	0.410	10.4	85.0	21	0.0285	0.723	0.410
2/0 = 00	0.365	9.26	67.4	22	0.0253	0.644	0.326
1/0 = 0	0.325	8.25	53.5	23	0.0226	0.573	0.258
1	0.289	7.35	42.4	24	0.0201	0.511	0.205
2	0.258	6.54	33.6	25	0.0179	0.455	0.162
3	0.229	5.83	26.7	26	0.0159	0.405	0.129
4	0.204	5.19	21.1	27	0.0142	0.361	0.102
5	0.182	4.62	16.8	28	0.0126	0.321	0.0810
6	0.162	4.11	13.3	29	0.0113	0.286	0.0642
7	0.144	3.66	10.5	30	0.0100	0.255	0.0509
8	0.128	3.26	8.36	31	0.00893	0.227	0.0404
9	0.114	2.91	6.63	32	0.00795	0.202	0.0320
10	0.102	2.59	5.26	33	0.00708	0.180	0.0254
11	0.0907	2.30	4.17	34	0.00631	0.160	0.0201
12	0.0808	2.05	3.31	35	0.00562	0.143	0.0160
13	0.0720	1.83	2.62	36	0.00500	0.127	0.0127
14	0.0641	1.63	2.08	37	0.00445	0.113	0.0100
15	0.0571	1.45	1.65	38	0.00397	0.101	0.00797
16	0.0508	1.29	1.31	39	0.00353	0.0897	0.00632
17	0.0453	1.15	1.04	40	0.00314	0.0799	0.00501

Single Motor Conductor Sizing

In general, Section 430.22 specifies that the conductors used to supply a single motor in continuous duty must be sized at a minimum of 125% motor FLC. Continuous duty is defined as a motor that is in operation for longer than 3 hours.

The provision for a conductor with an ampacity of at least 125% of the motor full-load current rating is not a conductor derating; rather, it is based on the need to provide for a sustained running current that is greater than the rated full-load current and for protection of the conductors by the motor overload protective device set above the motor full-load current rating.

The conductor requirements apply to motor circuits 1000V or less, and for continuous duty. The ampacity of branch circuit conductors is calculated from motor FLC in Tables 430.248...430.250, rather than the motor nameplate.

Figure 9 - Single motor conductor sizing

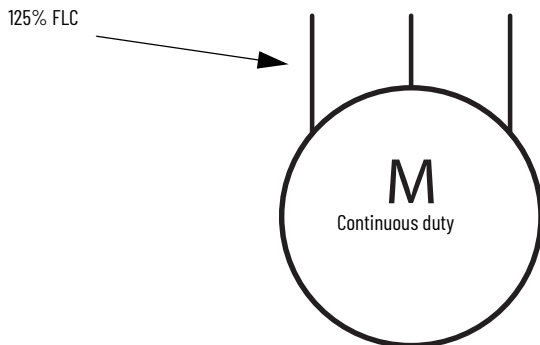

Determining Conductor Size

1. Determine the horsepower of the motor.
2. Locate the appropriate table, and determine the motor FLC.
3. Multiply the motor FLC by 1.25. This value is the ampacity that is required of motor conductors.
4. Use appropriate tables and correction factors from Section 310.15(B) to determine the correct wire gauge.

Wye-Delta Configurations

The conductor sizing requirements are basically the same as for standard branch circuits. The conductor must be sized for 125% motor FLC. The main difference in this application is that the Wye-Delta motor runs at 58% of the standard motor FLC. This is addressed in *NEC* Section 430.22.

Figure 10 - Conductor sizing for Wye-Delta motors

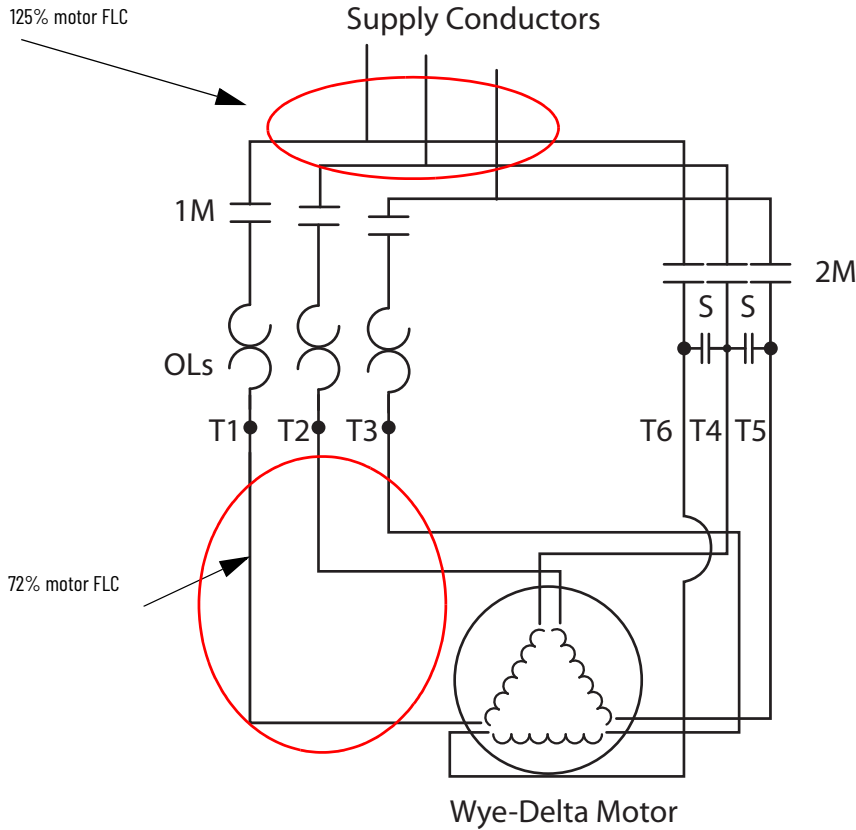

Considering the application information, the conductor sizing calculation is as follows:

- $58 \times 1.25 = 72\%$ motor FLC
- Use appropriate tables and correction factors from Section 310.15(B) to determine the correct wire gauge.

Multi-speed Motors

In applications where motors are designed to operate at different speeds (example: low and high), conductors need to be sized to the highest FLC marked on the motor. Conductors between the controller and the motor should be sized to the nameplate ratings of the windings, per Section 430.22(B).

Figure 11 - Conductor sizing for multi-speed motors

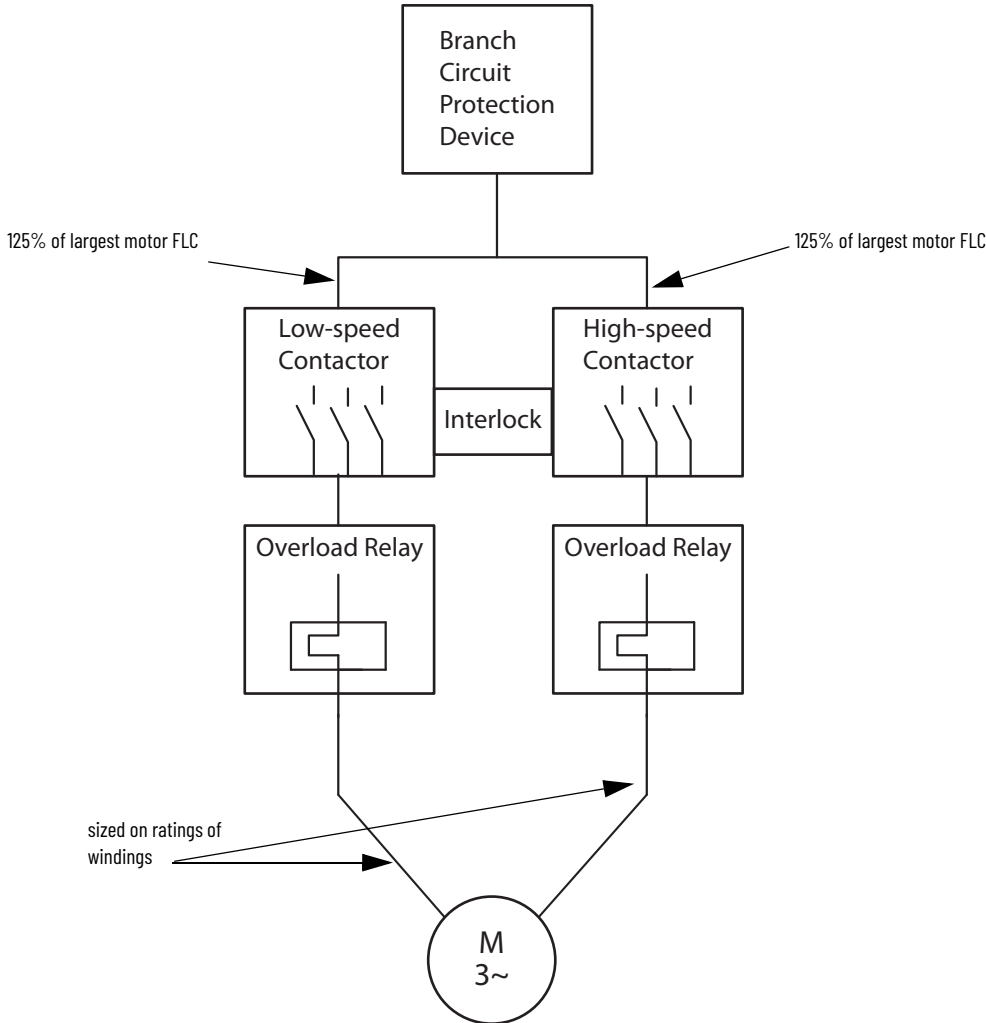

To determine the conductor sizing for multi-speed motors:

1. Determine the highest FLC motor from the motor nameplate
2. Multiply that value by 1.25. This is the ampacity value that you will use to select the conductor.
3. Use appropriate tables and correction factors from Section 310.15(B) to determine the correct wire gauge.

Feeder Conductor Sizing

Section 430.24 states that motor feeder conductors supplying multiple loads shall have a rating not less than the sum of the highest breaker rating of any of its branches and the full-load currents of all other motors that are served by the feeder.

Figure 12 - Feeder conductor sizing

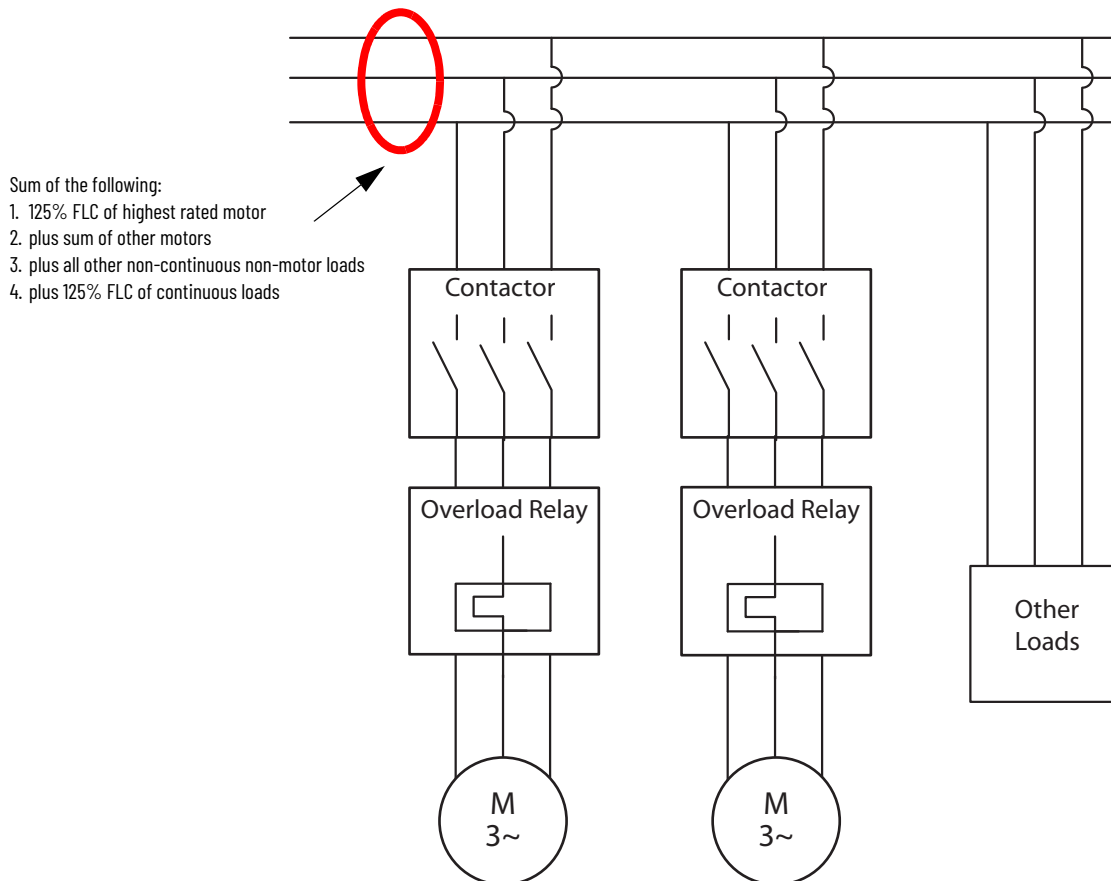

To determine the feeder conductor sizing:

1. Determine FLC of highest speed motor
2. Multiply that value by 1.25.
3. Add the sum of the FLC of all other motor loads
4. Add the sum of all other non-continuous non-motor loads
5. Add in 125% FLC of all continuous non-motor loads
6. Use appropriate tables and correction factors from Section 310.15(B) to determine the correct wire gauge, based on the sum of [step 1...step 5](#).

Introduction

Part III of Article 430 is the requirement for overload protection for motors, conductors, and control devices in a motor circuit. Overloads provide a degree of protection from excessive heating during the starting or running of a motor. Abnormal operating conditions for extended amounts of time can lead to damage or even fire. These conditions can be a result of excessive mechanical loads, a single phase condition, motor stalling, or locked rotor conditions. Overload protection must respond to any of these conditions before the motor could overheat or be damaged. In addition, the *NEC* clarifies that overload relays are not capable of opening short circuits or ground faults, so they must be used in conjunction with a branch circuit protection device.

Figure 13 - NEC Article 430 Contents

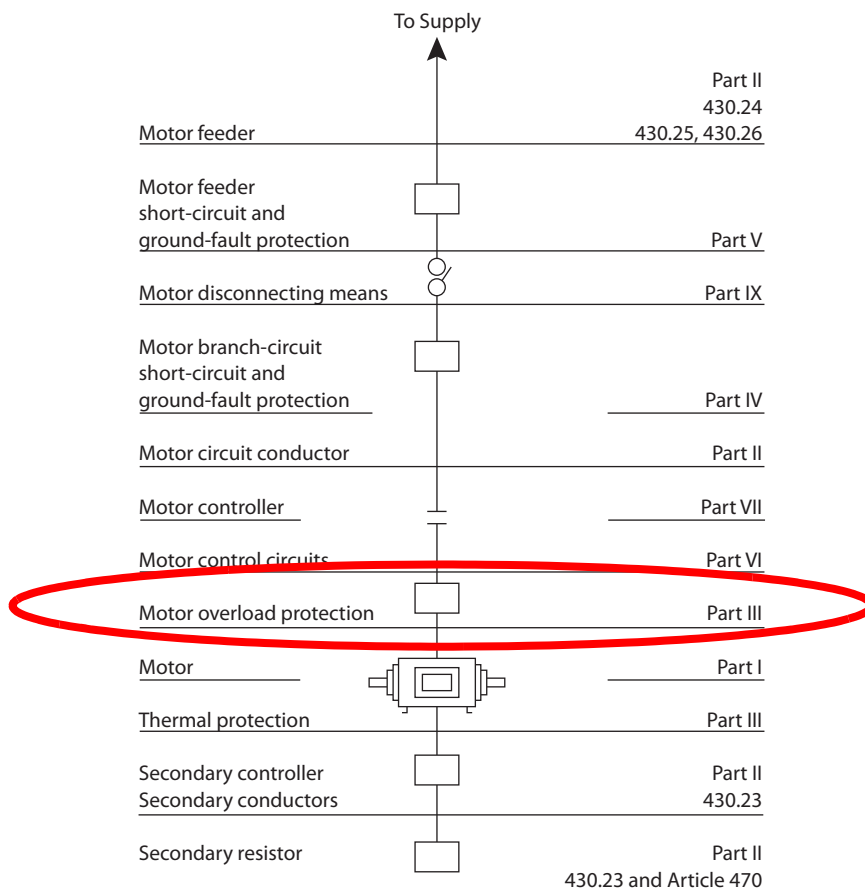

Types of Overload Protection

NEC Section 430.32 permits several types of overload protection, depending on the application. These include the following:

- Thermal protector integral to the motor
- Separate overload device
- Overload device located in the motor controller

Basic Sizing Requirements

The basic requirements for overload device sizing are laid out in *NEC* Section 430.31. they do not apply to motor circuits rated over 1000V nominal, or in situations where power loss would cause a hazard.

In general, overload protection is required for motors over 1 Hp that run continuously (defined as > 3 hours). If there is a different duty cycle, you must use the multipliers that are outlined in Table 430.22 (E). Selection and sizing of elements is affected by motor FLC, service factor, and operating temperature. Overloads must be sized or set so that they allow the motor to start and carry the load.

Typical overload devices are designed to be set at motor FLC. It is important to read the manufacturer’s instructions for the device, as default trip settings may differ.

NEC Section 430.32 has the following max. ratings:

- 125% motor nameplate FLC for motors where the service factor is ≥ 1.15
- 125% motor nameplate FLC for motors where the temperature rise is $\leq 40\text{ }^\circ\text{C}$
- 115% motor nameplate FLC for all other motors

The above values are the maximum values allowed.

Figure 14 - Basic overload sizing (Max ratings)

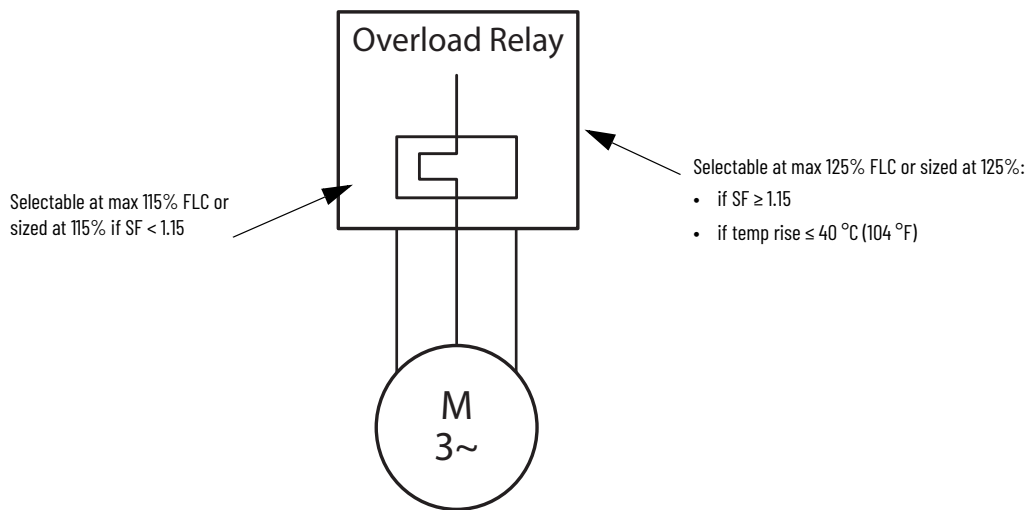

Short-Circuit and Ground Fault Protection of Motor Branch Circuits

Introduction

In this section, we discuss Part IV of *NEC* Article 430, which addresses short-circuit and ground fault protection of a motor branch circuit.

Part IV sets the minimum requirements for protection of conductors, motor control apparatus, and motors from overcurrent conditions due to short circuits and ground faults. The use of self-protected combination motor controllers and other types of motor branch circuit protection are described under individual motor circuits. The requirements (rating or setting) of the branch circuit protection device for both individual motor circuits and multi-motor circuits are contained in this section. Table 430.52 lists the maximum permissible rating or setting of fuses and circuit breakers according to motor types. While this table provides maximum values, the branch circuit protection should be sized as low as possible for maximum protection yet should still be allowed to carry the starting current of the motor.

Part IV also allows for the protection of multiple motors or a motor and other load types using a single short circuit/ground fault protection device. This practice is also known as a group motor installation.

Figure 15 - NEC Article 430 Contents

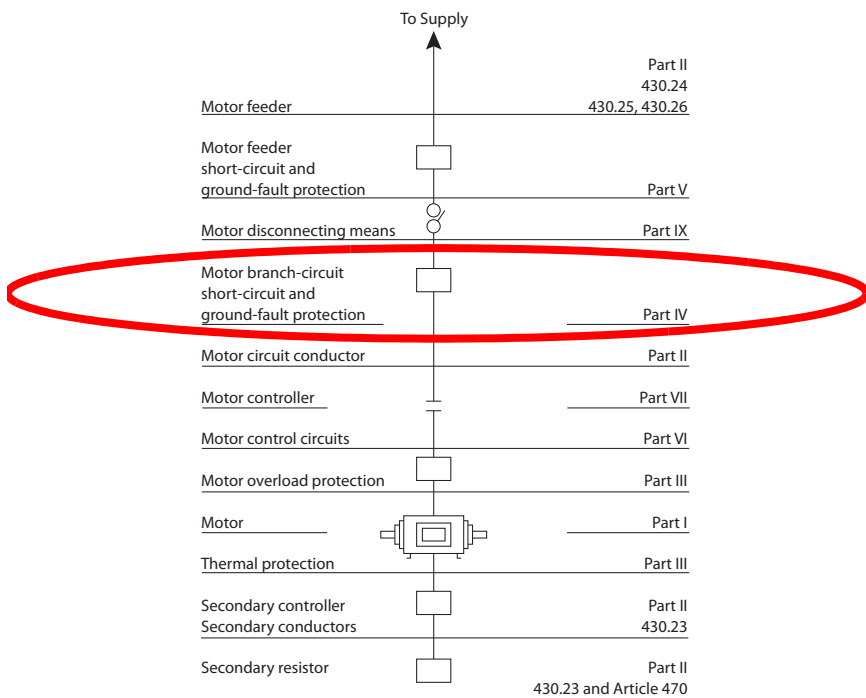

UL 508A and *NEC* both use a set of standard sizes for both fuses and fixed trip circuit breakers, which are shown in [Table 3](#).

Table 3 - Standard Ampere Ratings for Fuses and Fixed-trip circuit breakers

Standard Ampere Ratings [A]					
15	50	110	250	600	2000
20	60	125	300	700	2500
25	70	150	350	800	3000
30	80	175	400	1000	4000
35	90	200	450	1200	5000
40	100	225	500	1600	6000
45			—		
Additional standard ratings for fuses [A]					
1	3	6	10	601	

Single Motor Applications

NEC Section 430.52 sets the minimum requirements for protection of conductors, motor control apparatus, and motors from overcurrent conditions due to short circuits and ground faults. The use of a self-protected combination motor controller and other type of motor branch circuit protection are described under individual motor circuits. The requirements (rating or setting) of the branch circuit protection device for both individual motor circuits and multi-motor circuits are contained in this section. Table 430.52 lists the maximum permissible rating or setting of fuses and circuit breakers according to motor types. While this table provides maximum values, the branch circuit protection should be sized for optimal protection yet still allow for the starting current of the motor.

Motors using Circuit Breakers

Figure 16 illustrates one example of sizing an inverse time circuit breaker that is used for motor branch short-circuit and ground fault protection.

Figure 16 - Standard short-circuit protection

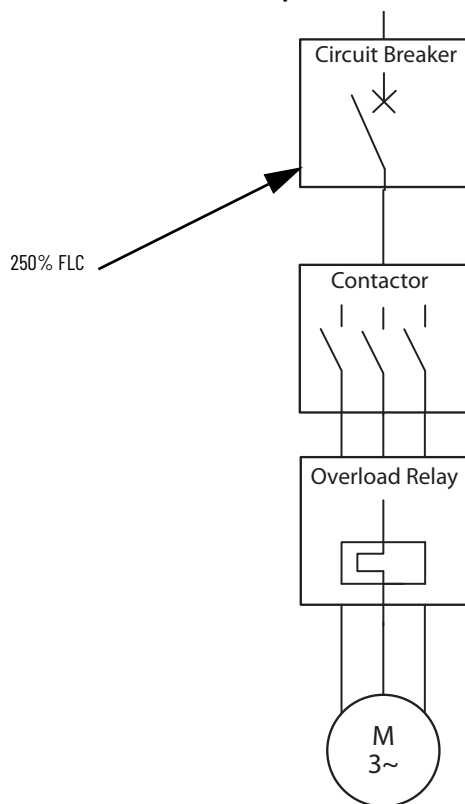

To size an inverse time circuit breaker correctly, complete the following:

1. Using Tables 430.247...430.250, determine the motor FLC
2. From Table 430.52, find the correct max setting value for standard short-circuit protection
3. Multiply the motor FLC by the value in Table 430.52
4. Round up to the nearest standard rating

NEC Section 430.52(c)(1) addresses some exceptions to the standard method. When there are applications where the rating determined is not sufficient for the starting FLC of the motor. This exception allows the inverse time circuit breaker to be sized up to 400% FLC for loads less than 100 A.

Figure 17 - Exception to short-circuit protection sizing

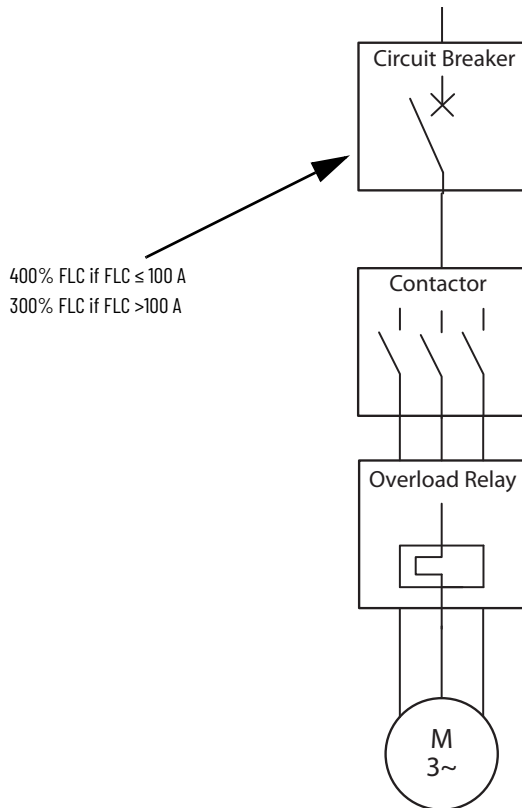

To size an inverse time circuit breaker correctly with this method, complete the following:

1. Using Tables 430.247...430.250, determine the motor FLC
2. From Section 430.52(c)(1), find the correct max. setting value for max. short-circuit protection
3. Multiply the motor FLC by the value from Section 430.52(c)(1)
4. Round down to the nearest standard rating

Fuses

Protective devices are generally rated according to Table 430.52. Fuses are sized according to the same general principles as circuit breakers, with the addition of some smaller standard sizes.

Multi-Motor Applications

Several motors or motor loads on the same branch circuit

Part IV also allows for the protection of multiple motors or a motor and other load types using a single short circuit/ground fault protection device. This type of construction leads to space savings and cost reduction as an alternative to installing a circuit protection device ahead of each motor. Restrictions on the conductor sizing and length must be followed and are detailed in both National and Canadian Electrical codes as well as the UL508A standard. The *NEC* clarifies that the branch circuit protection used must be either an inverse time circuit breaker or branch circuit fuse.

Motors and motors with other load with a single branch circuit protection device fall under 3 categories:

- Installations where all motors are less than 1 Hp in size
- Installations where the smallest motor is protected in the group is according as allowed in a single motor installation (see Table 430.52)
- All other installations fall within "other group installations"

This practice commonly referred to as "group motor installation" often requires the use of motor controllers or motor overloads to be listed as "listed for group installations". Specific rules for the sizing of conductors to the motor must be followed. These may be better known as tap conductor rules.

Figure 18 - Multiple motors on the same branch circuit (≤ 1 Hp each)

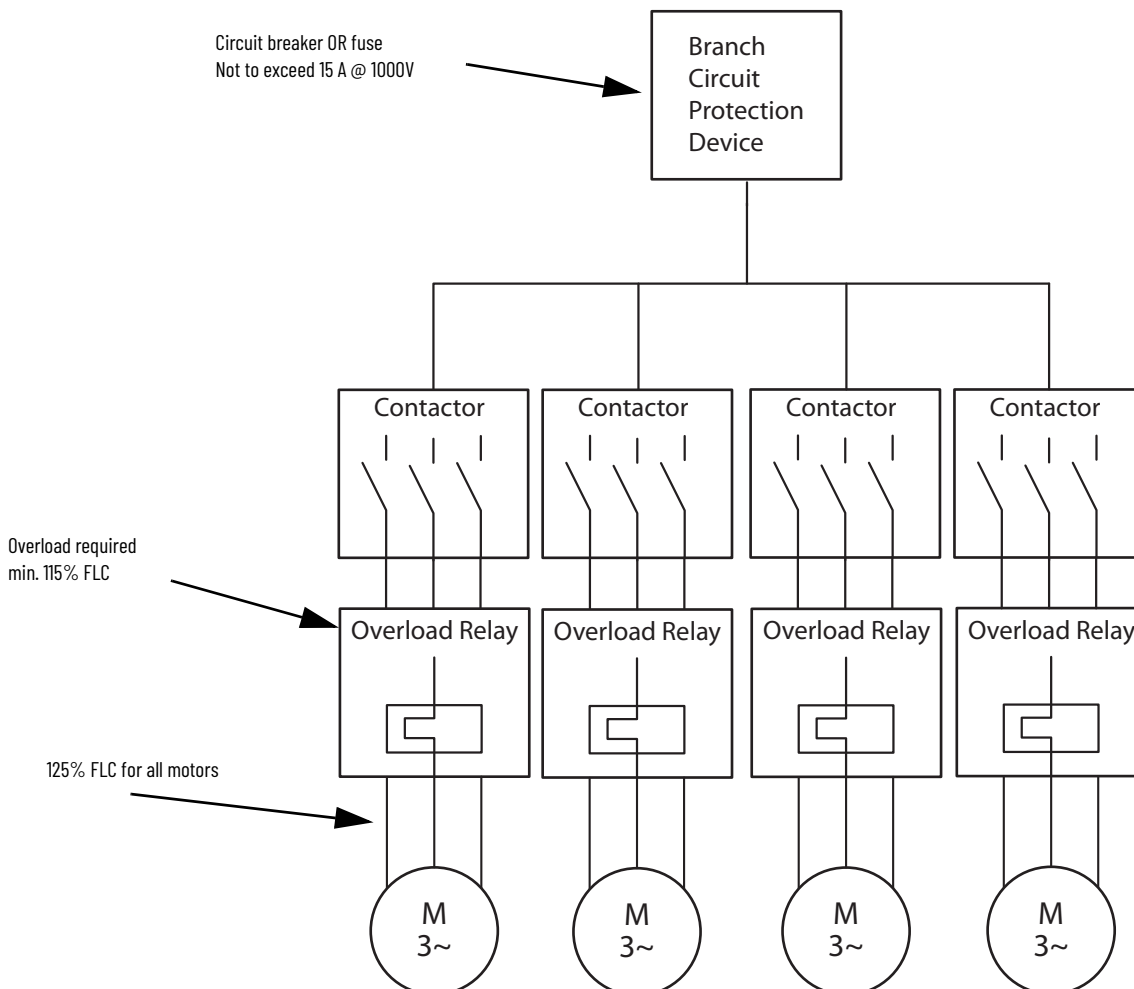

In the application shown in [Figure 18](#), the configuration is allowed because all motors are ≤ 1 Hp and the Branch Circuit Protection Device is a fuse or circuit breaker. Type E Self-Protected devices are not permissible. FLC of each motor must be < 6 A, and all other individual branch circuit requirements (such as overload) must be met.

Figure 19 - Multiple motors on a single controller

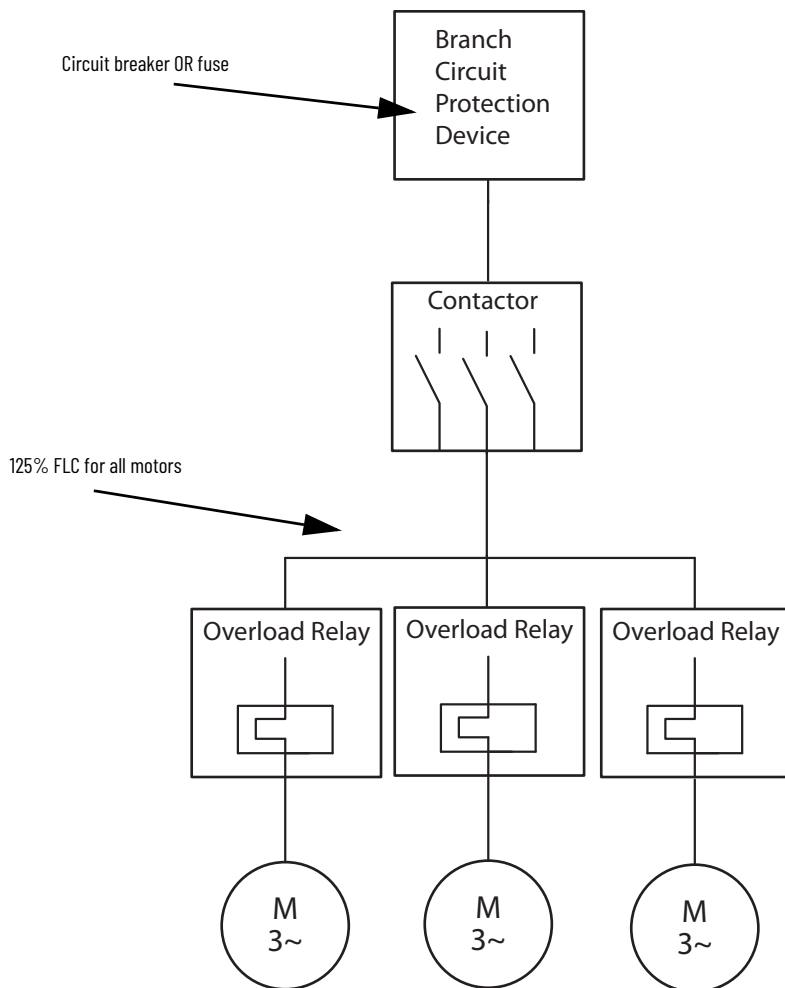

Introduction

In this section, we discuss Part V of *NEC* Article 430, which addresses short-circuit and ground fault protection of a motor feeder circuit. A typical industrial control panel is a feeder circuit as defined by the *NEC*, where a feeder is composed of the wires between the service entrance of the panel or line side of the circuit breaker or disconnect switch and the line side of the final branch circuit protective device.

In many industrial control applications, motor control is involved. In that case, you must then follow *NEC* Article 430, which states that breakers for feeders having mixed loads, for example, heating (lighting and heat appliances) and motors, should have ratings suitable for carrying the heating loads, plus the capacity required by the motor loads. For motor loads, Article 430 states that breakers for motor feeders shall have a rating not greater than the sum of the highest breaker rating of any of its branches and the full-load currents of all other motors that are served by the feeder.

Figure 20 - NEC Article 430 Contents

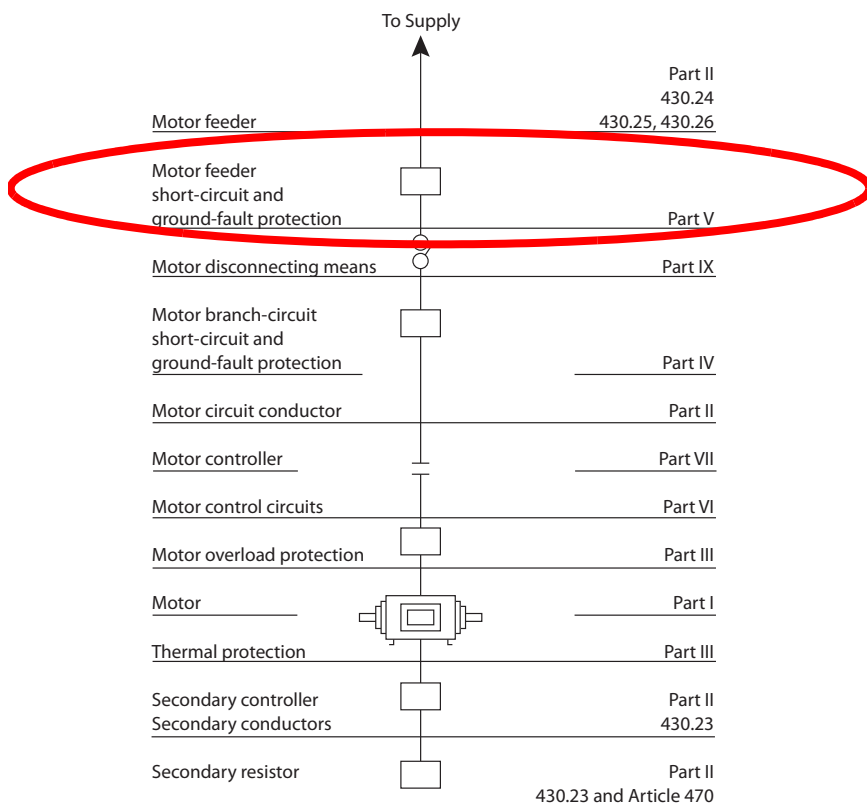

Sizing the Motor Feeder Protective Device (Maximum)

In this method, we are calculating the maximum size of the protective device, based on *NEC* Section 430.62, which requires that the rating of the protective device be no greater than the sum of the largest motor protective device and the sum of all other full-load currents of the other motors of the group. This example assumes a motor voltage of 230V AC.

Figure 21 - Sizing the motor feeder protective device (max.)

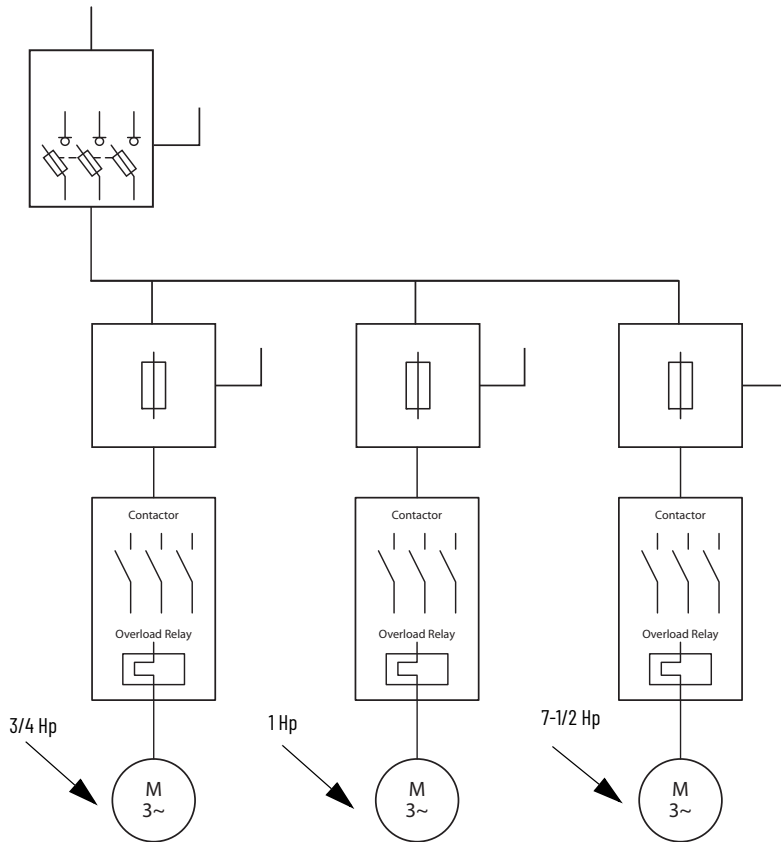

The rating of the motor feeder short-circuit / ground fault protective device is determined by the adding the rating of the largest branch circuit protective device to the full load currents of all of the other motors supplied by that feeder (we assume the Branch Circuit Protection Device in the branch is the same type as in the feeder).

Using Table 430.250, the motor FLC is as follows:

- Motor 1 = 3.2 A
- Motor 2 = 4.2 A
- Motor 3 = 22 A - requires 50 A inverse time circuit breaker; sized for max. allowable under Section 430.52

Adding the values together gives us the following:

- $3.2 + 4.2 + 50 = 57.4$ A

To follow the requirements of Section 430.62, we must round down to the nearest standard size, which is 50 A.

Sizing the Motor Feeder Protective Device (Minimum)

These calculations assume that the circuit breaker or disconnect switch that is selected has a voltage rating equal or greater than the application and that the interrupting rating is equal or greater to the available short circuit current. The panel contains a main feeder breaker supply with three motor branch circuits.

Figure 22 - Sizing the motor feeder protective device (Min)

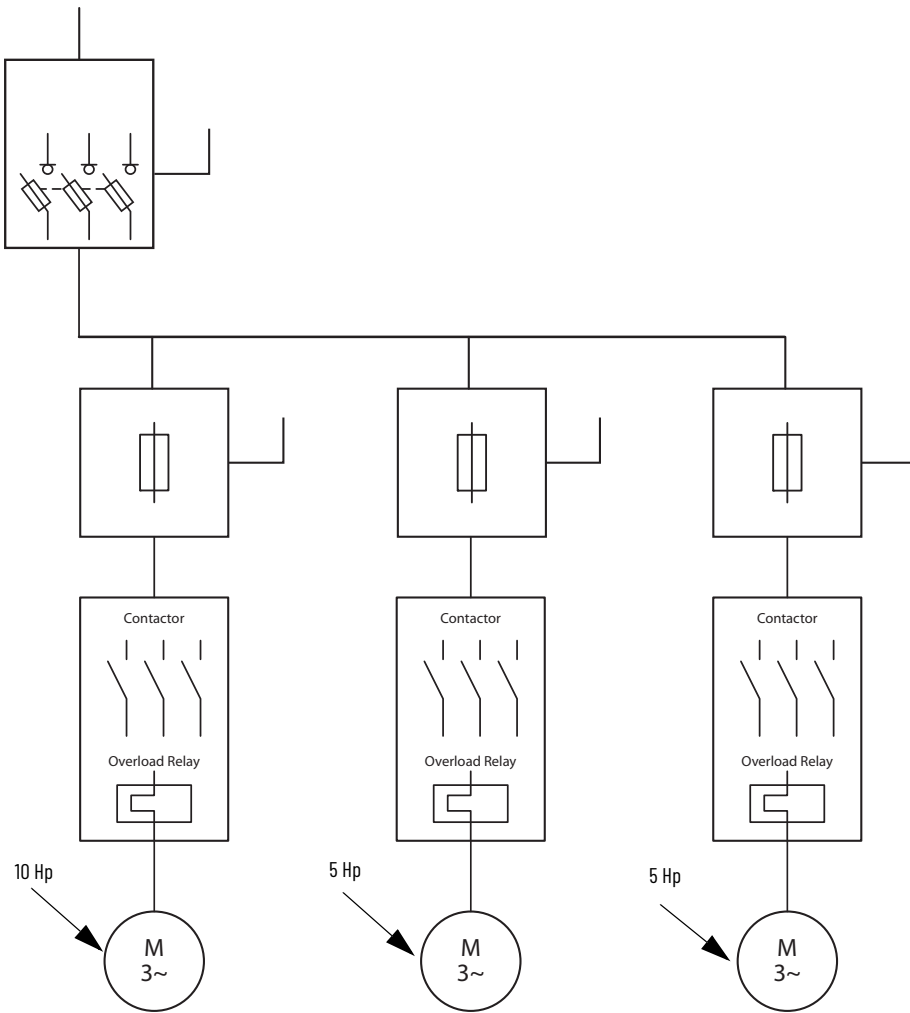

To determine rating of the breaker correctly, we first need to determine the total ampacity of the system.

In our application, the feeder is supplying a 3-motor system at a voltage of 480V. Ampacity is determined from *NEC* Article 430, Table 430.250.

- Motor 1 is 10 Hp. Ampacity is 14 A.
- Motor 2 is 5 Hp. Ampacity is 7.6 A.
- Motor 3 is 5 Hp. Ampacity is 7.6 A.

To calculate the total system FLC, we calculate the sum of the motor loads and multiply that value by 125%. In this scenario, the current calculation is:

- Motor 1 = 14 A
- Motor 2 = 7.6 A
- Motor 3 = 7.6 A
- Total = 29.2 A
- $29.2 \text{ A} \times 125\% = 36.5 \text{ A}$

Because the total load comes to 36.5 A and there is not a commercially available breaker available for 36.5 A, the *NEC* allows the next largest standard-sized breaker to be used. Therefore, you could select a 40 A molded case circuit breaker to protect this control panel.



Each individual motor branch still also requires protection

Introduction

Part VII of *NEC* Article 430, beginning with Section 430.81, is intended to ensure that equipment is provided with controllers that can safely operate the circuit. Motor controllers are devices that are designed to repeatedly establish and interrupt the electrical circuit to a motor. American applications may list the motor controller by NEMA sizes or maximum horsepower and voltage. They are evaluated to the UL60947-4-1 (formerly UL508) standard for industrial equipment.

Some manual motor controllers meet American requirements for a Type “E” motor controller. Type E motor controllers are suitable for use as the branch circuit protection device in a motor circuit where traditionally an inverse time circuit breaker or branch fuse was used. Some motor controllers may meet additional requirements, including disconnecting means at the motor, or as suitable to be used in group motor installations.

Figure 23 - NEC Article 430 Contents

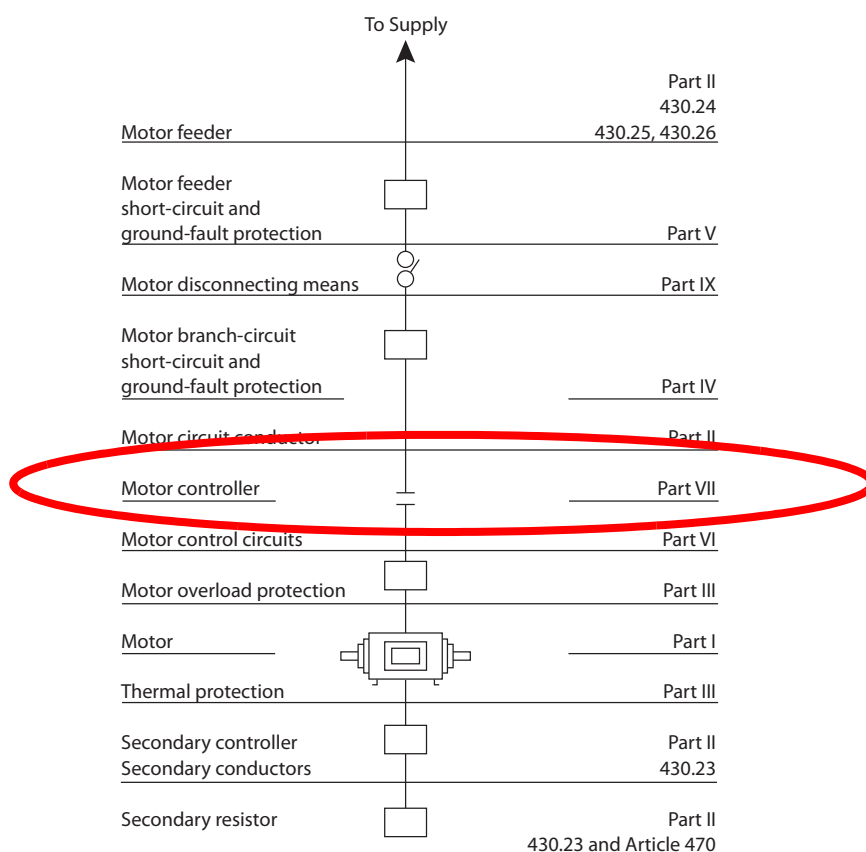

Controller Requirements

Each motor is required to have its own controller, except under certain conditions. This controller can be a contactor/starter, circuit breaker, etc. that performs the following functions:

- Must start, stop, and interrupt motor current
- Have adequate ratings for the application, per Section 430.83(A), unless it falls under an allowable exception
- Generally not required to open all conductors to the motor

Figure 24 - Basic Motor Controller

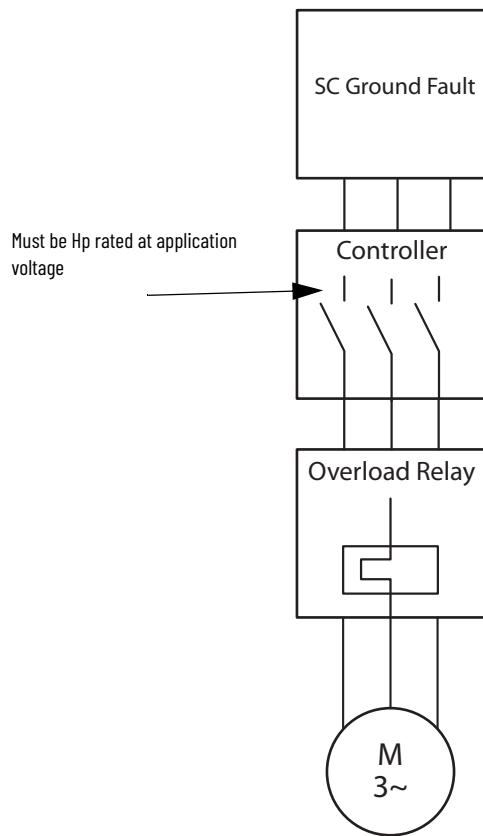

Motor controllers must be horsepower-rated for application voltage, unless an inverse time circuit breaker or molded case switch is used as the controller.

Typical motor controllers include:

- Starters
- Contactors
- Motor protection circuit breakers
- Solid-state relays
- Solid-state motor controllers
- Adjustable-speed drives

Type E motor controllers meet the requirements for branch circuit protection when used in a motor circuit, as shown in [Figure 25](#). When combined with a magnetic contactor, as shown below, the two devices make up a combination motor controller. Combination motor controllers provide:

- Disconnecting means
- Branch circuit protection
- Motor controller
- Motor overload

Figure 25 - Motor Controller as Branch Circuit Protective Device

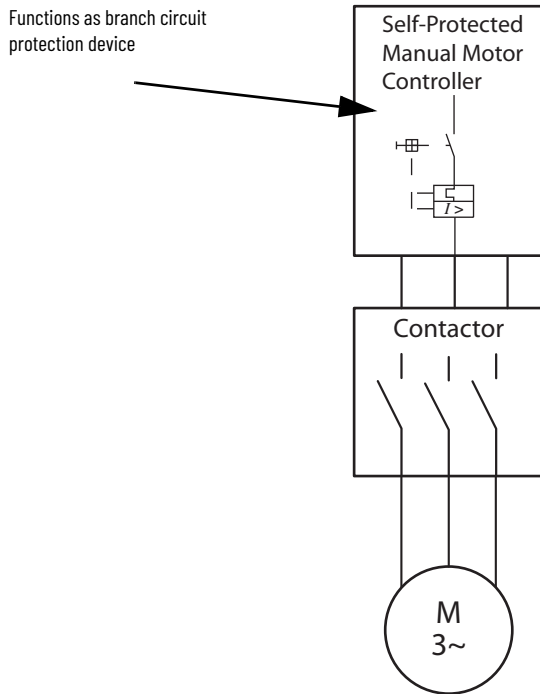

Single Controller with Multiple Motors

Section 430.87 outlines situations in which you can use a single controller for multiple motors. These are:

- If all motors control components of a single piece of machinery, they may be controlled by a single motor controller
- If all motors are $\leq 1/8$ Hp, 1 controller is allowable
- If the overcurrent device is sized to comply with 450.53(A)

Figure 26 - Single controller with multiple motors

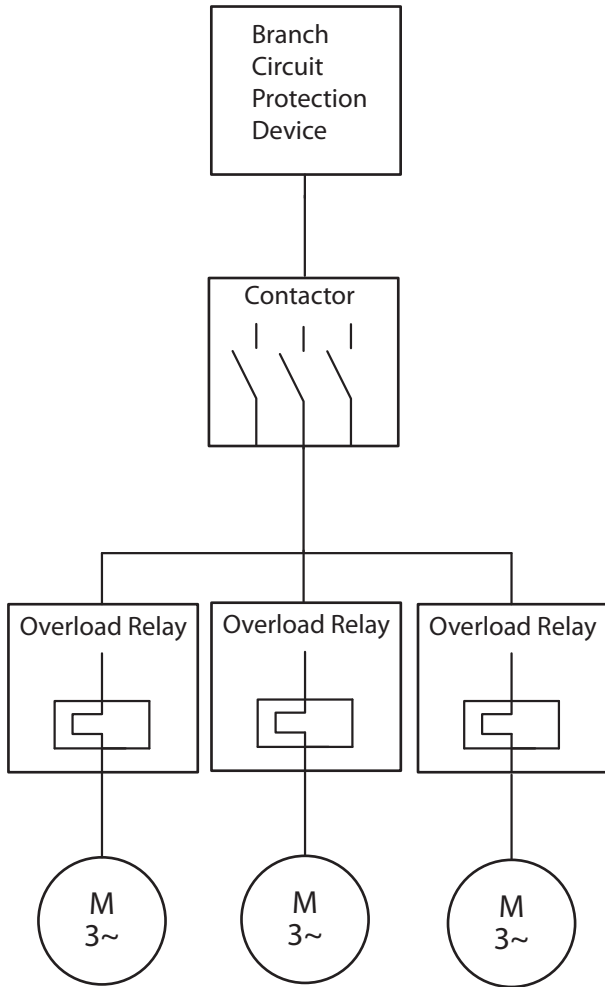

Introduction

In this section, we discuss Part VI of *NEC* Article 430, which addresses the motor control circuit. The control circuit uses control devices to determine when loads are energized or de-energized by controlling current flow. Control circuits usually carry lower voltages than power circuits.

Control circuits are further broken into two subcategories; Class 1 control circuits, up to 600V and Class 2 energy-limited control circuits, up to 30V.

Figure 27 - NEC Article 430 Contents

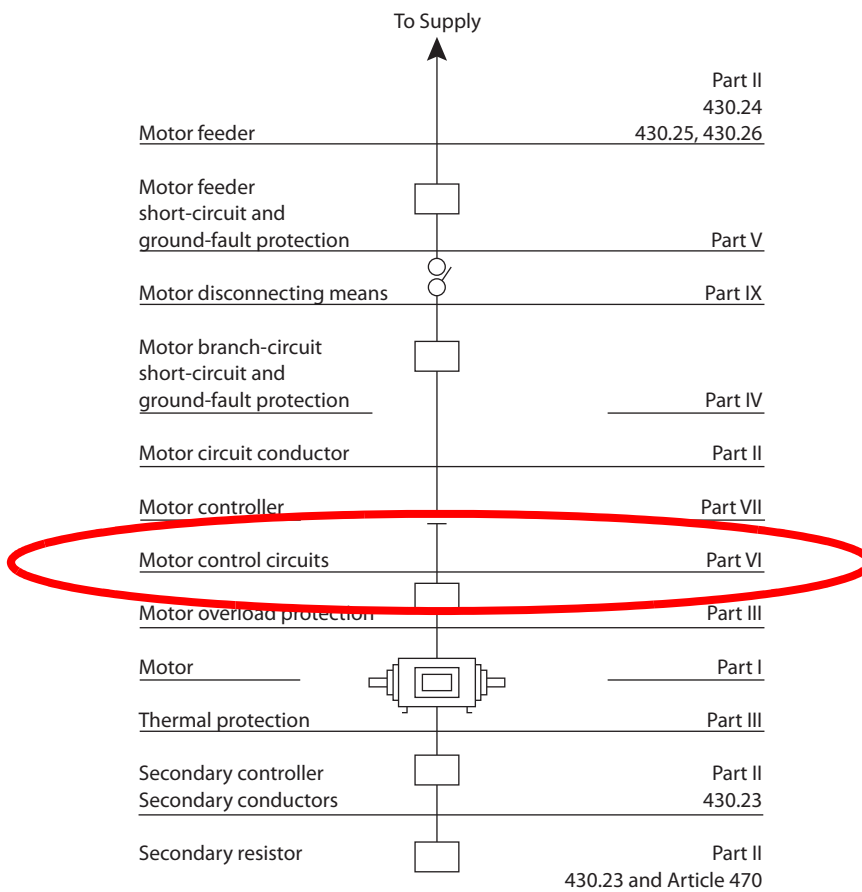

Transformers

Transformer with two primary fuses and one secondary fuse

Figure 28 - Transformer with primary and secondary fusing

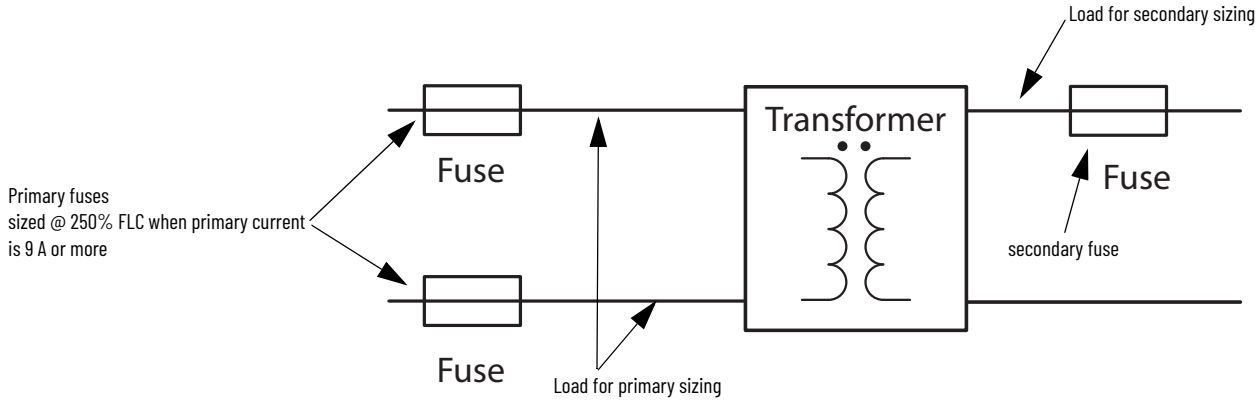

The conductors between the fuse and the transformer on the primary side and between the transformer and the fuse on the secondary side have different sizing requirements, which are outlined in [Table 4](#).

Table 4 - Fuse requirements for primary and secondary windings

Primary Winding		Secondary Winding	
Rated Amperes [A]	Overcurrent [% of rated FLC]	Rated Amperes [A]	Overcurrent [% of rated FLC]
9 or more	250	9 or more	125
2...8.99	250	less than 9	167
less than 2	500	–	–

Transformer with two primary fuses

Figure 29 - Transformer with only primary fusing

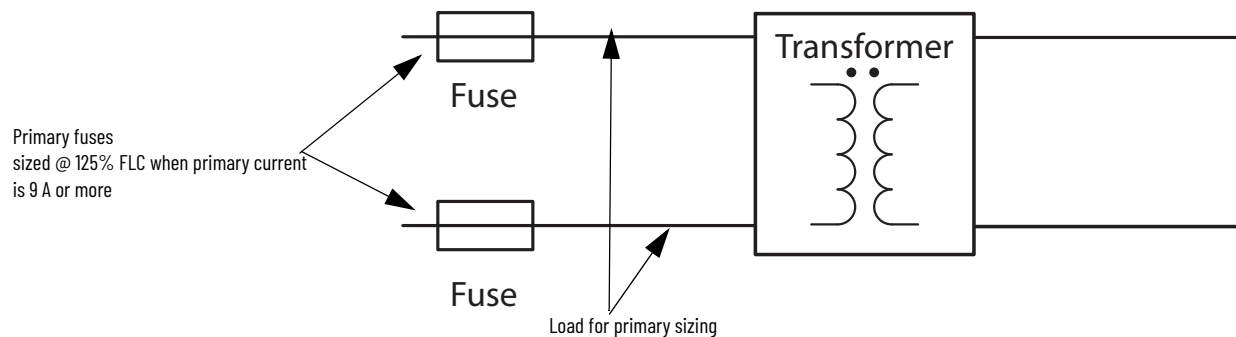

[Table 5](#) lists the conductor sizing requirements for fuses in these applications.

Table 5 - Fuse requirements for transformers with only primary fusing

Primary Winding	
Rated Amperes [A]	Overcurrent [% of rated FLC]
9 or more	125
2...8.99	167
less than 2	500

Basic Motor Control Circuits

Section 430.72 states that motor control circuits tapped from the load side of a motor branch-circuit short-circuit and ground-fault protective device and functioning to control the motor that is connected to that branch circuit shall be protected against overcurrent in accordance with 430.72. A control circuit in this configuration is not considered a branch circuit, and so you can use either a supplementary fuse or branch circuit protective device(s).

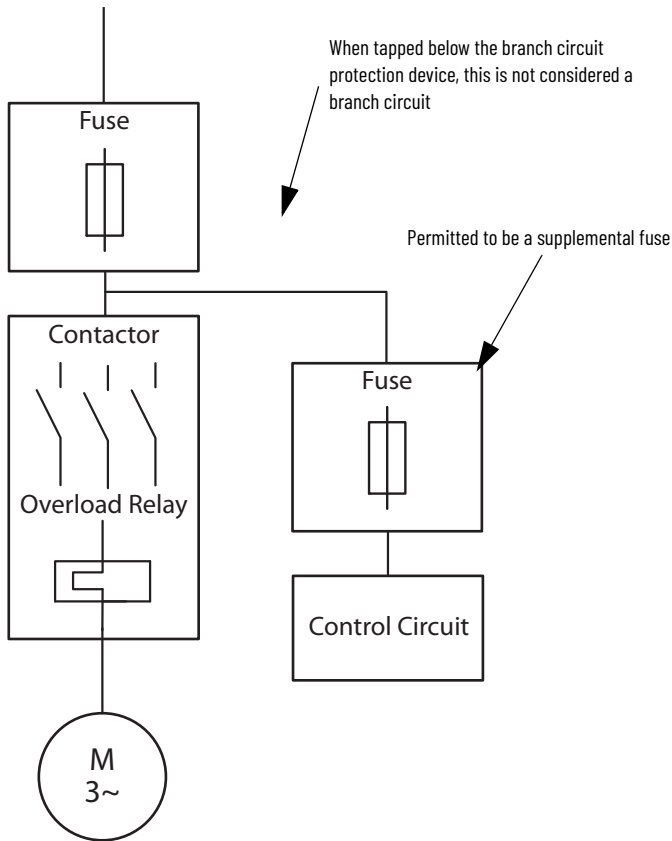

Introduction

This section explains common applications and exceptions when you select and size a motor disconnecting means.

Figure 30 - NEC Article 430 Contents

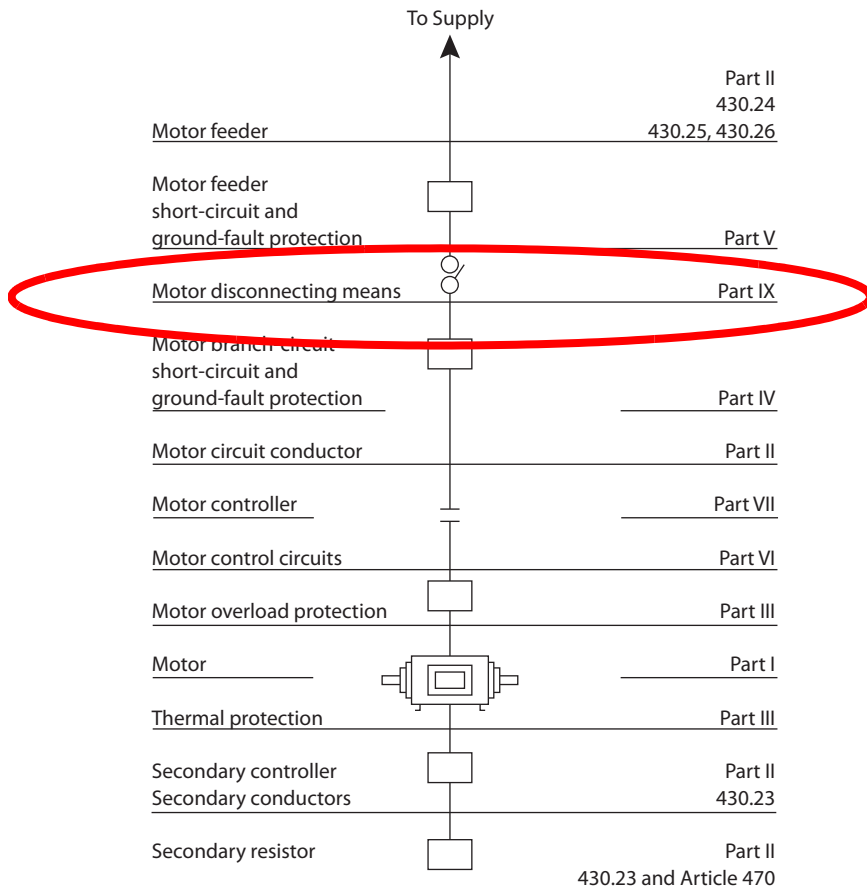

General Considerations

To gain a better understanding of the requirements for motor disconnecting means, refer to *NEC* Article 430, Part IX, which is “intended to require disconnecting means capable of disconnecting motors and controllers from the circuit.”

According to Section 430.102, a disconnecting means must be provided for each controller in the circuit and be located within sight of the controller. You must also provide a disconnecting means for each motor, and it be located within sight of both the motor and driven machinery, as shown in [Figure 31](#).



In this scenario, the driven machinery does not need to be located within sight of the motor.

Figure 31 - Motor Disconnecting Means

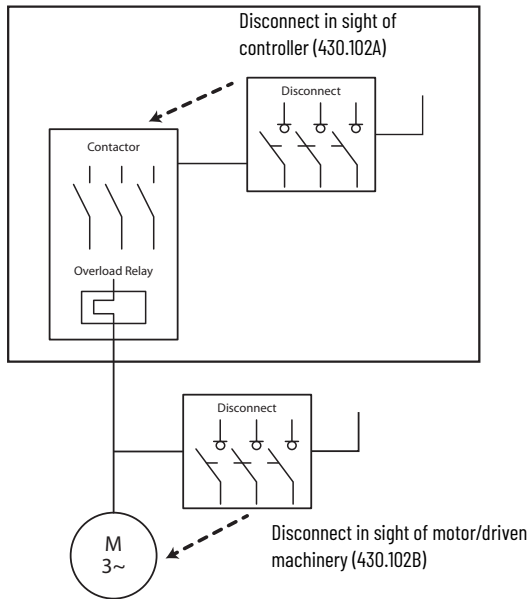

One Disconnect for Both Controller and Motor

According to Section 430.102(B)2, an installation is allowed to use a single disconnect for both the motor and controller as long as the disconnect is within sight of both the motor and the driven machinery location. Article 100 defines “in sight” as both visible and within 50 feet of the motor.

Figure 32 - Motor within Sight of Disconnect

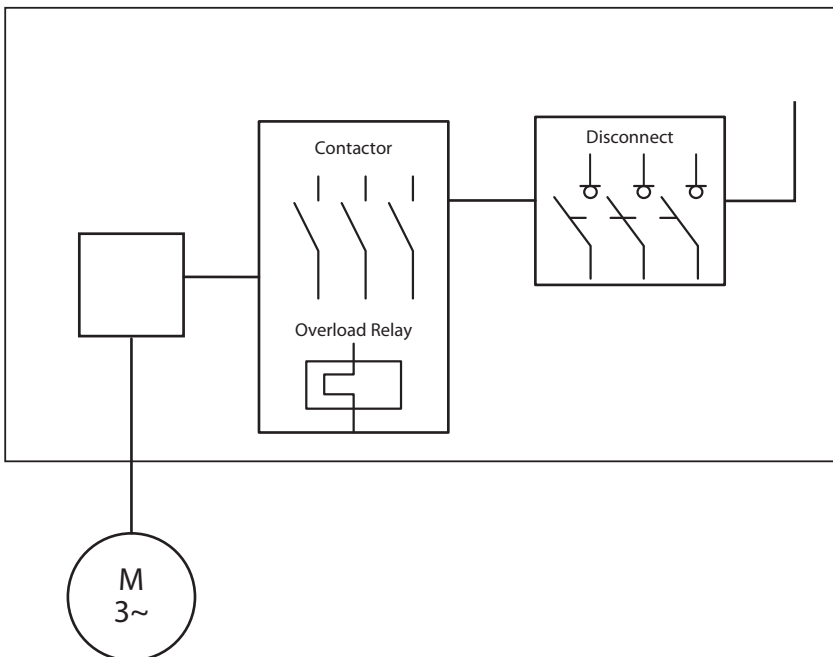

Introduction

When using adjustable-speed drives in motor circuit applications, you must follow the requirements set out in Parts I ...IX, unless the specific requirements for Part X modify them.

Drive Requirements

[Figure 33](#) illustrates some of the basic requirements for an adjustable-speed drive (ASD).

Figure 33 - Adjustable-speed Drive Requirements

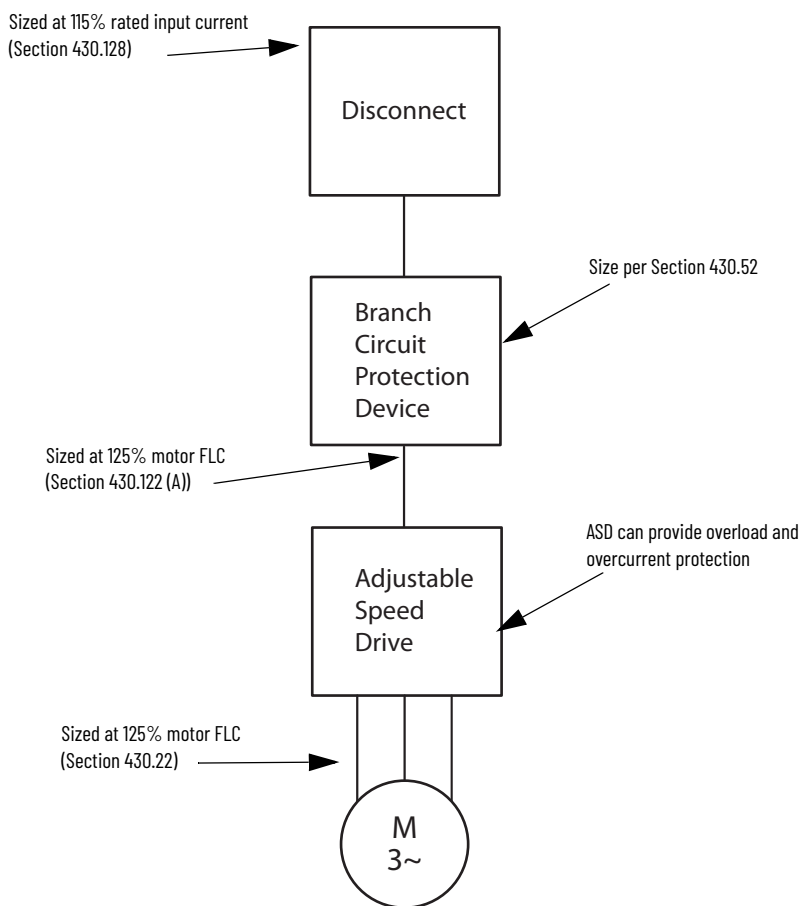

Multiple motor applications

Multiple motor drive applications require that each motor is separately protected by either a circuit breaker or a fuse. Type E Self-Protected devices are not allowed.

Figure 34 - Multiple motor drive applications



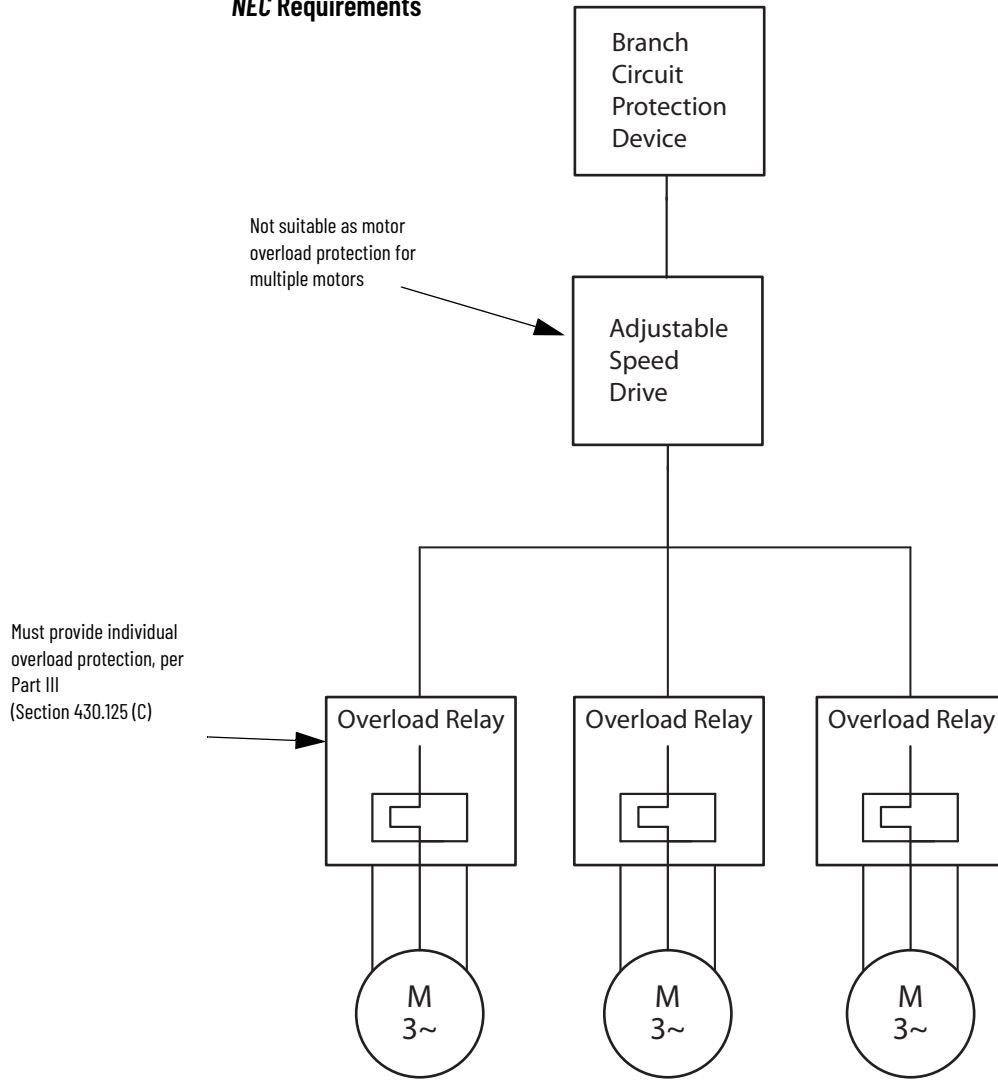



NEC Requirements



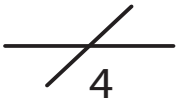
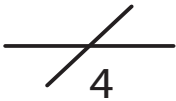





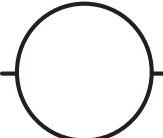
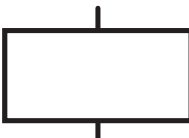

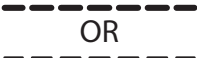

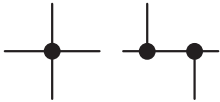
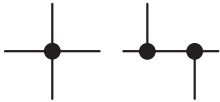
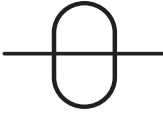
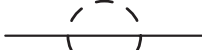
IEC and NEMA Comparison

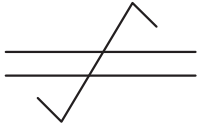







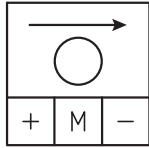
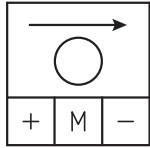

When comparing IEC and NEMA/UL wiring diagrams, it is important to note that there are differences in the symbols that are used to denote components of an electrical schematic. Whether it is a complex control system or a simple across-the-line motor starter, the need to recognize and understand these symbols is more important than ever. It is possible that products from all parts of the world are being used in any one facility.

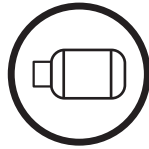
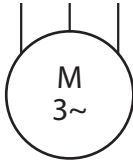
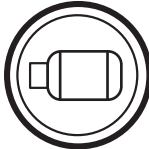
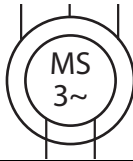



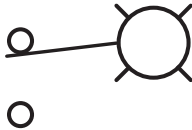

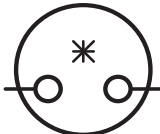
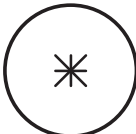



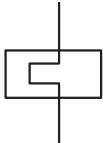
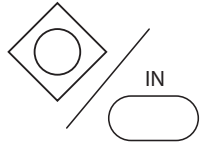
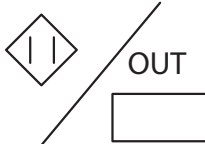
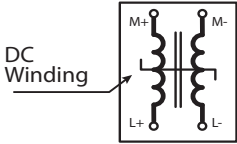

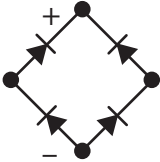
The following tables provide a side-by-side comparison of IEC and NEMA/UL symbology.

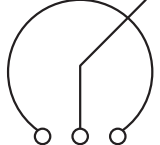
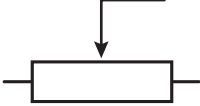

Description		NEMA/UL	IEC
Bus bar	Copper		
Cable, multiconductor			
Capacitor			
Circuit Breaker	control/power		
Coil	blowout		
	operating		



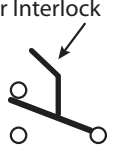



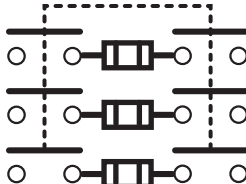
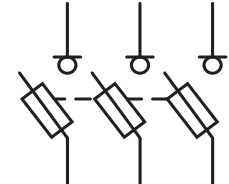
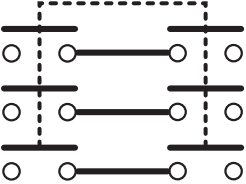
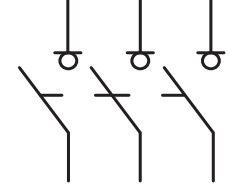
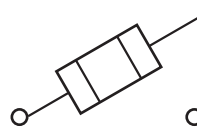

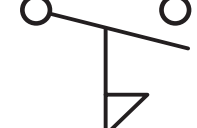
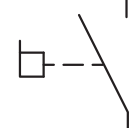
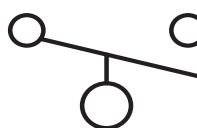
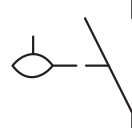
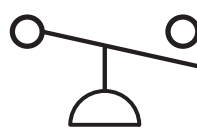
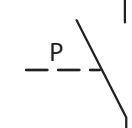
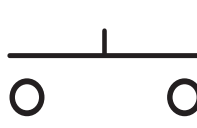
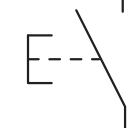
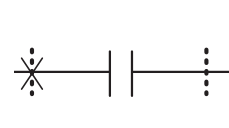
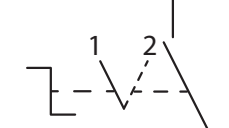
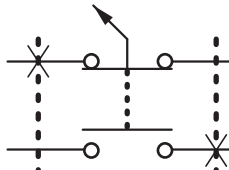
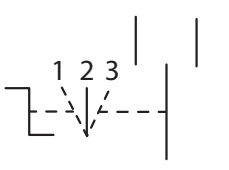
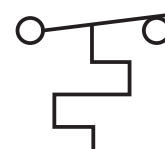
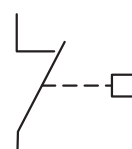

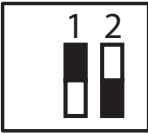
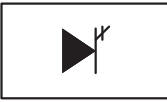
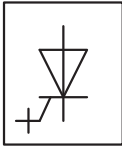
Description		NEMA/UL	IEC
Conductor	or conductive path		
	associated or future		
	crossing of paths or conductors not connected		
	junction of connected paths (conductors or wires)		
	shielded – single or multi-conductor		
	twisted		
Connector	separable or jacks engaged		
Contact,	N.C. (break)		
Contact,	N.O. (make)		



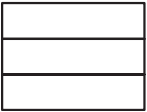
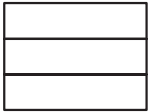

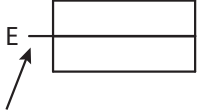
Description		NEMA/UL	IEC
Contact, time delay	normally open with time delay closing		
	normally open with time delay opening		
	normally closed with time delay closing		
	normally closed with time delay opening		
Diode	semiconductor		
Fan	3-phase induction motor		
	1-phase induction motor		
Fuse	control/power		
PE Ground	chassis or frame ground		
Ground	signal		

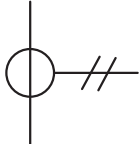
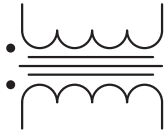
Description		NEMA/UL	IEC
Hall effect current sensor			
Heat sink			
IEEE Number for protective device			
Induction machine	standard		
	synchronous		
Key interlock	on isolation switch or breaker		
	on MV door		
Light, indicating	pilot, signaling, or switchboard		
	push-to-test		
Mechanically connected			
Meter	**# indicates function of meter		
Note number indicator			

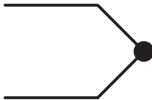
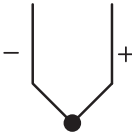
Description		NEMA/UL	IEC
Overload relay, thermal			
PLC	input		
	output		
Reactor	saturable core		
Receptacle			
Rectifier	full wave bridge		
	silicon controlled		
Resistor	adjustable (potentiometer)		
	general		
Switch	single throw		
	toggle (maintained position) – transfer, single pole, 2 position		

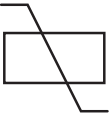
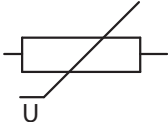
Description	NEMA/UL	IEC
disconnect (fused)		
disconnect (non-fused)		
fused		
flow – actuated, closes on increase in flow		
liquid level – actuated (float), closes when level rises		
pressure or vacuum operated – closes when pressure rises		
push button – momentary, circuit closing (make)		
selector (multi-position) – with contact closed indicator. "X" indicates contacts close		
selector (multi-position) – with push button type contact mechanism. "X" indicates contacts close		
temperature actuated – opening on rising temperature		

Description		NEMA/UL	IEC
Switch	shading indicates that switch is closed		
Symmetrical gate	commutated thyristor and gate driver board		
Surge suppressor			
Terminal			
Terminal block			
Terminal block barrier			
Terminal block end barrier			
Thermistor			
Transformer	current		
	with magnetic core		
Thermocouple			

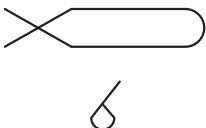
Description		NEMA/UL	IEC
Varistor			
Winding			
Wiring	logic		
	temporary		
Wire gauge marker			

Introduction

The examples on the following pages are intended to help you apply the techniques that are discussed in this application guide when you design and specify components for motor power circuits. The schematic that is used in these exercises is based on *NEC* Section 430.

Example 1 – Feeder Conductor Sizing

Given the configuration in the following illustration, what size conductor (copper wire) is most appropriate? Assume an operating temperature of 75 °C (167 °F).

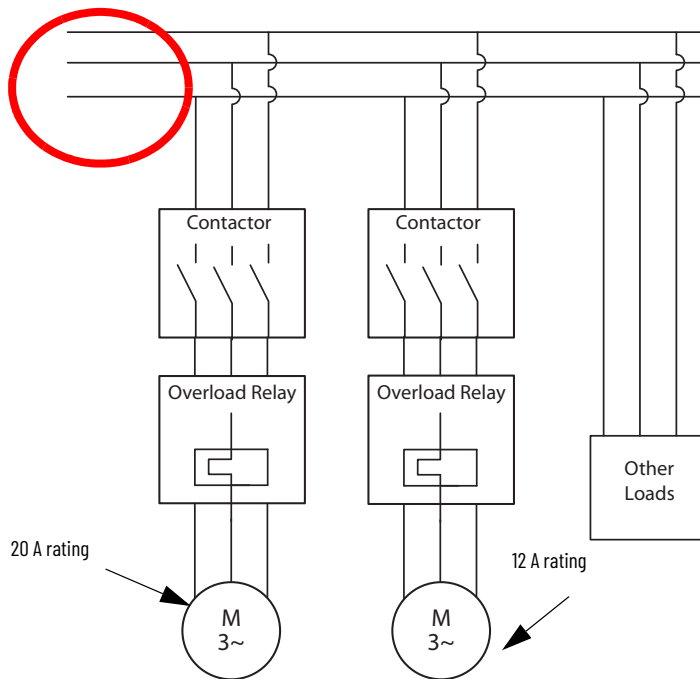

Step 1: Determine total current load

The requirements for feeder conductor sizing state that the conductors must be capable of carrying 125% FLC of the largest motor, in addition to the FLC of all other loads.

For this scenario, our calculation would look like this:

- $(20 \text{ A} \times 1.25) + 12 \text{ A}$

Using these values, we get a total current of **37 A**.

Step 2: Determine appropriate wire size

Next use *NEC* Article 310, Table 310.15(B)(16), to determine the ampacity of the conductor.

Figure 35 - NEC Article 310, Table 310.15(B)(16)

Table 310.15(B)(16) (formerly Table 310.16) Allowable Ampacities of Insulated Conductors Rated Up to and Including 2000 Volts, 60°C Through 90°C (140°F Through 194°F), Not More Than Three Current-Carrying Conductors in Raceway, Cable, or Earth (Directly Buried), Based on Ambient Temperature of 30°C (86°F)

Size AWG or kcmil	Temperature Rating of Conductor [See Table 310.104(A).]						Size AWG or kcmil
	60°C (140°F)	75°C (167°F)	90°C (194°F)	60°C (140°F)	75°C (167°F)	90°C (194°F)	
	Types TW, UF	Types RHW, THHW, THWN, XHHW, USE, ZW	Types TBS, SA, SIS, FEP, FECP, MI, RHH, RHW-2, THHN, THHW, THW-2, THWN-2, USE-2, XHH, XHHW, XHHW-2, ZW-2	Types TW, UF	Types RHW, THHW, THWN, XHHW, USE	Types TBS, SA, SIS, THHN, THHW, THW-2, THWN-2, RHH, RHW-2, USE-2, XHH, XHHW, XHHW-2, ZW-2	
COPPER			ALUMINUM OR COPPER-CLAD ALUMINUM				
18**	—	—	14	—	—	—	—
16**	—	—	18	—	—	—	—
14**	15	20	25	—	—	—	—
12**	20	25	30	15	20	25	12**
10	30	35	40	25	30	35	10**
8	40	50	55	35	40	45	8

Because our calculated value of 37 A falls between two values on the table, we must choose the next largest ampacity, which in this case is 50. Following the row across, we can see that this results in a wire size of **8 AWG**.

Example 2 – Standard Short-Circuit Protection

Given a 7.5 Hp 3-phase motor operating at 460V AC, what is the maximum size circuit breaker that is allowed?

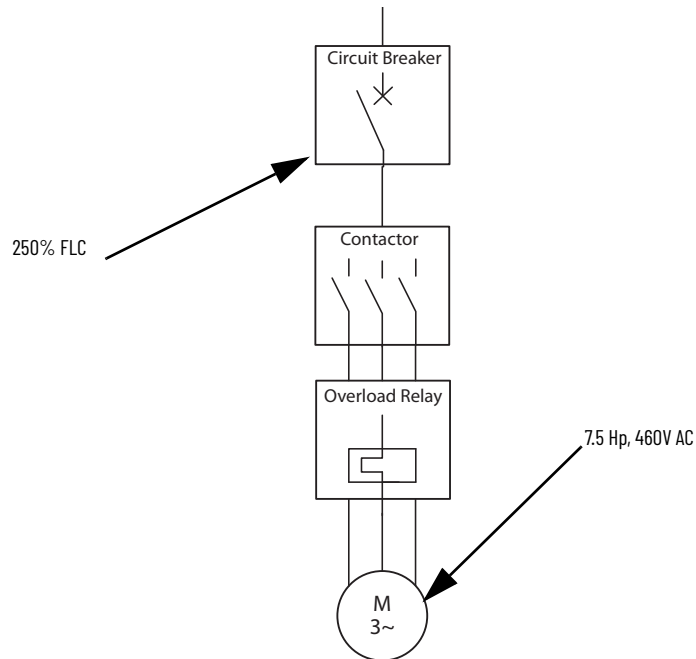

Step 1: Determine the motor FLC

Using Table 430.250, determine the motor FLC. Remember that we are sizing a 7.5 Hp motor at 460V AC.

Horsepower	115 Volts	200 Volts	208 Volts	230 Volts	460 Volts	575 Volts	2300 Volts
1/2	4.4	2.5	2.4	2.2	1.1	0.9	—
3/4	6.4	3.7	3.5	3.2	1.6	1.3	—
1	8.4	4.8	4.6	4.2	2.1	1.7	—
1 1/2	12.0	6.9	6.6	6.0	3.0	2.4	—
2	13.6	7.8	7.5	6.8	3.4	2.7	—
3	—	11.0	10.6	9.6	4.8	3.9	—
5	—	17.5	16.7	15.2	7.6	6.1	—
7 1/2	—	25.2	24.2	22.2	11	9	—

As shown in the table above, the correct FLC for this motor is **11 A**.

Step 2: Find the maximum breaker size

From Table 430.52, find the maximum circuit breaker rating for standard short-circuit protection.

Table 430.52 Maximum Rating or Setting of Motor Branch-Circuit Short-Circuit and Ground-Fault Protective Devices

Type of Motor	Percentage of Full-Load Current			
	Nontime Delay Fuse ¹	Dual Element (Time-Delay) Fuse ¹	Instantaneous Trip Breaker	Inverse Time Breaker ²
Single-phase motors	300	175	800	250
AC polyphase motors other than wound-rotor	300	175	800	250
Squirrel cage — other than Design B energy-efficient	300	175	800	250
Design B energy-efficient	300	175	1100	250
Synchronous ³	300	175	800	250
Wound rotor	150	150	800	150
Direct current (constant voltage)	150	150	250	150

As shown above, the maximum rating for any standard 3-phase motor is 250% FLC. We then multiply the motor FLC by 250%

- 11 A x 2.5 = **27.5 A**

Step 3: Determine final circuit breaker size

Using the list of standard ampere ratings for fuses and circuit breakers, determine the correct circuit breaker size.

Table 6 - Standard Ampere Ratings for Fuses and Fixed-trip circuit breakers

Standard Ampere Ratings [A]					
15	50	110	250	600	2000
20	60	125	300	700	2500
25	70	150	350	800	3000
30	80	175	400	1000	4000
35	90	200	450	1200	5000
40	100	225	500	1600	6000
45	-				
Additional standard ratings for fuses [A]					
1	3	6	10	601	

The breaker size is 27.5, which is between two values according to [Table 6](#). We must round up to the next size, giving us a final solution of a **30 A** breaker.

Example 3 – Exception for when maximum circuit protection sizing is insufficient for starting the motor

Given a 7.5 Hp 3-phase motor operating at 460V AC, if the maximum circuit breaker rating is not sufficient for the starting current of the motor, what additional sizing is permitted?

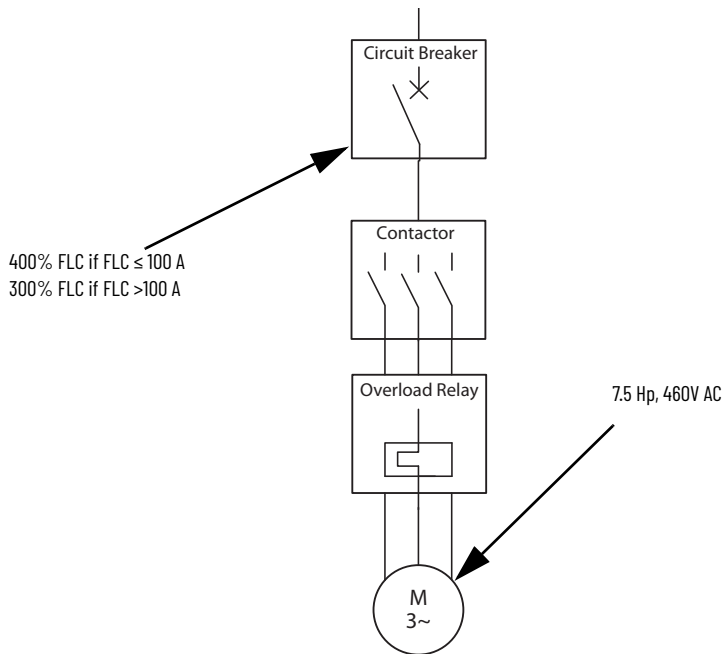

Step 1: Determine the motor FLC

Using Table 430.250, determine the motor FLC. Remember that we are sizing a 7.5 Hp motor at 460V AC.

Induction-Type Squirrel Cage and Wound Rotor (Amperes)							
Horsepower	115 Volts	200 Volts	208 Volts	230 Volts	460 Volts	575 Volts	2300 Volts
½	4.4	2.5	2.4	2.2	1.1	0.9	—
¾	6.4	3.7	3.5	3.2	1.6	1.3	—
1	8.4	4.8	4.6	4.2	2.1	1.7	—
1½	12.0	6.9	6.6	6.0	3.0	2.4	—
2	13.6	7.8	7.5	6.8	3.4	2.7	—
3	—	11.0	10.6	9.6	4.8	3.9	—
5	—	17.5	16.7	15.2	7.6	6.1	—
7½	—	25.2	24.2	22.0	11	9	—

As shown in the table above, the correct FLC for this motor is **11 A**.

Step 2: Find the permitted current rating that is allowed for additional motor starting current

From the exceptions listed in Section 430.52 (c)(1), find the correct circuit breaker setting for standard short-circuit protection. With an FLC of 11 A, this application falls under the **400% FLC** exception. We then multiply the motor FLC by 400%

- 11 A x 4 = 44 A

Step 3: Determine final circuit breaker size

Using the list of standard ampere ratings for fuses and circuit breakers, determine the correct circuit breaker size.

Table 7 - Standard Ampere Ratings for Fuses and Fixed-trip circuit breakers

Standard Ampere Ratings [A]					
15	50	110	250	600	2000
20	60	125	300	700	2500
25	70	150	350	800	3000
30	80	175	400	1000	4000
35	90	200	450	1200	5000
40	100	225	500	1600	6000
45	—				
Additional standard ratings for fuses [A]					
1	3	6	10	601	

The breaker size is 44 A, which is between two values according to [Table 7](#). Because 44 is the maximum value that is allowed, we cannot round up. In this case, we round **DOWN** to **40 A**.

The following terms and abbreviations are used throughout this manual.

- AC contactor** An alternating current (AC) contactor establishes or interrupts an AC power circuit.
- Adjustable-speed Drive** A drive comprised of the motor, drive controller, and operator's controls (either manual or automatic). Also known as an adjustable-frequency drive or variable-frequency drive (VFD).
- Altitude** The atmospheric altitude (height above sea level) at which the motor operates; NEMA standards call for an altitude not to exceed 1000 meters (3300 feet). As the altitude increases above 1000 meters (3300 feet) and the air density decreases, the air's ability to cool the motor decreases. For higher altitudes, higher grades of insulation or motor derating are required. DC motors require special brushes for operation at high altitudes.
- Ambient temperature** The temperature of the surrounding cooling medium, such as gas or liquid, which comes into contact with the heated parts of the motor. The cooling medium is usually the air that surrounds the motor. The standard NEMA rating for ambient temperature is not to exceed 40 °C (104 °F).
- American National Standards Institute (ANSI)** American National Standards Institute. An organization that develops and publishes voluntary industry standards in the United States.
- American wire gauge (AWG)** A standard system that is used for designating the size of electrical conductors. Gauge numbers have an inverse relationship to size; larger numbers have a smaller cross-sectional area. However, a single-strand conductor has a larger cross-sectional area than a multi-strand conductor of the same gauge, so that they have the same current-carrying specification.
- Approved** Use of this term indicated that the device has been found acceptable by the authority having jurisdiction.
- Architecture** Specific configuration of hardware and software elements in a system.
- Authority Having Jurisdiction** The entity that has authority to enforce the requirements of a code or standard, or to approve equipment, materials, installations, or procedures.
- ASD** Adjustable-speed drive.
- Branch circuit** The conductors and components following the last overcurrent protective device protecting a load (as defined in UL 508A).
- Branch circuit protection** Overcurrent protection with an ampere rating selected to protect the branch circuit. For a motor branch circuit, the overcurrent protection is required for overcurrents due to short circuits and faults to ground only (as defined in UL 508A).
- Branch circuit protective device** A fuse or circuit breaker that has been evaluated to a safety standard for providing overcurrent protection (as defined in UL 508A).
- Circuit Breaker** A device that is designed to open and close a circuit by non-automatic means, and to open the circuit automatically on a pre-determined overcurrent, without damage to itself when properly applied within its rating.

Class 1 circuit	A control circuit on the load side of overcurrent protective device where the voltage does not exceed 600 volts, and where the power available is not limited, or control circuit on the load side of power limiting supply, such as a transformer (as defined in UL 508A).
Class 1 wiring	Conductors of a Class 1 Circuit (as defined in UL 508A).
Class 2 circuit	A control circuit that is supplied from a source having limited voltage ($30 V_{\text{rms}}$ or less) and current capacity, such as from the secondary of a Class 2 transformer, and rated for use with Class 2 remote-control or signaling circuits (as defined in UL 508A).
Coil	1.) The electrical conductors wound into the core slot of a motor, electrically insulated from the iron core. A group of coils are connected into circuits, or windings, that carry independent current. These coils carry and produce a magnetic field when current passes through them. 2.) A ladder diagram symbol that represents an output instruction.
Combination motor controller	One or more devices that are assembled to provide disconnecting means, branch circuit protection, motor control, and motor overload protection for a single motor circuit (as defined in UL 508A).
Compensation	Adjustment or alteration of a control system to improve performance. A compensator can be an electrical, mechanical, hydraulic, or pneumatic device.
Conductor	A material, such as copper or aluminum, that offers low resistance or opposition to the flow of electric current.
Conduit box	The metal container usually on the side of the motor where the stator (winding) leads are attached to leads that connect to the power supply.
Control circuit	A circuit that carries the electric signals that direct the performance of a controller, and which does not carry the main power circuit. A control circuit is, in most cases, limited to 15 amperes (as defined in UL 508A).
Control circuit transformer	A transformer whose secondary supplies power to control circuit devices only (excluding loads) (as defined in UL 508A).
Controller	A device or group of devices that serves to govern, in some predetermined manner, the electric power that is delivered to the apparatus to which it is connected (as defined in UL 508A).
DC contactor	A contactor designed to establish or interrupt a direct-current (DC) power circuit.
DC motor	A motor using either generated or rectified DC power. A DC motor is often used when variable-speed operation is required.
Disconnecting means	A device that disconnects all ungrounded conductors of a circuit from their electrical supply (as defined in UL 508A).
Frame	1.) The supporting structure for the stator parts of an AC motor. In a DC motor, the frame usually forms a part of the magnetic coil. The frame also determines mounting dimensions. 2.) The unit exchanged at the data link layer of a communication network.
Frame size	Refers to a set of physical dimensions of motors as established by NEMA. These dimensions include critical mounting dimensions. NEMA 48 and 56 frame motors are considered fractional

horsepower sizes even though they can exceed 1 Hp. NEMA 143T to 449T is considered integral horsepower AC motors and 5000 series and above are called large motors. (For definition of letters following frame number, see [“Suffixes to NEMA frames” on page 57](#).)

Feeder circuit	The conductors and circuitry on the supply side of the branch circuit overcurrent protective device (as defined in UL 508A).
Field-installed equipment	Devices to be installed after an industrial control panel is built/ labeled (as defined in UL 508A).
Field wiring terminal	A terminal provided in an industrial control panel to terminate field wiring (as defined in UL 508A).
Frequency	The rate at which alternating current makes a complete cycle of reversals. It is expressed in cycles per second. In the U.S., 60 cycles (Hz) is the standard while in other countries 50 Hz (cycles) is common. The frequency of the AC current affects the speed of a motor.
Full-load current (FLC); Full-load Amperage (FLA)	The current flowing through the line when the motor is operating at full-load torque and full-load speed with rated frequency and voltage that is applied to the motor terminals.
Full-load torque	The torque necessary to produce the rated horsepower at full-load speed.
Fuse, branch circuit type	A fuse of Class CC, G, H, J, K, L, R, and T. These fuses are able to provide branch circuit protection (as defined in UL 508A).
Fuse, semiconductor type	A fuse designed for the protection of semiconductor devices. These fuses can provide branch circuit protection of motor circuits containing power conversion equipment as in 31.1.3 (as defined in UL 508A).
Fuse, supplementary type	Miscellaneous type and miniature type fuses. These fuses are able to provide supplementary protection only (as defined in UL 508A).
General-purpose motor	A general-purpose motor is any motor having a NEMA “B” design, listed and offered in standard ratings, with standard operating characteristics and mechanical construction for use under usual service conditions without restriction to a particular application or type of application (NEMA).
General-use rating	A rating, expressed in volts and amperes, assigned to a device that is intended to control: <ul style="list-style-type: none"> • A load with a continuous or inrush ampere rating not exceeding the ampere rating of the device; • When AC rated, a load that has a power factor of 0.75 to 0.80 (inductive); and • When DC rated, a load that is resistive (non inductive) (as defined in UL 508A).
Hardware	1) Any mechanical, electrical, and electronic components and assemblies. 2) All the physical components of a control system – including the controller, peripherals, and interconnecting wiring – as opposed to the software components that control its operation. Compare with software (programming).
Horsepower (Hp)	1) Unit of power that represents the amount of work done per unit of time. One horsepower (Hp) is equivalent to lifting 33,000 pounds to a height of one foot in one minute. It is also equal to 746 Watts. 2) The horsepower of a motor is expressed as a function of torque and speed, where torque is measured in units of ft•lb and speed is measured in units of RPM. Calculated as (torque x speed) / 5252.

Induction motor	AC motor that has no electrical connection to the rotor. The current that is supplied to the primary winding on the stator produces a rotating magnetic field in the stator. This rotating magnetic field induces current in the rotor windings. The induced current in the rotor windings creates a magnetic field in the rotor. The interaction of the stator's magnetic field and the rotor's magnetic field causes motion. It runs very close to synchronous speed.
In sight from	Where a standard specifies that equipment shall be "in sight from", "within sight", and so on, the specified equipment must be visible and not more than 15 m (50 ft.) from the other equipment.
Instantaneous trip circuit breaker	A circuit breaker in which no delay is introduced into the tripping action of the circuit breaker. These circuit breakers can provide motor branch circuit protection when evaluated as a part of a combination motor controller as in 31.1.1 (as defined in UL 508A).
Insulation	<ol style="list-style-type: none">1.) Material that tends to resist the flow of electric current and reduce heat loss.2.) In a motor, insulation allows high voltage in the system for current flow and for motor torque production.
International Electrotechnical Commission (IEC)	Global organization that prepares and publishes international standards for all electrical, electronic, and related technologies. These standards serve as a basis for national standardization and as references when drafting international tenders and contracts. The IEC promotes international cooperation on all questions of electrotechnical standardization and related matters, such as the assessment of conformity to standards, in the fields of electricity, electronics, and related technologies.
Interrupting Rating	The highest current, at rated voltage, that a device is intended to interrupt under standard test conditions.
Inverse-time circuit breaker	A circuit breaker in which a delay is introduced into the tripping action of the circuit breaker. The delay decreases as the magnitude of the current increases. These circuit breakers can provide branch circuit protection (as defined in UL 508A, December 28, 2007).
Inverter	<ol style="list-style-type: none">1.) An inverter is an AC-powered adjustable-speed drive.2.) Particular section of an AC drive that uses the DC voltage from a previous circuit stage (intermediate DC circuit) to produce a pulse-width-modulated, stepped AC current, or voltage waveform that has characteristics similar to the desired sine-wave frequency.3.) Circuit whose output signal is the inverse of its input (a positive-going pulse is inverted to a negative-going pulse, and vice versa).4.) Electronic device that converts fixed frequency and fixed voltages to variable frequency and voltage. Lets you electrically adjust the speed of an AC motor.
Isolated secondary circuit	A circuit derived from an isolating source (such as a transformer, optical isolator, limiting impedance, or electro-mechanical relay) and having no direct connection back to the primary circuit (other than through the grounding means). A secondary circuit that has a direct connection back to the primary circuit is evaluated as part of the primary circuit (as defined in UL 508A).
Listed	Equipment, materials, or services included in a list that is acceptable to the authority having jurisdiction.

- Load**
- 1) Burden that is imposed on a motor by the driven machine. It is often stated as the torque required to overcome the resistance of the machine it drives. Sometimes synonymous with “required power”.
 - 2) Share of work that is demanded of a machine or system. It is the external force that is applied to a machine or system, or the sum of the external forces and the weight of the structure moved by the machine or system.
 - 3) Amount of power or current needed to start or maintain motion in a power-driven machine or apparatus.
 - 4) External mechanical resistance against which a machine acts.
 - 5) Machine characteristics that are to be moved from one place to another.
 - 6) Function of mass, moment of inertia, static and dynamic forces supported by the robot. It is expressed as the force and torque at the mechanical interface which can be exerted along the various axes of motion under specified conditions of velocity and acceleration.
- Locked-rotor current** Amount of current drawn at the instant a motor is energized. It is the steady-state current that is taken from a line with a rotor that is at standstill with rated voltage and frequency. In most cases, it is much higher than the current required for running a motor. It is also known as starting current.
- Low-voltage limited energy circuit** A control circuit involving a peak open-circuit potential of not more than 42.4 volts (DC or peak) supplied by a primary battery or by an isolated secondary circuit, and where the current capacity is limited by an overcurrent device, such as a fuse, or by the inherent capacity of the secondary transformer or power supply, or a combination of a secondary winding and an impedance. A circuit that is derived from a line-voltage circuit by connecting a resistance in series with the supply circuit to limit the voltage and current is not identified as a low-voltage limited energy circuit (as defined in UL 508A).
- Motor** A device that takes electrical energy and converts it into mechanical energy to turn a shaft.
- Motor overload** Electrical overload, a situation where an electrical machine or system is subjected to a greater load than that for which it was designed.
- Motor rating** A motor’s operational capabilities. They are specifications or performance limits that are measured at defined temperatures.
- Nameplate** The plate on the outside of the motor that describes the motor horsepower, voltage, speed efficiency, design, enclosure, and other characteristics.
- National Electrical Code® (NEC®)** A set of regulations governing the construction and installation of electrical wiring and apparatus, which is established by the National Fire Protection Association and suitable for mandatory application by governing bodies exercising legal jurisdiction. It is widely used by state and local authorities within the United States.
- National Electrical Manufacturers Association (NEMA)** A non-profit organization that is organized and supported by manufacturers of electric equipment and supplies. NEMA has set standards for: horsepower ratings, speeds, frame sizes and dimensions, standard voltages and frequencies with allowable variations, service factors, torque, starting current & kVA, and enclosures.

Original Equipment Manufacturer (OEM)	The maker of a piece of equipment. An example would be a machine tool manufacturer who buys programmable controller components, sensors, and actuators—then integrates them with their machine tool to produce the complete system for sale to the end user.
Overcurrent protection	A device that is designed to open a circuit when the current through it exceeds a predetermined value. The ampere rating of the device is selected for a circuit to terminate a condition where the current exceeds the rating of conductors and equipment due to overloads, short circuits, and faults to ground (as defined in UL 508A).
Overload	An electrical load that exceeds the available electrical power.
Overload protection	Protection required for motor circuits that operates to prohibit excessive heating due to running overloads and failure to start (as defined in UL 508A).
Phase	1.) Indicates the space relationships of windings and changing values of the recurring cycles of AC voltages and currents. Due to the positioning (or the phase relationship) of the windings, the various voltages and currents were not similar in all aspects at any given instant. Each winding leads or lags another in position. Each voltage leads or lags another voltage in time. Each current leads or lags another current in time. The most common power supplies are either single- or three-phase (with 120 electrical degrees between the three phases). 2.) The separation in electrical degrees between any specified transitions of any two channels in an encoder.
Power	The work done per unit of time. Measured in horsepower or watts: 1 Hp= 33,000 ft•lb/min. = 746 W.
Power factor	The ratio of the active power (W) to the apparent power (VA) expressed as a percentage. It is numerically equal to the cosine of the angle of lag of the input current with respect to its voltage, multiplied by 100.
Power transformer	A transformer whose secondary winding supplies power to loads or a combination of loads and control circuit devices operating at the secondary voltage (as defined in UL 508A).
Qualified person	A person who has the skills and knowledge about to the construction and operation of electrical equipment and installations and has received safety training to recognize and avoid the hazards that are involved.
Rated horsepower	The maximum or allowable power output of a motor or other prime mover under normal, continuous operating conditions.
Receptacle	A contact device installed at the outlet for the connection of an attachment plug. A single receptacle is a single contact device with no other contact device on the same yoke. A multiple receptacle is two or more contact devices on the same yoke.
Safe working procedure	A method of working that reduces risk.
Self-protected combination motor controller	A self-protected combination motor controller that is operable only by manual means. A combination motor controller that contains coordinated overload and short circuit protection, and also provides disconnecting means and remotely operable motor controller. Coordinated protection is able to be inherent or obtained by correct selection of components or accessory parts in accordance with the manufacturer's instructions (as defined in UL 508A).

Service Factor (SF) 1) When used on a motor nameplate, a number that indicates how much above the nameplate rating a motor can be loaded without causing serious degradation (for example, a 1.15 SF can produce 15% greater torque than the 1.0 SF rating of the same motor).

2) When used in applying motors or gear motors, a figure of merit, which is used to “adjust”, measured loads in an attempt to compensate for conditions that are difficult to measure or define. Typically, measured loads are multiplied by service factors (experience factors) and the result in an “equivalent required torque” rating of a motor or gear motor.

Shall Indicates a mandatory requirement in regulatory standards.

Short-circuit current An overcurrent resulting from a short circuit due to a fault or an incorrect connection.

Short-circuit current rating (SCCR) The prospective symmetrical fault current at a nominal voltage to which an apparatus or system is able to be connected without sustaining damage exceeding the defined acceptance criteria (as defined in UL 508A).

Suffixes to NEMA frames Letter suffixes sometimes follow the NEMA frame size designations. Some of these suffixes, according to NEMA standards, have the following meanings:

Fractional Horsepower Motors

- C Face mounting
- G Gasoline pump motor
- H Indicates a frame having a larger “F” dimension
- J Jet pump motor
- Y Special mounting dimensions (see manufacturer)
- Z All mounting dimensions are standard except the shaft extension

Integral Horsepower Motors

- A DC motor or generator
- C Face mounting on drive end
- D Flange mounting on drive end
- P Vertical hollow and solid shaft motors with P-Base flange
- HP Vertical solid shaft motors with P-Base flange (normal thrust)
- JM Close-coupled pump motor with C-Face mounting and special shaft extensions
- JP Close-coupled pump motor with C-Face mounting and special long shaft extension
- LP Vertical solid shaft motors with P-Base flange (medium thrust)
- S Standard short shaft for direct connection
- T Standardized shaft –“T” frame
- V Vertical mounting
- Y Special mounting dimensions
- Z All mounting dimensions standard except shaft extension

Supplementary protection A device intended to provide additional protection subsequent to branch circuit protection. They have not been evaluated for providing branch circuit protection (as defined in UL 508A).

Supplementary protector A manually resettable device that is designed to open the circuit automatically on a predetermined value of time versus current or voltage within an appliance or other electrical equipment. It is also able to be provided with manual means for opening or closing the circuit. These devices can provide supplementary protection only (as defined in UL 508A).

Tap conductor A conductor (other than a service conductor) that has overcurrent protection ahead of its point of supply that exceeds the value that is permitted for similar conductors.

UL (Underwriter's Laboratories) An independent testing organization, which examines and tests devices, systems and materials with particular reference to life, fire, and casualty hazards. It develops standards for motors and controls through cooperation with manufacturers.

Voltage, nominal A nominal value that is assigned to a circuit or system for the purpose of conveniently designating its voltage class.

Watt The amount of power required to maintain a current of one ampere at a pressure of one volt. Most motors are rated in kW, equal to 1,000 Watts. One horsepower is equal to 746 Watts.

Additional Resources

These documents contain additional information concerning related products from Rockwell Automation.

Resource	Description
Rockwell Automation Global SCCR Tool, rok.auto/sccr	Provides coordinated high-fault branch circuit solutions for motor starters, soft starters, and component drives.
Industrial Components Preventive Maintenance, Enclosures, and Contact Ratings Specifications, publication IC-TD002	Provides a quick reference tool for Allen-Bradley industrial automation controls and assemblies.
Safety Guidelines for the Application, Installation, and Maintenance of Solid-state Control, publication SGI-1.1	Designed to harmonize with NEMA Standards Publication No. ICS 1.1-1987 and provides general guidelines for the application, installation, and maintenance of solid-state control in the form of individual devices or packaged assemblies incorporating solid-state components.
Industrial Automation Wiring and Grounding Guidelines, publication 1770-4.1	Provides general guidelines for installing a Rockwell Automation industrial system.
Product Certifications website, rok.auto/certifications .	Provides declarations of conformity, certificates, and other certification details.

You can view or download publications at rok.auto/literature.

Rockwell Automation Support

Use these resources to access support information.

Technical Support Center	Find help with how-to videos, FAQs, chat, user forums, and product notification updates.	rok.auto/support
Knowledgebase	Access Knowledgebase articles.	rok.auto/knowledgebase
Local Technical Support Phone Numbers	Locate the telephone number for your country.	rok.auto/phonesupport
Literature Library	Find installation instructions, manuals, brochures, and technical data publications.	rok.auto/literature
Product Compatibility and Download Center (PCDC)	Download firmware, associated files (such as AOP, EDS, and DTM), and access product release notes.	rok.auto/pcdc

Documentation Feedback

Your comments help us serve your documentation needs better. If you have any suggestions on how to improve our content, complete the form at rok.auto/docfeedback.

Allen-Bradley, expanding human possibility, FactoryTalk, Rockwell Automation, and TechConnect are trademarks of Rockwell Automation, Inc.

NFPA 70, National Electrical Code, and NEC are registered trademarks of the National Fire Protection Association, Quincy, MA.





Trademarks not belonging to Rockwell Automation are property of their respective companies.

Excerpts from UL 508A are copyright Underwriters' Laboratories and are used with permission.

Excerpts from the National Electrical Code are reprinted with permission from NFPA 70[®]-2011, National Electrical Code[®], Copyright © 2010, National Fire Protection Association, Quincy, MA. This reprinted material is not the complete and official position of the NFPA on the referenced subject, which is represented only by the standard in its entirety.

Rockwell Automation maintains current product environmental compliance information on its website at rok.auto/pec.

Rockwell Otomasyon Ticaret A.Ş. Kar Plaza İş Merkezi E Blok Kat:6 34752, İçerenköy, İstanbul, Tel: +90 (216) 5698400 EEE Yönetmeliğine Uygundur

Connect with us.    

rockwellautomation.com ————— expanding **human possibility**[™]

AMERICAS: Rockwell Automation, 1201 South Second Street, Milwaukee, WI 53204-2496 USA, Tel: (1) 414.382.2000, Fax: (1) 414.382.4444

EUROPE/MIDDLE EAST/AFRICA: Rockwell Automation NV, Pegasus Park, De Kleetlaan 12a, 1831 Diegem, Belgium, Tel: (32) 2 663 0600, Fax: (32) 2 663 0640

ASIA PACIFIC: Rockwell Automation, Level 14, Core F, Cyberport 3, 100 Cyberport Road, Hong Kong, Tel: (852) 2887 4788, Fax: (852) 2508 1846