

B-663



KEPCO

POWER SUPPLIES

KEPCO, INC. • 131-38 SANFORD AVENUE • FLUSHING, N.Y. 11352 • Phone: (212) 461-7000

DESIGN GROUP FEATURES CHART

	ABC Pages 6-9	CK Pages 10-11	HB Pages 12-13	KG Pages 14-15	KO Pages 16-17	KS Pages 18-19	OPS Pages 20-21	PAX Pages 22-23	PBX Pages 24-25	PR Pages 26-27	PRM Pages 28-31	PWR Pages 32-33	SM Pages 34-35	WR Pages 36-37
OPERATIONAL PROGRAMMING	●	●	●			●	●	●	●					
HIGH SPEED PROGRAMMING	○						●	●						
REMOTE VOLTAGE CONTROL	●	●	●	●	●	●	●	●	●			●		
REMOTE ERROR SENSING	●	●	○	●	●	●	●	●	●			●	●	
PNP PASS TRANSISTOR	○	●				●	○	●					●	
NPN PASS TRANSISTOR				●			○		●			●		
HYBRID CIRCUITRY	○		●											○
SCR's					●	●								
TEMP. COMPENSATED ZENER REF.	●	●	●	●	●	●	●	●	●			●	●	○
KEPCO BRIDGE	●	●	●	●	●	●	●	●	●			●	●	○
VOLTAGE REGULATION	●	●	●	●	●	●	●	●	●	●	●	●	●	●
CURRENT REGULATION	●	●	●	●	●	●	●	●	●			●		
AUTOMATIC CROSSOVER		●			●	●								
VIX [®] SIGNAL		●				●								
SHORT CIRCUIT PROTECTION	●	●	●	●	●	●	●	●	●	●	●	●	●	●
CURRENT LIMITING	●			●			●	●	●					
CURRENT CUTOFF												●		
FLUX-O-TRAN [®]										●	●	●	●	
FORCED COOLING		●			●	●				●			●	
CONVECTION COOLING	●		●	●			●	●	●		●	●		●
50 or 60 cps INPUT										●	●	●	●	
50-65 cps INPUT		●			●	●								●
50-440 cps INPUT	●		●				●	●	●					
METERS	●	●	●		●	●				●			●	●
10-TURN CONTROL	●	●	●	●	●	●								
BENCH STYLE	●	●	●		●	●	○			●			●	●
MODULAR STYLE				●			●	●	●		●	●		
RACK ADAPTERS	●	●		●			●	●	●		●	●		
AUXILIARY AC OUTPUT	○		●											○
FRONT TERMINALS	●	●	●			○	○			○			●	○

● All models ○ Some Models

ORDERING INFORMATION

All of the power supplies described in this catalog are regular production items, not specials, not "built to order". Our inventory will, at almost any given time, contain substantial quantities of most listed items. Moreover, since all cataloged goods are produced on a regular basis for stock, out-of-stock products can usually be offered on a 30-day maximum basis. Your local Kepco Field Engineering Office receives weekly inventory reports and is equipped to quote price and delivery directly.

Orders:

Please use the Kepco model number to describe the power supply that you want. If your organization has assigned specification control numbers to our standard models, please list our model number also to assist our order processing department in filling your order with least delay. Unless otherwise specified, orders are shipped via motor freight or UPS. Liaison is maintained with all shipping agencies and Metropolitan New York Airports.

Warranty:

All Kepco products are backed by a **valid, unconditional** repair guarantee — for one year after date of sale. Our entire staff of nationwide representative field engineers are factory trained to assist you in obtaining the best performance from each Kepco Power Supply. Each field engineer is prepared to render on-the-spot field service and many of our representative organizations maintain full service centers for overhaul and maintenance. For the address and telephone number of your local Kepco Field Engineer, refer to the back cover of this catalog

Parts:

Recognizing the importance of providing proper equipment support after delivery to our customers, Kepco maintains a complete inventory of every component needed to service any Kepco Power Supply **regardless of age**. When writing to us or to our local field representative organization concerning spare parts, please refer to the model and serial number of the equipment involved. Also give a description of the part and the Kepco part number.

Communications:

Kepco maintains complete communication facilities including postal, telephone, Western Union (WUX) and teletype (TWX) facilities:

Mail Address and WUX..... **131-38 Sanford Ave.,
Flushing, N. Y. 11352**
Telephone Number **(212) IN 1-7000**
TWX Number **212-539-6623**
Cable Address **KEPCOPOWER NEWYORK**



TABLE OF CONTENTS

Design Group Features Chart	Page 2
Ordering Information	Page 2
Index by Output Voltage	Pages 3-4
Kepeco Literature	Page 5
Design Group Listings	Pages 6-37
Nomograph of Voltage Drop	Page 38
Kepeco Accessory Equipment	Pages 39-43
Glossary of Power Supply Terms	Pages 44-49
Applications Notes	Pages 50-51
Kepeco Representatives.....	Page 52

POWER SUPPLY SPECIFICATIONS

ABC All-Transistor GROUP	Pages 6-7
ABC Hybrid GROUP	Pages 8-9
CK GROUP	Pages 10-11
HB GROUP	Pages 12-13
KG GROUP	Pages 14-15
KO GROUP	Pages 16-17
KS GROUP	Pages 18-19
OPS GROUP	Pages 20-21
PAX GROUP	Pages 22-23
PBX GROUP	Pages 24-25
PR GROUP	Pages 26-27
PRM 120 Series GROUP	Pages 28-29
PRM 180 Series GROUP	Pages 28-29
PRM Extra-Filtered GROUP	Pages 30-31
PRM Dual Output GROUP	Pages 30-31
PWR GROUP	Pages 32-33
SM GROUP	Pages 34-35
WR GROUP	Pages 36-37

INDEX BY OUTPUT VOLTAGE

This Index is specially arranged to facilitate the selection of the proper power supply for every job. It complements the *design group* listings by grouping models according to their *voltage rating*. Thus, for example, it is easy to determine which *groups* have models in any desired *voltage range* — and then to examine their comparative specifications in detail. New additions are displayed without tinted background.

INDEX BY OUTPUT VOLTAGE

DC OUTPUT VOLTS	DC OUTPUT AMPS	MODEL	PAGE
0-2	0-1	ABC 2-1M	6-7
0-2	0-8	CK 2-8M	10-11
0-4	0-14	PWR 4-14	32-33
Dual 4.5	0-20	PRM 2X4.5-20	30-31
6.3	0-15	PRM 6-15	28-29
Dual 6.3	0-20	PRM 2X6-20	30-31
6.3	0-25	PRM 6-25	28-29
6.3	0-25	PRM 6-25F	30-31
0-7	0-1	PAX 7-1	22-23
0-7	0-2	OPS 7-2	20-21
0-7	0-2	PBX 7-2	24-25
0-7	0-11	PWR 7-11	32-33
0-7.5	0-2	ABC 7.5-2M	6-7
0-8	0-5	CK 8-5M	10-11
0-8	0-15	KS 8-15M	18-19
0-8	0-25	KS 8-25M	18-19
0-8	0-50	KS 8-50M	18-19
0-8	0-100	KS 8-100M	18-19
0-10	0-0.75	ABC 10-0.75M	6-7
0-12	0-7	PWR 12-7	32-33
0-12	0-100	KO 12-100M	16-17
12	0-10	PRM 12-10	28-29
Dual 12	0-12	PRM 2X12-12	30-31
12	0-15	PRM 12-15	28-29
12	0-15	PRM 12-15F	30-31
0-14	0-7	SM 14-7M	34-35
0-14	0-15	SM 14-15M	34-35
0-14	0-30	SM 14-30M	34-35
0-15	0-0.75	PAX 15-0.75	22-23
0-15	0-1	ABC 15-1M	6-7
0-15	0-1.5	OPS 15-1.5	20-21
0-15	0-1.5	PBX 15-1.5	24-25
0-15	0-6	PWR 15-6	32-33
0-7.5-15	0-10	PR 15-10M	26-27
0-15	0-30	PR 15-30M	26-27
Dual 15	0-10	PRM 2X15-10	30-31
0-18	0-0.5	ABC 18-0.5M	6-7
0-18	0-3	CK 18-3M	10-11
0-18	0-10	KS 18-10M	18-19
0-18	0-15	KS 18-15M	18-19
0-18	0-25	KS 18-25M	18-19
0-18	0-50	KS 18-50M	18-19
18	0-6.7	PRM 18-6.7	28-29
Dual 18	0-8	PRM 2X18-8	30-31
18	0-10	PRM 18-10	28-29
18	0-10	PRM 18-10F	30-31
0-20	0-0.05	OPS-1	20-21
0-20	0-100	PR 20-100AM	26-27
0-21	0-0.5	PAX 21-0.5	22-23
0-21	0-1	OPS 21-1	20-21
0-21	0-1	PBX 21-1	24-25
0-24	0-4	PWR 24-4	32-33

INDEX BY OUTPUT VOLTAGE

DC OUTPUT VOLTS	DC OUTPUT AMPS	MODEL	PAGE
24	0-5	PRM 24-5	28-29
Dual 24	0-6	PRM 2X24-6	30-31
24	0-8	PRM 24-8	28-29
24	0-8	PRM 24-8F	30-31
0-25	0-0.2	KG 25-0.2	14-15
0-25	0-50	KO 25-50M	16-17
0-28	0-3.3	PWR 28-3.3	32-33
28	0-4.3	PRM 28-4.3	28-29
Dual 28	0-5	PRM 2X28-5	30-31
28	0-7	PRM 28-7	28-29
28	0-7	PRM 28-7F	30-31
0-30	0-0.3	ABC 30-0.3M	6-7
0-36	0-0.3	PAX 36-0.3	22-23
0-36	0-1.5	CK 36-1.5M	10-11
0-36	0-3	PWR 36-3	32-33
0-36	0-5	KS 36-5M	18-19
0-36	0-5	SM 36-5M	34-35
0-36	0-10	KS 36-10M	18-19
0-36	0-10	SM 36-10M	34-35
0-36	0-15	KS 36-15M	18-19
0-36	0-15	SM 36-15M	34-35
0-36	0-30	KS 36-30M	18-19
36	0-3.3	PRM 36-3.3	28-29
Dual 36	0-4	PRM 2X36-4	30-31
36	0-5	PRM 36-5	28-29
36	0-5	PRM 36-5F	30-31
0-19-38	0-5	PR 38-5M	26-27
0-38	0-15	PR 38-15M	26-27
0-40	0-0.5	ABC 40-0.5M	6-7
0-40	0-0.5	OPS 40-0.5	20-21
0-40	0-0.5	PBX 40-0.5	24-25
0-40	0-0.8	CK 40-0.8M	10-11
0-40	0-50	PR 40-50AM	26-27
0-45	0-30	KO 45-30M	16-17
0-48	0-2	PWR 48-2	32-33
48	0-2.5	PRM 48-2.5	28-29
Dual 48	0-3	PRM 2X48-3	30-31
48	0-4	PRM 48-4	28-29
48	0-4	PRM 48-4F	30-31
0-50	0-40	PR 50-40AM	26-27
0-60	0-0.5	CK 60-0.5M	10-11
0-60	0-1.5	PWR 60-1.5	32-33
0-60	0-2	KS 60-2M	18-19
0-60	0-5	KS 60-5M	18-19
0-60	0-10	KS 60-10M	18-19
0-60	0-20	KS 60-20M	18-19
60	0-2	PRM 60-2	28-29
Dual 60	0-2.5	PRM 2X60-2.5	30-31
60	0-3	PRM 60-3	28-29
60	0-3	PRM 60-3F	30-31
0-70	0-20	KO 70-20M	16-17
0-72	0-0.15	PAX 72-0.15	22-23

INDEX BY OUTPUT VOLTAGE

DC OUTPUT VOLTS	DC OUTPUT AMPS	MODEL	PAGE
0-72	0-0.3	OPS 72-0.3	20-21
0-72	0-0.3	PBX 72-0.3	24-25
0-75	0-2	SM 75-2M	34-35
0-75	0-5	SM 75-5M	34-35
0-75	0-8	SM 75-8M	34-35
0-40-80	0-2.5	PR 80-2.5M	26-27
0-80	0-8	PR 80-8M	26-27
0-100	0-0.1	PAX 100-0.1	22-23
0-100	0-0.2	ABC 100-0.2	6-7
0-100	0-0.2	OPS 100-0.2	20-21
0-100	0-0.2	PBX 100-0.2	24-25
0-120	0-1	KS 120-1M	18-19
0-120	0-2.5	KS 120-2.5M	18-19
0-120	0-5	KS 120-5M	18-19
0-120	0-10	KS 120-10M	18-19
120	0-1	PRM 120-1	28-29
120	0-1.5	PRM 120-1.5	28-29
120	0-1.5	PRM 120-1.5F	30-31
0-78-155	0-1	PR 155-1M	26-27
0-155	0-4	PR 155-4M	26-27
0-160	0-1	SM 160-1M	34-35
0-160	0-2	SM 160-2M	34-35
0-160	0-4	SM 160-4M	34-35
0-200	0-0.1	ABC 200M	8-9
0-220	0-3	PR 220-3M	26-27
0-250	0-1	HB 250M	12-13
Dual 0-300	0-0.075	103 Unregulated	36-37
0-165-310	0-0.6	PR 310-0.6M	26-27
0-310	0-2	PR 310-2M	26-27
0-165-325	0-0.5	SM 325-0.5M	34-35
0-325	0-0.2	HB 2AM	12-13
0-325	0-0.4	HB 4AM	12-13
0-325	0-0.6	HB 6AM	12-13
0-325	0-0.8	HB 8AM	12-13
0-325	0-1	SM 325-1M	34-35
0-325	0-2	SM 325-2M	34-35
0-400	0-0.15	400B + Bias	36-37
Dual 0-400	0-0.15	2400B + Bias	36-37
0-425	0-0.05	ABC 425M	8-9
Dual 0-450	0-0.3	430D	36-37
0-525	0-0.5	HB 525M	12-13
Dual 0-600	0-0.2	800B	36-37
0-600	0-0.3	615B + Bias	36-37
0-600	0-0.5	605 + Bias	36-37
0-1000	0-0.02	ABC 1000M	8-9
0-1000	0-0.5	1250B	36-37
0-1200	0-0.05	1220C	36-37
0-1500	0-0.01	ABC 1500M	8-9
0-1500	0-0.2	1520B	36-37
0-2000	0-0.5	HB 2050	36-37
0-2500	0-0.002	ABC 2500M	8-9
0-2500	0-0.05	HB 2500	36-37



means power supplies!

After two decades of leadership in the power supply industry, our company name and product are to many persons synonymous. Their "Kepco's" are good and faithful laboratory tools, and we're proud of the association. Power supplies are something every scientist and engineer takes for granted — a normal part of the lab complement — and this is as it should be. In both systems and bench applications, the power supplies should function without *excessive* attention or precaution. Kepco devotes considerable effort to making this so.

In a modern context, however, power supplies are increasingly finding service in active roles — beyond the classic task of supplying steady-state power to a load. This catalog, for example, contains specifications for *slewing rate, input offsets, open and closed loop gain, summing, scaling and amplifying* — all of which are characteristic for new *high speed and operational power supplies*. For a fuller appreciation of the capabilities of the modern operational power supply, please refer to the supporting publications listed below.

The Kepco philosophy has been to concentrate its facilities and resources on the development and production of a catalog line of power supplies in such variety as to satisfy as many military/industrial needs as possible. This broad based specialization means that each product can be backed by an extensive test and evaluation program refined by the rigors of high volume production. Such an approach yields substantially more reliable, time-proven products than can possibly be turned out on a custom design basis, no matter how carefully done.

Kepco engineering laboratories, assembly plant, transformer and metal shops, warehouse and offices are housed in two adjacent modern buildings located in Flushing, New York. To maintain the high quality level expected of Kepco Power Supplies, an extensive Quality Control program has been in effect throughout all phases of the development and manufacturing effort. This program, conforming basically to MIL-Q-9858, is approved by leading contractors to the U.S. Military establishment.

KEPCO'S CONTRIBUTIONS TO THE POWER SUPPLY ART*

- Short Circuit Protection by Current Limiting
- New Sharper Current Limiting.
- Automatic Crossover
- VIX® Indicators and Signals
- Operational Power Supplies
- High Speed Slewing
- Hybrid Regulators for High Voltage
- High Efficiency Lateral Cooling
- Efficient Slave Pass Circuits
- Remote Error Sensing
- The Voltage Comparison Bridge Regulator
- The Flux-O-Tran® Static Regulator
- PWR Cutoff Characteristic
- Full Range Regulators
- Thermal Protectors
- Programming Devices
- Function Regulators

*Many advances in power supplies are covered by patents, issued and pending. Applicable patent numbers furnished on request.

KEPCO LITERATURE

This catalog is one of a number of Kepco publications designed to assist you in the selection and application of Regulated Power Supplies. Kepco publications include: "Kepco Power Supply Handbook", reprints of current technical papers and a bi-monthly newspaper, the Kepco Power Supply News.

1. KEPCO POWER SUPPLY HANDBOOK

The Handbook covers the subject of Regulated DC Power Supplies in detail with particular emphasis on the operational concept, and its application to systems design.

2. TECHNICAL PAPERS

Kepco's engineers are continuously engaged in a research effort to extend the dimensions of the Power Supply art. Their work is regularly published and reprints are available to interested Power Supply users.

3. KEPCO POWER SUPPLY NEWS

A technical journal published bi-monthly with articles and news stories reporting developments in the Power Supply field.

For a complimentary copy of the "Kepco Power Supply Handbook", reprints of technical papers, or a subscription to the Kepco Power Supply News, write:

Publications Manager, KEPCO, INC., Dept. 663
131-38 Sanford Ave., Flushing, N.Y. 11352

Copies of these Kepco publications are also available through Kepco's field representatives.



131-38 SANFORD AVENUE • FLUSHING, N.Y. 11352 • Phone: (212) IN 1-7000
TWX # 212-539-6623 • Cable Address: KEPCOPOWER, NEWYORK



kepco

TRANSISTORIZED
design group

- voltage/current regulation
- full range programming
- 10-turn voltage control
- laboratory or systems use
- versatile, compact design

0.05% REGULATION and STABILITY

MODEL	DC OUTPUT RANGE		RIPPLE RMS MV	OUTPUT IMPEDANCE OHMS MAX.			MAX. INPUT AMPS AT 125 V AC
	VOLTS	AMPS		0C to 100 CPS	100 CPS to 1 KC	1 KC to 100 KC + μ H	
ABC 2-1M	0-2	0-1	0.25	0.001	0.01	0.1 + 0.5	0.3
ABC 7.5-2M	0-7.5	0-2	0.25	0.002	0.01	0.05 + 0.5	0.5
ABC 10-0.75M	0-10	0-0.75	0.25	0.007	0.02	0.1 + 1	0.3
ABC 15-1M	0-15	0-1	0.25	0.008	0.01	0.05 + 0.5	0.5
ABC 18-0.5M	0-18	0-0.5	0.25	0.02	0.02	0.1 + 1	0.3
ABC 30-0.3M	0-30	0-0.3	0.25	0.05	0.02	0.1 + 1	0.3
ABC 40-0.5M	0-40	0-0.5	0.25	0.04	0.02	0.05 + 0.5	0.5
ABC 100-0.2M	0-100	0-0.2	0.25	0.25	0.05	0.05 + 1	0.5

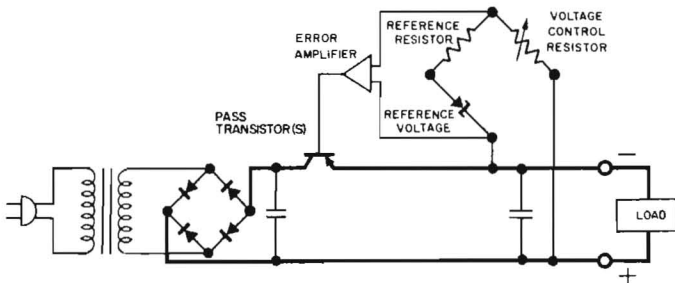

All models are designed for continuous operation without de-rating under all specified line, load and temperature conditions.

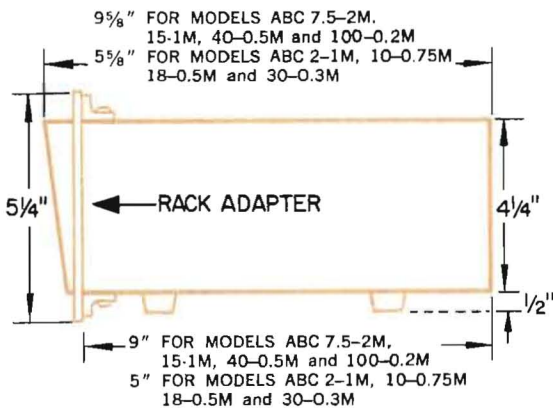

SPECIFICATIONS, Voltage Regulation Mode

REGULATION: Line: Less than 0.05% or 1 mv output voltage change, whichever is greater, for 105-125V AC or 210-250V AC line variation, at any output voltage within the specified range.

Load: Less than 0.05% or 1 mv output voltage change, whichever is greater for *no load* to *full load* change at any output voltage within the specified range.

STABILITY: Output voltage varies less than 0.05% or 3 mv, whichever is greater, over a period of 8 hours after warmup. Measured at constant line voltage, load and ambient temperature.

TEMPERATURE COEFFICIENT: Output voltage changes less than 0.05% per °C.

RIPPLE: Less than 0.25 mv rms.

RECOVERY TIME: 50 microseconds.

OUTPUT IMPEDANCE: Specified for each model within the load frequency range shown in the table. Above 10 kc include the reactive impedance of the effective series inductance as indicated.

SPECIFICATIONS, Current Regulation Mode

External Sensing

OUTPUT RANGE: Current regulation from 1 ma to 100% of the maximum rated current.

COMPLIANCE: Voltage compliance range is zero to 100% of the maximum output voltage.

For any selected current value, the output voltage is automatically varied throughout the compliance range as required to regulate the output current through a variable load.

REGULATION: Line: For 105-125V AC or 210-250V AC line variations, output current changes less than 0.1% when the specified voltage sample is maintained across the external sensing resistor.

Load: For the maximum change in load resistance, within the rated compliance range, output current changes less than 0.5% when the specified voltage sample is maintained across the external sensing resistor.

The sensing resistor is chosen to produce a one volt drop at the maximum operating current. A separate control is used externally to provide high resolution current adjustability.

STABILITY: Output current varies less than 0.1% or 1 ma, whichever is greater, over a period of 8 hours after warmup. Measured at constant line voltage, load and ambient temperature.

TEMPERATURE COEFFICIENT: Output current changes less than 0.1% per °C.

RIPPLE: Less than 0.1% of maximum current, rms.

SPECIFICATIONS, General

INPUT REQUIREMENTS: 105-125 or 210-250V AC, 50-440 cps single phase.

AMBIENT OPERATING TEMPERATURE: -20°C to +50°C maximum.

STORAGE TEMPERATURE: -40°C to +85°C maximum.

Data subject to change without notice
PATENT NOTICE: Applicable Patent Nos.
will be supplied on request.



ISOLATION VOLTAGE: A maximum of 500 volts can be connected between the chassis and either output terminal.

SPECIFICATIONS, Performance

CONTROLS: Continuously adjustable 10-turn voltage control permits output settings from zero to the maximum voltage. Resolution: 0.05% of maximum output.

PROGRAMMING: Special terminals provide for remote resistive programming of voltage or current at 1000 ohms per volt. Programming terminals are also provided for programming by means of remotely located voltage or current signals.

CURRENT LIMIT CONTROL: A single turn control provides adjustable current limiting from 25% to 150% of rated full-load current.

SHORT CIRCUIT PROTECTION: Unique current limiting circuitry permits continuous operation into a short circuit without the aid of fuses, circuit breakers or relays. Output returns instantly to the operating voltage when the overload is removed.

REMOTE ERROR SENSING: Error sensing terminals enable specified voltage regulation to be maintained directly at the load by compensating for voltage drops up to 0.5 volts across each load supply lead.

SERIES/PARALLEL OPERATION: Current limiting capability permits series or parallel operation. In parallel, units operate automatically to share a load by means of the current limiting feature.

COOLING: Heat removal is by natural convection, without blowers.

OVERSHOOT: No output voltage overshoot from turn-on, turn-off or power failure for output settings above 25% of max. rated voltage. Below 25%, output overshoot is a function of load and is negligible for loads in excess of 10%.

SPECIFICATIONS, Physical

METERS: Model numbers in table include 2½" combination voltmeter, ammeter; 2% full scale accuracy. To specify an unmetred unit, delete the suffix "M" from the model no., e.g., ABC 40-0.5, for unit without meters.

ON FRONT PANEL: DC output and ground (5-way) terminals. 10-turn voltage control, short circuit current adjusting control, AC on-off switch, pilot light and fuse. Volt/amp meter and meter selector switch provided on metered units.

On Rear of Chassis: Barrier strip terminations are provided for DC output and ground connections, resistive or voltage programming, current regulator connections, and remote error sensing. Access is provided for the voltage calibration control. Output terminals are isolated from the chassis, either positive or negative terminal may be grounded.

DIMENSIONS: 4¼" H x 8½¾" W. See outline drawing for the depth dimensions of each model.

STANDARD FINISH: Panel etched aluminum — brushed and coated. Case, gray hammertone (special finishes to order).

RACK MOUNTING: Rack mounting adapters (5¼" high x 19" wide) available for single or dual rack mounting:

Model RA-5 for mounting single unit.

Model RA-4 for mounting two units side by side.

See Accessory Page 43 for outline dimensional drawings of rack adapters.

kepco
TRANSISTORIZED
design group

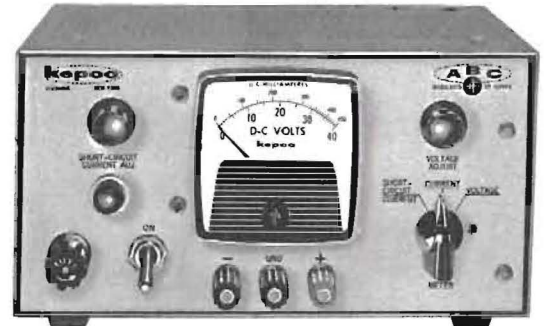

Model ABC 30-0.3M

ABC 40-0.5M

ABC 15-1M

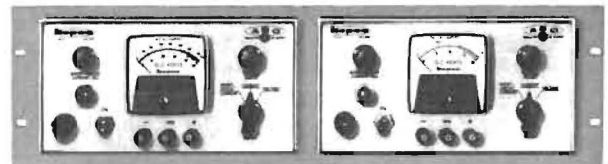

TYPICAL ASSEMBLY IN MODEL RA-4 RACK ADAPTER

ABC 7.5-2M

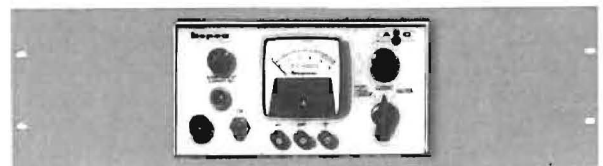

TYPICAL ASSEMBLY IN MODEL RA-5 RACK ADAPTER

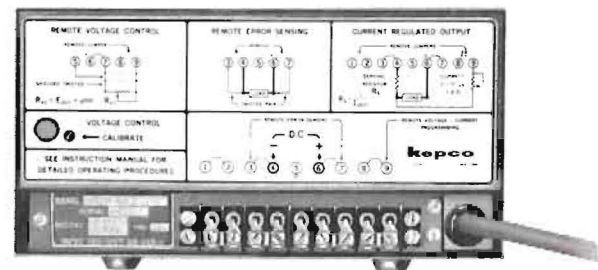

TYPICAL REAR VIEW SHOWING ACCESSIBLE TERMINAL BLOCK WITH SIMPLIFIED CONNECTION GUIDE.



kepco

HYBRID
design group

- voltage/current regulation
- full range programming
- 10-turn voltage control
- laboratory or systems use
- versatile, compact design

0.05% REGULATION and STABILITY

MODEL	DC OUTPUT RANGE		RIPPLE RMS MV	OUTPUT IMPEDANCE OHMS MAX.			MAX. INPUT AMPS At 125 V AC
	VOLTS	MA.		DC to 100 CPS	100 CPS to 1 KC	1 KC to 100 KC + μ H	
ABC 200M	0-200	0-100	0.5	1	0.5	2.0 + 2.0	0.5
ABC 425M	0-425	0-50	0.5	4	0.5	2.0 + 2.0	0.5
ABC 1000M	0-1000	0-20	1.0	25	1.0	2.0 + 10.0	0.5
ABC 1500M	0-1500	0-10	1.0	75	1.0	2.0 + 10.0	0.3
ABC 2500M	0-2500	0-2	1.0	625	1.0	2.0 + 10.0	0.3

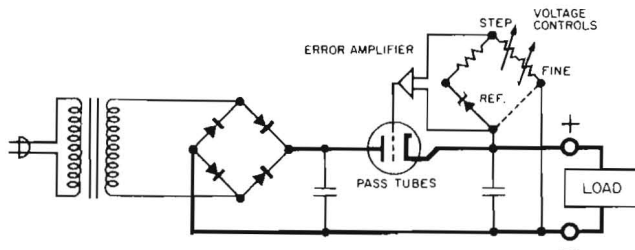

All models are designed for continuous operation without de-rating under all specified line, load and temperature conditions.

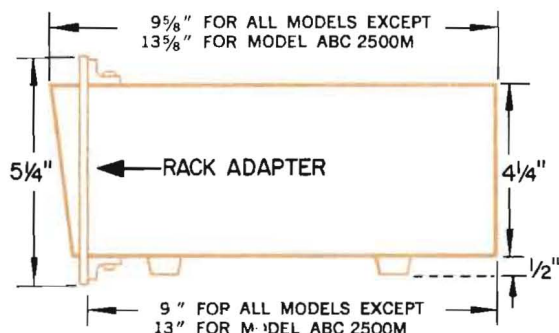

Data subject to change without notice

PATENT NOTICE: Applicable Patent Nos. will be supplied on request.

SPECIFICATIONS, Voltage Regulation Mode

REGULATION: *Line:* Less than 0.05% or 5 mv output voltage change, whichever is greater, for 105-125V AC or 210-250V AC line variation, at any output voltage within the specified range.

Load: Less than 0.05% or 5 mv output voltage change, whichever is greater, for *no load* to *full load* change at any output voltage within the specified range.

STABILITY: Output voltage varies less than 0.05% or 50 mv, whichever is greater, over a period of 8 hours after warmup. Measured at constant line voltage, load and ambient temperature.

TEMPERATURE COEFFICIENT: Output voltage changes less than 0.05% per °C.

RIPPLE: See table for maximum specification applicable to each model.

RECOVERY TIME: 50 microseconds.

OUTPUT IMPEDANCE: Specified for each model within the load frequency range shown in the table. Above 10 kc include the reactive impedance of the effective series inductance as indicated.

SPECIFICATIONS, Current Regulation Mode

External Sensing

OUTPUT RANGE: Current regulation from 1 ma to 100% of the maximum rated current.

COMPLIANCE: Voltage compliance range is zero to 100% of the maximum output voltage.

For any selected current value, the output voltage is automatically varied throughout the compliance range as required to regulate the output current through a variable load.

REGULATION: *Line:* For 105-125V AC or 210-250V AC line variations, output current changes less than 0.1% when the specified voltage sample is maintained across the external sensing resistor.

Load: For the maximum change in load resistance, within the rated compliance range, output current changes less than 0.1% when the specified voltage sample is maintained across the external sensing resistor.

The sensing resistor is chosen to produce a 10 volt drop at the maximum operating current. A separate control is used externally to provide high resolution current adjustability.

STABILITY: Output current varies less than 0.1% or 10 μ a, whichever is greater, over a period of 8 hours after warmup. Measured at constant line voltage, load and ambient temperature.

TEMPERATURE COEFFICIENT: Output current changes less than 0.1% per °C.

RIPPLE: Less than 0.1% of maximum current, rms.

SPECIFICATIONS, General

INPUT REQUIREMENTS: 105-125 or 210-250V AC, 50-440 cps single phase.

AMBIENT OPERATING TEMPERATURE: -20°C to +55°C maximum.

STORAGE TEMPERATURE: -40°C to +85°C maximum.

ISOLATION VOLTAGE: A maximum of 1000 volts can be connected between the chassis and either output terminal.

AUXILIARY OUTPUT: 6.5V AC, unregulated, at 2 amperes available at the rear terminals of Models ABC 200M and ABC 425M.

SPECIFICATIONS, Performance

CONTROLS: Continuously adjustable voltage control permits output settings from zero to the maximum voltage. The

voltage control on Models ABC 200M and ABC 425M is a single 10-turn control; resolution: 0.05% of maximum output. The voltage control for Models ABC 1000M, ABC 1500M and ABC 2500M consists of a 10-position step switch with a 10-turn control interpolating between switch positions; resolution: 0.005% of maximum output.

PROGRAMMING: Special terminals provide for remote resistance programming of voltage or current at 1000 ohms per volt. Programming terminals are also provided for external programming by means of remotely located voltage or current signals. Model ABC 2500M can only be programmed by remote voltage through its upper two-thirds output range. Consult factory for models modified for high speed slewing at up to 500,000 volts per second.

CURRENT LIMIT CONTROL: A single control provides adjustable current limiting from 25% to 150% of rated full-load current on Models ABC 200M and ABC 425M. Fixed current limiting, set to approximately 150% of rated maximum current is provided on Models ABC 1000M, ABC 1500M and ABC 2500M.

SHORT CIRCUIT PROTECTION: Unique current limiting circuitry permits continuous operation into a short circuit without the aid of fuses, circuit breakers or relays. Output returns instantly to the operating voltage when the overload is removed.

SERIES/PARALLEL OPERATION: Current limiting capability permits series or parallel operation. In parallel, units operate automatically to share a load by means of the current limiting feature. Series operation is limited to the 1000 volts of isolation.

HYBRID CIRCUIT: Unique design achieves high efficiency and reliability by using transistorized reference and amplification circuits for optimum regulation, stability and long life. Vacuum tubes are used for series pass elements for reliable high voltage operation.

COOLING: Heat removal is by natural convection.

OVERSHOOT: No output voltage overshoot from turn-on, turn-off or power failure for output settings above 25% of max. rated voltage. Below 25%, output overshoot is a function of load and is negligible for loads in excess of 10%.

SPECIFICATIONS, Physical

METERS: Model numbers in table include 2½" combination voltmeter, ammeter; 2% full scale accuracy. To specify an unmetred unit, delete the suffix "M" from the model no., e.g., ABC 200, for unit without meters. Models ABC 1000M, ABC 1500M and ABC 2500M include a voltmeter only.

TERMINALS AND CONTROLS: *On Front Panel:* DC output and ground (5-way) terminals. DC voltage control, AC on-off switch, pilot light and fuse. A volt/amp meter, meter selector switch and short circuit current adjusting control are provided on all models except ABC 1000M, ABC 1500M and ABC 2500M which contain a voltmeter only, plus the 10-position voltage step switch.

On Rear of Chassis: Barrier strip terminations are provided for DC output and ground connections, resistive or voltage programming and current regulator connections. Access is provided for the voltage calibration control. Output terminals are isolated from the chassis, either positive or negative terminal may be grounded.

DIMENSIONS: 4¼" H x 8½½" W. See outline drawing for the depth dimensions of each model.

STANDARD FINISH: Panel, etched aluminum — brushed and coated. Case, gray hammertone (special finishes to order).

RACK MOUNTING: Rack mounting adapters (5¼" high x 19" wide) available for single or dual rack mounting:

Model RA-5 for mounting single unit.

Model RA-4 for mounting two units by side.

See Accessory Page 43 for outline dimensional drawings.

kepco
HYBRID
design group

ABC
REGULATED DC SUPPLY

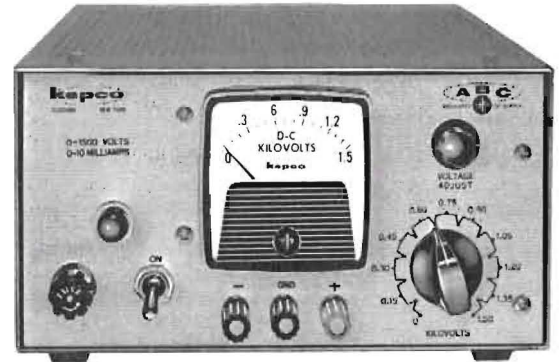

Model ABC 1500M

ABC 425M

ABC 1500M



TYPICAL ASSEMBLY IN MODEL RA-4 RACK ADAPTER

ABC 2500M



TYPICAL ASSEMBLY IN MODEL RA-5 RACK ADAPTER

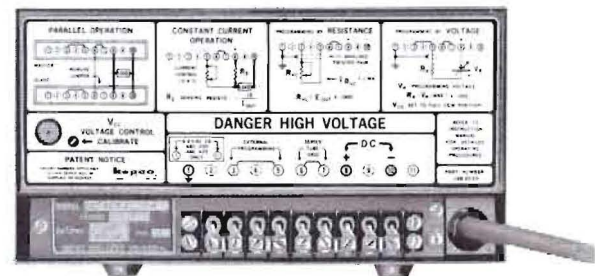

TYPICAL REAR VIEW SHOWING ACCESSIBLE TERMINAL BLOCK WITH SIMPLIFIED CONNECTION GUIDE.



kepco
TRANSISTORIZED
design group

- VIX[®] mode indicators
- automatic voltage/current crossover
- full range programming
- 10-turn voltage and current controls

REGULATION

0.005% LINE — 0.01% LOAD

MODEL	DC OUTPUT RANGE		OUTPUT IMPEDANCE OHMS MAX.			MAX. INPUT AMPS At 125 V AC
	VOLTS	AMPS	DC to 100 CPS	100 CPS to 1 KC	1 KC to 100 KC + μ H	
CK 2-8M	0-2	0-8	0.065×10^{-3}	0.01	0.05+0.5	1
CK 8-5M	0-8	0-5	0.16×10^{-3}	0.01	0.05+0.5	1.2
CK 18-3M	0-18	0-3	0.6×10^{-3}	0.01	0.05+0.5	1.3
CK 36-1.5M	0-36	0-1.5	2.4×10^{-3}	0.02	0.08+0.8	1.5
CK 40-0.8M	0-40	0-0.8	5×10^{-3}	0.02	0.08+0.8	1
CK 60-0.5M	0-60	0-0.5	12×10^{-3}	0.02	0.08+0.8	1

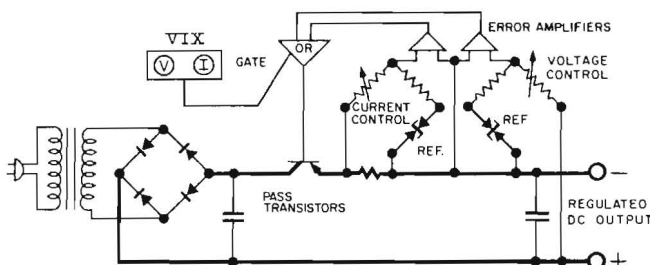
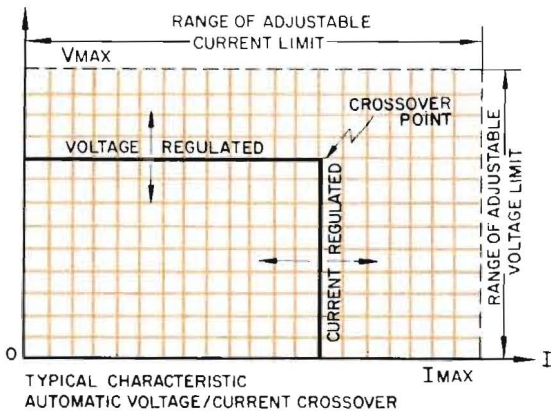

All models are designed for continuous operation without de-rating under all specified line, load and temperature conditions.

Data subject to change without notice. PATENT NOTICE: Applicable Patent Nos. will be supplied on request.

SPECIFICATIONS, Voltage Regulation Mode

REGULATION: *Line:* Less than 0.005% output voltage change for 105-125V/AC or 210-250V/AC line variation, at any output voltage within the specified range.

Load: Less than 0.01% or 0.5 mv output voltage change, whichever is greater for *no load to full load* change at any output voltage within the specified range. The 0.5 mv specification governs throughout the entire range of Model CK 2-8M.

STABILITY: Output voltage varies less than 0.01% or 2 mv, whichever is greater, over a period of 8 hours after warmup. Measured at constant line voltage, load and ambient temperature.

TEMPERATURE COEFFICIENT: Output voltage changes less than 0.01% per °C.

RIPPLE: Less than 0.5 mv rms.

RECOVERY TIME: 50 microseconds.

OUTPUT IMPEDANCE: Specified for each model within the load frequency range shown in the table. Above 10 kc include the reactive impedance of the effective series inductance as indicated.

SPECIFICATIONS, Current Regulation Mode

OUTPUT RANGE, Internal Sensing: Current regulation from less than 0.2% to 100% of the maximum specified current. Automatic crossover to voltage limiting provided.

External Sensing: Current regulation from 1 ma to 100% of the maximum rated current.

COMPLIANCE, Internal Sensing: Voltage compliance range is zero to the voltage control setting. The setting is adjustable, zero to 100% of the rated voltage range.

External Sensing: Voltage compliance range is zero to 100% of the maximum output voltage.

For any selected current value, the output voltage is automatically varied throughout the compliance range as required to regulate the output current through a variable load.

REGULATION, Internal Sensing: *Line:* Less than 0.01% or 0.2 ma, whichever is greater, output current change for 105-125V AC or 210-250V AC line variation at any output current within the specified range. For models rated at 2 amperes or less output current, the 0.2 ma regulation specification governs.

Load: Less than 0.01% or 0.2 ma, whichever is greater, output current change for the maximum change in load resistance within the rated compliance range. For models rated at 2 amperes or less output current, the 0.2 ma regulation specification governs.

REGULATION, External Sensing: *Line:* For 105-125V AC or 210-250V AC line variations, output current changes less than 0.01% when the specified voltage sample is maintained across the external sensing resistor.

Load: For the maximum change in load resistance, within the rated compliance range, output current changes less than 0.01% when the specified voltage sample is maintained across the external sensing resistor.

The sensing resistor is chosen to produce a one volt drop at the maximum operating current. A separate control is used externally to provide high resolution current adjustability.

STABILITY: Output current varies less than 0.05% or 1 ma, whichever is greater, over a period of 8 hours after warmup. Measured at constant line voltage, load and ambient temperature.

TEMPERATURE COEFFICIENT: Output current changes less than 0.05% (of maximum output current) per °C.

RIPPLE: Less than 0.05% of output current setting or 0.01% of maximum current rating, whichever is greater, rms.

SPECIFICATIONS, General

INPUT REQUIREMENTS: 105-125 or 210-250V AC, 50-65 cps single phase. Units available for 400 cps input on special order.

AMBIENT OPERATING TEMPERATURE: -20°C to +50°C max.

STORAGE TEMPERATURE: -40°C to +85°C maximum.

ISOLATION VOLTAGE: A maximum of 500 volts can be connected between the chassis and either output terminal.

SPECIFICATIONS, Performance

CONTROLS: Continuously adjustable 10-turn voltage and current controls permit output settings from zero to the maximum voltage and current. Resolution: 0.05% of maximum output.

PROGRAMMING: Special terminals provide for remote resistive programming of voltage or current at 1000 ohms per volt. Programming terminals are also provided for programming by means of remotely located voltage or current signals.

AUTOMATIC CROSSOVER: The automatic crossover circuit switches the operating mode of the power supply automatically from constant voltage to constant current or vice versa depending on the load relationship to the panel voltage and current adjustments. In the voltage regulation mode, the current control serves as a current limit adjustment while in current regulating mode, the voltage control serves as a voltage limiting adjustment.

VIX INDICATORS: The power supply's operating mode is indicated by a pair of front-panel signal lamps. One lamp is lighted during voltage regulated operation, the other during current regulated operation (internal current sensing only). Crossover from one mode to the other is signalled by the extinction of one lamp and the lighting of the other.

VIX REMOTE SIGNAL: A pair of rear-panel pin jacks, labelled "V" and "I" provide external access to the VIX signal. Pin V is 8 volts positive with respect to pin I during voltage regulated operation. Pin I is 8 volts positive with respect to Pin V during current regulated operation. Maximum loading: 10 K ohms; isolated from ground and the output terminals of the power supply. Crossover from one mode to the other is signalled by an abrupt polarity reversal.

REMOTE ERROR SENSING: Error sensing terminals enable specified voltage regulation to be maintained directly at the load by compensating for voltage drops up to 0.5 volts across each load supply lead.

SERIES/PARALLEL OPERATION: Automatic crossover capability permits series or parallel operation in either voltage or current regulating modes. Units operate automatically to share a load by means of their automatic crossover feature. Connections are also provided for operation in master/slave configuration.

COOLING: Lateral circulation by blowers insures efficient heat transfer; permits stacking of multiple units without overheating.

OVERSHOOT: No output voltage overshoot from turn-on, turn-off or power failure for output settings above 25% of max. rated voltage. Below 25%, output overshoot is a function of load and is negligible for loads in excess of 10%.

SPECIFICATIONS, Physical

METERS: Model numbers in table include 2½", rectangular voltmeter and ammeter; 2% full scale accuracy. To specify an unmetred unit, delete the suffix "M" from the model no. e.g., CK 18-3, for unit without meters.

TERMINALS AND CONTROLS: *On Front Panel:* AC on-off switch, fuse and two VIX mode lamps, 10-turn voltage control, 10-turn current control, DC output and ground (5-way) terminals.

On Rear of Chassis: Two VIX remote signal 0.08" pin jacks. Barrier strip connections for DC output and ground terminals, remote error sensing, voltage and current programming by remote resistance and/or voltage, master-slave parallel operation, external current sensing. Output terminals are isolated from the chassis, either positive or negative terminal may be grounded.

DIMENSIONS: 4¼"H x 8⅝"W x 13"D (behind rack adapter) 13⅝"D overall.

FINISH: Panel, etched aluminum — brushed and coated. Case, gray hammertone (special finishes to order).

MOUNTING: Rack mounting adapters (5¼" high x 19" wide) available for single or dual rack mounting:

Model RA 5 for mounting single unit.

Model RA 4 for mounting two units side by side.

See Accessory Page 43 for outline dimensional drawings of rack adapters.

kepco
TRANSISTORIZED
design group

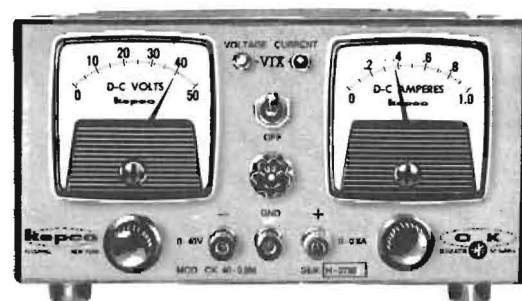

Model CK 40-0.8M

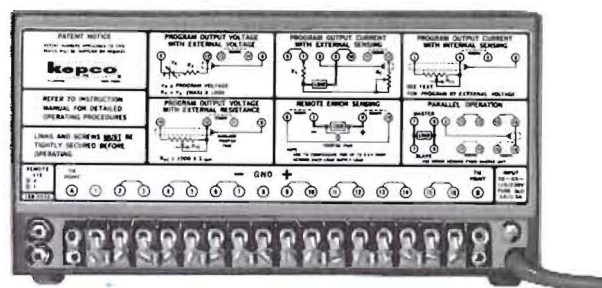

TYPICAL REAR VIEW SHOWING ACCESSIBLE TERMINAL BLOCK WITH SIMPLIFIED CONNECTION GUIDE

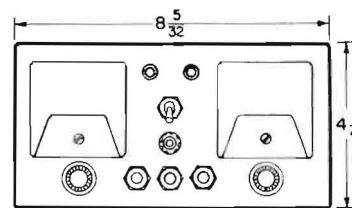

FRONT VIEW

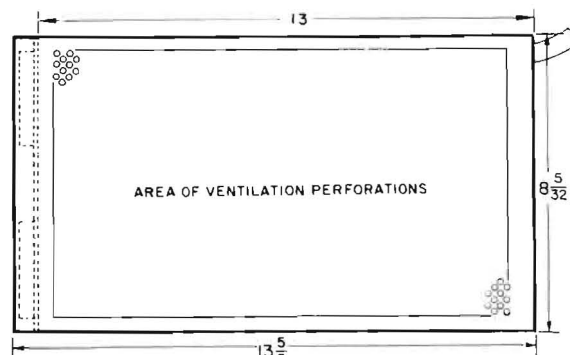

TOP VIEW

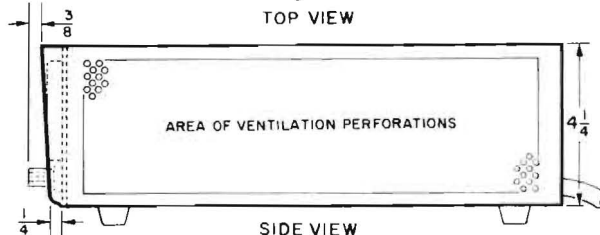

SIDE VIEW



kepco

HYBRID
design group

- unique hybrid regulator
- 10-turn vernier voltage control
- full range regulation
- full range programming
- voltage/current regulation

0.01% REGULATION and STABILITY

MODEL	DC OUTPUT RANGE		OUTPUT IMPEDANCE OHMS MAX.			AUX. OUTPUT 6.5VAC Unregulated	MAX. INPUT AMPS AT 125 V AC
	VOLTS	MA.	DC to 100 CPS	100 CPS to 1 KC	1 KC to 100 KC + μ H		
HB 2AM	0-325	0-200	0.2	0.08	0.2+0.5	EACH SUPPLY	2.0
HB 4AM	0-325	0-400	0.1	0.08	0.2+0.5		3.0
HB 6AM	0-325	0-600	0.06	0.08	0.2+0.5	HAS TWO 6 AMPERE OUTPUTS	5.0
HB 8AM	0-325	0-800	0.05	0.08	0.2+1.0		5.5
HB 250M	0-250	0-1000	0.025	0.08	0.2+0.5	OUTPUTS	8.0
HB 525M	0-525	0-500	0.1	0.08	0.2+0.5		8.0

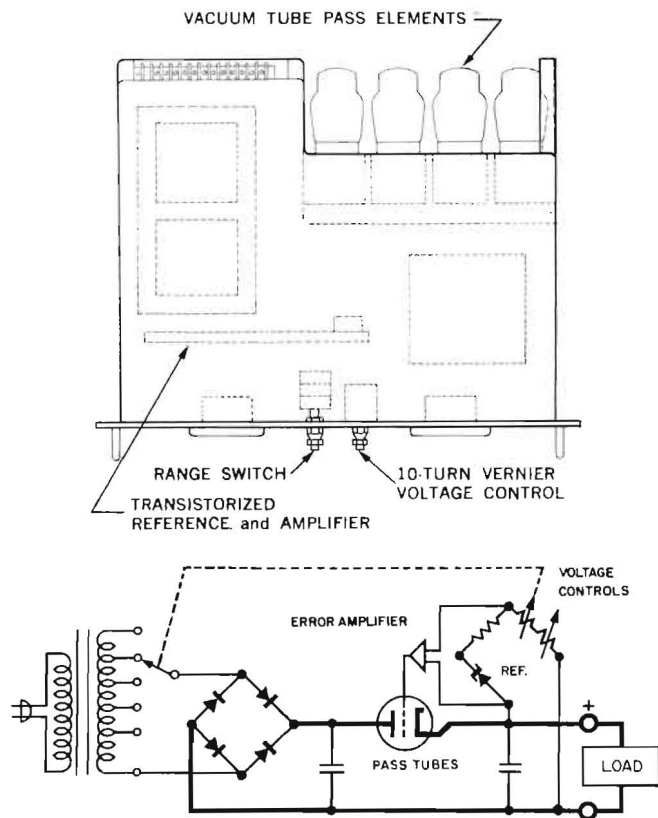

All models are designed for continuous operation without derating under all specified line, load and temperature conditions.

SPECIFICATIONS, Voltage Regulation Mode

REGULATION: Line: Less than 0.01% output voltage change for 105-125V AC or 210-250 V AC line variation, at any output voltage within the specified range.

Load: Less than 0.01% or 2 mv output voltage change, whichever is greater, for no load to full load change at any output voltage within the specified range.

STABILITY: Output voltage varies less than 0.01% or 2 mv, whichever is greater, over a period of 8 hours after warmup. Measured at constant line voltage, load and ambient temperature.

TEMPERATURE COEFFICIENT: Output voltage changes less than 0.01% per °C.

RIPPLE: Less than 1 millivolt, rms.

RECOVERY TIME: 50 microseconds.

OUTPUT IMPEDANCE: Specified for each model within the load frequency range shown in the table. Above 10 kc include the reactive impedance of the effective series inductance as indicated.

SPECIFICATIONS, Current Regulation Mode

External Sensing

OUTPUT RANGE: Current regulation from 10 ma to 100% of the maximum rated current.

COMPLIANCE: Voltage compliance equals the span of one band switch position anywhere in the range from zero to 100% of the maximum output voltage.

For any selected current value, the output voltage is automatically varied throughout the compliance range as required to regulate the output current through a variable load. The compliance voltage range can be increased to the full output voltage range when the output current is derated in accordance with the load current derating graph. The range switch sets the maximum voltage; should the load require an output voltage below the lower limit of the selected band, output current must be derated in accordance with the graph.

REGULATION: Line: For 105-125V AC or 210-250V AC line variations, output current changes less than 0.01% when the specified voltage sample is maintained across the external sensing resistor.

Load: For the maximum change in load resistance, within the rated compliance range, output current changes less than 0.01% when the specified voltage sample is maintained across the external sensing resistor.

The sensing resistor is chosen to produce a 10 volt drop at the maximum operating current. A separate control is used externally to provide high resolution current adjustability.

STABILITY: Output current varies less than 0.05% or 0.2 ma, whichever is greater, over a period of 8 hours after warmup. Measured at constant line voltage, load and ambient temperature.

TEMPERATURE COEFFICIENT: Output current changes less than 0.05% per °C.

RIPPLE: Less than 0.01% of maximum current, rms.

SPECIFICATIONS, General

INPUT REQUIREMENTS: 105-125 or 210-250V AC, 50-440 cps single phase.

Data subject to change without notice
PATENT NOTICE: Applicable Patent Nos.
will be supplied on request.



AMBIENT OPERATING TEMPERATURE: -20°C to $+55^{\circ}\text{C}$ maximum.

STORAGE TEMPERATURE: -40°C to $+85^{\circ}\text{C}$ maximum.

ISOLATION VOLTAGE: A maximum of 600 volts can be connected between the chassis and either output terminal.

AC OUTPUT: Two 6.5V AC outputs, unregulated at 6 amperes each. Series for 13V AC-CT., at 6 amperes; parallel for 6.5V AC at 12 amperes.

SPECIFICATIONS, Performance

VOLTAGE RANGE SWITCH: Provides step output settings in five discrete voltage bands. The range switch divides the output into five approximately equal segments.

FINE CONTROL: A 10-turn control interpolates between steps of the band switch. Resolution: 0.02% of maximum output voltage.

PROGRAMMING: Special terminals provide for remote resistive programming of voltage or current at 100 ohms per volt.

REMOTE ERROR SENSING: Model HB 250M and Model HB 525M include error sensing terminals to enable the specified voltage regulation to be maintained directly at the load by compensating for voltage drops up to 0.5 volts across each load supply lead.

HYBRID CIRCUIT: Unique design achieves high efficiency and reliability by using transistorized reference and amplification circuits for optimum regulation, stability and long life. Vacuum tubes are used for series pass elements for reliable high voltage operation.

COOLING: Heat removal is by natural convection. Pass tubes are physically remote from the sensitive comparison amplifier and are exposed at the rear for efficient heat transfer.

OVERSHOOT: No output voltage overshoot from turn-on, turn-off or power failure for output settings above 25% of max. rated voltage. Below 25%, output overshoot is a function of load and is negligible for loads in excess of 10%.

SPECIFICATIONS, Physical

METERS: Model numbers in table include $2\frac{1}{2}$ " rectangular voltmeter and ammeter; 2% full scale accuracy. To specify an unmetred unit, delete the suffix "M" from the model no., e.g., HB 2A, for unit without meters.

TERMINALS AND CONTROLS: *On Front Panel:* DC output and ground (5-way terminals), 5-position range switch and fine control (slotted shafts with locking devices), AC on-off switch, fuse and pilot light, DC on-off switch, fuse and pilot light.

On Rear of Chassis: Multi-terminal barrier strip contains DC output and ground, remote DC on-off, remote voltage control, program to zero and current regulator connections. Models HB 250M and HB 525M have remote error sensing terminals and provision for programming by means of remote voltage or current signals. All units have two 6.5V AC output terminals rated 6 amperes each. All output terminals are isolated from the chassis, either positive or negative output may be grounded.

DIMENSIONS: Standard EIA rack dimensions, $3\frac{1}{2}$ " H x 19" W x $14\frac{3}{8}$ " D (behind front panel).

STANDARD FINISH: Gray hammertone (special finishes to order).

kepco
HYBRID
design group

H B
REGULATED DC SUPPLY



Model HB 6AM

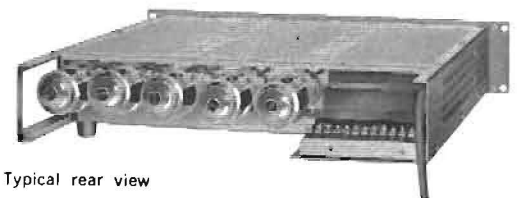

Typical rear view

LOAD CURRENT DERATING GRAPH

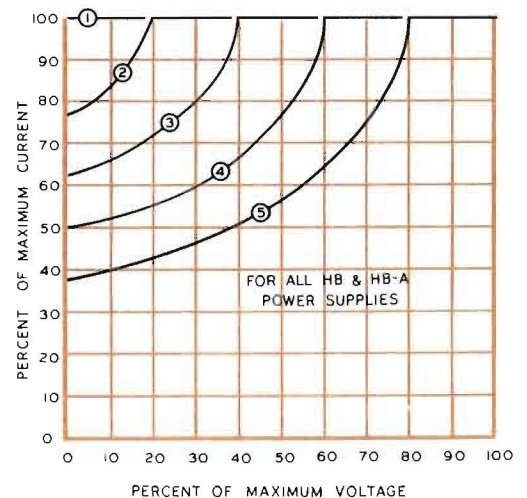

This graph is provided to help compute the over-ranging capabilities of HB Power Supplies when externally programmed outside of the normal range of the voltage band switch. The graph is particularly useful for determining the voltage compliance range of the power supplies in their constant current mode of operation. To use the graph, plot the desired current as a horizontal line; the intercept that this line makes with each numbered locus defines the minimum output voltage permissible for that particular range switch position. For example: with Model HB 4AM operating in current regulator mode at 60% of rated current, the voltage compliance limits are 30% to 80% when the voltage range switch is in position (4). This corresponds to operation at 240 ma in band position 4 with 160 volts of compliance between 100 V DC and 260 V DC.



MODULES

kepco
TRANSISTORIZED
design group

- isolated for transducer bridges
- plug-in mounting
- built-in 10-turn voltage control
- accessory case and cabinet for solitary or multiple installation

REGULATION
0.001% LINE — 0.005% LOAD

MODEL	DC OUTPUT RANGE		OUTPUT IMPEDANCE OHMS MAX.			MAX.* INPUT AMPS
	VOLTS	AMPS	DC to 100 cps	100 cps to 1 kc	1 kc to 100 kc+ μ h	
KG 25-0.2	0-25	0-0.2	0.006	0.01	0.1+1	0.2

*at 125V AC

The KG Power Supply has been especially optimized for unusual isolation of its DC terminals. This isolation is reflected in the lumped parameters for resistance and capacitance given in the specifications. Applications for *isolated* or *guarded* DC power range throughout the measurements field in which carefully balanced bridges are used to energize sensitive transducers (for example: strain/gauges). The exceptional regulation and excellent ripple performance of the KG Module fits it especially for this service.

The KG isolation derives from many factors, including a special power transformer, and careful layout of the mechanical components and circuit board foil patterns. To retain as much isolation as possible, equal care should be given to any wires connecting KG Modules with the AC mains, and its DC load. The DC wires especially should be placed for minimum coupling to ground.

KG isolation specifications are measured for, and apply only, when the panel voltage control is employed. Remote voltage control and/or current control inevitably increase the ground coupling.

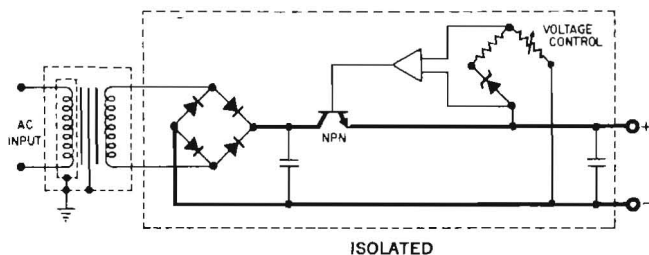

All models are designed for continuous operation without de-rating under all specified line, load and temperature conditions.

SPECIFICATIONS, Voltage Regulation Mode REGULATION:

Line: Less than 0.001% output voltage change for 105-125V AC line variation at any output voltage within the specified range.

Load: Less than 0.005% output voltage change, or 0.5 mv, whichever is greater, for no-load to full-load change, at any output voltage within the specified range.

STABILITY:

Output voltage varies less than 0.005% or 1 mv, whichever is greater, over a period of 8 hours after warmup. Measured at constant line voltage, load and ambient temperature.

TEMPERATURE COEFFICIENT:

Output voltage changes less than 0.005% per °C.

RIPPLE:

Less than 0.1 mv rms.

RECOVERY TIME:

50 microseconds.

OUTPUT IMPEDANCE:

Specified for the load frequency range shown in the table. Above 10 kc, include the reactive impedance of the effective series inductance, as indicated.

SPECIFICATIONS, Current Regulation Mode External Sensing:

OUTPUT RANGE:

Current Regulation from 1 ma to 100% of the maximum rated current.

COMPLIANCE:

Voltage compliance is zero to 100% of the maximum rated voltage. For any selected current value the output voltage is automatically varied throughout the compliance range, as required to regulated the output current through a variable load.

REGULATION:

Line: For 105-125V AC, output current changes less than 0.001% when the specified voltage is maintained across the external sensing resistor.

Load: For the maximum change in load resistance, within the rated compliance range, output current changes less than 0.01%, when the specified voltage sample is maintained across the external sensing resistor.

The sensing resistor is chosen to produce a 1 volt drop at the maximum operating current. A separate control is used externally to provide high resolution current adjustability.

STABILITY:

Output varies less than 0.01% over a period of 8 hours after warmup, measured at constant line voltage, load, and ambient temperature.

TEMPERATURE COEFFICIENT:

Output current changes less than 0.01% per °C.

SPECIFICATIONS, General INPUT REQUIREMENTS:

105-125V AC, 60 cps \pm 5%, single phase.

AMBIENT OPERATING TEMPERATURE:

-20°C to +50°C maximum.

STORAGE TEMPERATURE:

-40°C to +85°C maximum.

ISOLATION:

Output to Ground: Resistance: 10 kilomegohms minimum.
Capacitance: 200 picofarads maximum.
Voltage: 500 volts maximum.

Input to Output: Capacitance: 1 picofarad maximum.

SPECIFICATIONS, Performance

CONTROLS:

Continuously adjustable 10-turn voltage control with slotted shaft and lock permitting output settings from zero to the maximum voltage.

Resolution: 0.05% of maximum output.

PROGRAMMING:

Internal connections provide for remote voltage control (by resistance) at approximately 1000 ohms per volt. *Note:* Such connection may degrade ground isolation by the physical capacitance of the wires and remote control.

CURRENT LIMIT CONTROL:

A single-turn control, accessible through the front panel provides adjustable current limiting from 5% to 110% of rated full-load current.

SHORT CIRCUIT PROTECTION:

Sharp current limiting circuit permits continuous operation without the aid of fuses, circuit breakers or relays. Output returns automatically to the operating voltage when the overload is removed.

REMOTE ERROR SENSING:

Error sensing terminals enable specified voltage regulation to be maintained directly at the load by compensating for voltage drops up to 0.5 volts across each load supply lead.

SERIES/PARALLEL OPERATION:

Current limiting capabilities permit series or parallel operation. In parallel, units operate automatically to share a load by means of the current limiting feature.

COOLING:

Heat removal is by natural convection — no blowers.

OVERSHOOT:

No output voltage overshoot from turn-on, turn-off or power failure for output settings above 25% of the maximum rated voltage. Below 25% output, overshoot is a function of the load and is negligible for loads in excess of 10%.

SPECIFICATIONS, Physical

TERMINALS AND CONTROLS:

On Rear of Chassis: AC fuse-holder and printed circuit connector (containing (7) active terminals). Mates with Kepeco PC-1. Connector contains AC input, ground, DC output and error sensing terminals plus a blank which can be wired to the null junction in place of the internal voltage control for remote voltage or current programming.

On Front Panel: Screwdriver adjust voltage control (with lock), recessed current limit control, pilot light, handle and fasteners.

DIMENSIONS:

Panel: $2\frac{3}{16}$ " W x $5\frac{7}{32}$ " H x $\frac{1}{8}$ " thick; length of PC Card is $13\frac{19}{32}$ " from rear of front panel to the rear of the PC connector. $13\frac{29}{32}$ " to the rear of a protruding fuse. A handle protrudes 1" from the front surface of the panel.

Single unit case, Model CA-2: $2\frac{5}{64}$ " W x $5\frac{1}{32}$ " H x 14" L includes mounted Kepeco model PC-1 connector.

Multiunit housing, RA 19-8: Mounts (8) KG Power Supplies abreast in $5\frac{1}{4}$ " panel height; width standard 19"; depth 14". Includes (8) PC-1 connectors.

The uncased KG Power Supply has no mounting provisions. To use, it must be plugged into one of the above housings and a properly wired PC-1 connector.

STANDARD FINISH:

Light gray, color #26440, Fed. Std. 595, complies with Specification TT-E-529, Class B Semi-Gloss Enamel.

kepeco
TRANSISTORIZED
design group

K G
REGULATED DC SUPPLY
MODULES

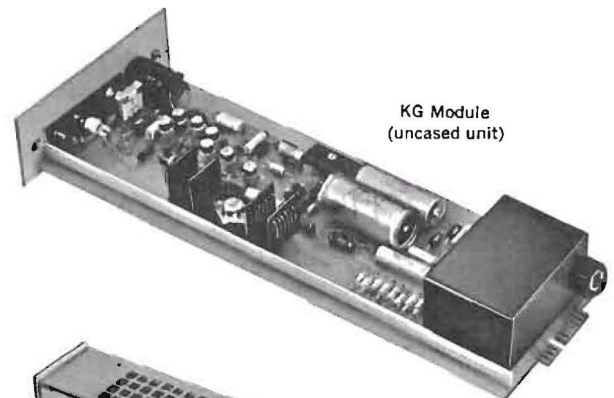

KG Module
(uncased unit)

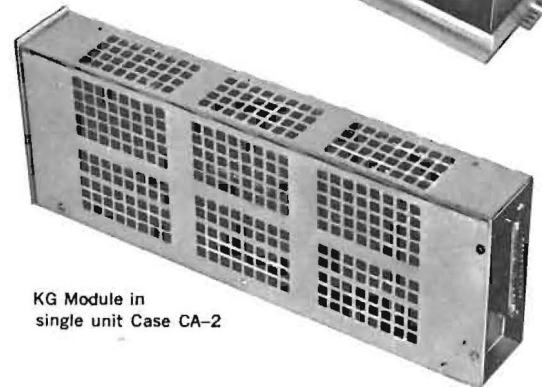

KG Module in
single unit Case CA-2



8 uncased KG Modules
in multiunit Housing RA 19-8

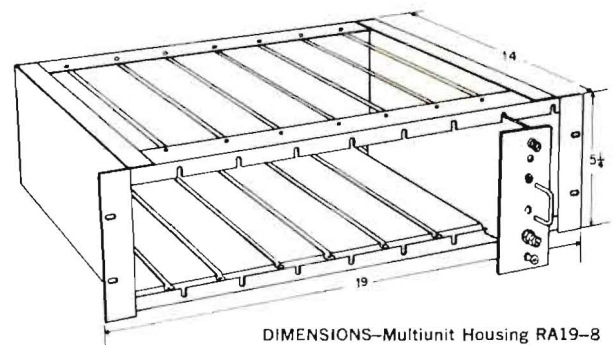

DIMENSIONS—Multiunit Housing RA19-8
Shipped disassembled
Assembly instructions included

Data subject to change without notice

PATENT NOTICE: Applicable Patent Nos. will be supplied on request



kepco

TRANSISTORIZED
design group

- automatic voltage/current crossover
- full range programming
- high current
- 10-turn voltage and current controls

1% REGULATION and STABILITY

MODEL	DC OUTPUT RANGE		RIPPLE RMS % MV	OUTPUT IMPEDANCE OHMS MAX.		MAX. INPUT At 125V AC	
	VOLTS	AMPS		1 KC to 10 KC	10 KC to 100 KC + μH	AMPS	WATTS
KO 12-100M	0-12	0-100	0.5 or 30	0.02	0.04 + 0.5	24	1800
KO 25-50M	0-25	0-50	0.5 or 40	0.02	0.04 + 0.5	24	1800
KO 45-30M	0-45	0-30	0.3 or 20	0.02	0.04 + 0.5	24	1800
KO 70-20M	0-70	0-20	0.3 or 30	0.02	0.04 + 0.5	24	1800

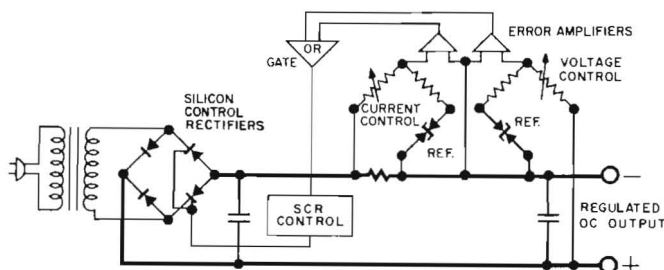
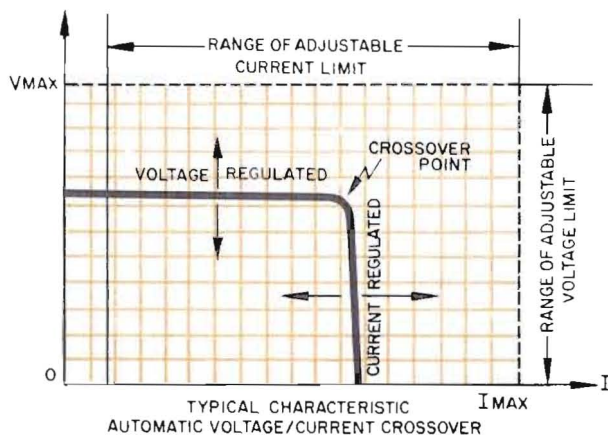

All models are designed for continuous operation without derating under all specified line, load and temperature conditions.

SPECIFICATIONS, Voltage Regulation Mode

REGULATION: Line: Less than 1% output voltage change for 105-125V AC or 210-250V AC line variation, at any output voltage within the specified range.

Load: Less than 1% or 20 mv output voltage change, whichever is greater, for no load to full load change at any output voltage within the specified range.

STABILITY: Output voltage varies less than 1% or 50 mv, whichever is greater, over a period of 8 hours after warmup. Measured at constant line voltage, load and ambient temperature.

TEMPERATURE COEFFICIENT: Output voltage changes less than 0.1% per °C.

RIPPLE: See table for maximum specification applicable to each model.

RECOVERY TIME: 500 milliseconds for 0-100% step load-on change or 100%-10% step load-off change.

OUTPUT IMPEDANCE: Specified for each model within the load frequency range shown in the table. Below 1000 cps, impedance is a function of load current and is determined by reference to the load regulation specification. Impedance is the slope $\Delta E/\Delta I$. Above 10 kc include the reactive impedance of the effective series inductance as indicated.

SPECIFICATIONS, Current Regulation Mode

Internal Sensing

OUTPUT RANGE: Current regulation from less than 10% to 100% of the maximum specified current. Automatic crossover to voltage limiting provided.

COMPLIANCE: Voltage compliance range is zero to the voltage control setting. The setting is adjustable, zero to 100% of the rated voltage range.

For any selected current value, the output voltage is automatically varied throughout the compliance range as required to regulate the output current through a variable load.

REGULATION: Line: Less than 2% or 200 ma, whichever is greater, output current change for 105-125V AC or 210-250V AC line variation at any output current within the specified range.

Load: Less than 2% or 200 ma, whichever is greater, output current change for the maximum change in load resistance within the rated compliance range.

STABILITY: Output current varies less than 2% or 200 ma, whichever is greater, over a period of 8 hours after warmup. Measured at constant line voltage, load and ambient temperature.

TEMPERATURE COEFFICIENT: Output current changes less than 0.5% (of maximum output current) per °C.

RIPPLE: Less than 0.5% of maximum current, rms.

SPECIFICATIONS, General

INPUT REQUIREMENTS: 105-125 or 210-250V AC, 50-65 cps, single phase. Input taps are also provided for operation from 104 ±9V AC and 208 ±18V AC.

Data subject to change without notice
PATENT NOTICE: Applicable Patent Nos.
will be supplied on request.



AMBIENT OPERATING TEMPERATURE: -20°C to $+50^{\circ}\text{C}$ maximum.

STORAGE TEMPERATURE: -40°C to $+85^{\circ}\text{C}$ maximum.

ISOLATION VOLTAGE: A maximum of 500 volts can be connected between the chassis and either output terminal.

SPECIFICATIONS, Performance

CONTROLS: Continuously adjustable 10-turn voltage and current controls permit output settings from zero to the maximum voltage and current. Resolution: 0.05% of maximum output.

PROGRAMMING: Special terminals provide for remote resistive programming of voltage or current at 100 ohms per volt. Programming terminals are also provided for programming by means of remotely located voltage or current signals.

AUTOMATIC CROSSOVER: The automatic crossover circuit switches the operating mode of the power supply automatically from constant voltage to constant current or vice versa depending on the load relationship to the panel voltage and current adjustments. In the voltage regulation mode, the current control serves as a current limit adjustment while in current regulating mode, the voltage control serves as a voltage limiting adjustment.

REMOTE ERROR SENSING: Error sensing terminals enable specified voltage regulation to be maintained directly at the load by compensating for voltage drops up to 0.5 volts across each load supply lead.

SERIES/PARALLEL OPERATION: Automatic crossover capability permits series or parallel operation in either voltage or current regulating modes. Units operate automatically to share a load by means of their automatic crossover feature. Connections are also provided for operation in master/slave configuration.

COOLING: Lateral circulation by blowers insures efficient heat transfer; permits stacking of multiple units without overheating.

SPECIFICATIONS, Physical

METERS: Model numbers in table include $2\frac{1}{2}$ " rectangular voltmeter and ammeter; 2% full scale accuracy. To specify an unmetereed unit, delete the suffix "M" from the model no., e.g., KO 70-20, for unit without meters.

TERMINALS AND CONTROLS: *On Front Panel:* AC on-off switch, circuit breaker/fuse and pilot light, 10-turn voltage control, 10-turn current control and reference circuit fuse. *On Rear of Chassis:* Barrier strip connections for: remote error sensing, voltage and current programming by remote resistance and/or voltage, master-slave parallel operation. DC output and ground terminals. Output terminals are isolated from the chassis, either positive or negative terminal may be grounded.

DIMENSIONS: Standard EIA rack dimensions, $8\frac{3}{4}$ " H x 19" W x 20" D. Side handles and bottom skids easily removable for rack mounting. Depth is measured behind front panel, see diagram.

FINISH: Gray hammertone (special finishes to order).

kepco
TRANSISTORIZED
design group



Model KO 45-30M

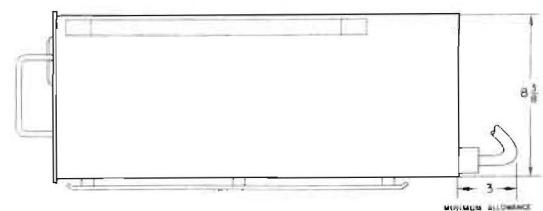
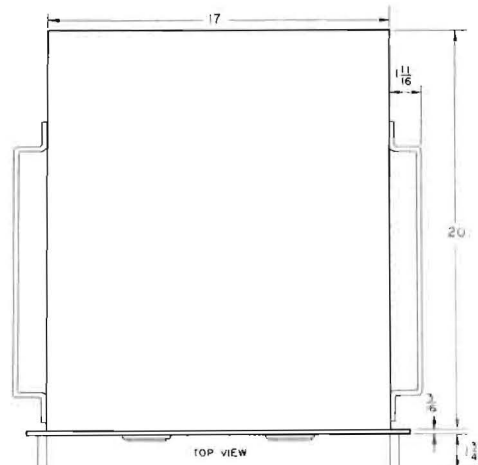
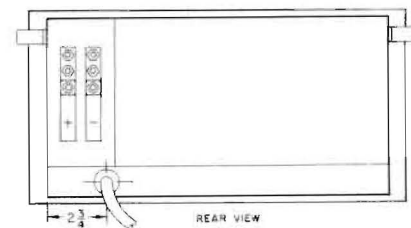
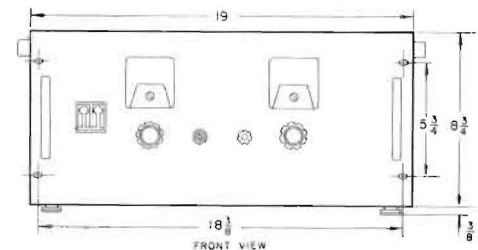



kepco

TRANSISTORIZED
design group

- VIX[®] mode indicators
- automatic voltage/current crossover
- full range programming
- 10-turn voltage and current controls

REGULATION 0.005% LINE - 0.01% LOAD

MODEL	DC OUTPUT RANGE		OUTPUT IMPEDANCE OHMS MAX.			SIZE	MAX. INPUT at 125V AC	
	VOLTS	AMPS	DC to 100 cps	100 cps to 1 kc	1 kc to 100 kc+ μ h		AMPS	WATTS
KS 8-15M	0-8	0-15	0.05×10^{-3}	0.01	0.04+0.4	A	4.4	320
KS 8-25M	0-8	0-25	0.03×10^{-3}	0.01	0.04+0.4	B	8.5	565
KS 8-50M	0-8	0-50	0.016×10^{-3}	0.005	0.02+0.4	C	15.5	1000
KS 8-100M	0-8	0-100	0.008×10^{-3}	0.005	0.02+0.4	D	32.0	2100
KS 18-10M	0-18	0-10	0.18×10^{-3}	0.01	0.04+0.5	A	6.7	345
KS 18-15M	0-18	0-15	0.12×10^{-3}	0.01	0.04+0.5	B	8.0	510
KS 18-25M	0-18	0-25	0.07×10^{-3}	0.005	0.04+0.5	C	14.0	900
KS 18-50M	0-18	0-50	0.035×10^{-3}	0.005	0.02+0.2	D	26.0	1800
KS 36-5M	0-36	0-5	0.7×10^{-3}	0.02	0.1 +1.0	A	4.8	290
KS 36-10M	0-36	0-10	0.4×10^{-3}	0.01	0.1 +1.0	B	8.9	580
KS 36-15M	0-36	0-15	0.25×10^{-3}	0.01	0.1 +0.6	C	12.2	860
KS 36-30M	0-36	0-30	0.1×10^{-3}	0.005	0.04+0.4	D	25.0	1600
KS 60-2M	0-60	0-2	3×10^{-3}	0.02	0.1 +1.0	A	3.0	250
KS 60-5M	0-60	0-5	1×10^{-3}	0.02	0.1 +1.0	B	7.0	500
KS 60-10M	0-60	0-10	0.6×10^{-3}	0.01	0.1 +1.0	C	13.0	1000
KS 60-20M	0-60	0-20	0.3×10^{-3}	0.01	0.1 +0.8	D	24.0	1700
KS 120-1M	0-120	0-1	10×10^{-3}	0.02	0.1 +1.0	A	3.0	250
KS 120-2.5M	0-120	0-2.5	5×10^{-3}	0.02	0.1 +1.0	B	7.0	500
KS 120-5M	0-120	0-5	3×10^{-3}	0.01	0.1 +1.0	C	13.0	1000
KS 120-10M	0-120	0-10	1×10^{-3}	0.01	0.1 +1.0	D	24.0	1700

DIMENSIONS

SIZE	H"	W"	D"
A	3 ¹ / ₂	19	14 ³ / ₈
B	5 ¹ / ₄	19	16
C	7	19	16
D	8 ³ / ₄	19	20

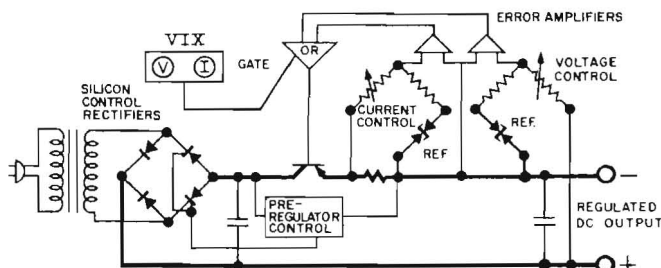

All models are designed for continuous operation without derating under all specified line, load and temperature conditions.

Data subject to change without notice

PATENT NOTICE: Applicable Patent Nos. will be supplied on request.

SPECIFICATIONS, Voltage Regulation Mode

REGULATION: *Line:* Less than 0.005% output voltage change for 105-125V/AC or 210-250V/AC line variation, at any output voltage within the specified range.

Load: Less than 0.01% or 0.5 mv output voltage change, whichever is greater, for no load to full load change at any output voltage within the specified range.

STABILITY: Output voltage varies less than 0.01% or 3 mv, whichever is greater, over a period of 8 hours after warmup. Measured at constant line voltage, load and ambient temperature.

TEMPERATURE COEFFICIENT: Output voltage changes less than 0.01% per °C.

RIPPLE: Less than 1 mv rms.

RECOVERY TIME: 50 microseconds.

OUTPUT IMPEDANCE: Specified for each model within the load frequency range shown in the table. Above 10 kc include the reactive impedance of the effective series inductance as indicated.

SPECIFICATIONS, Current Regulation Mode

OUTPUT RANGE, Internal Sensing: Current regulation from less than 0.5% to 100% of the maximum specified current. Automatic crossover to voltage limiting provided.

External Sensing: Current regulation from 10 ma to 100% of the maximum rated current.

COMPLIANCE, Internal Sensing: Voltage compliance range is zero to the voltage control setting. The setting is adjustable, zero to 100% of the rated voltage range.

External Sensing: Voltage compliance range is zero to 100% of the maximum output voltage.

For any selected current value, the output voltage is automatically varied throughout the compliance range as required to regulate the output current through a variable load.

REGULATION, Internal Sensing: *Line:* Less than 0.01% or 1 ma, whichever is greater, output current change for 105-125V AC or 210-250V AC line variation at any output current within the specified range. For models rated at 10 amperes or less output current, the 1 ma regulation specification governs.

Load: Less than 0.01% or 1 ma, whichever is greater, output current change for the maximum change in load resistance within the rated compliance range. For models rated at 10 amperes or less output current, the 1 ma regulation specification governs.

REGULATION, External Sensing: *Line:* For 105-125V AC or 210-250V AC line variations, output current changes less than 0.01% when the specified voltage sample is maintained across the external sensing resistor.

Load: For the maximum change in load resistance, within the rated compliance range, output current changes less than 0.01% when the specified voltage sample is maintained across the external sensing resistor.

The sensing resistor is chosen to produce a one volt drop at the maximum operating current. A separate control is used externally to provide high resolution current adjustability.

STABILITY: Output current varies less than 0.05% or 5 ma, whichever is greater, over a period of 8 hours after warmup. Measured at constant line voltage, load and ambient temperature.

TEMPERATURE COEFFICIENT: Output current changes less than 0.05% (of maximum output current) per °C.

RIPPLE: Less than 0.1% of output current setting or 0.05% of maximum current rating, whichever is greater, rms.

SPECIFICATIONS, General

INPUT REQUIREMENTS: 105-125 or 210-250V AC, 50-65 cps single phase.

AMBIENT OPERATING TEMPERATURE: -20°C to +50°C max.

STORAGE TEMPERATURE: -40°C to +85°C maximum.

ISOLATION VOLTAGE: A maximum of 500 volts can be connected between the chassis and either output terminal.

SPECIFICATIONS, Performance

CONTROLS: Continuously adjustable 10-turn voltage and current controls permit output settings from zero to the maximum voltage and current. Resolution: 0.05% of maximum output.

PROGRAMMING: Special terminals provide for remote resistive programming of voltage or current at 100 ohms per volt. Programming terminals are also provided for programming by means of remotely located voltage or current signals.

AUTOMATIC CROSSOVER: The automatic crossover circuit switches the operating mode of the power supply automatically from constant voltage to constant current or vice versa depending on the load relationship to the panel voltage and current adjustments. In the voltage regulation mode, the current control serves as a current limit adjustment while in current regulating mode, the voltage control serves as a voltage limiting adjustment.

VIX INDICATORS: The power supply's operating mode is indicated by a pair of front-panel signal lamps. One lamp is lighted during voltage regulated operation, the other during current regulated operation (internal current sensing only). Crossover from one mode to the other is signalled by the extinction of one lamp and the lighting of the other.

VIX REMOTE SIGNAL: A pair of rear-panel pin jacks, labelled "V" and "I" provide external access to the VIX signal. Pin V is 8 volts positive with respect to pin I during voltage regulated operation. Pin I is 8 volts positive with respect to pin V during current regulated operation. Maximum loading: 10K ohms; isolated from ground and the output terminals of the power supply. Crossover from one mode to the other is signalled by an abrupt polarity reversal.

REMOTE ERROR SENSING: Error sensing terminals enable specified voltage regulation to be maintained directly at the load by compensating for voltage drops up to 0.5 volts across each load supply lead.

SERIES/PARALLEL OPERATION: Automatic crossover capability permits series or parallel operation in either voltage or current regulating modes. Units operate automatically to share a load by means of their automatic crossover feature. Connections are also provided for operation in master/slave configuration.

COOLING: Lateral circulation by blowers insures efficient heat transfer; permits stacking of multiple units without overheating.

OVERSHOOT: No output voltage overshoot from turn-on, turn-off or power failure for output settings above 25% of max. rated voltage. Below 25%, output overshoot is a function of load and is negligible for loads in excess of 10%.

SPECIFICATIONS, Physical

METERS: Model numbers in table include 2½", rectangular voltmeter and ammeter; 2% full scale accuracy. To specify an unmetred unit, delete the suffix "M" from the model no., e.g., KS 8-100, for unit without meters.

TERMINALS AND CONTROLS: On Front Panel: AC on-off switch, circuit breaker/fuse and two VIX mode lamps. 10-turn voltage control, 10-turn current control, reference circuit fuse, DC output and ground terminals (8¾" models have output terminals on the rear only).

On Rear of Chassis: Two VIX remote signal 0.08" pin jacks. Barrier strip connections for: remote error sensing, voltage and current programming by remote resistance and/or voltage, master-slave, parallel operation, external current sensing. DC output and ground terminals. Output terminals are isolated from the chassis, either positive or negative terminal may be grounded.

DIMENSIONS: Standard EIA rack dimensions. Side handles and bottom skids easily removable for rack mounting (8¾" models). See table for dimensions of each model. Depth is measured behind front panel.

FINISH: Gray hammertone (special finishes to order).

kepco
TRANSISTORIZED
design group



Model KS 36-5M

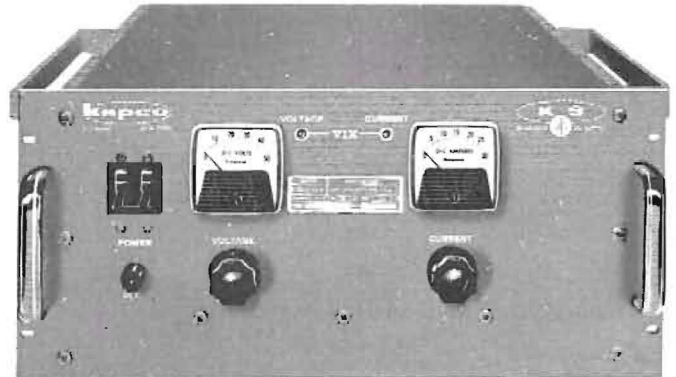

Model KS 36-30M



TYPICAL REAR VIEW SHOWING ACCESSIBLE TERMINAL BLOCKS WITH SIMPLIFIED CONNECTION GUIDE AND PROVISIONS FOR VIX REMOTE SIGNALING

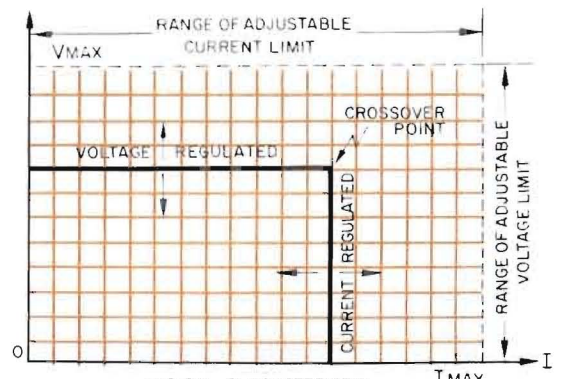

TYPICAL CHARACTERISTIC AUTOMATIC VOLTAGE/CURRENT CROSSOVER

- high gain dc amplifier
- provision for offset voltage and current nulling
- self-contained amplifier, power booster and power sources

OPERATIONAL POWER SUPPLY

MODEL	DC OUTPUT RANGE		OUTPUT IMPEDANCE		COMMON*
	VOLTS	AMPS	DC	SOURCE INDUCTANCE	
OPS-1	0-20	0-0.05	0.04	+15 μ h	Minus
OPS 7-2	0-7	0-2	0.0005	+15 μ h	Plus
OPS 15-1.5	0-15	0-1.5	0.001	+15 μ h	Plus
OPS 21-1	0-21	0-1	0.0025	+15 μ h	Plus
OPS 40-0.5	0-40	0-0.5	0.008	+15 μ h	Plus
OPS 72-0.3	0-72	0-0.3	0.025	+15 μ h	Plus
OPS 100-0.2	0-100	0-0.2	0.050	+15 μ h	Plus

*NOTE: Model OPS-1 employs PNP passing elements, hence its output is *Plus* with respect to a Minus common. The input is *Negative* with respect to the common. OPS 7-2 through OPS 100-0.2 employ NPN passing elements resulting in reversed polarities. Output is *Minus* with respect to the *Plus* common; the input is *Positive* with respect to the common.

PROGRAMMING SPEED

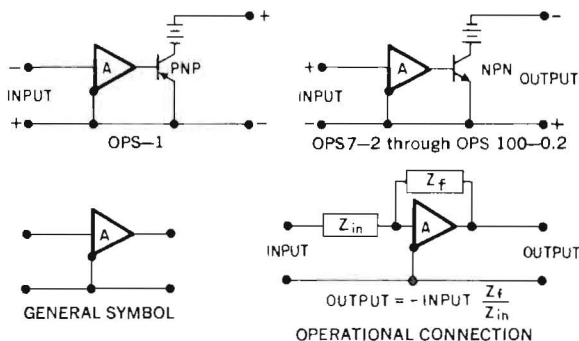
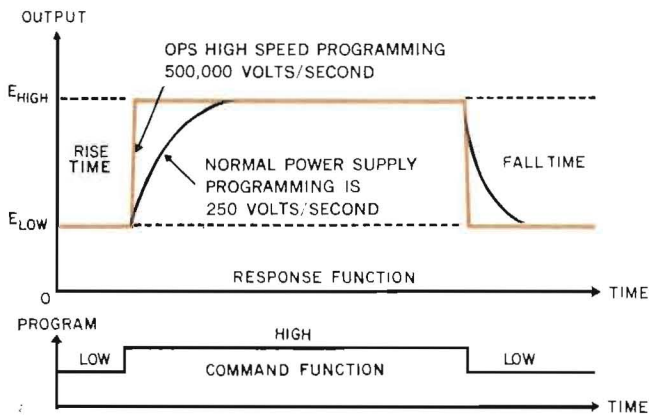

All models are designed for continuous operation without derating under all specified line, load and temperature conditions.

SPECIFICATIONS, Open Loop

OUTPUT: Volt-ampere ratings for the operational power supplies are given in the table of models. Outputs are unipolar (vary in one direction only) and are floating with respect to the chassis. All ratings are for continuous duty at maximum ambient temperatures.

CURRENT LIMITING: Adjustable from 10% to 110% of rated current. Fully protected for all short circuit conditions.

DC VOLTAGE GAIN: In excess of 80 db.

BANDWIDTH: 200 kc at unity gain crossing.
Rolloff slope: -6db per octave.

VOLTAGE SLEWING: 500,000 volts per second.

SINUSOIDAL FREQUENCY RESPONSE:

$$f_{max} = \frac{500,000}{\pi E_{pp}} \text{ cps} \approx \frac{160}{E_{pp}} \text{ ke.}$$

(E_{pp} is the peak-to-peak output voltage excursion.)

RIPPLE AND NOISE: Approximately 80 db below peak output or 3 mv rms, whichever is greater.

MAXIMUM CAPACITIVE LOADING: 0.001 μ f.

NOTE: Excess capacitance may result in peaking of the response, and possible instability. Adjustable lag networks are provided to compensate for a limited range of load reactance.

REGULATION AND STABILITY: All measurements are referred to the input junction. *Voltage* offset is multiplied by the *operational* gain. *Current* offset is multiplied by the *feedback* resistance to determine the effect upon the output.

Input changes are:

LINE: (105-125V AC)

LOAD: (no load to full load)

Offset Voltage: 100 μ V.

Offset Voltage: 1 mv.

Offset Current: 10 nA.

Offset Current: 10 nA.

STABILITY: Input changes measured over 8 hours at a constant line voltage, load, and ambient temperatures are:

Offset Voltage: 10 μ V per 8 hours.

Offset Current: 50 nA per 8 hours.

TEMPERATURE COEFFICIENT: Input changes measured as a result of temperature variations are:

Offset Voltage: 50 μ V per $^{\circ}$ C.

Offset Current: 50 nA per $^{\circ}$ C.

INPUT NULLING: A built-in trimmer provides for the nulling of the input offset voltage.

Resolution: approximately 1 millivolt.

A current source is provided to a trimming terminal to zero the input offset current.

Range: 0-12 microamperes controlled by external trimming resistance.

INTERNAL REFERENCE: A temperature compensated, 6.2V DC (nominal) zener regulated reference voltage is provided, together with a fixed input resistance, to deliver approximately 1 milliampere control current to the null junction. Terminals are provided to adjust the control current (increase the input resistance) from 0-1 ma. The internal reference can be used to generate a command for servoloop control, a bias for bipolar signals, or DC for voltage source or current source applications.

REFERENCE REGULATION: Less than 0.01% reference shift for 105-125V AC line variations.

STABILITY: Less than 0.01% reference shift over 8 hours at constant line voltage and ambient temperature.

Data subject to change without notice
PATENT NOTICE: Applicable Patent Nos.
will be supplied on request.

TEMPERATURE COEFFICIENT: Less than 0.01% change in reference per °C.

SPECIFICATIONS, General

INPUT: 105-125V AC or 210-250V AC 50-440 cps.

AMBIENT OPERATING TEMPERATURE: -20°C to +60°C.

STORAGE TEMPERATURE: -40°C to +85°C.

ISOLATION VOLTAGE: A maximum of 500 volts can be connected between the chassis and either output terminal.

SPECIFICATIONS, Performance

OPS 7-2 through OPS 100-0.2 are derivative of the Kepco PBX design group, sharing many of its characteristics and all of its hardware. Model OPS-1 is a special, low power amplifier available as OPS-1A in a bench style laboratory enclosure, with multiple panel terminations or as OPS-1C encased in a plug-in housing that matches the other operational power supplies, PAX/PBX, et al.

CONTROLS: OPS models include offset voltage trimmer, current limit control, two lag network controls and an adjustable feedback capacitance. Normally, input and feedback impedances are externally supplied to perform specific tasks except that a fixed input resistor (5700Ω) is provided for the DC reference source with provision for additional series resistances to adjust the control current.

REMOTE ERROR SENSING: Terminals are provided to connect the input part of the common bus, directly to a load, through a separate noncurrent carrying wire, thus maintaining a low DC source resistance *at the load terminals*.

Maximum drop: 0.5V DC.

COOLING: Heat removal is by natural convection; no blowers.

SPECIFICATIONS, Physical

TERMINALS AND CONTROLS: OPS-C models share the PAX-PBX mechanical configuration. All electrical access is via an 11-pin barrier strip and printed circuit connector containing AC input, ground, plus and minus output and error terminals, current offset nulling terminal, null junction, and control current adjustment access. The OPS-1A (bench model amplifier) has all active DC input/output terminals brought out as binding posts on the front panel. A null trim control (current offset screwdriver adjustment) is also located on the front panel. The voltage offset trimmer is adjustable through the rear.

DIMENSIONS: "C" style (uncased):
2 1/2" H x 3 3/16" x 12 3/16" D.

"C" style, cased (add suffix "C"):
2 1/16" H x 4 1/8" W x 13 3/16" D.

OPS-1 (uncased): 2 1/64" H x 4" W x 8" D.

OPS-1A (bench style): 4 1/8" H x 8 5/32" W x 5 5/8" D.
(Fits RA-4 and RA-5 Rack Adapters)

OPS-1C (plug-in case): 2 1/16" H x 4 1/8" W x 13 3/16" D.

See Accessory Pages 42-43 for details and dimensions of rack adapters and plug-in rack cabinets.

FINISH: "C" style: *Case and Chassis:* Blue anodized aluminum. *Panel Adapter:* Etched aluminum - brushed and coated.

OPS-1A: *Panel:* Etched aluminum - brushed and coated.
Case: Grey hammertone. (Special finishes to order).

kepco
TRANSISTORIZED
design group

OPS
OPERATIONAL AMPLIFIER
MODULES

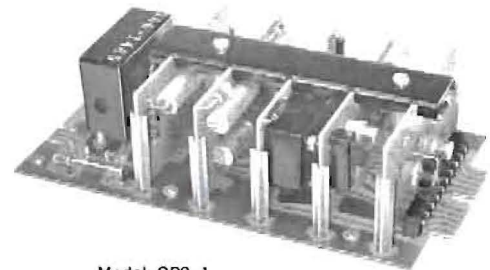

Model OPS-1
(uncased unit)

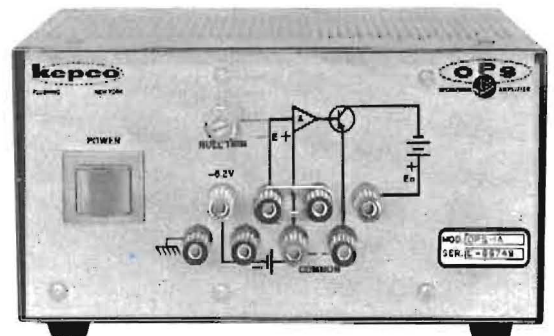

Model OPS-1A
(Bench style)

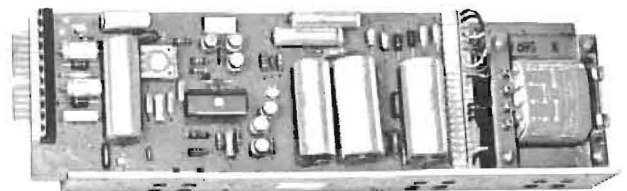

"C" Style (uncased)
for Models OPS 7-2 through
OPS 100-0.2 only



"C" Style (cased)
(Plug-in Housing)
Models OPS-1C and
OPS 7-2C through OPS 100-0.2C

- voltage/current regulation
- full range programming
- laboratory or systems use
- versatile, compact design
- high-speed models

0.05% REGULATION and STABILITY

MODEL	DC OUTPUT RANGE		OUTPUT IMPEDANCE OHMS MAX.			MAX. INPUT AMPS At 125 V AC
	VOLTS	AMPS	DC to 100 cps	100 cps to 1 kc	1 kc to 100 kc+ μ h	
PAX 7-1	0-7	0-1	0.004	0.02	0.1+1	0.3
PAX 7-1HS	0-7	0-1	0.004	0.2	0.2+15	0.3
PAX 15-0.75	0-15	0-0.75	0.010	0.02	0.1+1	0.3
PAX 15-0.75HS	0-15	0-0.75	0.010	0.2	0.2+15	0.3
PAX 21-0.5	0-21	0-0.5	0.025	0.02	0.1+1	0.3
PAX 21-0.5HS	0-21	0-0.5	0.025	0.2	0.2+15	0.3
PAX 36-0.3	0-36	0-0.3	0.06	0.02	0.1+1	0.3
PAX 36-0.3HS	0-36	0-0.3	0.06	0.2	0.2+15	0.3
PAX 72-0.15	0-72	0-0.15	0.025	0.02	0.1+1	0.3
PAX 72-0.15HS	0-72	0-0.1	0.025	0.2	0.2+15	0.3
PAX 100-0.1	0-100	0-0.1	0.5	0.02	0.1+1	0.3
PAX 100-0.1HS	0-100	0-0.15	0.5	0.2	0.2+15	0.3

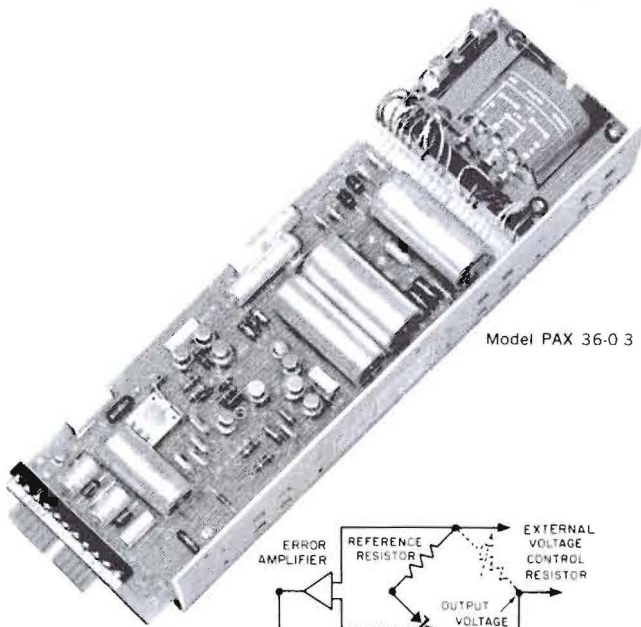

Model PAX 36-0.3

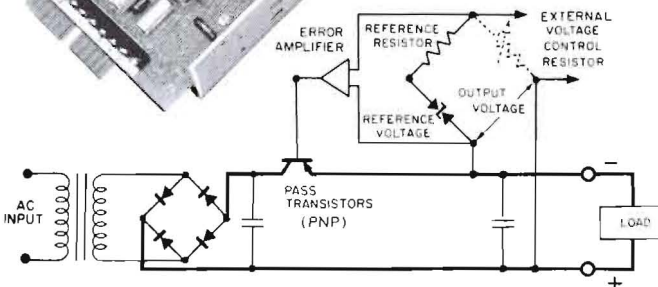

All models are designed for continuous operation without de-rating under all specified line, load and temperature conditions.

SPECIFICATIONS, Voltage Regulation Mode

REGULATION: Line: Less than 0.05% or 1 mv output voltage change, whichever is greater for 105-125V AC or 210-250V AC line variation, at any output voltage within the specified range.

Load: Less than 0.05% or 1 mv output voltage change, whichever is greater, for no load to full load change at any output voltage within the specified range.

STABILITY: Output voltage varies less than 0.05% or 3 mv, whichever is greater, over a period of 8 hours after warmup, measured at constant line voltage, load and ambient temperature. (see "Controls").

TEMPERATURE COEFFICIENT: Output voltage changes less than 0.05% per °C, (see "Controls").

RIPPLE: Standard: less than 0.25 mv rms.

High Speed: 60 db below peak output.

RECOVERY TIME: 50 microseconds.

OUTPUT IMPEDANCE: Specified for each model within the load frequency range shown in the table. Above 10 kc include the reactive impedance of the effective series inductance as indicated.

SPECIFICATIONS, Current Regulation Mode

External Sensing

OUTPUT RANGE: Current regulation from 1 ma to 100% of the maximum rated current.

COMPLIANCE: Voltage compliance range is zero to 100% of the maximum output voltage.

For any selected current value, the output voltage is automatically varied throughout the compliance range as required to regulate the output current through a variable load.

REGULATION: Line: For 105-125V AC or 210-250V AC line variations, output current changes less than 0.1% when the specified voltage sample is maintained across the external sensing resistor.

Load: For the maximum change in load resistance, within the rated compliance range, output current changes less than 0.1% when the specified voltage sample is maintained across the external sensing resistor.

The sensing resistor is chosen to produce a one volt drop at the maximum operating current. A separate control is used externally to provide high resolution current adjustability.

STABILITY: Output current varies less than 0.1% or 1 ma, whichever is greater, over a period of 8 hours after warmup. Measured at constant line voltage, load and ambient temperature.

TEMPERATURE COEFFICIENT: Output current changes less than 0.1% per °C.

RIPPLE: Less than 0.1% of maximum current rms.

SPECIFICATIONS, General

INPUT REQUIREMENTS: 105-125 or 210-250V AC, 50-440 cps single phase.

AMBIENT OPERATING TEMPERATURE: -20°C to +50°C maximum.

STORAGE TEMPERATURE: -40°C to +85°C maximum.

ISOLATION VOLTAGE: A maximum of 500 volts can be connected between the chassis and either output terminal.

SPECIFICATIONS, Performance

CONTROLS: PAX Modules are ordinarily supplied without controls. External fixed or variable programming resistors are used to control the output. Optionally, on special order, a built-in trimmer can be provided for up to 20 volts adjustment range. Stability and temperature coefficient criteria require the use of high quality LTC, 20 PPM wire wound elements for programming.

PROGRAMMING: Terminals provide for resistive program-

ming of voltage or current at approximately 1000 ohms per volt. Programming terminals are also provided for programming by means of remotely located voltage or current signals. Optionally, on special order, a built-in trimmer can be provided to adjust the control ratio over a 10% range so that exact value fixed programming resistances can be used. Add the suffix letter "R" to the model number to specify this option. Terminals are provided for external trimming.

HIGH SPEED MODELS: PAX Modules are provided with a choice of regulators for standard service or high speed operation. To designate a high speed PAX, add the suffix "HS" to the model number, e.g., PAX 21-0.5HS.

The HS regulator emphasizes the amplifier-like characteristics of the PAX Module, providing increased output circuit bandwidth by eliminating the capacitive output filtering.

High speed characteristics, operationally programmed:

Unity gain-bandwidth: 100 kc; slope: -6 db per octave

Maximum slewing rate: 50,000 volts per second

Open loop DC gain: in excess of 80 db

Sinusoidal frequency response: $f_{max} = \frac{50,000}{\pi E_{pp}} \text{ cps} \approx \frac{16}{E_{pp}} \text{ kc.}$

(E_{pp} is the peak to peak output voltage excursion.)

Maximum capacitive loading: 0.001 $\mu\text{f.}$

CURRENT LIMIT CONTROL: A single-turn control provides adjustable current limiting from 25% to 150% of rated full-load current.

SHORT CIRCUIT PROTECTION: Unique current limiting circuitry permits continuous operation into a short circuit without the aid of fuses, circuit breakers or relays. Output returns instantly to the operating voltage when the overload is removed.

REMOTE ERROR SENSING: Error sensing terminals enable specified voltage regulation to be maintained directly at the load by compensating for voltage drops up to 0.5 volts across each load supply lead.

SERIES/PARALLEL OPERATION: Current limiting capability permits series or parallel operation. In parallel, units operate automatically to share a load by means of the current limiting feature.

COOLING: Heat removal is by natural convection; no blower.

OVERSHOOT: No output voltage overshoot from turn-on, turn-off or power failure for output settings above 25% of maximum rated voltage. Below 25%, output overshoot is a function of load and is negligible for loads in excess of 10%.

SPECIFICATIONS, Physical

TERMINALS AND CONTROLS: *On Rear:* 11-terminal barrier strip and provision for accepting a 12-terminal printed circuit connector for AC input, DC output, error sensing and programming control functions. Output terminals are isolated from ground and either positive or negative output may be grounded.

DIMENSIONS: 2½" H x 3¼" W x 12¼" D. Uncased for chassis mounting.

Cased Unit: To specify cased unit, add suffix "C" to model no., e.g., PAX 36-0.3C for module with case.

Cased Dimensions: 2½" H x 4⅛" W x 13¼" D.

Various mounting accessories are available, including rack cabinets for plug-in mounting of four or six PAX Modules, and rack adapters mounting one, four or six units. See Accessory Page 42 for a detailed description, and dimensioned drawings of PAX accessories.

STANDARD FINISH: *Case and Chassis:* Blue anodized aluminum. *Panel Adapter:* Etched aluminum, brushed and coated (special finishes to order).

kepcO
TRANSISTORIZED
design group

PAX
REGULATED DC SUPPLY
MODULES

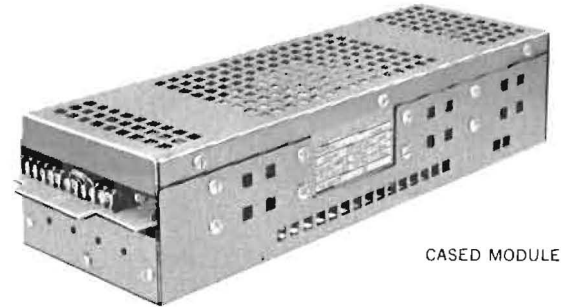

CASED MODULE



Rear view showing printed circuit board connector and keying pins



Cased unit with Panel Adapter RAP 6-1 (includes handle and fastener)



6 cased modules with Panel Adapters in Rack Cabinet RA 6-6

Data subject to change without notice
PATENT NOTICE: Applicable Patent Nos. will be supplied on request



kepco
TRANSISTORIZED
design group

- voltage/current regulation and programming
- all silicon design
- 71°C environment
- versatile, compact design

0.01% REGULATION and STABILITY

MODEL	DC OUTPUT RANGE		OUTPUT IMPEDANCE OHMS MAX.		
	VOLTS	AMPS	DC to 100 cps	100 cps to 1kc	1kc to 100kc
PBX 7-2	0-7	0-2	0.0005	0.02	0.1+1μh
PBX 15-1.5	0-15	0-1.5	0.001	0.02	0.1+1μh
PBX 21-1	0-21	0-1	0.0025	0.02	0.1+1μh
PBX 40-0.5	0-40	0-0.5	0.008	0.02	0.1+1μh
PBX 72-0.3	0-72	0-0.3	0.025	0.02	0.1+1μh
PBX 100-0.2	0-100	0-0.2	0.050	0.02	0.1+1μh

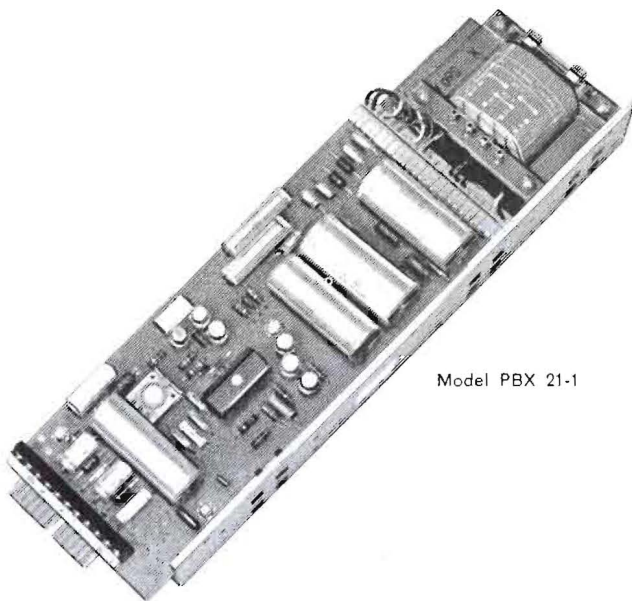

Model PBX 21-1

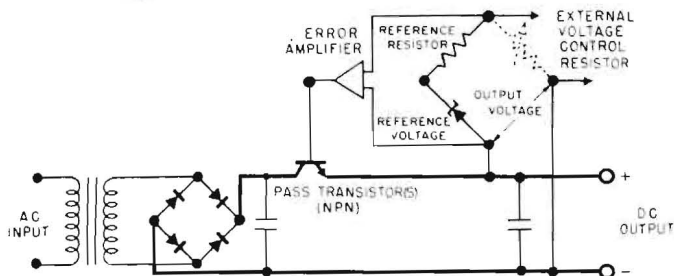

All models are designed for continuous operation without derating under all specified line, load and temperature conditions.

SPECIFICATIONS, Voltage Regulation Mode

REGULATION: *Line:* Less than 0.01% output voltage change for 105-125V AC or 210-250V AC line variation at any output voltage within the specified range.

Load: Less than 0.01% or 1 mv output voltage change, whichever is greater, for no load to full load change, at any output voltage within the specified range.

STABILITY: Output voltage varies less than 0.01% or 2 mv, whichever is greater, over a period of 8 hours after warmup. Measured at constant line voltage, load and ambient temperature. (See "Controls".)

TEMPERATURE COEFFICIENT: Output voltage changes less than 0.01 per °C. (See "Controls".)

RIPPLE: Less than 0.1 mv rms.

RECOVERY TIME: 50 microseconds.

OUTPUT IMPEDANCE: Specified for each model within the load-frequency range shown in the table. Above 10 kc include the reactive impedance of the effective series inductance, as indicated.

SPECIFICATIONS, Current Regulation Mode

External Sensing:

OUTPUT RANGE: Current regulation from 1 ma to 100% of the maximum rated current. For smaller current regulating circuits, refer to the Kepco Power Supply Handbook.

COMPLIANCE: Voltage compliance range is zero to 100% of the maximum voltage. For any selected current value, the output voltage is automatically varied throughout the compliance range as required to regulate the output current through a variable load.

REGULATION: *Line:* For 105-125V AC or 210-250V AC line variations, output current changes less than 0.01% when the specified voltage sample is maintained across the external sensing resistor.

Load: For the maximum change in load resistance, within the rated compliance range, output current changes less than 0.02% when the specified voltage sample is maintained across the external sensing resistor.

The sensing resistor is chosen to produce a one volt drop at the maximum operating current. A separate control is used externally to provide high resolution current adjustability.

STABILITY: Output current varies less than 0.05% or 1 ma, whichever is greater, over a period of 8 hours after warmup. Measured at constant line voltage, load and ambient temperature.

TEMPERATURE COEFFICIENT: Output current changes less than 0.05% per °C.

RIPPLE: Less than 0.02% of maximum current rms.

SPECIFICATIONS, General

INPUT REQUIREMENTS: 105-125V AC or 210-250V AC, 50-440 cps single phase.

AMBIENT OPERATING TEMPERATURE:

Cased: -20°C to +65°C.

Uncased: -20°C to +71°C.

STORAGE TEMPERATURE: -40°C to +85°C maximum.

SPECIFICATIONS, Performance

ISOLATION VOLTAGE: A maximum of 500 volts can be connected between the chassis and either output terminal.

CONTROLS: PBX Modules are ordinarily supplied without controls. External, fixed or variable programming resistors are used to control the output. Optionally, on special order, a

built-in trimmer can be provided for up to 20 volts adjustment range. Stability and temperature coefficient criteria require the use of high quality LTC, 20 PPM wire wound elements for programming.

PROGRAMMING: Terminals provide for resistive programming of voltage or current at approximately 1000 ohms per volt. Programming terminals are also provided for programming by means of remotely located voltage or current signals. The series pass control elements in PBX Modules are NPN, so that programming polarities are complementary to the usual PNP (all-transistor) models. Polarities are similar to hybrid supplies and employ the plus output terminal as the *common* point of the control bridge.

On special order, a built-in trimmer control can be provided to adjust the control ratio over a 10% range so that exact-value fixed programming resistances can be used. Add the suffix letter "R" to the model number to specify this option. Terminals are provided for external trimming.

HIGH SPEED OPERATION: For DC amplifier or idealized current regulation requiring high speed slewing, refer to OPS Design Group on Page 20.

CURRENT LIMIT CONTROL: A single-turn control provides adjustable current limiting from 10% to 105% of rated full-load current.

SHORT CIRCUIT PROTECTION: Unique current limiting circuitry permits continuous operation into a short circuit without the aid of fuses, circuit breakers or relays. Output returns instantly in the operating voltage when the overload is removed.

REMOTE ERROR SENSING: Error sensing terminals enable specified voltage regulation to be maintained directly at the load by compensating for voltage drops up to 0.5 volts across each load supply lead.

SERIES/PARALLEL OPERATION: Current limiting capability permits series or parallel operation. In parallel, units operate automatically to share a load by means of the current limiting feature.

COOLING: Heat removal is by natural convection; no blower.

OVERSHOOT: No output voltage overshoot from turn-on, turn-off or power failure for output settings above 25% of maximum rated voltage. Below 25%, output overshoot is a function of load and is negligible for loads in excess of 10%.

SPECIFICATIONS, Physical

TERMINALS AND CONTROLS: *On rear:* 11-terminal barrier strip and provision for accepting a 12-terminal printed circuit connector for AC input, DC output, error sensing and programming control functions. All terminals are arranged in the same relative positions as PAX Modules so that PBX can be interchanged with PAX in a RA 6-6 enclosure or other plug-in mounting arrangement.

Programming functions in the PBX are oppositely polarized with respect to PAX polarities, so that all functions are referred to the (+) terminal as common, rather than the (-) output terminal. Output terminals are isolated from ground and either positive or negative output may be grounded.

DIMENSIONS: 2½" H x 3¼" W x 12¼" D, *uncased* for chassis mounting.

Cased Unit: To specify cased unit, add suffix "C" to model number; e.g., PBX 21-1C for a module with case.

Cased Dimensions: 2½" H x 4¼" W x 13¼" D. PBX Models are physically interchangeable with PAX Modules, including rack adapters and plug-in rack cabinets, as described on Page 42.

STANDARD FINISH: *Case and Chassis:* Blue anodized aluminum. *Panel Adapter:* Etched aluminum, brushed and coated (special finishes to order).

kepco
TRANSISTORIZED
design group

PBX
REGULATED DC SUPPLY
MODULES

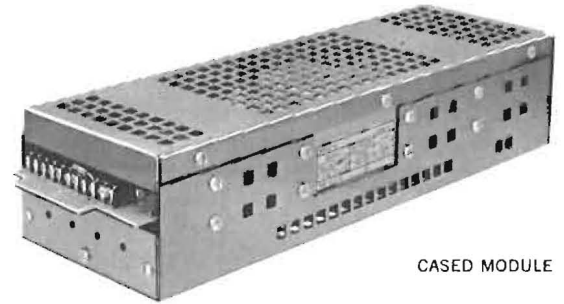

CASED MODULE

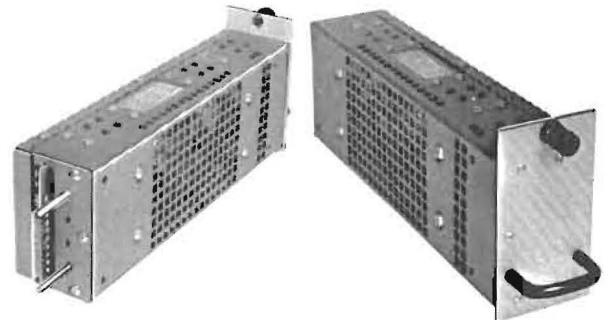

Rear view showing printed circuit board connector and keying pins

Cased unit with Panel Adapter RAP 6-1 (includes handle and fastener)



6 cased modules with Panel Adapters in Rack Cabinet RA 6-6

Data subject to change without notice
PATENT NOTICE: Applicable Patent Nos. will be supplied on request.

- constant voltage transformer regulator
- wide voltage range
- high current

SINGLE PHASE INPUT
±1% REGULATION LINE

MODEL	DC OUTPUT RANGE		RIPPLE RMS %	OUTPUT IMPEDANCE OHMS MAX.		DIMENSIONS			MAX. INPUT AMPS AT 125 V AC
	VOLTS	AMPS		1 KC to 10 KC	10 KC to 100 KC	H	W	D	
PR 15-10M	0-7.5-15	0-10	2	0.02	0.04 ± 0.1	3½"	19"	13¾"	3.5
PR 15-30M	0-15	0-30	2	0.02	0.04 ± 0.1	7"	19"	13¾"	7.0
PR 38-5M	0-19-38	0-5	1	0.03	0.04 ± 0.1	3½"	19"	13¾"	4.0
PR 38-15M	0-38	0-15	1	0.03	0.04 ± 0.2	7"	19"	13¾"	9.0
PR 80-2.5M	0-40-80	0-2.5	0.7	0.04	0.04 ± 0.1	3½"	19"	13¾"	3.5
PR 80-8M	0-80	0-8	0.7	0.05	0.07 ± 0.5	7"	19"	13¾"	9.5
PR 155-1M	0-78-155	0-1	0.6	0.1	0.1 ± 0.1	3½"	19"	13¾"	3.0
PR 155-4M	0-155	0-4	0.6	0.1	0.1 ± 0.5	7"	19"	13¾"	9.0
PR 220-3M	0-220	0-3	0.5	0.2	0.1 ± 0.5	7"	19"	13¾"	10.0
PR 310-0.6M	0-165-310	0-0.6	0.5	0.3	0.1 ± 0.1	3½"	19"	13¾"	3.0
PR 310-2M	0-310	0-2	0.5	0.3	0.1 ± 0.5	7"	19"	13¾"	9.0

FIGURE 1

3-PHASE INPUT
±2% REGULATION LINE

MODEL	DC OUTPUT RANGE		RIPPLE RMS %	OUTPUT IMPEDANCE OHMS MAX.		DIMENSIONS			MAX. INPUT AMPS AT 230 V AC
	VOLTS	AMPS		1 KC to 10 KC	10 KC to 100 KC	H	W	D	
PR 20-100AM	0-20	0-100	3	0.05	0.06 ± 0.1	8¾"	19"	20"	9.0
PR 40-50AM	0-40	0-50	2	0.05	0.06 ± 0.1	8¾"	19"	20"	8.5
PR 50-40AM	0-50	0-40	1.5	0.05	0.06 ± 0.1	8¾"	19"	20"	8.5

FIGURE 1

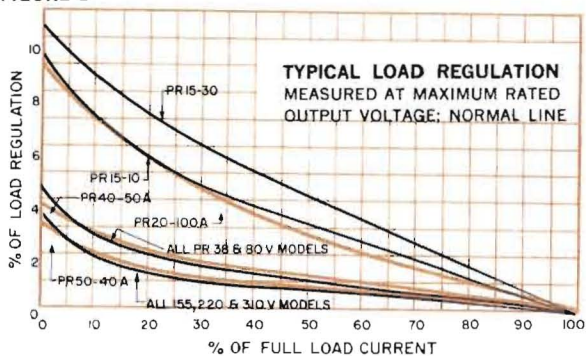
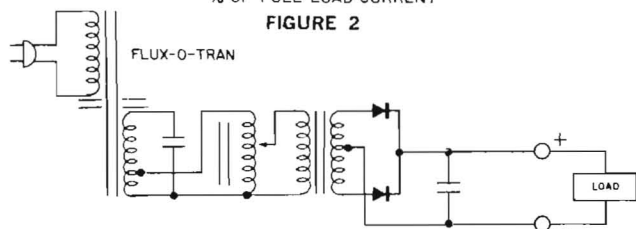

FIGURE 2



SPECIFICATIONS, General

REGULATION:

Line: Less than ±1% output voltage change for 115V ± 10V AC line variation at any output voltage within the load range specified in Figure 4. For models with 3-phase input, line regulation is ±2% for line variations of ±10%.

Load: -At maximum output voltage: Less than 2% output voltage change for HALF LOAD to FULL LOAD change (except 5% regulation for 15 and 20 volt models).

Less than 4% output voltage change for QUARTER LOAD to FULL LOAD change (except 8% regulation for 15 and 20 volt models). (See Figures 2 and 4.)

STABILITY:

Output varies less than 1% or 0.1V whichever is greater over a period of 8 hours after warmup. Measured at constant line voltage, load and ambient temperature.

RIPPLE:

For maximum % ripple at maximum rated output voltage and current, see Figure 1. For typical ripple values at reduced output currents see Figure 3. At lower output voltages the absolute value of the ripple is less than at maximum output voltage.

TEMPERATURE COEFFICIENT:

Output voltage changes less than 0.05% per °C.

AMBIENT OPERATING TEMPERATURE:

-20°C to +55°C maximum.

STORAGE TEMPERATURE:

-40°C to +85°C maximum.

OUTPUT IMPEDANCE:

Specified for each model within the load frequency range shown in the table. Below 1000 cps, impedance is a function of load current and is determined by reference to the load regulation curve. Impedance is the slope of the curve ΔE/ΔI. Above 10 kc include the reactive impedance of the effective series inductance as indicated.

INPUT REQUIREMENTS:

(For all 3½" and 7" high models): 115 ± 10V AC 60 cps ± 5% single phase.

(For all 8¾" high models): 208 or 230V AC ± 10%, 60 cps ± 5% three phase, 3-wire.

For models to operate at 104 ± 9V AC; 115 ± 10V AC; 208 ± 18V AC or 230 ± 20V AC, 50 cps ± 5%, add suffix "-50" to the model number and derate output voltage by 20%.

Suffix "-50", 3φ models will operate only with 208 or 230V AC ± 10%, 50 cps ± 5%.

Note: Percent changes in line frequency produce approximately equal percent changes in output voltage linearly within stated input frequency tolerances.

SPECIFICATIONS, Performance

CONTROLS:

Continuously variable voltage control permits output settings from 0.2% of maximum voltage to the maximum output voltage. Resolution ≈ 1% of maximum output voltage. On 3½" high models, the output is variable over two continuous ranges.

PARALLEL CONNECTION:

Units can be paralleled by adjusting the individual voltage controls to share the load.

CONSTANT VOLTAGE TRANSFORMER:

Flux-O-Tran power transformer delivers regulated square wave voltage to rectifiers, improving rectifier utilization and reducing output ripple.

OVERLOAD PROTECTION:

Special Flux-O-Tran power transformer and DC overload circuit breaker allows output to be shorted without adverse effect.

SILICON RECTIFIERS:

Reliable, efficient, full wave rectification.

CAPACITIVE FILTER:

No series choke, capacitive filtering provides excellent ripple reduction and minimizes transient response characteristics.

FORCED AIR COOLING:

Lateral circulation by blowers insures efficient heat transfer; permits stacking of units without overheating.

OVERSHOOT:

No output voltage overshoot from turn-on, turn-off or power failure for output settings above 25% of max. rated voltage. Below 25%, output overshoot is a function of load and is negligible for loads in excess of 10%.

ISOLATION VOLTAGE:

A maximum of 600 volts can be connected between the chassis and either output terminal.

SPECIFICATIONS, Physical

METERS:

Model numbers in table include 2½" voltmeter and ammeter; 2% full scale accuracy. To specify unmetred unit, delete the suffix "M" from the model number, eg, PR 155-4 for unit without meters.

TERMINALS AND CONTROLS:

On Front Panel: 3½" and 7" (single phase) units: DC output and ground (5-way) output terminals, voltage control, AC fuse, DC circuit breaker, pilot light. 7" units have conventional power on-off toggle switch, 3½" units have a combination on-off switch and 2 position range selector. 8¾" (3-phase) units: Combination on-off switch - circuit breaker, pilot light and voltage control.

On Rear of Chassis: DC output and ground terminals. All output terminals are isolated from the chassis, either positive or negative output may be grounded.

DIMENSIONS:

Standard EIA rack dimensions.

See table for specification of each model. Depth is measured behind front panel. On 8¾" models, side handles and bottom skids are easily removable for rack mounting. Heavy duty line cord is mounted at the rear, allow 3" minimum bend radius.

STANDARD FINISH:

Gray hammertone (special finishes to order).

kepco
SOLID STATE
design group



Model
PR 155-1M

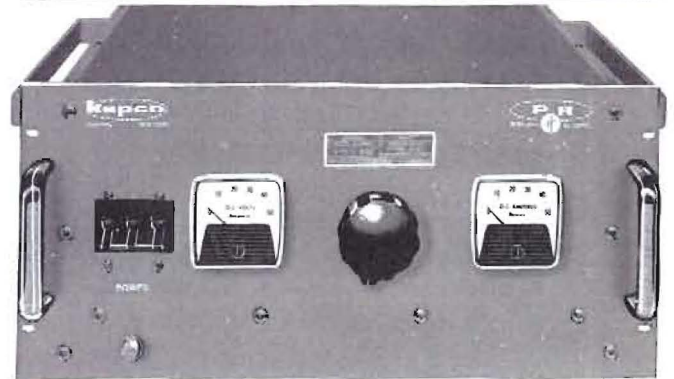

Model PR 40-50AM

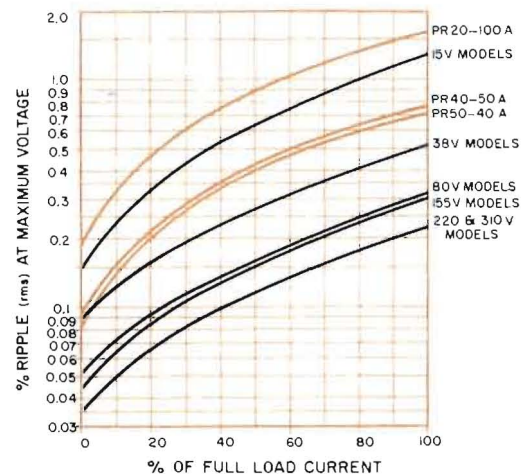

FIGURE 3 TYPICAL RIPPLE CHARACTERISTICS AS A FUNCTION OF LOAD CURRENT

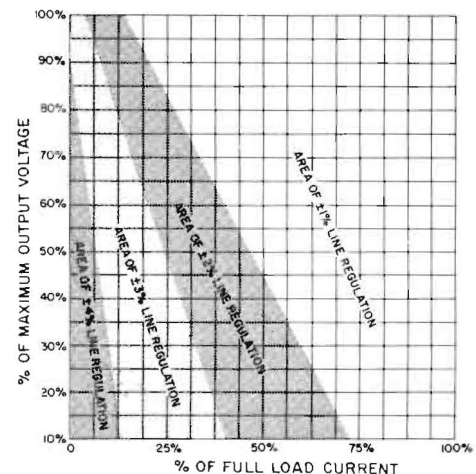

FIGURE 4 LINE REGULATION, 1-PHASE MODELS AS A FUNCTION OF OUTPUT VOLTAGE AND LOAD CURRENT



kepco
SOLID STATE
design group

*more DC output watts
per dollar, per pound,
per cubic inch*

*highly reliable, maintenance-
free operation assured by good
design and basic simplicity*

- fixed DC output voltages
- new extra filtered and dual output models

±1% REGULATION LINE

SIZE "A" - 180 SERIES

MODEL	DC OUTPUT		LOAD REGULATION* ΔV INCREASE		LOAD REG. CURVE (Fig. 1)	RIPPLE (MAX) RMS VOLTS
	VOLTS	AMPS	100%-50% LOAD	100%-25% LOAD		
PRM 6-25	6.3	0-25	0.4	0.6	1	0.4
PRM 12-15	12	0-15	0.4	0.8	1	0.4
PRM 18-10	18	0-10	0.5	0.9	2	0.3
PRM 24-8	24	0-8	0.5	0.9	2	0.3
PRM 28-7	28	0-7	0.5	0.9	2	0.4
PRM 36-5	36	0-5	0.8	1.3	3	0.4
PRM 48-4	48	0-4	1.0	1.8	4	0.3
PRM 60-3	60	0-3	1.0	1.8	5	0.3
PRM 120-1.5	120	0-1.5	2.2	3.6	7	0.3

*Measured at 115V AC Line.

PRM Modules are designed as basic fixed voltage DC sources for rack and chassis mounting. They feature an exceptionally wide input voltage tolerance and total isolation of line transients.

SIZE "B" - 120 SERIES

MODEL	DC OUTPUT		LOAD REGULATION* ΔV INCREASE		LOAD REG. CURVE (Fig. 1)	RIPPLE (MAX) RMS VOLTS
	VOLTS	AMPS	100%-50% LOAD	100%-25% LOAD		
PRM 6-15	6.3	0-15	0.5	0.7	1	0.4
PRM 12-10	12	0-10	0.6	1.0	2	0.4
PRM 18-6.7	18	0-6.7	0.8	1.3	3	0.3
PRM 24-5	24	0-5	1.0	1.7	3	0.3
PRM 28-4.3	28	0-4.3	1.2	2.0	4	0.3
PRM 36-3.3	36	0-3.3	1.5	2.4	5	0.3
PRM 48-2.5	48	0-2.5	1.8	3.1	6	0.3
PRM 60-2	60	0-2	2.3	3.8	7	0.3
PRM 120-1	120	0-1	4.3	7.3	9	0.3

*Measured at 115V AC Line.

Size "B" PRM modules are manufactured in the popular "low profile" package which permits up to 5 units to be racked together, providing as much as 600 watts in as little as 5 1/4" of panel space.

SPECIFICATIONS, General

REGULATION: *Line:* Less than ±1% output voltage for 115 ±15V AC line variation at loads greater than 25% of rating. Below 25% load, the output voltage change is less than ±1.5%.
Load: See Tables for maximum specification. See Figure 1 for typical load regulation curves.

INTERACTION: *Dual Output Models:* Loading one of the dual outputs, affects the voltage of the other by less than 2% as loading is changed from zero to maximum.

ACCURACY: ±2% of specified output voltage at nominal line, full load and 30°C ambient temperature. *For dual models,* voltage is measured with both outputs fully loaded.

ACCURACY: *Extra-Filtered Models:* The added choke of the extra-filtered section introduces a 2% drop in the nominal voltage rating at full load. A 10% reduction in output current is sufficient to restore the output to the nominal voltage.

Note: The initial (cold) output voltage of all power supplies is approximately 1% higher than the nominal value given in the table.

STABILITY: Output varies less than 1% or 0.1V, whichever is greater, over a period of 8 hours after warmup. Measured at constant line voltage, load and ambient temperature.

TEMPERATURE COEFFICIENT: Output voltage changes less than 0.05% per °C.

RIPPLE: For maximum ripple at maximum rated output voltage and current, see the tables. Typical ripple values at reduced output currents are given in Figure 2 for all models except *Extra Filtered*. Reduced ripple for *Extra Filtered Models* are graphed in Figure 3.

AMBIENT OPERATING TEMPERATURE: -20°C to +55°C maximum.

STORAGE TEMPERATURE: -40°C to +85°C maximum.

OUTPUT IMPEDANCE: Same for all models: 1 kc to 10 kc less than 0.05 ohms; 10 kc to 100 kc less than 0.05 ohms plus 0.5 μh effective series inductance. Below 1000 cps, impedance is a function of load current and is determined by reference to the load regulation curve. Impedance is the slope of the curve ΔE/ΔI.

INPUT REQUIREMENTS: 115V ±15V AC, 60 cps ±5%. Input current is approximately 3 amperes (280 watts) for the Series 180 and 180F modules; approximately 2 amperes (190 watts) for the 120 Series units; 5 amperes, 465 watts for the 300 Series modules. External fusing is required.

For models to operate at 104 ±13.5V AC; 115 ±15V AC; 208 ±27V AC or 230 ±30V AC, 50 cps, ±5%, add suffix "-50" to model number and derate output current by 20%. e.g.: PRM 24-5-50, operated from 50 cps ±5% line with 4 ampere output current rating.

Note: Percent changes in line frequency produce approximately equal percent changes in output voltage linearly within stated input frequency tolerances.

SPECIFICATIONS, Performance

CONSTANT VOLTAGE TRANSFORMER: Flux-O-Tran® power transformer delivers regulated square wave voltage to rectifiers, improving rectifier and capacitor utilization and reducing output ripple.

(Continued on Page 30)



Data subject to change without notice
PATENT NOTICE: Applicable Patent Nos.
will be supplied on request.

FIGURE 1:
TYPICAL LOAD
REGULATION
FOR ALL
PRM MODELS

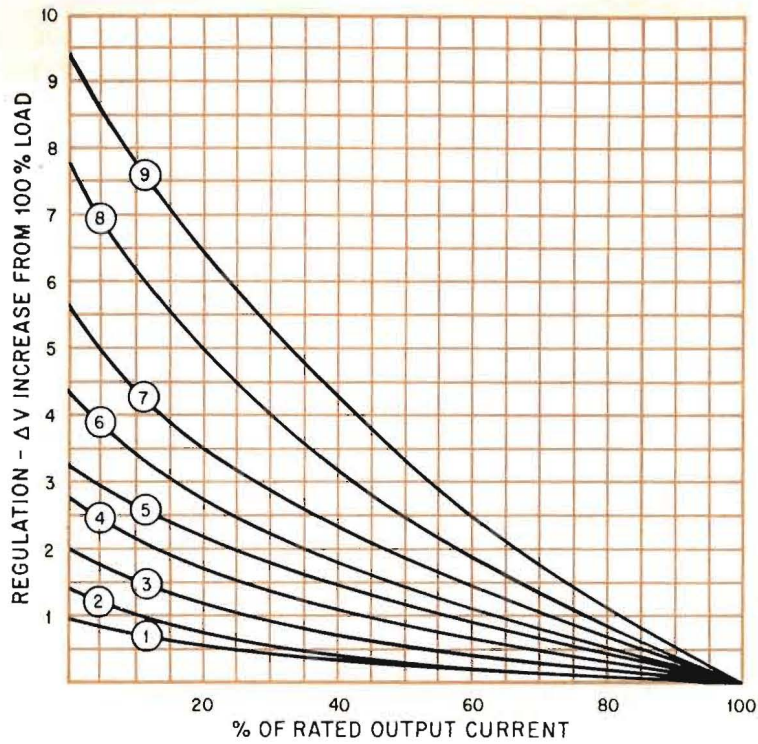

FIGURE 2:
TYPICAL RIPPLE
AS A FUNCTION
OF LOAD
FOR ALL PRM
MODELS EXCEPT
EXTRA FILTERED
MODELS

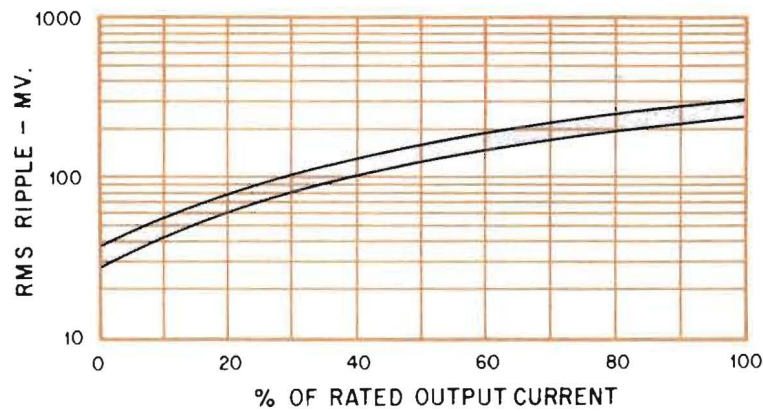
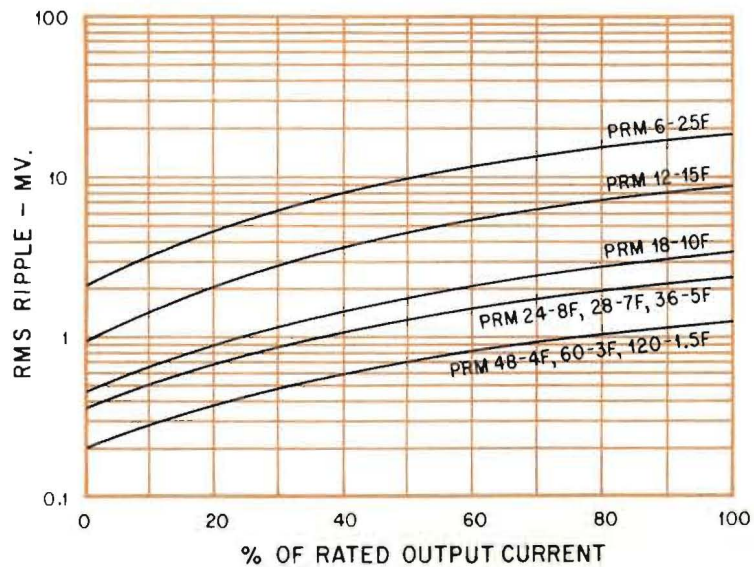

FIGURE 3:
TYPICAL RIPPLE
AS A FUNCTION
OF LOAD
FOR ALL
EXTRA FILTERED
MODELS



EXTRA-FILTERED MODELS
SIZE "C" - 180F SERIES

MODEL	DC OUTPUT**		LOAD REGULATION* ΔV INCREASE		LOAD REG. CURVE (Fig. 1)	RIPPLE (MAX) RMS VOLTS
	VOLTS	AMPS	100%-50% LOAD	100%-25% LOAD		
PRM 6-25F	6.3	0-25	0.6	1.0	1	0.04
PRM 12-15F	12	0-15	0.7	1.2	2	0.02
PRM 18-10F	18	0-10	0.8	1.4	3	0.01
PRM 24-8F	24	0-8	1.0	1.7	3	0.005
PRM 28-7F	28	0-7	1.1	1.8	3	0.005
PRM 36-5F	36	0-5	1.5	2.4	4	0.005
PRM 48-4F	48	0-4	1.7	2.9	5	0.003
PRM 60-3F	60	0-3	2.2	3.5	6	0.003
PRM 120-1.5F	120	0-1.5	3.8	6.8	8	0.003

*Measured at 115V AC Line.

**Less 2% filter drop (See ACCURACY)

Extra-filtered modules are designated by the use of the suffix symbol "F". An extra section LC network is added to reduce the AC ripple by better than 10:1 over a standard 180 series PRM Module (See Table.) They are packaged in the size "C" configuration.

DUAL OUTPUT MODELS
SIZE "C" - 300 SERIES

MODEL	DC OUTPUT		LOAD REGULATION ΔV INCREASE		LOAD REG. CURVE (Fig. 1)	RIPPLE (MAX) RMS VOLTS
	VOLTS	AMPS	100%-50% LOAD	100%-25% LOAD		
PRM 2X 4.5-20	4.5	0-20	0.5	0.7	1	0.3
	4.5	0-20				
PRM 2X 6-20	6.3	0-20	0.5	0.7	1	0.3
	6.3	0-20				
PRM 2X 12-12	12	0-12	0.6	1.0	2	0.3
	12	0-12				
PRM 2X 15-10	15	0-10	0.7	1.2	2	0.3
	15	0-10				
PRM 2X 18-8	18	0-8	0.8	1.3	2	0.3
	18	0-8				
PRM 2X 24-6	24	0-6	1.0	1.7	3	0.3
	24	0-6				
PRM 2X 28-5	28	0-5	1.2	2.0	4	0.3
	28	0-5				
PRM 2X 36-4	36	0-4	1.5	2.4	4	0.3
	36	0-4				
PRM 2X 48-3	48	0-3	1.8	2.9	5	0.3
	48	0-3				
PRM 2X 60-2.5	60	0-2.5	2.1	3.8	6	0.3
	60	0-2.5				

*Measured at 115V AC Line.

Dual PRM models contain two entirely independent outputs which may be used separately or together for up to 300 watts of useful output. Size C is an elongated "A" package and can be intermixed on either of the end mount rack adapters, RA 8-2 or RA 9-3.

All models are designed for continuous operation without derating under all specified line, load and temperature conditions.

OVERLOAD PROTECTION: Special Flux-O-Tran power transformer allows output to be shorted without adverse effect. A thermal overload circuit breaker is included in the *Dual Models* for back-up protection against short circuits when one output is unloaded, or lightly loaded.

CONVECTION COOLING: Heat removal is by natural convection.

ISOLATION VOLTAGE: A maximum of 600 volts can be connected between the chassis and either output terminal. A maximum of 600 volts can be connected between the outputs of *Dual Models*.

PARALLEL OPERATION: Supplies of the same model numbers can be paralleled for increased current. The two independent outputs of *Dual Models* may be parallel connected for approximately twice output current. (Total current should be derated by about 10% to allow for slight imbalance in current sharing).

SERIES OPERATION: Supplies can be series connected for increased voltage. The two independent outputs of *Dual Models* may be series connected for twice output voltage.

SPECIFICATIONS, Physical

TERMINALS AND CONTROLS: *On Rear of Chassis:* Barrier strip terminals provide for AC input, DC output and ground connections. Output terminals are isolated from ground and either positive or negative output may be grounded.

DIMENSIONS:

Size A: *Uncased:* 6 $\frac{3}{4}$ " H x 4 $\frac{3}{4}$ " W x 10 $\frac{3}{8}$ " D

Cased: 6 $1\frac{5}{16}$ " H x 5" W x 10 $\frac{7}{16}$ " D

Size B: *Cased only:* 3 $1\frac{3}{32}$ " H x 5" W x 13 $1\frac{3}{16}$ " D

Size C: *Uncased:* 6 $\frac{3}{4}$ " H x 4 $\frac{3}{4}$ " W x 14 $\frac{3}{8}$ " D

Cased: 6 $1\frac{5}{16}$ " H x 5" W x 14 $\frac{7}{16}$ " D

STANDARD FINISH: *Cases:* Blue finished aluminum, (special finishes to order). Size A and Size C chassis: cadmium plated, cronak wash.

ACCESSORIES: Size A and Size C units available with or without case. To specify cased unit add suffix "C" to the model number, e.g.: PRM 24-8C. Case includes wraparound, end plate and 4 removable feet for bench use.

RACK ADAPTERS: *For Size A:*

RA 8-2 (5 $\frac{1}{4}$ " H x 19" W) for (2) modules.

RA 9-3 (7" H x 19" W) for (3) modules.

RA 10-1 (5 $\frac{1}{4}$ " H x 19" W) for (1) module.

For Size B:

RA 14-3 (3 $\frac{1}{2}$ " H x 19" W) for (3) modules.

RA 15-1 (3 $\frac{1}{2}$ " H x 19" W) for (1) module.

RA 16-4 (5 $\frac{1}{4}$ " H x 19" W) for (4) modules.

RA 17-5 (5 $\frac{1}{4}$ " H x 19" W) for (5) modules.

For Size C:

RA 8-2 (5 $\frac{1}{4}$ " H x 19" W) for (2) modules.

RA 9-3 (7" H x 19" W) for (3) modules.

RA 18-1 (5 $\frac{1}{4}$ " H x 19" W) for (1) module.

See Accessory Page 43 for dimensional drawings.

STANDARD FINISH: Frosty etch, clear epoxy coating. (Special finishes to order.)

CUSTOM OPTIONS: Special models available with custom ratings. Contact your nearest Kepco sales engineer with your special requirements.

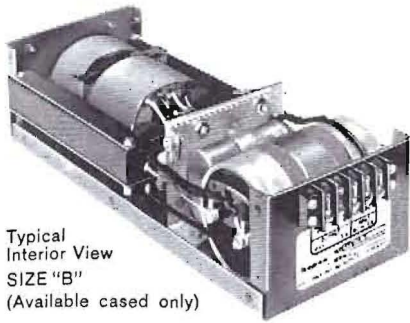

Typical Interior View
SIZE "B"
(Available cased only)

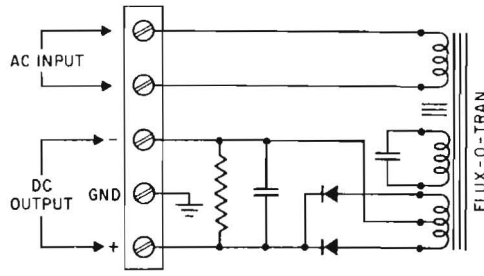

120 SERIES SCHEMATIC



SIZE "B"
(Bottom view)

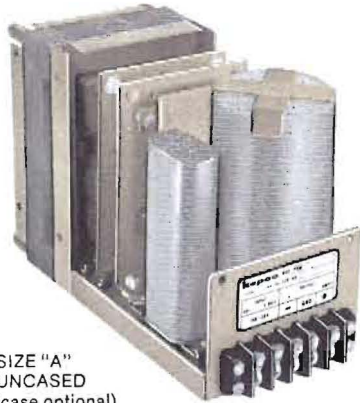

SIZE "A"
UNCASED
(case optional)

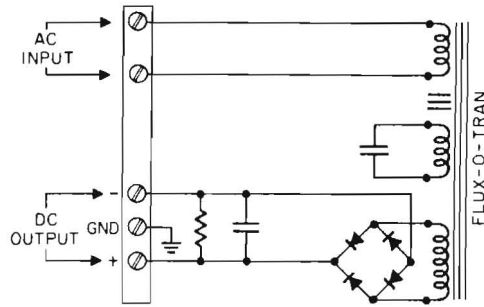

180 SERIES SCHEMATIC

NOTE: Low voltage models employ a center-tapped rectifier similar to the 120 series schematic.



SIZE "A"
CASED



SIZE "C"
UNCASED
(case optional)

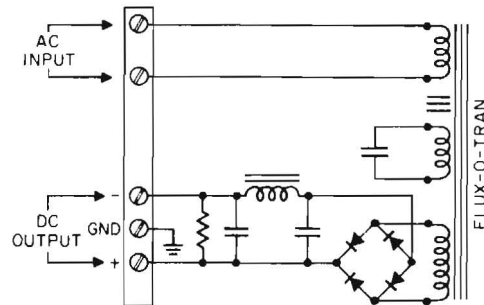

180F SERIES EXTRA FILTERED SCHEMATIC

NOTE: Low voltage models employ a center-tapped rectifier similar to the 120 series schematic.



SIZE "C"
CASED

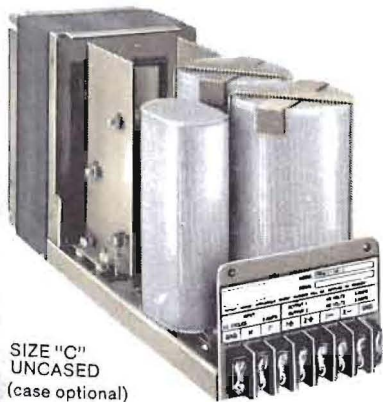

SIZE "C"
UNCASED
(case optional)

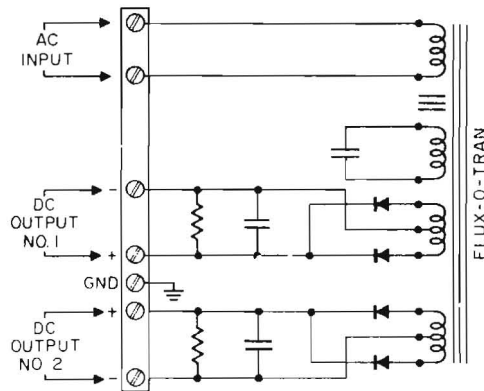

300 SERIES DUAL OUTPUT SCHEMATIC



SIZE "C"
CASED

- all silicon design
- modular packaging
- unique current cut-off protects load
- precision regulation
- full range programming

REGULATION
0.005% LINE — 0.05% LOAD

MODEL	DC OUTPUT RANGE		OUTPUT IMPEDANCE OHMS MAX.		
	VOLTS	AMPS	DC to 100 cps	100 cps to 1 kc	1 kc to 100 kc+ μ h
PWR 4-14	0-4	0-14	0.0002	0.005	0.1+0.5
PWR 7-11	0-7	0-11	0.0003	0.005	0.1+0.5
PWR 12-7	0-12	0-7	0.001	0.005	0.1+0.5
PWR 15-6	0-15	0-6	0.002	0.005	0.1+0.5
PWR 24-4	0-24	0-4	0.003	0.005	0.1+0.5
PWR 28-3.3	0-28	0-3.3	0.004	0.005	0.1+0.5
PWR 36-3	0-36	0-3	0.006	0.005	0.1+0.5
PWR 48-2	0-48	0-2	0.015	0.005	0.1+0.5
PWR 60-1.5	0-60	0-1.5	0.02	0.005	0.1+0.5

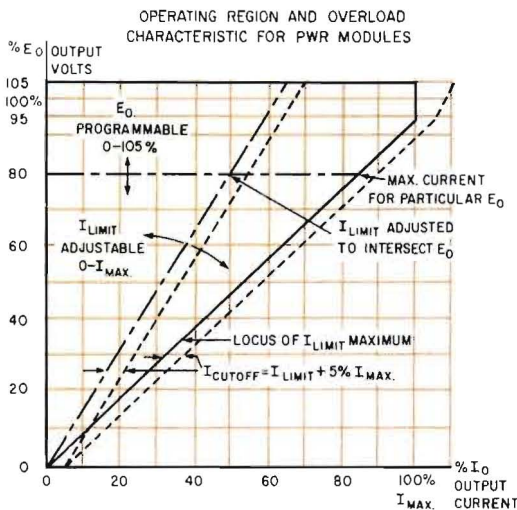

I_{LIMIT} IS THE MAXIMUM OPERATING CURRENT FOR ANY SELECTED CUTOFF CURRENT. I_{LIMIT} IS APPROXIMATELY EQUAL TO I_{CUTOFF} MINUS 5% I_{MAX} .

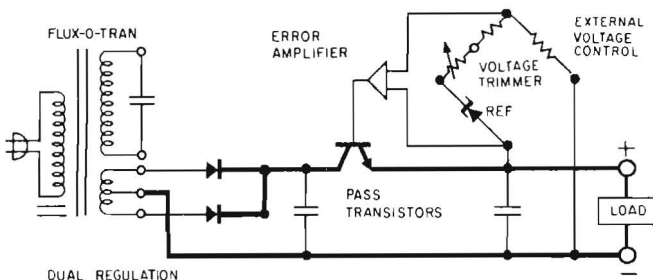

DUAL REGULATION

All models are designed for continuous operation without derating under all specified line, load and temperature conditions.

SPECIFICATIONS, Voltage Regulation Mode

REGULATION: Line: Less than 0.005% output voltage change for 100-130V AC variation.

Load: Less than 0.05% or 1 mv output voltage change, whichever is greater, for output current changes from no load to the current limit locus.

STABILITY: Output voltage varies less than 0.05% or 3 millivolts, whichever is greater, over a period of 8 hours after warmup. Measured at constant line voltage, load and ambient temperature. (See "Controls").

TEMPERATURE COEFFICIENT: Output voltage changes less than 0.05% per °C. (See "Controls").

RIPPLE: Less than 0.25 mv rms.

RECOVERY TIME: 50 microseconds.

OUTPUT IMPEDANCE: Specified for each model within the load frequency range shown in the table. Above 10 kc include the reactive impedance of the effective series inductance as indicated.

SPECIFICATIONS, Current Regulation Mode

External Sensing'

OUTPUT RANGE: Current regulation from 1 ma to 100% of the maximum rated current.

COMPLIANCE: Voltage compliance is from the intercept of the I_{LIMIT} locus to 105% of the rated maximum output voltage. For any selected current value, the compliance is the portion of the current line lying within the shaded portion of the operating region plot. The output voltage automatically varies throughout this region as required to regulate current through a variable load. For loads which require compliance outside of the operating region (below the limit locus), the current cut-off characteristic controls the output.

REGULATION: Line: For 100-130V AC line variations, output current changes less than 0.05% when the specified voltage sample is maintained across the external sensing resistor.

Load: For the maximum change in load resistance, within the rated compliance range, output current changes less than 0.1% when the specified voltage sample is maintained across the external sensing resistor.

The sensing resistor is chosen to produce a 1 volt drop at the maximum operating current. A separate control is used externally to provide high resolution current adjustability.

STABILITY: Output current varies less than 0.1% or 1 ma, whichever is greater, over a period of 8 hours after warmup. Measured at constant line voltage, load and ambient temperature.

TEMPERATURE COEFFICIENT: Output current changes less than 0.1% per °C.

RIPPLE: Less than 0.1% of maximum current, rms.

INPUT REQUIREMENTS: 100-130V AC, 60 cps \pm 1 cps single phase. Input current approximately 2 amperes, 200 watts. For models to operate at 104 \pm 13.5V AC; 115 \pm 15V AC; 208 \pm 27V AC or 230 \pm 30V AC, 50 cps, \pm 5%, add suffix "-50" to model number and derate output current by 20%.

AMBIENT OPERATING TEMPERATURE:

Uncased: -20°C to +65°C maximum

Cased: -20°C to +55°C maximum

STORAGE TEMPERATURE: -40°C to +85°C

ISOLATION VOLTAGE: A maximum of 500 volts can be connected between the chassis and either output terminal.

SPECIFICATIONS, Performance

CONTROLS: PWR Modules are supplied with a built-in \pm 5% trimmer adjustment which operates for voltage or current

control. The main output control is exercised by means of external resistances which may be fixed, stepped or variable. A fixed 1% resistor, selected to program the rated output voltage is supplied with each module. Stability and temperature coefficient criteria require the use of high quality LTC, 20PPM wire-wound elements for programming.

PROGRAMMING: Terminals provide for resistive programming of voltage or current at approximately 1000 ohms per volt. Programming terminals are also provided for programming by means of remotely located voltage or current signals. Output current derates linearly with voltage (see operating region characteristic). The current cutoff setting automatically tracks the voltage to provide proportionally constant overload protection.

OVERLOAD PROTECTION: The cutoff current limit is adjustable from approximately 5% to 105% of the rated output current. When overloaded, output current reduces along the cutoff line to approximately 5% of the rated maximum into a short circuit. Cutoff should be set to exceed the maximum expected *operating* current (I_{LIMIT}) by an amount equal to 5% of the *maximum* current rating of the power supply.

The negative resistance character of the cutoff locus may cause severely non-linear loads (requiring large starting surge currents) to "lock out" for certain settings of the cutoff current limit. For such loads, a series starting resistance can be used to limit the starting surge so that operation can be contained within the shaded region of the graph. Some examples of non-linear loads are: high intensity filament lamps and motors.

REMOTE ERROR SENSING: Error sensing terminals enable specified voltage regulation to be maintained directly at the load by compensating for voltage drops up to 0.5 volts across each load supply lead.

SERIES/PARALLEL OPERATION: Connections provided for series/parallel operation of identical units using master/slave configurations.

CONVECTION COOLING: Heat removal is by natural convection.

OVERSHOOT: No output voltage overshoot from turn-on, turn-off or power failure for output settings above 25% of maximum rated voltage. Below 25%, output overshoot is a function of load and is negligible for loads in excess of 10%.

SPECIFICATIONS, Physical

TERMINALS AND CONTROLS: *On Rear of Chassis:* Barrier strip terminals provide for AC input, DC output, remote error sensing, programming and ground terminals. Output terminals are isolated from ground, either positive or negative output may be grounded.

DIMENSIONS: *Uncased:* $6\frac{3}{4}"$ H x $4\frac{3}{4}"$ W x $10\frac{3}{8}"$ D
Cased: $6\frac{15}{16}"$ H x $5"$ W x $10\frac{7}{16}"$ D

STANDARD FINISH: *Chassis:* cadmium plated, cronak wash. *Case:* blue finished aluminum (special finishes to order).

ACCESSORIES: *Cased Units:* To specify cased unit, add suffix "C" to the model no. eg: PWR 15-6C for module with case. Case includes wrap-around, end plate and 4 removable feet for bench use.

RACK ADAPTERS:

RA 8-2: ($5\frac{1}{4}"$ H x 19" W) accommodates 2 PWR modules.
 RA 9-3: (7" H x 19" W) accommodates 3 PWR modules.
 RA 10-1: ($5\frac{1}{4}"$ H x 19" W) accommodates 1 PWR module.

Finish: Frosty etch, clear epoxy coating. (special finishes to order). See Accessory Page 43 for dimensional drawings.

CUSTOM OPTIONS: Special models available with custom ratings. Contact your nearest Kepco sales engineer with your special requirements.

kepco
 TRANSISTORIZED
design group

PWR
 REGULATED DC SUPPLY
MODULES

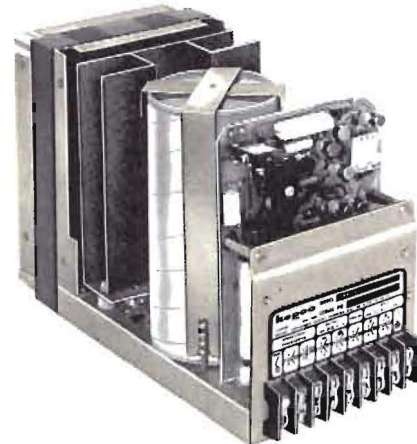

Uncased unit
 Model PWR 12-7

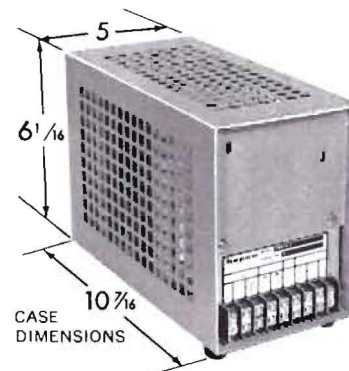
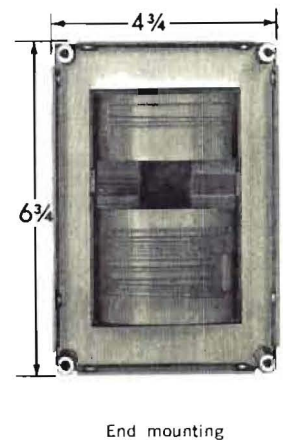
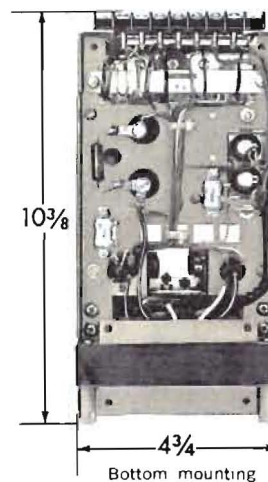
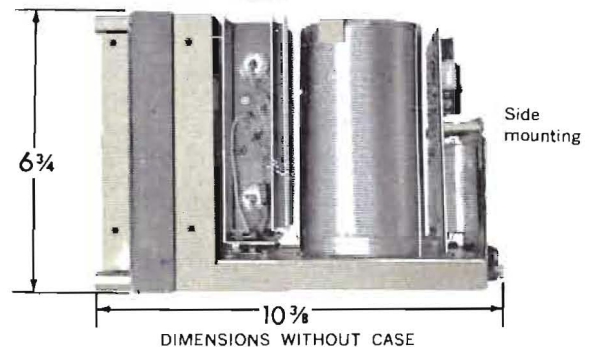

Data subject to change without notice
 PATENT NOTICE: Applicable Patent Nos. will be supplied on request.



kepco

TRANSISTORIZED
design group

- wide voltage range
- high current
- dual regulator
- minimum regulator dissipation

REGULATION 0.01% LINE — 0.05% LOAD

MODEL	DC OUTPUT RANGE		OUTPUT IMPEDANCE OHMS MAX.			DIMENSIONS			MAX. INPUT AMPS At 125 V AC
	VOLTS	AMPS	DC to 100 CPS	100 CPS to 1 KC	1 KC to 100 KC + μ H	H"	W"	D"	
SM 14-7M	0-14	0-7	0.001	0.005	0.1 +0.4	3½	19	13⅞	3.5
SM 14-15M	0-14	0-15	0.0005	0.005	0.02+0.4	5¼	19	13⅞	5.5
SM 14-30M	0-14	0-30	0.0003	0.005	0.02+0.1	8¾	19	13⅞	10.5
SM 36-5M	0-36	0-5	0.005	0.005	0.03+0.4	3½	19	13⅞	4.0
SM 36-10M	0-36	0-10	0.003	0.005	0.03+0.4	5¼	19	13⅞	6.5
SM 36-15M	0-36	0-15	0.002	0.005	0.03+0.4	8¾	19	13⅞	10.5
SM 75-2M	0-75	0-2	0.02	0.005	0.04+0.4	3½	19	13⅞	4.0
SM 75-5M	0-75	0-5	0.01	0.005	0.02+0.4	5¼	19	13⅞	6.5
SM 75-8M	0-75	0-8	0.005	0.005	0.06+0.5	8¾	19	13⅞	10.0
SM 160-1M	0-160	0-1	0.1	0.005	0.04+0.5	3½	19	13⅞	3.5
SM 160-2M	0-160	0-2	0.05	0.005	0.04+0.4	5¼	19	13⅞	5.5
SM 160-4M	0-160	0-4	0.02	0.005	0.06+1.0	8¾	19	13⅞	10.5
SM 325-0.5M	0-165-325	0-0.5	0.4	0.005	0.1 +1.0	3½	19	13⅞	3.5
SM 325-1M	0-325	0-1	0.2	0.005	0.1 +1.0	5¼	19	13⅞	5.0
SM 325-2M	0-325	0-2	0.1	0.005	0.1 +1.0	8¾	19	13⅞	11.0

SPECIFICATIONS, General

REGULATION:

LINE: 0.01% output voltage change for 105—125V AC line variation at any output voltage within the specified range.

LOAD: 0.05% or 1 millivolt output voltage change, whichever is greater, for NO LOAD to FULL LOAD change at any output voltage within the specified range.

STABILITY:

Output varies less than 0.05% or 3 millivolts, whichever is greater, over a period of 8 hours after warmup. Measured at constant line voltage, load and ambient temperature.

RIPPLE:

Less than 1 millivolt rms.

0.01% LINE AND LOAD REGULATION

MODELS AVAILABLE:

All of the listed SM Power Supplies available in a 0.01% regulated version on special order. Designate by adding the suffix "X" after the model number: e.g. SM 160-4MX. The "X" version has improved load regulation, rated 0.01% or 1 millivolt, whichever is greater, and improved stability, rated 0.01% or 2 millivolts over 8 hours.

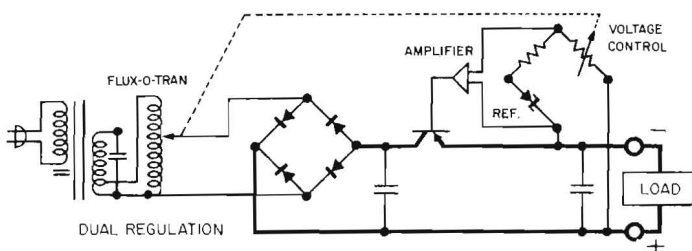

All models are designed for continuous operation without de-rating under all specified line, load and temperature conditions.

RECOVERY TIME:

50 microseconds.

TEMPERATURE COEFFICIENT:

Output voltage changes less than 0.05% per °C.

AMBIENT OPERATING TEMPERATURE:

-20°C to +50°C maximum. Protective circuit turns unit "off" should an over-temperature condition occur. Reset with power on-off switch.

STORAGE TEMPERATURE:

-40°C to +85°C maximum.

OUTPUT IMPEDANCE:

Specified for each model within the load frequency range shown in the table. Above 10 kc include the reactive impedance of the effective series inductance as indicated.

Data subject to change without notice.
PATENT NOTICE: Applicable Patent Nos.
will be supplied on request.



INPUT REQUIREMENTS:

105—125V AC 60±1 cps single phase.

Units operate within regulation specification for short term line frequency changes within the range 57—63 cps (except 325V Models).

For models to operate at 104 ± 9V AC; 115 ± 10V AC; 208 ± 18V AC or 230 ± 20V AC, 50 cps ± 1 cps add suffix "-50" to the model number and derate output *voltage* by 20%.

SPECIFICATIONS, Performance

CONTROLS:

Continuously adjustable 5-turn voltage control permits output settings from zero to the maximum output voltage. Resolution: 0.1% of maximum output voltage.

REMOTE ERROR SENSING:

Separate sensing terminals enable specified voltage regulation to be maintained directly at the load by compensating for voltage drops up to 0.5 volts across the load supply leads.

COOLING:

Lateral circulation by blowers insures efficient heat transfer; permits stacking of units without overheating.

OVERSHOOT:

No output voltage overshoot from turn-on, turn-off or power failure for output settings above 25% of max. rated voltage. Below 25%, output overshoot is a function of load and is negligible for loads in excess of 10%.

ISOLATION VOLTAGE:

A maximum of 400 volts can be connected between the chassis and either output terminal.

SPECIFICATIONS, Physical

METERS:

Model numbers in table include 2½" voltmeter and ammeter; 2% full scale accuracy. To specify unmetered unit, delete the suffix "M" from the model number, eg., SM 160-1 for unit without meters.

TERMINALS AND CONTROLS:

On front panel: DC output and ground (5-way) terminals. 5-turn continuously variable voltage control, power on-off switch (dual voltage range switch on SM 325-0.5M)

On rear of chassis: DC output and ground (5-way) terminals. Remote error sensing terminals. All output terminals are isolated from the chassis, either positive or negative terminal may be grounded. Three wire safety ground line cord.

DIMENSIONS:

Standard EIA rack dimensions.

See table for specification of each model. Depth is measured behind front panel.

STANDARD FINISH:

Gray hammertone (special finishes to order)

kepco
TRANSISTORIZED
design group



Model SM 14-7M



Model SM 160-2M



Model SM 325-2M

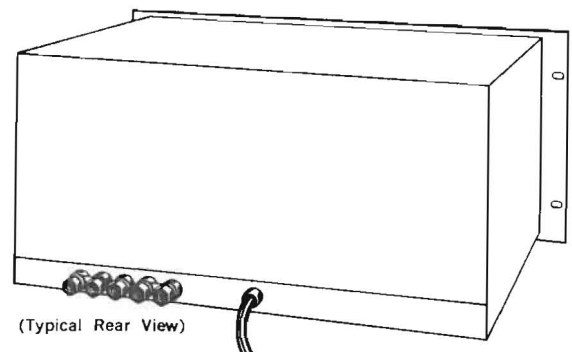

(Typical Rear View)



kepco
VACUUM TUBE
design group

SPECIFICATIONS, General

REGULATION:

(See table) the regulation of each model is specified as a percentage or minimum absolute change for 105—125V AC line variations and NO LOAD to FULL LOAD change. Percentage values measured to maximum rated output voltage.

STABILITY:

Output varies less than percent regulation specification or 100 millivolts whichever is greater over a period of 8 hours after warmup. Measured at constant line voltage, load and ambient temperature.

<0.1% REGULATION and STABILITY

MODEL	DC OUTPUT RANGE		REGULATION				RIPPLE RMS MV	OUTPUT IMPEDANCE OHMS MAX.			AUX. OUTPUT 6.3VAC Unregulated	DIMENSIONS			MAX. INPUT AMPS At 125 V AC	
	VOLTS	MA.	LOAD O-MAX %	ΔV	LINE %	ΔV		DC to 100 CPS	100 CPS to 1 KC	1 KC to 100 KC + μH		H	W	D		
2400 B #1	Bias	0-150	0-5	*	*	*	1	*	*	*		10½"	19"	17⅞"	5.0	
	#2	0-400	0-150	0.025	0.1	0.1	0.4	3	0.7	0.05	0.2+2					10 AMP
	#3	0-400	0-150	0.025	0.1	0.1	0.4	3	0.7	0.05	0.2+2					10 AMP
	Parallel #2 & #3	0-400	0-300	0.025	0.1	0.1	0.4	3	0.35	0.05	0.2+2					
	Series #2 & #3	0-800	0-150	0.025	0.2	0.1	0.8	6	1.4	0.1	0.4+4					
400 B	0-400	0-150	0.025	0.1	0.1	0.4	3	0.7	0.05	0.2+2	10 AMP	7"	19"	11⅞"	3.0	
	Bias 0-150	0-5	*	*	*	*	1	*	*	*						
430 D #1	0-450	0-300	0.025	0.1	0.1	0.4	3	0.38	0.05	0.2+2	10 AMP	12¼"	19"	17⅞"	8.0	
	#2	0-450	0-300	0.025	0.1	0.1	0.4	3	0.38	0.05	0.2+2					10 AMP
	Parallel #1 & #2	0-450	0-600	0.025	0.1	0.1	0.4	3	0.19	0.05	0.2+2					
	Series #1 & #2	0-900	0-300	0.025	0.2	0.1	0.8	6	0.76	0.1	0.4+4					
800 B #1	0-600	0-200	0.02	0.1	0.1	0.4	3	0.6	0.05	0.2+2	10 AMP	12¼"	19"	17⅞"	7.5	
	#2	0-600	0-200	0.02	0.1	0.1	0.4	3	0.6	0.05	0.2+2					10 AMP
	Parallel #1 & #2	0-600	0-400	0.02	0.1	0.1	0.4	3	0.3	0.05	0.2+2					
	Series #1 & #2	0-1200	0-200	0.02	0.2	0.1	0.8	6	1.2	0.1	0.4+4					
605	0-600	0-500	0.02	0.1	0.1	0.4	3	0.24	0.05	0.2+2	20 AMP	10½"	19"	17⅞"	8.0	
	Bias 0-150	0-5	*	*	*	*	1	*	*	*						
615B	0-600	0-300	0.02	0.1	0.1	0.4	3	0.4	0.05	0.2+2	10 AMP	10½"	19"	13⅞"	6.0	
	Bias 0-150	0-5	*	*	*	*	1	*	*	*						
103	#1	0-300	0-75	Common B-#3 isolated from #1 and #2	Unregulated		30	—	—	—	5 AMP	8"	16"	8"	1.5	
	#2	0-300	0-75				30	—	—	—						
	#3	50 to +50	0-5				10	—	—	—						
	Parallel #1 & #2	0-300	0-150				30	—	—	—						
1250 B	0-1000	0-500	0.01	0.1	0.05	0.4	3	0.2	0.1	1.0+2		28"	22"	15½"	12.5	
1220 C	0-1200	0-50	0.01	0.1	0.05	0.4	3	2.4	0.2	1.0+2	10 AMP	10½"	19"	13"	3.0	
1520 B	0-1500	0-200	0.01	0.1	0.05	0.4	3	0.75	0.3	1.0+5		23"	22"	15½"	7.0	
HB 2050	0-2000	0-500	0.005	0.05	0.01	0.1	3	0.2	0.5	2.0+5		33½"	22"	18"	24.0	
HB 2500	0-2500	0-50	0.005	0.05	0.01	0.05	5	2.5	0.5	2.0+5		8¾"	19"	17"	5.0	

RIPPLE:

See table for maximum specification applicable to each model.

RECOVERY TIME:

50 microseconds.

TEMPERATURE COEFFICIENT:

Output voltage changes less than 0.01% per °C.

AMBIENT OPERATING TEMPERATURE:

-20°C to +55°C maximum.

STORAGE TEMPERATURE:

-40°C to +85°C maximum.

OUTPUT IMPEDANCE:

Specified for each model within the load frequency range shown in the table.

Above 10 kc include the reactive impedance of the effective series inductance as indicated.

INPUT REQUIREMENTS:

105—125V AC 50—65 cps single phase.

Units are available with 50—440 cps input tolerance on special order.

*** REGULATION FOR BIAS OUTPUTS:**

In the range 0—150V DC the output voltage variation is less than 0.01% for line fluctuations from 105 to 125 volts. At 150 volts the output varies less than 2% for

load changes from 0—5 milliamperes. At settings below 150 volts, the internal resistance of the bias supply increases to a maximum of 25,000 ohms. The bias output is a negative potential derived from a VR tube energized by a regulated supply; it is referred to the negative output terminal of the main supply. The nominal maximum output voltage is 150V DC and can be anywhere in the range 140-165V DC.

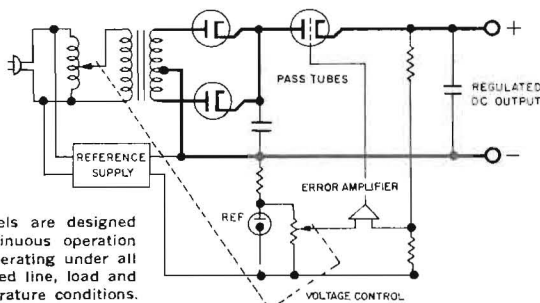

All models are designed for continuous operation without derating under all specified line, load and temperature conditions.

Data subject to change without notice
PATENT NOTICE: Applicable Patent Nos. will be supplied on request.



SPECIFICATIONS, Performance

CONTROLS:

Continuously adjustable single-turn voltage control permits output settings from zero to the maximum output voltage. Models 2400B, 430D, 800B and HB 2500 incorporate coarse and fine adjustments. The fine controls cover a range of approximately 1% of rated maximum output voltage. (Fine controls available for all other models on special order.)

Resolution: 0.5% of maximum output voltage. Units with fine controls have a resolution of 0.005% of maximum output voltage.

CONVECTION COOLING:

Heat removal is by natural convection, no blowers.

ISOLATION VOLTAGE:

A maximum of 400 volts can be connected between the chassis and either output terminal.

SPECIFICATIONS, Physical

METERS:

Model numbers in table include voltmeter and ammeter, (except Model 103, supplied unmetred only).

TERMINALS AND CONTROLS:

On front panel: DC output and ground (5-way) terminations, 6.3V AC output terminals (where applicable), AC on-off switch, pilot light and fuse. DC on-off switch, pilot light and fuse. Voltage controls. For Models 2400 B, HB 2050 and HB 2500, output terminals are provided at the rear only.

On rear of chassis: DC output and ground terminations, 6.3 V AC output terminals (where applicable). For Model 103, output terminals are provided on the front panel. All output terminals are isolated from the chassis, either positive or negative output may be grounded.

DIMENSIONS:

Standard EIA rack dimensions. See table for specification of each model. Depth is measured behind front panel.

Models marked with a ♦ are supplied in cabinets. The chassis, when removed from their cabinets will mount directly into a standard 19" wide equipment rack.

		H	W	D
The equipment dimensions are:	1250B	26¼"	19"	13⅞"
	1520B	21"	19"	13⅞"
	HB 2050	31½"	19"	17⅞"
	103	(Use with Rack Adapter RA-1)		

STANDARD FINISH:

Gray hammertone (special finishes to order).

kepco
VACUUM TUBE
design group



Model 1520B ♦



Model 430D



Model HB 2500



NOMOGRAPH OF VOLTAGE DROP ACROSS LOAD SUPPLY LEADS (as a function of wire size and load current)

THIS NOMOGRAPH CAN BE USED TO FIND:

Maximum current carrying capacity recommended for any standard wire size.*

- 1) With a straight edge, connect from the wire size on Scale 2 to the point "A" on Scale 3.
- 2) Read I_{max} on Scale 1.

Voltage drop in millivolts per foot for known wire size and operating current.

- 1) With a straight edge, connect the known current on Scale 1 and the wire size on Scale 2.
- 2) Read voltage drop on Scale 3.

Wire size required for known operating current and known maximum tolerable voltage drop across supply leads.

- 1) Determine maximum tolerable drop in millivolts per foot of lead (sum of positive and negative leads).
- 2) Connect the value on Scale 3 (as determined in step 1) to the known current on Scale 1.
- 3) Read wire size on Scale 2.

*Based on an arbitrary minimum 500 circular mils per ampere. High-temperature class insulation will safely allow higher currents.

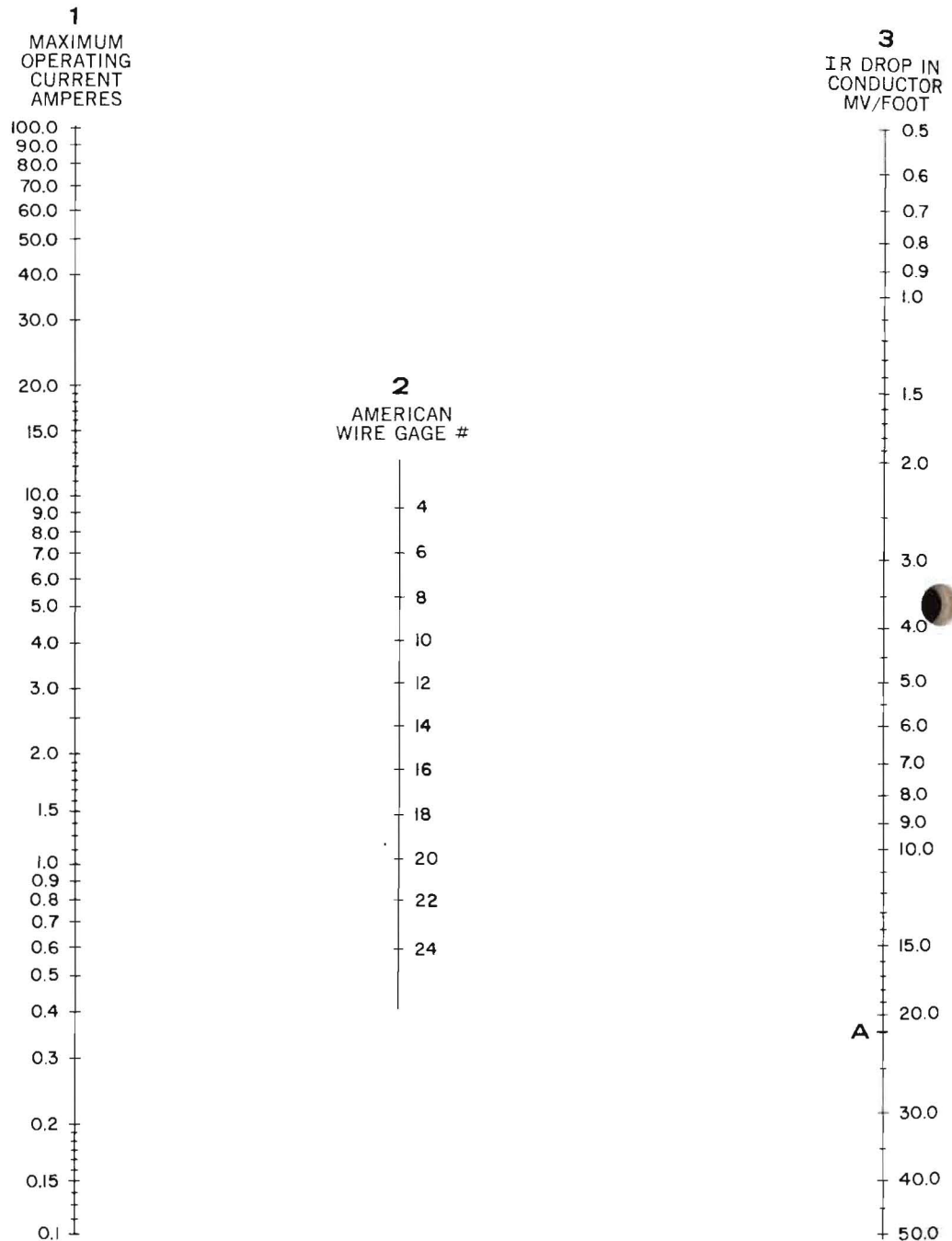

NOTE: A voltage regulated Power Supply controls the voltage across its output terminals. Hence the wire conductors used to connect the load must be considered as part of the load. At high load currents the voltage drop across the supply leads may appreciably degrade regulation at the load. Kepco models equipped with the remote error sensing feature can automatically compensate for voltage drops of up to 500 mv across each load supply lead.



ACCESSORY EQUIPMENT

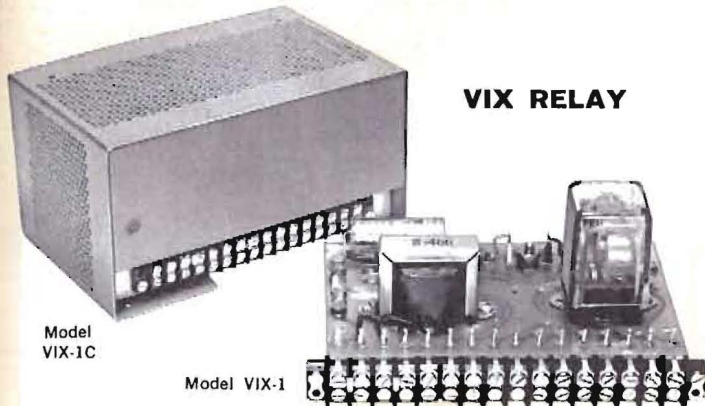

VIX RELAY

Model VIX-1C

Model VIX-1

Model VIX-1C translates the VIX REMOTE SIGNAL available on all CK and KS VIX-equipped power supplies into a heavy duty relay closure for external control or signal applications.

SPECIFICATIONS

INPUT: $\pm 8V$ DC at 1 ma (from VIX signal).

OUTPUT: Three pole, double throw relay contacts; each rated to carry 10 amperes at 115V AC or 5 amperes at 230V AC.

POWER REQUIREMENTS: 105-125V or 210-250V AC

SIZE: $4\frac{1}{4}$ " H x $8\frac{5}{32}$ " W x 5" D ($5\frac{3}{8}$ " D overall) Standard half-rack configuration).

MOUNTING: In the half-rack enclosure VIX-1C can be mounted in either RA-4 or RA-5 rack adapters.

The enclosure is removable so that the circuit board, which is complete by itself, can be mounted within other equipment or chassis. To designate model without enclosure, delete the suffix "C", e.g., Model VIX-1, for unenclosed circuit board for "built-in" mounting.

MOTORIZED PROGRAMMER MODEL MP-1-3000

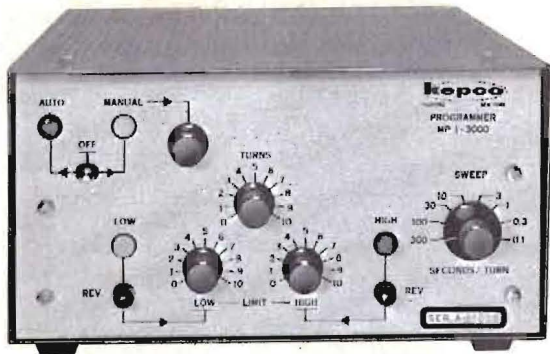

Model MP-1-3000 is a mechanically driven resistance programmer suitable for use with any Kepeco programmable power supply or resistance driven mechanism. It consists of a synchronous motor which drives a precision 10-turn servo-mount potentiometer through a multi-speed reversible gear box.

SPECIFICATIONS

OUTPUT RANGE: The output is a variable resistance which can be selected from among the following standard values:

10 ohms, 25 ohms, 50 ohms, 100 ohms, 200 ohms, 500 ohms, 1000 ohms, 2000 ohms, 5000 ohms, 10K, 20K, 30K, 50K, 75K, 90K, 100K and 125K.

The selected resistance represents the full range resistance of available potentiometers. Designate when ordering by appending the resistance value to the model number, for example: for a 10,000 ohm potentiometer, order MP-1-3000-10 K. Other resistance values available on special order.

SPEEDS: 8 speeds from 300 seconds per revolution (3000 seconds for the full 10 turns) to 0.1 seconds per revolution (1 second full range), switch selected from the front panel: 300 sec/rev, 100 sec/rev, 30 sec/rev, 10 sec/rev, 3 sec/rev, 1 sec/rev, 0.3 sec/rev and 0.1 sec/rev. Other speeds available on special order.

TIMING: Programming speeds referenced to 60 cps line frequency. Overall timing accuracy better than $\pm 5\%$ at 60 cps line frequency.

LIMITS: Mechanically adjustable high and low limit switches automatically reverse the direction of rotation of the potentiometer shaft when it reaches the respective limit points. The limits can be set to restrict shaft travel from 10 revolutions to as little as $\frac{1}{4}$ revolution, in any portion of the 10-turn sweep range.

OVERRIDE: Manual override buttons permit the operator to reverse the program direction at any desired point, or to stop the mechanism at will.

DIRECTIONAL LAMPS: Two pilot lights are employed to signal the direction of potentiometer rotation.

STOP: The mechanical programmer can be stopped — either electrically or manually at any point in its sweep range. While stopped, the program shaft can be manually rotated.

PROGRAMMING: When used to program the voltage or current function of any Kepeco supply, the potentiometer resistance should be selected by multiplying the desired maximum output voltage by the control ratio of the supply in question. For example: to program up to 40 volts from a Kepeco Model ABC 40-0.5M, a 40K potentiometer is required ($40V \times 1000$ ohms per volt); choose 50K, the closest standard value.

Potentiometers are easily interchanged to control a variety of power supplies and functions.

INPUT REQUIREMENTS: 105-125V AC, 60 cps.

SIZE: $4\frac{1}{4}$ " H x $8\frac{5}{32}$ " W x 9" D ($9\frac{3}{8}$ " overall); standard half-rack configuration; fits Rack Adapters RA-4 or RA-5.

PROGRAMMER FUNCTION GENERATOR, MODEL FG-100



Model FG-100 is a precision, slow speed, triangular wave-form generator capable of generating any repetitive ramp function. Separately adjustable, high and low limits, are provided which periodically reverse the direction of the integration. The rising rate and falling rate are separately adjustable or can be controlled symmetrically with a single control.

SPECIFICATIONS

OUTPUTS:

- #1 — 0-20V DC, 0-20 ma.
 - #2 — 0-10 ma to program 100 ohm/volt power supply.
 - #3 — 0-1 ma to program 1000 ohm/volt power supply.
- All outputs available simultaneously.

INPUT: 105-125V or 210-250V AC, 50-440 cps.

TIMING: 4 ranges: 0.1V/sec., 1.0V/sec., 10V/sec., 100V/sec.

Rising and falling slopes continuously adjustable between ranges either separately or symmetrically. For outputs #2 and #3, divide the above timing by 2000 and 20,000 respectively to obtain milliamperes per second.

LIMITS: Separately adjustable high limit and low limit permits operation between any two pre-set voltages or currents.

REVERSING SWITCHES: Programming direction is automatically reversed at the high and low limits. In addition, a pair of push buttons are provided which permit the direction to be reversed at any point in the operating span. A pair of directional lamps are provided to show the direction of the ramp.

METER: 2½" edgewise meter monitors output in volts (0-20V DC) and in percent of maximum output, 0-100%.

PROGRAMMING: Model FG-100 may be used by itself to generate a wide variety of very low speed triangular or sawtooth functions, or it can be used directly with any programmable DC power supply. When connected to a programmable power supply, the Model FG-100 Function Generator programs the power supply throughout all or part of its rated voltage or current range as set by the power supply's controls and the function generator's limit settings. NOTE: function speed is converted to programming speed by multiplying the driving current rate (ma/sec.) by the resistance setting of the voltage control of the power supply being programmed. This gives the programming speed of the power supply's output in volts per second.

REMOTE CONTROLS: Timing and limit setting controls are brought to a multi-terminal barrier strip at the rear of the unit for remote operation. A sync output is also provided as is provision for remote directional signals.

SIZE: 4¼" H x 8½" W x 13" D (13¾" D overall); standard half-rack configuration, fits Rack Adapters RA-4 and RA-5.

PROGRAMMING PANELS

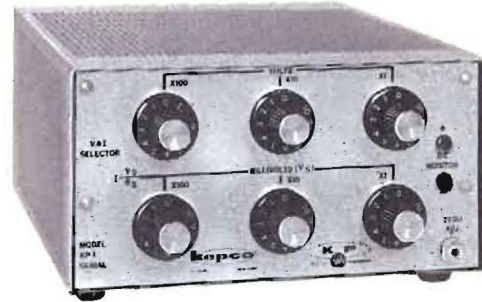

MODEL KP-1 for use with Kepco ABC, CK and PAX Groups of Regulated Power Supplies. (1 milliampere Kepco Bridge Circuit).

SPECIFICATIONS: MODEL KP-1

DECADES: 6-digit voltage programming. 3-digit current programming.

RANGE: 0-1,011.110 ohms in 1 ohm steps (0 to 1,011.110V in 1 millivolt steps at 1000 Ω/V).

ACCURACY: Decades contain 0.1% resistor except units decade (millivolts) which contain 1% resistors.

SIZE: Half-rack, 4¼"H x 8½"W x 9⅝"D. Fits Rack Adapters RA-4 or RA-5.



MODEL KP-10 for use with Kepco HB and KS Groups of Power Supplies. (10 milliampere Kepco Bridge Circuit.)

SPECIFICATIONS: MODEL KP-10

DECADES: 6-digit voltage programming. 3-digit current programming.

RANGE: 0-101,111.0 ohms in 0.1 ohm steps (0-1,011.110V in 1 millivolt steps at 100 Ω/V.)

ACCURACY: All decades contain 0.1% resistors.

SIZE: 3½"H x 19"W x 11"D. Standard rack mount configurations.

Both decade programmers contain provision for current programming using the first three digits. This assumes a 1 volt sensing drop (internal or external). If the recommended 10 volt sample is employed for HB and ABC high voltage hybrids, then a fourth digit can be used for higher resolution.

When substituted in place of a power supply's normal voltage control and calibrated, the KP-1/KP-10 digital decade programmer converts that supply to a highly accurate voltage or current source.

Both programmers contain zero trimming controls which, in conjunction with the power supplies own bridge current adjustment, allow precise calibration of the output at minimum and maximum output. The programming function of the Kepco bridge is inherently linear to an accuracy determined by the load/line regulation of the power supply. This means that the circuit accuracy is, for all intents and purposes, limited solely by the resistors used in the programmer.

OVER-VOLTAGE / OVER-CURRENT PROTECTORS



MODEL VIP-1 OVER-VOLTAGE/OVER-CURRENT

MODEL VIP-3 OVER and UNDER-VOLTAGE/OVER and UNDER-CURRENT

MODEL VIP-4 200 AMPERE OVER-VOLTAGE CROWBAR

The VIP consists of a sensing circuit capable of detecting a voltage 1% or 0.1 volts different than any preset voltage limit in the range 5–200 volts. Should such an over or under-voltage occur, a fast-acting silicon controlled rectifier (SCR) "crowbar" short circuits the power supply's output within 50 microseconds. Simultaneously a power interlock relay is tripped which removes the primary AC power within approximately 50 milliseconds. The SCR discharges the power supply's output filter capacitor and the voltage is reduced to zero.

Operation in the internal reference mode allows the operator to pre-set any voltage as a limit above or below which crowbar/turn-off action is precipitated. In its tracking mode, the VIP is interconnected with the voltage control circuit of the power supply with which it is used and will sense a voltage differential between the output of the supply and the programmed voltage.

Terminals are provided for the addition of a sensing resistor to convert VIP into an over-current or under-current protector depending on model. The current sensing resistor is chosen to drop 1 volt at the operating current. The sensitivity control then adjusts the firing threshold from 0 to the operating current, maximum 30 amperes.

SPECIFICATIONS:

VOLTAGE

SENSITIVITY: Minimum threshold 1% of operating voltage or 0.1 volts whichever is greater (adjustable).

RANGE: 0–50V*, 50–100V, 100–150V, 150–200V.

*Minimum voltage required for proper operation is 5V.

CURRENT

SENSITIVITY: 5% of operating current producing a 1 volt drop across external sensing resistor.

RANGE: 0-30 amperes. Model VIP 4 has a 0-200 ampere crowbar range.

POWER INTERLOCK RELAY

CONTACT RATING: 10 amperes at 115V AC.

Operation of the VIP is in two stages. The output crowbar is immediately followed by an AC power interruption to the crowbarred power supply. High power supplies (such as might require a VIP 4) may require either an auxiliary contactor to turn them off, or, in the case of the large KS and KO models, a connection may be made to the trip coil of the power supply's circuit breaker to accomplish the turn-off action.

DIMENSIONS

3½" high x 19" wide x 8" deep.

Standard EIA rack dimensions.

FINISH: Gray hammertone (special finishes to order).

Note: Because PNP transistors are used as the series pass elements in Keppo All-Transistor Power Supplies; their reference polarity is reversed relative to Hybrid Models which employ a vacuum tube for this function. When a VIP is to be used in its "Tracking Mode" be sure to specify (when ordering) whether it is to be used with an All-Transistor or a Hybrid Power Supply.

DATA SUBJECT TO CHANGE WITHOUT NOTICE

PATENT NOTICE: Applicable Patent Nos. will be supplied on request

Model KT 6212 VARIABLE RESISTIVE LOAD



The Model KT 6212 is a multiganged, eight-section group of dual-wound power rheostats used in the testing of regulated power supplies.

Model KT 6212 consists of two independent gangs of four rheostats apiece, 0-64 ohms and 0-1000 ohms. The rheostats can be switched for parallel, series parallel and series operation. Since each rheostat has heavy and light windings, the maximum permissible load current changes at approximately each third rotation point around the dial. The maximum current for each arc is clearly given on the Model KT 6212 panel.

CONTROLS:

Three bands encircle each control knob marked PP, SP and SS, respectively. SS means that both range switches for that gang are in their S (series) positions and all four rheostats in that gang are in series. SP indicates that one switch is in S (series) and the other is in P (parallel). The four rheostats may be either paired in series (with the two pairs in parallel), or they may be paired in parallel with the two pairs in series. The load resistance result is identical in either case. The PP (parallel-parallel) band defines the ratings when all four rheostats are in parallel.

Each band defines the resistance range for its particular connection with zero ohms (maximum current) in the clockwise position. The bands are divided into three sections that correspond to the position of the heavy and light windings, respectively. The maximum current in each section is shown on the corresponding portion of the band.

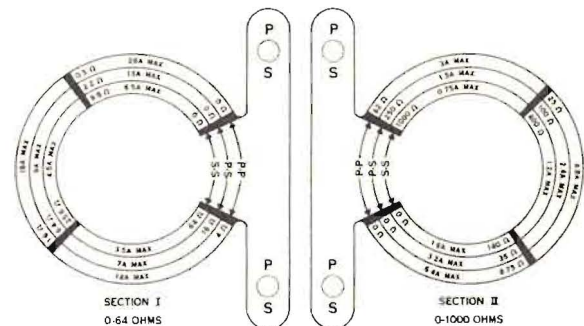

FUSING:

Each rheostat in the 0-64 ohm gang is fused at 7 amperes. Each rheostat of the 0-1000 ohm gang is fused for 2 amperes.

TERMINALS:

A pair of 5-way binding posts is provided at each gang for connection to the power source under test. These connections are duplicated at the rear.

EXTERNAL POWER REQUIREMENTS:

None. The Model KT 6212 is a passive device.

DIMENSIONS:

Height 8¾", width 19", depth 13⅝". The Model KT 6212 resistive-load is designed for mounting in standard 19" equipment racks.

ACCESSORY EQUIPMENT FOR OPS, PAX and PBX MODULAR SUPPLIES



To order a complete assembly of PAX/PBX/OPS modules (any mix) the following accessory components are required:

4-RACK

- (4) Cased Modules
- (4) RAP 7-4 Panel Adapters
- (1) RA 7-4 Rack Cabinet
- (1) RA 7-4BP Back Plate

6-RACK

- (6) Cased Modules
- (6) RAP 6-1 Panel Adapters
- (1) RA 6-6 Rack Cabinet
- (1) RA 6-6BP Back Plate

(Back plates are complete with mounted PC-1 plug in connectors) Guide pins for keying the mounting slots are packed with the panel adapters. If fewer than a full set (4 or 6 modules) are to be mounted, filler panels may be used in the blank spaces. Single, double, and triple width panels are available for Rack Cabinets RA 6-6 and RA 7-4. Filler panels can also be used to mount accessory equipment in the cabinets.

RACK CABINET: RA 6-6 for mounting six units

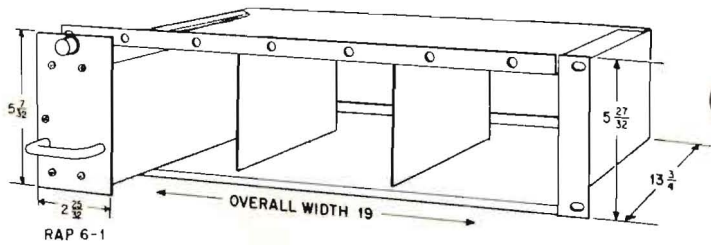

RACK CABINET: RA7-4 for mounting four units

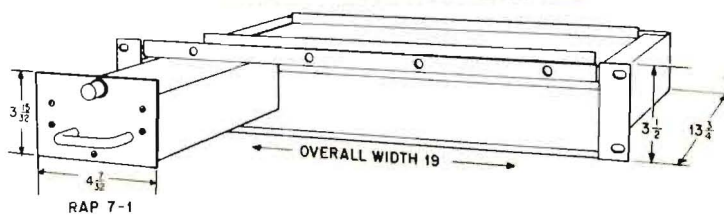

PANEL ADAPTERS: Required to mount the Modules in RA 6-6 and RA 7-4. Complete with handle and fastener.

RAP 6-1 Panel Adapter | **RAP 7-1** Panel Adapter

FILLER PANELS: Blank (undrilled) panel adapters with fastener to fill unused spaces in RA 6-6 or RA 7-4, can be used to mount other equipment in rack cabinets.

RFP 6-1 Single Filler | **RFP 7-1** Single Filler

RFP 6-2 Double Filler | **RFP 7-2** Double Filler

RFP 6-3 Triple Filler | **RFP 7-3** Triple Filler



PLUG-IN CONNECTOR: PC-1

Available separately to mate with the printed circuit card of the Modules. Pin spacing 0.156", keyed on pin 7 (Equivalent to Methode #CD612S P7 or Cinch #250-12-37-200).

BACK PLATES: Complete with six and four connectors respectively, mate with printed circuit card connectors, adapt the Rack Cabinets for plug-in mounting of the Modules. Back plates are drilled with coding holes which allow the designer to restrict the interchangeability of modules at will.

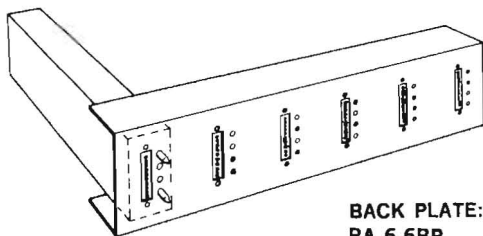

6 POSSIBLE HOLE-PLUG CODES

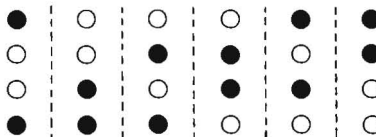

4 SOCKETS PROVIDED WITH 2 PINS AND 2 HOLE-PLUGS WHICH CAN BE INTERCHANGED TO CODE THE MOUNTING POSITIONS.

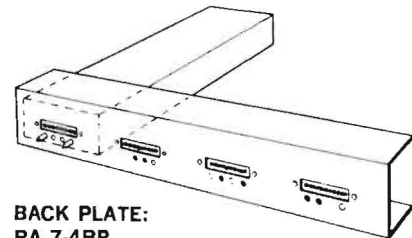

AUTOTRANSFORMERS

MODEL	POWER	L	SIZE* W	D
AT-100	100 VA	5 1/2"	2 7/8"	2 3/4"
AT-250	250 VA	6"	3 1/2"	3 1/2"
AT-500	500 VA	7 1/2"	3 1/2"	4 1/2"
AT-1000	1000 VA	8"	5 1/4"	5 1/4"
AT-1500	1500 VA	9 1/4"	5 1/4"	6 1/2"

*Overall case dimensions (not including handle and feet)



Compact step-down Transformers provide 115V AC output from 220/230/240V AC (tap selected) 48—440 cps.

RACK ADAPTERS

Rack Adapters are manufactured by Kepco to adapt bench style, modular and half-rack Power Supplies to the standard 19" wide equipment rack or cabinet.

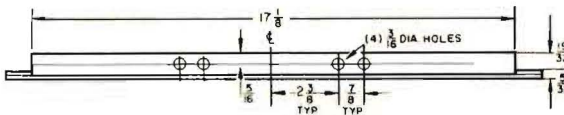
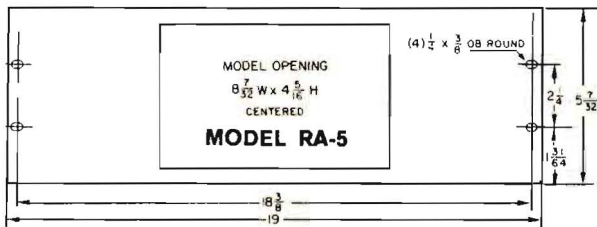
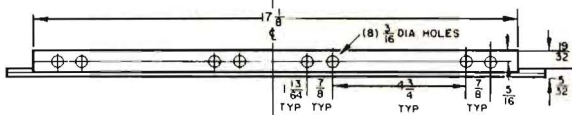
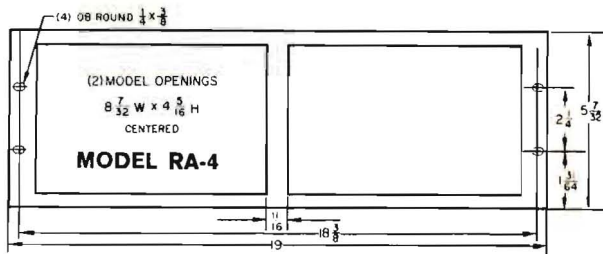
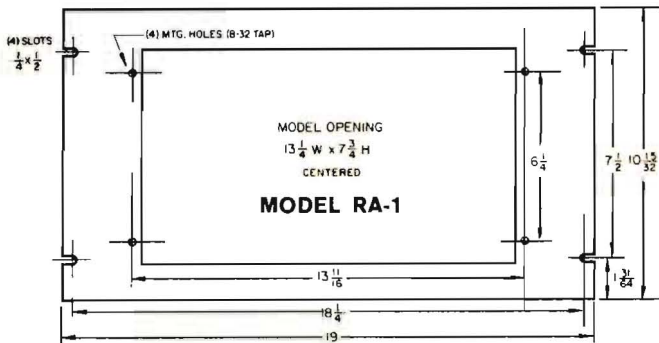

MODEL	HEIGHT	MOUNTING ARRANGEMENT	FOR USE WITH
RA 1	10 1/2"	Single	Model 103
RA 4	5 1/4"	Dual	ABC, CK and OPS-1A
RA 5	5 1/4"	Single	ABC, CK and OPS-1A

FP 1 (Filler Panel for use with Rack Adapter RA 4)

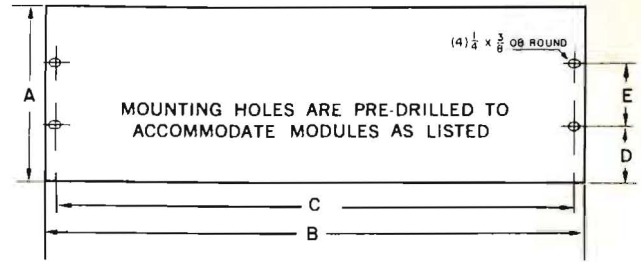

RACK ADAPTERS FOR PRM (Size A) and PWR MODULES

MODEL	DIMENSIONS					MOUNTS
	A	B	C	D	E	
RA 10-1	5 7/32"	19"	18 3/8"	1 3/64"	2 1/4"	1 Module
RA 8-2	5 7/32"	19"	18 3/8"	1 3/64"	2 1/4"	2 Modules
RA 9-3	6 3/32"	19"	18 3/8"	1 3/64"	4"	3 Modules

RACK ADAPTERS FOR PRM (Size B) MODULES

MODEL	DIMENSIONS					MOUNTS
	A	B	C	D	E	
RA 15-1	3 1/32"	19"	18 3/8"	1 3/64"	3"	1 Module
RA 14-3	3 1/32"	19"	18 3/8"	1 3/64"	3"	3 Modules
RA 16-4	5 7/32"	19"	18 3/8"	1 3/64"	2 1/4"	4 Modules
RA 17-5	5 7/32"	19"	18 3/8"	1 3/64"	2 1/4"	5 Modules

RACK ADAPTERS FOR PRM (Size C) MODULES

MODEL	DIMENSIONS					MOUNTS
	A	B	C	D	E	
RA 18-1	5 7/32"	19"	18 3/8"	1 3/64"	2 1/4"	1 Module
RA 8-2	5 7/32"	19"	18 3/8"	1 3/64"	2 1/4"	2 Modules
RA 9-3	6 3/32"	19"	18 3/8"	1 3/64"	4"	3 Modules

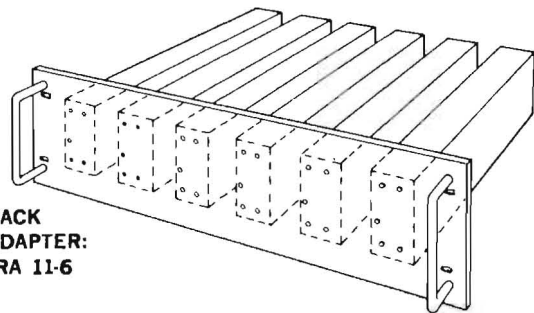

RACK ADAPTERS FOR CASED MODULES (Suffix C) OPS, PAX and PBX DESIGN GROUPS

MODEL	DIMENSIONS					MOUNTS
	A	B	C	D	E	
RA 12-1	3 15/32"	19"	18 3/8"	1 5/64"	3"	1 Module
RA 13-4	3 15/32"	19"	18 3/8"	1 5/64"	3"	4 Modules
RA 11-6	5 7/32"	19"	18 3/8"	1 3/64"	2 1/4"	6 Modules

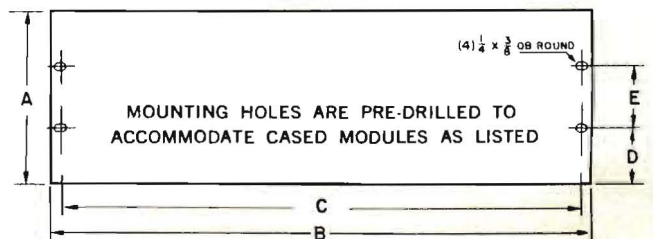



GLOSSARY OF POWER SUPPLY TERMS

This glossary is published to assist the engineer in the proper application and understanding of Kepco Regulated Power Supplies. The glossary gives the precise definition for every term that is used in describing and specifying Kepco Power Supplies.

ACCURACY:

Accuracy, used as a specification for the output voltage of fixed voltage power supplies, refers to the absolute voltage tolerance with respect to the stated nominal output.

AMBIENT OPERATING TEMPERATURE (Range):

The range of environmental temperatures in which a power supply can be safely operated. For units with forced air cooling, the temperature is measured at the air intake.

BIPOLAR:

Having two poles, polarities or directions. Applied to amplifiers or power supplies, it means that the output may vary in either polarity from zero; as a symmetrical program, it need not contain a d-c component. (See Unipolar)

BRIDGE CURRENT:

The circulating control current in the comparison bridge; bridge current equals the reference voltage divided by the reference resistor. Typical values are 1 ma and 10 ma corresponding to control ratios of 1000 ohms/volt and 100 ohms/volt respectively.

CALIBRATION, PROGRAMMING:

Calibration with reference to power supply programming describes the adjustment of the control bridge current to calibrate the programming ratio in ohms per volt. Many programmable supplies incorporate a "calibrate" control as part of the reference resistor which performs this adjustment.

CLOSED-LOOP GAIN (Operational Gain):

The gain, measured with feedback, is the ratio of the voltage appearing across the output terminal pair to the causative voltage required at the input resistor. The closed-loop (operational) gain is denoted by the symbol G in diagrams and equations. If the open-loop gain A is sufficiently large, the closed-loop gain can be satisfactorily approximated by the ratio of the feedback resistor R_f to the input resistor R_i . (See Open-loop, Loop gain)

COMMAND REFERENCE:

In a servo or control system, the voltage or current to which the feedback signal is compared. As an independent variable, the command reference exercises complete control over the system output. (See Operational programming)

COMPARISON AMPLIFIER

A high gain, noninverting d-c amplifier which, in a bridge regulated power supply, has as its input the voltage between the null junction and the common terminal. The output of the comparison amplifier drives the series pass elements.

COMPARISON BRIDGE:

A type of voltage comparison circuit whose configuration and principle of operation resemble a

four-arm electrical bridge (Figure 1). The elements are so arranged that, assuming a balance exists in the circuit, a virtual zero error signal is derived. Any tendency for the output voltage to change in relation to the reference voltage creates a corresponding error signal, which, by means of negative feedback, is used to correct the output in the direction toward restoring bridge balance. (See Error Signal).

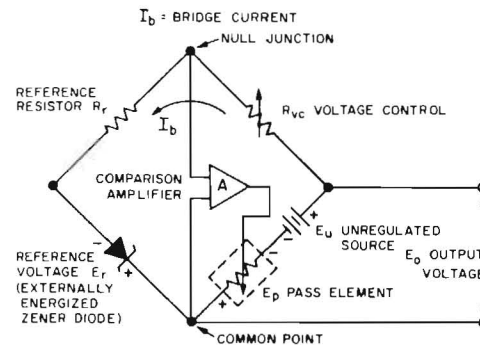

Figure 1: Kepco comparison bridge connected as a voltage regulator.

COMPLEMENTARY TRACKING:

A system of interconnection of two regulated supplies in which one (the master) is operated to control the other (the slave). The slave supply voltage is made equal (or proportional) to the master supply voltage and of opposite polarity with respect to a common point. (See Figure 2).

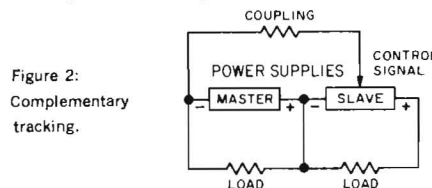

Figure 2: Complementary tracking.

COMPLIANCE EXTENSION:

A form of master/slave interconnection of two or more current regulated power supplies to increase their compliance voltage range through series connection.

COMPLIANCE VOLTAGE:

The output voltage of a d-c power supply operating in constant current mode. The compliance range is the range of voltages needed to sustain a given value of constant current throughout a range of load resistances.

CONSTANT CURRENT POWER SUPPLY (Current Regulator):

A power supply capable of maintaining a preset current through a variable load resistance. This is achieved by automatically varying the load voltage in order to maintain the ratio E_{load}/R_{load} constant.

CONSTANT VOLTAGE POWER SUPPLY

(Voltage Regulator):

A power supply that is capable of maintaining a preset voltage across a variable load resistance. This is achieved by automatically varying the output current in order to maintain the product of load current times load resistance constant.

CONTROL RATIO:

The required change in control resistance to produce a one volt change in the output voltage. The control ratio is expressed in ohms per volt and is the reciprocal of the bridge current.

COOLING:

In power supplies, the cooling of regulator elements refers to the method used for removing heat generated in the regulating process. Methods include radiation, convection, and conduction or combinations thereof.

COOLING, CONVECTION:

A method of heat transfer which uses the natural upward motion of air warmed by the heat dissipators.

COOLING, LATERAL FORCED AIR:

An efficient method of heat transfer by means of side to side circulation which employs blower movement of air through or across the heat dissipators.

CROSSOVER (Automatic) VOLTAGE/CURRENT:

The characteristic of a power supply that automatically changes the method of regulation from constant voltage to constant current (or vice versa) as dictated by varying load conditions (Figure 3). The constant voltage and constant current levels can be independently adjusted within the specified voltage and current limits of the power supply. The intersection of constant voltage and constant current lines is called the crossover point (E, I) and may be located anywhere within the volt-ampere range of the power supply.

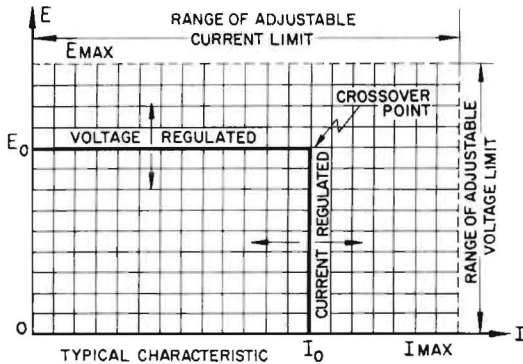
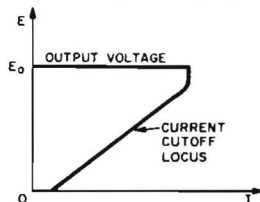

Figure 3: Automatic voltage/current crossover.

CURRENT CUTOFF:

An overload protective mechanism designed into certain regulated power supplies to automatically reduce the load current as the load resistance is reduced. This "negative resistance" characteristic reduces overload dissipation to negligible propor-

Figure 4: Output characteristic of a power supply equipped with a current cutoff overload protector.



tions and protects sensitive loads. See Figure 4 for the E, I characteristic of a power supply equipped with a current cutoff overload protector.

CURRENT LIMITING (Automatic):

An overload protection mechanism which limits the maximum output current to a preset value, and automatically restores the output when the overload is removed (See Short Circuit Protection, Figure 5).

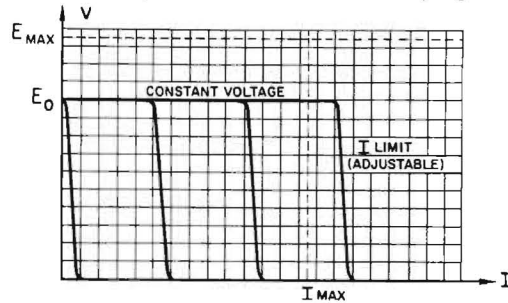

Figure 5: Plot of typical current limiting curves.

CURRENT SENSING RESISTOR:

A resistor placed in series with the load to develop a voltage proportional to load current. A current regulated d-c power supply regulates the current in the load by regulating the voltage across the sensing resistor.

"DELTA", MINIMUM

A qualifier, often appended to a percentage specification to describe that specification when the parameter in question is a variable, and particularly when that variable may approach zero. The qualifier is often known as the "minimum delta V", or "minimum delta I" as the case may be.

DRIFT:

See Stability

ERROR SIGNAL:

The error signal is the difference between the output voltage and a fixed reference voltage compared in ratio by the two resistors at the null junction of the comparison bridge $\epsilon = E_o - E_r \left(\frac{R_{cc}}{R_r} \right)$, see Figure 1,

The error signal is amplified to drive the series pass elements and correct the output.

FILTERS:

Filters are RC or LC networks arranged as low pass devices to attenuate the varying component that remains when a-c voltage is rectified. In power supplies without subsequent active series regulators, the filters determine the amount of ripple that will remain in the d-c output. In supplies with active feedback series regulators, the regulator mainly controls the ripple with output filtering serving chiefly for phase-gain control as a lag element.

FLUX-O-TRAN:[®]

A registered trademark of Kepeo, Inc., applied to ferro-resonant voltage regulating transformers of a special design, which are used in many proprietary designs. The Flux-O-Tran, with its resonating capacitor provides a squarewave output (for high rectifier and filter efficiency) whose magnitude is largely independent of the primary voltage amplitude.

FREQUENCY RESPONSE:

The measure of an amplifier or power supply's ability to respond to a sinusoidal program. The frequency response measures the maximum frequency for full-output voltage excursion. This frequency is a function of the slewing rate and unity gain bandwidth.

FULL-WAVE RECTIFICATION:

In the rectifying process, full-wave rectification inverts the negative half-cycle of the input sinusoid so that the output contains two half-sine pulses for each input cycle. A pair of rectifiers arranged as shown with a centertapped transformer, or a bridge arrangement of four rectifiers and no centertap are both methods of obtaining full-wave rectification. (See Figure 6).

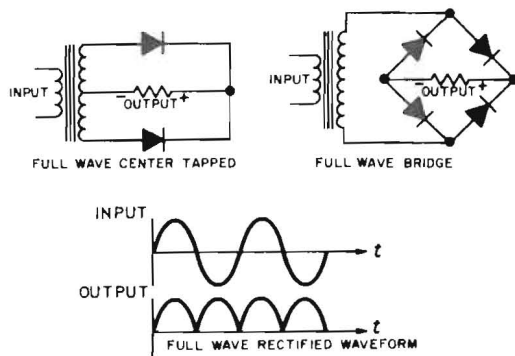

Figure 6: Full wave rectification.

HALF-WAVE RECTIFICATION:

In the rectifying process, half-wave rectification passes only one-half of each incoming sinusoid, and does not pass the opposite half-cycle. The output contains a single half-sine pulse for each input cycle. A single rectifier, arranged as in Figure 7, provides half-wave rectification. Because of its poorer efficiency and larger a-c component, half-wave rectification is usually employed in noncritical low current circumstances.

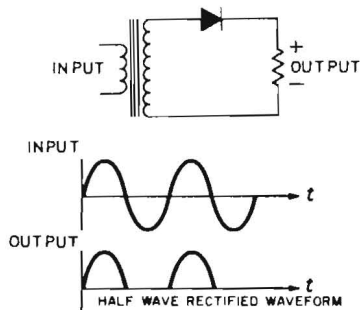

Figure 7: Half wave rectification.

HIGH SPEED REGULATOR:

A power supply regulator circuit which, by the elimination of its output capacitor, has been made capable of much higher slewing rates than are normally possible. High speed (HS) regulators are used where rapid step programming is needed, or as current regulators for which they are ideally suited. (See Slewing rate.)

HYBRID:

A combination of disparate elements to form a common circuit. In power supplies, the combination of vacuum tubes and transistors in the regulating circuitry.

INVERTING AMPLIFIER:

An amplifier whose output polarity is reversed as compared to its input. Such an amplifier obtains its negative feedback by a connection from output to input, and with high gain is widely used as an operational amplifier. An operational d-c power supply can also be described as a high gain inverting amplifier.

ISOLATION VOLTAGE:

A rating for a power supply which specified the amount of external voltage that can be connected between any output terminal and ground (the chassis). This rating is important when power supplies are connected in series.

LAG NETWORKS:

Resistance-reactive components, arranged to control phase-gain rolloff versus frequency. Used to assure the dynamic stability of a power supply's comparison amplifier. The main effect of a lag network is a reduction of gain at relatively low frequencies so that the slope of the remaining rolloff can be relatively more gentle.

LEAD NETWORKS:

Resistive-reactive components arranged to control phase-gain rolloff versus frequency. Used to assure the dynamic stability of a power supply's comparison amplifier. The main effect of a lead network is to introduce a phase lead at the higher frequencies, near the unity gain frequency.

LINEARITY, PROGRAMMING:

The linearity of a programming function refers to the correspondence between incremental changes in the input signal (resistance, voltage or current) and the consequent incremental changes in power supply output. Direct programming functions are inherently linear for the Kepeo Bridge regulator, and are accurate to within a percentage equal to the supply's regulating ability.

LINE REGULATION:

The maximum steady state amount that the output voltage or current will change as the result of a specified change in line voltage (usually for a step change between 105-125 or 210-250 volts, unless otherwise specified). Regulation is given either as a percentage of the output voltage or current, and/or as an absolute change, ΔE or ΔI .

LOAD REGULATION:

The maximum steady state amount that the output voltage or current will change as the result of a specified change in output load, generally from no-load to full-load unless otherwise specified. Regulation is given either as a percentage of the output voltage or current and/or as an absolute change, ΔE or ΔI .

LOOP (LEAKAGE) CURRENT:

A d-c current flowing in the feedback loop (voltage control) independent of the control current generated by the reference zener diode source and reference resistor. The loop (leakage) current remains when the reference current is made zero. It may be compensated for, or nulled in special applications to achieve a very high impedance (zero current) at the feedback (voltage control) terminals.

LOOP GAIN:

A measure of the feedback in a closed-loop system, being equal to the ratio of the open-loop to the closed-loop gains, in db, A-G. The magnitude of the loop gain determines the error attenuation and, therefore, the performance of an amplifier used as a voltage regulator. (See Open-loop and Closed-loop gain.)

MASTER-SLAVE OPERATION:

A system of interconnection of two regulated power supplies in which one, (the master), operates to control the other, (the slave). Specialized forms of

the master-slave configuration are used for: *Complementary Tracking* (plus and minus tracking around a common point); *Parallel Operation*, to obtain increased current output for voltage regulation; *Compliance Extension*, to obtain increased voltage output for current regulation.

MODULAR:

The term "modular" is used to describe a type of power supply designed to be built into other equipment, either chassis or rack mount. It is usually distinguished from laboratory bench equipment by a large choice of mounting configurations and by a lack of meters and controls.

MTBF Mean time between (or before) failure:

A measure of reliability giving either the time before first failure or, for repairable equipment, the average time between repairs. MTBF may be approximated or predicted by summing the reciprocal failure rates of individual components in an assembly.

NULL JUNCTION:

That point on the Kepco bridge at which the reference resistor, the voltage control resistance and one side of the comparison amplifier coincide. The null junction is maintained at almost zero potential and is a *virtual ground*. (See Summing Points).

OFFSET VOLTAGE:

A d-c potential remaining across the *comparison amplifier's* input terminals (from the null junction to the common terminal) when the output voltage is zero. The polarity of the offset voltage is such as to allow the output to pass through zero and the polarity to be reversed. It is often deliberately introduced into the design of power supplies to reach and even pass zero output volts.

OPEN-LOOP GAIN:

The gain, measured without feedback, is the ratio of the voltage appearing across the output terminal pair to the causative voltage required at the (input) null junction. The open-loop gain is denoted by the symbol A in diagrams and equations. (See Closed loop and Loop gain.)

OPERATIONAL POWER SUPPLY:

A power supply whose control amplifier has been optimized for signal processing applications rather than the supply of steady-state power to a load. A self-contained combination of operational amplifier, power amplifier and power supplies for higher level operation applications.

OPERATIONAL PROGRAMMING:

The process of controlling the output voltage of a regulated power supply by means of signals (which may be voltage, current, resistance or conductance) which are *operated on* by the power supply in a pre-determined fashion. Operations may include algebraic manipulations, multiplication, summing, integration, scaling and differentiation. (See Figure 8).

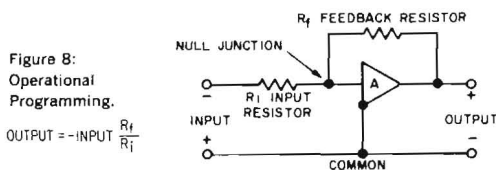

OUTPUT IMPEDANCE:

The effective dynamic output impedance of a power supply is derived from the ratio of the measured peak-to-peak change in output voltage to a meas-

ured peak-to-peak change in alternating load current. Output impedance is usually specified throughout the frequency range d-c-100 kc.

OVERSHOOT:

A transient rise beyond regulated output limits, occurring when the a-c power input is turned on or off, and for line or load step changes. (See Figures 9, 11a-b).

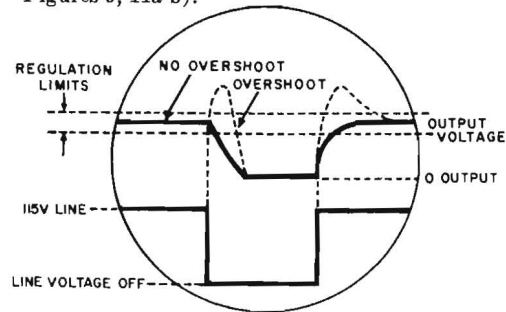

Figure 9: Scope view of turn-on/turn off effects on a power supply.

OVER-TEMPERATURE PROTECTION:

A thermal relay circuit which turns off the power automatically should an over-temperature condition occur.

PARALLEL OPERATION:

Voltage regulators, connected together so that their individual output currents are added and flow in a common load. Several methods for parallel connection are used: spoiler resistors, master/slave connection, parallel programming and parallel padding. Current regulators can be parallel without special precaution.

PARALLEL PADDING:

A method of parallel operation for two or more power supplies in which their current limiting or automatic crossover output characteristic is employed so that each supply regulates a portion of the total current, each parallel supply adding to the total and "padding" the output only when the load current demand exceeds the capability—or limit setting—of the first supply.

PARALLEL PROGRAMMING:

A method of parallel operation for two or more power supplies in which their feedback terminals (voltage control terminals) are also paralleled. These terminals are often connected to a separate programming source.

PASS ELEMENT:

A controlled variable resistance device, either a vacuum tube or power transistor, in series with the source of d-c power. The pass element is driven by the amplified error signal to increase its resistance when the output needs to be lowered or to decrease its resistance when the output must be raised. (See Series Regulator.)

POWER SUPPLY (ac to dc):

Generally, a device consisting of transformer, rectifier and filter for converting available a-c to a prescribed d-c voltage or current.

PROGRAMMING:

The control of any power supply functions, such as output voltage or current, by means of an external or remotely located variable control element. Control elements may be variable resistances, conductances, or variable voltage or current sources. (Figure 10).

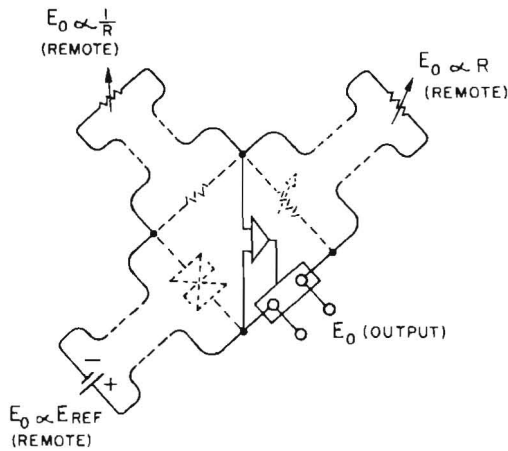

Figure 10: Remote programming connection.

PROGRAMMING SPEED:

Programming Speed describes the time required to change the output voltage of a power supply from one value to another. The output voltage must change across the load and because the supply's filter capacitor forms an RC network with the load and internal source resistance, programming speed can only be described as a function of load. Programming speed is the same as the "recovery time" specification for *current regulated* operation; it is not related to the recovery time specification for voltage regulated operation.

RECOVERY TIME (Current Regulation):

Specifies the time needed for the output current to return to a value within the regulation specification after a step load or line change. For load change, current will recover at a rate governed by the rate-of-change of the compliance voltage across the load. This is governed by the RC time constant of the output filter capacitance, internal source resistance and load resistance. (See Programming Speed).

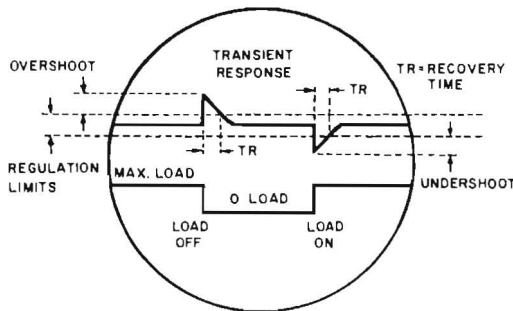

Figure 11a: Scope view shows the effects of a step load change.

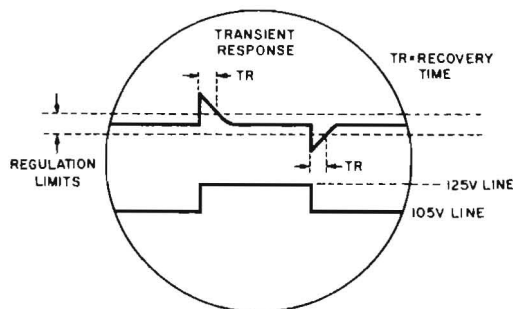

Figure 11b: Scope view shows the effects of a step line change.

RECOVERY TIME (Voltage Regulation):

Specifies the time needed for the output voltage to return to a value within the regulation specification after a step load or line change. Recovery time, rather than response time, is the more meaningful and therefore preferred way of specifying power supply performance, since it relates to the regulation specification. (Figures 11a-b).

REGULATED POWER SUPPLY:

A power supply which maintains a constant output voltage (or current) for changes in the line voltage, output load, ambient temperature or time.

REGULATION:

The maximum amount that the output will change as a result of the specified change in line voltage, output load, temperature or time. Line regulation, load regulation, stability, and temperature coefficient are defined and usually specified separately.

REMOTE ERROR SENSING:

A means by which the regulator circuit senses the voltage directly at the load. This connection is used to compensate for voltage drops in the connecting wires.

RESPONSE TIME (Time Constant):

Specifies the time required for the voltage or current excursion to be reduced to 37% of its peak value after a step load or line change. This is not the preferred way of specifying voltage regulator performance (See Recovery Time).

RESOLUTION:

The minimum voltage (or current) increment within which the power supply's output can be set using the panel controls. For continuous controls, the minimum increment is taken to be the voltage (or current) change caused by 1 degree of shaft rotation.

RIPPLE:

Stated either in peak-to-peak or in rms value, "ripple" specifies the maximum a-c component that appears in a d-c output. Unless specified separately, ripple includes unclassified noise.

SERIES OPERATION:

The output of two or more power supplies connected together to obtain a total output voltage equal to the sum of their individual voltages. Load current is equal and common through each supply. The extent of series connection is limited by the maximum specified potential rating between any output terminal and ground. (See Isolation Voltage). For series connection of current regulators, master/slave (compliance extension) or automatic crossover is used.

SERIES REGULATOR:

A device placed in series with a source of power that is capable of controlling the voltage or current output by automatically varying its series resistance. (See Pass Element).

SHORT CIRCUIT PROTECTION (Automatic):

Any automatic current limiting system which enables a power supply to continue operating at a limited current, and without damage, into any output overload including short circuits. The output voltage must be restored to normal when the overload is removed, as distinguished from a fuse or circuit-breaker system which opens at overload and must be closed to restore power. (See Current Limiting, Figure 5).

SHUNT REGULATOR:

A device placed across the output, which controls the current through a series dropping resistance to maintain a constant voltage or current output.

SLAVED TRACKING:

A system of interconnection of two or more regulated supplies in which one (the master) operates to control the others (the slaves). The output voltages of the slave units may be equal or proportional to the output voltage of the master unit. (The slaved output voltages track the master output voltage in a constant ratio.) (See Complementary Tracking and Master/Slave).

SLEWING RATE:

A measure of the programming speed or current-regulator response timing. The slewing rate measures the maximum rate-of-change of voltage across the output terminals of a power supply. Slewing rate is normally expressed in volts per second ($\Delta E/\Delta T$) and can be converted to a sinusoidal frequency-amplitude product by the equation $f(E_{pp}) = \text{slewing rate}/\pi$, where E_{pp} is the peak-to-peak sinusoidal volts. Slewing rate = $\pi f(E_{pp})$. (See High speed regulator).

SPOILER RESISTORS:

Resistors used to *spoil* the load regulation of regulated power supplies to permit parallel operation when not otherwise provided for.

STABILITY, LONG TERM (LTS):

The change in output voltage or current as a function of time, at constant line voltage, load and ambient temperature (sometimes referred to as drift).

STEP LINE VOLTAGE CHANGE:

An instantaneous change in line voltage (e.g., 105-125V a-c); for measuring line regulation and recovery time.

STEP LOAD CHANGE:

An instantaneous change in load current (e.g., zero to full load); for measuring the load regulation and recovery time.

SUMMING POINT:

(See Null junction). The null junction is called a summing point because, as the input to a high gain d-c amplifier, operational summing can be performed at this point. As a virtual ground, the summing point decouples all inputs so that they add linearly in the output, without other interaction. (See Operational programming.)

TEMPERATURE COEFFICIENT (TC):

The percent change in the output voltage or current as a result of a 1°C change in the ambient operating temperature (% per °C).

TEMPERATURE, OPERATING:

The range of environmental temperatures in which a power supply can be safely operated (typically, -20°C to +50°C). See Ambient Operating Temperature (Range).

TEMPERATURE, STORAGE:

The range of environmental temperatures in which a power supply can be safely stored (typically, -40°C to +85°C).

UNIPOLAR:

Having but one pole, polarity or direction. Applied to amplifiers or power supplies, it means that the output can vary in only one polarity from zero and, therefore, must always contain a d-c component. (See Bipolar.)

UNITY GAIN BANDWIDTH:

A measure of the gain-frequency product of an amplifier. Unity gain bandwidth is the frequency at which the *open-loop gain* becomes unity, based on a 6 db per octave crossing. (See Figure 12, Typical Gain-Frequency (Bode) Plot.)

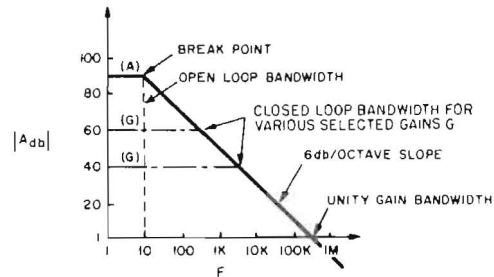

Figure 12: Gain-frequency (Bode) plot.

VIP:®

A model designation of Kepco, Inc., applied to a group of load protectors: (V) Voltage, (I) Current, (P) Protectors. The VIP devices provide overvoltage, undervoltage and over/under current sensing and protection circuits.

VIX,® INDICATORS:

Voltage/Current Crossover Indicators. VIX indicators are a pair of small mode lamps on the front panel of automatic crossover power supplies. One lamp lights during voltage regulated operation of the power supply; the other lamp lights during current regulated operation.

VIX SIGNAL:

A keyed voltage, whose polarity is an indication of power supply output voltage/current regulation mode. The polarity abruptly reverses at the crossover point and can be used to actuate external mechanisms such as lamps, alarms, etc.

VOLTAGE CORRECTOR:

An active source of regulated power placed in series with an unregulated supply to sense changes in the output voltage (or current); and to correct for these changes by automatically varying its own output in the opposite direction, thereby maintaining the total output voltage (or current) constant. (See Figure 13).

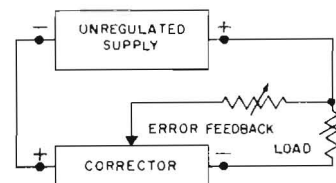

Figure 13: Circuit used to sense output voltage changes.

VOLTAGE REFERENCE:

A separate, highly regulated voltage source used as a standard to which the output of the power supply is continuously referred.

WARM-UP TIME:

The time (after power turn-on) required for the output voltage, or current to reach an equilibrium value within the stability specification.



APPLICATION NOTES

The effective use of a regulated power supply depends greatly on a clear understanding of its nature, capabilities and limitations. These notes seek to provide a basis for this understanding. For an expanded treatment, write for the *Kepeco Power Supply Handbook*.

MEASUREMENTS

To properly measure regulation, ripple, stability and other performance characteristics of precision DC power supplies, considerable care in the use of sensitive instrumentation is required. In particular, one must avoid introducing excessive errors through the way in which the instrumentation is connected. Of particular concern are the voltage drops which occur in the connections to the output terminals and in the wiring to the load. The resistance of connections and wires is often overlooked, yet even a few milliohms in a critical measuring path can introduce sufficient error as to render the measurement meaningless. Ordinary 4-terminal network theory is applicable and must be strictly followed. The important thing is to be certain that the measuring points are physically identical to the error sensing points. Detailed measurements procedures may be found in the "Kepeco Power Supply Handbook".

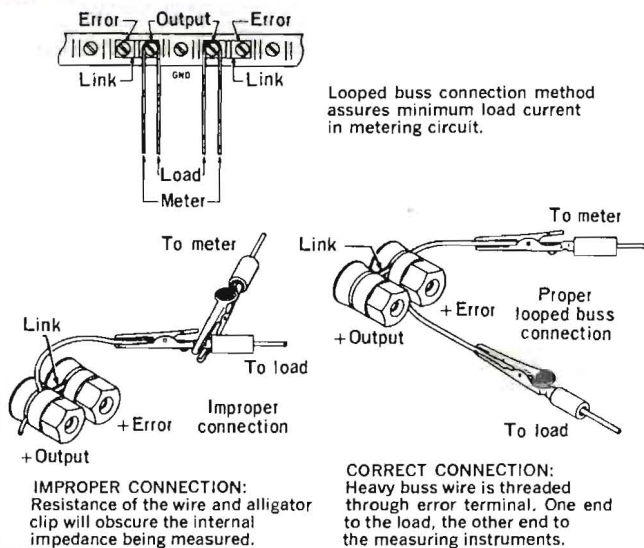

Remote error sensing is essential for all high precision applications of low-voltage, high-current power supplies. Remote error sensing permits the user to compensate for line drops (usually up to 0.5 volts per lead) so that the rated regulation performance of the power supply is obtained directly at the load.

THE MINIMUM "DELTA"

Many regulation specifications are expressed as a fixed percentage or minimum absolute change, whichever is greater. This form is required so that an accurate specification can be written on a *variable* parameter. A constant percentage specification would obviously rapidly require zero error as zero volts is approached; but, since the regulated power supply, like any feedback mechanism, requires a finite error signal to actuate the process of regulation, a minimum error must exist. This minimum error represents a measure of the power supply's resolution and sensitivity.

The minimum "delta" figure is used to determine the performance that can be expected whenever a power supply is used at less than its maximum output rating. The "minimum

delta" portion of any specification is as important as the rated percentage and must not be overlooked when comparing specifications.

DYNAMIC IMPEDANCE

The source impedance presented by a power supply to its load is a complex frequency-dependent number, consisting of an equivalent resistance determined by the Power Supply's regulation specification (a function of the comparison amplifier's gain), a reactive component dependent on the output filter capacitor and a reactive component which depends on the wiring inductance. The inductive component dominates the impedance at frequencies above 10 kc.

As the effective series inductance is specified, impedance can be easily computed for frequencies above 10 kc. This does not, of course, include the inductance of the load-connecting wires, which generally is very much larger than the specified internal inductance.

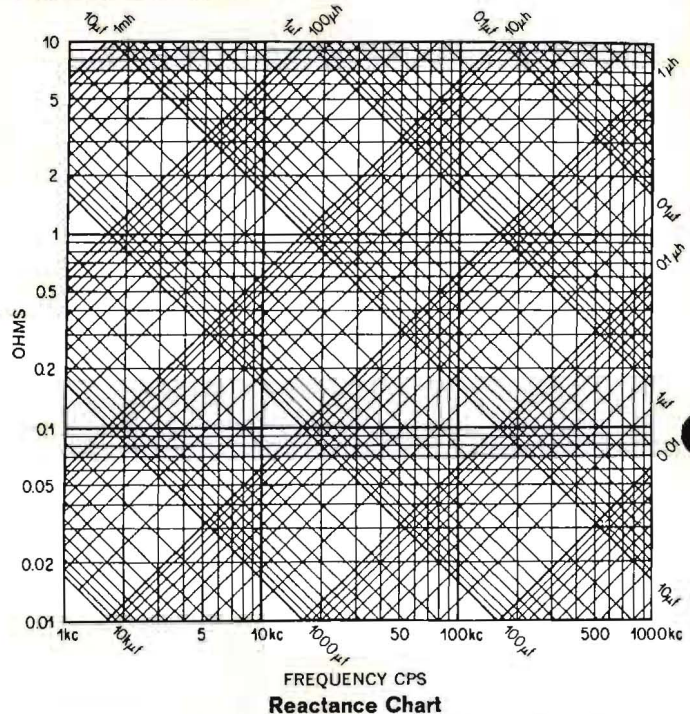

Since many circuits depend upon the decoupling effect of a power supply's low source impedance, the following procedures are recommended to minimize the effect of wiring inductance: load wires should be twisted together and should be of the heaviest possible gauge. Remote error sensing wires should also be twisted together, and, in addition, a capacitor bypass *directly at the load terminals* is very useful. Such a capacitor acts as a local energy source, compensating for the load wiring inductance. When particularly long sensing leads are used, it is sometimes helpful to connect local sensing bypass capacitors *at the power supply*. These would be placed between the individual plus and minus output terminal and their respective error sensing terminal. They serve to bypass the combination load-wire and sense-wire inductance and prevent transient instability.

OUTPUT VOLTAGE PROGRAMMING

The unique Kepeco comparison bridge circuit enables all Kepeco programmable power supplies to be externally controlled over their entire output voltage range. Provision is made for remote programming by means of external resistances, voltage sources, or inverse resistance programming. For detailed treatment of the programming feature, refer to the "Kepeco Power Supply Handbook".

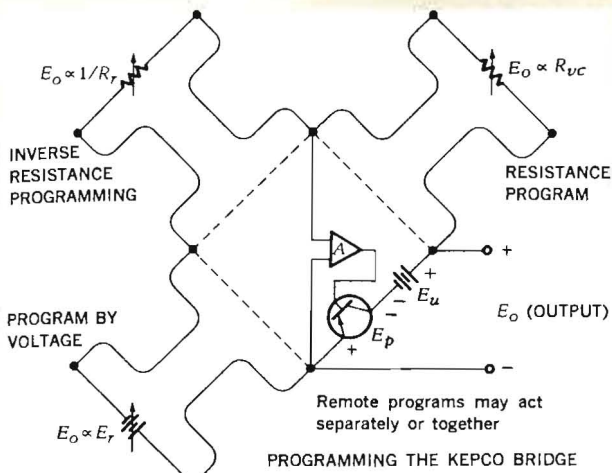

CONSTANT CURRENT OPERATION

Current control is achieved by sensing a small sample voltage developed across a resistor in series with the load. The power supply is controlled so as to maintain this sample voltage constant. In such operation, the voltage across the load changes in direct proportion to the load resistance, and is known as the voltage compliance.

Conventional sampling techniques for current regulation do not permit operation down to zero current. With the fixed sensing resistor used for internal current sampling, for example, a lower current limit is imposed by the vanishingly small sample voltage as current approaches zero. When an external sensing resistor is employed, and the resistance can be increased to compensate for the vanishing current, the lower current limit is then imposed by the power supply's own control bridge current. This current circulates counter to the normal direction of output current and so opposes the voltage drop in the sensing resistor. When the output current equals the bridge current; the two cancel, and the sampling signal approaches zero.

It is possible to circumvent these limits and control very small currents by using a separate auxiliary power supply in one of several possible circuits, detailed in the Kepco Power Supply Handbook.

AUTOMATIC CROSSOVER

Kepco CK, KS and KO models incorporate two regulator bridge circuits and a unique gate which automatically switches the mode of operation between them from constant voltage to constant current, depending on the relative settings of the voltage and current controls and on the load resistance. This feature is called "Automatic Crossover".

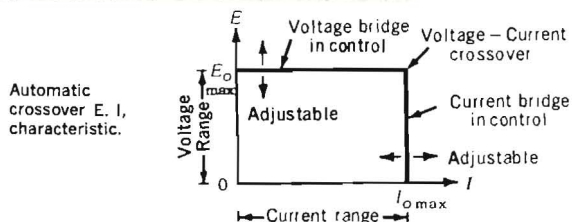

Power supplies with the automatic crossover feature can be remotely controlled in either or both modes by means of remote resistances or voltage sources, or they can be inversely resistance programmed (see Output Voltage Programming). These models can also be operated in the constant current mode using an external sensing resistor. When employing "external sensing", current control is achieved with an external programming resistance or voltage source. The Kepco ABC, PAX, PBX, OPS and HB models can be operated in the constant current mode using external sensing and programming only.

The external current sensing resistor carries the full load

current and in all-transistor models is selected to drop 1 volt at the operating current. For HB models, and the hybrid units in the ABC design group, the sensing resistor is selected to drop 10 volts at the operating current. This resistor should have a low temperature coefficient and should be conservatively rated for power dissipation. At least a ten times derating factor is recommended. The current control rheostat, used to vary the current, carries only the control bridge current of the power supply, either 1 ma or 10 ma as the case may be. This current control can be used to vary the output current (for a fixed sensing resistor) over as much as a 10:1 ratio.

PROGRAMMING SPEED

The programming speed (or recovery time for current regulated operation) cannot, strictly, be specified independently for a power supply. These two parameters are identical and are functionally dependent on the RC time constant that the load resistance makes with the output filter capacitor. In addition, the current mode recovery time is modified by the charging time of the output capacitor, a linear function of the current setting.

In general, when the power supply is lightly loaded, the output capacitor can be charged rapidly but discharges more slowly. For heavy loading, the contrary situation prevails with a slow charging time but relatively rapid discharge. At approximately 50% loading, the charging and discharging speeds are equal and for most supplies equals about 250 volts per second, which corresponds to the maximum programming speed.

In current mode, the recovery time can also be expressed in volts per second, dv/dt , since the recovery time is the time that it takes for the voltage to change from one steady value to another. A falling voltage follows the exponential decay of the filter capacitor through the remaining load resistance. For purposes of calculation, the equivalent output capacitance can be taken as approximately $C_{Eq} = I_o/250$, where I_o equals the current rating of the power supply. A rising voltage also follows an exponential except that it is additionally limited by the capacitor charging rate of the current control setting. This can be determined by the ratio of the current setting I_s to the power supply's current rating I_o . The rate of increasing voltage change, $dv/dt = (250) (I_s/I_o)$. Once the rate dv/dt has been approximated, the recovery time is easily computed for any selected voltage compliance swing.

Operational power supplies (OPS series) and the PAX-HS Modules, having no output capacitor, are capable of very fast voltage slewing and therefore are ideal for rapid programming or current regulator applications.

AMPLIFIERS

Programmable bridge regulated power supplies can be operationally controlled as a high gain, DC amplifier functioning as an inverting amplifier, impedance transformer, summing and many similar circuit configurations. The Kepco Power Supply Handbook provides detailed circuit information.

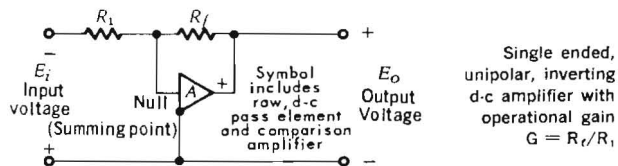

REMOTE VIX® SIGNALLING

VIX equipped power supplies are provided with a pair of rear panel pin jacks which make available the mode indicating signal for external use. The mode indicating voltage is a two-condition, ± 8 volt polarity reversal which occurs abruptly at the crossover point. The VIX control signal delivers up to 0.8 milliamperes, which is adequate to activate a sensitive relay through a single transistor amplifier. Model VIX-1C is available as an accessory to actuate an SPDT relay on VIX command.



General Offices and Plant: KEPCO, INC. • 131-38 SANFORD AVENUE • FLUSHING, N.Y. 11352

Phone: (212) 461-7000 • TWX #212-539-6623 • Cable: KEPCOPOWER NEWYORK

SALES REPRESENTATIVES

- 1 **N. Y. METROPOLITAN AREA and Northern New Jersey**
EASTERN INSTRUMENTATION, INC.
350 Northern Blvd., Great Neck, N.Y. 11021
N.Y. Phone: (516) 466-9505
N.J. Phone: (201) 779-1234
- 2 **TRUMBULL, CONNECTICUT**
RAY PERRON & COMPANY, INC.
36 Louis Street, Trumbull, Conn. 06611
(203) AM 8-9631
- 3 **FARMINGTON, CONNECTICUT**
RAY PERRON & COMPANY, INC.
10 Briarwood Road, Farmington, Conn. 06032
(203) OR 7-9025
- 3 **BOSTON, MASSACHUSETTS**
RAY PERRON & COMPANY, INC.
1870 Centre Street, Boston, Mass. 02132
(617) FA 3-1008 — TWX #617-325-8627
- 4 **MANCHESTER, NEW HAMPSHIRE**
RAY PERRON & COMPANY, INC.
19 Caron Road - Bedford RFD #2
Manchester, N.H. 03102
(603) 472-4091
- 5 **UTICA, NEW YORK**
NACO ELECTRONICS CORP.
2631 Edgewood Road, Utica, N.Y. 13501
(315) RE 2-1801
- 6 **SYRACUSE, NEW YORK**
NACO ELECTRONICS CORP.
119 Luther Avenue, Liverpool, N.Y. 13088
(315) GR 4-7481 — TWX #710-541-0439
- 7 **POUGHKEEPSIE, NEW YORK**
NACO ELECTRONICS CORP.
14 Lori Street, Poughkeepsie, N.Y. 12603
(914) 462-2730
- 8 **ROCHESTER, NEW YORK**
NACO ELECTRONICS CORP.
74 Park Avenue, Rochester, N.Y. 14450
(716) GR 3-4169
- 9 **PHILADELPHIA, PENNA.**
EASTERN INSTRUMENTATION INC.
613 Cheltenham Avenue, Philadelphia, Pa. 19126
(215) WA 7-6269
- 10 **WASHINGTON, D. C.**
LEE ASSOCIATES, INC.
12250 Wilkins Avenue, Rockville, Md. 20852
(301) 949-4800 — TWX #301-949-6786
- 11 **WINSTON SALEM, N. C.**
LEE ASSOCIATES, INC.
P.O. Box 906, Winston Salem, N.C. 27101
(919) 724-2406
- 12 **ORLANDO, FLORIDA**
LEE ASSOCIATES, INC.
P.O. Box 7896, Orlando, Fla. 32804
(305) 241-4445 — TWX #305-841-2356
- 13 **HUNTSVILLE, ALABAMA**
LEE ASSOCIATES, INC.
P.O. Box 1506, Huntsville, Ala. 35807
(205) 539-0761—TWX #205-533-2066
- 14 **CINCINNATI, OHIO**
THE SATULLO COMPANY
618 Cincinnati-Batavia Pike, Cincinnati, Ohio 45244
(513) 752-6683
In Dayton: Call Enterprise 6683
- 15 **CLEVELAND, OHIO**
THE SATULLO COMPANY
16801 Euclid Avenue, Cleveland, Ohio 44112
(216) IV 6-2800
In Pittsburgh: Call (412) 931-5200
- 16 **DETROIT, MICHIGAN**
THE SATULLO COMPANY
4514 N. Woodward Ave., Royal Oak, Mich. 48072
(313) LI 9-3910

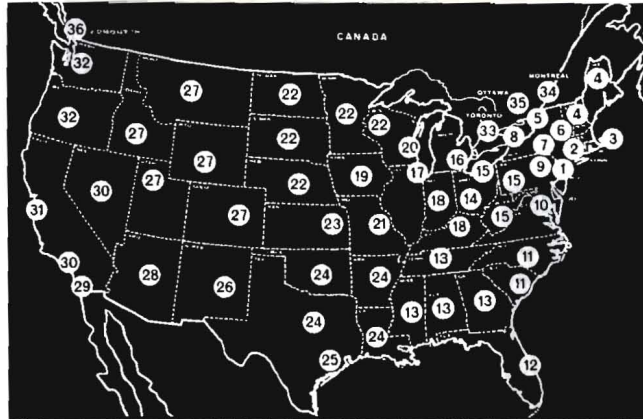

- 17 **CHICAGO, ILLINOIS**
MIDWEST ELECTRONIC SALES
5707 W. Division St., Chicago, Ill. 60651
(312) 626-0030 — TWX #312 265-1415
- 18 **INDIANAPOLIS, INDIANA**
MIDWEST ELECTRONIC SALES
5462 E. 40th St., Indianapolis, Ind. 46226
(317) LI 7-3259
- 19 **CEDAR RAPIDS, IOWA**
MIDWEST ELECTRONIC SALES
2042 Franklin Ave., N.E., Cedar Rapids, Iowa 52402
(319) 362-4410
- 20 **MILWAUKEE, WISCONSIN**
MIDWEST ELECTRONIC SALES
1317 Garfield Ave., Waukesha, Wisc. 53186
(414) 542-5129
- 21 **ST. LOUIS, MISSOURI**
NORMAN W. KATHRINUS & COMPANY
2427 Brentwood Blvd., St. Louis, Mo. 63144
(314) WO 2-5627
- 22 **MINNEAPOLIS, MINNESOTA**
E. C. ELECTRONIC SALES
10108 Abbott Ave., So., Minneapolis, Minn. 55431
(612) 888-4626 — TWX #612-292-4195
- 23 **KANSAS CITY, KANSAS**
NORMAN W. KATHRINUS & COMPANY
2336 So. Boeke St., Kansas City, Kan. 66103
(913) AD 6-4108
- 24 **DALLAS, TEXAS**
AIREP ENGINEERING COMPANY
P.O. Box 9555, Dallas, Texas 75214
(214) TA 4-3800
- 25 **HOUSTON, TEXAS**
AIREP ENGINEERING COMPANY
P.O. Box 36211, Houston, Texas 77036
(713) 774-2260
- 26 **ALBUQUERQUE, NEW MEXICO**
P. L. S. ASSOCIATES
9611 Acoma Rd., S.E. Albuquerque, N.M. 87112
(505) 298-5589 — TWX #505-243-8409
- 27 **DENVER, COLORADO**
P. L. S. ASSOCIATES
7895 East Prentice Ave., Englewood, Colo. 80110
(303) 771-0140 — TWX #303-771-2236
- 28 **PHOENIX, ARIZONA**
V. T. RUPP COMPANY
3707 West Ruth, Phoenix, Arizona 85021
(602) 939-8895
- 29 **SAN DIEGO, CALIFORNIA**
V. T. RUPP COMPANY
3445 Fifth Avenue, San Diego, Cal. 92103
(714) CY 8-9835 — TWX #714-291-0736

- 30 **LOS ANGELES, CALIFORNIA**
V. T. RUPP COMPANY
307 Parkman Avenue, Los Angeles, Cal. 90022
(213) DU 7-8224 — TWX #213-380-8840
- 31 **SAN FRANCISCO, CALIFORNIA**
V. T. RUPP COMPANY
1182 Los Altos Avenue, Los Altos, Cal. 94022
(415) 948-1483 — TWX #415-949-7950
- 32 **SEATTLE, WASHINGTON**
HARRY LEVINSON COMPANY
1211 East Denny Way, Seattle, Wash. 98122
(206) EA 3-5100 — TWX #206-998-1047

IN CANADA

- 33 **TORONTO, CANADA**
ATLAS INSTRUMENT CORPORATION
Division of Atlas Electronics Limited
50 Wingold Avenue, Toronto 19, Canada
(416) RU 1-6174 — Telex 02-2319
- 34 **MONTREAL, QUEBEC**
ATLAS INSTRUMENT CORPORATION
Division of Atlas Electronics Limited
3333 Cavendish Blvd., Montreal, Quebec
(514) HU 9-8495 — Telex 01-2141
- 35 **OTTAWA, ONTARIO**
ATLAS INSTRUMENT CORPORATION
Division of Atlas Electronics Limited
342½ Elgin Street, Ottawa, Ontario
(613) CE 3-9471
- 36 **EDMONTON, ALBERTA**
ATLAS INSTRUMENT CORPORATION
17-10224 119th Street, Edmonton, Alberta
(403) 482-1371

OVERSEAS OFFICES

- GREAT BRITAIN**
AD. AURIEMA, LTD.
Impectron House, 125 Gunnersbury Lane
Acton, London W.3, England
Tel. ACorn 8762, Cable: AIREMA LONDON
Telex: 25864
- BELGIUM, LUXEMBOURG, and the NETHERLANDS**
AD AURIEMA — EUROPE S.A.
172a Rue Brogniez, Brussels 7, Belgium
Tel: 22-28-35, Cable: ADAURI BRUSSELS
Telex: 21646
- FRANCE**
AD. AURIEMA — FRANCE, S.A.R.L.
243 bis, Boulevard Pereire, Paris 17, France
Tel: ETOile 12-49 or 15-51, Cable: ADAURIE
- GERMANY, AUSTRIA & SWITZERLAND**
AD. AURIEMA — EUROPE, S.A.
Fleiner Strasse 17
7100 Heilbronn (Neckar), West Germany
Tel: (07131) 8-23-24, Telex: 728639
Cable: AURIEMA HEILBRONN
- ITALY**
AD. AURIEMA, INC.
Via Ferdinando di Savoia 2
Milan, Italy
Tel: 653, 106 Cable: FERCO MILAN
- FOR OTHER FOREIGN COUNTRIES CONTACT:**
AD. AURIEMA, INC.
85 Broad Street, New York, N.Y. 10004
Tel: (212) BO 9-7750, Cable: AURIEMA, NEWYK
Telex: RCA N.Y. 2791, TWX #710-581-3864