



USER MANUAL

Elo Touch Solutions PayPoint Android™ Rev. B



No part of this publication may be reproduced, transmitted, transcribed, stored in a retrieval system, or translated into any language or computer language, in any form or by any means, including, but not limited to, electronic, magnetic, optical, chemical, manual, or otherwise without prior written permission of Elo Touch Solutions, Inc.

Disclaimer

The information in this document is subject to change without notice. Elo Touch Solutions, Inc. and its Affiliates (collectively "Elo") makes no representations or warranties with respect to the contents herein, and specifically disclaims any implied warranties of merchantability or fitness for a particular purpose. Elo reserves the right to

Revise this publication and to make changes from time to time in the content hereof without obligation of Elo to notify any person of such revisions or changes.

Trademark Acknowledgments

AccuTouch, CarrollTouch, Elo, Elo (logo), Elo Touch, Elo Touch Solutions, Elo TouchSystems, IntelliTouch, iTouch, SecureTouch, TouchTools and VuPoint are trademarks of Elo and its Affiliates. Windows is a trademark of Microsoft Corporation.

Android is a trademark of Google LLC.

Table of Contents

Section 1: Introduction 4

Section 2: Unpacking and Operation 5

Section 3: Technical Support and Maintenance **Error! Bookmark not defined.**

Section 4: Safety 11

Section 5: Warranty Information **Error! Bookmark not defined.**

Section 1: Introduction

Product Description

The Elo PayPoint register is an all-in-one Android based cash register that comes equipped with built-in receipt printer, magnetic stripe reader, barcode reader, cash drawer, and customer facing display. In addition to its built-in peripherals, the system has a USB port that allows for connectivity of external USB devices.

Precautions

Follow all warnings, precautions and maintenance as recommended in this user manual to maximize the life of your unit and prevent risks to user safety. See Section 6 for more information on safety.

This manual contains information that is important for the proper setup of the scanner. Before setting up and powering on your new scanner, read through this manual, especially the Installation, configuration, and Operation chapters.

Section 2: PayPoint Unpacking and Operation

Box Contents

Verify that the box contains:

- PayPoint Android Unit
- Quick Install Guide
- PayPoint Power Cable (color should match PayPoint unit)
- 2 receipt paper rolls
- 2 cash drawer keys

Elo PayPoint Register Layout

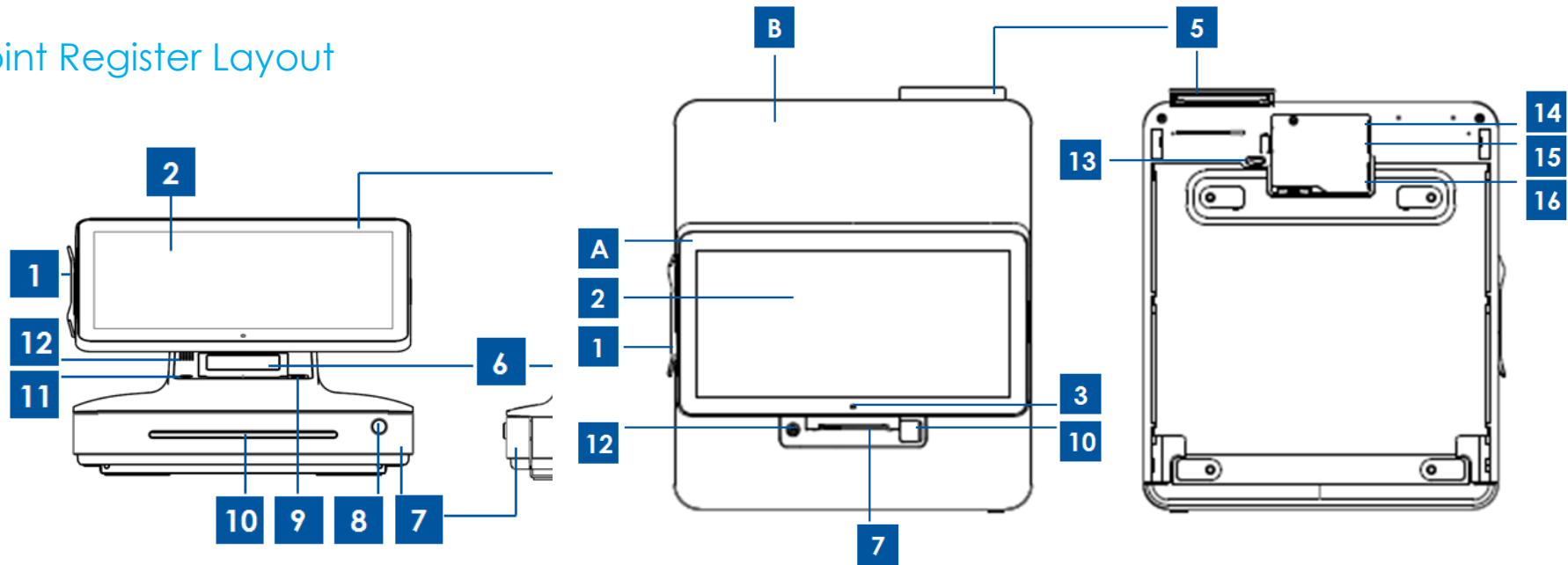

A. Register Display Head			
1	MSR	2	Main Display
3	Barcode Scanner		
B. Register Base			
4	Customer Facing Display	5	USB 2.0 Port
6	Receipt Printer	7	Cash Drawer
8	Cash Drawer Lock	9	Printer door release button
10	Check/Media Slot	11	Receipt Printer
12	Speaker	13	Cash Drawer Release
14	Ethernet Port	15	Mini USB 2.0 Port
16	Power Port	-	-

Register Display Head

The Elo PayPoint Register display head can be flipped to allow customers to complete purchase transactions by self-swiping payment cards, and to authorize transactions by signing directly onto the touchscreen.

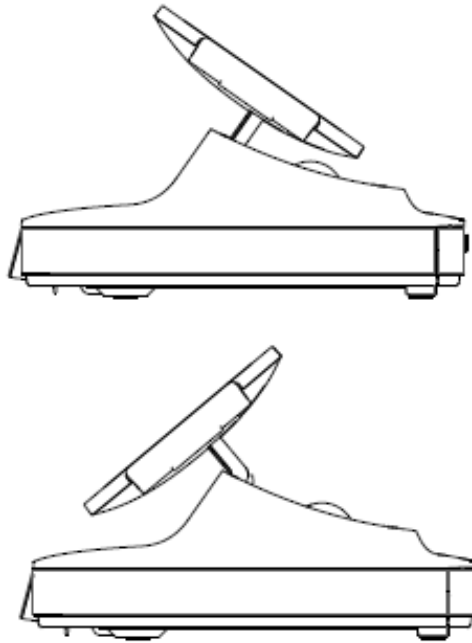

Figure 3. Elo PayPoint display head can be flipped and supports two configurations: Elo PayPoint Register cashier-facing view (top) and customer-facing view (bottom)

1. Magnetic Stripe Reader (MSR)

The register has a built in encryptable magnetic stripe reader. Application provider is responsible for correctly encrypting the reader.

When the register is in clerk view, the MSR will be on the left of the register display head. When register is in customer view, the MSR will be on the right of the register display head.

2. Touchscreen

The Elo PayPoint Register is equipped with a multi-touch touchscreen.

4. Barcode scanner

The register has a built in barcode scanner that scans 1-D barcodes. When the register is in cashier view, the barcode scanner will be on the right of the register display head.

5. Customer-facing display

The register base is equipped with a customer-facing display. As a cashier rings up customer orders, the customer facing display will display each order.

6. USB port (USB 2.0)

This USB port can be used to charge your mobile device.

Note: In order to comply with PCI compliance and to prevent security breaches, this USB port will not be accessible for connecting the register with other USB devices (e.g. mouse, keyboard, storage device)

7. Receipt printer (built-in)

The register is equipped with a built-in receipt printer that is located on the register base.

8. Cash drawer

The register is equipped with a cash drawer for storing cash, coins, and checks.

9. Cash drawer lock

Use the key that comes with the Elo PayPoint Register to lock / unlock the cash register. When cash drawer is locked, cash drawer will not open even when it is commanded to.

10. Printer head release button

Press this release button to release the printer head cover. For more information on how to change printer paper on the register, refer to the "Printer Maintenance" section of Chapter 8.

11. Check compartment slot

The cash drawer is designed with a slot for slipping checks into the cash drawer.

12. Printer Feed Button

Press the printer feed button to feed paper through the PayPoint Printer

13. Speaker (built-in)

The register is equipped with a built-in speaker.

14. Cash drawer manual release latch

A latch located on the bottom of the register base can be used to manually open the cash drawer.

15. USB port

This USB port can be used to charge your mobile device.

Note: In order to comply with PCI compliance and to prevent security breaches, this USB port will not be accessible for connecting the register with other USB devices.

16. Ethernet (LAN) port

Use this port to connect the register to a network via an Ethernet RJ-45 cable.

17. Power port

To power the register, plug one end of the power cable to the register power port, and the other end to the wall.

Power

Press the register power button to turn the Elo PayPoint Register on. Press and hold power button when the register is on to bring up the Shut Down option screen.

In the event that the register freezes and does not respond, press and hold the power button until the register turns off. If the register does not turn off via the power button, the register will need to be powered down by unplugging the power cord from the wall.

The Elo PayPoint Register power button is equipped with an LED that indicates the power status of the register, as follows:

Register Power Status	LED Status
OFF (disconnected from wall)	Off
OFF (connected to wall)	Red
SLEEP	Red
ON	White

The system consumes low power when in SLEEP and OFF modes. For detailed power consumption specifications, refer to technical specifications available on the Elo website www.elotouch.com.

To bring register out of sleep/standby mode, press the power button once.

If long periods of non-use are planned, turn off the Elo PayPoint Register to save power.

The maximum voltage, frequency and current for the register, are provided in the power ratings table below:

	Operating Voltage Range	Operating Frequency Range	Operating Current Range
Elo PayPoint Register	100 - 240Vac	50 – 60 Hz	0.1 – 0.3 Aac

Section 3: Technical Support and Maintenance

Information and guidance on how to use and operate your Elo PayPoint Register are available in this User Manual.

Solutions to Common Problems

Problem	Suggested Troubleshooting
The Elo PayPoint Register does not respond when turning on the system.	<p>Check that the power cable is properly connected to both the register and the wall. Power button LED will be red when register is properly connected to the wall.</p> <p>OR</p> <p>Unplug the power cable, re-plug after five seconds, and press the power button to turn on the system.</p> <p>OR</p> <p>In the case that the power button LED displays solid white light, which suggests that the system is on, there may be an issue with the display or LCD backlight. Please contact Elo Customer Service.</p>
Blank screen	<p>If the power button LED is blinking, the register may be in SLEEP mode. Press the power button to bring the unit out of SLEEP mode.</p>

<p>Receipt printer does not print text on the receipt paper</p>	<p>Ensure that the thermal receipt paper is installed in the printer in the proper orientation.</p> <p>Note: Only one side of the thermal paper is coated with the dye that changes color when heated. This is the side that will need to contact the printer thermal head.</p> <p>Refer to Chapter 8 for more information on how to properly install the thermal receipt paper in the receipt printer.</p> <p>OR</p> <p>Try and restart the register.</p>
<p>Poor receipt printing quality</p>	<p>Poor receipt printing quality may be due to the use of poor quality thermal paper. Refer to Chapter 8 for more information on recommended thermal paper for the Elo PayPoint Register receipt printer.</p>
<p>Receipt printer does not run when it's supposed to</p>	<p>Push the receipt head release button, lift receipt printer head cover, and check that there is no paper jam. Clear any paper jam.</p>
<p>MSR does not read card properly</p>	<p>The MSR may not function properly when dirty. Use MSR cleaning cards (purchasable in some office supply stores).</p>
<p>Cash drawer doesn't open</p>	<p>Check to ensure that cash drawer lock is not in lock position.</p> <p>OR</p> <p>Use the cash drawer manual release latch to open drawer.</p>

Technical Assistance

Technical Specifications

visit www.elotouch.com/products
for technical specifications for this device

Online Self-Help

visit www.elotouch.com/go/websupport
for online self-help

Technical Support

visit www.elotouch.com/go/contactsupport
for technical support

See this user manual's last page for worldwide technical support phone numbers.

Elo PayPoint Register Care and Handling

The following tips will help maintain optimal performance of your Elo PayPoint Register:

- Disconnect the power cable before cleaning.
- To clean the unit (except for touch screen), use a soft cotton or microfiber cloth lightly dampened with a mild detergent.
- It is important that your unit remains dry. Do not get liquids on or inside the unit. In the event that liquid does get inside, have a qualified service technician inspect the unit before you power it on again.
- Do not wipe the screen with a cloth or sponge that could scratch the surface.
- When cleaning the touchscreen, use window or glass cleaner applied to a clean cloth. Never apply the cleaner directly on the touchscreen. Do not use alcohol (methyl, ethyl or isopropyl), thinner, benzene, or other abrasive cleaners.

Printer Maintenance

Changing Printer Paper

The register receipt printer operates using heat, and not with ink. Printer paper compatible with the Elo PayPoint receipt printer are as follows:

Type: Thermal Paper (2 ¼ inches x 80 feet)

Paper width: 2 ¼ inches (58 mm)

Paper roll diameter: 1 7/8 inches (50 mm) (maximum)

Paper length: 80 feet (24.4 m)

Printing width: 48mm

To change the paper for the Elo PayPoint Register receipt printer:

1. Ensure that the register display head is flipped away from the receipt printer (in customer-facing view).
2. Push the receipt printer head release button to release the printer head cover.
3. Lift printer head cover.

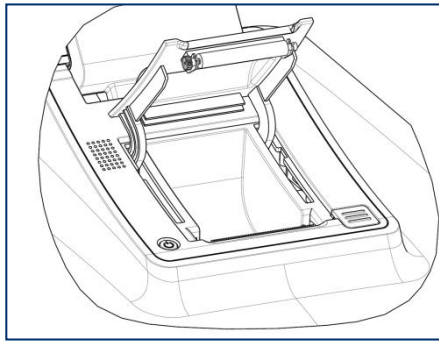

4. Take out the roll of used printer paper, and replace with new roll of printer paper. Make sure that the paper is placed and positioned in the correct orientation, as shown below.

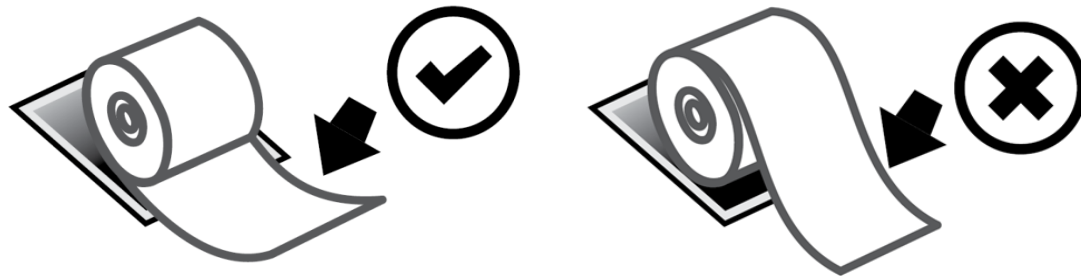

Cleaning and Care of Printer

The following tips will help maintain optimal performance of your Elo PayPoint Register receipt printer:

- Do not pull any paper that is ejected from the printer.
- Do not touch the printer roller or thermal head surface with bare hands. In the case of contact between printer roller or thermal head and hands, clean the roller and/or thermal head surface with alcohol, as specified in the latter parts of this section herein.

Note: Contaminating heating elements with any oil or grease (e.g. oil from hands) may shorten the life of the thermal head.

- Do not print when there is no receipt printer installed in the printer.

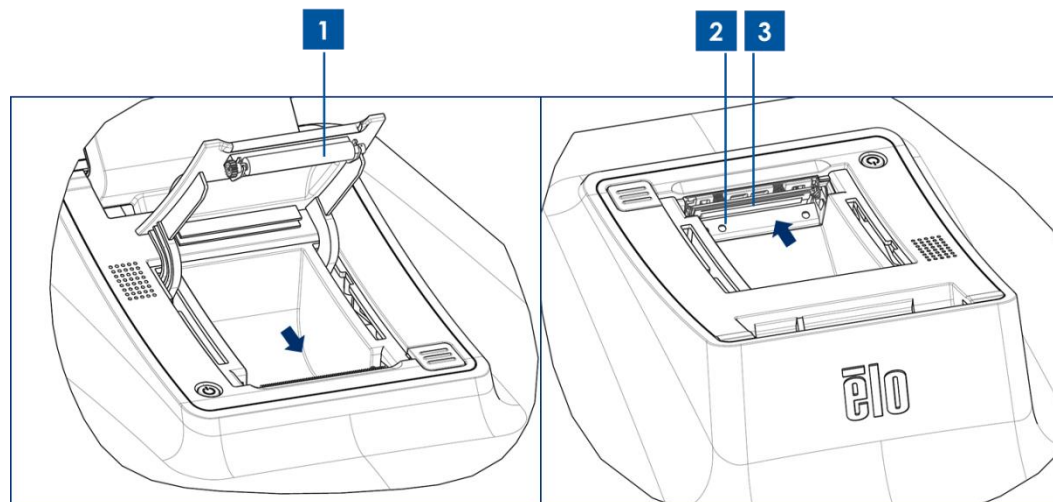

Figure 4. View of receipt printer when printer head cover is open (left). View of the receipt printer according to the view denoted by the arrow.

Prior to cleaning the PayPoint Register receipt printer, ensure that the register display head is flipped away from the receipt printer (in customer-facing view). Push the receipt printer head release button to release printer head cover and access the different printer components listed in Figure 4 above. Guidance on how to clean the printer photo-sensor, thermal head, and roller are as follows:

1. Roller

It is recommendable to clean the printer roller once a month. To do so:

- a. Apply isopropyl alcohol onto a cloth.
- b. Wipe off any stain from the printer roller with the alcohol dampened cloth.
- c. Use a dry soft cloth to wipe the roller.
- d. Wait to allow the roller to dry off, and then shut the printer head cover.

2. Photo-sensor:

It is recommendable to clean the printer photo-sensor once a month. To do so:

- a. Use a Nylon brush (or equivalent) to brush off any paper dust or other residues that may be on the photo-sensor.

3. Thermal head

It is recommendable to clean the printer thermal head once a month. To do so:

- a. Moist cotton swab with isopropyl alcohol.
- b. Wipe the thermal head with the cotton swab to remove any stain from the thermal head.
- c. Use a dry soft cloth to wipe the thermal head.
- d. Wait to allow the thermal head to dry off, and then shut the printer head cover.

Section 4: Safety

Waste Electrical & Electronic Equipment Directive (WEEE)



This product should not be disposed of with household waste. It should be deposited at a facility that enables recovery and recycling.

- Elo has put in place recycling arrangements in certain parts of the world. For information on how you can access these arrangements, please visit www.elotouch.com/e-waste-recycling-program/.

Section 7: Regulatory Information

Electrical Safety Information

Compliance is required with respect to the voltage, frequency, and current requirements indicated on the manufacturer's label. Connection to a different power source than those specified herein will likely result in improper operation, damage to the equipment or pose a fire hazard if the limitations are not followed.

There are no operator serviceable parts inside this equipment. There are hazardous voltages generated by this equipment which constitute a safety hazard. Service should be provided only by a qualified service technician.

Contact a qualified electrician or the manufacturer if there are questions about the installation prior to connecting the equipment to mains power.

Emissions and Immunity Information

Notice to Users in the United States: This equipment has been tested and found to comply with the limits for a Class A digital device, pursuant to Part 15 of FCC Rules. These limits are designed to provide reasonable protection against harmful interference in a residential installation. This equipment generates, uses, and can radiate radio frequency energy, and if not installed and used in accordance with the instructions, may cause harmful interference to radio communications.

Notice to Users in Canada: This equipment complies with the Class A limits for radio noise emissions from digital apparatus as established by the Radio Interference Regulations of Industrial Canada.

Notice to Users in the European Union: Use only the provided power cords and interconnecting cabling provided with the equipment. Substitution of provided cords and cabling may compromise electrical safety or CE Mark Certification for emissions or immunity as required by the following standards:

This Information Technology Equipment (ITE) is required to have a CE Mark on the Manufacturer's label which means that the equipment has been tested to the following Directives and Standards: This

equipment has been tested to the requirements for the CE Mark as required by EMC Directive 2014/30/EU as indicated in European Standard EN 55032 Class A and the Low Voltage Directive 2014/35/EU as indicated in European Standard EN 60950-1.

General Information to all Users: This equipment generates, uses and can radiate radio frequency energy. If not installed and used according to this manual the equipment may cause interference with radio and television communications. There is, however, no guarantee that interference will not occur in any particular installation due to site-specific factors.

1. In order to meet emission and immunity requirements, the user must observe the following:
 - a. Use only the provided I/O cables to connect this digital device with any computer.
 - b. To ensure compliance, use only the provided manufacturer's approved line cord.
 - c. The user is cautioned that changes or modifications to the equipment not expressly approved by the party responsible for compliance could void the user's authority to operate the equipment.

2. If this equipment appears to cause interference with radio or television reception, or any other device:
 - a. Verify as an emission source by turning the equipment off and on. If you determine that this equipment is causing the interference, try to correct the interference by using one or more of the following measures:
 - i. Move the digital device away from the affected receiver.
 - ii. Reposition (turn) the digital device with respect to the affected receiver.
 - iii. Reorient the affected receiver's antenna.
 - iv. Plug the digital device into a different AC outlet so the digital device and the receiver are on different branch circuits.
 - v. Disconnect and remove any I/O cables that the digital device does not use. (Unterminated I/O cables are a potential source of high RF emission levels.)
 - vi. Plug the digital device into only a grounded outlet receptacle. Do not use AC adapter plugs. (Removing or cutting the line cord ground may increase RF emission levels and may also present a lethal shock hazard to the user.)

If you need additional help, consult your dealer, manufacturer, or an experienced radio or television technician.

Agency Certifications

The following certifications and marks have been issued or declared for this peripheral:

- FCC/IC
- CE
- UL/cUL/CB
- China CCC
- China SRRC
- 5150-5350MHz for indoor use
- 5470-5725 for indoor/outdoor use

RED:

- Hereby, Elo declares that the radio equipment type, PayPoint, is in compliance with Directive 2014/53/EU.
- The full text of the EU declaration of conformity is available at the following internet address: www.elotouch.com

Explanation of Markings

In accordance with the SJ/T11364 requirement, electrical and electronic products are marked with the following pollution control logo.

The Environment-Friendly Use Period for this product is 10 years. The product will not leak or mutate under normal operating conditions listed below, so that the use of this electronic information product will not result in any severe environmental pollution, any bodily injury, or damage to any assets.



Operating Temperature: See chart below

Storage Temperature: See chart below

It is encouraged and recommended that product packaging be recycled and reused according to local laws.



Power Specifications

Electrical Ratings

Input	120VAC
-------	--------

Operating Conditions

Temperature	0°C - 40°C
-------------	------------

Humidity	20% to 80% (non-condensing)
----------	-----------------------------

Storage Conditions

Temperature	-20°C - 50°C
-------------	--------------

Humidity	10% to 95% (non-condensing)
----------	-----------------------------

中国RoHS认证

根据中国法律（电子信息产品污染控制管理办法），本节将列出本产品可能含有的有毒或有害材料的名称和含量。

部件名称	有毒或有害物质与元素					
	铅 (Pb)	汞 (Hg)	镉 (Cd)	六价铬 (Cr6+)	多溴联苯 (PBB)	多溴联苯醚 (PBDE)
塑料部件	○	○	○	○	○	○
金属零件	X	○	○	○	○	○
电线和电缆 组件	X	○	○	○	○	○
液晶显示面板	X	○	○	○	○	○
触摸屏面板	X	○	○	○	○	○
印制线路板	X	○	○	○	○	○
软件（CD等）	○	○	○	○	○	○

本表格依据 SJ/T 11364 的规定编制。
○：表示该有害物质在该部件所有均质材料中的含量均在 GB/T 26572 规定的限量要求以下。
X：表示该有害物质至少在该部件的某一均质材料中的含量超出GB/T 26572规定的限量要求.对于带X的项目，已经根据欧洲RoHS认证豁免。

标志说明

(2) 根据 SJ/T11364 的要求，电子信息产品标有以下污染控制标识。此产品在 10 年内不会对环境产生影响。



(2) 绿色产品标识



Section 5: Warranty Information

For warranty information, go to <http://support.elotouch.com/warranty/>

Notes

www.elotouch.com

Visit our website for the latest

- Product Information
- Specifications
- Upcoming Events
- Press Releases
- Software Drivers

To find out more about our extensive range of Elo touch solutions, go to www.elotouch.com, or call the office nearest you.

North America

Tel +1 408 597 8000
Fax +1 408 597 8001
customerservice@elotouch.com

Europe

Tel +32 (0)16 70 45 00
Fax +32 (0)16 70 45 49
elosales@elotouch.com

Asia-Pacific

Tel +86 (21) 3329 1385
Fax +86 (21) 3329 1400
www.elotouch.com.cn

Latin America

Tel 786-923-0251
Fax 305-931-0124
www.elotouch.com

