



DESIGN
ENVELOPE

Tango™
Intelligent Variable
Speed pumps

SOLUTION OUTLINE

FILE NO: 100.20UK
DATE: OCTOBER 2017

SUPERSEDES: 100.20UK
DATE: AUGUST 2017

ARMSTRONG

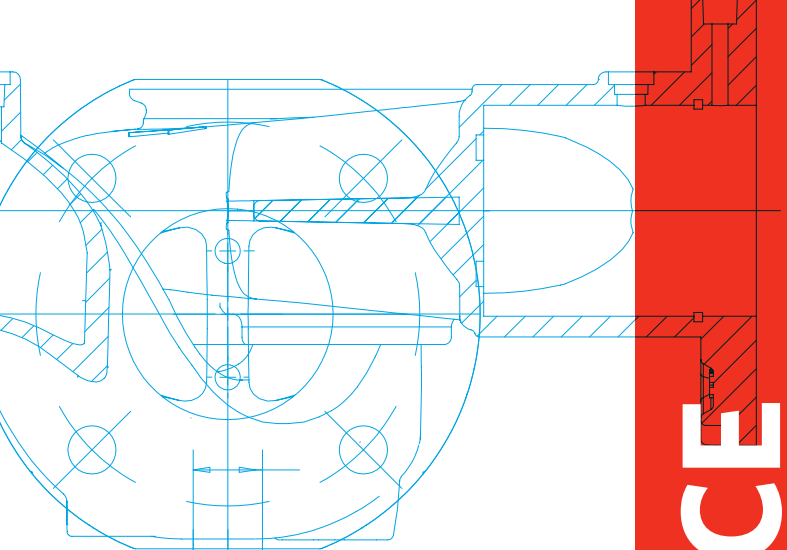

LIVING

PERFORMANCE

Continued and accelerated demand for sustained efficiency and maximum lifetime value has inspired next-level thinking in pumping solution design.

Decades of innovation have brought us to this point. Engineers, contractors, developers and owners have seen the possibilities for well-designed solutions to provide exponentially more value than the solutions offered just a few years ago.

Now, with the technological advances in digital control and internet-based connectivity, Armstrong has taken innovation to a new level.

GET SUPERIOR VALUE WITH DESIGN ENVELOPE TANGO

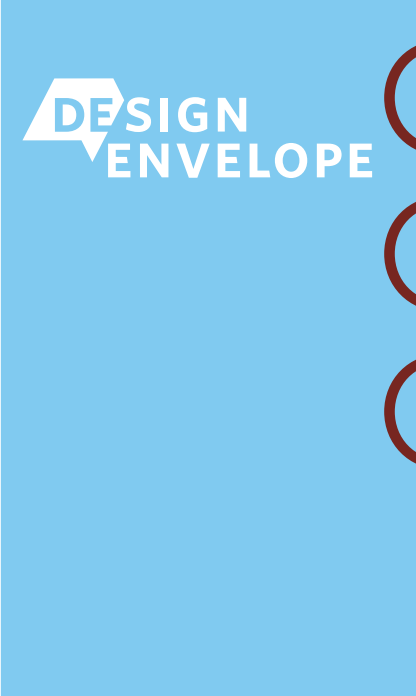

- 1** Unmatched energy efficiency
- 2** Absolute lowest installed cost
- 3** Always available: redundancy AND performance, at last

NEXT LEVEL THINKING

PARALLEL SENSORLESS

Parallel Sensorless Pump Control (PSPC) is a patented technology that improves the efficiency of a multi-pump installation through optimised load sharing. The traditional approach to control in a multi-pump installation involves staging pumps on the basis of motor speed. PSPC technology stages pumps based on operating efficiency rather than motor speed and improves the efficiency of the full pump array by up to 30% over traditional multi-pump installations.

HVAC loads and flow requirements change throughout the day. In the graph below, the point where the dotted vertical lines intersect the system efficiency curves represent the flow level at which one pump in the array should be staged on or off. Staging pumps at any other point forces the pump array to operate at efficiency levels that are less than optimal. In a multi-pump installation, Parallel Sensorless Pump Control monitors pump speed and stages pumps at the correct flow levels to optimise efficiency.

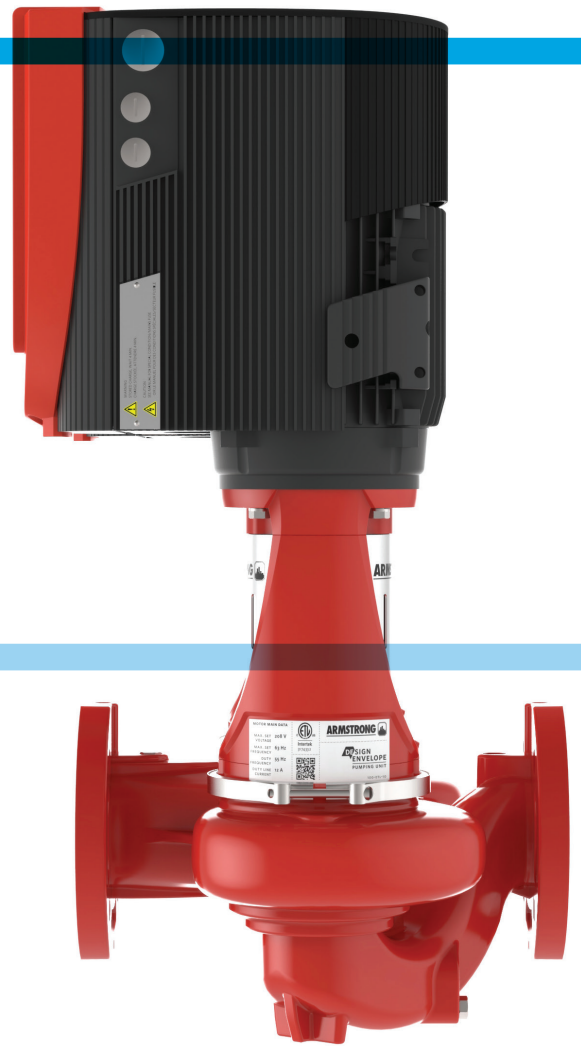
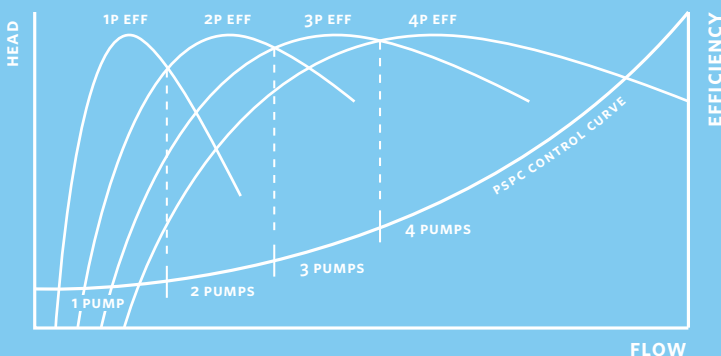

1 UNMATCHED ENERGY EFFICIENCY

Advanced hydraulic design supports industry-leading flow efficiency

Built-in Parallel Sensorless pump control saves up to 30% more energy

Armstrong iECM intelligent motor technology delivers an additional 3% - 12% efficiency, meeting IE5 efficiency standards

Control algorithm reviews operating conditions constantly and adjusts output to meet immediate flow requirements at a minimum of energy consumption

2 ABSOLUTE LOWEST INSTALLED COST: TWO'S BETTER THAN ONE

Saves one pipe drop plus related valves and fittings
for greatly reduced installation costs

Saves up to 80% in mechanical room space
with reduced footprint

One rotating assembly can be removed for service:
remaining unit provides 75-100% of total flow

Weight of motor and casing is reduced by
up to 80% for easier handling

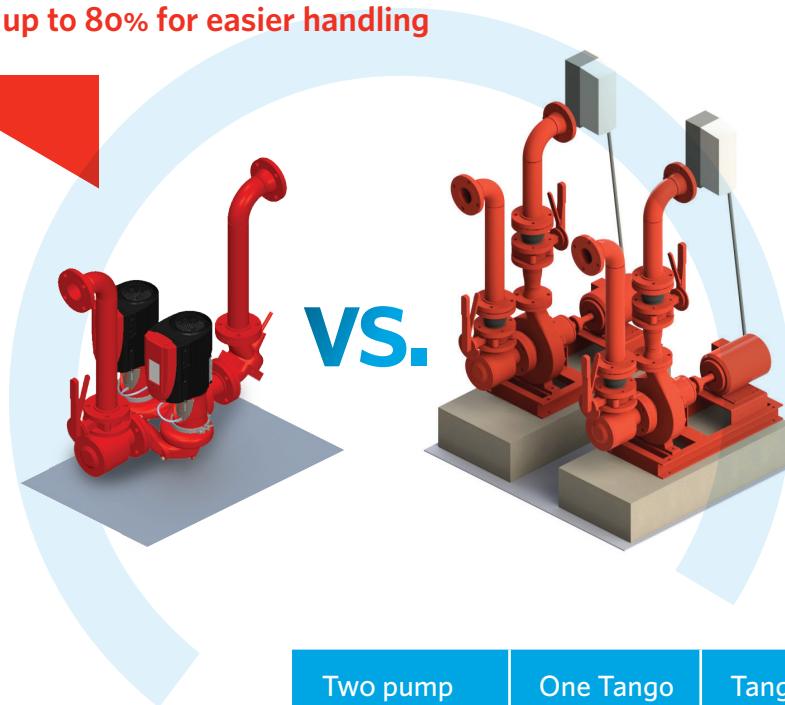

NEXT
LEVEL
THINKING

	Two pump duty/standby	One Tango pump	Tango savings
Total pump weight	811.9 kg	86.6 kg	89%
Installation weight	1198.4 kg	322.9 kg	73%
Installation footprint	1.12 m ²	0.46 m ²	81%
Installation cost	£ 4645	£ 1967	58%

3 ALWAYS AVAILABLE

Most building HVAC systems operate at the design point (100% load) less than 1% of the time. Traditional system design applies 100% redundancy and duplication of components to ensure that the design point can always be met. This creates huge overcapacity with related inflation of costs.

The traditional duty/standby approach to redundancy in HVAC systems inflates the installed costs for equipment and labor, and adds to the carbon footprint of the building. The dual-pumping configuration of Tango enables an updated approach to redundancy. Pumps and motors are selected from a range of sizes to achieve a level of redundancy that matches the requirements of the application.

For example, instead of a pump configuration of 2 × 100% for full redundancy, designers can choose 2 × 50%. In this configuration, if one pump fails, the remaining pump provides 75–80% of the total flow. This low-level supports 90–95% of design point heat transfer, resulting in a temperature variation of only 2°.

With the proper approach to redundancy, even in the event of a breakdown, HVAC requirements can be met for all but the most extreme days of the year; and for those few days, variation in temperature will be minimal.

POWER > FLOW > HEAT TRANSFER

HVAC system flow rate depends on the pressure created by the pump, and pumping pressure is created by motor power. But it's not the straight-line relationship one might imagine.

Number of pumps	% of total kW of each pump	Redundancy range (flow)	Resulting heat transfer
1	100%	0%	0%
2	50%	75–80%	90–95%
2	70%	85–90%	97%+
2	100%	100%	100%

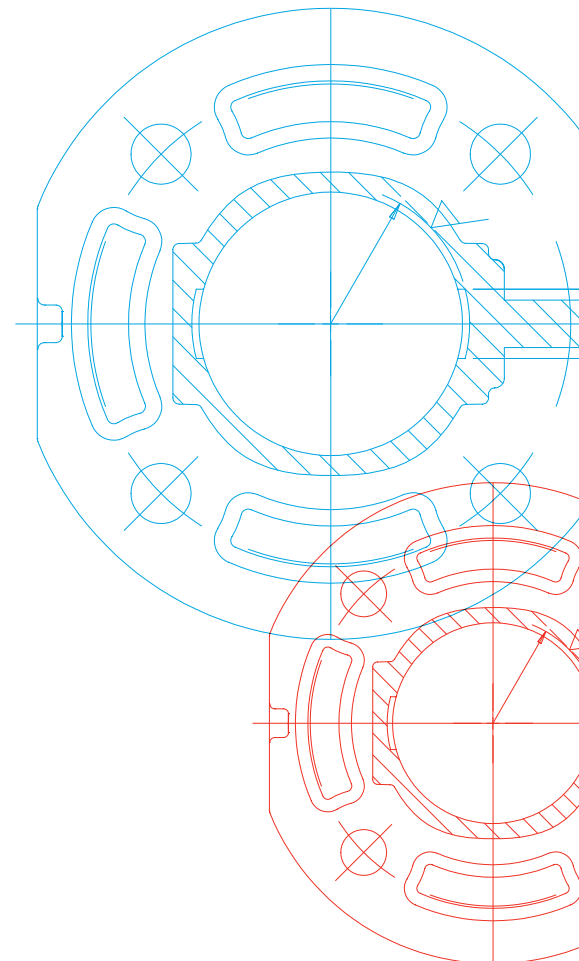

GOODBYE

DUTY STANDBY

DESIGN ENVELOPE PARALLEL SAVINGS

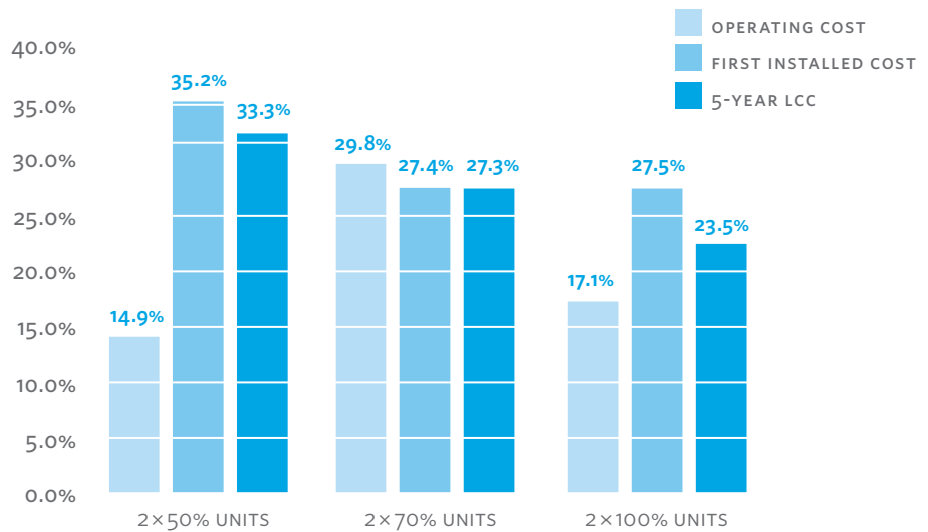

Comparing the Design Envelope Tango in different redundancy configurations against a standard end suction horizontal duty/standby configuration reveals the savings in installed cost, operating cost and five-year lifecycle cost. Even in mission-critical applications requiring 100% redundancy, the operating cost savings from Design Envelope technology and Parallel Sensorless Pump Control combined with the installed cost savings of Tango, saves more than 23% over the first five years.

Redundancy level (min)	General use ≥ 70%	Highly comfort-sensitive sectors ≥ 85%	Mission critical ≥ 100%
Sample buildings	School, apt/condo, factory/warehouse	University, campus, commercial hotel, office, mixed-use, hospital outpatients	Data center, critical care, blood bank, labs/R&D, hospital outpatients
Recommendation	Tango 2x50%	Tango 2x70%	Tango 2x100%



CONNECTIVITY

Built-in Wi-Fi capability supports remote control, real-time monitoring and management for lowest operating costs

Local and remote access from any smart device

Adaptive browser-compatible software and intuitive user interface

NEXT LEVEL THINKING

ADVANCED PERFORMANCE CONTROL

Expanded performance range (and options)

One-touch auto-flow balancing

Pump speed modulation based on an adjustable quadratic control curve for better part-load efficiency

Armstrong has reinvented and redesigned pumping solutions to include connectivity and performance management services. Design Envelope provides optimal lifetime efficiency through:

Flow monitoring accuracy (+/- 5%)

Operating data and notifications to support diagnostics and service

Advanced onboard control functions

OPTIONAL SERVICES FOR SUPERCHARGED VALUE

PERFORMANCE PACKAGES

FUNCTIONS INCLUDED



Sensorless Bundle (standard)

- Sensorless control
- Flow readout
- Constant flow
- Constant pressure



Parallel Sensorless (standard on Tango and dualARMs)

- Parallel Sensorless control



Energy Performance Bundle

- Auto-flow balancing
- Maximum flow control



Protection Bundle

- Minimum flow control
- Bypass valve control



Zone optimisation

- Accept up to two dP sensor control signals



Dual-season setup

- Pre-set heating and cooling parameters for two-pipe systems

PERFORMANCE MANAGEMENT

Studies of HVAC systems suggest that improper installation can reduce system-wide efficiency by up to 30%. Separate studies conducted by the Lawrence Berkeley national laboratory found that regular commissioning of the equipment prevented a 9% performance degradation over time. Leveraging the embedded intelligence and Wi-Fi capabilities of Design Envelope, Armstrong now offers Pump Manager, a service to help operators maintain optimal long-term pump efficiency and overall performance.

Maximise uptime

Avoid emergency repair costs through cost-effective, proactive maintenance

Maintain "as commissioned" efficiency

TANGO APPLICATION RANGE

TORONTO

23 BERTRAND AVENUE
TORONTO, ONTARIO
CANADA
M1L 2P3
+1 416 755 2291

BUFFALO

93 EAST AVENUE
NORTH TONAWANDA, NEW YORK
U.S.A.
14120-6594
+1 716 693 8813

BIRMINGHAM

HEYWOOD WHARF, MUCKLOW HILL
HALESOWEN, WEST MIDLANDS
UNITED KINGDOM
B62 8DJ
+44 (0) 8444 145 145

MANCHESTER

WOLVERTON STREET
MANCHESTER
UNITED KINGDOM
M11 2ET
+44 (0) 8444 145 145

BANGALORE

#59, FIRST FLOOR, 3RD MAIN
MARGOSA ROAD, MALLESWARAM
BANGALORE, INDIA
560 003
+91 (0) 80 4906 3555

SHANGHAI

NO. 1619 HU HANG ROAD, XI DU TOWNSHIP
FENG XIAN DISTRICT, SHANGHAI
P.R.C.
201401
+86 21 3756 6696

SÃO PAULO

RUA JOSÉ SEMIÃO RODRIGUES AGOSTINHO,
1370 GALPÃO 6
EMBU DAS ARTES
SÃO PAULO, BRAZIL
+55 11 4781 5500

ARMSTRONG FLUID TECHNOLOGY
ESTABLISHED 1934

ARMSTRONGFLUIDTECHNOLOGY.COM

4322 SPLIT-COUPLED DESIGN ENVELOPE

INDOORS	OUTDOORS
0.75-7.5 kW	0.75-7.5 kW

4372 CLOSE-COUPLED DESIGN ENVELOPE

INDOORS	OUTDOORS
0.75-7.5 kW	0.75-7.5 kW

Armstrong Design Envelope pumps are available for outdoor applications in Series 4322 and 4372.

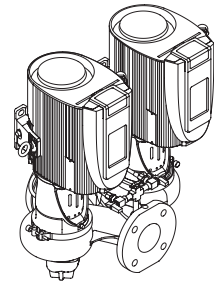

4322/4372
Split and close-coupled Tango

For applications requiring more than 7.5 kW, please use the Armstrong dualArm pump (up to 75 kW).

For more information on Tango pumps or Design Envelope technology please contact your local Armstrong representative or visit our website at:

ArmstrongFluidTechnology.com/UK

MAKING
ENERGY
MAKE
SENSETM