

The Air Brake Handbook

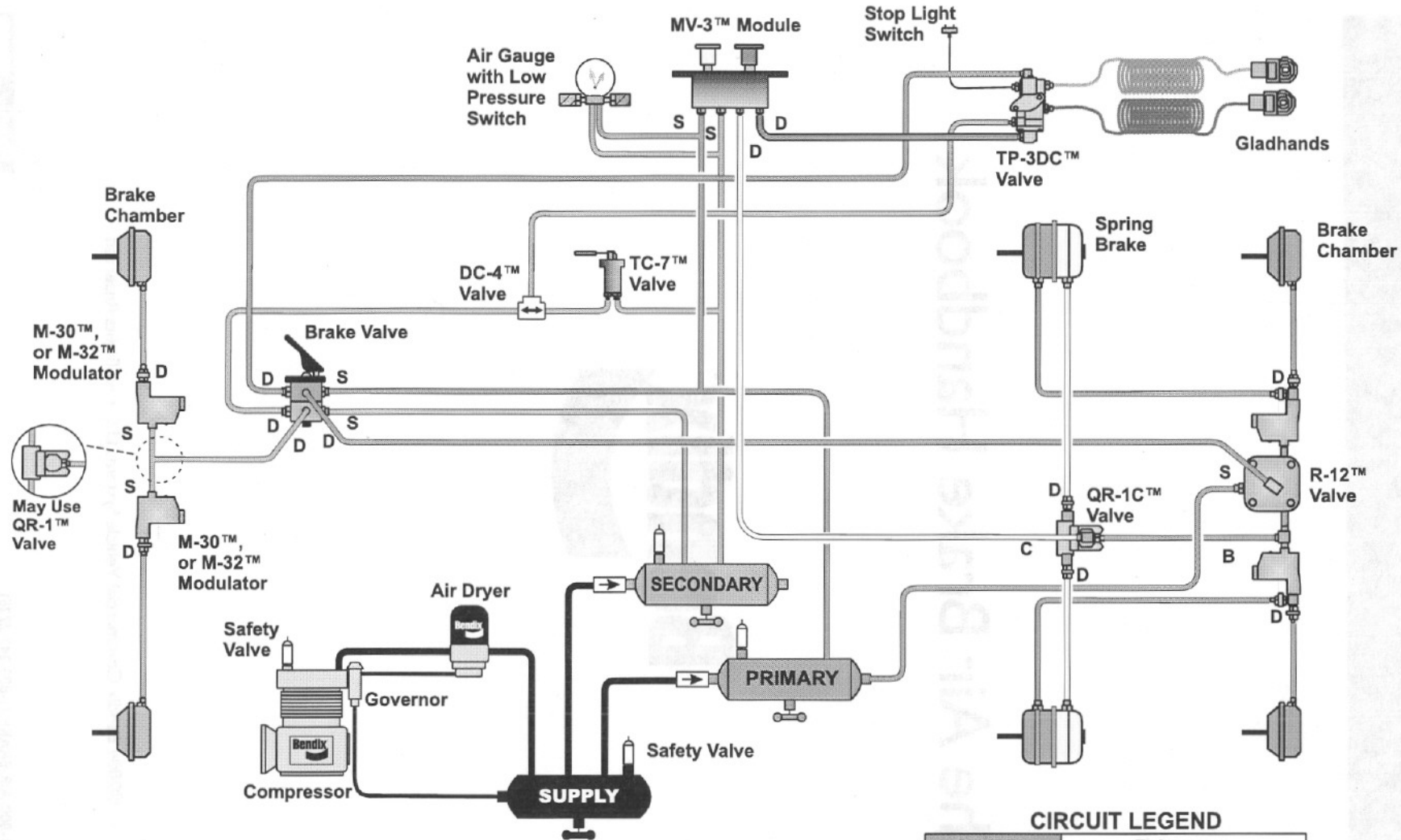

©2004 Bendix Commercial Vehicle Systems LLC • All Rights Reserved



CIRCUIT LEGEND

GREEN	Primary
ORANGE	Secondary
YELLOW	Parking
BLACK	Charging
RED	Park Supply

The Air Brake Handbook



©2004 Bendix Commercial Vehicle Systems LLC • All Rights Reserved

Device Index

A

A-18™ Controller Assy. 42
 Actuators 17
 AD-2™ Air Dryer 12
 AD-4™ Air Dryer 12
 AD-9™ Air Dryer 12
 AD-IP™ Air Dryer 12
 AD-IS™ Air Dryer Module 12
 AD-SP™ Air Dryer 13
 AF-3™ In-line Air Filter 13
 Air Disc Brakes 20
 ASA-5™ Automatic Slack Adjuster .. 18

B

BA-922™ Air Compressor 8
 BA-921™ Air Compressor 8, 9
 BA-922™ Air Compressor 9
 BASIC™ Test Kit 9
 Bendix Modules 45
 BP-1™ Brake Proportioning Valve .. 22
 BP-R1™ Bobtail Proportioning
 Relay Valve 22
 BVA-85™ Brake Valve Actuator 46
 BX-2150™ Air Compressor 8

C

Converter Dolly Brakes 33
 Cyclone DuraDrain™ Trailer
 Water Separator 13

D

D-2™ Governor 10
 DC-4™ Double Check Valve 14
 DD3® Safety Actuator 17
 Dryer Reservoir Module 12
 DS-2™ Double Check and Stop
 Light Switch 14
 DuraFlo™ 596 Air Compressor ... 8, 9

E

E-10™ Brake Valve 15
 E-10P™ Brake Valve 15
 E-10PR™ Brake Valve 15
 E-10PR™ Retarder Control
 Brake Valve 16
 E-12™, E-15™ Brake Valves 15
 E-14™ Brake Valve 15
 E-6™ Brake Valve 15
 E-7™ Brake Valve 15
 E-8P™ Brake Valve 15
 EC-30™ ABS/ATC Controller 36
 EC-60™ ABS/ATC Controller 36
 ESP® Functionality 39
 ET-S™ and ET-S2™ Electronic
 Throttle/Treadles 46
 EverFlow™ Module 13

F

FD-3™ Fan Clutch 46
 FD-1™ Fan Clutch 46

I

Inlet Check Valve 10
 Inlet Regulating Valve 10

L

LP-2™ and LP-3™ Low Pressure
 Indicators 11
 LQ-4™ Ratio Valve 21
 LQ-4™ Ratio Valve 21
 LQ-4™ Valve 21
 LQ-5™ Bobtail Ratio Valve 22

M

M-32™ and M-32QR™ Modulators . 35
 MC-30™ Controller Assy. 42
 MV-3™ Dash Control Module 29

P

PE-4™ Control Valve 32
 PP-1™ and PP-2™ Valves 24
 PP-1™ Control Valve 34
 PP-3™ Control Valve 24
 PP-5™ Push-Pull Control Valve 27
 PP-7™ Control Valve 24
 PP-8™ Control Valve 24
 PP-DC™ Park Control Valve 28
 PR-3™ Reservoir Control Valve 34
 PR-4™ Pressure Protection Valve .. 14
 PuraGuard® QC™ Oil
 Coalescing Filter 13

Q

QR-1™ Quick Release Valve 21
 QR-1C™ Quick Release Valve 26
 QR-L™ Inline Quick Release Valve . 21
 QRN-2™ Quick Release Valve 21
 QRV™ Quick Release Valve 21

R

R-12DC™ Relay Valve 23
 R-12P™ Relay Valve 23, 34
 R-12™ Relay Valve 23
 R-14™ Relay Valve 23
 R-6™ Relay Valve 23
 R-7™ Modulating Valve 23
 R-8P™ Relay Valve 23
 R-8™ Relay Valve 23
 RD-3™ Control Valve 27
 RDU™ (Remote Diagnostic Unit) .. 44
 RE-6NC™ Relay Emergency Valve .. 34
 Reservoirs 11
 RV-1™ Pressure Reducing Valve 14

S

S-Cam Brakes 19
 SB-1™ Spring Brake Actuator 17
 SC-3™ Single Check Valve 11
 SC-PR™ Valve 13
 SD-3™ Roto Safety Actuator 17
 SL-4™ and SL-5™ Stop Lamp
 Switches 26
 Spring Brake Actuators 17
 SR-2™ Spring Brake Valve 31
 SR-4™ Spring Brake Valve 31
 SR-5™ Spring Brake Valve 31
 ST-1™, ST-3™ and ST-4™
 Safety Valves 10
 SureStroke™ Indicator 18
 SV-1™ Synchro Valve 27, 34
 SV-4™ Trailer Release Valve 34
 System-Guard® Trailer Air Dryer .. 13

T

TC-2™ Trailer Control Valve 29
 TC-6™ Trailer Control Valve 29
 TE-1™ Trailer Emergency Stop Light 32
 TP-3™ Tractor Protection Valve 30
 TP-3DC™ Tractor Protection Valve . 30
 TP-4™ Tractor Protection Valve 30
 TP-5™ Tractor Protection Valve 30
 TR-2™ Valve 27
 TR-3™ Valve 27
 TR-5™ Lock Line Control Valve 32
 Trailer Control (TC) Valves 29
 Tu-Flo® 550 Air Compressor 8, 9
 Tu-Flo® 750 Air Compressor 8, 9
 TW-1™, TW-3™ and TW-6™
 Control Valves 26
 TW-11™ Valve 26

V

Vision Systems 45

W

WS-24™ Wheel Speed Sensors 35

Y

Yaw Stability 39

How to use the Air Brake Handbook

This nine-section handbook provides an introduction to the use and operation of Bendix air brake systems and devices.

Components are introduced and shown with typical system diagrams to show where they are used. As new components are introduced and their function explained, they gradually build up to a complete functioning air brake system.

Partial system-drawings, throughout the manual, assist in explaining of the use of the components. See the front inside cover for an example of a tractor system schematic in color.

Device Index	2
Air Brake System General Precautions	4
General Precautions	4

Section One: A One-Page Introduction to Air Brake Systems 5

Section Two: The Charging System 6-14

Overview	6
Compressors	7-8
Compressor Maintenance Guidelines	9
Governors and Components	10
Reservoirs and Components	11
Air Dryers	12
Air Dryers and Filters	13
Miscellaneous Charging System Related Components	14

Section Three: The Control System 17-32

Dual Circuit Brake Valves	15-16
Actuators	17
Slack Adjusters	18
Foundation Brakes	19-20
Quick Release, Ratio Valves	21
Ratio, Proportioning Valves	22
Relay Valves	23
Push-Pull Valves	24
Spring Brake Valves	25
Lever Operated Control Valves	26
Miscellaneous Control Valves	27

Section Four: Tractor/Trailer Parking and Emergency Systems 28-32

Systems	28-29
Dash Control Modules	29
Tractor Protection Valves	30
Trailer Spring Brake Valves	31-32

Section Five: Trailers/Converter Dolly Brakes 33-34

Section Six:

Antilock Braking Systems (ABS) 35 - 48

ABS Components, Truck and Tractor ABS Operation	35-36
Truck and Tractor ABS Operation, ATC	37
Straight Truck Sample Schematic	38
Advanced ABS	39
Advanced ABS Operation	40
Advanced ABS Features	40-41
Trailer ABS Components and Operation	42
Trailer ABS Operation and Features, PLC	43
Troubleshooting ABS	43-44

Section Seven: Miscellaneous commercial vehicle products from Bendix 45-46

Section Eight:

Air Brake System Fundamentals	47
Braking Force	48
Leverage	49-50
Deceleration	50-51
Compressed Air	51-53
Compressed Air Brakes	54
S-Cam and Air Disc Brakes	55
Air Brake System Balance: Pneumatic Systems ..	56
Air Brake System Balance: Mechanical Systems ..	57

Section Nine: Air Brake System

Troubleshooting Tests 58-60

Bendix Videos and Literature	61-62
------------------------------------	-------

List of Service Data Sheets	63
-----------------------------------	----

Sample Schematic	inside front cover
------------------------	--------------------



DIN symbols are used in this handbook.

IMPORTANT

The systems presented in this manual are intended for illustrative purposes only and are not intended to be used for actual vehicle piping.

Air Brake System General Precautions**WARNING! PLEASE READ AND FOLLOW THESE INSTRUCTIONS TO AVOID PERSONAL INJURY OR DEATH:**

When working on or around a vehicle, the following general precautions should be observed at all times.

1. Park the vehicle on a level surface, apply the parking brakes, and always block the wheels. Always wear safety glasses.
2. Stop the engine and remove ignition key when working under or around the vehicle. When working in the engine compartment, the engine should be shut off and the ignition key should be removed. Where circumstances require that the engine be in operation, **EXTREME CAUTION** should be used to prevent personal injury resulting from contact with moving, rotating, leaking, heated or electrically charged components.
3. Do not attempt to install, remove, disassemble or assemble a component until you have read and thoroughly understand the recommended procedures. Use only the proper tools and observe all precautions pertaining to use of those tools.
4. If the work is being performed on the vehicle's air brake system, or any auxiliary pressurized air systems, make certain to drain the air pressure from all reservoirs before beginning **ANY** work on the vehicle. If the vehicle is equipped with an AD-IS™ air dryer system or a dryer reservoir module, be sure to drain the purge reservoir.
5. Following the vehicle manufacturer's recommended procedures, deactivate the electrical system in a manner that safely removes all electrical power from the vehicle.
6. Never exceed manufacturer's recommended pressures.
7. Never connect or disconnect a hose or line containing pressure; it may whip. Never remove a component or plug unless you are certain all system pressure has been depleted.
8. Use only genuine Bendix® replacement parts, components and kits. Replacement hardware, tubing, hose, fittings, etc. must be of equivalent size, type and strength as original equipment and be designed specifically for such applications and systems.
9. Components with stripped threads or damaged parts should be replaced rather than repaired. Do not attempt repairs requiring machining or welding unless specifically stated and approved by the vehicle and component manufacturer.
10. Prior to returning the vehicle to service, make certain all components and systems are restored to their proper operating condition.
11. For vehicles with Antilock Traction Control (ATC), the ATC function must be disabled (ATC indicator lamp should be ON) prior to performing any vehicle maintenance where one or more wheels on a drive axle are lifted off the ground and moving.

Section I: One-Page Introduction

Air Supply

The vehicle's compressor takes in filtered air, either at atmospheric pressure from the outside (or already at an increased pressure, from the engine turbocharger in some cases), and compresses it. The compressed air is delivered to the air dryer where water and a small amount of oil is removed. The air then travels into the air reservoirs ("air tanks") - typically delivered to a rear brake system reservoir and a front brake system reservoir as well as any attached trailer reservoirs. For each system, the air pressurizes the reservoir and the air hoses all the way to the next control valve, where the air pressure remains, ready to be used.

A vehicle may use compressed air for many tasks. Some examples are: to provide force for braking, to deliver air to a particular component, to off-load bulk goods, etc.

Normal Braking

When the driver applies the foot brake, a plunger within the foot brake valve moves, opening channels within the valve that allow the air pressure waiting there to pass through and be delivered to the rear and front brake systems. The pressure quickly increases in the brake chambers and applies force to the push rod, transferring the force to the S-Cam or air disc brake. (See page 22 for more about foundation brakes.) Frictional forces slow the wheels and the vehicle comes to a stop. When the brakes are released, the air in the brake chambers is able to be quickly released and enable the driver to drive away.

Vehicle Parking

Vehicles are parked using powerful springs which are part of the spring brake assembly, to engage the brakes and hold the vehicle in position. When the driver prepares to move away and releases the parking brake, the spring force is countered by the introduction of air pressure. Anti-compounding valve features in the system design help prevent the application of both the spring and service brakes together.

Antilock Braking Systems (ABS)

Most commercial vehicles use electronic Antilock Braking System (ABS) to help improve braking when excessive wheel slip, or wheel lock-up, is detected. Bendix® Electronic Control Units (ECUs) use patented technology to monitor wheel speeds (on all wheels equipped with speed sensors) and use ABS modulator valves to adjust or pulse the braking force being applied and released, many times per second, during an ABS event. ABS typically improves stability and steerability, and also reduces stopping distances on most surfaces.

In addition to the ABS features above, some recent model ECUs have a drag torque control feature which reduces driven-axle wheel slip (due to driveline inertia) by communicating with the engine's controller and increasing the engine torque.

Antilock Traction Control

In addition to the ABS function, some Bendix ECU models provide an Automatic Traction Control (ATC) feature which can help improve vehicle stability and traction during vehicle acceleration (at low speeds), and lateral stability while driving through curves.

Electronic Stability Program (ESP®)

Recent Bendix® ABS advances include ESP® which has the ability to apply brakes to individual wheel ends, and the trailer, to counteract the trailer "push" during maneuvers that may lead to loss of control or jackknives on low to high friction surfaces (snow, rain, asphalt, concrete, etc.)

Roll Stability Program (RSP)

The Bendix Roll Stability Program (RSP), is an all-axle ABS solution that helps reduce vehicle speed by applying all vehicle brakes as needed, reducing the tendency to roll over. RSP focuses on reducing the vehicle's speed below the critical roll threshold during direction-changing maneuvers such as exit ramps and obstacle avoidance on dry, high friction surfaces.

Emergency Braking

In emergency situations where system air pressure is reduced or lost, government regulations require vehicles to meet specified stopping distances. As an example, some straight truck system designs use modulated parking-brake applications to bring the vehicle to a stop.

Vision Systems

Bendix offers video camera systems that help drivers back vehicles up safely, assist drivers with viewing what is in their blind spots around their vehicles, as well as infrared XVision® night vision camera systems that provide drivers advanced warning of obstacles in their pathway at night by seeing 3 to 5 times further than their standard headlights. All of our camera systems can be purchased individually to meet drivers' specific needs or can be purchased as a total system to provide a complete 360 degree 24/7 video camera system for drivers.

*ESP is a registered trademark of Daimler Chrysler.

Section 2: The Charging System

The charging system consists of:

- An **air compressor**
 - A **governor**, to control when the compressor needs to build, or stop building, air for the system and also to control the air dryer purge cycle
 - An **air dryer**, to remove water and oil droplets from the air
 - **Reservoirs** (or “air tanks”) to store air to be used for vehicle braking, etc.
- **Safety valves** to protect against excessive pressure in the system in the event that a charging system component malfunction occurs, e.g. a line blockage
 - **Single check valves** to maintain a one-way flow of air into the reservoirs. This arrangement protects the contents from being drained in the event of an upstream loss of pressure
 - **Low pressure indicators** to alert the driver whenever a reservoir has less than a pre-set amount of air available

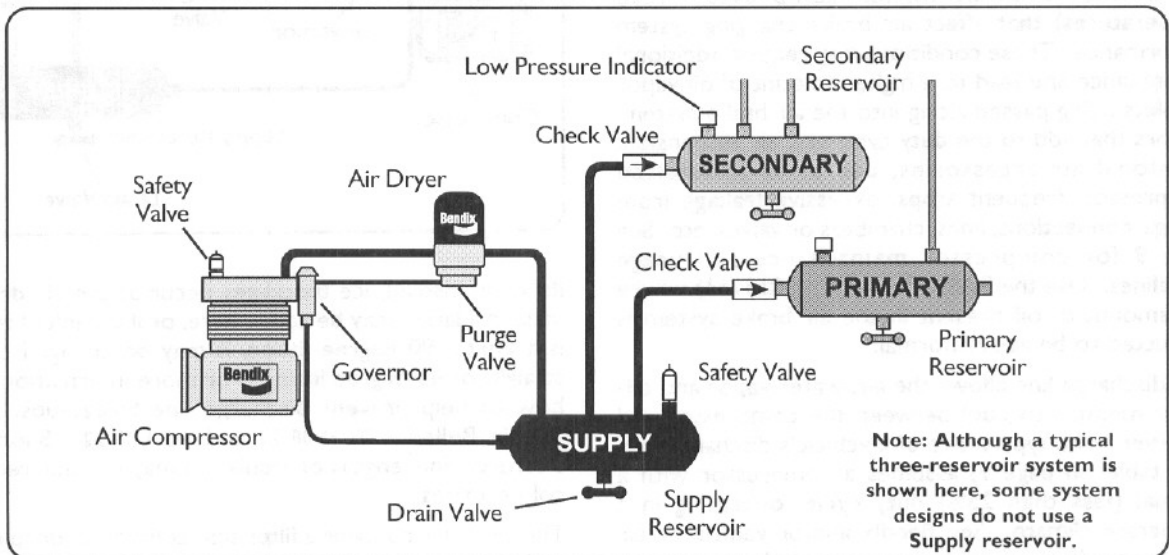

Bendix Air Compressors

The air compressor is the source of energy for the air brake system.

Usually driven by the vehicle engine, the air compressor builds the air pressure for the air brake system. The air compressor is typically cooled by the engine coolant system and lubricated by the engine oil supply. (Certain models have self-lubricated and/or air-cooled versions available.) Note: Air compressor shafts can rotate in either direction.

The vehicle's compressor draws in filtered air, either at atmospheric pressure from the outside (or already at an increased pressure, from the engine turbocharger where permitted), and compresses it.

The brake system needs a supply of compressed air between a preset maximum and minimum. The governor (along with a synchro valve for the Bendix® DuraFlo™ 596 air compressor) monitors the air pressure in the supply reservoir and controls when the compressor needs to pump air into the air system (also known as the “air build cycle” - the compressor is “running loaded”) and when the compressor should simply turn over without building pressure (“running unloaded”). When the air pressure becomes greater than that of the preset “cut-out”, the governor controls the unloader mechanism of the compressor to stop the compressor from building air and also causes the air dryer to purge. As the service reservoir air pressure

drops to the “cut-in” setting of the governor, the governor returns the compressor back to building air and the air dryer to air drying mode.

As the atmospheric air is compressed, all the water vapor originally in the air is carried along into the air system, as well as a small amount of the compressor lubricating oil as vapor.

The duty cycle is the ratio of time the compressor spends building air to the total engine running time. Air compressors are designed to build air (run “loaded”) up to 25% of the time. Higher duty cycles cause conditions (such as higher compressor head temperatures) that affect air brake charging system performance. These conditions may require additional maintenance and lead to a higher amount of oil vapor droplets being passed along into the air brake system. Factors that add to the duty cycle are: air suspension, additional air accessories, use of an undersized compressor, frequent stops, excessive leakage from fittings, connections, lines, chambers or valves, etc. See page 9 for compressor maintenance and usage guidelines. Use the BASIC™ test (p/n 5013711) where the amount of oil present in the air brake system is suspected to be above normal.

The discharge line allows the air, water-vapor and oil-vapor mixture to cool between the compressor and air dryer. The typical size of a vehicle’s discharge line, (see table on page 9) assumes a compressor with a normal (less than 25%) duty cycle, operating in a temperate climate. See Bendix and/or vehicle or air dryer manufacturer guidelines as needed.

When the temperature of the compressed air that enters the air dryer is within the normal range, the air dryer can remove most of the charging system oil. If the temperature of the compressed air is above the normal range, oil as oil-vapor is able to pass through the air dryer and into the air system. Air dryer inlet temperatures play a key role in air system cleanliness and air dryer performance. Larger diameter discharge lines and/or longer discharge line lengths can help reduce the temperature.

The discharge line must maintain a constant slope down from the compressor to the air dryer inlet fitting to avoid low points where ice may form and block the

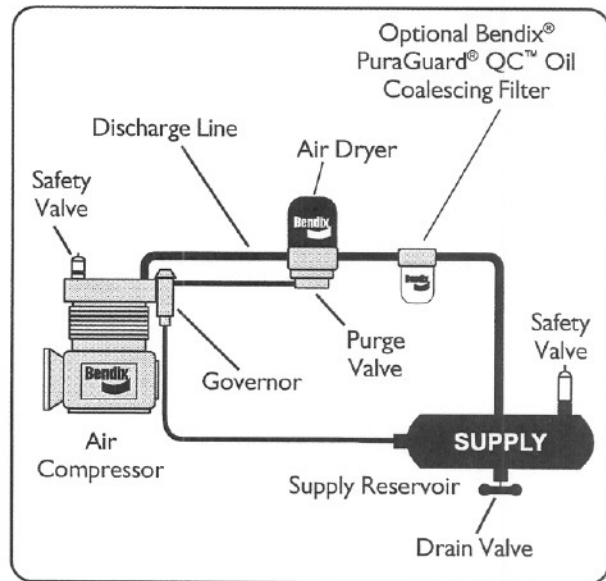

flow. If, instead, ice blockages occur at the air dryer inlet, insulation may be added here, or if the inlet fitting is a typical 90 degree fitting, it may be changed to a straight or 45 degree fitting. For more information on how to help prevent discharge line freeze-ups, see Bendix Bulletins TCH-08-21 and TCH-08-22. Shorter discharge line lengths or insulation may be required in cold climates.

The air dryer contains a filter that collects oil droplets, and a desiccant bed that removes almost all of the remaining water vapor. The compressed air is then passed to the air brake service (supply) reservoir. The oil droplets and the water collected are automatically purged at the dryer when the governor reaches its “cut-out” setting.

For vehicles with accessories that are sensitive to small amounts of oil, we recommend installation, downstream of the air dryer, of a Bendix® PuraGuard® QC™ oil coalescing filter to minimize the amount of oil present.

See the Bendix Advanced Compressor Troubleshooting Guide (BW1971) or the compressor’s Service Data sheet, available online at www.bendix.com for more information.

Single-Cylinder Compressors

BX-2150™
air
compressor

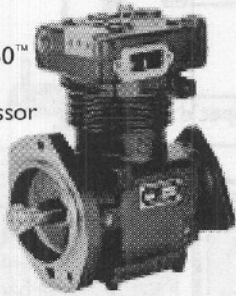

BA-921™ air
compressor

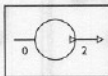
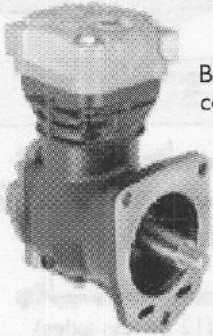

Two-Cylinder Compressors



Tu-Flo® 700 air
compressor

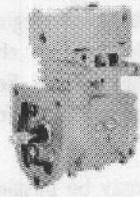

Tu-Flo® 501 air
compressor

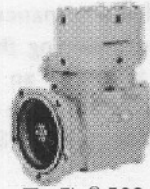

Tu-Flo® 500 air
compressor

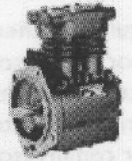

Tu-Flo® 400 air
compressor

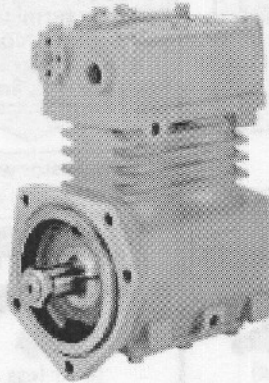

Tu-Flo® 550 air
compressor or
Tu-Flo® 750
air compressor
(exterior view
is the same)

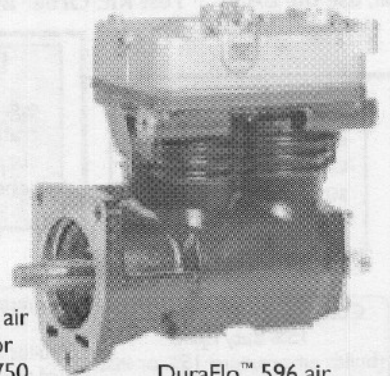

DuraFlo™ 596 air
compressor or
BA-922™ air
compressor (exterior view is
very similar)

Compressor
Comparison by
Displacement

	Displacement CFM @ 12500 RPM	Cylinders	Engine self-lubricated avail.?	Turbo inlet option? Water air-cooled avail.?	
Tu-Flo® 400 Compressor	7.25	2	Both	Y	Both
BX-2150™ Compressor	9.5	1	Eng.	Y**	Water
Tu-Flo® 500 Compressor	12	2	Eng.	Y	Water
Tu-Flo® 501 Compressor	12	2	Both	Y	Both
Tu-Flo® 550 Compressor	13.2	2	Eng.	Y	Water
Tu-Flo® 700 Compressor	15.5	2	Eng.	Y	Water
BA-921™ Compressor	15.8	1	Eng.	Y**	Water
Tu-Flo® 750 Compressor	16.5	2	Eng.	Y	Water
Tu-Flo® 1000 Compressor*	24	4	Both	Y	Both
DuraFlo™ 596 Compressor	27	2	Eng.	N	Water
BA-922™ Compressor	31.6	2	Eng.	N	Water
Tu-Flo® 1400 Compressor*	32	4	Eng.	Y***	Water

*Special use. e.g. Tank trailer pump-off

**Uses Inlet Check Valve

***Uses Inlet Regulating Valve

Four-Cylinder Compressors

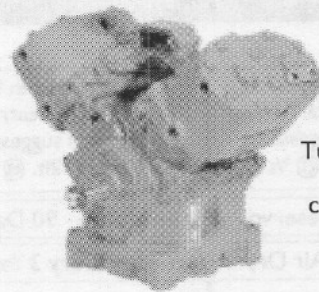

Tu-Flo® 1000
air
compressor

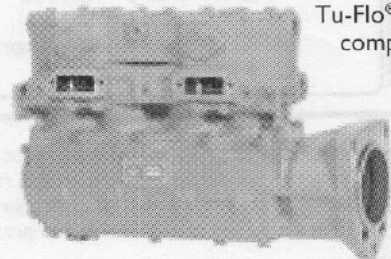

Tu-Flo® 1400 air
compressor

For compressor Service Data Sheet directory see pages 63-64.

Maintenance Schedule and Usage Guidelines

Regularly scheduled maintenance is the single most important factor in maintaining the air brake charging system. The table below is an introduction to the maintenance intervals for air brake charging systems. See your compressor and/or air dryer Service Data sheet for more information.

If you are concerned that a compressor may be passing oil, use the BASIC™ Test Kit: Order Bendix P/N 5013711.

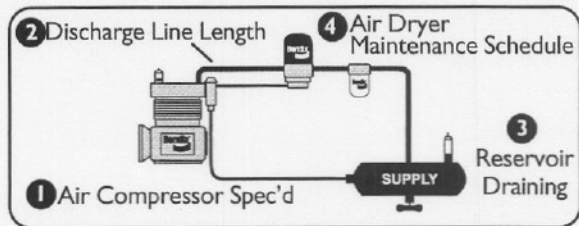

<p>Low Air Use e.g. Line haul single trailer without air suspension, air over hydraulic brakes.</p> <p>Compressor with less than 15% duty cycle (builds air pressure 15% or less of the engine running time.)</p> <p>(5 or less axles)</p>	<p>Low Air Use e.g. Line haul single trailer with air suspension, schoolbus.</p> <p>Compressor with up to 25% duty cycle (builds air pressure up to 25% of the engine running time.)</p> <p>(5 or less axles)</p>	<p>High Air Use e.g. Double/triple trailer, open highway coach/RV, (most) pick-up & delivery, yard or terminal jockey, off-highway, construction, loggers, concrete mixer, dump truck, fire truck.</p> <p>Compressor with up to 25% duty cycle</p> <p>(8 or less axles)</p>	<p>High Air Use e.g. City transit bus, refuse, bulk unloaders, low boys, urban region coach, central tire inflation.</p> <p>Compressor with up to 25% duty cycle</p> <p>(12 or less axles)</p>
<p>1 Examples of Typical Compressors Spec'd^a</p> <p>Bendix® BA-921™ air compressor</p> <p>Bendix® Tu-Flo® 550 air compressor</p> <p>Bendix® Tu-Flo® 750 air compressor</p> <p>Bendix® BA-922™ air compressor</p> <p>DuraFlo™ 596 air compressor</p>			
<p>2 Discharge line: 6 ft. @ ½ in. I.D. (oil carry-over control suggested upgrade^b: 9ft. @ ⅝ in.)</p>	<p>2 Discharge line: 9 ft. @ ½ in. I.D. (oil carry-over control suggested upgrade^b: 12ft. @ ⅝ in.)</p>	<p>2 Discharge line: 12 ft. @ ½ in. I.D. (oil carry-over control suggested upgrade^b: 15ft. @ ⅝ in.)</p>	<p>2 Discharge line: 15 ft. @ ⅝ in. I.D. (oil carry-over control suggested upgrade^b: 15ft. @ ¾ in.)</p>
<p>3 Drain Reservoirs Every Month - 90 Days</p>		<p>3 Drain Reservoirs Every Month</p>	
<p>4 Replace Air Dryer Cartridge Every 3 Years^c</p>		<p>4 Replace Every 2 Years^c</p>	<p>4 Replace Every Year^c</p>
<p>Oil Passing Concerns?</p>	<p>Use the BASIC™ Test Kit: Order Bendix P/N 5013711 BASIC™ test acceptable range: 3 oil units per month.</p> <p>Use the BASIC™ Test Kit: Order Bendix P/N 5013711 BASIC™ test acceptable range: 5 oil units per month.</p>		

a. Note: Compressor and/or air dryer upgrades are recommended in cases where duty cycle is greater than the normal range (for the examples above). For certain vehicles/applications, where turbo-charged inlet air is used, a smaller size compressor may be permissible.

b. To counter above normal temperatures at the air dryer inlet, (and resultant oil-vapor passing upstream in the air system) replace the discharge line with one of a larger diameter and/or longer length. This helps reduce the air's temperature. If

sufficient cooling occurs, the oil-vapor condenses and can be removed by the air dryer. Discharge line upgrades are not covered under warranty. Note: To help prevent discharge line freeze-ups, shorter discharge line lengths or insulation may be required in cold climates. See Bendix Bulletins TCH-08-21 and TCH-08-22, for more information.

c. With increased air demand the air dryer cartridge needs to be replaced more often.

Governors and Components

The **Governor** monitors the air pressure in the supply reservoir and operates the compressor unloading mechanism to control whether the compressor builds air pressure or not.

The **Bendix® D-2™ governor** is an adjustable piston-type valve available preset to a choice of pressure settings.

The pressure range between the cut-in and cut-out pressure is designed into the governor and is not adjustable. The D-2™ governor may be direct-mounted to the compressor or remote-mounted as desired. Specialized governors are available for vehicles needing a governor adapted to abnormally high or low temperatures, as well as a “weatherproof” model.

The D-2A™ governor is a non-adjustable version of the D-2™ governor.

The **D-2™/SV-1™ governor module** is a special combination device used with the Bendix® DuraFlo™ 596 air compressor to provide the fast-rising unloader signal needed by this compressor.

Safety Valves are used in an air brake system to protect against excessive air pressure buildup and to sound an audible alert. Safety valves are available in both adjustable (e.g. the Bendix® ST-1™ valve) and non-adjustable (e.g. ST-3™, ST-4™ valve) styles, in various pressure settings, and for various port sizes. Maximum service system air pressure allowed by government regulation is typically 150 psi. Various safety valve settings are used at different points in the charging and treatment system.

Specifically designed for use in compressors, ST-4™ safety valves are installed in an extra compressor head discharge port, if available, or in the discharge line near the compressor, to prevent compressor damage in the event of discharge line blockage.

An **Inlet Regulating Valve** (or “IRV”) is typically used on multi-cylinder compressors which receive their input air supply from the pressurized side of the engine turbocharger. The IRV, which is generally mounted to the compressor inlet, is designed to regulate compressor inlet pressure to 10 PSI or less. The outlet flange of the IRV can be mounted to all Bendix® Tu-Flo® compressors except the Bendix® Tu-Flo® 300 compressor. The IRV may not be used in conjunction with single cylinder compressors.



Inlet Check Valves (or “ICV”) are used on naturally aspirated compressors to prevent oil mist from entering the inlet line during the unloaded cycle. The inlet check valve either mounts to the intake side of the compressor (and must be used in conjunction with an inlet valve stop or inlet adapter), or may be mounted remotely.

Reservoirs (or “air tanks”) serve the air brake system as a storage tank for compressed air. The reservoir size is selected by the vehicle manufacturer to provide an adequate amount of air for use by the braking system and other control devices.

Bendix reservoirs are built in accordance with SAE specifications and are available in various sizes in both single and double compartment design configurations, and are certified to comply with government regulations (such as FMVSS 121).

Reservoir draining devices are installed in air brake reservoirs, and allow liquid contaminants collected to be drained off. Vehicles without air dryers are normally drained each day. Vehicles which have Bendix desiccant air dryers should be drained every 30-90 days. [Tip: The presence of water may indicate that the air dryer cartridge may need to be replaced. Other potential sources of water in the reservoirs are: when shop air has been used to fill the system, an excessive duty cycle, or excessive air leakage.]

Manual draining devices consist of drain cocks which require manual operation at the point at which they are installed. Drain cocks are available in various styles and pipe thread sizes. [Tip: Always drain contents slowly for best results.]

The Bendix® DV-2™ automatic reservoir drain valve is a completely automatic draining device. It is installed directly into the end or bottom drain port of the reservoir and does not require any additional control lines. It is available in either an end-port or bottom-port version, and with or without a (12v or 24v) heater. These are most suitable for systems without a desiccant air dryer.

Single Check Valves

The in-line single check valve allows air flow in one direction only. Several sizes and configurations are available to accommodate various piping arrangements. Single check valves are used in air brake systems to prevent loss of remaining system pressure if another reservoir, or hose etc. upstream in the system fails.

For double check valves and pressure protection valves, see page 14.

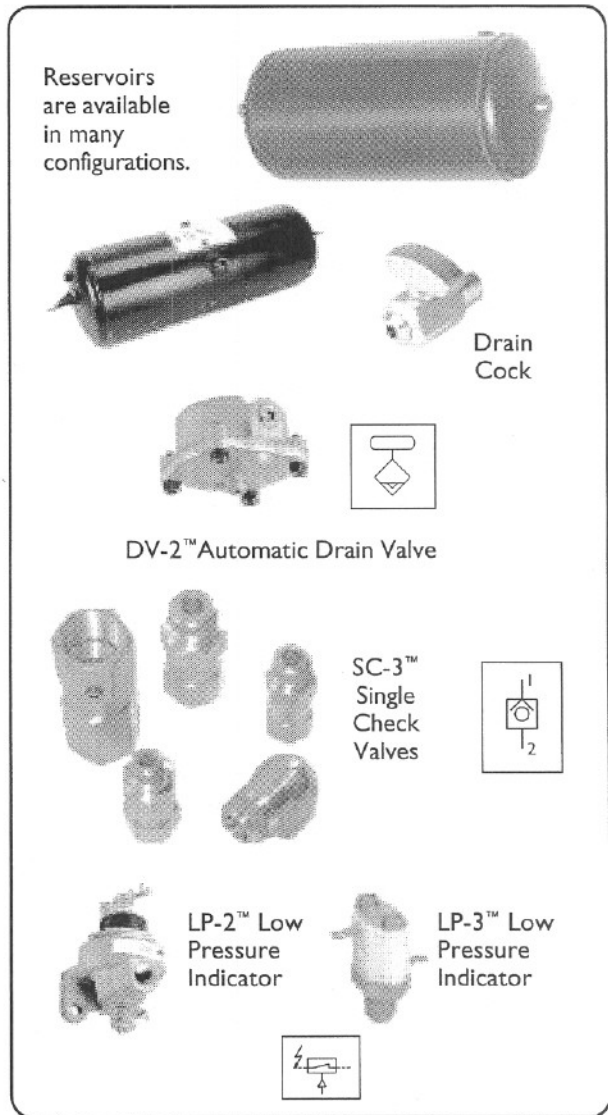

Low Pressure Indicators

Low pressure indicators are pressure-operated electro-pneumatic switches that are designed to complete an electrical circuit and actuate a warning light and buzzer for the driver in the event air pressure in the service brake system is below a minimum level for normal operation. The low pressure indicator is available in various pressure settings, is not adjustable, and is generally used in conjunction with a dash mounted warning lamp or warning buzzer or both.

Air Dryers

The air dryer is an in-line filtration system that removes both water vapor and oil droplets from the compressor discharge air after it leaves the compressor. This results in cleaner, drier air being supplied to the air brake system, and aids in the prevention of air line and component freeze-ups in winter weather.

Air dryers typically use a replaceable cartridge containing a desiccant material and an oil separator. Most of the oil droplets are removed by the oil separator as the air passes into the air dryer. The air then moves through the desiccant material which removes most of the water vapor.

When the air pressure in the supply air tank reaches the required level, the governor makes the compressor stop building air and allows the air dryer's "purge cycle" to begin. During the purge cycle the desiccant material is regenerated (its ability to remove water is renewed) by a reversal of the saturation process. A small amount of dry air passes back through the desiccant material and the water that has been collected, as well as any oil droplets collected by the oil separator, are purged out through the base of the dryer. It is normal to see a small amount of oil around the purge valve.

The air dryer end cover is typically equipped with an (12 or 24 volt) integral heating element.

The **AD-2™**, **AD-4™**, **AD-9™** and **AD-IP™** air dryers are designed with an internal storage ("purge volume") of dry air for the purge cycle.

The **AD-IS™** air dryer is an integral purge air dryer module, which includes a spin-on desiccant cartridge, governor, reservoir and charging valve components in a module. These have been designed as an integrated air supply system. The **DRM™** module includes an AD-IS™ integrated solution air dryer, a reservoir (including a separate purge reservoir section), a governor, and four pressure protection valves as an integrated air supply system.

"Extended Purge" air dryers are designed with an extra amount of air storage internally that is used to assist in the purge cycle. An example is the **AD-IP™ EP** air dryer.

Several Bendix air dryers are available in specialized **"Drop-in"** versions designed especially for air systems that use either the Holset (Cummins) Type E or QE air compressor. These Holset compressors utilize an unusual unloading system that requires that air pressure remain in the discharge line during the entire unloaded cycle of the compressor. For example, the AD-IP™ "Drop-in" version is shown here.

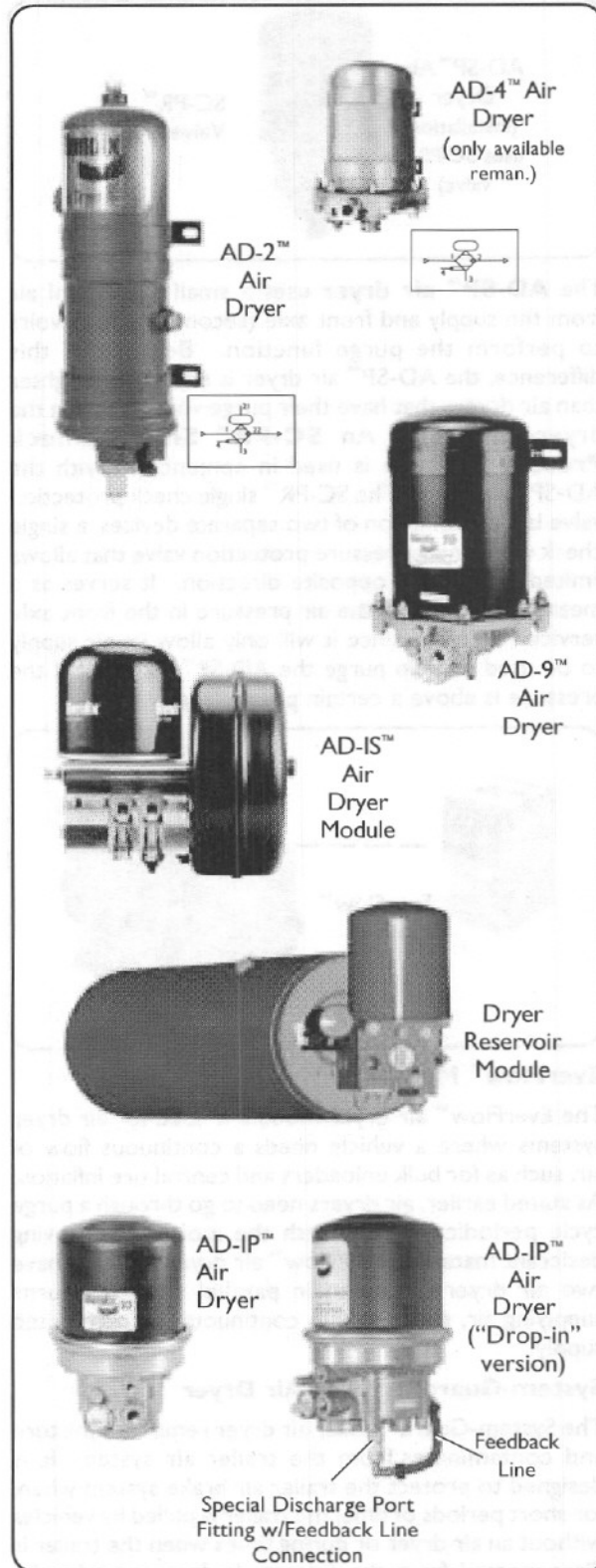

AD-SP™ Air
Dryer
(installation
uses SC-PR™
valve)



SC-PR™
Valve



The **AD-SP™** air dryer uses a small amount of air from the supply and front axle (secondary) reservoirs to perform the purge function. Because of this difference, the AD-SP™ air dryer is smaller and lighter than air dryers that have their purge volume within the dryer canister. An **SC-PR™ Single Check Protection Valve** is used in conjunction with the AD-SP™ air dryer. The SC-PR™ single check protection valve is a combination of two separate devices, a single check valve and a pressure protection valve that allows limited flow in the opposite direction. It serves as a means of protecting the air pressure in the front axle service reservoir, since it will only allow its air supply to be used to help purge the AD-SP™ air dryer if the pressure is above a certain preset level.

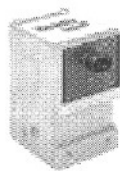

EverFlow™
Module

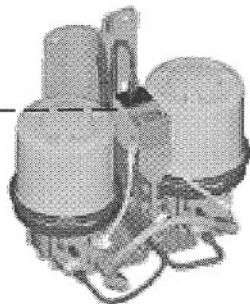

EverFlow™ Module

The EverFlow™ air dryer module is used for air dryer systems where a vehicle needs a continuous flow of air, such as for bulk unloaders and central tire inflation. As stated earlier, air dryers need to go through a purge cycle periodically to refresh the moisture-removing desiccant material. EverFlow™ air dryer modules have two air dryers plumbed in parallel that take turns supplying air, resulting in a continuous, uninterrupted supply.

System-Guard® Trailer Air Dryer

The System-Guard® trailer air dryer removes moisture and contaminants from the trailer air system. It is designed to protect the trailer air brake system when, for short periods of time, the trailer is pulled by vehicles without an air dryer or during times when the trailer is disconnected from the tractor. It does not take the

System-Guard®
Trailer Air
Dryer

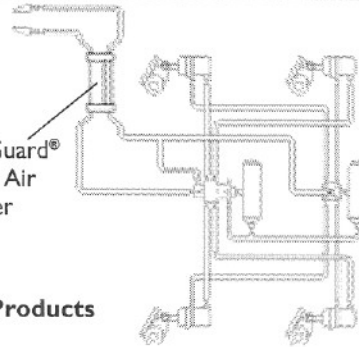

Trailer Products



Cyclone
DuraDrain™
Trailer Water
Separator



System-Guard® Trailer
Air Dryer



AF-3™
In-line Air Filter

place of a dryer normally located on the power unit, but acts as a buffer to remove moisture during wet times and gives up moisture during dry times.

PuraGuard®
system filter
(obsolete)



PuraGuard®
QC™ oil
coalescing
filter



PuraGuard® Filters

The PuraGuard® QC™ oil coalescing filter (and its predecessor PuraGuard® system filter) are for high air use vehicles such as transit buses and refuse trucks. Installed downstream of the air dryer, these filters use a replaceable filter element mounted within a sump housing to remove oil aerosols before they can enter the air system. A drain valve allows periodic maintenance.

Cyclone DuraDrain™ Trailer Water Separator

The Cyclone DuraDrain™ trailer water separator is installed in the trailer control and/or supply lines near the gladhands. It self-purges liquid contaminants, contains solid contaminants and improves the life of the trailer system components.

AF-3™ In-line Air Filter

The AF-3™ in-line air filter screens out foreign material from trailer air lines.

A **double check valve** is used in the air system when a single function or component must receive air from, or be controlled by, the higher of two sources of pressure. An internal disc or shuttle moves in response to the higher air pressure and allows that air source to flow out of the delivery port. It is recommended that double check valves be mounted so that the shuttle (or disc) operates horizontally.

While not strictly part of the charging system, the **DS-2™ double check valve and stop light switch** (shown on this page) performs the function of both a stop lamp switch and a double check valve. In some vehicle brake systems, it is used to detect air pressure from either brake circuit source, and will operate the stop lamp switch, lighting the stop lamps.

Auxiliary Systems

Vehicle auxiliary components and systems (air actuated wipers, suspension, etc.) requiring compressed air must wait until the reservoirs in the charging system have reached a predefined minimum pressure, sufficient for braking purposes. Once the system has reached the preset minimum, pressure protection valves open to supply auxiliary systems.

Pressure Protection Valves

The **pressure protection valve** is a normally-closed pressure sensitive control valve. These valves can be used in many different applications but are typically used to protect or isolate one reservoir from another, by closing automatically at a preset pressure. The valve is also commonly used to delay the filling of auxiliary reservoirs until a preset pressure is achieved in the primary or braking reservoirs. Pressure protection valves allow air to be "shared" between two reservoirs above the closing setting of the valve. The sharing ceases when pressure drops below the closing pressure of the valve and the reservoirs are then isolated from each other.

The **PR-2™ pressure protection valve** is externally adjustable, while the **PR-4™ pressure protection valve** (shown) has a fixed setting. Both valves are available in various factory preset pressure settings. The **PR-3™ pressure protection valve** differs from the two previously mentioned since its design includes a check valve preventing air return.

Pressure Reducing Valves

The **pressure reducing valve** is used in various applications where a constant set air pressure lower than supply pressure is required. A typical application is an air operated accessory that requires less than system pressure for operation. The **RV-1™ pressure**

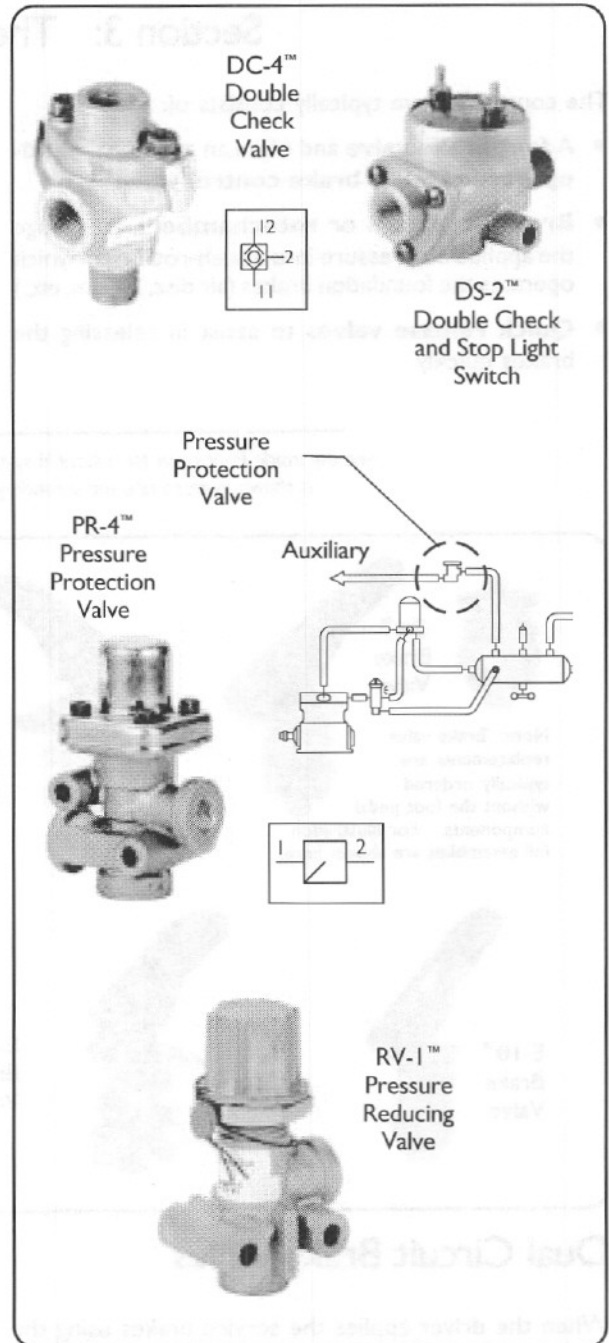

reducing valve (shown) is available in a wide range of pressure settings and can be manually adjusted. The **RV-3™ pressure reducing valve** is available with factory preset pressure settings only and cannot be manually adjusted.

Section 3: The Control System

The control system typically consists of:

- A **foot brake valve** and often an additional **hand-operated trailer brake control valve**
- **Brake actuators or rotochambers**, to change the applied air pressure into a push-rod force which operates the foundation brakes (air disc, S-Cam, etc.)
- **Quick release valves** to assist in releasing the brakes quickly
- Vehicle parking using **push-pull hand operated valves** and **spring brakes**,
- **Anti-compounding** system design to prevent both the service brakes and the parking brakes being applied at the same time, and
- **Proportioning valves** to adjust braking when a tractor is not pulling a trailer

See the inside front cover for a sample system schematic. The primary (rear) brake circuit is shown in green and the secondary (front) brake circuit is shown in orange.

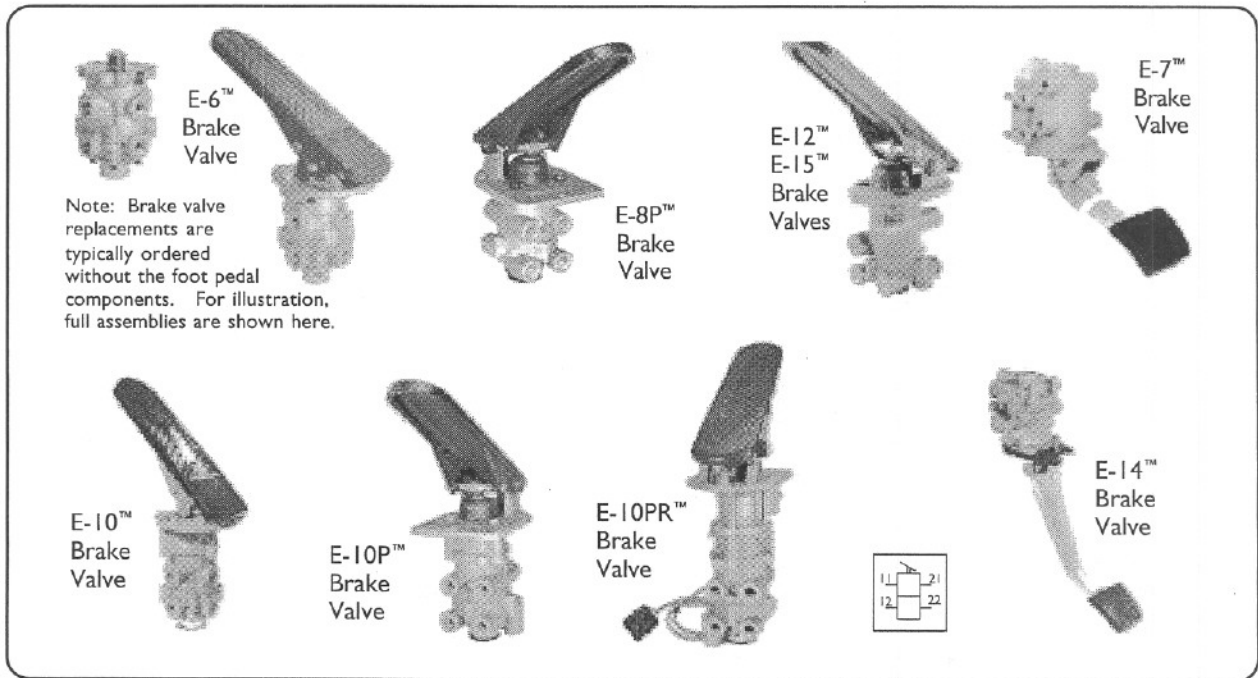

Dual Circuit Brake Valves

When the driver applies the service brakes using the brake pedal/treadle, a two-part plunger within the brake valve moves, closing the valve's exhaust and opening passages within the valve that allow the air pressure waiting there to pass through and be delivered to the rear and front brake systems. The pressure quickly increases in the brake chambers and applies force to the push rod, transferring the force to the S-Cam or air disc brake. Frictional forces slow the wheels and

the vehicle comes to a stop. When the driver removes all force from the brake valve the internal return springs move back to their original position and allow air in the valve and delivery lines to vent to atmosphere through the exhaust port.

The Bendix® E-6™, E-8P™, E-10™, E-10P™, E-12™ and E-15™ dual brake valves are typically **floor mounted** and treadle operated, while the Bendix® E-7™ and E-14™ dual brake valves are **bulkhead mounted**, suspended pedal valves.

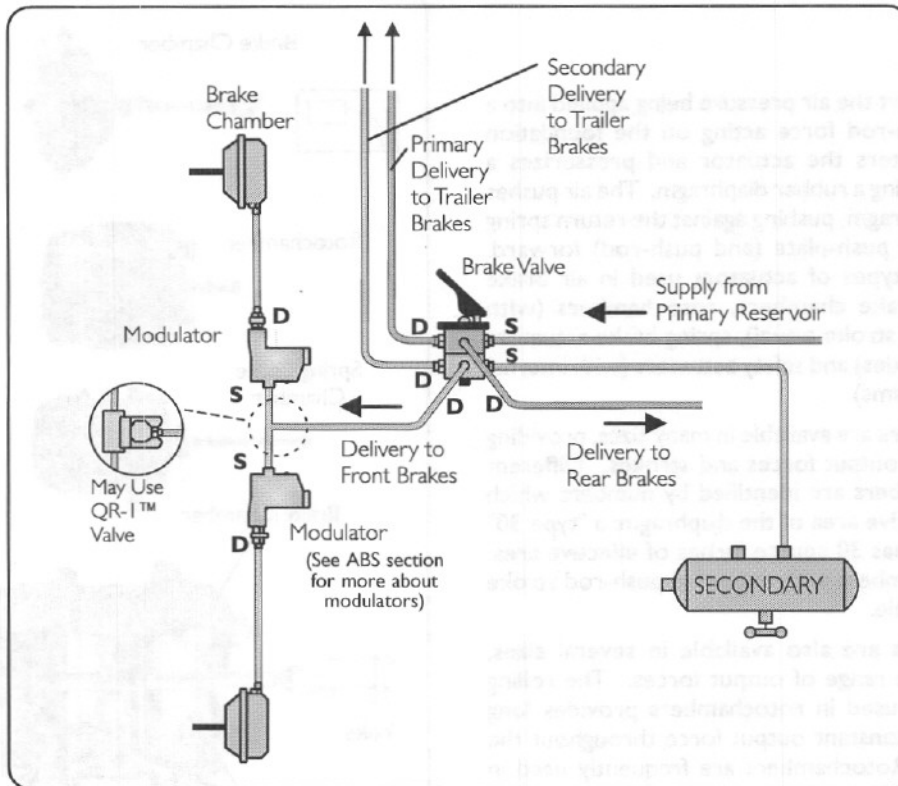

Mostly used in the transit (buses/coaches) industry, the **E-10PR™** retarder control brake valve has circuitry that is used to communicate with retarder systems installed on automatic transmission vehicles - extending the life of brake system components.

Hand-operated Brake Valves

For information on trailer control hand-operated valves, see page 29.

Vehicle Parking

For vehicle parking, rear brake actuators are designed with large internal springs that, when engaged, hold a parked vehicle in position. When the driver prepares to move away and releases the parking brake, the spring force is countered by the introduction of air pressure into a chamber within the spring brake portion of the actuator. A feature called anti-compounding helps prevent the application of both the spring and service brakes together.

Take Air Brake Training with the Experts

Bendix is proud to offer its Air Brake Training School.

The three-day training is tailored to both new and experienced technicians and provides students with valuable technical knowledge.

Beginning with the fundamentals of compressed air, classes cover the description, operation and service of major Bendix air brake components of dual air brake systems, as well as antilock braking.

To enroll, visit www.bendix.com and visit our training school pages to see the dates of classes offered in your area. Simply download and complete a registration form, or call 1-800-AIR-BRAKE (1-800-247-2725) and select option 5.

Actuators

Actuators convert the air pressure being applied into a mechanical push-rod force acting on the foundation brakes. Air enters the actuator and pressurizes a chamber containing a rubber diaphragm. The air pushes against the diaphragm, pushing against the return spring and moving the push-plate (and push-rod) forward. Some different types of actuators used in air brake systems are: brake chambers, rotochambers (with longer push-rod stroke travel), spring brake actuators (for rear brake axles) and safety actuators (with internal locking mechanisms).

Brake chambers are available in many sizes, providing a wide range of output forces and strokes. Different size brake chambers are identified by numbers which specify the effective area of the diaphragm: a "type 30" brake chamber has 30 square inches of effective area. Some brake chambers with extended push-rod stroke travel are available.

Rotochambers are also available in several sizes, providing a wide range of output forces. The rolling type diaphragm used in rotochambers provides long life and gives a constant output force throughout the entire stroke. Rotochambers are frequently used in industrial applications.

Spring brake actuators are composed of separate air and mechanical actuators in a single housing. Mounted at the wheel of the axle it serves, it functions as a service, parking and emergency brake. Connected to the service brake valve, the air applied portion of the actuator functions as the service brake. The mechanical portion of the actuator contains a powerful spring which is compressed by adding air pressure or released by removing air pressure. The spring brake therefore contains two actuators which use air pressure in opposite ways. The service actuator requires air pressure to apply the brakes, while the park or emergency actuator uses air pressure to release the brakes.

The **SB-1™ spring brake actuator** is a pull type, remote-mounted air cylinder that is used as a parking brake. Pressurized air in the chamber compresses the springs when the brake is released. When the air is exhausted, the spring force applies the brake.

The **SD-3™ roto safety actuator** is basically a rotochamber with mechanical roller locking mechanism similar to that of the DD3® actuator. The SD-3™ actuator is generally used on off-highway vehicles, and is piped in various ways to provide service, emergency,

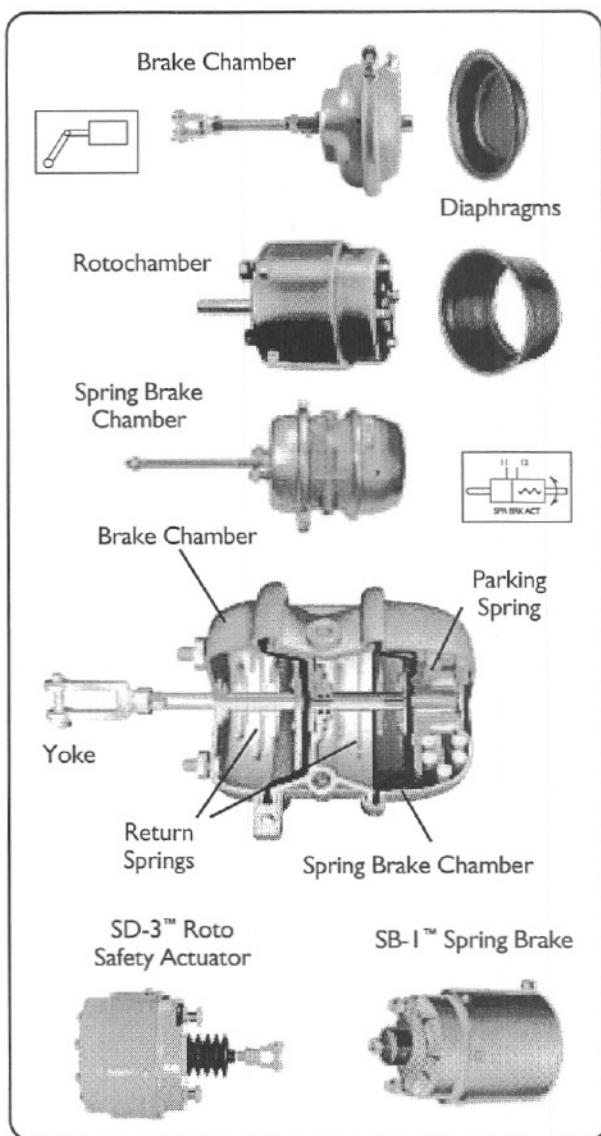

and parking brake functions. It is available in type 36 and 50 sizes.

Rarely used today, the **DD3® safety actuator** (not shown) was a dual diaphragm brake actuator with three functions; service braking, emergency braking and parking. The DD3® actuator featured a mechanical roller locking mechanism for parking and was used extensively on transit and innercity buses. Because of its unique locking roller mechanism, the DD3® actuator required the use of special control valves such as the TR-2™ inversion valve.

See page 54 for more about actuators.

Slack Adjusters

The slack adjuster is the link between a brake chamber or actuator and the S-Cam brake camshaft. Its arm is fastened to the push rod with a yoke and its spline is installed on the foundation brake cam shaft. It transforms and multiplies the force developed by the chamber into a torque which applies the brakes via the brake camshaft.

Manual Slack Adjusters

To compensate for the gradual wear on the brake block lining, slack adjusters are equipped with an adjusting mechanism, which provides a means of adjusting for brake lining wear. Slack adjuster models are designated by a number which represents its maximum torque rating (e.g. a type 20 unit is rated for a maximum of 20,000 inch-pounds of torque). Slack adjusters are available in various arm configurations, lengths and spline types.

The entire slack adjuster operates as a unit, rotating as a lever with the brake cam shaft as the brakes are applied or released. The most efficient braking action is obtained when the slack adjuster arm travel is approximately 90 degrees and in the recommended range of the chamber. Therefore, it is important that brake adjustments are made as often as necessary.

Automatic Slack Adjusters

Automatic slack adjusters perform the same function as the standard unit, except that it automatically adjusts for lining wear. The Bendix "sure stroke" unique design monitors brake lining to brake drum clearance, thus eliminating the possibility of over adjustment.

The automatic slack adjuster does not require periodic manual adjustment, however, the unit does provide for manual adjustment. All Bendix slack adjusters incorporate a grease fitting and/or a tapped hole for a lube fitting.

Ideal ASA-5™ Slack Adjuster Installation

The brake chamber push rod and arm of the slack adjuster should reach approximately 90 degrees at 1/2 the available stroke (mid-stroke) of the chamber. The chart to the right shows the ASA-5™ slack adjuster installation tolerance.

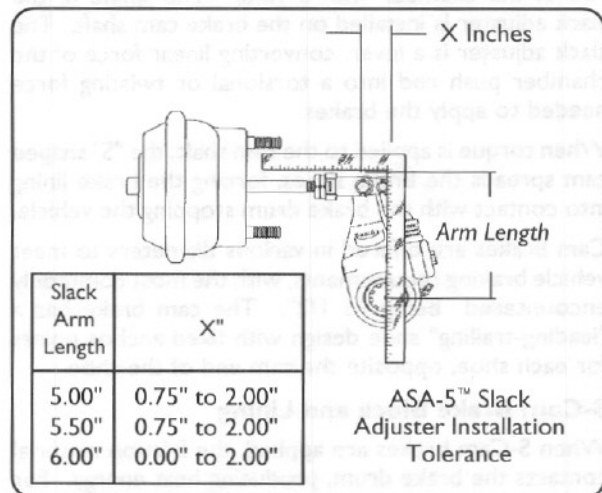
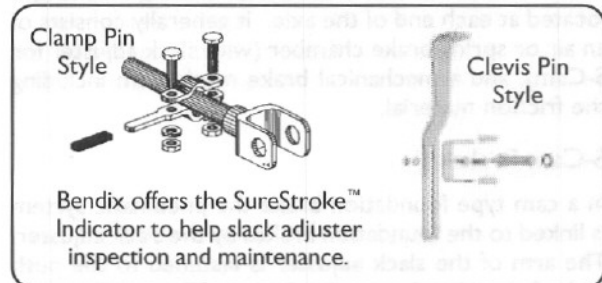
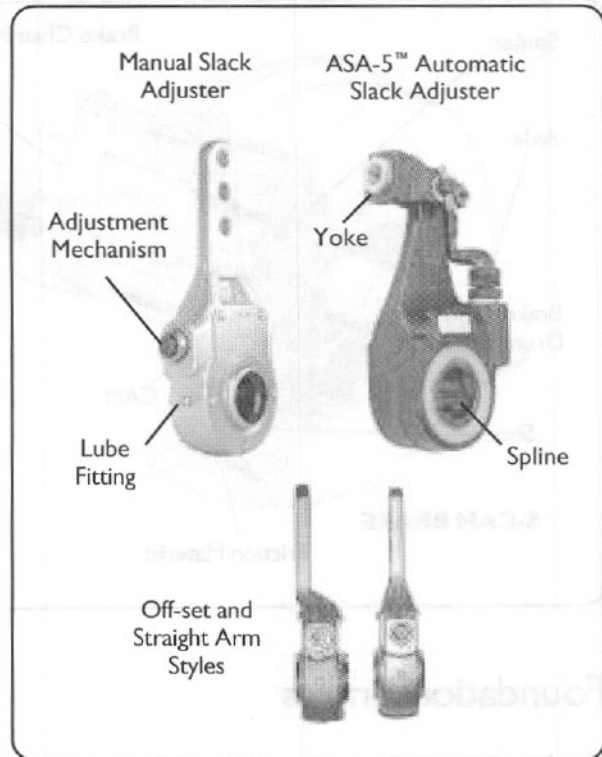

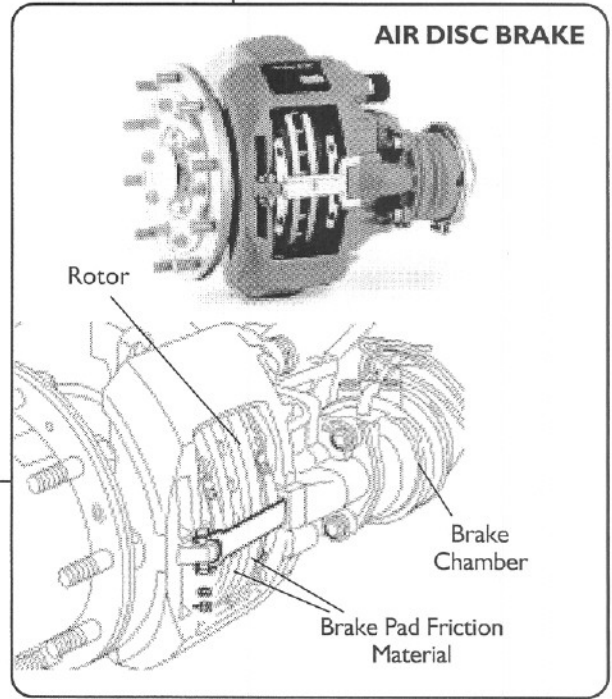
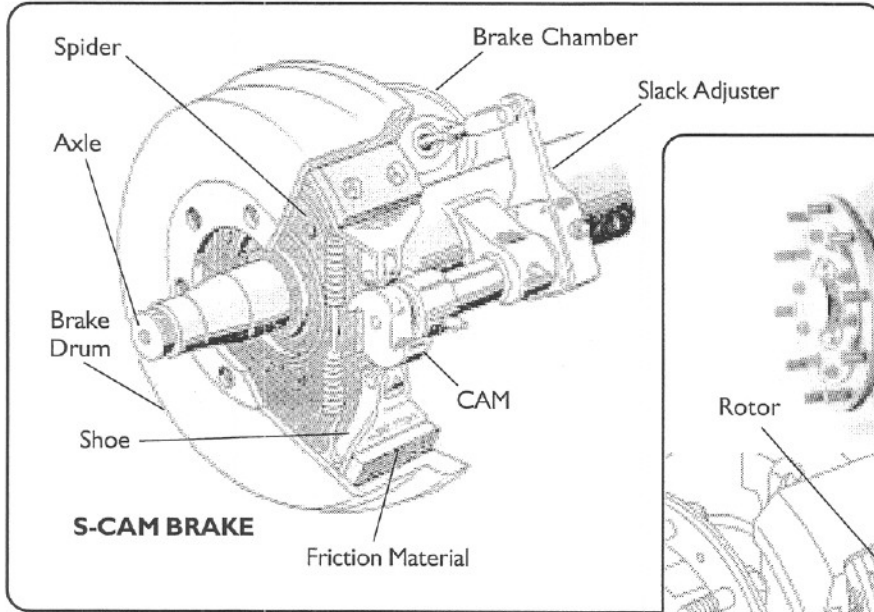

Foundation Brakes

The foundation brake is the actual braking mechanism located at each end of the axle. It generally consists of an air or spring brake chamber (with slack adjuster for S-Cam), and a mechanical brake mechanism including the friction material.

S-Cam Brakes

In a cam type foundation brake the pneumatic system is linked to the foundation brakes by the slack adjuster. The arm of the slack adjuster is fastened to the push rod of the chamber with a yoke. The spline of the slack adjuster is installed on the brake cam shaft. The slack adjuster is a lever, converting linear force of the chamber push rod into a torsional or twisting force needed to apply the brakes.

When torque is applied to the cam shaft, the "S" shaped cam spreads the brake shoes, forcing the brake lining into contact with the brake drum stopping the vehicle.

Cam brakes are offered in various diameters to meet vehicle braking requirements, with the most commonly encountered being 16 1/2". The cam brake has a "leading-trailing" shoe design with fixed anchor points for each shoe, opposite the cam end of the shoe.

S-Cam Brake Block and Lining

When S-Cam brakes are applied, the friction material contacts the brake drum, producing heat energy. For

optimal performance the heat that is generated must dissipate rapidly to prevent damage to the friction material. Therefore the friction material used in the brake must have the capability of withstanding the heat until dissipated through the drum. It takes the right combination of ingredients to formulate the friction material that provides all the desirable characteristics, including long life.

All friction material is identified by a stencil on its edge. This identification code consists of the name of the manufacturer, the formula identification and the friction class. The friction class is indicated by two letters. The first letter represents the normal coefficient of friction, and the second represents the hot coefficient of friction. The numerical range is shown on page 20.

Friction material selection is dependent upon how the driver uses the brakes, the terrain, vehicle load, etc. The various formulations of material are designed to meet the needs of these conditions. For example, a vehicle performing heavy duty operations on rugged terrain may benefit by using a "premium" material designed for high heat situations instead of a "standard" material designed for lighter duty operations.

Brake lining and block differ in that it takes two brake blocks to line one shoe while a single brake lining segment is all that is required to do the same job. Block is generally 3/4" thick and used on class 8 vehicles while lining is 1/2" thick and generally used on smaller vehicles.

While it is recommended that a matching set of lining be used on each wheel, under some conditions a combination of different lining materials may be desirable. If a brake system is marginal, for example, a full step up to a higher grade lining may give an excessively large capacity. In this event using a combination of blocks should be considered.

Brake Block

Brake Lining

FRICITION CODE CHART

Letter	Numerical Range
D	over 0.150, but less than 0.250
E	0.250 to 0.350
F	0.351 to 0.450
G	0.451 to 0.550
H	Over 0.550

The friction class is indicated by two letters (e.g. DF). The first letter represents the normal coefficient of friction, and the second represents the hot coefficient of friction.

Air Disc Brakes

Bendix air disc brakes are a "floating caliper" design for use as a foundation brake on all axles of heavy commercial vehicles and trailers. In terms of performance and ease of service, Bendix air disc brakes compared favorably to traditional S-Cam brakes. They are available in models with or without a combination spring brake chamber. Optional wear sensors and wear diagnostic equipment are available on some models.

Bendix air disc brakes convert air pressure into braking force. When the foot brake is applied, air from the vehicle brake system enters the service brake chamber through the supply port, applying pressure to the diaphragm. The pressure pushes the diaphragm, moving the pressure plate and pushrod against a cup in the lever. The lever pivots on an eccentric bearing and transfers motion to the actuating beam. Moving against return spring force, the actuating beam moves two threaded tubes and tappets, which force the inner brake pad into contact with the brake rotor. Further movement of the actuating beam forces the caliper, sliding on two stationary guide pins, away from the rotor, which pulls the outer brake pad into the rotor. The clamping action of the brake pads on the rotor applies braking force to the wheel.

Releasing the foot brake releases pressure in the service brake chamber. With no pressure in the service brake chamber, return springs force the air disc brakes into a neutral, non-braked position. The non-braked position is mechanically controlled by a brake adjuster mechanism in the caliper. The caliper contains a brake

Air Disc Brake Cut-away View

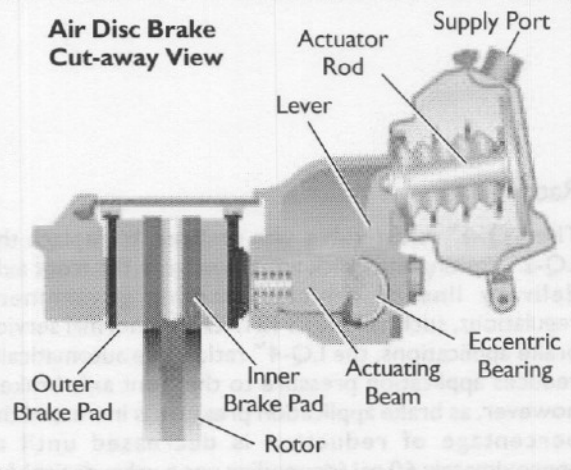

adjuster mechanism that turns threaded tubes to set a gap (running clearance) between the rotor and the brake pads. When operated manually with the adjuster shaft, the adjuster mechanism sets the system's non-braked position. The adjuster mechanism also operates automatically, whenever the brakes are activated, to compensate for rotor and brake pad wear and keep the running clearance constant.

The rotor-friction couple is carefully designed for optimal performance and durability. It is recommended that only approved replacement disc pads or rotors be used to prevent damage to disc brake components (e.g. cracked rotors) or premature or uneven pad wear, which can adversely affect braking performance.

Quick Release Valves

The function of the **quick release valve** is to speed up the exhaust of air from the air chambers. It is mounted close to the chambers it serves. In its standard configuration, the valve is designed to deliver within one psi of control pressure to the controlled device; however, for special applications the valve is available with greater differential pressure designed into the valve.

Several styles of quick release valves are available and are functionally the same. The **QRV™ quick release valve** is the oldest design and utilizes a die cast metal body with an internal diaphragm, spring and spring seat. The **QR-1™ quick release valve** also has a die cast body and diaphragm, but does not employ a spring or spring seat. The (non-serviceable) **QRN-2™ quick release valve** is a nonmetallic version of the **QR-1™ quick release valve**. The **QR-L™ quick release valve** is an inline device.

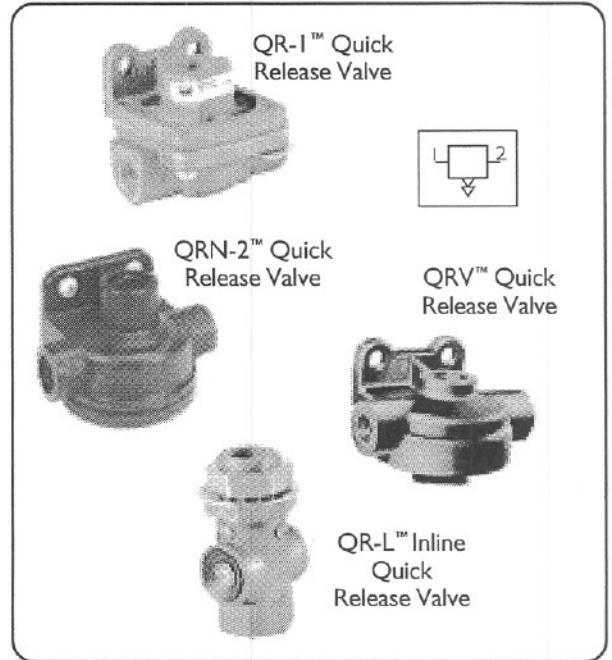

Ratio Valves

The **LQ-4™ ratio valve** was designed to replace the LQ-2™ limiting and quick release valve in the front axle delivery line of vehicles meeting government regulations, such as FMVSS 121. During normal service brake applications, the LQ-4™ ratio valve automatically reduces application pressure to the front axle brakes, however, as brake application pressure is increased the percentage of reduction is decreased until at approximately 60 psi (depending upon valve design) full

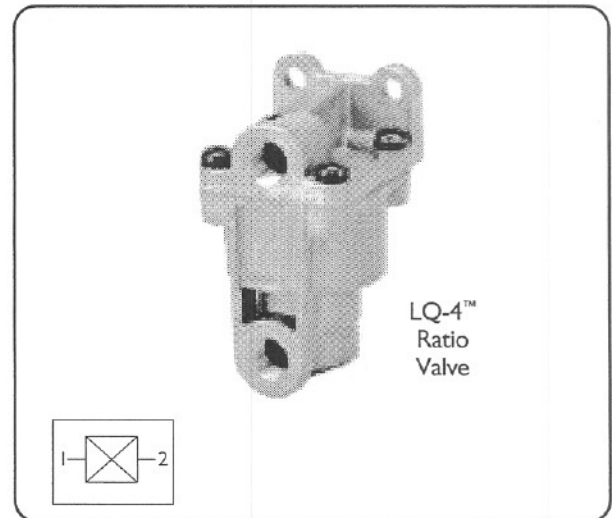
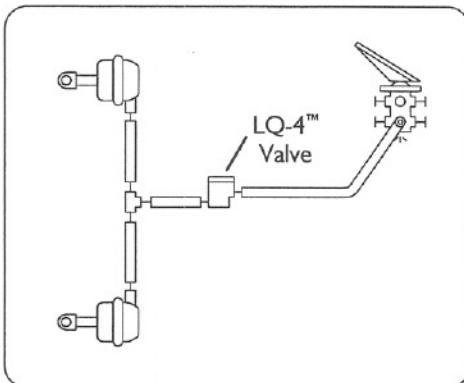

pressure is delivered. The valve is available with several different "hold-off" pressures which prevent the front brakes from operating until the "hold-off" pressure is exceeded.

The obsolete LQ-3™ ratio valve appears identical to the LQ-4™ ratio valve with minor differences in porting size.

Bobtail Ratio Valves

The **LQ-5™ bobtail ratio valve** is used on the front (steering) axle of tractor air brake systems to reduce brake application pressure during normal tractor-trailer operation. During bobtail mode (when the tractor is not pulling a trailer), tractor braking performance is improved because the LQ-5™ bobtail ratio valve delivers full brake pressure to the steering axle.

The LQ-5™ bobtail ratio valve is designed for tractor systems only, and it replaces the existing front axle limiting valve.

Air Brake Proportioning Valves

The **BP-1™ brake proportioning valves** are incorporated into the air systems to improve the controllability and reduce the stopping distance of bobtail operated tractors during braking. The TR-3™ valve senses the lack of trailer supply line pressure during bobtail operation, and controls the BP-1™ FRONT and REAR valves. The BP-1™ FRONT valve reduces application pressure to the front brakes during tractor trailer operation and returns to full application pressure during bobtail operation. The BP-1™ REAR valve delivers full pressure during tractor trailer operation and reduces application pressure during bobtail operation. Treadle application force, during bobtail operation, resembles treadle application force, during tractor operation with a loaded trailer.

Both the BP-1™ FRONT and REAR valve are identical in appearance to the LQ-5™ valve, however they are not interchangeable. A metal tag identifies the BP-1™ valve.

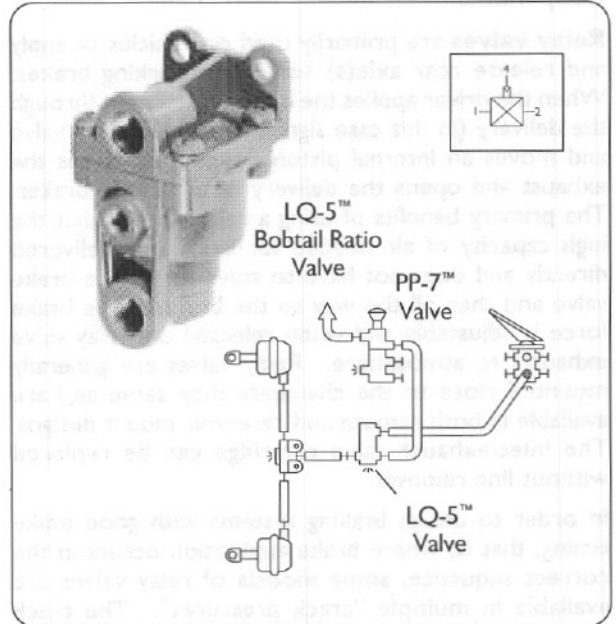

Brake Proportioning Relay Valves

The **BP-RI™ bobtail proportioning relay valve** is a combination of two valves in a single housing. The lower portion contains a "standard" service brake relay valve, which functions as a relay station to speed up brake application and release. The upper portion houses a brake proportioning valve which reduces normal service brake application pressure when the tractor is not towing a trailer (bobtail operation). The control port on the BP-RI™ valve is connected to the trailer supply valve delivery and signals bobtail operation.

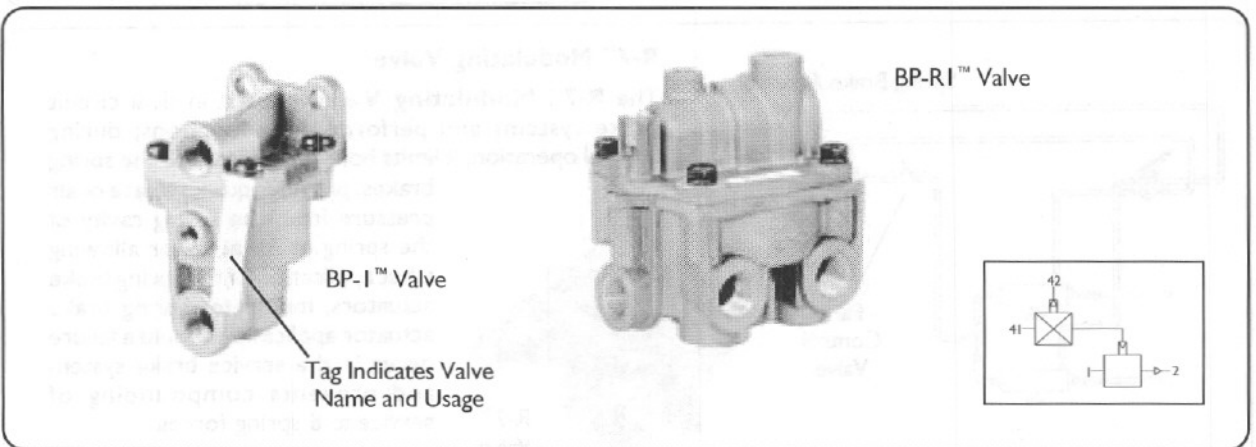

Relay Valves

Relay valves are primarily used on vehicles to apply and release rear axle(s) service or parking brakes. When the driver applies the brakes, air travels through the delivery (in this case signal) line to the relay valve and moves an internal piston down. This closes the exhaust and opens the delivery of air to the brakes. The primary benefits of using a relay valve is that the high capacity of air needed for braking is delivered directly and does not have to travel up to the brake valve and then all the way to the brakes. The brake force is adjustable and when released the relay valve exhausts to atmosphere. Relay valves are generally mounted close to the chambers they serve and are available in both remote and reservoir mount designs. The inlet/exhaust valve cartridge can be replaced without line removal.

In order to design braking systems with good brake timing, that is, where brake application occurs in the correct sequence, some models of relay valves are available in multiple "crack pressures". The crack pressure value for a particular valve is varied by the use of different strength return springs within the valve which the air pressure signal must overcome before air begins to be delivered to the brake chambers.

The **R-8™** and **R-14™** relay valves both incorporate an integral double check valve with a balance port connection which provides both an anti-compounding or quick exhaust feature depending upon vehicle application. The anti-compound feature is used when these valves are used to control spring actuated parking features.

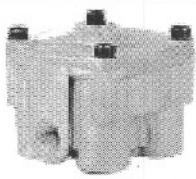

**R-12™
Relay Valve**



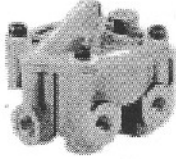

**R-12P™
Relay Valve**
(0 crack pressure for long wheelbase trailers and dollies)

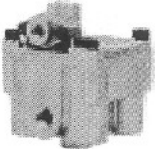

**R-12DC™
Relay Valve**
(Straight trucks)

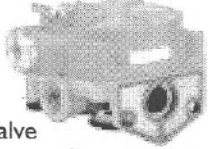

**R-8™
Relay Valve**
(Anti-compounding, frame or reservoir mounted)

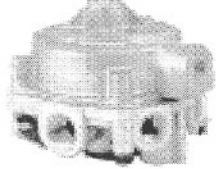

**R-8P™
Relay Valve**
(0 crack pressure for long wheelbase trailers and dollies)

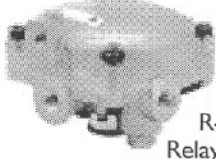

**R-6™
Relay Valve**

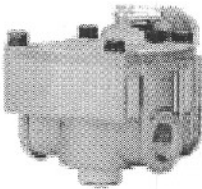

**R-14™
Relay Valve**
(Anti-compounding)



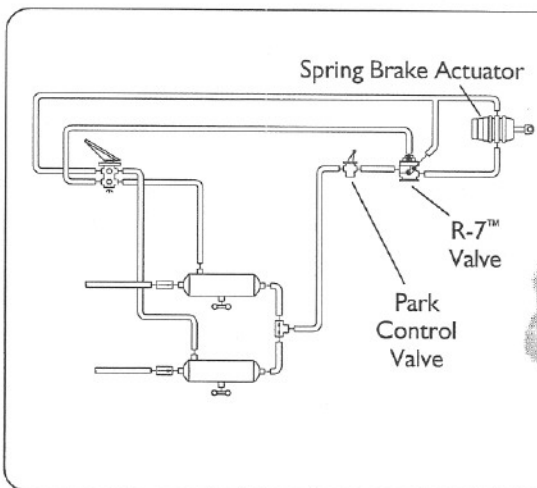

R-7™ Modulating Valve

The **R-7™ Modulating Valve** is used in dual circuit brake systems and performs four functions; during normal operation, it limits hold-off pressure to the spring brakes, provides quick release of air pressure from the spring cavity of the spring brake actuator allowing a fast application of the spring brake actuators, modulates spring brake actuator application should a failure occur in the service brake system and prevents compounding of service and spring forces.

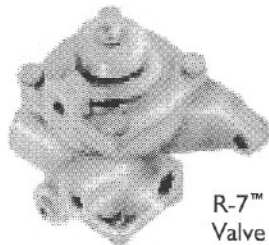

Push-Pull Control Valves

Push-pull control valves are most often mounted on the vehicle dash board and are used for a variety of control applications. The PP-1™ and PP-2™ valves are pressure sensitive, normally closed, on/off control valves which automatically return to the exhaust (button out) position when supply pressure is below the required minimum. They may be manually operated to either position when pressure is above the required minimum. Pressure settings and button configuration and wording may vary, depending on application.

The **PP-1™ control valve** is commonly used to control parking and emergency brakes. This valve was also used in conjunction with the TP-2™ tractor protection valve in pre-FMVSS 121 single circuit tractor air systems.

Unlike most other push-pull control valves, the **PP-8™** is nonautomatic, and will remain in the applied (button in) position regardless of delivery or supply pressure. The PP-8™ control valve is commonly used to control the tractor brakes only in the (FMVSS 121-compliant) dual system.

The **PP-3™ control valve** is primarily used to control the TP-3™ tractor protection valve in pre-FMVSS 121 tractor systems. It features a tripper piston which prevents manual override of the emergency application of trailer brakes.

Trailer Supply Valve (Tractor Protection Control)

The **PP-7™ push-pull control valve** is a pressure sensitive, on/off control valve which will automatically return to the exhaust (button out) position when supply pressure is below the required minimum. It may be

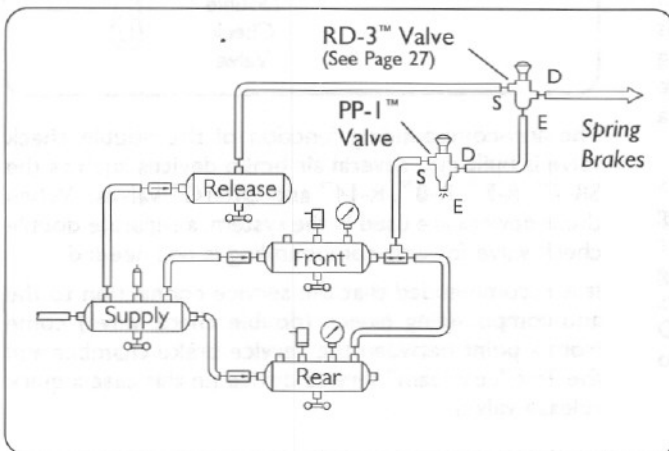
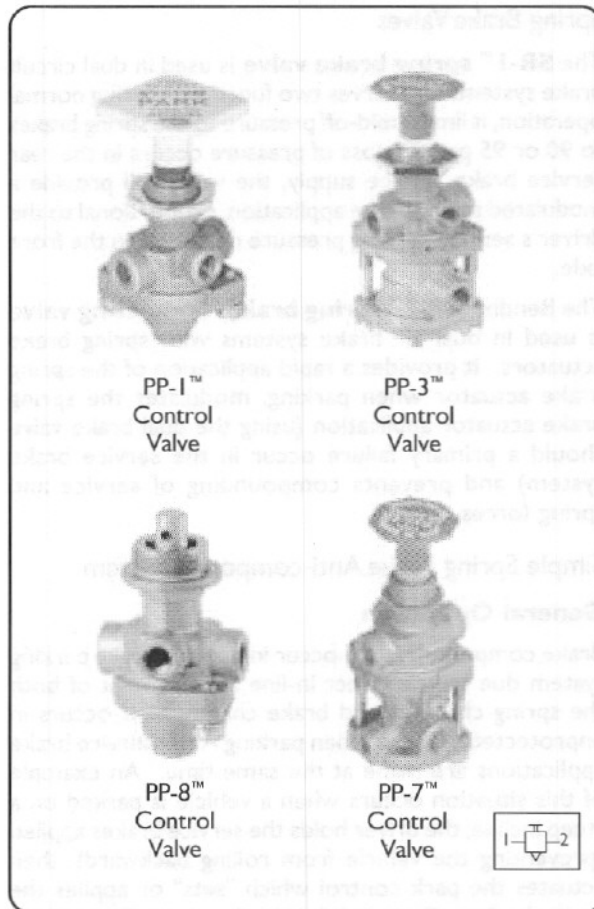

manually operated to either position when pressure is above the required minimum. Button configuration and wording may vary depending on application. The automatic exhaust pressure is 40 psi.

The PP-7™ valve is used to control the tractor protection system and is generally identified as the trailer air supply valve. The valve employs an air operated interlock in the lower body which will apply the trailer brakes when the tractor spring applied parking brakes are applied. The interlock insures that the tractor parking brake can not be applied without the trailer parking brakes also being applied. Normally this action will not affect the position of the PP-7™ valve button. The interlock of tractor and trailer parking is a requirement of government regulations (e.g. FMVSS 121).

Spring Brake Valves

The **SR-1™ spring brake valve** is used in dual circuit brake systems and serves two functions; during normal operation, it limits hold-off pressure to the spring brakes to 90 or 95 psi. If a loss of pressure occurs in the rear service brake service supply, the valve will provide a modulated spring brake application, proportional to the driver's service braking pressure delivered to the front axle.

The Bendix® **SR-7™ spring brake modulating valve** is used in dual air brake systems with spring brake actuators. It provides a rapid application of the spring brake actuator when parking, modulates the spring brake actuator application (using the dual brake valve should a primary failure occur in the service brake system) and prevents compounding of service and spring forces.

Simple Spring Brake Anti-compound System

General Operation

Brake compounding can occur in a spring brake parking system due to the direct in-line arrangement of both the spring chamber and brake chamber. It occurs in unprotected systems when parking AND service brake applications are made at the same time. An example of this situation occurs when a vehicle is parked on a steep incline; the driver holds the service brakes applied (preventing the vehicle from rolling backward), then actuates the park control which "sets" or applies the spring brakes. For a brief time, the air applied service brakes and the mechanical spring brakes both exert a braking force on the slack adjusters and foundation brakes. The forces of the spring and air applications are additive and can cause damage to the foundation brake components (cam shaft splines, shoes, drum, etc.) and/or slack adjuster. An anti-compounding system is especially important in protecting the adjusting mechanism of automatic slack adjusters from damage caused by over-torque that occurs during a compounded application of the brakes.

Anti-compounding prevents the simultaneous application of both the air and spring brakes by directing application air to the spring brakes when both are applied at once. In the simple anti-compounding schematic shown here, the double check valve allows service application air to apply the service brakes AND move into the spring cavity if they are also applied (no air pressure and springs are also applying brakes).

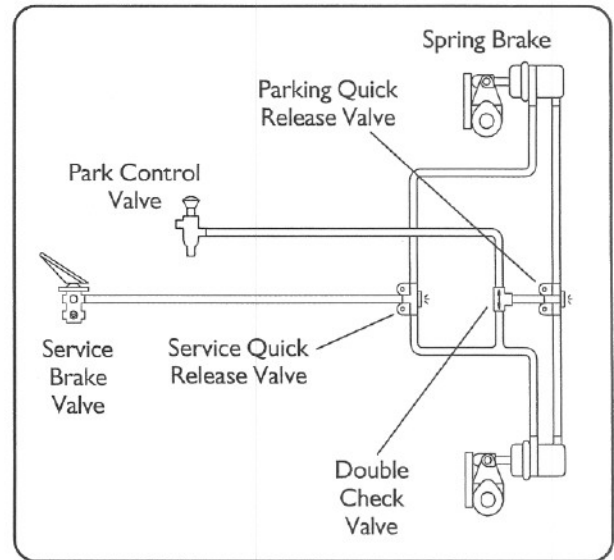
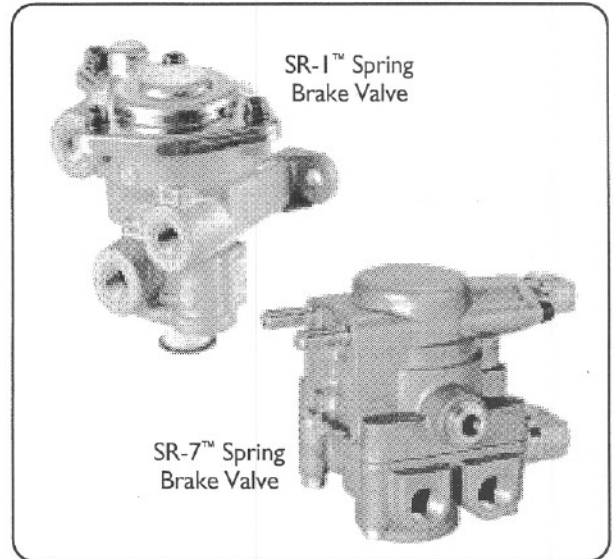

The anti-compounding function of the double check valve is built into several air brake devices such as the SR-7™, R-7™, R-8™, R-14™ and QR-1C™ valves. When these devices are used in the system, a separate double check valve for anti-compounding is not needed.

It is recommended that the service connection to the anti-compounding device (double check valve) come from a point between the service brake chamber and the first "upstream" service device (in this case a quick release valve).

Lever Operated Control Valves

The TW-2™ and TH-3™ valves are identical in appearance (and similar to the TW-1™, TW-3™ and TW-4™) except they have two control valves housed in a single body. These two valves differ by the internal cammed control lever, which for the TW-2™ control valve has two lever positions, while the TH-3™ valve has three.

The TW-1™, TW-3™ and TW-6™ series control valves are manually operated, non-modulating (on - off) control valves used in a wide variety of control functions. The TW-1™ and TW-3™ are dash-mounted, lever-controlled valves.

The TW-4™ is a manually operated momentary non-modulating control valve commonly used in conjunction with air starter systems.

A momentary push-type control valve, the TW-5™ will deliver air pressure when the plunger is pushed in and exhaust delivered air when the plunger load is released. A typical application is for control of a differential lock-out.

Stop Lamp Switches

The SL-4™ and SL-5™ stop lamp switches are pressure-sensitive electro-pneumatic switches installed in the service application system. They operate the vehicle stop lamps by completing an electrical circuit and lighting the stop lamps each time a brake application is made.

See page 14 for the DS-2™ double check and stop light switch.

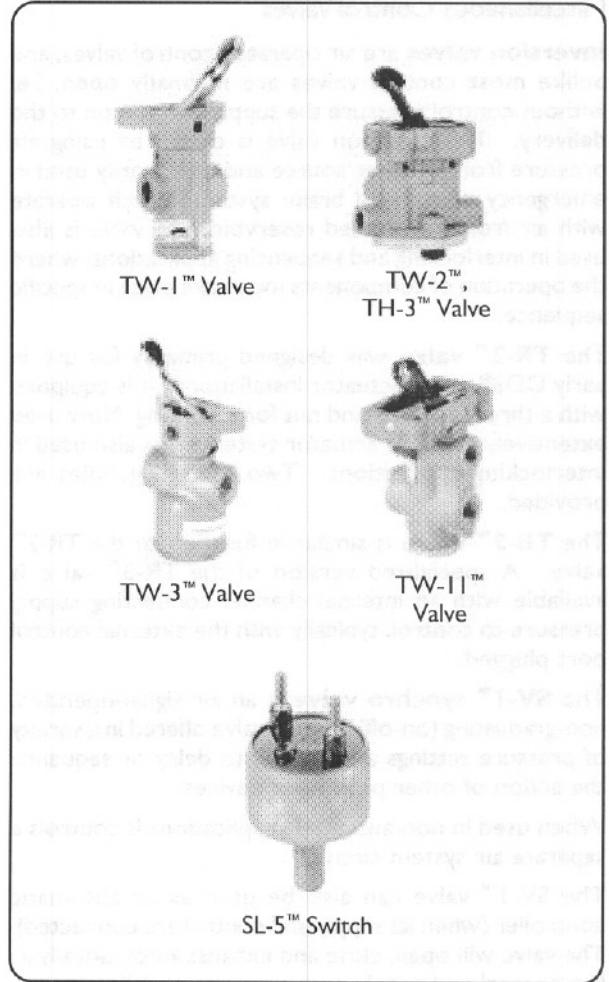

Dual Function Quick Release Valve

The QR-1C™ valve has a dual function. It works as a quick release valve for rapid park brake actuation and also provides anti-compounding, since its double check valve prevents simultaneous service and emergency spring brake applications.

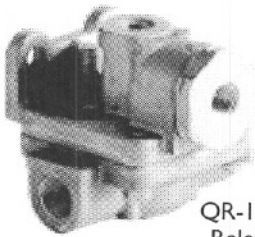

QR-1C™ Quick Release Valve

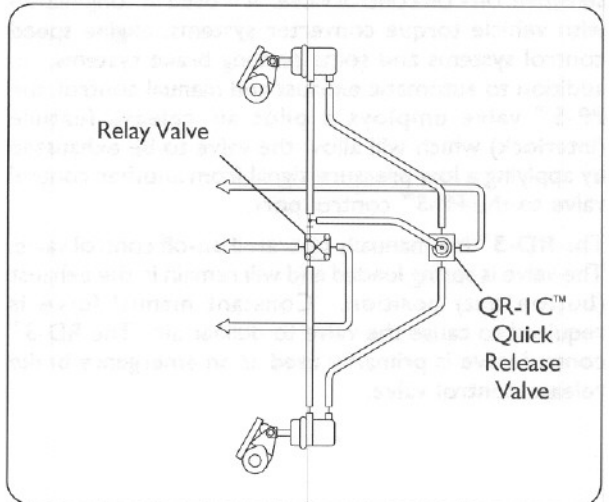
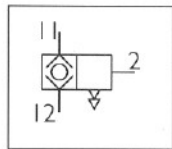

Miscellaneous Control Valves

Inversion valves are air operated control valves, and unlike most control valves are normally open, i.e. without control pressure the supply is common to the delivery. The inversion valve is closed by using air pressure from another source and is primarily used in emergency or parking brake systems which operate with air from an isolated reservoir. The valve is also used in interlocking and sequencing applications, where the operation of components must take place in specific sequence.

The **TR-2™ valve** was designed primarily for use in early DD3® safety actuator installations. It is equipped with a threaded body and nut for mounting. Now used extensively in DD3® actuator systems, it is also used in interlocking applications. Two mounting holes are provided.

The **TR-3™ valve** is similar in function to the TR-2™ valve. A specialized version of the TR-3™ valve is available with an internal channel connecting supply pressure to control, typically with the external control port plugged.

The **SV-1™ synchro valve** is an air signal-operated, non-graduating (on-off) control valve offered in a variety of pressure settings and is used to delay or sequence the action of other pneumatic devices.

When used in non-automatic applications it controls a separate air system circuit.

The SV-1™ valve can also be used as an automatic controller (when its supply and control are connected). The valve will open, close and exhaust automatically as the control and supply pressures rise or fall.

The **PP-5™ push pull control valve** is a pressure sensitive, on - off control valve. It is used in conjunction with vehicle torque converter systems, engine speed control systems and some parking brake systems. In addition to automatic exhaust and manual control, the PP-5™ valve employs a pilot air release feature (interlock) which will allow the valve to be exhausted by applying a low pressure signal from another control valve to the PP-5™ control port.

The **RD-3™** is a manually operated on-off control valve. The valve is spring loaded and will remain in the exhaust (button out) position. Constant manual force is required to cause the valve to deliver air. The RD-3™ control valve is primarily used as an emergency brake release control valve.

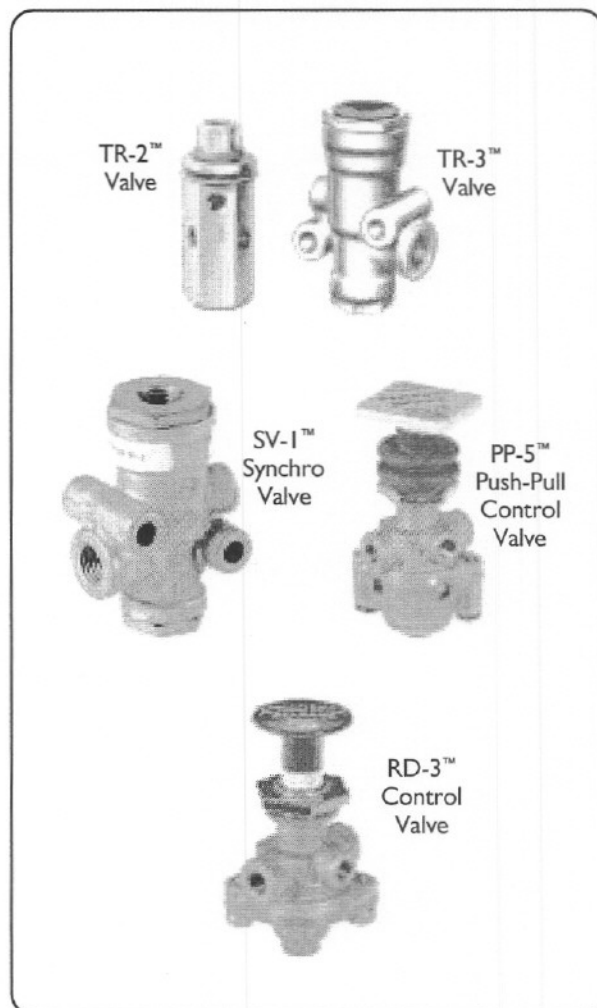

Section 4: Tractor Parking, Trailer Charging/Parking and Emergency Systems

The tractor/trailer parking and emergency system typically consists of:

- The tractor parking control system
- The trailer parking and emergency system, and
- The tractor protection system

See the inside front cover for system schematic. The primary (rear) brake circuit is shown in green and the secondary (front) brake circuit is shown in orange.

Park Control Valves

The **PP-DC™** park control double check valve is a push-pull, manually operable on/off valve with an integral double check. It is dashboard mounted and provides in-cab control of truck or bus parking brakes. Manually pushing or pulling the button will release or apply the parking brakes. The integral double check valve allows the PP-DC™ valve to receive supply air pressure from either, or both, the front or rear axle service reservoirs. The valve is pressure sensitive and automatically moves from the applied (over the road position) to the exhaust position (thus applying the parking brakes) if total system pressure (both front and rear axle reservoirs) drops below 20 to 30 psi.

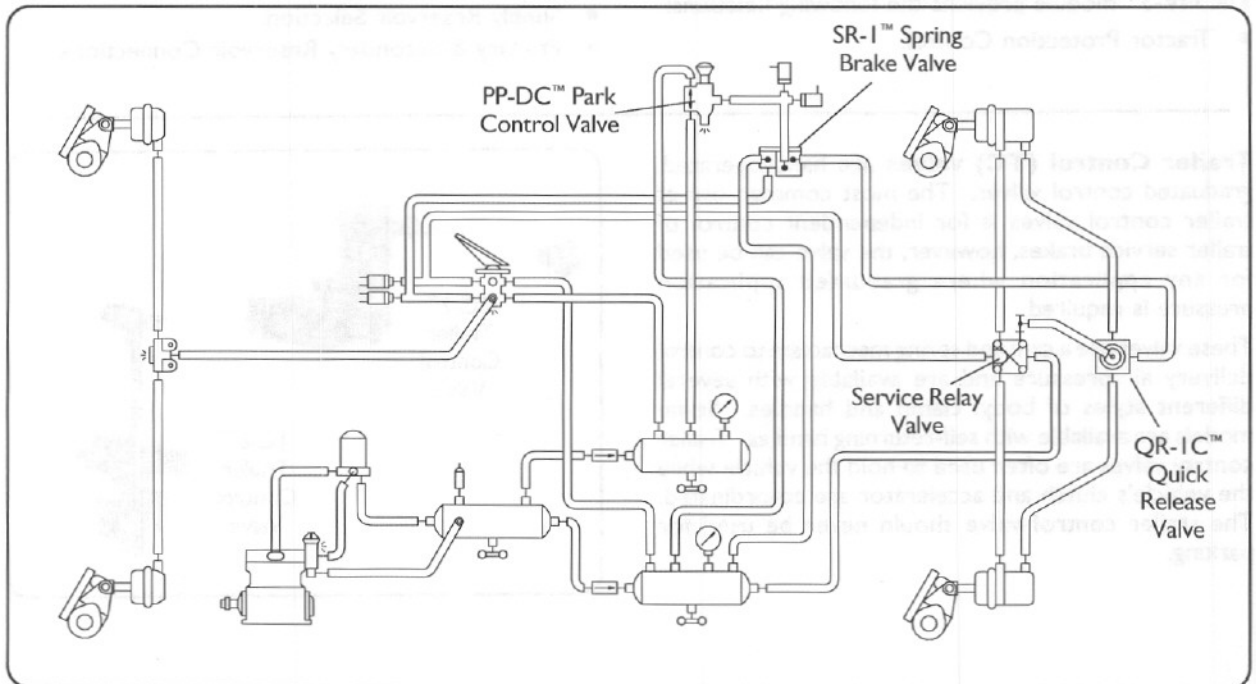
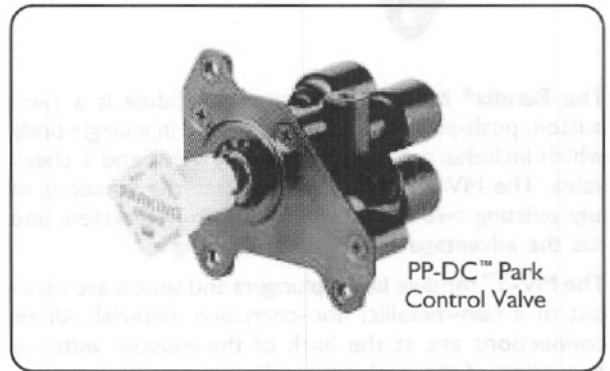

The **MV-3™ dash control module** combines the functions of a PP-1™ control valve and a PP-7™ trailer supply valve together into a unified device.

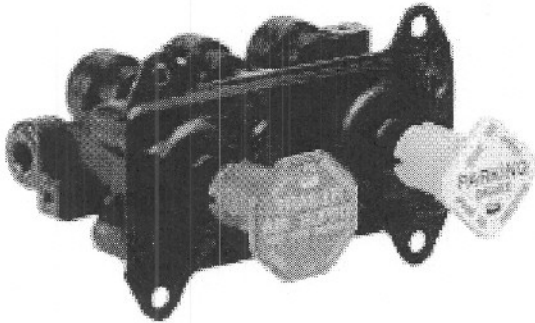

The Bendix® MV-3™ dash control module is a two-button, push-pull control valve housed in a single body which includes a dual circuit supply valve and a check valve. The MV-3™ valve can duplicate the functions of any existing two or three valve push-pull system and has the advantage of reduced plumbing.

The MV-3™ module body, plungers and spools are made out of a non-metallic, non-corrosive material. All air connections are at the back of the module with the exception of the optional auxiliary port.

The MV-3™ module provides the following functions:

- Tractor Protection Control.

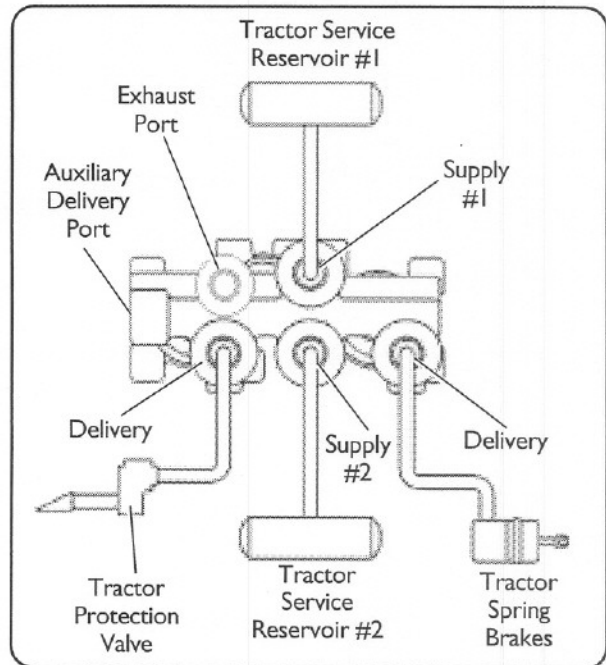

- System Park.
- Trailer Park Only.
- Trailer Charge with Tractor Spring Brakes Applied (Tractor Park Only).
- Supply Reservoir Selection.
- Primary & Secondary Reservoir Connections.

Trailer Control (TC) valves are hand-operated, graduated control valves. The most common use of trailer control valves is for independent control of trailer service brakes, however, the valve can be used for any application where graduated application pressure is required.

These valves use a cam and spring mechanism to control delivery air pressure and are available with several different styles of body, clamp and handles. Some models are available with self-returning handles. Trailer control valves are often used to hold the vehicle while the vehicle's clutch and accelerator are co-ordinated. The trailer control valve should never be used for parking.

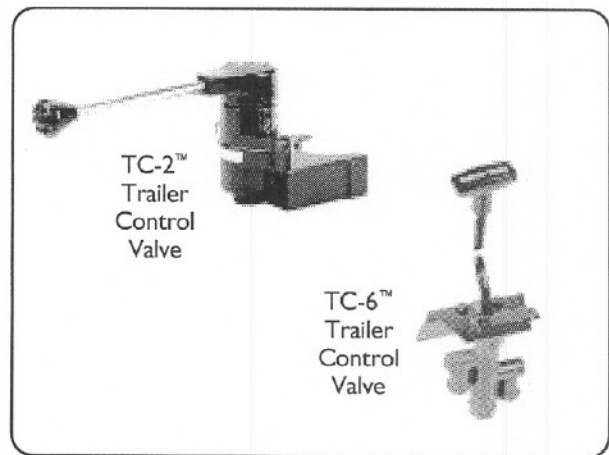

Tractor Protection Valves

The primary function of tractor protection valves (e.g. the **TP-3™ tractor protection valve**) is to protect the tractor air brake system under trailer breakaway conditions and/or conditions where severe air leakage develops in the tractor or trailer. In addition, in everyday use, the valve is used to shut off the trailer service and supply lines before disconnecting the tractor from the trailer. The valve is usually mounted at the rear of the tractor cab and a dash mounted control valve.

The **TP-3DC™ tractor protection valve** integrates the functions of the TP-3™ valve and one double check valve. A stop light switch port is provided and is connected to the delivery of the internal double check valve. It also has an internal single check valve that prevents air pressure from being trapped in the trailer service line, which prevents brake compounding and minimizes roll away conditions.

The **TP-4™ and TP-5™ tractor protection valves** are designed to incorporate several pneumatic control functions within a common housing, thereby eliminating considerable interconnection piping.

These include a combination of two double check valves and a tractor protection valve. With these valves, either brake circuit on the vehicle can be used to apply the trailer brakes. In addition, when used in conjunction



with a control valve, it opens and closes the trailer service and supply lines in the same manner as a tractor protection valve. The valves also incorporate porting for the installation of the service stop lamp switch.

The TP-4™ tractor protection valve, used solely on Ford "L" model tractors, incorporates porting for a front axle limiting control on pre-FMVSS 121 vehicles.

The TP-5™ tractor protection valve also incorporates a quick release valve for the trailer service line.

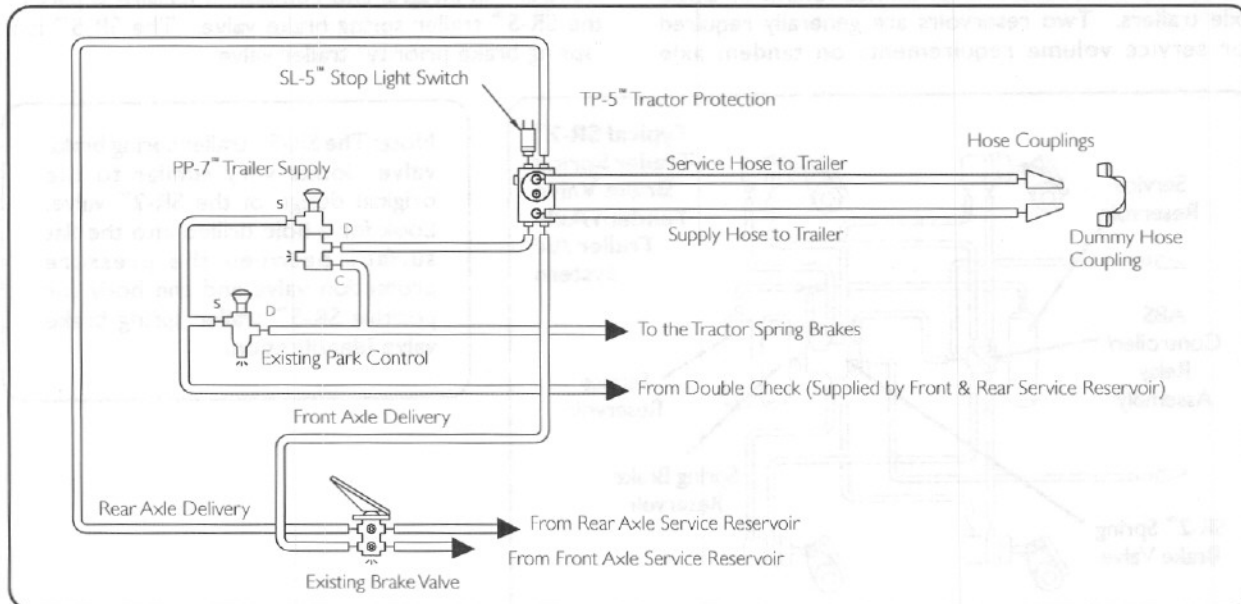

Trailer Spring Brake Valves

Trailer spring brake valves are designed for use in trailer air brake systems.

The SR-4™ trailer spring brake valve was an earlier design that used a dedicated spring brake reservoir for release of the trailer spring brakes. Note: This valve is available for service only, due to changes made in FMVSS 121 (superceded by SR-5™). All other Bendix spring brake valves use service reservoir air for trailer spring brake release.

Mounted on one of the trailer reservoirs, these valves control both the parking and emergency brake functions of the spring brakes and use internal pressure protection and check valves to isolate reservoir failures to prevent automatic application of the trailer spring brakes. An anti-compound feature is part of these valves.

With later government regulations allowing simplified system plumbing, Bendix developed the SR-5™ trailer spring brake valve. It also mounts to a reservoir on the trailer and, like the SR-2™ & SR-4™ trailer spring brake valves, it controls the trailer spring brakes, but unlike these valves, the SR-5™ trailer spring brake valve uses supply line pressure to release the trailer spring brakes. Because dedicated or isolated reservoir pressure is no longer required by law for spring brake release, the SR-5™ trailer spring brake valve system needs only a one reservoir for service volume on single axle trailers. Two reservoirs are generally required for service volume requirements on tandem axle

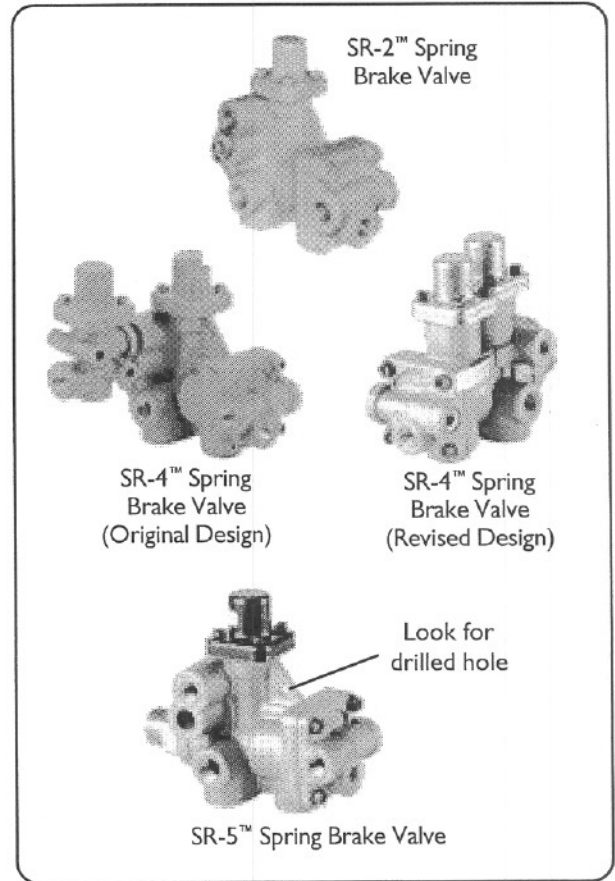

trailers. An integral anti-compound feature is part of the SR-5™ trailer spring brake valve. The SR-5™ is a "spring brake priority" trailer valve.

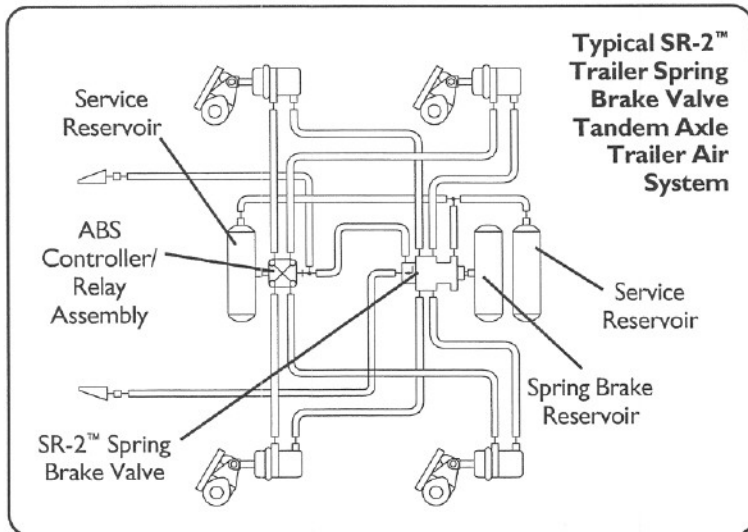

Note: The SR-5™ trailer spring brake valve looks very similar to the original design of the SR-2™ valve. Look for a hole drilled into the flat surface between the pressure protection valve and the body for positive SR-5™ trailer spring brake valve identification.

**Typical SR-5™
Trailer Spring
Brake Valve
Tandem Axle
Trailer Air
System**

(Note simplified
system plumbing)

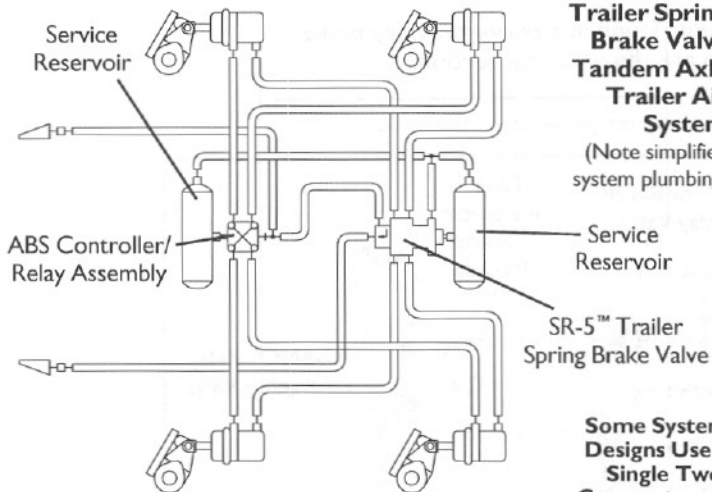

**Some System
Designs Use a
Single Two-
Compartment
Reservoir**

The **TE-1™ trailer emergency stop light switch** is a pressure-sensitive switch to operate the stop lights in the event of emergency trailer brake application.

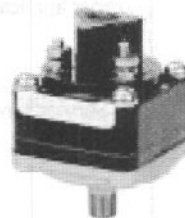

The **TR-5™ lock line control valve** is a specialized, pilot operated, non-automatic, on - off control valve, designed primarily for use in off-highway parking and emergency brake systems. It is almost identical in appearance to the SV-1™ control valve. Unlike the SV-1™ control valve, the TR-5™ control valve reacts to control pressure from two different sources and does not have an exhaust.

The **PE-4™ control valve** is most often used as the control for off highway emergency/park brake systems. It is essentially a variation of the TH-3™ valve which incorporates two TW-1™ type valves in a single body. A common air supply is provided for the two valves and a single, cammed lever is used which has three operating positions and "Z" shift pattern.

TR-5™
Control
Valve



PE-4™
Control
Valve



Section 5: Converter Dolly Brakes

Typical components found in a converter dolly brake system are shown in this section.

See the inside front page for full system schematic.

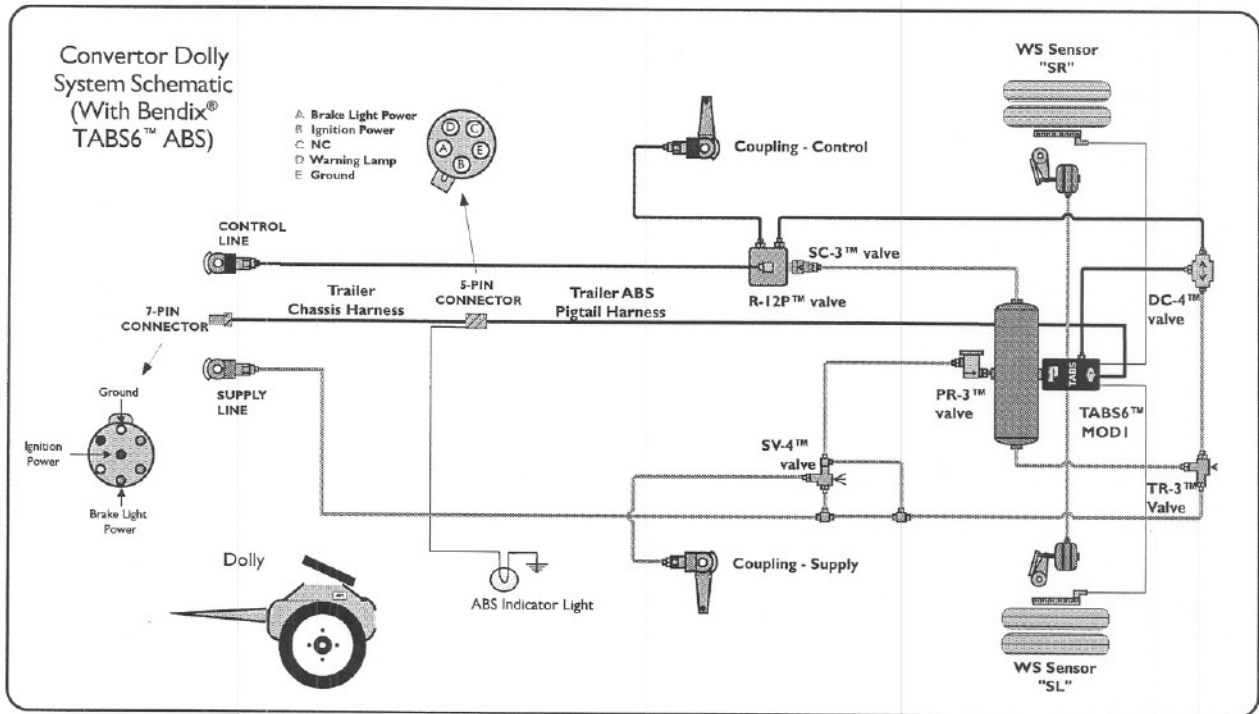
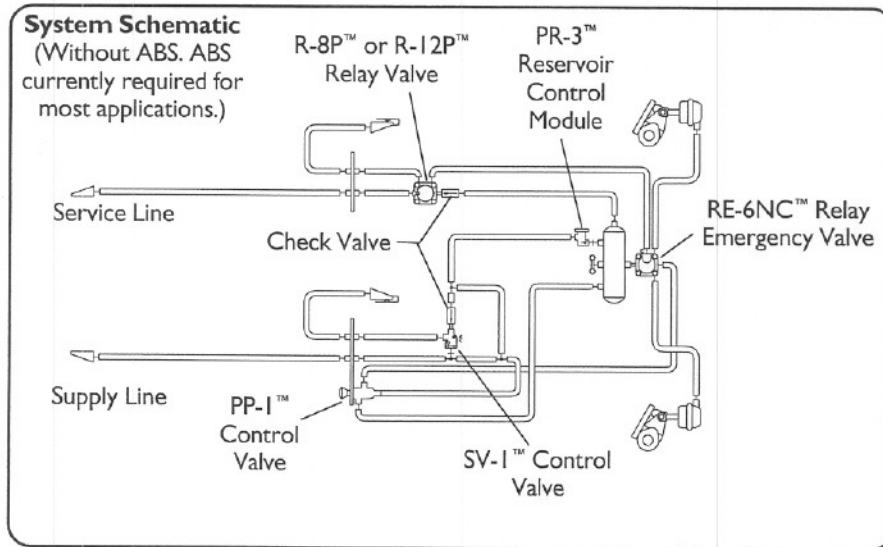

Typical Converter Dolly Components

The **R-8P™** and **R-12P™** pilot relay valves are special purpose relays designed specifically for use on trailers and converter dollies. These 0 p.s.i. crack and differential relays speed up brake application signals to provide an equal or balanced pressure signal to all trailer and dolly brakes on double and triple trailer combinations. By maintaining the same application signal across the entire train of trailers these pilot operated relay valves aid in achieving overall vehicle brake balance and stability.

The **SV-1™** synchro valve is a remote mounted air operated, ON-OFF control valve. It is used to control air from a remote supply, has a set opening and closing pressure and can be used to delay or sequence the action of other pneumatic devices. Use of the SV-1™ valve in dolly or towing trailer system prevents automatic application of the towing (lead) trailer or dolly emergency brakes in the event a breakaway occurs with the towed (rear) trailer. The **SV-4™** synchro valves work similarly to the SV-1™ synchro valves, and are used on trailer converter dollies to minimize the possibility of false charging.

The **RE-6NC™** relay emergency (non-charging) valve is used in Dolly Systems and replaces the conventional RE-6™ valve. The RE-6NC™ valve is similar to the RE-6™ valve but is designed to prevent direct filling of the dolly reservoir through the RE-6NC™ valve. It is generally used in conjunction with the PR-3™ pressure protection and single check valve to provide rapid dolly brake release.

The **PR-3™** reservoir control valve is the combination of a PR-4™ pressure protection valve and a single check valve. This valve may be used in a variety of applications, however the most common is in the converter dolly brake system where it functions to delay filling of the reservoir until pressure in the supply air line exceeds 75 psi and to prevent pressure loss due to a failure in the trailer being towed.

The **PP-1™** control valve is commonly mounted to the frame and used as a brake release valve. Pushing in the PP-1™ valve releases the dolly's parking brake and allows it to be moved. Since the dolly uses its own supply air to park, once it's moved, pulling out the PP-1™ valve button re-parks the dolly.

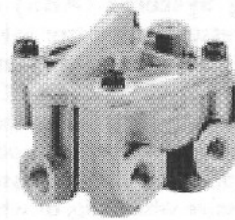

R-12P™
Relay Valve

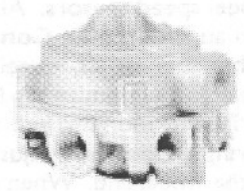

R-8P™
Relay Valve



SV-1™
Synchro Valve

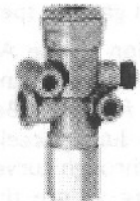

SV-4™ Trailer
Release
Valve

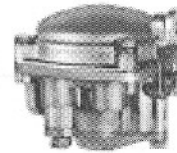

RE-6NC™ Relay
Emergency Valve

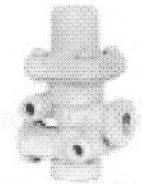

PR-3™ Reservoir
Control Valve



PP-1™
Control
Valve

Converter Dolly systems also widely use DC-4™ double-check valves (see page 14), and TR-3™ inversion valves (see page 27).

Section 6: Antilock Braking Systems

Bendix® **Antilock Braking Systems (ABS)** use wheel speed sensors, ABS pressure modulator valves, and an **Electronic Control Unit (ECU)** to control either four or six wheels of a vehicle. Bendix ECUs are able to optimize slip between the tire and the road surface by monitoring individual wheel turning motion during braking, and adjust or pulse the brake pressure at the wheel end. When excessive wheel slip, or wheel lock-up, is detected, the ECU will activate the Pressure Modulator Valves similar to a driver pumping the brakes. The ECU, however, is able to pump the brakes on individual wheels (or pairs of wheels), independently, and with greater speed and accuracy than a driver.

In addition to the ABS function, premium models of the ECUs provide an **Automatic Traction Control (ATC)** feature. Bendix ATC can improve vehicle traction during acceleration, and lateral stability while driving through curves. ATC utilizes **Engine Torque Limiting** where the ECU communicates with the engine's controller and/or **Differential Braking** where individual wheel brake applications are used to improve vehicle traction.

Premium ECUs have a drag torque control feature which reduces driven-axle wheel slip (due to driveline inertia) by communicating with the engine's controller and increasing the engine torque.

Electronic Stability Program (ESP)

Recent Bendix ABS advances include ESP® functionality which has the ability to apply brakes to individual wheel ends, and the trailer, to counteract the trailer "push" during maneuvers that may lead to loss of control or jackknives on low to high friction surfaces (snow, rain, asphalt, concrete, etc.)

Roll Stability Program (RSP)

The Bendix Roll Stability Program (RSP), is an all-axle ABS solution that helps reduce vehicle speed by applying all vehicle brakes as needed, reducing the tendency to roll over. RSP focuses on reducing the vehicle's speed below the critical roll threshold during direction-changing maneuvers such as exit ramps and obstacle avoidance on dry, high friction surfaces.

Trailer ABS

See page 42 for more information on trailer ABS systems and components.

ABS Components

Typical ABS components (for trucks and tractors) are:

- Wheel speed sensors (such as the Bendix® WS-24™ wheel speed sensors shown on this page). Each sensor is installed with a Bendix Sensor Clamping Sleeve. Vehicles have an exciter ring (or "tone ring") as part of the wheel assembly, and as the wheel turns, the teeth of the exciter ring pass the wheel speed sensor, generating an alternating current (AC) signal, which varies in voltage and frequency as the wheel speed changes. The ECU receives the AC signal and can then monitor how fast the wheel is turning.
- Pressure Modulator Valves (PMV) (such as the Bendix® M-32™ or M-32QR™ pressure modulator valves - shown on this page). PMVs use solenoids with the ability to apply, hold, or release the air pressure being delivered to the brakes to optimize brake performance. Four, five, or six of these valves may be used depending on ECU model and vehicle configuration.

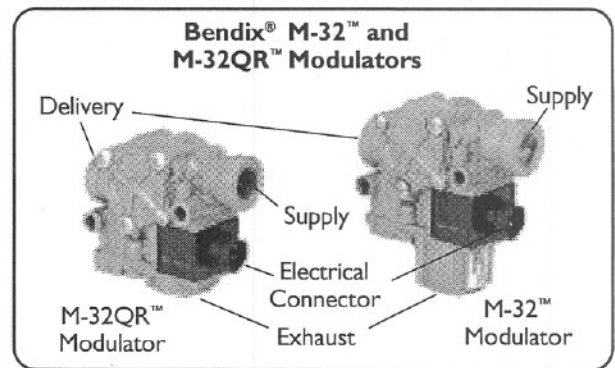
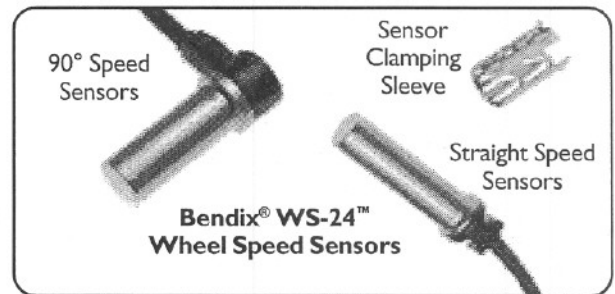

ABS Components continued ...

- Dash-mounted tractor ABS Indicator Lamp
- Service brake relay valve
- Dash-mounted trailer ABS Indicator Lamp (used on all towing vehicles manufactured after March 1, 2001)
- Optional blink code activation switch
- Optional ABS off-road switch. (Off-road feature is not typically available on all models)

Some "Premium" Bendix ABS systems utilize additional components, such as traction control valves, a dash-mounted ATC status/indicator lamp, serial communication to the engine control module, a stop lamp switch input, and optional ATC off-road switch.

With advanced ABS, the roll stability and ESP features require additional components including vehicle sensors to detect vehicle motion (lateral and yaw-rate sensors, and pressure sensors for load estimation) and driver intention (by monitoring the turning of the steering wheel).

All Bendix ECUs feature digital electronics with self test and diagnostic circuitry that continuously monitors operation of the entire antilock system including wiring continuity. A history of all diagnostic trouble codes are stored in the controller's memory and are not cleared by loss of power to the unit.

ECU controllers are typically available in frame-mounted and cab-mounted models.

Truck and Tractor ABS Operation

As described in the introduction to this section, Bendix ABS uses wheel speed sensors, modulator valves, and an ECU. By monitoring individual wheel turning motion during braking, the ECU is able to optimize slip between the tire and the road surface by pumping the brakes on individual wheels (or pairs of wheels), independently.

Steer Axle Control

Although both wheels of the steer axle have their own wheel speed sensor and pressure modulator valve, the ECU blends the applied braking force between the two steering axle brakes. A Bendix patented brake application control, called Modified Individual Regulation (MIR), has been designed to help reduce steering wheel pull during an ABS event on road surfaces with poor traction (or areas of poor traction, e.g. asphalt road surfaces with patches of ice).

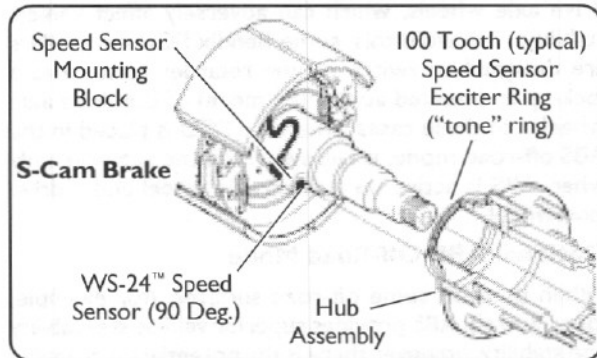

Vehicle Configurations

Depending on the number of drive axles, various numbers of sensors and modulators may be used for an ABS system. For example, a 4 sensor/4 modulator (4S/4M) system would typically be used for a single drive axle vehicle. System configurations are available for 4S/4M, 6S/6M, and 6S/5M (with the additional axle, a non-driven rear axle, having two sensors, but only one pressure modulator valve). In the case of a 6S/5M arrangement, the PMV controls both wheels on the additional axle. The additional axle wheels would receive equal brake pressure, based on the wheel that is currently experiencing the most wheel slip.

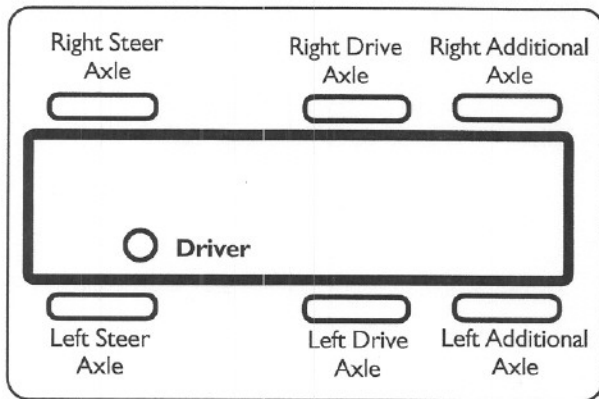

Normal Braking

During normal braking, air brake pressure is delivered through the ABS PMV and into the brake chamber. If the ECU does not detect excessive wheel slip, it will not activate ABS control, and the vehicle stops with normal braking.

Retarder Brake System Control

On surfaces with low traction, application of the retarder can lead to high levels of wheel slip at the drive axle wheels, which can adversely affect vehicle stability. To avoid this, some Bendix ECU controllers are designed to switch off the retarder as soon as a lock-up is detected at one (or more) of the drive axle wheels. In these cases, when the ECU is placed in the ABS off-road mode, it will switch off the retarder only when ABS is active on a steer axle wheel and a drive axle wheel.

Optional ABS Off-Road Mode

When used on some off-road surfaces, (for example, loose gravel), ABS provides superior vehicle steerability and stability, however there is the potential for stopping distances to be longer than without ABS. This is because locked-up wheels on gravel, etc. tend to plow up the road surface in front of the tires.

Bendix Premium ECUs have an optional ABS off-road control mode that more effectively accommodates these soft road conditions and shortens stopping distances while maintaining optimal vehicle steerability and stability. Care must be taken, however, not to use the ABS off-road mode on normal, paved road surfaces (since vehicle stability and steerability may be reduced), so the ABS Indicator Lamp flashes to show the driver that the ABS off-road mode is being used.

All-Wheel Drive (AWD) Vehicles

AWD vehicles with an engaged interaxle differential (steer axle to rear axle)/AWD transfer case may have negative effects on ABS performance. Optimum ABS performance is achieved when the lockable differentials are disengaged, allowing individual wheel control.

Premium ECUs can be programmed specifically for this configuration to control the differential lock/unlock solenoid in the AWD transfer case. When programmed to do so, the ECU will disengage the locked interaxle/AWD transfer case during an ABS event and reengage it once the ABS event has ended.

ATC Operation

ATC Functional Overview

Just as ABS improves vehicle stability during braking, ABS systems with ATC improve vehicle stability and traction during vehicle acceleration. The ATC function uses the same wheel speed information and modulator control as the ABS function. The ECU detects excessive drive wheel speed, compares the speed of the front, non-driven wheels, and reacts to help bring the wheel spin under control. The ECU can be configured to use engine torque limiting and/or differential braking to control wheel spin. For optimal ATC performance, both methods are recommended.

Differential Braking

Differential braking is automatically activated when drive wheel(s) on one side of the vehicle are spinning, which typically occur on asphalt road surfaces with patches of ice. The traction system will then lightly apply the brake to the drive wheel(s) that are spinning. The vehicle differential will then drive the wheels on the other side of the vehicle. Differential braking is available at vehicle speeds up to 25 MPH.

STRAIGHT TRUCK WITH STANDARD ABS SYSTEM SCHEMATIC (ABS COMPONENTS HIGHLIGHTED)

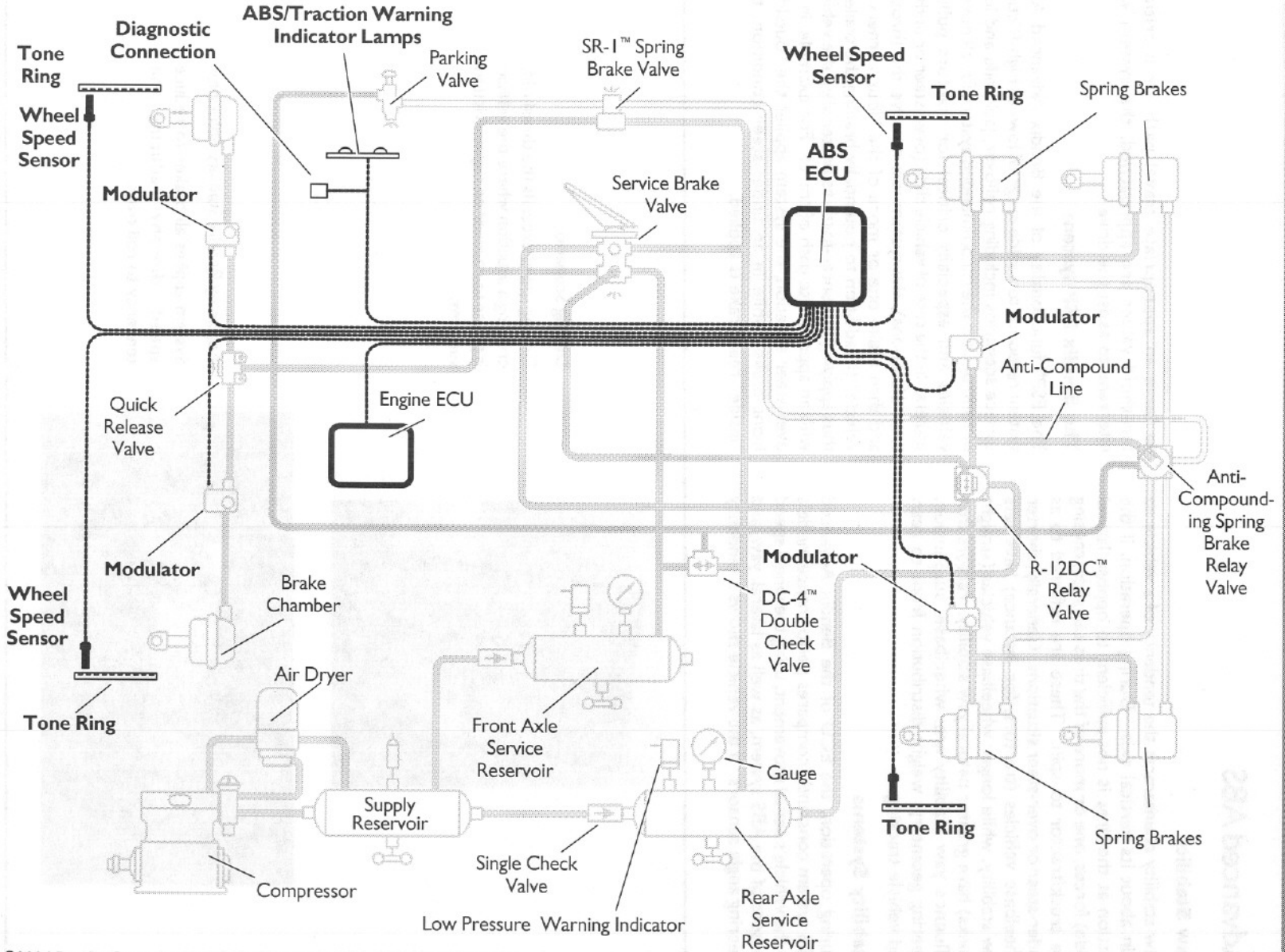

www.bendix.com 1-800-AIR-BRAKE (1-800-247-2725)

Advanced ABS

Yaw Stability

Yaw stability counteracts the tendency of a vehicle to spin about its vertical axis. During operation, if the friction at the tires is not sufficient to oppose lateral (side) forces, one or more of the tires can slide, causing the truck/tractor to spin. These are referred to as under-steer or over-steer situations. Generally, shorter wheelbase vehicles (tractors, for instance) have less yaw stability, while longer wheelbase vehicles (straight trucks) have greater natural yaw stability. Factors that influence yaw stability are: wheelbase, suspension, steering geometry, weight distribution front to rear, and vehicle tracking.

Stability Systems

During operation, the ECU of the Bendix Advanced ABS system constantly compares performance models to the vehicle's actual movement, using the wheel speed sensors of the ABS system, as well as lateral, yaw, and steering angle sensors. If the vehicle shows a tendency

to leave an appropriate travel path, or if critical threshold values are approached, the system will intervene to assist the driver.

The Bendix ESP system

The ESP® functionality of the Bendix Advanced ABS system responds to a wide range of low- to high-friction surface scenarios including rollover, jackknife and loss of control. It is the recommended system for all power vehicles and especially critical for tractors pulling trailers. In the case of vehicle slide (over-steer or under-steer situations), the system will remove the throttle and then brake one or more of the "four corners of vehicle" (in addition to potentially braking the trailer), thus applying a counter-force to better align the vehicle with an appropriate path of travel. For example, in an over-steer situation, the system applies the "outside" front brake; while in an under-steer condition, the "inside" rear brake is applied.

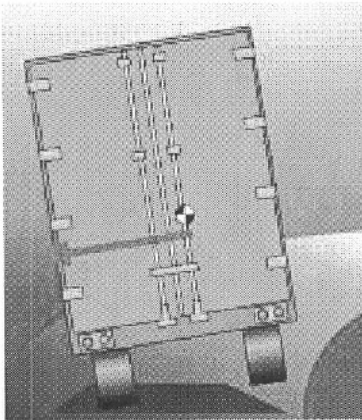

Driving Scenario:

Driving speed exceeds the threshold, creating a situation where the vehicle is prone to rollover on higher-friction surfaces.

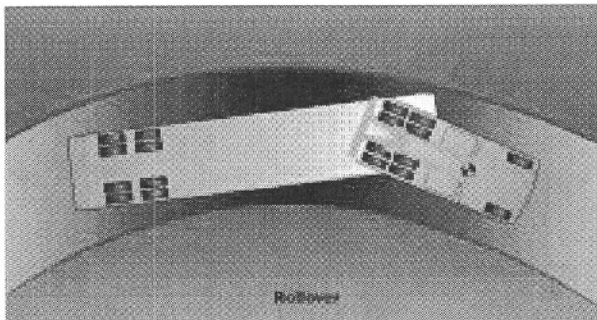

Action by Bendix Stability Solutions:

System applies all brakes to reduce speed, thereby reducing the tendency to roll over.

The Bendix RSP (Roll Stability Program)

Bendix Advanced ABS RSP, an element of the overall ESP system, addresses only rollover conditions and is an alternative for longer wheelbase, higher center of gravity straight trucks. Because of their longer wheelbase these vehicles are less likely to yaw than shorter wheelbase trucks or tractors. In the case of a potential roll event, the system will remove the throttle and quickly apply brake pressure at all wheel ends to slow the vehicle combination below the threshold.

With the addition of a steering angle sensor, the performance of the ESP system in a rollover scenario can be enhanced due to the potential for earlier system intervention. Correspondingly, a roll stability system without a steering angle sensor would intervene later, potentially resulting in a reduced stability margin.

Steering Angle Sensors

The sensor enables the Bendix Advanced stability system to capture the driver's steering input and

intervene if a yaw correction is indicated. The sensor also provides the earliest indication of an increase in lateral acceleration leading to a potential roll event, resulting in much higher stability margin when a vehicle is equipped with a steering angle sensor.

Brake Demand Sensors

Bendix Advanced stability system was designed to supplement the drivers actions. By directly measuring driver brake demand, the system can accurately transition between driver-intended and system-intended braking pressure seamlessly. For example, if in a certain maneuver, the system calculates that 40 psi is needed and the driver is only applying 20 psi, the system compensates automatically to deliver the needed 40 psi. If, however, during the same maneuver the driver steps on the brake pedal quickly to apply a higher (above 40 psi) braking level the driver's braking input overrides the temporary change made by the system.

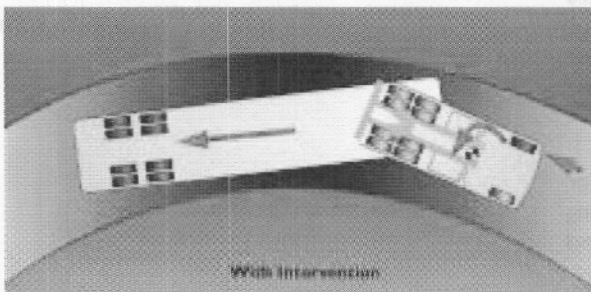
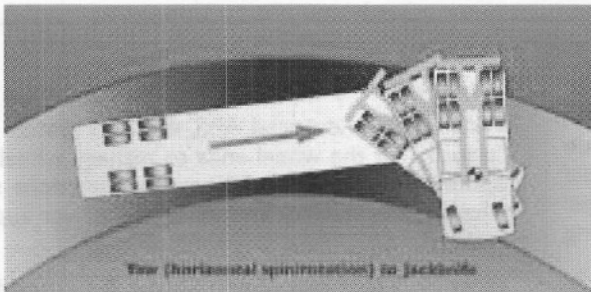

Driving Scenario:

Driving speed exceeds the threshold, and the resulting lateral force causes the vehicle to slide or jackknife on lower-friction surfaces.

Action by Bendix Stability Solutions:

System applies the appropriate brakes to reduce speed and properly align the vehicle, thereby reducing the tendency to slide or jackknife.

Stability System Effectiveness
Sense Situation Quickly and Completely

Bendix RSP Bendix ESP®

		Bendix RSP	Bendix ESP®
Speed	Vehicle velocity	✓	✓
Lateral Acceleration	Measure tendency to roll	✓	✓
Steering	First indication, capture driver intent	✓	✓
Brake Demand	Accurately supplement driver	✓	✓
Yaw Rate	Vehicle spin, correlate to steering		✓

Reaction Time and Robustness

Multi-Level Sensing	Leading indicators aid reaction Cross checking - false interventions	✓	✓
Tuning	Match to vehicle configuration and handling	✓	✓

Braking Control

All Axle	Maximize potential to recover	✓	✓
Individual Wheel	Correct vehicle orientation		✓

Next, during high-speed maneuvers in potential rollover situations, the tandem tires of the tractor and trailer can lift off the ground. If that occurs, the steer axle brakes contribute a much larger percentage of available braking capacity because the wheels that are no longer in contact with the road surface cannot provide braking force.

Third, the ability to apply steer axle brakes individually is a fundamental requirement for yaw (spin) control. By applying brakes at any one or all of a vehicle's "Four Corners," the stability system may be able to correct the vehicle's orientation, mitigating the potential for a jackknife, spin out or slide.

Finally, with the potential regulatory requirements for larger front brakes in the future, the steer axle's braking contribution to a vehicle's overall braking capacity and potential stability margin is expected to increase.

ABS / stability system interaction

With Bendix Advanced ABS, the ABS system is given "priority" at the wheel ends to manage wheel slip for optimal braking. The ABS system functions similarly whether the stability system or the driver applies the brakes.

How do I find out more about Advanced ABS?

Visit the Electronics area of www.bendix.com, or call 1-800-AIR-BRAKE (1-800-247-2725).

Trailer ABS Components

Typical Trailer ABS components are:

- Bendix Electronic Control Units (ECUs) such as the **MC-30™**, **A-18™**, or **TABS6™ Trailer ABS Controllers**
- Wheel Speed Sensors (see page 35)
- Pressure Modulator Valves (also see page 35)
- ABS Indicator Lamps
- Harnesses

Trailer ABS Operation

Examples of trailer ABS systems are:

- Normal braking (operates as a standard relay valve)
- Dolly-axle control (2S/1M), which uses the wheel behavior monitored by two wheel speed sensors to modulate the braking of one (or two) axles in an ABS event

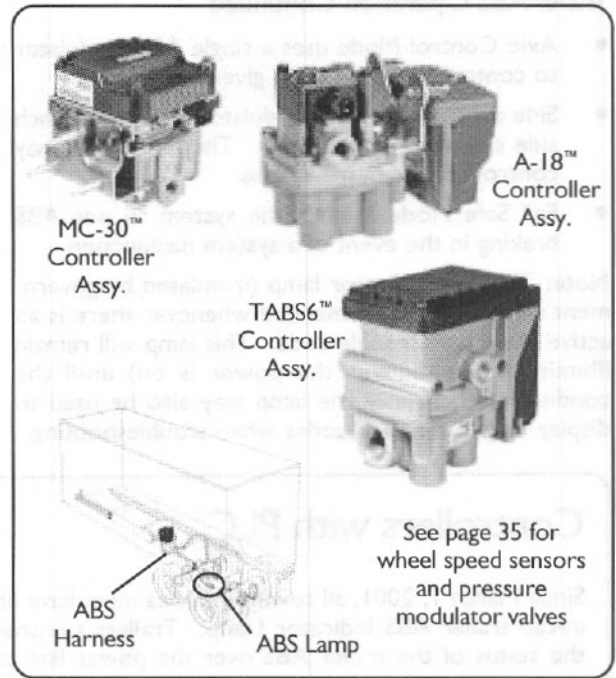

Example of 4S/2M ABS Trailer Schematic

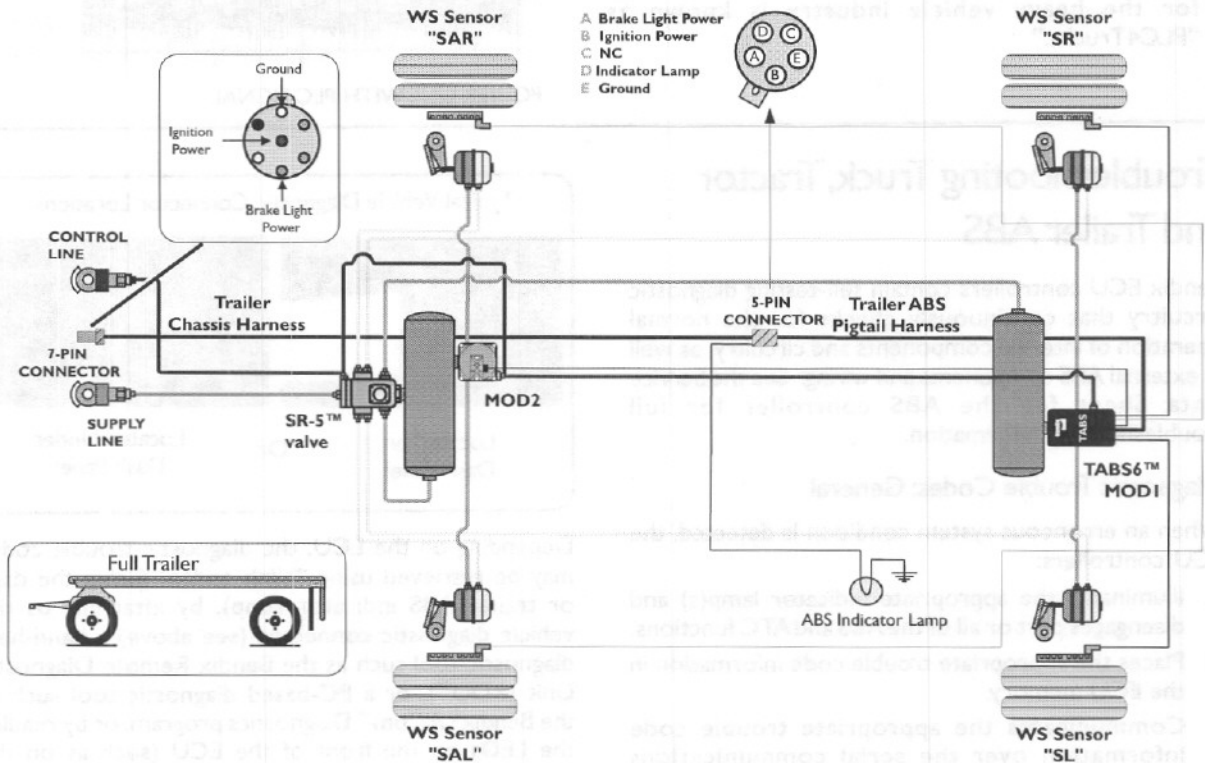

©2004 Bendix Commercial Vehicle Systems LLC • All Rights Reserved

Trailer ABS Operation Continued

- Axle Control Mode uses a single ABS modulator to control both sides of a given axle or axles
- Side control uses ABS modulators to control each side of a vehicle separately. The modulator may control one or more wheels
- Fail Safe Mode reverts the system to non-ABS braking in the event of a system malfunction

Note: The ABS indicator lamp (mandated by government regulations) is illuminated whenever there is an active diagnostic trouble code. This lamp will remain illuminated (whenever the power is on) until the condition is cleared. The lamp may also be used to display diagnostic blink codes when troubleshooting.

Trailer ABS Features

The latest releases of trailer ABS feature:

- Auxiliary Design Language (ADL) which allows customized trailer features to communicate via the ABS ECU with the tractor. Potential examples are: weight, lift axle position, tire temperature and inflation status, slider pin position, refrigeration temperature, load presence, and proximity/reverse alarm.
- Auto-configuration at power-up.
- Customer-defined data storage
- Odometer functionality, including total, trip and service interval tracking

Controllers with PLC

Since March 1, 2001, all towing vehicles must have an in-cab trailer ABS Indicator Lamp. Trailers transmit the status of the trailer ABS over the power line to the tractor using a Power Line Carrier (PLC) signal (see right panel). Typically the signal is broadcast by the trailer ABS ECU. The application of PLC technology for the heavy vehicle industry is known as "PLC4Trucks."

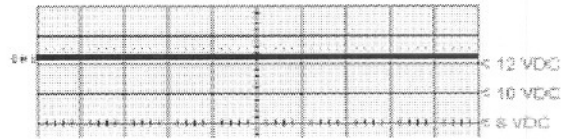

POWER LINE WITHOUT PLC SIGNAL

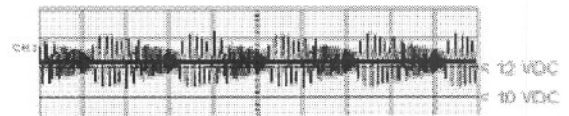

POWER LINE WITH PLC SIGNAL

Troubleshooting Truck, Tractor and Trailer ABS

Bendix ECU controllers contain self-testing diagnostic circuitry that continuously checks for the normal operation of internal components and circuitry, as well as external ABS components and wiring. See the Service Data Sheet for the ABS controller for full troubleshooting information.

Diagnostic Trouble Codes: General

When an erroneous system condition is detected, the ECU controllers:

1. Illuminates the appropriate indicator lamp(s) and disengages part or all of the ABS and ATC functions.
2. Places the appropriate trouble code information in the ECU memory.
3. Communicates the appropriate trouble code information over the serial communications diagnostic link as required.

Typical Vehicle Diagnostic Connector Locations

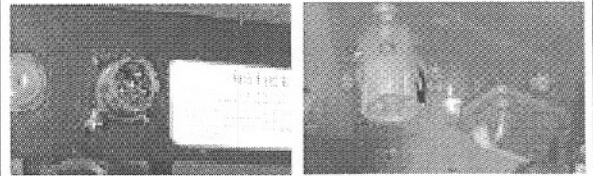

Located on Dash Panel

Or

Located Under Dash Panel

Depending on the ECU, the diagnostic trouble codes may be retrieved using "blink codes" (using the dash or trailer ABS indicator lamp), by attaching to the vehicle diagnostic connector (see above) a hand-held diagnostic tool such as the Bendix Remote Diagnostic Unit (RDU™), or a PC-based diagnostic tool such as the Bendix® ACom™ Diagnostics program, or by reading the LEDs on the front of the ECU (such as on the EC-30™ controller).

Troubleshooting ABS continued.

Bendix® RDU™ (Remote Diagnostic Unit) for Trucks and Tractors*

The Bendix® RDU™ tool provides the technician with a visual indication of ABS component **Diagnostic Trouble Code (DTC)** information. The RDU™ tool is specifically designed for use with Bendix ABS systems and allows the technician to:

- Troubleshoot ABS system component problems using Diagnostic Trouble Code reporting via LEDs.
- Reset Diagnostic Trouble Codes on Bendix ABS ECUs by holding a magnet over the reset in center of RDU™ tool for less than 6 seconds.
- Enter the Self-Configuration Mode used by Bendix ABS ECUs by holding a magnet over the reset area for greater than 6 seconds but less than 30 seconds.

*A trailer version of the RDU™ tool is being developed - check you local Bendix parts outlet for availability.



Nexiq Bendix Application Card

Nexiq provides a Bendix application card for use with the ProLink tool. It can also be used to diagnose most Bendix ABS Controllers. For more information on the Bendix application card visit www.bendix.com, Nexiq at www.nexiq.com, or your local authorized Bendix parts outlet.

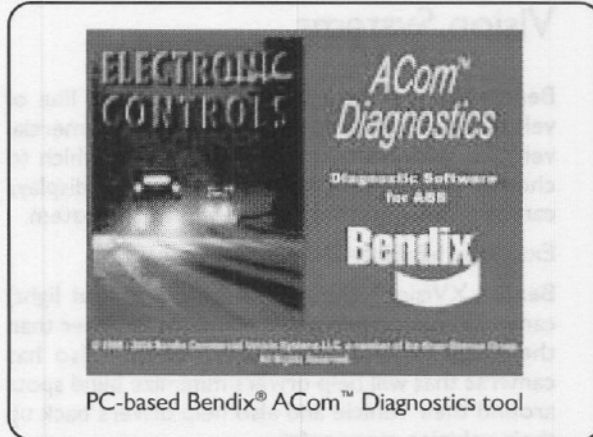

PC-based Bendix® ACom™ Diagnostics tool

Bendix® ACom™ Diagnostics 3.0 Software

Bendix® ACom™ Diagnostics tool is a PC-based software program and is designed to meet RP-1210 industry standards. This software provides the technician with access to all the available ECU diagnostic information and configuration capability, including: ECU information, diagnostic trouble codes and repair information, configuration (ABS, ATC, and more), wheel speed information, etc.

For more information on ACom™ Diagnostics software or RP-1210 compliant tools, go to www.bendix.com or visit your local authorized Bendix parts outlet.

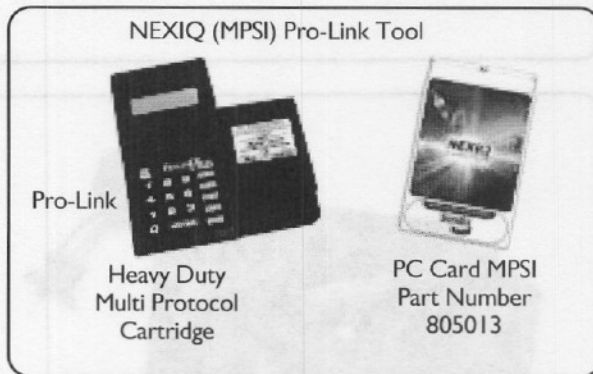

NEXIQ (MPSI) Pro-Link Tool

Pro-Link

Heavy Duty Multi Protocol Cartridge

PC Card MPSI Part Number 805013

Section 7: Miscellaneous Commercial Vehicle Components and Modules from Bendix

Bendix today supplies more than brakes and braking systems, it also provides many other products and systems used on commercial vehicles.

Vision Systems

Bendix has the industry's most complete line of vehicle-mounted vision solutions for commercial vehicles, with many configurations from which to choose. Any selection of the cameras and displays can be combined to create an individual system.

Extended Visibility Day and Night

Bendix XVision® thermal imaging (infrared light) cameras help drivers see 3 to 5 times further than the range of their headlights. Bendix also has cameras that will help drivers minimize blind spots around their vehicle and also help drivers back up their vehicles more safely.

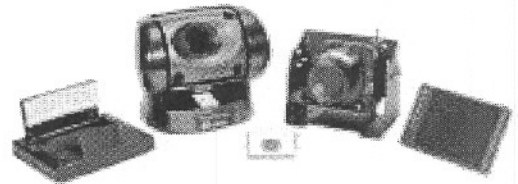

Vision Systems
Family of Products

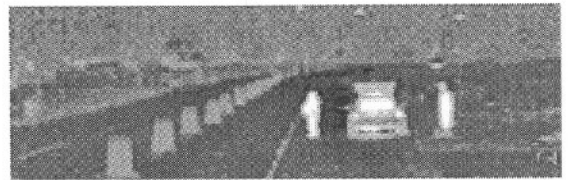

Night Vision Display

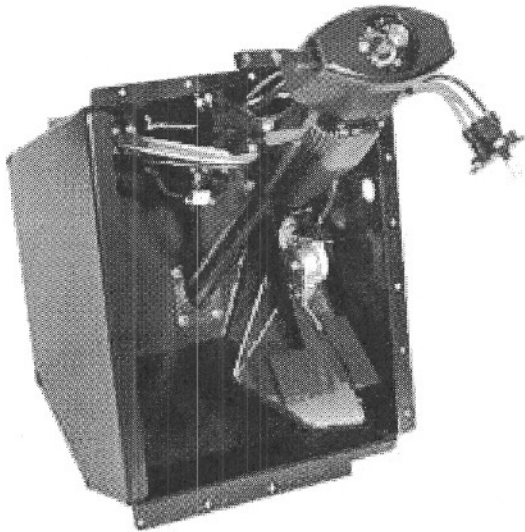

Bendix Modules

Beyond component and systems engineering, Bendix develops and manages integrated vehicle solutions by partnering with vehicle manufacturers. These joint development projects use program management and engineering expertise at Bendix to help our customers develop new vehicle designs and shorten the time taken to bring these vehicles to the marketplace.

For more information, contact Bendix at:
info@bendix.com

Pre-Trip Safety Inspections

The Bendix® BVA-85™ brake valve actuator enables pre-trip brake inspections safely and easily with only one person. It uses air from the trailer supply of the Bendix® MV-3™ valve to keep the foot pedal applied at an accurate 85 psi service brake application.



BVA-85™ Brake Valve Actuator

This valve is also used as a work brake for unique systems, e.g. to apply the service brakes for door interlock systems for transit and school bus applications, refuse interlock systems, and other severe service vehicle interlock systems including paving and construction.

Fan Clutches

Fan clutches are air-operated, normally engaged, on-off clutches that control the engine cooling fan. The fan clutch senses the engine coolant temperature and maintains engine temperature by engaging or disengaging the cooling fan. Using a fan clutch helps conserve fuel and engine efficiency, and it leads to faster warm-ups and a quieter vehicle. Bendix recommends snap-action electronic fan clutch controls for both performance and reliability.

The FD-L™ and FD-3™ fan clutches are designed to be fail safe. Both models feature spring engagement and air disengagement.

Most later model vehicle/engine combinations are available in kit form and contain all the necessary parts for installation. Control kits are also available, including those for shutter-equipped and air-conditioned vehicles.

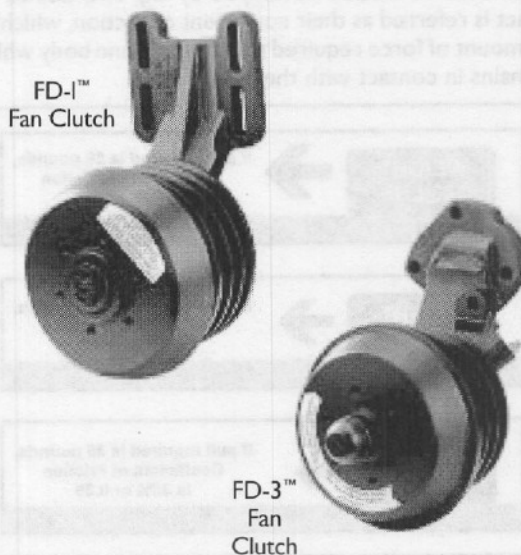

FD-1™ Fan Clutch

FD-3™ Fan Clutch

Caution: Fan bolts must not enter the fan plate more than 1/2" or less than 3/8".

Electronic Throttles

The ET-S™ and ET-S2™ electronic throttles are installed on vehicles with electronically controlled, fuel management systems on newer diesel engines. The electronic throttle replaces the mechanical accelerator pedal and linkage found on conventional diesel engine, fuel management systems. It provides graduated throttle control by communicating with the Electronic Control Module (ECM) controlling the engine.



ET-S2™ Electronic Throttle

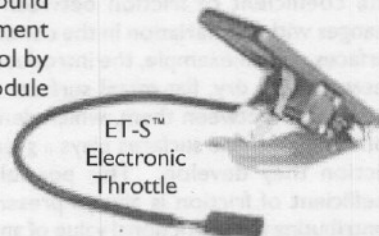

ET-S™ Electronic Throttle

Section 8: The Fundamentals of Air Braking

Friction

Air brakes are mechanical devices that use friction to slow or stop vehicles. An understanding of the laws of friction will be a useful introduction to the concepts behind brake design and maintenance.

Coefficient of Friction

Friction is the resistance to relative motion between any two bodies in contact, and it varies not only with different materials, but also with the condition of the materials. The amount of friction developed by any two bodies in contact is referred to as their coefficient of friction, which is the amount of force required to move the one body while it remains in contact with the other.

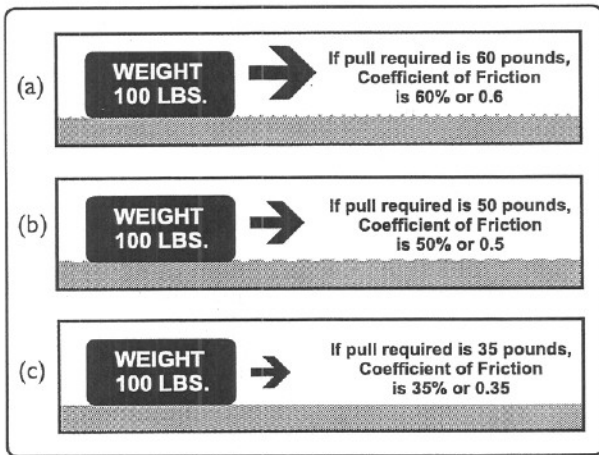

FIGURE 1 - Coefficient of Friction

The coefficient of friction is expressed by the relation of the amount of force divided by the weight of the moving body. Let's look at three examples:

In Figure 1, example (a), if the moving body weighs 100 pounds, and a force of 60 pounds is required to keep it moving while it remains in contact with another body, then the coefficient of friction between the two bodies is 60% or 0.6. For (b), if 50 pounds force is necessary to keep it moving, the coefficient of friction is 50% or 0.5. For (c), if only 35 pounds force is required, the coefficient of friction is 35% or 0.35.

The coefficient of friction between any two surfaces changes with any variation in the condition of one or both surfaces. As an example, the introduction of oil or grease between two dry, flat metal surfaces will greatly reduce the friction between them, which demonstrates that the condition of these surfaces plays a great part in the actual friction they develop. This possible variation in the coefficient of friction is always present when any factor contributing to the frictional value of any material is subject to change either permanently or temporarily.

Heat is always present where friction is being developed. For example, when a bearing is not properly lubricated, the lack of lubrication causes a rise in the coefficient of friction with a resultant rise in the heat produced. The heat may reach a point where the bearing fails.

Energy of Motion Becomes Heat Energy

Since friction is the resistance to relative motion between two bodies in contact and since friction results in heat, a more complete definition of a brake would be that it is a mechanical device for retarding the motion of a vehicle by means of friction, thereby changing the energy of motion into heat energy.

Stated another way, when the speed of a vehicle is reduced by applying the brakes, the energy of motion is actually changed into heat energy, and the brakes must dissipate or absorb the heat developed.

Braking Force

It is difficult to appreciate the tremendous forces involved in stopping a modern commercial vehicle, particularly from the higher speeds.

A simple method of explaining this is to make a comparison between the horsepower required to accelerate a vehicle and the horsepower required to stop it. A truck with an engine capable of developing 100 horsepower will require about one minute to accelerate to 60 miles per hour. The same vehicle should be capable of easily stopping from 60 miles per hour in not more than six seconds. Ignoring the unknown quantities, such as rolling friction and wind resistance which play a part in all stops, the brakes must develop the same energy in six seconds as the engine develops in 60 seconds; in other words, the brakes do the same amount of work as the engine in one-tenth the time and must develop approximately 1,000 horsepower during the stop.

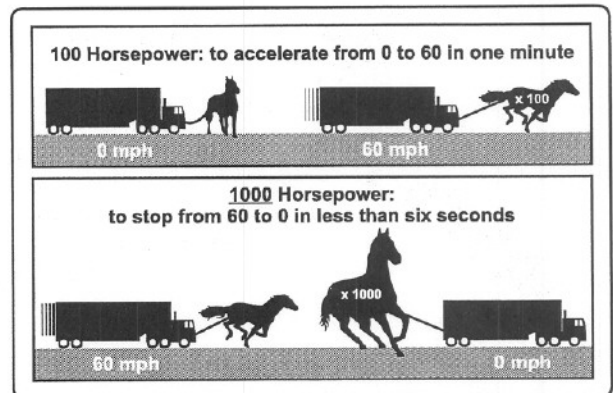
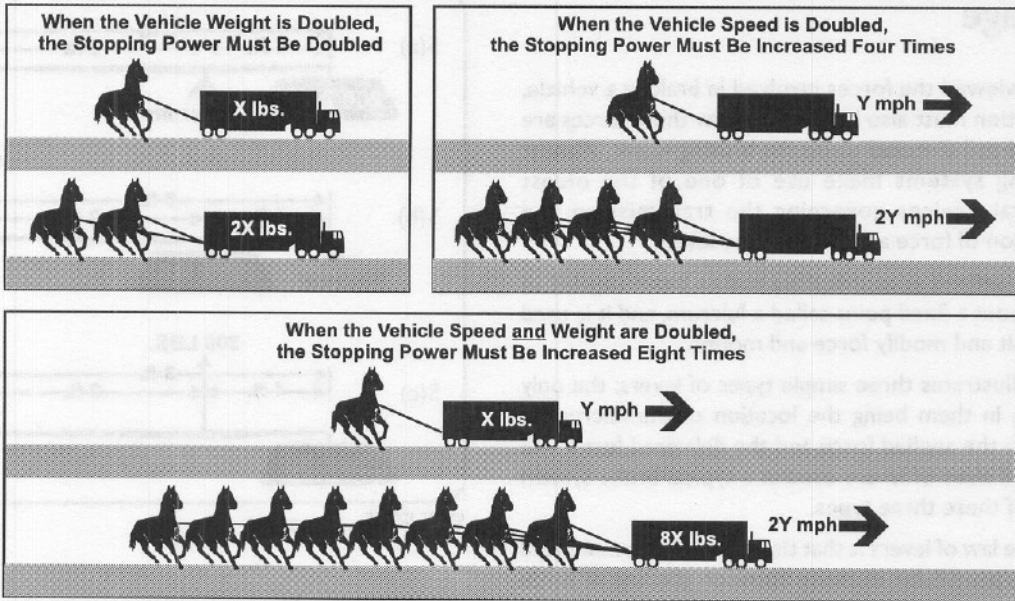

FIGURE 2 - Forces Involved in Braking



(Note: For illustration the Figure above shows horses; however in this case we are illustrating the effect of forces, not horsepower amounts, as in Figure 2.)

FIGURE 3 Effect of Weight and Speed on Braking Force Required

Effect of Weight and Speed

Other factors to be considered are the effects on braking when the weight and speed of a vehicle are increased. If the weight of the vehicle is doubled, the energy of motion to be changed into heat energy is also doubled. If the brake cannot properly dissipate and absorb the increased heat caused by the vehicle weight (in excess of the vehicle design spec's), poor braking performance will result. Brake systems are designed to properly control a vehicle loaded up to its gross vehicle weight (GVW). Never exceed the GVW for a vehicle.

The effect of higher speeds on braking is much more significant. Comparing stops from a speed of 20 miles per hour with stops from a speed of 40 miles per hour, engineering calculations show there is actually four times as much energy of motion to be changed to heat energy during a stop from 40 miles per hour as there is during a stop from 20 miles per hour. Thus, if the speed is doubled, four times as much stopping power must be developed, and the brakes must absorb or dissipate four times as much heat. If the speed is three times higher, the stopping power needed is nine times higher.

It naturally follows that **if both the weight and speed of a vehicle are doubled, the stopping power must be increased eight times** and the brakes must absorb or dissipate eight times as much heat.

Another way of illustrating the effect of speed on stopping ability is to compare the stopping distance if the speed is increased without increasing the weight.

In Figure 4, the vehicle shown stops from 20 miles per hour in 30 feet. At 40 miles per hour it would typically require 120 feet to stop, and 60 miles per hour it would typically need 270 feet to stop.

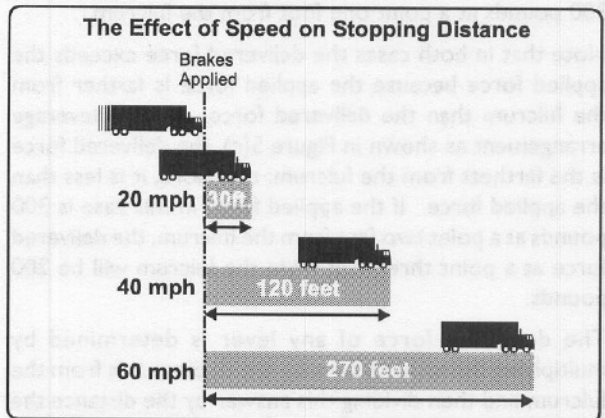

FIGURE 4 - Effect of Speed on Stopping Distances

Introducing both weight and speed into the comparison again, a 10,000 pound vehicle traveling 60 miles per hour has 18 times as much energy of motion as a 5,000 pound vehicle traveling at 20 miles per hour. If the same stopping power is used, a 5,000 pound vehicle which stops from 20 miles per hour in 30 feet, when loaded to 10,000 pounds and is traveling at 60 miles per hour will require 18 times (540 feet), or more, to stop. Note: Many other factors, including the road surface, brake friction material and tire condition, etc. would also affect the stopping distance.

Leverage

Having reviewed the forces involved in braking a vehicle, consideration must also be given to how these forces are developed and directed to do the braking work. Almost all braking systems make use of one of the oldest mechanical devices governing the transmission and modification of force and motion, the lever.

A lever is defined as an inflexible rod or beam capable of motion about a fixed point called a fulcrum, and it is used to transmit and modify force and motion.

Figure 5 illustrates three simple types of levers; the only difference in them being the location of the fulcrum in relation to the applied force and the delivered force. All shapes and sizes of levers used in a typical brake system are one of these three types.

The simple law of levers is that the applied force multiplied by the perpendicular distance between the line of force and the fulcrum always equals the delivered force multiplied by the perpendicular distance between the fulcrum and the line of force. Thus, with a leverage arrangement as shown in view 5(a), an applied force of 100 pounds two feet from the fulcrum will give a delivered force of 200 pounds at a point one foot from the fulcrum. With a leverage arrangement as shown in Figure 5(b), an applied force of 100 pounds three feet from the fulcrum will lift 300 pounds at a point one foot from the fulcrum.

Note that in both cases the delivered force exceeds the applied force because the applied force is farther from the fulcrum than the delivered force. With a leverage arrangement as shown in Figure 5(c), the delivered force is the farthest from the fulcrum; therefore, it is less than the applied force. If the applied force in this case is 300 pounds at a point two feet from the fulcrum, the delivered force at a point three feet from the fulcrum will be 200 pounds.

The delivered force of any lever is determined by multiplying the applied force by the distance it is from the fulcrum and then dividing this answer by the distance the delivered force is from the fulcrum.

In determining the distance at which any force is acting on a lever, the true length of the lever arm is the perpendicular distance from the force to the fulcrum, regardless of the shape of the lever. The lever arm is always measured at right angles to the direction of the force.

The product of the force acting on a lever, multiplied by the distance the force is from the fulcrum, is called the turning moment, and when this relates to a shaft, it is

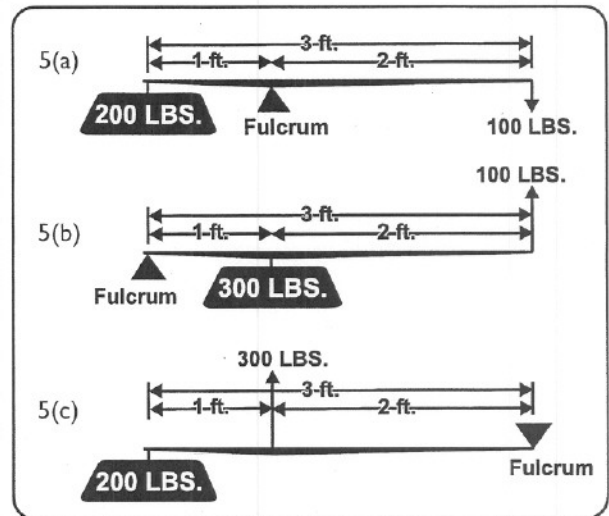

FIGURE 5 - Leverage

called torque. The turning moment or torque is usually expressed in inch-pounds, foot-pounds, foot-tons, etc., depending upon whether the force is measured in pounds or tons and whether the distance is measured in inches or feet. As an example – a force of 100 pounds acting on a lever arm five inches long would result in a turning moment or torque of 500 inch pounds.

The most easily recognized lever in an air brake system is the slack adjuster. The length of the lever arm of a slack adjuster is always the perpendicular distance between the center line of the brake camshaft opening and the center line of the clevis pin.

Another form of lever – not always recognized – is the brake cam. All brake cams are levers and are used to transmit and modify the torque and turning motion of the brake camshaft in such a way that the brake shoes are spread and forced against the brake drum, not only in the proper direction but also with the proper force. Spreading the shoes in the proper direction, of course, depends on the proper location of the cam in respect to the location of the brake shoes. The transmission of the proper force is partially determined by the effective lever length of the cam. If the effective lever length of the cam is too long or too short, the brake shoe force will be correspondingly too little or too much.

It is also important that the effective lever length of the cam remains constant as the lining wears and the shoes have to be spread further; otherwise, the brake performance would vary as the lining wears.

Another form of lever found in drum-brake forms of braking systems is the brake shoe. This is one of the simpler forms because it is easily recognized as a beam, fulcrumed at one end on the hinge pin, which forces the brake lining against the drum when the brake cam force is applied to the other end.

Perhaps the least easily recognized lever in a drum brake system is the relation of the brake drum diameter to the tire diameter. In order to understand this fully it must be remembered that although the brakes stop the brake drums and wheels, it is always the tires and road surface that stop the vehicle. This is clearly demonstrated when quick stops are attempted on wet or icy roads. Under these conditions the brake equipment may still be as efficient as ever in stopping the wheels, but its ability to stop the vehicle quickly diminishes because there is not sufficient friction between the tire and road to develop the necessary retarding force.

Returning to the principles of leverage involved in the relation of the tire and brake drum size, the retarding force developed by the brake shoes acting against the drum is working on an effective lever length of the brake drum radius. Counteracting this is the retarding force developed between the tire and the road, working on an effective lever length of the rolling radius of the tire. Since it is not practical to have brake drums as large as the tires, the principles of leverage require development of a greater retarding force between the brake shoes and the drums than between the tire and the road. Also, since a rubber tire on a smooth, dry road surface has a higher coefficient of friction than brake lining against a brake drum, it is necessary to develop additional retarding force between the brake shoes and brake drum in order to overcome the difference in friction.

Deceleration

In discussing brakes, the term deceleration is often used. This term expresses the actual rate at which vehicle speed is reduced and usually denotes the speed being reduced each second, in terms of miles per hour or feet per second.

As an example as shown in Figure 6 - if a vehicle is moving at the rate of 20 miles per hour, and one second later its speed is only 18 miles per hour, the vehicle has reduced its speed by two miles per hour during one second, its deceleration rate is two miles per hour per second.

In the same way, if a vehicle is moving at a rate of 30 feet per second, and one second later its speed is only 20 feet

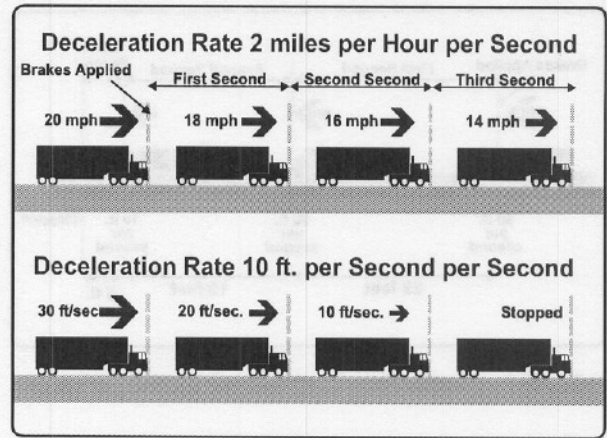

FIGURE 6 - Deceleration

per second, then it is decelerating at the rate of ten feet per second per second.

Therefore, the change in the rate of speed of a vehicle during a slowdown or stop is expressed by first stating the rate of speed being lost, such as miles per hour or feet per second, and then by stating the time required for this rate of speed to be lost.

Thus, in examining the expression covering a deceleration rate of say, "ten feet per second per second," the first part - "ten feet per second" - is the rate of speed being lost, and the second part - "per second" - is the time in which the loss of ten feet per second takes place.

If a vehicle is moving at a known rate, and is decelerating at a known rate, the stopping time will be the initial speed divided by the deceleration rate, provided both the rate of speed and the deceleration rate are expressed on the same basis. As an example - if a vehicle is moving at the rate of 30 feet per second and is decelerating at the rate of ten feet per second, the stopping time will be the initial speed of 30 feet per second divided by the deceleration rate of ten feet per second per second, or a stopping time of three seconds.

This perhaps can be more easily understood if explained in the following manner; if a vehicle is moving at the rate of 30 feet per second and begins to decelerate at the rate of ten feet per second per second, at the end of the first second it will be traveling 20 feet per second; at the end of the second second, it will be traveling ten feet per second, and at the end of the third second, it will be stopped. Thus, by losing speed at the rate of ten feet per second per second, it would lose its initial speed of 30 feet per second in three seconds.

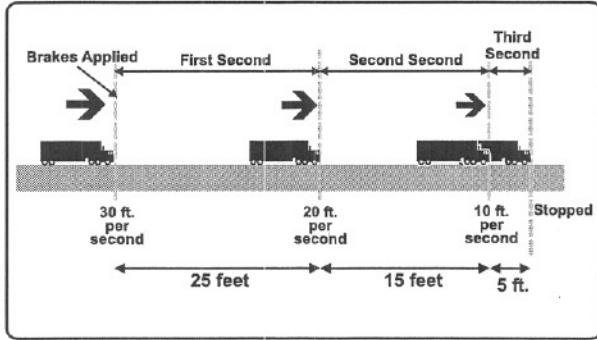

FIGURE 7 - Deceleration at 10 feet per second per second

Similarly, if the initial speed is 20 miles per hour and the deceleration rate is two miles per hour per second, the stopping time will be ten seconds.

One important thing to remember in respect to stopping vehicles is the fact that while the deceleration rate may be constant for each second during the stop, the distance the vehicle travels each second during the stop varies greatly as the speed decreases.

This is illustrated in Figure 7 which also shows a vehicle decelerating at the rate of ten feet per second per second from an initial speed of 30 feet per second, but the positions of the vehicles are shown in relation to the distance traveled each second during the stop. This shows that although the rate of deceleration remains constant throughout the stop, the vehicle actually travels 25 feet during the first second after the brakes were applied, 15 feet during the second second, and only five feet during the third second.

The distance being traveled each second during the stop is always greater at the beginning of the stop. To keep stopping distance as short as possible, it is important that the brakes become fully effective when the pedal is depressed by the driver.

Any time lost between the instant the brake pedal is depressed and the instant actual deceleration begins is important because the vehicle continues to travel at close to its initial speed. In this case, the loss of only one second between the instant the driver depresses the brake pedal and the point where the brakes are really applied will result in lengthening the actual stopping distance by 30 feet. Thus, if four seconds instead of three elapse between the instant the driver depresses the brake pedal and the instant the vehicle stops, the actual stopping distance will be increased from 45 feet to 75 feet. In other words, by reducing the stopping time under these conditions by only one second

or 25%, the actual stopping distance is reduced by 30 feet or 40%.

It is this part of brake fundamentals which is not often considered in evaluating brake performance, particularly when different forms of brakes are involved. A common method of testing brakes is by the use of a decelerometer—a device that determines the maximum rate of deceleration developed during a stop and which shows a calculated stopping distance from a speed of 20 miles per hour based on the maximum rate of deceleration developed during a stop. Such instruments do not, however, make allowances for lost time before the braking system develops full power and therefore are not suitable for analyzing time lag factors in brake performance.

The true performance of any type of brake system in terms of stopping time or stopping distance can only be determined by actually measuring the time and distance the vehicle travels from the instant the driver depresses the brake pedal to the point where the vehicle actually stops. Such tests can, of course, be made comparative only by using instruments to determine accurately the speed of the vehicle at the instant the brake pedal is depressed.

In so far as brakes are concerned, a driver is mainly interested in the amount of time and the distance required to bring the vehicle safely to a stop under emergency conditions as measured from the instant he or she depresses the brake pedal. Any lag in the time between the instant the brake pedal is depressed, and the instant the brakes apply, affects stopping distance.

The Fundamentals of Compressed Air

Compressed air is air which has been forced into a smaller space than that which it would ordinarily occupy in its free or atmospheric state.

Free air which we breathe — or atmosphere — is normally always under pressure because of the weight of the air above it. This pressure amounts to 14.7 pounds per square inch at sea level, and it decreases as the altitude increases.

The normal atmospheric pressure of 14.7 pounds per square inch is usually ignored and the atmosphere is considered as being free air under no pressure. Thus, the pressure of compressed air is commonly indicated by stating the amount the pressure, in pounds per square inch, is above the atmosphere. This is the reason air pressure gauges register zero when connected only to atmosphere.

FREE SPRING – FREE AIR

The energy of compressed air is best compared to the energy of a coiled spring. Figure 8 shows a coiled spring in its free position and air in its free or atmospheric state.

COMPRESSED SPRING – COMPRESSED AIR

When the spring is compressed, as shown in Figure 9, energy is stored in it. Similarly when free air is compressed, energy is stored in the air. This energy can be used to do work, and due to the flexibility of air such energy can be stored in a relatively small space.

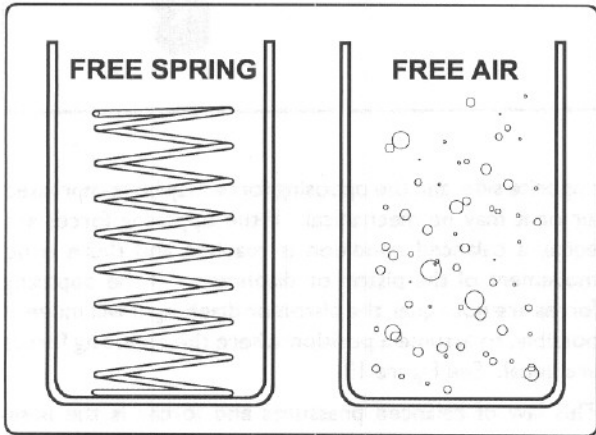

FIGURE 8 - Free Spring / Free Air

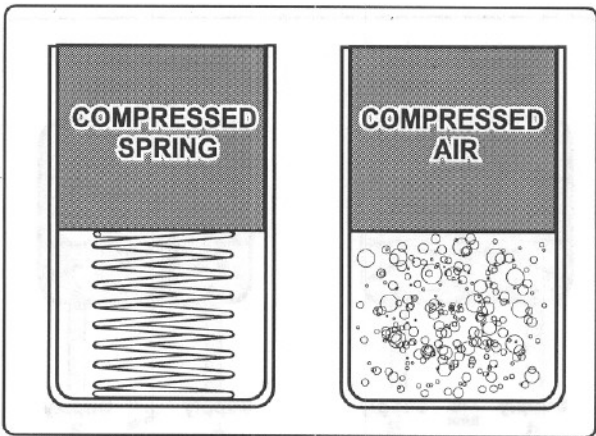

FIGURE 9 - Compressed Spring / Compressed Air

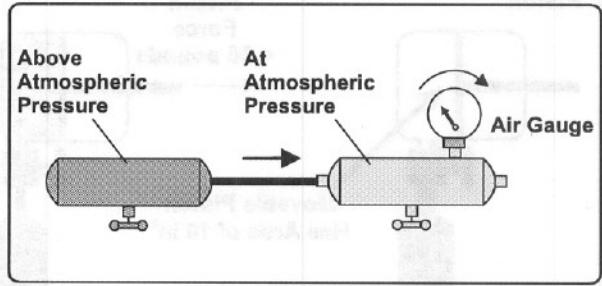

FIGURE 10 - Free Spring / Free Air

See Figure 10. If two reservoirs are connected and one contains air above atmospheric pressure and the other contains air at only atmospheric pressure, air will flow from the reservoir with the higher pressure until the pressures in both reservoirs equalize or until the flow is interrupted by some outside force, such as the closing of a valve in the connecting line. This is similar to the action of liquids, except that pressure is the controlling medium, whereas, the force of gravity would ordinarily be the controlling medium in the case of liquids.

We saw earlier that normal atmospheric air is really at a pressure of 14.7 pounds per square inch. In Figure 11, the reservoir on the right has a volume of six cubic feet. When another six cubic feet of air is added into it, the gauge pressure of the air in the reservoir, which originally read zero, will rise to 14.7 pounds. It follows that each time a quantity of free air equal to the volume of the reservoir is forced into it, the gauge pressure will rise another 14.7 pounds per square inch.

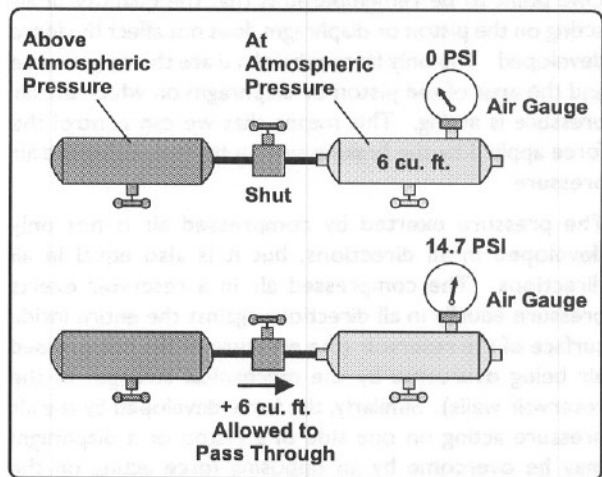

FIGURE 11 - Free Spring / Free Air

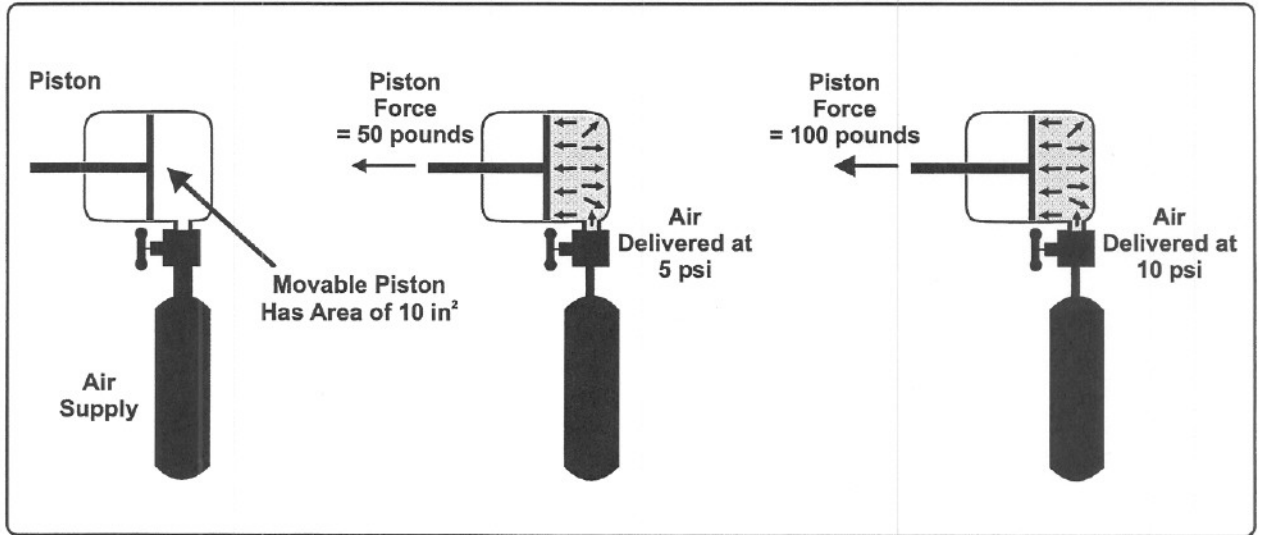

FIGURE 12 - Fundamentals of Compressed Air

In Figure 12, we see a piston with an air-tight chamber behind it. When compressed air enters the chamber it will cause the piston to move until it encounters a resistance equal to the force developed by the compressed air. Because the air pressure is based on pounds per square inch, it follows that the compressed air will develop a force in pounds on the movable object equal to the product of the air pressure multiplied by the effective area of the movable object. If a piston or a flexible diaphragm in a brake chamber has an area of ten square inches and air at five pounds per square inch pressure is acting on the piston or diaphragm, the developed force will be 50 pounds. Similarly, if air at a pressure of ten pounds per square inch is acting upon it, a force of 100 pounds will be developed.

One point to be remembered is that the quantity of air acting on the piston or diaphragm does not affect the force developed. The only factors involved are the air pressure and the area of the piston or diaphragm on which the air pressure is acting. This means that we can control the force applied by the braking system by controlling the air pressure.

The pressure exerted by compressed air is not only developed in all directions, but it is also equal in all directions. The compressed air in a reservoir exerts pressure equally in all directions against the entire inside surface of the reservoir (the pressure of the compressed air being overcome by the mechanical strength of the reservoir walls). Similarly, the force developed by the air pressure acting on one side of a piston or a diaphragm may be overcome by an opposing force acting on the

opposite side, and the opposing force may be compressed air or it may be mechanical. If the opposing forces are equal, a balanced condition is reached and there is no movement of the piston or diaphragm. If the opposing forces are not equal, the piston or diaphragm will move, if possible, to assume a position where the opposing forces are equal. See Figure 13.

This law of balanced pressures and forces is the basic principle governing the design and operation of the control and actuating devices in an air brake system.

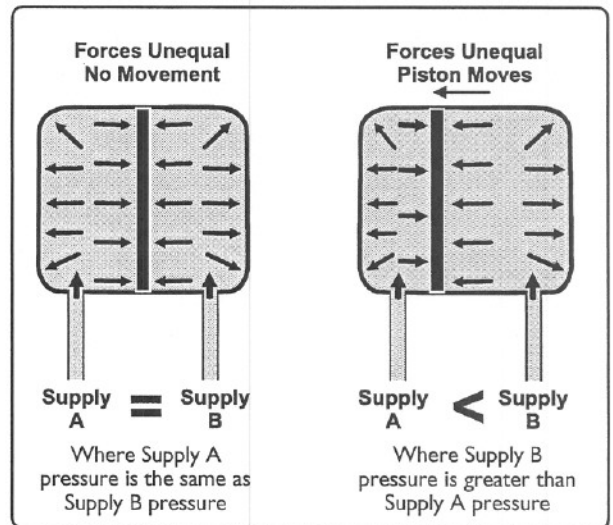

FIGURE 13 - Fundamentals of Compressed Air

The Fundamentals of Compressed Air Brakes

Compressor, Reservoir and Brake Valve

In an air brake system, the compressor supplies the compressed air for brake operation by taking free air and compressing it to 100-120 P.S.I. (Maximum pressure in an air brake system is generally 150 P.S.I.)

The compressed air passes from the compressor into the reservoir and the air brake system where it (and its energy) are stored until needed by the driver for a brake application.

Service Brake System

When the brake valve is operated by the driver, air flows to the chambers where its energy is transformed into the mechanical force and motion necessary to apply the brakes.

Braking Forces - Effect of Air Pressure

This control of the braking force by controlling the air pressure in the chambers is illustrated in Figure 14. It shows the resulting forces in pounds of various air pressures with a chamber having an effective diaphragm area of 24 square inches.

The important point is that the air pressure in a brake chamber can be controlled so the brake chamber will develop the required force.

Braking Forces - Effect of Brake Chamber Size

Different sizes of vehicles and different axles of the same vehicle may require different braking forces, depending on the weight of the vehicle or the weight distribution

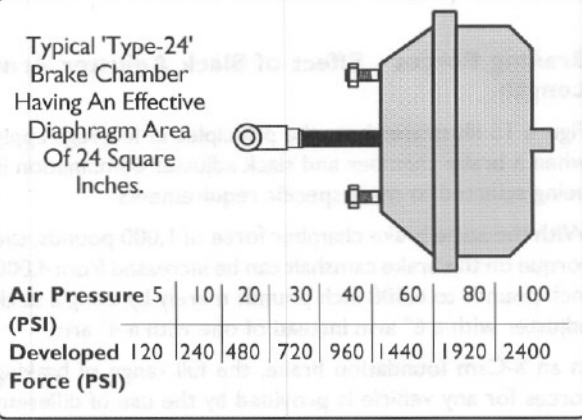

FIGURE 14 - Braking Forces-Effect of Air Pressure

between axles of the same vehicle. These variations in the braking force are design variations because the maximum and minimum force required must be properly provided before good performance can be obtained throughout the entire braking range. [Note: Rotochambers are larger, heavier style of brake chamber typically used on heavier, off-road equipment where their constant output and longer push-rod stroke is useful.]

Figure 15 illustrates the developed force in pounds of each of several different sizes of brake and rotochambers when supplied with air pressure at 60 pounds per square inch. The effective area of the different brake chambers generally varies from six square inches to 36 square inches and their developed force at 60 pounds air pressure generally varies from 360 pounds to 2,160 pounds. This permits the choice of a chamber size suitable for properly operating any size or type of foundation brake.

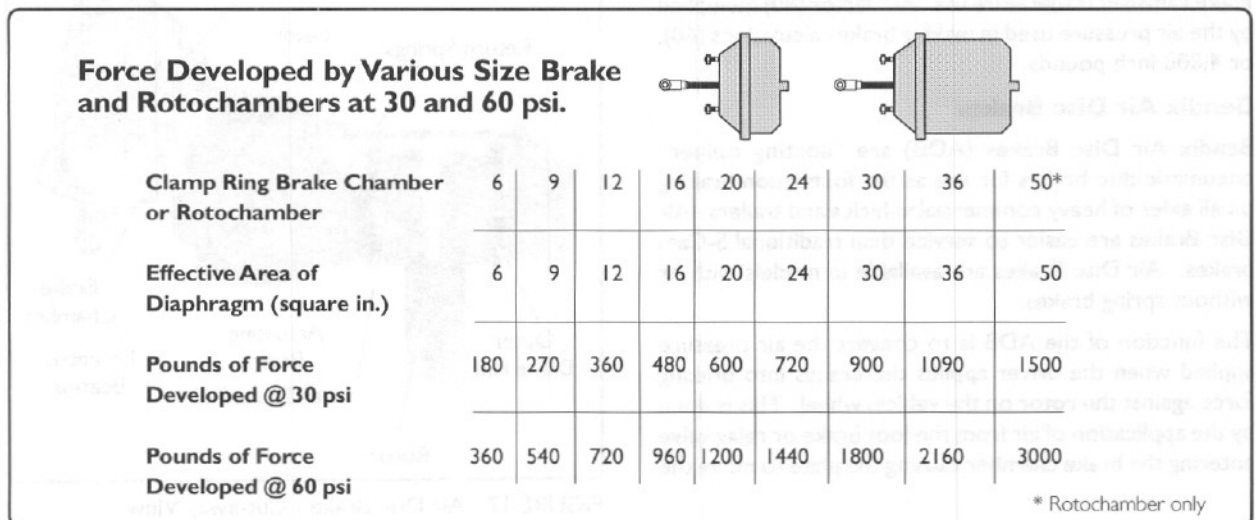

FIGURE 15 - Braking Forces-Effect of Brake Chamber Size

Braking Forces - Effect of Slack Adjuster Arm Length

Figure 16 illustrates how the principles of leverage apply when a brake chamber and slack adjuster combination is being selected to meet specific requirements.

With the same brake chamber force of 1,000 pounds, the torque on the brake camshaft can be increased from 4,000 inch pounds to 6,000 inch pounds merely by using a slack adjuster with a 6" arm instead of one with a 4" arm.

In an S-Cam foundation brake, the full range of braking forces for any vehicle is provided by the use of different sizes of brake chambers and slack adjusters.

A term which is used to express the relation of the brake chamber size and slack adjuster arm length is "AL" factor. The "AL" factor differs from torque or turning moment in that only the variable factors which determine the force are expressed. The reason for this is that an air pressure of 60 pounds is generally used in calculating air braking forces and therefore, is considered constant. The length of the slack adjuster lever arm and the size or effective area of the brake chamber acting on the slack adjuster are the two variables altered to meet braking requirements. The product of the effective area of the brake chamber and the length of the slack adjuster arm is expressed as the "AL" factor, which, when multiplied by the 60 pounds air pressure used in making brake calculations, determines the torque on the brake camshaft. As an example: If a brake chamber having an effective area of 16 square inches is acting on a slack adjuster having an arm length of five inches, the "AL" factor is 80. The actual torque on the brake camshaft is therefore the "AL" factor (80) multiplied by the air pressure used in making brake calculations (60), or 4,800 inch pounds.

Bendix Air Disc Brakes

Bendix Air Disc Brakes (ADB) are "floating caliper" pneumatic disc brakes for use as the foundation braking on all axles of heavy commercial vehicles and trailers. Air Disc Brakes are easier to service than traditional S-Cam brakes. Air Disc Brakes are available in models with or without spring brakes.

The function of the ADB is to convert the air pressure applied when the driver applies the brakes into braking force against the rotor on the vehicle wheel. This is done by the application of air from the foot brake or relay valve entering the brake chamber causing the plate to move the

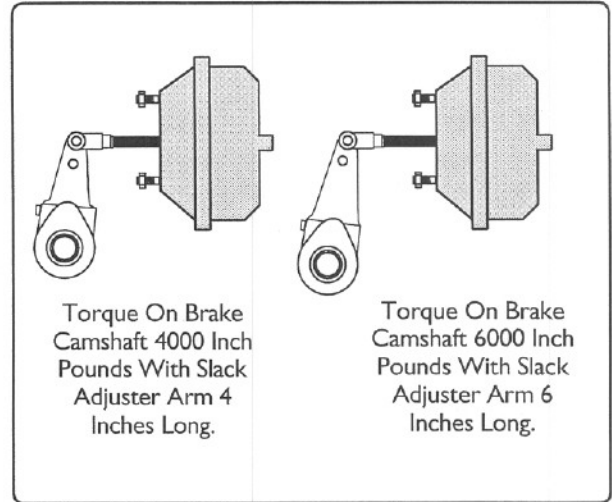

FIGURE 16 - Braking Forces-Effect of Slack Adjuster Arm Length

push rod outwards. The push rod exerts force on the lever (see Figure 17) and this force is transferred and multiplied as it turns around the eccentric bearing. The bearing and the connected actuating beam move outward, overcoming the force of the two return springs. The force is then transferred to the two threaded tubes, tappets and finally to the inner and outer brake pads.

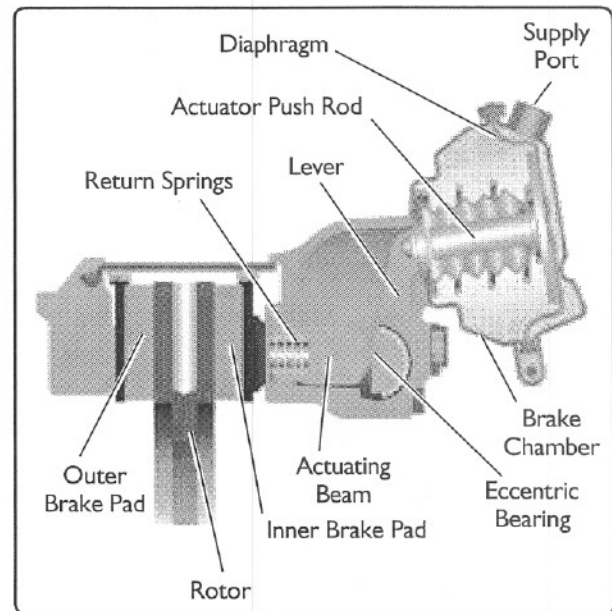

FIGURE 17 - Air Disc Brake - Cut-away View

Air Brake System Balance

The air brake system is one of the most important safety systems on a vehicle. Air brake systems are carefully designed with valves, tubing or hoses, etc., selected to result in balanced vehicle braking performance - one where all the brakes apply as close to simultaneously as possible and with the desired amount of force. Proper vehicle maintenance will result in the original performance being retained and so component replacement and general brake system maintenance are very important. Routine system maintenance operations should be performed with this in mind.

Two major areas that we cover here are:

I. Pneumatic (Air) and II. Mechanical.

I. Pneumatic (Air) Systems

General

An ideal or balanced braking system is one in which the braking pressure reaches each actuator as close to simultaneously as possible and at the same pressure level (and at an appropriate level to achieve torque balance with respect to the axle's loading).

Transmission Time

Vehicle manufacturers must comply with the air system timing requirements of Government regulations (e.g. U.S. FMVSS 121, Canadian CMVSS 121). In establishing this performance, vehicle manufacturers carefully select tubing and hose sizes. Air application and release performance is partially dependent upon the size and volume of chambers, vehicle weights and locations of the valves and chambers, or distance the air must travel. Performance is engineered into the vehicle by the manufacturer; the role of the vehicle owner and/or mechanic is to preserve that pneumatic performance. Here are a few tips to assist in that effort.

Tubing

When replacing tubing or hose, always replace with DOT or SAE approved tubing of the same size. These sizes have been determined by the vehicle manufacturer to obtain desired performance. If copper tubing is used, always make sure to ream and de-burr the tubing after cutting. Check carefully for restrictions such as kinking or bending, and make sure tubing and hoses are properly supported. Use the proper size fittings and make certain they are not restricted. As a rule, do not replace straight fittings with elbows. Note: it takes as much time for air to flow through an elbow fitting as through 6-7 feet of tubing or hose.

Valving

When replacing valves in the air brake system, be sure that the function of the replacement valve is comparable with the valve being replaced. Wherever possible, we recommend genuine Bendix parts be used. Then you can ensure that the new valve is equal in performance to the original. Bendix adheres to an industry recommendation which requires that, for some valves, the valve type and some of its critical characteristics are identified by a metal tag or washer to help select the correct replacement. (For example: relay valve crack pressures.)

Air System Contamination

Air brake systems need clean air to function at their best. Almost all vehicles with air brakes now use an air dryer to remove contaminants from the air before it enters the system.

A properly maintained desiccant-type air dryer will remove almost all the water vapor and oil droplets present in the compressed air arriving from the air compressor.

Typically, air dryer cartridge replacement intervals are:

- Every 3 years/300,000 miles for a low air use vehicle (e.g. line haul, single trailer, with 5 or less axles) or,
- Every year/100,000 miles for a high air use vehicle (e.g. refuse truck, transit bus, bulk unloader, or line haul with 6 or more axles.)

A properly maintained air dryer will substantially reduce the potential for freeze-ups in the system.

If for some reason an air dryer is not in use, daily reservoir draining can help reduce the amount of contamination in the system. While reservoir draining can not eliminate valve contamination, it can reduce the amount.

Trailer Air System Contamination

Contamination by insects, fibrous material, etc. can affect trailer air brake systems. The Cyclone DuraDrain™ trailer water separator installed in the trailer control and/or supply lines near the gladhands where it self-purges liquid contaminants, contains solid contaminants and improves the life of the trailer system components. Other Bendix products that work to help trailer air system are: the AF-3™ in-line air filter screens out foreign material from trailer air lines; and the System-Guard® trailer air dryer which removes moisture and contaminants from the trailer air system.

II. Mechanical Systems

General

Vehicle manufacturers must also comply with Government regulations for braking performance (e.g. U.S. FMVSS 121, Canadian CMVSS121). As with the air or pneumatic side of the system, the vehicle manufacturer must carefully design the brake geometry, size and power of the foundation brake components to achieve the desired vehicle performance. Maintenance personnel must likewise strive to maintain this performance.

Actuators

Brake chambers convert air pressure into mechanical force. Always maintain the chambers to their original performance condition. If chamber return springs need replacement, the springs should be replaced with springs of the proper spring load. When replacing, remember the chamber return spring affects the net force delivered by the chamber, and is especially important in low service brake applications. For this reason always replace the return spring on both chambers on an axle.

Chamber diaphragm life will vary according to the type of service and the diaphragm environment. Experience will generally dictate replacement frequency, and it is good practice to replace all diaphragms on the vehicle at the same time.

Also, in the case of S-Cam brakes, make sure the chamber push rods are in line with the slack adjusters. If misaligned, the chamber rod can rub on the chamber's non-pressure plate and cause a dragging brake.

Another factor that influences the brake chamber output force is the chamber push rod length. Ideally, the push rod length should be adjusted so that when the chamber reaches half its maximum stroke a 90 degree angle (approximately) is formed between the slack adjuster and chamber push rod.

Foundation Brakes

Braking torque is established by the vehicle manufacturer and is determined by the designed axle weight. Brake size (diameter), brake block or pad characteristics and the foundation brake design (S-Cam, air disc, etc.) influence brake torque. In the case of S-Cam brakes, the torque is carefully evaluated in relation to drum capacity, drum area, and lining area and in the case of air disc brakes, rotor/pad specifications. It is recommended that you consult the vehicle manufacturer before attempting any changes that would affect brake torque.

Mechanical friction within the foundation brake can affect brake output torque. The components of the foundation brake are subject to high forces and should be periodically checked and lubricated as necessary.

Friction material (e.g. brake block and lining segments, etc.) affect vehicle stopping performance and are a factor in wear balance from front to rear. Replacement material should be chosen for its stopping performance as well as wear characteristics. At a minimum, always replace friction material on both ends of an axle whenever one side is being serviced. For rear axles, it is recommended that friction material on all axles be replaced at one time.

With air disc brakes, the rotor-friction couple is carefully designed and validated for optimal performance. When replacing air disc brake pads, always select replacement pads that have been validated to perform with the rotor used, in order to prevent premature or uneven pad wear or damage to critical disc brake components (e.g. cracked rotors) which can adversely affect braking performance.

Brake Adjustment

One of the most important factors in obtaining maximum mechanical output of the chamber is proper brake adjustment. All chamber strokes should be adjusted to approximately the same stroke, and the adjustment should be made so that the chamber stroke is as short as possible without the brakes dragging. Improperly adjusted brakes waste air, reduce leverage and contribute to poor brake performance. In many cases, complaints of poor or insufficient braking power can be taken care of by proper brake adjustment.

Brake System Maintenance

Because no two vehicles operate under identical conditions, maintenance and maintenance intervals will vary. Experience is a valuable guide in determining the best maintenance interval for any one particular vehicle.

In Section 9, Air Brake System Troubleshooting, you will find some suggested tests for determining the overall condition of the air brake system and to help quickly locate problem areas. The tests check both leakage and device function. Performing these tests on a quarterly basis and recording the results of the tests in the vehicle maintenance records would provide a valuable basis for performance comparisons/trends and assist in deciding maintenance intervals.

Section 9: Air Brake System Troubleshooting Tests

Please follow all standard safety precautions, including, but not limited to, the general precautions listed on page 4 of this handbook.

TEST ONE

In this test we check the low pressure warnings, pressure buildup and governor cut-out and cut-in.

Park the vehicle and chock the wheels.

1. **Drain all reservoirs (air tanks) to 0 PSI.**
2. **Start the engine and run it at fast idle. Is the low pressure indicator buzzer working?**

OK Not OK

Observe the low pressure warning dash warning light - does it switch off at or above 60 PSI?

OK Not OK

Note: Some vehicles have alternate indicator devices. Also, on vehicles with antilock, the ABS indicator lamp will also come on momentarily when ignition is turned on.

Troubleshooting: If the low pressure warning light or buzzer doesn't come on: (a) Check the wiring and/or bulb, (b) Repair or replace the wiring, buzzer, bulb or low pressure indicator switch(es) as needed.

3. **Time how long it takes to build air pressure from 85 PSI up to 100 PSI. Does this take less than 40 seconds?**

OK Not OK

Troubleshooting: If build up time exceeds 40 seconds:

- (a) Examine the compressor air strainer and clean or replace as needed.
- (b) Check for a restricted inlet line if the compressor does not have a strainer, repair or replace as necessary.
- (c) Check compressor discharge port and line for excessive carbon (more than 1/16" coating). Clean or replace as necessary.

(d) With the air brake system charged, engine off and governor compressor in unloaded mode, listen for leakage at the compressor inlet. If leakage can be heard, apply a small amount of oil around the unloader pistons. If no leakage is indicated, then the leakage is through the compressor discharger valves.

(e) Check the compressor drive for slippage.

4. **Check vehicle manufacturer's recommendation for full air tank pressure. Does the governor cut-out at the correct pressure? (Typically between 100-130 PSI)**

OK Not OK

Troubleshooting: If the governor cut-out is higher or lower than specified by the vehicle manual:

(a) For adjustable governors, adjust using a temporarily-installed gauge of known accuracy. If the vehicle has a non-adjustable governor, replace it.

(b) See the Service Data sheet for the compressor to verify that the unloader mechanism is operating correctly before replacing governor.

5. **Reduce reservoir (air tank) pressure by repeatedly applying the service brakes until the governor cut-in. Is the difference between cut-in and cut-out pressure 25 PSI or less?**

OK Not OK

Troubleshooting: A difference of less than 25 psi indicates a malfunctioning governor. Replace the governor.

Retest to check out all items repaired or replaced.

Make all necessary repairs before proceeding to Test Two.

TEST TWO

Air Leakage

Inspect for air leaks when working on a vehicle and repair them promptly.

Park the vehicle on level ground and chock wheels. Build system pressure to governor cut-out and allow the pressure to stabilize for one minute.

Step 1: Observe the dash gauges for two additional minutes without the service brakes applied.

Step 2: Apply the service brakes and allow the pressure to stabilize. Continue holding for two minutes (you may use a block of wood to hold the pedal in position.) Observe the dash gauges. (Note: The Bendix® BVA-85™ brake valve actuator enables pre-trip brake inspections safely and easily with only one person. See page 46 for more details.)

If you see a decrease of the dash air gauge readings of more than:

- 4 psi for either service reservoir,
- 6 psi for a tractor/trailer combination,
- 8 psi for a tractor with two trailers,

during either two minute test, repair leaks and repeat this test to confirm that the air leaks have been repaired. NOTE: (A leak detector or soap solution will aid in locating the leak.)

Air leaks can also be found in the charging system, parking brakes, and/or other components (e.g. supply lines and fittings, low pressure indicator(s), relay valves, antilock modulators, dual brake valve, trailer control valve, park control valve, tractor protection valve, spring brake actuators, safety valve in supply reservoir, governor, compressor discharge valves) - inspect and repair as necessary.

Retest to check out all items repaired or replaced.

Make all necessary repairs before proceeding to Test Three.

TEST THREE

Brake chamber push rod travel

Check brake chamber push rod travel.

(Refer to chart for allowable tolerances)

Brake Chamber Size	Maximum Stroke Before Readjustment
12	1/8"
16	3/4"
20	3/4"
24	3/4"
30	2"

The angle formed between the brake chamber push rod and the slack adjuster arm should be approximately 90° with an 80-90 psi brake application (as measured with a test gauge either at the control gladhand or at the brake valve primary delivery). If the angle between the brake chamber push rod and the slack adjuster arm is not approximately 90° then adjust slack adjuster arm to obtain desired setting. If the brake chamber push rod travel exceeds the allowable tolerance, then adjust the adjuster arm to obtain the desired setting.

Retest to check out all items repaired or replaced.

Make all necessary repairs before proceeding to Test Four.

TEST FOUR

Parking Brake Application

Check with air system at full pressure, engine idling between 600-900 RPM

1. Manually operate the park control valve and note that parking brakes apply and release promptly as the control valve button is pulled out and pushed in.

For Tractor/Trailer Combinations:

(Do not use this test for a straight truck, buses, and bobtail tractors:)

1. Manually operate the tractor protection control valve (trailer supply valve usually red octagonal button). Note that the trailer brakes apply and release promptly as the control button is pulled out and pushed in.

2. Manually operate the system park control (usually yellow diamond button) and note all parking brakes (tractor and trailer) apply promptly.

If sluggish performance is noted in either test, check for:

1. Dented or kinked lines
2. Improperly installed hose fitting
3. A faulty relay emergency valve
4. A faulty modulator(s)

If the trailer brakes do not actuate and the trailer supply line remains charged, check the:

1. Tractor protection control
2. Trailer spring brake valve

Retest to check out all items repaired or replaced.

Make all necessary repairs before proceeding to Test Five.

TEST FIVE

Automatic Emergency System

Check with air system at full pressure, with the engine stopped.

1. Drain front axle reservoir to 0 PSI.
 - A. Rear axle reservoir should not lose pressure
 - B. On combination vehicles, the trailer air system should remain charged
 - C. Tractor and trailer brakes should not apply automatically
2. With no air pressure in the front axle reservoir make a brake application.
 - A. Rear axle brakes should apply and release
 - B. On combination vehicles the trailer brakes should also apply and release
 - C. The stop lamps should illuminate
3. Slowly drain rear axle reservoir pressure.
 - A. With the button out, supply either supply port with 120 psi of air. Then push the button in. The air pressure should rise in the delivery volume equivalent to supply pressure. Pull the button out. The delivery pressure should exhaust to 0 psi. Build each supply source to 120 psi and decrease supply pressure at the secondary service reservoir supply port at a rate of 10 psi per second. Primary supply pressure and delivery pressure should not

drop below 100 psi. Repeat the test for decreasing primary service reservoir pressure. Build each supply source to 120 psi. Then decrease both supply pressures to below 20 to 30 psi. The button should automatically "pop" out when pressure drops within that range.

- B. The tractor protection valve should close between 45 PSI and 20 PSI and the trailer supply hose should be exhausted
 - C. Trailer brakes should apply after tractor protection closes
4. Slowly drain the rear axle reservoir pressure.
 5. Close drain cocks, recharge the system and drain the rear axle reservoir to 0 PSI.
 - A. Front axle reservoir should not lose pressure
 - B. On combination vehicles the trailer air system should remain charged
 6. With no air pressure in the rear axle reservoir, make a brake application.
 - A. The front axle brakes should apply and release
 - B. On combination vehicles the trailer brakes should also apply and release
 - C. If the vehicle is equipped with an inverting relay spring brake control valve, the rear axle brakes should also apply and release

If the vehicle fails to pass the tests above, then check the following components for leakage and proper operation:

1. Fittings
2. Check for kinked hoses or tubing
3. Single check valves
4. Double check valves
5. Tractor protection valve
6. Tractor protection control valve
7. Parking control valve
8. Relay valves (antilock modulators)
9. Trailer spring brake control valve
10. Inverting relay spring brake control valve (optional on straight trucks and buses)

Retest to check out all items repaired or replaced.

Audio Visual Programs

Number to Order	Description	Package Quantity	Cost \$ Per Item	Format
Air Brake Systems				
BW1673	Four-part Video System Training with Workbooks .. set	1	30.00	VHS/Book
BW1678	Workbook for BW1673	5	2.00	Book
BW1957	Four-part Video only	1	15.00	VHS
BW2219	Vision systems installation	1	5.00	VHS
BW2324	Air Leakage	1	10.00	VHS

Brochures & Product Sheets
Actuating Devices

BW2116	Spring Brake	25	0	Product Sheet
--------	--------------------	----	---	---------------

Air Dryers

BW2023	AD-IP™ System-Guard® Air Dryer	25	0	Product Sheet
BW2075	PuraGuard® System Filter	25	0	Product Sheet
BW2076	EverFlow™ Air Dryer Control Module	25	0	Product Sheet
BW2088	AD-9™ System-Guard® Air Dryer	25	0	Product Sheet
BW2213	AD-IS™ Air Dryer	25	0	Product Sheet

Air Disc Brakes

BW2015	Air Disc Brakes	25	0	Brochure
--------	-----------------------	----	---	----------

AntiLock

BW2019	Truck/Tractor/Bus AntiLock Braking Systems	25	0	Product Sheet
BW2020	Trailer AntiLock Braking Systems	25	0	Product Sheet

Hydraulics

BW1399	Troubleshooting the Vacuum Hydraulic Brake System ..	25	0	Brochure
--------	--	----	---	----------

Modules

BW2096	Dryer Reservoir Module	25	0	Product Sheet
BW2132	Autobrake Product Sheet	25	0	Product Sheet

Slack Adjusters

BW1268	ASA-5™ Automatic Slack Adjuster	25	0	Brochure
BW1641	ASA-5™ Installation Template	10	0	Template
BW2216	SureStroke™ Indicator	25	0	Product Sheet

Valves

BW2047	Genuine Bendix Valves	25	0	Product Sheet
BW2197	BVA-85™ Brake Valve Actuator	25	0	Product Sheet
BW2215	Coreless™ Valves	25	0	Product Sheet

Vision

BW2245	Vision	25	0	Brochure
BW2246	Vision	25	0	Product Sheet

Catalogs/Service Manuals/CDs

BW1114	Quick Reference	25	0	Catalog
BW1419	FMSI Book	1	1.25	Catalog
BW2231	Truck Products Catalog	5	0	Catalog
BW9000	Air & Hydraulic Catalog Complete	1	15.00	Catalog
BW9001	Air & Hydraulic Complete Catalog w/o Binder	1	12.00	Catalog
BW9100	Air Parts Catalog Only	1	10.00	Catalog
BW9200	Hydraulic Parts Catalog Only	1	10.00	Catalog

Service Information

BW2031	Service Manual - CD	1	5.00	CD
BW5057	Air Brake Handbook	10	0	Handbook
BW9600	Service Data Manual Complete	1	15.00	SD



Number to Order	Description	Package Quantity	Cost \$ Per Item	Format
Binders				
BW1532	Empty Binder for Catalog, Service Manual & Bulletins	1	5.00	Catalog
Troubleshooting Cards & Wall Charts				
Systems-Air				
BW902	Bus System Wall Chart	3	1.25	Wall Chart
BW1555	Air Pressure Balance Test	10	0	Card
BW1231	Dual Systems Wallchart	3	1.25	Card
BW1396	Dual Systems Troubleshooting Card	25	1.25	Card
BW1397	Coach w/DD-3™ Park System & Coach w/Spring Brake Park System	25	1.25	Card
BW1779	Troubleshooting Charging & Air Supply Systems	25	1.25	Card
Systems-Hydraulic				
BW1398	Vacuum Hydraulic Wall Chart	3	1.25	Wall Chart
BW1611	Power Hyd. Brake Systems Wall Chart	3	1.25	Wall Chart
BW1705	Hydraulic Brake Booster System Card w/Troubleshooting	25	1.25	Card
AntiLock				
BW1742	MC-12™ Trailer AntiLock System Troubleshooting Card	25	1.25	Card
BW1959	MC-12™ Trailer ABS - Troubleshooting Card	50	2.50	Card
BW1982	EC-17™ Troubleshooting Card	50	2.50	Card
BW2175	EC-30™ Troubleshooting Card	25	1.25	Card
BW2187	MC-30™ Troubleshooting Card	25	1.25	Card
Cores				
BW1299	Core Group	3	0	Wall Chart
BW1330	Mini Core Chart	25	0	Wall Chart

Bendix reserves the right to limit quantities and cannot guarantee availability.

Service Data Sheets

Download from www.bendix.com, order (like parts) by BW number,
or order the complete Service Data Catalog (BW9600)

Device	SD number	(BW #)
A-18™ Trailer ABS		
(Gen 4™ and Gen 5™ ABS)	SD-13-4757	.. (BW2262)
A2LS™ Hydraulic Drum Brakes		
With Parking	SD-20-6608	.. (BW1601)
AD-1™ & AD-2™ Air Dryers	SD-08-2403	.. (BW1597)
AD-4™ Air Dryer	SD-08-2407	.. (BW1450)
AD-9™ Air Dryer	SD-08-2412	.. (BW1627)
AD-IP™ Air Dryer	SD-08-2414	.. (BW1811)
AD-IS™ Air Dryer	SD-08-2418	.. (BW2234)
AD-SP™ Air Dryer	SD-08-2415	.. (BW1777)
AF-3™ In-line Filter Assembly	SD-08-2401	.. (BW2263)
AH-1B™ Air Hydraulic Intensifier	SD-11-1326	.. (BW1599)
AH-4™ Air Hydraulic Intensifier	SD-11-1357	.. (BW1455)
Air Disc Brake	SD-23-7550	.. (BW2000)
Air Horns	SD-06-130	.. (BW1592)
AR-1™ Antilock Relay Valve	SD-13-4795	.. (BW1665)
AR-2™ Antilock Relay Valve	SD-13-4796	.. (BW1672)
ASA-5™ Automatic Slack Adjuster	SD-05-1269	.. (BW1602)
ATR-IDC™ Antilock Traction		
Relay Valve	SD-13-4811A	.. (BW1969)
ATR-1™ Antilock Traction		
Relay Valve	SD-13-4811	.. (BW1794)
ATR-2™ Antilock Traction		
Relay Valve	SD-13-4812	.. (BW1791)
BP-1™ Brake Proportioning Valve	SD-03-952	.. (BW1554)
BP-R1™ Bobtail Proportioning		
Relay Valve	SD-03-1067	.. (BW1624)
BX-2150™ Compressor	SD-01-331	.. (BW1424)
C-5™ Cut-Out Cock	SD-07-2601	.. (BW1596)
D-2™ Governor	SD-01-503	.. (BW1425)
DD3® & SD-3™ Safety Actuators	SD-02-4600	.. (BW1563)
Double Anchor Pin Cam Brakes	SD-22-3260	.. (BW1459)
Double Check Valves	SD-03-2202	.. (BW1846)
DRM™ Dryer Reservoir Module	SD-98-9808	.. (BW1948)
DuraFlo™ 596 Compressor	SD-01-670	.. (BW1845)
DV-2™ Automatic Reservoir		
Drain Valve	SD-03-2501	.. (BW1457)
E-10PR™ Retarder Control		
Brake Valve	SD-03-832	.. (BW2159)
E-12™ & E-15™ Dual Brake Valve	SD-03-826	.. (BW1622)
E-14™ Dual Brake Valve	SD-03-828	.. (BW1666)
E-2™ & E-3™ Brake Valve	SD-03-812	.. (BW1564)
E-5™ Dual Brake Valve	SD-03-816	.. (BW1565)
E-6™ & E-10™ Dual Brake Valve	SD-03-817	.. (BW1427)
E-7™ Dual Brake Valve	SD-03-818	.. (BW1428)
E-8P™ & E-10P™ Dual Brake Valve	SD-03-830	.. (BW2066)
EC-13™ Antilock Controller Assy	SD-13-4783	.. (BW1823)

Device	SD number	(BW #)
EC-14™ Antilock Controller Assy	SD-13-4784	.. (BW1670)
EC-15™ Antilock Controller Assy	SD-13-4785	.. (BW1663)
EC-16™ Antilock Traction ECU	SD-13-4787	.. (BW1726)
EC-17™ Antilock Traction ECU	SD-13-4788	.. (BW1910)
EC-30™ Antilock Traction ECU	SD-13-4815	.. (BW2160)
EC-60™ ABS/ATC Controllers	SD-13-4863	.. (BW2428)
ET-2™ Electronic Throttle	SD-15-4106	.. (BW1650)
ET-5™ & ET-52™ Suspended		
Electronic Treadles	SD-15-4111	.. (BW1837)
FD-1™ Fan Clutch	SD-09-8501	.. (BW1451)
FD-2™ Fan Clutch	SD-09-8503	.. (BW1598)
FD-3™ TorqueMaster Fan Clutch	SD-09-8504	.. (BW1452)
FD-L™ Fan Clutch	SD-09-8505	.. (BW1603)
Gen 4™ and Gen 5™ ABS for		
Trucks, Tractors, and Buses	SD-13-4746	.. (BW2261)
Hydro-Max Power Brake System	SD-20-6602	.. (BW1485)
IRV™ Inlet Regulating Valve	SD-01-3408	.. (BW1552)
LP-2™ & LP-3™ Low Pressure		
Indicators	SD-06-1600	.. (BW1447)
LQ-2™ Valve & TW-1™ Control		
Valve	SD-03-950	.. (BW1439)
LQ-3™ & LQ-4™ Front Axle Ratio		
Valves	SD-03-951	.. (BW1573)
LQ-5™ Bobtail Ratio Valve	SD-03-953	.. (BW1625)
M-12™ Antilock Modulator	SD-13-4772	.. (BW1669)
M-21™ Antilock Modulator	SD-13-4793	.. (BW1664)
M-30™ Antilock Modulator Assy	SD-13-4830	.. (BW2085)
M-32™ and M-32QR™ Antilock		
Modulator Assemblies	SD-13-4870	.. (BW2335)
Manual Slack Adjuster	SD-05-1200	.. (BW1453)
MC-11™ Trailer Antilock	SD-13-4761	.. (BW1671)
MC-12™ Trailer Antilock	SD-13-4762	.. (BW1667)
MC-30™ Trailer ABS Controller Assy	SD-13-4834	.. (BW2189)
MV-2™ Module Control Module	SD-03-3412	.. (BW1584)
MV-3™ Module Dash Control Module	SD-03-3415	.. (BW1613)
Piggyback Spring Brake	SD-02-4500	.. (BW2106)
PP-1™, PP-2™, PP-5™, PP-8™, &		
RD-3™ Push-Pull Type Control Valves	SD-03-3611	.. (BW1578)
PP-3™ Trailer Supply Valve	SD-03-3613	.. (BW1437)
PP-7™ Trailer Supply Valve	SD-03-3617	.. (BW1579)
PP-DC™ Park Control Valve	SD-03-3619	.. (BW1739)
PR-2™, PR-3™ & PR-4™ Pressure		
Protection Valves	SD-03-2010	.. (BW1440)
PuraGuard® QC™ Oil Coalescing Filter	SD-08-187B	.. (BW2396)
PuraGuard® System Filter	SD-08-187	.. (BW2084)
QR-IC™ Quick Release Valve		
w/Double Check	SD-03-904	.. (BW1585)

For the complete Service Data Sheet Catalog, order BW9600

Device	SD number	(BW #)	Device	SD number	(BW #)
QR-L™ Quick Release Valve – Inline	SD-03-906	..(BW1808)	TC-2™ Trailer Control Brake Valve	SD-03-813	..(BW1430)
QRN-2™ Quick Release Valve	SD-03-907	..(BW1786)	TC-4™ Modulating Control Valve	SD-03-4503	..(BW1566)
QR-N™ Quick Release Valve	SD-03-905	..(BW1586)	TC-6™ Trailer Control Brake Valve	SD-03-821	..(BW1567)
QRV™ & QR-1™ Quick Release Valve	SD-03-901	..(BW1442)	TC-7™ Trailer Control Brake Valve	SD-03-824	..(BW1568)
R-12DC™ Relay Valve with Biased			TE-1™ Trailer Emergency Stop Light		
Double Check	SD-03-1068	..(BW1933)	Switch	SD-06-1801	..(BW1595)
R-12P™ Pilot Relay Valve	SD-03-1063	..(BW1711)	TP-2™ Tractor Protection Valve	SD-03-3651	..(BW1436)
R-12™ & R-14™ Relay Valve	SD-03-1064	..(BW1431)	TP-3DC™ Tractor Protection Valve		
R-6™ Relay Valve	SD-03-1060	..(BW1432)	w/Double Check	SD-03-3656	..(BW1760)
R-7™ Modulating Valve	SD-03-4504	..(BW1445)	TP-3™ Tractor Protection Valve	SD-03-3652	..(BW1572)
R-8P™ Pilot Relay Valve	SD-03-1061A	..(BW1660)	TP-4™ Tractor Protection Valve	SD-03-3653	..(BW1438)
R-8™ Relay Valve	SD-03-1061	..(BW1569)	TP-5™ Tractor Protection Valve	SD-03-3655	..(BW1575)
RE-6™ & RE-6NC™ Relay			TR-2™, TR-3™ & TR-4™ Inversion		
Emergency Valves	SD-03-1151	..(BW1570)	Valves	SD-03-4650	..(BW1581)
Reservoirs	SD-04-400	..(BW1590)	Trailer System-Guard™ Air Dryer	SD-08-2416	..(BW2083)
RV-1™ Pressure Reducing Valve	SD-03-3510	..(BW1577)	Tu-Flo® 400, 500 & 1000 Compressors	SD-01-326	..(BW1420)
RV-3™ Pressure Reducing Valve	SD-03-3515	..(BW1587)	Tu-Flo® 501 Compressor	SD-01-337	..(BW1421)
RV-4™ Pressure Reducing Valve	SD-03-3520	..(BW1588)	Tu-Flo® 550 Compressor	SD-01-333	..(BW1639)
SC-1™ Single Check Valves	SD-03-2201	..(BW1441)	Tu-Flo® 600 Compressor	SD-01-336	..(BW1560)
SC-3™ In-Line Single Check Valve	SD-03-2205	..(BW1892)	Tu-Flo® 700 Compressor	SD-01-335	..(BW1422)
Single Anchor Pin Cam Brake	SD-22-3250	..(BW1458)	Tu-Flo® 750 Compressor	SD-01-344	..(BW1637)
SL-3™ & SL-4™ Stop Light Switches	SD-06-1800	..(BW1593)	TW-1™, TW-3™, TW-4™, TW-5™ &		
SL-5™ Switch & DS-2™ Stop Light			TW-6™ Two Way Control Valves	SD-03-3602	..(BW1580)
Switch & Combined Stop Light Switch &			TW-N™ Two Way Control Valve	SD-03-3672	..(BW1444)
Double Check Valves	SD-06-1804	..(BW1594)	Type 9, 12, 16, 20, 24 & 36 Brake		
SR-1™ Spring Brake Valve	SD-03-4508	..(BW1589)	Chambers	SD-02-1302	..(BW1426)
SR-2™ Trailer Spring Brake Valve	SD-03-4510	..(BW1435)	Type 9, 12, 16, 20, 24, 36 & 50		
SR-4™ Spring Brake Control Valve	SD-03-4514	..(BW1571)	Rotochambers	SD-02-1336	..(BW1561)
SR-5™ Trailer Spring Brake Valve	SD-03-4516	..(BW1680)	WS-20™ Antilock Wheel Speed Sensor	SD-13-4754	..(BW1662)
SR-7™ Spring Brake Modulating Valve	SD-03-9043	..(BW2271)	WS-24™ Antilock Wheel Speed Sensor	SD-13-4860	..(BW2364)
ST-1™ & ST-3™ Safety Valves	SD-03-1901	..(BW1583)	XVision® Vision System	SD-19-5160	..(BW2212)
SV-1™, SV-3™ & SV-4™ Synchro Valve &					
Trailer Release Valves	SD-03-4020	..(BW1574)			

Contact Bendix

For questions about troubleshooting, part number cross-reference, etc. call the Tech Team at 1-800-AIR-BRAKE or e-mail to TBS.TechTeam@bendix.com

See the Contacts area of www.bendix.com for contact information for Bendix dealers and distributors, Service Engineers, and Account Managers.

For ABS questions, please e-mail to ABS@Bendix.com.

For all other inquiries, please e-mail to info@bendix.com.

About Bendix Commercial Vehicle Systems LLC

We supply air brake charging and control systems and components, vehicle modules, and leading-edge safety technologies under the Bendix® brand name for medium- and heavy-duty trucks, tractors, trailers, buses and other commercial vehicles in North America, Europe and Australia. Employing more than 1,800 people, Bendix is headquartered in Elyria, Ohio, with manufacturing plants in the U.S. and Mexico.

We are part of a global organization with technical and manufacturing centers worldwide, and remain on the leading edge of new product development and applications engineering.

Bendix products are backed by our TechTeam - a team of air brake experts who staff our 1-800-AIR-BRAKE (1-800-247-2725) hotline.

We also invite you to visit www.bendix.com for all the latest information on our products.

Our Service Engineers provide on- and off-site technical training. See the Training area of bendix.com for a list of current dates and locations.

A Brief History of Bendix Commercial Vehicle Systems LLC

- 1869: Westinghouse Air Brake Company established in Wilmerding, Pa., to manufacture air brakes invented by George Westinghouse.
- 1924: Westinghouse air brake system (including Broussouse compressor) applied to International Harvester Coach in Akron, Oh.
- 1927: Bendix Corporation formed by automotive engineer Vincent Bendix. Company produces "Safety Servo" vacuum brake under the Braggs-Kliesrath name.
- 1930: Bendix-Westinghouse Automotive Air Brake Company established following the merger of Bendix Corp. and Westinghouse Automotive Air Brake. Headquarters located in Wilmerding, Pa.
- 1934: Bendix-Westinghouse takes automotive air brake worldwide by establishing licensing agreements with Westinghouse companies in France, Germany, Italy and England.
- 1941: Bendix-Westinghouse establishes new headquarters in Elyria, Oh.
- 1949: WWII accelerates developments, and air braking becomes standard on all heavy trucks, tractor-trailers, buses, fire trucks and off-highway vehicles.
- 1960: Automatic slack adjusters, air dryers, dual brake valves and first generation antilock braking systems are under development.
- 1969: Bendix Corporation acquires 100 percent ownership of Bendix-Westinghouse.
- 1973: Bendix-Westinghouse becomes Bendix Heavy Vehicle Systems Group, a division of Bendix Corporation.
- 1975: Bendix dual air brake system becomes standard for the National Highway Traffic Safety Administration's Federal Motor Vehicle Safety Standard (FMVSS) 121.
- 1980: Bendix establishes worldwide parts distribution center and remanufacturing operation in Huntington, In.
- 1982: Bendix Corporation merges with Allied Corporation and the division becomes an operating unit of Allied Automotive, an independent supplier to the worldwide automotive industry under the brand names of Bendix®, Fram® and Autolite®.
- 1986: The Bendix Heavy Vehicle Systems Group of Allied merges with Bendix Limited European truck air brake operation establishing Bendix Heavy Vehicle Systems Group-Europe. Allied Corporation acquires Signal operations establishing AlliedSignal Inc. as the division's parent company.
- 1989: Bendix Heavy Vehicle Systems Group-Europe acquires truck air brake operation of Magneti Marelli, strengthening European operations.
- 1999: AlliedSignal merges with Honeywell International. The new company continues to offer Bendix® brand name air brake and control systems and components under its Honeywell Commercial Vehicle Systems unit. Honeywell operates Honeywell Commercial Vehicle Systems as a joint venture with Knorr-Bremse AG of Munich, Germany. Honeywell owns 65 percent of the unit. Knorr-Bremse owns 35 percent.
- 2002: Knorr-Bremse assumes 100 percent ownership of Honeywell Commercial Vehicle Systems from Honeywell International Inc. The company changes its legal name to Bendix Commercial Vehicle Systems LLC.