

# CENTERLINE 2100 Motor Control Centers Joining and Splicing Vertical Sections

Bulletin Number 2100

Topic	Page
Required Tools	2
Joining MCCs	2
Splicing MCCs	8
Splicing Procedures	9
Torque Specifications and Table	15
Additional Resources	15

These instructions illustrate the recommended procedures to use when joining and splicing CENTERLINE® 2100 motor control centers (MCCs). For more splicing information related to specific MCCs, see the bus splice illustration that is included in the documentation that is shipped with the MCC.



**ATTENTION:** De-energize all power sources to the motor control center before joining and splicing vertical sections. Failure to de-energize all power sources can result in severe injury or death.

Review your company safety lockout and tag-out procedure.

All covers and doors must be in place before you apply power to the MCC. If units are removed, they must be replaced with the appropriate items, such as units, doors, and unit support pans.

**IMPORTANT** If you use NO-OX-ID corrosion inhibitor on the busbars, do not get any of the inhibitor on the bus splice hardware. The corrosion inhibitor does not let you properly torque the hardware. Damage can occur.

## Summary of Changes

This publication contains new insulated bus splice information.

## Required Tools

These tools are required for joining and splicing your MCC sections:

- Assorted screwdrivers
- Sockets (including 9/16" deep well and 5/16" sockets)
- Torque wrench

## Joining MCCs

To join motor control center vertical sections, follow these procedures.

### NEMA 1, 1G, and 12

Physical restrictions at your installation do not allow the following sequence to be followed exactly as stated. The splice kit, if necessary, is located within a horizontal wireway or blank unit space. On six space factor frame-mounted units, the splice kit is within the unit. A fluorescent pink, removable label (on the outside of the compartment) designates the location.

1. Locate splice kits and set aside for later use.
2. Remove top and bottom horizontal wireway covers as shown in [Figure 2](#) and [Figure 3](#).
3. Remove the wood shim used in transportation from the side of the MCC.
4. Remove top, bottom, and center end closing plates, if present, to expose joining holes (referred to as A and B in [Figure 2](#) and [Figure 3](#)) of the MCC.

Joining holes that are not covered by end closing plates can contain 1/4-20 hex head thread-forming screws on the left side and removable plastic plugs on the right side. These screws and plugs are accessible both from within the vertical wireway and from the outside surface of the vertical side plate. The screws and plugs must be removed from the side plates to be joined. See [Figure 2](#) and [Figure 3](#).

5. Remove the vertical wireway cover and horizontal bus splice access cover from the sections to be joined.  
See [Figure 1](#) and [Figure 7](#) for location.
6. Pull all 'bottom entry' cables, if any are present, through the conduits to a point where they are accessible when the MCC is positioned.

---

**IMPORTANT** For NEMA 12 MCCs, see NEMA 12 Sealing Instructions, publication [2100-IN037](#). This publication is shipped with the splice kit.

---

7. Slide sections together, make sure that cabinets are level, and that the holes in side sheets line-up with adjacent holes.  
See [Figure 2](#) for location.

---

**IMPORTANT** Make sure that cabinets are level and pushed together, tightly. Do not use hardware to draw cabinets together.

---

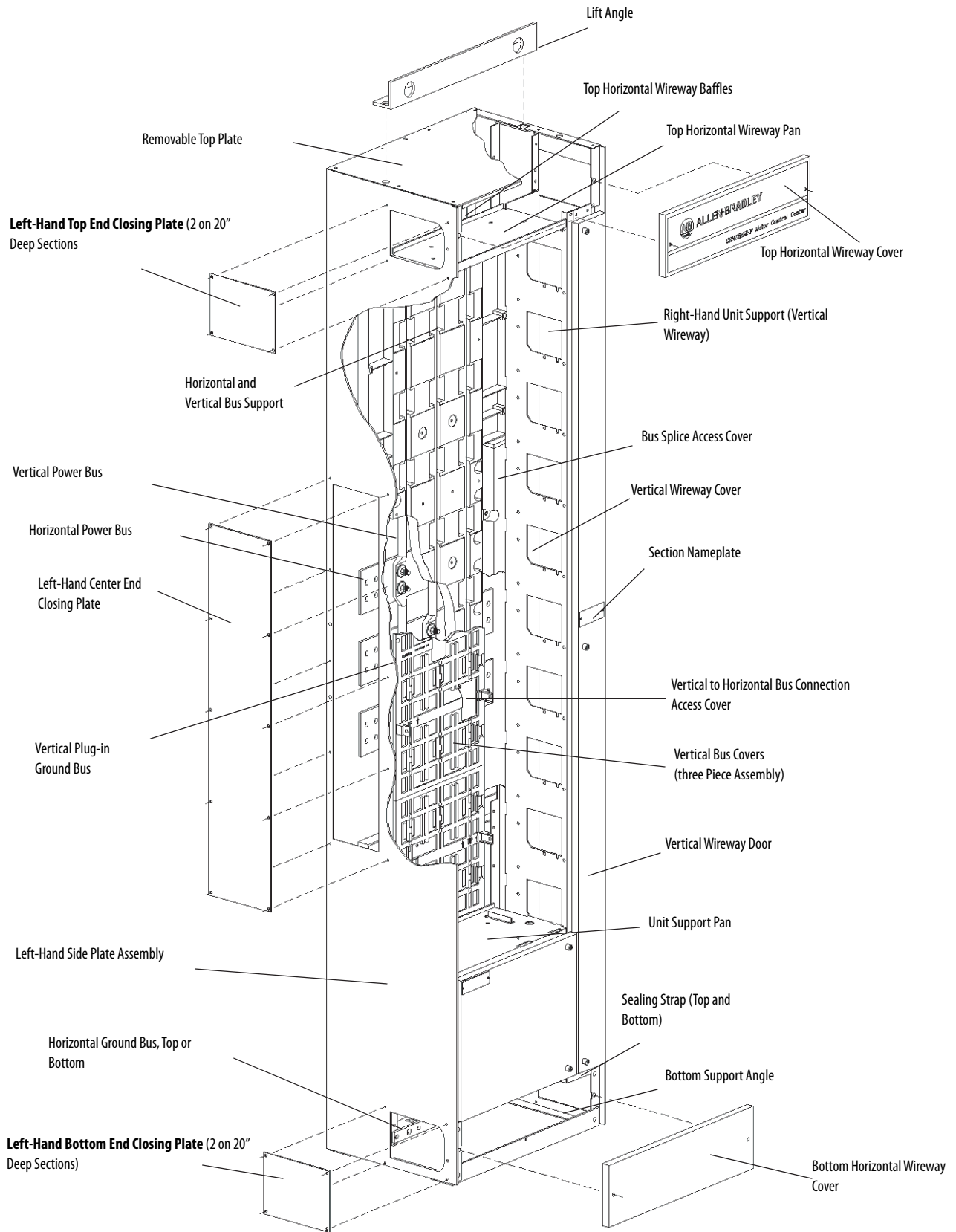
8. Join the two MCCs by using the hardware furnished with the splice kit.
  - Pass the 1/4-20 hex head thread-forming screw from inside the left MCC through joining holes (A in [Figure 2](#) and [Figure 3](#)) and engage the screws with the holes that are located in the right center. See [Torque Requirements on page 15](#).
  - Pass the 1/4-20 x 5/8 hex screw from inside the left center through joining hole (B in [Figure 2](#) and [Figure 3](#)) and secure with the 1/4-20 steel nut. See [Torque Requirements on page 15](#).
9. Secure the MCC to the floor as required by local code.
10. Inspect the interior for dust and dirt.  
We recommend that you use a vacuum cleaner to clean the interior of the MCC.

---

**IMPORTANT** Do not clean by using compressed air. It contains moisture and can blow debris into the control equipment.

---

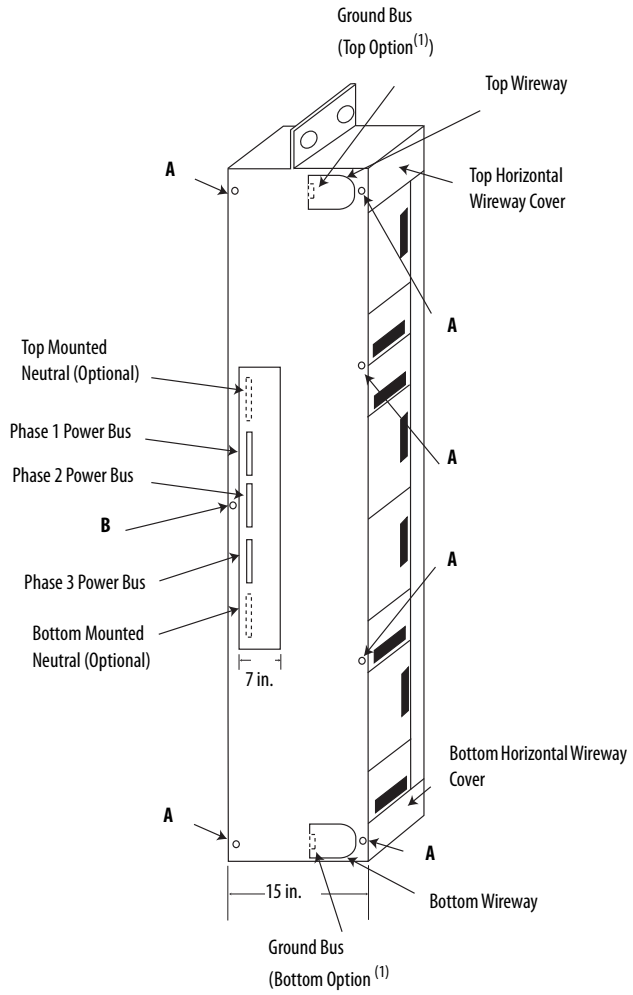
**Figure 1 - Typical 15" Deep MCC Construction**



**Figure 2 - Example of 15" Deep MCC**

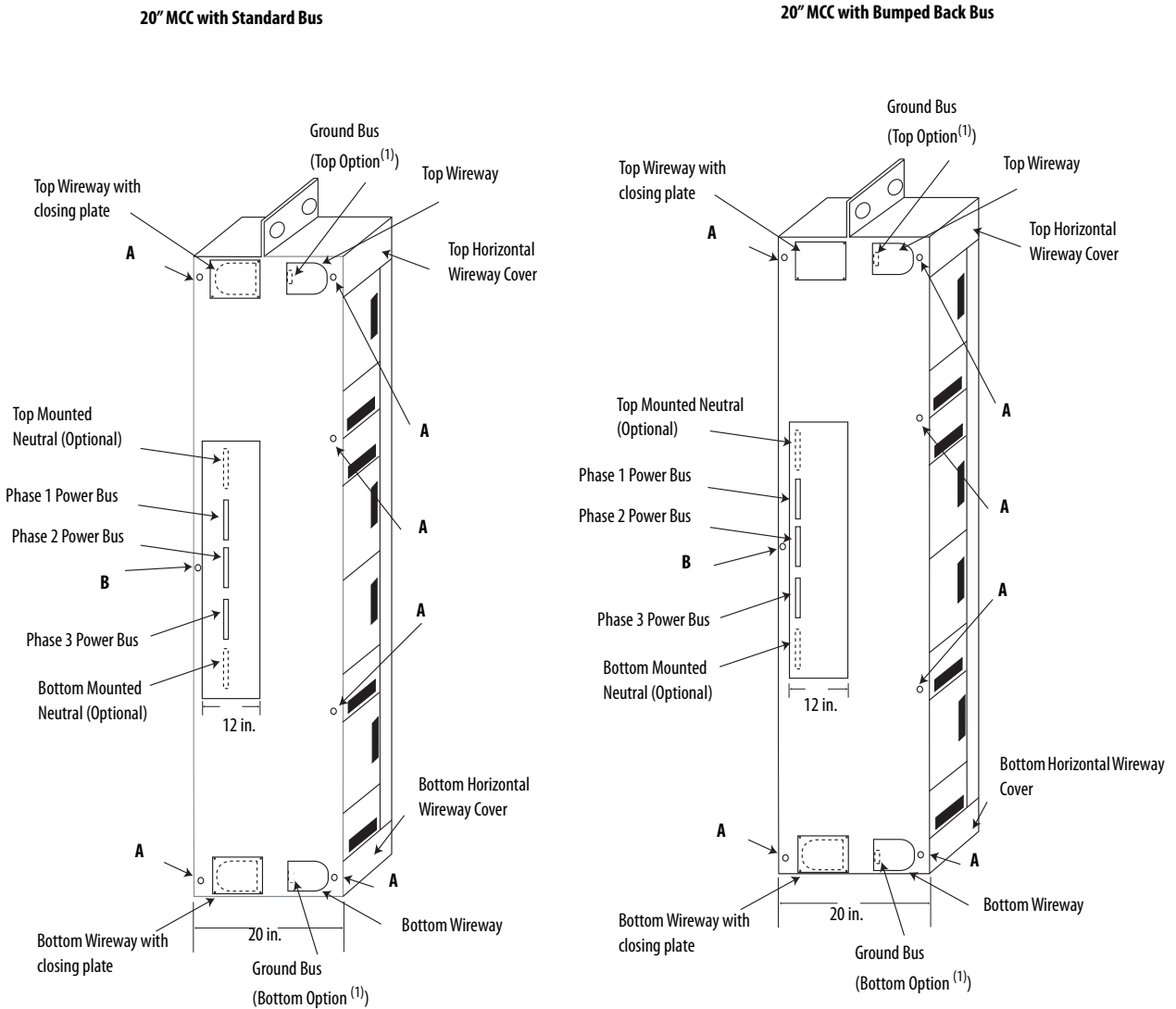
- A - Use a 1/4-20 hex head thread-forming screw
- B - Use a 1/4-20 x 5/8 hex screw and secure with a 1/4-20 steel nut

See [Torque Requirements on page 15](#).



(1) Ground bus is required. The ground bus can be in the bottom, top, or bottom and top.

Figure 3 - Example of 20" Deep MCCs



- A - Use a 1/4-20 hex head thread-forming screw
- B - Use a 1/4-20 x 5/8 hex screw and secure with a 1/4-20 steel nut

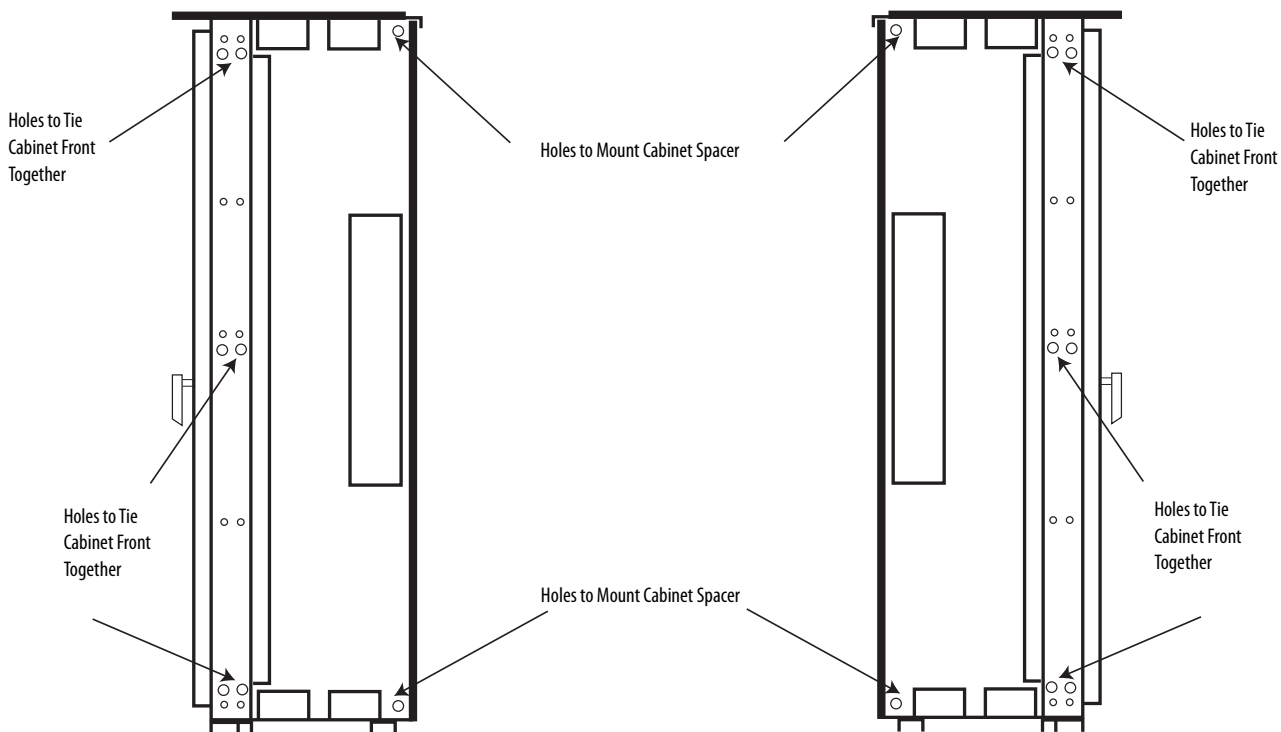
See [Torque Requirements on page 15](#).

(1) Ground bus is required. The ground bus can be in the bottom, top, or bottom and top.

### NEMA 3R and 4

1. Remove 3R/4 side sheet from end of section, being spliced, if present (3R End Closing Plate), see [Figure 5](#) for details.

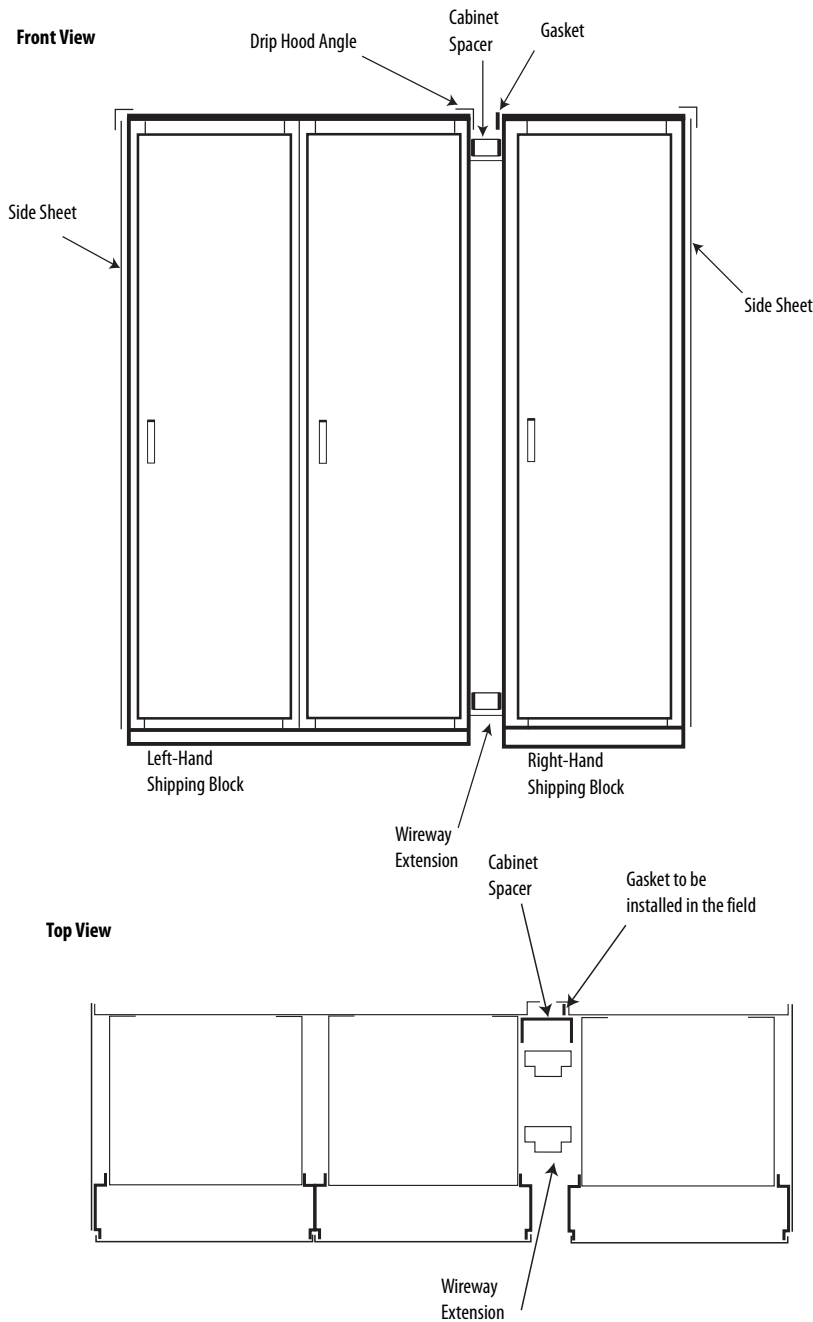
**Figure 4 - NEMA 3R/4 without Side Sheet.**



2. Mount cabinet spacer (supplied with Splice Kit) to right-hand shipping block, by using 1/4 - 20 X 3/4" thread-forming screws.
3. Insert the thread-forming screws through large hole in cabinet spacer and bolt to cabinet.

See [Figure 4](#) and [Figure 5](#) for location and [Torque Requirements on page 15](#).

**Figure 5 - NEMA 3R/4**



4. Remove drip hood angle from shipping block being spliced, see [Figure 5](#).
5. Install gasket (supplied with splice kit) on back plate and top plate (if not present on cabinet), see [Figure 5](#).
6. Slide sections together, make sure that cabinets are level, and cabinet spacers and holes in front flange lines-up with adjacent holes, see [Figure 5](#).
7. Install 1/4-20 X 3/4" thread-forming screws through left-hand shipping block side-plate into cabinet spacer.  
These holes are accessed through the top and bottom horizontal wireways. See [Torque Requirements on page 15](#).

---

**IMPORTANT** Make sure that cabinets are level and pushed tight together. Do not use hardware to draw sections together.

---

8. To secure sections together, install six 1/4-20 X 3/4" thread-forming screws in the front flange.  
Screws must be installed from the left shipping block through into the right block. This area can be accessed by opening the NEMA 3R/4 doors. See [Figure 4](#) for details. See [Torque Requirements on page 15](#).
9. Replace the drip hood angle removed in Step 3.
10. Make sure that hardware is inserted through the drip angle and clearance hole in top plate before threading into adjacent top plate.  
See [Torque Requirements on page 15](#).
11. Install Wireway extensions.
  - a. From top and bottom wireway in right-hand shipping block, insert extension through wireway opening and hook lip on wireway opening of left-hand section.
  - b. To secure extension to the wireway opening in the right-hand section, install 1/4-20 X 1/2" thread-forming screw in wireway extension.  
This extension does not bolt into the cabinet, but is clamped onto the wireway opening. See [Figure 5](#) for details.

## Splicing MCCs

A main horizontal-bus splice kit must be added between the horizontal bus work of the MCCs. In addition, the neutral bus splice kit, if necessary, and the ground bus splice kit must be installed to complete the splicing operation. See [Splicing Procedures on page 9](#) for instructions.

To gain access to the horizontal bus, remove the plug-in units in front of the horizontal bus in the first vertical section of the right center.

## Plug-in Unit Removal

To complete plug-in unit removal, see Installing Units with Horizontal Operating Handles, publication, [2100-IN060](#), and Installing Units with Vertical Operating Handles, publication [2100-IN014](#).

The following is an overview of the removal process for a plug-in unit:

1. Open unit door by turning door latch a quarter turn.  
**TIP** Door removal is not necessary when removing a unit; however, if door removal is desired, follow these steps. [Step b](#) can be required even if the door is not removed.
2. Remove the unit door.
  - a. Open the door fully.
  - b. If present, remove control station housing by loosening the two captive screws that are at the top and bottom of the control station housing on the front of the unit door.
  - c. To remove the hinge pins, use a screwdriver to slide up the pins.
  - d. Swing door to near closed position and lift off the door.
3. Loosen the screw type latches at the front of the unit.  
Most units have one at the top and one at the bottom, but units two space factors and larger have two at the top.
4. Detach necessary wiring from unit.
5. Place wire/terminal block in line with wiring clearance tunnel at lower right of unit.
6. Pull unit forward to unplug from bus, by using the upper right latch assembly and the lower left tab handle.
7. Remove the unit support pan, see [Figure 6](#).
  - a. Use a screwdriver to pry the plastic retaining clip from the right side of the support pan.  
The clip is visible in the vertical wireway.
  - b. Lift the right side of pan approximately 4 inches.
  - c. Pull right side of pan forward to release from left rear slot.
  - d. Push back on left side of pan until it is free.

**Figure 6 - Removal of Support Pan**

## Splicing Procedures

To splice vertical sections together, follow these steps.

1. Remove the horizontal bus splice access cover to expose the horizontal bus splicing, see [Figure 7](#).

**Figure 7 - Bus Splice Access Cover**

Bus Splice Access Cover In Place



Bus Splice Access Cover Removed

2. Assemble splice bars to the bus work of the vertical sections as shown in [Figure 8](#)...[Figure 15](#).
3. If additional access to the splice is desired, loosen the fastening screws and remove the bus access plate that is in the vertical wireway of the center (to the left of the splice).

The horizontal bus now is exposed to the left and right of the splice for added convenience. The splicing kit contains either two or four sets of hardware per splice bar, depending on the current rating of the horizontal bus.

4. See [Bus and Splice Bar Dimensions \(Series P and earlier\) on page 14](#) for bus dimensions and mounting holes.
5. Tighten to the torque specifications listed in the [Torque Requirements on page 15](#).

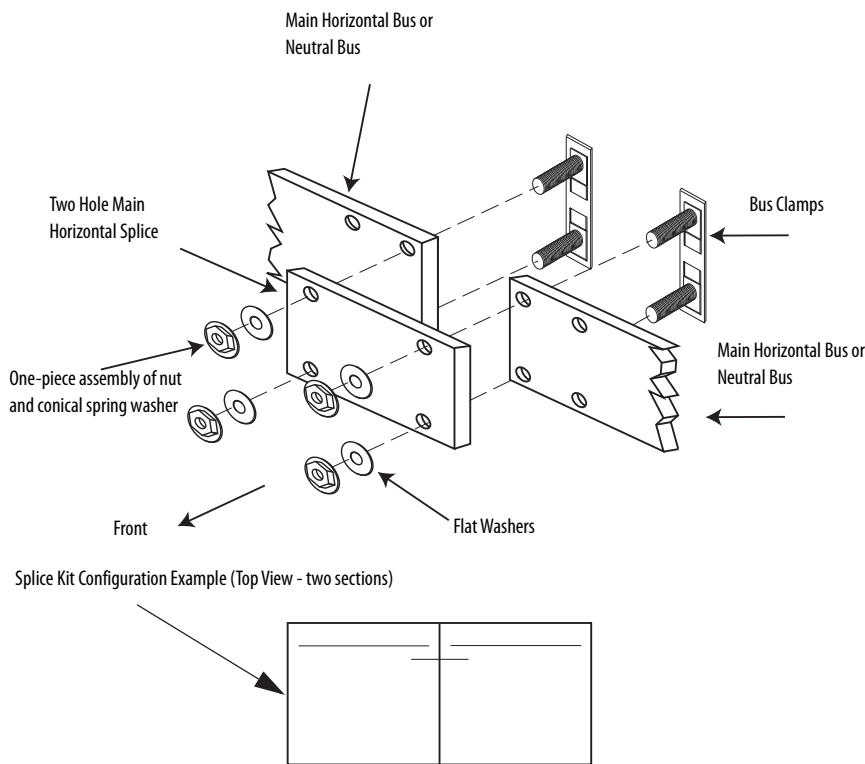
**IMPORTANT** Do not grease or lubricate the mounting hardware.

6. Optional, install the insulating components.  
See CENTERLINE 2100 Motor Control Centers Insulated Bus Splice Installation Instructions, publication [2100-IN096](#) for information regarding installation of the insulating components.
7. Replace covers and plates and check all bolts and nuts for tightness.
8. Replace units in their respective stations.



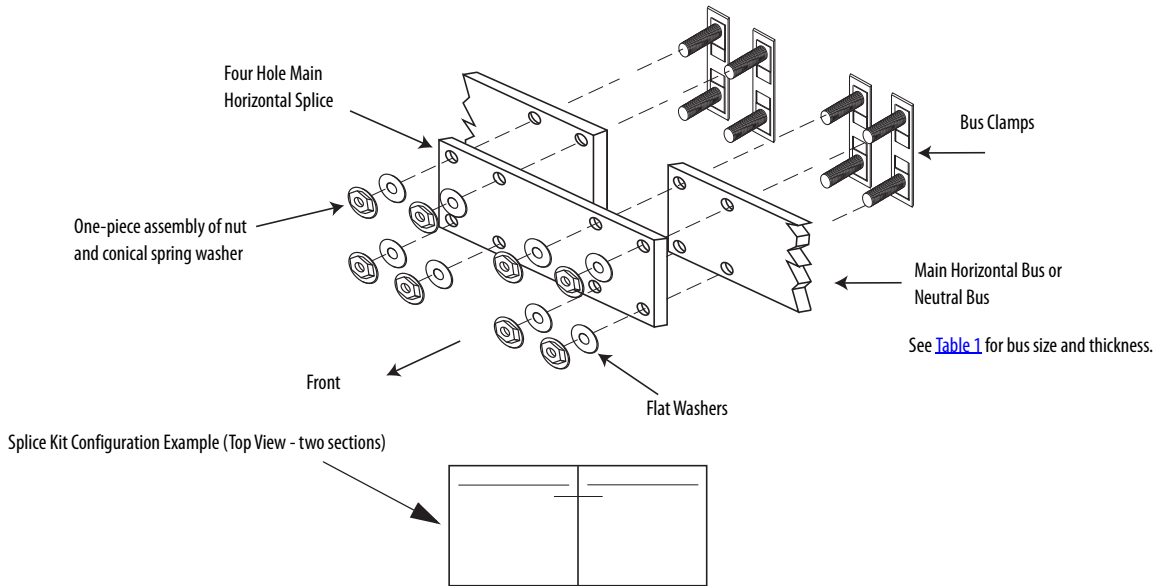
**ATTENTION:** All covers and doors must be in place before you apply power to the MCC. If units are removed, they must be replaced with the appropriate items, such as units, doors, and unit support pans.

**Figure 8 - 600...1200 Amp Main Horizontal Bus Splicing Detail and Configuration Example**

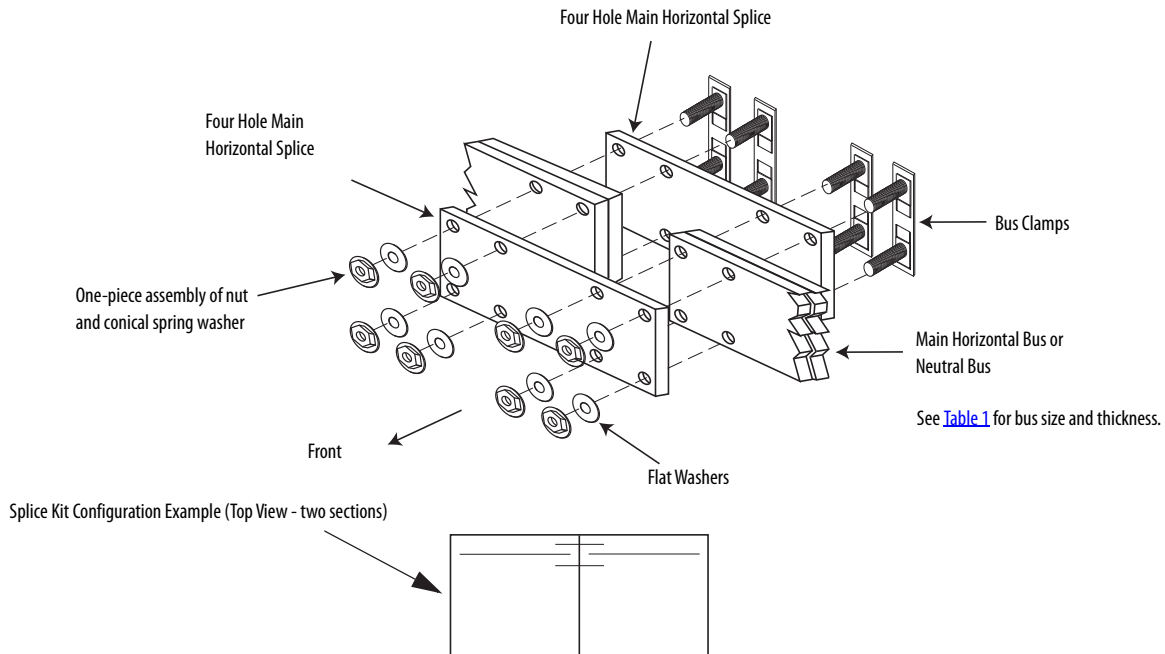


See [Table 1](#) for bus size and thickness.

**Figure 9 - 800...1200 Amp Insulated Horizontal Bus Splicing Detail and Configuration Example**

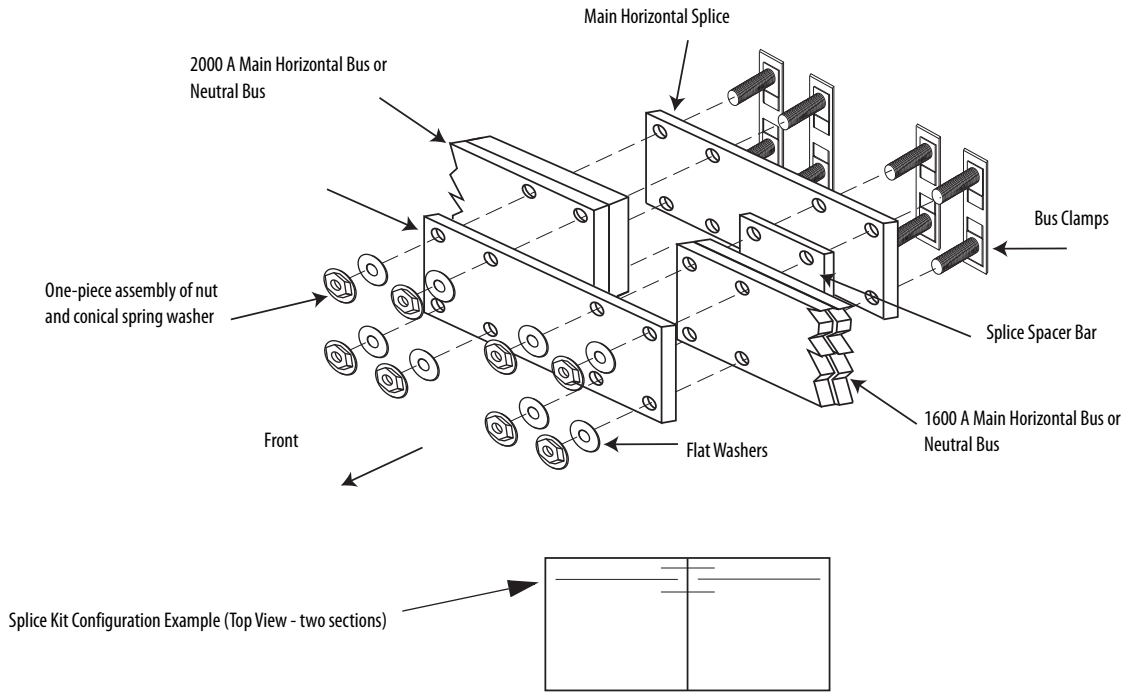


**Figure 10 - 1600...3000 Amp Horizontal Bus Splicing Detail and Configuration Example**



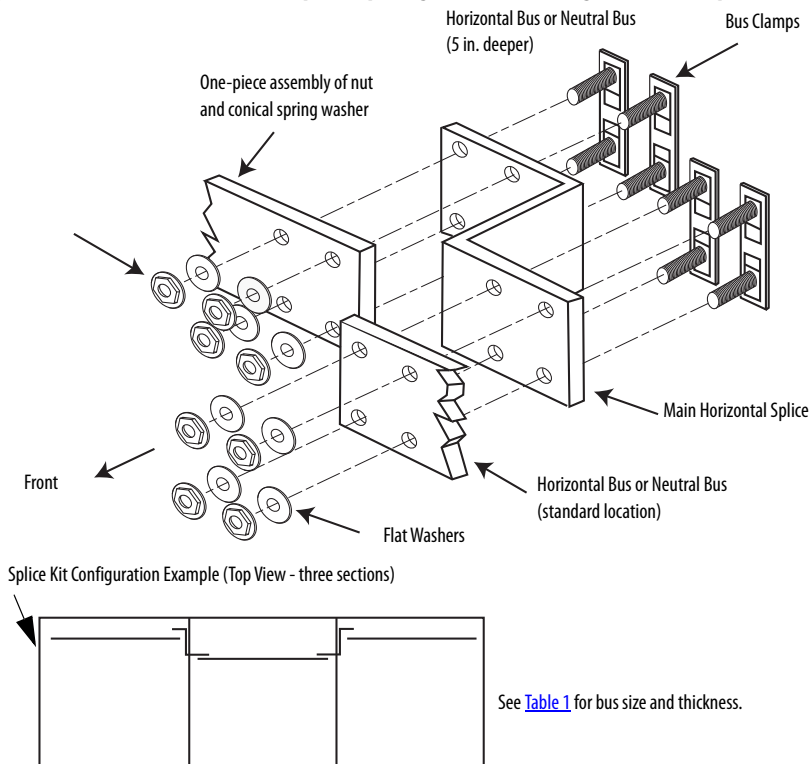
**TIP** For 1600 A Insulated bus solutions in 15" deep sections, angle and pivot the longer bus clamps into position for easier installation.

**Figure 11 - 2000 Amp Main Breaker and 1600 Amp Horizontal Bus Splicing Detail and Configuration Example**



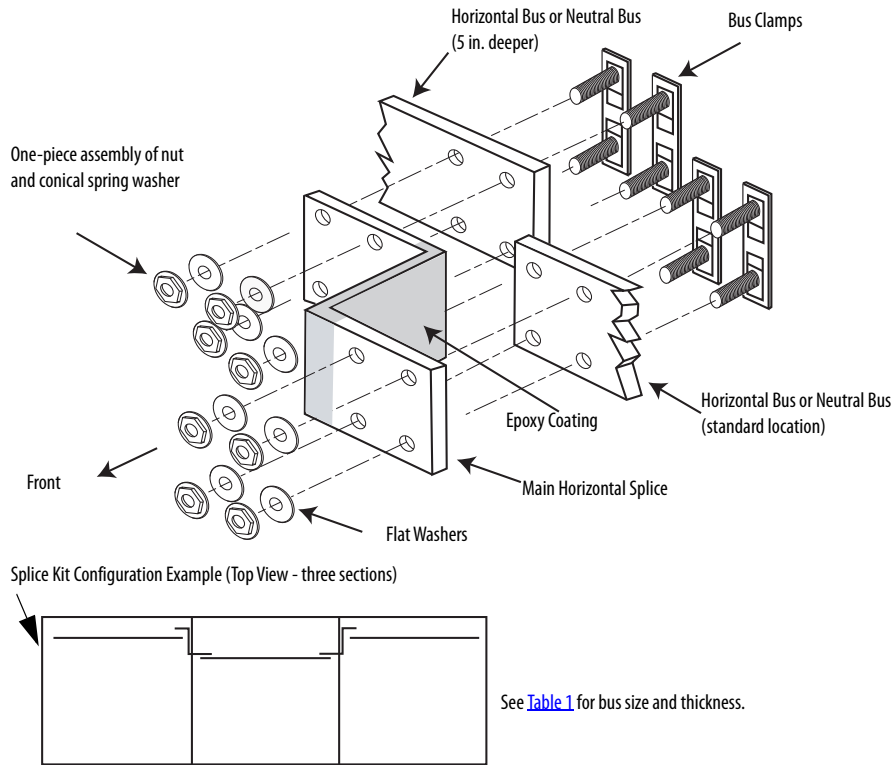
See [Table 1](#) for bus size and thickness.

**Figure 12 - Offset 'Z' 600...1200 Amp Bus Splicing Detail and Configuration Example**

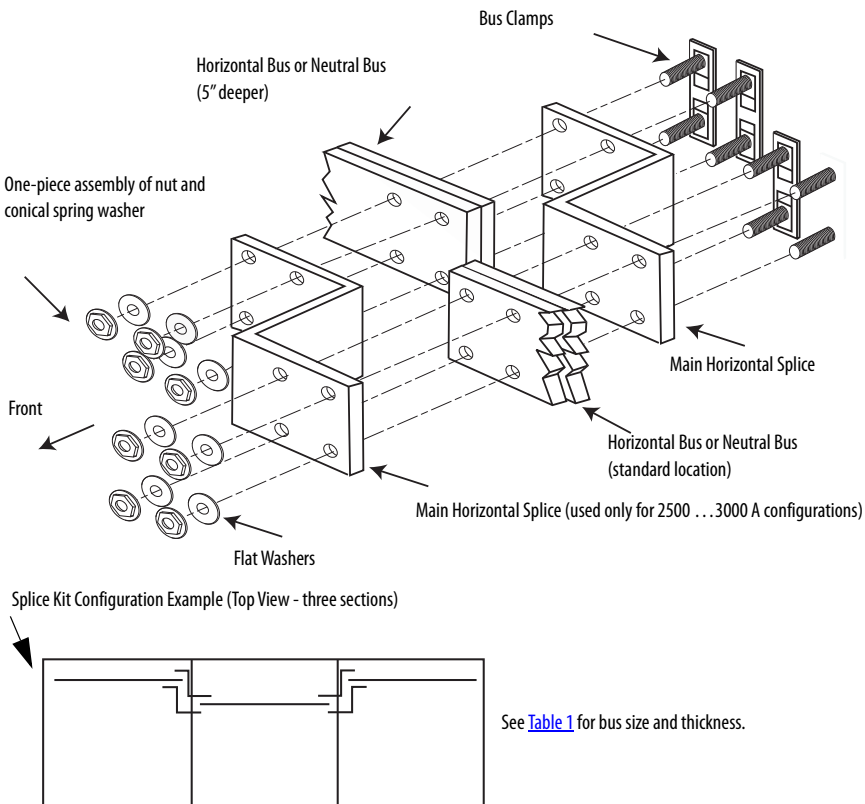


See [Table 1](#) for bus size and thickness.

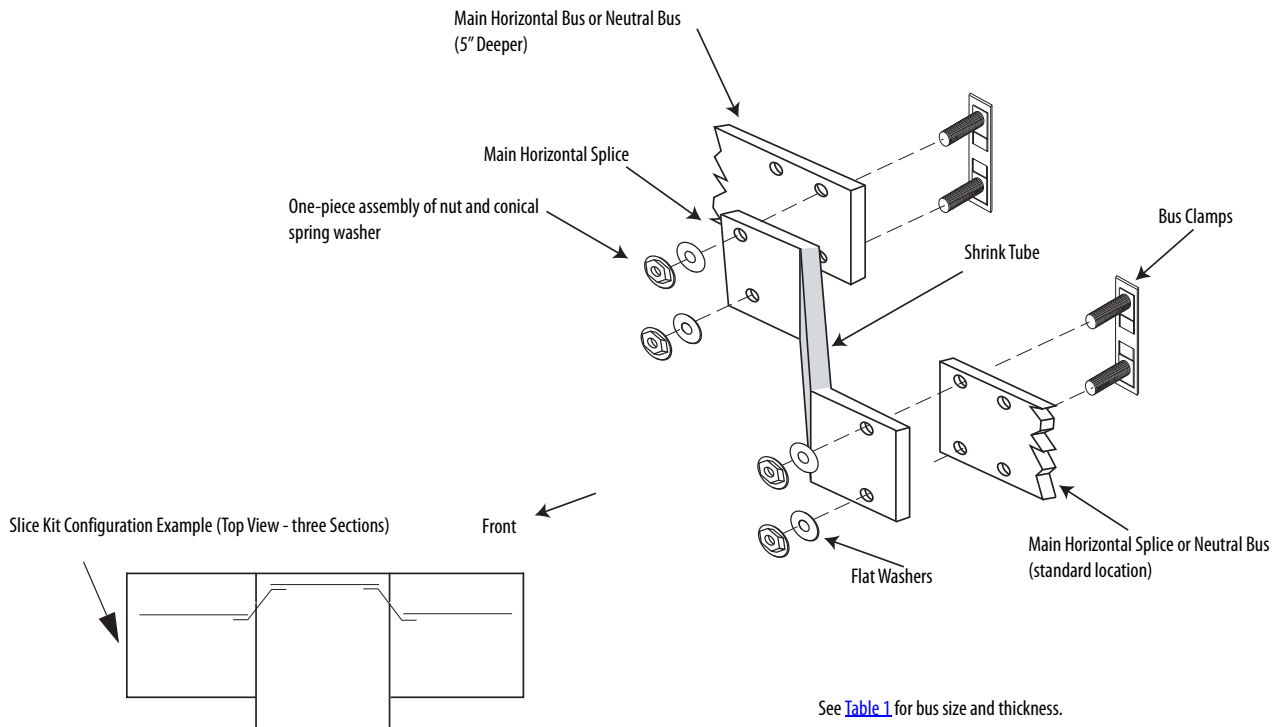
**Figure 13 - Offset 'Z' 800...1600 Amp Insulated Bus Splicing Detail and Configuration Example**



**Figure 14 - Offset 'Z' 1600...3000 Amp Bus Splicing Detail and Configuration Example**



**Figure 15 - 25 in. Deep 'Z' 600...1200 Amp Bus Splicing Detail and Configuration Example**



See [Table 1](#) for bus size and thickness.

**Table 1 - Bus and Splice Bar Dimensions (Series P and earlier)**

Standard NEMA 1, 1G, 12, and 3R/4 Splice Bar Information							
Amp	Material	Quantity	Thickness, in.	Width, in.	Splice Mounting Holes	Straight Splice	Z-splice <sup>(1)</sup>
600	Copper	1	0.125	3	2	X	
	Aluminum	1	0.125	4		X	
800	Copper	1	0.125	4	2	X	X
	Aluminum	1	0.1875			X	X
800 Insulated	Copper	1	0.250	4	4	X	X
1200	Copper	1	0.250	4	2	X	X
1200 Insulated	Copper	1	0.250	4	4	X	X
1600	Copper	2	0.250	4	4	X	
	Copper	1	0.500	4	4		X
1600 Insulated	Copper	2	0.500	4	4	X	
	Copper	1	0.500	4	4		X
2000	Copper	1	0.250	4	4	X	
		1	0.375			X	
	Copper	1	0.625	4	4		X
2500/3000	Copper	2	0.375	4	4		X

(1) Used to splice standard depth bus to bus 5 in. deeper.

## Torque Specifications and Table

**Table 2 - Conversions**

Decimal, in.	Fraction, in.	Millimeter, mm	Decimal, in.	Fraction, in.	Millimeter, mm
0.125	1/8	3.175	0.375	3/8	9.525
0.250	1/4	6.350	0.625	5/8	15.875
0.500	1/2	12.700	3	3	76.200
.1875	3/16	4.763	4	4	101.600

Tighten all bus connections with a torque wrench and socket according to intervals established by your maintenance policy. Do not grease or lubricate the hardware.

**Table 3 - Torque Requirements**

Description	Torque
Lug attachment bolts 1/2-13 Hardware	45 lb•ft ± 5 lb•ft (61 N•m ± 6 N•m)
Horizontal to vertical bus connection 3/8-16 Hardware	28 lb•ft ± 4 lb•ft (38 N•m ± 5 N•m)
Horizontal splice connection 3/8-16 Hardware	28 lb•ft ± 4 lb•ft (38 N•m ± 5 N•m)
Connecting Hardware 1/4-20 Hardware	55 lb•in. ± 5 lb•in (6.2 N•m ± 0.6 N•m)
10-32 Hardware	32 lb•in ± 3 lb•in (3.6 N•m ± 0.4 N•m)

## Additional Resources

These documents contain additional information concerning related products from Rockwell Automation.

Resource	Description
CENTERLINE 2100 Low Voltage Motor Control Centers Instruction Manual, publication, <a href="#">2100-IN012</a> .	Provides general instructions for MCC Units.
CENTERLINE 2100 Motor Control Centers (MCC) Units with Vertical Operating Handles Installation Instructions, publication <a href="#">2100-IN014</a> .	Provides information on installing vertical handle units.
CENTERLINE 2100 Motor Control Center (MCC) Units with Horizontal Operating Handles Installation Instructions, publication <a href="#">2100-IN060</a> .	Provides information to install units with horizontal operating handles.
Busbar Insulation Components Installation Instructions, publication <a href="#">2100-IN096</a> .	Provides instructions to install the insulation components.
Industrial Automation Wiring and Grounding Guidelines, publication <a href="#">1770-4.1</a> .	Provides general guidelines for installing a Rockwell Automation industrial system.
Product Certifications website, <a href="http://rok.auto/certifications">rok.auto/certifications</a> .	Provides declarations of conformity, certificates, and other certification details.

You can view or download publications at <http://www.rockwellautomation.com/global/literature-library/overview.page>.

# Rockwell Automation Support

Use the following resources to access support information.

<b>Technical Support Center</b>	Knowledgebase Articles, How-to Videos, FAQs, Chat, User Forums, and Product Notification Updates.	<a href="https://rockwellautomation.custhelp.com/">https://rockwellautomation.custhelp.com/</a>
<b>Local Technical Support Phone Numbers</b>	Locate the phone number for your country.	<a href="http://www.rockwellautomation.com/global/support/get-support-now.page">http://www.rockwellautomation.com/global/support/get-support-now.page</a>
<b>Direct Dial Codes</b>	Find the Direct Dial Code for your product. Use the code to route your call directly to a technical support engineer.	<a href="http://www.rockwellautomation.com/global/support/direct-dial.page">http://www.rockwellautomation.com/global/support/direct-dial.page</a>
<b>Literature Library</b>	Installation Instructions, Manuals, Brochures, and Technical Data.	<a href="http://www.rockwellautomation.com/global/literature-library/overview.page">http://www.rockwellautomation.com/global/literature-library/overview.page</a>
<b>Product Compatibility and Download Center (PCDC)</b>	Get help determining how products interact, check features and capabilities, and find associated firmware.	<a href="http://www.rockwellautomation.com/global/support/pcdc.page">http://www.rockwellautomation.com/global/support/pcdc.page</a>

## Documentation Feedback

Your comments will help us serve your documentation needs better. If you have any suggestions on how to improve this document, complete the How Are We Doing? form at [http://literature.rockwellautomation.com/idc/groups/literature/documents/du/ra-du002\\_-en-e.pdf](http://literature.rockwellautomation.com/idc/groups/literature/documents/du/ra-du002_-en-e.pdf).

Rockwell Automation maintains current product environmental information on its website at <http://www.rockwellautomation.com/rockwellautomation/about-us/sustainability-ethics/product-environmental-compliance.page>.

Allen-Bradley, CENTERLINE, Rockwell Automation, and Rockwell Software are trademarks of Rockwell Automation, Inc. Trademarks not belonging to Rockwell Automation are property of their respective companies.

Rockwell Otomasyon Ticaret A.Ş., Kar Plaza İş Merkezi E Blok Kat:6 34752 İçerenköy, İstanbul, Tel: +90 (216) 5698400

**[www.rockwellautomation.com](http://www.rockwellautomation.com)**

### Power, Control and Information Solutions Headquarters

Americas: Rockwell Automation, 1201 South Second Street, Milwaukee, WI 53204-2496 USA, Tel: (1) 414.382.2000, Fax: (1) 414.382.4444  
Europe/Middle East/Africa: Rockwell Automation NV, Pegasus Park, De Kleetlaan 12a, 1831 Diegem, Belgium, Tel: (32) 2 663 0600, Fax: (32) 2 663 0640  
Asia Pacific: Rockwell Automation, Level 14, Core F, Cyberport 3, 100 Cyberport Road, Hong Kong, Tel: (852) 2887 4788, Fax: (852) 2508 1846

Publication 2100-IN010E-EN-P - November 2018

Supersedes Publication 2100-IN010D-EN-P - February 2007

PN-522964

Copyright © 2018 Rockwell Automation, Inc. All rights reserved. Printed in the U.S.A.