

®

80%

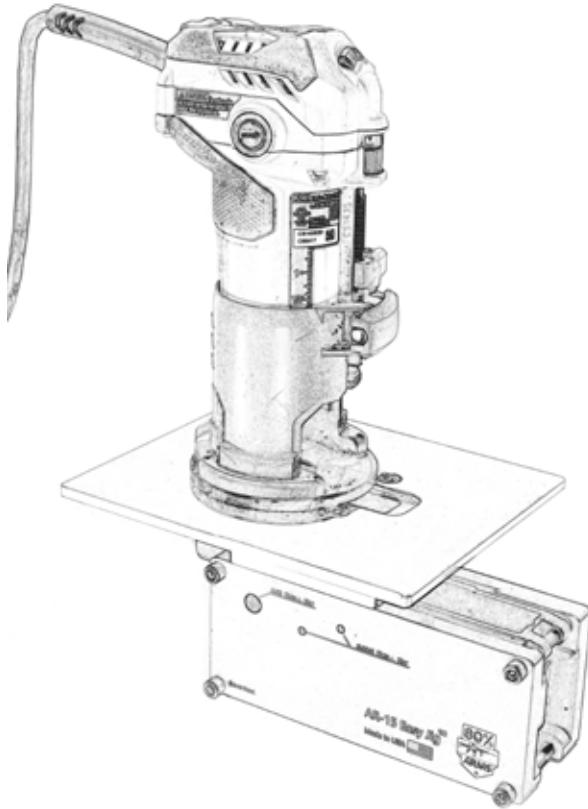

ARMS



AR-15 EASY JIG® MANUAL

WARNINGS AND SAFETY NOTICE

READ ALL INSTRUCTIONS AND WARNINGS BEFORE USING THE PRODUCT. DO NOT USE THIS PRODUCT IF YOU DO NOT UNDERSTAND THE INSTRUCTIONS AND WARNINGS. FAILURE TO READ THESE INSTRUCTIONS AND TO FOLLOW THESE WARNINGS MAY RESULT IN SERIOUS INJURY OR DEATH TO YOU AND OTHERS AND DAMAGE TO PROPERTY.

This manual should always accompany your jig and be transferred with it upon change of ownership. A copy of the manual can be downloaded for free from <http://www.80PercentArms.com/pages/manuals> or by contacting 80 Percent Arms.

Using this product on an 80% lower will convert the 80% lower into a firearm. Even if the 80% lower is not fully milled or completed, it may still be legally considered a firearm. It is your responsibility to comply with all federal, state and local laws and regulations regarding the ownership, possession, and transportation of a firearm. Certain configurations of the lower created by the end-user with an upper, may subject the firearm to classification under the National Firearms Act, which imposes registration, taxes, and other requirements on the owners of such firearms.

Working with power tools and cutting metal is inherently dangerous. Follow all safety instructions provided by the power tool's manufacturer. By using this product you agree that you are aware of these risks, and agree not to hold 80 Percent Arms liable for any injuries or property damage that may occur through the use of our product. Proceed at your own risk.

80 Percent Arms warns all users of our products to exercise extreme caution in the handling of any firearm. Because any firearm is potentially dangerous, the user should successfully complete a recognized firearms safety course before handling or employing any firearm. Before attaching your finished lower receiver to an upper receiver, ensure that the safety and trigger mechanisms are functioning properly. This must be done BEFORE the lower receiver is attached an upper receiver or made capable of firing. If you are not an experienced gunsmith, we recommend taking your completed lower receiver to a licensed gunsmith who can ensure that it is functioning properly, and that the safety is in good working order. Remember that you are the most important safety device when it comes to the safe handling of your firearms. By using our product you further agree that 80 Percent Arms will not be held liable for any personal injury, death or property damage that results from the use of any firearm created with our products. If you do not agree to these terms, please do not use this product, and contact us to return your unused product for a refund.

Under no circumstances shall 80 Percent Arms be responsible for incidental or consequential damages with respect to economic loss, injury, death or property damage, whether as a result of breach of warranty, negligence or other-wise. Some States do not allow the exclusion or limitation of incidental or consequential damages, so the above limitation or exclusion may not apply to you.

MESSAGE FROM 80 PERCENT ARMS

Thank you for purchasing our 80 Percent Arms Easy Jig®. Our patented router based milling system is the fastest, easiest, and most popular method to mill your 80% lower at home using common household tools. Our jig's heavy duty construction ensures your jig will last a very long time and allow you to complete many lowers before needing any replacement parts.

For best results, we strongly recommend that you read this manual from start to finish before getting started with your build. It's very important that you are familiar with all the steps you will need to perform to minimize the chance of making a mistake. If you have any questions after reading the manual, please contact us for assistance. We highly recommend watching our video tutorial prior to milling your lower. Additional resources including video tutorials and online manuals are available at our web site at: www.80PercentArms.com/pages/manuals

IMPORTANT SAFETY NOTICE

Eye and hearing protection must be worn at all times when operating any of the power tools required to finish your 80% lower. You must wear impact resistant safety goggles at all times to protect your eyes from flying debris and chips while drilling and milling. Do not wear open style safety glasses as they do not provide protection from flying chips. **Never use compressed air to blow or clear metal chips.** Instead, use a Shop-Vac to suck out chips from your jig and work area.

ROUTER INFORMATION

Most good quality small laminate routers with a 1/4" collet can be used with the Easy Jig®. They may be fixed or variable speed. Full size routers may also be used along with a spacer to provide clearance for the buffer tube when milling the trigger slot; however, we recommend using a smaller laminate router for best results. Recommended routers include the Home Depot Ridgid #R24012, Porter-Cable PCE6430, and Dewalt DWP611. Economy routers such as Harbor Freight and Black & Decker brands should be avoided.

For best results, set you router speed to 24,000 - 30,000 RPM. Cutting fluid is recommended to prolong the end mill and drill bit life, and to achieve a smoother finish. Keep the flutes and shank of the end mill lubricated at all times. Clear out chips after each pass for longer tool life and a smoother finish.

INCLUDED PARTS ILLUSTRATION

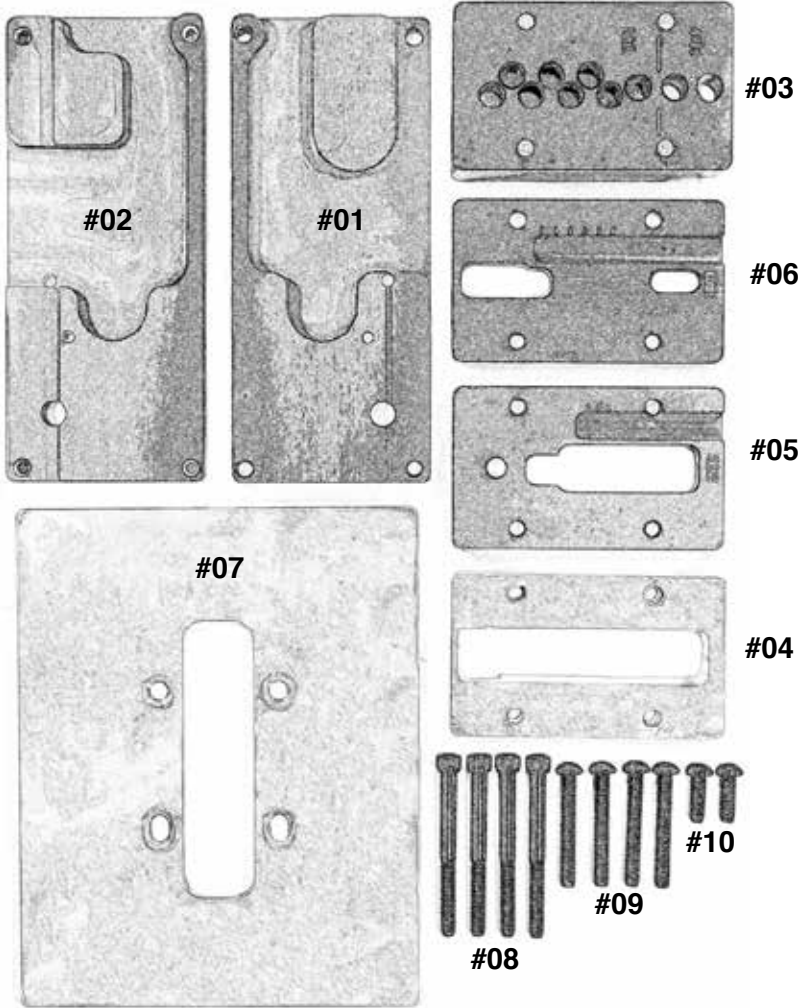

PURCHASED SEPARATELY EASY JIG® TOOL KIT



INCLUDED PARTS

- #01: Right Jig Wall (1pc)
- #02: Left Jig Wall (1pc)
- #03: Pocket Drilling Block (1pc)
- #04: Template Spacer (1pc)
- #05: Trigger Pocket Template (1pc)
- #06: Rear-Shelf Pocket Template (1pc)
- #07: Router Base Support Plate (1pc)

Included Bolt Set

- #08: Jig Wall Bolts 2.5" (4 pcs)
- #09: Template Bolts 1.75" (4 pcs)
- #10: Trigger Milling Bolts 0.75" (2 pcs)

REQUIRED TOOLS

- Router (w/ 1/4" collett)
- Drill (Hand or Drill Press)
- Table Vise or 2 Table Clamps
- 1/8" Allen Wrench (for template bolts)
- 3/16" Allen Wrench (for jig bolts)
- 3/32" Allen Wrench (for stop collar on drill bit)
- Cutting fluid such as Tap Magic, Relton A9, Oatey Dark Cutting Oil mineral oil, or motor oil.
- Masking tape
- Eye and hearing protection

END MILL CAUTION NOTICE

The drill bits and other tools required to use the Easy Jig® are available at most local hardware stores, or you may already have them at home; however, the required 1/4" end mill is custom made for 80 Percent Arms with very short flutes to work with the Easy Jig®. **Using any other type of end mill may cause permanent damage to your jig which is not covered by the warranty.**

You can purchase just the 1/4" end mill, or a complete tool kit with all the drill bits and the end mill, from 80 Percent Arms or from the store where you purchased your Easy Jig®.

PURCHASE SEPARATELY

Easy Jig® Tool Kit Includes:

- #11. 1/4" x 4" long 3-flute Solid Carbide End Mill with 0.75" flute cut length
- #12. 3/8" drill stop collar
- #13. 3/8" drill bit
- #14. 5/32" Jobber Length Drill Bit
- #15: 19/64" Jobber Length Drill Bit

DRILL BIT ADVICE

Use sharp high quality drill bits designed for drilling aluminum, such as those sold with our Easy Jig® Tool Kit. Using dull or low quality drill bits will make drilling very slow and difficult. This is very important when drilling through the harder 7075 aluminum lowers.

STEP 1

Attach side plates #01 and #02 to lower receiver using the Jig Wall Bolts #08. Tighten the (4) bolts in an alternating manner. **Do not over tighten bolts**, just snug with an Allen key. **Use masking tape or painter's tape to mask all areas of the receiver that will not be machined.** Do not place tape between mating surfaces.

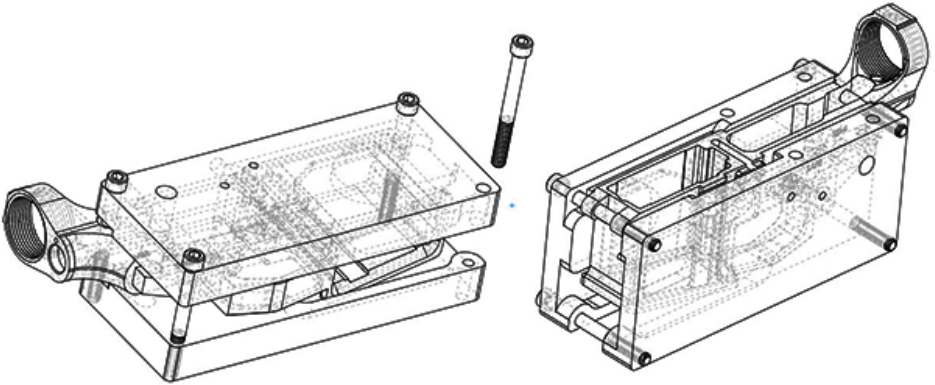

STEP 2

Attach the pocket Drill Block #03 to the top of the jig using the #09 Bolts. Alternate tightening the top bolts to ensure you have your jig walls parallel and spaced apart correctly. **Use a piece of tape to cover up the two rear pocket holes** located on the "REAR" side of the pocket drilling template #03.

WARNING: The last two holes reside above the rear pocket which sits higher than the rest of the pocket—**do not drill out these holes yet.**

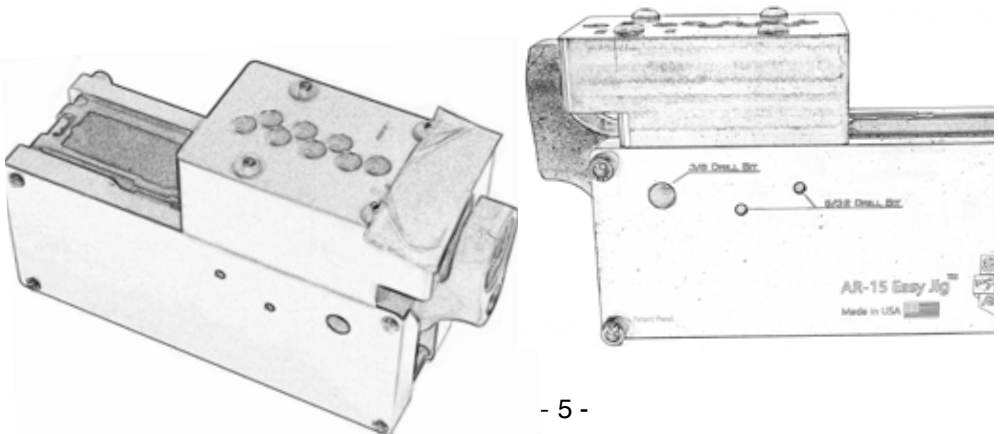

STEP 3

Prepare the 3/8" Drill #13 and 3/8" Drill Stop #12 to the appropriate length by using the Rear Shelf Pocket Template #06 labeled **MAIN**. Securely tighten the drill stop collar. The drill bit should be touching the bottom of the depth gauge. Before drilling out the 8 holes, secure the jig assembly in your vise.

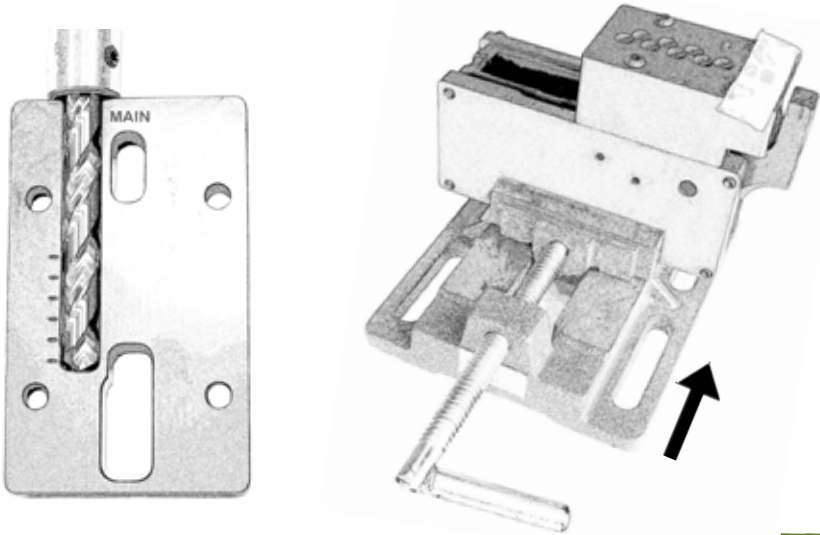

STEP 4

Drill out the 8 holes checking the drill bit length using the template depth gauge after each hole. If you're using a hand drill, make sure you drill straight down—do not lean at any angle. **TIP:** Slow down and reduce the pressure when your **Drill Collar** gets close to touching the **Drill Block**. Avoid allowing the stop collar to touch the drill block in order to prevent the drill stop collar from sliding and over-drilling the hole. We suggest using cutting fluid while drilling and a shop-vac to periodically clear out the chips as you drill.

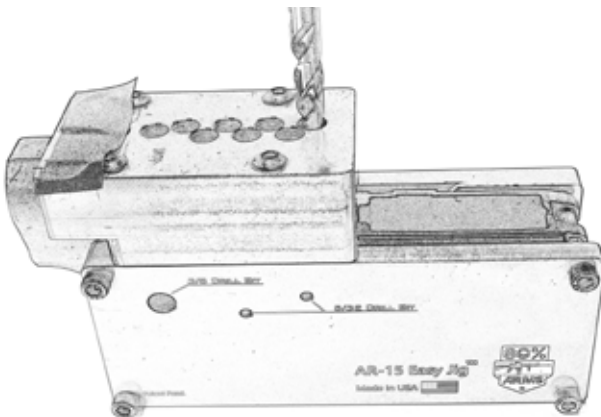

STEP 5

Drill the two rear holes for the rear shelf. (**NOTE:** If your lower already has the rear shelf lug area milled out, skip step 5 completely and go to step 6.) **Remove the top rear jig bolt so you do not drill through it.** Remove the tape to expose the REAR drill block holes. Prepare the 3/8" Drill #13 and 3/8" Drill Stop #12 to the appropriate length by using the **Trigger Pocket Template #05** labeled REAR. Removing the rear Jig bolt can cause the lower to slip downward if the vise is not tight enough. Re-insert the bolt into the left jig wall and thread in only 7/8" of the tip of the bolt into the left jig wall. The tip of the bolt will go partially into the the edge of the lower to keep the lower from slipping, but not so far as to get in the way of the bit. Drill out the 2 remaining rear shelf holes. When you're done, remove the **Pocket Drilling Block #03** and use a shop-vac to clean the jig and lower of chips.

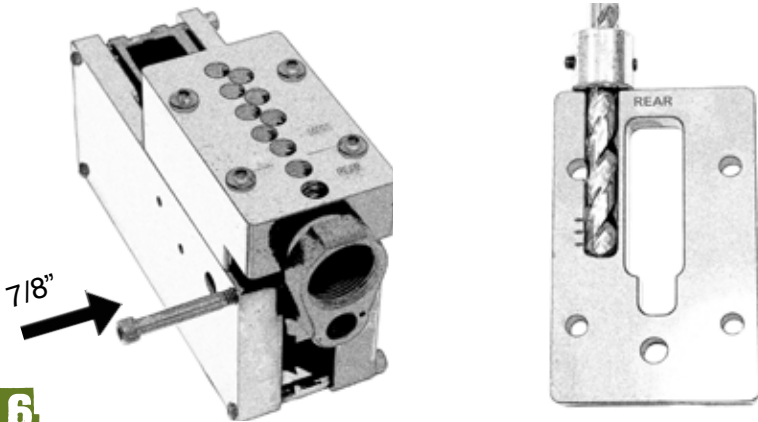

STEP 6

Prepare to mill the trigger pocket by placing the **Template Spacer #04** with the notched end towards the receiver extension hole (buffer tube hole). Then **stack the Trigger Pocket Template #05** so that the smaller end and the hole on the template is toward the buffer tube hole, and the raised lip on the template is facing up.

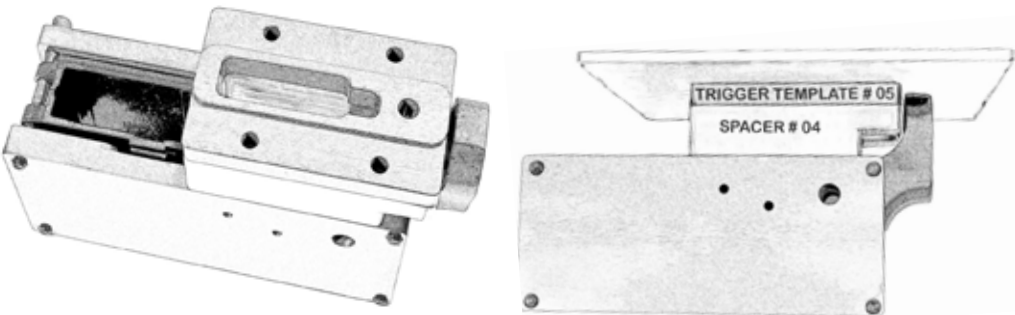

STEP 7

Place the Router Base Support Plate #07 over the lip of the template with the recessed bolt holes facing up. The router base only fits flush one way, so if your holes don't line up, rotate the support plate 180 degrees. Attach the plate using the #09 Template Bolts, tightening the bolts to the top of the jig walls in the same alternating fashion. Secure the assembled jig in the vise with the buffer tube hole closest to you.

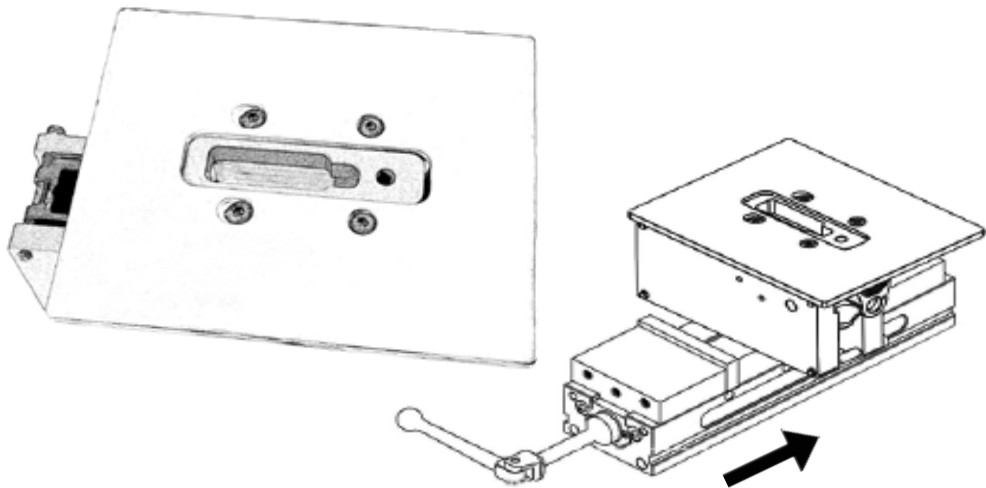

STEP 8

Install the 1/4" End Mill #11 into your router making sure the end mill is very tightly secured in the collet to prevent it from creeping out while milling. Adjust the cutting depth by using the depth gauge on the Rear Shelf Pocket Template #06 labeled **MAIN**. Adjust the depth of the router so the tip of the end mill is just below the first hash mark on the template. Re-insert and tighten the top rear Jig Bolt #08 through the lower if it was previously removed or loosened during step #5.

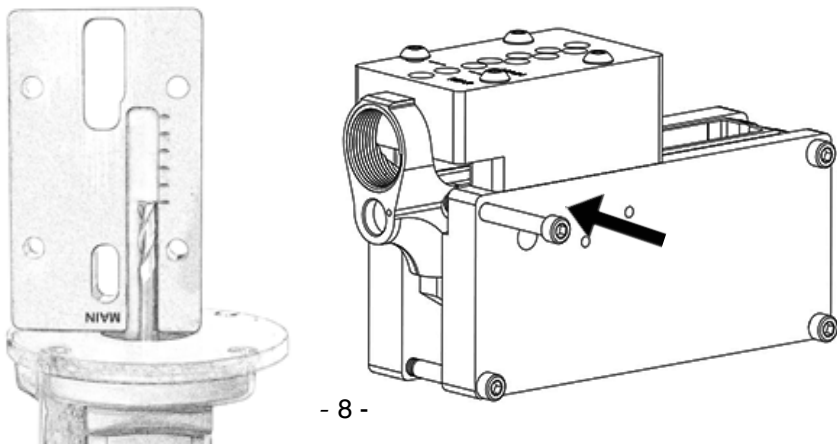

STEP 9

With the router off, insert the end-mill into the center of the furthest hole from you. The tip of the end-mill should be just below the top of the 3/8" hole you drilled out earlier. Maintain a firm grip on the router when turning it on. For your first cutting pass, only focus on removing material between the holes using a zig-zag pattern until all the holes are connected. Do not change the depth of the end-mill yet.

WARNING: Always turn off the router and wait for it to completely stop rotating before removing or inserting it into the jig or lower. Failure to do so may damage your lower and jig.

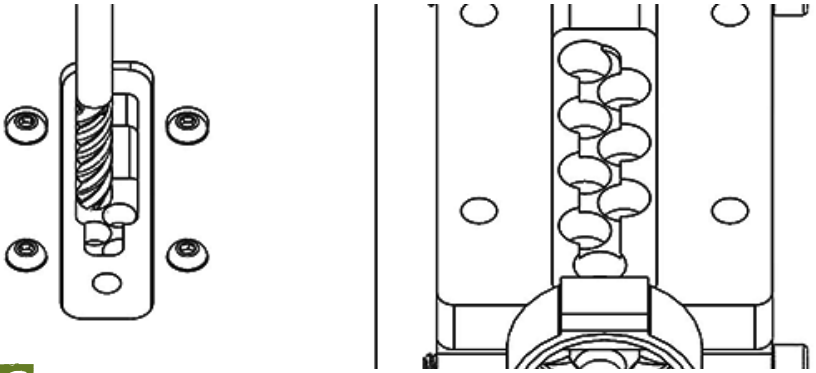

STEP 10

Once all of the holes are connected you can begin milling out the rest of the area. Start from the middle and work outwards in a clockwise direction. Keep doing this until the end mill shank is riding against the template. Once the first pass is complete, move the router to the middle of the pocket and turn it off before lifting it out of the jig. Wait until the end mill stops moving before lifting it out of the jig. Clear chips frequently with your Shop-Vac to avoid re-cutting chips. Keep the end mill lubricated when milling.

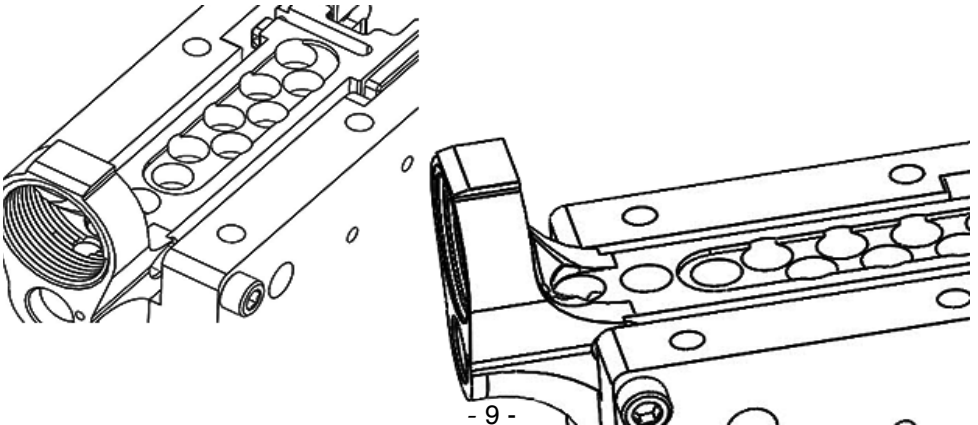

STEP 11

Continue taking deeper cuts by adjusting the end mill using the depth gauge on the Rear Shelf Pocket Template #06 labeled MAIN. For 6061 lowers increase the depth of the end mill incrementally 1/4 to 1/3 notch for each pass until you bottom out the end mill inside the depth gauge. **For 7075 lowers increase the depth by only 1/6 to 1/4 notch.** Each time, start inside one of the 3/8" holes and work from the middle out in a clockwise direction.

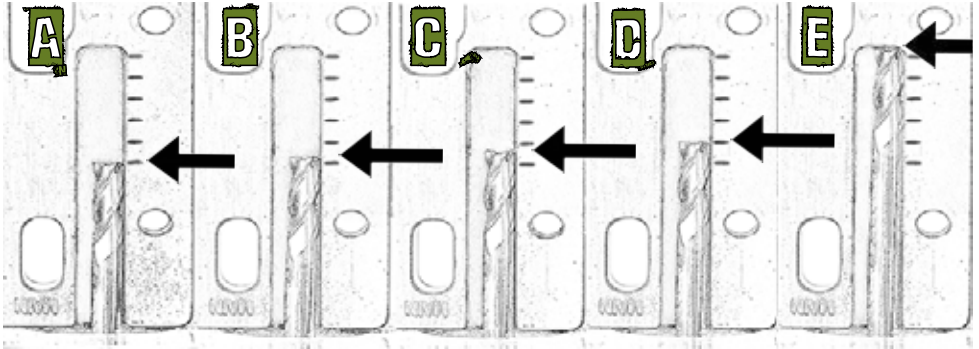

(Each image in A-D shows a 1/4 notch or hash mark incremental move. For the final pass, set depth to very top edge of gauge as shown in E.)

WARNING: On the last two passes before getting to the bottom, the end mill will not have a pre-drilled hole to start in. To prevent the end mill from jerking when powering up the router, hover the router slightly above the template and power up the router without the end mill touching the lower. Then, very slowly, lower the router while maintaining a firm grip on the router. For the final pass, the end mill depth is set so the end mill is past the last notch and touching the top of the depth gauge.

When this process is complete, you'll have the main trigger pocket milled out and two rear shelf holes drilled out.

TIP: Keep the jig and the lower clear of chips during the milling process for best results. Go slowly and adjust the depth back a 1/4 notch if necessary if you hear excessive noise or feel excessive chatter.

NOTE: If your lower came with the rear shelf area milled out, you do not need the two rear holes drilled as shown. **The front trigger pocket does not need to be connected to the rear shelf / lug pocket.**

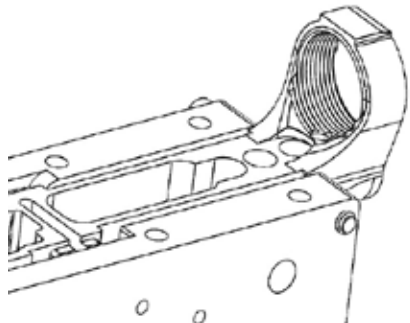

STEP 12:

Prepare the jig to mill the rear shelf.

TIP: If your lower already came with the rear shelf / lug area milled out, skip step 12 and 13 and move directly to step 14.

Remove the Router Base Support Plate #7 and the Trigger Pocket Template #5. Set the **Rear Shelf Template #6** on top of the **Template Spacer #4** so that the longer hole is closer to the buffer tube hole, and the raised lip of the template is facing up. Next, place the **Router Base Support Plate #7** over the lip of the template with the recessed bolt holes facing up. Attach the plate using the **Template Bolts #9**. Tighten the bolts to the jig walls in an alternating pattern. Secure the assembled jig in the vise with the buffer tube hole facing **away from you**.

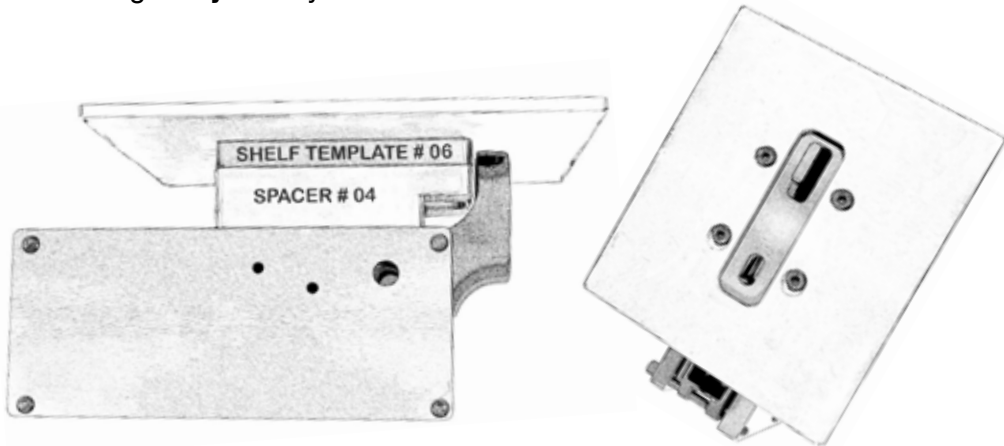

Next, pull out the top rear Jig Bolt #08 so you do not mill through it. Removing the jig bolt completely can cause the lower to slip downward if the vise is not tight enough. Re-insert and thread the tip of the bolt 7/8" through the **top left jig wall** threaded hole. The tip will go into the edge of the lower and keep the lower from slipping without getting in the way of the end mill.

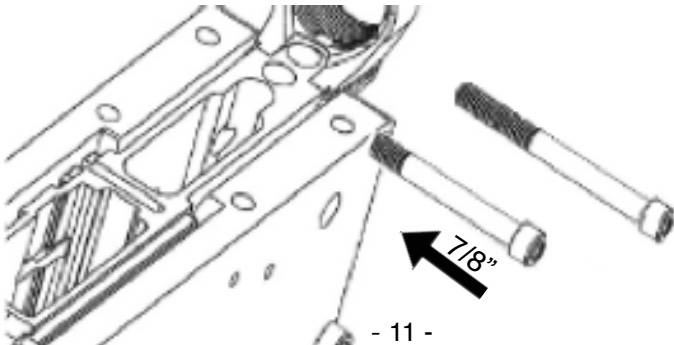

STEP 13:

Adjust the end-mill to the appropriate length to mill the rear shelf by using the depth gauge on the Trigger Pocket Template #05 labeled **REAR**.

Adjust your router depth so the end mill is touching the first notch / hash mark on the template depth gauge. Use the same milling process of connecting the holes and milling as outlined in Steps 9, 10 and 11.

WARNING: Do not mill out the smaller hole (trigger slot) of the Rear Shelf Template #6 during this step. If you removed or loosened the top rear Jig Bolt in step 12, be sure to reinsert and tighten the jig bolt before moving to the next step.

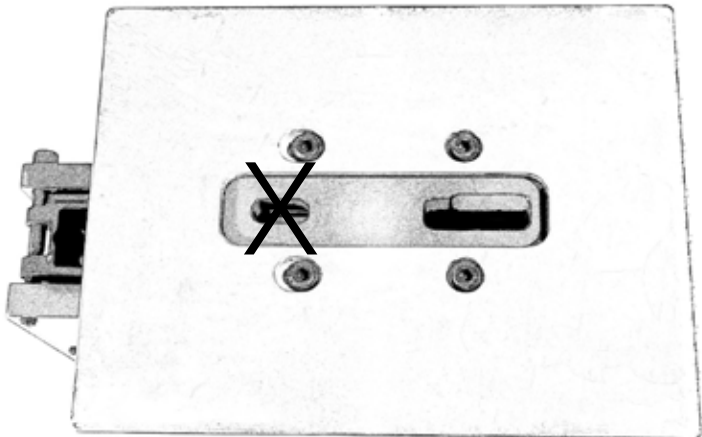
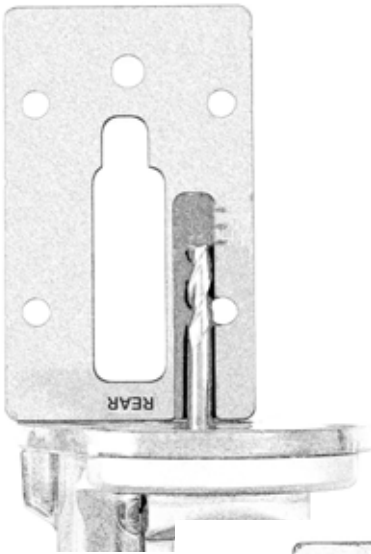

STEP 14

To complete the trigger slot remove all the top plates and the template spacer. Clear away chips from the lower and side plates. Reinsert and tighten the **Rear Jig Bolt #08**. Place the **Trigger Pocket Template #05** on the jig with the depth gauge facing down. Attach the **Trigger Pocket Template #5** to the jig side plates, inserting only the 2 short **Trigger Milling Bolts #10** into the two holes on the template closest to the buffer tub. Use the two jig wall screw holes furthest away from the buffer tube to secure the template.

Secure the Jig into the vise. **Using the 19/64" drill #15, slowly** drill the pilot hole.

WARNING: Use very little downward force when drilling the pilot hole. It is possible to drill past the bottom of the trigger area and into the trigger guard below if pressing too hard. Make sure to **go slowly** and control the downward pressure at all times.

TIP: If you are using a hand drill, it's important that you drill the pilot hole very straight. Do not drill at an angle or the pilot hole may drift outside the boundary of the trigger slot template. Use a punch, if available, to further prevent the drill bit from walking when you start drilling. **Use very little downward force and go slowly when drilling the pilot hole to prevent the drill bit from walking.**

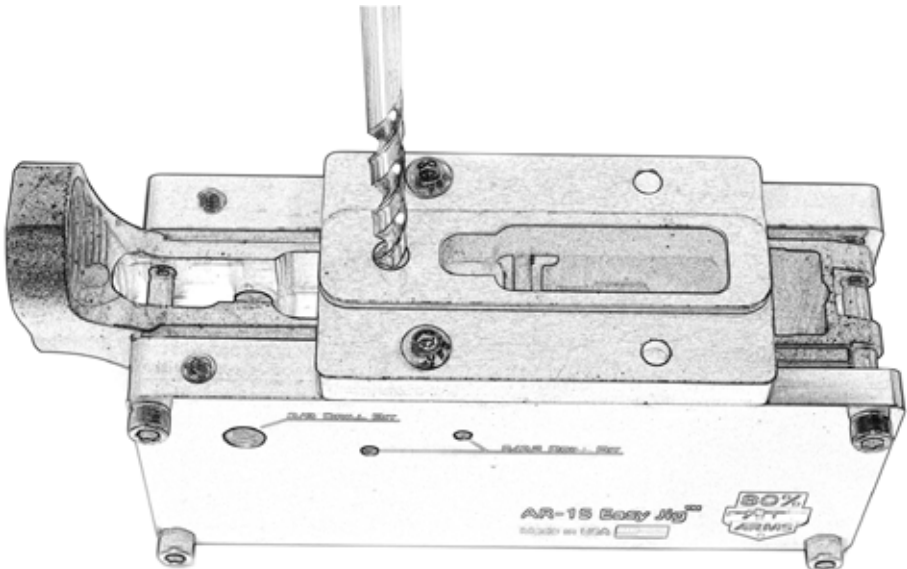

STEP 15:

To mill the trigger slot, remove the Trigger Pocket Template #05 and set the Rear Shelf Pocket Template #06 on the jig, with the raised lip facing up. Secure the Router Base Support Plate #07 on top of the template using only the 2 short Trigger Milling Bolts #10. Only use 2 bolts to attach the template and base plate. Insert the screws into the 2 holes on the base plate closest to the buffer tube, using the 2 screw holes on the jig side plates furthest from the buffer tube. The smaller trigger slot should be located closest to the buffer tube. **The larger slot over the magazine well is not used. Adjust the router depth setting so the end mill is slightly inside the drilled out trigger slot pilot hole.** With the end mill centered in the hole, turn on the router while keeping a firm grip on the router. Mill back and forth in a clockwise motion. Turn off the router and increase the depth by 1/6 to 1/4 notch and repeat the process. Continue until the trigger slot is fully milled out.

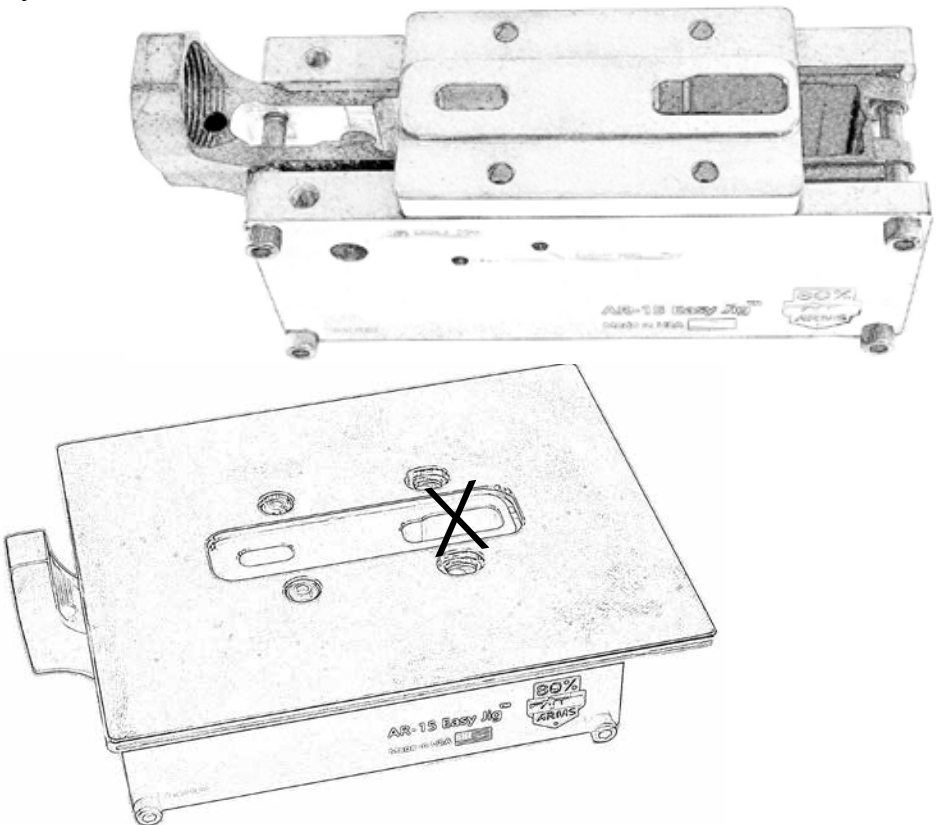

TIP: Only if using a full sized router with a large base, insert the Template Spacer #04 between the Pocket Template #06 and the jig wall, and use 2 of the longer 1.75" Template Bolts #9 instead of the short Trigger Milling Bolts. This will elevate the Router Support plate to allow a larger router base to clear the buffer tube.

STEP 16

Remove all of the template top plates to drill the trigger, hammer and safety selector holes. Clear out chips and reposition the jig and lower on its side. Because the bolts holding the jig together may stick out of the jig side plates, use spacers (such as the template plates) to raise the jig assembly so that it is laying level. Secure the jig on its side with a vice or clamp.

WARNING: If using a hand drill, make sure you drill straight down. Do not lean at any angle.

Insert the 5/32" Drill #14 into your drill press or hand drill and drill out the trigger and hammer pin holes on the right side. Next, install the 3/8" Drill #13 and drill out the safety selector hole on the right side. Flip the jig over and do the same for the left side. **Do not drill all the way through from one plate to the other.** Measuring from the top surface of the jig side plate, do not drill deeper than 1.25" to prevent drilling into the opposite wall of the lower.

WARNING: To ensure proper function, use a paperclip to clear out any chips from the safety selector detent hole. It's common to have chips stuck in the selector detent hole which will interfere with the function of the safety selector. These chips are not always easy to see. It's a good idea to push a paper clip though the safety selector detent hole even if you don't see any chips in there to clear out any hidden chips.

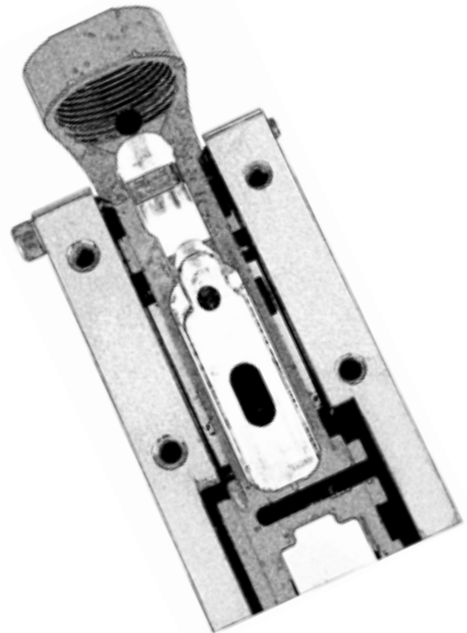
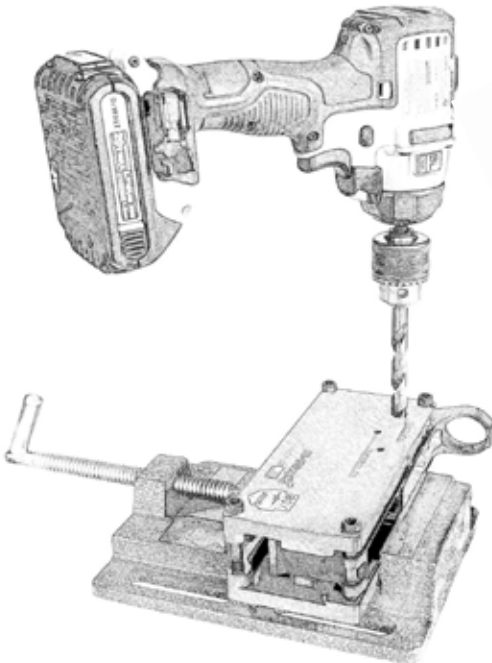

CLEAN UP TIPS

During milling, it's possible for small chips to rub between the jig plates and the lower. Aluminum residue from the chips can rub onto the anodized finish of the lower. The anodized finish on the lower is much harder than the raw aluminum chips. You can use a sponge with a mildly abrasive green Scotch Pad to remove marks left on the lower by the chips. Dip the sponge in soapy water and **gently** rub the lower to remove any marks.

If you milled a raw lower, **do not apply a finish coat to the lower until after you have installed your lower parts kit and performed a function test.** If you milled an anodized or Cerakoted lower, it is not necessary to apply a finish to the milled raw aluminum area.

SHOW OFF YOUR WORK

There's a great sense of satisfaction in building your own firearm. Join our community of builders on Facebook where you can display your work, see what others have done, and keep up with 80% news and new product announcements. Join us at www.facebook.com/80percentarms.

CONTACT US

Our dedicated support team is available by phone, email, and walk-in to answer your questions and for any service needs.

80 Percent Arms Inc.
3480 W Warner Ave., Suite N
Santa Ana, CA 92704

Phone sales and support: (949)-354-2767

Email support: support@80percentarms.com

LEGAL NOTICE

"Easy Jig" is a registered trademark or trademark of 80 Percent Arms Inc. The product covered by this manual is protected under copyright, patent, and other intellectual property rights. The router based Easy Jig® milling system is patented and is the exclusive intellectual property of 80 Percent Arms Inc. Unauthorized use of our router milling system, in whole or in part, is prohibited. Patent violations are strictly enforced. All images and content in this manual are copyright © 80 Percent Arms Inc. Unauthorized duplication or distribution of the contents of this manual without the prior written permission of 80 Percent Arms is prohibited. No part of this manual may be reproduced, stored in a retrieval system, or transmitted, in any form, or by any means, electronically, mechanically, by photocopying, or otherwise, without the prior written permission of 80 Percent Arms Inc.

PARTS AND ACCESSORIES

80 Percent Arms carries a complete line of replacement parts for the Easy Jig® and other parts and accessories to finish your build project, including matching 80 Percent Arms billet upper receivers. Visit us at www.80PercentArms.com to browse our full catalog of parts and accessories.

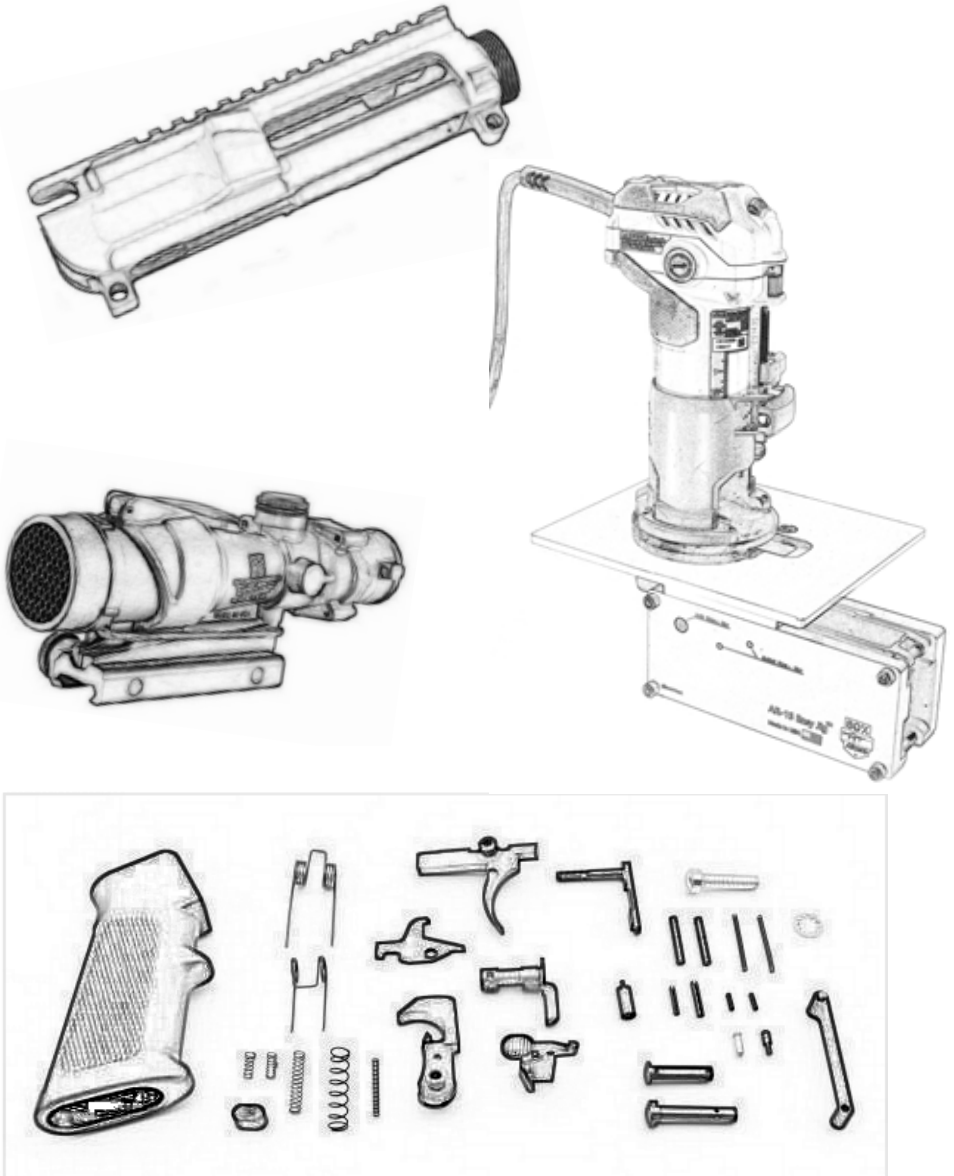

NOTES

**A WELL REGULATED MILITIA, BEING NECESSARY TO THE
SECURITY OF A FREE STATE, THE RIGHT OF THE PEOPLE TO
KEEP AND BEAR ARMS, SHALL NOT BE INFRINGED.**

