

Model Number:
Product Description:



SAFETY INSTRUCTIONS AND WARNING BOOKLET

 **WARNING**

National Standards, state and federal laws require the user to be trained before using this product. Use this manual as part of a user safety training program that is appropriate for the user's occupation. These instructions must be provided to users before use, and retained for ready reference by the user. The user must read, understand (or have explained) and heed all instructions, labels, markings and warnings supplied with this product and with those products intended for use in association with it.

FAILURE TO DO SO MAY RESULT IN SERIOUS INJURY OR DEATH.

MSA (Aust.) Pty. Limited
137 Gilba Road, Girraween NSW 2145 Australia

Australia Sales & Customer Service
Phone: 1300 728 672 Fax: (02) 9896 1835
Email: aus.customerservice@MSAnet.com

New Zealand Sales & Customer Service
Phone: 0800 441 335 Fax: 0800 441 329
Email: msanz@MSAnet.com

HARNESSES AND LANYARD ASSEMBLIES ARE CATEGORISED BY STANDARDS AS FOLLOWS:

FULL BODY HARNESSES

Fall Arrest Harness: A Fall Arrest Harness is to be used in conjunction with a lanyard assembly attached to a suitable anchorage point or static line, in situations where there is risk of a free fall.

Fall Arrest Harnesses contain a single assembly of interconnected shoulder and leg straps which may incorporate a body belt. Fall Arrest Harnesses are a single assembly and must not be separable into two or more parts without damaging the assembly and rendering all parts unusable.

Harnesses need to be capable of adjustment to fit the wearer. Shoulder straps shall be positioned such that undue pressure is not transmitted in the armpit region as a result of a person being suspended on sustaining a fall.

Confined Space Fall Arrest Harness: This harness is to be used for work in confined spaces wherever there is a risk of free fall, which could occur whilst travelling vertically.

Confined Space Fall Arrest Harnesses must include, in addition to criteria for a Fall Arrest Harness, the following:

- (a) Wrist straps which enable the wearer's arm or arms to be raised above the head to facilitate rescue and which shall be readily detachable from the wrist; and
- (b) Lifting attachment points fitted to the harness in a manner that will retain the wearer in a head-up position when being lifted.

LANYARD ASSEMBLIES

A Lanyard Assembly is to be used to connect a fall arrest harness, including a confined space fall arrest harness (if required) to a suitable anchorage point or static line to reduce forces associated in a fall to no greater than 6kN.

The assembly is made up of a lanyard, which may be in the form of synthetic fibre rope or webbing, or steel wire rope, and a personal energy absorber.

The lanyard assembly shall be as short as practicable and the working slack length is not more than 2.0m.

When estimating total, free fall distance and clearance distances required, the anchorage point and extension of the energy absorber needs to be taken into account. It is recommended that structural anchorage points for connection of equipment always be above the user of the equipment.

POLE STRAPS

A Pole Strap is to be used to support a worker on a pole by attachment to the 'D' rings located at the hips and identified as pole strap attachment points on a lineworker's harness. Pole straps are designed so that they constantly remain under tension once in the working position.

CONDITIONS OF USE

If this product is not used or stored correctly, or additions or alterations are made to them, the effectiveness of these devices may be considerably reduced.

WARNING

Alterations, additions or repairs not preformed by MSA (Aust) Pty Limited shall negate any warranty.

WARNING

This product must be immediately removed from service and either returned to the manufacturer or authorised manufacturers agent for inspection, if appropriate, or destroyed if a fall has been sustained.

Any item showing excessive wear or deterioration should be destroyed. Inspect all equipment before each use; failure to observe proper inspection and usage procedures could result in permanent injury or death.

TRAINING

This is the responsibility of the purchaser to ensure that product users are made familiar with these User Instructions and trained by a competent person. Training must be conducted without undue exposure of the trainee to hazards. The effectiveness of training should be periodically assessed (at least annually) and the need for more training or retraining determined. MSA offers training programs. Contact MSA for training information.

USER INSTRUCTIONS

WARNING

You must read and understand, or have the following instructions explained to you. Inspect equipment before using.

They must be adhered to:

1. Do not attempt to work at heights if you are feeling unwell or are susceptible to giddiness.
2. Before putting on, visually check Harness and Lanyard Assembly for defects.
3. Follow donning instructions. Be aware that if your connection point to the harness cannot be visually seen by the wearer then it should be attached prior to donning harness or checked for security by a second person.
4. Having reached your position select a suitable anchorage point, capable of withstanding at least 15kN of force without permanent distortion and in the event of a fall. The anchorage point should be as high as possible above you in a vertical plane to reduce the fall distance and the potential to pendulum should you fall. Consideration must also be given to the surrounding area – avoid using an anchorage point that would permit you to strike or swing into obstructions before a fall is safely stopped.

ANCHORAGE WARNING

Before making your connection to an anchorage point, always ensure that it is perfectly sound and structural of sustaining shock loads of at least 15kN without distortion in the event of a fall.

Pendulum (Swing) Falls: Swing falls can occur when the system is not anchored directly above the user. The force of striking an object in a pendular motion can cause serious injury. Always minimize swing falls by working as directly below the anchorage point as possible.

Swing fall hazards must be minimized by anchoring directly above the user's work space.

5. **NEVER MAKE YOUR ANCHORAGE CONNECTION BELOW THE LEVEL OF THE ATTACHMENT POINT ON YOUR HARNESS.**
6. In making your connections to the anchorage point always observe the following:
 - a) That the screw ferrule on a screwgate karabiner is fully screwed up into the locked position.
 - b) If using an automatic locking karabiner that the revolving ferrule has moved into the locked position.
 - c) The latch or gate on either double acting latch snap hooks or karabiners is in a locked and correct position.
7. Where a much larger working area is required from a single anchorage point than that permitted by the normal Lanyard Assembly then Fall Arrest Harness should be used in conjunction with either Retractable Cable Devices or Self-Locking Mobile Fall arrest Devices.
8. When using a Harness in conjunction with a Retractable Cable Device or Inertia Reel Lifeline Block, connect it to a Fall Arrest attachment point via the Swivel Hook at the free end of the Cable. This also ensures that the Cable does not get in your way whilst you are working.

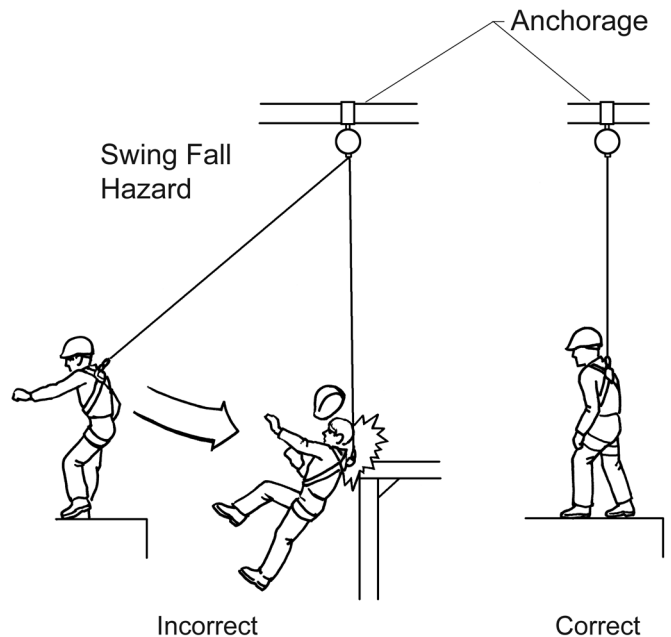

9. For attaching a Self-Locking Mobile Fall Arrest Device use as a minimum a double action snap hook or karabiner to make the connection via the rear 'D' ring, or alternatively, the frontal Fall Arrest attachment point. At no time must the connector between the harness and device exceed 300mm.
10. The following methods must not be used to make your connection to the anchorage point.
- Do not tie off over sharp edges or snap hook onto the lanyard. See drawing A.
 - Do not tie off where Hook latch will not fully close. See drawing B.
 - Do not knot lanyard in any manner. Avoid sharp edges. See drawing C

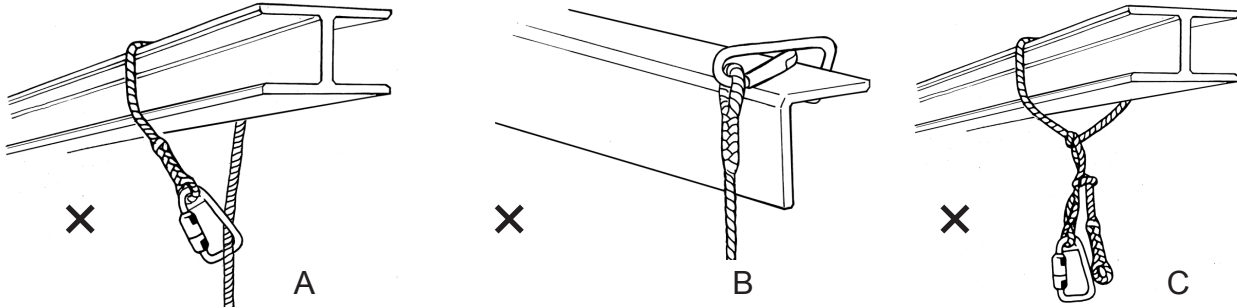

11. Drawings D, E and F illustrate the correct method to follow in making your connection to a structural anchor point when the gate opening of your safety hook is of insufficient size to allow direct connect around the structure.

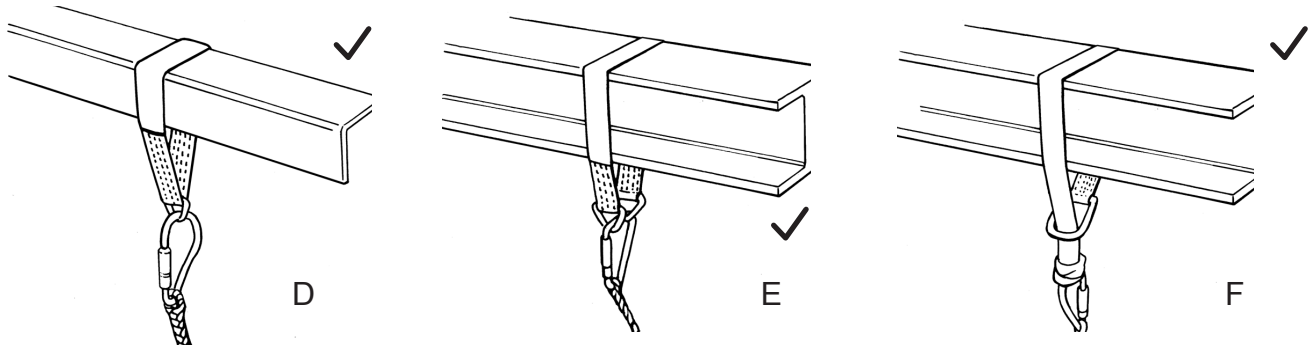

12. When using a Harness in conjunction with a self adjusting Pole Strap (for work on poles or structures where the harness is continuously loaded) it should be noted that they are not intended for situations permitting a drop of more than 600mm.

At working position, pass Pole Strap around pole and connect back to harness by connecting Snap Hooks at end of Pole Strap to the harness side 'D' rings.

To adjust to a comfortable working position use adjuster to either slacken off or draw up on the Pole Strap.

13. CONFINED SPACE FALL ARREST HARNESSSES

Confined Space Fall Arrest Harnesses are intended for use by persons working in confined spaces where there is a risk, however slight, of potential free fall and or being overcome by gases, fumes or vapours. Confined Space Fall Arrest Harnesses come complete with a Spreader Bar as a system of safety. The Spreader Bar is attached via the snap hooks to the nominated and labelled Retrieval attachment points on the shoulder straps of the harness.

The anchorage (rescue line) attaches to the 'D' ring on the spreader bar.

When work is required to be carried out in vats, tanks, sewers or other confined spaces, before entry is made pre-entry checks for gases, fumes, or explosive vapours and equipment requirements should be carried out. Confined Space Fall Arrest Harnesses are also intended for workers in coal bunkers, slack hoppers, grain silos and the like where there is the danger of suffocating by engulfment in the material on which they are standing.

CHEMICAL ATTACK WARNING

If any part of an assembly is to be exposed to chemicals, e.g. cleaning materials or hazardous atmospheres, consult the manufacturer to determine whether the part is suitable for continued use.

14. LANYARD ASSEMBLIES

Lanyard Assemblies are intended for use by persons that are exposed to potential free fall.

The working slack length on Lanyard assemblies must never exceed 2.0m.

Always ensure there is adequate clearance below, such that if a fall occurs, striking of obstacles never exists.

Lanyard Assemblies and Personal Energy Absorbers are designed to reduce shock loads in Fall Arrest situations. The Personal Energy Absorber will extend in length due to webbing or stitching tearing and will permanently deform once subject to impact loads, as would be the case in arresting a fall. Should any sign of deformation or webbing tear out from the Personal Energy Absorber occur the device shall be immediately removed from service and marked as 'UNUSABLE' until destroyed.

WARNING

If the Shock Absorbing Lanyard has been subjected to fall arrest, impact forces, shows signs of deformation or webbing tear out it must be immediately removed from service and marked as 'UNUSABLE' until destroyed.

DIAMOND SHOCK ABSORBING LANYARD WARNING

If the red 'REMOVE FROM SERVICE' label has been exposed, immediately remove from service and mark as un-usable until destroyed.

The Workman Shock Absorbing Twin Lanyard range is supplied with a velcro attach Lanyard Stowage Point, (Part No. 766276). The Lanyard Stowage Point attaches to either the left or right shoulder strap of the users harness and is the only place on the harness that the unanchored lanyard tail shall be stowed when not in use.

TWIN-TAIL LANYARDS WARNING

Do not under any circumstance attach the free Lanyard tail to any other part of the harness other than the Lanyard Stowage Point. Back-hooking of the free tail to any point on the wearer, the wearer's equipment or the lanyard below the bifurcation other than the Lanyard Stowage Point is prohibited.

Be aware that when securing a harness via a lanyard to an anchorage point, the connection should be at a level which will result in the minimum free-fall and the least total fall distance consistent with the wearer's ability to carry out work tasks.

Consideration needs to be given to the following when using Lanyard Assemblies

1. Free fall distance.
2. Total fall distance. The sum of the free fall distance and deceleration distance.
3. Total and Free fall distance including extension of personal energy absorber.

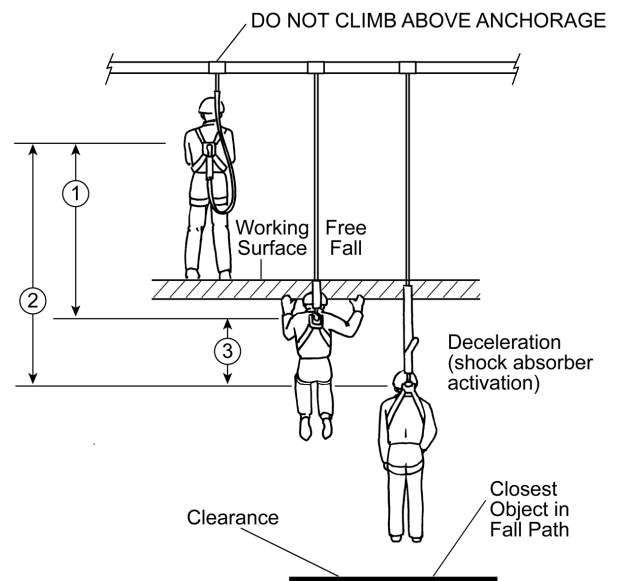

INSPECTION OF HARNESSES AND LANYARD ASSEMBLIES

All MSA Harnesses and Lanyard Assemblies are made to comply with the exacting strength requirement of AS/NZS 1891:1 and only the highest quality materials are used in manufacture, whilst the whole process of manufacture is conducted under an ISO 9001 Quality System.

To ensure these products are maintained in safe working order, the following procedures must be adhered to.

Thoroughly inspect each item of equipment before and after each use for wear, deterioration or damage. As per AS/NZS 1891.4, the equipment shall be examined by a competent person, other than the user, and a record kept of this examination on an appropriate Inspection Record Card. See Inspection / Record Card at rear of this manual.

Equipment found to be damaged or suspect shall not be returned to service until the necessary repairs have been effected, if such can be carried out.

WHAT TO LOOK FOR WHEN INSPECTING MAN-MADE FIBRE WEBBINGS

The following information details the principal causes of deterioration in man-made fibre webbings and indicates the signs by which they can be recognised.

GENERAL SURFACE ABRASION

This occurs due to contact with abrasive surfaces and is easily recognisable as the webbing fluffs up along the surface. This often occurs in normal use and is harmless if not too extensive. Man-made fibre webbings have very good abrasion resistance.

ABRASION

Usually caused as a result of the webbing being passed over a sharp edge whilst under tension. Any reduction in the width and thickness or severe damage to the weave pattern shall be cause for rejection. Slight surface damage and the occasional torn yarn may be considered acceptable.

CUTS, NICKS, BURNS ETC.

These, if found anywhere on a Harness or Lanyard Assembly, are to be considered as potentially dangerous and must lead to immediate tagging out of service and destruction of equipment.

CHEMICAL ATTACK

Usually indicated by discolouration and local weakening or softening of the webbing. The surface fibres, in extreme circumstances, can be rubbed off as a powder. If found, tag out of service and destroy.

HEAT

Webbings affected by heat become brown and brittle and in extreme cases, break when flexed. If found, tag out of service and destroy.

INSPECTION OF WEBBINGS SHOULD BE CARRIED OUT AS FOLLOWS

Lay out product on work bench – major damage or wear will immediately be apparent. For detailed inspection, take a section of the webbing and form an arch of approximately 100mm between your hands. With the outside of the webbing being raised, the resulting surface tension will highlight any broken fibres, stitches, cuts, etc. Pass the webbing through your hands until the whole of the product has been visually inspected, It is a good idea to mark off the separate straps with chalk to indicate those inspected and to avoid the possibility of missing one out.

INSPECTION OF MAN-MADE FIBRE ROPES

The following information details the principal causes of deterioration in man-made fibre ropes and indicates the signs by which they can be recognised.

ABRASION WARNING

Attachment lines, Lanyards etc., can be damaged and weakened by contact with sharp edges or abrasive surfaces. Always exercise care when working in situations where ropes could be maltreated.

EXTERNAL WEAR

Usually follows from the rope being dragged over rough surfaces and results in a general reduction of the cross section of the strands. In extreme cases, the strands become so worn that the yarns are severed on the outer side. In normal use, minor disarrangement or breakage of the outer fibres along the length of the rope is unavoidable; provided it is not too extensive, this may be considered acceptable.

ABRASION

Generally arises as a result of the rope being passed over a sharp edge whilst under tension. Usually damage manifests itself as broken fibres, yarns or strands. Any significant damage should be cause for the rope to be tagged out of service and destroyed.

HOCKLING

Generally indicated by unravelling of the strands of rope. Usually caused by anchoring the loose end of the rope and/or frequent turning by the user in a direction opposite the natural lay of the rope. The end user should inspect the rope before and after each use to see if there are any indications of hockling. If so, the user should twist the rope in the direction of manufactured twist to work the loops back into the natural lay of the rope.

CUTS, NICKS, ETC .

Ropes found to have cuts, nicks, etc., are to be considered as potentially dangerous and are to be taken out of service immediately and destroyed.

CHEMICAL ATTACK

Usually indicated by a change in colour and local weakening or softening of the section affected so that surface fibres can be rubbed off as powder in extreme cases. If contamination is suspected, the rope must be taken out of service and destroyed.

HEAT

The following are signs that a rope has been subjected to extreme heat – charring, singeing or fusing of the fibres. If any of these are apparent, the rope must be tagged out of service and destroyed.

INTER-STRAND WEAR

This occurs following repeated flexing of the rope, more so if wet, and by the ingress of particles of grit. Displays itself by looseness of the strands and the presence of powdered fibre. In extreme cases, the rope must be tagged out of service and destroyed.

SUNLIGHT DAMAGE

If belts and harnesses are exposed to intense sunlight they will be affected by ultra violet light. This is detectable by a pronounced fading of the dye colour. In extreme cases items affected must be taken out of service and destroyed.

OVERLOADING

Ropes which have been subjected to heavy loads display the following characteristics; reduction in rope diameter, or, after severe loading, the rope will be unusually rigid. A sure indication that the rope has been overloaded is to check the splice – if it is pulled tight and the thimble is excessively loose, then overloading has most probably occurred in which case, the rope should be tagged out of service and destroyed.

Inspection of ropes for the foregoing causes of deterioration should be carried out as follows:

1. Lay out Lanyard Assembly along workbench.
2. Start at one end, working along to the opposite end, rotate the Lanyard Assembly slowly, checking the circumference for defects.
3. Check that splices are sound and that ends are protected with a rubber or plastic sleeve.
4. Ensure thimbles are correctly seated and a tight fit.

WHAT TO LOOK FOR WHEN INSPECTING A HARNESS.

INSPECT WEBBING AS ADVISED

Inspect all machine sewings for broken stitches or worn threads – special attention should be given to the sewings which retain load bearing components, e.g. hooks, 'D' rings, buckles, etc.

Inspect all labels ensuring that they are perfectly legible and adequately secured.

Inspect all metal components

Buckles – check for distortion, sharp edges, burrs, cracks or worn parts. If applicable, ensure moving parts function satisfactorily.

'D' Rings – check for distortion, sharp edges, burrs, cracks or worn parts.

Snap Hooks – check snap action, ensuring the return spring is functioning correctly and that there is no sideways play on the latch in the closed position. Check for distortion, sharp edges, burrs, cracks or worn parts.

Automatic Locking Hooks and Karabiners - check that the trigger opens fully and that it returns itself and automatically revolves the ferrule into the locked position. Check for distortion, sharp edges, burrs, cracks or worn parts. The automatic locking action can become impaired by the ingress of sand, boiler dust, etc. Cleanse by soaking in paraffin. If the automatic locking action is clogged with mud soak in hot water to restore action to normal.

Screwgate Karabiners – check snap action and that screw ferrule functions satisfactorily. Check for distortion, sharp edges, burrs, cracks or worn parts.

FOR PLATED COMPONENTS, CHECK FOR BREAKDOWN IN PROTECTION AND SIGNS OF CORROSION. ANY HARNESS, OR LANYARD ASSEMBLY WITH SUSPECTED FAULTS SHALL BE IMMEDIATELY WITHDRAWN FROM SERVICE AND, IF THE FAULT CANNOT BE RECTIFIED, MUST BE DESTROYED.

WHAT TO LOOK FOR WHEN INSPECTING A THERMATEK CROSSOVER WEBBING HARNESS

Inspection of the Thermatek Crossover Harness is as per any other harness in the MSA range with the following exceptions;

- The Kevlar (60%) and Nomex (40%) blended webbing of this harness is designed to absorb chemical spills, high heat, and weld spatter without affecting the structure staility of the harness.
- For weld spatter a small burn will typically occur in the green Nomex material. The burns will self-extinguish in a few seconds.
- Small holes concentrated in the green Nomex material will not affect the performance of the harness. Burn holes in the Nomex material that are larger 3.3mm in diameter, and no more than two such holes in a 19.0mm diameter radius will be acceptable for continued use. A burn hole must not be closer than 3.3mm to a webbing edge.
- When Inspecting the Thermatek Harness, pay particular attention to the yellow kevlar which is inside the Nomex, If the yellow kevlar is exposed and is discolored, then the harness should be tagged out of service and destroyed.

SERVICE

Remove from service and destroy all Harnesses, Pole Straps and Lanyard Assemblies that are 10 years old from the date of manufacture and destroy.

CLEANING

Harnesses and Lanyard Assemblies made from man-made fibres should be regularly cleaned. The frequency of cleaning depends upon the conditions in which they are being used but in any event, the period between cleanings should not exceed 3 months.

INSTRUCTIONS FOR CLEANING

First wipe off all surface dirt, mud, dust, etc., with a damp sponge. Rinse out the sponge then, using a mild solution of water and household detergent, thoroughly lather. Finish off by rinsing with clean water and wiping as dry as possible with a clean cloth.

To remove heavy deposits of grease or creosote, use a diluted solution of heavy-duty detergent cleaner and water. Work the diluted liquid into the webbing fabric with a brush. Rinse off with clean water and wipe as dry as possible with a clean cloth.

Following cleaning, the equipment should be left to dry thoroughly hanging freely in a position where it will not be exposed to excessive heat or steam.

STORAGE

Harnesses and Lanyard Assemblies need to be stored in a clean, cool, dry area free of chemical fumes or corrosive elements.

Never store in areas where there is direct sunlight. Preferably, equipment should, when not required for use, be kept in properly designed cabinets which permit ventilation.

In making provision for storage, it should be kept in mind that no part of the equipment be subjected to unnecessary strain, pressure, excessive heat or humidity. During storage, it should not be possible for the equipment to come into contact with sharp implements, corrosives or other likely causes of damage.

For particular and more specific information on selection and maintenance of Equipment consultation of AS/NZS 1891.4 should be undertaken.

Owners Name: _____
Product Serial No.: _____
Date of Manufacture: _____
Remove from Service Date: _____

INSPECTION RECORD CARD

A competent person must examine all Harnesses, Lanyard Assemblies and Pole Straps at least once every 6 months as instructed and record below. Fall Arrest Devices (SRL's) require a competent person to check at minimum every 3 months.

Visual Examination Date	Signature of Authorised Examiner	Visual Examination Date	Signature of Authorised Examiner

WARRANTY

Express Warranty – MSA warrants that the product furnished is free from mechanical defects or faulty workmanship for a period of one (1) year from first use or eighteen (18) months from date of shipment, whichever occurs first, provided it is maintained and used in accordance with MSA's Instructions and/or recommendations. Replacement parts and repairs are warranted for ninety (90) days from the date of repair of the product or sale of the replacement part, whichever occurs first. MSA shall be released from all obligations under this warranty in the event repairs or modifications are made by persons other than its own authorized service personnel or if the warranty claim result from misuse of the product, No agent, employee or representative of MSA may bind MSA to any affirmation, representation or modification of the warranty concerning the goods sold under this contract. MSA makes no warranty concerning components or accessories not manufactured by MSA, but will pass on to the Purchaser all warranties of manufacturers of such components. THIS WARRANTY IS IN LIEU OF ALL OTHER WARRANTIES, EXPRESS, IMPLIED OR STATUTORY, AND IS STRICTLY LIMITED TO THE TERMS HEREOF. MSA SPECIFICALLY DISCLAIMS ANY WARRANTY OF MERCHANTABILITY OR FITNESS FOR A PARTICULAR PURPOSE.

Exclusive Remedy – It is expressly agreed that the Purchaser's sole and exclusive remedy for breach of the above warranty, for any tortious conduct of MSA, or for any other cause of action, shall be the repair and/or replacement, at MSA's option, of any equipment or parts thereof, that after examination by MSA are proven to be defective. Replacement equipment and/or parts will be provided at no cost to the Purchaser, F.O.B. Purchaser's named place of destination. Failure of MSA to successfully repair any nonconforming product shall not cause the remedy established hereby to fail of its essential purpose.

Exclusion of Consequential Damages – Purchaser specifically understands and agrees that under no circumstances will MSA be liable to Purchaser for economic, special, incidental, or consequential damages or losses of any kind whatsoever, including but not limited to, loss of anticipated profits and any other loss caused by reason of the non-operation of the goods. This exclusion is applicable to claims for breach of warranty, tortious conduct or any other cause of action against MSA.

For additional information please contact the Customer Service Department at AUST: **1300 728 672** NZ: **0800 441 335**

