

Having trouble?

Many issues can be resolved in two simple steps:



1. Check your connections.

Verify that cables, cords, and filters on all devices are connected as specified in steps 1A–1E. Make sure:

- The dual-port filter (optional) is plugged into the wall jack (and not the Wireless Gateway).
- The data cable is plugged into the DSL port on the dual-port filter.
- Your phone cable is connected to the Phone port on the dual-port filter.

Cables usually make an audible “click” when secure. If connections are secure and you are still unable to connect to the Internet, try another wall jack. If you have traditional phone service, plug a phone directly into the wall jack to confirm dial tone.

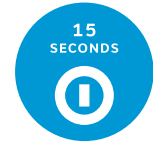

2a. Power down, power up.

Shut down your computer, and unplug the black power cord and any other devices from the back of the Wireless Gateway. Wait 15 seconds and then plug devices back in, making sure the Wireless Gateway's Power light is on. You should see a solid green Power light indicating a successful power connection (if the light is not on, try another electrical outlet). Then turn your computer back on.

2b. Wait for blinking indicator lights.

Wait for blinking indicator lights to turn solid green (may take up to two minutes), and then attempt to access the Internet.

Specific issues

I have a monitored home security system or health alarm.
You will need to contact your home security and/or health alarm providers after completing all of the installation steps in this guide to ensure that their services have not been affected.

My Power indicator light turns amber during the power up sequence.
Don't worry. This is a normal part of the power up sequence—just remember not to unplug the power cord or green data cable when the light is still amber. At the end of the sequence, the Broadband and Service indicator lights will be solid green.

Where can I go for further installation assistance or to download the online support tool?
For further installation assistance or to download the online support tool for features configuration, such as wireless networking service, go to uverseactivation.att.com.

Why do I need to install phone line filters?
Without a DSL filter, you may experience disruptions or hear static on the phone line. You may purchase additional filters (including

wall mount filters) from the AT&T Store at att.com/equipment or at most electronics and computer stores. While AT&T services generally work with third-party devices, they are not specifically supported by AT&T.

There's static on the phone line.
Make sure there are port filters properly installed on all phone devices, digital video recorders, monitored alarm systems, satellite systems, fax machines, cable systems, and any other devices plugged into a wall jack.

Every time I try to browse a Web page, I get a message saying "Detecting Proxy Settings."
In Internet Explorer, under Tools > Internet Options > Connections > Settings, uncheck any checked boxes and click OK.

Additional AT&T U-verse information

Check out the User Guide:

Now that you have successfully installed AT&T U-verse Internet, check out the Internet User Guide for more information about your email and security features. This guide is also available online at support.att.com/userguides.

Go online:

To manage your AT&T U-verse account, go to att.com/uversecentral.

¿Habla español?

Para las guías en español, visitar support.att.com/userguides.

Need more help?

Go online: Visit att.com/uversesupport.

Call us: Dial **1.800.288.2020** and ask for “U-verse technical support.”



AT&T U-verse® High Speed Internet

Wireless Gateway

SELF- INSTALLATION GUIDE

Before installation:

Do not attempt to install your services until 8pm or later on your service activation date. You can find this date on your packing slip.

Get started

Approximate installation time: 45 minutes

Before you begin:



1. Check your service activation date.

Do not attempt to install your service until **8pm or later** on the date provided to you by AT&T. This date is also located on your packing slip.



2. Do you have a monitored home security system or health alarm?

You will need to contact your home security and/or health alarm providers after completing all of the installation steps in this guide to ensure that their services have not been affected.

Gather materials needed for setup:

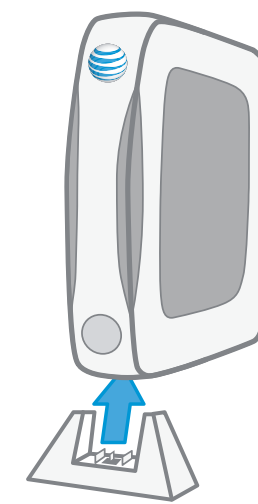

Wireless Gateway

The Gateway stand should fit snugly into the bottom of the Gateway toward the front and sit flat on the surface as shown above.



Dual-port filter

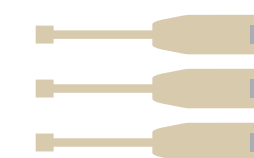

3 single-port filters



Ethernet cable (yellow)



Data cable (green)



Power cord, 2 parts (black)

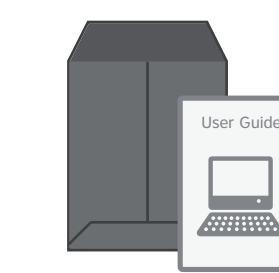

High Speed Internet User Guide support materials



Your 4-digit passcode. You received a separate letter confirming the 4-digit passcode you designated when placing your order.

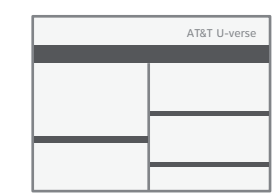

Packing slip



1 Set up Approximate time: 10 minutes

Customers without traditional phone service can skip steps A and B, and start with step C.

A If you have traditional phone service, install single-port filters in wall jacks that have devices such as phones, fax machines, satellite receivers, or modems.

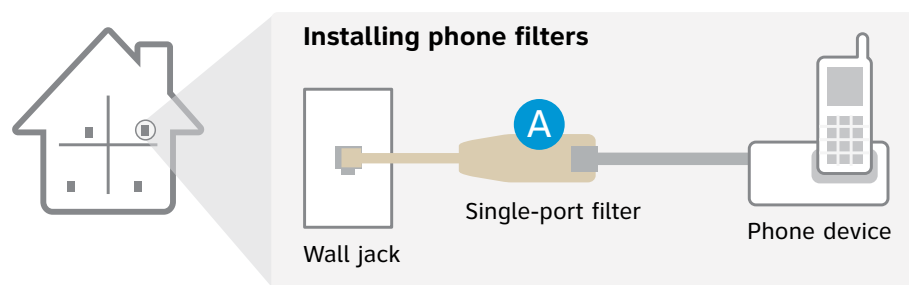

B The dual-port filter is used when you want to connect a phone or other piece of equipment, such as a fax machine, to the same wall jack as your Wireless Gateway.

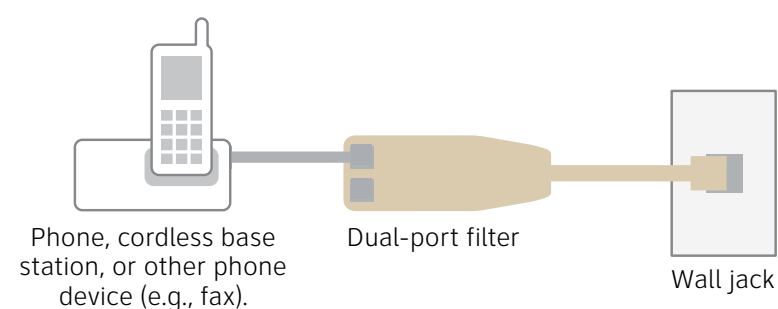

C Connect the green data cable from the Wireless Gateway's Phone Line port to the dual-port filter's DSL port (or directly to the wall if you do not have traditional phone service).

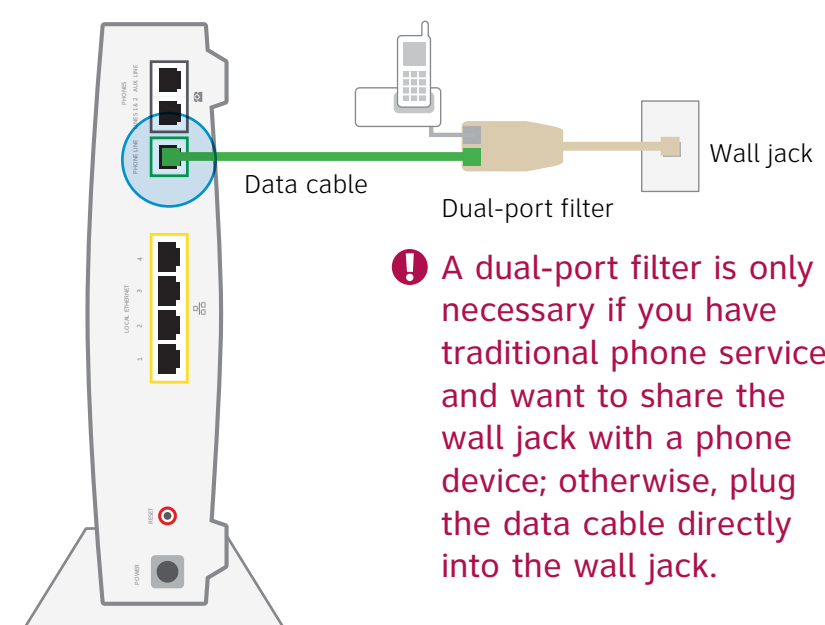

D Connect the yellow Ethernet cable from the Wireless Gateway's Local Ethernet port to your computer's Ethernet port.

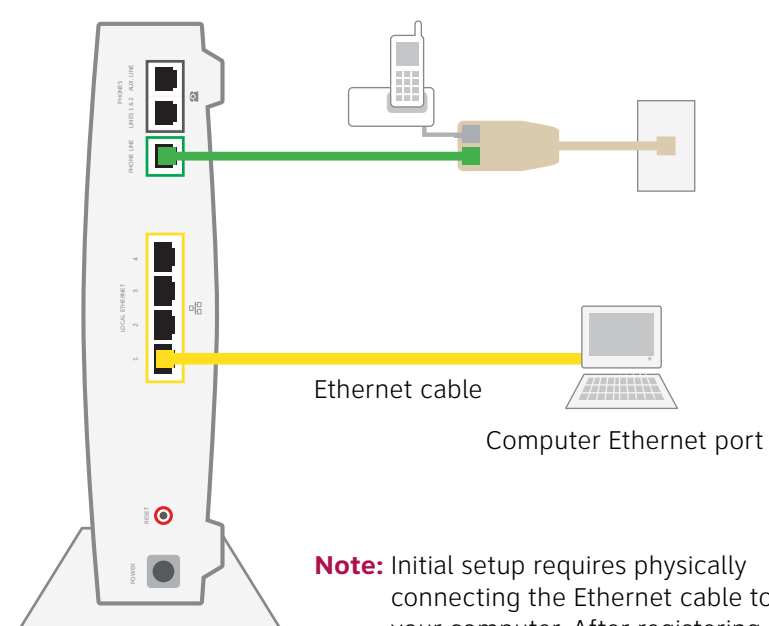

E Combine the two-part power cord (P1, P2), and then connect one end to the Wireless Gateway's Power port and the other end to an electrical outlet.

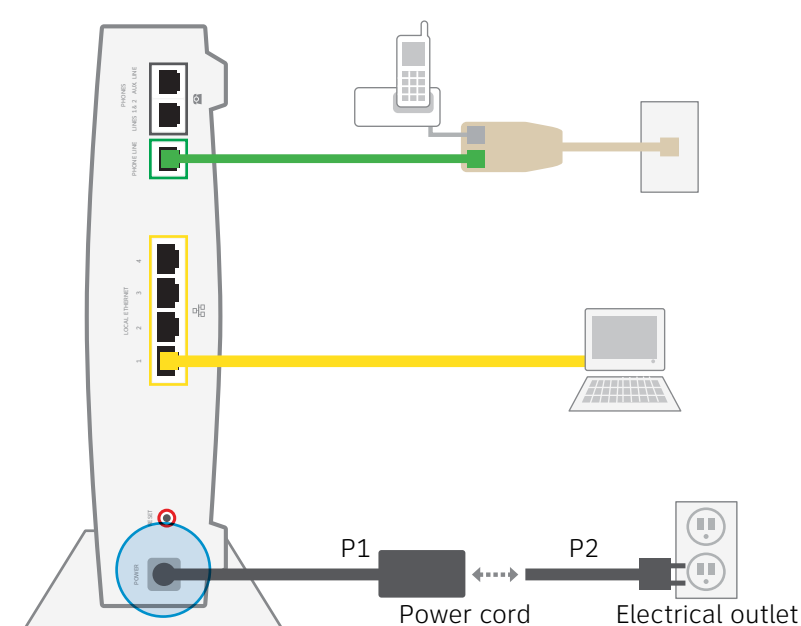

2 Power up Approximate time: 5 minutes

Your Wireless Gateway is now powering up. During this time, the Broadband light will turn red. Wait up to five minutes for the indicator lights for Broadband and Service to turn solid green and the Local Ethernet indicator light to start blinking green.

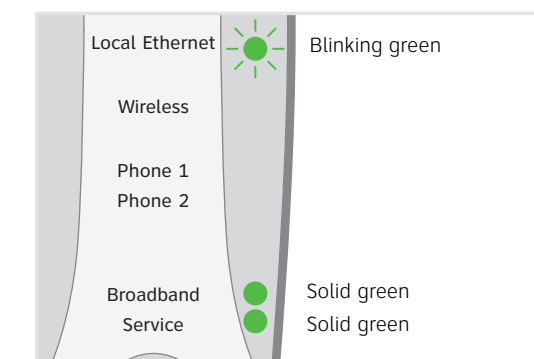

! During this time, do not unplug the power cord or green data cable, as this can damage the Wireless Gateway.

If the Broadband and Service lights do not turn solid green or continue to blink after 10 minutes, see the "Having trouble?" section on the back of this guide.

Note: During the power up sequence, the **Power light may turn amber** and the Wireless Gateway may reset, which is a normal part of the power up sequence.

3 Mandatory registration Approximate time: 20 minutes

- Open your Internet browser (e.g., Internet Explorer, Safari, etc.). The online registration process will start automatically to assist you in activating your service. If it does not, enter **lsreg.att.net** into your address bar.
- Continue with online registration using the 4-digit passcode you created when you placed your order—it was mailed to you separately for your reference.



4 Adding other wireless devices (optional) Approximate time: 10 minutes

Write down your Network Name (SSID) and Wireless Network Key (WPA) to configure a wireless device. This information is on the side of your Wireless Gateway. The Network Name consists of "2WIRE" plus the last three digits of the Wireless Gateway's serial number. Be sure to record this information in the form below.

Now configure your wireless network:

- Go to your computer's "Wireless Network Settings" and refresh the network list.
- Select your Network Name (SSID) from the list. You may need to scroll through the list to find your SSID.
- Enter the 10-digit Wireless Network Key (WPA) in the Password field to connect to your network.

SN: 2304110000
For Advanced Configuration: <http://192.168.1.254>
System Password: 1234567890
Mac Address: 9876543210
Wireless Network Key: 1234567890

Network Name (SSID)
2 W I R E [] [] [] [] [] [] [] [] [] []

10-digit Wireless Network Key (WPA)
[] [] [] [] [] [] [] [] [] []

Congratulations! You should now be wirelessly connected to the Internet.

Questions?

Go online: Visit att.com/versesupport.

To learn more about the benefits and features of your AT&T U-verse service, visit att.com/u-verse/newcustomer.

Stay connected on the go!

AT&T Wi-Fi Basic is included with your AT&T U-verse High Speed Internet service, so you can access the Internet at thousands of AT&T Wi-Fi Hot Spots across the country. Visit attwifi.com to learn more.

