

---

ABB MEASUREMENT & ANALYTICS

## Millmate roll force systems

Reliable, long-term solutions  
for your roll force measurement



---

## Measurement made easy

### **Millmate roll force systems**

Quality measurement technology  
for optimum process control

- Accurate
- Rugged
- Reliable

# Millmate roll force systems

## Introduction

A measurement technology offering high accuracy is a prerequisite for modern rolling mills of today.

—  
01 System overview  
ABB's Millmate rollforce  
system in rolling mills

The constant striving to achieve optimum process quality and the highest possible productivity is the essential goal of modern production units.

Rolled products are called upon to meet ever stricter demands, and as a consequence so is also rolling mill equipment. A truly measured roll force is crucial in achieving correct roll gap settings, true force distribution from operator side to drive side of your mill and supervision of the backup bearings and roll eccentricity.

The Millmate roll force system incorporates all these essential features.

The Millmate roll force load cells act as integrated parts of the mill stand. The rock-solid Pressductor® load cell design in combination with the intelligent and reliable communication functions are crucial keys to true roll force measurement.

The Millmate roll force system consists of a Millmate Controller (MC 400) and two load cells with matching units. The various types and the wide load range of Millmate roll force load cells cover practically all conceivable roll force measurement applications.

The ABB equipment is easy to install and operate. We offer installation support as well as long-term after sales supply and support. Due to ABB's extensive experience in the rolling mill industry, we can offer outstanding application know-how in this particular field.

—  
01

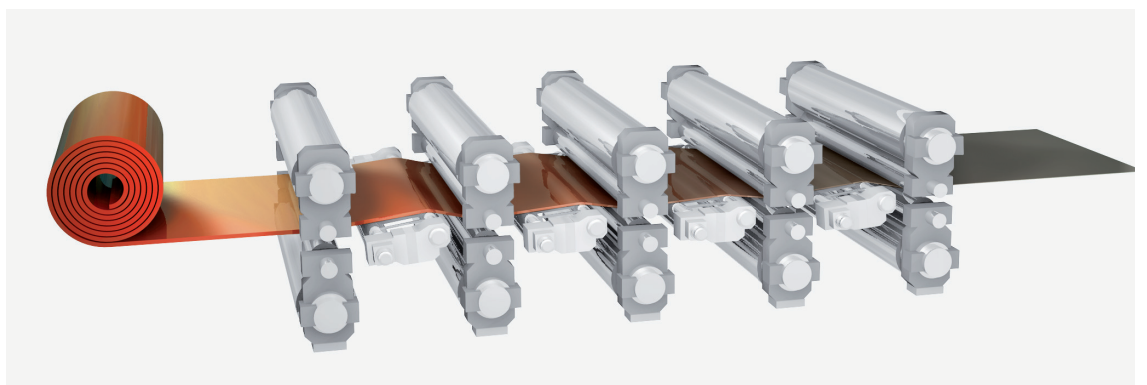
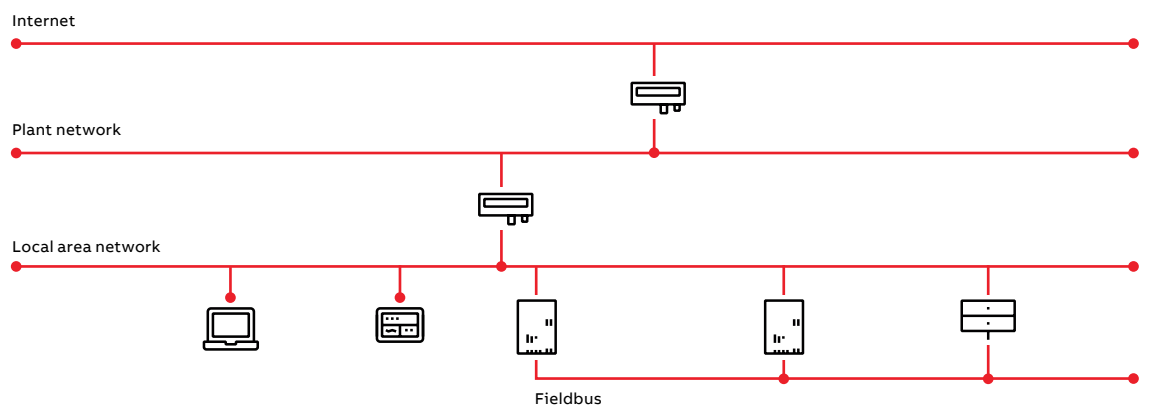

# Pressductor® Technology

## Measurement principle

ABB's Millmate roll force load cells are based on the well-known Pressductor® principle patented in 1954, utilizing the magneto-elastic effect, according to which the magnetic properties of steel are influenced by mechanical forces acting on it.

—  
01 700% of nominal load. The highest permissible single loading without mechanical damage to the load cell

300% of nominal load. The highest permissible load without permanent change of data

—  
02 Load cell application in hot rolling mill

—  
03 The measurement principle is based on the magneto-elastic effect, according to which the magnetic properties of the material are influenced by mechanical stress. The transducer is magnetized via the primary coil.

An electrical voltage proportional to the applied force is induced in the secondary coil

—  
04 Load cell application in cold rolling mill

In the transducer body there are four holes. Two coils at right angle to each other are wound through these holes. One winding (the primary) is supplied with an alternating current; the other winding (the secondary) acts as a measurement winding. Since the two windings are at right angle to each other, there is no magnetic coupling between them as long as there is no load acting on the transducer body.

If the transducer body is loaded (as shown in figure 3), the field pattern changes. The permeability of the steel is reduced in the direction of the force and increase in the direction at right angles. The result is a change in the symmetry of the magnetic flux, so that some of the flux induces a voltage in the secondary winding. The induced voltage is proportional to the load.

**Right from the beginning of the Pressductor era a transducer based on this measurement principle turned out to be perfect for the rolling mill environment.**

### The key factors are:

- No compression of the transducer is needed to achieve a reliable signal corresponding to the applied force.
- An overload capacity of up to 700 % is achieved by utilizing only a small part of the elasticity of steel.
- The standard load cell consists of 1,500 to 2,000 transducers, always ensuring a true roll force measurement, even if the load is unevenly distributed.
- Signal-to-noise level is outstanding due to the high signal output from the load cell (500 mV).

The rock-solid design of the Pressductor load cells fulfils these key factors and will assure you many years of accurate measurements in your rolling mill.

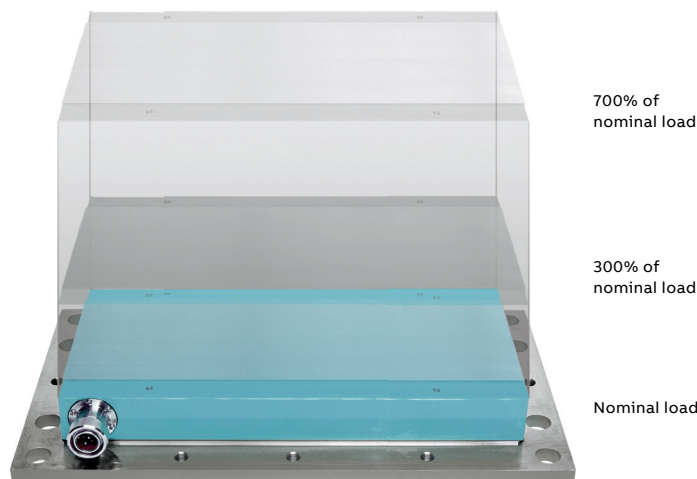

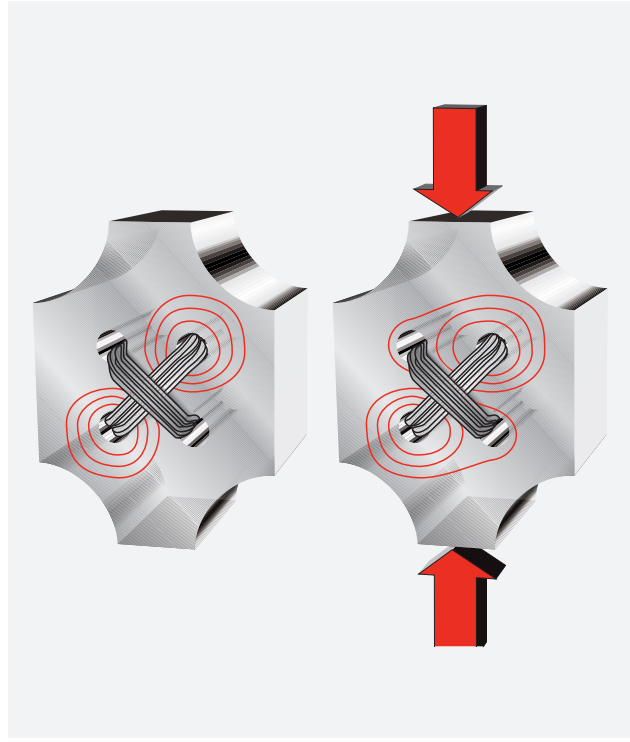
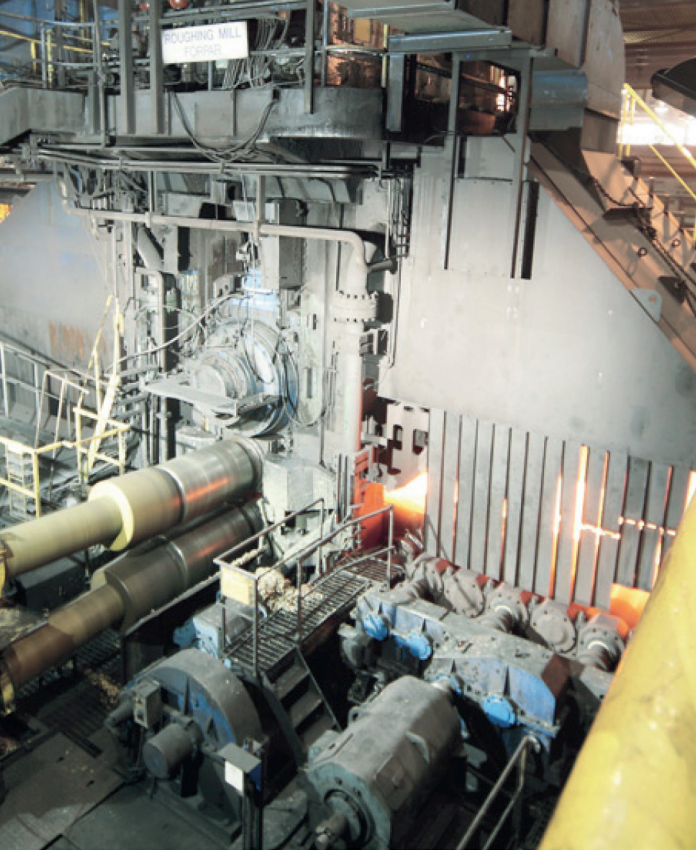

# ABB's force measurement systems in rolling mills

—  
01 Overview of load cells and electronics

—  
02 A 4-high mill stand with removed work rolls

—  
03 View of hot rolling mill from operator room

—  
04 Hot rolling mill

## Your selection of load cells, control units and options

ABB's Roll force systems offer a comprehensive selection of load cells, control units and options covering your needs for accurate and reliable roll force measurement in your rolling mill.

You choose from the Millmate roll force load cells coming in three different versions: Circular, Rectangular and Annular. The most common installation application for the circular version is under the mill screw. The rectangular version is normally installed under the lower back-up roll bearing housing.

The annular version is installed between the mill nut and the mill stand. The choice of control unit is made in the light of system requirements and according to your communication needs.

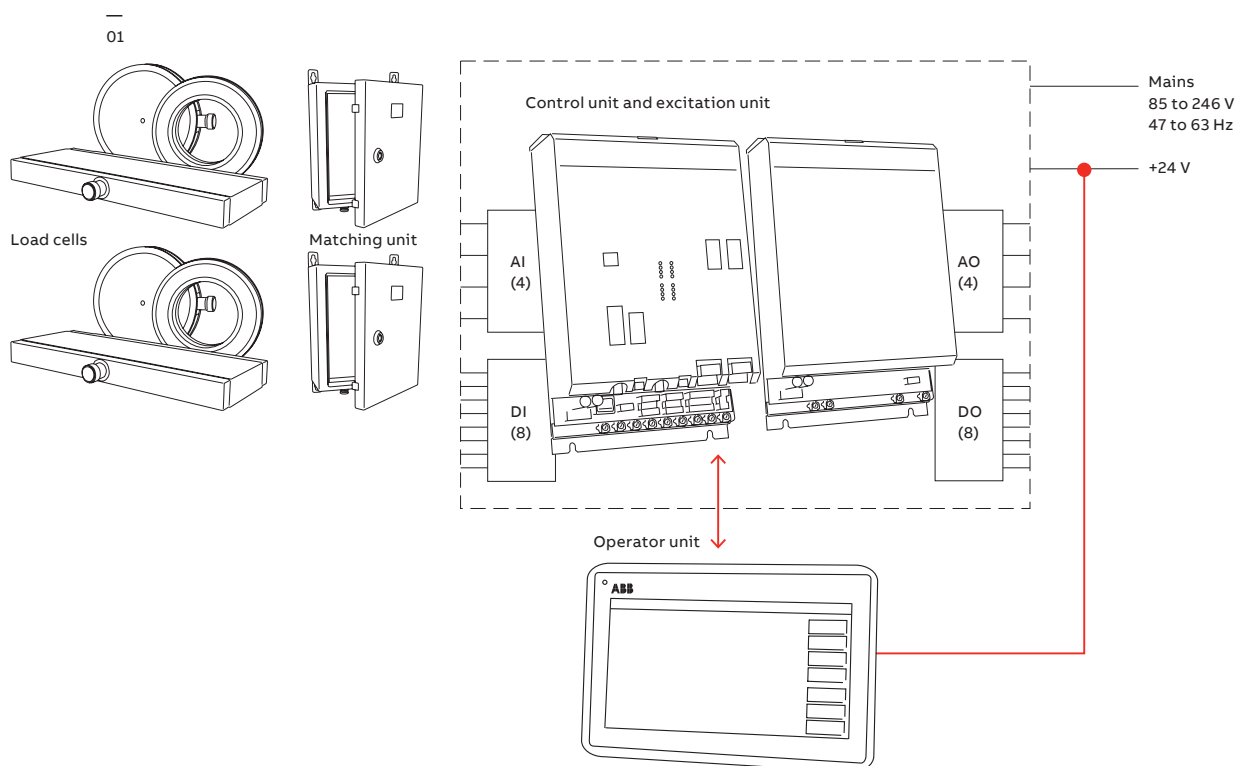



# Load cells

The heavy-duty Millmate roll force load cells have high stability components protected by a stainless steel box providing the built-in calibration and temperature compensation of the load cell.

—  
01 4-high mill stand  
—  
02–04 Load cells can be installed in several different ways, but the preferred arrangement, from both the economical and technical points of view, is usually to install the load cell under the mill screw.

Due to its low impedance and high output signal power the Millmate roll force load cell has an extremely low sensitivity to insulation defects and maintains its measuring accuracy at insulation levels down to 10 k $\Omega$ .

The load cell output signal is calibrated for full interchangeability between load cells of the same type and size. The various types of load cells and the wide load range cover practically all conceivable roll force measurement applications.

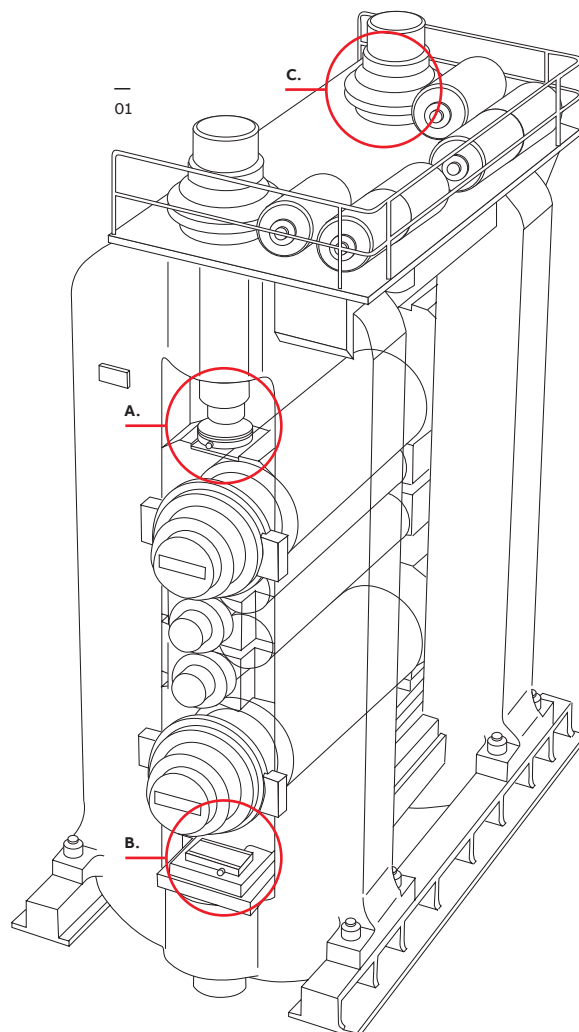

## Circular load cells PFVL 141C for mounting under the mill screw or hydraulic cylinder

Circular load cells are installed above the upper back-up roll bearing housing. The load cell can be combined with thrust bearings and pressure plates into a package attached to the mill screw or hydraulic cylinder. This arrangement results in good force distribution, simple, inexpensive installation and easy servicing. In addition, there is no need to machine any surfaces on the roll stand. However, this arrangement does take up space in the roll window.

The circular load cells are machined from a quadratic core. Shrunk-on stainless steel rings protect the load cell windings and underlying components. There is a choice of core diameters in multiples of 30 mm, giving 23 different standard sizes for forces between 2.0 to 60 MN.

—  
02

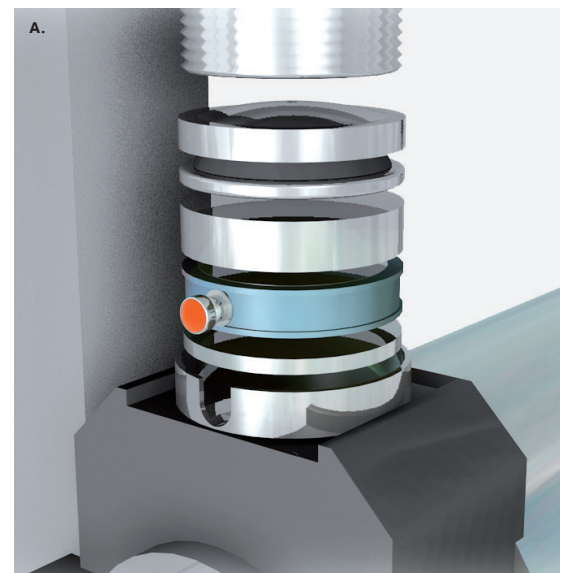



**Rectangular load cells PFVL 141V for mounting under the lower back-up roll bearing housing**

There must be a sufficiently large flat surface on the lower part of the roll stand to allow the installation of the load cell under the lower back-up roll bearing. This arrangement has the advantage that there is no need to pay particular attention to the load cell during roll change. See also our offer regarding Load Cell Packages on the next page.

The load cell can be adapted to the required dimensions, and the length is chosen as a multiple of 30 mm. For load cells longer than 900 mm, the chosen length must be a multiple of 60 mm. The width is chosen as a multiple of 30 mm. Stainless steel side-bars protect the load cell windings and underlying components. This load cell type is available in standard sizes from 0.63 to 60 MN.

**Annular load cells PFVL 141R for mounting between the mill screw nut and the mill stand**

This version makes measurement possible even if the space under the mill screw and under the lower back-up roll bearing is insufficient. This arrangement also has the advantage that there is no need to pay particular attention to the load cell during roll changing, and it is well protected.

The annular load cell consists of stainless steel laminations wound on an annular stainless steel core, after which an outer stainless steel ring is shrunk on to the load cell to protect the load cell windings and underlying components. Standard sizes of annular PFVL141R load cells are available from 2.0 to 28 MN. For smaller loads, QGPR 104/102 load cells are available from 0.1 to 2.5 MN.

03

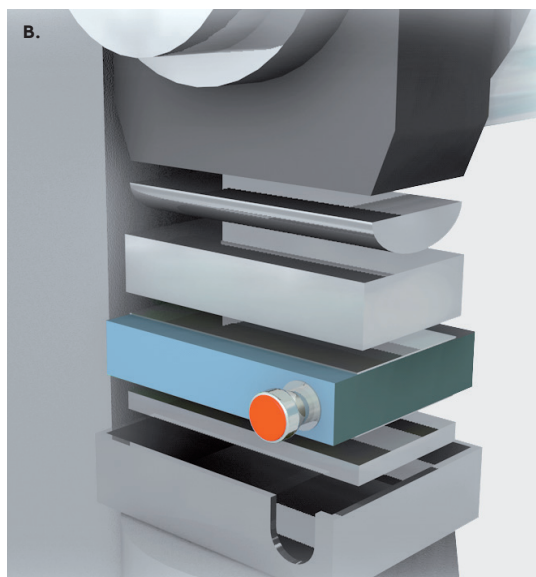

04

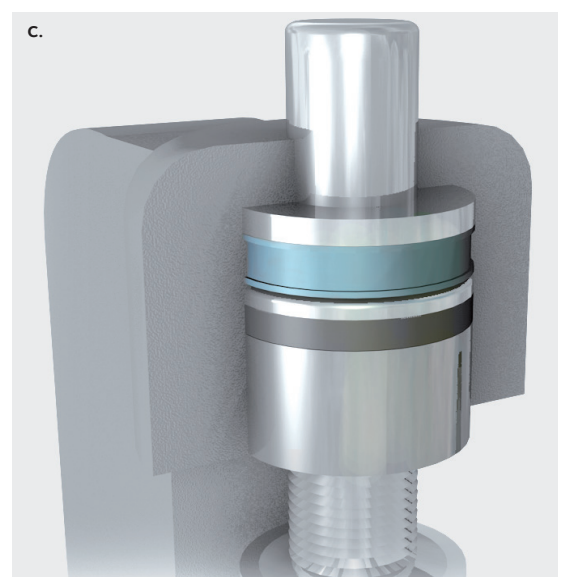

# Load cells

## Installation arrangements

—  
01 ABB offers a complete range of roll force load cells of different types and sizes. Connector cables to be preferred to fixed cables.

—  
02 Step-by-step assembly of our prestressed Load Cell Package

### Load cell packages

When the load cell is positioned under the lower back-up roll bearing, which is the most exposed position, we can offer a pre-stressed package with lower pressure plate, load cell, frame and upper pressure plate.

The safe and compact Load Cell Package secures easy and correct installation. You increase the possibility of accurate measure, and can count on a longer lifetime and lower maintenance costs.

### ABB has many years of experience of installing load cells in all types of rolling mill.

To achieve the best possible measurement results, certain basic rules must be observed during the installation of the load cell:

- The entire force must pass through the load cell.
- The force must be measured as close to the source of the force (the roll gap) as possible.
- The load cells must be protected to the greatest possible extent from large bending, lateral and torsional forces.

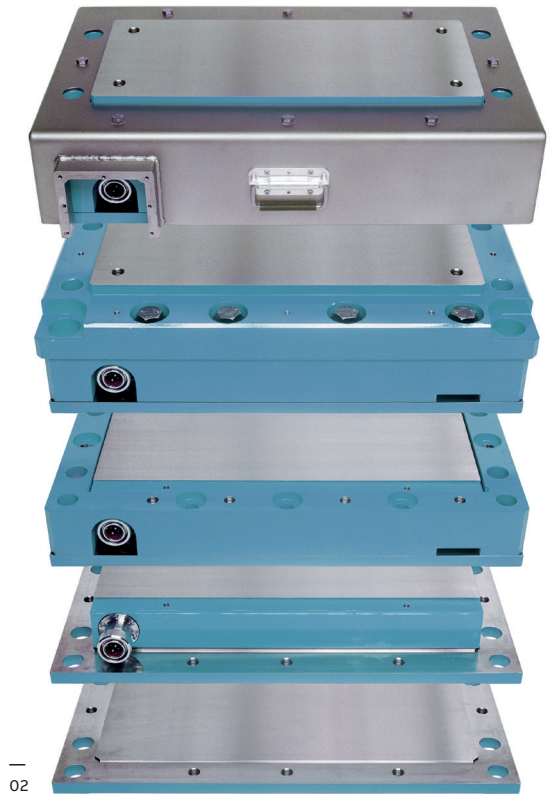

—  
02

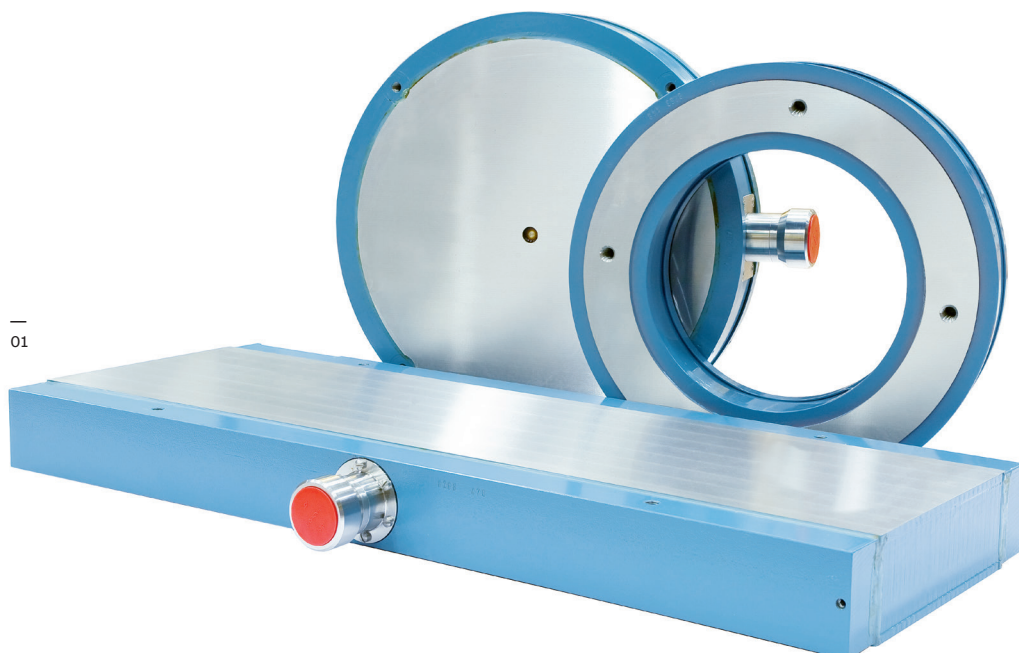

—  
01

# Circular load cells

## PFVL 141C, measurement range 2.0–60 MN

### Standard sizes and cable lengths

Load cells are manufactured in the standard range as below.

Nominal load (MN)	ID (mm)	OD (mm)	Max. cable length (m) 2 load cells <sup>1)</sup>	Max. cable length (m) 4 load cells <sup>1)</sup>
2.0	150	210	30	17
2.5	180	240	30	17
3.1	210	270	28	16
4.0	240	290	28	15
5.0	270	320	28	15
6.3	300	350	25	12
8.0	330	380	25	11
10	360	410	24	10
12.5	390	440	23	8
14	420	470	22	6
16	450	500	22	–
18	480	530	21	–
20	510	560	20	–
22	540	590	19	–
25	570	620	18	–
28	600	650	17	–
31	630	710	16	–
35	660	740	15	–
40	720	800	13	–
45	750	830	12	–
50	780	860	10	–
51.5	810	890	10	–
56	810	890	8	–
60	810	890	8	–

<sup>1)</sup> Max cable length between load cell and matching unit if 2 or 4 load cells are connected to the same control unit.

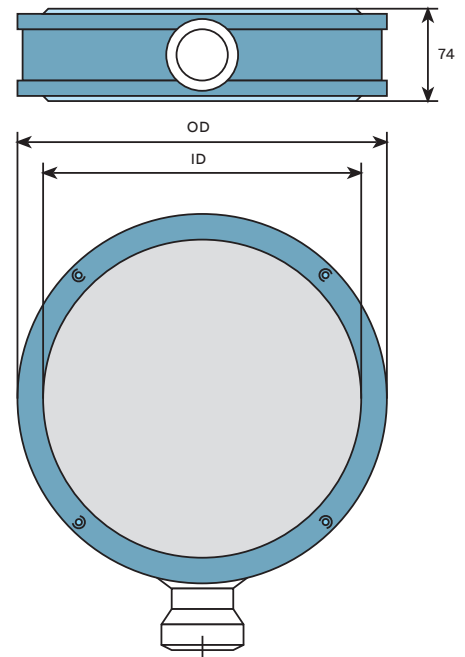

### Select as follows:

- Determine the load for which the load cell is to be used and choose from the table the next higher value in the standard range.

### When ordering, please state:

- Type designation
- Nominal load

### Example

Nominal load 20 MN per load cell.  
Select 20 MN load cell, dimension  
OD=560 mm, ID=510 mm.  
PFVL 141C, 20 MN

# Rectangular load cells

## PFVL 141V, measurement range 0.63–60 MN

### Standard sizes and cable lengths

Load cells are manufactured in the standard range as below.

Nominal load (MN)	Max. cable length (m) 2 load cells <sup>1)</sup>	Max. cable length (m) 4 load cells <sup>1)</sup>
0.63	30	17
0.8	30	17
1.0	30	17
1.25	30	17
1.6	30	17
2.5	30	17
3.1	28	16
4.0	28	15
5.0	28	15
6.3	25	12
8.0	25	11
10	24	10
12.5	23	8
14	22	6
16	22	–
18	21	–
20	20	–
22	19	–
25	18	–
28	17	–
31	16	–
35	15	–
40	13	–
45	12	–
50	10	–
51.5	10	–
56	8	–
60	8	–

<sup>1)</sup> Max cable length between load cell and matching unit if 2 or 4 load cells are connected to the same control unit.

Length (L) mm		
120	480	840
150	510	870
180	540	900
210	570	960
240	600	1020
270	630	1080
300	660	1140
330	690	1200
360	720	1260
390	750	1320
420	780	–
450	810	–

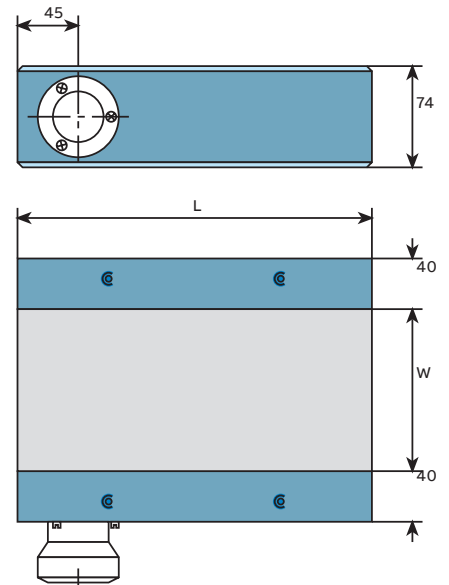

Width (W) mm	
70	430
100	460
130	490
160	520
190	550
220	580
250	610
280	–
310	–
340	–
370	–
400	–

### Select as follows:

- Determine the load for which the load cell is to be used and choose from the table the next higher value in the standard range.
- Determine either the width or length of the load cell and calculate the other dimension using the following formula:
  - $L \times W \times 0.0001 = F$
  - L = load cell length in mm
  - W = load cell width in mm
  - F = nominal load of load cell in MN (taken from the standard series in the table)
  - Width and length are rounded up to the next higher value in the table.

### When ordering, please state:

- Type designation
- Nominal load
- Width and length

### Example

With a nominal load of 14 MN and a width of 370 mm the length will be 390 mm (rounded up from 378 mm).  
 PFVL 141V, 14 MN  
 L=390 mm, W=370 mm

# Annular load cells

## PFVL 141R, measurement range 2.0–28 MN

### Standard sizes and cable lengths

Load cells are manufactured in the standard range as below.

Dimensions can be designed to order on request.

Nominal load (MN)	D <sub>1</sub> (mm)	D <sub>2</sub> (mm)	D <sub>3</sub> (mm)	D <sub>4</sub> (mm)	Max. cable length L (m) 2 load cells <sup>1)</sup>	Max. cable length L (m) 4 load cells <sup>1)</sup>
2.0	100	130	200	240	30	30
2.5	100	130	210	250	30	30
3.1	200	230	300	340	28	28
4.0	225	255	340	380	28	28
5.0	255	285	380	410	28	28
6.3	285	315	420	450	25	25
8.0	320	350	470	500	25	25
10	355	385	525	555	24	10
11.2	375	405	550	580	23	8
12.5	400	430	590	620	22	8
14	420	450	620	650	22	6
16	450	480	660	690	21	–
18	480	510	700	730	20	–
20	505	535	735	765	19	–
22.4	535	565	775	805	18	–
25	565	595	820	850	17	–
28	595	625	865	895	8	–

<sup>1)</sup> Max cable length between load cell and matching unit if 2 or 4 load cells are connected to the same control unit.

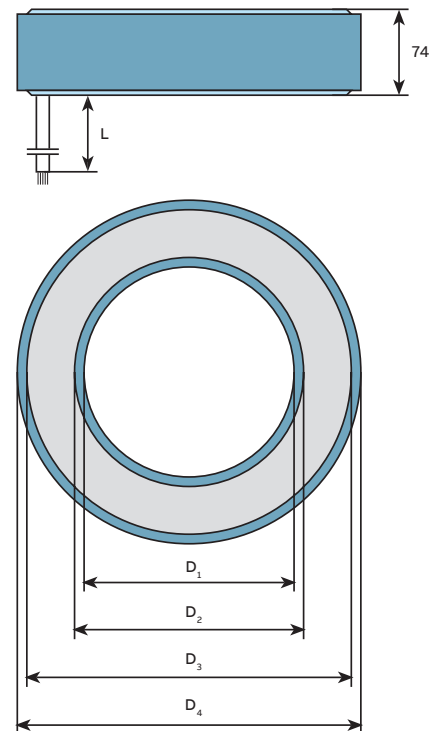

### Select as follows:

- Determine the load for which the load cell is to be used and choose from the table the next higher value in the standard range. We can customize load cells if a standard load cell is not suitable for a particular application.
- To calculate the load F for non-standard load cells:

$$F = \left( \frac{D_3^2 \pi}{4} - \frac{D_2^2 \pi}{4} \right) \times 0.0001 \text{ MN.}$$

### Example

PFVL 141R, 10 MN

D<sub>2</sub>=385 mm

D<sub>3</sub>=525 mm

# Small annular load cells

## QGPR 104/102, measurement range 0.1–2.5 MN

QGPR 104 and QGPR 102 load cells are mainly used in applications where the load to be measured or the available space in the installation is smaller than what is suitable or required for the smallest PFVL141R load cell. Examples of such installations are tube mills and smaller edger mills.

### Standard sizes and cable lengths

Load cells are manufactured in the standard range as below. Dimensions can be designed to order on request.

Nominal load (MN)		D <sub>1</sub> (mm)	D <sub>2</sub> (mm)	D <sub>3</sub> (mm)	D <sub>4</sub> (mm)	Max. cable length (m) 2 load cells <sup>1)</sup>
0.10	QGPR 104	35	59	79	103	20
0.16	QGPR 104	35	59	79	103	20
0.25	QGPR 104	35	59	79	103	20
0.40	QGPR 104	35	59	90	115	20
0.63	QGPR 104	50	80	120	150	20
1.0	QGPR 102	80	110	160	190	20
1.25	QGPR 102	120	150	200	230	20
1.6	QGPR 102	180	210	260	290	20
2.0	QGPR 102	190	220	270	300	20
2.5	QGPR 102	200	230	290	320	20

<sup>1)</sup> Max cable length between load cell and matching device if 2 or 4 load cells are connected to the same control unit.

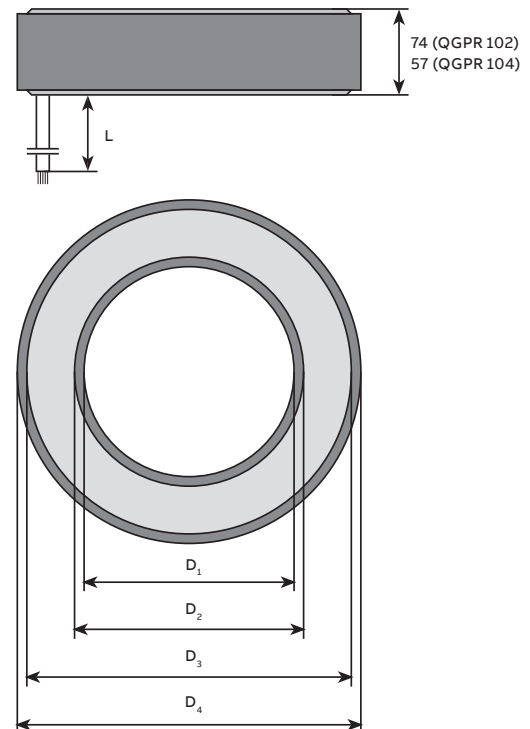

### Select as follows:

- Determine the load for which the load cell is to be used and choose from the table the next higher value in the standard range. We can customize load cells if a standard load cell is not suitable for a particular application.
- To calculate the load F for non-standard load cells:

$$F = \left( \frac{D_3^2 \pi}{4} - \frac{D_2^2 \pi}{4} \right) \times 0.0001 \text{ MN.}$$

# Load cells

## Data and definitions

		PFVL	QGPR
<b>Accuracy class</b>	% of $F_{nom}$	$\pm 0.5$	$\pm 1.0$
<b>Linearity deviation</b>	% of $F_{nom}$	$\leq \pm 0.5$	$\leq \pm 1.0$
<b>Hysteresis</b>	% of $F_{nom}$	$\leq 0.2$	$\leq 0.2$
<b>Repeatability error</b>	% of $F_{nom}$	$\leq \pm 0.1$	$\leq \pm 0.05$
<b>Compression</b>	(mm at $F_{nom}$ )	0.05	0.05
<b>Calibration error</b>	% of $F_{nom}$	0.1	0.1

**Nominal load ( $F_{nom}$ )** is the load for which the load cell is dimensioned and calibrated, i.e. the sum of the stationary load and the maximum measured load in the measuring direction.

**Accuracy class** is defined as the maximum deviation and is expressed as a percentage of the sensitivity at nominal load. This includes linearity deviation, hysteresis and repeatability error.

**Linearity deviation** is the maximum deviation from a straight line drawn between the output values of zero and nominal load, related to the nominal load.

**Hysteresis** is the maximum deviation of the output signal at the same load during a cycle from zero to nominal load and back to zero, related to the sensitivity at nominal load. The hysteresis is proportional to the cycle.

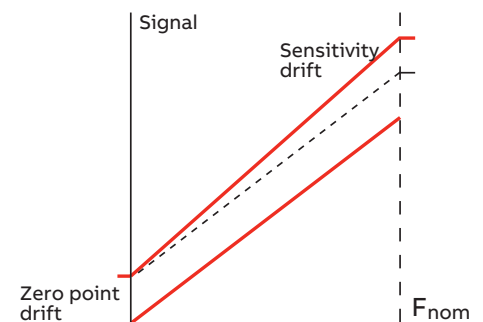
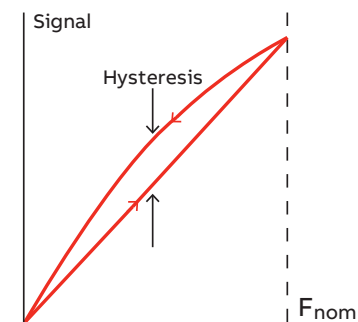
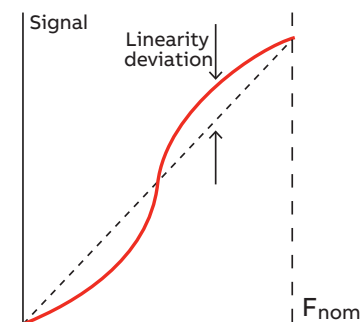

	PFVL	QGPR
<b>Compensated for min. error</b>	+20 to +80°C	+20 to +80°C
- Zero point drift	$\leq \pm 0.01\%/^{\circ}\text{C}$	$\leq \pm 0.005\%/^{\circ}\text{C}$
- Sensitivity drift	$\leq \pm 0.01\%/^{\circ}\text{C}$	$\leq \pm 0.01\%/^{\circ}\text{C}$
<b>Working temperature range</b> <sup>1)</sup>	-10 to +90°C	-10 to +80°C
<b>Storage temperature range</b>	-40 to +90°C	-40 to +90°C

1) Max. permitted short-term temp. +110°C

**Repeatability error** is defined as the maximum deviation between repeated readings under identical conditions. It is expressed as a percentage of the sensitivity at a nominal load.

**Compression** is the total reduction in the height of the load cell when the load is increased from zero to nominal load.

**Zero point drift** is defined as the drift in the output signal when there is no load on the load cell.

**Sensitivity drift** is defined as the drift in the output signal at nominal load, excluding the zero point drift.

# Control unit

## Millmate Controller 400

01 Millmate Control unit with excitation unit

The control unit supplies the load cells with power, processes the signals from the load cells and communicates the result to other systems. Communication can take place via digital inputs/outputs, analog inputs/outputs, TCP/IP-communication, RS-232 and as an option, via high-speed fieldbus.

The control unit can be manually operated using the Millmate Operator Unit 410 and by external units via a serial interface or digital/analog inputs. Setup and commissioning are easy following step-by-step menus.

Measured values are displayed on the operator unit, connected to analog outputs or transmitted via a serial interface to an external display or to other external units.

### Features

The Millmate Controller 400 has been designed to offer a lot of functionalities and at the same time very easy to use.

The control unit covers most mechanical arrangements. This means the user only has to follow the step-by-step menus in order to set up the control unit and to obtain correct roll force measurement.

### Some examples of the built-in functionalities:

- Predefined standard measurement modes
- Built-in load cell tables
- Filter times from 1 up to 2000 ms
- Easy configurable analog/digital inputs/outputs
- Level detectors
- Unit selection (N, kN, MN, kp, t, lb, T)
- Self-diagnostics test system including transducer test
- Simulation mode for easy check of system integration

01



Millmate Controller 400		
Version	Number of load cells	Communication
PFVA 401	2 PFVL141	VIP
PFVA 401 S	4 PFVL141	VIP
PFVA 401 F	2 PFVL141	VIP + Profibus
PFVA 401 SF	4 PFVL141	VIP + Profibus
PFXA 401	2 QGPR 104/102	VIP
PFXA 401 S	4 QGPR 104/102	VIP
PFXA 401 F	2 QGPR 104/102	VIP + Profibus
PFXA 401 SF	4 QGPR 104/102	VIP + Profibus



# Data

## External connections:

- Excitation current to the load cells
- 2 or 4 analog inputs for load cell signals
- 4 analog outputs, voltage or current
- 8 digital inputs for control signals
- 8 digital outputs
- +24 V supply for external units, max 0.5 A
- Ethernet for connection to:
  - other Millmate control and operator unit
  - other control systems with VIP protocol
- 2 serial interfaces of type RS-232 for external displays, control, etc.
- High-speed Profibus (optional)

If 4 PFVL load cells are connected to the same control unit the nominal load is max. 14 MN for each load cell. PFVL141 and QGPR 104/102 load cells cannot be mixed in the same control unit. Analog/digital inputs and outputs are galvanically insulated as groups.

## Vendor Internet Protocol (VIP)

Other control systems can send control data and monitor measurement data with TCP/IP-communication.

## The Ethernet

connection together with the Vendor Internet Protocol (VIP) is used for communication. The protocol uses configurable predefined data telegrams and the Millmate Controller 400 acts as a server. The sending procedure is cyclic and the receiving procedure reacts on incoming messages.

## The PROFIBUS option

As an option the control unit can be equipped with PROFIBUS – a vendor-independent, open-communication standard for automation in manufacturing and process control.

The Profibus interface in the Millmate Controller 400 is updated with a new complete set of measuring values every 0.3 milliseconds, 1.5 ms for QGPR 104/102.

<b>Millmate Controller 400</b>		<b>PFVA401 (PFXA 401 with PFVI 401)</b>
Dimensions (H x W xD), two pieces <sup>2)</sup>		380 x 235 x 90 mm each
Weight <sup>2)</sup>		5 kg + 8 kg
Protection class <sup>1)</sup>		IP 20
Main voltage		85 to 264 V, 100 (-15 %) to 240 V (+10 %)
Power consumption		650 VA (140 VA for QGPR 104/102 installation)
Excitation current		2 A
Operating temperature		0 to +70 °C
Storage temperature		-40 to +70 °C
Analog inputs		Load cell connection, 2 or 4
Analog outputs	Voltage	0 to ±10 V
	Current	0 to ±20 mA, 4 to 20 mA (insulated as group)
	Step response	1 ms (0 to 90 %), 5 ms for QGPR 104/102
Digital inputs		0/+24 V insulated 4 + 4
Digital outputs		0/+24 V insulated 4 + 4

1) According to IEC 529, EN 60-529

2) PFVI401 not needed for QGPR 104/102 load cells

## VIP

Network	10 Mbit/s Ethernet
Communication rate	10 messages/s
Error handling	Automatic retransmission

## Profibus-DP

Station type	Slave
Maximum speed	12 Mbit/s
Configuration	Printable GSD-file in control unit

# Control unit accessories

- 01 Millmate Operator Unit 410. Dimensions 143 x 204 x 50 mm (H x W x D), IP 65 from the front when mounted on a panel acc. to IEC 529, EN 60-529, IP 20 in all other directions acc. IEC 529, EN 60-529, weight 0.8 kg.
- 02 Relay board PFVK 128
- 03 Insulation amplifier PXUB 201. Voltage output: 0 to ± 10 V or current 0 to ± 20 mA

## Millmate Operator Unit 410

The Millmate Operator Unit 410 provides communication with the control unit and is designed for panel mounting.

The operator unit(s) and control unit(s) are interconnected on a common network. This common network can be a separate network for measuring objects or it can be part of a local area network (LAN).

The communication on the network is in accordance with the IEEE 802.3 standard and uses TCP/IP protocol.

## Relay board PFVK 128

Fitted with four relays with one changeover function per relay.

## Insulation amplifier PXUB 201

The insulation amplifier can be used when improved electrical insulation is required. Selected voltage or current output.

01



02

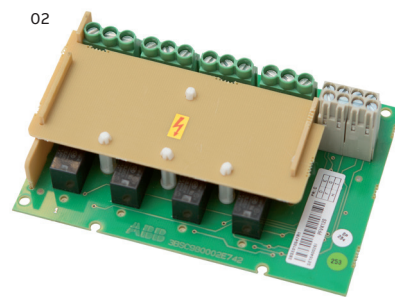

03



# Installation options

- 04 Wall cabinet
- 05 Matching unit PFVO 142/143
- 06 Floor cabinet

## Wall cabinet

A control unit can be installed in the dust- and hose-proof wall cabinet. The operator unit can be mounted on the inside of the door or through the door.

## Floor cabinet

The MNS floor cabinet can contain a combination of control units with Roll Force, Strip Tensiometer and Strip Scanner applications. They can be operated by one operator unit, optionally mounted through the door or inside the cabinet.

## Matching unit PFVO 142/143

Each PFVL 141 load cell requires one matching unit, which is interchangeable between load cells. It can be located up to 25 m away from the relevant load cell (depending on the nominal load).

## Matching device QIPZ 127

Each QGPR 104/102 load cell is delivered with an accompanying matching device. It should be located at a specific distance from the load cell.

04



05



06

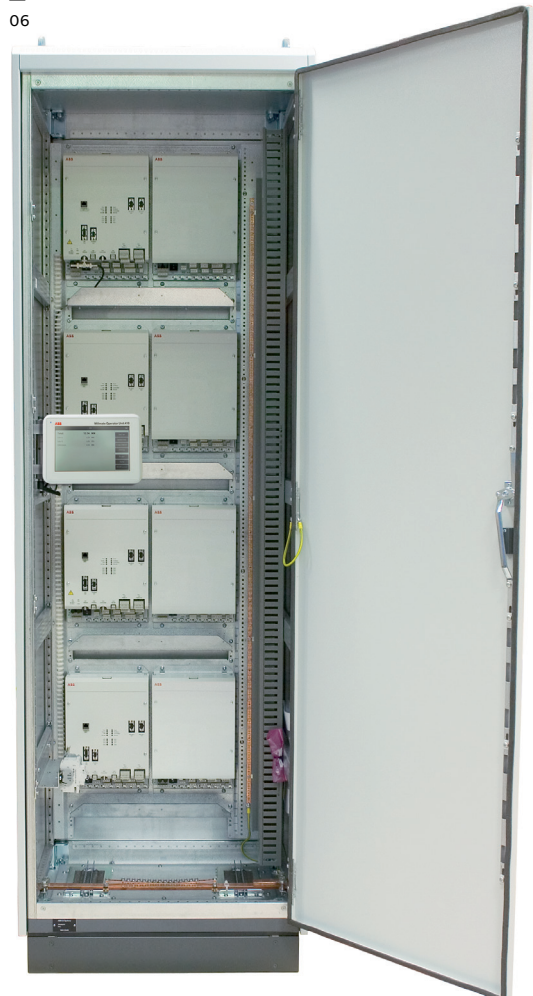



—  
**ABB AB**

**Measurement & Analytics**

Force Measurement

S-721 59 Västerås, Sweden

**[abb.com/rollforce](http://abb.com/rollforce)**

—  
We reserve the right to make technical changes or modify the contents of this document without prior notice. With regard to purchase orders, the agreed particulars shall prevail. ABB does not accept any responsibility whatsoever for potential errors or possible lack of information in this document.

We reserve all rights in this document and in the subject matter and illustrations contained therein. Any reproduction, disclosure to third parties or utilization of its contents – in whole or in parts – is forbidden without prior written consent of ABB.

© Copyright 2019 ABB.  
All rights reserved.