

## Technical Data

Original Instructions



**Allen-Bradley**

by ROCKWELL AUTOMATION

# PowerFlex 70 Adjustable Frequency AC Drive

Catalog Number 20A



Topic	Page
Summary of Changes	2
Product Overview	3
Catalog Number Explanation	6
Product Selection	7
Factory-installed Options	12
User Installed Options	14
Installation Power Wiring	22
Terminal Blocks	23
Cable Recommendations	28
Power Ratings and Branch Circuit Protection	30
Mounting	34
Approximate Dimensions and Weights	35
PowerFlex 70 Configured Drives	40
Standard Drive Certifications and Specifications	42
Derating Guidelines	47

---

## Summary of Changes

This publication contains the following new or updated information. This list includes substantive updates only and is not intended to reflect all changes.

<b>Topic</b>	<b>Page</b>
Added statements about conformal coat on the drive and enclosure	3, 6
Changed the Catalog Number Explanation section	6
Changed the explanations of where internal EMC filters are used	6, 13, 26
Added the Product Selection section	7...8
Changed the Isolation Transformers section	18

---

## Product Overview

PowerFlex® 70 drives are designed to worldwide standards providing out-of-the-box performance around the globe. Available ratings include these options:

- 0.5...25 Hp output at 240V AC input
- 0.5...50 Hp output at 480V AC input
- 0.5...50 Hp output at 600V AC input

The PowerFlex 70 drive can be used with a full featured LCD human interface module (HIM) that provides multilingual text for startup, metering, programming, and troubleshooting.

The PowerFlex 70 can be programmed for either volts per Hertz, sensorless vector, or vector control with FORCE™ Technology to cover a wide range of applications from fans to extruders.

Optional internal communication modules provide fast and efficient control and/or data exchange with host controllers over popular interfaces. These interfaces include: Connected Components Workbench™ software, DeviceNet®, Ethernet®, ControlNet®, serial communications, and other open control and communication networks. Computer tools such as DriveExplorer™ and DriveTools™ SP assist with programming, monitoring, and troubleshooting the PowerFlex 70.



DriveTools SP Software has been upgraded to Connected Components Workbench software. DriveTools support can be found at the Product Compatibility and Download Center [rok.auto/pcdc](http://rok.auto/pcdc), but is no longer available for sale.

## Flexible Packaging and Mounting

- **IP20, NEMA / UL Type 1** – For conventional mounting inside or outside a control cabinet. Conduit plate is vertically removable for easy installation and replacement without disturbing conduit.
- **IP66, NEMA / UL Type 4X/12** (indoor use) – For mounting directly in the production environment. Listed by UL to resist dust, dirt, other contaminants, and to survive high-pressure water spray. Also certified by NSF International to verify conformity with international food equipment standards.
- **Flange Type** – For mounting heatsink through back of an enclosure, thus removing a large portion of the heat inside a cabinet. The backside is rated IP66, NEMA / UL Type 4X/12 for both indoor and outdoor use.
- **Zero-Stacking™ Drive** - Drives can be mounted directly next to one another with no reduction of ambient temperature rating (50 °C [122 °F] for IP20, NEMA / UL Type 1, and Flange Mount; 40 °C [104 °F] for IP66, NEMA / UL Type 4X/12).
- **Conformal Coating** - The drive is coated in an insulator, or non-conducting substance, that helps protect it from moisture, fungus, dust, corrosion, abrasion, and other environmental stresses caused by highly polluted atmospheres. The coating improves product lifetime expectancy when exposure to corrosive environment is present. It helps maintain long-term surface insulation resistance, ensuring operational integrity of the assembly.

## Space Saving Hardware Features

- Integral electromagnetic compatibility (EMC) filtering provides a compact, all-in-one package solution for meeting EMC requirements, including CE in Europe.
- Integral dynamic brake transistor delivers a cost-effective means of switching regenerative energy without costly external chopper circuits.
- Internal dynamic brake resistor requires no extra panel space, and supplies a large amount of braking torque for short periods.
- Internal Communications allow you to integrate the drive into the manufacturing process. Status indicators for all internal communication options are visible on the cover for easy setup and monitoring of drive communications. You can easily manage information from shop floor to top floor and seamlessly integrate their complete system as they control, configure, and collect data.

## Easy to Use Human Interface Tools

The PowerFlex 7-Class AC drives provide common human interface tools that are familiar and easy to use. These tools include the LCD human interface modules and computer-based configuration tools.

The LCD HIMs provide these features and functions:

- Large and easy to read 7-line x 21-character backlit display
- Variety of languages (English, French, German, Italian, Spanish, Portuguese, Dutch)
- Alternate function keys for shortcuts to common tasks
- 'Calculator-like' number pad for fast and easy data entry (full numeric version only)
- Control keys for local start, stop, speed, and direction
- Remote versions for panel mount application

## Outstanding Control and Performance

- Volt/Hertz Control for simple Fan and Pump applications
- Vector Control with FORCE Technology provides outstanding torque and speed regulation, with or without encoder feedback.
- **Sensorless Vector Control** develops high torque over a wide speed range, and adapts to individual motor characteristics.

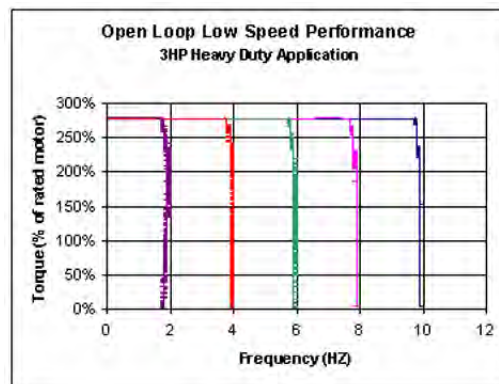
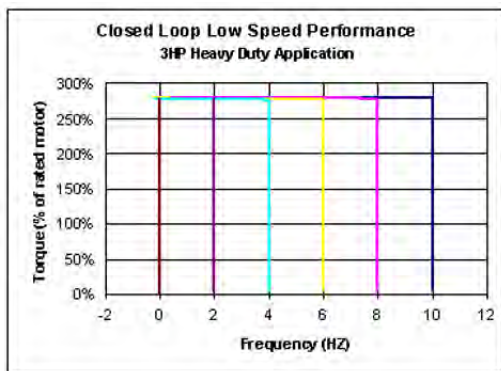

## Drives Features

- Fast acting **Current Limit** and **Bus Voltage Regulation** result in maximum acceleration and deceleration without tripping.
- **Flying Start** delivers smooth connection into rotating loads, regardless of commanded direction, without the need for any speed feedback device.
- **PI Control** can eliminate the need for a separate process loop controller.
- **Inertia Ride-Through** offers tripless operation during a prolonged power outage by using the rotating energy that is stored in high-inertia, low-friction loads.
- **User Sets**, allowing up to three complete sets of parameter data, can be individually loaded for different batch processes.
- **Slip compensation** delivers minimum of 0.5% open-loop speed regulation across a wide speed range, eliminating the need for speed feedback devices in some applications.
- **Safe Torque Off**, the first offering available within the DriveGuard® series of safety solutions, helps prevent a drive from delivering rotational energy to motors by integrating a safety circuit with the power switching signals of the drive. This solution meets EN ISO 13849-1, Category 3.
- **Droop Control** for load sharing applications.
- **Sleep/Wake Control** for analog control of start and stop.

## Unsurpassed Capability in Network Communications

PowerFlex drives are fully compatible with the wide variety of Allen-Bradley® DPI™ (drive peripheral interface) communication adapters, offering the following benefits.

Benefits and Description	Availability By Communication Adapter											
	BACnet	DeviceNet	ControlNet	EtherNet/IP	Dual-Port EtherNet/IP	RS-485 DFI	PROFIBUS DP	LonWorks	Modbus RTU	Modbus TCP	Metasys N2	Siemens PT/FLN
<b>Unconnected Messaging:</b> permits other network devices (for example, PanelView™) to communicate directly to a drive without routing the communication through the network scanner.		X	X	X	X							
<b>Adapter Routing:</b> plug personal computer into one drive and talk to other Allen-Bradley drives on same network, without being routed through network scanner.	X	X	X	X	X	X			X			
<b>Access all parameters:</b> provides access to 100% of parameters over the network.	X	X	X	X	X	X	X	X	X	X	X	X
<b>Autobaud:</b> makes initial connections less problematic.	X	X		X	X		X					
<b>Change of state:</b> significantly reduces network traffic by configuring control messages to be sent only upon customer defined states. Flexible configuration for each node (for example, reference must change by more than 5%).		X										
<b>Peer Control:</b> provides leader/follower type control between drives, where one or more follower drives (consumers) can run based on the status of a leader drive (producer). The leader drive can also significantly reduce network traffic.		X		X	X							
<b>Automatic Device Replacement (ADR):</b> saves significant time and effort when replacing a drive, by allowing the scanner to be configured to automatically detect a new drive and download the required parameter settings.		X										
<b>Flexible Fault Configuration:</b> adapters can be programmed to take fault-based actions such as ramp to stop, coast to stop, and hold last state, and send user configurable logic control and speed reference values. In addition, different actions can be taken based on whether the network experienced a serious problem (broken cable) versus a network idle condition (PLC set to 'Program.')	X	X	X	X	X	X	X	X	X	X	X	X

# Catalog Number Explanation

1...3 4 5...7 8 9 10 11 12 13 14 15 16  
 20A B 2P2 A 3 A Y Y N N C O  
 a b c d e f g h i j k l

Drive		
Code	Type	
20 A	PowerFlex 70	
Voltage Rating		
Code	Voltage	Ph.
B	240V AC	3 (6 pulse)
C	400V AC	3 (6 pulse)
D	480V AC	3 (6 pulse)
E	600V AC	3 (6 pulse)

PowerFlex 70 ND Rating				
208V, 60 Hz Input				
Code	208V amps	kW	Hp	Frame
2P2	2.5	0.37	0.5	A
4P2	4.8	0.75	1.0	
6P8	7.8	1.5	2.0	B
9P6	11	2.2	3.0	
015	17.5	4.0	5.0	C
022	25.3	5.5	7.5	
028	32.2	7.5	10	D
042	43	11	15	
054	56	15	20	E
070	78.2	18.5	25	

PowerFlex 70 ND Rating				
240V, 60 Hz Input				
Code	Amps	kW	Hp	Frame
2P2	2.2	0.37	0.5	A
4P2	4.2	0.75	1.0	
6P8	6.8	1.5	2.0	B
9P6	9.6	2.2	3.0	
015	15.3	4.0	5.0	C
022	22	5.5	7.5	
028	28	7.5	10	D
042	42	11	15	
054	54	15	20	E
070	70	18.5	25	

PowerFlex 70 ND Rating				
400V, 50 Hz Input				
Code	Amps	kW	Hp	Frame
1P3	1.3	0.37	0.5	A
2P1	2.1	0.75	1.0	
3P5	3.5	1.5	2.0	B
5P0	5.0	2.2	3.0	
8P7	8.7	4.0	5.0	C
011	11.5	5.5	7.5	
015	15.4	7.5	10	D
022	22	11	15	
030	30	15	20	E
037	37	18.5	25	
043	42	22	30	
060	60	30	40	
072	72	37	50	

PowerFlex 70 ND Rating				
480V, 60 Hz Input				
Code	Amps	kW	Hp	Frame
1P1	1.1	0.37	0.5	A
2P1	2.1	0.75	1.0	
3P4	3.4	1.5	2.0	B
5P0	5.0	2.2	3.0	
8P0	8.0	3.7	5.0	C
011	11	5.5	7.5	
014	14	7.5	10	D
022	22	11	15	
027	27	15	20	E
034	34	18.5	25	
040	40	22	30	
052	52	30	40	
065	65	37	50	

PowerFlex 70 ND Rating				
600V, 60 Hz Input <sup>(1)</sup>				
Code	Amps	kW	Hp	Frame
0P9	0.9	0.37	0.5	A
1P7	1.7	0.75	1.0	
2P7	2.7	1.5	2.0	B
3P9	3.9	2.2	3.0	
6P1	6.1	4.0	5.0	C
9P0	9.0	5.5	7.5	
011	11	7.5	10	D
017	17	11	15	
022	22	15	20	E
027	27	18.5	25	
032	32	22	30	
041	41	30	40	
052	52	37	50	

(1) 600V class drives are declared to meet the Low Voltage Directive. It is the responsibility of the user to determine compliance to the EMC Directive.

Enclosure	
Code	Enclosure <sup>(1)</sup>
A <sup>(2)</sup>	Panel Mount - IP 20, NEMA/UL Type 1
C <sup>(2)</sup>	Wall/Machine Mount = IP66, NEMA/UL Type 4X/12 for indoor use only
F	Flange Mount - Front Chassis = IP 20, NEMA/UL Type 1; Rear Heatsink = IP66, NEMA/UL Type 4X/12 for indoor use only
G	Wall/Machine Mount - IP54, NEMA/UL Type 12 <sup>(3)</sup>

- (1) All enclosures come with conformal coating standard.
- (2) IP20 and IP66 frame E drives are manufactured with a flange-like heat heatsink with mounting holes.
- (3) Only available on Frame E.

HIM	
Code	Interface Module
0	Blank Cover
3	Full Numeric LCD
5	Prog. Only LCD <sup>(1)</sup>

(1) Only available with NEMA 4X, enclosure C.

Documentation	
Code	Type
A	Manual
N	No manual

Brake IGBT	
Code	w/Brake
Y	Yes

Internal Brake Resistor	
Code	w/ Resistor
Y	Yes
N	No

Emission Class <sup>(1)</sup>	
Code	Rating
A	Filtered
N	Not Filtered

(1) For additional information, see the following table.

	Emission Class by Frame Current Rating (A...E) and Voltage				
	A <sup>(1)(2)</sup>	B <sup>(2)</sup>	C	D	E
240V	A or N	A or N	A	A	A
400V	A or N	A or N	A	A	A
480V	A or N	A or N	A	A	A
600V	N	N	N	N	A

- (1) If a filter is used with a Frame A current rating, the drive with internal filter is supplied in the B Frame to accommodate the additional size.
- (2) "A or N" indicates that filtering is optional.

Comm Slot	
Code	Network Type
C	ControlNet (Coax)
D	DeviceNet
E	EtherNet/IP
N	None

Control and I/O		
Code	Control	Safe Torque Off <sup>(1)</sup>
N <sup>(2)</sup>	Standard	N/A
C	Enhanced	No
G	Enhanced	Yes

- (1) Safe Torque Off is not available user-installed for 600V drives.
- (2) No longer available for sale.

Feedback <sup>(1)</sup>	
Code	Feedback
0	No Feedback - Enhanced Control
1	5V/12V Encoder w/Enhanced Control

(1) Drive is not CE EMC certified when the encoder interface option is installed.

## Product Selection

This section provides product selection information for the following:

- [Panel Mount - IP20, NEMA/UL Type 1, No HIM](#)
- [Wall/Machine Mount - IP66, NEMA/UL Type 4X/12 for Indoor Use with HIM on page 9](#)
- [Wall/Machine Mount - IP54, NEMA/UL Type 12, with HIM on page 10](#)
- [Flange Mount, Front Chassis = IP20, NEMA/UL Type 1, Heatsink = IP66, NEMA/UL Type 4X/12, No HIM on page 11](#)

### Panel Mount - IP20, NEMA/UL Type 1, No HIM

#### 200...240V AC, Three-phase Drives

240V AC Input					208V AC Input <sup>(1)</sup>						With Filter	Frame Size	
Output Amps			Normal Duty Hp	Heavy Duty Hp	Cat. No.	Output Amps			Normal Duty kW	Heavy Duty kW			Cat. No.
Cont.	60 s	3 s				Cont.	60 s	3 s					
2.2	2.4	3.3	0.5	0.33	20AB2P2A0AYNNNCO	2.5	2.7	3.7	0.37	0.25	20AB2P2A0AYNNNCO	No	A
					20AB2P2A0AYNANCO						20AB2P2A0AYNANCO	Yes	B
4.2	4.8	6.4	1	0.75	20AB4P2A0AYNNNCO	4.8	5.5	7.4	0.75	0.55	20AB4P2A0AYNNNCO	No	A
					20AB4P2A0AYNANCO						20AB4P2A0AYNANCO	Yes	
6.8	9	12	2	1.5	20AB6P8A0AYNNNCO	7.8	10.3	13.8	1.5	1.1	20AB6P8A0AYNNNCO	No	B
					20AB6P8A0AYNANCO						20AB6P8A0AYNANCO	Yes	
9.6	10.6	14.4	3	2	20AB9P6A0AYNNNCO	11	12.1	16.5	2.2	1.5	20AB9P6A0AYNNNCO	No	
					20AB9P6A0AYNANCO						20AB9P6A0AYNANCO		
15.3	17.4	23.2	5	3	20AB015A0AYNANCO	17.5	19.2	26.2	4	3	20AB015A0AYNANCO		C
22	24.2	33	7.5	5	20AB022A0AYNANCO	25.3	27.8	37.9	5.5	4	20AB022A0AYNANCO		D
28	33	44	10	7.5	20AB028A0AYNANCO	32.2	37.9	50.6	7.5	5.5	20AB028A0AYNANCO	Yes	
42	46.2	63	15	10	20AB042A0AYNANCO	43	55.5	74	11	7.5	20AB042A0AYNANCO		E
54	63	84	20	15	20AB054A0AYNANCO	62.1	72.4	96.6	15	11	20AB054A0AYNANCO		
70	81	108	25	20	20AB070A0AYNANCO	78.2	93.1	124	18.5	15	20AB070A0AYNANCO		

(1) Drive must be programmed to lower voltage to obtain the currents shown.

### 380...480V AC, Three-phase Drives

480V AC Input					400V AC Input						With Filter	Frame Size	
Output Amps			Normal Duty Hp	Heavy Duty Hp	Cat. No.	Output Amps			Normal Duty kW	Heavy Duty kW			Cat. No.
Cont.	60 s	3 s				Cont.	60 s	3 s					
1.1	1.2	1.6	0.5	0.33	20AD1P1A0AYNNNCO	1.3	1.4	1.9	0.37	0.25	20AC1P3A0AYNNNCO	No	A
					20AD1P1A0AYNANCO						20AC1P3A0AYNANCO	Yes	B
2.1	2.4	3.2	1	0.75	20AD2P1A0AYNNNCO	2.1	2.4	3.2	0.75	0.55	20AC2P1A0AYNNNCO	No	A
					20AD2P1A0AYNANCO						20AC2P1A0AYNANCO	Yes	B
3.4	4.5	6	2	1.5	20AD3P4A0AYNNNCO	3.5	4.5	6	1.5	1.1	20AC3P5A0AYNNNCO	No	A
					20AD3P4A0AYNANCO						20AC3P5A0AYNANCO	Yes	B
5	5.5	7.5	3	2	20AD5P0A0AYNNNCO	5	5.5	7.5	2.2	1.5	20AC5P0A0AYNNNCO	No	B
					20AD5P0A0AYNANCO						20AC5P0A0AYNANCO	Yes	
8	8.8	12	5	3	20AD8P0A0AYNNNCO	8.7	9.9	13.2	4	3	20AC8P7A0AYNNNCO	No	B
					20AD8P0A0AYNANCO						20AC8P7A0AYNANCO	Yes	
11	12.1	16.5	7.5	5	20AD011A0AYNANCO	11.5	13	17.4	5.5	4	20AC011A0AYNANCO		C
14	16.5	22	10	7.5	20AD014A0AYNANCO	15	17.2	23.1	7.5	5.5	20AC015A0AYNANCO		C
22	24.2	33	15	10	20AD022A0AYNANCO	22	24.2	33	11	7.5	20AC022A0AYNANCO		D
27	33	44	20	15	20AD027A0AYNANCO	30	33	45	15	11	20AC030A0AYNANCO		D
34	40.5	54	25	20	20AD034A0AYNANCO	37	45	60	18.5	15	20AC037A0AYNANCO		D
40	51	68	30	25	20AD040A0AYNANCO	43	56	74	22	18.5	20AC043A0AYNANCO		D
52	60	80	40	30	20AD052A0AYNANCO	60	66	90	30	22	20AC060A0AYNANCO		E
65	78	104	50	40	20AD065A0AYNANCO	72	90	120	37	30	20AC072A0AYNANCO		E

### 500...600V AC, Three-phase Drives

600V AC Input							
Output Amps			Normal Duty Hp	Heavy Duty Hp	Cat. No.	With Filter	Frame Size
Cont.	60 s	3 s					
0.9	1	1.4	0.5	0.33	20AE0P9A0AYNNNCO	No	A
1.7	1.9	2.6	1	0.75	20AE1P7A0AYNNNCO		
2.7	3.6	4.8	2	1	20AE2P7A0AYNNNCO		
3.9	4.3	5.8	3	1.5	20AE3P9A0AYNNNCO		B
6.1	6.7	9.1	5	3	20AE6P1A0AYNNNCO		
9	9.9	13.5	7.5	5	20AE9P0A0AYNNNCO		C
11	13.5	18	10	7.5	20AE011A0AYNNNCO		
17	18.7	25.5	15	10	20AE017A0AYNNNCO		
22	25.5	34	20	15	20AE022A0AYNNNCO		D
27	33	44	25	20	20AE027A0AYNNNCO		
32	40.5	54	30	25	20AE032A0AYNNNCO		
41	48	64	40	30	20AE041A0AYNANCO		
52	61.5	82	50	40	20AE052A0AYNANCO		E

# Wall/Machine Mount - IP66, NEMA/UL Type 4X/12 for Indoor Use with HIM

## 200...240V AC, Three-phase Drives

240V AC Input					208V AC Input <sup>(1)</sup>					With Filter	Frame Size				
Output Amps			Normal Duty Hp	Heavy Duty Hp	Cat. No.	Output Amps			Normal Duty kW			Heavy Duty kW	Cat. No.		
Cont.	60 s	3 s				Cont.	60 s	3 s							
2.2	2.4	3.3	0.5	0.33	20AB2P2C3AYNNNCO	2.5	2.7	3.7	0.37	0.25	20AB2P2C3AYNNNCO	No	B		
					20AB2P2C3AYNANCO						20AB2P2C3AYNANCO	Yes			
4.2	4.8	6.4	1	0.75	20AB4P2C3AYNNNCO	4.8	5.5	7.4	0.75	0.55	20AB4P2C3AYNNNCO	No		D	
					20AB4P2C3AYNANCO						20AB4P2C3AYNANCO	Yes			
6.8	9	12	2	1.5	20AB6P8C3AYNNNCO	7.8	10.3	13.8	1.5	1.1	20AB6P8C3AYNNNCO	No		E	
					20AB6P8C3AYNANCO						20AB6P8C3AYNANCO	Yes			
9.6	10.6	14.4	3	2	20AB9P6C3AYNNNCO	11	12.1	16.5	2.2	1.5	20AB9P6C3AYNNNCO	No		D	
					20AB9P6C3AYNANCO						20AB9P6C3AYNANCO	Yes			
15.3	17.4	23.2	5	3	20AB015C3AYNANCO	17.5	19.2	26.2	4	3	20AB015C3AYNANCO	Yes			E
22	24.2	33	7.5	5	20AB022C3AYNANCO	25.3	27.8	37.9	5.5	4	20AB022C3AYNANCO				
28	33	44	10	7.5	20AB028C3AYNANCO	32.2	37.9	50.6	7.5	5.5	20AB028C3AYNANCO				
42	46.2	63	15	10	20AB042C3AYNANCO	43	55.5	74	11	7.5	20AB042C3AYNANCO				
54	63	84	20	15	20AB054C3AYNANCO	62.1	72.4	96.6	15	11	20AB054C3AYNANCO				
70	81	108	25	20	20AB070C3AYNANCO	78.2	93.1	124	18.5	15	20AB070C3AYNANCO				

(1) The drive must be programmed to lower voltage to obtain the currents shown.

## 380...480V AC, Three-phase Drives

480V AC Input					400V AC Input					With Filter	Frame Size				
Output Amps			Normal Duty Hp	Heavy Duty Hp	Cat. No.	Output Amps			Normal Duty kW			Heavy Duty kW	Cat. No.		
Cont.	60 s	3 s				Cont.	60 s	3 s							
1.1	1.2	1.6	0.5	0.33	20AD1P1C3AYNNNCO	1.3	1.4	1.9	0.37	0.25	20AC1P3C3AYNNNCO	No	B		
					20AD1P1C3AYNANCO						20AC1P3C3AYNANCO	Yes			
2.1	2.4	3.2	1	0.75	20AD2P1C3AYNNNCO	2.1	2.4	3.2	0.75	0.55	20AC2P1C3AYNNNCO	No		D	
					20AD2P1C3AYNANCO						20AC2P1C3AYNANCO	Yes			
3.4	4.5	6	2	1.5	20AD3P4C3AYNNNCO	3.5	4.5	6	1.5	1.1	20AC3P5C3AYNNNCO	No		E	
					20AD3P4C3AYNANCO						20AC3P5C3AYNANCO	Yes			
5	5.5	7.5	3	2	20AD5P0C3AYNNNCO	5	5.5	7.5	2.2	1.5	20AC5P0C3AYNNNCO	No		D	
					20AD5P0C3AYNANCO						20AC5P0C3AYNANCO	Yes			
8	8.8	12	5	3	20AD8P0C3AYNNNCO	8.7	9.9	13.2	4	3	20AC8P7C3AYNNNCO	No			E
					20AD8P0C3AYNANCO						20AC8P7C3AYNANCO	Yes			
11	12.1	16.5	7.5	5	20AD011C3AYNANCO	11.5	13	17.4	5.5	4	20AC011C3AYNANCO	Yes	E		
14	16.5	22	10	7.5	20AD014C3AYNANCO	15	17.2	23.1	7.5	5.5	20AC015C3AYNANCO				
22	24.2	33	15	10	20AD022C3AYNANCO	22	24.2	33	11	7.5	20AC022C3AYNANCO				
27	33	44	20	15	20AD027C3AYNANCO	30	33	45	15	11	20AC030C3AYNANCO				
34	40.5	54	25	20	20AD034C3AYNANCO	37	45	60	18.5	15	20AC037C3AYNANCO				
40	51	68	30	25	20AD040C3AYNANCO	43	56	74	22	18.5	20AC043C3AYNANCO				
52	60	80	40	30	20AD052C3AYNANCO	60	66	90	30	22	20AC060C3AYNANCO				
65	78	104	50	40	20AD065C3AYNANCO	72	90	120	37	30	20AC072C3AYNANCO				

## 500...600V AC, Three-phase Drives

600V AC Input						With Filter	Frame Size
Output Amps			Normal Duty Hp	Heavy Duty Hp	Cat. No.		
Cont.	60 s	3 s					
0.9	1	1.4	0.5	0.33	20AEO9C3AYNNNCO	No	B
1.7	1.9	2.6	1	0.75	20AE1P7C3AYNNNCO		
2.7	3.6	4.8	2	1	20AE2P7C3AYNNNCO		
3.9	4.3	5.8	3	1.5	20AE3P9C3AYNNNCO		
6.1	6.7	9.1	5	3	20AE6P1C3AYNNNCO		
9	9.9	13.5	7.5	5	20AE9P0C3AYNNNCO		D
11	13.5	18	10	7.5	20AE011C3AYNNNCO		
17	18.7	25.5	15	10	20AE017C3AYNNNCO		
22	25.5	34	20	15	20AE022C3AYNNNCO		
27	33	44	25	20	20AE027C3AYNNNCO		
32	40.5	54	30	25	20AE032C3AYNNNCO	E	
41	48	64	40	30	20AE041C3AYNANCO		
52	61.5	82	50	40	20AE052C3AYNANCO		

## Wall/Machine Mount - IP54, NEMA/UL Type 12, with HIM

### 200...240V AC, Three-phase Drives

240V AC Input					208V AC Input <sup>(1)</sup>					Cat. No.	With Filter	Frame Size
Output Amps			Normal Duty Hp	Heavy Duty Hp	Output Amps			Normal Duty kW	Heavy Duty kW			
Cont.	60 s	3 s			Cont.	60 s	3 s					
54	63	84	20	15	62.1	72.4	96.6	15	11	20AB054G3AYNANCO	Yes	E
70	81	108	25	20	78.2	93.1	124	18.5	15	20AB070G3AYNANCO		

(1) Drive must be programmed to lower voltage to obtain the currents shown.

### 380...480V AC, Three-phase Drives

480V AC Input						400V AC Input						With Filter	Frame Size
Output Amps			Normal Duty Hp	Heavy Duty Hp	Cat. No.	Output Amps			Normal Duty kW	Heavy Duty kW	Cat. No.		
Cont.	60 s	3 s				Cont.	60 s	3 s					
52	60	80	40	30	20AD052G3AYNANCO	60	66	90	30	22	20AC060G3AYNANCO	Yes	E
65	78	104	50	40	20AD065G3AYNANCO	72	90	120	37	30	20AC072G3AYNANCO		

### 500...600V AC, Three-phase Drives

600V AC Input						With Filter	Frame Size
Output Amps			Normal Duty Hp	Heavy Duty Hp	Cat. No.		
Cont.	60 s	3 s					
41	48	64	40	30	20AE041G3AYNANCO	Yes	E
52	61.5	82	50	40	20AE052G3AYNANCO		

# Flange Mount, Front Chassis = IP20, NEMA/UL Type 1, Heatsink = IP66, NEMA/UL Type 4X/12, No HIM

## 200...240V AC, Three-phase Drives

240V AC Input						208V AC Input <sup>(1)</sup>						With Filter	Frame Size
Output Amps			Normal Duty Hp	Heavy Duty Hp	Cat. No.	Output Amps			Normal Duty kW	Heavy Duty kW	Cat. No.		
Cont.	60 s	3 s				Cont.	60 s	3 s					
2.2	2.4	3.3	0.5	0.33	20AB2P2FOAYNNNCO	2.5	2.7	3.7	0.37	0.25	20AB2P2FOAYNNNCO	No	A
					20AB2P2FOAYNANCO						20AB2P2FOAYNANCO	Yes	B
4.2	4.8	6.4	1	0.75	20AB4P2FOAYNNNCO	4.8	5.5	7.4	0.75	0.55	20AB4P2FOAYNNNCO	No	A
					20AB4P2FOAYNANCO						20AB4P2FOAYNANCO	Yes	B
6.8	9	12	2	1.5	20AB6P8FOAYNNNCO	7.8	10.3	13.8	1.5	1.1	20AB6P8FOAYNNNCO	No	
					20AB6P8FOAYNANCO						20AB6P8FOAYNANCO	Yes	
9.6	10.6	14.4	3	2	20AB9P6FOAYNNNCO	11	12.1	16.5	2.2	1.5	20AB9P6FOAYNNNCO	No	C
					20AB9P6FOAYNANCO						20AB9P6FOAYNANCO	Yes	
15.3	17.4	23.2	5	3	20AB015FOAYNANCO	17.5	19.2	26.2	4	3	20AB015FOAYNANCO		Yes
22	24.2	33	7.5	5	20AB022FOAYNANCO	25.3	27.8	37.9	5.5	4	20AB022FOAYNANCO		
28	33	44	10	7.5	20AB028FOAYNANCO	32.2	37.9	50.6	7.5	5.5	20AB028FOAYNANCO	Yes	E
42	46.2	63	15	10	20AB042FOAYNANCO	43	55.5	74	11	7.5	20AB042FOAYNANCO		
54	63	84	20	15	20AB054FOAYNANCO	62.1	72.4	96.6	15	11	20AB054FOAYNANCO		
70	81	108	25	20	20AB070FOAYNANCO	78.2	93.1	124	18.5	15	20AB070FOAYNANCO		

(1) Drive must be programmed to lower voltage to obtain the currents shown.

## 380...480V AC, Three-phase Drives

480V AC Input						400V AC Input						With Filter	Frame Size
Output Amps			Normal Duty Hp	Heavy Duty Hp	Cat. No.	Output Amps			Normal Duty kW	Heavy Duty kW	Cat. No.		
Cont.	60 s	3 s				Cont.	60 s	3 s					
1.1	1.2	1.6	0.5	0.33	20AD1P1FOAYNNNCO	1.3	1.4	1.9	0.37	0.25	20AC1P3FOAYNNNCO	No	A
					20AD1P1FOAYNANCO						20AC1P3FOAYNANCO	Yes	B
2.1	2.4	3.2	1	0.75	20AD2P1FOAYNNNCO	2.1	2.4	3.2	0.75	0.55	20AC2P1FOAYNNNCO	No	A
					20AD2P1FOAYNANCO						20AC2P1FOAYNANCO	Yes	B
3.4	4.5	6	2	1.5	20AD3P4FOAYNNNCO	3.5	4.5	6	1.5	1.1	20AC3P5FOAYNNNCO	No	A
					20AD3P4FOAYNANCO						20AC3P5FOAYNANCO	Yes	B
5	5.5	7.5	3	2	20AD5P0FOAYNNNCO	5	5.5	7.5	2.2	1.5	20AC5P0FOAYNNNCO	No	
					20AD5P0FOAYNANCO						20AC5P0FOAYNANCO	Yes	
8	8.8	12	5	3	20AD8P0FOAYNNNCO	8.7	9.9	13.2	4	3	20AC8P7FOAYNNNCO	No	C
					20AD8P0FOAYNANCO						20AC8P7FOAYNANCO	Yes	
11	12.1	16.5	7.5	5	20AD011FOAYNANCO	11.5	13	17.4	5.5	4	20AC011FOAYNANCO		Yes
14	16.5	22	10	7.5	20AD014FOAYNANCO	15	17.2	23.1	7.5	5.5	20AC015FOAYNANCO		
22	24.2	33	15	10	20AD022FOAYNANCO	22	24.2	33	11	7.5	20AC022FOAYNANCO	Yes	E
27	33	44	20	15	20AD027FOAYNANCO	30	33	45	15	11	20AC030FOAYNANCO		
34	40.5	54	25	20	20AD034FOAYNANCO	37	45	60	18.5	15	20AC037FOAYNANCO		
40	51	68	30	25	20AD040FOAYNANCO	43	56	74	22	18.5	20AC043FOAYNANCO		
52	60	80	40	30	20AD052FOAYNANCO	60	66	90	30	22	20AC060FOAYNANCO		
65	78	104	50	40	20AD065FOAYNANCO	72	90	120	37	30	20AC072FOAYNANCO		

## 500...600V AC, Three-phase Drives

600V AC Input						With Filter	Frame Size
Output Amps			Normal Duty Hp	Heavy Duty Hp	Cat. No.		
Cont.	60 s	3 s					
0.9	1	1.4	0.5	0.33	20AE0P9FOAYNNNCO	No	A
1.7	1.9	2.6	1	0.75	20AE1P7FOAYNNNCO		
2.7	3.6	4.8	2	1	20AE2P7FOAYNNNCO		
3.9	4.3	5.8	3	1.5	20AE3P9FOAYNNNCO		B
6.1	6.7	9.1	5	3	20AE6P1FOAYNNNCO		
9	9.9	13.5	7.5	5	20AE9P0FOAYNNNCO		C
11	13.5	18	10	7.5	20AE011FOAYNNNCO		
17	18.7	25.5	15	10	20AE017FOAYNNNCO		D
22	25.5	34	20	15	20AE022FOAYNNNCO		
27	33	44	25	20	20AE027FOAYNNNCO		
32	40.5	54	30	25	20AE032FOAYNNNCO		
41	48	64	40	30	20AE041FOAYNANCO		E
52	61.5	82	50	40	20AE052FOAYNANCO		

## Factory-installed Options

This section provides information about optional components that are installed at the factory.

## Human Interface and Wireless Interface Modules *(Position)*

### IP20, NEMA/UL Type 1 and Flange Type Drives



Cat. Code: 0  
No HIM (Blank Plate)



Cat. Code: 3  
LCD Display, Full  
Numeric Keypad

### IP66, NEMA/UL Type 4X/12 Drives



Cat. Code: 5  
LCD Display,  
Programmer Only



Cat. Code: 0  
No HIM (Blank)



Cat. Code: 3  
LCD Display, Full  
Numeric Keypad

## Internal Dynamic Brake Resistors

Internal Dynamic Brake Resistors			
Drive Input Voltage	Brake Resistance	Frame	Cat. Code <i>(Position h)</i>
	W		
200...240V AC	62	A	Y
		B	Y
		C	Y
	22	D	Y
		E	Not Available
380...480V AC	115	A	Y
		B	Y
		C	Y
	62	D	Y
		E	Not Available
600V AC	115	A	Y
		B	Y
		C	Y
	—	D and E	Not Available

These resistors have a limited duty cycle. See the PowerFlex Dynamic Braking Selection Guide to determine if an internal resistor is sufficient. An external resistor may be required.

## Internal EMC Filter

Internal EMC Filter			
Drive Voltage	CE Filter	Frame <sup>(1)</sup>	Cat. Code <i>(Position i)</i>
200...240V AC	Optional	B	A
	Standard	C	
	Standard	D	
380...480V AC	Optional	B	A
	Standard	C	
	Standard	D	
	Standard	E	
600V AC <sup>(2)</sup>	Standard	E	—

- (1) Internal CE filters are not available inside of the compact A Frame size. If an A Frame current rating is ordered with an internal filter option, the drive with internal CE filter is supplied in the B Frame to accommodate the additional size.  
 (2) 600V AC Frames A...D available only without filter.

## Internal Communication Adapters

Internal Communication Adapters	Cat. Code <i>(Position j)</i>
ControlNet Communication Adapter (Coax)	C
DeviceNet Communication Adapter	D
EtherNet/IP Communication Adapter	E
None	N

## Control Options

Control Options	Cat. Code <i>(Position k)</i>
Enhanced Control without DriveGuard Safe Torque Off	C
Enhanced Control with DriveGuard Safe Torque Off	G

## Feedback Options

Feedback Options	Cat. Code <i>(Position k)</i>
None	0
5V/12V Encoder <sup>(1)</sup>	1

- (1) Drive is not CE EMC certified when the encoder interface option is installed.

## Documentation

Documentation	Cat. Code <i>(Position l)</i>
Manual	A
No manual	N

# User Installed Options

This section provides information about optional components that you can install.

## Human Interface and Wireless Interface Modules



No HIM (Blank Plate)  
20-HIM-A0



LCD Display, Full  
Numeric Keypad  
20-HIM-A3



LCD Display,  
Programmer Only  
20-HIM-A5



Enhanced LCD Display,  
Full Numeric Keypad  
20-HIM-A6



Remote (Panel Mount)  
LCD Display, Full  
Numeric Keypad  
20-HIM-C3S



Remote (Panel Mount)  
LCD Display,  
Programmer Only  
20-HIM-C5S



Enhanced LCD Display,  
Full Numeric Keypad  
20-HIM-C6S

Description	Handheld/Local (Drive Mount)	Remote (Panel Mount) IP66, NEMA/UL Type 4x/12 *
	Cat. No.	Cat. No.
No HIM (Blank Plate)	20-HIM-A0	-
LCD Display, Full Numeric Keypad	20-HIM-A3	20-HIM-C3S ‡
LCD Display, Programmer Only	20-HIM-A5	20-HIM-C5S ‡
Enhanced LCD Display, Full Numeric Keypad	20-HIM-A6	20-HIM-C6S

\* For indoor use only.

‡ Includes a 1202-C30 interface cable, 3 m (9.8 ft), for connection to drive.

## Human Interface Module Accessories

Description	Cat. No.
Bezel Kit for LCD HIMs, NEMA/UL Type 1 ‡	20-HIM-B1
PowerFlex HIM Interface Cable, 1 m (39 in)	20-HIM-H10
Cable Kit (Male-Female) >	
0.33 Meters (1.1 Feet)	1202-H03
1 Meter (3.3 Feet)	1202-H10
3 Meter (9.8 Feet)	1202-H30
9 Meter (29.5 Feet)	1202-H90
Comm Option Cable Kit	
0.33 Meters (1.1 Feet)	1202-C03
1 Meter (3.3 Feet)	1202-C10
3 Meter (9.8 Feet)	1202-C30
9 Meter (29.5 Feet)	1202-C90
DPI Cable Kit with Connectors, Tools and 100 m (328 ft.) Cable	1202-CBL-KIT-100M
DPI Cable Connector Kit	1202-TB-KIT-SET
DPI/SCANport™ One to Two Port Splitter Cable	1203-S03

‡ Includes a 1202-C30 interface cable (3 meters) for connection to drive.

Required only when HIM is used as handheld or remote.

> Required in addition to 20-HIM-H10 for distances up to a total maximum of 10 Meters (32.8 Feet).

# Dynamic Brake Resistors

This section includes [Small Duty Internal Dynamic Brake Resistors](#), [Internal Dynamic Brake Resistor Kits](#), [Medium Duty External Dynamic Brake Resistors on page 16](#), and [External Dynamic Brake Resistor Kits on page 16](#).

## Small Duty Internal Dynamic Brake Resistors

Limited duty resistors mount directly to the back surface of the drive and require no extra panel space. Internal resistors are non-destructive and do not require a resistor overheat external safety circuit.

PowerFlex 70 AC Drive			Small Duty Internal DB Resistor								
Normal Duty* kW (Hp)	Heavy Duty* kW (Hp)	Min DB Res Ohms ±10%	Part Number	Resistance * Ohms ±5%	Continuous Power kW	Max Energy kJ	Max Braking Torque % of ND Motor	Application Type 1		Application Type 2	
								Braking Torque % of ND Motor	Duty Cycle	Braking Torque % of ND Motor	Duty Cycle
200...240 Volt AC Input Drives											
0.37 (0.5)	0.25 (0.33)	33	20AB-DB1-A	62	0.048	8.3	307%	100%	25.9%	150%	17.3%
0.75 (1.0)	0.55 (0.75)	33	20AB-DB1-A	62	0.048	7.3	300%	100%	12.8%	150%	8.5%
1.5 (2.0)	1.1 (1.5)	33	20AB-DB1-B	62	0.028	0.8	160%	100%	3.7%	150%	2.5%
2.2 (3.0)	1.5 (2.0)	33	20AB-DB1-B	62	0.028	0.8	109%	100%	2.5%	109%	2.3%
4.0 (5.0)	3.0 (3.0)	30	20AB-DB1-C	62	0.040	0.8	60%	60%	3.3%	N/A	N/A
5.5 (7.5)	4.0 (5.0)	21	20AB-DB1-D	22	0.036	0.9	117%	100%	1.3%	117%	1.1%
7.5 (10)	5.5 (7.5)	21	20AB-DB1-D	22	0.036	0.9	86%	86%	1.1%	N/A	N/A
400...480 Volt AC Input Drives											
0.37 (0.5)	0.25 (0.33)	68	20AD-DB1-A	115	0.048	8.3	320%	100%	25.9%	150%	17.3%
0.75 (1.0)	0.55 (0.75)	68	20AD-DB1-A	115	0.048	9.0	259%	100%	12.8%	150%	8.5%
1.5 (2.0)	1.1 (1.5)	68	20AD-DB1-A	115	0.048	2.4	243%	100%	6.4%	150%	4.3%
2.2 (3.0)	1.5 (2.0)	68	20AD-DB1-B	115	0.028	0.9	206%	100%	2.5%	150%	1.7%
4.0 (5.0)	3.0 (3.0)	68	20AD-DB1-B	115	0.028	0.9	129%	100%	1.4%	129%	1.1%
5.5 (7.5)	4.0 (5.0)	74	20AD-DB1-C	115	0.04	0.9	94%	94%	1.5%	N/A	N/A
7.5 (10)	5.5 (7.5)	74	20AD-DB1-C	115	0.04	0.9	69%	69%	1.5%	N/A	N/A
11 (15)	7.5 (10)	44	20AD-DB1-D	62	0.036	0.8	87%	87%	0.8%	N/A	N/A
15 (20)	11 (15)	31	20AD-DB1-D	62	0.036	0.8	64%	64%	0.8%	N/A	N/A
500...600 Volt AC Input Drives											
0.37 (0.5)	0.25 (0.33)	117	20AD-DB1-A	115	0.048	8.3	287%	100%	25.9%	150%	17.3%
0.75 (1.0)	0.55 (0.75)	117	20AD-DB1-A	115	0.048	9.0	263%	100%	12.8%	150%	8.5%
1.5 (2.0)	1.1 (1.5)	117	20AD-DB1-A	115	0.048	2.4	243%	100%	6.4%	150%	4.3%
2.2 (3.0)	1.5 (2.0)	117	20AD-DB1-B	115	0.028	0.9	202%	100%	2.5%	150%	1.7%
4.0 (5.0)	3.0 (3.0)	80	20AD-DB1-B	115	0.028	0.9	193%	100%	1.4%	150%	0.9%
5.5 (7.5)	4.0 (5.0)	80	20AD-DB1-C	115	0.04	0.9	147%	100%	1.5%	147%	1.0%
7.5 (10)	5.5 (7.5)	80	20AD-DB1-C	115	0.04	0.9	108%	100%	1.1%	108%	1.0%
11 (15)	7.5 (10)	48	N/A	N/A	N/A	N/A	N/A	N/A	N/A	N/A	N/A
15 (20)	11 (15)	48	N/A	N/A	N/A	N/A	N/A	N/A	N/A	N/A	N/A

\* Duty cycle listed is based on full speed to zero speed deceleration. For constant regen at full speed, duty cycle capability is half of what is listed. Application Type 1 represents maximum capability up to 100% braking torque where possible. Application Type 2 represents more than 100% braking torque where possible, up to a maximum of 150%.

\* Always check resistor ohms against minimum resistance for drive being used.

## Internal Dynamic Brake Resistor Kits

Drive Input Voltage	Brake Resistance	Frame	Cat. No.
	Ω		
200...240V AC	62	A	20AB-DB1-A
		B	20AB-DB1-B
		C	20AB-DB1-C
		D	20AB-DB1-D
		E	Not Available
380...480V AC	115	A	20AD-DB1-A
		B	20AD-DB1-B
		C	20AD-DB1-C
		D	20AD-DB1-D
		E	Not Available
600V AC	115	A	20AD-DB1-A
		B	20AD-DB1-B
		C	20AD-DB1-C
		D and E	Not Available

These resistors have a limited duty cycle. See the PowerFlex Dynamic Braking Resistor Calculator Application Technique, publication [PELEX-AT001](#), to determine if an internal resistor is sufficient. An external resistor may be required.

## Medium Duty External Dynamic Brake Resistors

These resistors provide a larger duty cycle capability than the internal type. Includes an internal thermal switch for use in external safety circuit.

PowerFlex 70 AC Drive			Medium Duty External DB Resistor									
Normal Duty* kW (Hp)	Heavy Duty* kW (Hp)	Min DB Res Ohms ±10%	Part Number	Resistance* Ohms ±5%	Continuous Power kW	Max Energy kJ	Max Braking Torque % of ND Motor	Application Type 1		Application Type 2		
								Braking Torque % of ND Motor	Duty Cycle	Braking Torque % of ND Motor	Duty Cycle	
200...240 Volt ac Input Drives												
0.37 (0.5)	0.25 (0.33)	33	AK-R2-091P500	91	0.086	17	293%	100%	46%	150%	31%	
0.75 (1.0)	0.55 (0.75)	33	AK-R2-091P500	91	0.086	17	218%	100%	23%	150%	15%	
1.5 (2.0)	1.1 (1.5)	33	AK-R2-091P500	91	0.086	17	109%	100%	11%	109%	11%	
2.2 (3.0)	1.5 (2.0)	33	AK-R2-047P500	47	0.166	33	144%	100%	15%	144%	11%	
4.0 (5.0)	3.0 (3.0)	30	AK-R2-047P500	47	0.166	33	79%	79%	11%	N/A	N/A	
5.5 (7.5)	4.0 (5.0)	23	AK-R2-030P1K2	30	0.26	52	90%	90%	10%	N/A	N/A	
7.5 (10)	5.5 (7.5)	23	AK-R2-030P1K2	30	0.26	52	66%	66%	10%	N/A	N/A	
400...480 Volt ac Input Drives												
0.37 (0.5)	0.25 (0.33)	68	AK-R2-360P500	360	0.086	17	305%	100%	47%	150%	31%	
0.75 (1.0)	0.55 (0.75)	68	AK-R2-360P500	360	0.086	17	220%	100%	23%	150%	15%	
1.5 (2.0)	1.1 (1.5)	68	AK-R2-360P500	360	0.086	17	110%	100%	12%	110%	11%	
2.2 (3.0)	1.5 (2.0)	68	AK-R2-120P1K2	120	0.26	52	197%	100%	24%	150%	16%	
4.0 (5.0)	3.0 (3.0)	68	AK-R2-120P1K2	120	0.26	52	124%	100%	13%	124%	10%	
5.5 (7.5)	4.0 (5.0)	74	AK-R2-120P1K2	120	0.26	52	90%	90%	10%	N/A	N/A	
7.5 (10)	5.5 (7.5)	74	AK-R2-120P1K2	120	0.26	52	66%	66%	10%	N/A	N/A	
11 (15) ‡	7.5 (10) ‡	44	‡	60	0.52	104	90%	90%	10%	N/A	N/A	
15 (20) ‡	11 (15) ‡	31	‡	60	0.52	104	66%	66%	10%	N/A	N/A	
500...600 Volt ac Input Drives												
0.37 (0.5)	0.25 (0.33)	117	AK-R2-360P500	360	0.086	17	274%	100%	46%	150%	31%	
0.75 (1.0)	0.55 (0.75)	117	AK-R2-360P500	360	0.086	17	251%	100%	23%	150%	15%	
1.5 (2.0)	1.1 (1.5)	117	AK-R2-360P500	360	0.086	17	172%	100%	11%	150%	8%	
2.2 (3.0)	1.5 (2.0)	117	AK-R2-120P1K2	120	0.26	52	193%	100%	24%	150%	16%	
4.0 (5.0)	3.0 (3.0)	80	AK-R2-120P1K2	120	0.26	52	185%	100%	13%	150%	9%	
5.5 (7.5)	4.0 (5.0)	80	AK-R2-120P1K2	120	0.26	52	141%	100%	9%	141%	7%	
7.5 (10)	5.5 (7.5)	80	AK-R2-120P1K2	120	0.26	52	103%	100%	7%	103%	7%	
11 (15) ‡	7.5 (10) ‡	48	‡	60	0.52	104	141%	100%	9%	141%	7%	
15 (20) ‡	11 (15) ‡	48	‡	60	0.52	104	103%	100%	7%	103%	7%	

\* Duty cycle listed is based on full speed to zero speed deceleration. For constant regen at full speed, duty cycle capability is half of what is listed. Application Type 1 represents maximum capability up to 100% braking torque where possible. Application Type 2 represents more than 100% braking torque where possible, up to a maximum of 150%.

‡ Always check resistor ohms against minimum resistance for drive being used.

‡ For 11 and 15 kW (15 and 20 Hp) applications, use two 7.5 kW (10 Hp) size resistors wired in parallel.

## External Dynamic Brake Resistor Kits

Drive Input Voltage	Brake Resistance	Continuous Power	Cat. No.
	Ω	W	
200...240V AC	30	260	AK-R2-030P1K2
	47	166	AK-R2-047P500
	91	86	AK-R2-091P500
480...600V AC	120	260	AK-R2-120P1K2
	360	86	AK-R2-360P500

## Communication Options

The sections that follow describe the communication options that are available.

### Communication Option Kits

Description	Cat. No.
BACnet® MS/TP RS-485 Communication Adapter	20-COMM-B
ControlNet Communication Adapter (Coax)	20-COMM-C
DeviceNet Communication Adapter	20-COMM-D
EtherNet/IP Communication Adapter	20-COMM-E
Dual-port EtherNet/IP Communication Adapter	20-COMM-ER
HVAC Communication Adapter	20-COMM-H
CANopen® Communication Adapter	20-COMM-K
LonWorks® Communication Adapter	20-COMM-L
Modbus/TCP Communication Adapter	20-COMM-M
PROFIBUS™ DP Communication Adapter	20-COMM-P
ControlNet Communication Adapter	20-COMM-Q
RS-485 DFI Communication Adapter	20-COMM-S
External Communications Kit Power Supply	20-XCOMM-AC-PS1
DPI External Communications Kit	20-XCOMM-DC-BASE
External DPI I/O Option Board <sup>(1)</sup>	20-XCOMM-IO-OPT1
Compact I/O™ Module (3 Channel)	1769-SM1
Serial Null Modem Adapter	1203-SNM
Smart Self-powered Serial Converter (RS-232) includes 1203-SFC and 1202-C10 cables	1203-SSS
Universal Serial Bus (USB) Converter includes 2 m (6.5 ft) USB, 20-HIM-H10, and 22-HIM-H10 cables	1203-USB

(1) For use only with DPI External Communications Kits 20-XCOMM-DC-BASE.

### Other Options

Description	Cat. No.
DriveGuard Safe Torque Off Board	20A-DG01
5V/12V Encoder <sup>(1)</sup>	20A-ENC-1
115V AC Interface	AK-M9-115VAC-1
Frame E Flange Gasket	AK-M9-GASKET1-E4
Service Connection Board <sup>(2)</sup>	SK-M9-SCB1

(1) Drive is not CE EMC certified when the encoder interface option is installed.

(2) Provides temporary DPI/HIM connection for NEMA/UL Type 1 and Flange drives with cover removed.

### Terminators

Description <sup>(1)</sup>	Cat. No.
for use with 3.7 kW (5 HP) and below drives	1204-TFA1
for use with 1.5 kW (2 Hp) and up drives	1204-TFB2

(1) For selection information, see Wiring and Grounding Guidelines for Pulse-width Modulated (PWM) AC Drives, publication [DRIVES-IN001](#), Appendix A.

### Reflected Wave Reduction Modules

Description <sup>(1)</sup>	Cat. No.
17 A with Common Mode Choke	1204-RWC-17-A
9 A without Choke, Book Mount <sup>(2)</sup>	1204-RWR2-09-B
9 A, without Choke, Stack Mount <sup>(2)</sup>	1204-RWR2-09-C

(1) For selection information, see Wiring and Grounding Guidelines for Pulse-width Modulated (PWM) AC Drives, publication [DRIVES-IN001](#), Appendix A.

(2) 1321-RWR products replace existing 1204-RWR products, 1204-RWRC modules (RWR and Common Mode Choke assembly) are still available.

## Reflective Wave Reduction Devices

1321-RWR devices are used at the output of the drive to reduce dv/dt and motor terminal peak voltages

480V, 60 Hz, Three-phase		
Drive Cat. No.	kW (Hp)	RWR Filter Cat. No.
20AD1P1-ND	0.37 (0.5)	—
20AD2P1-ND	0.75 (1.0)	—
20AD3P4-ND	1.5 (2.0)	—
20AD5P0-ND	2.2 (3.0)	—
20AD8P0-ND	4.0 (5.0)	1321-RWR8-DP
20AD011-ND	5.5 (7.5)	1321-RWR12-DP
20AD014-ND	7.5 (10)	1321-RWR18-DP
20AD022-ND	11 (15)	1321-RWR25-DP
20AD027-ND	15 (20)	1321-RWR35-DP
20AD034-ND	18.5 (25)	1321-RWR35-DP
20AD040-ND	22 (30)	1321-RWR45-DP
20AD052-ND	30 (40)	1321-RWR55-DP
20AD065-ND	37 (50)	1321-RWR80-DP

600V, 60 Hz, Three-phase		
Drive Cat. No.	kW (Hp)	RWR Filter Cat. No.
20AE0P9-ND	0.37 (0.5)	—
20AE1P7-ND	0.75 (1.0)	—
20AE2P7-ND	1.5 (2.0)	—
20AE3P9-ND	2.2 (3.0)	—
20AE6P1-ND	4.0 (5.0)	1321-RWR8-EP
20AE9P0-ND	5.5 (7.5)	1321-RWR12-EP
20AE011-ND	7.5 (10)	1321-RWR18-EP
20AE017-ND	11 (15)	1321-RWR25-EP
20AE022-ND	15 (20)	1321-RWR35-EP
20AE027-ND	18.5 (25)	1321-RWR45-EP
20AE032-ND	22 (30)	1321-RWR55-EP
20AE041-ND	30 (40)	1321-RWR80-EP
20AE052-ND	37 (50)	1321-RWR100-EP

## Isolation Transformers

For installations that have specific types of AC supply configurations or require drive protection due to AC line disturbances, isolation transformers are available. The isolation transformers are IP32, NEMA/UL Type 3R Standalone, 4...6% Nominal Impedance.

Motor Rating		240V, 60 Hz, Three-phase, 240V Primary, and 240V Secondary	460V, 60 Hz, Three-phase, 460V Primary, and 460V Secondary	575V, 60 Hz, Three-phase, 575V Primary, and 575V Secondary
kW	Hp	Cat. No.	Cat. No.	Cat. No.
0.25	0.33	—	1321-3TW005-BB	—
0.37	0.5	—	1321-3TW005-BB	1321-3TW005-CC
0.55	0.75	—	1321-3TW005-BB	—
0.75	1.0	—	1321-3TW005-BB	1321-3TW005-CC
1.1	1.5	—	1321-3TW005-BB	—
1.5	2.0	—	1321-3TW005-BB	1321-3TW005-CC
2.2	3.0	—	1321-3TW005-BB	1321-3TW005-CC
4.0	5.0	1321-3TW007-AA	1321-3TW007-BB	1321-3TW007-CC
5.5	7.5	1321-3TW011-AA	1321-3TW011-BB	1321-3TW011-CC
7.5	10	1321-3TW014-AA	1321-3TW014-BB	1321-3TW014-CC
11	15	1321-3TW020-AA	1321-3TW020-BB	1321-3TW020-CC
15	20	1321-3TW027-AA	1321-3TW027-BB	1321-3TW027-CC
18.5	25	1321-3TW034-AA	1321-3TW034-BB	1321-3TW034-CC
22	30	—	1321-3TW040-BB	1321-3TW040-CC
30	40	—	1321-3TW051-BB	1321-3TW051-CC
37	50	—	1321-3TH063-BB	1321-3TH063-CC

## Input Line Reactors and Output Line Reactors

For impedance matching, protection from AC line disturbances or motor protection, reactors are available for both the input and output sides of the drive.

### 240V, 60 Hz, Three-phase, 3% Impedance

Drive Cat. No.	Duty	Hp	Input Line Reactor <sup>(1)</sup>		Output Line Reactor <sup>(1)</sup>	
			IPOO (NEMA / UL Type Open) Cat. No.	IP11 (NEMA / UL Type 1) Cat. No.	IPOO (NEMA / UL Type Open) Cat. No.	IP11 (NEMA / UL Type 1) Cat. No.
20AB2P2	Heavy Duty	0.33	1321-3R2-D	1321-3RA2-D	1321-3R2-D	1321-3RA2-D
20AB2P2	Normal Duty	0.5	1321-3R2-D	1321-3RA2-D	1321-3R2-D	1321-3RA2-D
20AB4P2	Heavy Duty	0.75	1321-3R4-A	1321-3RA4-A	1321-3R4-A	1321-3RA4-A
20AB4P2	Normal Duty	1	1321-3R4-A	1321-3RA4-A	1321-3R4-A	1321-3RA4-A
20AB6P8	Heavy Duty	1.5	1321-3R8-B	1321-3RA8-B	1321-3R8-A	1321-3RA8-A
20AB6P8	Normal Duty	2	1321-3R8-A	1321-3RA8-A	1321-3R8-A	1321-3RA8-A
20AB9P6	Heavy Duty	2	1321-3R8-A	1321-3RA8-A	1321-3R12-A	1321-3RA12-A
20AB9P6	Normal Duty	3	1321-3R12-A	1321-3RA12-A	1321-3R12-A	1321-3RA12-A
20AB015	Heavy Duty	3	1321-3R12-A	1321-3RA12-A	1321-3R18-A	1321-3RA18-A
20AB015	Normal Duty	5	1321-3R18-A	1321-3RA18-A	1321-3R18-A	1321-3RA18-A
20AB022	Heavy Duty	5	1321-3R18-A	1321-3RA18-A	1321-3R25-A	1321-3RA25-A
20AB022	Normal Duty	7.5	1321-3R25-A	1321-3RA25-A	1321-3R25-A	1321-3RA25-A
20AB028	Heavy Duty	7.5	1321-3R25-A	1321-3RA25-A	1321-3R35-A	1321-3RA35-A
20AB028	Normal Duty	10	1321-3R35-A	1321-3RA35-A	1321-3R35-A	1321-3RA35-A
20AB042	Heavy Duty	10	1321-3R35-A	1321-3RA35-A	1321-3R45-A	1321-3RA45-A
20AB042	Normal Duty	15	1321-3R45-A	1321-3RA45-A	1321-3R45-A	1321-3RA45-A
20AB054	Heavy Duty	15	1321-3R45-A	1321-3RA45-A	1321-3R55-A	1321-3RA55-A
20AB054	Normal Duty	20	1321-3R55-A	1321-3RA55-A	1321-3R55-A	1321-3RA55-A
20AB070	Heavy Duty	20	1321-3R55-A	1321-3RA55-A	1321-3R80-A	1321-3RA80-A
20AB070	Normal Duty	25	1321-3R80-A	1321-3RA80-A	1321-3R80-A	1321-3RA80-A

(1) Input line reactors were sized based on the NEC Fundamental Motor Amps. Output line reactors were sized based on the VFD rated output currents.

### 240V, 60 Hz, Three-phase, 5% Impedance

Drive Cat. No.	Duty	Hp	Input Line Reactor <sup>(1)</sup>		Output Line Reactor <sup>(1)</sup>	
			IPOO (NEMA / UL Type Open) Cat. No.	IP11 (NEMA / UL Type 1) Cat. No.	IPOO (NEMA / UL Type Open) Cat. No.	IP11 (NEMA / UL Type 1) Cat. No.
20AB2P2	Heavy Duty	0.33	1321-3R2-A	1321-3RA2-A	1321-3R2-A	1321-3RA2-A
20AB2P2	Normal Duty	0.5	1321-3R2-A	1321-3RA2-A	1321-3R2-A	1321-3RA2-A
20AB4P2	Heavy Duty	0.75	1321-3R4-B	1321-3RA4-B	1321-3R4-B	1321-3RA4-B
20AB4P2	Normal Duty	1	1321-3R4-B	1321-3RA4-B	1321-3R4-B	1321-3RA4-B
20AB6P8	Heavy Duty	1.5	1321-3R8-B	1321-3RA8-B	1321-3R8-B	1321-3RA8-B
20AB6P8	Normal Duty	2	1321-3R8-B	1321-3RA8-B	1321-3R8-B	1321-3RA8-B
20AB9P6	Heavy Duty	2	1321-3R8-B	1321-3RA8-B	1321-3R12-B	1321-3RA12-B
20AB9P6	Normal Duty	3	1321-3R12-B	1321-3RA12-B	1321-3R12-B	1321-3RA12-B
20AB015	Heavy Duty	3	1321-3R12-B	1321-3RA12-B	1321-3R18-B	1321-3RA18-B
20AB015	Normal Duty	5	1321-3R18-B	1321-3RA18-B	1321-3R18-B	1321-3RA18-B
20AB022	Heavy Duty	5	1321-3R18-B	1321-3RA18-B	1321-3R25-B	1321-3RA25-B
20AB022	Normal Duty	7.5	1321-3R25-B	1321-3RA25-B	1321-3R25-B	1321-3RA25-B
20AB028	Heavy Duty	7.5	1321-3R25-B	1321-3RA25-B	1321-3R35-B	1321-3RA35-B
20AB028	Normal Duty	10	1321-3R35-B	1321-3RA35-B	1321-3R35-B	1321-3RA35-B
20AB042	Heavy Duty	10	1321-3R35-B	1321-3RA35-B	1321-3R45-B	1321-3RA45-B
20AB042	Normal Duty	15	1321-3R45-B	1321-3RA45-B	1321-3R45-B	1321-3RA45-B
20AB054	Heavy Duty	15	1321-3R45-B	1321-3RA45-B	1321-3R55-B	1321-3RA55-B
20AB054	Normal Duty	20	1321-3R55-B	1321-3RA55-B	1321-3R55-B	1321-3RA55-B
20AB070	Heavy Duty	20	1321-3R55-B	1321-3RA55-B	1321-3R80-B	1321-3RA80-B
20AB070	Normal Duty	25	1321-3R80-B	1321-3RA80-B	1321-3R80-B	1321-3RA80-B

(1) Input line reactors were sized based on the NEC Fundamental Motor Amps. Output line reactors were sized based on the VFD rated output currents.

### 480V, 60 Hz, Three-phase, 3% Impedance

Drive Cat. No.	Duty	Hp	Input Line Reactor <sup>(1)</sup>		Output Line Reactor <sup>(1)</sup>	
			IPOO (NEMA / UL Type Open)	IP11 (NEMA / UL Type 1)	IPOO (NEMA / UL Type Open)	IP11 (NEMA / UL Type 1)
			Cat. No.	Cat. No.	Cat. No.	Cat. No.
20AD1P1	Heavy Duty	0.33	1321-3R1-C	1321-3RA1-C	1321-3R2-B	1321-3RA2-B
20AD1P1	Normal Duty	0.5	1321-3R1-C	1321-3RA1-C	1321-3R2-B	1321-3RA2-B
20AD2P1	Heavy Duty	0.75	1321-3R2-A	1321-3RA2-A	1321-3R2-A	1321-3RA2-A
20AD2P1	Normal Duty	1	1321-3R2-A	1321-3RA2-A	1321-3R2-A	1321-3RA2-A
20AD3P4	Heavy Duty	1.5	1321-3R4-C	1321-3RA4-C	1321-3R4-B	1321-3RA4-B
20AD3P4	Normal Duty	2	1321-3R4-B	1321-3RA4-B	1321-3R4-B	1321-3RA4-B
20AD5P0	Heavy Duty	2	1321-3R4-B	1321-3RA4-B	1321-3R8-C	1321-3RA8-C
20AD5P0	Normal Duty	3	1321-3R8-C	1321-3RA8-C	1321-3R8-C	1321-3RA8-C
20AD8P0	Heavy Duty	3	1321-3R8-C	1321-3RA8-C	1321-3R8-B	1321-3RA8-B
20AD8P0	Normal Duty	5	1321-3R8-B	1321-3RA8-B	1321-3R8-B	1321-3RA8-B
20AD011	Heavy Duty	5	1321-3R8-B	1321-3RA8-B	1321-3R12-B	1321-3RA12-B
20AD011	Normal Duty	7.5	1321-3R12-B	1321-3RA12-B	1321-3R12-B	1321-3RA12-B
20AD014	Heavy Duty	7.5	1321-3R12-B	1321-3RA12-B	1321-3R18-B	1321-3RA18-B
20AD014	Normal Duty	10	1321-3R18-B	1321-3RA18-B	1321-3R18-B	1321-3RA18-B
20AD022	Heavy Duty	10	1321-3R18-B	1321-3RA18-B	1321-3R25-B	1321-3RA25-B
20AD022	Normal Duty	15	1321-3R25-B	1321-3RA25-B	1321-3R25-B	1321-3RA25-B
20AD027	Heavy Duty	15	1321-3R25-B	1321-3RA25-B	1321-3R25-B	1321-3RA25-B
20AD027	Normal Duty	20	1321-3R35-B	1321-3RA35-B	1321-3R25-B	1321-3RA25-B
20AD034	Heavy Duty	20	1321-3R35-B	1321-3RA35-B	1321-3R35-B	1321-3RA35-B
20AD034	Normal Duty	25	1321-3R35-B	1321-3RA35-B	1321-3R35-B	1321-3RA35-B
20AD040	Heavy Duty	25	1321-3R35-B	1321-3RA35-B	1321-3R45-B	1321-3RA45-B
20AD040	Normal Duty	30	1321-3R45-B	1321-3RA45-B	1321-3R45-B	1321-3RA45-B
20AD052	Heavy Duty	30	1321-3R45-B	1321-3RA45-B	1321-3R55-B	1321-3RA55-B
20AD052	Normal Duty	40	1321-3R55-B	1321-3RA55-B	1321-3R55-B	1321-3RA55-B
20AD065	Heavy Duty	40	1321-3R55-B	1321-3RA55-B	1321-3R80-B	1321-3RA80-B
20AD065	Normal Duty	50	1321-3R80-B	1321-3RA80-B	1321-3R80-B	1321-3RA80-B

(1) Input line reactors were sized based on the NEC Fundamental Motor Amps. Output line reactors were sized based on the VFD rated output currents.

### 480V, 60 Hz, Three-phase, 5% Impedance

Drive Cat. No.	Duty	Hp	Input Line Reactor <sup>(1)</sup>		Output Line Reactor <sup>(1)</sup>	
			IPOO (NEMA / UL Type Open)	IP11 (NEMA / UL Type 1)	IPOO (NEMA / UL Type Open)	IP11 (NEMA / UL Type 1)
			Cat. No.	Cat. No.	Cat. No.	Cat. No.
20AD1P1	Heavy Duty	0.33	1321-3R1-B	1321-3RA1-B	1321-3R2-C	1321-3RA2-C
20AD1P1	Normal Duty	0.5	1321-3R1-B	1321-3RA1-B	1321-3R2-C	1321-3RA2-C
20AD2P1	Heavy Duty	0.75	1321-3R2-C	1321-3RA2-C	1321-3R2-B	1321-3RA2-B
20AD2P1	Normal Duty	1	1321-3R2-B	1321-3RA2-B	1321-3R2-B	1321-3RA2-B
20AD3P4	Heavy Duty	1.5	1321-3R4-D	1321-3RA4-D	1321-3R4-D	1321-3RA4-D
20AD3P4	Normal Duty	2	1321-3R4-D	1321-3RA4-D	1321-3R4-D	1321-3RA4-D
20AD5P0	Heavy Duty	2	1321-3R4-D	1321-3RA4-D	1321-3R8-D	1321-3RA8-D
20AD5P0	Normal Duty	3	1321-3R8-D	1321-3RA8-D	1321-3R8-D	1321-3RA8-D
20AD8P0	Heavy Duty	3	1321-3R8-D	1321-3RA8-D	1321-3R8-C	1321-3RA8-C
20AD8P0	Normal Duty	5	1321-3R8-C	1321-3RA8-C	1321-3R8-C	1321-3RA8-C
20AD011	Heavy Duty	5	1321-3R8-C	1321-3RA8-C	1321-3R12-C	1321-3RA12-C
20AD011	Normal Duty	7.5	1321-3R12-C	1321-3RA12-C	1321-3R12-C	1321-3RA12-C
20AD014	Heavy Duty	7.5	1321-3R12-C	1321-3RA12-C	1321-3R18-C	1321-3RA18-C
20AD014	Normal Duty	10	1321-3R18-C	1321-3RA18-C	1321-3R18-C	1321-3RA18-C
20AD022	Heavy Duty	10	1321-3R18-C	1321-3RA18-C	1321-3R25-C	1321-3RA25-C
20AD022	Normal Duty	15	1321-3R25-C	1321-3RA25-C	1321-3R25-C	1321-3RA25-C
20AD027	Heavy Duty	15	1321-3R25-C	1321-3RA25-C	1321-3R25-C	1321-3RA25-C
20AD027	Normal Duty	20	1321-3R35-C <sup>(2)</sup>	1321-3RA35-C <sup>(2)</sup>	1321-3R25-C	1321-3RA25-C
20AD034	Heavy Duty	20	1321-3R35-C <sup>(2)</sup>	1321-3RA35-C <sup>(2)</sup>	1321-3R35-C	1321-3RA35-C
20AD034	Normal Duty	25	1321-3R35-C	1321-3RA35-C	1321-3R35-C	1321-3RA35-C
20AD040	Heavy Duty	25	1321-3R35-C	1321-3RA35-C	1321-3R45-C	1321-3RA45-C
20AD040	Normal Duty	30	1321-3R45-C	1321-3RA45-C	1321-3R45-C	1321-3RA45-C
20AD052	Heavy Duty	30	1321-3R45-C	1321-3RA45-C	1321-3R55-C	1321-3RA55-C
20AD052	Normal Duty	40	1321-3R55-C	1321-3RA55-C	1321-3R55-C	1321-3RA55-C
20AD065	Heavy Duty	40	1321-3R55-C	1321-3RA55-C	1321-3R80-C	1321-3RA80-C
20AD065	Normal Duty	50	1321-3R80-C	1321-3RA80-C	1321-3R80-C	1321-3RA80-C

(1) Input line reactors were sized based on the NEC Fundamental Motor Amps. Output line reactors were sized based on the VFD rated output currents.

(2) 4% impedance.

### 600V, 60 Hz, Three-phase, 3% Impedance

Drive Cat. No.	Duty	Hp	Input Line Reactor <sup>(1)</sup>		Output Line Reactor <sup>(1)</sup>	
			IPOO (NEMA / UL Type Open)	IP11 (NEMA / UL Type 1)	IPOO (NEMA / UL Type Open)	IP11 (NEMA / UL Type 1)
			Cat. No.	Cat. No.	Cat. No.	Cat. No.
20AEO9	Heavy Duty	0.33	1321-3R1-C	1321-3RA1-C	1321-3R1-B	1321-3RA1-B
20AEO9	Normal Duty	0.5	1321-3R1-C	1321-3RA1-C	1321-3R1-B	1321-3RA1-B
20AE1P7	Heavy Duty	0.5	1321-3R2-B	1321-3RA2-B	1321-3R2-B	1321-3RA2-B
20AE1P7	Normal Duty	1	1321-3R2-B	1321-3RA2-B	1321-3R2-B	1321-3RA2-B
20AE2P7	Heavy Duty	1	1321-3R2-A	1321-3RA2-A	1321-3R4-D	1321-3RA4-D
20AE2P7	Normal Duty	2	1321-3R4-C	1321-3RA4-C	1321-3R4-D	1321-3RA4-D
20AE3P9	Heavy Duty	2	1321-3R4-C	1321-3RA4-C	1321-3R4-C	1321-3RA4-C
20AE3P9	Normal Duty	3	1321-3R4-C	1321-3RA4-C	1321-3R4-C	1321-3RA4-C
20AE6P1	Heavy Duty	3	1321-3R4-C	1321-3RA4-C	1321-3R8-C	1321-3RA8-C
20AE6P1	Normal Duty	5	1321-3R8-C	1321-3RA8-C	1321-3R8-C	1321-3RA8-C
20AE9P0	Heavy Duty	5	1321-3R8-C	1321-3RA8-C	1321-3R12-C	1321-3RA12-C
20AE9P0	Normal Duty	7.5	1321-3R12-C	1321-3RA12-C	1321-3R12-C	1321-3RA12-C
20AE011	Heavy Duty	7.5	1321-3R12-C	1321-3RA12-C	1321-3R12-B	1321-3RA12-B
20AE011	Normal Duty	10	1321-3R12-B	1321-3RA12-B	1321-3R12-B	1321-3RA12-B
20AE017	Heavy Duty	10	1321-3R12-B	1321-3RA12-B	1321-3R18-B	1321-3RA18-B
20AE017	Normal Duty	15	1321-3R18-B	1321-3RA18-B	1321-3R18-B	1321-3RA18-B
20AE022	Heavy Duty	15	1321-3R18-B	1321-3RA18-B	1321-3R25-B	1321-3RA25-B
20AE022	Normal Duty	20	1321-3R25-B	1321-3RA25-B	1321-3R25-B	1321-3RA25-B
20AE027	Heavy Duty	20	1321-3R25-B	1321-3RA25-B	1321-3R35-C	1321-3RA35-C
20AE027	Normal Duty	25	1321-3R35-C	1321-3RA35-C	1321-3R35-C	1321-3RA35-C
20AE032	Heavy Duty	25	1321-3R35-C	1321-3RA35-C	1321-3R35-B	1321-3RA35-B
20AE032	Normal Duty	30	1321-3R35-B	1321-3RA35-B	1321-3R35-B	1321-3RA35-B
20AE041	Heavy Duty	30	1321-3R35-B	1321-3RA35-B	1321-3R45-B	1321-3RA45-B
20AE041	Normal Duty	40	1321-3R45-B	1321-3RA45-B	1321-3R45-B	1321-3RA45-B
20AE052	Heavy Duty	40	1321-3R45-B	1321-3RA45-B	1321-3R55-B	1321-3RA55-B
20AE052	Normal Duty	50	1321-3R55-B	1321-3RA55-B	1321-3R55-B	1321-3RA55-B

(1) Input line reactors were sized based on the NEC Fundamental Motor Amps. Output line reactors were sized based on the VFD rated output currents.

### 600V, 60 Hz, Three-phase, 5% Impedance

Drive Cat. No.	Duty	Hp	Input Line Reactor <sup>(1)</sup>		Output Line Reactor <sup>(1)</sup>	
			IPOO (NEMA / UL Type Open)	IP11 (NEMA / UL Type 1)	IPOO (NEMA / UL Type Open)	IP11 (NEMA / UL Type 1)
			Cat. No.	Cat. No.	Cat. No.	Cat. No.
20AEO9	Heavy Duty	0.33	1321-3R1-A	1321-3RA1-A	1321-3R1-B	1321-3RA1-B
20AEO9	Normal Duty	0.5	1321-3R1-B	1321-3RA1-B	1321-3R1-B	1321-3RA1-B
20AE1P7	Heavy Duty	0.5	1321-3R1-B	1321-3RA1-B	1321-3R2-C	1321-3RA2-C
20AE1P7	Normal Duty	1	1321-3R2-C	1321-3RA2-C	1321-3R2-C	1321-3RA2-C
20AE2P7	Heavy Duty	1	1321-3R2-C	1321-3RA2-C	1321-3R4-D <sup>(2)</sup>	1321-3RA4-D <sup>(2)</sup>
20AE2P7	Normal Duty	2	1321-3R4-D <sup>(2)</sup>	1321-3RA4-D <sup>(2)</sup>	1321-3R4-D <sup>(2)</sup>	1321-3RA4-D <sup>(2)</sup>
20AE3P9	Heavy Duty	2	1321-3R4-D <sup>(2)</sup>	1321-3RA4-D <sup>(2)</sup>	1321-3R4-D	1321-3RA4-D
20AE3P9	Normal Duty	3	1321-3R4-D	1321-3RA4-D	1321-3R4-D	1321-3RA4-D
20AE6P1	Heavy Duty	3	1321-3R4-D	1321-3RA4-D	1321-3R8-D	1321-3RA8-D
20AE6P1	Normal Duty	5	1321-3R8-D	1321-3RA8-D	1321-3R8-D	1321-3RA8-D
20AE9P0	Heavy Duty	5	1321-3R8-D	1321-3RA8-D	1321-3R12-C <sup>(2)</sup>	1321-3RA12-C <sup>(2)</sup>
20AE9P0	Normal Duty	7.5	1321-3R12-C <sup>(2)</sup>	1321-3RA12-C <sup>(2)</sup>	1321-3R12-C <sup>(2)</sup>	1321-3RA12-C <sup>(2)</sup>
20AE011	Heavy Duty	7.5	1321-3R12-C <sup>(2)</sup>	1321-3RA12-C <sup>(2)</sup>	1321-3R12-C	1321-3RA12-C
20AE011	Normal Duty	10	1321-3R12-C	1321-3RA12-C	1321-3R12-C	1321-3RA12-C
20AE017	Heavy Duty	10	1321-3R12-C	1321-3RA12-C	1321-3R18-C	1321-3RA18-C
20AE017	Normal Duty	15	1321-3R18-C	1321-3RA18-C	1321-3R18-C	1321-3RA18-C
20AE022	Heavy Duty	15	1321-3R18-C	1321-3RA18-C	1321-3R25-C <sup>(2)</sup>	1321-3RA25-C <sup>(2)</sup>
20AE022	Normal Duty	20	1321-3R25-C <sup>(2)</sup>	1321-3RA25-C <sup>(2)</sup>	1321-3R25-C <sup>(2)</sup>	1321-3RA25-C <sup>(2)</sup>
20AE027	Heavy Duty	20	1321-3R25-C <sup>(2)</sup>	1321-3RA25-C <sup>(2)</sup>	1321-3R35-C <sup>(2)</sup>	1321-3RA35-C <sup>(2)</sup>
20AE027	Normal Duty	25	1321-3R35-C <sup>(2)</sup>	1321-3RA35-C <sup>(2)</sup>	1321-3R35-C <sup>(2)</sup>	1321-3RA35-C <sup>(2)</sup>
20AE032	Heavy Duty	25	1321-3R35-C <sup>(2)</sup>	1321-3RA35-C <sup>(2)</sup>	1321-3R35-C <sup>(2)</sup>	1321-3RA35-C <sup>(2)</sup>
20AE032	Normal Duty	30	1321-3R35-C <sup>(2)</sup>	1321-3RA35-C <sup>(2)</sup>	1321-3R35-C <sup>(2)</sup>	1321-3RA35-C <sup>(2)</sup>
20AE041	Heavy Duty	30	1321-3R35-C <sup>(2)</sup>	1321-3RA35-C <sup>(2)</sup>	1321-3R45-C	1321-3RA45-C
20AE041	Normal Duty	40	1321-3R45-C	1321-3RA45-C	1321-3R45-C	1321-3RA45-C
20AE052	Heavy Duty	40	1321-3R45-C	1321-3RA45-C	1321-3R55-C	1321-3RA55-C
20AE052	Normal Duty	50	1321-3R55-C	1321-3RA55-C	1321-3R55-C	1321-3RA55-C

(1) Input line reactors were sized based on the NEC Fundamental Motor Amps. Output line reactors were sized based on the VFD rated output currents.

(2) 4% impedance.

# Installation Power Wiring

The PowerFlex 70 has the following built in protective features to help simplify installation:

- Ground fault protection during startup and running helps verify reliability
- Electronic motor overload protection increases motor life
- Removable MOV to ground and common mode capacitors to ground verify compatibility with ungrounded systems. These devices must be disconnected if the drive is installed on an ungrounded, high-resistance, or B phase grounded distribution system. These devices must also be disconnected if a regenerative unit is used as a bus supply or brake.
- 6 kV transient protection increased robustness for 380...480V system voltages

There are many other factors that must be considered for optimal performance in any given application. The following block diagram highlights the primary installation considerations. Consult Wiring and Grounding Guidelines for Pulse Width Modulated (PWM) AC Drives, publication [DRIVES-IN001](#), for detailed recommendations on input power conditioning, dynamic braking, reflected wave protection, and motor cables types.

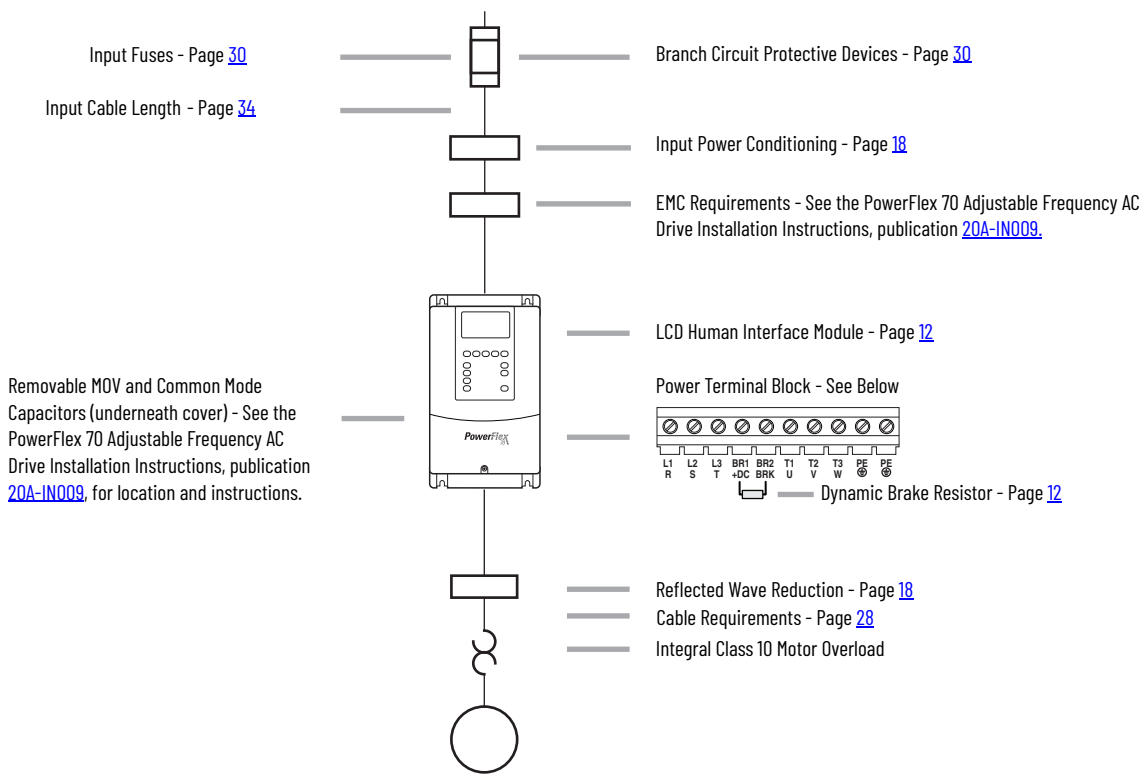

# Terminal Blocks

This section includes:

- [Terminal Block Specifications](#)
- [Hardware Enable Circuitry on page 25](#)
- [Safe Torque Off Board Terminal Block on page 25](#)
- [Encoder Interface Terminal Block on page 25](#)
- [EMC Filters on page 26](#)
- [Other Options on page 26](#)
- [I/O Wiring Examples on page 27](#)

## Terminal Block Specifications

No.	Name	Description	Frame	Wire Size Range <sup>(1)</sup>		Torque	
				Max, mm <sup>2</sup> (AWG)	Min, mm <sup>2</sup> (AWG)	Max, N•m (lb•in)	Recommended, N•m (lb•in)
①	I/O terminal block	Signal and control connections	All	1.5 (16)	0.05 (30)	0.55 (4.9)	0.5 (4.4)
②	Power terminal block	Input power and motor connections	A, B, and C	3.5 (12)	0.3 (22)	0.66 (5.5)	0.6 (5)
			D	8.4 (8)	0.8 (18)	1.7 (15)	1.4 (12)
			E	25.0 (3)	2.5 (14)	2.71 (24)	2.71 (24)
③	SHLD terminal	Terminating point for wiring shields	All	—	—	1.6 (14)	1.6 (14)

(1) These are the maximum/minimum sizes that the terminal block accepts, not recommendations.

Terminal	Description	Notes
BR1 BR2	DC brake (+) DC brake (-)	dB resistor connection - <b>Important:</b> Do not connect both an internal and external dB resistor simultaneously. This can violate the minimum allowed dB resistance and cause drive damage.
+DC -DC	DC bus (+) DC bus (-)	
PE	PE ground	④ Test point on Frames A...D on the left or right of the power terminal block. Frame E has a dedicated terminal.
U, V, W	U (T1), V (T2), W (T3)	To the motor
R, S, T	R (L1), S (L2), T (L3)	AC line input power

## Typical Terminal Block Location

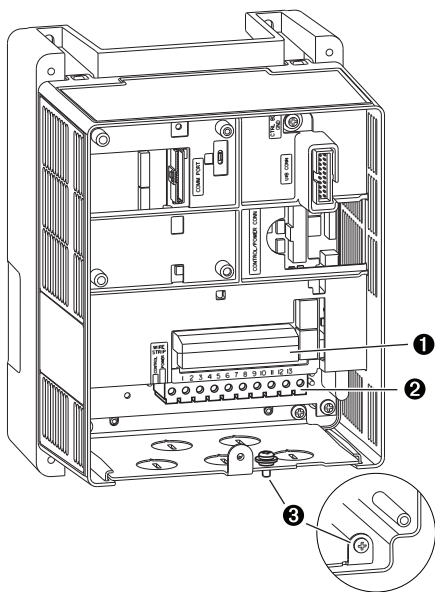

Power Terminals

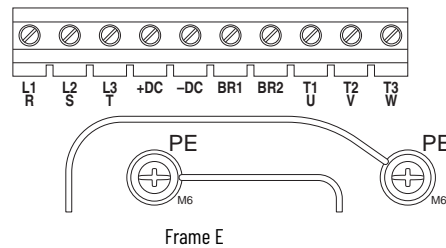
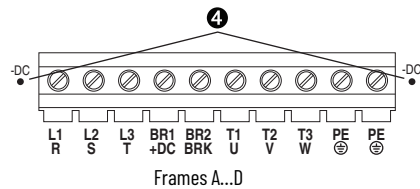

## Control Terminals

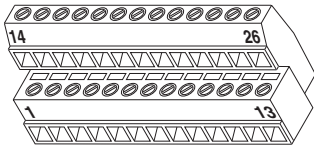

No.	Signal	Factory Default	Description	Related Parameters										
1	Digital In 1	Stop - CF (CF = clear fault)	11.2 mA at 24V DC 19.2V min on state 3.2V max off state Important: Use only 24V DC, not suitable for 115V AC circuitry. <sup>(3)</sup> Inputs can be wired as sink or source.	361...366										
2	Digital In 2	Start												
3	Digital In 3	Auto/Man												
4	Digital In 4	Speed Sel 1												
5	Digital In 5	Speed Sel 2												
6	Digital In 6	Speed Sel 3												
7	24V Common	-	Drive supplied power for digital In1...6 inputs only. Not intended for use on circuits outside of the drive. See examples beginning on <a href="#">page 27</a> .											
8	Digital In Common	-												
9	+24V DC	-	150 mA max load.											
10	+10V Pot Reference	-	2 k $\Omega$ min load.											
11	Digital Out 1 - N.O. <sup>(1)</sup>	NOT Fault	<table border="0"> <tr> <td><u>Max Resistive Load</u></td> <td><u>Max Inductive Load</u></td> </tr> <tr> <td>250V AC / 30V DC</td> <td>250V AC / 30V DC</td> </tr> <tr> <td>50VA / 60 Watts</td> <td>25VA / 30 Watts</td> </tr> <tr> <td><u>Min DC Load</u></td> <td></td> </tr> <tr> <td>10 <math>\mu</math>A, 10 mV DC</td> <td></td> </tr> </table>	<u>Max Resistive Load</u>	<u>Max Inductive Load</u>	250V AC / 30V DC	250V AC / 30V DC	50VA / 60 Watts	25VA / 30 Watts	<u>Min DC Load</u>		10 $\mu$ A, 10 mV DC		380...387
<u>Max Resistive Load</u>	<u>Max Inductive Load</u>													
250V AC / 30V DC	250V AC / 30V DC													
50VA / 60 Watts	25VA / 30 Watts													
<u>Min DC Load</u>														
10 $\mu$ A, 10 mV DC														
12	Digital Out 1 Common													
13	Digital Out 1 - N.C. <sup>(1)</sup>	Fault												
14	Analog In 1 (- Volts)	(2) Voltage - Reads value at 14 & 15	Non-isolated, 0...10V, 10 bit, 100 k $\Omega$ input impedance. <sup>(4)</sup>	320...327										
15	Analog In 1 (+ Volts)													
16	Analog In 1 (- Current)		Non-isolated, 4...20 mA, 10 bit, 100 $\Omega$ input impedance. <sup>(4)</sup>											
17	Analog In 1 (+ Current)													
18	Analog In 2 (- Volts)	(2) Voltage - Reads value at 18 & 19	Isolated, bipolar, differential, 0...10V unipolar (10 bit) or $\pm$ 10V bipolar (10 bit and sign), 100 k $\Omega$ input impedance. <sup>(5)</sup>											
19	Analog In 2 (+ Volts)													
20	Analog In 2 (- Current)		Isolated, 4...20mA, 10 bit and sign, 100 $\Omega$ input impedance. <sup>(5)</sup>											
21	Analog In 2 (+ Current)													
22	10V Pot Common	(2) Output Freq	0...10V, 10 bit, 10 k $\Omega$ (2 k $\Omega$ min) load. 0...20 mA, 10 bit, 400 $\Omega$ max load. <sup>(6)</sup> Referenced to chassis ground. Common if internal 10V supply (terminal 10) is used.	340...344										
23	Analog Out (- Volts) Analog Out (- Current)													
24	Digital Out 2 - N.O. <sup>(1)</sup>	Run	See description at Numbers 11...13.	380...387										
25	Digital Out 2 Common													
26	Digital Out 2 - N.C. <sup>(1)</sup>	NOT Run												

(1) Contacts shown in unpowered state. Any relay that is programmed as Fault or Alarm is energized (pick up) when power is applied to the drive and de-energize (drop out) when a fault or alarm exists. Relays selected for other functions are energized only when that condition exists and are de-energize when that condition is removed.

(2) These inputs/outputs are dependent on a number of parameters. For information on related parameters, see publication, [20A-UM001](#).

(3) For use with 115V AC circuitry. A 115V AC interface option (AK-M9-115VAC-1) must be used

(4) Differential isolation - external source must be less than 10V with respect to PE.

(5) Differential isolation - external source must be maintained at less than 160V with respect to PE. Input provides high common mode immunity.

(6) Analog output current is only available with enhanced control drives.

## Hardware Enable Circuitry

By default, you can program a digital input as an enable input. Drive software interprets the status of this input. If the application requires the drive to be disabled without software interpretation, a hardware enable configuration can be used. To set up a hardware enable configuration, use the following procedure:

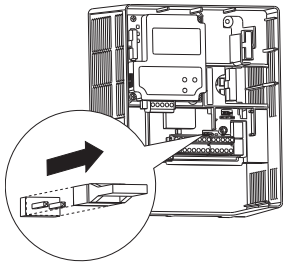

1. Remove the drive cover.
2. On the main control board, locate and remove the enable jumper (ENBL JMP).
3. Wire the enable input to Digital In 6.
4. Verify that 366 [Digital In6 Sel] is set to option 1 Enable.

## Safe Torque Off Board Terminal Block

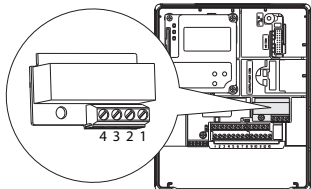

No.	Signal	Description
1	Monitor - N.C.	Normally closed contacts for monitoring relay status.
2	Common - N.C.	Max resistive load: 250V AC / 30V DC / 50V AC / 60 W Max inductive load: 250V AC / 30V DC / 25V AC / 30 W
3	+24V DC	
4	24V common	Connections for user-supplied power to energize coil.

For detailed connection examples, refer to the DriveGuard Safe Torque Off Option (Series B) for PowerFlex 40P and PowerFlex 70 Enhanced Control AC Drives User Manual, publication [PFLEX-UM003](#).

## Encoder Interface Terminal Block

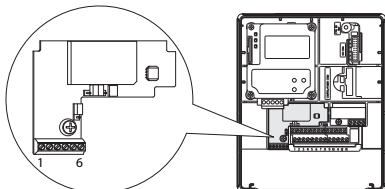

No.	Signal	Description	Jumper Settings
1	5...12V power <sup>(1)</sup>	Internal power source 250 mA (isolated)	
2	Power return		
3	Encoder B (NOT)	Single channel or quadrature B input.	
4	Encoder B		
5	Encoder A (NOT)	Single channel or quadrature A input.	
6	Encoder A		

(1) Jumper selectable +5...12V is available on 20A-ENC-1 encoder boards.

# Sample Encoder Wiring

I/O	Connection Example	I/O	Connection Example
<b>Encoder Power - Internal Drive Power</b> Internal (drive) 12V DC, 250 mA		<b>Encoder Power - External Power Source</b>	
<b>Encoder Signal - Single-Ended, Dual Channel</b>		<b>Encoder Signal - Differential, Dual Channel</b>	

## EMC Filters

Description	Factory-installed (Position 13)
Internal 3-phase 200...480 filter	A

The following two tables provide the catalog number codes for EMC filters, and the current ratings and voltages where filters are used. These tables are also provided in the [Catalog Number Explanation on page 6](#).

Emission Class	
Code	Rating
A	Filtered
N	Not Filtered

Emission Class by Frame Current Rating (A...E) and Voltage					
	A <sup>(1)(2)</sup>	B <sup>(2)</sup>	C	D	E
240V	A or N	A or N	A	A	A
400V	A or N	A or N	A	A	A
480V	A or N	A or N	A	A	A
600V	N	N	N	N	A

- (1) If a filter is used with a Frame A current rating, the drive with internal filter is supplied in the B Frame to accommodate the additional size.  
 (2) "A or N" indicates that filtering is optional.

## Other Options

Description	Catalog No.
	User Installed
Service connection board <sup>(1)</sup>	SK-M9-SCB1
115V AC interface card	AK-M9-115VAC-1
Frame E flange gasket	AK-M9-GASKET1-E4

- (1) Provides temporary DPI/HIM connection for NEMA 1 and flange drives with cover removed.

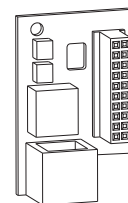

Service Connection Board  
SK-M9-SCB1

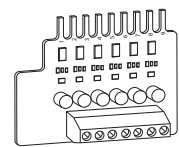

115V Interface Card  
AK-M9-115VAC-1

# I/O Wiring Examples

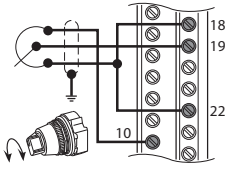
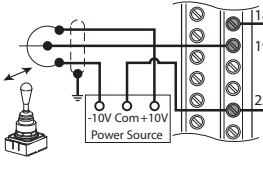
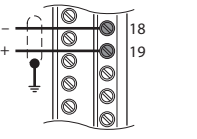
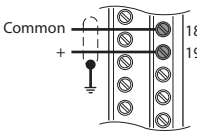
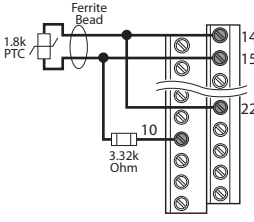
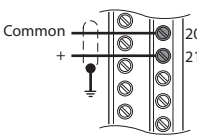
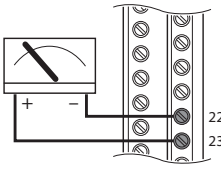
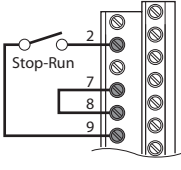
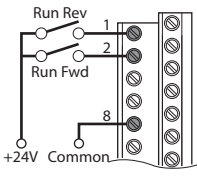
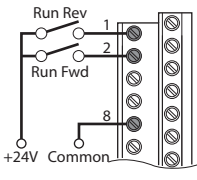
Input/Output	Connection Example	Required Parameter Settings
Potentiometer Unipolar Speed Reference 10 kΩ Pot. Recommended (2 kΩ min)		Select Speed Reference source: Param. 090 = 1 "Analog In 2" Adjust Scaling: Param. 091, 092, 322, 323 Check Results: Param. 016
Joystick Bipolar Speed Reference ±10V Input		Set Direction Mode: Param. 190 = 1 "Bipolar" Adjust Scaling: Param. 091, 092, 325, 326 Check Results: Param. 017
Analog Input Bipolar Speed Reference ±10V Input		Adjust Scaling: Param. 091, 092, 325, 326 Check Results: Param. 017
Analog Input Unipolar Speed Reference 0V...+10V Input		Adjust Scaling: Param. 091, 092, 325, 326 Check Results: Param. 017
Analog Input, PTC PTC OT set > 5V PTC OT cleared < 4V PTC Short < 0.2V		Set Fault Config 1: Param. 238, Bit #7 = 1 "Enabled"  Set Alarm Config 1: Param. 259, Bit #11 = 1 "Enabled"
Analog Input Unipolar Speed Reference 4...20 mA Input		Configure Input for Current: Param. 320, Bit #1 = 1 "Current" Adjust Scaling: Param. 091, 092, 325, 326 Check Results: Param. 017
Analog Output Unipolar 0V ...+10V Output. Can Drive a 2 kΩ load (25 mA short circuit limit)		Select Source Value: Param. 342 Adjust Scaling: Param. 343, 344
2 Wire Control Nonreversing	<b>Internal Supply</b> 	Disable Digital Input 1: Param. 361 = 0 "Not Used" Set Digital Input 2: Param. 362 = 7 "Run"
	<b>External Supply</b> 	
2 Wire Control Reversing		Set Digital Input 1: Param. 361 = 8 "Run Forward" Set Digital Input 2: Param. 362 = 9 "Run Reverse"

Input/Output	Connection Example	Required Parameter Settings
3 Wire Control	<p>Internal Supply</p>	Use factory default parameter settings.
3 Wire Control	<p>External Supply</p>	Use factory default parameter settings.
Digital Output Form C Relays Energized in Normal State.		Select Source: Param. 380, 384
Enable Input Shown in enabled state.		Configure with parameter 366 For dedicated hardware Enable: Remove Enable Jumper (ENBL JMP) on the Main Control Board.

## Cable Recommendations

This section includes:

- [Cable Types Acceptable for 200...600V Installations](#)
- [Recommended Shielded Wire on page 29](#)
- [Maximum Motor Cable Lengths on page 29](#)

### Cable Types Acceptable for 200...600V Installations

Various cable types are acceptable for drive installations. For many installations, unshielded cable is adequate, provided it can be separated from sensitive circuits. As an approximate guide, allow a spacing of 0.3 m (1 ft) for every 10 m (32.8 ft) of length. In all cases, long parallel runs must be avoided. Do not use cable with an insulation thickness less than or equal to 15 mils (0.4 mm/0.015 in.). Use copper wire only. Wire gauge requirements and recommendations are based on 75 °C (167 °F). Do not reduce wire gauge when using higher temperature wire. See [208/240 Volt AC Three-phase Input Drive Ratings and Input Protection Devices on page 30](#).

#### *Unshielded*

The following wire types are acceptable for drive installation in dry environments, as long as adequate free air space and/or conduit fill rate limits are provided: Thermoplastic High Heat-resistant Nylon-coated (THHN), Thermoplastic Heat and Water-resistant Nylon-coated (THWN), or similar wire. The wire must have a minimum insulation thickness of 15 mils (0.4 mm/0.015 in.) and cannot have large variations in insulation concentricity.

---

**IMPORTANT** Do not use THHN or similarly coated wire in wet areas.

---

## Shielded/Armored Cable

Shielded cable has the general benefits of multi-conductor cable. It also has the benefit of a copper braided shield that can contain much of the noise that a typical AC Drive generates. Use shielded cable for installations with sensitive equipment such as weigh scales, capacitive proximity switches, and other devices that can be affected by electrical noise in the distribution system. Applications with large numbers of drives in a similar location, imposed EMC regulations, or a high degree of communications/networking are also good candidates for shielded cable.

Shielded cable can also help reduce shaft voltage and induced bearing currents for some applications. In addition, the increased impedance of shielded cable can help extend the distance that the motor can be from the drive without the addition of motor protective devices, such as terminator networks. See Reflected Wave in Wiring and Grounding Guidelines for PWM AC Drives, publication [DRIVES-IN001](#).

Consider the general specifications of the environment of the installation, including temperature, flexibility, moisture characteristics, and chemical resistance. A braided shield can be included. If included, the braided shield is to be specified by the cable manufacturer as having coverage of at least 75%. An additional foil shield can greatly improve noise containment.

A good example of recommended cable is Belden 295 $_{xx}$  ( $_{xx}$  determines gauge). This cable has four Cross-linked Polyethylene (XLPE) insulated conductors with a 100% coverage foil and an 85% coverage copper braided shield (with drain wire) surrounded by a Polyvinyl Chloride (PVC) jacket.

Other types of shielded cable are available, but the use of these types can limit the allowable cable length. For example, some of the newer cables bundle four conductors of THHN wire and wrap them tightly with a foil shield. This type of construction can greatly increase the cable charging current that is required and reduce the overall drive performance. Unless specified in the individual distance tables as tested with the drive, these cables are not recommended and their performance against the lead length limits is not known.

## Recommended Shielded Wire

Location	Rating/Type	Description
Standard (option 2)	Tray rated 600V, 90 °C (194 °F) RHH/RHW-2 Anixter OLF-7 $_{xxxxx}$ or equivalent	Three tinned copper conductors with XLPE insulation. 5 mil single helical copper tape (25% overlap min) with three bare copper grounds in contact with the shield. PVC jacket.
Class I and II; Division I and II	Tray rated 600V, 90 °C (194 °F) RHH/RHW-2 Anixter 7V-7 $_{xxxx}$ -3G or equivalent	Three bare copper conductors with XLPE insulation and impervious corrugated continuously welded aluminum armor. Black sunlight resistant PVC jacket overall. Three copper grounds on #10 AWG and smaller.



**ATTENTION:** To avoid a possible shock hazard that is caused by induced voltages, unused wires in the conduit must be grounded at both ends. Also, if a drive sharing a conduit is being serviced or installed, disable all of the drives that are using that conduit. Disabling all of the drives that are using that conduit helps minimize the possible shock hazard from cross coupled motor leads.

## Maximum Motor Cable Lengths

For information on maximum motor cable lengths, refer to the Wiring and Grounding Guidelines for Pulse Width Modulated (PWM) AC Drives, publication [DRIVES-IN001](#).

# Power Ratings and Branch Circuit Protection

See the tables in this section for power ratings and branch circuit protection information.

## Single-phase Input Power

The PowerFlex 70 drive is typically used with a three-phase input supply. Single-phase operation of the drive is rated under the UL 508C listing. Rockwell Automation has verified that single-phase operation can be performed with output current that is derated by 50% of the three-phase ratings that are identified in the tables in this section.

### 208/240 Volt AC Three-phase Input Drive Ratings and Input Protection Devices

Cat.No.	Frame <sup>(1)</sup>	Hp Rating		Input Ratings		Output Amps			Dual Element Time Delay Fuse		Non-time Delay Fuse		Circuit Breaker <sup>(2)</sup>	Motor Circuit Protector <sup>(3)</sup>	140M Motor Protector with Adjustable Current Range <sup>(4)(5)</sup>			
		ND	HD	Amps	kVA	Cont.	60 s	3 s	Min <sup>(6)</sup>	Max <sup>(7)</sup>	Min <sup>(6)</sup>	Max <sup>(7)</sup>	Max <sup>(8)</sup>	Max <sup>(8)</sup>	Available Catalog Numbers <sup>(9)</sup>	Minimum Enclosure Volume (in. <sup>3</sup> ) <sup>(10)</sup>		
<b>208 Volt AC Input</b>																		
20AB2P2	A	0.5	0.33	2.9	1.1	2.5	2.7	3.7	6	6	6	10	15	7	140M-C2E-B40	140M-D8E-B40	—	3441
20AB4P2	A	1	0.75	5.6	2	4.8	5.5	7.4	10	10	10	17.5	15	7	140M-C2E-B63	140M-D8E-B63	—	3441
20AB6P8	B	2	1.5	10	3.6	7.8	10.3	13.8	15	15	15	30	30	15	140M-C2E-C10	140M-D8E-C10	140M-F8E-C10	3441
20AB9P6	B	3	2	14	5.1	11	12.1	16.5	20	25	20	40	40	30	140M-C2E-C16	140M-D8E-C16	140M-F8E-C16	3441
20AB015	C	5	3	16	5.8	17.5	19.2	26.6	20	35	20	70	70	30	140M-C2E-C20	140M-D8E-C20	140M-F8E-C20	3441
20AB022	D	7.5	5	23.3	8.3	25.3	27.8	37.9	30	50	30	100	100	30	—	140M-D8E-C25	140M-F8E-C25	5098
20AB028	D	10	7.5	29.8	10.7	32.2	37.9	50.6	40	70	40	125	125	50	—	—	140M-F8E-C32	5098
20AB042	D	15	10	39.8	14.3	43	55.5	74	60	100	60	175	175	70	—	—	140M-F8E-C45	5098
20AB054	E	20	15	57.5	20.7	62.1	72.4	96.6	80	125	80	200	200	100	—	—	—	—
20AB070	E	25	20	72.3	26.0	78.2	93.1	124	90	175	90	300	300	100	—	—	—	—
<b>240 Volt AC Input</b>																		
20AB2P2	A	0.5	0.33	2.5	1.1	2.2	2.4	3.3	3	4.5	3	8	15	3	140M-C2E-B25	140M-D8E-B25	—	3441
20AB4P2	A	1	0.75	4.8	2	4.2	4.8	6.4	6	9	6	15	15	7	140M-C2E-B63	140M-D8E-B63	—	3441
20AB6P8	B	2	1.5	8.7	3.6	6.8	9	12	15	15	15	25	25	15	140M-C2E-C10	140M-D8E-C10	140M-F8E-C10	3441
20AB9P6	B	3	2	12.2	5.1	9.6	10.6	14.4	20	20	20	35	35	15	140M-C2E-C16	140M-D8E-C16	140M-F8E-C16	3441
20AB015	C	5	3	13.9	5.8	15.3	17.4	23.2	20	30	20	60	60	30	140M-C2E-C16	140M-D8E-C16	140M-F8E-C16	3441
20AB022	D	7.5	5	19.9	8.3	22	24.4	33	25	45	25	80	80	30	—	140M-D8E-C25	140M-F8E-C25	5098
20AB028	D	10	7.5	25.7	10.7	28	33	44	35	60	35	110	110	50	—	—	140M-F8E-C32	5098
20AB042	D	15	10	38.7	16.1	42	46.2	63	50	90	50	150	150	50	—	—	140M-F8E-C45	5098
20AB054	E	20	15	49.8	20.7	54	63	84	60	100	60	200	200	100	—	—	—	—
20AB070	E	25	20	64.5	26.8	70	81	108	90	150	90	275	275	100	—	—	—	—

See page 33 for notes.

### 400/480 Volt AC Three-phase Input Drive Ratings and Input Protection Devices

Cat.No.	Frame <sup>(1)</sup>	Hp Rating		Input Ratings		Output Amps			Dual Element Time Delay Fuse		Non-time Delay Fuse		Circuit Breaker <sup>(2)</sup>	Motor Circuit Protector <sup>(3)</sup>	140M Motor Protector with Adjustable Current Range <sup>(4)(5)</sup>			
		ND	HD	Amps	kVA	Cont.	60 s	3 s	Min <sup>(6)</sup>	Max <sup>(7)</sup>	Min <sup>(6)</sup>	Max <sup>(7)</sup>	Max <sup>(8)</sup>	Max <sup>(8)</sup>	Available Catalog Numbers <sup>(9)</sup>	Minimum Enclosure Volume (in. <sup>3</sup> ) <sup>(10)</sup>		
<b>400 Volt AC Input</b>																		
20AC1P3	A	0.37	0.25	1.6	1.1	1.3	1.4	1.9	3	3	3	5	15	3	140M-C2E-B16	—	—	3441
20AC2P1	A	0.75	0.55	2.5	1.8	2.1	2.4	3.2	4	6	4	8	15	7	140M-C2E-B25	140M-D8E-B25	—	3441
20AC3P5	A	1.5	1.1	4.3	3	3.5	4.5	6	6	6	6	12	15	7	140M-C2E-B63	140M-D8E-B63	—	3441
20AC5P0	B	2.2	1.5	6.5	4.5	5	5.5	7.5	10	10	10	20	20	15	140M-C2E-C10	140M-D8E-C10	140M-F8E-C10	3441
20AC8P7	B	4	3	11.3	7.8	8.7	9.9	13.2	15	17.5	15	30	30	15	140M-C2E-C16	140M-D8E-C16	140M-F8E-C16	3441

## 400/480 Volt AC Three-phase Input Drive Ratings and Input Protection Devices (Continued)

Cat.No.	Frame <sup>(1)</sup>	Hp Rating		Input Ratings		Output Amps			Dual Element Time Delay Fuse		Non-time Delay Fuse		Circuit Breaker (2)	Motor Circuit Protector (3)	140M Motor Protector with Adjustable Current Range <sup>(4)(5)</sup>			
		ND	HD	Amps	kVA	Cont.	60 s	3 s	Min <sup>(6)</sup>	Max <sup>(7)</sup>	Min <sup>(6)</sup>	Max <sup>(7)</sup>	Max <sup>(8)</sup>	Max <sup>(8)</sup>	Available Catalog Numbers <sup>(9)</sup>			Minimum Enclosure Volume (in. <sup>3</sup> ) <sup>(10)</sup>
20AC011	C	5.5	4	10.5	7.6	11.5	13	17.4	15	25	15	45	40	15	140M-C2E-C16	140M-D8E-C16	140M-F8E-C16	3441
20AC015	C	7.5	5.5	15.1	10.4	15.4	17.2	23.1	20	30	20	60	60	20	140M-C2E-C16	140M-D8E-C16	140M-F8E-C16	3441
20AC022	D	11	7.5	21.9	15.2	22	24.2	33	30	45	30	80	80	30	—	140M-D8E-C25	140M-F8E-C25	5098
20AC030	D	15	11	30.3	21	30	33	45	40	60	40	120	120	50	—	—	140M-F8E-C32	5098
20AC037	D	18.5	15	35	24.3	37	45	60	50	80	50	125	140	50	—	—	140M-F8E-C45	5098
20AC043	D	22	18.5	40.7	28.2	43	56	74	60	90	60	150	160	70	—	—	—	—
20AC060	E	30	22	56.8	39.3	60	66	90	80	125	80	225	240	80	—	—	—	—
20AC072	E	37	30	68.9	47.8	72	90	120	90	150	90	250	280	100	—	—	—	—

### 480 Volt AC Input

20AD1P1	A	0.5	0.33	1.3	1.1	1.1	1.2	1.6	3	3	3	4	15	3	140M-C2E-B16	—	—	3441
20AD2P1	A	1	0.75	2.4	2	2.1	2.4	3.2	3	6	3	8	15	3	140M-C2E-B25	140M-D8E-B25	—	3441
20AD3P4	A	2	1.5	3.8	3.2	3.4	4.5	6	6	6	6	12	15	7	140M-C2E-B40	140M-D8E-B40	—	3441
20AD5P0	B	3	2	5.6	4.7	5	5.5	7.5	10	10	10	20	20	15	140M-C2E-B63	140M-D8E-B63	—	3441
20AD8P0	B	5	3	9.8	8.4	8	8.8	12	15	15	15	30	30	15	140M-C2E-C10	140M-D8E-C10	140M-F8E-C10	3441
20AD011	C	7.5	5	9.4	7.9	11	12.1	16.5	15	20	15	40	40	15	140M-C2E-C16	140M-D8E-C16	140M-F8E-C16	3441
20AD014	C	10	7.5	12.4	10.4	14	16.5	22	20	30	20	50	50	20	140M-C2E-C16	140M-D8E-C16	140M-F8E-C16	3441
20AD022	D	15	10	19.9	16.6	22	24.2	33	25	45	25	80	80	30	—	140M-D8E-C25	140M-F8E-C25	5098
20AD027	D	20	15	24.8	20.6	27	33	44	35	60	35	100	100	50	—	—	140M-F8E-C32	5098
20AD034	D	25	20	31.2	25.9	34	40.5	54	40	70	40	125	125	50	—	—	140M-F8E-C45	5098
20AD040	D	30	25	36.7	30.5	40	51	68	50	90	50	150	150	50	—	—	140M-F8E-C45	5098
20AD052	E	40	30	47.7	39.7	52	60	80	60	110	60	200	200	70	—	—	—	—
20AD065	E	50	40	59.6	49.6	65	78	104	80	125	80	250	250	100	—	—	—	—

See page 33 for notes.

## 600 Volt AC Three-phase Input Drive Ratings and Input Protection Devices

Cat.No.	Frame <sup>(1)</sup>	Hp Rating		Input Ratings		Output Amps			Dual Element Time Delay Fuse		Non-time Delay Fuse		Circuit Breaker (2)	Motor Circuit Protector (3)	140M Motor Protector with Adjustable Current Range <sup>(4)(5)</sup>			
		ND	HD	Amps	kVA	Cont.	60 s	3 s	Min <sup>(6)</sup>	Max <sup>(7)</sup>	Min <sup>(6)</sup>	Max <sup>(7)</sup>	Max <sup>(8)</sup>	Max <sup>(8)</sup>	Available Catalog Numbers <sup>(9)</sup>			Minimum Enclosure Volume (in. <sup>3</sup> ) <sup>(10)</sup>

### 600 Volt AC Input

20AE0P9	A	0.5	0.33	1.3	1.3	0.9	1.1	1.4	3	3	3	3.5	15	3	140M-C2E-B16	—	—	3441
20AE1P7	A	1	0.75	1.9	2	1.7	2	2.6	3	6	3	6	15	3	140M-C2E-B25	140M-D8E-B25	—	3441
20AE2P7	A	2	1.5	3	3.1	2.7	3.6	4.8	4	6	4	10	15	7	140M-C2E-B40	140M-D8E-B40	—	3441
20AE3P9	B	3	2	4.4	4.5	3.9	4.3	5.9	6	8	6	15	15	7	—	140M-D8E-B63	—	3441
20AE6P1	B	5	3	7.5	7.8	6.1	6.7	9.2	10	12	10	20	20	15	—	140M-D8E-C10	140M-F8E-C10	3441
20AE9P0	C	7.5	5	7.7	8	9	9.9	13.5	10	20	10	35	35	15	—	140M-D8E-C10	140M-F8E-C10	3441
20AE011	C	10	7.5	9.8	10.1	11	13.5	18	15	20	15	40	40	15	—	140M-D8E-C16	140M-F8E-C16	3441
20AE017	D	15	10	15.3	15.9	17	18.7	25.5	20	35	20	60	60	30	—	—	140M-F8E-C20	5098
20AE022	D	20	15	20	20.8	22	25.5	34	25	45	25	80	80	30	—	—	140M-F8E-C25	5098
20AE027	D	25	20	24.8	25.7	27	33	44	35	60	35	100	100	50	—	—	140M-F8E-C25	5098
20AE032	D	30	25	29.4	30.5	32	40.5	54	40	70	40	125	125	50	—	—	140M-F8E-C32	5098
20AE041	E	40	30	37.6	39.1	41	48	64	50	90	50	150	150	100	—	—	—	—
20AE052	E	50	40	47.7	49.6	52	61.5	82	60	110	60	200	200	100	—	—	—	—

See page 33 for notes.

## 208/240 Volt AC Single-phase Input Drive Ratings and Input Protection Devices

Cat.No.	Frame (1)	Hp Rating		Input Ratings		Output Amps			Dual Element Time Delay Fuse		Non-time Delay Fuse		Circuit Breaker (2)	Motor Circuit Protector (3)	140M Motor Protector with Adjustable Current Range (4)(5)			
		ND	HD	Amps	kVA	Cont.	60 s	3 s	Min(6)	Max(7)	Min(6)	Max(7)	Max(8)	Max(8)	Available Catalog Numbers(9)		Minimum Enclosure Volume (in. 3)(10)	
<b>208 Volt AC Input</b>																		
20AB2P2	A	0.5	0.33	2.9	0.6	1.3	1.6	1.9	6	6	6	10	15	7	140M-C2E-B40	140M-D8E-B40	-	3441
20AB4P2	A	1	0.75	5.6	1	2.4	2.8	3.7	10	10	10	17.5	15	7	140M-C2E-B63	140M-D8E-B63	-	3441
20AB6P8	B	2	1.5	10	1.8	3.9	5.2	6.9	15	15	15	30	30	15	140M-C2E-C10	140M-D8E-C10	140M-F8E-C10	3441
20AB9P6	B	3	2	14	2.6	5.5	6.1	8.3	20	25	20	40	40	30	140M-C2E-C16	140M-D8E-C16	140M-F8E-C16	3441
20AB015	C	5	3	16	2.9	8.6	9.6	13.3	20	35	20	70	70	30	140M-C2E-C20	140M-D8E-C20	140M-F8E-C20	3441
20AB022	D	7.5	5	23.3	4.2	12.7	13.9	19.0	30	50	30	100	100	30	-	140M-D8E-C25	140M-F8E-C25	5098
20AB028	D	10	7.5	29.8	5.4	16.1	19	25.3	40	70	40	125	125	50	-	-	140M-F8E-C32	5098
20AB042	D	15	10	39.8	7.2	21.5	27.8	37	60	100	60	175	175	70	-	-	140M-F8E-C45	5098
20AB054	E	20	15	57.5	10.4	31.1	36.2	48.3	80	125	80	200	200	100	-	-	-	-
20AB070	E	25	20	72.3	13.0	39.1	46.6	62	90	175	90	300	300	100	-	-	-	-
<b>240 Volt AC Input</b>																		
20AB2P2	A	0.5	0.33	2.5	0.6	1.1	1.2	1.7	3	4.5	3	8	15	3	140M-C2E-B25	140M-D8E-B25	-	3441
20AB4P2	A	1	0.75	4.8	1	2.1	2.4	3.2	6	9	6	15	15	7	140M-C2E-B63	140M-D8E-B63	-	3441
20AB6P8	B	2	1.5	8.7	1.8	3.4	4.5	6	15	15	15	25	25	15	140M-C2E-C10	140M-D8E-C10	140M-F8E-C10	3441
20AB9P6	B	3	2	12.2	2.6	4.8	5.3	7.2	20	20	20	35	35	15	140M-C2E-C16	140M-D8E-C16	140M-F8E-C16	3441
20AB015	C	5	3	13.9	2.9	7.7	8.7	11.6	20	30	20	60	60	30	140M-C2E-C16	140M-D8E-C16	140M-F8E-C16	3441
20AB022	D	7.5	5	19.9	4.2	11	12.2	16.5	25	45	25	80	80	30	-	140M-D8E-C25	140M-F8E-C25	5098
20AB028	D	10	7.5	25.7	5.4	14	16.5	22	35	60	35	110	110	50	-	-	140M-F8E-C32	5098
20AB042	D	15	10	38.7	8.1	21	23.1	31.5	50	90	50	150	150	50	-	-	140M-F8E-C45	5098
20AB054	E	20	15	49.8	10.4	27	31.5	42	60	100	60	200	200	100	-	-	-	-
20AB070	E	25	20	64.5	13.4	35	40.5	54	90	150	90	275	275	100	-	-	-	-

See [page 33](#) for notes.

## 400/480 Volt AC Single-phase Input Drive Ratings and Input Protection Devices

Cat.No.	Frame (1)	Hp Rating		Input Ratings		Output Amps			Dual Element Time Delay Fuse		Non-time Delay Fuse		Circuit Breaker (2)	Motor Circuit Protector (3)	140M Motor Protector with Adjustable Current Range (4)(5)			
		ND	HD	Amps	kVA	Cont.	60 s	3 s	Min(6)	Max(7)	Min(6)	Max(7)	Max(8)	Max(8)	Available Catalog Numbers(9)		Minimum Enclosure Volume (in. 3)(10)	
<b>400 Volt AC Input</b>																		
20AC1P3	A	0.37	0.25	1.6	0.6	0.7	0.7	1.0	3	3	3	5	15	3	140M-C2E-B16	-	-	3441
20AC2P1	A	0.75	0.55	2.5	0.9	1.1	1.2	1.6	4	6	4	8	15	7	140M-C2E-B25	140M-D8E-B25	-	3441
20AC3P5	A	1.5	1.1	4.3	1.5	1.8	2.3	3	6	6	6	12	15	7	140M-C2E-B63	140M-D8E-B63	-	3441
20AC5P0	B	2.2	1.5	6.5	2.3	2.5	2.8	3.8	10	10	10	20	20	15	140M-C2E-C10	140M-D8E-C10	140M-F8E-C10	3441
20AC8P7	B	4	3	11.3	3.9	4.4	5.0	6.6	15	17.5	15	30	30	15	140M-C2E-C16	140M-D8E-C16	140M-F8E-C16	3441
20AC011	C	5.5	4	11	3.8	5.8	6.5	8.7	15	25	15	45	40	15	140M-C2E-C16	140M-D8E-C16	140M-F8E-C16	3441
20AC015	C	7.5	5.5	15.1	5.2	7.7	8.6	11.6	20	30	20	60	60	20	140M-C2E-C16	140M-D8E-C16	140M-F8E-C16	3441
20AC022	D	11	7.5	21.9	7.6	11	12.1	16.5	30	45	30	80	80	30	-	140M-D8E-C25	140M-F8E-C25	5098
20AC030	D	15	11	30.3	10.5	15	16.5	22.5	40	60	40	120	120	50	-	-	140M-F8E-C32	5098
20AC037	D	18.5	15	35	12.2	18.5	22.5	30	50	80	50	125	140	50	-	-	140M-F8E-C45	5098
20AC043	D	22	18.5	40.7	14.1	21.5	28	37	60	90	60	150	160	70	-	-	-	-
20AC060	E	30	22	56.8	19.7	30	33	45	80	125	80	225	240	80	-	-	-	-
20AC072	E	37	30	68.9	23.9	36	45	60	90	150	90	250	280	100	-	-	-	-
<b>480 Volt AC Input</b>																		
20AD1P1	A	0.5	0.33	1.3	0.6	0.6	0.6	0.8	3	3	3	4	15	3	140M-C2E-B16	-	-	3441
20AD2P1	A	1	0.75	2.4	1	1.1	1.2	1.6	3	6	3	8	15	3	140M-C2E-B25	140M-D8E-B25	-	3441

## 400/480 Volt AC Single-phase Input Drive Ratings and Input Protection Devices (Continued)

Cat.No.	Frame <sup>(1)</sup>	Hp Rating		Input Ratings		Output Amps			Dual Element Time Delay Fuse		Non-time Delay Fuse		Circuit Breaker (2)	Motor Circuit Protector (3)	140M Motor Protector with Adjustable Current Range <sup>(4)(5)</sup>			
		ND	HD	Amps	kVA	Cont.	60 s	3 s	Min <sup>(6)</sup>	Max <sup>(7)</sup>	Min <sup>(6)</sup>	Max <sup>(7)</sup>	Max <sup>(8)</sup>	Max <sup>(8)</sup>	Available Catalog Numbers <sup>(9)</sup>			Minimum Enclosure Volume (in. <sup>3</sup> ) <sup>(10)</sup>
20AD3P4	A	2	1.5	3.8	1.6	1.7	2.3	3	6	6	6	12	15	7	140M-C2E-B40	140M-D8E-B40	-	3441
20AD5P0	B	3	2	5.6	2.4	2.5	2.6	3.8	10	10	10	20	20	15	140M-C2E-B63	140M-D8E-B63	-	3441
20AD8P0	B	5	3	9.8	4.2	4	4.4	6	15	15	15	30	30	15	140M-C2E-C10	140M-D8E-C10	140M-F8E-C10	3441
20AD011	C	7.5	5	9.5	4	5.5	6.1	8.3	15	20	15	40	40	15	140M-C2E-C16	140M-D8E-C16	140M-F8E-C16	3441
20AD014	C	10	7.5	12.5	5.2	7	8.3	11	20	30	20	50	50	20	140M-C2E-C16	140M-D8E-C16	140M-F8E-C16	3441
20AD022	D	15	10	19.9	8.3	11	12.1	16.5	25	45	25	80	80	30	-	140M-D8E-C25	140M-F8E-C25	5098
20AD027	D	20	15	24.8	10.3	13.5	16.5	22	35	60	35	100	100	50	-	-	140M-F8E-C32	5098
20AD034	D	25	20	31.2	13	17	20.3	27	40	70	40	125	125	50	-	-	140M-F8E-C45	5098
20AD040	D	30	25	36.7	19.9	20	25.5	34	50	90	50	150	150	50	-	-	140M-F8E-C45	5098
20AD052	E	40	30	47.7	12.8	26	30	40	60	110	60	200	200	70	-	-	-	-
20AD065	E	50	40	59.6	24.8	32.5	39	52	80	125	80	250	250	100	-	-	-	-

See [page 33](#) for notes.

## 600 Volt AC Single-phase Input Drive Ratings and Input Protection Devices

Cat. No.	Frame <sup>(1)</sup>	Hp Rating		Input Ratings		Output Amps			Dual Element Time Delay Fuse		Non-time Delay Fuse		Circuit Breaker (2)	Motor Circuit Protector (3)	140M Motor Protector with Adjustable Current Range <sup>(4)(5)</sup>			
		ND	HD	Amps	kVA	Cont.	60 s	3 s	Min <sup>(6)</sup>	Max <sup>(7)</sup>	Min <sup>(6)</sup>	Max <sup>(7)</sup>	Max <sup>(8)</sup>	Max <sup>(8)</sup>	Available Catalog Numbers <sup>(9)</sup>			Minimum Enclosure Volume (in. <sup>3</sup> ) <sup>(10)</sup>
20AE0P9	A	0.5	0.33	1.3	0.7	0.5	0.6	0.7	3	3	3	3.5	15	3	140M-C2E-B16	-	-	3441
20AE1P7	A	1	0.75	1.9	1	0.9	1	1.3	3	6	3	6	15	3	140M-C2E-B25	140M-D8E-B25	-	3441
20AE2P7	A	2	1.5	3	1.6	1.4	1.8	2.4	4	6	4	10	15	7	140M-C2E-B40	140M-D8E-B40	-	3441
20AE3P9	B	3	2	4.4	2.3	2	2.2	3	6	8	6	15	15	7	-	140M-D8E-B63	-	3441
20AE6P1	B	5	3	7.5	3.9	3.1	3.4	4.6	10	12	10	20	20	15	-	140M-D8E-C10	140M-F8E-C10	3441
20AE9P0	C	7.5	5	7.7	4	4.5	5	6.8	10	20	10	35	35	15	-	140M-D8E-C10	140M-F8E-C10	3441
20AE011	C	10	7.5	9.8	5.1	5.5	6.8	9	15	20	15	40	40	15	-	140M-D8E-C16	140M-F8E-C16	3441
20AE017	D	15	10	15.3	8	8.5	9.4	12.8	20	35	20	60	60	30	-	-	140M-F8E-C20	5098
20AE022	D	20	15	20	10.4	11	12.8	17	25	45	25	80	80	30	-	-	140M-F8E-C25	5098
20AE027	D	25	20	24.8	12.9	13.5	16.5	22	35	60	35	100	100	50	-	-	140M-F8E-C25	5098
20AE032	D	30	25	29.4	15.3	16	20.3	27	40	70	40	125	125	50	-	-	140M-F8E-C32	5098
20AE041	E	40	30	37.6	19.6	20.5	24	32	50	90	50	150	150	100	-	-	-	-
20AE052	E	50	40	47.7	24.8	26	30.8	41	60	110	60	200	200	100	-	-	-	-

(1) For IP 66 (NEMA / UL Type 4X/12) enclosures, drives listed as Frame A increase to Frame B and drives listed as Frame C increase to Frame D.

(2) Circuit Breaker - inverse time breaker. For US NEC, minimum size is 125% of motor FLA. Ratings that are shown are maximum.

(3) Motor Circuit Protector - instantaneous trip circuit breaker. For US NEC, minimum size is 125% of motor FLA. Ratings that are shown are maximum.

(4) Bulletin 140M with adjustable current range must have the current trip set to the minimum range that the device does not trip.

(5) Manual Self-Protected (Type E) Combination Motor Controller, UL Listed for 208 Wye or Delta, 240 Wye or Delta, 480Y/277 or 600Y/347. Not UL Listed for use on 480V or 600V Delta/Delta, corner ground, or high-resistance ground systems.

(6) Minimum protection device size is the lowest rated device that supplies maximum protection without nuisance tripping.

(7) Maximum protection device size is the highest rated device that supplies drive protection. For US NEC, minimum size is 125% of motor FLA. Ratings that are shown are maximum.

(8) Maximum allowable rating by US NEC. Exact size must be chosen for each installation.

(9) The AIC ratings of the Bulletin 140M Motor Protector Circuit Breakers can vary. See [Bulletin 140M Motor Protection Circuit Breakers Application ratings](#).

(10) When using a Manual Self-Protected (Type E) Combination Motor Controller, the drive must be installed in a ventilated or non-ventilated enclosure with the minimum volume that is specified in this column. Application-specific thermal considerations can require a larger enclosure.

# Mounting

This section includes information for mounting the drives.

## Maximum Surrounding Air Temperature

Enclosure Rating	Temperature Range
Open Type, IP 20, NEMA / UL Type 1 and flange mount	0...50 °C (32...122 °F)
IP 66, NEMA / UL Type 4X/12	0...40 °C (32...104 °F)
IP 54, NEMA / UL Type 12	0...40 °C (32...104 °F)

**IMPORTANT** Some drives are equipped with an adhesive label on the top of the chassis. Removing the adhesive label from the drive changes the enclosure rating from NEMA / UL Type 1 Enclosed to Type Open.

## Minimum Mounting Clearances

Specified vertical clearance requirements are intended to be from the drive to the closest object that can restrict airflow through the drive heatsink and chassis. The drive must be mounted in a vertical orientation as shown, and must make full contact with the mounting surface. Do not use standoffs or spacers. In addition, inlet air temperature must not exceed the product specification.

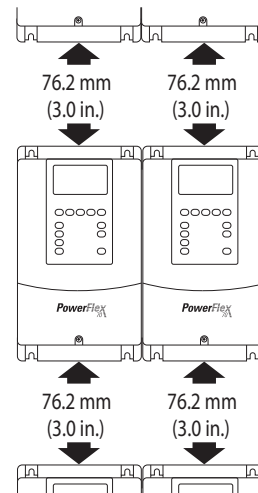

Clearances apply to all PowerFlex 70 Drives:

- Panel Mount
- Flange Mount
- NEMA Type 4X/12

## PowerFlex 70 Frames Output Power

Output Power		Frame Size							
kW ND (HD)	Hp ND (HD)	208...240V AC Input			400...480V AC Input			600V AC Input	
		Not Filtered	Filtered	IP66 (4X/12)	Not Filtered	Filtered	IP66 (4X/12)	Not Filtered	Filtered
0.37 (0.25)	0.5 (0.33)	A	B	B	A	B	B	A	-
0.75 (0.55)	1 (0.75)	A	B	B	A	B	B	A	-
1.5 (1.1)	2 (1.5)	B	B	B	A	B	B	A	-
2.2 (1.5)	3 (2)	B	B	B	B	B	B	B	-
4 (3)	5 (3)	-	C	D	B	B	B	B	-
5.5 (4)	7.5 (5)	-	D	D	-	C	D	C	-
7.5 (5.5)	10 (7.5)	-	D	D	-	C	D	C	-
11 (7.5)	15 (10)	-	D	D	-	D	D	D	-
15 (11)	20 (15)	-	E	E	-	D	D	D	-
18.5 (15)	25 (20)	-	E	E	-	D	D	-	-
22 (18.5)	30 (25)	-	-	-	-	D	D	-	-
30 (22)	40 (30)	-	-	-	-	E	E	-	-
37 (30)	50 (40)	-	-	-	-	E	E	-	-

# Approximate Dimensions and Weights

This section provides the approximate dimensions for the drives.

## Frames A...E

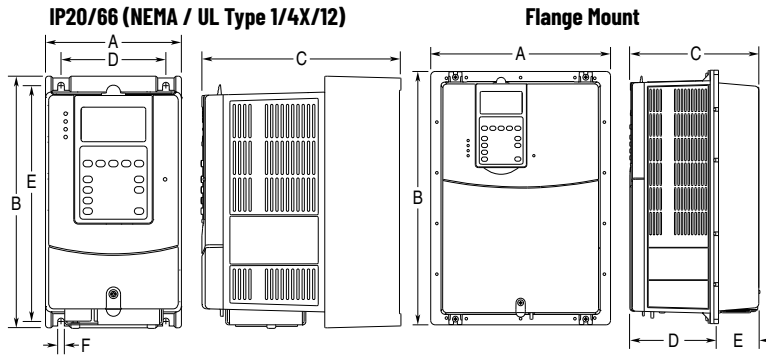

### Frame Dimensions, mm (in.)

Frame Size	Dimension						Weight <sup>(3)</sup> kg (lb)
	A	B	C	D	E	F	
<b>IP20, NEMA / UL Type 1</b>							
A	122.4 (4.82)	225.7 (8.89)	179.8 (7.08)	94.2 (3.71)	211.6 (8.33)	5.8 (0.23)	2.71 (6.0)
B	171.7 (6.76)	234.6 (9.24)	179.8 (7.08)	122.7 (4.83)	220.2 (8.67)	5.8 (0.23)	3.60 (7.9)
C	185.0 (7.28)	300.0 (11.81)	179.8 (7.08)	137.6 (5.42)	285.6 (11.25)	5.8 (0.23)	6.89 (15.2)
D	219.9 (8.66)	350.0 (13.78)	179.8 (7.08)	169.0 (6.65)	335.6 (13.21)	5.8 (0.23)	9.25 (20.4)
E <sup>(1)</sup>	280.3 (11.04)	555.8 (21.88)	207.1 (8.15)	200.0 (7.87)	491.0 (19.33)	6.9 (0.27)	18.60 (41.0) <sup>(1)</sup>
<b>IP66, NEMA / UL Type 4X/12</b>							
B	171.7 (6.76)	239.8 (9.44)	203.3 (8.00)	122.7 (4.83)	220.2 (8.67)	5.8 (0.23)	3.61 (8.0)
D	219.9 (8.66)	350.0 (13.78)	210.7 (8.29)	169.0 (6.65)	335.6 (13.21)	5.8 (0.23)	9.13 (20.1)
E <sup>(1)(2)</sup>	280.3 (11.04)	555.8 (21.88)	219.8 (8.65)	200.0 (7.87)	491.0 (19.33)	6.9 (0.27)	18.60 (41.0) <sup>(1)</sup>
<b>Flange Mount</b>							
A	156.0 (6.14)	225.8 (8.89)	178.6 (7.03)	123.0 (4.84)	55.6 (2.19)	-	2.71 (6.0)
B	205.2 (8.08)	234.6 (9.24)	178.6 (7.03)	123.0 (4.84)	55.6 (2.19)	-	3.60 (7.9)
C	219.0 (8.62)	300.0 (11.81)	178.6 (7.03)	123.0 (4.84)	55.6 (2.19)	-	6.89 (15.2)
D	248.4 (9.78)	350.0 (13.78)	178.6 (7.03)	123.0 (4.84)	55.6 (2.19)	-	9.25 (20.4)
E	280.3 (11.04)	555.8 (21.88)	207.1 (8.15)	117.2 (4.61)	89.9 (3.54)	-	18.60 (41.0)

(1) IP20 and IP66 frame E drives are manufactured with a flange-like heatsink with mounting holes.

(2) Frame E is also available in IP54 NEMA/UL Type 12 as a wall/machine mount.

(3) Weights include HIM and standard I/O.

## IP20, NEMA / UL Type 1 Bottom View Dimensions, mm (in.)

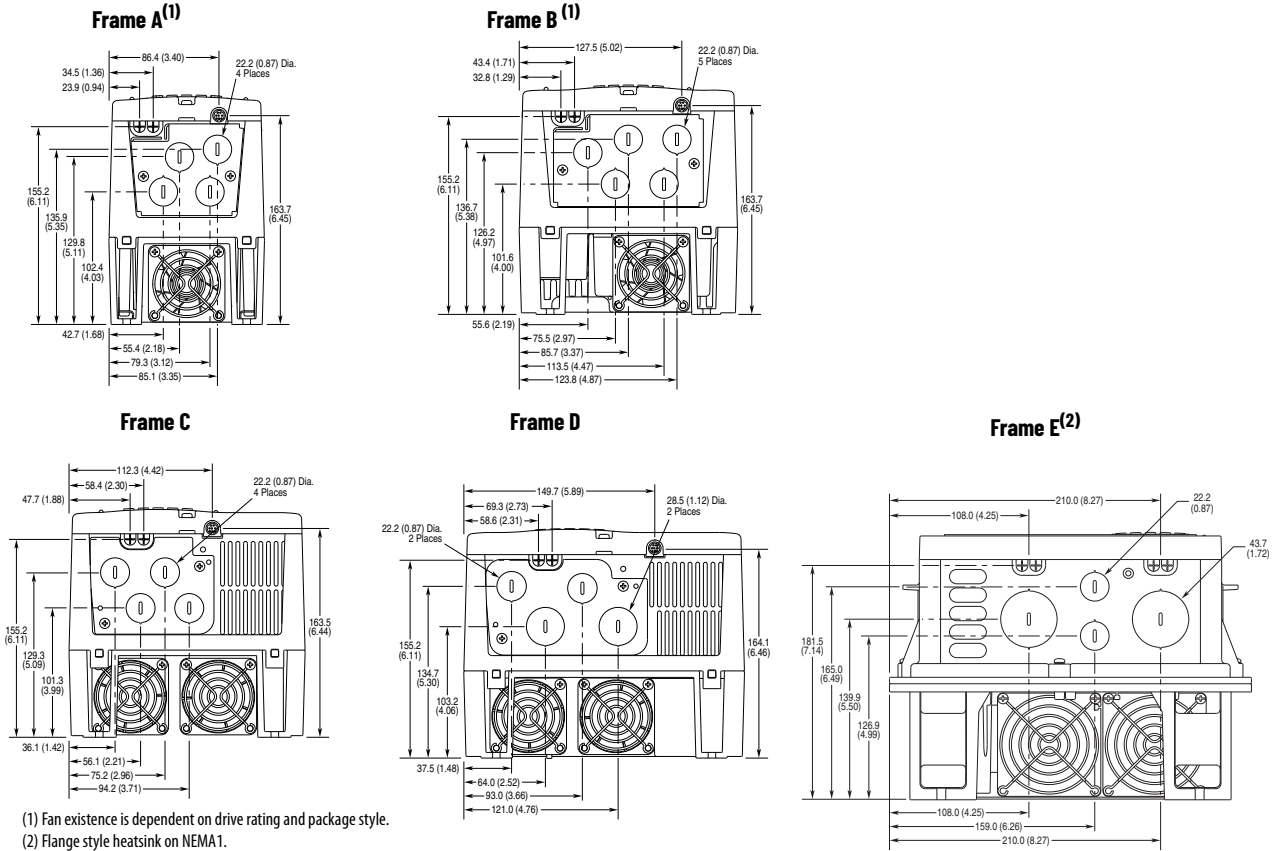

## IP 66 (NEMA / UL Type 4X/12) Bottom View Dimensions, mm (in.)

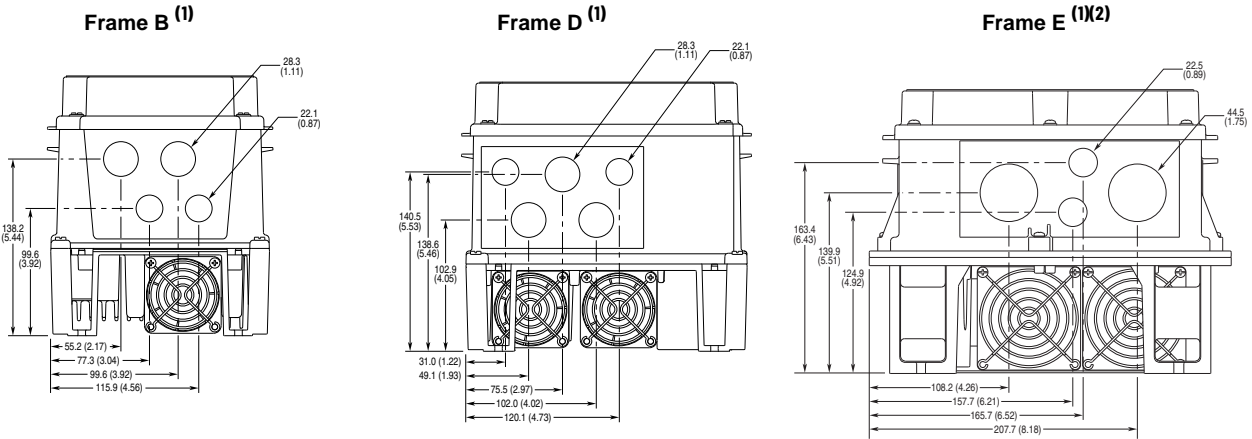

**Flange Mount Bottom View Dimensions, mm (in.)**

**Frame A**

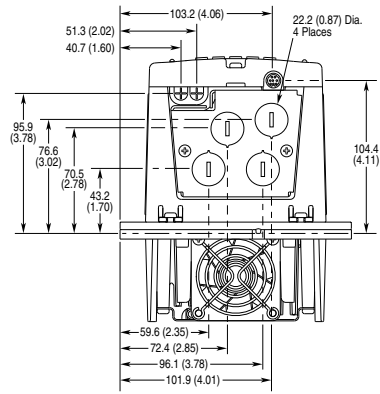

**Frame C**

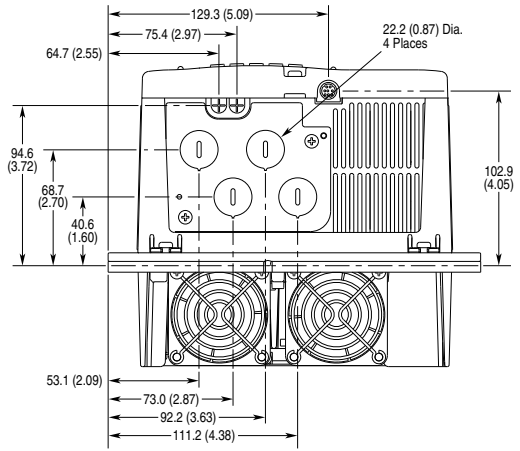

**Frame B**

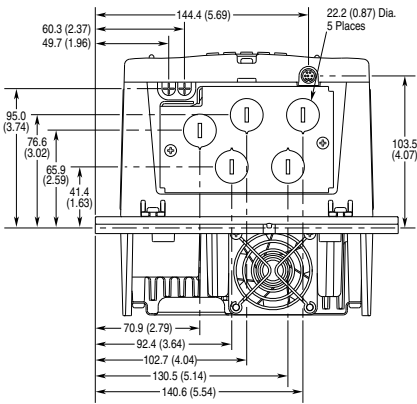

**Frame D**

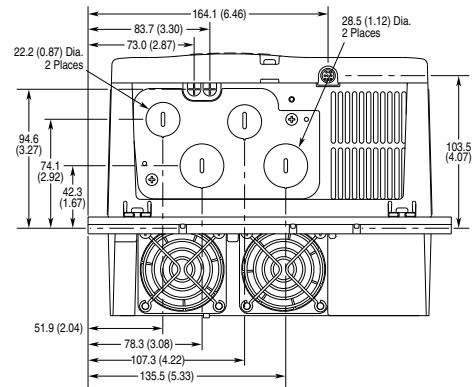

**Frame E**

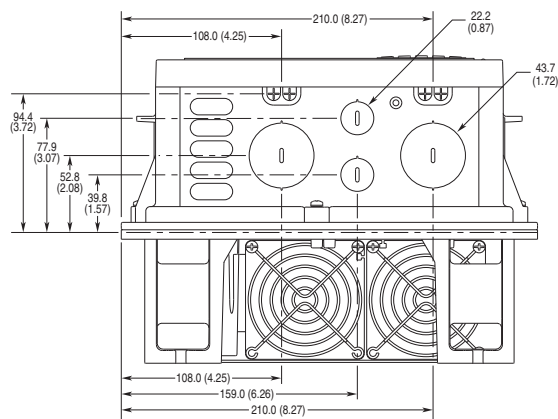

Cutout Dimensions, mm (in.)

Frame A

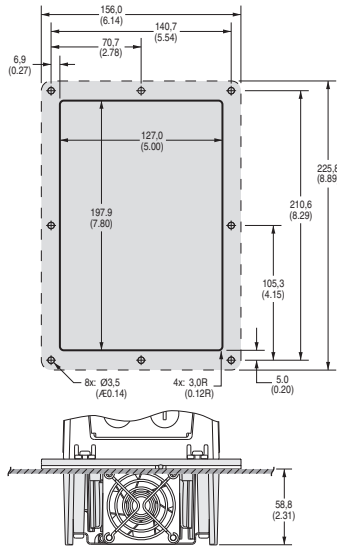

Frame C

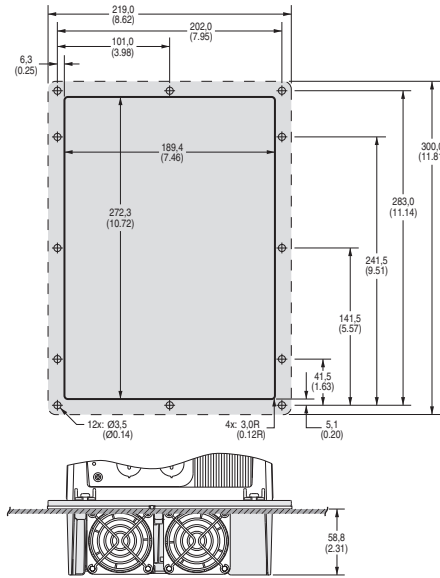

Frame B

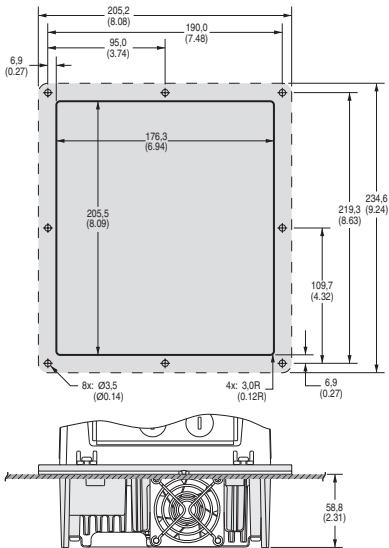

Frame D

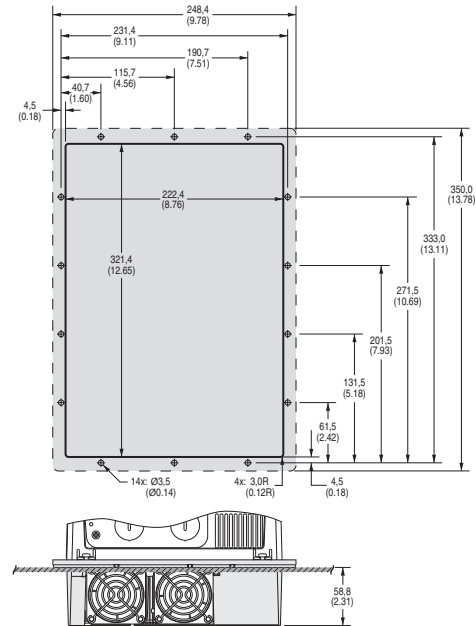

Cutout Dimensions, mm (in.) (continued)

Frame E

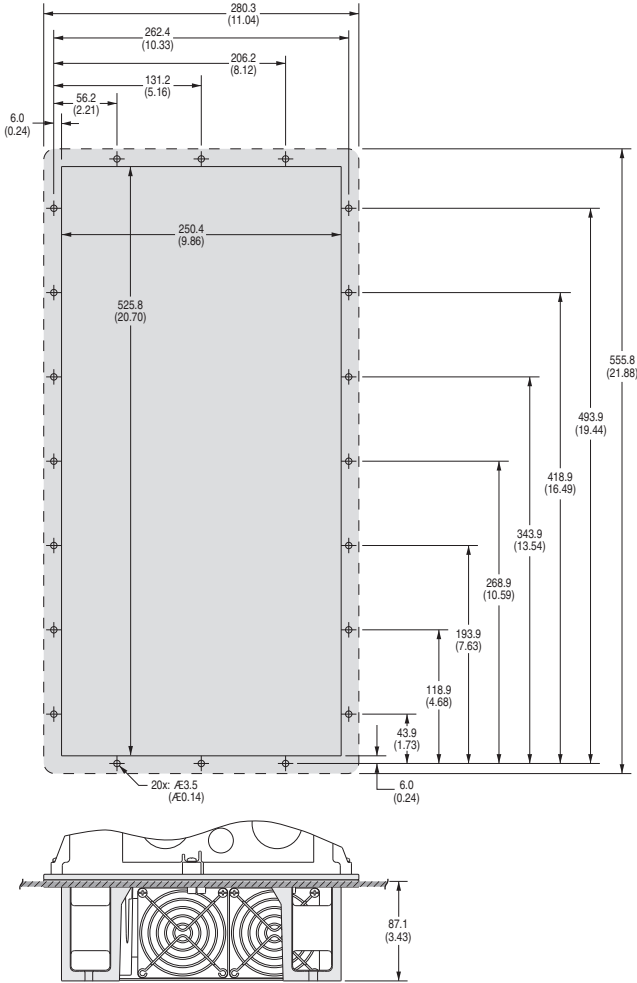

# PowerFlex 70 Configured Drives

You can use the PowerFlex 70 packaged drives program to create drive packages that are based on your specific needs. This program enhances standalone drive functionality through additional control, power, and packaging options that are ideal for original equipment manufacturers (OEM) and customers with special installation needs.

## Catalog-configured Drives Program

You can use the catalog configured drives program to create drive packages that are based on your specific needs. You can specify a complete drive package by assembling a single catalog number string that includes a base drive and all required options. Packaging is available for 480V requirements in NEMA Type 1 (IP20), NEMA 4/12 (IP65) indoor, and NEMA 3/4 (IP65) outdoor ratings. Focused on higher volume, repeat business, the standard designs provide consistent manufacturing and minimizes customer resources by reducing engineering, manufacturing, and installation time.

### NEMA Type 1 NEMA Type 4/12 Indoor NEMA Type 3/4 Outdoor

- Enhanced control
- Flange mount drive
- Welded construction
- 480V rating

### All Enclosure Types

- Drive input protection options
- Input/Output contactors
- Bypass options
- Input/Output line reactor options
- 115V control power options
- Control interface and feedback options
- Human interface modules
- Motor interface options
- Operator devices
- Drawing and test options



## Approximate Dimensions

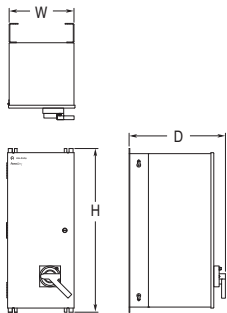

Figure 1

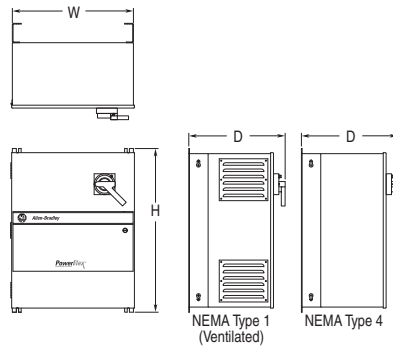

Figure 2

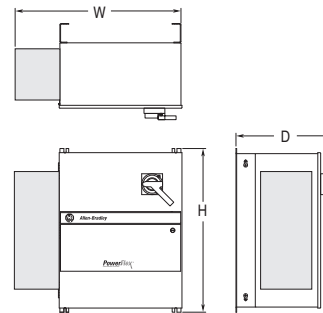

Figure 3

## Maximum Enclosure Dimensions

Ratings		Drive Frame Size	Power Flex 70 Flange Drive Cat. No.	Enclosure Style for Flange Mounted Drives															
ND Hp	HD Hp			NEMA Type 1, Option Code A				NEMA Type 4 Indoor, Option Code D NEMA Type 12 Indoor, Option Code G						NEMA Type 3/4, Option Code E					
				BO, C1, C5, S1, S9...S13, S16, P1...P3, Drive Mounted Options and All HIMs		All Options		BO, C1, C5, S1, S9...S13, S16, P1...P3, Drive Mounted Options and All NEMA 4 HIMs		All Options Less Line Reactor		All Options		BO, C1, C5, S1, S9...S13, S16, P1...P3, Drive Mounted Options		All Options Less Line Reactor		All Options	
Figure	Style	Figure	Style	Figure	Style	Figure	Style	Figure	Style	Figure	Style	Figure	Style	Figure	Style	Figure	Style	Figure	Style
<b>480V AC, Three-phase Drives</b>																			
0.5	0.33	A	D1P1	1	1	2	3	1	1	2	3	2	3	1	1	2	3	2	3
1.0	0.75	A	D2P1	1	1	2	3	1	1	2	3	2	3	1	1	2	3	2	3
2.0	1.5	A	D3P4	1	1	2	3	1	1	2	3	2	3	1	1	2	3	2	4
3.0	2.0	B	D5P0	1	1	2	3	1	1	2	3	2	4	1	1	2	3	2	5
5.0	3.0	B	D8P0	1	1	2	3	1	1	2	3	2	4	1	1	2	3	2	5
7.5	5.0	C	D011	1	1	2	3	1	1	2	3	2	4	1	1	2	3	2	5
10	7.5	C	D014	1	1	2	3	1	1	2	3	2	4	1	1	2	3	2 or 3 <sup>(1)</sup>	5 or 8 <sup>(1)</sup>
15	10	D	D022	1	1	2	4	1	1	2	4	2	5	16	1	2	4	2 or 3 <sup>(1)</sup>	5 or 8 <sup>(1)</sup>
20	15	D	D027	1	1	2	4	1	1	2	4	2	5	1	1	2	4	3	8
25	20	D	D034	1	1	2	4	1	1	2	4	2	5	1	1	2	5	3	8
30	25	D	D040	1	1	2	4	1	1	2	4	2	5	1	1	2	5	3	8
40	30	E	D052	1	2	2	6	1	2	2	6	2	7	1	2	2	6	3	9
50	40	E	D065	1	2	2	6	1	2	2	6	2	7	1	2	2	6	3	9

(1) Figure 2, Style 5, when one line reactor is selected. Figure 3, Style 8, when two line reactors are selected

## Enclosure Dimensions

Figure	Style	Enclosure Rating	Option Code (Position d)	Dimensions <sup>(1)</sup>	
				H x W x D (mm)	H x W x D (in.)
1	1	NEMA 1	A	812.8 x 330.2 x 484.1	32 x 13 x 19.06
1	2	NEMA 1	A	1,270.0 x 406.4 x 484.1	50 x 16 x 19.06
2	3	NEMA 1	A	812.8 x 609.6 x 484.1	32 x 24 x 19.06
2	4	NEMA 1	A	965.2 x 609.6 x 484.1	38 x 24 x 19.06
2	6	NEMA 1	A	1,270.0 x 762.0 x 484.1	50 x 30 x 19.06
1	1	NEMA 4/12 Indoor, NEMA 4 Outdoor	D, G, E	812.8 x 330.2 x 484.1	32 x 13 x 19.06
1	2	NEMA 4/12 Indoor, NEMA 4 Outdoor	D, G, E	1,270.0 x 406.4 x 484.1	50 x 16 x 19.06
2	3	NEMA 4/12 Indoor, NEMA 4 Outdoor	D, G, E	812.8 x 609.6 x 484.1	32 x 24 x 19.06
2	4	NEMA 4/12 Indoor, NEMA 4 Outdoor	D, G, E	965.2 x 609.6 x 484.1	38 x 24 x 19.06
2	5	NEMA 4/12 Indoor, NEMA 4 Outdoor	D, G, E	1,270.0 x 609.6 x 484.1	50 x 24 x 19.06
2	6	NEMA 4/12 Indoor, NEMA 4 Outdoor	D, G, E	1,270.0 x 762.0 x 484.1	50 x 30 x 19.06
2	7	NEMA 4/12 Indoor, NEMA 4 Outdoor	D, G, E	1,270.0 x 914.4 x 484.1	50 x 36 x 19.06
3	8	NEMA 4/12 Indoor, NEMA 4 Outdoor	D, G, E	812.8 x 831.9 x 484.1	50 x 32.75 x 19.06
3	9	NEMA 4/12 Indoor, NEMA 4 Outdoor	D, G, E	1,270.0 x 984.3 x 484.1	50 x 38.75 x 19.06

(1) Depth includes 6.35 mm (2.5 in) for operator handle, if ordered.

# Standard Drive Certifications and Specifications

The tables in this section provide certification information and technical specifications.

## Certifications<sup>(1)</sup>

Certifications <sup>(2)</sup>	Description	Frames	
		A...E 240...480V	A...E 600V
<b>ABS</b>	American Bureau of Shipping MA Certificate 08-HS303172A-3-PDA for auxiliary services on AB Classed vessels and offshore platforms	X	X
<b>RCM</b>	Certified by Rockwell Automation to be in conformity with the requirements of the applicable Australian legislation and standards that are referenced here: IEC 61800-3	X	
<b>c-UL-us</b>	Listed to UL508C and CAN/CSA C22.2 No. 274-13 Configured drives can be listed to UL508A	X	X
<b>CE</b>	Certified by Rockwell Automation to be in conformity with the essential requirements of the applicable European Directives. The following standards have been applied:	—	—
	<b>2014/35/EU (Low Voltage Directive)</b> EN 61800-5-1 Electronic Equipment for Use in Power Installations	X	X
	<b>2014/30/EU (EMC Directive)</b> EN 61800-3 Adjustable speed electrical power drive systems - Part 3: EMC requirements and specific test methods	X	
<b>EAC</b>	Low Voltage TR CU 004/2011 EMC TR CU 020/2011	X	X
<b>EPRI/SEMIF 47</b>	EPRI Quality Star Certificates SEMIF47.116 for SEMI F47 compliance, only 480V units tested	X	
<b>Functional Safety</b>	TÜV Rheinland Certificate 01/205/0665.01/15 Safe Torque Off (STO) complies with the requirements of the relevant standards (Cat. 3 / PLd according to EN ISO 13849-1, SIL CL 2 according to EN ISO 13849-1, and SIL 2 according to EN 62061 / IEC 61508.	X	
<b>Korean KC Registration</b>	<b>KCC-REM-RAA-20A</b> See the certificate of registration for specific drive catalog numbers that have this certification. <sup>(2)</sup>	X	X
<b>Lloyd's Register</b>	Lloyd's Register Type Approval Certificate 08/60014 (E1) (marine certification)	X	
<b>Plenum Rating</b>	Listed to UL508C Suitable for installation in a compartment handling conditioned air. <sup>(3)</sup>		
<b>Trentec</b>	Tested by Trentec to be compliant with AC156 Acceptance Criteria for Seismic Qualification Testing of Nonstructural Components and 2003 International Building Code for worst-case seismic level for USA excluding site class F	X	X
<b>Designed to Meet Applicable Requirements</b>	IEC 61800-2 - Adjustable speed electrical power drive systems - Part 2: General requirements - Rating specifications for low voltage adjustable frequency AC power drive systems	X	X
	NEMA ICS 7.1 - Safety Standards for Construction and Guide for Selection, Installation, and Operation of Adjustable Speed Drive Systems	X	X
	NFPA 70 - US National Electric Code	X	X
	NSF - Type 4X enclosure NSF Listed to meet Criteria C2 for splash and non-food zones	X	X

(1) See the Rockwell Automation Product Certification page for current certifications, <http://www.rockwellautomation.com/global/certification/overview.page>

(2) See the product certifications website, <http://www.rockwellautomation.com/products/certification/> for declarations of conformity, certificates, and other certification details.

(3) Flange mount enclosure, Frames A...D only.

## Specifications

Category	Specification							
	<b>Drive</b>	<b>200...208V</b>	<b>240V</b>	<b>380/400</b>	<b>480V</b>	<b>600V</b>	<b>690V</b>	
	AC input overvoltage trip	247V AC	285V AC	475V AC	570V AC	690V AC		
	AC input undervoltage trip	120V AC	138V AC	233V AC	280V AC	345V AC		
	Bus overvoltage trip	405V DC	405V DC	810V DC	810V DC	1013V DC		
	Bus undervoltage output shutoff	153V DC	153V DC	305V DC	437V DC	437V DC		
	Bus undervoltage fault level	160V DC	160V DC	300V DC	300V DC	375V DC		
	Bus voltage nom	281V DC	324V DC	540V DC	648V DC	810V DC		
	All Drives							
	<b>Protection</b>	Heatsink thermistor	Monitored by microprocessor overtemp trip					
		Drive overcurrent trip:	<ul style="list-style-type: none"> <li>• Software current limit</li> <li>• Hardware current limit</li> <li>• Instantaneous current limit</li> </ul>					
		<ul style="list-style-type: none"> <li>• 20...160% of rated current</li> <li>• 200% of rated current (typical)</li> <li>• 220...300% of rated current (dependent on drive rating)</li> </ul>						
Line transients		Up to 6000 volts peaks per IEEE C62.41-1991						
Control logic noise immunity		Showering arc transients up to 1500V peak						
Power ride-through		15 ms at full load						
Logic control ride-through		0.5 s min, 2 s typ						
Ground fault trip		Phase-to-ground on drive output						
Short circuit trip		Phase-to-phase on drive output						
<b>Environment</b>		Altitude	1000 m (3300 ft) max without derating					
	Maximum surrounding air temperature without derating:	<ul style="list-style-type: none"> <li>• IP20, NEMA / UL Type 1</li> <li>• flange mount</li> <li>• IP66, NEMA / UL Type 4X/12 (indoor)</li> </ul>						
		<ul style="list-style-type: none"> <li>• 0...50 °C (32...122 °F)</li> <li>• 0...50 °C (32...122 °F)</li> <li>• 0...40 °C (32...104 °F)</li> </ul>						
	Cooling fan operation:	<ul style="list-style-type: none"> <li>• Frames A and C</li> <li>• Frames B, D, and E</li> </ul>						
		<ul style="list-style-type: none"> <li>• Fan operates when power is applied.</li> <li>• Fan operates when power is applied and in Run condition.</li> </ul>						
	Storage temperature (all const.)	-40...+70 °C (-40...+158 °F)						
	Atmosphere	<b>Important:</b> Drive <b>must not</b> be installed in an area where the ambient atmosphere contains volatile or corrosive gas, vapors, or dust. If the drive is not going to be installed immediately, store the drive where it is not exposed to a corrosive atmosphere.						
	Relative humidity	5...95% non-condensing						
	Shock	15 g peak for 11 ms duration (±1.0 ms)						
	Vibration	0.152 mm (0.006 in.) displacement, 1 g peak						
	Pollution degree of the surrounding environment:	<ul style="list-style-type: none"> <li>• Pollution degree 1 and 2</li> <li>• Pollution degree 3 and 4</li> </ul> See <a href="#">Pollution Degree Ratings According to EN 61800-5-1</a> for descriptions of pollution degree rating.						
		<ul style="list-style-type: none"> <li>• All enclosures are acceptable for pollution degree 1 and 2.</li> <li>• An enclosure that meets or exceeds IP54, NEMA / UL Type 12, is required for pollution degree 3 and 4.</li> </ul>						

## Pollution Degree Ratings According to EN 61800-5-1

Pollution Degree	Description
1	One of the following is true: <ul style="list-style-type: none"> <li>• No pollution occurs.</li> <li>• Only dry non-conductive pollution occurs, and has no influence.</li> </ul>
2	Normally only non-conductive pollution occurs. Occasionally a temporary conductivity, caused by condensation, is expected when the drive is out of operation.
3	At least one of the following is true: <ul style="list-style-type: none"> <li>• Conductive pollution occurs.</li> <li>• Dry non-conductive pollution occurs and becomes conductive due to condensation.</li> </ul>
4	The pollution generates persistent conductivity that is caused, for example, by conductive dust, rain, or snow.

## Specifications

Category	Specification		
Electrical	Voltage tolerance	-10% of minimum, +10% of maximum. See the PowerFlex 70 Adjustable Frequency AC Drives User Manual, <a href="#">publication 20A-UM001</a> , for Full Power and Operating Range.	
	Input frequency tolerance	47...63 Hz	
	Input phases	Three-phase input provides full rating for all drives. Single-phase operation provides 50% of rated current.	
	Displacement power factor (all drives)	0.98 across speed range.	
	Efficiency	97.5% at rated amps, line volts nom.	
	Short circuit rating max	200,000 amps symmetrical.	
	Short circuit current rating max (by using the recommended fuse or circuit breaker type)	Maximum short circuit current rating to match specified fuse/circuit breaker capability.	
	Drive to motor power ratio: <ul style="list-style-type: none"> <li>Minimum</li> <li>Maximum</li> </ul>	<ul style="list-style-type: none"> <li>Recommended not less than 1:2 ratio</li> <li>Recommended not greater than 2:1 ratio</li> </ul>	
Control	Method	Sine coded PWM with programmable carrier frequency. Ratings apply to all drives.	
	Carrier frequency	2, 3, 4, 5, 6, 7, 8, 9, and 10 kHz <b>Standard</b> . 2, 4, 8, and 12 kHz <b>EC</b> . Drive rating based on 4 kHz.	
	Output voltage range	0 to rated motor voltage	
	Output frequency range	0...400 Hz <b>Standard</b> . 0...500 Hz <b>EC</b> .	
	Frequency accuracy: <ul style="list-style-type: none"> <li>Digital input</li> <li>Analog input</li> </ul>	<ul style="list-style-type: none"> <li>Within <math>\pm 0.01\%</math> of set output frequency.</li> <li>Within <math>\pm 0.4\%</math> of maximum output frequency.</li> </ul>	
	Frequency control - speed regulation	with slip compensation (Volts per Hertz mode)	0.5% of base speed across 40:1 speed range 40:1 operating range 10 rad/sec bandwidth
		with slip compensation (Sensorless Vector mode)	0.5% of base speed across 80:1 speed range 80:1 operating range 20 rad/sec bandwidth
		with feedback (Sensorless Vector mode) <b>EC</b>	0.001% of base speed across 40:1 speed range 0.1% of base speed across 80:1 speed range 80:1 operating range 20 rad/sec bandwidth
	Speed control - speed regulation	without feedback (Vector Control mode) <b>EC</b>	0.1% of base speed across 120:1 speed range 120:1 operating range 30 rad/sec bandwidth
		with feedback (Vector Control mode) <b>EC</b>	0.001% of base speed across 120:1 speed range 1000:1 operating range 125 rad/sec bandwidth
	Torque regulation	without feedback +/-10% <b>EC</b>	
		with feedback +/-5% <b>EC</b>	
	Selectable motor control	Sensorless Vector with full tuning. Standard VHz with full custom capability and vector control.	
Stop modes	Multiple programmable stop modes including - Ramp, Coast, DC-Brake, Fast Brake, Ramp to Hold, and S-curve.		
Accel/Decel	Two independently programmable accel and decel times. Each time can be programmed from 0...3600 seconds in 0.1 second increments		
Intermittent overload	110% Overload capability for up to 1 minute 150% Overload capability for up to 3 seconds		
Current limit capability	Proactive current limit programmable from 20...160% of rated output current. Independently programmable proportional and integral gain.		
Motor overload protection	Class 10 motor overload protection according to NEC article 430 and motor over-temperature protection according to NEC article 430.126 (A)(2). UL 508C File E59272.		

## Specifications (Continued)

Category	Specification	
Encoder	Type	Incremental, dual channel
	Supply	5V/12V Configurable $\pm 5\%$
	Quadrature	$90^\circ \pm 27^\circ$
	Duty cycle	50% $\pm 10\%$
	Requirements <sup>(1)</sup>	Encoders must be line driver type, quadrature (dual-channel), or pulse (single-channel), single-ended or differential and capable of supplying 10 mA min per channel. The encoder interface board accepts 5V or 12V DC square-wave with a high state voltage of 3.5V DC min (5V mode), and 7.0V DC min (12V mode). Low state voltage max is 1V DC (for both 5V and 12V modes). Input frequency max is 250 kHz.

(1) Drive is not CE EMC certified when the encoder interface option is installed.

## Watts Loss (rated load, speed, and PWM) <sup>(1)</sup>

Voltage	ND Hp	External Watts	Internal Watts	Total Watts Loss
208V	0.5	12.2	19.2	31.4
	1.0	30.7	20.5	51.2
	2.0	44.6	22.6	67.2
	3.0	67.3	25.4	92.7
	5.0	141.3	33.2	174.5
	7.5	205.7	34.2	239.9
	10	270.4	48.1	318.5
	15	385.6	40.3	425.9
	20	494.6	44.9	539.5
	25	650.7	51.6	702.3
240V	0.5	12.2	19.2	31.4
	1.0	30.7	20.5	51.2
	2.0	44.6	22.6	67.2
	3.0	67.3	25.4	92.7
	5.0	141.3	33.2	174.5
	7.5	205.7	34.2	239.9
	10	270.4	48.1	318.5
	15	385.6	40.3	425.9
	20	494.6	44.9	539.5
	25	650.7	51.6	702.3
400V	0.37	11.5	17.9	29.4
	0.75	27.8	19.5	47.3
	1.5	43.6	21.6	65.2
	2.2	64.6	24.0	88.6
	4.0	99.5	28.2	127.7
	5.5	140.0	27.8	167.8
	7.5	193.3	32.0	225.3
	11	305.4	34.2	339.6
	15	432.9	42.9	475.8
	18.5	363.8	40.5	404.3
	22	396.8	41.5	438.3
	30	500.8	50.0	550.8
	37	632.0	57.7	689.7
480V	0.5	11.5	17.9	29.4
	1.0	27.8	19.5	47.3
	2.0	43.6	21.6	65.2
	3.0	64.6	24.0	88.6
	5.0	99.5	28.2	127.7
	7.5	140.0	27.8	167.8
	10	193.3	32.0	225.3
	15	305.4	34.2	339.6
	20	432.9	42.9	475.8
	25	363.8	40.5	404.3
	30	396.8	41.5	438.3
	40	500.8	50.0	550.8
	50	632.0	57.7	689.7
600V	0.5	11.5	17.9	29.4
	1.0	27.8	19.5	47.3
	2.0	43.6	21.6	65.2
	3.0	64.6	24.0	88.6
	5.0	99.5	28.2	127.7
	7.5	140.0	27.8	167.8
	10	193.3	32.0	225.3
	15	305.4	34.2	339.6
	20	432.9	42.9	475.8
	25	281.4	42.4	323.8
	30	311.9	43.4	355.3
	40	389.9	51.8	441.7
	50	501.4	59.9	561.3

(1) Worst case condition including Enhanced Control board, HIM, and Communication Module.

## Voltage Tolerance

This section provides information to help you determine the voltage tolerance for your drive installation.

### Voltage Tolerance<sup>(1)</sup>

Drive Rating	Line Voltage nom	Motor Voltage nom	Drive Full Power Range	Drive Operating Range
200...240	200	200 <sup>(2)</sup>	200...264	180...264
	208	208	208...264	
	240	230	230...264	
380...480	380	380 <sup>(2)</sup>	380...528	342...528
	400	400	400...528	
	480	460	460...528	
500...600	600	575 <sup>(2)</sup>	575...660	432...660

(1) Drive full power range = Nominal motor voltage to drive rated voltage +10%. Rated current is available across the entire drive full power range.

(2) Drive operating range = Lowest nominal motor voltage -10% to drive rated voltage +10%. Drive output is linearly derated when actual line voltage is less than the nominal motor voltage.

### EXAMPLE:

Calculate the maximum power of a 5 Hp, 460V motor connected to a 480V rated drive supplied with 342V actual line voltage input.

- Actual Line Voltage / Nominal Motor Voltage = 74.3%
- $74.3\% \times 5 \text{ Hp} = 3.7 \text{ Hp}$
- $74.3\% \times 60 \text{ Hz} = 44.6 \text{ Hz}$

At 342V actual line voltage, the maximum power the 5 Hp, 460V motor can produce is 3.7 Hp at 44.6 Hz.

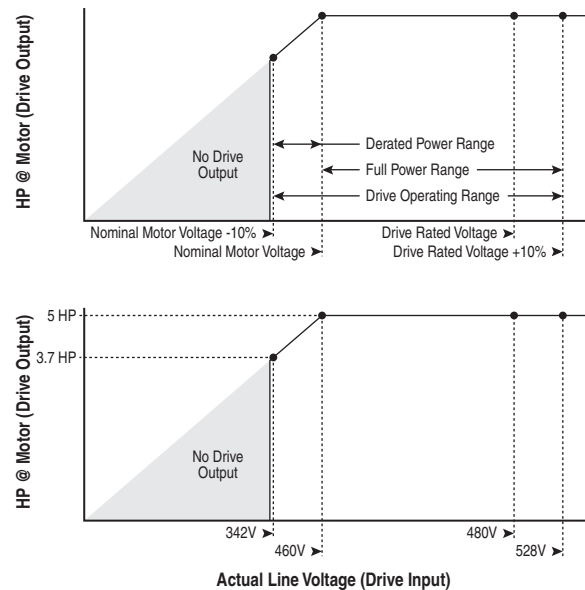

# Derating Guidelines

Follow these guidelines for derating your drive installation.

## Altitude and Efficiency

Frame	Type	Derate																																	
All	Altitude	<table border="1"> <caption>% of Drive Rated Amps vs. Altitude (m)</caption> <thead> <tr> <th>Altitude (m)</th> <th>% of Drive Rated Amps</th> </tr> </thead> <tbody> <tr><td>0</td><td>100%</td></tr> <tr><td>1,000</td><td>100%</td></tr> <tr><td>2,000</td><td>94%</td></tr> <tr><td>3,000</td><td>88%</td></tr> <tr><td>4,000</td><td>82%</td></tr> <tr><td>5,000</td><td>76%</td></tr> <tr><td>6,000</td><td>70%</td></tr> </tbody> </table>	Altitude (m)	% of Drive Rated Amps	0	100%	1,000	100%	2,000	94%	3,000	88%	4,000	82%	5,000	76%	6,000	70%																	
	Altitude (m)	% of Drive Rated Amps																																	
0	100%																																		
1,000	100%																																		
2,000	94%																																		
3,000	88%																																		
4,000	82%																																		
5,000	76%																																		
6,000	70%																																		
	Efficiency (typical)	<table border="1"> <caption>% Efficiency vs. % Speed/% Load</caption> <thead> <tr> <th>% Speed/% Load</th> <th>% Efficiency (vs. Speed)</th> <th>% Efficiency (vs. Load)</th> </tr> </thead> <tbody> <tr><td>10</td><td>96%</td><td>84%</td></tr> <tr><td>20</td><td>97%</td><td>91%</td></tr> <tr><td>30</td><td>97.5%</td><td>94%</td></tr> <tr><td>40</td><td>97.8%</td><td>95.5%</td></tr> <tr><td>50</td><td>98%</td><td>96.5%</td></tr> <tr><td>60</td><td>98.1%</td><td>97%</td></tr> <tr><td>70</td><td>98.2%</td><td>97.3%</td></tr> <tr><td>80</td><td>98.3%</td><td>97.5%</td></tr> <tr><td>90</td><td>98.4%</td><td>97.7%</td></tr> <tr><td>100</td><td>98.5%</td><td>97.8%</td></tr> </tbody> </table>	% Speed/% Load	% Efficiency (vs. Speed)	% Efficiency (vs. Load)	10	96%	84%	20	97%	91%	30	97.5%	94%	40	97.8%	95.5%	50	98%	96.5%	60	98.1%	97%	70	98.2%	97.3%	80	98.3%	97.5%	90	98.4%	97.7%	100	98.5%	97.8%
% Speed/% Load	% Efficiency (vs. Speed)	% Efficiency (vs. Load)																																	
10	96%	84%																																	
20	97%	91%																																	
30	97.5%	94%																																	
40	97.8%	95.5%																																	
50	98%	96.5%																																	
60	98.1%	97%																																	
70	98.2%	97.3%																																	
80	98.3%	97.5%																																	
90	98.4%	97.7%																																	
100	98.5%	97.8%																																	

# Ambient Temperature/Load

## 240V AC

PowerFlex 70 Power Rating		Derating
ND Hp	HD Hp	
240 Volts		
0.5...3.0	0.33...2.0	None
5.0	3.0	
7.5	5.0	
10	7.5	
15	10	
20	15	
25	20	

# 400V AC

PowerFlex 70 Power Rating		Derating
ND kW	HD kW	
400 Volts		
0.37...5.5	0.25...4.0	None
7.5	5.5	
11	7.5	
15	11	
18.5	15	

## 400V AC (Continued)

PowerFlex 70 Power Rating		Derating
ND kW	HD kW	
400 Volts		
22	18.5	
30	22	
37	30	

## 480V AC

PowerFlex 70 Power Rating		Derating
ND Hp	HD Hp	
480 Volts		
0.5...7.5	0.33...5.0	None
10	7.5	
15	10	
20	15	

## 480V AC (Continued)

PowerFlex 70 Power Rating		Derating
ND Hp	HD Hp	
<b>480 Volts</b>		
25	20	
30	25	
40	30	
50	40	

## 600V AC

PowerFlex 70 Power Rating		Derating
ND Hp	HD Hp	
<b>600 Volts</b>		
0.5...5.0	0.33...3.0	None
7.5	5.0	
10	7.5	

600V AC (Continued)

PowerFlex 70 Power Rating		Derating
ND Hp	HD Hp	
600 Volts		
15	10	<p>Derating graph for 15 ND Hp / 10 HD Hp at 600V AC. The y-axis is Max Ambient Temp (°C) from 20 to 50. The x-axis is % of Rated Continuous Current from 40 to 100. The 10 kHz curve (solid black) starts at 50°C at 50% current and derates to ~23°C at 100% current. The 8 kHz curve (dashed orange) starts at 50°C at 70% current and derates to ~38°C at 100% current. Other frequencies (2, 4, 6 kHz) are constant at 50°C.</p>
20	15	<p>Derating graph for 20 ND Hp / 15 HD Hp at 600V AC. The y-axis is Max Ambient Temp (°C) from 20 to 50. The x-axis is % of Rated Continuous Current from 40 to 100. The 10 kHz curve (solid black) starts at 50°C at 50% current and derates to ~20°C at 100% current. The 8 kHz curve (dashed orange) starts at 50°C at 65% current and derates to ~33°C at 100% current. The 6 kHz curve (solid green) starts at 50°C at 80% current and derates to ~45°C at 100% current. Other frequencies (2, 4 kHz) are constant at 50°C.</p>
25	20	<p>Derating graph for 25 ND Hp / 20 HD Hp at 600V AC. The y-axis is Max Ambient Temp (°C) from 20 to 50. The x-axis is % of Rated Continuous Current from 40 to 100. All curves (2, 4, 6, 8, 10 kHz) are constant at 50°C until 90% current, then derate to ~45°C at 100% current.</p>
30	25	<p>Derating graph for 30 ND Hp / 25 HD Hp at 600V AC. The y-axis is Max Ambient Temp (°C) from 20 to 50. The x-axis is % of Rated Continuous Current from 40 to 100. The 10 kHz curve (solid black) starts at 50°C at 70% current and derates to ~20°C at 100% current. The 8 kHz curve (dashed orange) starts at 50°C at 80% current and derates to ~25°C at 100% current. The 6 kHz curve (solid green) starts at 50°C at 90% current and derates to ~38°C at 100% current. Other frequencies (2, 4 kHz) are constant at 50°C.</p>
40	30	<p>Derating graph for 40 ND Hp / 30 HD Hp at 600V AC. The y-axis is Max Ambient Temp (°C) from 20 to 50. The x-axis is % of Rated Continuous Current from 40 to 100. All curves (2, 4, 6, 8, 10 kHz) are constant at 50°C until 90% current, then derate to ~40°C at 100% current.</p>
50	40	<p>Derating graph for 50 ND Hp / 40 HD Hp at 600V AC. The y-axis is Max Ambient Temp (°C) from 20 to 50. The x-axis is % of Rated Continuous Current from 40 to 100. All curves (2, 4, 6, 8, 10 kHz) are constant at 50°C until 90% current, then derate to ~40°C at 100% current.</p>

## Additional Resources

These documents contain additional information concerning related products from Rockwell Automation.

Resource	Description
Preventive Maintenance of Industrial Control and Drive System Equipment, publication <a href="#">DRIVES-TD001</a>	Provides a guide to performing preventive maintenance.
PowerFlex 70 Adjustable Frequency AC Drive User Manual, publication <a href="#">20A-UM001</a>	Provides the basic information that is needed to start up and troubleshoot the PowerFlex® 70 Adjustable Frequency AC Drive.
PowerFlex 70 EC and 700 VC Reference Manual, publication <a href="#">PFLEX-RM004</a>	Provides detailed drive information including operation, parameter descriptions, and programming.
PowerFlex 70 and 700 Adjustable Frequency AC drives Reference Manual, publication <a href="#">PFLEX-RM001</a>	Provides detailed information for specifications and dimensions, operation, and dynamic brake selection for the drive.
PowerFlex 70 Adjustable Frequency AC Drive Installation Instructions, publication <a href="#">20A-IN009</a>	Provides the five basic steps that are needed to install and perform a basic start up of the PowerFlex 70 drive.
Wiring and Grounding Guidelines for Pulse Width Modulated (PWM) AC Drives, publication <a href="#">DRIVES-IN001</a>	Provides the basic information that is needed to properly wire and ground Pulse Width Modulated (PWM) AC drives.
Communication adapter options, publications <a href="#">20COMM-UM.xxx</a>	Provides the information to install the communication option kit based on the 20-COMM-X that is chosen. By searching the specific COMM card, a detailed description of the card features and parameters can be explored. These communication cards are optional and vary depending on configuration.
PowerFlex DriveGuard Safe Torque Off User Manual - Series B. publication <a href="#">PFLEX-UM003</a>	Provides compatibility information for using the DriveGuard® Safe Torque Off option, with PowerFlex 40P or PowerFlex 70 drives and other safety components.
Industry Installation Guidelines for Pulse Width Modulated (PWM) AC Drives, publication <a href="#">DRIVES-AT003</a>	Provides basic information for enclosure systems and environmental/location considerations (to help protect against environmental contaminants), and power and grounding considerations that are needed to properly install AC drives.
Safety Guidelines for the Application, Installation, and Maintenance of Solid State Control, publication <a href="#">SGI-1.1</a>	Provides general guidelines for the application, installation, and maintenance of solid-state control.
Guarding Against Electrostatic Damage, publication <a href="#">8000-4.5.2</a>	Provides practices for guarding against Electrostatic damage (ESD)
Industrial Automation Wiring and Grounding Guidelines, publication <a href="#">1770-4.1</a>	Provides general guidelines for installing a Rockwell Automation industrial system.

You can view or download publications at [rok.auto/literature](http://rok.auto/literature).

You can access declarations of conformity, certificates, and other certification details at: <https://www.rockwellautomation.com/en-us/support/documentation/product-certifications.html>

# Rockwell Automation Support

Use these resources to access support information.

<b>Technical Support Center</b>	Find help with how-to videos, FAQs, chat, user forums, and product notification updates.	<a href="http://rok.auto/support">rok.auto/support</a>
<b>Knowledgebase</b>	Access Knowledgebase articles.	<a href="http://rok.auto/knowledgebase">rok.auto/knowledgebase</a>
<b>Local Technical Support Phone Numbers</b>	Locate the telephone number for your country.	<a href="http://rok.auto/phonesupport">rok.auto/phonesupport</a>
<b>Literature Library</b>	Find installation instructions, manuals, brochures, and technical data publications.	<a href="http://rok.auto/literature">rok.auto/literature</a>
<b>Product Compatibility and Download Center (PCDC)</b>	Download firmware, associated files (such as AOP, EDS, and DTM), and access product release notes.	<a href="http://rok.auto/pcdc">rok.auto/pcdc</a>

## Documentation Feedback

Your comments help us serve your documentation needs better. If you have any suggestions on how to improve our content, complete the form at [rok.auto/docfeedback](http://rok.auto/docfeedback).

## Waste Electrical and Electronic Equipment (WEEE)



At the end of life, this equipment should be collected separately from any unsorted municipal waste.

Allen-Bradley, Compact I/O, Connected Components Workbench, DriveExplorer, DriveGuard, Drive Peripheral Interface (DPI), DriveTools, expanding human possibility, FORCE, PanelView, Rockwell Automation, and Zero-Stacking are trademarks of Rockwell Automation, Inc.

CANopen is a trademark of CAN in Automation

LonWorks is a trademark of Echelon Corporation





DeviceNet, ControlNet, and EtherNet/IP are trademarks of ODVA, Inc.

PROFIBUS is a trademark of PROFIBUS and PROFINET International

Trademarks not belonging to Rockwell Automation are property of their respective companies.

Rockwell Automation maintains current product environmental compliance information on its website at [rok.auto/pec](http://rok.auto/pec).

Rockwell Otomasyon Ticaret A.Ş. Kar Plaza İş Merkezi E Blok Kat:6 34752, İçerenköy, İstanbul, Tel: +90 (216) 5698400 EEE Yönetmeliğine Uygundur

Connect with us.    

[rockwellautomation.com](http://rockwellautomation.com)

expanding **human possibility**

AMERICAS: Rockwell Automation, 1201 South Second Street, Milwaukee, WI 53204-2496 USA, Tel: (1) 414.382.2000, Fax: (1) 414.382.4444

EUROPE/MIDDLE EAST/AFRICA: Rockwell Automation NV, Pegasus Park, De Kleetlaan 12a, 1831 Diegem, Belgium, Tel: (32) 2 663 0600, Fax: (32) 2 663 0640

ASIA PACIFIC: Rockwell Automation, Level 14, Core F, Cyberport 3, 100 Cyberport Road, Hong Kong, Tel: (852) 2887 4788, Fax: (852) 2508 1846