



MODEL FBC-4800SS STAINLESS STEEL FROZEN MEAT CHIPPER

Operating Manual and Parts List

Applicable on Machines Starting with Serial No. 10200



Biro Designed

Biro Built

★ IMPORTANT NOTICE ★

This Manual contains important safety instructions which must be strictly followed when using this equipment.

PTCT
FBC-4800SS
092-2-16-20-B

TABLE OF CONTENTS:

	Page
NOTICE TO OWNERS AND OPERATORS	1
SAFETY TIPS	2
INSTALLATION	3
UNCRATING AND SET UP	3-4
WIRING DIAGRAM	5
OPERATION	6
TO PROCESS PRODUCT	6
TROUBLE SHOOTING MACHINE OPERATION	7
MAINTENANCE	8
CLEANING	9
PARTS DIAGRAMS	10-13
RUNNER/GUILLOTINE BLADE REPLACEMENT & LUBRICATION	14-15
GROVE GEAR REDUCER DIAGRAM & LUBRICATION	16-20
MORSE GEAR REDUCER DIAGRAM & LUBRICATION	21
OLD & NEW STYLE BLADES AND OPERATOR'S NOTES	22
OPTIONAL MEAT FILLER PLATE	23
NOTES	24
OPERATOR'S SIGNATURE PAGE	25
LIMITED WARRANTY	26

NOTICE TO OWNERS AND OPERATORS

BIRO's products are designed to process food products safely and efficiently. Unless the operator is properly trained and supervised, however, there is the possibility of a serious injury. It is the responsibility of the owner to assure that this machine is used properly and safely, strictly following the instructions contained in this Manual and any requirements of local law.

No one should use or service this machine without proper training and supervision. All operators should be thoroughly familiar with the procedures contained in this Manual. Even so BIRO cannot anticipate every circumstance or environment in which its products will be used. You, the owner and operator, must remain alert to the hazards posed by the function of this equipment particularly the MOVING SHUTTLE WITH SHARP CHIPPING BLADES, which can severely injure an inattentive operator amputating fingers and limbs. No one under eighteen (18) years of age should operate this equipment. If you are uncertain about a particular task, ask your supervisor.

This Manual contains a number of safe practices in the SAFETY TIPS section. Additional warnings are placed throughout the Manual. Warnings related to your personal safety are indicated by:



OR



Warnings related to possible damage are indicated by:



BIRO also has provided warning labels on the equipment. If any warning label or Manual becomes misplaced, damaged, or illegible, please contact your nearest Distributor or BIRO directly for a replacement.

Remember, however, this Manual or the warning labels do not replace the need to be alert and to use your common sense when using this equipment.

This Manual applies to SANITARY TIN machines with serial numbers 3100 to 5297, and STAINLESS STEEL machines with serial number 10200 to present.

-NOTE-

**A copy of this manual is included with each MODEL FBC-4800SS
FROZEN MEAT CHIPPER MACHINE.**

**The descriptions and illustrations contained in this manual are not
binding. The manufacturer reserves the right to introduce any
modification without updating the manual.**

SAFETY TIPS



MOVING SHUTTLE WITH SHARP CHIPPING BLADES TO AVOID SERIOUS PERSONAL INJURY

- **NEVER** Touch This Machine without Training and Authorization by Your Supervisor.
- **ALWAYS** Keep Hands Clear of Sharp Chipping Blades and Other Moving Parts.
- **ONLY** Use a Qualified Electrician to Install According to Local building codes: Machine **MUST** Be Properly Grounded.
- **ONLY** Install on Level, Non-skid Surface in a Clean, Well-Lighted Work Area Away from Children and Visitors.
- **DO NOT** Tamper With or Remove Product Chute Cover.
- **NEVER** Operate With the Product Chute Cover in the Open Position.
- **ALWAYS** Close Product Chute Cover Completely Before Operating Machine.
- **ALWAYS** Turn Off, Unplug From Power Source and Perform Lockout/Tagout Procedure to This Machine **BEFORE** Cleaning or Servicing.
- **NEVER** Leave the Machine Unattended While Frozen Meat Chipper is Running.
- **PROMPTLY REPLACE** Any Worn or Illegible Warning Labels.
- **ALWAYS** Read Operation and Service Manual **BEFORE** Operating, Cleaning, or Servicing.
- **USE ONLY BIRO** Parts and Accessories Properly Installed.

INSTALLATION



TO AVOID SERIOUS PERSONAL INJURY, PROPERLY INSTALL EQUIPMENT IN ADEQUATE WORK AREA

- **ALWAYS** Use Qualified Technician and Electrician for Installation.
- **ALWAYS** Connect to **Proper** Voltage & Phase.
- **ALWAYS** Install Equipment in Work Area with Adequate Light and Space Away From Children and Visitors.
- **ONLY** Operate on a Solid, Level, Non-Skid Surface.
- **NEVER** Bypass, Alter or Modify This Equipment in Any Way From Its Original Condition.
- **NEVER** Operate With Product Chute Cover in Open Position.
- **NEVER** Operate Without all Warning Labels Attached and Owner/Operator Manual Available to the Operator.

UNCRATING AND SET UP

1. Read this Manual thoroughly before installation and operation. **Do not** proceed with installation and operation if you have any questions or do not understand anything in this Manual. Contact your local Distributor, or **BIRO FIRST**.
2. Carefully remove cardboard crate wraparound. Remove meat lug dolly and set aside.
3. Remove 3/8 bolt and nut holding machine to wood crate bottom.
4. Remove Meat Lug (Item No. 51199-MHD) from top of machine.
5. Install casters (3 ea. Item No. 51165 less brake and 1 ea. Item 51164 with brake) on the stainless steel Meat Lug Dolly (Item No. 51582) with supplied fasteners. Set Meat Lug and Dolly aside.
6. With assistance of mechanical devices, lift machine and block up. Remove machine legs from side of machine. Replace legs to same mounting holes in vertical position, tightening the acorn nuts on the carriage bolts.
7. Remove stainless steel Chute Cover (Item No. 51597) from top of machine. Turn over and mount to stand offs at top of chute opening. Tighten Chute Cover Hinge Pins (Item No. 51563). Do not over tighten. Chute should be centered and still have free movement to open and close. Magnet should be centered over safety switch. Tighten jam nuts on hinge pins.
8. Install Chute Cover Support (Item No. 51404) to Chute Cover. Be sure bushing is used to allow free movement of chute support. Be sure chute support is in lock bracket welded to side of chute.
9. Place machine on a level, solid, non-skid surface in a well-lighted work area away from children and visitors.
10. Install floor stops over the front leg pads (opposite motor end). It is recommended that floor stops be anchored to the floor with two 3/8-16 x 1 1/2" expansion anchors per floor stop.

11. After checking and making sure that the power supply is correct, plug in your machine.
12. Machine must be properly grounded. Use qualified electrician to install according to local building codes.
13. With rear motor cover removed and chute cover in the closed position, push the green “start” button located on the side of the rear cover. Be sure that the motor and transmission are rotating in the proper direction. Should be COUNTERCLOCKWISE when viewing the transmission output shaft and machine crank arm, as indicated by the arrow on crank arm. Should machine be operating backwards, push red “stop” button. Disconnect machine from incoming power source and interchange two lead wires.
14. When machine is operating in proper direction, replace rear motor cover. Machine is now ready for trained operators to process product.

MOTOR WIRING AND ELECTRICAL REQUIREMENTS

- (1) Interchange of current is made in motor outlet box. Leads are properly marked. Changing instructions are on the motor plate or motor outlet box.
- (2) All chippers are wired 220 volts unless otherwise specified. Be sure motor specifications (voltage, cycle, phase) match power supply line. Be sure line voltage is up to specification.
- (3) Electrical connections to be in accordance with safety codes and National Electrical Code.
- (4) Rated voltage of the unit shall be identical with full supply voltage.
- (5) Voltage drop on the supply line shall not exceed 10% of full supply voltage.
- (6) The feederline conductor size in the raceway from the branch circuit to the unit must be correct to assure adequate voltage under heavy starting and short overload conditions.
- (7) The feederline conductor shall only be used for the supply of one unit of the relevant horsepower. For connections of more than one unit on the same feederline, a local electrician will have to be consulted to determine the proper conductor size.
- (8) The size of the electrical wiring required from the power source to the frozen block chipper is a **MINIMUM OF No. 10 WIRE** if the distance from the machine to electrical box is 25 feet or less. Over 25 feet a **MINIMUM OF No. 8 WIRE** is to be used.
- (9) The BIRO Manufacturing Company is not responsible for permanent wiring, connection or installation.



NOTE TO OWNER AND ELECTRICIAN: IF THIS MACHINE IS NOT CORD AND PLUG CONNECTED TO THE ELECTRICAL SUPPLY SOURCE, THEN IT SHOULD BE EQUIPPED WITH, OR CONNECTED TO, A LOCKABLE, MANUALLY-OPERATED DISCONNECT SWITCH (OSHA 1010.147).

MOTOR SPECIFICATIONS			FURNAS HEATER ELEMENTS	
VOLTS	HERTZ	AMPS	CODE NO.	BIRO ITEM NO.
208	60	16.2	E62	50704
230	60	14.0	E61	52744
460	60	7.0	E51	50703
575	60	6.0	E50	50668
190	50	16.7	E62	50704
220	50	14.4	E60	50667
380	50	8.7	E54	50705
415	50	8.0	E53	50670

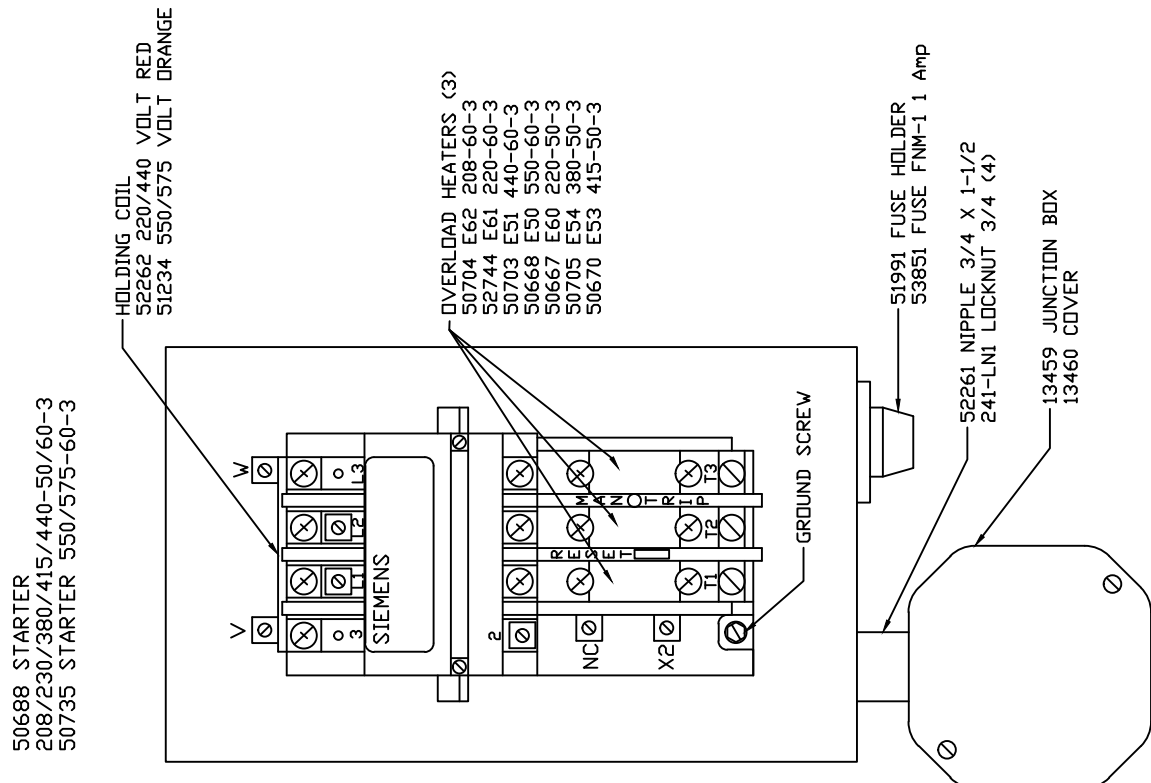

WIRING DIAGRAM

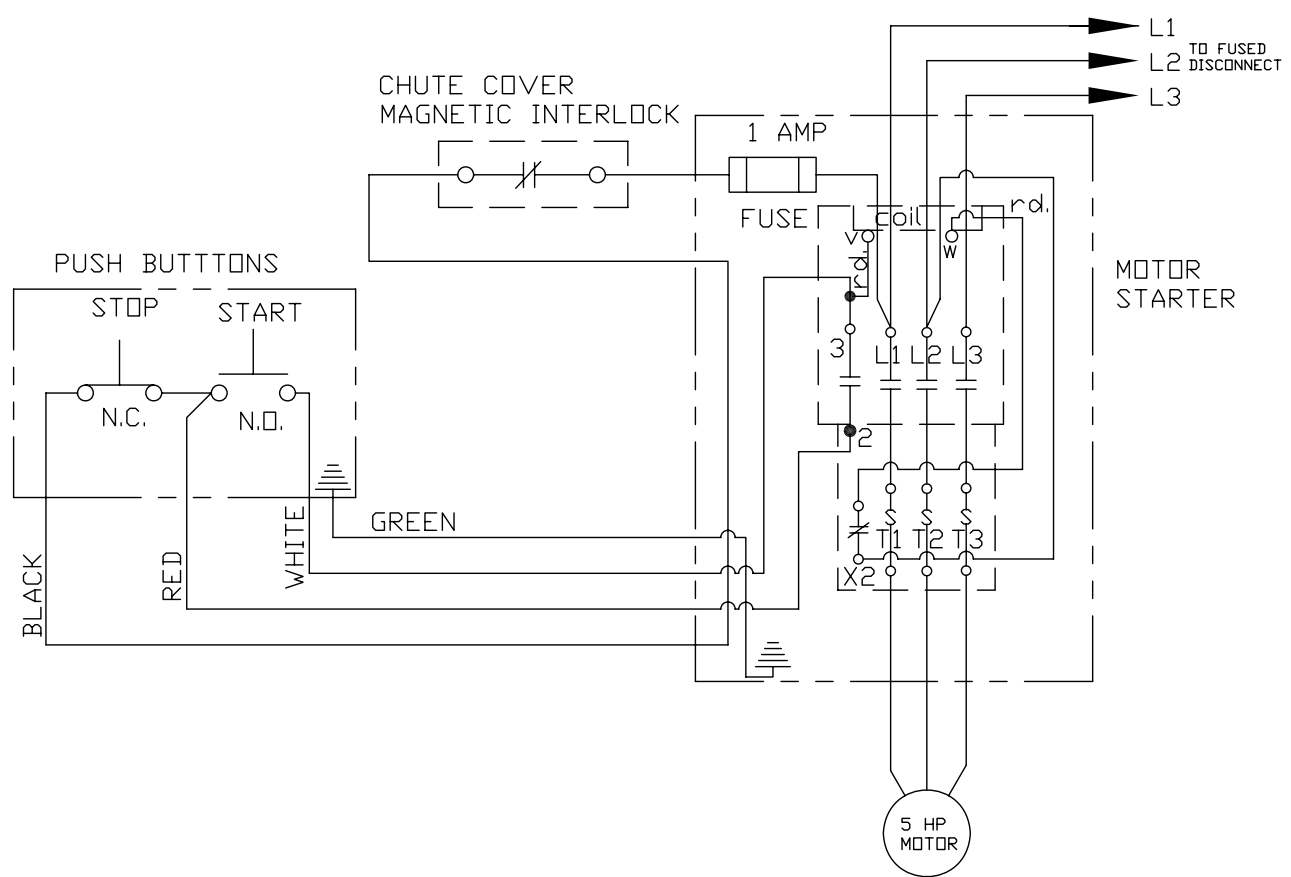

OPERATION



MOVING SHUTTLE WITH SHARP CHIPPING BLADES TO AVOID SERIOUS PERSONAL INJURY

- **ONLY** Properly Trained Personnel Should Use This Equipment.
- **ALWAYS** Keep Hands Clear of Sharp Chipping Blades and Other Moving Parts.
- **NEVER** Operate With Product Chute Cover in the Open Position.
- **DO NOT** Tamper With or Remove Product Chute Cover.
- **ALWAYS** Close Product Chute Cover Completely Before Operating Machine.
- **DO NOT** Tamper With, Bypass, Alter, or Modify This Equipment in Any Way From Its Original Condition.
- **ALWAYS** Turn Off, Unplug from Power Source and Perform Lockout/Tagout Procedure to This Machine Before Cleaning or Servicing, or When Not in Use.
- **NEVER** Leave the Machine Unattended While Frozen Meat Chipper is Running.
- **NEVER** Operate Without All Warnings Attached.

A. TO PROCESS PRODUCT

1. Place Meat Lug under machine to catch chipped product.
2. Prepare for processing a 60 pound tempered meat block. For optimum chipping the recommended block temperature is 15 to 25 degrees F. With a maximum block size of 8" x 16 ½" x 19 ½". This will yield finished product chips approx. 3 ½" x 3 ½" x ¼". For narrower meat blocks there is available an optional Chute Filler Plate (Item No. 51526).
3. Lift the Chute Cover slightly to release the Chute Support. Close the chute cover completely. The magnet attached to the chute must contact the safety switch. The machine will not operate with the Chute Cover in the open position.
4. Push the green "START" button. When the machine is finished chipping, which should be approx. 60 seconds, push the red "STOP" button. Unplug machine from power source and perform lockout/tagout procedures.
5. Remove meat lug from under machine. Product is now ready for grinding or mixing/grinding.

B. TROUBLE SHOOTING MACHINE OPERATION

1. Machine is not chipping properly. Check the following items:
 - A. Product block may be frozen too hard (temperature should be 15-25 degrees F).
 - B. Product block may be too soft.
 - C. Either the Guillotine Knife (Item No. 51380) or the Runner Blades (Item No. 51379) may be dull or broken.
 - D. Chute Spring (Item No. 51416) may be missing, broken, or have lost its temper.
 - E. Product block may be too narrow, install optional Chute Filler (Item No. 51526).
 - F. The machine may be running in the wrong direction. Check rotation arrow on the Crank Arm (Item No. 51387) for proper direction. COUNTERCLOCKWISE- looking at transmission output shaft.
 - G. Slide bearings in shuttle may be worn (Item No's. 51502 & 51503, two each).
 - H. Guillotine Knife (Item No. 51380) may have been installed backwards.
 - I. Guillotine Knife and Runner Blades may have been resharpened beyond their life span.
 - J. Slide Rods (Item No. 51382) may be dry. Lubricate with good grade food machine oil.

2. Machine is not operating properly. Check the following mechanical items:
 - A. Crank Arm Pin sheared (Item No. 51054). Replace.
 - B. Transmission Bronze Drive Gear damaged or stripped (Item No. 51074-7). Replace.
 - C. Transmission Shaft Key sheared (Item No. 51074-16). Replace.
 - D. Motor Shaft Key sheared (Item No. 51074-28). Replace.

MAINTENANCE



MOVING SHUTTLE WITH SHARP CHIPPING BLADES TO AVOID SERIOUS PERSONAL INJURY

- **ALWAYS** Turn Off, Unplug from Power Source and Perform Lockout/Tagout Procedures to This Machine **BEFORE** Servicing.
- **NEVER** Touch This Machine Without Training and Authorization by Your Supervisor.
- **NEVER** Place Hands Into Machine Input or Output Openings.
- **NEVER** Bypass, Alter, or Modify This Equipment in Any Way From Its Original Condition.
- **PROMPTLY REPLACE** Any Worn or Illegible Labels.
- **USE ONLY GENUINE BIRO** Parts and Accessories Properly Installed.

LUBRICATION

1. SLIDE RODS: Lubricate daily or after each cleaning with a good grade food oil.
2. CRANK PIN: Soak Felt Wick (Item No. 51285) once a year with 90 weight oil.
3. TRANSMISSION: Change after first month of operation, then every one year after.
For room temperatures above 20 deg. F. use SAE90 multi-purpose gear oil.
For room temperatures below 20 deg. F. use SAE80 multi-purpose gear oil.
4. MOTOR: Grease Zerk fitting on top and bottom of motor once a year.
5. GEAR BOX: Grease Zerk fitting on top of gear box once a year.

SHUTTLE ASSEMBLY

1. GUILLOTINE KNIFE: Check for wear and dulling. Resharpen or replace as necessary.
2. RUNNER BLADES: Check for wear and dulling. Resharpen or replace as necessary. Replace any broken blades.
3. SLIDE BEARINGS: Check for excessive free play. Replace as necessary.

CLEANING

MOVING SHUTTLE WITH SHARP CHIPPING BLADES TO AVOID SERIOUS PERSONAL INJURY



- **ALWAYS** Turn Off, Unplug from Power Source and Perform Lockout/Tagout Procedures to This Machine **BEFORE** Servicing.
- **ONLY** Use Recommended Cleaning Equipment, Materials and Procedures.
- **NEVER** Spray Water or Other Liquid Substances Directly at Motor, Power Switch or Any Other Electrical Components.
- **ALWAYS** Thoroughly Clean Equipment at Least Daily.

CLEANING THE BIRO FROZEN BLOCK CHIPPER:

1. Turn “OFF”, unplug machine from power source, and perform lockout/tagout procedures.
2. Lift Chute Cover until notch in Chute Cover Support is in line with bracket on the side of the chute. Disengage Chute Cover Support from bracket by pulling outward. Lift Chute Cover to fully open position and allow to rest on top of the Drive Cover.
3. Loosen Hand Wheel (Item No. 51048) securing the Upper Frame Assembly (Item No. 51558). Move the Hand Wheel and Catch Rod down to the unlock position. The Upper Frame Assembly is hinged to facilitate cleaning. Lift to open Upper Frame Assembly. Assembly must be opened fully and resting against welded Chute Cover hinge.



DO NOT SPRAY DIRECTLY AT ELECTRICAL COMPONENTS

4. Machine is now ready to be cleaned using warm soapy water and rinsed with clean water. Machine may be cleaned by power spray washing, taking care not to spray directly at any electrical controls.
5. The shuttle may be removed for cleaning. This is accomplished by removing the hex head screws holding the shuttle to the bearing bars.
6. After machine has been cleaned and allowed to air dry, the Slide Rods (Item No. 51382) should be coated with a good food grade light oil or grease.

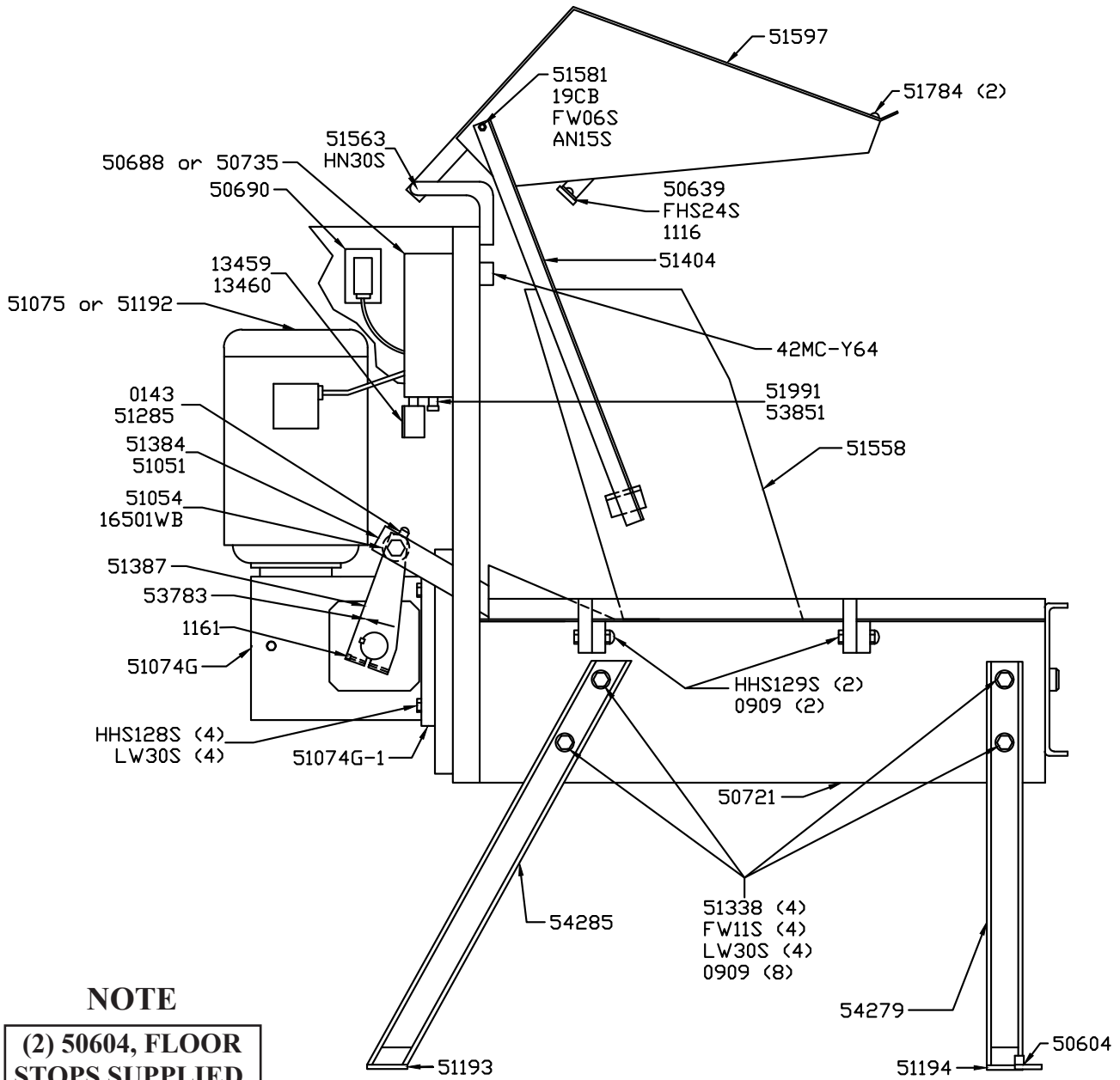

NOTE

**(2) 50604, FLOOR
STOPS SUPPLIED.
RECOMMENDED
FOR USE WITH
(4) 3/8-16 x 1 1/2", &
(4) EXPANSION
ANCHORS, NOT
SUPPLIED.**

PARTS LIST

For: SANITARY TIN MACHINES starting with Serial No. 3100 to Serial No. 5297

&

For: STAINLESS STEEL MACHINES starting with Serial No. 10200

IMPORTANT: ALWAYS ADVISE SERIAL NUMBER WHEN ORDERING PARTS

ITEM NO.	DESCRIPTION
HHS129S	Hex Head Screw, 1/2-13 x 2, SS; Attach Upper Frame to Lower Frame
0909	Acorn Nut, 1/2-13, SS; Attach Upper Frame to Lower Frame
50721	Lower Frame Assembly, Stainless Steel (NSS)
54279	Front Leg, Stainless Steel
51338	Leg Carriage Bolt, 1/2-13 x 1, SS
FW11S	Flat Washer, 1/2", SS
LW30S	Lock Washer, 1/2", SS
0909	Acorn Nut, 1/2-13, SS
50604	Floor Stop
51194	Front Leg Pad
51193	Rear Leg Pad
54285	Right Rear Leg, Stainless Steel
51387	Crank
1161	Allen Screw, 1/2-13 x 2"
53783	Rotation Decal
51074G	Transmission (see page 16-20) Grove gear reducer
51074	Transmission (see page 21) Morse reducer (Obsolete)
72251	Transmission Oil, 2 qts. (90 weight) Morse reducer (Obsolete)
HHS128S	Hex Head Screw, 1/2-13 x 1 3/4", SS
LW30S	Lock Washer, 1/2", SS
51054	Crank Pin
16501WB	Thrust Washer, Brass
51384	Pitman Arm Assembly with Bushings, Wick & Pipe Plug, SS
51051	Pitman Arm bushings, Bronze
0143	Pipe Plug, 1/2"
51285	Felt Wick
50688	Magnetic Starter, 208/230/380/415/460-50/60-3
50735	Magnetic Starter, 575-60-3
See Page 4 for Item No.	Overload Heater Coils
51075	Motor, 5HP, 208/230/380/415/460-50/60-3
51192	Motor, 5HP, 575-60-3
51074-28	Motor Shaft key, 3/16 x 2"
51991	Fuse Holder
53851	Fuse, 1 Amp, FNM-1
50639	Magnet for Safety Switch
FHS24S	Flat Head Screw, 10-32 x 5/8", SS
1116	Acorn Nut, 10-32, SS
42MC-Y64	Magnetic Safety Switch, to 240V
51404	Chute Cover Support
51581	Chute Cover Support Bushing
19CB	Carriage Bolt, 1/4-20 x 3/4", SS
FW06S	Flat Washer, 1/4", SS
AN15S	Acorn Nut, 1/4-20", SS
51558	Upper Frame Assembly, Stainless Steel
13459	Junction Box
13460	Junction Box Cover
51563	Chute Cover Hinge Pin, SS
HN30S	Hex Nut 3/8 -16, SS
51074G-1	Sub Plate (Grove gear reducer)
51597	Chute Cover
51784	Rubber Bumper
50690	Push Button Junction Box

SLIDE ASSEMBLY

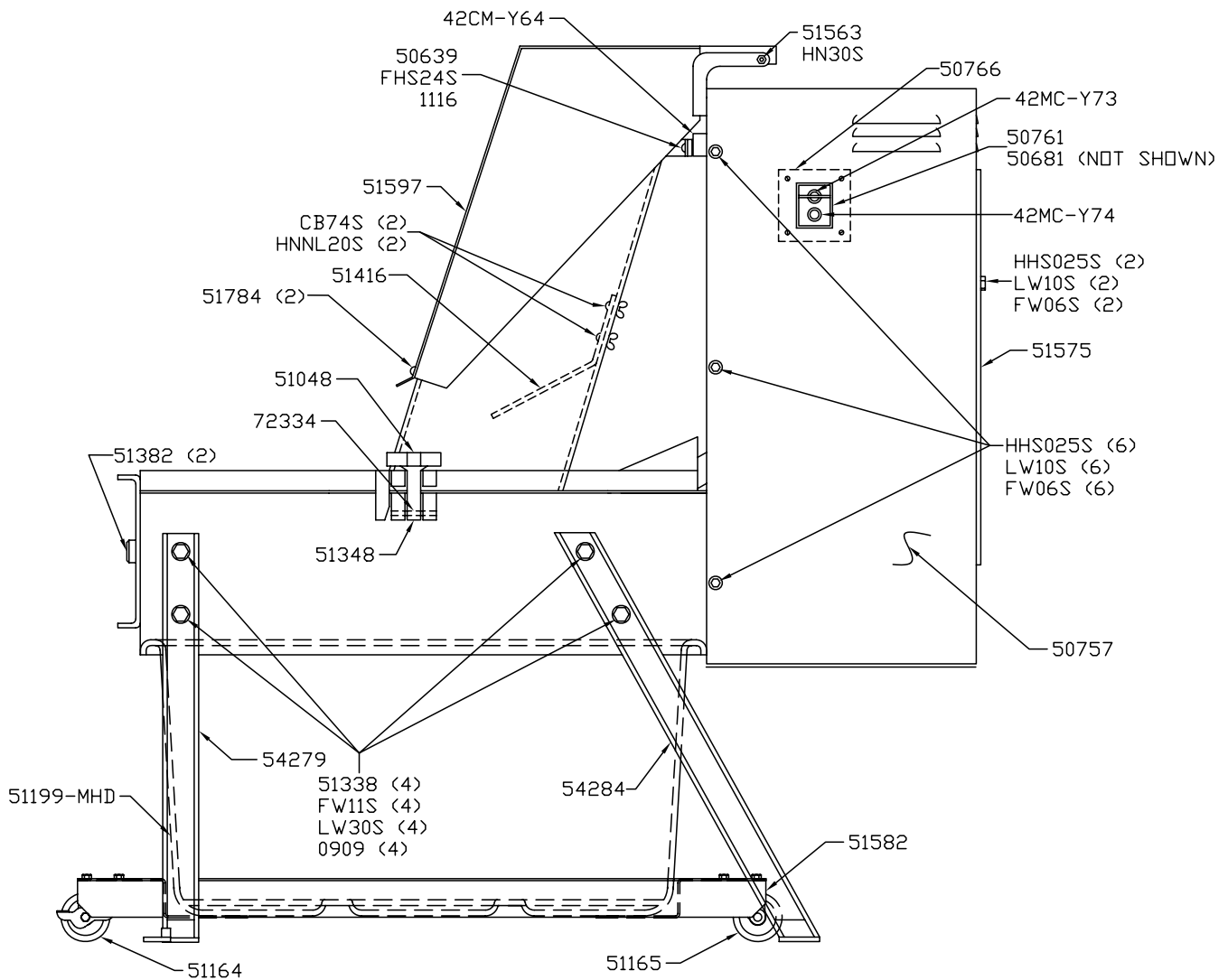
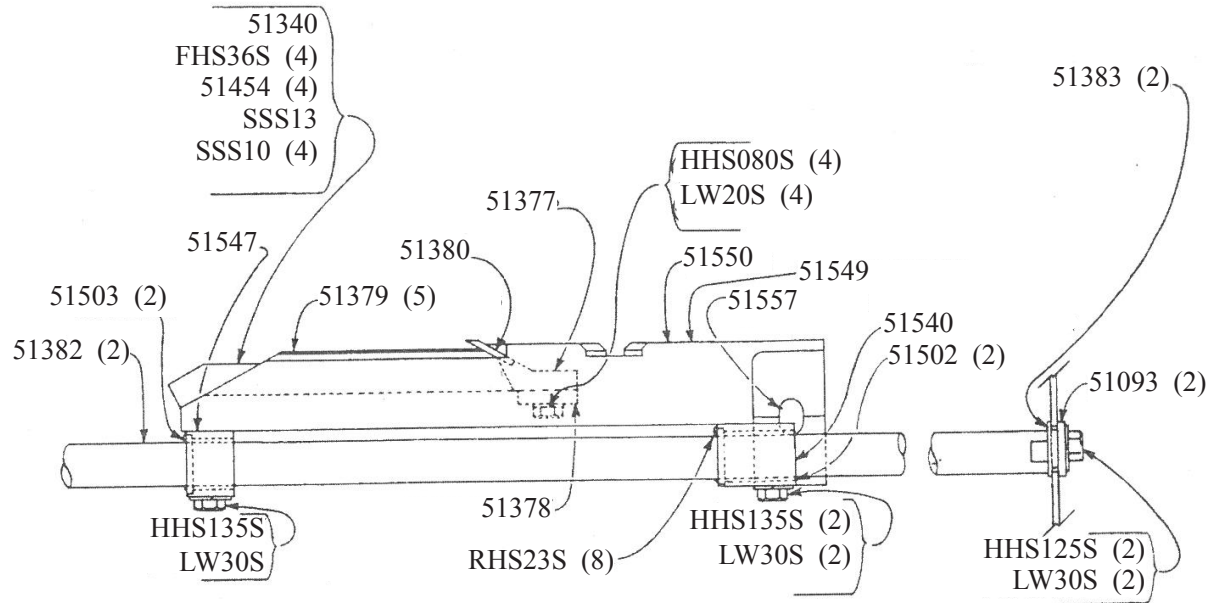

PARTS LIST

IMPORTANT: ALWAYS ADVISE SERIAL NUMBER WHEN ORDERING PARTS

ITEM NO.	DESCRIPTION
51382	Slide Rod, SS
51547	Front Bearing Bar Assembly with Bearings
51503	Front Slide Bearings
HHS135S	Hex Bolt, 1/2-13 x 2 1/2", SS
LW30S	Lock Washer, 1/2", SS
51340	Runner Blade Retainer
FHS36S	Flat Head Screw, 1/4-20 x 1", SS
51454	Runner Blade Adjusting Set Screw
SSS13	Runner Blade Adjusting Set Screw, 1/4-20 x 3/8
SSS10	Locking Set Screw, 1/4-20 x 1/4"
51378	Runner Support
HHS080S	Hex Head Screw, 3/8 -16 x 1 1/2", SS
LW20S	Lock Washer, 3/8, SS
51379	Runner Blade, Tapered Ends
51380	Guillotine Knife
51377	Knife Clamp, Rear
51550	Bare Slide, SS
51549	Slide Assembly Complete
RHS23S	Round Head Screw, 1/4-20 x 3/8", SS, Bearing Retainer
51540	Rear Bearing Bar w/ Slide Bushings
51502	Rear Slide Bearings
51557	Pitman Arm Pin
51383	Slide Rod Bushing, SS
51093	Slide Rod Washer
HHS125S	Hex Head Screw, 1/2-13 x 1", SS
54284	Left Rear Leg, SS
42MC-Y64	Magnetic Safety Switch, to 240V
50639	Magnet for Safety Switch
FHS24S	Flat Head Screw, 10-32 x 5/8", SS
1116	Acorn Nut, 10-32, SS
72334	Groove Pin for Catch Rod
51348	Catch Rod, SS
51048	Hand Wheel
51416	Chute Spring
CB74S	Carriage Bolt, 5/16-18 x 3/4", SS
HNNL20S	Hex Nut, Nylok, 5/16-18, SS
51784	Rubber Bumper for Chute Cover
51597	Chute Cover Assembly, SS
51575	Drive Cover Door
51563	Chute Cover Hinge Pins, SS
HN30S	Hex Nut 3/8 -16, SS
50757	Drive Cover, SS
HHS025S	Hex Head Screw, 1/4-20 x 1/2", SS
LW10S	Lock Washer, 1/4", SS
FW06S	Flat Washer, 1/4", SS
50761	Push Button Plate w/ Hood
50681	Gasket
42MC-Y73	Green Start Button
42MC-Y74	Red Stop Button
50766	Switch Hole Filler Plate
51338	Leg Carriage Bolt, 1/2-13 x 1", SS
FW11S	Flat Washer, 1/2", SS
0909	Acorn Nut, 1/2-13, SS
54279	Front Leg, SS
50777	Operating Manual & Parts List (Not Shown)
51165	Caster Less Brake
51164	Caster With Brake
51582	Lug Dolly Assembly w/ Casters, SS
51335	Lug Dolly Less Casters, SS (Not Shown)
51199-MHD	Meat Lug

RUNNER BLADE AND GUILLOTINE BLADE REPLACEMENT PROCEDURE

1. Remove the slide assembly hex head mounting bolts (3 ea.)
2. Remove Item No. 51549 slide assembly from the machine.
3. Place on workbench.
4. Remove the runner support hex head bolts (4 ea.)
5. Remove Item No. 51378 runner support and Item No. 51377 knife clamp.
6. Clean the runner blade mounting grooves in the knife clamp.
7. Remove Item No. SSS10 locking set screws (4 ea.) and back out Item No. 51454 and No. SSS13S runner blade adjusting screws (5 ea.)
8. Do not remove Item No. 51340 runner blade retainer.
9. Remove Item No. 51379 runner blades (5 ea.) and Item No. 51380 guillotine knife.
10. Clean the grooves.
11. Slide new Item No. 51379 runner blades into the slide frame under the Item No. 51340 runner blade retainer.
12. Lay new Item No. 51380 guillotine knife on the slide frame.
13. Push Item No. 51379 runner blades into the knife clamp.
14. Assemble Item No. 51377 knife clamp and Item No. 51378 runner support and bolt to the slide frame using the 4 ea. $\frac{3}{8}$ -16 x 1 $\frac{1}{2}$ " hex bolts and lock washers.
15. Be sure Item No. 51379 runner blades are sitting square and flush against Item No. 51380 guillotine knife and Item No. 51377 knife clamp.
16. Tighten the mounting bolts.
17. Re-tighten the 5 ea. Item No. 51454 and No. SSS13S runner blade adjusting set screws until they are snug. Do not over-tighten. Insert and tighten the 4 ea. $\frac{1}{4}$ -20 x $\frac{1}{4}$ locking set screws in all adjusting set screw holes except the middle one.
18. This assembly will prevent putting the runner blades in a bind.
19. Remount the slide assembly into the machine.

SHUTTLE ASSEMBLY

1. GUILLOTINE KNIFE: Check for wear and dulling. Resharpen or replace as necessary.
2. RUNNER BLADES: Check for wear and dulling. Resharpen or replace as necessary. Replace any broken blades.
3. SLIDE BEARINGS: Check for excessive free play. Replace as necessary.

LUBRICATION

1. SLIDE RODS: Lubricate daily or after each cleaning with a good grade food oil.
2. CRANK PIN: Soak Felt Wick (Item No. 51285) once a year with 90 weight oil.
3. MOTOR: Grease Zerk fitting on top and bottom of motor once a year.
4. GEAR BOX: Grease Zerk fitting on top of gear box once a year.

No. 51549 Slide Assembly Complete With Blades and Without Bearing Bars

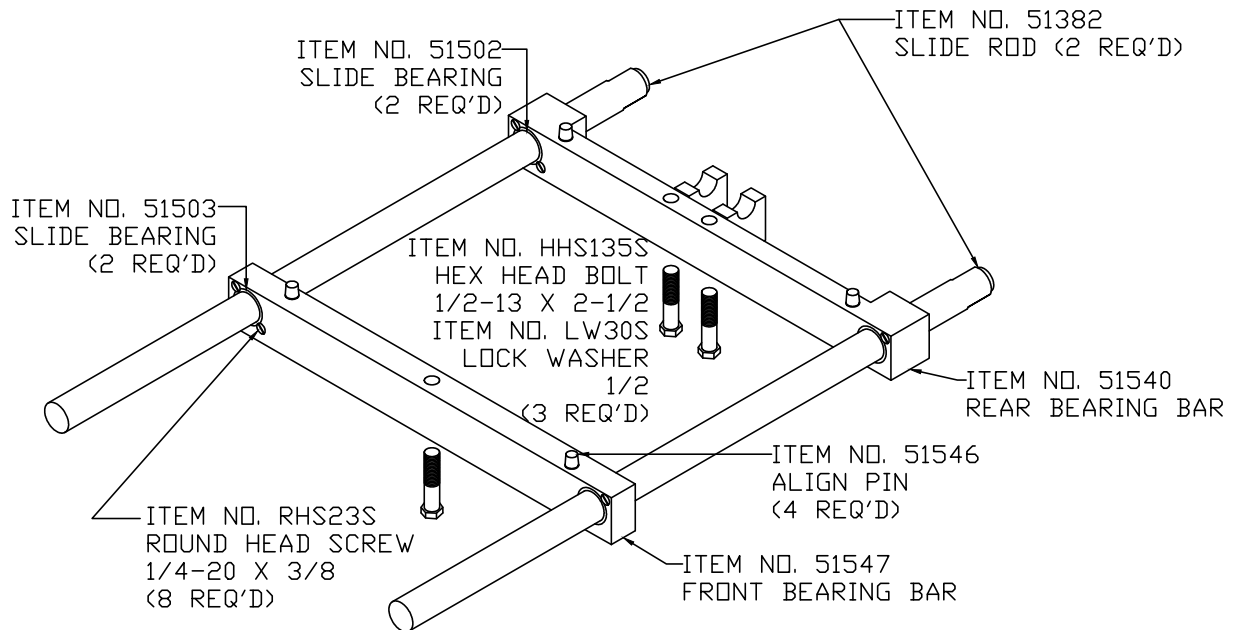
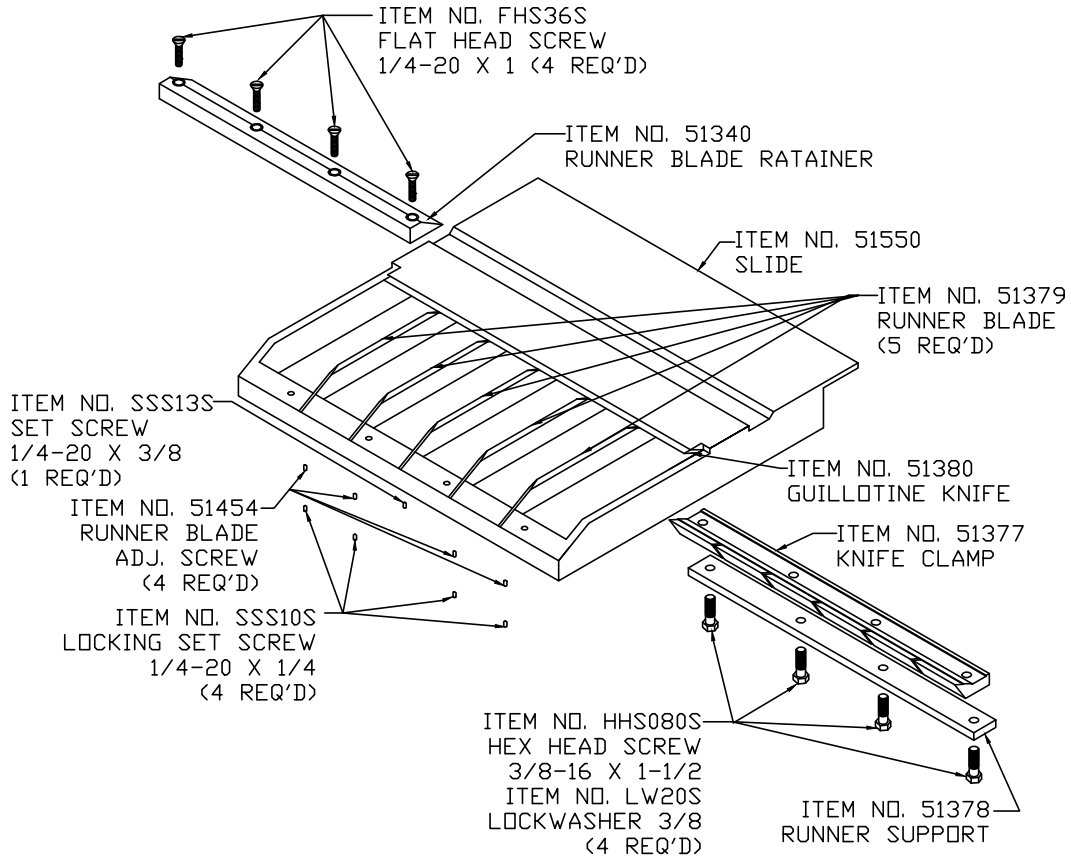

INSTALLATION INSTRUCTIONS

GROVE GEAR REDUCER REPLACING MORSE GEAR REDUCER

- **ALWAYS** Turn Off, Unplug From Power Source and Perform Lockout/Tagout Procedures to the Machine **BEFORE** Any Service is Performed.

REMOVAL

- Remove Item No. 51575 Drive Cover Door.
- Remove four bolts holding the Item No. 50690 Pushbutton box to the Item No. 50757 Drive cover and let box hang free.
- Remove the Item No. 50757 Drive Cover.
- Open the motor junction box and disconnect the electrical leads. Remove the switch wires and conduit from the motor.
- Remove the motor from the OEM gear reducer(Morse), taking care to locate the motor key.
- Remove the Item No. 51054 Crank Pin and Item No. 16501WB Thrust Washer from the Item No. 51384 Pitman Arm and rest at the bottom of the base access slot.
- Loosen the Item No. 1161 Allen Screw in the Item No. 51387 Crank. Remove the Crank from the gear reducer output shaft. This may require a puller. Keep track of the Crank Key.
- Remove the four bolts holding the Gear Reducer to the machine frame and remove the Gear Reducer.

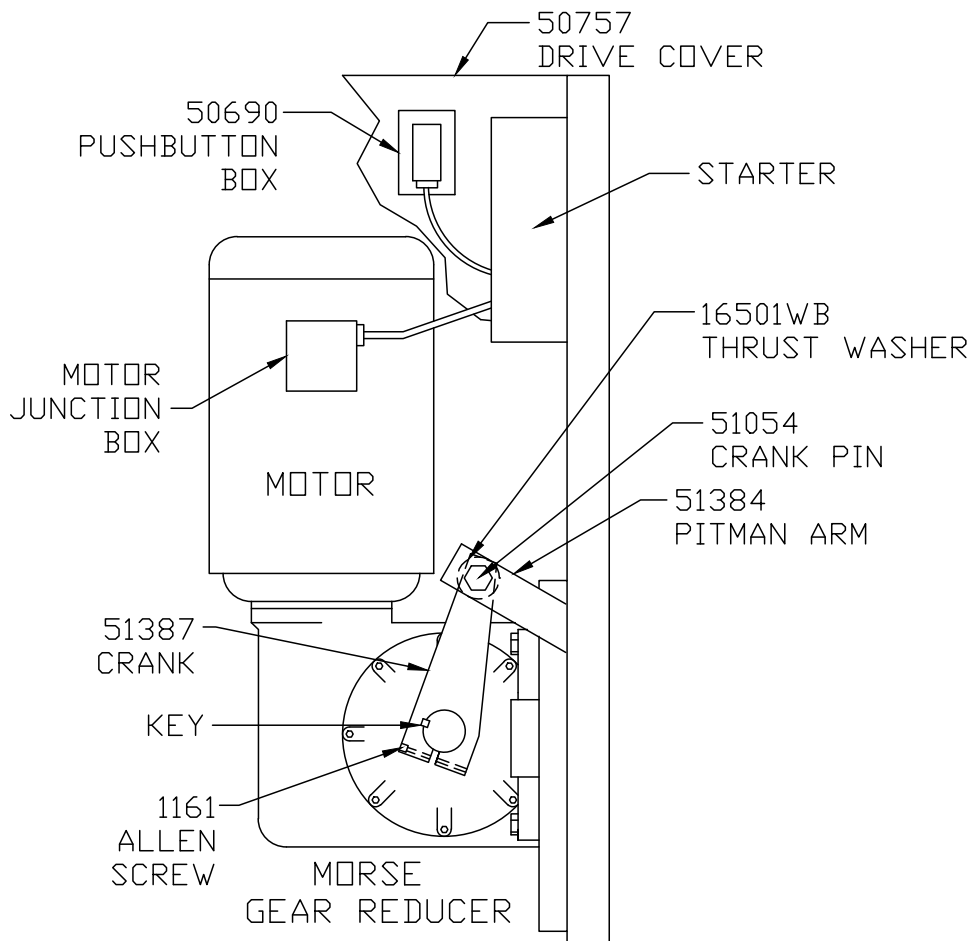

INSTALLATION

- A. Put the four 1/2-13 x 1 3/4 bolts and lock washers in the mounting plate first. Attach the mounting plate to the Gear Reducer (Grove) using the four 7/16-14 x 1 3/4 bolts and lock washers.
- B. Mount the Gear Reducer and Mounting Plate combination to the machine frame and tighten the four 1/2-13 bolts. Remove the factory plug and replace with the plastic vented plug in the filler plug hole shown in the drawing.

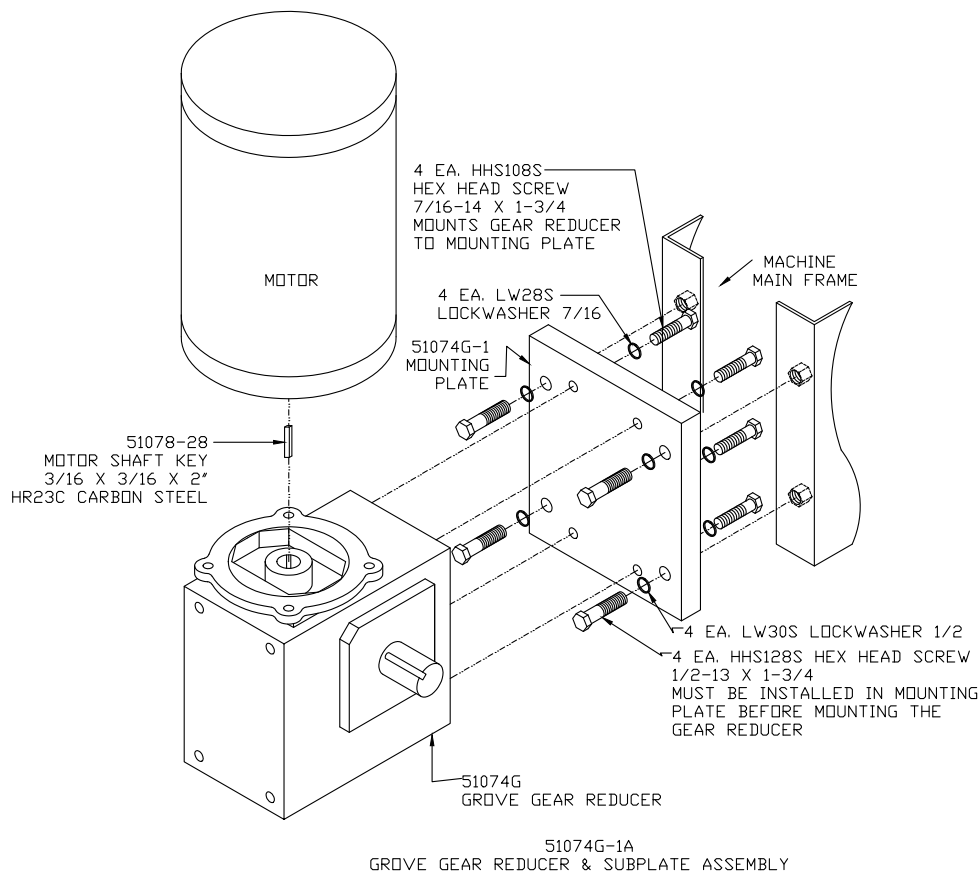

- C. Reinstall the Motor into the Gear Reducer. Be sure the Motor Key is properly in place, Tighten the Motor Bolts.
- D. Reinstall the Motor wires and conduit. Reattach the wires. Taking care that the Motor wiring diagram is followed for proper voltage.
- E. Being aware of location of all other personnel while the Motor is being tested for proper rotation, plug the machine into power source. Push the start button and note rotation of Gear Reducer output shaft. It should rotate counterclockwise when viewing from shaft side. If not, interchange two lead wires. Unplug the machine from power source for final installation.
- F. Reinstall the Item No. 51387 Crank and Crank Key. Tighten the Item No. 1161 Allen Screw.
- G. Reinstall the Item No. 51384 Pitman Arm using the Item No. 51054 Crank Pin and Item No. 16501WB Thrust Washer. If the Crank and Pitman Arm do not line up, move the Pitman Arm by sliding the Slide Assembly forward or backward until alignment is achieved.
- H. Reinstall the Item No. 50757 Drive Cover.
- I. Reinstall the Item No. 50690 Push Button Box.
- J. Reinstall the Item No. 51575 Drive Cover Door.
- K. Plug machine into power source and check for proper operation.

LUBRICATION FOR GROVE GEAR REDUCER

1. Factory Filling

The speed reducers are oil filled at the factory to the proper level for the standard mounting position. The oil level should be checked and adjusted (if necessary) prior to operation, using the oil level plug provided and while the unit is oriented in its operating position.

2. Oil Changing



**WHEN CHANGING OIL FOR ANY REASON,
DO NOT MIX DIFFERENT OILS IN THE REDUCER.
OILS SHOULD BE COMPATIBLE WITH
VITON[®] SEAL MATERIAL.**

Therefore, when changing to a different oil, it is recommended that the housing be completely drained and thoroughly flushed with a light flushing oil prior to refilling with the appropriate lubricant. The oil level should be rechecked after a short period of operation and adjusted, if necessary.



**OIL SHOULD BE CHANGED MORE OFTEN IF THE
REDUCER IS USED IN A SEVERE ENVIRONMENT
(i.e., DUSTY, HUMID).**

A. Initial Oil Change

The oil in a new speed reducer should be changed at the end of 250 hours of operation (30 days for 8 hour per day service, 15 days for 16 hour service, 10 days for 24 hour service.)

B. Subsequent Oil Changes

Under normal conditions, after the initial oil change, the oil should be changed after every 2500 hours of operation, or every six months, whichever occurs first. Under severe conditions (rapid temperature changes, moist, dirty or corrosive environment) it may be necessary to change oil at intervals of one to three months. Periodic examination of oil samples taken from the unit will help establish the appropriate interval.

C. Synthetic Oils

Synthetic lubricants can be advantageous over mineral oils in that they generally are more stable, have a longer life, and operate over a wider temperature range. These oils are appropriate for any application but are especially useful when units are subjected to low start-up temperatures or high operating temperatures. Use of synthetics can cause problems if they are not compatible with the seals or the conventional lubricants they replace. For continuous duty at normal ambient temperatures (-10°F to 105°F) we recommend the use of **Mobile SCH 634** which is compatible with the standard compounded oil shipped in our product and the Viton[®] seal material used through size 252.

3. Overfilling or Underfilling

If a speed reducer is overfilled with oil, the energy used in churning the excessive oil can result in overheating. If this occurs, shut down the drive, remove the oil level plug and allow oil to drain until oil ceases to drain from the level hole, reinstall the oil level plug and restart the drive. If the speed reducer is under filled, the resultant friction can cause overheating and possible damage. If this occurs, fill the speed reducer to the oil level plug hole and check the gearing for excessive wear. NOTE: Oil capacity is 1¾ pints.

4. Oil Seals

Although the speed reducer uses high quality oil seals and precision ground shafts to provide a superior seal contact surface, it is possible that circumstances beyond the speed reducer's control can cause oil seal leakage (damage during shipment or installation, etc.) When replacing a shaft oil seal, using the following suggestions will help to insure leak-free operation and long seal life.

A. When installing a new seal, cover the keyway and any other surface discontinuity with smooth tape to protect the seal lip from being damaged.

B. A sealant should be used between the O.D. of the seal and the I.D. of the bore into which the seal is installed. The seal bore should also be free of any burrs, nicks, or scratches.

C. Be sure that the seal is not cocked in the seal bore. The outer face of the seal should be flush with the surface into which it is mounted.

51074G GEAR REDUCER LUBRICATION AND MAINTENANCE

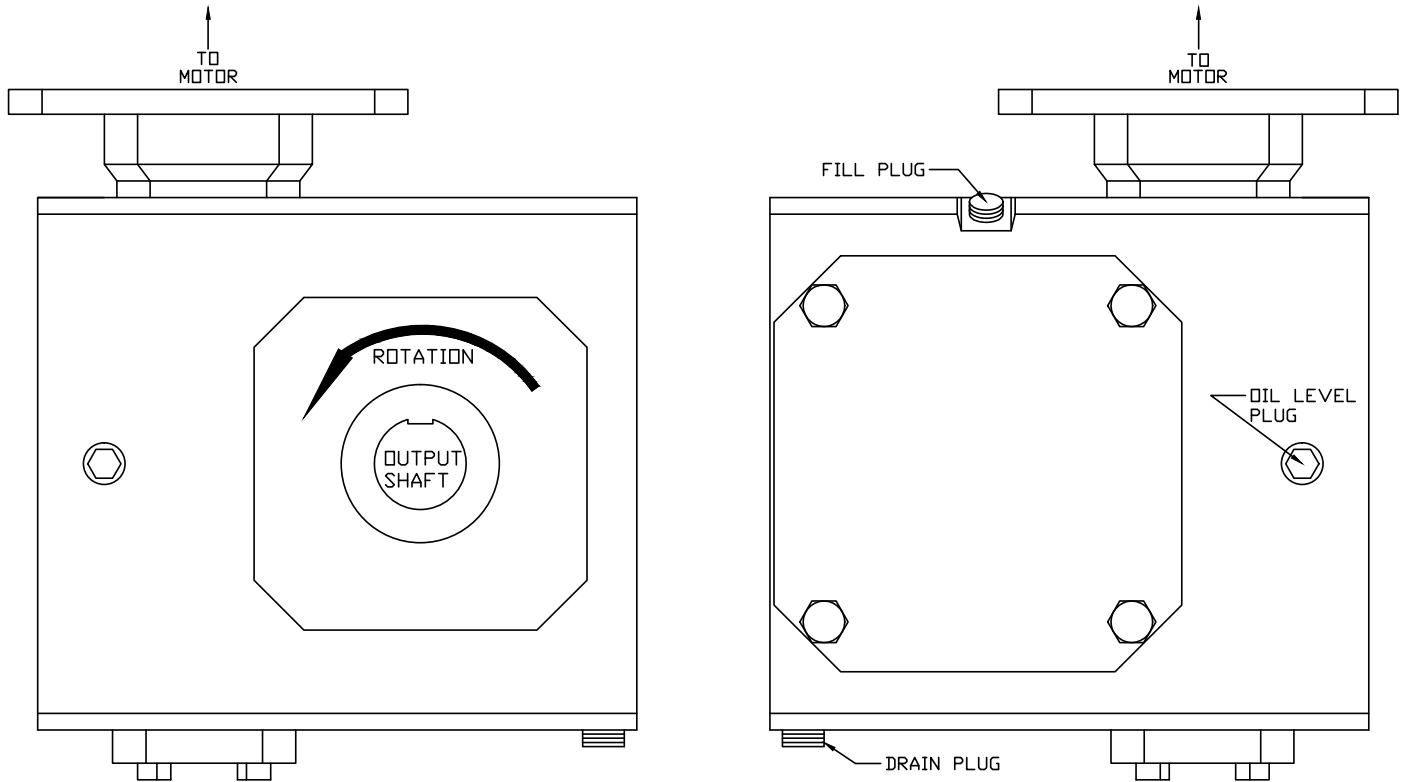

LUBRICANTS FOR 51074G GEAR REDUCER WORM GEAR REDUCERS

The precision-made gears and bearings in Grove Gear Speed Reducers require high-grade lubricants of the proper viscosity to maintain trouble-free performance. For best results, use lubricants on the following chart for worm gear reducers.

Manufacturer	30° to 100°F Ambient Temperature AGMA Compounded No. 7	50° to 125°F Ambient Temperature AGMA Compounded No. 8
Amoco Oil Co.	Worm Gear Oil	Cylinder Oil #680
Chevron USA, Inc.	Cylinder Oil #460X	Cylinder Oil #680X
Exxon Co. USA	Cyclesstic TK-460	Cyclesstic TK-680
Gulf Oil Co.	Senate 460	Senate 680D
Mobile Oil Corp.	600 W Super Cylinder	Extra Hecla Super
Shell Oil Co.	Valvata Oil J460	Valvata Oil J680
Sun Oil Co.	Gear Oil 7C	Gear Oil 8C
Texaco	Honor Cylinder Oil	650T Cylinder Oil
Union Oil Co. of CA	Steaval A	Worm Gear Lube 140

Standard factory-installed lubricant is Mobile Oil Corp. 600 W Super Cylinder Oil (AGMA7).

Some gear lubricants contain E.P. additives that can be corrosive to gear bronze. Avoid lubricants that are compounded with sulfur and/or chlorine.

No. 51074G GROVE GEAR REDUCER PARTS DIAGRAM

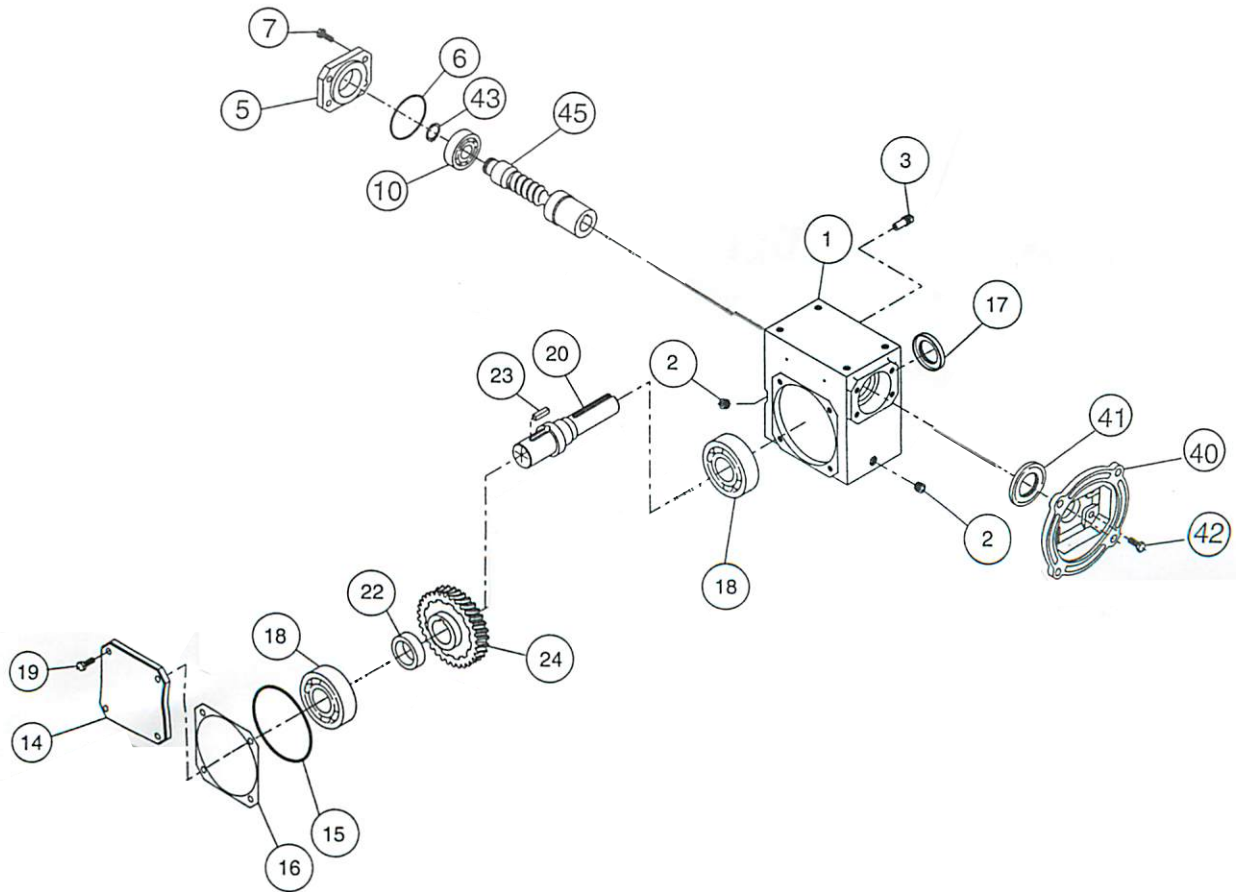

Item No.	Description	Item No.	Description
51074G-1	Gear housing	51074G-18	Output bearing (cup & cone)
51074G-2	Pipe plug	51074G-19	Hex head cap screw
51074G-3	Vent plug	51074G-20	Single output shaft 1 $\frac{3}{8}$ dia.
51074G-5	Input cover	51074G-22	Gear spacer
51074G-6	O-ring	51074G-23	Gear key
51074G-7	Hex head cap screw	51074G-24	Output gear
51074G-10	Input bearing	51074G-40	Quill motor flange
51074G-14	Output cover	51074G-41	Input oil seal
51074G-15	O-ring	51074G-42	Hex head cap screw
51074G-16	Output cover gasket (as requested)	51074G-43	Retaining ring- shaft
51074G-17	Output oil seal	51074G-45	Quill input shaft

MORSE GEAR REDUCER

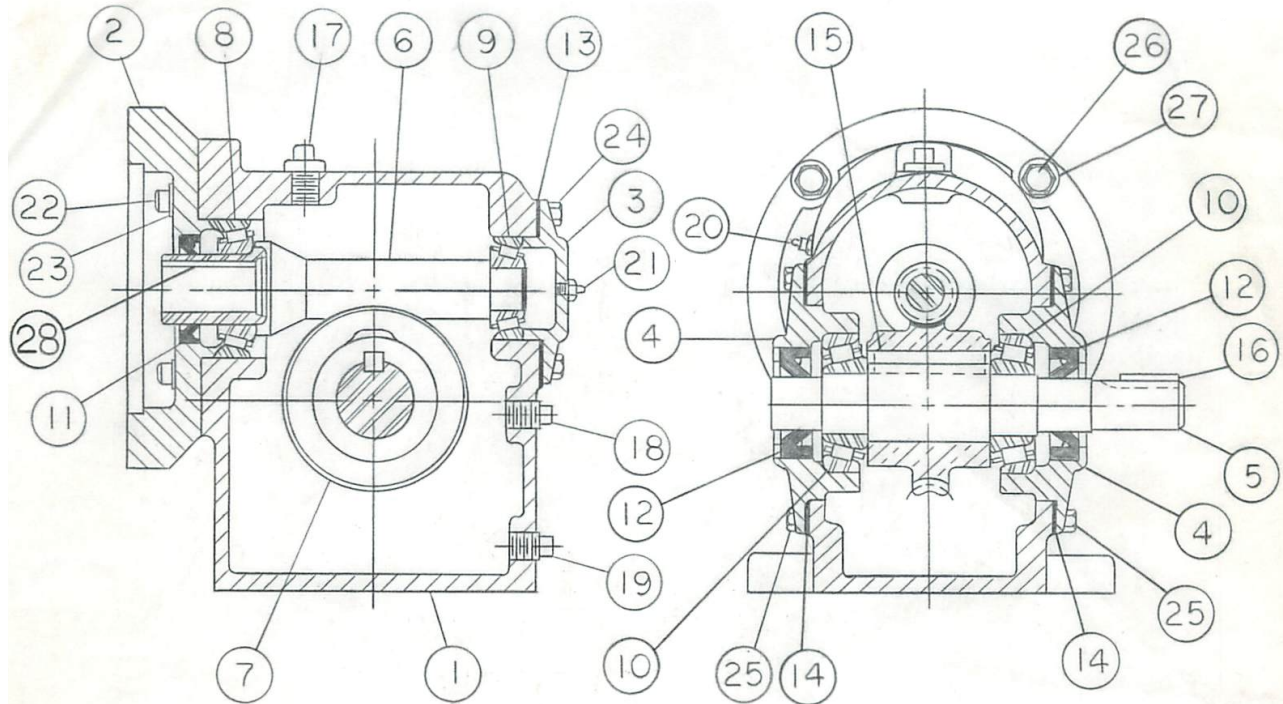

CUT AWAY OF BIRO FROZEN BLOCK CHIPPER TRANSMISSION PART No. 51074

Item No.	Description	Item No.	Description
51074-1	Housing	51074-10	Bearing output
51074-5	Output shaft	51074-11	Oil seal input
51074-6	Worm $\frac{7}{8}$ Bore	51074-12	Oil seal output
51074-7	Gear	51074-15	Key gear
51074-8	Bearing input	51074-16	Key output
51074-9	Bearing input	51074-28	Motor shaft key (3/16 x 1 $\frac{3}{8}$)

LUBRICATION

TRANSMISSION: Change after first month of operation, then every year after.
 For room temperatures above 20 deg. F, use SAE90 multi-purpose gear oil.
 For room temperatures below 20 deg. F, use SAE80 multi-purpose gear oil.

OLD STYLE AND NEW STYLE BLADES & KNIVES

Due to replacement of old style slide assemblies with the new style slide assemblies on the early Model FBC-4800SS BIRO Frozen Block Chippers, it has become necessary that we ask you to order your runner blades and guillotine knives by Style/Item Number.

Please see sketches below and order accordingly on all future orders.

STYLE "1"  #51057 INSERT

#51287 RUNNER BLADE
BEFORE S/N 1600

STYLE "2"

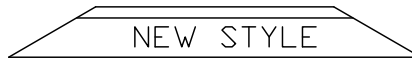

#51379 RUNNER BLADE
AFTER S/N 1600

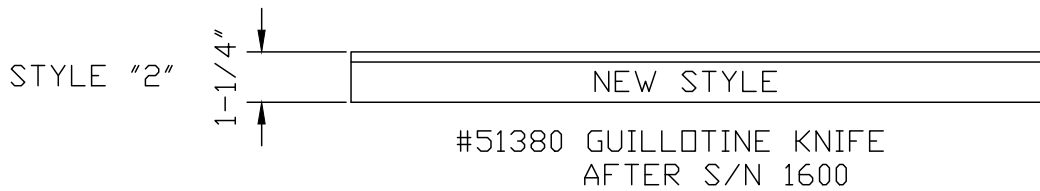
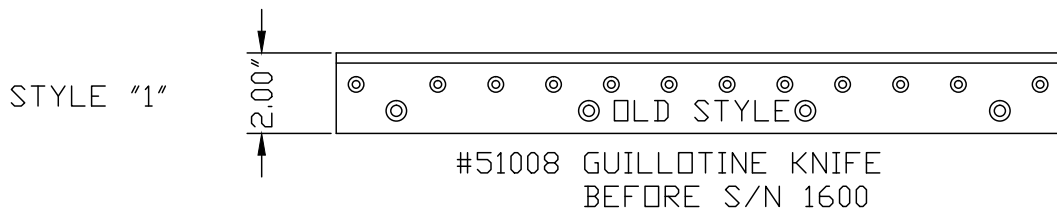

-NOTES-

OPTIONAL MEAT FILLER PLATE NO. 51526

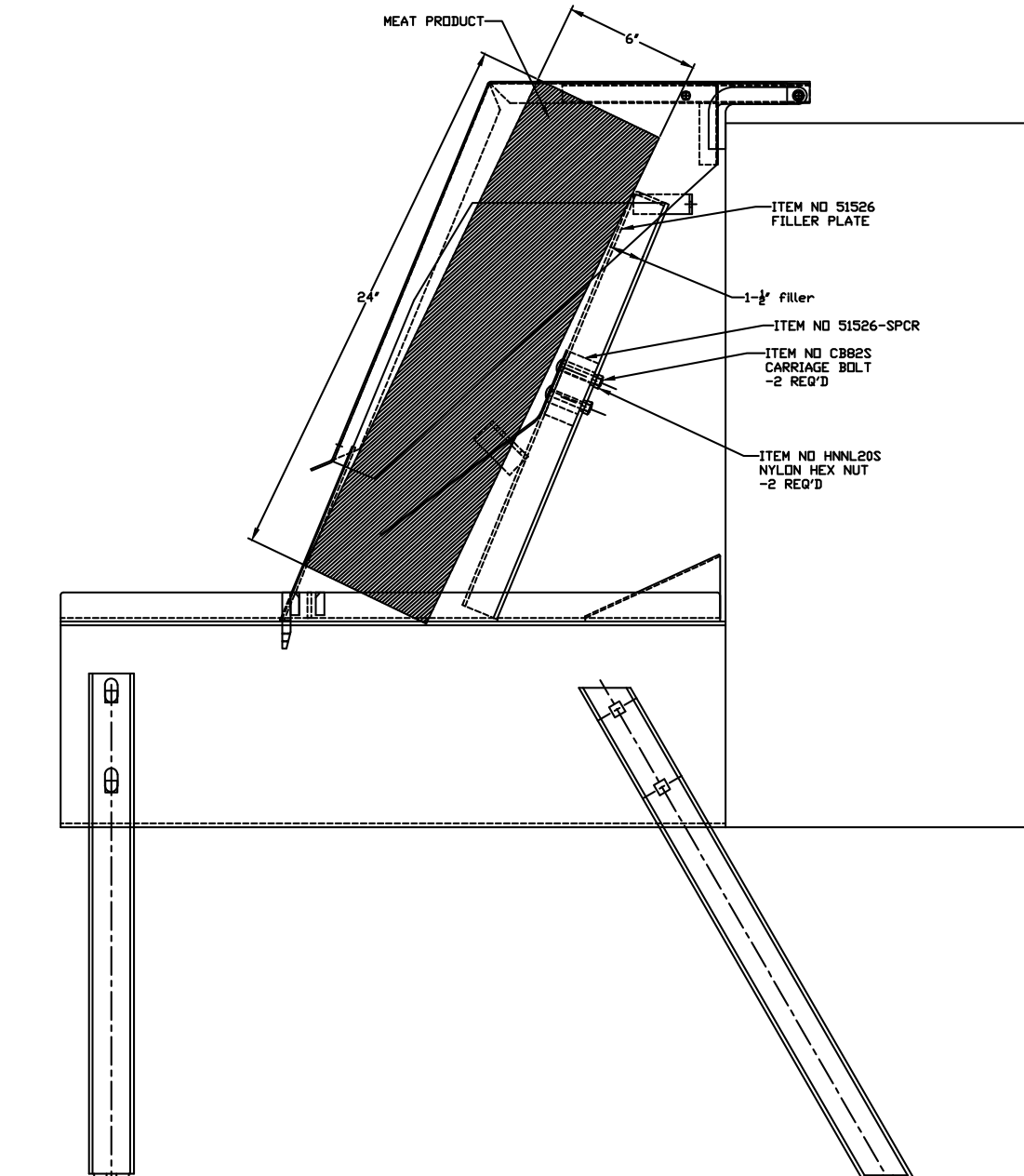

-NOTES-

LIMITED WARRANTY

WARRANTY: The BIRO Manufacturing Company warrants that the BIRO Model FBC-4800SS will be free from defects in material and workmanship under normal use and with recommended service. BIRO will replace defective parts, which are covered by this limited warranty, provided that the defective parts are authorized for return, shipping charges prepaid, to a designated factory for inspection and/or testing.

DURATION OF WARRANTY: The warranty period for all parts covered by this limited warranty is one (1) year from date of inspection/demonstration as advised on the returned Warranty registration card, or eighteen (18) months from original factory shipping date, whichever date occurs first, except as noted below.

PARTS NOT COVERED BY WARRANTY: The following are **not** covered by this limited warranty: wearable parts such as the meat lug, guillotine knife, runner blades, chute spring, and nylon bearings. This limited warranty does not apply to machines sold as used, rebuilt, modified, or altered from the original construction in which the machine was shipped from the factory. Water contaminated electrical systems are not covered under this limited warranty. BIRO is not responsible for electrical connection of equipment, adjustments to switch components or any other electrical requirements, which must be performed only by a certified electrician. BIRO is not responsible for service charges or labor required to replace any part covered by this limited warranty or for any damages resulting from misuse, abuse, lack of proper or recommended service.

EXCLUSION OF WARRANTIES AND LIMITATION OF REMEDIES: BIRO gives no warranties other than those expressly stated in this limited warranty. THE IMPLIED WARRANTY OF MERCHANTABILITY, THE IMPLIED WARRANTY OF FITNESS FOR PROCESSING OF FOOD PRODUCTS, AND ALL OTHER IMPLIED WARRANTIES ARE SPECIFICALLY EXCLUDED. BIRO IS NOT LIABLE FOR CONSEQUENTIAL OR INCIDENTAL DAMAGES, EXPENSES OR LOSSES. THE REMEDIES PROVIDED IN THIS BIRO LIMITED WARRANTY ARE PURCHASER'S SOLE AND EXCLUSIVE REMEDIES AGAINST BIRO.

REGISTRATION CARDS: You must sign, date and complete the warranty registration card supplied with each machine. The warranty card must be returned to The Biro Manufacturing Company for proper registration. If no warranty card is returned to BIRO, the warranty period will begin from the date the machine was originally shipped from the factory.

HOW TO GET SERVICE:

1. Contact the agency from whom you purchased the machine; or
2. Consult the yellow pages of the phone directory for the nearest authorized dealer; or
3. Contact Biro Mfg. Company for the nearest authorized service entity in your area.

BIRO MANUFACTURING COMPANY

1114 Main St.

Marblehead, OH 43440 U.S.A.

Telephone: 419-798-4451 Fax: 419-798-9106

E-mail: service@birosaw.com; www.birosaw.com