



Start-Up, Operation, and Maintenance Instructions

CONTENTS

	Page
SAFETY CONSIDERATIONS	2
INTRODUCTION	4
ABBREVIATIONS AND EXPLANATIONS	4
CHILLER FAMILIARIZATION (FIG. 1-5)	4
Chiller Information Nameplate	4
System Components	4
Cooler	4
Condenser	4
Motor-Compressor	4
Control Panel	4
Power Panel (19XR2-E)	5
Power Panel (19XR6/7)	5
Economizer (if available)	5
Free-Standing/Factory-Mounted Starter or VFD ...	5
Storage Vessel (Optional)	5
REFRIGERATION CYCLE	11
MOTOR AND OIL COOLING CYCLE	12
VFD Cooling Cycle	12
LUBRICATION CYCLE	13
Summary	13
Details	13
Bearings	13
Oil Reclaim System	13
STARTING EQUIPMENT	16
Unit-Mounted VFDs	16
Unit-Mounted Starters	16
Solid-State Starter	16
Wye-Delta Starter	16
Free-Standing Starters/VFDs	17
CONTROLS	17
Definitions	17
General	17
PIC 6 System Components	17
START-UP/SHUTDOWN/ RECYCLE SEQUENCE	19
Local Start/Stop Control	19
Lubrication Control	20
Shutdown	20
BEFORE INITIAL START-UP	20
Job Data Required	20
Equipment Required	20
Remove Shipping Packaging	20
Open Oil Circuit Valves	20
Tighten All Gasketed Joints	21
Check Chiller Tightness	21
Refrigerant Tracer	23
Leak Test Chiller	23
Standing Vacuum Test	23
Chiller Dehydration	25
Inspect Water Piping	25
Check Relief Valves	25
Check the Optional Pumpout Compressor Water Piping	25
Identify and Check Starter/VFD	25
Mechanical Starter	26
Benshaw RediStart MX3 Solid-State Starter	26
VFD Starter	26
Verify Condition of Installation	26
Inspect Wiring	26
Carrier Comfort Network® (CCN) and Local Equipment Network (LEN) Interface	27
Check Starter	27
Oil Charge	28
Power Up Controls and Check Oil Heater	28
Software Configuration	28
Input the Design Set Points	28
Input the Local Occupied Schedule	28
Input Service Configurations	29
Field Set Up and Verification	31
Perform a Controls Test (Quick Test/ Quick Calibration)	34
Check Optional Pumpout System Controls and Compressor	34
Charge Refrigerant into Chiller	34
INITIAL START-UP	37
Preparation	37
Check Motor Rotation	37
Check Oil Pressure and Compressor Stop	37
To Prevent Accidental Start-Up	37
Check Chiller Operating Condition	37
Instruct the Customer Operator	37
OPERATING INSTRUCTIONS	38
Operator Duties	38
Prepare the Chiller for Start-Up	38
To Start the Chiller	38
Check the Running System	38
To Stop the Chiller	38
After Limited Shutdown	38
Preparation for Extended Shutdown	38
After Extended Shutdown	39
Cold Weather Operation	39

Manual Guide Vane Operation	39
Refrigeration Log	39
PUMPOUT AND REFRIGERANT	
TRANSFER PROCEDURES	39
Preparation	39
Operating the Optional Pumpout Unit (Fig. 37) ...	41
GENERAL MAINTENANCE	44
Refrigerant Properties	44
Adding Refrigerant	44
Adjusting the Refrigerant Charge	44
Refrigerant Leak Testing	44
Leak Rate	44
Test After Service, Repair, or Major Leak	44
Repair the Leak, Retest, and Apply	
Standing Vacuum Test	44
Checking Guide Vanes	44
Trim Refrigerant Charge	44
WEEKLY MAINTENANCE	47
Check the Lubrication System	47
SCHEDULED MAINTENANCE	47
Service Ontime	47
Inspect the Control Panel	47
Changing Oil Filter	47
Oil Specification	47
Oil Changes	47
Refrigerant Filter	47
VFD Refrigerant Strainer (if equipped)	48
Oil Reclaim Filter	48
Inspect Refrigerant Float System	48
Inspect Relief Valves and Piping	49
Compressor Bearing and Gear Maintenance	49
Inspect the Heat Exchanger Tubes and	
Flow Devices	49
Water Leaks	49
Water Treatment	49
Inspect the Starting Equipment or VFD	50
Recalibrate Pressure Transducers	50
Optional Pumpout System Maintenance	50
Ordering Replacement Chiller Parts	50
TROUBLESHOOTING GUIDE	51
Overview	51
Checking Display Messages	51
Checking Temperature Sensors	51
Checking Pressure Transducers	55
High Altitude Locations	55
Quick Test	55
Pumpdown/Lockout	55
Physical Data	55
APPENDIX A — PIC 6 SCREEN AND TABLE	
STRUCTURE	109
APPENDIX B — CCM COMMUNICATION WIRING	
FOR MULTIPLE CHILLERS (TYPICAL)	111
APPENDIX C — MAINTENANCE SUMMARY	
AND LOG SHEETS	112
INDEX	115
INITIAL START-UP CHECKLIST	
FOR 19XR SEMI-HERMETIC TWO-STAGE	
CENTRIFUGAL LIQUID CHILLER	CL-1

SAFETY CONSIDERATIONS

Centrifugal liquid chillers are designed to provide safe and reliable service when operated within design specifications. When operating this equipment, use good judgment and safety precautions to avoid damage to equipment and property or injury to personnel.

Be sure you understand and follow the procedures and safety precautions contained in the chiller instructions as well as those listed in this guide.

⚠ DANGER

Failure to follow these procedures will result in severe personal injury or death.

DO NOT VENT refrigerant relief valves within a building. Outlet from rupture disc or relief valve must be vented outdoors in accordance with the latest edition of ANSI/ASHRAE 15 (American National Standards Institute/American Society of Heating, Refrigerating, and Air-Conditioning Engineers). The accumulation of refrigerant in an enclosed space can displace oxygen and cause asphyxiation.

PROVIDE adequate ventilation in accordance with ANSI/ASHRAE 15, especially for enclosed and low overhead spaces. Inhalation of high concentrations of vapor is harmful and may cause heart irregularities, unconsciousness, or death. Misuse can be fatal. Vapor is heavier than air and reduces the amount of oxygen available for breathing. Product causes eye and skin irritation. Decomposition products are hazardous.

DO NOT USE OXYGEN to purge lines or to pressurize a chiller for any purpose. Oxygen gas reacts violently with oil, grease, and other common substances.

NEVER EXCEED specified test pressures; **VERIFY** the allowable test pressure by checking the instruction literature and the design pressures on the equipment nameplate.

DO NOT USE air for leak testing. Use only refrigerant or dry nitrogen.

DO NOT VALVE OFF any safety device.

BE SURE that all pressure relief devices are properly installed and functioning before operating any chiller.

RISK OF INJURY OR DEATH by electrocution. High voltage is present on motor leads even though the motor is not running when a solid-state or wye-delta mechanical starter is used. Open the power supply disconnect before touching motor leads or terminals.

⚠ WARNING

Failure to follow these procedures may result in personal injury or death.

DO NOT USE TORCH to remove any component. System contains oil and refrigerant under pressure.

To remove a component, wear protective gloves and goggles and proceed as follows:

1. Shut off electrical power to unit.
2. Recover refrigerant to relieve all pressure from system using both high-pressure and low pressure ports.
3. Traces of vapor should be displaced with nitrogen and the work area should be well ventilated. Refrigerant in contact with an open flame produces toxic gases.
4. Cut component connection tubing with tubing cutter and remove component from unit. Use a pan to catch any oil that may come out of the lines and as a gage for how much oil to add to the system.
5. Carefully unsweat remaining tubing stubs when necessary. Oil can ignite when exposed to torch flame.

DO NOT USE eyebolts or eyebolt holes to rig chiller sections or the entire assembly.

DO NOT work on high-voltage equipment unless you are a qualified electrician.

DO NOT WORK ON electrical components, including control panels, switches, starters, or oil heater until you are sure ALL POWER IS OFF and no residual voltage can leak from capacitors or solid-state components.

LOCK OPEN AND TAG electrical circuits during servicing. IF WORK IS INTERRUPTED, confirm that all circuits are de-energized before resuming work.

AVOID SPILLING liquid refrigerant on skin or getting it into the eyes. USE SAFETY GOGGLES. Wash any spills from the skin with soap and water. If liquid refrigerant enters the eyes, IMMEDIATELY FLUSH EYES with water and consult a physician.

NEVER APPLY an open flame or live steam to a refrigerant cylinder. Dangerous overpressure can result. When it is necessary to heat refrigerant, use only warm (110°F [43°C]) water.

DO NOT REUSE disposable (nonreturnable) cylinders or attempt to refill them. It is DANGEROUS AND ILLEGAL. When cylinder is emptied, evacuate remaining gas pressure, loosen the collar, and unscrew and discard the valve stem. DO NOT INCINERATE.

CHECK THE REFRIGERANT TYPE before adding refrigerant to the chiller. The introduction of the wrong refrigerant can cause damage or malfunction to this chiller.

Operation of this equipment with refrigerants other than those cited herein should comply with ANSI/ASHRAE 15 (latest edition). Contact Carrier for further information on use of this chiller with other refrigerants.

DO NOT ATTEMPT TO REMOVE fittings, covers, etc., while chiller is under pressure or while chiller is running. Be sure pressure is at 0 psig (0 kPa) before breaking any refrigerant connection.

CAREFULLY INSPECT all relief valves, rupture discs, and other relief devices AT LEAST ONCE A YEAR. If chiller operates in a corrosive atmosphere, inspect the devices at more frequent intervals.

DO NOT ATTEMPT TO REPAIR OR RECONDITION any relief device when corrosion or build-up of foreign material (rust, dirt, scale, etc.) is found within the valve body or mechanism. Replace the device.

DO NOT install relief devices in series or backwards.

⚠ WARNING

USE CARE when working near or in line with a compressed spring. Sudden release of the spring can cause it and objects in its path to act as projectiles.

⚠ CAUTION

Failure to follow these procedures may result in personal injury or damage to equipment.

DO NOT STEP on refrigerant lines. Broken lines can whip about and release refrigerant, causing personal injury.

DO NOT climb over a chiller. Use platform, catwalk, or staging. Follow safe practices when using ladders.

USE MECHANICAL EQUIPMENT (crane, hoist, etc.) to lift or move inspection covers or other heavy components. Even if components are light, use mechanical equipment when there is a risk of slipping or losing your balance.

BE AWARE that certain automatic start arrangements CAN ENGAGE THE STARTER, TOWER FAN, OR PUMPS. Open the disconnect *ahead of* the starter, tower fans, or pumps.

⚠ CAUTION

USE only repair or replacement parts that meet the code requirements of the original equipment.

DO NOT VENT OR DRAIN waterboxes containing industrial brines, liquid, gases, or semisolids without the permission of your process control group.

DO NOT LOOSEN waterbox cover bolts until the waterbox has been completely drained.

DO NOT LOOSEN a packing gland nut before checking that the nut has a positive thread engagement.

PERIODICALLY INSPECT all valves, fittings, and piping for corrosion, rust, leaks, or damage.

PROVIDE A DRAIN connection in the vent line near each pressure relief device to prevent a build-up of condensate or rain water.

DO NOT re-use compressor oil or any oil that has been exposed to the atmosphere. Dispose of oil per local codes and regulations.

DO NOT leave refrigerant system open to air any longer than the actual time required to service the equipment. Seal circuits being serviced and charge with dry nitrogen to prevent oil contamination when timely repairs cannot be completed.

INTRODUCTION

Prior to initial start-up of the 19XR unit, those involved in the start-up, operation, and maintenance should be thoroughly familiar with these instructions and other necessary job data. Procedures in this manual are arranged in the sequence required for proper chiller start-up and operation. This book also outlines the control system for those involved in the start-up, operation, and maintenance of the unit before performing start-up procedures. It is intended to be used in combination with the 19XR Controls Operation and Troubleshooting manual that describes PIC 6 controls in detail.

⚠ CAUTION

UNIT DAMAGE HAZARD

This unit uses a microprocessor-based electronic control system. **Do not** use jumpers or other tools to short out components or to bypass or otherwise depart from recommended procedures. Any short-to-ground of the control board or accompanying wiring may destroy the electronic modules or electrical components.

⚠ CAUTION

Do NOT punch holes or drill into the top surface of the starter enclosure for field wiring. Knockouts are provided for field wiring connections.

⚠ CAUTION

PROVIDE MACHINE PROTECTION. Store machine and starter indoors, protected from construction dirt and moisture and if required follow Carrier Long Term Storage guidelines. Inspect under shipping tarps, bags, or crates to be sure water has not collected during transit. Keep protective shipping covers in place until machine is ready for installation.

⚠ CAUTION

Be aware of electrostatic discharge (static electricity) when handling or making contact with circuit boards or module connections. Always touch a chassis (grounded) part to dissipate body electrostatic charge before working inside control center.

Use extreme care when handling tools near boards and when connecting or disconnecting terminal plugs. Circuit boards can easily be damaged. Always hold boards by the edges and avoid touching components and connections.

This equipment uses, and can radiate, radio frequency energy. If not installed and used in accordance with the instruction manual, it may cause interference to radio communications. The PIC 6 control boards have been tested and found to comply with the limits for a Class A computing device pursuant to International Standard in North America EN 61000-2/3 which are designed to provide reasonable protection against such interference when operated in a commercial environment. Operation of this equipment in a residential area is likely to cause interference, in which case the user, at his own expense, will be required to take whatever measures may be required to correct the interference.

Always store and transport replacement or defective boards in anti-static shipping bag.

⚠ CAUTION

WHEN FLUSHING THE WATER SYSTEMS isolate the chiller from the water circuits to prevent damage to the heat exchanger tubes.

ABBREVIATIONS AND EXPLANATIONS

Frequently used abbreviations in this manual include:

CCN	— Carrier Comfort Network®
ECDW	— Entering Condenser Water
ECW	— Entering Chilled Water
EMS	— Energy Management System
HGBP	— Hot Gas Bypass
HMI	— Human Machine Interface
I/O	— Input/Output
ISM	— Integrated Starter Module
LCDW	— Leaving Condenser Water
LCW	— Leaving Chilled Water
LED	— Light-Emitting Diode
OLTA	— Overload Trip Amps
PIC 6	— Product Integrated Controls 6
RLA	— Rated Load Amps
SCR	— Silicon Controlled Rectifier
TXV	— Thermostatic Expansion Valve
VFD	— Variable Frequency Drive

Factory-installed additional components are referred to as options in this manual; factory-supplied but field-installed additional components are referred to as accessories.

CHILLER FAMILIARIZATION (Fig. 1-5)

Chiller Information Nameplate

The information nameplate is located on the right side of the chiller control panel.

System Components

The components include cooler and condenser heat exchangers in separate vessels, motor-compressor, lubrication package, control panel/HMI, power panel, economizer, and motor starter or VFD.

Cooler

This vessel (also known as the evaporator) is located underneath the compressor. The cooler is maintained at lower temperature/pressure so evaporating refrigerant can remove heat from water flowing through its internal tubes.

Condenser

The condenser operates at a higher temperature/pressure than the cooler and has water flowing through its internal tubes in order to remove heat from the refrigerant.

Motor-Compressor

This component maintains system temperature and pressure differences and moves the heat-carrying refrigerant from the cooler to the condenser. The 19XR compressor frames 2, 3, 4, and 5 are single-stage compressors with one impeller. Frame C, E, 6, and 7 are two-stage compressors with two impellers.

Control Panel

The control panel includes the Carrier PIC 6 HMI touchscreen. It allows user interface for controlling the chiller. It regulates the chiller's capacity as required to maintain proper leaving chilled water temperature. The control panel:

- registers cooler, condenser, and lubricating system pressures
- shows chiller operating condition and alarm shutdown conditions
- records the total chiller operating hours
- sequences chiller start, stop, and recycle under microprocessor control
- displays status of motor starter
- provides access to other CCN (Carrier Comfort Network®) devices and energy management systems
- supports languages that may be preinstalled at factory, including English, Chinese, Korean, Italian, Japanese, French, and German.

Power Panel (19XR2-E)

The power panel contains oil heater and oil pump contactors, as well as the envelope control/HGBP relay if specified. The power panel also contains transformers T1/T2 for 24 VAC control power, as well as the low voltage starter interlock and communication terminals.

Power Panel (19XR6/7)

The control panel contains both power components for heaters, oil pump and electrical actuators as well as low voltage control components. They are separated by a barrier.

Economizer (if available)

This chamber reduces the refrigerant pressure to an intermediate level between the cooler and condenser vessels. In the economizer, vapor is separated from liquid, the separated vapor flows to the second stage of the compressor, and the liquid flows into the cooler. The energy removed from the vaporized refrigerant in the economizer allows the liquid refrigerant in

the cooler to absorb more heat when it evaporates and benefits the overall cooling efficiency cycle.

Free-Standing/Factory-Mounted Starter or VFD

The starter or VFD allows for the proper start and disconnect of electrical energy for the compressor-motor, oil pump, oil heater, and control panel.

Storage Vessel (Optional)

There are 2 sizes of storage vessels available. The vessels have double relief valves, a magnetically-coupled dial-type refrigerant level gage, a 1 in. FPT drain valve, and a 1/2-in. male flare vapor connection for the pumpout unit.

NOTE: If a storage vessel is not used at the jobsite, factory installed isolation valves on the chiller may be used to isolate the chiller charge in either the cooler or condenser. An optional pumpout system is used to transfer refrigerant from vessel to vessel.

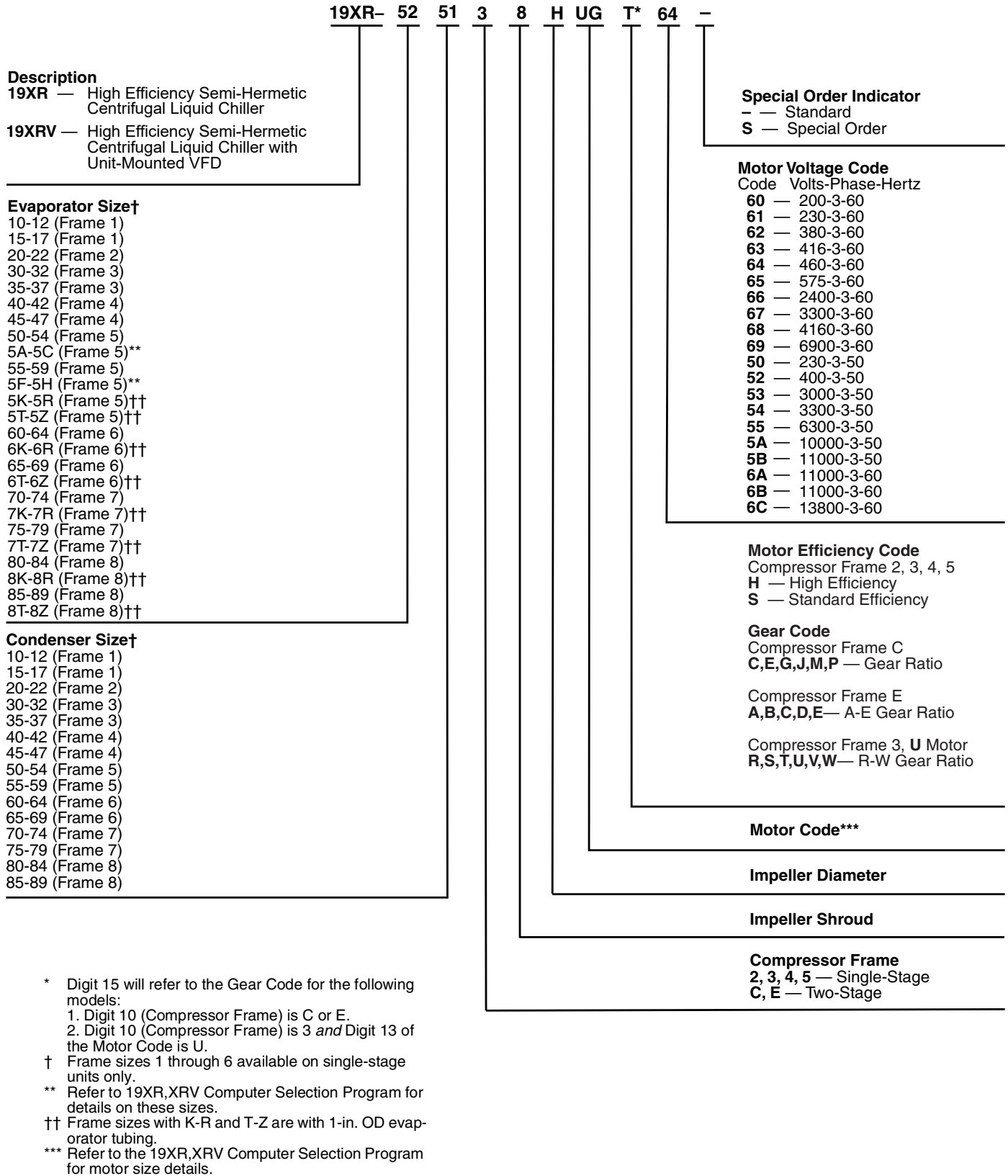

* Digit 15 will refer to the Gear Code for the following models:
1. Digit 10 (Compressor Frame) is C or E.
2. Digit 10 (Compressor Frame) is 3 and Digit 13 of the Motor Code is U.

† Frame sizes 1 through 6 available on single-stage units only.

** Refer to 19XR,XRV Computer Selection Program for details on these sizes.

†† Frame sizes with K-R and T-Z are with 1-in. OD evaporator tubing.

*** Refer to the 19XR,XRV Computer Selection Program for motor size details.

Fig. 1 — 19XR,XRV Single-stage Compressor and Two-stage Compressor Frame Size C and E

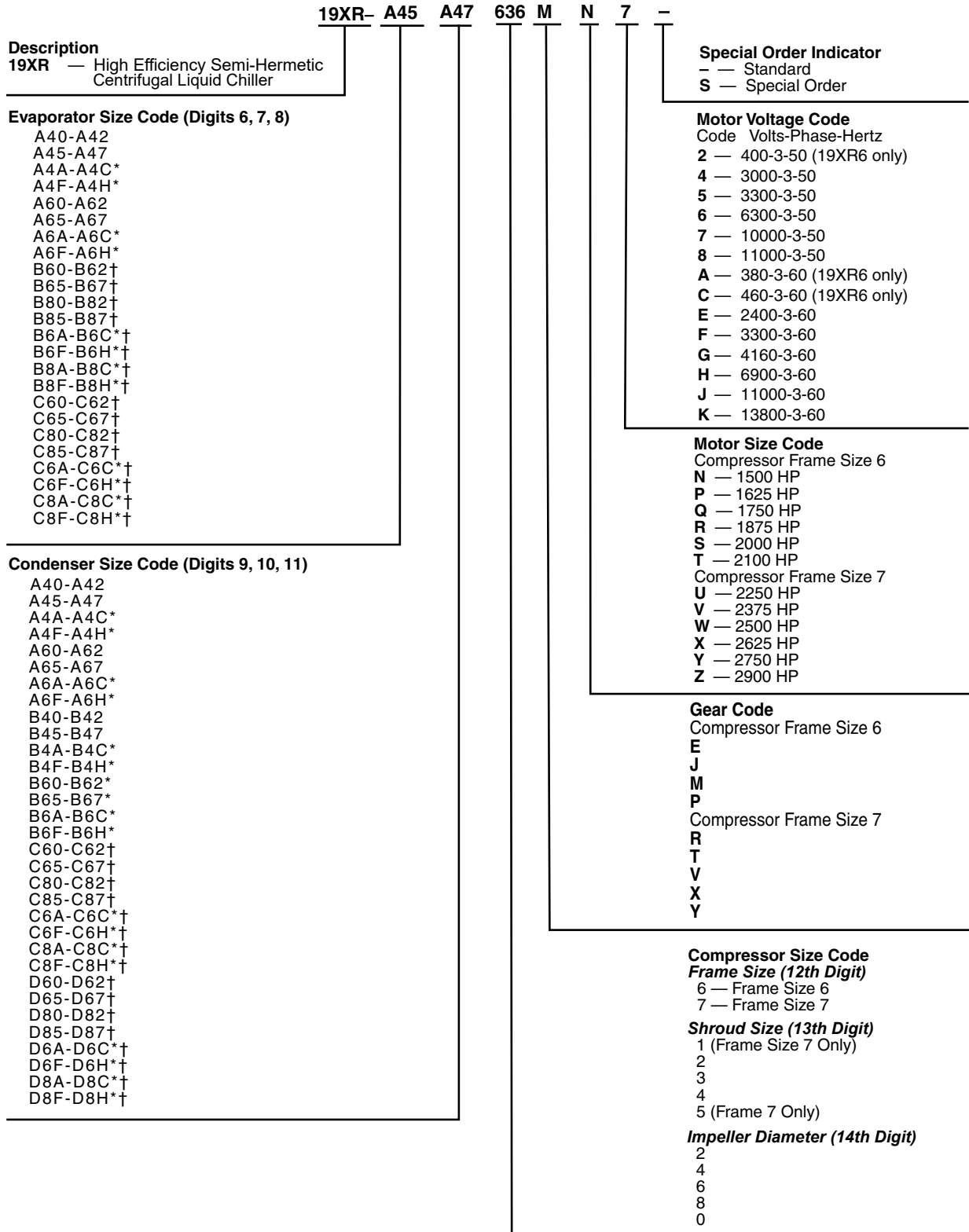

SERIAL NUMBER BREAKDOWN

* Frame sizes with A-C and F-H are with 1-in. OD tubing.
†Heat exchanger available with frame 7 compressor only.

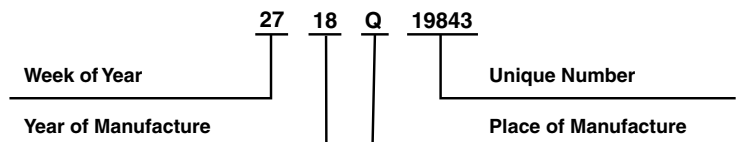
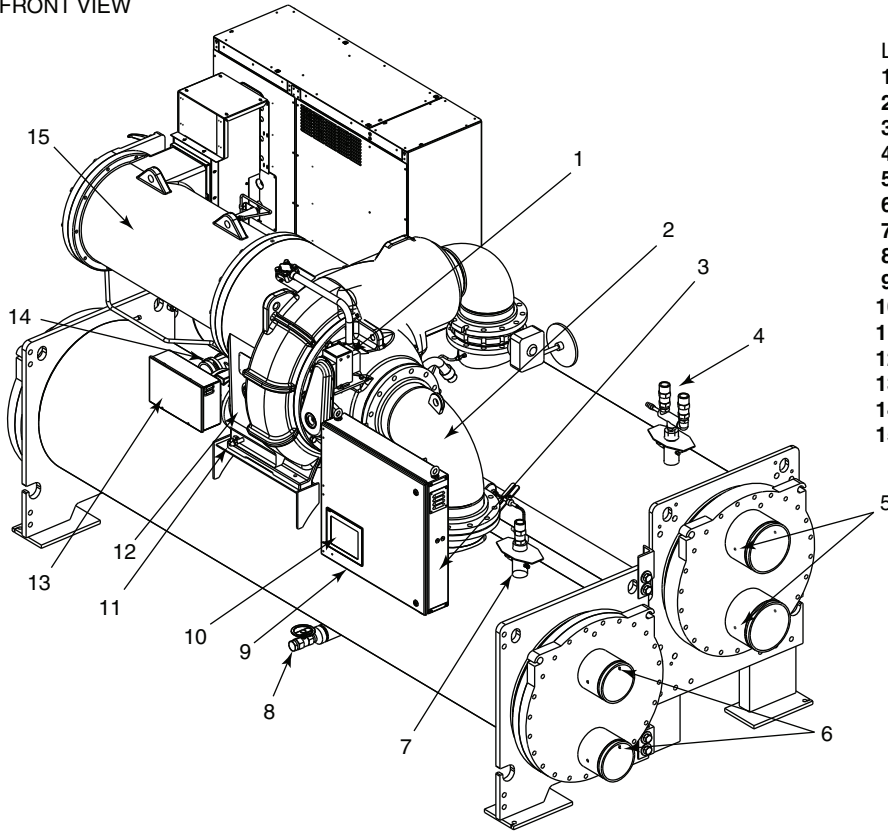

Fig. 2 — 19XR Two-Stage Compressor Frame Size 6 and 7

FRONT VIEW



LEGEND

- 1 — Guide Vane Actuator
- 2 — Suction Elbow
- 3 — Chiller Identification Nameplate
- 4 — Condenser Dual Relief Valves
- 5 — Condenser In/Out Temperature Thermistors
- 6 — Evaporator In/Out Temperature Thermistors
- 7 — Evaporator Pressure Transducer
- 8 — Refrigerant Storage Tank Connection
- 9 — Control Panel
- 10 — Carrier Controller HMI
- 11 — Oil Drain/Charger Valve
- 12 — Oil Level Sightglass
- 13 — Power Panel
- 14 — Refrigerant Oil Cooler (not shown)
- 15 — Compressor Motor Housing

REAR VIEW

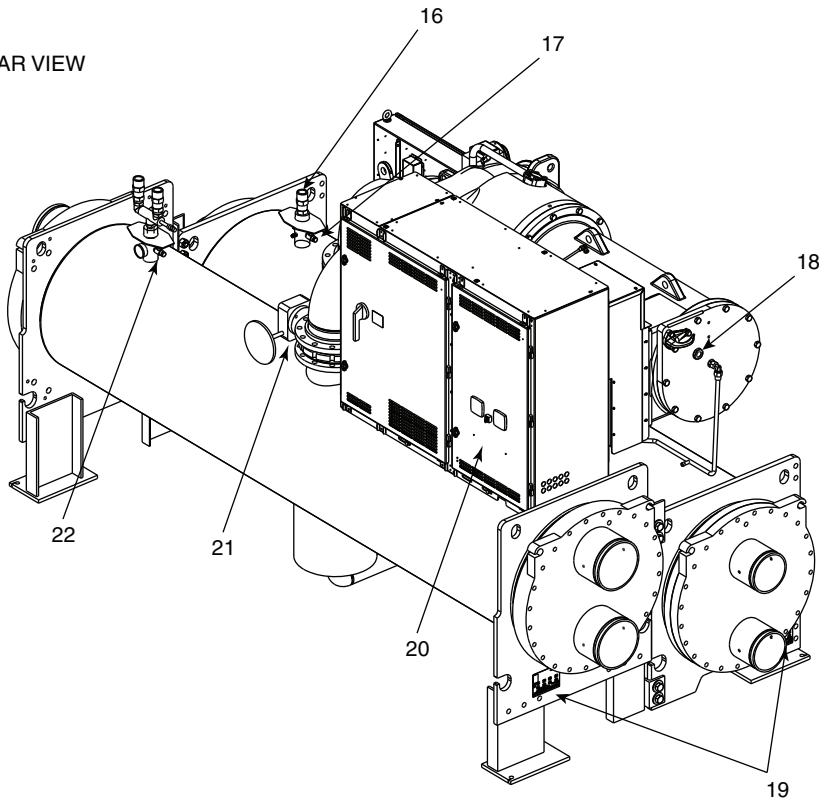

LEGEND

- 16 — Evaporator Relief Valve
- 17 — Refrigerant Charging Valve
- 18 — Motor Sightglass
- 19 — ASME Nameplates
- 20 — Starter/VFD
- 21 — Discharge Isolation Valve (Optional)
- 22 — Refrigerant Charging Valve/
Pump Out Connection

Fig. 3 — 19XR, XRV Single-Stage Compressor, Frame Size 2, 3, 4, 5

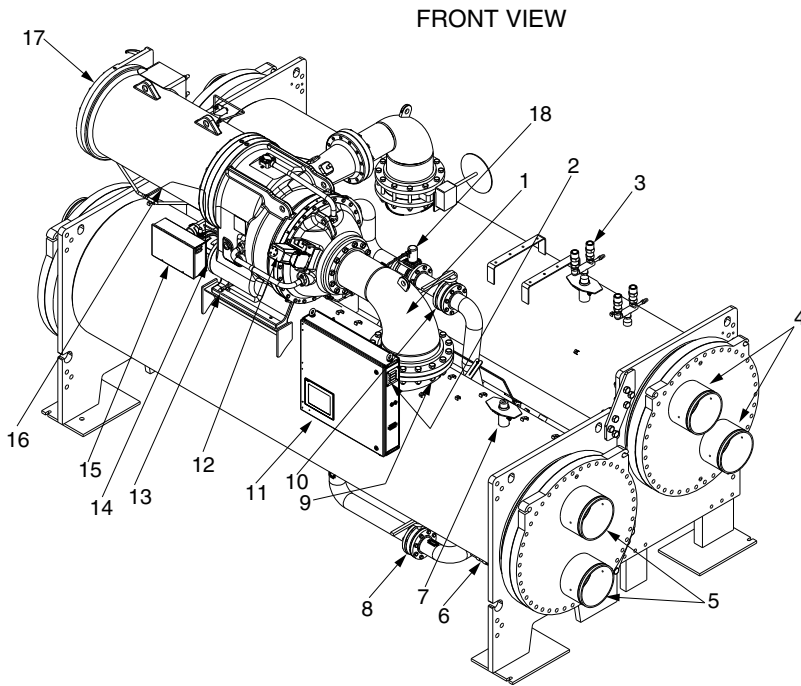

LEGEND

- 1 — Suction Elbow
- 2 — Chiller Identification Nameplate
- 3 — Condenser Auto Reset Relief Valves
- 4 — Condenser In/Out Temperature Thermistors
- 5 — Evaporator In/Out Temperature Thermistors
- 6 — Refrigerant Storage Tank Connection Valve (barely visible)
- 7 — Evaporator Pressure Transducer
- 8 — Liquid Line Isolation Valve (optional)
- 9 — Typical Flange Connection
- 10 — Refrigerant Isolation Valve
- 11 — Control Panel (PIC 6)
- 12 — Guide Vane Actuator
- 13 — Oil Level Sight Glasses
- 14 — Oil Drain Charging Valve
- 15 — Auxiliary Power Panel
- 16 — Refrigerant Oil Evaporator (hidden)
- 17 — Compressor Motor Housing

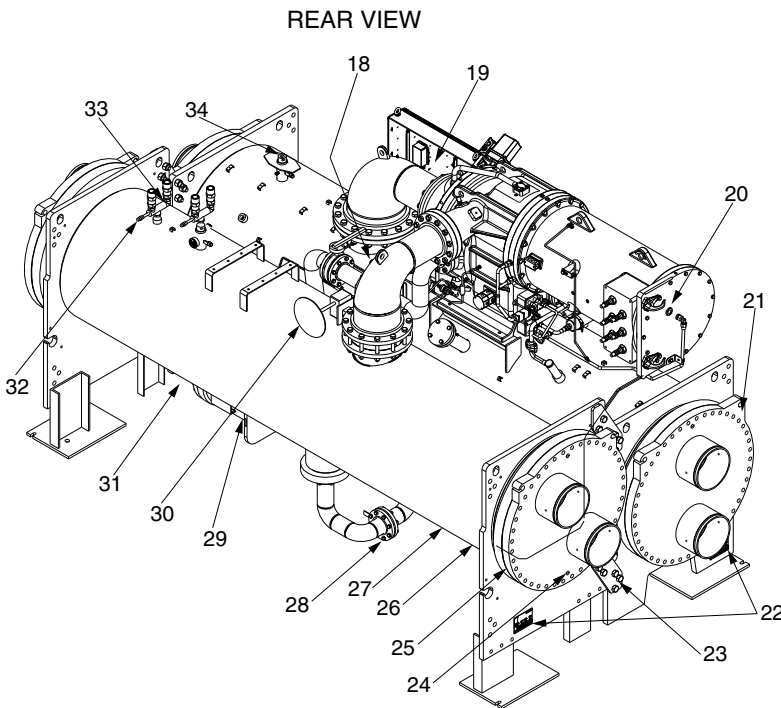

LEGEND

- 18 — Refrigerant Charging Valve/Pumpout Connection
- 19 — Damper Valve
- 20 — Evaporator Auto. Reset Relief Valves
- 21 — Solid-State Starter Control Display (optional)
- 22 — Motor Sight Glass
- 23 — Evaporator Return-End Waterbox Cover
- 24 — ASME Nameplate
- 25 — Vessel Take-Apart Connector
- 26 — Typical Waterbox Drain Port
- 27 — Condenser Return-End Waterbox Cover
- 28 — Refrigerant Moisture/Flow Indicator (hidden)
- 29 — Refrigerant Filter/Drier (hidden)
- 30 — Linear Float Valve Chamber Orifice
- 31 — Economizer Assembly
- 32 — Discharge Isolation Valve (optional)
- 33 — Economizer Float Ball Valve Assembly (far end of economizer assembly)
- 34 — Condenser Pressure Transducer

Fig. 4 — 19XR, XRV Two-Stage Compressor Frame Size C and E

FRONT VIEW

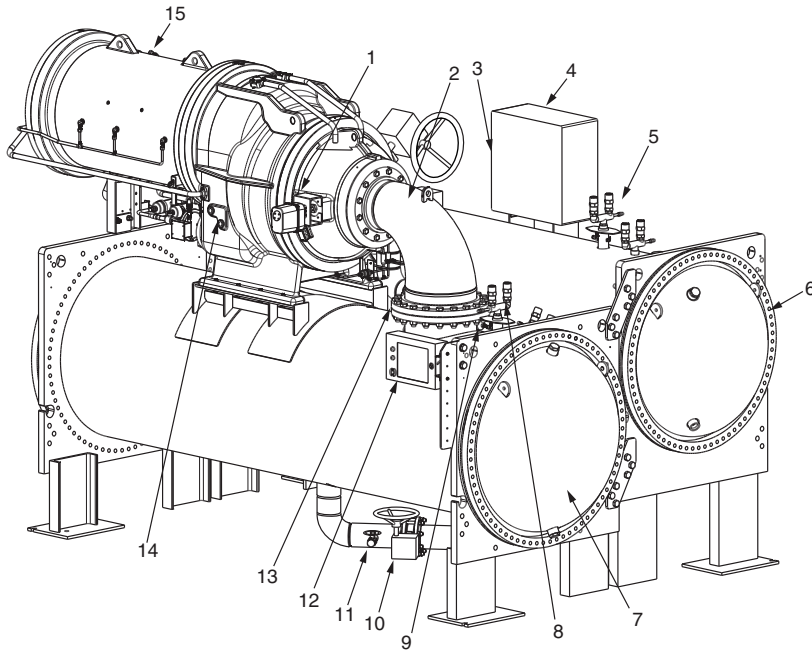

LEGEND

- 1 — Guide Vane Actuator*
- 2 — Suction Elbow
- 3 — Chiller Identification Nameplate
- 4 — Auxiliary Power Panel
- 5 — Condenser Auto. Reset Relief Valves
- 6 — Condenser Return End Waterbox Cover
- 7 — Evaporator Return End Waterbox Cover
- 8 — Evaporator Auto. Reset Relief Valves
- 9 — Evaporator Pressure Transducer
- 10 — Liquid Line Isolation Valve (Optional)
- 11 — Refrigerant Storage Tank Connection Valve
- 12 — HMI (Human Machine Interface) Panel
- 13 — Typical Flange Connection
- 14 — Oil Level Sight Glasses
- 15 — Compressor Motor Housing

*See certified drawing for Frame 7 location.

REAR VIEW

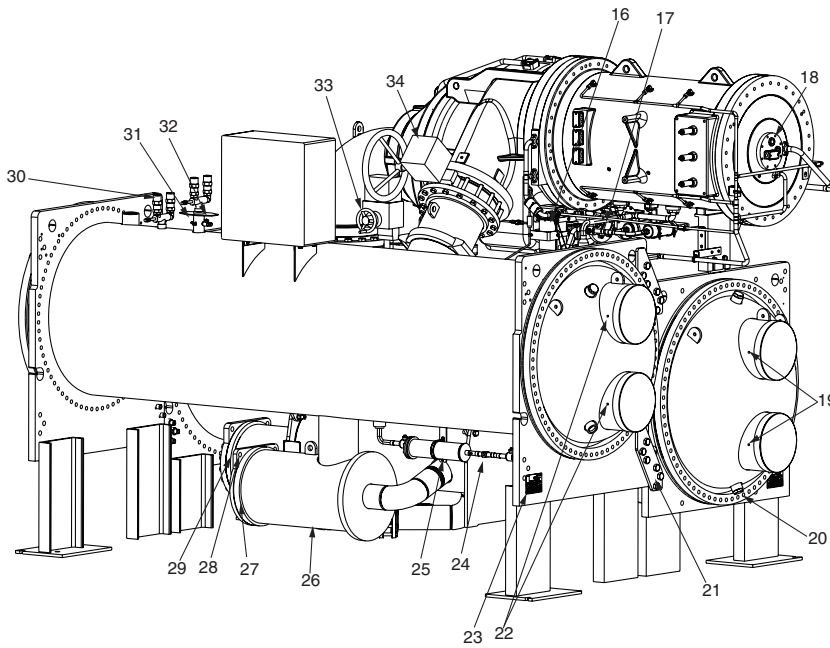

LEGEND

- 16 — Oil Evaporator
- 17 — Oil Drain Changing Valve (Hidden)
- 18 — Motor Sight Glass
- 19 — Evaporator In/Out Temperature Thermistors
- 20 — Typical Waterbox Drain Port
- 21 — Vessel Take-Apart Connector
- 22 — Condenser In/Out Temperature Thermistors
- 23 — ASME Nameplate
- 24 — Refrigerant Moisture/Flow Indicator
- 25 — Refrigerant Filter/Drier
- 26 — High Side Float Chamber
- 27 — High Side Float Ball Valve Assembly (Inside)
- 28 — Economizer Assembly
- 29 — Economizer Float Ball Assembly (Inside)
- 30 — Evaporator Auto. Reset Relief Valve
- 31 — Condenser Pressure Transducer
- 32 — Refrigerant Charging Valve/Pumpout Connection
- 33 — Damper Valve
- 34 — Discharge Isolation Valve (Optional)

NOTE: Frame 6 is shown.

Fig. 5 — 19XR Two-Stage Compressor Frame Sizes 6 and 7

REFRIGERATION CYCLE

The compressor continuously draws refrigerant vapor from the cooler at a rate set by the amount of guide vane opening and motor speed. As the compressor suction reduces the pressure in the cooler, the remaining refrigerant boils at a fairly low temperature (typically 38 to 42°F [3 to 6°C]). The energy required for boiling is obtained from the water flowing through the cooler tubes. With heat energy removed, the water becomes cold enough to use in an air conditioning circuit or for process liquid cooling.

After taking heat from the water, the refrigerant vapor is compressed. Compression adds still more heat energy, and the refrigerant is quite warm (typically 98 to 102°F [37 to 40°C]) when it is discharged from the compressor into the condenser.

Relatively cool (typically 65 to 90°F [18 to 32°C]) water flowing into the condenser tubes removes heat from the refrigerant and the vapor condenses to liquid.

The liquid refrigerant passes through orifices into the FLASC (Flash Subcooler) chamber (Fig. 6 and 7). Since the FLASC chamber is at a lower pressure, part of the liquid refrigerant flashes to vapor, thereby cooling the remaining liquid. The FLASC vapor is re-condensed on the tubes which are cooled by entering condenser water. The liquid drains into a float valve chamber between the FLASC chamber and cooler. Here the AccuMeter™ float valve forms a liquid seal to keep

FLASC chamber vapor from entering the cooler. When liquid refrigerant passes through the valve, some of it flashes to vapor in the reduced pressure on the cooler side. In flashing, it removes heat from the remaining liquid. The refrigerant is now at a temperature and pressure at which the cycle began. Refrigerant from the condenser also cools the oil and optional variable speed drive.

The refrigeration cycle for a 19XRV chiller with two-stage compressor is similar to the one described above, with the following exception: Liquid refrigerant from the condenser FLASC chamber linear float valve or orifice plate flows into an economizer at intermediate pressure (see Fig. 7). As liquid enters the chamber, due to the lower pressure in the economizer, some liquid flashes into a vapor and cools the remaining liquid. The separated vapor flows to the second stage of the compressor for greater cycle efficiency. A damper valve located on the economizer line to the compressor acts as a pressure regulating device to stabilize low load, low condensing pressure operating conditions. The damper will back up gas flow and thereby raise the economizer pressure to permit proper refrigerant flow through the economizer valve during those conditions. The damper also is closed during start-up conditions to allow the second stage impeller to start unloaded.

The subcooled liquid remaining in the economizer flows through a float valve and then into the cooler.

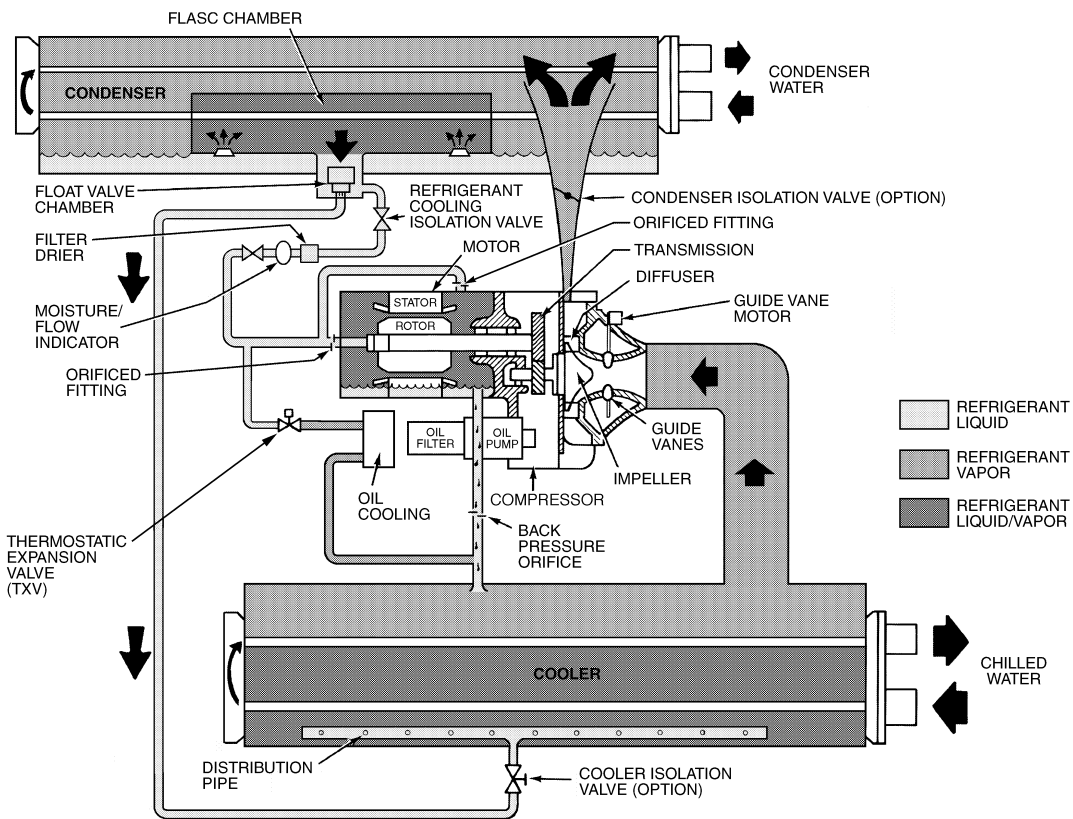

Fig. 6 — Refrigeration Cycle — 19XR(V) Single-Stage Compressor

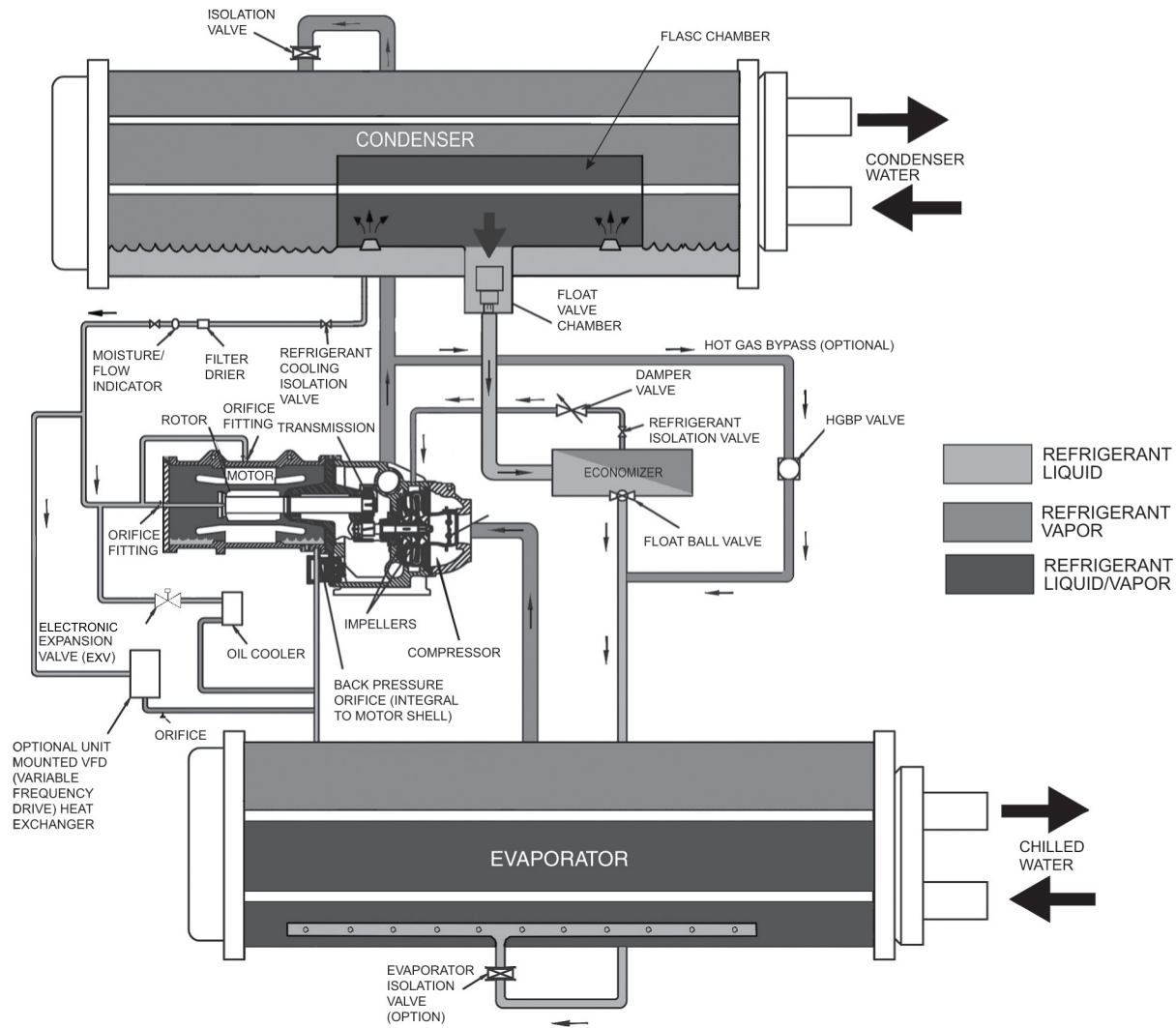

Fig. 7 — Refrigeration Cycle — 19XR(V) Two-Stage Compressor

MOTOR AND OIL COOLING CYCLE

The motor and the lubricating oil are cooled by liquid refrigerant taken from the bottom of the condenser vessel (Fig. 8 and 9). Refrigerant flow is maintained by the pressure differential that exists due to compressor operation. After the refrigerant flows past an isolation valve, an in-line filter, and a sight glass/moisture indicator, the flow is split between the motor cooling and oil cooling systems.

bottom of the motor casing and is then drained back into the cooler through the motor refrigerant drain line. An orifice (in the motor shell) maintains a higher pressure in the motor shell than in the cooler. The motor is protected by a temperature sensor embedded in the stator windings. An increase in motor winding temperature past the motor override set point overrides the temperature capacity control to hold, and if the motor temperature rises 10°F (5.5°C) above this set point, the controls close the inlet guide vanes. If the temperature rises above safety limit, the compressor shuts down.

Refrigerant that flows to the oil cooling system is regulated by expansion valves. The expansion valves regulate flow into the oil/refrigerant plate and frame-type heat exchanger (the oil cooler in Fig. 8), and control oil temperature to the bearings. The refrigerant leaving the oil cooler heat exchanger returns to the chiller cooler.

VFD Cooling Cycle

If equipped with a refrigerant-cooled unit-mounted VFD, the refrigerant line that feeds the motor cooling and oil cooler also feeds the heat exchanger on the unit-mounted VFD. Refrigerant is metered through an orifice as refrigerant is leaving the VFD heat exchanger. The refrigerant leaving the heat exchanger returns to the cooler. Alternatively, if equipped with an air-cooled unit-mounted VFD the cooling of the VFD is integral to the VFD by means of cooling with ambient air.

CAUTION

To avoid adverse effects on chiller operation, consideration must be made to condenser water temperature control. For steady state operation, the minimum operating refrigerant pressure differential between cooler and condenser is approximately 20 psi (138 kPa) with a maximum evaporator refrigerant temperature of 65°F (18°C). Consult Chiller Builder for required steady state operational limits. Inverted start conditions are acceptable for short durations of time, but for periods exceeding 5 minutes, a special control solution strategy should be used to allow the chiller to establish a minimum refrigerant pressure differential, and thereby adequate equipment cooling.

Flow to the motor cooling system passes through an orifice and into the motor. Once past the orifice, the refrigerant is directed over the motor by spray nozzles. The refrigerant collects in the

LUBRICATION CYCLE

Summary

The oil pump, oil filter, and oil cooler make up a package located partially in the transmission casing of the compressor-motor assembly. The oil is pumped into a filter assembly to remove foreign particles and is then forced into an oil cooler heat exchanger where the oil is cooled to proper operational temperatures. After the oil cooler, part of the flow is directed to the gears and the high speed shaft bearings; the remaining flow is directed to the motor shaft bearings. Oil drains into the transmission oil sump to complete the cycle (Fig. 8 and 9).

Details

Oil is charged into the lubrication system through a hand valve. Two sight glasses in the oil reservoir permit oil level observation. Normal oil level is between the middle of the upper sight glass and the top of the lower sight glass when the compressor is shut down. The oil level should be visible in at least one of the 2 sight glasses during operation. Oil sump temperature is displayed on the HMI default screen. During compressor operation, the oil sump temperature ranges between 125 and 165°F (52 and 74°C).

The oil pump suction is fed from the oil reservoir. An oil pressure relief valve maintains differential pressure in the system at the pump discharge. A range of 18 to 40 psid (124 to 172 kPad) is normal. This differential pressure can be read directly from the default HMI screen. The oil pump discharges oil to the oil filter assembly. This filter can be closed to permit removal of the filter without draining the entire oil system. The oil is then piped to the oil cooler heat exchanger. The oil cooler uses refrigerant from the condenser as the coolant. The refrigerant cools the oil to a temperature between 120 and 140°F (49 and 60°C).

As the oil leaves the oil cooler, it passes the oil pressure transducer and the sensor for the refrigerant expansion valve on the oil cooler. The oil is then divided. Part of the oil flows to the thrust bearing, forward pinion bearing, and gear spray. The rest of the oil lubricates the motor shaft bearings and the rear pinion bearing. The oil temperature is measured in the bearing housing as it leaves the bearings. The oil then drains into the oil reservoir at the base of the compressor. The control measures the temperature of the oil in the sump and maintains the temperature during shutdown. This temperature is read on the HMI default screen. See the Controls Operation and Troubleshooting Manual for details.

During the chiller start-up, the oil pump is energized and provides 40 seconds of lubrication to the bearings after pressure is verified before starting the compressor. During shutdown, the oil pump runs for 60 seconds to ensure lubrication as the compressor coasts to a stop.

Ramp loading can be adjusted to help to slow the rate of guide vane opening to minimize oil foaming at start-up. If the guide vanes open quickly, the sudden drop in suction pressure can cause any refrigerant in the oil to flash. The resulting oil foam cannot be pumped efficiently; therefore, oil pressure falls off and lubrication is poor. If oil pressure falls below 15 psid (103 kPad) differential, the controls will shut down the compressor.

The oil pump is a gerotor-style pump with external filters. A gerotor pump has two rotors, one inside the other; their center points are offset with respect to each other. This type of pump provides a smooth continuous flow. It is also quieter than other designs. See Fig. 10 and 11.

Bearings

The 19XR compressor assemblies include a combination of radial and thrust bearings. The low speed shaft assembly is supported by two journal bearings. For 19XR2-E the bearings are located between the motor rotor and the bull gear — overhung rotor design. The 19XR6-7 is fully supported with bearings located on each end of the low speed shaft. The bearing closer to the bull gear includes a smaller babbitted thrust face, designed to handle axial forces.

For Frame 2 19XR compressors the high speed shaft assembly is supported by two journal bearings located at the transmission end and mid-span, behind the labyrinth seal. The transmission side of the midspan bearing also contains a tilting shoe type thrust bearing which opposes the main axial forces tending to pull the impeller towards the suction end. The impeller side face of the midspan bearing includes a babbitted thrust face, designed to handle counter-thrust forces.

For 19XR Frame 3, 4, 5, C, E, 6 and 7 compressors the high speed shaft assembly utilize rolling element bearings (radial and thrust).

Machines employing rolling element bearings can be expected to have higher oil pressure and thrust bearing temperatures than those compressors using journal bearing design.

Oil Reclaim System

The oil reclaim system returns oil lost from the compressor housing back to the oil reservoir by recovering the oil from 2 areas on the chiller. The guide vane housing is the primary area of recovery. Oil is also recovered by skimming it from the operating refrigerant level in the cooler vessel.

PRIMARY OIL RECOVERY MODE

Oil is normally recovered through the guide vane housing on the chiller. This is possible because oil is normally entrained with refrigerant in the chiller. As the compressor pulls the refrigerant up from the cooler into the guide vane housing to be compressed, the oil normally drops out at this point and falls to the bottom of the guide vane housing where it accumulates. Using discharge gas pressure to power an eductor, the oil is drawn from the housing and is discharged into the oil reservoir.

SECONDARY OIL RECOVERY METHOD

The secondary method of oil recovery is significant under light load conditions, when the refrigerant going up to the compressor suction does not have enough velocity to bring oil along. Under these conditions, oil collects in a greater concentration at the top level of the refrigerant in the cooler. Using discharge gas to power eductors, this oil and refrigerant mixture is skimmed from the side of the cooler and is then drawn up to the guide vane housing. There is a filter in this line. Because the guide vane housing pressure is much lower than the cooler pressure, the refrigerant boils off, leaving the oil behind to be collected by the primary oil recovery method.

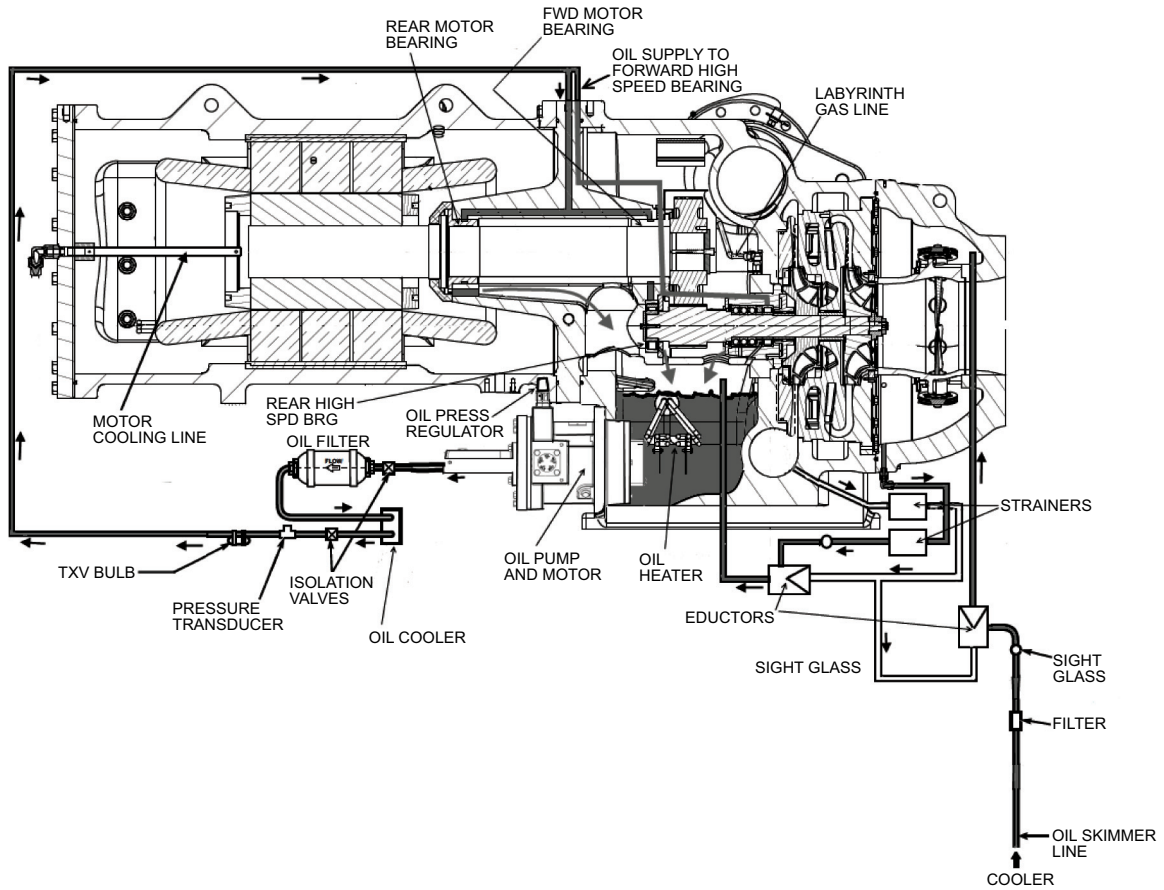

Fig. 8 — 19XR2-E Compressor Lubrication System

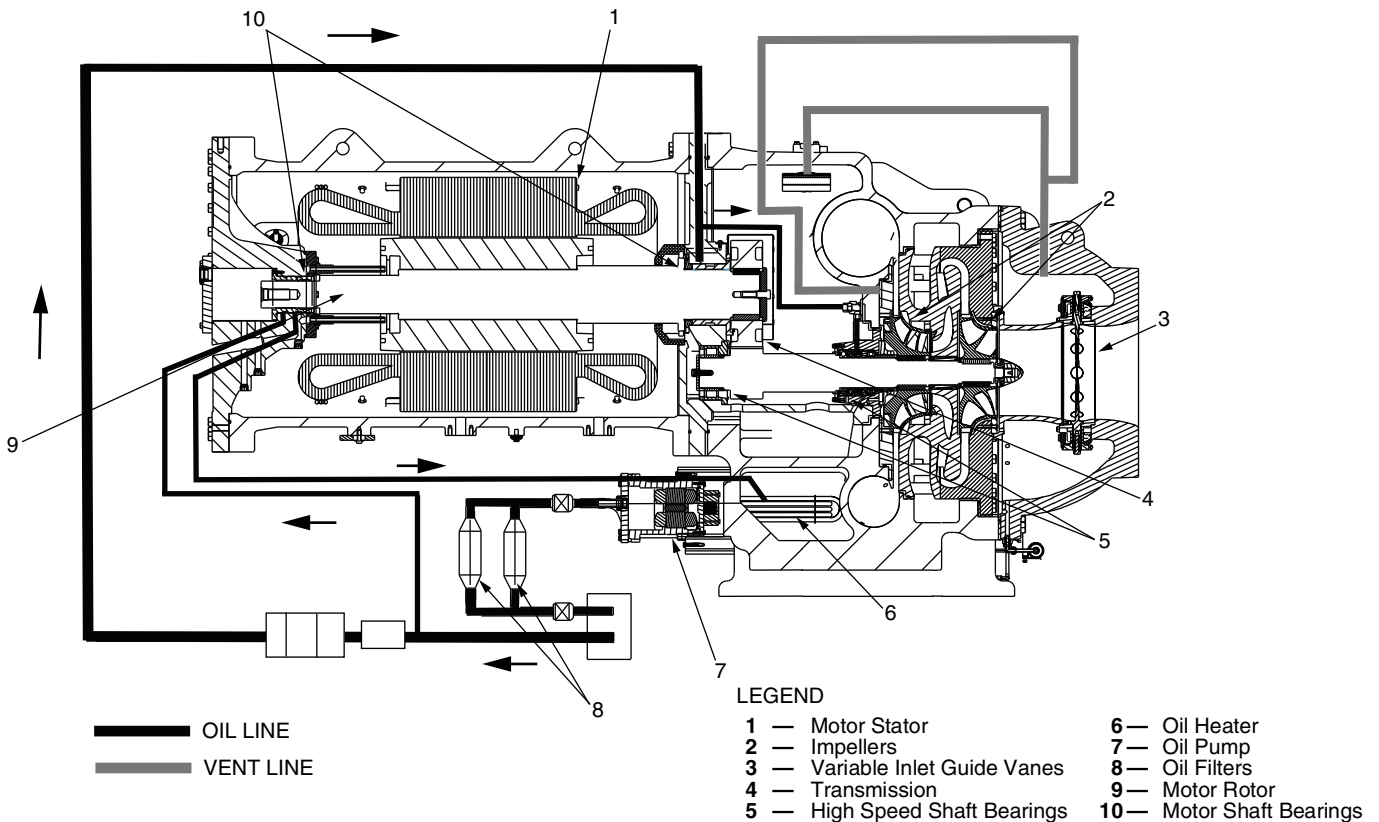
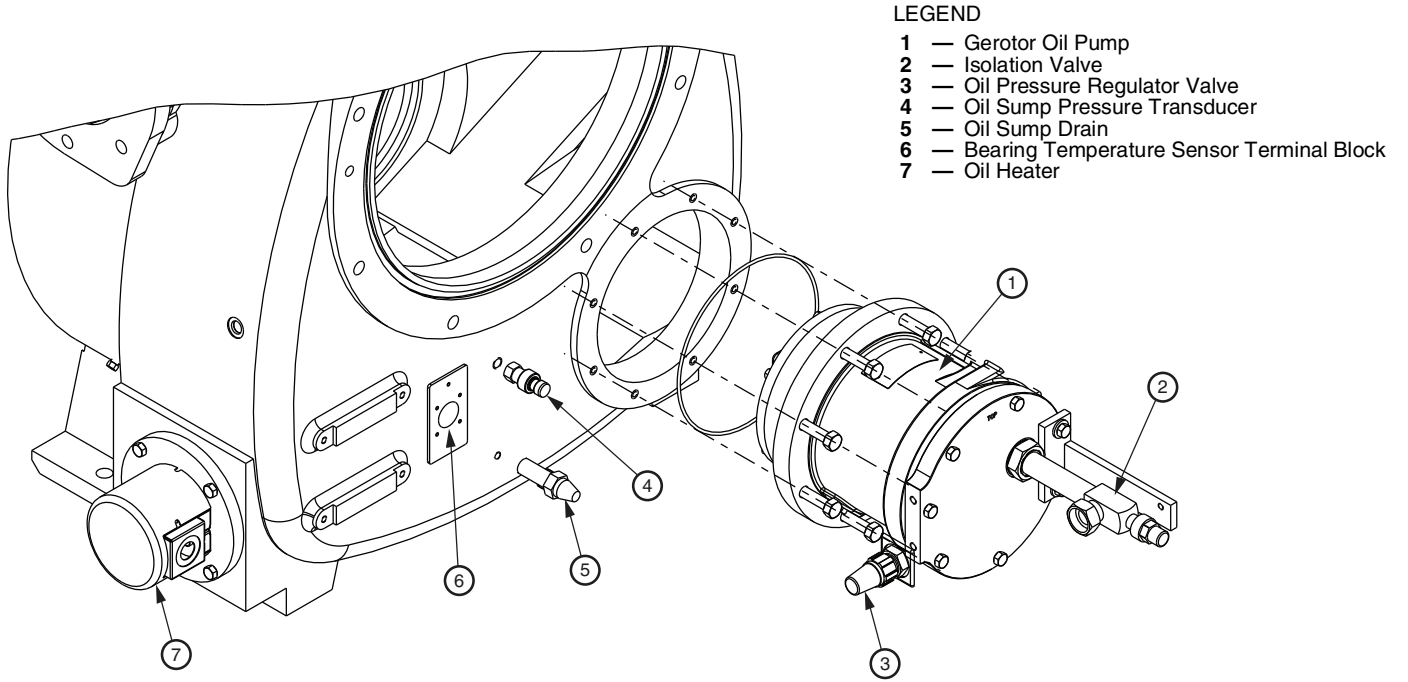

Fig. 9 — 19XR6-7 Compressor Lubrication System



LEGEND

- 1 — Gerotor Oil Pump
- 2 — Isolation Valve
- 3 — Oil Pressure Regulator Valve
- 4 — Oil Sump Pressure Transducer
- 5 — Oil Sump Drain
- 6 — Bearing Temperature Sensor Terminal Block
- 7 — Oil Heater

Fig. 10 — 19XR2-E Gerotor Oil Pump

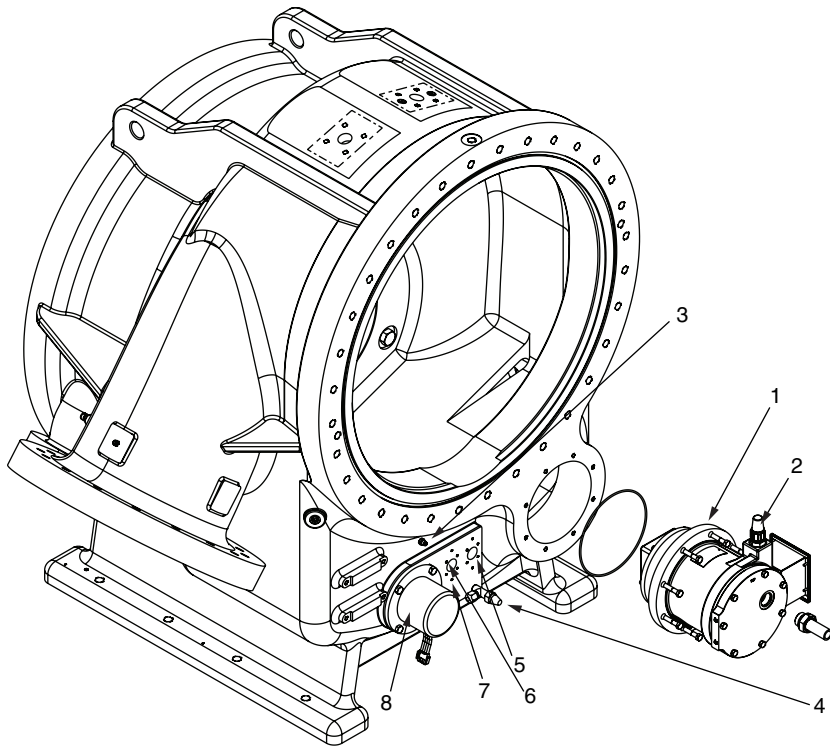

LEGEND

- 1 — Gerotor Oil Pump
- 2 — Oil Pressure Regulator Valve
- 3 — Oil Sump Pressure Transducer
- 4 — Oil Sump Drain Valve
- 5 — High Speed Compressor End Bearing and Low Speed Compressor End Bearing (Terminal Box #2)
- 6 — Low Speed Compressor End Bearing and High Speed Motor End Bearing (Terminal Box #1)
- 7 — Compressor Oil Sump Temperature
- 8 — Oil Heater

Fig. 11 — 19XR6-7 Gerotor Oil Pump

STARTING EQUIPMENT

The 19XR chiller requires a motor starter or VFD to operate the centrifugal hermetic compressor motor. The starter or VFD have communication wiring between itself and Carrier power panel (19XR2-E) or Carrier control panel (19XR6-7).

See Carrier's specifications for specific starter/VFD requirements. All starters/VFDs must meet these specifications in order to properly start and satisfy mechanical safety requirements.

There may be multiple circuit breakers inside the starter. These include the main compressor motor circuit breaker, a circuit breaker which provides power to the chiller control panel, and a possible circuit breaker for starter specific controls. The control breaker(s) are typically wired in parallel with the first so that power is provided to those services when the main breaker is open. The disconnect switch on the starter front cover is connected to the main breaker. For 19XR2-E units it is typical that the starter provides control power and if specified 3-phase power to the oil pump (for medium/high voltage there is an option for a transformer). For 19XR6-7 it is typical that 3-phase power is field supplied to the Carrier control panel which powers oil-pump, heater and controls. Consult specific wiring diagrams for details.

⚠ WARNING

The main circuit breaker on the front of the starter/VFD disconnects the main motor power only. Power may be still energized for other circuits. Always check wiring diagrams before initiating any work on the chiller and follow applicable lock-out/tag-out procedures. Failure to disconnect power will result in personal injury.

Unit-Mounted VFDs

The 19XR2-E starter options include a variable frequency drive motor controller mounted on the condenser. These unit-mounted VFDs are offered with low voltage motors between 380 and 575 vac. It reduces the starting current inrush by controlling the voltage and frequency to the compressor motor. Once the motor has accelerated to minimum speed, the PIC 6 modulates the compressor speed and guide vane position to control chilled water temperature.

Operational parameters and fault codes are displayed relative to the drive. Refer to specific drive literature along with troubleshooting sections (consult VFD nameplate on inside of door if uncertain of drive model). The display is also the interface for entering specific chiller operational parameters. These parameters have been preprogrammed at the factory. An adhesive-backed label on the inside of the drive has been provided for verification of the specific job parameters. See Initial Start-Up Checklist section for details.

NOTE: The factory offers a variety of unit-mounted VFDs. LiquiFlo2 is an active front end drive while PowerFlex 755, VLT HVAC FC-102, and PowerFlex 700L are 6-pulse passive rectifier drives. Consult Carrier Specification Z-420 and Z-417 respectively, along with drive-specific literature for details.

Unit-Mounted Starters

The 19XR2-E chiller offers unit-mounted wye-delta and solid state starters. See Carrier Specification Z-415 for specific starter requirements.

Typically three separate circuit breakers are inside the starter. This includes (1) the main compressor motor circuit breaker, (2) a circuit breaker which provides power to chiller controls and the oil heater (provided at 115 vac), and (3) a circuit breaker which provides power at line voltage to the oil pump. The latter two are typically wired in parallel with the first so that power is provided to those services when the main breaker is open. The disconnect switch on the starter front cover is connected to the main breaker.

Solid-State Starter

⚠ WARNING

The main circuit breaker on the front of the starter disconnects the main motor power only. Power is still energized for two other circuits. Two additional circuit breakers inside of the starter must be turned off to disconnect power to the oil pump, PIC 6 controls, and the oil heater. Failure to disconnect power will result in personal injury.

The 19XR chiller may be equipped with a solid-state, reduced voltage starter. This starter's primary function is to provide on-off control of the compressor motor. This type of starter reduces the peak starting torque, controls the motor inrush current, and decreases mechanical shock. This capability is summed up by the phrase "soft starting." Consult E-Cat for full information about starter offerings. The solid-state starter manufacturer's name is located inside the starter access door.

A solid-state, reduced-voltage starter operates by reducing the starting voltage. The starting torque of a motor at full voltage is typically 125% to 175% of the running torque. When the voltage and the current are reduced at start-up, the starting torque is reduced as well. The object is to reduce the starting voltage to adjust the voltage necessary to develop the torque required to get the motor moving. The voltage is reduced by silicon controlled rectifiers (SCRs). The voltage and current are then ramped up in a desired period of time. Once full voltage is reached, a bypass contactor is energized to bypass the SCRs.

⚠ WARNING

When voltage is supplied to the solid-state circuitry (CBI is closed), the heat sinks in the starter as well as the wires leading to the motor and the motor terminal are at line voltage. Do not touch the heat sinks, power wiring, or motor terminals while voltage is present or serious injury will result.

The display on the front of the solid-state or wye-delta starter is useful for troubleshooting and starter checkout. The display indicates:

- line voltage
- control voltage status
- power indication
- proper phasing for rotation
- start circuit energized
- ground fault
- current unbalance
- run state

Wye-Delta Starter

The 19XR chiller may be equipped with a wye-delta starter mounted on the unit. This starter is used with low-voltage motors (under 600 v). It reduces the starting current inrush by connecting each phase of the motor windings into a wye configuration. This occurs during the starting period when the motor is accelerating up to speed. Once the motor is up to speed, the starter automatically connects the phase windings into a delta configuration. When connected in delta the currents through the motor windings is $1/\sqrt{3}$ (57.7%) of line current.

Additional information about current unit-mounted starters can be located as follows:

Benshaw MX³ Low Voltage Solid-State Starter Manual - HVACPartners Form Number = 890003-06-01

Benshaw MX³ Low Voltage Wye-Delta Starter Manual - HVACPartners Form Number = 890003-07-02

Free-Standing Starters/VFDs

In addition to unit-mounted starters the 19XR product line offers free-standing starter types of Across the Line, Solid State, Auto-Transformer and VFD. 19XR6-7 are only offered with free-standing starters/VFDs. For free-standing starters/VFDs refer to job submittal drawings.

CONTROLS

Definitions

ANALOG SIGNAL

An *analog signal* varies in proportion to the monitored source. It quantifies values between operating limits. (Example: A temperature sensor is an analog device because its resistance changes in proportion to the temperature, generating many values.)

DISCRETE SIGNAL

A *discrete signal* is a 2-position representation of the value of a monitored source. (Example: A switch produces a discrete signal indicating whether a value is above or below a set point or boundary by generating an on/off, high/low, or open/closed signal.)

General

The 19XR centrifugal liquid chiller contains a microprocessor-based control center that monitors and controls all operations of the chiller. The microprocessor control system matches the cooling capacity of the chiller to the cooling load while providing state-of-the-art chiller protection. The system controls cooling load within the set point plus the deadband by sensing the leaving chilled water or brine temperature and regulating the inlet guide vane via a mechanically linked actuator motor. The guide vane is a variable flow pre-whirl assembly that controls the refrigeration effect in the cooler by regulating the amount of refrigerant vapor flow into the compressor. An increase in guide vane opening increases capacity. A decrease in guide vane opening decreases capacity. Additionally if a unit is equipped with VFD then the controller will control both compressor speed and guide vane for optimum efficiency at a particular load. The microprocessor-based control center protects the chiller by monitoring the digital and analog inputs and executing capacity overrides or safety shutdowns, if required.

PIC 6 System Components

The chiller control system is called the PIC 6 (Product Integrated Control 6). See Table 1. As with previous PIC versions, the PIC 6 system controls the operation of the chiller by monitoring all operating conditions. The PIC 6 control system can diagnose a problem and let the operator know what the problem is and what to check. It positions the guide vanes to maintain leaving chilled water temperature. It interfaces with auxiliary equipment such as pumps and cooling tower fans to turn them on when required. It continually checks all safeties to prevent unsafe operating conditions. It also regulates the oil heater while the compressor is off and regulates the envelope control (HGBP) and any other automatic valves, if installed. The PIC 6 controls provide critical protection for the compressor motor and control the motor starter.

Table 1 — Major PIC 6 Components and Panel Locations

PIC 6 COMPONENT	PANEL LOCATION
Chiller Human Machine Interface (HMI) and Display	HMI Control Panel
Integrated Starter Module (ISM)	Starter Cabinet
Motor Starter Protection Module (e.g ISM, MX3 or drive control)	Starter/VFD dependent
Chiller IO Boards and Field Wiring Terminal Blocks	Control Panel
Oil Heater Contactor (1C)	19XR2-E; Power Panel 19XR6-7: Control Panel
Oil Pump Contactor (2C)	19XR2-E; Power Panel 19XR6-7: Control Panel
Hot Gas Bypass Relays (HCLR, HOPR) (Optional)	19XR2-E; Power Panel 19XR6-7: Control Panel
Control Transformers (T1, T2, T3)	19XR2-E; Power Panel 19XR6-7: Control Panel
Temperature Sensors	See Fig. 12 and Fig. 13
Pressure Transducers	See Fig. 12 and Fig. 13

NOTE: For detailed information about the PIC 6 HMI (human machine interface), see the 19XR with PIC 6 Controls Operation and Troubleshooting manual.

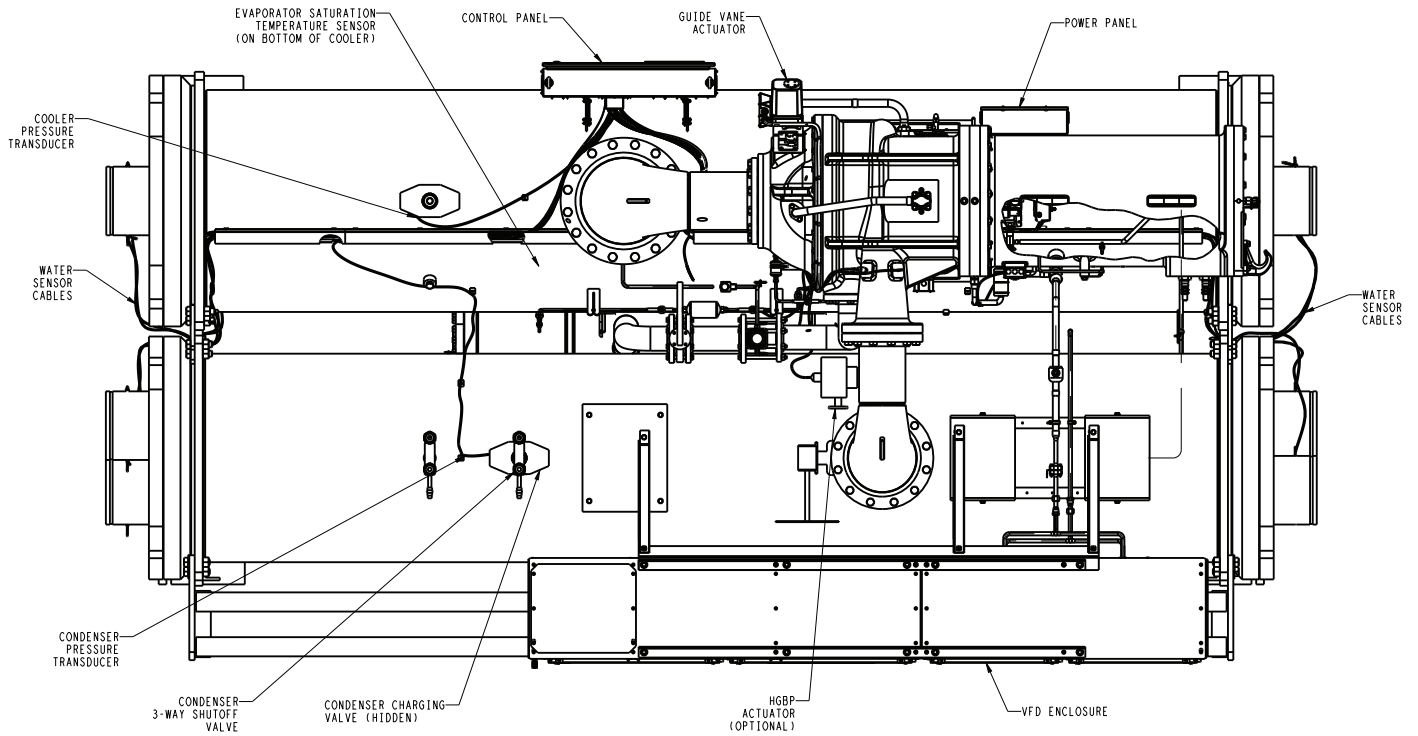

Fig. 12 — Chiller Controls and Sensor Locations

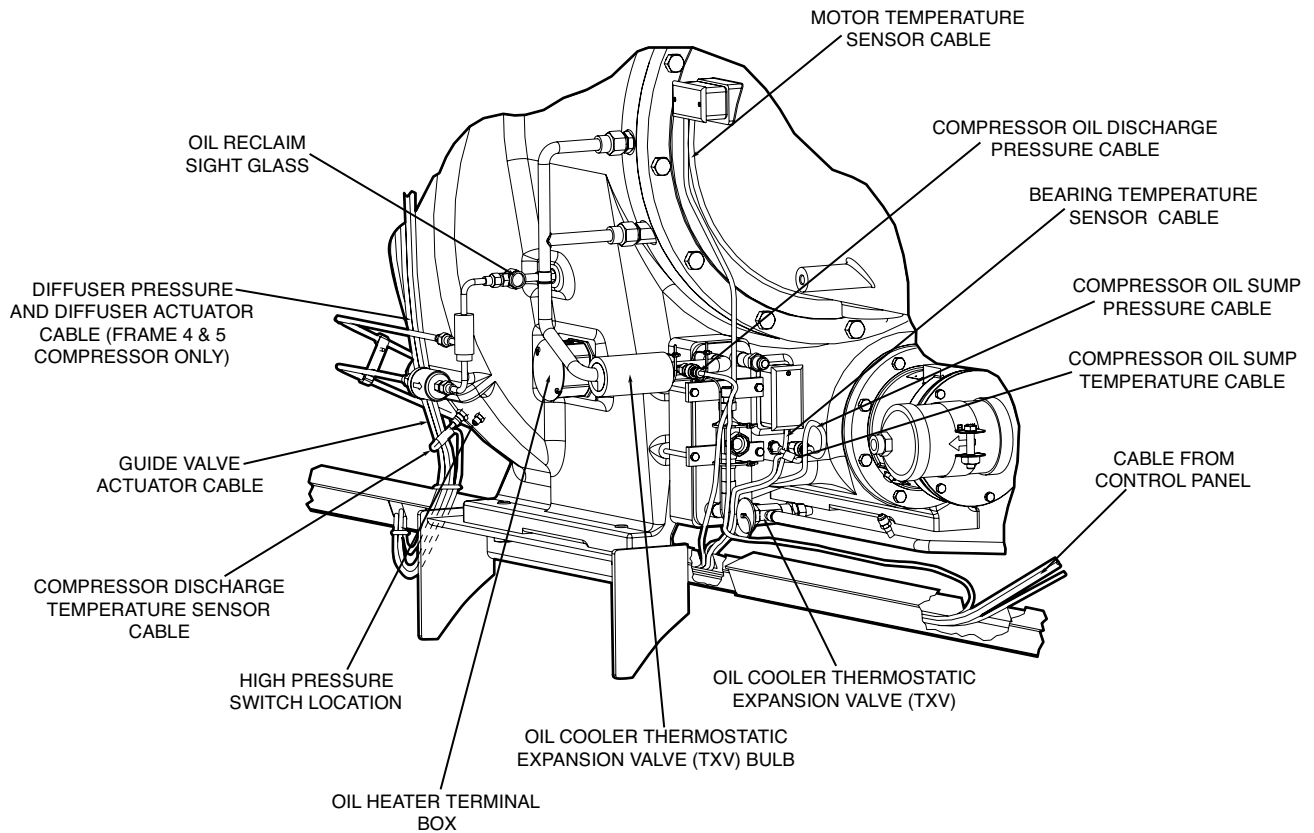

Fig. 13 — 19XRV Compressor Controls and Sensor Locations (Reference Only)

START-UP/SHUTDOWN/ RECYCLE SEQUENCE

Local Start/Stop Control

Local start-up (or manual start-up) is initiated by pressing the gray Start/Stop icon on the HMI interface. See Fig. 14. Note the display may change based on product type and options selected.

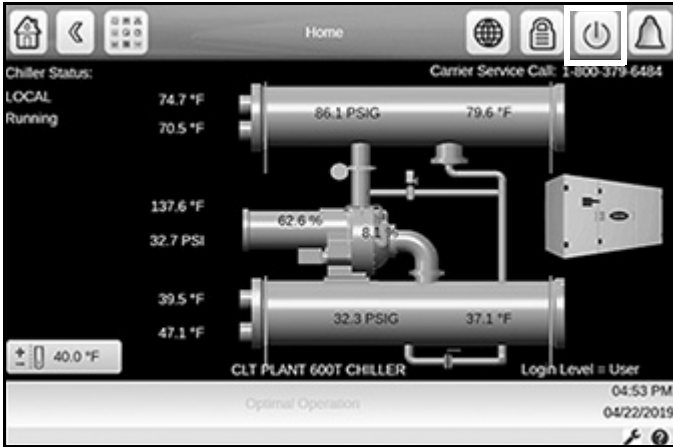

Fig. 14 — Chiller Start/Stop Icon

This initiates the PIC 6 starting sequence by displaying the list of operating modes. Press Local On to initiate start-up. See Fig. 15.

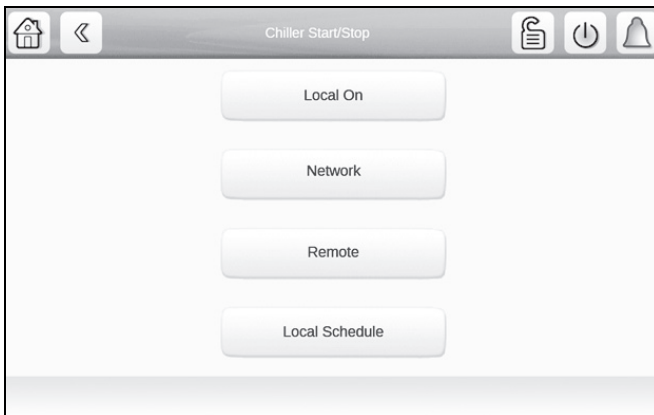



Fig. 15 — Local On

NOTE: Prior to start-up, the start-to-start timer and the stop-to-start timer must have elapsed and all alarms must be cleared (see Troubleshooting Guide section on page 51).

When start-up is initiated, the status screen displays start-up progress and the Start/Stop icon  blinks green. Once local start-up begins, the PIC 6 control system performs a series of pre-start tests to verify that all pre-start alerts and safeties are within acceptable limits. Table 2 shows appropriate Prestart Alerts/Alarms conditions. If a test is not successful, the start-up is delayed or aborted. If the tests are successful, the start-up will be in progress and the COMPRESSOR RUN STATUS shall be “Startup.” The control shall then energize the chilled water/brine pump relay.

Five seconds later, the condenser pump relay energizes. Thirty seconds later the PIC 6 control system monitors the chilled water and condenser water flow devices and waits until the *WATER FLOW VERIFY TIME* (operator-configured, default 5 minutes) expires to confirm flow. After flow is verified, the chilled water temperature is compared to *CONTROL POINT* plus $1/2$ *CHILLED WATER DEADBAND*. If the temperature is less than or equal to this value, the PIC 6 control system turns off the condenser pump relay and goes into a Recycle mode.

If the water/brine temperature is high enough, the start-up sequence continues and checks the guide vane position. If the guide vanes are more than 4% open, the start-up waits until the PIC 6 control system closes the vanes. If the vanes are closed and the oil pump pressure is less than 6 psi (41.4 kPa), the oil pump relay energizes. The PIC 6 control system then waits until the oil pressure (*OIL PRESS VERIFY TIME*, operator-configured, default of 40 seconds) reaches 18 psi (124 kPa) which indicates satisfactorily oil pump pressure to continue start-up. After oil pressure is verified, the PIC control system waits 40 seconds, and the compressor start relay energizes to start the compressor. Compressor ontime and service ontime timers start, and the compressor *STARTS IN 12 HOURS* counter and the number of starts over a 12-hour period counter advance by one.

Failure to verify any of the requirements up to this point will result in the PIC 6 control system aborting the start and displaying the applicable pre-start alert alarm state number near the bottom of the home screen on the HMI panel. A prestart failure does not advance the *STARTS IN 12 HOURS* counter. Any failure after the start command relay has energized results in a safety shutdown, advances the starts in 12 hours counter by one, and displays the applicable shutdown status on the display.

For normal start-up the minimum time to complete the entire prestart sequence is approximately 185 seconds. See Fig. 16 for normal start-up timing sequence. See Table 2 for a list of prestart checks.

Table 2 — Prestart Checks

PRESTART CHECK CONDITION*	STATE NUMBER†
STARTS IN 12 HOURS \geq 8 (not counting recycle restarts or auto restarts after power failure)	Alert – 100
OIL SUMP TEMP \leq 140°F (60°C) and OIL SUMP TEMP \leq EVAP_SAT + 50°F (27.8°C)	Alert – 101
COND PRESSURE \geq COND PRESS OVERRIDE – 20 psi	Alert – 102
#RECYCLE RESTARTS LAST 4 HOURS > 5	Alert – 103
COMP BEARING TEMPS \geq COMP BEARING ALERT – 10°F (5.6°C)	Alarm – 230
COMP MOTOR WINDING TEMP \geq MOTOR TEMP OVERRIDE – 10°F (5.6°C)	Alarm – 231
COMP DISCHARGE TEMPERATURE \geq COMP DISCHARGE ALERT – 10°F (5.6°C)	Alarm – 232
EVAP REFRIG LIQUID TEMP OR EVAP_SAT < EVAP REFRIG TRIPPOINT + EVAP OVERRIDE DELTA T	Alarm – 233
AVERAGE LINE VOLTAGE \leq UNDERVOLTAGE THRESHOLD	Alarm – 234
AVERAGE LINE VOLTAGE \geq OVERVOLTAGE THRESHOLD	Alarm – 235
CHECK FOR GUIDE VANE CALIBRATION	Alarm – 236

* If Prestart Check Condition is True, then resulting State is as indicated in the State Number column.
† See the Controls Operation and Troubleshooting guide for alarm and alert codes.
** Refrig trip point = 33°F (0.6°C) (water) and configurable for brine application.

Lubrication Control

As part of the pre-start checks executed by the controls, the oil sump temperature is compared to the evaporator saturated refrigerant temperature. If the oil temperature is less than 140°F (60°C) and less than evaporator saturated refrigerant temperature plus 50°F (27.8°C), the start-up will be delayed until either of these conditions is no longer true. Once this temperature is confirmed, the start-up continues.

The oil heater relay is energized whenever the chiller compressor is off and the oil sump temperature is less than 140°F (60°C) or the oil sump temperature is less than the evaporator saturated refrigerant temperature plus 53°F (29.4°C). The oil heater is turned off when either of the following conditions is true:

- Oil sump temperature is more than 152°F (66.7°C)
- Oil sump temperature is more than 144°F (62.2°C) and more than the evaporator saturated refrigerant temperature plus 55°F (30.6°C)

The oil heater is always off when the compressor is running. The oil pump is also energized for 30 seconds after each 30 minutes of oil heat relay being energized in order to stir the oil for more evenly distributed heating. For 19XR6/7 the oil pump stir frequency has options.

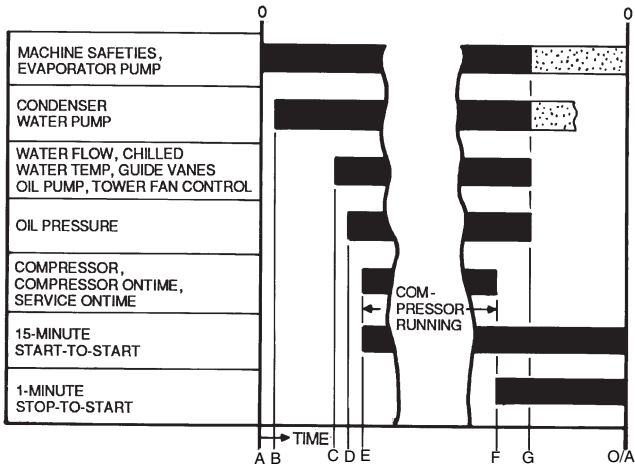

- A — START INITIATED: Pre-start checks are made; evaporator pump started.*
- B — Condenser water pump started (5 seconds after A).
- C — Water flows verified (30 seconds to 5 minutes maximum after B). Chilled water temperatures checked against control point. Guide vanes checked for closure. Oil pump started; tower fan control enabled.
- D — Oil pressure verified (15 seconds minimum, 300 seconds maximum after C).
- E — Compressor motor starts; compressor ontime and service ontime start. 15-minute inhibit timer starts (10 seconds after D), total compressor starts advances by one, and the number of starts over a 12-hour period advances by one.
- F — SHUTDOWN INITIATED — Compressor motor stops; compressor ontime and service ontime stop, and 1-minute inhibit timer starts.
- G — Oil pump and evaporator pumps de-energized (60 seconds after F). Condenser pump and tower fan control may continue to operate if condenser pressure is high. Evaporator pump may continue if in RECYCLE mode.
- O/A — Restart permitted (both inhibit timers expired: minimum of 15 minutes after E; minimum of 1 minute after F).

* Auto Restart After Power Failure Timing sequence will be faster.

Fig. 16 — Control Timing Sequence for Normal Start-Up Shutdown

The unit can be stopped locally using the HMI by pressing the green Start/Stop icon . The Unit Start/Stop screen is displayed. Press Confirm Stop (see Fig. 17).



Fig. 17 — Confirm Stop

BEFORE INITIAL START-UP

Job Data Required

- list of applicable design temperatures and pressures (product data submittal)
- chiller certified prints
- starting equipment details and wiring diagrams
- diagrams and instructions for special controls or options
- 19XR Installation Instructions

Equipment Required

- mechanic's tools (refrigeration)
- digital volt-ohmmeter (DVM)
- true RMS (root mean square) digital multimeter with clamp-on current probe or true RMS digital clamp-on ammeter for at least 480 vac
- electronic leak detector
- absolute pressure manometer or wet-bulb vacuum indicator (see Fig. 18)
- insulation tester for compressor motor rated at motor design voltage



Fig. 18 — Electronic Micron Gage

Remove Shipping Packaging

Remove any packaging material from the unit and starter.

Open Oil Circuit Valves

Check to ensure the oil filter isolation valves are open by removing the valve cap and checking the valve stem.

Tighten All Gasketed Joints

Gaskets normally relax by the time the chiller arrives at the jobsite. Tighten all gasketed joints to ensure a leak-tight chiller (does not apply to refrigerant joints covered by factory insulation). Gasketed joints (excluding O-rings) may include joints at some or all of the following:

- waterbox covers
- compressor suction elbow flanges (at compressor and at the cooler)
- compressor discharge flange
- compressor discharge line spacer (both sides) if no isolation valve
- cooler inlet line spacer (both sides) if no isolation valve
- hot gas bypass valve (both sides of valve)
- hot gas bypass flange at compressor

See Tables 3 and 4 for bolt torque requirements.

Check Chiller Tightness

Figure 19 outlines the proper sequence and procedures for leak testing.

The 19XR chillers are shipped with the refrigerant contained in the condenser shell and the oil charge in the compressor. The cooler is shipped with a small positive pressure refrigerant holding charge. Units may be ordered with the refrigerant shipped separately, along with a 15 psig (103 kPa) nitrogen-holding charge in each vessel.

To determine if there are any leaks, the chiller should be charged with refrigerant. Use an electronic leak detector to check all flanges and solder joints after the chiller is pressurized. If any leaks are detected, follow the leak test procedure (page 23).

If the chiller is spring isolated, keep all springs blocked in both directions to prevent possible piping stress and damage during the transfer of refrigerant from vessel to vessel during the leak test process, or any time refrigerant is being transferred. Adjust the springs when the refrigerant is in operating condition and the water circuits are full.

Table 3 — Bolt Torque Requirements, Foot Pounds

BOLT SIZE (in.)	SAE 2, A307 GR A HEX HEAD NO MARKS LOW CARBON STEEL		SAE 5 SOCKET HEAD OR HEX WITH 3 RADIAL LINES, OR SA499 MEDIUM CARBON STEEL		SAE 8 HEX HEAD WITH 6 RADIAL LINES OR SA354 GR BD MEDIUM CARBON STEEL	
	MINIMUM	MAXIMUM	MINIMUM	MAXIMUM	MINIMUM	MAXIMUM
1/4	4	6	6	9	9	13
5/16	8	11	13	18	20	28
3/8	13	19	22	31	32	46
7/16	21	30	35	50	53	75
1/2	32	45	53	75	80	115
9/16	46	65	75	110	115	165
5/8	65	95	105	150	160	225
3/4	105	150	175	250	260	370
7/8	140	200	265	380	415	590
1	210	300	410	580	625	893
1 1/8	330	475	545	780	985	1,410
1 1/4	460	660	770	1,100	1,380	1,960
1 3/8	620	885	1,020	1,460	1,840	2,630
1 1/2	740	1060	1,220	1,750	2,200	3,150
1 5/8	1010	1450	1,670	2,390	3,020	4,310
1 3/4	1320	1890	2,180	3,110	3,930	5,610
1 7/8	1630	2340	2,930	4,190	5,280	7,550
2	1900	2720	3,150	4,500	5,670	8,100
2 1/4	2180	3120	4,550	6,500	8,200	11,710
2 1/2	3070	4380	5,000	7,140	11,350	16,210
2 3/4	5120	7320	8,460	12,090	15,710	22,440
3	6620	9460	11,040	15,770	19,900	28,440

Table 4 — Bolt Torque Requirements, Foot Pounds (Metric Bolts)

BOLT SIZE (METRIC)	CLASS 8.8		CLASS 10.9	
	MINIMUM	MAXIMUM	MINIMUM	MAXIMUM
M4	1.75	2.5	2.5	3.5
M6	6	9	8	12
M8	14	20	20	30
M10	28	40	40	57
M12	48	70	70	100
M16	118	170	170	240
M20	230	330	330	470
M24	400	570	570	810
M27	580	830	820	1175

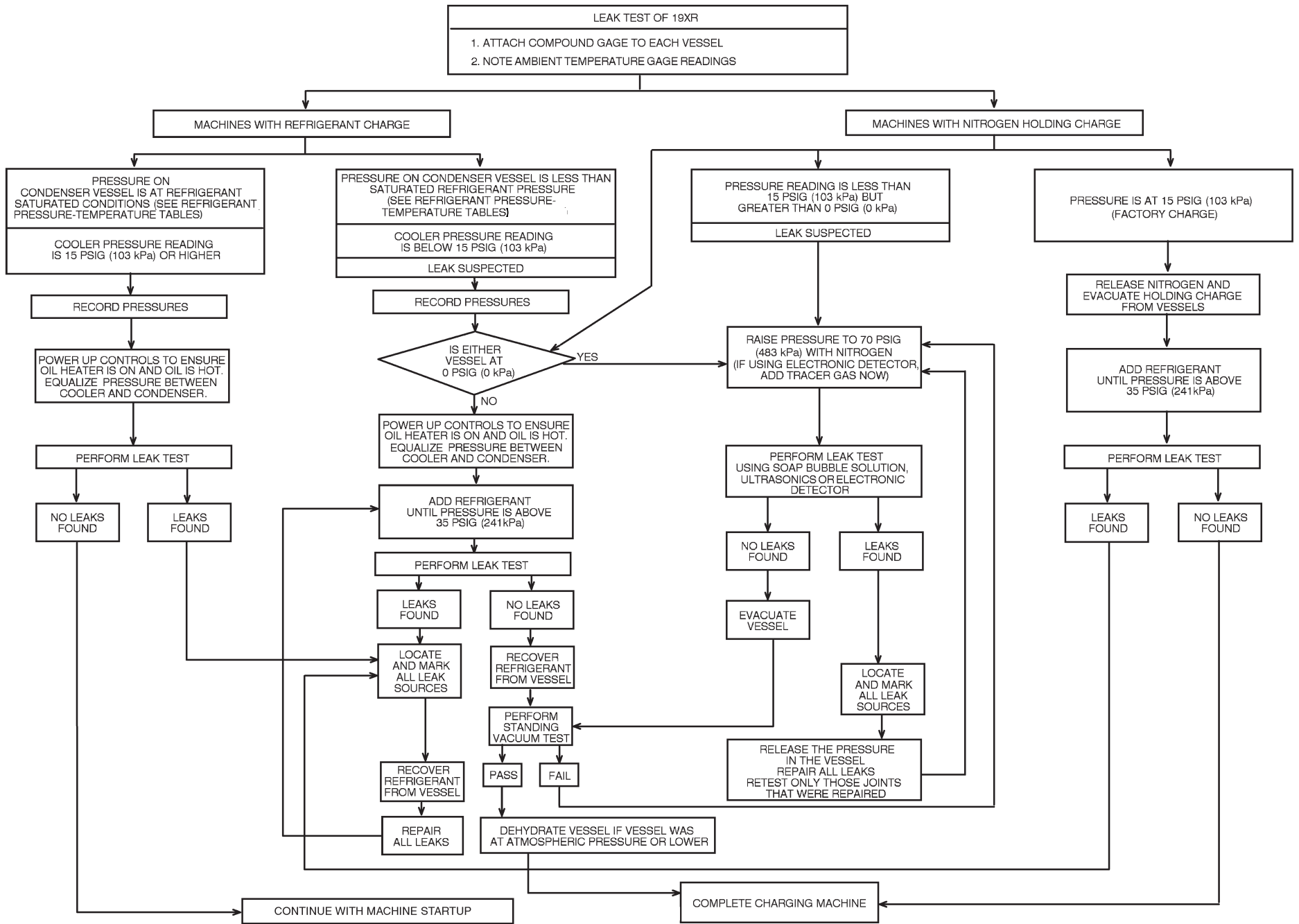

Fig. 19 — 19XR Leak Test Procedures

Refrigerant Tracer

Carrier recommends the use of an environmentally acceptable refrigerant tracer for leak testing with an electronic detector.

Ultrasonic leak detectors can also be used if the chiller is under pressure.

WARNING

Do not use air or oxygen as a means of pressurizing the chiller. Mixtures of HFC-134a and air can undergo combustion, resulting in equipment damage and possible personal injury.

Leak Test Chiller

Due to regulations regarding refrigerant emissions and the difficulties associated with separating contaminants from the refrigerant, Carrier recommends the following leak test procedure. Refer to Tables 5 and 6 for refrigerant pressure/temperature values.

1. If the pressure readings are normal for the chiller condition:
 - a. Evacuate the holding charge from the vessels, if present.
 - b. Raise the chiller pressure, if necessary, by adding refrigerant until pressure is at the equivalent saturated pressure for the surrounding temperature. Follow pumpout procedures in the Transfer Refrigerant from Pumpout Storage Tank to Chiller section, Steps 1a-e, page 42.

CAUTION

Never charge liquid refrigerant into the chiller if the pressure in the chiller is less than 35 psig (241 kPa) for HFC-134a or less than 39 psig (268 kPa) for R-513A. Charge as a gas only, with the cooler and condenser pumps running, until this pressure is reached, using PUMPDOWN/LOCK-OUT (located in the Maintenance menu) and TERMINATE LOCKOUT mode on PIC 6 control interface. Flashing of liquid refrigerant at low pressures can cause tube freeze-up and considerable damage.

- c. Leak test chiller as outlined in Steps 3 to 9.
2. If the pressure readings are abnormal for the chiller condition:
 - a. Prepare to leak test chillers shipped with refrigerant (Step 2h).
 - b. Check for large leaks by connecting a nitrogen bottle and raising the pressure to 30 psig (207 kPa). Soap test all joints. If the test pressure holds for 30 minutes, prepare the test for small leaks (Steps 2g and 2h).
 - c. Plainly mark any leaks that are found.
 - d. Release the pressure in the system.
 - e. Repair all leaks.
 - f. Retest the joints that were repaired.
 - g. After successfully completing the test for large leaks, remove as much nitrogen, air, and moisture as possible, given the fact that small leaks may be present in the system. This can be accomplished by following the dehydration procedure outlined in the Chiller Dehydration section, page 25.

- h. Slowly raise the system pressure to a maximum of 160 psig (1103 kPa) but no less than 35 psig (241 kPa) for HFC-134a by adding refrigerant (below 35 psig refrigerant must be added as a gas). Proceed with the test for small leaks (Steps 3 to 9).
3. Check the chiller carefully with an electronic leak detector or soap bubble solution.
4. Leak Determination — If an electronic leak detector indicates a leak, use a soap bubble solution, if possible, to confirm. Total all leak rates for the entire chiller. Leakage at rates greater than 0.1% of the total charge per year must be repaired. Note the total chiller leak rate on the start-up report.
5. If no leak is found during the initial start-up procedures, complete the transfer of refrigerant gas from the storage tank to the chiller. Retest for leaks.
6. If no leak is found after a retest:
 - a. Transfer the refrigerant to the storage tank and perform a standing vacuum test as outlined in the Standing Vacuum Test section, below.
 - b. If the chiller fails the standing vacuum test, check for large leaks (Step 2b).
 - c. If the chiller passes the standing vacuum test, dehydrate the chiller. Follow the procedure in the Chiller Dehydration section, page 25. Charge the chiller with refrigerant.
7. If a leak is found after a retest, pump the refrigerant back into the storage tank or, if isolation valves are present, pump the refrigerant into the non-leaking vessel. See the Transfer Refrigerant from Pumpout Storage Tank to Chiller section on page 42.
8. Transfer the refrigerant until the chiller pressure is at 18 in. Hg (40 kPa absolute).
9. Repair the leak and repeat the procedure, beginning from Step 2h, to ensure a leak-tight repair. (If the chiller is opened to the atmosphere for an extended period, evacuate it before repeating the leak test.)

Standing Vacuum Test

When performing the standing vacuum test or chiller dehydration, use a manometer or a digital vacuum gage. Dial gages cannot indicate the small amount of acceptable leakage during a short period of time.

1. Attach an absolute pressure manometer or digital vacuum gage to the chiller.
2. Evacuate the vessel to at least 18 in. Hg vac (41 kPa [abs]), using a vacuum pump or the pumpout unit.
3. Valve off the pump to hold the vacuum and record the manometer or indicator reading.
4. Check the leakage rate.
 - a. If the leakage rate is less than 0.05 in. Hg (0.17 kPa) in 24 hours, the chiller is sufficiently tight.
 - b. If the leakage rate exceeds 0.05 in. Hg (0.17 kPa) in 24 hours, re-pressurize the vessel and test for leaks if refrigerant is available. If not, use nitrogen and a refrigerant tracer. Raise the vessel pressure in increments until the leak is detected. If refrigerant is used, the maximum gas pressure is approximately 70 psig (483 kPa) for HFC-134a at normal ambient temperature. If nitrogen is used, limit the leak test pressure to 160 psig (1103 kPa) maximum.
5. Repair the leak, retest, and proceed with dehydration.

Table 5 — Pressure — Temperature (F)

TEMPERATURE (F)	HFC-134a PRESSURE (PSIG)	R-513A PRESSURE (PSIG)
0	6.50	9.22
2	7.52	10.32
4	8.60	11.45
6	9.66	12.62
8	10.79	13.84
10	11.96	15.09
12	13.17	16.39
14	14.42	17.73
16	15.72	19.11
18	17.06	20.54
20	18.45	22.02
22	19.88	23.54
24	21.37	25.11
26	22.90	26.73
28	24.48	28.40
30	26.11	30.12
32	27.80	31.89
34	29.53	33.71
36	31.32	35.59
38	33.17	37.52
40	35.08	39.51
42	37.04	41.56
44	39.06	43.66
46	41.14	45.83
48	43.28	48.05
50	45.48	50.34
52	47.74	52.68
54	50.07	55.09
56	52.47	57.57
58	54.93	60.11
60	57.46	62.72
62	60.06	65.40
64	62.73	68.14
66	65.47	70.96
68	68.29	73.84
70	71.18	76.80
72	74.14	79.83
74	77.18	82.94
76	80.30	86.13
78	83.49	89.39
80	86.17	92.73
82	90.13	96.14
84	93.57	99.64
86	97.09	103.23
88	100.70	106.89
90	104.40	110.64
92	108.18	114.48
94	112.06	118.40
96	116.02	122.41
98	120.08	126.51
100	124.23	130.71
102	128.47	134.99
104	132.81	139.37
106	137.25	143.84
108	141.79	148.41
110	146.43	153.08
112	151.17	157.85
114	156.01	162.72
116	160.96	167.69
118	166.01	172.76
120	171.17	177.94
122	176.45	183.23
124	181.83	188.62
126	187.32	194.12
128	192.93	199.74
130	198.66	205.47
132	204.50	211.31
134	210.47	217.26
136	216.55	223.34
138	222.76	229.54
140	229.09	235.85

Table 6 — Pressure — Temperature (C)

TEMPERATURE (C)	HFC-134a PRESSURE (kPa)	R-513A PRESSURE (kPa)
-17.8	44.8	63.6
-16.7	51.9	71.1
-15.6	59.3	79.0
-14.4	66.6	87.0
-13.3	74.4	95.4
-12.2	82.5	104.1
-11.1	90.8	113.0
-10.0	99.4	122.2
-8.9	108.0	131.8
-7.8	118.0	141.6
-6.7	127.0	151.8
-5.6	137.0	162.3
-4.4	147.0	173.1
-3.3	158.0	184.3
-2.2	169.0	195.8
-1.1	180.0	207.6
0.0	192.0	219.9
1.1	204.0	232.4
2.2	216.0	245.4
3.3	229.0	258.7
4.4	242.0	272.4
5.6	255.0	286.5
6.7	269.0	301.0
7.8	284.0	316.0
8.9	298.0	331.3
10.0	314.0	347.1
11.1	329.0	363.2
12.2	345.0	379.9
13.3	362.0	396.9
14.4	379.0	414.5
15.6	396.0	432.4
16.7	414.0	450.9
17.8	433.0	469.8
18.9	451.0	489.2
20.0	471.0	509.1
21.1	491.0	529.5
22.2	511.0	550.4
23.3	532.0	571.9
24.4	554.0	593.8
25.6	576.0	616.3
26.7	598.0	639.4
27.8	621.0	662.9
28.9	645.0	687.0
30.0	669.0	711.7
31.1	694.0	737.0
32.2	720.0	762.8
33.3	746.0	789.3
34.4	773.0	816.3
35.6	800.0	844.0
36.7	828.0	872.3
37.8	857.0	901.2
38.9	886.0	930.7
40.0	916.0	960.9
41.1	946.0	991.7
42.2	978.0	1023.3
43.3	1010.0	1055.4
44.4	1042.0	1088.3
45.6	1076.0	1121.9
46.7	1110.0	1156.2
47.8	1145.0	1191.1
48.9	1180.0	1226.9
50.0	1217.0	1263.3
51.1	1254.0	1300.5
52.2	1292.0	1338.4
53.3	1330.0	1377.2
54.4	1370.0	1416.7
55.6	1410.0	1456.9
56.7	1451.0	1498.0
57.8	1493.0	1539.9
58.9	1536.0	1582.6
60.0	1580.0	1626.1

Chiller Dehydration

Dehydration is recommended if the chiller has been open for a considerable period of time, if the chiller is known to contain moisture, or if there has been a complete loss of chiller holding charge or refrigerant pressure.

⚠ CAUTION

Do not start or megohm-test the compressor motor or oil pump motor, even for a rotation check, if the chiller is under dehydration vacuum. Insulation breakdown and severe damage may result if voltage is applied to the motor.

⚠ WARNING

Starters must be disconnected by an isolation switch before placing the machine under a vacuum. To be safe, isolate any starter before evacuating the chiller if you are not sure if there are live leads to the hermetic motor.

Dehydration can be done at room temperatures. Using a cold trap (Fig. 20) may substantially reduce the time required to complete the dehydration. The higher the room temperature, the faster dehydration takes place. At low room temperatures, a very deep vacuum is required to boil off any moisture. If low ambient temperatures are involved, contact a qualified service representative for the dehydration techniques required.

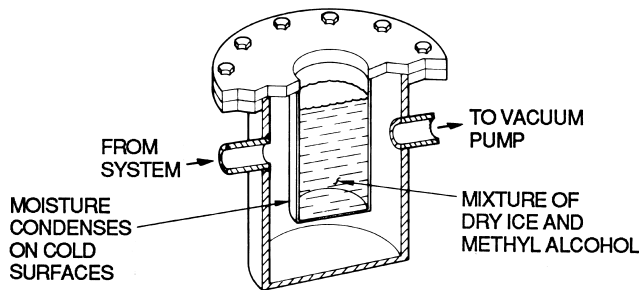

Fig. 20 — Dehydration Cold Trap

Perform dehydration as follows:

1. Connect a high capacity vacuum pump (5 cfm [0.002 m³/s] or larger is recommended) to the refrigerant charging valve (Fig. 3-5). Tubing from the pump to the chiller should be as short in length and as large in diameter as possible to provide least resistance to gas flow.
2. Use an absolute pressure manometer or a digital vacuum gage to measure the vacuum.
3. If the entire chiller is to be dehydrated, open all isolation valves (if present).
4. With the chiller ambient temperature at 60°F (15.6°C) or higher, operate the vacuum pump until the manometer reads 29.72 in. Hg (vac) (754.9 mm Hg), or a vacuum indicator reads 35°F (1.7°C). Operate the pump an additional 2 hours.
Do not apply a vacuum greater than 29.73 in. Hg (vac) (755.1 mm Hg) or go below 33°F (0.56°C) on the wet bulb vacuum indicator. At this temperature and pressure, isolated pockets of moisture can turn into ice. The slow rate of evaporation (sublimation) of ice at these low temperatures and pressures greatly increases dehydration time.
5. Valve off the vacuum pump, stop the pump, and record the instrument reading.

6. After a 2-hour wait, take another instrument reading. If the reading has not changed, dehydration is complete. If the reading indicates vacuum loss, repeat Steps 4 and 5.
7. If the reading continues to change after several attempts, perform a leak test up to the maximum 160 psig (1103 kPa) pressure. Locate and repair the leak, and repeat dehydration.
8. Once dehydration is complete, the evacuation process can continue. The final vacuum prior to charging the unit with refrigerant should in all cases be 29.9 in. Hg (500 microns, 0.07 kPa [abs]) or less.

Inspect Water Piping

Refer to piping diagrams provided in the certified drawings and the piping instructions in the 19XR Installation Instructions manual. Inspect the piping to the cooler and condenser. Be sure that the flow directions are correct and that all piping specifications have been met.

Piping systems must be properly vented with no stress on waterbox nozzles and covers. Water flows through the cooler and condenser must meet job requirements. Measure the pressure drop across the cooler and the condenser.

⚠ CAUTION

Water must be within design limits, clean, and treated to ensure proper chiller performance and to reduce the potential of tube damage due to corrosion, scaling, or erosion. Carrier assumes no responsibility for chiller damage resulting from untreated or improperly treated water.

Check Relief Valves

Be sure the relief valves have been piped to the outdoors in compliance with the latest edition of ANSI/ASHRAE Standard 15 and applicable local safety codes. Piping connections must allow for access to the valve mechanism for periodic inspection and leak testing.

The standard 19XR relief valves are set to relieve at 185 psig (1275 kPa) chiller design pressure.

Check the Optional Pumpout Compressor Water Piping

If the optional pumpout storage tank and/or pumpout system are installed, check to ensure the pumpout condenser water has been piped in. Check for field-supplied shutoff valves and controls as specified in the job data. Check for refrigerant leaks on field-installed piping.

Identify and Check Starter/VFD

Verify that the starter/VFD in submittal paperwork matches the actual starter/VFD on the jobsite. Typical design characteristic is for the stater/VFD to be able to operate in the following environment conditions. In all cases identify the starter by reviewing marking/part number on the inside/outside of the starter cabinet doors. See Table 7.

Table 7 — Starter/VFD Identification

CONDITION	SPECIFICATION
AMBIENT TEMPERATURE (OUTSIDE NEMA 1 ENCLOSURE)	32 to 104°F (0 to 40°C)
STORAGE TEMPERATURE (AMBIENT)	-40 to 149°F (-40 to 65°C)
HUMIDITY	5% to 95% (non-condensing)

Locate the appropriate wiring diagrams associated with the identified starter.

⚠ WARNING

BE AWARE that certain automatic start arrangements can engage the starter/VFD. Open the disconnect ahead of the starter/VFD in addition to shutting off the chiller or pump. Failure to do so could result in serious personal injury or death from electric shock.

⚠ WARNING

The main disconnect on the starter/VFD front panel may not de-energize all internal circuits. Open all internal and remote disconnects before servicing the starter/VFD. Failure to do so could result in serious personal injury or death from electric shock.

Mechanical Starter

1. Check all field wiring connections for tightness, clearance from moving parts, and correct connection.
2. Check the contactor(s) to ensure they move freely. Check the mechanical interlock between contactors to ensure that 1S and 2M contactors cannot be closed at the same time. Check all other electro-mechanical devices, such as relays, for free movement. If the devices do not move freely, contact the starter manufacturer for replacement components.
3. Reapply starter control power (not main chiller power) to check the electrical functions.
Ensure the starter (with relay 1CR closed) goes through a complete and proper start cycle.

Benshaw RediStart MX3 Solid-State Starter

⚠ WARNING

This equipment is at line voltage when AC power is connected. Pressing the STOP button does not remove voltage.

⚠ CAUTION

An isolation switch or circuit breaker must be open ahead of any VFD or solid-state starter when the chiller is in a vacuum. If not, damage to the machine may result.

1. Ensure all wiring connections are properly terminated to the starter.
2. Verify the ground wire to the starter is installed properly and is sufficient size.
3. Verify the motors are properly grounded to the starter.
4. Verify the proper ac input voltage is brought into the starter according to the certified drawings.
5. Confirm the field wiring does not have external power supply connected to the chiller controls/starter inputs.
6. Apply power to the starter.

VFD Starter

Use the following instructions to verify the condition of the installation:

1. Turn off, lockout, and tag the input power to the drive.
2. Wait a minimum of 5 minutes for the DC bus to discharge.
3. All wiring should be installed in conformance with the applicable local, national, and international codes (e.g., NEC/CEC).
4. Remove any debris, such as metal shavings, from the enclosure. Metal shavings on power module enclosure will void drive warranty.
5. Check that there is adequate clearance around the machine.
6. Verify that the wiring to the terminal strip and the power terminals is correct with no external power supplied to the inputs of the Carrier/starter controls.

7. Verify that all of the VFD power module circuit board connectors are fully engaged and taped in place.
8. Check that the wire size is within terminal specifications and that the wires are tightened properly.
9. Check that specified branch circuit protection is installed and correctly rated.
10. Check that the incoming power is within 10% of chiller nameplate voltage.
11. Verify that a properly sized ground wire is installed and a suitable earth ground is used. Check for and eliminate any grounds between the power leads. Verify that all ground leads are unbroken.

Verify Condition of Installation

Use the following instructions to verify condition of installation:

1. Turn off, lockout, and tag the input power to the drive.
2. Wait a minimum of 5 minutes for the DC bus to discharge.
3. All wiring should be installed in conformance with the applicable local, national, and international codes (e.g., NEC/CEC).
4. Remove any debris, such as metal shavings, from the enclosure. Metal shavings on power module enclosure will void drive warranty.
5. Check that there is adequate clearance around the machine.
6. Verify that the wiring to the terminal strip and the power terminals is correct.
7. Verify that all of the VFD power module circuit board connectors are fully engaged and taped in place.
8. Check that the wire size is within terminal specifications and that the wires are tightened properly.
9. Check that specified branch circuit protection is installed and correctly rated.
10. Check that the incoming power is within 10% of chiller nameplate voltage.
11. Verify that a properly sized ground wire is installed and a suitable earth ground is used. Check for and eliminate any grounds between the power leads. Verify that all ground leads are unbroken.

Inspect Wiring

⚠ WARNING

Do not check the voltage supply without proper equipment and precautions. Serious injury may result. Follow power company recommendations.

⚠ CAUTION

Do not apply any kind of test voltage, even for a rotation check, if the chiller is under a dehydration vacuum. Insulation breakdown and serious damage may result.

1. Examine the wiring for conformance to the job wiring diagrams and all applicable electrical codes.
2. On low-voltage compressors (600 v or less) connect a voltmeter across the power wires to the compressor starter and measure the voltage. Compare this reading to the voltage rating on the compressor and starter/VFD nameplates.
3. Compare the ampere rating on the starter/VFD nameplate to rating on the compressor nameplate.
4. The starter/VFD for a centrifugal compressor motor must contain the components and terminals required for PIC6 refrigeration control. Check the certified drawings. Note that the starter/VFD must share control of cooler and condenser liquid pumps.
5. Check the phase to phase and phase to ground line voltage to the starter/VFD, control panel (19XR6/7), power panel (19XR2-E) and optional pumpout compressor.

6. Ensure that fused disconnects or circuit breakers have been supplied for all power leads to the chiller or associated equipment.
7. Ensure all electrical equipment and controls are properly grounded in accordance with job drawings, certified drawings, and all applicable electrical codes.
8. Ensure the customer's contractor has verified proper operation of the pumps, cooling tower fans, and associated auxiliary equipment. This includes ensuring motors are properly lubricated and have proper electrical supply and proper rotation.
9. Tighten all wiring connections and inspect power panel (19XR2-E) or control panel (19XR6/7) to ensure contractor has used the knockouts to feed the wires into the enclosures and that appropriate strain relief is provided.
10. Verify all field connected wiring including option control wiring to control panel.
11. Field-installed starters only (or for VFD units only if chiller controls indicate ground fault), test the chiller compressor motor and its power lead insulation resistance with a 500-v insulation tester such as a megohmmeter. (Use a 5000-v tester for motors rated over 600 v.) Factory mounted starters do not require a megohm test.
 - a. Open the starter main disconnect switch and follow lockout/tagout rules.

⚠ CAUTION

If the motor starter is a solid-state starter or VFD, the motor leads must be disconnected from the starter before an insulation test is performed. The voltage generated from the tester can damage the starter/VFD components.

⚠ CAUTION

Do not route control wiring carrying 30 v or less within a conduit carrying 50 v or higher. Failure to observe this precaution could result in electromagnetic interference in the control wiring.

- b. With the tester connected to the motor leads, take 10-second and 60-second megohm readings as follows:
 6-Lead Motor — Tie all 6 leads together and test between the lead group and ground. Next tie the leads in pairs: 1 and 4, 2 and 5, and 3 and 6. Test between each pair while grounding the third pair.
 3-Lead Motor — Tie terminals 1, 2, and 3 together and test between the group and ground.
 - c. Divide the 60-second resistance reading by the 10-second reading. The ratio, or polarization index, must be one or higher. Both the 10 and 60-second readings must be at least 50 megohms. If the readings on a field-installed starter are unsatisfactory, repeat the test at the motor with the power leads disconnected. Satisfactory readings in this second test indicate the fault is in the power leads.
 NOTE: Unit-mounted starters do not have to be megohm tested.
12. Tighten all wiring connections to the plugs on the IOBs and PIC6 HMI panel.
13. On chillers with free-standing starters, inspect the power panel (19XR2/E) to ensure that the contractor has fed the

wires into the bottom or side of the panel. The installation of wiring into the top of the panel can cause debris to fall into the contactors. Clean and inspect the contactors if this has occurred.

14. Torque all AC power terminals to specified torque.

⚠ WARNING

Do not apply power unless a qualified Carrier technician is present. Serious personal injury may result.

Carrier Comfort Network® (CCN) and Local Equipment Network (LEN) Interface

The Communication bus wiring is supplied and installed by the electrical contractor. It consists of shielded, 3-conductor cable with drain wire. The system elements are connected to the communication bus in a daisy chain arrangement. The positive pin of each system element communication connector must be wired to the positive pins of the system element on either side of it. The negative pins must be wired to the negative pins. The signal ground pins must be wired to the signal ground pins. See installation manual.

NOTE: Conductors and drain wire must be 20 AWG (American Wire Gage) minimum stranded, tinned copper.

Individual conductors must be insulated with PVC, PVC/nylon, vinyl, Teflon¹, or polyethylene. An aluminum/polyester 100% foil shield and an outer jacket of PVC, PVC/nylon, chrome vinyl, or Teflon with a minimum operating temperature range of -4°F to 140°F (-20°C to 60°C) is required. See table below for cables that meet the requirements.

MANUFACTURER	CABLE NO.
ALPHA	2413 or 5463
AMERICAN	A22503
BELDEN	8772
COLUMBIA	02525

When connecting the communication bus to a system element, a color code system for the entire network is recommended to simplify installation and checkout. For freestanding Beshaw starters communicating via Modbus (RS-485), Carrier recommends to use Belden 3106A communication cable.

The following color code is recommended:

SIGNAL TYPE	CCN BUS CONDUCTOR INSULATION COLOR	CCN TERMINAL CONNECTION
+	Red	Red (+)
GROUND	Black	Black (G)
-	White	White (-)

Check Starter

MECHANICAL STARTER

1. Check all field wiring connections for tightness, clearance from moving parts, and correct connection.
2. Check the contactor(s) to ensure they move freely. Check all other electro-mechanical devices, such as relays, for free movement. If the devices do not move freely, contact the starter manufacturer for replacement components.
3. Reapply starter control power (not main chiller power) to check the electrical functions.

1. Teflon is a registered trademark of DuPont.

Oil Charge

The oil charge for the 19XR:

- Frame 2 compressor — 8 gal (30 L)
- Frame 3 compressor — 8 gal (30 L)
- Frame 4 compressor — 12 gal (45 L)
- Frame 4 compressor with split ring diffuser option — 12 gal (45 L)
- Frame C compressor — 14.1 gal (53.4 L)
- Frame 5 compressor — 22.5 gal (85.2 L)
- Frame E compressor — 15.3 gal (57.9 L)
- Frame 6 compressor — 28.5 gal (107.9 L)
- Frame 7 compressor — 44.4 gal (168 L)

The chiller is shipped with oil in the compressor. When the sump is full, the oil level should be no higher than the middle of the upper sight glass, and minimum level is the bottom of the lower sight glass (Fig. 3-5). If oil is added, it must meet Carrier's specification for centrifugal compressor use as described in the Oil Specification section on page 47. Charge the oil through the oil charging valve located near the bottom of the transmission housing. The oil must be pumped from the oil container through the charging valve due to higher refrigerant pressure. The pumping device must be able to lift from 0 to 200 psig (0 to 1380 kPa) or above unit pressure. Oil should only be charged or removed when the chiller is shut down.

Power Up Controls and Check Oil Heater

Ensure that an oil level is visible in the compressor and the chiller is not in a vacuum before energizing the controls. Typically for 19XR2-E a circuit breaker in the starter energizes the oil heater and the control circuit. For 19XR6/7 oil heater and control circuit is powered from the control panel.

The oil heater is energized by powering the control circuit. This should be done several hours before start-up to minimize oil-refrigerant migration. The oil heater is controlled by the PIC 6 and is powered through a contactor in the power panel (19XR2-E) control panel (19XR6/7). A separate circuit breaker powers the heater, oil pump, and the control circuit. This arrangement allows the heater to energize when the main motor circuit breaker is off for service work or extended shutdowns.

Software Configuration

⚠ WARNING

Do not operate the chiller before the control configurations have been checked and a Control Test has been satisfactorily completed. Protection by safety controls cannot be assumed until all control configurations have been confirmed. Do not assume the values in the chiller are correct. They should match the chiller labels and data sheets for the selection. If you have questions contact the Carrier Technical Service Manager or Service Engineering.

See the 19XR with PIC 6 Controls Operation and Troubleshooting manual for instructions on using the PIC 6 interface to configure the 19XR unit. As the unit is configured, all configuration settings should be written down. A log, such as the one shown on pages CL-1 to CL-11, provides a list for configuration values for future reference. When installing new software ensure to select to keep all configuration data so all data does not have to be reentered manually.

Input the Design Set Points

To access the set point screen, press the Main Menu icon on the home screen. See Fig. 21.



Fig. 21 — Main Menu Icon

The Main Menu screen is displayed. Press the Set Point Table icon (Fig. 22). Note that Login level must exceed Basic to have access to this set point.

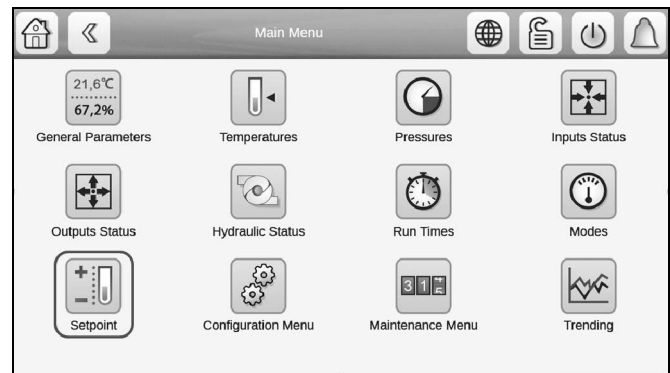

Fig. 22 — Main Menu — Set Point Table Icon

The set point screen is displayed (see Fig. 23). Set the base demand limit set point, and either the LCW set point or the ECW set point. To set a value, press the appropriate set point, enter the value, and press OK. For more information, see the 19XR with PIC 6 Controls Operation and Troubleshooting manual.

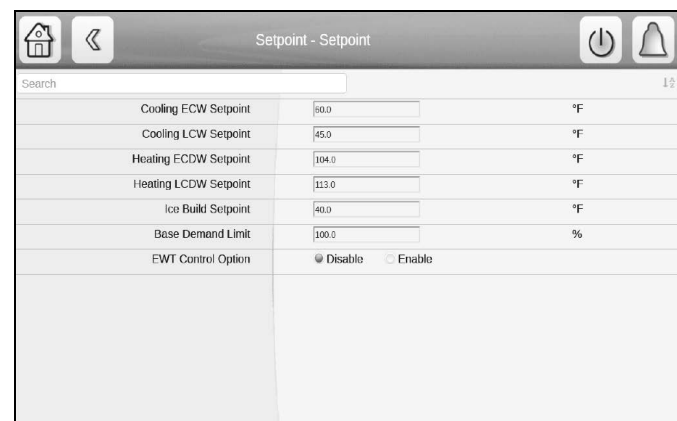

Fig. 23 — Set Point Table Screen

Input the Local Occupied Schedule

Access the schedule screen and set up the occupied time schedule according to the customer's requirements. If no schedule is available, the default is factory set for 24 hours occupied, 7 days per week including holidays. The Schedule Menu as well as the Holiday Menu can be reached through the Configuration Menu (see Appendix A on page 109 for an overview of the available menus). When the control mode is LOCAL SCHEDULE, the chiller will be automatically started if the configured local schedule is occupied; it will be shut

down by the unoccupied schedule, EMSTOP software point, STOP button on HMI screen, or remote emergency stop contact.

The Network Schedule should be configured if a CCN system is being installed. When control mode is NETWORK, the chiller can be started and stopped by the CHIL_S_S software point as written by other equipment through the network command and network schedule. The chiller can be shut down by EMSTOP software point and remote emergency stop contact.

For more information about setting time schedules, see the 19XR with PIC 6 Controls Operation and Troubleshooting manual.

Input Service Configurations

For specific values for the following configurations, refer to the chiller performance data or job-specific data sheet:

- password
- log in/logout
- input time and date
- service parameters
- equipment configuration
- automated control test

PASSWORD

The PIC 6 control system provides different levels of access: Basic access, User access, and Service access. User access provides access to the chiller controls such as Setpoint, Schedules, Time/date and Water Reset menu along with the ability to reading key input and output values pressures and temperatures. Factory user has access to factory tables - this is required in order to properly set up the chiller during commissioning. The PIC 6 default password configurations are as follows:

- Basic: No password required
- User: 1111 (factory default)
- Factory: Access Only authorized with Carrier SmartService

USER CONFIGURATION allows change of the User access password. Passwords must be from 1 to 5 digits (range from 1 to 65535).

IMPORTANT: Be sure to remember the password. Retain a copy for future reference. Without the password, access to will not be possible unless accessed by a Carrier representative.

LOGIN/LOGOUT

Press the lock icon on the home screen to enter the password. See Fig. 24.

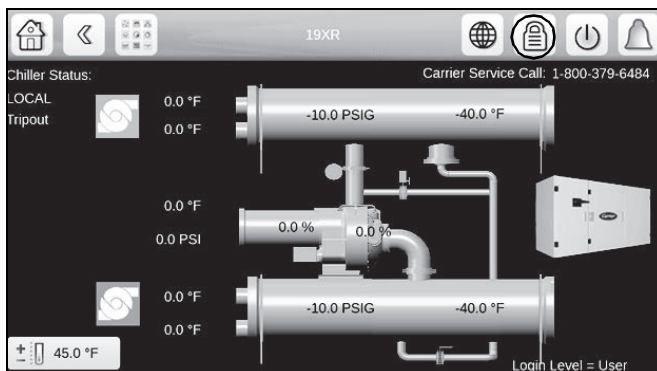

Fig. 24 — Lock Icon

For access levels higher than Basic there are two options. User Login (default password 1111) gives limited access to chiller tables. For full access a Factory Login is required. Factory Login access requires either Carrier SmartService web access or the SmartService app on a connected mobile device.

Service Login requires a code given by administrator, which will give temporary access to PIC6 Service Menu tables.

The User Login Screen is displayed. Enter the password on this screen. See Fig 25. The language and system of measurement can also be changed on this screen. For details, see the 19XR with PIC 6 Controls Operation and Troubleshooting guide.

To access the Service and Factory Login Menus select the Service Login icon.

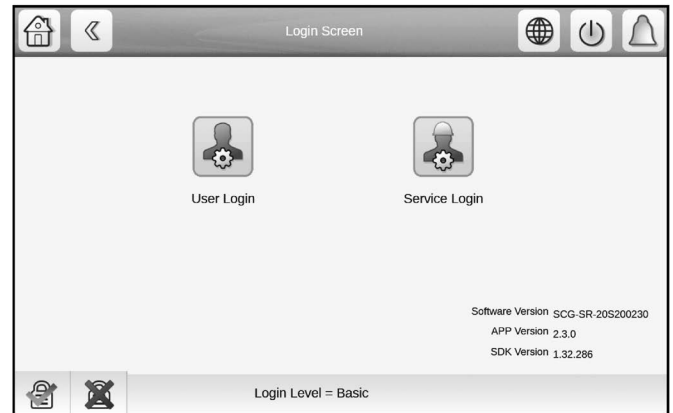

NOTE: Password is validated after user presses the log-in icon.

Fig. 25 — User Login Screen

ENGLISH/METRIC UNITS

To change PIC display from English to metric units or to change the default language, select the Globe icon; see Fig. 26. The Globe icon is next to the Lock icon (Fig. 24).



Fig. 26 — Unit Selection

INPUT TIME AND DATE

Set day and time and if applicable Holidays through **Main Menu → System Configuration → Date/time Configuration**. See the Controls Operation and Troubleshooting guide for details. Because a schedule is integral to the chiller control sequence, the chiller will not start until the time and date have been set. User password is required to access Input Time and Date menu.

MODIFY CONTROLLER IDENTIFICATION IF NECESSARY

The module address can be changed from the Configuration Menu. Change this address under CONTROL IDENTIFICATION for each chiller if there is more than one chiller at the jobsite. Write the new address on the HMI module for future reference.

CONFIGURE AND VERIFY FACTORY PARAMETER TABLES

(Service Password Required)

Access the Factory Parameters table through **Main Menu → Configuration Menu** to modify or view the job site parameters.

The applicable configuration tables are dependent upon the starter/VFD type and manufacturer. For all factory unit-mounted equipment all starter configurations should be completed at the factory, but will need to be verified during chiller commissioning.

For starters without ISM, the appropriate starter selection must be configured through **MAIN MENU → CONFIGURATION MENU → FACTORY → VFD/STARTER OPTION**.

Options are as follows:

- 0 = Starter with ISM
- 1 = Free Standing VFD with ISM [North America options: Toshiba VFD, Allen Bradley PF7000, PowerFlex 700L (unit mount)]
- 3 = Rockwell LF2 VFD (LiquiFlo2)
- 4 = Eaton VFD (LCX9000)
- 5 = Rockwell STD VFD (Allen Bradley PowerFlex 755)
- 7 = Danfoss VFD
- 8 = Benshaw Starter (Wye-delta or Solid State starters with MX3 (TM) and no ISM)

For constant speed machines verify all listed parameters in ISM Configuration. Similarly, for unit-mounted VFDs verify all parameters listed in UM VFD Configuration Tables 8-11. Verify against chiller electrical nameplates.

For units that are doing native communicating Modbus without a UPC gateway ensure that the Modbus Gateway Option in **MAIN MENU → CONFIGURATION MENU → MODBUS MASTER** is changed to 0=Native along with baud rate and Slave Device Address. Baud rate is typically 9,600 and slave address is 1.

Liquid bypass option allows bypass of the economizer. When Enabled and available the 19XR with frame C bypass valve will modulate based on lift and % Amps to allow for high cooling capacity at low load.

Dynamic Demand Limit is a control feature which will demand limit the chiller to prevent refrigerant stack-up due to high refrigerant flow at low lift. It is required to set LCW at Selection Point and LCDW at Selection Point as well as Enable the Dynamic Demand Limit function to make this feature active.

**Table 8 — Typical Job Site Parameters
(Main Menu → Configuration Menu → CONF_OPT → Option Configuration [for all Starter/VFD options])**

PARAMETER	TABLE
AUTO RESTART OPTION	CONF_OPT — Disable/Enable
SWIFT RESTART OPTION	CONF_OPT — Disable/Enable
COMMON SENSOR OPTION	CONF_OPT — Disable/Enable
EC/HG (HGBP) VALVE OPTION	CONF_OPT — 0=No HGBP valve, 1= Continuous (two contactor control - one to open, one to close with feedback of fully closed and open position), 2= on/off (1 contactor control - either on or off and no feedback), 3 = mA (control by 4-20 mA signal with feedback)
EC/HG (HGBP) VALVE SELECTION	CONF_OPT - 0 = Disable, 1=Surge (HGBP valve activates when surge prevention is high), 2= Low Load (EC valves activates based on IGV position and delta T for low load operation). EC valve is to Open when IGV position is less than the configured ECV Open IGV1 Position and (cooling mode) the water Delta T (ECW-LCW) is less than or equal to ECV On DT for Low Load minus ECV Low Load DB. EC valve is to Close when IGV position is greater than the ECV Close IGV1 Position and (cooling mode) water Delta T is greater than the ECV Off DT for Low Load plus ECV Low Load DB. 3=Combined (EC valves controlled by both surge and low load algorithms)
HPR VLV OPTION	Disable/Enable. When enabled, values for HPR VLV Delta Pos 0% (4 mA), HPR VLV Delta Pos 100% (20 mA), HPR VLV Min Output (minimum output %), and HPR VLV Deadband can be set. Typically HPR VLV Deadband must be set at 0.5 psig for normal operation.
TOWER FAN HIGH SETPOINT	Default 75°F
REFRIG LEAKAGE OPTION	Disable/Enable
OIL COOLER EXV OPTION	Disable/Enable
CUSTOMER ALERT OPTION	Disable/Enable
ICE BUILD OPTION	Disable/Enable
VAPOR SOURCE SV OPTION	Disable/Enable
VAPOR SOURCE SV DELAY	Default 5 min
EVAP LIQUID TEMP OPT	Disable/Enable
EVAP APP CAL SELECTION	0 = Saturation Temp, 1 = Refrigerant Temperature

*With variable flow systems this point may be configured to the lower end of the range.

**Table 9 — Typical Job Site Parameters
(Main Menu → Configuration Menu → Option2 → Option Configuration [for all Starter/VFD options])**

PARAMETER	TABLE
IOB3 OPTION	No/Yes (always "Yes" for North America 19XRs)
IOB4 OPTION	No/Yes (select if optional fourth IOB board is present)
FREE COOLING	No/Yes
WATER PRESSURE OPTION	0=No, 1=WTR Flow PD TRD (dedicated water pressure transducers), 2=WTR Flow PD TRM (differential water flow pressure transmitter - 4-20 mA)
WATER FLOW MEASUREMENT	0=No, 1=WTR Flow MTR (4-20 mA water flow sensors), 2=WTR Flow PD (based on water pressure drop measurement)
WATER FLOW DETERMINATION	0=Saturated Temp, 1=Flow Switch, 2=Water Flow PD
MARINE OPTION	Disable/Enable

**Table 10 — Typical Job Site Parameters
(Main Menu→Configuration Menu→General [for all Starter/VFD options])**

PARAMETER	TABLE
DEMAND LIMIT TYPE	GENCONF - 0=Base Demand, 1=4-20mA
PULLDOWN RAMP TYPE	GENCONF - 0=Temperature, 1= Load
DEMAND LIMIT SOURCE	GENCONF - 0=Amperes, 1= kW

NOTE: Other parameters in this menu are normally left at the default settings; they may be changed as required.

**Table 11 — Typical Job Site Parameters (19XRC)
(Main Menu→Configuration Menu→Low Load)**

PARAMETER	TABLE
ECO LBP VLV OPTION	LQBP - Disable/Enable
ECO LBP BYPASS VLV LIMIT	LQBP - 100%
DSH DEADBAND FOR LBP	LQBP - 2°F
ECO LBP VLV EVAP APPROACH	LQBP - 5°F
DYNAMIC DEMAND LIMIT (DDL)	Disable/Enable
IGNORE DDL TIME	30 min (default)
LCW AT SELECTION POINT	45°F (default)
LCDW AT SELECTION POINT	95°F (default)
100% LIFT DEMAND LIMIT	100% (default)
MIDDLE LIFT PERCENT	60% (default)
MIDDLE LIFT DEMAND LIMIT	80 (default)
20% LIFT DEMAND LIMIT	45% (default)

Field Set Up and Verification

IMPORTANT: Some parameters are specific to the chiller configuration and will need to be verified prior to operation. All command functions must be initiated from the HMI.

Use the HMI touch screen to confirm that the configuration values match the chiller parameter labels and Chiller Builder design data sheet. See typical jobsite parameters in Tables 8 and 10. Different service tables will need to be checked based on starter selection.

LABEL LOCATIONS

Verify the following labels have been installed properly and match the chiller requisition:

- Surge Parameters — Located inside the chiller control panel.
- Chiller identification nameplates — Located on the right side of the control panel. A unit-mounted VFD alternate information nameplate will have two additional labels. (See Fig. 27.)
 - External Machine Electrical Nameplate — located right side of the VFD (See Fig. 28).
 - Internal Machine Electrical Nameplate — located on the inside of the left VFD enclosure door.

STARTER/DRIVE PROTECTION AND OTHER INCOMING WIRING

1. Verify that the branch disconnects or other local disconnects are open and properly tagged out.
2. Verify that the branch circuit protection and AC input wiring to the starter are in accordance with NEC/CEC (National Electrical Code/California Energy Commission) and all other local codes.
3. Verify that the fuses are per the field wiring diagram.

4. Verify that the incoming source does not exceed the SCCR (short circuit current rating) of the equipment marking.
5. Verify the power lugs in the starter/VFD and branch protection are properly secured. Inspect the ground cable and ensure it is properly connected at the branch and to the ground lug in the starter.
6. Verify the conduit for the power wiring is securely connected to the starter flanged cover and runs continuously to the branch protection.
7. Ensure the control and signal wires connected to the chiller controller or the starter/VFD are in separate conduits.

FINE TUNING VPF (VARIABLE PRIMARY FLOW) SURGE PREVENTION

Figures 29-32 show how the parameters defined below will affect the configured surge line. The menu can be found under **MAIN MENU → CONFIGURATION MENU → SURGE CORRECTION CONFIG.**

NOTE: Before tuning surge prevention, check for VFD speed limitation or capacity overrides. If the source of low capacity is found in one of these places, do not proceed with an attempt to tune the Surge Prevention configurations.

If capacity is not reached
and

1. ACTUAL GUIDE VANE POSITION < GUIDE VANE TRAVEL RANGE
and
2. SURGE PREVENTION ACTIVE = YES (can be identified in **MAIN MENU → MAINTENANCE MENU → SURGE CORRECTION**)
and
3. PERCENT LINE CURRENT < 100%
then the surge line is probably too conservative.

Carrier A United Technologies Company		
REFRIGERATION MACHINE		
MODEL NUMBER	SERIAL NO.	
MACHINE		
COMP'R		
COOLER		
CONDENSER		
ECON		
STOR TANK		
RATED TONS		
RATED -KW		
REFRIGERANT	LBS.	KGS.
R-	CHARGED	
COMPRESSOR MOTOR DATA		
VOLTS/PHASE/HERTZ	AC	
RL AMPS	LR AMPS Y-	
OLT AMPS	LR AMPS D-	
MAX FUSE/CIRCUIT BKR		
MIN. CIRCUIT AMPACITY		
TEST PRESSURE	PSI	KPA
DESIGN PRESSURE	PSI	KPA
CLR. WATER PRESSURE	PSI	KPA
COND. WATER PRESSURE	PSI	KPA
CARRIER CHARLOTTE 9701 OLD STATESVILLE ROAD CHARLOTTE, NORTH CAROLINA 28269 MADE IN USA PRODUCTION YEAR: 20xx		
SAFETY CODE CERTIFICATION THIS UNIT IS DESIGNED, CONSTRUCTED, AND TESTED IN CONFORMANCE WITH ANSI/ASHRAE 15 (LATEST REVISION), SAFETY CODE FOR MECHANICAL REFRIGERATION. THE COMPRESSOR MOTOR CONTROLLER AND OVERLOAD PROTECTION MUST BE IN ACCORDANCE WITH CARRIER SPECIFICATION Z-415.		

TYPICAL CHILLER ID NAMEPLATE — CONSTANT SPEED STARTER OR FREESTANDING VFD

Fig. 27 — Machine Identification Nameplate

Carrier A United Technologies Company	
MODEL NUMBER	
SERIAL NUMBER	
MACHINE NAMEPLATE SUPPLY DATA	
VOLTS/PHASE/HERTZ	
LOCKED ROTOR AMPS	
OVERLOAD TRIP AMPS	
MAX FUSE/CIRCUIT BREAKER SIZE	
MIN SUPPLY CIRCUIT AMPACITY	
MACHINE ELECTRICAL DATA	
MOTOR NAMEPLATE VOLTAGE	
COMPRESSOR 100% SPEED	
RATED LINE VOLTAGE	
RATED LINE AMPS	
RATED LINE KILOWATTS	
MOTOR RATED LOAD KW	
MOTOR RATED LOAD AMPS	
MOTOR NAMEPLATE AMPS	
MOTOR NAMEPLATE RPM	
MOTOR NAMEPLATE KW	
INVERTER PWM FREQUENCY	
SAFETY CODE CERTIFICATION THIS UNIT IS DESIGNED, CONSTRUCTED, AND TESTED IN CONFORMANCE WITH ANSI/ASHRAE 15 (LATEST REVISION), SAFETY CODE FOR MECHANICAL REFRIGERATION. THE COMPRESSOR MOTOR CONTROLLER AND OVERLOAD PROTECTION MUST BE IN ACCORDANCE WITH CARRIER SPECIFICATION Z-415.	

INTERNAL

Carrier A United Technologies Company	
MODEL NUMBER	
SERIAL NUMBER	
MACHINE ELECTRICAL DATA	
LINE SIDE	
VOLTAGE	
PHASE	
HZ	-3-
CHILLER FL AMPS	
MAX FUSE/CIRCUIT BREAKER	
MIN. CKT AMPACITY	
LOAD SIDE	
VOLTAGE	
PHASE	-3-
HZ	
MOTOR FLA	
MOTOR LRA	
SAFETY CODE CERTIFICATION THIS UNIT IS DESIGNED, CONSTRUCTED, AND TESTED IN CONFORMANCE WITH ANSI/ASHRAE 15 (LATEST REVISION), SAFETY CODE FOR MECHANICAL REFRIGERATION. THE COMPRESSOR MOTOR CONTROLLER AND OVERLOAD PROTECTION MUST BE IN ACCORDANCE WITH CARRIER SPECIFICATION Z-415.	

EXTERNAL

Fig. 28 — Machine Electrical Data Nameplate

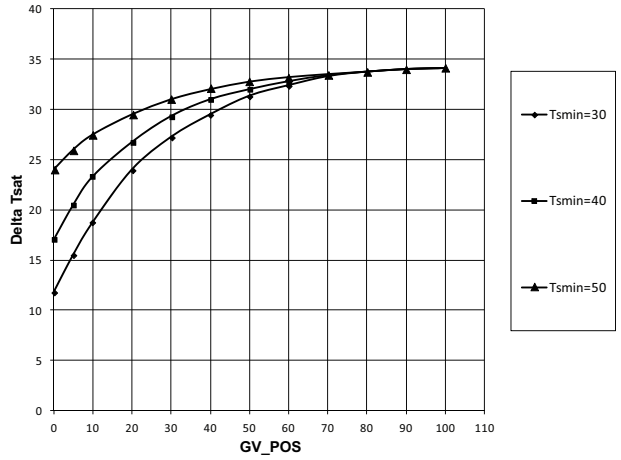

Fig. 29 — Effect of SURGE DELTA TSMIN on Surge Prevention

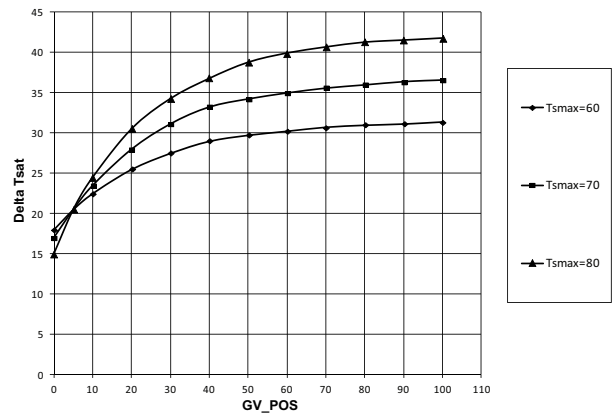

Fig. 30 — Effect of SURGE DELTA TSMAX on Surge Prevention

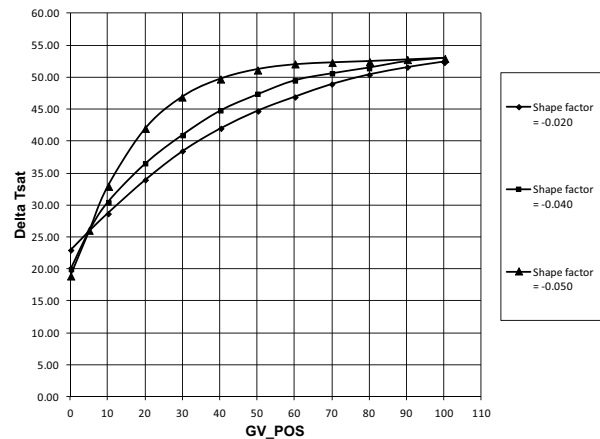

Fig. 31 — Effect of SURGE LINE SHAPE FACTOR on Surge Prevention

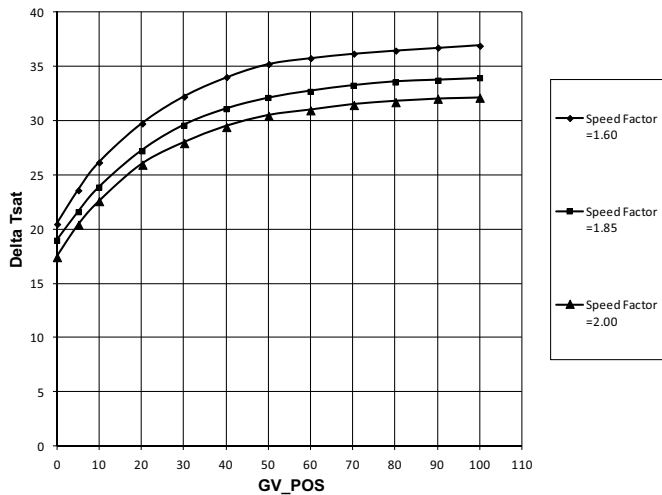

Fig. 32 — Effect of SURGE LINE SPEED FACTOR on Surge Prevention

Note the following parameters from HMI when maximum ACTUAL LINE CURRENT is achieved:

- EVAPORATOR REFRIGERANT TEMP
- EVAPORATOR PRESSURE
- CONDENSER REFRIG TEMP
- CONDENSER PRESSURE
- ACTUAL GUIDE VANE POSITION
- ACTUAL LINE CURRENT

The ACTIVE DELTA TSAT and the CALC REF DELTA TSAT can be monitored on the *MAINTENANCE MENU* → *SURGE CORRECTION* screen. When ACTUAL DELTA TSAT exceeds CALC REF DELTA TSAT + ENVELOPE LINE OFFSET surge prevention will occur.

If ACTUAL GUIDE VANE POSITION is less than 30%, then increase SURGE DELTA TSMIN in steps of 2°F (1.2°C) until one of the three conditions listed above no longer applies. Do not change SURGE DELTA TSMAX.

If ACTUAL GUIDE VANE POSITION is greater than 60%, then increase SURGE DELTA TSMAX in steps of 2°F (1.2°C) until cooling capacity is reached or one of conditions listed above no longer applies. Do not change SURGE/HGBP DELTA TSMIN.

If ACTUAL GUIDE VANE POSITION is more than 30% AND less than 60%, then:

1. Increase SURGE DELTA TSMIN in steps of 2°F (1.2°C). Alternatively if Pressure Ratio Method is used for surge protection increase PR at Minimum Opening.
2. Increase SURGE DELTA TSMAX in steps of 2°F (1.2°C). Alternatively if Pressure Ratio Method is used for surge protection increase PR at Full Load Opening.
3. Repeat Steps 1 and 2 until one of the conditions listed above no longer applies.

NOTE: DELTA TSMIN should seldom need to be increased more than 10 degrees above the selection program value. Likewise, DELTA TSMAX rarely requires more than a 2°F (1.2°C) increase.

If surge is encountered then the controls surge prevention algorithm surge line is probably too optimistic or high. Note following parameters from HMI at surge:

- EVAPORATOR REFRIGERANT TEMP
- EVAPORATOR PRESSURE
- CONDENSER REFRIG TEMP
- CONDENSER PRESSURE
- ACTUAL GUIDE VANE POSITION
- AVERAGE LINE CURRENT

If ACTUAL GUIDE VANE POSITION is less than 30%, go to Step 1. If ACTUAL GUIDE VANE POSITION is greater than 60%, then go to Step 3.

1. Do not change SURGE LINE SHAPE FACTOR from the value selected by Chiller Builder (ECAT). Decrease SURGE DELTA TSMIN or PR at Minimum Opening. Monitor chiller for surge.
2. If ACTUAL GUIDE VANE POSITION is still less than 30% and Step 1 failed, increase the value of SURGE LINE SHAPE FACTOR in steps of 0.01 up to 2 times. For example, if surge is encountered when shape factor is -0.06, increase the SURGE LINE SHAPE FACTOR to -0.05. If this does not solve the problem, go to Step 5, even if ACTUAL GUIDE VANE POSITION is less than 30%.
3. Do not change SURGE LINE SHAPE FACTOR from the value selected by Chiller Builder (ECAT). Decrease SURGE DELTA TSMAX or PR at Full Load Opening. Monitor chiller for surge.
4. If ACTUAL GUIDE VANE POSITION is greater than 60% and Step 3 failed to eliminate surge, then set SURGE DELTA TSMAX or PR at Full Load Opening to below the value specified by Chiller Builder (ECAT). Increase the value of the SURGE LINE SHAPE FACTOR in steps of 0.01 up to 2 times. For example, if surge is encountered when the SURGE LINE SHAPE FACTOR is -0.06, increase the SURGE LINE SHAPE FACTOR to -0.05. If this does not solve the problem, go to Step 5, even if ACTUAL GUIDE VANE POSITION is greater than 60%.
5. If ACTUAL GUIDE VANE POSITION is greater than 30% but less than 60% or if Step 2 failed (with ACTUAL GUIDE VANE POSITION less than 30) or if Step 4 failed (with ACTUAL GUIDE VANE POSITION greater than 60), then perform this step. Do not change SURGE LINE SHAPE FACTOR from the value specified by Chiller Builder (ECAT). Reset SURGE DELTA TSMIN or PR at Minimum Opening and SURGE DELTA TSMAX, or PR at Full Load Opening to the value specified by Chiller Builder (ECAT). Decrease both SURGE DELTA TSMIN / PR at Minimum Opening and SURGE DELTA TSMAX / PR at Full Load Opening with equal steps. Monitor chiller for surge.

If the chiller is equipped with a VFD and the drive does not slow down adequately at part load, then the machine is likely operating at a point above the configured “software” surge line and the machine is in surge prevention mode. Check for a surge protection message on the HMI. If the unit is not in a surge protection state, then the ENVELOPE SPEED FACTOR may need to be increased (more aggressive surge line protection) in combination with a decrease (less negative) in the SURGE LINE SHAPE FACTOR. Units configured with Surge Line Configuration 0=PR (Pressure Ratio) can be similarly adjusted. In lieu of changing Tmax/Tsmin values, pressure ratios at Full/Minimum Load are to be adjusted to obtain the same results.

NOTE: A good starting point if adjustments are needed with a two stage compressor is a shape factor of 2.10 and a speed factor of -0.045.

MODIFY EQUIPMENT CONFIGURATION IF NECESSARY

The Configuration Menu has other tables to select, view, or modify parameters. Carrier's certified drawings have the configuration values required for the jobsite. Modify these values only if requested. Tables include Service Parameters, General Configuration, Reset Configuration, and Protocol Configuration. Modifications can include:

- Chilled water reset (**CONFIGURATION MENU** → **RESET CONFIGURATION MENU**)
- Entering chilled water control (Enable/Disable) (**MAIN MENU** → **SETPOINT**)
- 4 to 20 mA demand limit (**CONFIGURATION MENU** → **GENERAL CONFIGURATION**)
- Auto restart option (Enable/Disable) (**CONFIGURATION MENU** → **OPTION CONFIGURATION MENU**)
- Remote contact option (Enable/Disable) — active when chiller is in Remote mode

See the 19XR with PIC 6 Controls Operation and Troubleshooting guide for more details about these functions.

VFD CONTROL VERIFICATION (NON-RUNNING)

VFDs with ISM requires low voltage controls verification. The PIC software monitors VFD Target Speed (VFD_Out; J8B-1,2), VFD Speed Feedback (VFD_In; J6-1,2); it will declare abnormal condition Alarm if the VFD Target Speed and Actual VFD speed differs by greater than $\pm 10\%$. The ISM outputs a 4-20 mA target speed signal to the drive from terminal J8B-1. The speed output and the actual drive frequency need to be calibrated to match along the speed curve. This low calibration is done with the drive in "Low Voltage Test Mode" or without the power leads connected to the motor so the chiller cannot start.

Go to **MAINTENANCE MENU** → **ISM CALIBRATION** → **J8B 4-20 MA OUTPUT. ENABLE** calibration and set for 20 mA signal. Record and enter actual mA signal as received by VFD or mA meter and execute. Then go to VFD status screen and verify that the Target VFD speed is 100.0%. It will now need to be confirmed that the target VFD speed is 100% at the drive. Then the Actual VFD Speed is verified on the PIC (this is the VFD Speed Feedback of 5 or 10 vdc (depending on selection) vdc to input of the ISM is J6-1,2. If the Target and Actual VFD Speed values are different when given a 100% target speed signal and after the signal at the VFD panel is confirmed to be 60 Hz (50 Hz), then the output voltage from the drive can be calibrated to match the actual voltage being read at ISM terminals J6-1,2 (**MAINTENANCE MENU** → **ISM CALIBRATION** → **J6 0-10V INPUT**). The chiller must be shut down to enable ISM Calibration.

Upon successful calibrating the drive and the ISM setting at the 100% target speed repeat at speed settings 90%, 80% and 70%. See Table 12.

Table 12 — Calibration Settings

SIGNAL J8B (4-20 mA)	TARGET SPEED (%)	FREQ (50 Hz), Hz	FREQ (60 Hz), Hz
20.0	100	50	60
18.4	90	45	54
16.8	80	40	48
15.2	70	35	42

Procedure is complete when for all points the Target VFD % matches the Actual VFD Speed % as obtained from the PIC5 VFD Status screen matches within 5% or better.

Perform a Controls Test (Quick Test/ Quick Calibration)

Check the safety controls status by performing an automated controls test. Actuators with feedback like inlet guide vane actuator

need to be calibrated using the Quick Calibration menu prior to unit startup. Other controls tests can be done using the Quick Test Menu. The Quick Test or Quick Calibration menu can be accessed from the MAIN MENU. (The QUICK TEST screen can only be accessed when the chiller is in STOP mode.) On the QUICK TEST table screen, select a test to be performed.

The Quick Test checks all outputs and inputs for function. In order to successfully proceed with the controls test, the compressor should be off, no alarms showing, and voltage should be within $\pm 10\%$ of rating plate value. Each test asks the operator to confirm the operation is occurring and whether or not to continue. If an error occurs, the operator can try to address the problem as the test is being done or note the problem and proceed to the next test.

NOTE: If during the controls test the guide vanes do not open, verify the low pressure alarm is not active. (An active low pressure alarm causes the guide vanes to close.)

NOTE: The oil pump test will not energize the oil pump if cooler pressure is below -5 psig (-35 kPa).

When the controls test is finished, the test stops and the QUICK TEST menu displays. If a specific automated test procedure is not completed, access the particular control test to test the function when ready. For information about calibration, see the sections Checking Pressure Transducers, page 55, and High Altitude Locations, page 55.

Quick Calibration, which is also located in the Main Menu, is used to calibrate inlet guide vanes and devices with 4-20mA feedback. Calibration is mandatory for chiller function and controls will not allow the chiller to start if calibration is not completed.

Check Optional Pumpout System Controls and Compressor

Controls include an on/off switch, a 0.5-amp fuse, the compressor overloads, an internal thermostat, a compressor contactor, refrigerant low pressure cut-out, and a refrigerant high pressure cutout. The high pressure cutout is factory set to open at 185 psig (1276 kPa) and reset at 140 psig (965 kPa). The low pressure cutout is factory set to open at 7 psia (-15.7 in. HG) and close at 9 psia (-11.6 in. HG). Ensure the water-cooled condenser has been connected. Ensure oil is visible in the compressor sight glass. Add oil if necessary.

See the Pumpout and Refrigerant Transfer Procedures and Optional Pumpout System Maintenance sections, pages 39 and 50, for details on the transfer of refrigerant, oil specifications, etc.

Charge Refrigerant into Chiller

⚠ CAUTION

The transfer, addition, or removal of refrigerant in spring isolated chillers may place severe stress on and damage external piping if springs have not been blocked in both up and down directions.

⚠ CAUTION

Always operate the condenser and chilled water pumps during charging operations to prevent freeze-ups.

The standard 19XR chiller is shipped with the refrigerant already charged in the vessels. However, the 19XR chiller may be ordered with a nitrogen holding charge of 15 psig (103 kPa). Evacuate the nitrogen from the entire chiller, and charge the chiller from refrigerant cylinders.

CHILLER EQUALIZATION WITHOUT A PUMPOUT UNIT

⚠ CAUTION

When equalizing refrigerant pressure on the 19XR chiller after service work or during the initial chiller start-up, *do not use the discharge isolation valve to equalize*. A charging hose (connected between the charging valves on top of the cooler and condenser) should be used as the equalization valve. Failure to follow this procedure may damage equipment.

To equalize the pressure differential on a refrigerant isolated 19XR chiller, use the terminate lockout function PUMPDOWN/LOCKOUT (located in the Maintenance Menu). This helps to turn on pumps and advises the operator on proper procedures.

The following steps describe how to equalize refrigerant pressure in an isolated 19XR chiller without a pumpout unit.

1. Access terminate lockout function on the Maintenance Menu. (Alternatively, the Quick Test provides a means for cooler and condenser pump control.)

IMPORTANT: Turn on the chilled water and condenser water pumps to prevent freezing

2. Slowly open the refrigerant charging valves. The chiller cooler and condenser pressures will gradually equalize. This process takes approximately 15 minutes.
3. Once the pressures have equalized, the cooler isolation valve, the condenser isolation valve, and the hot gas isolation valve may now be opened. Refer to Fig. 33 and 34 for the location of the valves.

⚠ WARNING

Whenever turning the discharge isolation valve, be sure to reattach the valve locking device. This prevents the valve from opening or closing during service work or during chiller operation. Failure to follow this procedure may damage equipment and result in bodily injury.

CHILLER EQUALIZATION WITH FREE-STANDING PUMPOUT UNIT

The following steps describe how to equalize refrigerant pressure on an isolated 19XR chiller using the pumpout unit.

1. Access the terminate lockout function on the PUMPDOWN/LOCKOUT screen (located in the Maintenance Menu).

IMPORTANT: Turn on the chilled water and condenser water pumps to prevent freezing.

2. Open valve 4 on the pumpout unit and open valves 1a and 1b on the chiller cooler and condenser, Fig. 33 and 34. Slowly open valve 2 on the pumpout unit to equalize the pressure. This process takes approximately 15 minutes.

3. Once the pressures have equalized, the discharge isolation valve, cooler isolation valve, optional hot gas bypass isolation valve, and refrigerant isolation valve can be opened. Close valves 1a and 1b, and all pumpout unit valves.

⚠ WARNING

Whenever turning the discharge isolation valve, be sure to reattach the valve locking device. This prevents the valve from opening or closing during service work or during chiller operation. Failure to follow this procedure may damage equipment and result in bodily injury.

The full refrigerant charge on the 19XR chiller will vary with chiller components and design conditions, as indicated on the job data specifications. An approximate charge may be determined by adding the condenser charge to the cooler charge as listed in the Heat Exchanger Data tables in the Physical Data section that begins on page 55.

⚠ CAUTION

Always operate the condenser and chilled water pumps whenever charging, transferring, or removing refrigerant from the chiller. Always confirm that water flow is established. Failure to follow this procedure may result in equipment damage.

Use the PUMPDOWN/LOCKOUT terminate lockout function to monitor conditions and start the pumps.

If the chiller has been shipped with a holding charge, the refrigerant is added through the pumpout charging connection (Fig. 33 and 34, valve 1b). First evacuate the nitrogen holding charge from the chiller vessels. Charge the refrigerant as a gas until the system pressure exceeds 35 psig (241 kPa) for HFC-134a or 39 psig (268 kPa) for R-513A. After the chiller is beyond this pressure the refrigerant should be charged as a liquid until all the recommended refrigerant charge has been added. The charging valve (Fig. 33 and 34, valve 7) can be used to charge liquid to the cooler if the cooler isolation valve (11) is present and is closed. Do not charge liquid backwards through any of the floats to the condenser.

TRIMMING REFRIGERANT CHARGE

The 19XR chiller is shipped with the correct charge for the design duty of the chiller. Trimming the charge can best be accomplished when the design load is available. To trim the charge, check the temperature difference between the leaving chilled water temperature and cooler refrigerant temperature at full load design conditions. If necessary, add or remove refrigerant to bring the temperature difference to design conditions or minimum differential.

See the 19XR Installation Instructions manual for required chiller refrigerant charge or consult chiller nameplates.

If low load oil loss is experienced, operate the chiller at low load with the guide vanes nearly closed and observe the flow through the sight glass in the oil skimmer line. Under low load operation one should be able to see a flow of bubbly oil and refrigerant in the sight glass. If there is no visible flow, add refrigerant. If the sight glass shows a flow of nearly clear fluid remove refrigerant.

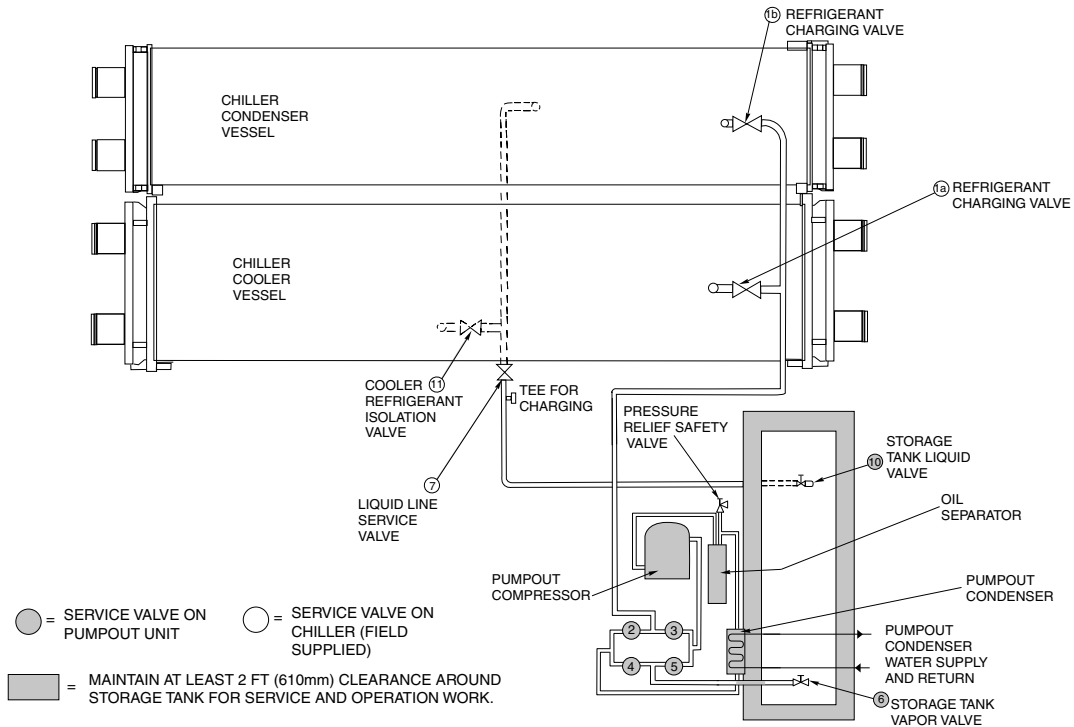

Fig. 33 — Typical Optional Pumpout System Piping Schematic with Storage Tank

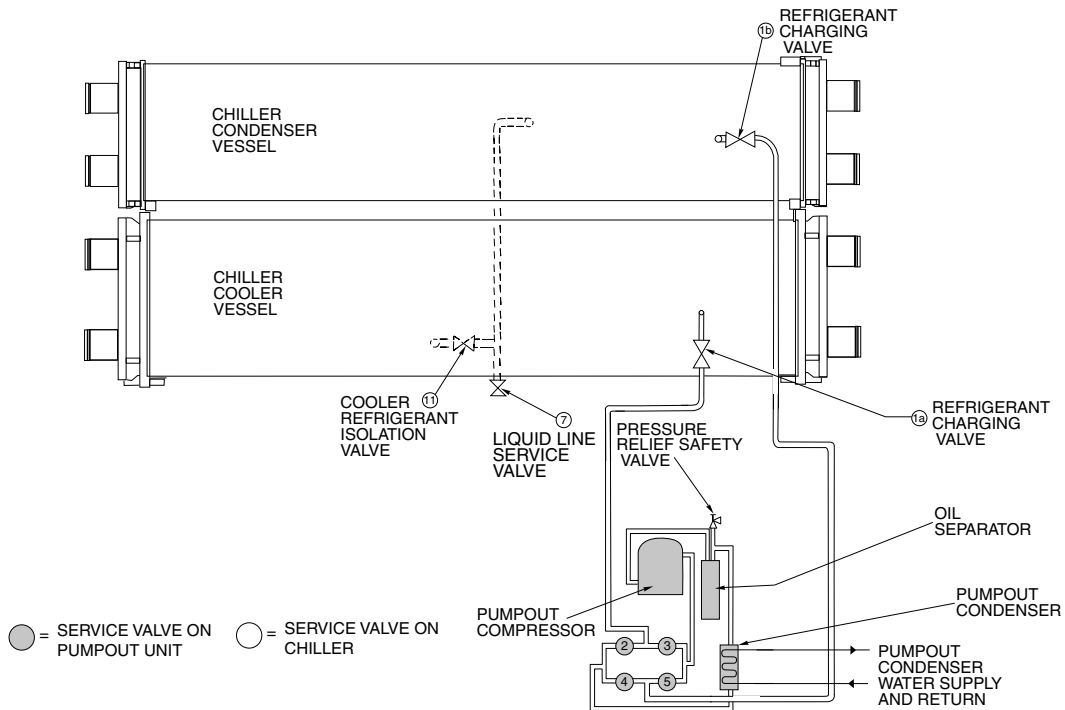

Fig. 34 — Typical Free-Standing Pumpout System Piping Schematic without Storage Tank

INITIAL START-UP

IMPORTANT: Startup engineer is to be properly certified for the starter/VFD. Extended VFD warranty may be affected.

Preparation

Before starting the chiller, verify:

1. Power is on to the main starter, oil pump relay, tower fan starter, oil heater relay, and the chiller control panel.
2. Cooling tower water is at proper level and at-or-below design entering temperature.
3. Chiller is charged with refrigerant and all refrigerant and oil valves are in their proper operating positions.
4. Oil is at the proper level in the reservoir sight glasses.
5. Oil reservoir temperature is above 140°F (60°C) or above CALC EVAP SAT TEMP plus 50°F (28°C).
6. Valves in the evaporator and condenser water circuits are open and water pressure differentials are equal to unit design. NOTE: If the pumps are not automatic, ensure water is circulating properly.

CAUTION

Do not permit water or brine that is warmer than 110°F (43°C) to flow through the cooler or condenser. Refrigerant overpressure may discharge through the relief valves and result in the loss of refrigerant charge.

7. Access the PUMPDOWN/LOCKOUT feature from the Maintenance Menu. Press the End Lockout button on the touch screen and accept the “press OK to Terminate Lockout?” prompt. The unit is reset to operating mode. The chiller is locked out at the factory in order to prevent accidental start-up.

Check Motor Rotation

1. Disengage the main starter disconnect and engage the control panel power circuit breaker.
NOTE: The circuit breaker may be located in the starter if the disconnect and step down transformer option was ordered with the starter. If located in the starter, close the door securely after this step.
2. Close the starter enclosure door.
3. The starter checks for proper phase rotation as soon as power is applied to the starter and the PIC 6 controls power up.
4. An alarm message will appear on the HMI screen if the phase rotation is incorrect. If this occurs reverse any 2 of the 3 incoming power leads to the starter and reapply power. The motor is now ready for a rotation check.
5. Start the chiller by Local On (assumes LOCAL operation mode) by pressing the Start/Stop button on the HMI and following the prompts. The PIC 6 control performs start-up checks.
6. When the starter is energized and the motor begins to turn, check for clockwise motor rotation (Fig. 35).

IMPORTANT: Do not check motor rotation during coast-down. Rotation may have reversed during equalization of vessel pressures.

Check Oil Pressure and Compressor Stop

1. When the motor is at full speed, note the differential oil pressure reading on the HMI default screen. It should be between 18 and 40 psid (124 and 206 kPad). The oil pump will generate design oil pressure only with the correct electrical phasing of ABC.
2. Press the Stop button and listen for any unusual sounds from the compressor as it coasts to a stop.



CORRECT MOTOR ROTATION IS CLOCKWISE WHEN VIEWED THROUGH MOTOR SIGHT GLASS

TO CHECK ROTATION, ENERGIZE COMPRESSOR MOTOR MOMENTARILY. DO NOT LET MACHINE DEVELOP CONDENSER PRESSURE. CHECK ROTATION IMMEDIATELY.

ALLOWING CONDENSER PRESSURE TO BUILD OR CHECKING ROTATION WHILE MACHINE COASTS DOWN MAY GIVE A FALSE INDICATION DUE TO GAS PRESSURE EQUALIZING THROUGH COMPRESSOR.

Fig. 35 — Correct Motor Rotation

To Prevent Accidental Start-Up

A chiller STOP override setting may be entered to prevent accidental start-up during service or whenever necessary. From the Main Menu, access the General Parameters Menu and use the down arrow to reach Stop Override on the GENUNIT table. Change Stop Override to Yes; then execute the command by touching the lightning button. The message “ALM-276 Protective Limit - Stop Override” will appear in the Home Screen message area. To restart the chiller, access the same screen and change the Stop Override option to No.

Check Chiller Operating Condition

Check to be sure that chiller temperatures, pressures, water flows, and oil and refrigerant levels indicate the system is functioning properly.

Instruct the Customer Operator

Ensure the operator(s) understands all operating and maintenance procedures. Point out the various chiller parts and explain their function as part of the complete system.

COOLER-CONDENSER

High side float chamber, relief valves, refrigerant charging valve, temperature sensor locations, pressure transducer locations, Schrader fittings, waterboxes and tubes, and vents and drains.

OPTIONAL PUMPOUT STORAGE TANK AND PUMPOUT SYSTEM

Transfer valves and pumpout system, refrigerant charging and pumpdown procedure, and relief devices.

MOTOR COMPRESSOR ASSEMBLY

Guide vane actuator, transmission, motor cooling system, oil cooling system, temperature and pressure sensors, oil sight glasses, integral oil pump, isolatable oil filter, extra oil and motor temperature sensors, synthetic oil, and compressor serviceability.

MOTOR COMPRESSOR LUBRICATION SYSTEM

Oil pump, cooler filter, oil heater, oil charge and specification, operating and shutdown oil level, temperature and pressure, and oil charging connections.

ECONOMIZER

Float valve, drain valve, Schrader fitting, damper valve.

CONTROL SYSTEM

CCN and LOCAL start, reset, menu, softkey functions, HMI operation, occupancy schedule, set points, safety controls, and auxiliary and optional controls.

AUXILIARY EQUIPMENT

Starters and disconnects, separate electrical sources, pumps, and cooling tower.

DESCRIBE CHILLER CYCLES

Refrigerant, motor cooling, lubrication, and oil reclaim.

REVIEW MAINTENANCE

Scheduled, routine, and extended shutdowns, importance of a log sheet, importance of water treatment and tube cleaning, and importance of maintaining a leak-free chiller.

SAFETY DEVICES AND PROCEDURES

Electrical disconnects, relief device inspection, and handling refrigerant.

CHECK OPERATOR KNOWLEDGE

Start, stop, and shutdown procedures, safety and operating controls, refrigerant and oil charging, and job safety.

REVIEW THE START-UP, OPERATION, AND MAINTENANCE MANUAL.

NOTE: Manuals and notebooks should not be stored under the VFD power module as they will block airflow into the power module cooling fan. Remove the manuals if they were placed under the power module during shipping.

OPERATING INSTRUCTIONS

Operator Duties

1. Become familiar with the chiller and related equipment before operating the chiller.
2. Prepare the system for start-up, start and stop the chiller, and place the system in a shutdown condition.
3. Maintain a log of operating conditions and document any abnormal readings.
4. Inspect the equipment, make routine adjustments, and perform a Control Test. Maintain the proper oil and refrigerant levels.
5. Protect the system from damage during shutdown periods.
6. Maintain the set point, time schedules, and other PIC functions.

Prepare the Chiller for Start-Up

Follow the steps described in the Initial Start-Up section, page 37.

To Start the Chiller

1. Start the water pumps, if they are not automatic.
2. Press the Start/Stop icon on the HMI home screen to start the system. If the chiller is in the OCCUPIED mode and the start timers have expired, the start sequence will start. Follow the procedure described in the Start-Up/Shutdown/Recycle Sequence section, page 19.

Check the Running System

After the compressor starts, the operator should monitor the display and observe the parameters for normal operating conditions:

1. The oil reservoir temperature should be above 120°F (49°C) during shutdown. Normal operating temperature is 120 to 165°F (49 to 74°C).
2. For 19XR2-E: The bearing oil temperature accessed on the TEMP screen should be 120 to 165°F (49 to 74°C) for compressors with rolling element bearings. If the bearing temperature reads more than 180°F (83°C) with the oil pump running, stop the chiller and determine the cause of the high temperature. *Do not restart* chiller until corrected. For 19XR6/7: The bearing temperature accessed from the Temperatures menu should be 140 to 210°F (60 to 99°C) for compressors with rolling element bearings. If the bearing

temperature is high or in Alarm/Alert state with the oil pump running, stop the chiller and determine the cause of the high temperature. *Do not restart* chiller until corrected.

3. The oil level should be visible anywhere in one of the two sight glasses. Foaming oil is acceptable as long as the oil pressure and temperature are within limits.
4. The oil pressure should be between 18 and 40 psid (124 and 207 kPa) differential, as seen on the HMI Transmission Status screen. Typically the reading will be 18 to 35 psid (124 to 241 kPa) at initial start-up.
5. The moisture indicator sight glass on the refrigerant motor cooling line should indicate refrigerant flow and a dry condition.
6. The condenser pressure and temperature varies with the chiller design conditions. Typically the pressure will range between 60 and 135 psig (390 and 950 kPa) with a corresponding temperature range of 60 to 105°F (15 to 41°C). The condenser entering water temperature should be controlled below the specified design entering water temperature to save on compressor kilowatt requirements.
7. Cooler pressure and temperature also will vary with the design conditions. Typical pressure range will be between 29.5 and 40.1 psig (203.4 and 276.4 kPa), with temperature ranging between 34 and 45°F (1.1 and 7.2°C).
8. The compressor may operate at full capacity for a short time after the pulldown ramping has ended, even though the building load is small. The active electrical demand setting can be overridden to limit the compressor kW, or the pulldown rate can be decreased to avoid a high demand charge for the short period of high demand operation. Pull-down rate can be based on load rate or temperature rate and is accessed on the **MAINTENANCE MENU** → **CAPACITY CONTROLS** → **RAMP_DEM** (Ramping Demand Limit Value).
9. The economizer (if installed) has two sight glasses that look into the float chamber. When the chiller is operating, the top sight glass is empty and the bottom sight glass is full.

To Stop the Chiller

The occupancy schedule starts and stops the chiller automatically once the time schedule is configured.

The unit can be stopped manually using the HMI by pressing the green Start/Stop icon . The Unit Start/Stop screen is displayed. Press Confirm Stop. The compressor will then follow the normal shutdown sequence as described in the Start-Up/Shutdown/Recycle Sequence section on page 19. The chiller is now in the OFF control mode.

IMPORTANT: Do not attempt to stop the chiller by opening an isolating knife switch. High intensity arcing may occur.

If the chiller is stopped by an alarm condition, *do not restart* chiller until the problem is diagnosed and corrected.

After Limited Shutdown

No special preparations should be necessary. Follow the regular preliminary checks and starting procedures.

Preparation for Extended Shutdown

The refrigerant should be transferred into the pumpout storage tank (if supplied; see Pumpout and Refrigerant Transfer Procedures on page 39) to reduce chiller pressure and the possibility of leaks. Maintain a holding charge of 5 to 10 lb (2.27 to 4.5 kg) of refrigerant or nitrogen to prevent air from leaking into the chiller.

For season chiller shutdown and lay-up, if the treated water is not drained then provisions should be made to start the pumps weekly to circulate the water and avoid corrosion. Consult the water treatment company for details. Carrier is not responsible for waterside corrosion.

If freezing temperatures are likely to occur in the chiller area, drain the chilled water, condenser water, and the pumpout condenser water circuits to avoid freeze-up. Keep the waterbox drains open. It is recommended not to store the refrigerant in the unit if below freezing temperatures are anticipated. A nitrogen holding charge is recommended in this case.

Leave the oil charge in the chiller with the oil heater and controls energized to maintain the minimum oil reservoir temperature.

After Extended Shutdown

Ensure the water system drains are closed. It may be advisable to flush the water circuits to remove any soft rust that may have formed. This is a good time to brush the tubes and inspect the Schrader fittings on the waterside flow devices for fouling, if necessary.

Check the cooler pressure on the HMI panel and compare it to the original holding charge that was left in the chiller. If (after adjusting for ambient temperature changes) any loss in pressure is indicated, check for refrigerant leaks. See Check Chiller Tightness section, page 21.

Recharge the chiller by transferring refrigerant from the pumpout storage tank (if supplied). Follow the Pumpout and Refrigerant Transfer Procedures section. Observe freeze-up precautions.

Carefully make all regular preliminary and running system checks. If the compressor oil level appears abnormally high, the oil may have absorbed refrigerant. Ensure that the oil temperature is above 40°F (4.4°C) or above the EVAP SAT TEMP plus 50°F (27°C).

Cold Weather Operation

When the entering condenser water temperature drops very low, the operator should automatically cycle the cooling tower fans off to keep the temperature up. Piping may also be arranged to bypass the cooling tower.

IMPORTANT: A field-supplied water temperature control system for condenser water should be installed. The system should maintain the leaving condenser water temperature at a temperature that is at least 20°F (11°C) above the leaving chilled water temperature.

Manual Guide Vane Operation

It is possible to manually operate the guide vanes in order to check control operation or to control the guide vanes in an emergency. Manual operation is possible by overriding the target guide vane position.

NOTE: Manual control overrides the configured pulldown rate during start-up and permits the guide vanes to open at a faster rate. Motor current above the electrical demand setting, capacity overrides, and chilled water temperature below the control

point override the manual target and close the guide vanes. For descriptions of capacity overrides and set points, see the 19XR with PIC 6 Controls Operation and Troubleshooting guide.

Refrigeration Log

A refrigeration log (as shown in Fig. 36), is a convenient checklist for routine inspection and maintenance and provides a continuous record of chiller performance. It is also an aid when scheduling routine maintenance and diagnosing chiller problems.

Keep a record of the chiller pressures, temperatures, and liquid levels on a sheet similar to the one in Fig. 36. Automatic recording of data is possible by using CCN devices such as the Data Collection module and a Building Supervisor. Contact a Carrier representative for more information.

PUMPOUT AND REFRIGERANT TRANSFER PROCEDURES

Preparation

The 19XR chiller may come equipped with an optional pumpout storage tank, pumpout system, or pumpout compressor. The refrigerant can be pumped for service work to either the chiller compressor vessel or chiller condenser vessel by using the optional pumpout system. If a pumpout storage tank is supplied, the refrigerant can be isolated in the storage tank. The following procedures describe how to transfer refrigerant from vessel to vessel and perform chiller evacuation.

⚠ CAUTION

The power to the pumpout compressor oil heater must be on whenever any valve connecting the pumpout compressor to the chiller or storage tank is open. Leaving the heater off will result in oil dilution by refrigerant and can lead to compressor failure.

If the compressor is found with the heater off and a valve open, the heater must be on for at least 4 hours to drive the refrigerant from the oil. When heating the oil the compressor suction must be open to a vessel to give the refrigerant a means to leave the compressor.

⚠ CAUTION

Always run the chiller cooler and condenser water pumps and always charge or transfer refrigerant as a gas when the chiller pressure is less than 35 psig (241 kPa). Below these pressures, liquid refrigerant flashes into gas, resulting in extremely low temperatures in the cooler/condenser tubes and possibly causing tube freeze-up.

⚠ DANGER

During transfer of refrigerant into and out of the optional storage tank, carefully monitor the storage tank level gage. Do not fill the tank more than 90% of capacity to allow for refrigerant expansion. Overfilling may result in damage to the tank or the release of refrigerant which will result in personal injury or death.

⚠ CAUTION

Do not mix refrigerants from chillers that use different compressor oils. Compressor damage can result.

Operating the Optional Pumpout Unit (Fig. 37)

Oil should be visible in the pumpout unit compressor sight glass under all operating conditions and during shutdown. If oil is low, add oil as described under Optional Pumpout System Maintenance section, page 50. The pumpout unit control wiring schematic is detailed in Fig. 38.

TO READ REFRIGERANT PRESSURES (during pumpout or leak testing):

1. The display on the chiller control panel is suitable for determining refrigerant-side pressures and low (soft) vacuum. To assure the desired range and accuracy when measuring evacuation and dehydration, use a quality vacuum indicator or manometer. This can be placed on the Schrader connections on each vessel by removing the pressure transducer (Fig. 3-5).
2. To determine pumpout storage tank pressure, a 30 in. Hg vacuum -0-400 psi (101-0-2758 kPa) gage is attached to the storage tank.
3. Refer to Fig. 33 and 34 for valve locations and numbers.

⚠ CAUTION

Transfer, addition, or removal of refrigerant in spring-isolated chillers may place severe stress on and damage external piping if springs have not been blocked in both up and down directions.

POSITIVE PRESSURE CHILLERS WITH STORAGE TANKS

In the Valve/Condition tables that accompany these instructions, the letter "C" indicates a closed valve. Figures 33 and 34 show the locations of the valves.

⚠ CAUTION

Always run chiller cooler and condenser water pumps and always charge or transfer refrigerant as a gas when chiller vessel pressure is less than 35 psig (241 kPa). Below these pressures, liquid refrigerant flashes into gas, resulting in extremely low temperatures in the cooler/condenser tubes and possibly causing tube freeze-up.

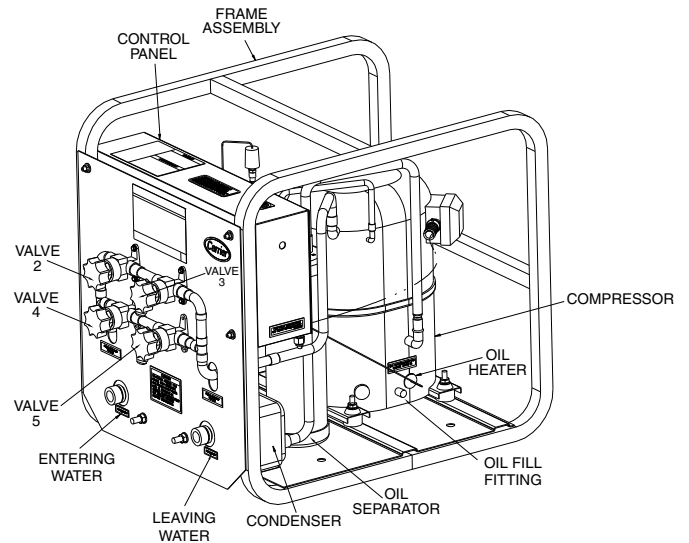

Fig. 37 — Pumpout Unit

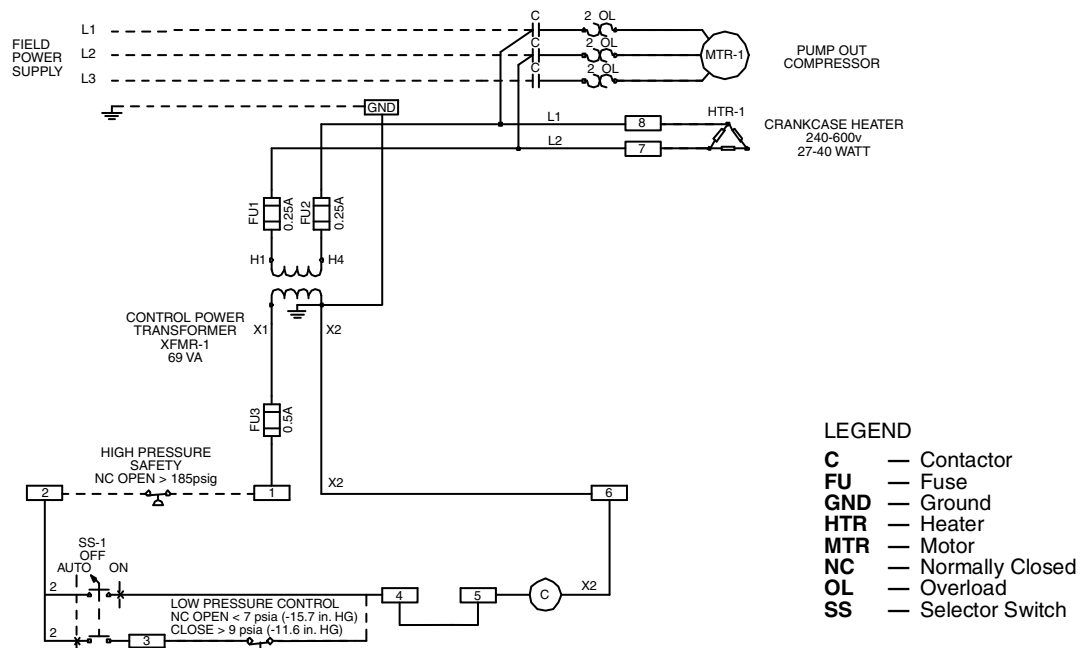

Fig. 38 — Pumpout Unit Wiring Schematic

LEGEND

- C** — Contactor
- FU** — Fuse
- GND** — Ground
- HTR** — Heater
- MTR** — Motor
- NC** — Normally Closed
- OL** — Overload
- SS** — Selector Switch

Transfer Refrigerant from Pumpout Storage Tank to Chiller

⚠ WARNING

During transfer of refrigerant into and out of the 19XR storage tank, carefully monitor the storage tank level gage. Do not fill the tank more than 90% of capacity to allow for refrigerant expansion. Overfilling may result in damage to the tank and personal injury.

1. Equalize refrigerant pressure.
 - a. Turn on chiller water pumps and monitor chiller pressures.
 - b. Close pumpout and storage tank valves 2, 4, 5, and 10, and close refrigerant charging valve 7; open chiller isolation valve 11 and any other chiller isolation valves, if present.
 - c. Open pumpout and storage tank valves 3 and 6; open chiller valves 1a and 1b.

VALVE	1A	1B	2	3	4	5	6	7	10	11
CONDITION			C		C	C		C	C	

- d. Gradually crack open valve 5 to increase chiller pressure to 35 psig (241 kPa). Slowly feed refrigerant to prevent freeze-up.
- e. Open valve 5 fully after the chiller pressure rises above the freezing point of the refrigerant. Let the storage tank and chiller pressure equalize. Open refrigerant charging valve 7 and storage tank charging valve 10 to let liquid refrigerant drain into the chiller.

VALVE	1A	1B	2	3	4	5	6	7	10	11
CONDITION			C		C					

2. Transfer remaining refrigerant.
 - a. Close valve 5 and open valve 4. Turn off pumpout condenser water, and turn on pumpout compressor in manual mode to push liquid refrigerant out of storage tank. Monitor the storage tank level until tank is empty.
 - b. Close refrigerant charging valves 7 and 10.
 - c. Turn off the pumpout compressor.
 - d. Turn off the chiller water pumps.
 - e. Close valves 3 and 4.
 - f. Open valves 2 and 5.

VALVE	1A	1B	2	3	4	5	6	7	10	11
CONDITION				C	C			C	C	

- g. Turn on pumpout condenser water.
- h. Run the pumpout compressor in manual mode until the storage tank pressure reaches 5 psig (34 kPa), 18 in. Hg vacuum (41 kPa absolute).
- i. Turn off the pumpout compressor.
- j. Close valves 1a, 1b, 2, 5, and 6.

VALVE	1A	1B	2	3	4	5	6	7	10	11
CONDITION	C	C	C	C	C	C	C	C	C	

- k. Turn off pumpout condenser water.

Transfer the Refrigerant from Chiller to Pumpout Storage Tank

1. Equalize refrigerant pressure.
 - a. Valve positions:

VALVE	1A	1B	2	3	4	5	6	7	10	11
CONDITION			C		C	C		C	C	

- b. Slowly open valve 5 and refrigerant charging valves 7 and 10 to allow liquid refrigerant to drain by gravity into the storage tank.

VALVE	1A	1B	2	3	4	5	6	7	10	11
CONDITION			C		C					

2. Transfer the remaining liquid.
 - a. Turn off pumpout condenser water. Place valves in the following positions:

VALVE	1A	1B	2	3	4	5	6	7	10	11
CONDITION				C	C					

- b. Run the pumpout compressor in automatic mode until vacuum switch is satisfied and compressor stops. Close valves 7 and 10.

VALVE	1A	1B	2	3	4	5	6	7	10	11
CONDITION				C	C			C	C	

- c. Turn off the pumpout compressor.

3. Remove any remaining refrigerant.
 - a. Turn on chiller water pumps.
 - b. Turn on pumpout condenser water.
 - c. Place valves in the following positions:

VALVE	1A	1B	2	3	4	5	6	7	10	11
CONDITION			C			C		C	C	

- d. Run the pumpout compressor until the chiller pressure reaches 35 psig (241 kPa); then shut off the pumpout compressor. Warm chiller condenser water will boil off any entrapped liquid refrigerant and chiller pressure will rise.
- e. When chiller pressure rises to 40 psig (276 kPa), turn on the pumpout compressor until the pressure again reaches 35 psig (241 kPa); then turn off the pumpout compressor. Repeat this process until the chiller pressure no longer rises; then turn on the pumpout compressor and pump out until the chiller pressure reaches 18 in. Hg vacuum (41 kPa absolute). This can be done in On or Automatic mode.
- f. Close valves 1a, 1b, 3, 4, and 6.

VALVE	1A	1B	2	3	4	5	6	7	10	11
CONDITION	C	C	C	C	C	C	C	C	C	

- g. Turn off the pumpout condenser water.

4. Establish vacuum for service. To conserve refrigerant, operate the pumpout compressor as described in Step 3e until the chiller pressure is reduced to 18 in. Hg vacuum (41 kPa absolute). This operation can be done in Automatic or On mode. In Automatic mode, the compressor will stop automatically at approximately 15 in. Hg vacuum (51 kPa absolute).

CHILLERS WITH ISOLATION VALVES

The valves referred to in the following instructions are shown in Fig. 33 and 34. Valve 7 remains closed.

Transfer All Refrigerant to Chiller Condenser Vessel

1. Push refrigerant into chiller condenser vessel.
 - a. Turn on the chiller water pumps and monitor the chiller pressure.
 - b. Valve positions:

VALVE	1A	1B	2	3	4	5	11
CONDITION				C	C		

- c. Equalize refrigerant in the chiller cooler and condenser.
- d. Turn off chiller water pumps and pumpout condenser water supply.
- e. Turn on pumpout compressor to push liquid out of the chiller cooler vessel.
- f. When all liquid has been pushed into the chiller condenser vessel, close the cooler refrigerant isolation valve (11).
- g. Turn on the chiller water pumps.

- h. Turn off the pumpout compressor.
- 2. Evacuate gas from chiller cooler vessel.
 - a. Close liquid line service valves 2 and 5; open valves 3 and 4.

VALVE	1A	1B	2	3	4	5	11
CONDITION			C			C	C

- b. Turn on pumpout condenser water.
- c. Run pumpout compressor until the chiller cooler vessel pressure reaches 18 in. Hg vacuum (41 kPa absolute). Monitor pressures on the chiller control panel and on refrigerant gages. This operation can be done in Automatic or On mode. In Automatic mode, the compressor will stop automatically at approximately 15 in. Hg vacuum (51 kPa absolute).
- d. Close valve 1a.
- e. Turn off pumpout compressor.
- f. Close valves 1b, 3, and 4.

VALVE	1A	1B	2	3	4	5	11
CONDITION	C	C	C	C	C	C	C

- g. Turn off pumpout condenser water.
- h. Turn off chiller water pumps and lock out chiller compressor.

Transfer All Refrigerant to Chiller Cooler Vessel

- 1. Push refrigerant into the chiller cooler vessel.
 - a. Turn on the chiller water pumps and monitor the chiller pressure.
 - b. Valve positions:

VALVE	1A	1B	2	3	4	5	11
CONDITION				C	C		

- c. Equalize refrigerant in the chiller cooler and condenser.
- d. Turn off chiller water pumps and pumpout condenser water.
- e. Turn on pumpout compressor to push refrigerant out of the chiller condenser.
- f. When all liquid is out of the chiller condenser, close valve 11 and any other liquid isolation valves on the chiller.
- g. Turn off the pumpout compressor.
- 2. Evacuate gas from chiller condenser vessel.
 - a. Turn on chiller water pumps.
 - b. Make sure that liquid line service valves 3 and 4 are closed and valves 2 and 5 are open.

VALVE	1A	1B	2	3	4	5	11
CONDITION				C	C		C

- c. Turn on pumpout condenser water.
- d. Run the pumpout compressor until the chiller condenser reaches 18 in. Hg vacuum (41 kPa absolute) in Manual or Automatic mode. Monitor pressure at the chiller control panel and refrigerant gages.
- e. Close valve 1b.
- f. Turn off pumpout compressor.
- g. Close valves 1a, 2, and 5.

VALVE	1A	1B	2	3	4	5	11
CONDITION	C	C	C	C	C	C	C

- h. Turn off pumpout condenser water.
- i. Turn off chiller water pumps and lock out chiller compressor.

Return Refrigerant to Normal Operating Conditions

- 1. Be sure that the chiller vessel that was opened has been evacuated.
- 2. Turn on chiller water pumps.
- 3. Open valves 1a, 1b, and 3.

VALVE	1A	1B	2	3	4	5	11
CONDITION			C		C	C	C

- 4. Crack open valve 5, gradually increasing pressure in the evacuated chiller vessel to 35 psig (241 kPa). Feed refrigerant slowly to prevent tube freeze-up.
- 5. Leak test to ensure chiller vessel integrity.
- 6. Open valve 5 fully.

VALVE	1A	1B	2	3	4	5	11
CONDITION			C		C		C

- 7. Close valves 1a, 1b, 3, and 5.
- 8. Open chiller isolation valve 11 and any other isolation valves, if present.

VALVE	1A	1B	2	3	4	5	11
CONDITION	C	C	C	C	C	C	

- 9. Turn off chiller water pumps.

DISTILLING THE REFRIGERANT

- 1. Transfer the refrigerant from the chiller to the pumpout storage tank as described in the Transfer the Refrigerant from Chiller to Pumpout Storage Tank section on page 42.
- 2. Equalize the refrigerant pressure.
 - a. Turn on chiller water pumps and monitor chiller pressures.
 - b. Close pumpout and storage tank valves 2, 4, 5, and 10, and close chiller charging valve 7; open chiller isolation valve 11 and any other chiller isolation valves, if present.
 - c. Open pumpout and storage tank valves 3 and 6; open chiller valves 1a and 1b.

VALVE	1A	1B	2	3	4	5	6	7	10	11
CONDITION			C		C	C		C	C	

- d. Gradually crack open valve 5 to increase chiller pressure to 35 psig (241 kPa). Slowly feed refrigerant to prevent freeze-up.
- e. Open valve 5 fully after the chiller pressure rises above the freezing point of the refrigerant. Let the storage tank and chiller pressure equalize.
- 3. Transfer remaining refrigerant.
 - a. Close valve 3.
 - b. Open valve 2.

VALVE	1A	1B	2	3	4	5	6	7	10	11
CONDITION				C	C			C	C	

- c. Turn on pumpout condenser water.
- d. Run the pumpout compressor until the storage tank pressure reaches 5 psig (34 kPa), 18 in. Hg vacuum (41 kPa absolute) in Manual or Automatic mode.
- e. Turn off the pumpout compressor.
- f. Close valves 1a, 1b, 2, 5, and 6.
- g. Turn off pumpout condenser water.

VALVE	1A	1B	2	3	4	5	6	7	10	11
CONDITION	C	C	C	C	C	C	C	C	C	

- 4. Drain the contaminants from the bottom of the storage tank into a container. Dispose of contaminants safely.

GENERAL MAINTENANCE

Refrigerant Properties

The standard refrigerants for the 19XR chiller are HFC-134a/R-513A. At normal atmospheric pressure, HFC-134a/R-513A will boil at -14°F (-25°C) / -28°F (-33°C) and must, therefore, be kept in pressurized containers or storage tanks. The refrigerant is practically odorless when mixed with air and is noncombustible at atmospheric pressure. Read the Material Safety Data Sheet and the latest ASHRAE Safety Guide for Mechanical Refrigeration to learn more about safe handling of this refrigerant.

⚠ DANGER

HFC-134a/R-513A will dissolve oil and some nonmetallic materials, dry the skin, and, in heavy concentrations, may displace enough oxygen to cause asphyxiation. When handling this refrigerant, protect the hands and eyes and avoid breathing fumes.

Adding Refrigerant

Follow the procedures described in Trim Refrigerant Charge section, this page.

⚠ CAUTION

Always use the compressor pumpdown function in the PUMPDOWN/LOCKOUT feature to turn on the cooler pump and lock out the compressor when transferring refrigerant. Liquid refrigerant may flash into a gas and cause possible freeze-up when the chiller pressure is below 35 psig (241 kPa) for HFC-134a or 39 psig (268 kPa) for R-513A.

Adjusting the Refrigerant Charge

If the addition or removal of refrigerant is required to improve chiller performance, follow the procedures given under the Trim Refrigerant Charge section, page 44.

Refrigerant Leak Testing

Because HFC-134a is above atmospheric pressure at room temperature, leak testing can be performed with refrigerant in the chiller. Use an electronic halogen leak detector, soap bubble solution, or ultrasonic leak detector. Ensure that the room is well ventilated and free from concentration of refrigerant to keep false readings to a minimum. Before making any necessary repairs to a leak, transfer all refrigerant from the leaking vessel.

Leak Rate

It is recommended by ASHRAE that chillers be taken off line immediately and repaired if the refrigerant leak rate for the entire chiller is more than 10% of the operating refrigerant charge per year.

In addition, Carrier recommends that leaks totaling less than the above rate but more than a rate of 0.1% of the total charge per year should be repaired during annual maintenance or whenever the refrigerant is transferred for other service work.

Test After Service, Repair, or Major Leak

If all the refrigerant has been lost or if the chiller has been opened for service, the chiller or the affected vessels must be pressure tested and leak tested. Refer to the Leak Test Chiller section on page 23 to perform a leak test.

⚠ WARNING

HFC-134a/HFO-513A should not be mixed with air or oxygen and pressurized for leak testing. In general, this refrigerant should not be present with high concentrations of air or oxygen above atmospheric pressures, because the mixture can undergo combustion.

TESTING WITH REFRIGERANT TRACER

Use an environmentally acceptable refrigerant as a tracer for leak test procedures. Use dry nitrogen to raise the machine pressure to leak testing levels.

TESTING WITHOUT REFRIGERANT TRACER

Another method of leak testing is to pressurize with nitrogen only and to use a soap bubble solution or an ultrasonic leak detector to determine if leaks are present.

TO PRESSURIZE WITH DRY NITROGEN

NOTE: Pressurizing with dry nitrogen for leak testing should not be done if the full refrigerant charge is in the vessel because purging the nitrogen is very difficult.

1. Connect a copper tube from the pressure regulator on the cylinder to the refrigerant charging valve. Never apply full cylinder pressure to the pressurizing line. Follow the listed sequence.
2. Open the charging valve fully.
3. Slowly open the cylinder regulating valve.
4. Observe the pressure gage on the chiller and close the regulating valve when the pressure reaches test level. *Do not exceed* 140 psig (965 kPa).
5. Close the charging valve on the chiller. Remove the copper tube if it is no longer required.

Repair the Leak, Retest, and Apply Standing Vacuum Test

After pressurizing the chiller, test for leaks with an electronic halide leak detector, soap bubble solution, or an ultrasonic leak detector. Bring the chiller back to atmospheric pressure, repair any leaks found, and retest.

After retesting and finding no leaks, apply a standing vacuum test. Then dehydrate the chiller. Refer to the Standing Vacuum Test and Chiller Dehydration sections (pages 23 and 25) in the Before Initial Start-Up section.

Checking Guide Vanes

During normal shutdown, when the chiller is off, the guide vanes are closed. Check that the coupling is tight on the shaft and make sure that the guide vane shaft is closed. Complete the following steps to adjust position (see Fig. 39-43):

1. Remove the set screw in the guide vane coupling.
2. Loosen the holddown bolts on the guide vane actuator.
3. Pull the guide vane actuator away from the suction housing.
4. If required, rotate the guide vane sprocket fully clockwise and spot-drill the guide vane actuator shaft. Spot-drilling is necessary when the guide vane actuator sprocket set screws on the guide vane actuator shaft need to be re-seated. (Remember: Spot-drill and tighten the first set screw before spot-drilling for the second set screw.)

Trim Refrigerant Charge

If to obtain optimal chiller performance it becomes necessary to adjust the refrigerant charge, operate the chiller at design load and then add or remove refrigerant slowly until the difference between the leaving chilled water temperature and the cooler refrigerant temperature reaches design conditions or becomes a minimum. *Do not overcharge.*

Refrigerant may be added either through the storage tank or directly into the chiller as described in the Charge Refrigerant into Chiller section.

To remove any excess refrigerant, follow the procedure in Transfer Refrigerant from Chiller to Pumpout Storage Tank section, Steps 1a and b, page 42.

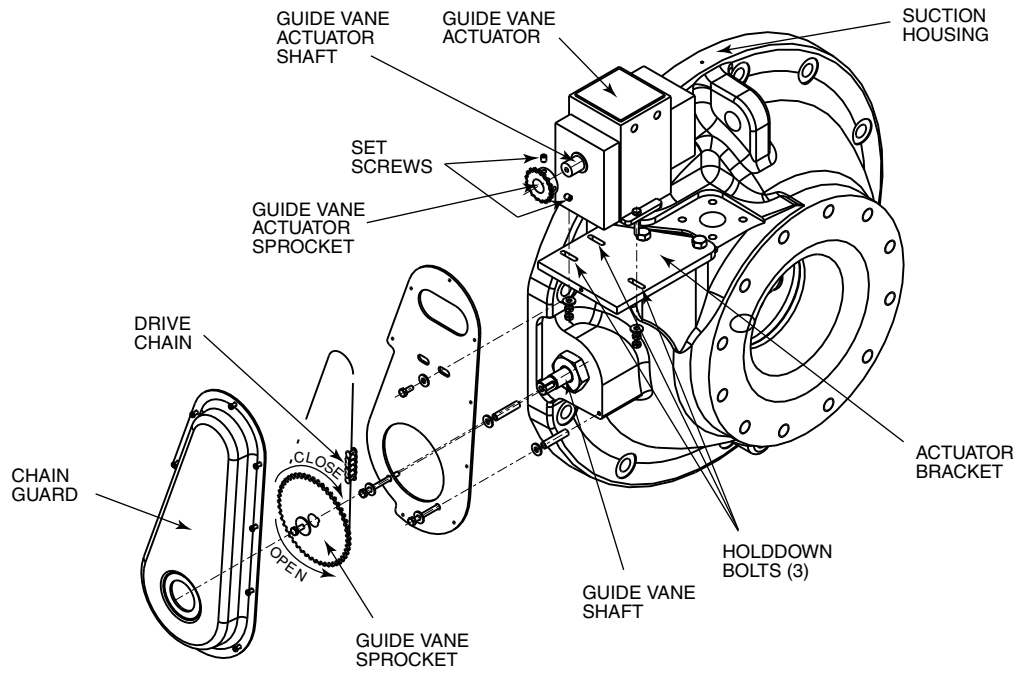

Fig. 39 — 19XR2,3,4,5,E Guide Vane Actuator Linkage

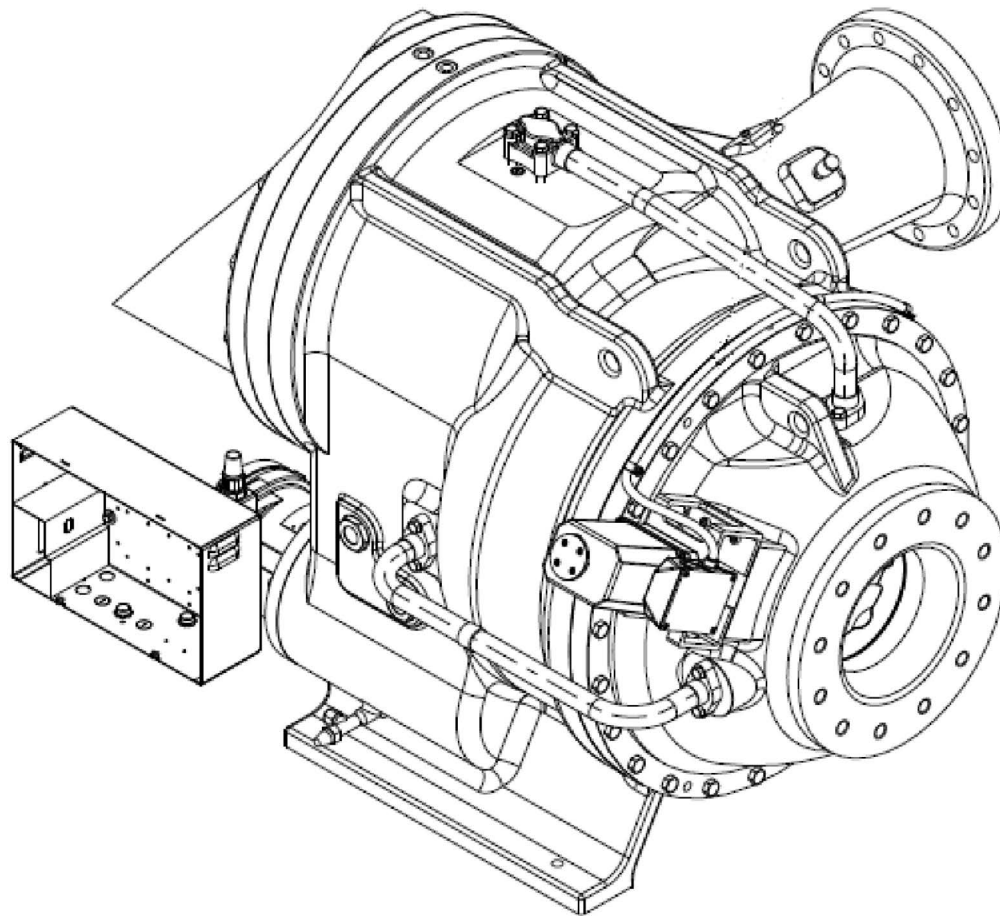

Fig. 40 — Guide Vane Actuator, Frame Size C

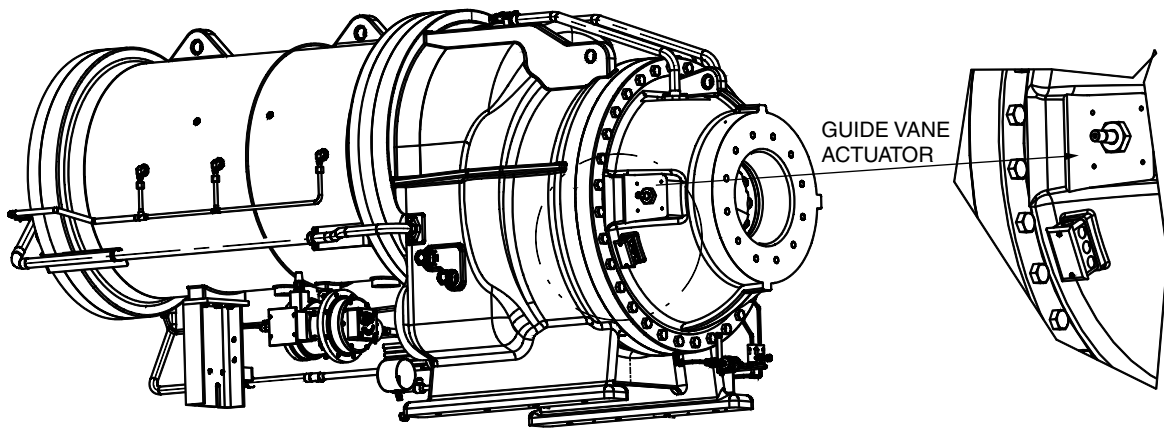

Fig. 41 — Guide Vane Actuator, Frame Size 6

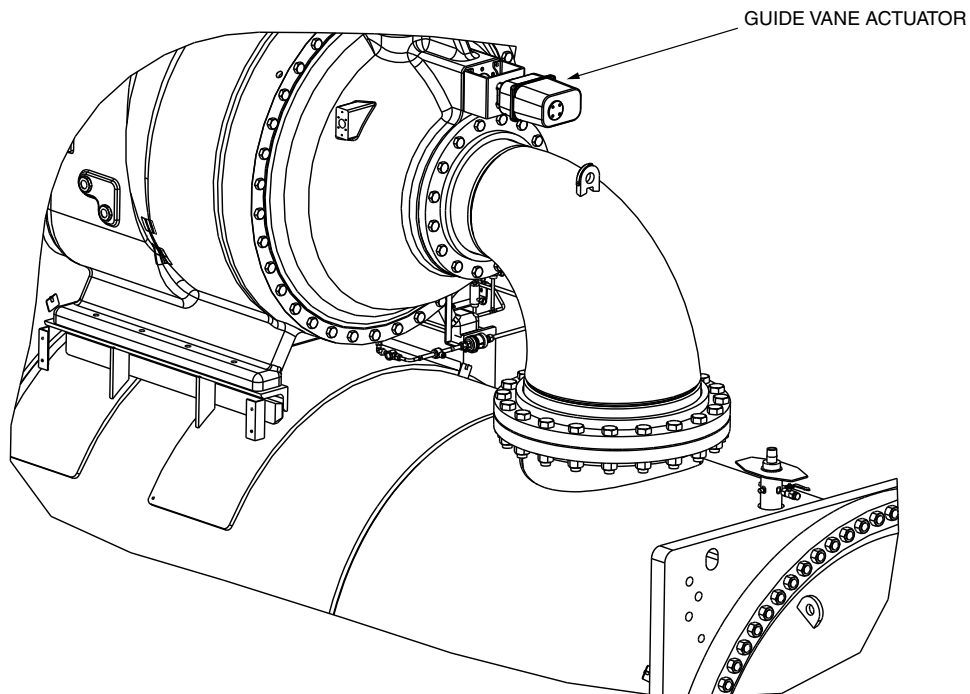
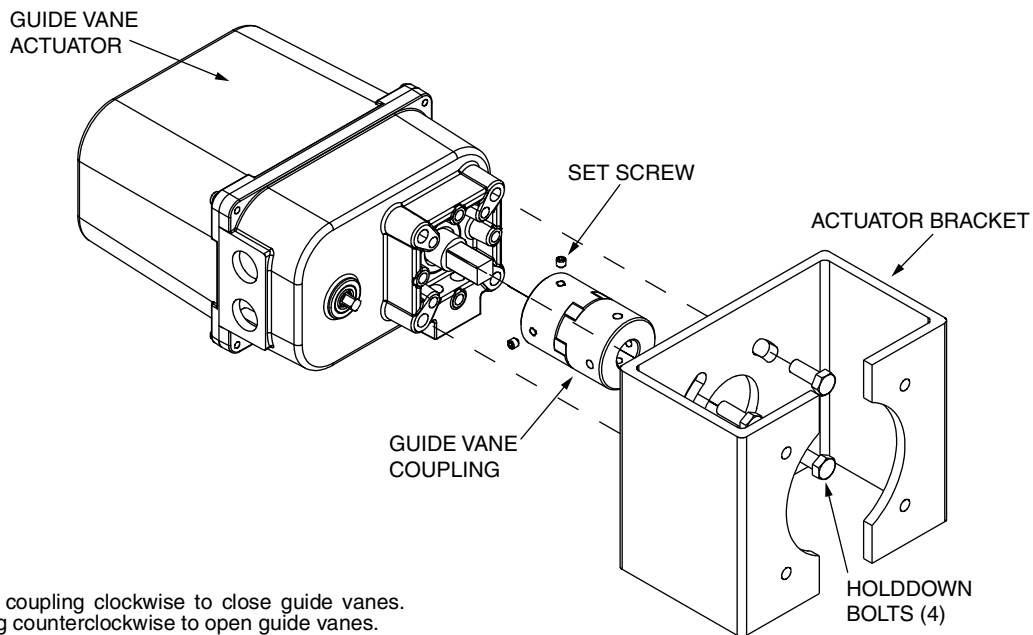

Fig. 42 — Guide Vane Actuator, Frame Size 7



NOTE: Rotate coupling clockwise to close guide vanes.
 Rotate coupling counterclockwise to open guide vanes.

Fig. 43 — Guide Vane Actuator Detail for XRC, XR6, XR7 (Typical)

WEEKLY MAINTENANCE

Check the Lubrication System

Mark the oil level on the reservoir sight glass, and observe the level each week while the chiller is shut down.

If the level goes below the lower sight glass, check the oil reclaim system for proper operation. If additional oil is required, add it through the oil drain charging valve (Fig. 3-5). A pump is required when adding oil against refrigerant pressure. See “Oil Charge” on page 28 for 19XR compressor family oil charge.

The added oil *must* meet Carrier specifications for the 19XR chiller. Refer to Changing Oil Filter and Oil Changes sections. Any additional oil that is added should be logged by noting the amount and date. Any oil that is added due to oil loss that is not related to service will eventually return to the sump. It must be removed when the level is high.

An oil heater is controlled by the PIC 6 control system to maintain oil temperature (see the 19XR with PIC 6 Controls Operation and Troubleshooting manual) when the compressor is off. If the PIC 6 control system shows that the heater is energized and if the sump is still not heating up, the power to the oil heater may be off or the oil level may be too low. Check the oil level, the oil heater contactor voltage, and oil heater resistance.

The PIC 6 control system does not permit compressor start-up if the oil temperature is too low. The PIC 6 control system continues with start-up only after the temperature is within allowable limits.

SCHEDULED MAINTENANCE

Establish a regular maintenance schedule based on your actual chiller requirements such as chiller load, run hours, and water quality. *The time intervals listed in this section are offered as guides to service only.*

Service Ontime

The HMI will display a SERVICE ONTIME value on the **MAIN MENU** → **RUN TIMES** screen. This value should be reset to zero by the service person or the operator each time major service work is completed so that the time between service events can be viewed and tracked.

Inspect the Control Panel

Maintenance consists of general cleaning and tightening of connections. Vacuum the cabinet to eliminate dust build-up. If the chiller control malfunctions, refer to the Troubleshooting Guide section on page 51 for control checks and adjustments.

⚠ WARNING

Ensure power to the starter is isolated when cleaning and tightening connections inside the starter enclosure. Failure to disconnect power could result in electrocution. The oil filter housing is at a high pressure. Relieve this pressure slowly. Failure to do so could result in serious personal injury.

Changing Oil Filter

Change the oil filter on a yearly basis or when the chiller is opened for repairs. The 19XR chiller has an isolatable oil filter so that the filter may be changed with the refrigerant remaining in the chiller. Use the following procedure:

1. Ensure the compressor is off and the disconnect for the compressor is open.
2. Disconnect the power to the oil pump.
3. Close the oil filter isolation valves.
4. Close the isolation valves located on both ends of the oil filter. Have rags and a catch basin available to collect oil spillage.

5. Equalize the filter's higher internal pressure to ambient by connecting an oil charging hose to the Schrader valve on the oil filter housing. Collect the oil-refrigerant mixture which is discharged.
6. Remove the oil filter assembly by loosening the hex nuts on both ends of the filter assembly.
7. Insert the replacement filter assembly with the arrow on the housing pointing away from the oil pump.
8. Rotate the assembly so that the Schrader drain valve is oriented at the bottom, and tighten the connection nut on each end to a torque of approximately 30 ft-lb (41 N-m).

⚠ WARNING

The oil filter housing is at a high pressure. Relieve this pressure slowly. Failure to do so could result in serious personal injury.

9. Evacuate the filter housing by placing a vacuum pump on the charging valve. Follow the normal evacuation procedures. Shut the charging valve when done and reconnect the valve so that new oil can be pumped into the filter housing. Fill with the same amount that was removed; then close the charging valve.
10. Remove the hose from the charging valve, open the isolation valves to the filter housing, and turn on the power to the pump and the motor.

Oil Specification

If oil is added, it must meet Carrier specifications. For units using R-134a/R-513A, use inhibited polyolester-based synthetic compressor oil formatted for use with HFC, gear-driven, hermetic compressors, with ISO Viscosity Grade 68. The polyolester-based oil (P/N: PP23BZ103) may be ordered from your local Carrier representative.

Oil Changes

Carrier recommends that a yearly oil analysis be performed to determine when to change oil and when to perform a compressor inspection. However, if yearly analysis is not performed or available, the time between oil changes should be no longer than 5 years. Additionally Carrier recommends vibration measurement done at regular intervals to obtain a signature of the moving compressor parts as part of a total preventive maintenance (TPM) program.

TO CHANGE THE OIL

1. Transfer the refrigerant into the chiller condenser vessel (for isolatable vessels) or to a pumpout storage tank.
2. Mark the existing oil level.
3. Open the control and oil heater circuit breaker.
4. When the chiller pressure is 5 psig (34 kPa) or less, drain the oil reservoir by opening the oil charging valve (Fig. 3-5). Slowly open the valve against refrigerant pressure.
5. Change the oil filter at this time. See Changing Oil Filter section.
6. Change the refrigerant filter at this time. See the next section, Refrigerant Filter.
7. Charge the chiller with oil. Charge until the oil level is equal to the oil level marked in Step 2. Turn on the power to the oil heater and let the PIC 6 warm it up to at least 140°F (60°C). Operate the oil pump manually, using the Control Test function, for 2 minutes. For shutdown conditions, the oil level should be full in the lower sight glass. If the oil level is above 1/2 full in the upper sight glass, remove the excess oil. The oil level should now be equal to the amount shown in Step 2.

Refrigerant Filter

A refrigerant filter/drier, located on the refrigerant cooling line to the motor, should be changed once a year or more often if filter

condition indicates a need for more frequent replacement. Change the filter by closing the filter isolation valves (Fig. 3-5) and slowly opening the flare fittings with a wrench and back-up wrench to relieve the pressure. A moisture indicator sight glass is located beyond this filter to indicate the volume and moisture in the refrigerant. If the moisture indicator indicates moisture, locate the source of water immediately by performing a thorough leak check.

VFD Refrigerant Strainer (if equipped)

A refrigerant strainer is located in the 5/8 in. line that supplies refrigerant to the VFD. The strainer should be replaced once a year or more often if the strainer condition indicates a need for more frequent replacement. Change the filter by closing the refrigerant cooling line isolation valves. Refrigerant pressure can be relieved through access valves on the strainer housing. Tighten 5/8 in. flare nuts to 55 to 66 ft-lb (75 to 89 Nm).

Oil Reclaim Filter

The oil reclaim system has a strainer on the eductor suction line, a strainer on the discharge pressure line, and a filter on the cooler scavenging line. Replace the filter once every 5 years or when the machine is opened for service. This filter does not contain desiccant for moisture removal, so changing the filter will not change the moisture indicator status. Change the filter by closing the filter isolation valves and slowly opening the flare fitting with a wrench and back-up wrench to relieve the pressure. Change the strainers once every 5 years or whenever refrigerant is evacuated from the cooler.

Inspect Refrigerant Float System

Perform this inspection only if the following symptoms are seen.

- There is a simultaneous drop in cooler pressure and increase in condenser pressure. This will be accompanied by an increase in kW/Ton.
 - The liquid line downstream of the float valve feels warm. This indicates condenser gas flowing past the float. An increase in kW/Ton will also occur.
1. Transfer the refrigerant into the cooler vessel or into a pumpout storage tank.
 2. Remove the float access cover.
 3. Clean the chamber and valve assembly thoroughly. Be sure the valve moves freely. Ensure that all openings are free of obstructions.
 4. Examine the cover gasket and replace if necessary. For linear style float valves inspect the orientation of the float slide pin. It must be pointed toward the bubbler tube for proper operation.

Note there are two styles of float valves in use on the 19XR product line. Linear float valve (Fig 44) and ball float valves (Fig. 45).

ECONOMIZER FLOAT SYSTEM (IF EQUIPPED)

For two-stage compressors, the economizer has a low side ball type float system. The float refrigerant level can be observed through the two sight glasses located on the float cover under the condenser. See Fig. 45 for float detail. Inspect the float every five years. Clean the chamber and the float valve assembly. Be sure that the float moves freely and the ball bearings that the float moves on are clean.

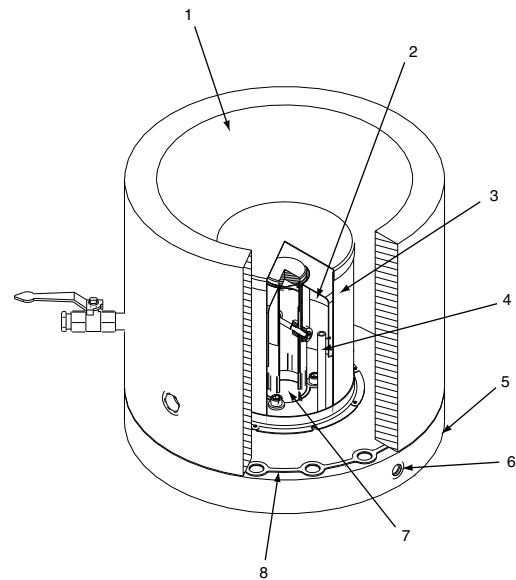

LEGEND

- 1 — Refrigerant Inlet from FLASC Chamber
- 2 — Linear Float Assembly
- 3 — Float Screen
- 4 — Bubbler Line
- 5 — Float Cover
- 6 — Bubbler Line Connection
- 7 — Refrigerant Outlet to Cooler
- 8 — Gasket

Fig. 44 — Linear Float Valve Design

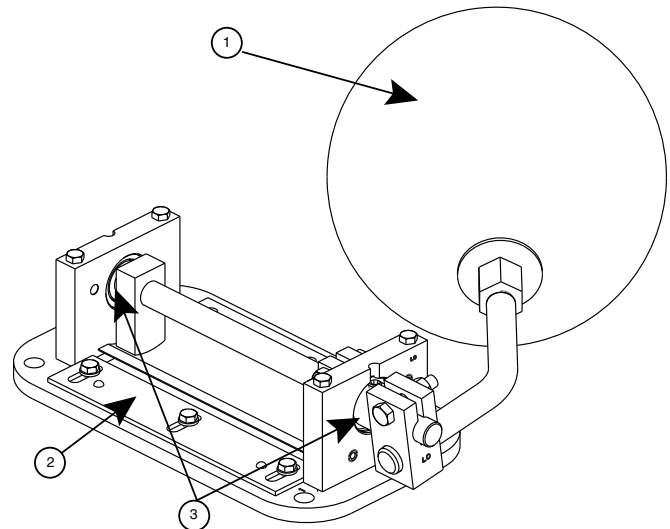

LEGEND

- 1 — Float Ball
- 2 — Refrigerant Exit
- 3 — Bearings

Fig. 45 — Economizer Float System (Two-Stage Compressor Chiller)

ECONOMIZER DAMPER VALVE

The damper valve operation should be inspected annually (external inspection) and internally when the refrigerant is removed and it has been more than 5 years since last inspection or initial start-up. See Fig. 46 for economizer damper valve detail.

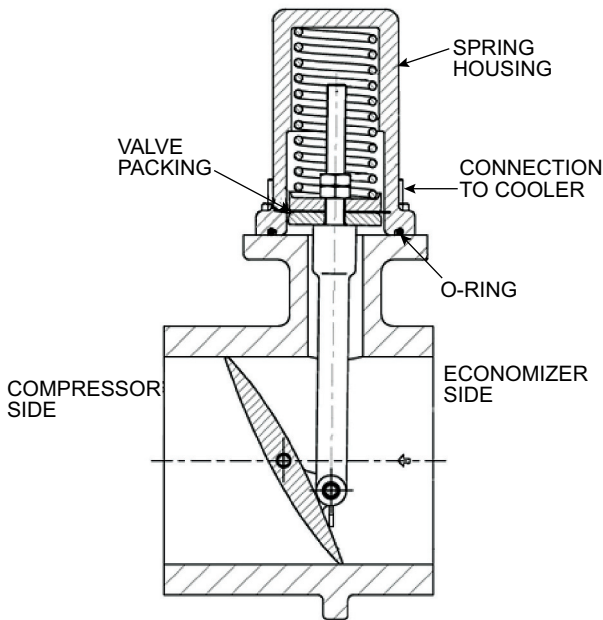

NOTE: Two Stage 19XR6-7 utilizes an electrical actuated butterfly valve as damper valve.

Fig. 46 — Economizer Damper Valve (Two-Stage 19XRC, E Compressor Chiller)

Inspect Relief Valves and Piping

The relief valves on this chiller protect the system against the potentially dangerous effects of overpressure. To ensure against damage to the equipment and possible injury to personnel, these devices must be kept in peak operating condition.

As a minimum, the following maintenance is required.

1. At least once a year, disconnect the vent piping at the valve outlet and carefully inspect the valve body and mechanism for any evidence of internal corrosion or rust, dirt, scale, leakage, etc.
2. If corrosion or foreign material is found, do not attempt to repair or recondition. *Replace the valve.*
3. If the chiller is installed in a corrosive atmosphere or the relief valves are vented into a corrosive atmosphere, inspect the relief valves at more frequent intervals.

Compressor Bearing and Gear Maintenance

The key to good bearing and gear maintenance is proper lubrication. Use the proper grade of oil, maintained at recommended level, temperature, and pressure. Inspect the lubrication system regularly and thoroughly. Annual oil analysis and vibration measurements are recommended.

Excessive bearing wear can sometimes be detected through increased vibration or increased bearing temperature. Gears, babbitted journal bearings, and thrust bearings should be examined for signs of wear based on the results of the annual oil analysis and vibration levels. To inspect the bearings, a complete compressor teardown is required. Only a trained service technician should remove and examine the bearings. The frequency of examination is determined by the hours of chiller operation, load conditions during operation, and the condition of the oil and the lubrication system. High speed shaft rolling element bearings cannot be field inspected; excessive vibration is the primary sign of wear or damage. If either symptom appears, contact an experienced and responsible service organization for assistance.

Inspect the Heat Exchanger Tubes and Flow Devices

COOLER AND OPTIONAL FLOW DEVICES

Inspect and clean the cooler tubes at the end of the first operating season. Confirm that there is no foreign debris from the system that could have lodged in the tubes potentially resulting in tube failure. Because these tubes have internal ridges, a rotary-type tube cleaning system is needed to fully clean the tubes. Inspect the tubes' condition to determine the scheduled frequency for future cleaning and to determine whether water treatment in the chilled water/brine circuit is adequate. Inspect the entering and leaving chilled water temperature sensors and flow devices for signs of corrosion or scale. Replace a sensor or Schrader fitting if corroded or remove any scale if found.

CONDENSER AND OPTIONAL FLOW DEVICES

Since this water circuit is usually an open-type system, the tubes may be subject to contamination and scale. Clean the condenser tubes with a rotary tube cleaning system at least once per year and more often if the water is contaminated. Confirm that there is no foreign debris from the system that could have lodged in the tubes potentially resulting in tube failure. Inspect the entering and leaving condenser water sensors and flow devices for signs of corrosion or scale. Replace the sensor or Schrader fitting if corroded or remove any scale if found.

Higher than normal condenser pressures, together with the inability to reach full refrigeration load, usually indicate dirty tubes or air in the chiller. If the refrigeration log indicates a rise above normal condenser pressures, check the condenser refrigerant temperature against the leaving condenser water temperature. If this reading is more than what the design difference is supposed to be, the condenser tubes may be dirty or water flow may be incorrect. Because HFC-134a is a high-pressure refrigerant, air usually does not enter the chiller.

During the tube cleaning process, use brushes specially designed to avoid scraping and scratching the tube wall. Contact your Carrier representative to obtain these brushes. Do not use wire brushes.

Hard scale may require chemical treatment for its prevention or removal. Consult a water treatment specialist for proper treatment.

Water Leaks

The refrigerant moisture indicator on the refrigerant motor cooling line (Fig. 3-5) indicates whether there is water leakage during chiller operation. Water leaks should be repaired immediately.

⚠ CAUTION

The chiller must be dehydrated after repair of water leaks or damage may result. See Chiller Dehydration section, page 25.

Water Treatment

Untreated or improperly treated water may result in corrosion, scaling, erosion, or algae. The services of a qualified water treatment specialist should be obtained to develop and monitor a treatment program.

⚠ CAUTION

Water must be within design flow limits, clean, and treated to ensure proper chiller performance and reduce the potential of tube damage due to corrosion, scaling, erosion, and algae. Carrier assumes no responsibility for chiller damage resulting from untreated or improperly treated water.

Inspect the Starting Equipment or VFD

Before working on any starter, shut off the chiller, open and tag all disconnects supplying power to the starter.

⚠ CAUTION

The motor leads must be disconnected from the starter before an insulation test is performed. The voltage generated from the tester can damage the starter components.

⚠ WARNING

The disconnect on the starter/VFD front panel does not always de-energize all internal circuits. Open all internal and remote disconnects before servicing the starter. Failure to follow this procedure may result in personal injury by electric shock.

⚠ WARNING

Never open isolating knife switches while equipment is operating. Electrical arcing can cause serious injury.

Periodically vacuum accumulated debris on the internal parts. Use electrical cleaner for electrical parts as required.

Power connections on newly installed starters may relax and loosen after a month of operation. Turn power off and retighten. Recheck annually thereafter.

⚠ CAUTION

Loose power connections can cause voltage spikes, overheating, malfunctioning, or failures.

Recalibrate Pressure Transducers

Once a year, the pressure transducers should be checked against a pressure gage reading. Check all eight transducers: the 2 oil differential pressure transducers, the condenser pressure transducer, the cooler pressure transducer, and the optional waterside pressure transducer pairs (consisting of 4 flow devices: 2 cooler, 2 condenser). For details, see page 55.

Optional Pumpout System Maintenance

For pumpout unit compressor maintenance details, refer to the 19XR Positive Pressure Storage System Installation, Start-Up, and Service Instructions.

OPTIONAL PUMPOUT COMPRESSOR OIL CHARGE

Use oil conforming to Carrier specifications for reciprocating compressor usage. Oil requirements are as follows:

ISO Viscosity	68 or 220
Carrier Part Number	PP23BZ103 or PP23BZ104

The total oil charge is 13 oz. (0.5 L).

Oil should be visible in the pumpout compressor sight glass both during operation and at shutdown. Always check the oil level before operating the pumpout compressor. Before adding changing oil, relieve the refrigerant pressure through the access valves.

Relieve refrigerant pressure and add oil to the pumpout unit as follows:

1. Close service valves 2 and 4.
2. Run the pumpout compressor in Automatic mode for one minute or until the vacuum switch is satisfied and compressor shuts off.
3. Move the pumpout selector switch to OFF. Pumpout compressor shell should now be under vacuum.
4. Oil can be added to the shell with a hand oil pump through the access valve in the compressor base.

NOTE: The compressor access valve has a self-sealing fitting which will require a hose connection with a depressor to open.

OPTIONAL PUMPOUT SAFETY CONTROL SETTINGS (FIG. 47)

The optional pumpout system high-pressure switch opens at 185 psig (1276 kPa) and closes at 140 psig (965 kPa). Check the switch setting by operating the pumpout compressor and slowly throttling the pumpout condenser water.

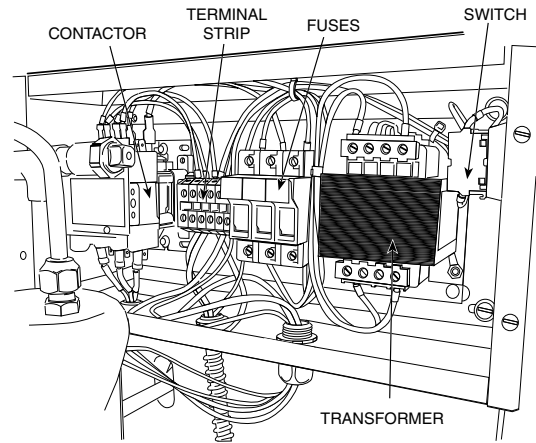

Fig. 47 — Pumpout Control Box (Interior)

Ordering Replacement Chiller Parts

When ordering Carrier specified parts, the following information must accompany an order:

- chiller model number and serial number
- name, quantity, and part number of the part required
- delivery address and method of shipment.

TROUBLESHOOTING GUIDE

Overview

The PIC 6 control system has many features to help the operator and technician troubleshoot a 19XR chiller.

- The HMI shows the chiller's actual operating conditions and can be viewed while the unit is running.
- The HMI default screen indicates when an alarm occurs. Once all alarms have been cleared (by correcting the problems), the HMI default screen indicates normal operation. For information about displaying and resetting alarms and a list of alert codes, see the 19XR with PIC 6 Controls Operation and Troubleshooting manual.
- The Configuration menu screens display information that helps to diagnose problems with chilled water temperature control, chilled water temperature control overrides, hot gas bypass, surge algorithm status, and time schedule operation.
- The quick test feature facilitates the proper operation and test of temperature sensors, pressure transducers, the guide vane actuator, diffuser actuator (if equipped), oil pump, water pumps, tower control, and other on/off outputs while the compressor is stopped. It also has the ability to lock off the compressor and turn on water pumps for pumpout operation. The HMI shows the temperatures and pressures required during these operations.
- If an operating fault is detected, an alarm indicator is displayed on the HMI default screen. A more detailed message — along with a diagnostic message — is also stored in the Current Alarms table.
- Review the Alarms History table to view other less critical events which may have occurred. Compare timing of relevant events and alarms.

For detailed information about alarms, see the 19XR with PIC 6 Controls Operation and Troubleshooting manual. Press the bell icon in the top right corner of the home screen to access current alarms and alarm history, and to reset alarms.

Checking Display Messages

The first area to check when troubleshooting the 19XR is the HMI display. Status messages are displayed at the bottom of the screen, and the alarm icon indicates a fault. For a complete list of alarms, see the 19XR with PIC 6 Controls Operation and Troubleshooting manual.

Checking Temperature Sensors

All temperature sensors are thermistor-type sensors. This means that the resistance of the sensor varies with temperature. All sensors have the same resistance characteristics. If the controls are on, determine sensor temperature by measuring voltage drop; if the controls are powered off, determine sensor temperature by measuring resistance. Compare the readings to the values listed in Tables 13 and 14. The water temperature sensors can be calibrated to a value of $\pm 2.0^{\circ}\text{F}$ (1.2°C).

RESISTANCE CHECK

Turn off the control power and, from the module, disconnect the terminal plug of the sensor in question. With a digital ohmmeter, measure sensor resistance between receptacles as designated by the wiring diagram. The resistance and corresponding temperature are listed in Tables 13 and 14. Check the resistance of both wires to ground. This resistance should be infinite.

VOLTAGE DROP

The voltage drop across any energized sensor can be measured with a digital voltmeter while the control is energized. Tables 13 and 14 list the relationship between temperature and sensor voltage drop (volts dc measured across the energized sensor). Exercise care when measuring voltage to prevent damage to the sensor leads, connector plugs, and modules. Sensors should also be checked at the sensor plugs.

CAUTION

Relieve all refrigerant pressure or drain the water before removing any thermowell threaded into the refrigerant pressure boundary. Failure to do so could result in personal injury and equipment damage.

Table 13 — Thermistor Temperature (F) vs. Resistance/Voltage Drop

TEMPERATURE (F)	PIC VOLTAGE DROP (V)	RESISTANCE (OHMS)	TEMPERATURE (F)	PIC VOLTAGE DROP (V)	RESISTANCE (OHMS)	TEMPERATURE (F)	PIC VOLTAGE DROP (V)	RESISTANCE (OHMS)
-25	4.700	97,706	66	2.565	6,568	157	0.630	893
-24	4.690	94,549	67	2.533	6,405	158	0.619	876
-23	4.680	91,474	68	2.503	6,246	159	0.609	859
-22	4.670	88,480	69	2.472	6,092	160	0.599	843
-21	4.659	85,568	70	2.440	5,942	161	0.589	827
-20	4.648	82,737	71	2.409	5,796	162	0.579	812
-19	4.637	79,988	72	2.378	5,655	163	0.570	797
-18	4.625	77,320	73	2.347	5,517	164	0.561	782
-17	4.613	74,734	74	2.317	5,382	165	0.551	768
-16	4.601	72,229	75	2.287	5,252	166	0.542	753
-15	4.588	69,806	76	2.256	5,124	167	0.533	740
-14	4.576	67,465	77	2.227	5,000	168	0.524	726
-13	4.562	65,205	78	2.197	4,880	169	0.516	713
-12	4.549	63,027	79	2.167	4,764	170	0.508	700
-11	4.535	60,930	80	2.137	4,650	171	0.499	687
-10	4.521	58,915	81	2.108	4,539	172	0.491	675
-9	4.507	56,981	82	2.079	4,432	173	0.484	663
-8	4.492	55,129	83	2.050	4,327	174	0.476	651
-7	4.477	53,358	84	2.021	4,225	175	0.468	639
-6	4.461	51,669	85	1.993	4,125	176	0.460	628
-5	4.446	50,062	86	1.965	4,028	177	0.453	616
-4	4.429	48,536	87	1.937	3,934	178	0.445	605
-3	4.413	47,007	88	1.909	3,843	179	0.438	595
-2	4.396	45,528	89	1.881	3,753	180	0.431	584
-1	4.379	44,098	90	1.854	3,667	181	0.424	574
0	4.361	42,715	91	1.827	3,582	182	0.418	564
1	4.344	41,380	92	1.800	3,500	183	0.411	554
2	4.325	40,089	93	1.773	3,420	184	0.404	544
3	4.307	38,843	94	1.747	3,342	185	0.398	535
4	4.288	37,639	95	1.721	3,266	186	0.392	526
5	4.269	36,476	96	1.695	3,192	187	0.385	516
6	4.249	35,354	97	1.670	3,120	188	0.379	508
7	4.229	34,270	98	1.644	3,049	189	0.373	499
8	4.209	33,224	99	1.619	2,981	190	0.367	490
9	4.188	32,214	100	1.595	2,914	191	0.361	482
10	4.167	31,239	101	1.570	2,849	192	0.356	474
11	4.145	30,298	102	1.546	2,786	193	0.350	466
12	4.123	29,389	103	1.523	2,724	194	0.344	458
13	4.101	28,511	104	1.499	2,663	195	0.339	450
14	4.079	27,663	105	1.476	2,605	196	0.333	442
15	4.056	26,844	106	1.453	2,547	197	0.328	435
16	4.033	26,052	107	1.430	2,492	198	0.323	428
17	4.009	25,285	108	1.408	2,437	199	0.318	421
18	3.985	24,544	109	1.386	2,384	200	0.313	414
19	3.960	23,826	110	1.364	2,332	201	0.308	407
20	3.936	23,130	111	1.343	2,282	202	0.304	400
21	3.911	22,455	112	1.321	2,232	203	0.299	393
22	3.886	21,800	113	1.300	2,184	204	0.294	387
23	3.861	21,163	114	1.279	2,137	205	0.290	381
24	3.835	20,556	115	1.259	2,092	206	0.285	374
25	3.808	19,967	116	1.239	2,047	207	0.281	368
26	3.782	19,396	117	1.219	2,003	208	0.277	362
27	3.755	18,843	118	1.200	1,961	209	0.272	356
28	3.727	18,307	119	1.180	1,920	210	0.268	351
29	3.700	17,787	120	1.161	1,879	211	0.264	345
30	3.672	17,284	121	1.143	1,840	212	0.260	339
31	3.644	16,797	122	1.124	1,801	213	0.256	334
32	3.617	16,325	123	1.106	1,764	214	0.252	329
33	3.588	15,868	124	1.088	1,727	215	0.248	323
34	3.559	15,426	125	1.070	1,691	216	0.245	318
35	3.530	14,997	126	1.053	1,656	217	0.241	313
36	3.501	14,582	127	1.036	1,622	218	0.237	308
37	3.471	14,181	128	1.019	1,589	219	0.234	303
38	3.442	13,791	129	1.002	1,556	220	0.230	299
39	3.412	13,415	130	0.986	1,524	221	0.227	294
40	3.382	13,050	131	0.969	1,493	222	0.224	289
41	3.353	12,696	132	0.953	1,463	223	0.220	285
42	3.322	12,353	133	0.938	1,433	224	0.217	280
43	3.291	12,021	134	0.922	1,404	225	0.214	276
44	3.260	11,699	135	0.907	1,376	226	0.211	272
45	3.229	11,386	136	0.893	1,348	227	0.208	267
46	3.198	11,082	137	0.878	1,321	228	0.205	263
47	3.167	10,787	138	0.864	1,295	229	0.203	259
48	3.135	10,500	139	0.849	1,269	230	0.198	255
49	3.104	10,221	140	0.835	1,244	231	0.195	251
50	3.074	9,949	141	0.821	1,219	232	0.192	248
51	3.042	9,689	142	0.808	1,195	233	0.190	244
52	3.010	9,436	143	0.795	1,172	234	0.187	240
53	2.978	9,190	144	0.782	1,149	235	0.184	236
54	2.946	8,951	145	0.769	1,126	236	0.182	233
55	2.914	8,719	146	0.756	1,104	237	0.179	229
56	2.882	8,494	147	0.744	1,083	238	0.176	226
57	2.850	8,275	148	0.731	1,062	239	0.174	223
58	2.819	8,062	149	0.719	1,041	240	0.172	219
59	2.788	7,855	150	0.707	1,021	241	0.169	216
60	2.756	7,655	151	0.696	1,002	242	0.167	213
61	2.724	7,460	152	0.684	983	243	0.164	210
62	2.692	7,271	153	0.673	964	244	0.162	207
63	2.660	7,088	154	0.662	945	245	0.160	204
64	2.628	6,909	155	0.651	928	246	0.158	201
65	2.596	6,736	156	0.640	910	247	0.155	198
						248	0.153	195

Table 14 — Thermistor Temperature (C) vs. Resistance/Voltage Drop

TEMPERATURE (C)	PIC VOLTAGE DROP (V)	RESISTANCE (OHMS)	TEMPERATURE (C)	PIC VOLTAGE DROP (V)	RESISTANCE (OHMS)
-33	4.722	105 616	44	1.338	2 272
-32	4.706	99 640	45	1.300	2 184
-31	4.688	93 928	46	1.263	2 101
-30	4.670	88 480	47	1.227	2 021
-29	4.650	83 297	48	1.192	1 944
-28	4.630	78 377	49	1.158	1 871
-27	4.608	73 722	50	1.124	1 801
-26	4.586	69 332	51	1.091	1 734
-25	4.562	65 205	52	1.060	1 670
-24	4.538	61 343	53	1.029	1 609
-23	4.512	57 745	54	0.999	1 550
-22	4.486	54 411	55	0.969	1 493
-21	4.458	51 341	56	0.941	1 439
-20	4.429	48 536	57	0.913	1 387
-19	4.399	45 819	58	0.887	1 337
-18	4.368	43 263	59	0.861	1 290
-17	4.336	40 858	60	0.835	1 244
-16	4.303	38 598	61	0.811	1 200
-15	4.269	36 476	62	0.787	1 158
-14	4.233	34 484	63	0.764	1 117
-13	4.196	32 613	64	0.741	1 079
-12	4.158	30 858	65	0.719	1 041
-11	4.119	29 211	66	0.698	1 006
-10	4.079	27 663	67	0.677	971
-9	4.037	26 208	68	0.657	938
-8	3.994	24 838	69	0.638	906
-7	3.951	23 545	70	0.619	876
-6	3.906	22 323	71	0.601	846
-5	3.861	21 163	72	0.583	818
-4	3.814	20 083	73	0.566	791
-3	3.765	19 062	74	0.549	765
-2	3.716	18 097	75	0.533	740
-1	3.667	17 185	76	0.518	715
0	3.617	16 325	77	0.503	692
1	3.565	15 513	78	0.488	670
2	3.512	14 747	79	0.474	648
3	3.459	14 023	80	0.460	628
4	3.406	13 341	81	0.447	608
5	3.353	12 696	82	0.434	588
6	3.298	12 087	83	0.422	570
7	3.242	11 510	84	0.410	552
8	3.185	10 963	85	0.398	535
9	3.129	10 444	86	0.387	518
10	3.074	9 949	87	0.376	502
11	3.016	9 486	88	0.365	487
12	2.959	9 046	89	0.355	472
13	2.901	8 628	90	0.344	458
14	2.844	8 232	91	0.335	444
15	2.788	7 855	92	0.325	431
16	2.730	7 499	93	0.316	418
17	2.672	7 160	94	0.308	405
18	2.615	6 839	95	0.299	393
19	2.559	6 535	96	0.291	382
20	2.503	6 246	97	0.283	371
21	2.447	5 972	98	0.275	360
22	2.391	5 711	99	0.267	349
23	2.335	5 463	100	0.260	339
24	2.280	5 226	101	0.253	330
25	2.227	5 000	102	0.246	320
26	2.173	4 787	103	0.239	311
27	2.120	4 583	104	0.233	302
28	2.067	4 389	105	0.227	294
29	2.015	4 204	106	0.221	286
30	1.965	4 028	107	0.215	278
31	1.914	3 861	108	0.210	270
32	1.865	3 701	109	0.205	262
33	1.816	3 549	110	0.198	255
34	1.768	3 404	111	0.193	248
35	1.721	3 266	112	0.188	242
36	1.675	3 134	113	0.183	235
37	1.629	3 008	114	0.178	229
38	1.585	2 888	115	0.174	223
39	1.542	2 773	116	0.170	217
40	1.499	2 663	117	0.165	211
41	1.457	2 559	118	0.161	205
42	1.417	2 459	119	0.157	200
43	1.377	2 363	120	0.153	195

CHECK SENSOR ACCURACY

Place the sensor in a medium of known temperature and compare that temperature to the measured reading. The thermometer used to determine the temperature of the medium should be of laboratory quality with 0.5°F (0.25°C) graduations. The sensor in question should be accurate to within 2°F (1.2°C).

Note that the PIC 6 control module, MAINTENANCE menu, offers a water temperature sensor calibration feature where the sensor temperature can be offset. To use this feature, place the sensor at 32°F (0°C) or other known temperature. Read the raw temperature and calculate offset based on the reading seen in the TEMP_CAL menu. Enter and execute the offset, which cannot exceed ± 2°F (1.2°C).

See Fig. 3-5 for sensor locations. The sensors are immersed directly in the refrigerant or water circuits. When installing a new

sensor, apply a pipe sealant or thread sealant to the sensor threads.

An additional thermistor, factory installed in the bottom of the cooler barrel, is displayed as Evap Refrig Liquid Temp on the TEMPERATURES display screen. This thermistor provides additional protection against a loss of water flow.

DUAL TEMPERATURE SENSORS

For servicing convenience, there are 2 redundant sensors each on the bearing and motor temperature sensors. If one of the sensors is damaged, the other can be used by simply moving a wire. The number 2 terminal in the sensor terminal box is the common line. To use the second sensor, move the wire from the number 1 position to the number 3 position. See Fig. 48-50.

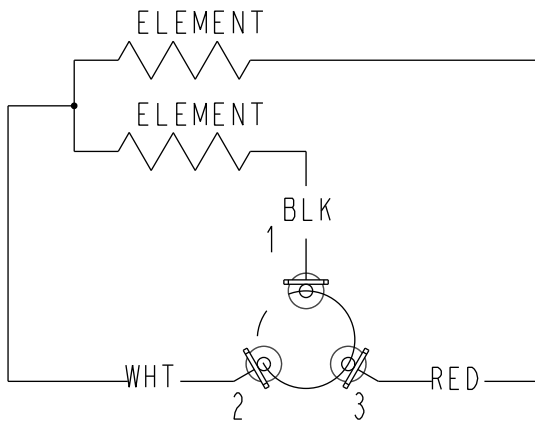
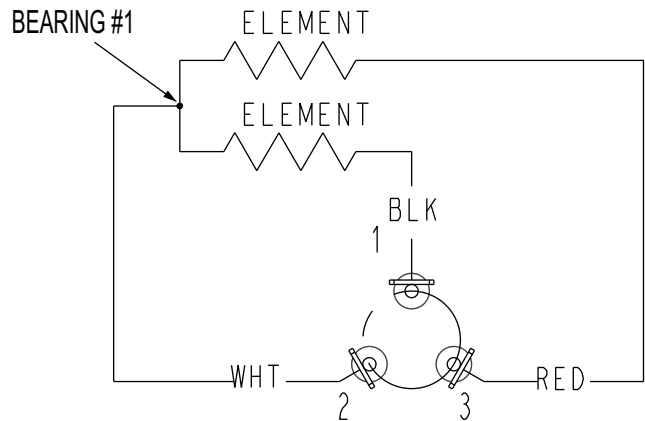
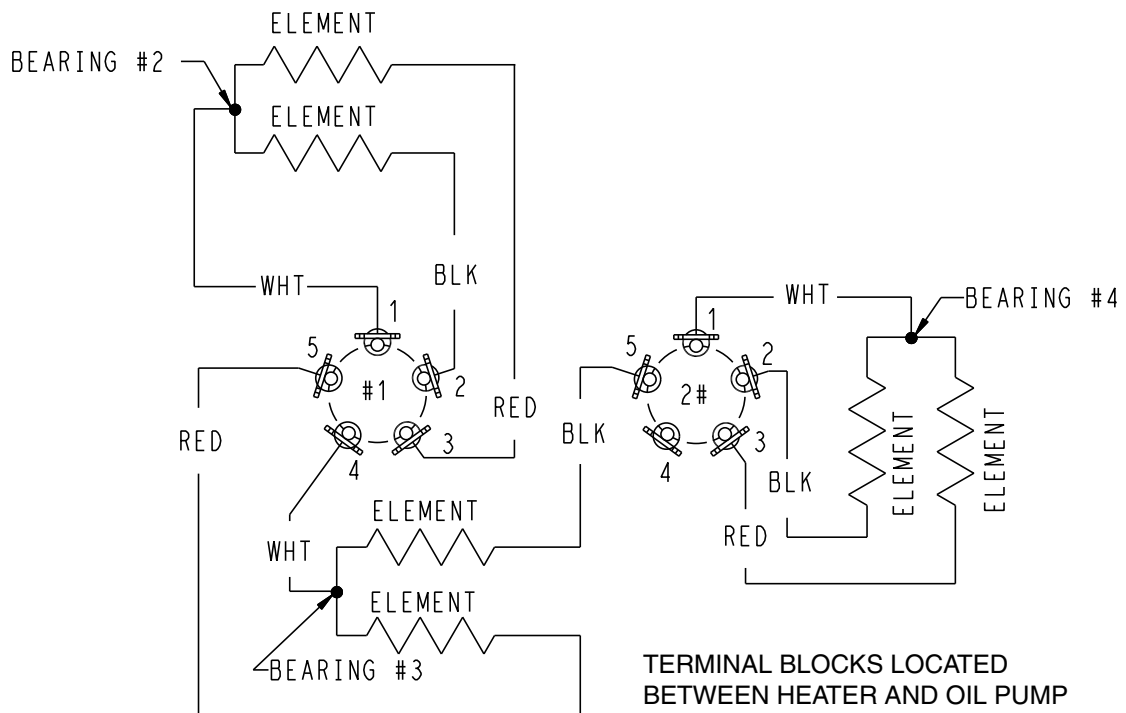

Fig. 48 — 19XR2-E Thrust-Bearing Sensor



TERMINAL BLOCK LOCATED ON END OF MOTOR COVER

Fig. 49 — Bearing 1 Sensor Wiring from Back of Terminal Block (XR6/7 only)



TERMINAL BLOCKS LOCATED BETWEEN HEATER AND OIL PUMP

Fig. 50 — Bearings 2-4 Sensor Wiring from Back of Terminal Block (XR6/7 only)

Checking Pressure Transducers

There are 4 typically factory-installed pressure transducers measuring refrigerant and oil pressure and, if equipped, a fifth pressure transducer measuring economizer pressure.

These transducers can be calibrated if necessary. It is necessary to calibrate at initial start-up, particularly at high altitude locations, to ensure the proper refrigerant temperature/pressure relationship. Each transducer is supplied with 5 vdc power. If the power supply fails, a transducer voltage reference alarm occurs. If the transducer reading is suspected of being faulty, check the TRANSDUCER VOLTAGE REF supply voltage. It should be $5 \text{ vdc} \pm 0.5 \text{ v}$ as displayed in **MAINTENANCE MENU** → **MAINTENANCE OTHERS**, where all the transducer voltages are shown. If the TRANSDUCER VOLTAGE REF supply voltage is correct, the transducer should be recalibrated or replaced.

Also check that inputs have not been grounded.

PRESSURE TRANSDUCER REPLACEMENT

Since the transducers are mounted on Schrader-type fittings, there is no need to remove refrigerant from the vessel when replacing the transducers. Disconnect the transducer wiring. *Do not pull on the transducer wires.* Unscrew the transducer from the Schrader fitting. When installing a new transducer, do not use pipe sealer (which can plug the sensor). Put the plug connector back on the sensor and snap into place. Check for refrigerant leaks.

WARNING

Be sure to use a back-up wrench on the Schrader fitting whenever removing a transducer, since the Schrader fitting may back out with the transducer, causing a large leak and possible injury to personnel.

COOLER AND CONDENSER PRESSURE TRANSDUCER CALIBRATION

Calibration can be checked by comparing the pressure readings from the transducer to an accurate refrigeration gage reading. These readings can be viewed or calibrated from the HMI screen. The transducer can be checked and calibrated at 2 pressure points. These calibration points are 0 psig (0 kPa) and between 25 and 250 psig (173 and 1724 kPa). Wiring is shown in Fig. 51. Installation of pressure transducers into water nozzles using flushable dirt leg trap is suggested; see Fig. 52. Connect pressure transducer to Schrader connection. To enable this option, IOB4 must be activated and the Option must be selected in the Option Configuration menu. To calibrate these transducers:

1. Shut down the compressor, cooler, and condenser pumps.
NOTE: There should be no flow through the heat exchangers.
2. Disconnect the transducer in question from its Schrader fitting for cooler or condenser transducer calibration. For oil pressure or flow device calibration, leave the transducer in place.
NOTE: If the cooler or condenser vessels are at 0 psig (0 kPa) or are open to atmospheric pressure, the transducers can be calibrated for zero without removing the transducer from the vessel.
3. Access the **PRESSURE** or **HYDRAULIC STATUS** screen and view the particular transducer reading. To calibrate oil pressure or waterside flow device, view the particular reading. It should read 0 psig (0 kPa). If the reading is not 0 psig (0 kPa), but within ± 5 psig (35 kPa), the value may be set to zero from the Maintenance Menu while the appropriate transducer parameter is highlighted. The value will now go to zero.
If the transducer value is not within the calibration range, the transducer returns to the original reading. If the pressure is within the allowed range (noted above), check the voltage

ratio of the transducer. To obtain the voltage ratio, divide the voltage (dc) input from the transducer by the supply voltage signal or measure across the positive (+ red) and negative (– black) leads of the transducer. The input to reference voltage ratio must be between 0.80 and 0.11 for the software to allow calibration. Rotate the waterside flow pressure device from the inlet nozzle to the outlet nozzle and repeat this step. If rotating the waterside flow device does not allow calibration, pressurize the transducer until the ratio is within range. Then attempt calibration again.

4. Pressures can be calibrated between 100 and 250 psig (689.5 and 1723.7 kPa) by attaching a regulated 250 psig (1724 kPa) pressure (usually from a nitrogen cylinder). For calibration, access the Pressure Sensor Calibration Menu from the Maintenance Menu and calibrate the appropriate sensor.

The PIC 6 control system does not allow calibration if the transducer is too far out of calibration. In this case, a new transducer must be installed and re-calibrated. If calibration problems are encountered on the OIL PRESSURE DELTA P channel, sometimes swapping the compressor oil discharge pressure transducer and the oil sump pressure transducer will offset an adverse transducer tolerance stack up and allow the calibration to proceed.

HYDRAULIC STATUS

The HYDRAULIC STATUS screen (access from the Main Menu) provides a convenient way to detect if any of the cooler/condenser pressure switches (if installed) are in need of calibration. With no flow and no added resistors the water delta should read zero psig (0 kPa). If it does not, the value may be set to zero using **PRESSURE SENSOR CALIB** located in the Maintenance Menu.

High Altitude Locations

Because the chiller is initially calibrated at sea level, it is necessary to recalibrate the pressure transducers if the chiller has been moved to a high altitude location. See the calibration procedure in the 19XR with PIC 6 Controls Operation and Troubleshooting guide. Note that Atmospheric Pressure can be adjusted in the Service Parameters Menu (located in the Configuration Menu).

Quick Test

The Quick Test feature is located in the Main Menu. Use this feature to test guide vanes, test chiller status, test the status of various actuators, view water temperature deltas, and test oil pump and oil heater relays, as well as control inlet guide vane, hot gas bypass, economizer damper, alarms, condenser, and chilled water pumps. The tests can help to determine whether a switch is defective or a pump relay is not operating, as well as other useful troubleshooting issues. During pumpdown operations, the pumps are energized to prevent freeze-up and the vessel pressures and temperatures are displayed. Note that prior to Quick Test, components with feedback needs to be calibrated in Quick Calibration.

Pumpdown/Lockout

The Pumpdown/Lockout feature, available from the Maintenance Menu, prevents compressor start-up when there is no refrigerant in the chiller or if the vessels are isolated. The Terminate Lockout feature ends the Pumpdown/Lockout after the pumpdown procedure is reversed and refrigerant is added.

Physical Data

Tables 15-45 and Fig. 53-69 provide additional information on component weights, compressor fits and clearances, physical and electrical data, and wiring schematics for the operator's convenience during troubleshooting.

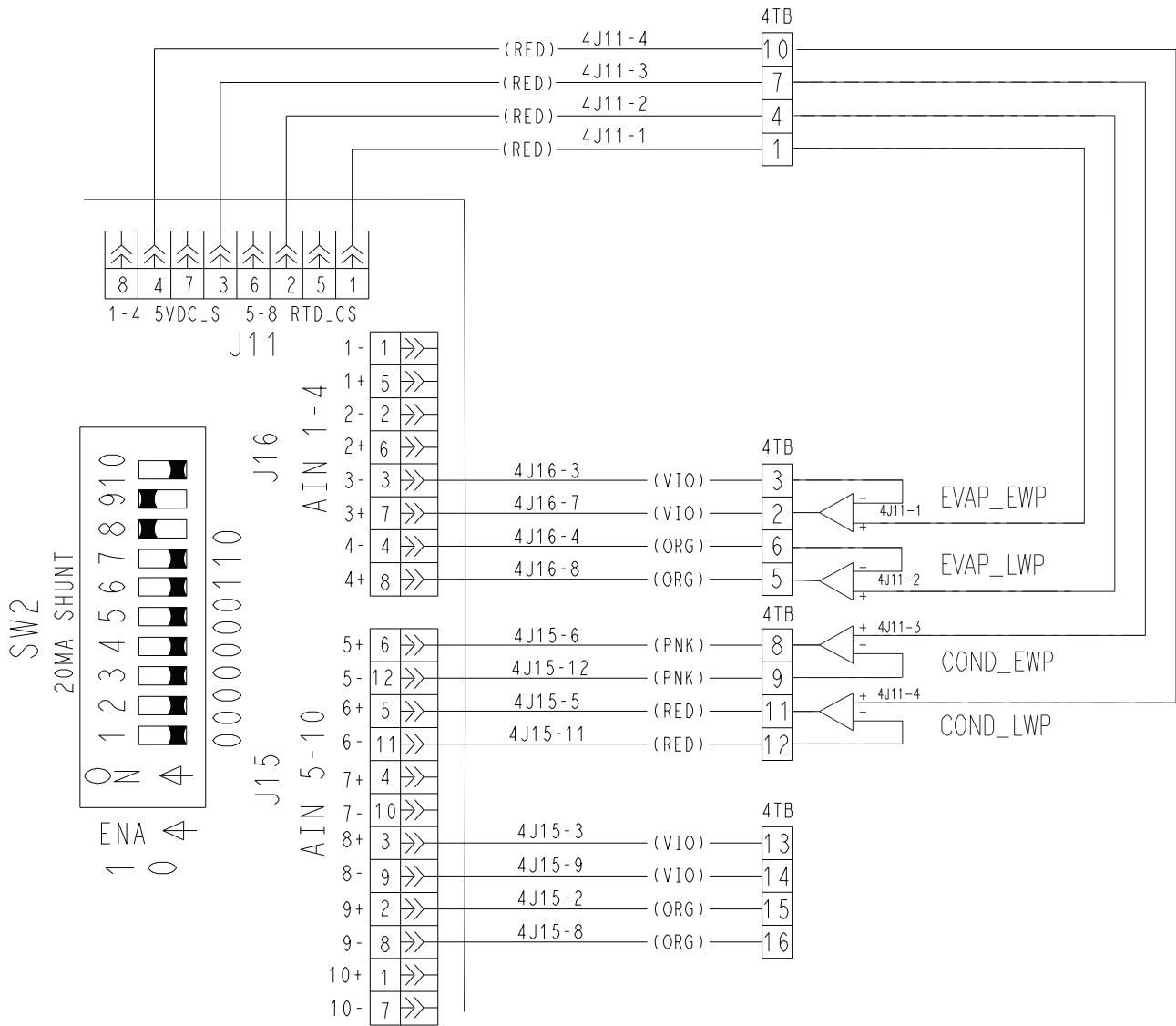

Fig. 51 — Inputs for Optional Waterside Delta P Transducers for IOB4

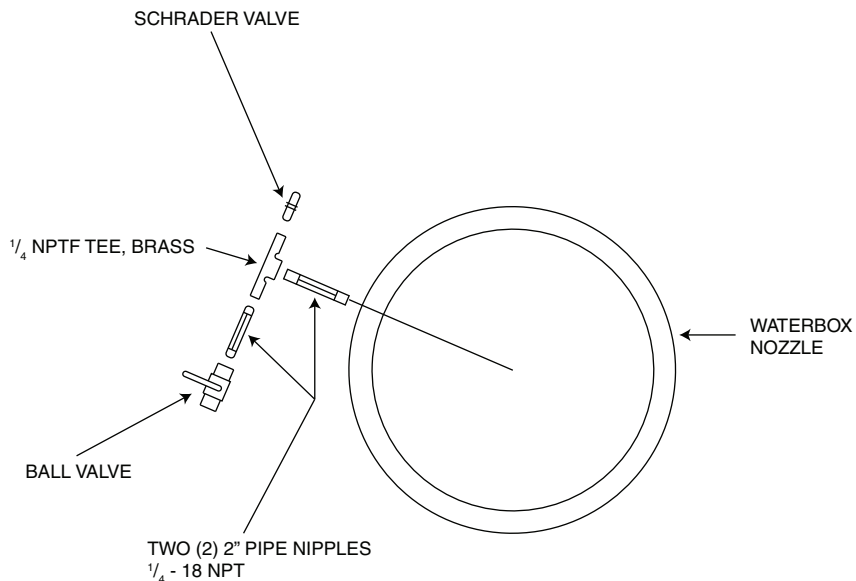

Fig. 52 — Suggested Installation of Pressure Transducers into Water Nozzles Using Flushable Dirt Leg Trap

Table 15 — 19XR Heat Exchanger Weights

CODE †	ENGLISH						SI					
	Dry Rigging Weight (lb) *		Machine Charge				Dry Rigging Weight (kg) *		Machine Charge			
	Evaporator Only	Condenser Only	Refrigerant Weight (lb)		Water Weight (lb)		Evaporator Only	Condenser Only	Refrigerant Weight (kg)		Water Weight (kg)	
			Evaporator	Condenser	Evaporator	Condenser			Evaporator	Condenser	Evaporator	Condenser
20	3407	3373	416	252	402	398	1547	1531	189	114	183	181
21	3555	3540	459	252	456	462	1614	1607	208	114	207	210
22	3711	3704	505	252	514	526	1685	1682	229	114	233	239
30	4071	3694	510	308	464	464	1848	1677	232	140	211	211
31	4253	3899	565	308	531	543	1931	1770	257	140	241	247
32	4445	4100	626	308	601	621	2018	1861	284	140	273	282
35	4343	4606	577	349	511	513	1972	2091	262	158	232	233
36	4551	4840	639	349	587	603	2066	2197	290	158	266	274
37	4769	5069	709	349	667	692	2165	2301	322	158	303	314
40	4908	5039	726	338	863	915	2228	2288	330	153	392	415
41	5078	5232	783	338	930	995	2305	2375	355	153	422	452
42	5226	5424	840	338	990	1074	2373	2462	381	153	449	488
45	5363	5602	821	383	938	998	2435	2543	373	174	426	453
46	5559	5824	874	383	1014	1088	2524	2644	397	174	460	494
47	5730	6044	949	383	1083	1179	2601	2744	431	174	492	535
50	5713	6090	897	446	1101	1225	2594	2765	407	202	500	556
51	5940	6283	974	446	1192	1304	2697	2852	442	202	541	592
52	6083	6464	1021	446	1248	1379	2762	2935	464	202	567	626
53	6141	6529	1010	446	1277	1409	2788	2964	459	202	580	640
54	6192	6591	987	446	1302	1439	2811	2992	448	202	591	653
55	6257	6785	1014	504	1201	1339	2841	3080	460	229	545	608
56	6517	7007	1101	504	1304	1429	2959	3181	500	229	592	649
57	6682	7215	1154	504	1369	1514	3034	3276	524	229	622	687
58	6751	7291	1143	504	1401	1550	3065	3310	519	229	636	704
59	6811	7363	1116	504	1430	1583	3092	3343	507	229	649	719
5A	5124	—	491	—	1023	—	2326	—	223	—	464	—
5B	5177	—	510	—	1050	—	2350	—	232	—	477	—
5C	5243	—	532	—	1079	—	2380	—	242	—	490	—
5F	5577	—	553	—	1113	—	2532	—	251	—	505	—
5G	5640	—	575	—	1143	—	2561	—	261	—	519	—
5H	5716	—	600	—	1176	—	2595	—	272	—	534	—
5K	4993	—	673	—	1067	—	2267	—	306	—	484	—
5L	5090	—	706	—	1118	—	2311	—	321	—	508	—
5M	5165	—	742	—	1162	—	2345	—	337	—	528	—
5P	5041	—	641	—	1111	—	2289	—	291	—	504	—
5Q	5131	—	678	—	1155	—	2329	—	308	—	524	—
5R	5214	—	709	—	1206	—	2367	—	322	—	548	—
5T	5425	—	768	—	1162	—	2463	—	349	—	528	—
5U	5534	—	801	—	1220	—	2512	—	364	—	554	—
5V	5620	—	843	—	1270	—	2551	—	383	—	577	—
5X	5484	—	730	—	1212	—	2490	—	331	—	550	—
5Y	5584	—	769	—	1262	—	2535	—	349	—	573	—
5Z	5678	—	805	—	1320	—	2578	—	365	—	599	—
60	6719	6764	1091	479	1400	1521	3050	3071	495	217	636	691
61	6895	6949	1150	479	1470	1597	3130	3155	522	217	667	725
62	7038	7130	1202	479	1527	1671	3195	3237	546	217	693	759
63	7103	7199	1202	479	1559	1704	3225	3268	546	217	708	774
64	7161	7264	1178	479	1587	1735	3251	3298	535	217	720	788
65	7392	6782	1241	542	1530	1667	3356	3079	563	246	695	757
66	7594	7894	1309	542	1610	1753	3448	3584	594	246	731	796
67	7759	8102	1369	542	1674	1838	3523	3678	622	246	760	834
68	7836	8182	1359	542	1711	1875	3558	3715	617	246	777	851
69	7905	8258	1332	542	1743	1911	3589	3749	605	246	791	868
6K	5,716	—	760	—	1291	—	2595	—	345	—	586	—
6L	5,804	—	797	—	1341	—	2635	—	362	—	609	—
6M	5,894	—	828	—	1399	—	2676	—	376	—	635	—
6P	5,768	—	725	—	1338	—	2619	—	329	—	607	—
6Q	5,852	—	764	—	1385	—	2657	—	347	—	629	—
6R	5,938	—	798	—	1439	—	2696	—	362	—	653	—
6T	6,230	—	863	—	1405	—	2828	—	392	—	638	—
6U	6,330	—	905	—	1462	—	2874	—	411	—	664	—
6V	6,433	—	941	—	1528	—	2921	—	427	—	694	—
6X	6,293	—	823	—	1459	—	2857	—	374	—	662	—
6Y	6,388	—	868	—	1512	—	2900	—	394	—	686	—
6Z	6,487	—	906	—	1574	—	2945	—	411	—	715	—
70	9,942	10,786	1409	840	2008	2225	4514	4897	640	381	912	1010
71	10,330	11,211	1539	840	2164	2389	4690	5090	699	381	982	1085
72	10,632	11,622	1646	840	2286	2548	4827	5276	747	381	1038	1157
73	10,715	11,737	1622	840	2328	2604	4865	5329	736	381	1057	1182

Table 15 — 19XR Heat Exchanger Weights (cont)

CODE †	ENGLISH						SI					
	Dry Rigging Weight (lb) *		Machine Charge				Dry Rigging Weight (kg) *		Machine Charge			
	Evaporator Only	Condenser Only	Refrigerant Weight (lb)		Water Weight (lb)		Evaporator Only	Condenser Only	Refrigerant Weight (kg)		Water Weight (kg)	
			Evaporator	Condenser	Evaporator	Condenser			Evaporator	Condenser	Evaporator	Condenser
74	10,790	11,775	1584	840	2366	2622	4899	5346	719	381	1074	1190
75	10,840	11,859	1599	950	2183	2431	4921	5384	726	431	991	1104
76	11,289	12,345	1747	950	2361	2619	5125	5605	793	431	1072	1189
77	11,638	12,814	1869	950	2501	2801	5284	5818	849	431	1135	1272
78	11,738	12,949	1849	950	2548	2864	5329	5879	839	431	1157	1300
79	11,828	12,994	1806	950	2592	2885	5370	5899	820	431	1177	1310
7K	8,728	—	1047	—	1948	—	3963	—	475	—	884	—
7L	8,959	—	1132	—	2094	—	4067	—	514	—	951	—
7M	9,161	—	1214	—	2229	—	4159	—	551	—	1012	—
7P	8,792	—	1002	—	2010	—	3992	—	455	—	913	—
7Q	9,023	—	1087	—	2156	—	4096	—	493	—	979	—
7R	9,229	—	1167	—	2295	—	4190	—	530	—	1042	—
7T	9,431	—	1194	—	2115	—	4282	—	542	—	960	—
7U	9,698	—	1292	—	2282	—	4403	—	587	—	1036	—
7V	9,932	—	1403	—	2436	—	4509	—	637	—	1106	—
7X	9,510	—	1142	—	2185	—	4318	—	518	—	992	—
7Y	9,777	—	1240	—	2352	—	4439	—	563	—	1068	—
7Z	10,016	—	1347	—	2511	—	4547	—	612	—	1140	—
80	12,664	12,753	1700	836	2726	2977	5749	5790	772	380	1238	1352
81	12,998	13,149	1812	836	2863	3143	5901	5970	823	380	1300	1427
82	13,347	13,545	1928	836	3005	3309	6060	6149	875	380	1364	1502
83	13,437	13,872	1877	836	3053	3476	6100	6298	852	380	1386	1578
84	13,523	14,217	1840	836	3099	3651	6139	6455	835	380	1407	1658
85	13,804	14,008	1927	945	2951	3238	6267	6360	875	429	1340	1470
86	14,191	14,465	2054	945	3108	3428	6443	6567	933	429	1411	1556
87	14,597	14,923	2186	945	3271	3618	6627	6775	992	429	1485	1643
88	14,705	15,311	2142	945	3325	3608	6676	6951	972	429	1510	1638
89	14,808	15,721	2099	945	3378	4009	6723	7137	953	429	1534	1820
8K	11,153	—	1385	—	2760	—	5063	—	629	—	1253	—
8L	11,400	—	1484	—	2926	—	5176	—	674	—	1328	—
8M	11,650	—	1589	—	3088	—	5289	—	721	—	1402	—
8P	11,219	—	1334	—	2830	—	5093	—	606	—	1285	—
8Q	11,470	—	1430	—	2999	—	5207	—	649	—	1362	—
8R	11,719	—	1535	—	3161	—	5320	—	697	—	1435	—
8T	12,069	—	1580	—	2991	—	5479	—	717	—	1358	—
8U	12,357	—	1694	—	3180	—	5610	—	769	—	1444	—
8V	12,645	—	1814	—	3365	—	5741	—	824	—	1528	—
8X	12,152	—	1522	—	3070	—	5517	—	691	—	1394	—
8Y	12,444	—	1632	—	3264	—	5650	—	741	—	1482	—
8Z	12,733	—	1752	—	3448	—	5781	—	795	—	1565	—
A40	16,877	18,542	1647	927	4328	4553	7655	8 410	747	420	1963	2065
A41	17,270	19,062	1773	927	4557	4890	7833	8 646	804	420	2067	2218
A42	17,690	19,565	1887	927	4816	5213	8024	8 875	856	420	2184	2365
A45	16,968	18,493	1599	927	4453	4582	7697	8 388	725	420	2020	2078
A46	17,371	19,063	1714	927	4701	4949	7879	8 647	777	420	2132	2245
A47	17,761	19,578	1837	927	4941	5281	8056	8 880	833	420	2241	2395
A60	18,354	20,139	1878	1074	4721	5029	8325	9 135	852	487	2141	2281
A61	18,807	20,745	2022	1074	4984	5415	8531	9 410	917	487	2261	2456
A62	19,295	21,330	2152	1074	5280	5786	8752	9 675	976	487	2395	2624
A65	18,469	20,095	1823	1074	4859	5060	8377	9 115	827	487	2204	2295
A66	18,936	20,758	1954	1074	5144	5482	8589	9 416	886	487	2333	2487
A67	19,389	21,357	2095	1074	5419	5862	8795	9 687	950	487	2458	2659
A4A	15,540	17,089	1681	861	4183	4524	7049	7 751	762	391	1897	2052
A4B	15,794	17,472	1792	861	4392	4859	7164	7 925	813	391	1992	2204
A4C	16,063	17,812	1897	861	4615	5137	7286	8 079	860	391	2093	2330
A4F	15,592	17,076	1626	861	4322	4588	7072	7 746	738	391	1960	2081
A4G	15,845	17,405	1736	861	4531	4867	7187	7 895	787	391	2055	2208
A4H	16,249	17,821	1890	861	4865	5219	7370	8 083	857	391	2207	2367
A6A	16,465	18,359	1917	998	4555	4996	7468	8 328	870	453	2066	2266
A6B	16,758	18,806	2044	998	4794	5368	7601	8 530	927	453	2175	2435
A6C	17,070	19,202	2164	998	5050	5698	7743	8 710	982	453	2291	2585
A6F	16,535	18,356	1854	998	4709	5068	7500	8 326	841	453	2136	2299
A6G	16,829	18,739	1979	998	4948	5387	7633	8 500	898	453	2244	2444
A6H	17,296	19,225	2156	998	5331	6156	7845	8 730	978	453	2418	2792
B40	—	21,217	—	1233	—	5850	—	9 624	—	559	—	2653
B41	—	21,965	—	1233	—	6333	—	9 963	—	559	—	2873
B42	—	22,581	—	1233	—	6729	—	10 243	—	559	—	3052
B45	—	21,173	—	1233	—	5904	—	9 604	—	559	—	2678
B46	—	21,909	—	1233	—	6379	—	9 938	—	559	—	2893
B47	—	22,653	—	1233	—	6859	—	10 275	—	559	—	3111

Table 15 — 19XR Heat Exchanger Weights (cont)

CODE †	ENGLISH						SI					
	Dry Rigging Weight (lb) *		Machine Charge				Dry Rigging Weight (kg) *		Machine Charge			
	Evaporator Only	Condenser Only	Refrigerant Weight (lb)		Water Weight (lb)		Evaporator Only	Condenser Only	Refrigerant Weight (kg)		Water Weight (kg)	
			Evaporator	Condenser	Evaporator	Condenser			Evaporator	Condenser	Evaporator	Condenser
B60	—	23,061	—	1423	—	6464	—	10 460	—	645	—	2932
B61	—	23,932	—	1423	—	7018	—	10 855	—	645	—	3183
B62	—	24,649	—	1423	—	7473	—	11 181	—	645	—	3390
B65	—	23,022	—	1423	—	6521	—	10 442	—	645	—	2958
B66	—	23,879	—	1423	—	7066	—	10 831	—	645	—	3205
B67	—	24,745	—	1423	—	7617	—	11 224	—	645	—	3455
B4A	—	19,217	—	1148	—	5756	—	8 717	—	521	—	2611
B4B	—	19,793	—	1148	—	6243	—	8 978	—	521	—	2832
B4C	—	20,254	—	1148	—	6633	—	9 187	—	521	—	3009
B4F	—	19,217	—	1148	—	5852	—	8 717	—	521	—	2654
B4G	—	19,721	—	1148	—	6279	—	8 945	—	521	—	2848
B4H	—	20,318	—	1148	—	6785	—	9 216	—	521	—	3078
B6A	—	20,794	—	1326	—	6357	—	9 432	—	601	—	2883
B6B	—	21,465	—	1326	—	6915	—	9 736	—	601	—	3137
B6C	—	22,002	—	1326	—	7362	—	9 980	—	601	—	3339
B6F	—	20,806	—	1326	—	6462	—	9 487	—	601	—	2931
B6G	—	21,393	—	1326	—	6951	—	9 704	—	601	—	3153
B6H	—	22,088	—	1326	—	8379	—	10 019	—	601	—	3801
B60	24,704	—	2273	—	6,340	—	11 206	—	1031	—	2876	—
B61	25,337	—	2355	—	6,737	—	11 493	—	1068	—	3056	—
B62	25,964	—	2460	—	7,116	—	11 777	—	1116	—	3228	—
B65	25,014	—	2185	—	6,485	—	11 346	—	991	—	2941	—
B66	25,631	—	2275	—	6,873	—	11 626	—	1032	—	3118	—
B67	26,264	—	2379	—	7,255	—	11 913	—	1079	—	3291	—
B6A	22,819	—	2081	—	6,159	—	10 351	—	944	—	2794	—
B6B	23,299	—	2162	—	6,568	—	10 568	—	981	—	2979	—
B6C	23,829	—	2256	—	6,993	—	10 809	—	1023	—	3172	—
B6G	23,648	—	2019	—	6,774	—	10 727	—	916	—	3073	—
B6H	24,171	—	2120	—	7,194	—	10 964	—	962	—	3263	—
B80	26,184	—	2557	—	6,766	—	11 877	—	1160	—	3069	—
B81	26,922	—	2649	—	7,208	—	12 212	—	1202	—	3269	—
B82	27,627	—	2768	—	7,629	—	12 531	—	1256	—	3460	—
B85	26,438	—	2458	—	6,923	—	11 992	—	1115	—	3141	—
B86	27,157	—	2559	—	7,355	—	12 318	—	1161	—	3336	—
B87	27,868	—	2676	—	7,780	—	11 214	—	1214	—	3529	—
B8A	24,164	—	2341	—	6,580	—	10 952	—	1062	—	2885	—
B8B	24,722	—	2432	—	7,036	—	11 214	—	1103	—	3191	—
B8C	25,317	—	2538	—	7,510	—	11 484	—	1151	—	3406	—
B8F	24,403	—	2195	—	6,783	—	11 069	—	996	—	3077	—
B8G	25,011	—	2271	—	7,262	—	11 345	—	1030	—	3294	—
B8H	25,599	—	2385	—	7,731	—	11 612	—	1082	—	3507	—
C60	30,825	29,857	2647	1610	8,475	8,630	13 982	13 543	1201	730	3841	3914
C61	31,536	30,881	2751	1610	8,924	9,275	14 304	14 007	1248	730	4048	4207
C62	32,467	31,871	2875	1610	9,474	9,916	14 727	14 456	1304	730	4297	4498
C65	31,135	29,982	2562	1610	8,645	8,684	14 123	13 600	1162	730	3921	3939
C66	31,851	31,064	2666	1610	9,097	9,362	14 447	14 090	1209	730	4126	4247
C67	32,777	32,186	2793	1610	9,644	10,078	14 867	14 599	1267	730	4374	4571
C6A	28,641	27,676	2443	1497	6,898	6,675	12 991	12 554	1108	679	3129	3935
C6B	29,167	28,315	2534	1497	7,352	9,216	13 230	12 843	1149	679	3325	4180
C6C	29,750	28,918	2627	1497	7,823	9,752	13 494	13 117	1192	679	3553	4423
C6F	28,929	27,774	2334	1497	7,724	8,710	13 222	12 508	1059	679	3504	3951
C6G	29,478	28,457	2415	1497	8,194	9,283	13 371	12 908	1095	679	3717	4211
C6H	30,083	29,223	2500	1497	8,681	9,935	13 645	13 255	1134	679	3938	4506
C80	22,433	31,810	2978	1811	9,084	9,312	10 175	14 429	1351	821	4120	4224
C81	22,315	32,955	3095	1811	9,589	10,029	10 122	14 948	1404	821	4349	4549
C82	22,231	34,094	3234	1811	10,208	10,742	10 084	15 465	1467	821	4630	4872
C85	22,534	31,911	2882	1811	9,275	9,367	10 221	14 475	1307	821	4207	4249
C86	22,416	33,113	2999	1811	9,784	10,120	10 168	14 020	1360	821	4438	4590
C87	22,332	34,385	3142	1811	10,399	10,196	10 130	15 597	1425	821	4717	4625
C8A	22,432	19,664	2748	1684	7,310	9,387	10 175	8 919	1246	764	3316	4258
C8B	22,314	19,548	2851	1684	7,821	9,991	10 121	8 867	1293	764	3548	4532
C8C	22,230	19,463	2955	1684	8,351	10,589	10 083	8 816	1340	764	3788	4803
C8F	22,533	19,763	2626	1684	8,239	9,420	10 221	8 964	1191	764	3737	4273
C8G	22,415	19,641	2717	1684	8,768	10,059	10 167	8 909	1232	764	3977	4563
C8H	22,331	19,503	2813	1684	9,316	10,787	10 129	8 846	1276	764	4226	4893
D60	—	38,296	—	2097	—	11,473	—	17 371	—	951	—	5204
D61	—	39,624	—	2097	—	12,309	—	17 973	—	951	—	5583
D62	—	41,031	—	2097	—	13,210	—	18 611	—	951	—	5992
D65	—	37,624	—	2097	—	11,617	—	17 066	—	951	—	5269
D66	—	38,837	—	2097	—	12,387	—	17 616	—	951	—	5619

Table 15 — 19XR Heat Exchanger Weights (cont)

CODE †	ENGLISH						SI					
	Dry Rigging Weight (lb) *		Machine Charge				Dry Rigging Weight (kg) *		Machine Charge			
	Evaporator Only	Condenser Only	Refrigerant Weight (lb)		Water Weight (lb)		Evaporator Only	Condenser Only	Refrigerant Weight (kg)		Water Weight (kg)	
			Evaporator	Condenser	Evaporator	Condenser			Evaporator	Condenser	Evaporator	Condenser
D67	—	40,460	—	2097	—	13,410	—	18 352	—	951	—	6083
D80	—	41,916	—	2359	—	12,447	—	19 013	—	1070	—	5646
D81	—	43,382	—	2359	—	13,388	—	19 678	—	1070	—	6073
D82	—	44,963	—	2359	—	14,401	—	20 395	—	1070	—	6532
D85	—	42,058	—	2359	—	12,609	—	19 077	—	1070	—	5719
D86	—	43,408	—	2359	—	13,475	—	19 690	—	1070	—	6112
D87	—	45,204	—	2359	—	14,626	—	20 504	—	1070	—	6634
D6A	—	35,286	—	1947	—	11,401	—	16 005	—	883	—	5171
D6B	—	36,328	—	1947	—	12,255	—	16 478	—	883	—	5559
D6C	—	37,288	—	1947	—	13,078	—	16 914	—	883	—	5932
D6F	—	34,447	—	1947	—	11,448	—	15 625	—	883	—	5193
D6G	—	35,637	—	1947	—	12,408	—	16 165	—	883	—	5628
D6H	—	36,663	—	1947	—	13,278	—	16 630	—	883	—	6023
D8A	—	38,494	—	2190	—	12,366	—	17 461	—	993	—	5609
D8B	—	39,633	—	2190	—	13,327	—	17 977	—	993	—	6045
D8C	—	40,731	—	2190	—	14,253	—	18 475	—	993	—	6465
D8F	—	38,479	—	2190	—	12,419	—	17 454	—	993	—	5633
D8G	—	39,761	—	2190	—	13,499	—	18 035	—	993	—	6123
D8H	—	40,922	—	2190	—	14,478	—	18 562	—	993	—	6567

* Rigging weights are for standard tubes of standard wall thickness (0.025-in. [0.635 mm] wall) and do not include refrigerant weight.

† See Model Number Nomenclature.

NOTES:

1. Evaporator weight includes the suction elbow and the distribution piping to the economizer and two-pass Victaulic dished heads.
2. Condenser weight includes the high side float chamber, discharge pipe, and the distribution piping weight from the economizer to the float chamber and two-pass Victaulic dished heads.

Table 16 — Economizer Weight

FRAME SIZE	DRY WEIGHT (lb)*	REFRIGERANT WEIGHT (lb)	OPERATION WEIGHT (lb)	DRY WEIGHT (kg)*	REFRIGERANT WEIGHT (kg)	OPERATION WEIGHT (kg)
XRC (fr 5 HX)	1019	210	1229	462	95	557
XRC (fr 6,7 HX)	1252	250	1502	568	113	681
XRE	1054	283	1337	478	128	606
XR6	1589	360	1949	721	163	884
XR7	2749	646	3395	1247	293	1540

* Includes economizer weight and all connecting piping to compressor.

Table 17 — 19XR Additional Data for Marine Waterboxes (19XR2-E)*

HEAT EXCHANGER FRAME, PASS	ENGLISH				SI					
	PSIG	RIGGING WEIGHT (LB)		WATER VOLUME (GAL)		KPA	RIGGING WEIGHT (KG)		WATER VOLUME (L)	
		COOLER	CONDENSER	COOLER	CONDENSER		COOLER	CONDENSER	COOLER	CONDENSER
FRAME 2, 1 AND 3 PASS	150	730	—	84	—	1034	331	—	318	—
FRAME 2, 2 PASS		365	365	42	42		166	166	159	159
FRAME 3, 1 AND 3 PASS		730	—	84	—		331	—	318	—
FRAME 3, 2 PASS		365	365	42	42		166	166	159	159
FRAME 4, 1 AND 3 PASS		1888	—	109	—		856	—	412	—
FRAME 4, 2 PASS		944	989	54	54		428	449	205	205
FRAME 5, 1 AND 3 PASS		2445	—	122	—		1109	—	462	—
FRAME 5, 2 PASS		1223	1195	61	60		555	542	231	226
FRAME 6, 1 AND 3 PASS		2860	—	139	—		1297	—	524	—
FRAME 6, 2 PASS		1430	1443	69	69		649	655	262	262
FRAME 7, 1 AND 3 PASS		3970	—	309	—		1801	—	1170	—
FRAME 7, 2 PASS		1720	1561	155	123		780	708	585	465
FRAME 8, 1 AND 3 PASS		5048	—	364	—		2290	—	1376	—
FRAME 8, 2 PASS		2182	1751	182	141		990	794	688	532
FRAME 2, 1 AND 3 PASS	300	860	—	84	—	2068	390	—	318	—
FRAME 2, 2 PASS		430	430	42	42		195	195	159	159
FRAME 3, 1 AND 3 PASS		860	—	84	—		390	—	318	—
FRAME 3, 2 PASS		430	430	42	42		195	195	159	159
FRAME 4, 1 AND 3 PASS		2162	—	109	—		981	—	412	—
FRAME 4, 2 PASS		1552	1641	47	47		704	744	178	178
FRAME 5, 1 AND 3 PASS		2655	—	122	—		1204	—	462	—
FRAME 5, 2 PASS		1965	1909	53	50		891	866	199	190
FRAME 6, 1 AND 3 PASS		3330	—	139	—		1510	—	524	—
FRAME 6, 2 PASS		2425	2451	58	58		1100	1112	218	218
FRAME 7, 1 AND 3 PASS		5294	—	309	—		2401	—	1170	—
FRAME 7, 2 PASS		4140	4652	146	94		1878	2110	553	356
FRAME 8, 1 AND 3 PASS		6222	—	364	—		2822	—	1376	—
FRAME 8, 2 PASS		4952	4559	161	94		2246	2068	609	355

* Add to heat exchanger data for total weights or volumes.

NOTE: For the total weight of a vessel with a marine waterbox, add these values to the heat exchanger weights (or volumes).

Table 18 — 19XRV Additional Data for Marine Waterboxes (19XR6/7)*

HEAT EXCHANGER FRAME, PASS	COUPLING TYPE	ENGLISH (lb)				SI (kg)					
		psig	Rigging Weight		Water Weight		kPa	Rigging Weight		Water Weight	
			Cooler	Condenser	Cooler	Condenser		Cooler	Condenser	Cooler	Condenser
SIZE 6, FRAME A, 1 PASS	Victaulic	150	2,794	2,582	6,515	5,648	1034	1267	1171	2955	2562
	Flange		3,124	2,912				1417	1321		
SIZE 6, FRAME A, 2 PASS	Victaulic		2,454	2,236	2,979	2,613		1113	1014	2979	1185
	Flange		2,650	2,432				1202	1103		
SIZE 6, FRAME A, 3 PASS	Victaulic		2,771	2,840	4,190	3,950		1157	1288	1900	1792
	Flange		2,899	3,020				1315	1370		
SIZE 6, FRAME B, 1 PASS	Victaulic		—	2,604	—	6,975		—	1181	—	3162
	Flange		—	2,934				—	1331		
SIZE 6, FRAME B, 2 PASS	Victaulic		—	2,459	—	3,600		—	1115	—	1633
	Flange		—	2,719				—	1233		
SIZE 6, FRAME B, 3 PASS	Victaulic		—	2,770	—	4,858		—	1256	—	2203
	Flange		—	2,950				—	1338		
SIZE 7 FRAME B, 1 PASS	Victaulic		4,045	—	8,103	—		1835	—	3675	—
	Flange		4,375	—				1984	—		
SIZE 7 FRAME B, 2 PASS	Victaulic		3,648	—	4,139	—		1655	—	1877	—
	Flange		3,908	—				1773	—		
SIZE 7 FRAME B, 3 PASS	Victaulic		4,160	—	5,633	—		1887	—	2555	—
	Flange		4,340	—				1969	—		
SIZE 7 FRAME C, 1 PASS	Victaulic		4,828	4,273	10,264	9,858		2190	1938	4655	4472
	Flange		5,158	4,713				2340	2138		
SIZE 7 FRAME C, 2 PASS	Victaulic		4,375	3,714	5,201	4,826		1984	1685	2359	2189
	Flange		4,635	4,044				2102	1834		
SIZE 7 FRAME C, 3 PASS	Victaulic		4,957	4,434	7,144	6,819		2248	2011	3240	3093
	Flange		5,137	4,630				2330	2100		
SIZE 7 FRAME D, 1 PASS	Victaulic	—	4,863	—	12,530	—	2206	—	5684		
	Flange	—	5,303			—	2405				
SIZE 7 FRAME D, 2 PASS	Victaulic	—	4,243	—	6,074	—	1925	—	2755		
	Flange	—	4,573			—	2074				
SIZE 7 FRAME D, 3 PASS	Victaulic	—	5,079	—	8,659	—	2303	—	3928		
	Flange	—	5,275			—	2393				
SIZE 6, FRAME A, 1 PASS	Victaulic	300	2,794	2,582	6,515	5,648	2068	1171	—	2955	2562
	Flange		3,124	2,912				1417	1321		
SIZE 6, FRAME A, 2 PASS	Victaulic		2,454	2,236	2,979	2,613		1113	1014	2979	1185
	Flange		2,650	2,432				1202	1103		
SIZE 6, FRAME A, 3 PASS	Victaulic		2,771	2,840	4,190	3,950		1157	1288	1900	1792
	Flange		2,899	3,020				1315	1370		
SIZE 6, FRAME B, 1 PASS	Victaulic		—	2,604	—	6,975		—	1181	—	3162
	Flange		—	2,934				—	1331		
SIZE 6, FRAME B, 2 PASS	Victaulic		—	2,459	—	3,600		—	1115	—	1633
	Flange		—	2,719				—	1233		
SIZE 6, FRAME B, 3 PASS	Victaulic		—	2,770	—	4,858		—	1256	—	2203
	Flange		—	2,950				—	1338		
SIZE 7 FRAME B, 1 PASS	Victaulic		8,305	—	5,783	—		3767	—	2623	—
	Flange		8,635	—				3917	—		
SIZE 7 FRAME B, 2 PASS	Victaulic		7,426	—	2,382	—		3368	—	1080	—
	Flange		7,686	—				3486	—		
SIZE 7 FRAME B, 3 PASS	Victaulic		7,785	—	3,268	—		3531	—	1482	—
	Flange		7,965	—				3612	—		
SIZE 7 FRAME C, 1 PASS	Victaulic		11,001	9,228	7,030	7,591		4990	4186	3188	3443
	Flange		11,331	9,668				5140	4385		
SIZE 7 FRAME C, 2 PASS	Victaulic		9,829	8,003	2,708	3,061		4458	3630	1228	1388
	Flange		10,089	8,333				4576	3682		
SIZE 7 FRAME C, 3 PASS	Victaulic		10,343	8,647	3,866	4,468		4692	3922	1753	—
	Flange		10,053	8,843				4773	—		
SIZE 7 FRAME D, 1 PASS	Victaulic	—	12,940	—	9,365	—	5869	—	4248		
	Flange	—	13,380			—	5927				
SIZE 7 FRAME D, 2 PASS	Victaulic	—	11,170	—	3,607	—	5067	—	1925		
	Flange	—	11,500			—	5102				
SIZE 7 FRAME D, 3 PASS	Victaulic	—	12,042	—	5,398	—	5462	—	—		
	Flange	—	12,238			—	—				

* Add to heat exchanger data for total weights or volumes.
 NOTE: For the total weight of a vessel with a marine waterbox, add these values to the heat exchanger weights (or volumes).

**Table 19 — 19XR,XRV 19XR,XRV Compressor and Motor Weights*—
Standard and High-Efficiency Motors
Compressor Frame Size 2†**

MOTOR CODE	ENGLISH						SI					
	Compressor Weight** (lb)	60 Hz		50 Hz		End Bell Cover Weight (lb)	Compressor Weight** (kg)	60 Hz		50 Hz		End Bell Cover Weight (kg)
		Stator Weight†† (lb)	Rotor Weight (lb)	Stator Weight†† (lb)	Rotor Weight (lb)			Stator Weight†† (kg)	Rotor Weight (kg)	Stator Weight†† (kg)	Rotor Weight (kg)	
STANDARD-EFFICIENCY MOTORS / LOW VOLTAGE (200-575 V)												
BDS	2300	900	190	915	205	185	1043	408	86	415	93	84
BES	2300	915	200	965	220	185	1043	415	91	438	100	84
BFS	2300	975	215	1000	230	185	1043	442	98	454	104	84
BGS	2300	1000	230	1060	250	185	1043	454	104	481	113	84
BHS	2300	1030	240	1105	265	185	1043	467	109	501	120	84
BJS	2300	1105	265	—	—	185	1043	501	120	—	—	84
HIGH-EFFICIENCY MOTORS / LOW VOLTAGE (200-575 V)												
BDH	2300	1030	240	1030	240	185	1043	467	109	467	109	84
BEH	2300	1070	250	1070	250	185	1043	485	113	485	113	84
BFH	2300	1120	265	1120	265	185	1043	508	120	508	120	84
BGH	2300	1175	290	1175	290	185	1043	533	132	533	132	84
BHH	2300	1175	290	1175	290	185	1043	533	132	533	132	84
BJH	2300	1175	290	—	—	185	1043	533	132	—	—	84
JBH	2300	1003	226	1063	248	185	1043	455	103	482	112	84
JCH	2300	1063	248	1113	263	185	1043	482	112	505	119	84
JDH	2300	1113	263	1149	278	185	1043	505	119	521	126	84
JEH	2300	1149	278	1196	295	185	1043	521	126	542	134	84
JFH	2300	1196	295	—	—	185	1043	542	134	—	—	84

* Total compressor weight is the sum of the compressor aerodynamic components (compressor weight column), stator, rotor, and end bell cover weights.

** Compressor aerodynamic component weight only, motor weight not included. Applicable to standard compressors only. For high lift compressors, contact Carrier Chiller Marketing for weights.

† See Model Number Nomenclature.

†† Stator weight includes the stator and shell.

**Table 20 — 19XR,XRV Compressor and Motor Weights*—
Standard and High-Efficiency Motors
Compressor Frame Size 3†**

MOTOR CODE	ENGLISH						SI					
	Compressor Weight** (lb)	60 Hz		50 Hz		End Bell Cover Weight (lb)	Compressor Weight** (kg)	60 Hz		50 Hz		End Bell Cover Weight (kg)
		Stator Weight†† (lb)	Rotor Weight (lb)	Stator Weight†† (lb)	Rotor Weight (lb)			Stator Weight†† (kg)	Rotor Weight (kg)	Stator Weight†† (kg)	Rotor Weight (kg)	
STANDARD-EFFICIENCY MOTORS / LOW VOLTAGE (200-575 V)												
CBS	2816	1146	219	1188	236	274	1277	520	99	539	107	124
CCS	2816	1171	227	1196	242	274	1277	531	103	542	110	124
CDS	2816	1198	237	1258	255	274	1277	543	108	571	116	124
CES	2816	1207	240	1272	258	274	1277	547	109	577	117	124
CLS	2816	1247	249	1328	273	274	1277	566	113	602	124	124
CMS	2816	1270	257	1353	278	274	1277	576	117	614	126	124
CNS	2816	1321	266	1386	282	274	1277	599	121	629	128	124
CPS	2816	1334	269	1401	287	274	1277	605	122	635	130	124
CQS	2816	1353	276	1408	290	274	1277	614	125	639	132	124
CRS	2816	1259	321	—	—	274	1277	571	146	—	—	124
CRS (380V)	2816	1328	346	—	—	274	1277	602	157	—	—	124
HIGH-EFFICIENCY MOTORS / LOW VOLTAGE (200-575 V)												
CBH	2816	1235	239	1290	254	274	1277	560	108	585	115	124
CCH	2816	1260	249	1295	259	274	1277	572	113	587	117	124
CDH	2816	1286	258	1358	273	274	1277	583	117	616	124	124
CEH	2816	1305	265	1377	279	274	1277	592	120	625	127	124
CLH	2816	1324	271	1435	292	274	1277	601	123	651	132	124
CMH	2816	1347	275	1455	298	274	1277	611	125	660	135	124
CNH	2816	1358	278	1467	301	274	1277	616	126	665	137	124
CPH	2816	1401	290	1479	304	274	1277	635	132	671	138	124
CQH	2816	1455	304	1479	304	274	1277	670	138	671	138	124
KBH	2816	1313	276	1353	285	274	1277	596	125	614	129	124
KCH	2816	1353	285	1381	291	274	1277	614	129	626	132	124
KDH	2816	1381	291	1417	307	274	1277	626	132	643	139	124
KEH	2816	1417	307	1441	313	274	1277	643	139	654	142	124
KFH	2816	1441	313	1470	320	274	1277	654	142	667	145	124
KGH	2816	1470	320	1505	333	274	1277	667	145	683	151	124
KHH	2816	1505	333	—	—	274	1277	683	151	—	—	124
UB	2816	1371	316	1391	330	274	1277	622	143	631	150	124
UC	2816	1391	330	1419	344	274	1277	631	150	644	156	124
UD	2816	1419	344	1455	372	274	1277	644	156	660	169	124
UE	2816	1455	372	1479	386	274	1277	660	169	671	175	124
UF	2816	1479	386	1508	400	274	1277	671	175	684	181	124
UG	2816	1508	400	1543	421	274	1277	684	181	700	191	124
UH	2816	1543	421	—	—	274	1277	700	191	—	—	124
HIGH-EFFICIENCY MOTORS / MEDIUM VOLTAGE (2400-4160 V)												
CBH	2816	1114	242	1156	255	274	1277	505	110	524	116	124
CCH	2816	1129	247	1163	257	274	1277	512	112	528	117	124
CDH	2816	1155	253	1190	263	274	1277	524	115	540	119	124
CEH	2816	1175	263	1236	276	274	1277	533	119	561	125	124
CLH	2816	1242	280	1305	296	274	1277	563	127	592	134	124
CMH	2816	1321	303	1305	296	274	1277	599	137	592	134	124
CNH	2816	1369	316	1386	316	274	1277	621	143	629	143	124
CPH	2816	1411	329	1386	316	274	1277	640	149	629	143	124
CQH	2816	1411	329	1428	329	274	1277	640	149	648	149	124

* Total compressor weight is the sum of the compressor aerodynamic components (compressor weight column), stator, rotor, and end bell cover weights.

† See Model Number Nomenclature.

** Compressor aerodynamic component weight only, motor weight not included. Applicable to standard compressors only. For high lift compressors, contact Carrier Chiller Marketing for weights.

†† Stator weight includes the stator and shell.

**TABLE 21 — 19XR,XRV COMPRESSOR AND MOTOR WEIGHTS*—
STANDARD AND HIGH-EFFICIENCY MOTORS
COMPRESSOR FRAME SIZE 4†**

MOTOR CODE	ENGLISH						SI					
	Compressor Weight** (lb) Fixed Ring/ Split Ring	60 Hz		50 Hz		End Bell Cover Weight (lb)	Compressor Weight** (kg) Fixed Ring/ Split Ring	60 Hz		50 Hz		End Bell Cover Weight (kg)
		Stator Weight†† (lb)	Rotor Weight (lb)	Stator Weight†† (lb)	Rotor Weight (lb)			Stator Weight†† (kg)	Rotor Weight (kg)	Stator Weight†† (kg)	Rotor Weight (kg)	
STANDARD-EFFICIENCY MOTORS / MEDIUM VOLTAGE (2400-4160 v)												
DKS	3425 / 4211	2200	480	—	—	236	1554 / 1910	998	218	—	—	107
STANDARD-EFFICIENCY MOTORS / MEDIUM VOLTAGE (6300-6900 v)												
DJS	3425 / 4211	2159	508	—	—	318	1554 / 1910	979	230	—	—	142
HIGH-EFFICIENCY MOTORS / LOW VOLTAGE (200-575 v)												
LBH	3425 / 4211	1875	364	1935	387	317	1554 / 1910	850	165	878	176	144
LCH	3425 / 4211	1935	389	2008	405	317	1554 / 1910	878	176	911	184	144
LDH	3425 / 4211	2008	406	2056	417	317	1554 / 1910	911	184	933	189	144
LEH	3425 / 4211	2043	417	2092	433	317	1554 / 1910	927	189	949	196	144
LFH	3425 / 4211	2092	434	2156	444	317	1554 / 1910	949	197	978	201	144
LGH	3425 / 4211	2156	444	2199	458	317	1554 / 1910	978	201	997	208	144
LHH	3425 / 4211	2199	458	2230	458	317	1554 / 1910	997	208	1012	208	144
HIGH-EFFICIENCY MOTORS / MEDIUM VOLTAGE (2400-4160 v)												
DJH	3425 / 4211	2100	452	2320	587	318	1554 / 1910	953	205	1052	266	144
HIGH-EFFICIENCY MOTORS / MEDIUM VOLTAGE (6300-6900 v)												
DJH	3425 / 4211	2380	614	2380	614	318	1554 / 1910	1080	279	1080	279	144

* Total compressor weight is the sum of the compressor aerodynamic components (compressor weight column), stator, rotor, and end bell cover weights.

† See Model Number Nomenclature.

** Compressor aerodynamic component weight only, motor weight not included. Applicable to standard compressors only. For high lift compressors, contact Carrier Chiller Marketing for weights.

†† Stator weight includes the stator and shell.

**TABLE 22 — 19XR,XRV COMPRESSOR AND MOTOR WEIGHTS*—
STANDARD AND HIGH-EFFICIENCY MOTORS
COMPRESSOR FRAME SIZE 5†**

MOTOR CODE	ENGLISH						SI					
	Compressor Weight** (lb)	60 Hz		50 Hz		End Bell Cover Weight (lb)	Compressor Weight** (kg)	60 Hz		50 Hz		End Bell Cover Weight (kg)
		Stator Weight†† (lb)	Rotor Weight (lb)	Stator Weight†† (lb)	Rotor Weight (lb)			Stator Weight†† (kg)	Rotor Weight (kg)	Stator Weight†† (kg)	Rotor Weight (kg)	
STANDARD-EFFICIENCY MOTORS / MEDIUM VOLTAGE (2400-4160 v)												
EQS	7285	3081	872	—	—	414	3304	1398	396	—	—	188
HIGH-EFFICIENCY MOTORS / LOW VOLTAGE (200-575 v)												
MBH	7285	2795	645	2856	665	414	3304	1268	293	1295	302	188
MCH	7285	2873	672	2925	693	414	3304	1303	305	1327	314	188
MDH	7285	2906	684	3013	724	414	3304	1318	310	1367	328	188
MEH	7285	2956	704	3071	737	414	3304	1341	319	1392	334	188
MFH	7285	3034	724	3153	791	414	3304	1376	328	1430	359	188
MGH	7285	3071	737	—	—	414	3304	1393	334	—	—	188
HIGH-EFFICIENCY MOTORS / MEDIUM VOLTAGE (2400-4160 v)												
EPH	7285	3081	872	3298	974	414	3304	1398	396	1496	442	188
HIGH-EFFICIENCY MOTORS / MEDIUM VOLTAGE (6300-6900 v)												
EPH	7285	3081	872	3288	974	414	3304	1398	396	1491	442	188
HIGH-EFFICIENCY MOTORS / HIGH VOLTAGE (10000-11000 v)												
MCH	7285	—	—	3956	678	414	3304	—	—	1794	308	188
MDH	7285	—	—	3956	678	414	3304	—	—	1794	308	188
MFH	7285	—	—	4062	719	414	3304	—	—	1842	326	188
MGH	7285	3820	657	—	—	414	3304	1733	298	—	—	188
MHH	7285	3820	657	—	—	414	3304	1733	298	—	—	188
HIGH-EFFICIENCY MOTORS / HIGH VOLTAGE (13800 v)												
MHH	7285	3779	646	—	—	414	3304	1714	293	—	—	188

* Total compressor weight is the sum of the compressor aerodynamic components (compressor weight column), stator, rotor, and end bell cover weights.

† See Model Number Nomenclature.

** Compressor aerodynamic component weight only, motor weight not included. Applicable to standard compressors only. For high lift compressors, contact Carrier Chiller Marketing for weights.

†† Stator weight includes the stator and shell.

**Table 23 — 19XR,XRC Compressor and Motor Weights*—
Standard and High-Efficiency Motors
Compressor Frame Size C†**

Motor Code	ENGLISH						SI					
	Compressor Weight** (lb)	50Hz		60Hz		End Cover (lb)	Compressor Weight** (kg)	50Hz		60Hz		End Cover (kg)
		Stator Weight†† (lb)	Rotor Weight (lb)	Stator Weight†† (lb)	Rotor Weight (lb)			Stator Weight†† (kg)	Rotor Weight (kg)	Stator Weight†† (kg)	Rotor Weight (kg)	
HIGH EFFICIENCY MOTORS / LOW VOLTAGE (230 - 575 V)												
VB	3265	1936	474	1876	459	317	1481	878	215	851	208	144
VC	3265	2008	494	1936	474	317	1481	911	224	878	215	144
VD	3265	2057	518	2008	494	317	1481	933	235	911	224	144
VE	3265	2092	534	2057	518	317	1481	949	242	933	235	144
VF	3265	2156	558	2092	534	317	1481	978	253	949	242	144
VG	3265	2200	591	2156	558	317	1481	998	268	978	253	144
VH	3265	2200	591	2200	591	317	1481	998	268	998	268	144
LB	3265	1935	387	1875	373	317	1481	878	176	851	169	144
LC	3265	2008	405	1935	387	317	1481	911	184	878	176	144
LD	3265	2056	417	2008	405	317	1481	933	189	911	184	144
LE	3265	2092	433	2056	417	317	1481	949	196	933	189	144
LF	3265	2156	444	2092	433	317	1481	978	201	949	196	144
LG	3265	2199	458	2156	444	317	1481	997	208	978	201	144
LH	3265	2230	458	2199	458	317	1481	1012	208	997	208	144
HIGH EFFICIENCY MOTORS / LOW VOLTAGE (400 V)												
VB	3678	1936	474	—	—	317	1668	878	215	—	—	144
VC	3678	2008	494	—	—	317	1668	911	224	—	—	144
VD	3678	2057	518	—	—	317	1668	933	235	—	—	144
VE	3678	2092	534	—	—	317	1668	949	242	—	—	144
VF	3678	2156	558	—	—	317	1668	978	253	—	—	144
VG	3678	2200	591	—	—	317	1668	998	268	—	—	144
VH	3678	2200	591	—	—	317	1668	998	268	—	—	144
HIGH EFFICIENCY MOTORS / LOW VOLTAGE (380/3/60 or 460/3/60 or 575/3/60 V)												
VB	3678	1876	459	—	—	317	1668	851	208	—	—	144
VC	3678	1936	474	—	—	317	1668	878	215	—	—	144
VD	3678	2008	494	—	—	317	1668	911	224	—	—	144
VE	3678	2057	518	—	—	317	1668	933	235	—	—	144
VF	3678	2092	534	—	—	317	1668	949	242	—	—	144
VG	3678	2156	558	—	—	317	1668	978	253	—	—	144
VH	3678	2200	591	—	—	317	1668	998	268	—	—	144
HIGH EFFICIENCY MOTORS / MEDIUM VOLTAGE (3000 - 6900 V)												
DB	3265	1950	405	1950	405	338	1481	885	184	885	184	153
DD	3265	2025	429	2025	429	338	1481	919	195	919	195	153
DF	3265	2100	452	2100	452	338	1481	953	205	953	205	153
DH	3265	2380	522	2250	480	338	1481	1080	237	1021	218	153
HIGH EFFICIENCY MOTORS / HIGH VOLTAGE (10000 V)												
LD	3265	2659	646	—	—	413	1481	1206	293	—	—	187
LF	3265	2665	646	—	—	413	1481	1209	293	—	—	187
LH	3265	2760	666	—	—	413	1481	1252	302	—	—	187
HIGH EFFICIENCY MOTORS / HIGH VOLTAGE (11000 V)												
LD	3678	2659	646	—	—	413	1668	1206	293	—	—	187
LF	3678	2659	646	—	—	413	1668	1209	293	—	—	187
LH	3678	2754	666	—	—	413	1668	1252	302	—	—	187

* Total compressor weight is the sum of the compressor aerodynamic components (compressor weight column), stator, rotor, and end bell cover weights.

** Compressor aerodynamic component weight only, motor weight not included. Applicable to standard compressors only.

† See Model Number Nomenclature.

†† Stator weight includes the stator and shell.

**Table 24 — 19XR,XRV Compressor and Motor Weights*—
Standard and High-Efficiency Motors
Compressor Frame Size E†**

MOTOR CODE	ENGLISH						SI					
	Compressor Weight** (lb)	60 Hz		50 Hz		End Bell Cover Weight (lb)	Compressor Weight** (lb)	60 Hz		50 Hz		End Bell Cover Weight (lb)
		Stator Weight†† (lb)	Rotor Weight (kg)	Stator Weight†† (lb)	Rotor Weight (kg)			Stator Weight†† (lb)	Rotor Weight (kg)	Stator Weight†† (lb)	Rotor Weight (kg)	
STANDARD-EFFICIENCY MOTORS / LOW VOLTAGE (380-575 V)												
6H	4853	2843	741	2943	775	414	2201	1290	336	1335	352	188
6J	4853	2826	741	2943	775	414	2201	1281	336	1335	352	188
6K	4853	2943	775	2997	810	414	2201	1335	352	1359	367	188
6L	4853	2932	775	2997	810	414	2201	1330	352	1359	367	188
6M	4853	2986	810	3096	862	414	2201	1354	367	1404	391	188
6N	4853	2986	810	3203	914	414	2201	1354	367	1453	415	188
6P	4853	2986	810	3203	914	414	2201	1354	367	1453	415	188
STANDARD-EFFICIENCY MOTORS / MEDIUM VOLTAGE (2400-4160 V)												
6H	4853	2744	706	2818	741	414	2201	1245	320	1278	336	188
6J	4853	2816	741	2892	775	414	2201	1277	336	1312	352	188
6K	4853	2816	741	2930	775	414	2201	1277	336	1329	352	188
6L	4853	2808	741	3005	810	414	2201	1274	336	1363	367	188
6M	4853	2892	775	3005	810	414	2201	1322	352	1363	367	188
6N	4853	2997	775	3143	879	414	2201	1359	352	1426	399	188
6P	4853	2967	810	3144	879	414	2201	1346	367	1426	399	188
6Q	4853	3081	872	—	—	414	2201	1398	396	—	—	188
HIGH-EFFICIENCY MOTORS / LOW VOLTAGE (380-460 V)												
EH	4853	2939	776	2995	810	414	2201	1333	352	1359	367	188
EJ	4853	2944	776	3002	810	414	2201	1335	352	1362	367	188
EK	4853	2992	810	3110	862	414	2201	1357	367	1411	391	188
EL	4853	2299	810	3099	862	414	2201	1043	367	1406	391	188
EM	4853	2965	810	3210	914	414	2201	1345	367	1456	415	188
EN	4853	3015	855	3293	974	414	2201	1368	388	1494	442	188
EP	4853	3029	855	3289	974	414	2201	1374	388	1492	442	188
HIGH-EFFICIENCY MOTORS / LOW VOLTAGE (400-460 V)												
MB	4853	2795	645	2856	665	414	2201	1268	293	1295	302	188
MC	4853	2873	672	2925	693	414	2201	1303	305	1327	314	188
MD	4853	2906	684	3013	724	414	2201	1318	310	1367	328	188
ME	4853	2956	704	3071	737	414	2201	1341	319	1392	334	188
MF	4853	3034	724	3153	791	414	2201	1376	328	1430	359	188
MG	4853	3071	737	—	—	414	2201	1393	334	—	—	188
HIGH-EFFICIENCY MOTORS / MEDIUM VOLTAGE (2400-4160 V)												
EH	4853	2939	776	2997	810	414	2201	1333	352	1359	367	188
EJ	4853	2999	810	3108	862	414	2201	1360	367	1410	391	188
EK	4853	2988	810	3102	862	414	2201	1355	367	1407	391	188
EL	4853	2981	810	3065	872	414	2201	1352	367	1390	396	188
EM	4853	3031	855	3077	872	414	2201	1375	388	1396	396	188
EN	4853	3075	872	3260	974	414	2201	1395	396	1479	442	188
EP	4853	3081	872	3298	974	414	2201	1398	396	1496	442	188
HIGH-EFFICIENCY MOTORS / MEDIUM VOLTAGE (6300-6900 V)												
EH	4853	2998	810	3097	862	414	2201	1360	367	1405	391	188
EJ	4853	3029	855	3100	862	414	2201	1374	388	1406	391	188
EK	4853	3049	855	3064	872	414	2201	1383	388	1390	396	188
EL	4853	3068	872	3060	872	414	2201	1390	396	1388	396	188
EM	4853	—	—	3072	872	414	2201	—	—	1393	396	188
EN	4853	3075	872	3260	974	414	2201	1395	396	1479	442	188
EP	4853	3081	872	3288	974	414	2201	1398	396	1491	442	188

**Table 24 — 19XR,XRV Compressor and Motor Weights*—
Standard and High-Efficiency Motors
Compressor Frame Size E†(cont)**

MOTOR CODE	ENGLISH						SI					
	Compressor Weight** (lb)	60 Hz		50 Hz		End Bell Cover Weight (lb)	Compressor Weight** (lb)	60 Hz		50 Hz		End Bell Cover Weight (lb)
		Stator Weight†† (lb)	Rotor Weight (kg)	Stator Weight†† (lb)	Rotor Weight (kg)			Stator Weight†† (lb)	Rotor Weight (kg)	Stator Weight†† (lb)	Rotor Weight (kg)	
HIGH-EFFICIENCY MOTORS / HIGH VOLTAGE (10000-11000 V)												
MD	4853	—	—	3956	678	414	2201	—	—	1794	308	188
MF	4853	—	—	4062	719	414	2201	—	—	1842	326	188
MH	4853	3820	657	—	—	414	2201	1733	298	—	—	188
HIGH-EFFICIENCY MOTORS / HIGH VOLTAGE (13800 V)												
MH	4853	3779	646	—	—	414	2201	1714	293	—	—	188

* Total compressor weight is the sum of the compressor aerodynamic components (compressor weight column), stator, rotor, and end bell cover weights.

** Compressor aerodynamic component weight only, motor weight not included. Applicable to standard compressors only. For high lift compressors, contact Carrier Chiller Marketing for weights.

† See Model Number Nomenclature.

†† Stator weight includes the stator and shell.

**Table 25 — 19XR Compressor and Motor Weights* — High-Efficiency Motors
Two-Stage Compressor Frame Size 6, 60 Hz**

MOTOR CODE	ENGLISH				SI			
	COMPRESSOR WEIGHT† (lb)	STATOR AND HOUSING WEIGHT (lb)	ROTOR AND SHAFT WEIGHT (lb)	END BELL COVER WEIGHT (lb)	COMPRESSOR WEIGHT† (kg)	STATOR AND HOUSING WEIGHT (kg)	ROTOR AND SHAFT WEIGHT (kg)	END BELL COVER WEIGHT (kg)
Voltage: 380-3-60								
N	10,287	1153	5928	1021	4666	2689	523	463
P	10,287	1153	5928	1021	4666	2689	523	463
Q	10,287	1179	6107	1021	4666	2770	535	463
R	10,287	1153	6109	1021	4666	2771	523	463
S	10,287	1153	6144	1021	4666	2787	523	463
T	10,287	1179	6151	1021	4666	2790	535	463
Voltage: 460-3-60								
N	10,287	1153	5946	1021	4666	2697	523	463
P	10,287	1153	5948	1021	4666	2698	523	463
Q	10,287	1179	6107	1021	4666	2770	535	463
R	10,287	1179	6111	1021	4666	2772	535	463
S	10,287	1188	6149	1021	4666	2789	539	463
T	10,287	1188	6153	1021	4666	2791	539	463
Voltage: 2400-3-60								
N	10,287	5929	1212	1021	4666	2689	550	463
P	10,287	6021	1230	1021	4666	2731	558	463
Q	10,287	6112	1248	1021	4666	2772	566	463
R	10,287	6190	1264	1021	4666	2808	573	463
S	10,287	6268	1280	1021	4666	2843	581	463
T	10,287	6259	1280	1021	4666	2839	581	463
Voltage: 3300-3-60								
N	10,287	5927	1212	1021	4666	2688	550	463
P	10,287	6019	1230	1021	4666	2730	558	463
Q	10,287	6110	1248	1021	4666	2771	566	463
R	10,287	6187	1264	1021	4666	2806	573	463
S	10,287	6263	1280	1021	4666	2841	581	463
T	10,287	6277	1280	1021	4666	2847	581	463
Voltage: 4160-3-60								
N	10,287	6103	1247	1021	4666	2768	566	463
P	10,287	6103	1248	1021	4666	2768	566	463
Q	10,287	6103	1248	1021	4666	2768	566	463
R	10,287	6185	1264	1021	4666	2805	573	463
S	10,287	6268	1280	1021	4666	2843	581	463
T	10,287	6268	1280	1021	4666	2843	581	463
Voltage: 6900-3-60								
N	10,287	6558	1316	1021	4666	2975	600	463
P	10,287	6559	1316	1021	4666	2975	600	463
Q	10,287	6559	1316	1021	4666	2975	600	463
R	10,287	6566	1316	1021	4666	2978	600	463
S	10,287	6574	1316	1021	4666	2982	600	463
T	10,287	6604	1351	1021	4666	2996	613	463
Voltage: 11000-3-60								
N	10,287	6587	1351	1021	4666	2988	613	463
P	10,287	6587	1351	1021	4666	2988	613	463
Q	10,287	6587	1351	1021	4666	2988	613	463
R	10,287	6716	1385	1021	4666	3036	628	463
S	10,287	6844	1419	1021	4666	3104	644	463
T	10,287	6844	1419	1021	4666	3104	644	463

**Table 25 — 19XR Compressor and Motor Weights* — High-Efficiency Motors
Two-Stage Compressor Frame Size 6, 60 Hz (cont)**

MOTOR CODE	ENGLISH				SI			
	COMPRESSOR WEIGHT† (lb)	STATOR AND HOUSING WEIGHT (lb)	ROTOR AND SHAFT WEIGHT (lb)	END BELL COVER WEIGHT (lb)	COMPRESSOR WEIGHT† (kg)	STATOR AND HOUSING WEIGHT (kg)	ROTOR AND SHAFT WEIGHT (kg)	END BELL COVER WEIGHT (kg)
Voltage: 13800-3-60								
N	10,287	6554	1351	1021	4666	2973	613	463
P	10,287	6554	1351	1021	4666	2973	613	463
Q	10,287	6554	1351	1021	4666	2973	613	463
R	10,287	6709	1385	1021	4666	3043	628	463
S	10,287	6864	1419	1021	4666	3113	644	463
T	10,287	6864	1419	1021	4666	3113	644	463

* Total compressor weight is the sum of the compressor aerodynamic components (compressor weight column), stator, rotor, and end bell cover weights.

† Compressor aerodynamic component weight only, motor weight not included. Applicable to standard compressors only.

**Table 26 — 19XR Compressor and Motor Weights* — High-Efficiency Motors
Two-Stage Compressor Frame Size 6, 50 Hz**

MOTOR CODE	ENGLISH				SI			
	COMPRESSOR WEIGHT† (lb)	STATOR AND HOUSING WEIGHT (lb)	ROTOR AND SHAFT WEIGHT (lb)	END BELL COVER WEIGHT (lb)	COMPRESSOR WEIGHT† (kg)	STATOR AND HOUSING WEIGHT (kg)	ROTOR AND SHAFT WEIGHT (kg)	END BELL COVER WEIGHT (kg)
Voltage: 400-3-50								
N	10,287	1153	5917	1021	4666	2684	523	463
P	10,287	1153	5919	1021	4666	2685	523	463
Q	10,287	1179	6105	1021	4666	2769	535	463
R	10,287	1179	6107	1021	4666	2770	535	463
S	10,287	1188	6149	1021	4666	2789	539	463
T	10,287	1188	6151	1021	4666	2790	539	463
Voltage: 3000-3-50								
N	10,287	5918	1212	1021	4666	2684	550	463
P	10,287	6006	1230	1021	4666	2724	558	463
Q	10,287	6094	1248	1021	4666	2764	566	463
R	10,287	6184	1264	1021	4666	2805	573	463
S	10,287	6274	1280	1021	4666	2846	581	463
T	10,287	6296	1280	1021	4666	2856	581	463
Voltage: 3300-3-50								
N	10,287	5913	1212	1021	4666	2682	550	463
P	10,287	6007	1230	1021	4666	2725	558	463
Q	10,287	6101	1248	1021	4666	2767	566	463
R	10,287	6192	1264	1021	4666	2809	573	463
S	10,287	6283	1280	1021	4666	2850	581	463
T	10,287	6266	1280	1021	4666	2842	581	463
Voltage: 6300-3-50								
N	10,287	6277	1280	1021	4666	2847	581	463
P	10,287	6333	1298	1021	4666	2873	589	463
Q	10,287	6389	1316	1021	4666	2898	600	463
R	10,287	6473	1316	1021	4666	2936	600	463
S	10,287	6556	1316	1021	4666	2974	600	463
T	10,287	6609	1351	1021	4666	2998	613	463
Voltage: 10000-3-50								
N	10,287	6281	1280	1021	4666	2849	581	463
P	10,287	6281	1281	1021	4666	2849	581	463
Q	10,287	6281	1281	1021	4666	2849	581	463
R	10,287	6441	1316	1021	4666	2922	600	463
S	10,287	6600	1351	1021	4666	2994	613	463
T	10,287	6156	1351	1021	4666	2792	613	463
Voltage: 11000-3-50								
N	10,287	6600	1351	1021	4666	2994	613	463
P	10,287	6600	1351	1021	4666	2994	613	463
Q	10,287	6600	1351	1021	4666	2994	613	463
R	10,287	6765	1385	1021	4666	3069	628	463
S	10,287	6930	1419	1021	4666	3143	644	463
T	10,287	6930	1419	1021	4666	3143	644	463

* Total compressor weight is the sum of the compressor aerodynamic components (compressor weight column), stator, rotor, and end bell cover weights.

† Compressor aerodynamic component weight only, motor weight not included. Applicable to standard compressors only.

**Table 27 — 19XR Compressor and Motor Weights* — High-Efficiency Motors
Two-Stage Compressor Frame Size 7, 60 Hz**

MOTOR CODE	ENGLISH				SI			
	COMPRESSOR WEIGHT† (lb)	STATOR AND HOUSING WEIGHT (lb)	ROTOR AND SHAFT WEIGHT (lb)	END BELL COVER WEIGHT (lb)	COMPRESSOR WEIGHT† (kg)	STATOR AND HOUSING WEIGHT (kg)	ROTOR AND SHAFT WEIGHT (kg)	END BELL COVER WEIGHT (kg)
Voltage: 2400-3-60								
U	16,024	6719	1443	983	7268	3048	654	446
V	16,024	6718	1443	983	7268	3047	654	446
W	16,024	6717	1443	983	7268	3047	654	446
X	16,024	6811	1460	983	7268	3089	662	446
Y	16,024	6906	1476	983	7268	3132	670	446
Z	16,024	7073	1509	983	7268	3208	684	446
Voltage: 3300-3-60								
U	16,024	6723	1443	983	7268	3049	654	446
V	16,024	6730	1443	983	7268	3053	654	446
W	16,024	6736	1443	983	7268	3055	654	446
X	16,024	6816	1460	983	7268	3092	662	446
Y	16,024	6895	1476	983	7268	3128	670	446
Z	16,024	7055	1509	983	7268	3200	684	446
Voltage: 4160-3-60								
U	16,024	6739	1443	983	7268	3057	654	446
V	16,024	6721	1443	983	7268	3049	654	446
W	16,024	6703	1443	983	7268	3040	654	446
X	16,024	6778	1460	983	7268	3074	662	446
Y	16,024	6853	1476	983	7268	3108	670	446
Z	16,024	7069	1509	983	7268	3206	684	446
Voltage: 6900-3-60								
U	16,024	6730	1443	983	7268	3053	654	446
V	16,024	6909	1476	983	7268	3134	670	446
W	16,024	7088	1509	983	7268	3215	684	446
X	16,024	7076	1509	983	7268	3210	684	446
Y	16,024	7064	1509	983	7268	3204	684	446
Z	16,024	7141	1542	983	7268	3239	699	446
Voltage: 11000-3-60								
G	16,024	7434	1700	983	7268	3372	771	486
H	16,024	7602	1768	983	7268	3448	802	486
J	16,024	7602	1768	983	7268	3448	802	486
K	16,024	7602	1768	983	7268	3448	802	446
L	16,024	7602	1768	983	7268	3448	802	486
M	16,024	7767	1837	983	7268	3523	833	486
U	16,024	7042	1509	983	7268	3194	684	446
V	16,024	7085	1526	983	7268	3214	692	446
W	16,024	7128	1542	983	7268	3233	699	446
X	16,024	7131	1542	983	7268	3235	699	446
Y	16,024	7135	1542	983	7268	3236	699	446
Z	16,024	7313	1575	983	7268	3317	714	446
Voltage: 13800-3-60								
U	16,024	7073	1509	983	7268	3208	684	446
V	16,024	7109	1526	983	7268	3225	692	446
W	16,024	7146	1542	983	7268	3241	699	446
X	16,024	7146	1542	983	7268	3241	699	446
Y	16,024	7146	1542	983	7268	3241	699	446
Z	16,024	7295	1575	983	7268	3309	714	446

* Total compressor weight is the sum of the compressor aerodynamic components (compressor weight column), stator, rotor, and end bell cover weights.

† Compressor aerodynamic component weight only, motor weight not included. Applicable to standard compressors only.

**Table 28 — 19XR Compressor and Motor Weights* — High-Efficiency Motors
Two-Stage Compressor Frame Size 7, 50 Hz**

MOTOR CODE	ENGLISH				SI			
	COMPRESSOR WEIGHT† (lb)	STATOR AND HOUSING WEIGHT (lb)	ROTOR AND SHAFT WEIGHT (lb)	END BELL COVER WEIGHT (lb)	COMPRESSOR WEIGHT† (kg)	STATOR AND HOUSING WEIGHT (kg)	ROTOR AND SHAFT WEIGHT (kg)	END BELL COVER WEIGHT (kg)
Voltage: 3000-3-50								
U	16,024	6725	1443	983	7268	3050	654	446
V	16,024	6716	1443	983	7268	3046	654	446
W	16,024	6706	1443	983	7268	3042	654	446
X	16,024	6802	1460	983	7268	3085	662	446
Y	16,024	6899	1476	983	7268	3129	670	446
Z	16,024	7066	1509	983	7268	3205	684	446
Voltage: 3300-3-50								
U	16,024	6743	1443	983	7268	3059	654	446
V	16,024	6739	1443	983	7268	3057	654	446
W	16,024	6734	1443	983	7268	3054	654	446
X	16,024	6826	1460	983	7268	3096	662	446
Y	16,024	6917	1476	983	7268	3137	670	446
Z	16,024	7075	1509	983	7268	3209	684	446
Voltage: 6300-3-50								
U	16,024	6743	1443	983	7268	3059	654	446
V	16,024	6900	1476	983	7268	3130	670	446
W	16,024	7058	1509	983	7268	3201	684	446
X	16,024	7130	1526	983	7268	3234	692	446
Y	16,024	7203	1542	983	7268	3267	699	446
Z	16,024	7203	1542	983	7268	3267	699	446
Voltage: 10000-3-50								
G	16,024	7269	1631	983	7268	3297	740	446
H	16,024	7269	1631	983	7268	3297	740	446
J	16,024	7269	1631	983	7268	3297	740	446
K	16,024	7602	1768	983	7268	3448	802	446
L	16,024	7602	1768	983	7268	3448	802	446
M	16,024	7769	1837	983	7268	3523	833	446
U	16,024	6904	1476	983	7268	3132	670	446
V	16,024	6907	1476	983	7268	3133	670	446
W	16,024	6910	1476	983	7268	3134	670	446
X	16,024	7074	1509	983	7268	3209	684	446
Y	16,024	7238	1542	983	7268	3283	699	446
Z	16,024	7401	1575	983	7268	3357	714	446
Voltage: 11000-3-50								
G	16,024	7434	1700	983	7268	3372	771	446
H	16,024	7602	1768	983	7268	3448	802	446
J	16,024	7602	1768	983	7268	3448	802	446
K	16,024	7602	1768	983	7268	3448	802	446
L	16,024	7602	1768	983	7268	3448	802	446
M	16,024	7767	1837	983	7268	3523	833	446
U	16,024	7139	1509	983	7268	3238	684	446
V	16,024	7186	1526	983	7268	3260	692	446
W	16,024	7234	1542	983	7268	3281	699	446
X	16,024	7234	1542	983	7268	3281	699	446
Y	16,024	7234	1542	983	7268	3281	699	446
Z	16,024	7383	1575	983	7268	3349	714	446

* Total compressor weight is the sum of the compressor aerodynamic components (compressor weight column), stator, rotor, and end bell cover weights.

† Compressor aerodynamic component weight only, motor weight not included. Applicable to standard compressors only.

Table 29 — 19XR Waterbox Cover Weights Cooler Frames 2, 3

WATERBOX DESCRIPTION	ENGLISH (LB)				METRIC (KG)			
	COOLER				COOLER			
	FRAME 2		FRAME 3		FRAME 2		FRAME 3	
	STD NOZZLES	FLANGED	STD NOZZLES	FLANGED	STD NOZZLES	FLANGED	STD NOZZLES	FLANGED
NIH, 1 Pass Cover, 150 psig (1034 kPa)	287	318	287	318	130	144	130	144
NIH, 2 Pass Cover, 150 psig (1034 kPa)	287	340	287	340	130	154	130	154
NIH, 3 Pass Cover, 150 psig (1034 kPa)	294	310	294	310	133	141	133	141
MWB End Cover, 150 psig (1034 kPa)	315	315	315	315	143	143	143	143
NIH/MWB Return Cover, 150 psig (1034 kPa)	243	243	243	243	110	110	110	110
NIH, 1 Pass Cover, 300 psig (2068 kPa)	411	486	411	486	186	220	186	220
NIH, 2 Pass Cover, 300 psig (2068 kPa)	411	518	411	518	186	235	186	235
NIH, 3 Pass Cover, 300 psig (2068 kPa)	433	468	433	468	196	212	196	212
NIH Plain End Cover, 300 psig (2068 kPa)	291	291	291	291	132	132	132	132
MWB End Cover, 300 psig (2068 kPa)	619	619	619	619	281	281	281	281
MWB Return Cover, 300 psig (2068 kPa)	445	445	445	445	202	202	202	202

LEGEND

NIH — Nozzle-in-Head
MWB — Marine Waterbox
STD — Standard

NOTE: Weight for NIH 2-pass cover, 150 psig (1034 kPa), is included in the heat exchanger weights shown in the heat exchanger weight tables.

Table 30 — 19XR Waterbox Cover Weights Condenser Frames 2, 3

WATERBOX DESCRIPTION	ENGLISH (LB)				METRIC (KG)			
	CONDENSER				CONDENSER			
	FRAME 2		FRAME 3		FRAME 2		FRAME 3	
	STD NOZZLES	FLANGED	STD NOZZLES	FLANGED	STD NOZZLES	FLANGED	STD NOZZLES	FLANGED
NIH, 1 Pass Cover, 150 psig (1034 kPa)	260	297	260	297	118	135	118	135
NIH, 2 Pass Cover, 150 psig (1034 kPa)	265	318	265	318	120	144	120	144
NIH, 3 Pass Cover, 150 psig (1034 kPa)	272	288	272	288	123	131	123	131
MWB End Cover, 150 psig (1034 kPa)	234	234	234	234	106	106	106	106
NIH/MWB Return Cover, 150 psig (1034 kPa)	225	225	225	225	102	102	102	102
NIH, 1 Pass Cover, 300 psig (2068 kPa)	379	454	379	454	172	206	172	206
NIH, 2 Pass Cover, 300 psig (2068 kPa)	379	486	379	486	172	220	172	220
NIH, 3 Pass Cover, 300 psig (2068 kPa)	401	436	401	436	182	198	182	198
NIH Plain End Cover, 300 psig (2068 kPa)	270	270	270	270	122	122	122	122
MWB End Cover, 300 psig (2068 kPa)	474	474	474	474	215	215	215	215
MWB Return Cover, 300 psig (2068 kPa)	359	359	359	359	163	163	163	163

LEGEND

NIH — Nozzle-in-Head
MWB — Marine Waterbox
STD — Standard

NOTE: Weight for NIH 2-pass cover, 150 psig (1034 kPa), is included in the heat exchanger weights shown in the heat exchanger weight tables.

Table 31 — 19XR Waterbox Cover Weights Cooler Frames 4, 5

WATERBOX DESCRIPTION	ENGLISH (LB)				METRIC (KG)			
	COOLER				COOLER			
	FRAME 4		FRAME 5		FRAME 4		FRAME 5	
	STD NOZZLES	FLANGED	STD NOZZLES	FLANGED	STD NOZZLES	FLANGED	STD NOZZLES	FLANGED
NIH, 1 Pass Cover, 150 psig (1034 kPa)	148	185	168	229	67	84	76	104
NIH, 2 Pass Cover, 150 psig (1034 kPa)	202	256	224	276	92	116	102	125
NIH, 3 Pass Cover, 150 psig (1034 kPa)	473	489	617	634	215	222	280	288
MWB End Cover, 150 psig (1034 kPa)	317	317	393	393	144	144	178	178
MWB Return Cover, 150 psig (1034 kPa)	138	138	154	154	63	63	70	70
NIH, 1 Pass Cover, 300 psig (2068 kPa)	633	709	764	839	287	322	347	381
NIH, 2 Pass Cover, 300 psig (2068 kPa)	626	689	761	867	284	313	345	394
NIH, 3 Pass Cover, 300 psig (2068 kPa)	660	694	795	830	299	315	361	376
NIH/MWB End Cover, 300 psig (2068 kPa)	522	522	658	658	237	237	298	298

LEGEND

- NIH — Nozzle-in-Head
- MWB — Marine Waterbox
- STD — Standard

NOTE: Weight for NIH 2-pass cover, 150 psig (1034 kPa), is included in the heat exchanger weights shown in the heat exchanger weight tables.

Table 32 — 19XR Waterbox Cover Weights Condenser Frames 4, 5

WATERBOX DESCRIPTION	ENGLISH (LB)				METRIC (KG)			
	CONDENSER				CONDENSER			
	FRAME 4		FRAME 5		FRAME 4		FRAME 5	
	STD NOZZLES	FLANGED	STD NOZZLES	FLANGED	STD NOZZLES	FLANGED	STD NOZZLES	FLANGED
NIH, 1 Pass Cover, 150 psig (1034 kPa)	148	185	168	229	67	84	76	104
NIH, 2 Pass Cover, 150 psig (1034 kPa)	191	245	224	298	87	111	102	135
NIH, 3 Pass Cover, 150 psig (1034 kPa)	503	519	629	655	228	235	285	297
MWB End Cover, 150 psig (1034 kPa)	317	317	393	393	144	144	178	178
MWB Return Cover, 150 psig (1034 kPa)	138	138	154	154	63	63	70	70
NIH, 1 Pass Cover, 300 psig (2068 kPa)	633	709	764	839	287	322	347	381
NIH, 2 Pass Cover, 300 psig (2068 kPa)	622	729	727	878	282	331	330	393
NIH, 3 Pass Cover, 300 psig (2068 kPa)	655	689	785	838	297	313	356	376
NIH/MWB End Cover, 300 psig (2068 kPa)	522	522	658	658	237	237	298	298

LEGEND

- NIH — Nozzle-in-Head
- MWB — Marine Waterbox
- STD — Standard

NOTE: Weight for NIH 2-pass cover, 150 psig (1034 kPa), is included in the heat exchanger weights shown in the heat exchanger weight tables.

Table 33 — 19XR Waterbox Cover Weights Cooler Frames 6, 7

WATERBOX DESCRIPTION	ENGLISH (LB)				METRIC (KG)			
	COOLER				COOLER			
	FRAME 6		FRAME 7		FRAME 6		FRAME 7	
	STD NOZZLES	FLANGED	STD NOZZLES	FLANGED	STD NOZZLES	FLANGED	STD NOZZLES	FLANGED
NIH, 1 Pass Cover, 150 psig (1034 kPa)	187	223	329	441	85	101	149	200
NIH, 2 Pass Cover, 150 psig (1034 kPa)	257	330	426	541	117	150	193	245
NIH, 3 Pass Cover, 150 psig (1034 kPa)	765	791	1250	1291	347	359	567	586
MWB End Cover, 150 psig (1034 kPa)	487	487	844	844	221	221	383	383
MWB Return Cover, 150 psig (1034 kPa)	172	172	315	315	78	78	143	143
NIH, 1 Pass Cover, 300 psig (2068 kPa)	978	1053	1712	1883	444	478	777	854
NIH, 2 Pass Cover, 300 psig (2068 kPa)	927	1078	1662	1908	420	489	754	865
NIH, 3 Pass Cover, 300 psig (2068 kPa)	997	1050	1724	1807	452	476	782	820
NIH/MWB End Cover, 300 psig (2068 kPa)	834	834	1378	1378	378	378	625	625

LEGEND

- NIH — Nozzle-in-Head
- MWB — Marine Waterbox
- STD — Standard

NOTE: Weight for NIH 2-pass cover, 150 psig (1034 kPa), is included in the heat exchanger weights shown in the heat exchanger weight tables.

Table 34 — 19XR Waterbox Cover Weights Condenser Frames 6, 7

WATERBOX DESCRIPTION	ENGLISH (LB)				METRIC (KG)			
	CONDENSER				CONDENSER			
	FRAME 6		FRAME 7		FRAME 6		FRAME 7	
	STD NOZZLES	FLANGED	STD NOZZLES	FLANGED	STD NOZZLES	FLANGED	STD NOZZLES	FLANGED
NIH, 1 Pass Cover, 150 psig (1034 kPa)	187	223	329	441	85	101	149	200
NIH, 2 Pass Cover, 150 psig (1034 kPa)	245	330	404	520	111	150	183	236
NIH, 3 Pass Cover, 150 psig (1034 kPa)	772	843	1222	1280	350	382	554	580
MWB End Cover, 150 psig (1034 kPa)	487	487	781	781	221	221	354	354
MWB Return Cover, 150 psig (1034 kPa)	172	172	700	700	78	78	318	318
NIH, 1 Pass Cover, 300 psig (2068 kPa)	978	1053	315	315	444	478	143	143
NIH, 2 Pass Cover, 300 psig (2068 kPa)	923	1074	1690	1851	419	487	767	840
NIH, 3 Pass Cover, 300 psig (2068 kPa)	995	1049	1628	1862	451	476	738	845
NIH/MWB End Cover, 300 psig (2068 kPa)	834	834	1714	1831	378	378	777	831

LEGEND

- NIH — Nozzle-in-Head
- MWB — Marine Waterbox
- STD — Standard

NOTE: Weight for NIH 2-pass cover, 150 psig (1034 kPa), is included in the heat exchanger weights shown in the heat exchanger weight tables.

Table 35 — 19XR Waterbox Cover Weights Cooler Frame 8

WATERBOX DESCRIPTION	ENGLISH (LB)		METRIC (KG)	
	COOLER		COOLER	
	FRAME 8		FRAME 8	
	STD NOZZLES	FLANGED	STD NOZZLES	FLANGED
NIH, 1 Pass Cover, 150 psig (1034 kPa)	417	494	189	224
NIH, 2 Pass Cover, 150 psig (1034 kPa)	540	693	245	314
NIH, 3 Pass Cover, 150 psig (1034 kPa)	1629	1687	739	765
MWB End Cover, 150 psig (1034 kPa)	1125	1125	510	510
MWB Return Cover, 150 psig (1034 kPa)	404	404	183	183
NIH, 1 Pass Cover, 300 psig (2068 kPa)	2359	2523	1070	1144
NIH, 2 Pass Cover, 300 psig (2068 kPa)	2369	2599	1075	1179
NIH, 3 Pass Cover, 300 psig (2068 kPa)	2353	2516	1067	1141
NIH/MWB End Cover, 300 psig (2068 kPa)	1951	1951	885	885

LEGEND

- NIH — Nozzle-in-Head
- MWB — Marine Waterbox
- STD — Standard

NOTE: Weight for NIH 2-pass cover, 150 psig (1034 kPa), is included in the heat exchanger weights shown in the heat exchanger weight tables.

Table 36 — 19XR Waterbox Cover Weights Condenser Frame 8

WATERBOX DESCRIPTION	ENGLISH (LB)		METRIC (KG)	
	CONDENSER		CONDENSER	
	FRAME 8		FRAME 8	
	STD NOZZLES	FLANGED	STD NOZZLES	FLANGED
NIH, 1 Pass Cover, 150 psig (1034 kPa)	417	494	189	224
NIH, 2 Pass Cover, 150 psig (1034 kPa)	508	662	245	314
NIH, 3 Pass Cover, 150 psig (1034 kPa)	1469	1527	739	765
MWB End Cover, 150 psig (1034 kPa)	1007	1007	510	510
MWB Return Cover, 150 psig (1034 kPa)	1307	1307	183	183
NIH, 1 Pass Cover, 300 psig (2068 kPa)	404	404	1070	1144
NIH, 2 Pass Cover, 300 psig (2068 kPa)	1986	2151	1075	1179
NIH, 3 Pass Cover, 300 psig (2068 kPa)	1893	2222	1067	1141
NIH/MWB End Cover, 300 psig (2068 kPa)	1993	2112	885	885

LEGEND

- NIH — Nozzle-in-Head
- MWB — Marine Waterbox
- STD — Standard

NOTE: Weight for NIH 2-pass cover, 150 psig (1034 kPa), is included in the heat exchanger weights shown in the heat exchanger weight tables.

**Table 37 — 19XR Waterbox Cover Weights, Two-Stage Compressor Frame 6
Cooler Frame A**

WATERBOX DESCRIPTION	PASSES	ENGLISH (LB)		METRIC (KG)	
		COOLER		COOLER	
		FRAME A		FRAME A	
		STANDARD NOZZLES	FLANGED	STANDARD NOZZLES	FLANGED
Dished Head, 150 psig	1	1006	1171	456	531
MWB End Cover, 150 psig	1	976	976	443	443
MWB End Cover (ASME), 300 psig	1	2460	2460	1116	1116
Dished Head, 150 psig	2	1140	1336	517	606
Dished Head (Return Cover), 150 psig	2	976	976	443	443
MWB End Cover, 150 psig	2	1068	1068	484	484
MWB End Cover (Return Cover), 150 psig	2	976	976	443	443
MWB End Cover (ASME), 300 psig	2	2460	2460	1116	1116
MWB End Cover (ASME) (Return Cover), 300 psig	2	2460	2460	1116	1116
Dished Head, 150 psig	3	1048	1112	475	504
MWB End Cover, 150 psig	3	1030	1030	467	467
MWB End Cover (ASME), 300 psig	3	2460	2460	1116	1116

LEGEND

ASME — American Society of Mechanical Engineers
MWB — Marine Waterbox

NOTES:

1. Consult factory for 1 and 3 pass data.
2. Weights for dished head cover and MWB end cover 150 psig (1034 kPa) are included in the heat exchanger weights shown in the heat exchanger weight tables.

**Table 38 — 19XR Waterbox Cover Weights, Two-Stage Compressor Frame 6
Condenser Frame A and B**

WATERBOX DESCRIPTION	PASSES	ENGLISH (LB)				METRIC (KG)			
		CONDENSER				CONDENSER			
		FRAME A		FRAME B		FRAME A		FRAME B	
		STANDARD NOZZLES	FLANGED	STANDARD NOZZLES	FLANGED	STANDARD NOZZLES	FLANGED	STANDARD NOZZLES	FLANGED
Dished Head, 150 psig	1	895	1060	1006	1171	406	481	473	547
MWB, 150 psig	1	859	859	1075	1075	390	390	488	488
MWB (ASME), 300 psig	1	2117	2117	2744	2744	960	960	1292	1292
Dished Head, 150 psig	2	981	1179	1140	1400	445	535	574	633
Dished Head (Return Cover), 150 psig	2	824	824	976	976	374	374	481	481
MWB 150 psig	2	907	907	1075	1075	411	411	630	630
MWB (Return), 150 psig	2	824	824	976	976	374	411	488	488
MWB (ASME), 300 psig	2	2117	2117	2744	2744	960	1083	1440	1440
MWB Return Cover (ASME), 300 psig	2	2117	2117	2744	2744	960	960	1245	1245
Dished Head, 150 psig	3	1067	1157	1050	1140	484	525	476	517
MWB End Cover, 150 psig	3	942	942	1020	1020	427	427	463	463
MWB End Cover (ASME), 300 psig	3	2117	2177	2744	2744	960	987	1245	1245

LEGEND

ASME — American Society of Mechanical Engineers
MWB — Marine Waterbox

NOTES:

1. Consult factory for 1 and 3 pass data.
2. Weights for dished head cover and MWB end cover 150 psig (1034 kPa) are included in the heat exchanger weights shown in the heat exchanger weight tables.

**Table 39 — 19XR Waterbox Cover Weights, Two-Stage Compressor Frame 7
Cooler Frames B, C**

WATERBOX DESCRIPTION	PASSES	ENGLISH (LB)				METRIC (KG)			
		COOLER				COOLER			
		FRAME B		FRAME C		FRAME B		FRAME C	
		STD NOZZLES	FLANGED	STD NOZZLES	FLANGED	STD NOZZLES	FLANGED	STD NOZZLES	FLANGED
Dished Head, 150 psig (1034 kPa)	1	1380	1545	1849	2014	626	701	839	914
MWB End Cover, 150 psig (1034 kPa)	1	1366	1366	1835	1835	620	620	832	832
MWB End Cover (ASME), 300 psig (2068 kPa)	1	3425	3425	4805	4805	1554	1554	2180	2180
Dished Head, 150 psig (1034 kPa)	2	1589	1849	2076	2336	721	839	942	1060
Dished Head (Return Cover), 150 psig (1034 kPa)	2	1367	1367	1836	1836	620	620	833	833
MWB End Cover, 150 psig (1034 kPa)	2	1489	1489	1987	1987	675	675	901	901
MWB (Return Cover), 150 psig (1034 kPa)	2	1367	1367	1836	1836	620	620	833	833
MWB End Cover (ASME), 300 psig (2068 kPa)	2	3425	3425	4805	4805	1554	1554	2180	2180
MWB (Return Cover), 300 psig (2068 kPa)	2	3425	3425	4805	4805	1554	1554	2180	2180
Dished Head, 150 psig (1034 kPa)	3	1514	1604	2028	2118	687	728	920	961
MWB End Cover, 150 psig (1034 kPa)	3	1506	1506	1995	1995	683	683	905	905
MWB End Cover (ASME), 300 psig (2068 kPa)	3	3425	3425	4805	4805	1554	1554	2180	2180

LEGEND

ASME — American Society of Mechanical Engineers
MWB — Marine Waterbox
STD — Standard

NOTES:

1. Consult factory for 1 and 3 pass data.
2. Weights for dished head cover and MWB end cover 150 psig (1034 kPa) are included in the heat exchanger weights shown in the heat exchanger weight tables.

**Table 40 — 19XR Waterbox Cover Weights, Two-Stage Compressor Frame 7
Condenser Frames C, D**

WATERBOX DESCRIPTION	PASSES	ENGLISH (LB)				METRIC (KG)			
		CONDENSER				CONDENSER			
		FRAME C		FRAME D		FRAME C		FRAME D	
		STD NOZZLES	FLANGED	STD NOZZLES	FLANGED	STD NOZZLES	FLANGED	STD NOZZLES	FLANGED
Dished Head, 150 psig (1034 kPa)	1	1380	1600	1849	2029	626	726	839	920
MWB End Cover, 150 psig (1034 kPa)	1	1367	1367	1835	1835	620	620	832	832
MWB End Cover (ASME), 300 psig (2068 kPa)	1	3639	3639	5249	5249	1651	1651	2353	2353
Dished Head, 150 psig (1034 kPa)	2	1589	1919	2076	2406	721	870	942	1091
Dished Head (Return Cover), 150 psig (1034 kPa)	2	1367	1367	1836	1836	620	620	833	833
MWB End Cover, 150 psig (1034 kPa)	2	1497	1497	1988	1988	679	679	902	902
MWB (Return Cover), 150 psig (1034 kPa)	2	1367	1367	1836	1836	620	620	833	833
MWB End Cover (ASME), 300 psig (2068 kPa)	2	3639	3639	5249	5249	1651	1651	2381	2381
MWB (Return Cover) (ASME), 300 psig (2068 kPa)	2	3639	3639	5249	5249	1651	1651	2381	2381
Dished Head, 150 psig (1034 kPa)	3	1514	1612	2028	2126	687	731	920	964
MWB End Cover, 150 psig (1034 kPa)	3	1493	1493	1993	1993	677	677	904	904
MWB End Cover (ASME), 300 psig (2068 kPa)	3	3639	3639	5249	5249	1651	1651	2381	2381

LEGEND

ASME — American Society of Mechanical Engineers
MWB — Marine Waterbox
STD — Standard

NOTES:

1. Consult factory for 1 and 3 pass data.
2. Weights for dished head cover and MWB end cover 150 psig (1034 kPa) are included in the heat exchanger weights shown in the heat exchanger weight tables.

Table 41 — 19XR2-E Component Weights

COMPONENT	FRAME 2 COMPRESSOR*		FRAME 3 COMPRESSOR*		FRAME 4 COMPRESSOR*		FRAME 5 COMPRESSOR*		FRAME C COMPRESSOR		FRAME E COMPRESSOR	
	lb	kg	lb	kg	lb	kg	lb	kg	lb	kg	lb	kg
SUCTION ELBOW	116	53	185	84	239	108	407	185	303	137	337	171
DISCHARGE ELBOW	100	45	125	57	157	71	325	147	245	111	427	194
CONTROL PANEL†	92	72	92	72	92	72	92	72	92	42	92	42
OPTIONAL COOLER INLET ISOLATION VALVE	8	4	13	6	20	9	24	11	24	11	24	11
OPTIONAL DISCHARGE ISOLATION VALVE	26	12	46	21	74	34	108	49	93	42	93	42
STD TIER VFD — 380, 400, AND 460-V (230, 335, 445 A)	650	295	650	295	—	—	—	—	650	295	—	—
STD TIER VFD — 380, 400, AND 460-V (DD588)	—	—	275	125	275	125	—	—	275	125	—	—
STD TIER VFD — 380, 400, AND 460-V (DE658, DE745, DE800)	—	—	650	295	650	295	—	—	650	295	—	—
STD TIER VFD — 380, 400, AND 460-V (DE800, DE990)	—	—	—	—	700	318	700	318	700	318	700	318
STD TIER VFD — 380, 400, AND 460-V (DP1120, DP1260, DP1460)	—	—	—	—	3000	1361	3000	1361	3000	1361	3000	1361
STD TIER VFD — 380, 400, AND 460-V (DP1670)	—	—	—	—	—	—	3400	1542			3400	1542
LIQUIFLO™ 2 VFD — 380, 400, AND 460-V (442 A)	1600	726	1600	726	—	—	—	—	—	—	—	—
LIQUIFLO 2 VFD — 380, 400, AND 460-V (608 A)	—	—	1600	726	1600	726	—	—	—	—	—	—
LIQUIFLO 2 VFD — 380, 400, AND 460-V (900 A)	—	—	—	—	2800	1270	2800	1270	2800	1270	2800	1270
LIQUIFLO 2 VFD — 380, 400, AND 460-V (1200 A)	—	—	—	—	2850	1293	2850	1293	2850	1293	2850	1293
LIQUIFLO 2 VFD — 575-V (390 A)	2200	998	2200	998	—	—	—	—	—	—	—	—
VFD SHELF (ROCKWELL VFD)	—	—	—	—	1049	476	1049	476	1049	476	1049	476
VFD SHELF (DANFOSS VFD)			1395	633	1395	633	1499	680	1395	633	1499	680

* To determine compressor frame size, refer to 19XR,XRV Computer Selection Program.

† Included in total cooler weight.

NOTES

1. VFD sizes are available on select heat exchanger models; consult the 19XR,XRV Computer Selection program.
2. VFD Power Panel (DD558, DE658, DE745, DE800, DE880, DE990) used on frames 3, 4, C, 5, E = 300 lbs (136 kg).

Table 42 — 19XR6-7 Component Weights

COMPONENT	FRAME 6 COMPRESSOR		FRAME 7 COMPRESSOR	
	lb	kg	lb	kg
TRANSMISSION ASSEMBLY (INCLUDING BULL GEAR, HIGH SPEED SHAFT, STATOR, ROTOR, MOTOR END COVER)	11,243	5100	13,481	6115
BULL GEAR	121	55	220	100
HIGH SPEED SHAFT ASSEMBLY	523	237	700	318
SUCTION ASSEMBLY (INCLUDING BLADE RING)	1520	689	2125	964
BLADE RING ASSEMBLY	109	49	384	174
COMPRESSOR BASE	5450	2472	7898	3582
MOTOR END COVER	1021	463	1072	486
INTAKE WALL	220	100	959	435
DISCHARGE WALL	172	78	296	134
DIAPHRAGM	700	318	820	372
OIL PUMP	124	56	124	56
TOTAL WEIGHT (INCLUDING MAX MOTOR STATOR, ROTOR, MOTOR END COVER)	19,657	8916	25,983	11,786

Table 43 — 19XR Compressor Frame 2 Through Frame 5 Fits and Clearances (in.)

ITEM	COMPRESSOR	FRAME 2	FRAME 3	FRAME 4		FRAME 5	
	Code	201-299, 2ZZ	321-389, 3ZZ, 32E-38H	421-487, 4B1-4W7		501-599	
	DESCRIPTION	Oil Film Bearings	Rolling Element Bearings	Oil Film Bearings	Rolling Element Bearings	Oil Film Bearings	Rolling Element Bearings
A	Low Speed Journal-Gear End	.0050/.0040	.0050/.0040	.0055/.0043	.0055/.0043	.0069/.0059	.0069/.0059
B	Low Speed Journal-Motor End	.0050/.0040	.0050/.0040	.0053/.0043	.0053/.0043	.0065/.0055	.0065/.0055
C1	Low Speed Labyrinth to Thrust Disk	.0115/.0055	N/A	.010/.005	N/A	N/A	N/A
C2	Labyrinth to Low Speed Shaft	N/A	.010/.005	.0095/.0055	.0095/.0055	.013/.009	.013/.009
D	Low Speed Shaft Thrust Float	.020/.008	.020/.008	.023/.008	.023/.008	.020/.008	.020/.008
E	Impeller Eye to Shroud	*	*	*	*	*	*
F1	Impeller Bore to Shaft-Rear	-.0020/-.0005	-.0025/-.0010	-.0014/-.0029	-.0014/-.0029	-.0019/-.0005	-.0019/-.0005
F2	Impeller Bore to Shaft-Front	N/A	N/A	-.0005/-.0025	-.0005/-.0025	-.0014/.0000	N/A
G	Impeller Discharge to Shroud	*	*	*	*	*	*
H	Impeller Spacer to Shaft	.0025/.0010	.0025/.0010	.0025/.0010	.0025/.0010	.0024/.0010	.0024/.0010
I	Slinger to Shaft	.0013/.0005	.0012/.0004	.0012/.0004	.0012/.0004	.0012/.0004	.0012/.0004
J	Labyrinth to Slinger	.013/.009	.010/.006	.010/.006	.010/.006	.010/.006	.010/.006
K	Labyrinth to Impeller	.012/.008	.012/.008	.012/.008	.012/.008	.012/.008	.012/.008
L	High Speed Journal-Impeller End	.0047/.0037	N/A	.0040/.0028	N/A	.0048/.0038	N/A
M	Thrust Assembly Seal Ring Axial Clearance	.006/.002	N/A	.006/.002	N/A	.006/.002	N/A
N	Thrust Assembly Seal Ring to Shaft	.0045/.0015	N/A	.0045/.0015	N/A	.0045/.0015	N/A
O	High Speed Shaft Thrust Float	.014/.008	0 Float	.014/.008	Float	.014/.008	0 Float
P	High Speed Journal-Gear End	.0050/.0040	N/A	.0048/.0038	N/A	.0062/.0052	N/A

* Depends on impeller size, contact your Carrier Service Representative for more information.

NOTES:

1. All clearances for cylindrical surfaces are diametrical.
2. Dimensions shown are with rotors in the thrust position.
3. Frame 3 rolling element style high speed shaft and bearing assembly cannot be pulled from impeller end. The transmission assembly must be removed from the compressor casting (after the impeller is

- removed) and the bearing temperature sensor must be removed from the high speed shaft and bearing assembly before the high speed shaft and bearing assembly can be separated from the transmission.
4. If any components within a rolling element high speed shaft and bearing assembly are damaged it is recommended that the entire high speed shaft and bearing assembly be replaced.
5. Impeller spacing should be performed in accordance with the most recent Carrier Impeller Spacing Service Bulletin.

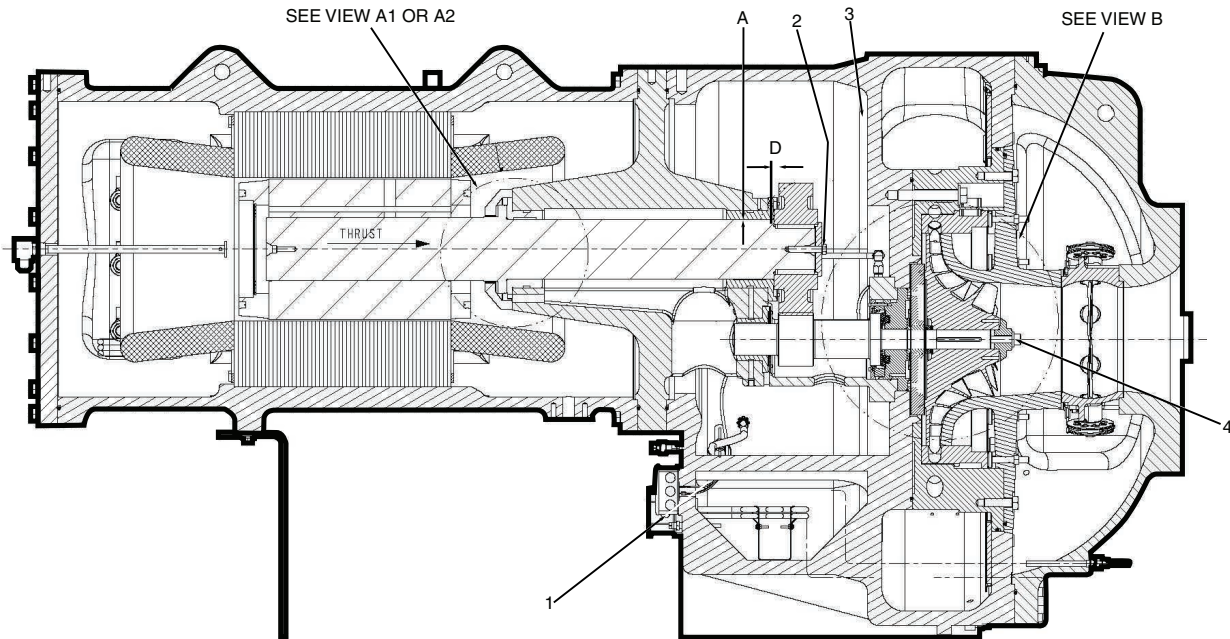

COMPRESSOR, TRANSMISSION AREA (FRAME 5 COMPRESSOR SHOWN)
 1) OIL HEATER RETAINING NUT (NOT SHOWN)
 2) BULL GEAR RETAINING BOLT
 3) DEMISTER BOLTS (NOT SHOWN)
 4) IMPELLER BOLT

COMPRESSOR, TRANSMISSION AREA (FRAME 5 COMPRESSOR SHOWN)

Fig. 53 — Compressor Fits and Clearances — Single-Stage Compressors

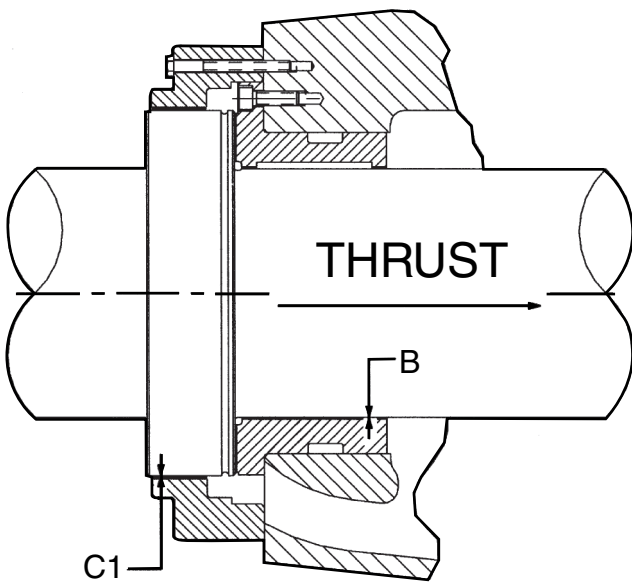

VIEW A1
LOW SPEED SHAFT THRUST DISK
FRAME 2 COMPRESSORS

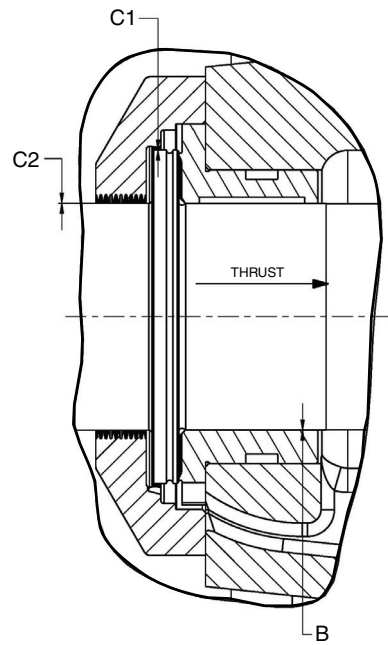

VIEW A2
LOW SPEED SHAFT THRUST DISK
FRAME 3, 4, AND 5 COMPRESSORS

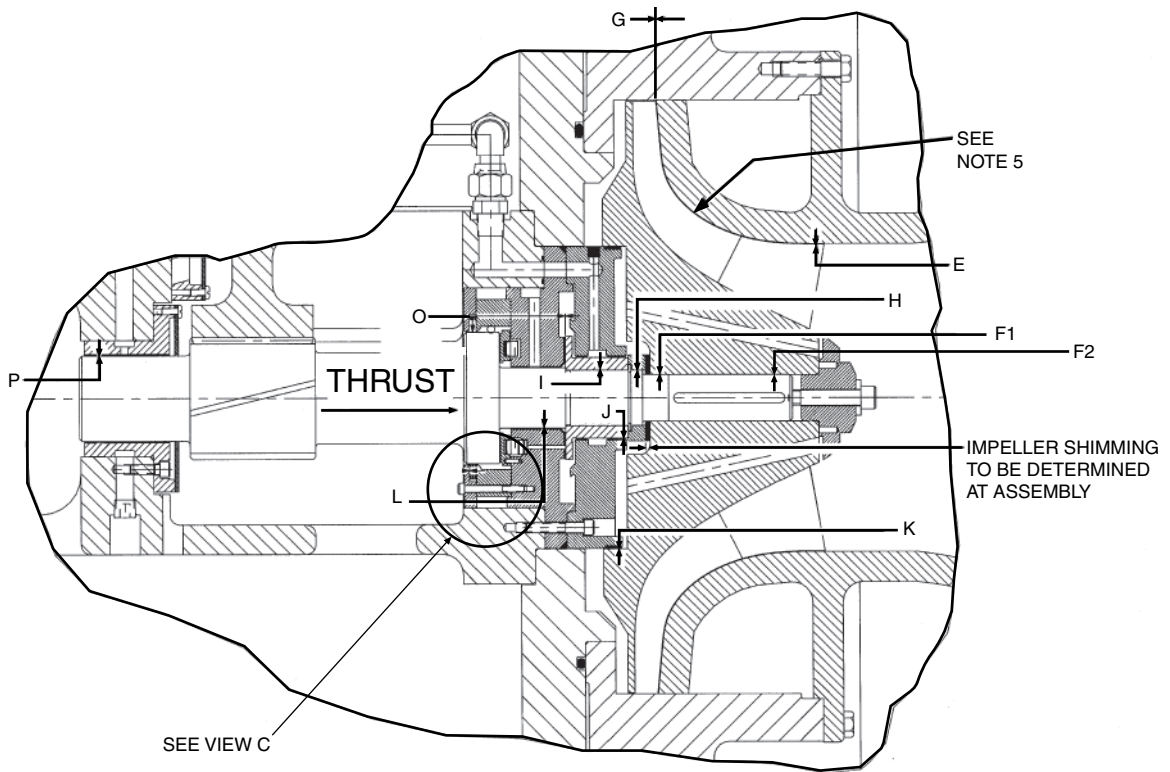

VIEW B — HIGH SPEED SHAFT, ORIGINAL DESIGN (OIL FILM BEARINGS) AND IMPELLER SECTION

Fig. 53 — Compressor Fits and Clearances — Single-Stage Compressors (cont)

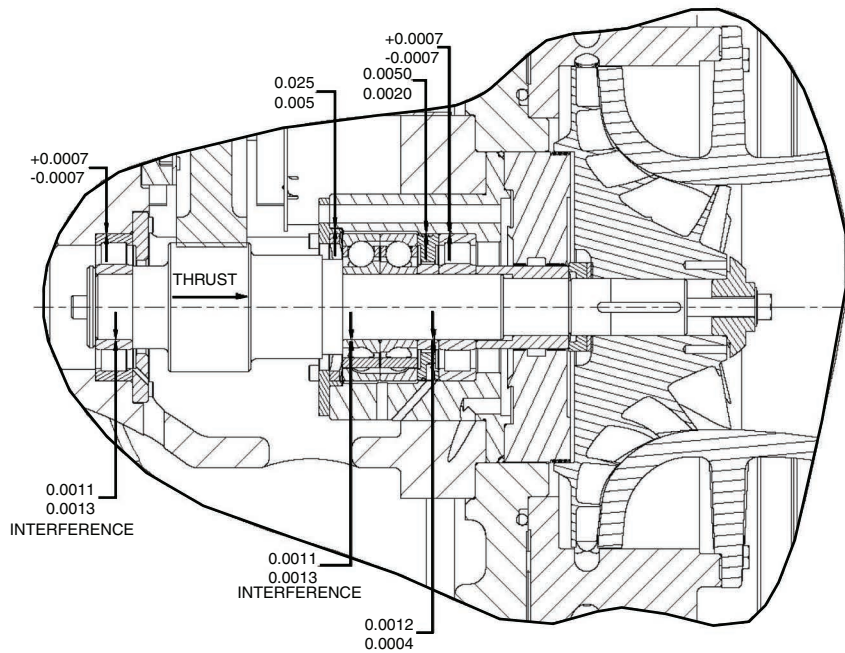

VIEW B — HIGH SPEED SHAFT WITH ROLLING ELEMENT BEARINGS

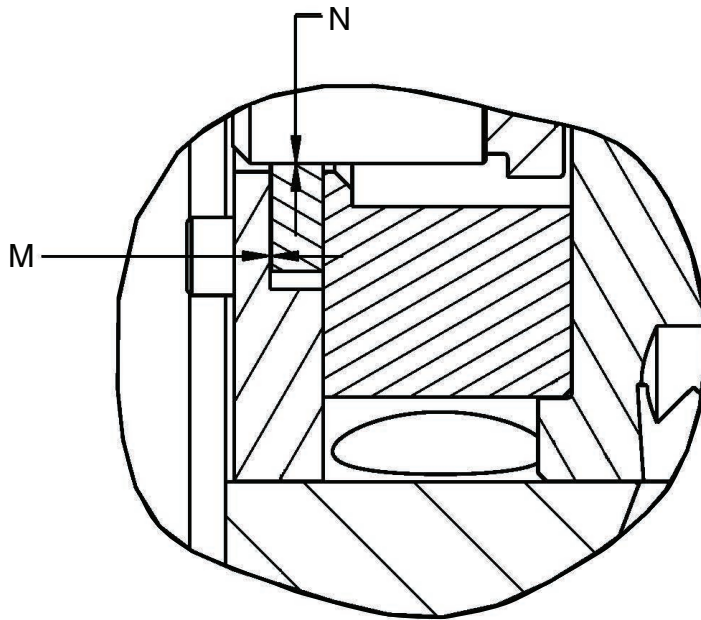

VIEW C — HIGH SPEED SHAFT RING SEAL

Fig. 53 — Compressor Fits and Clearances — Single-Stage Compressors (cont)

Table 44 — 19XR Compressor Frame C, E Fits and Clearances

ITEM	COMPRESSOR	FRAME C	FRAME E
	CODE	C21-C09	E21-E69
	DESCRIPTION	ROLLING ELEMENT BEARINGS	ROLLING ELEMENT BEARINGS
A	Low Speed Journal - Gear End	0.0055/0.0043	0.0069/0.0059
B	Low Speed Journal - Motor End	0.0053/0.0043	0.0065/0.0055
C1	Low Speed Labyrinth to Thrust Disk	0.03/0.0010	N/A
C2	Labyrinth to Low Speed Shaft	0.010/0.005	0.013/0.009
D	Low Speed Shaft Thrust Float	0.023/0.008	0.020/0.008

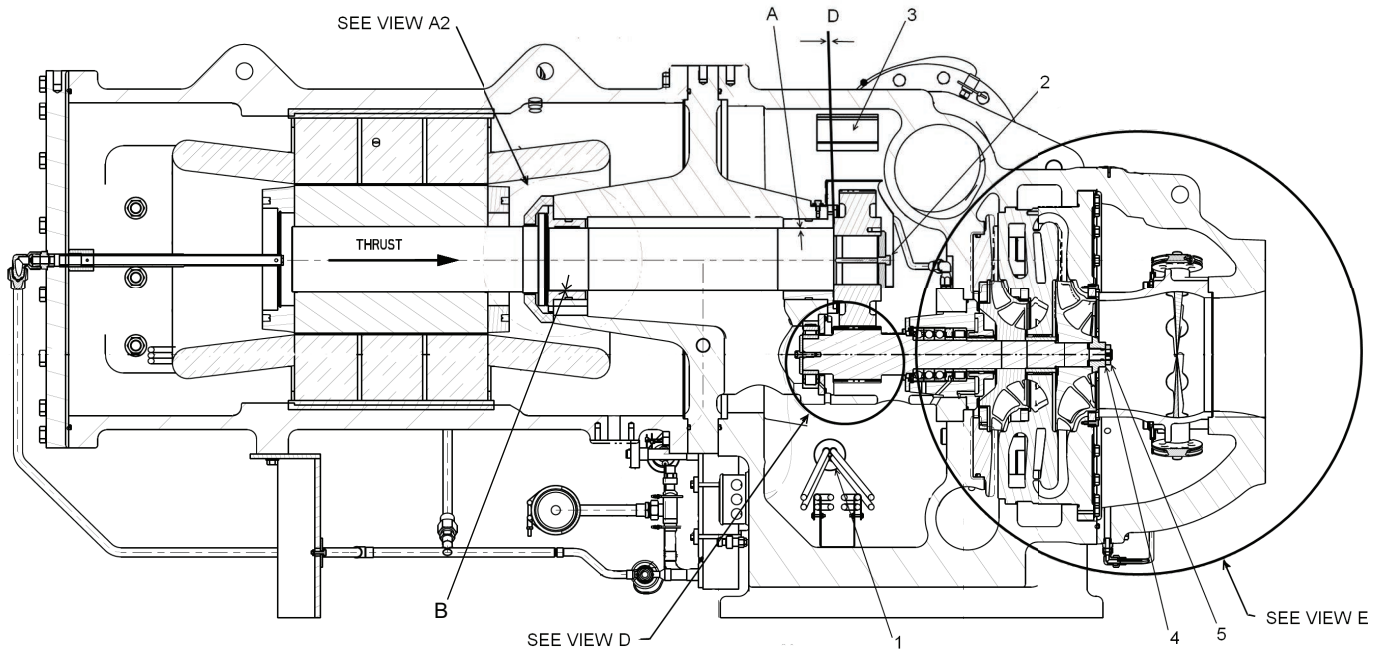

LEGEND

- 1 — Oil Heater Retaining Nut
- 2 — Bull Gear Retaining Bolt
- 3 — Demister Bolts
- 4 — First Impeller Nut (Inner)
- 5 — Second Impeller Nut (Outer)
- 6 — Guide Vane Shaft Seal (Not Shown)

Fig. 54 — 19XR C,E Compressor Fits and Clearances — Two-Stage Compressors

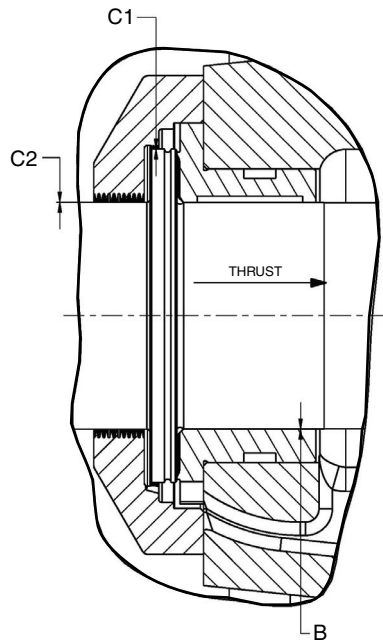

VIEW A2
LOW SPEED SHAFT THRUST DISK

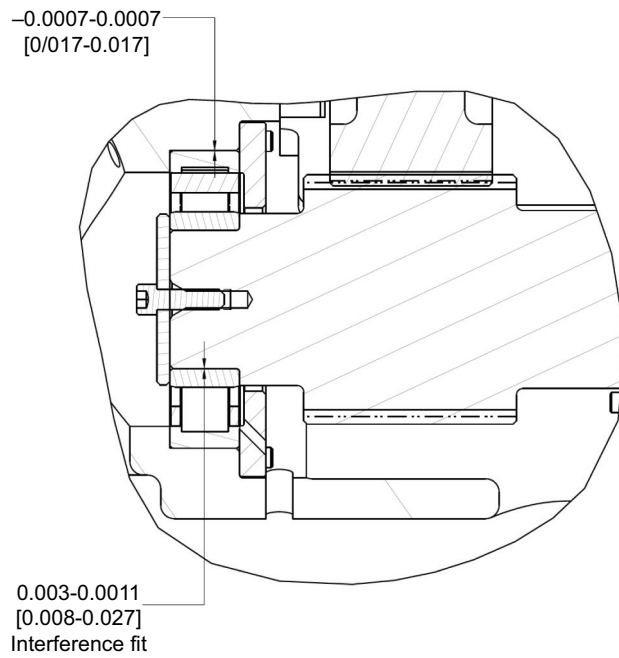

VIEW D
REAR, HIGH SPEED SHAFT BEARING

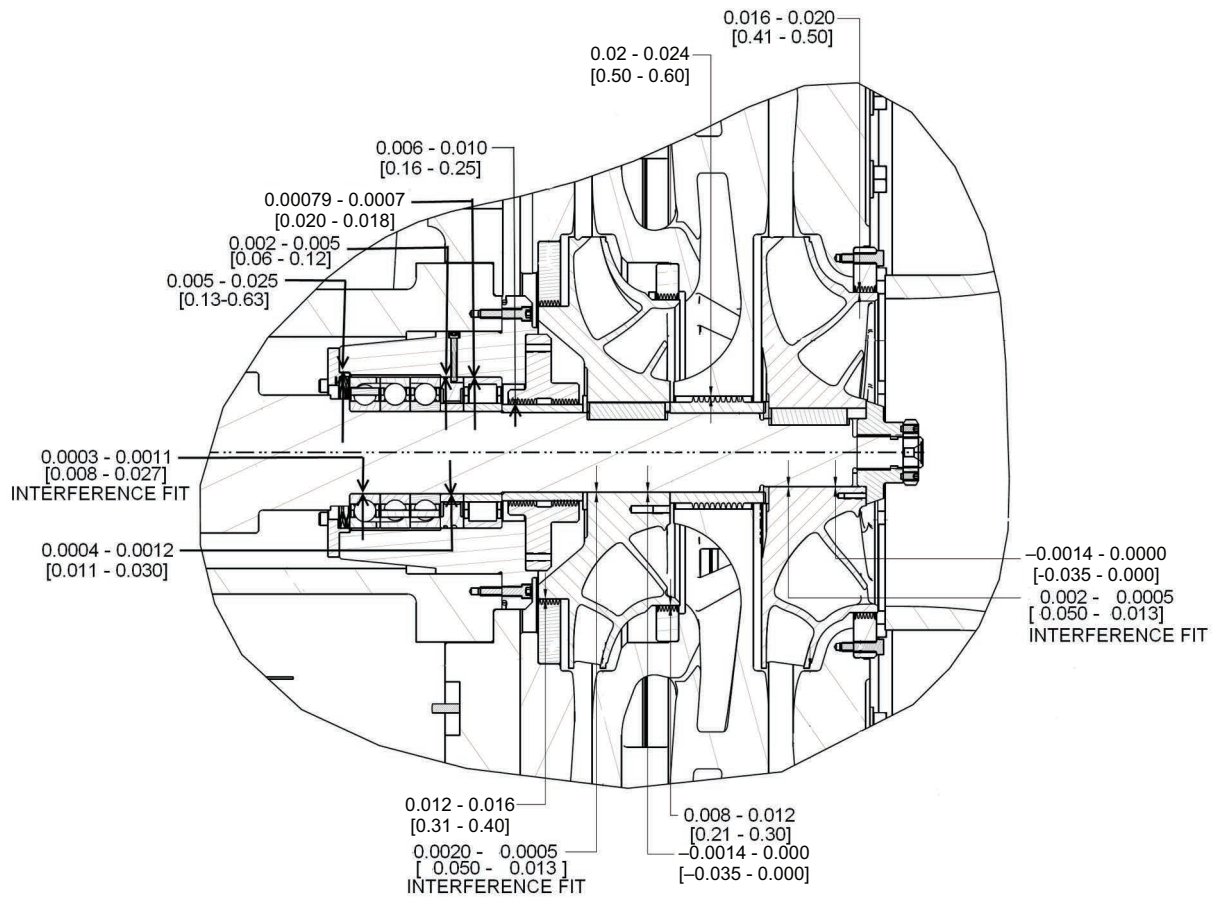

VIEW E

Fig. 54 — 19XR C,E Compressor Fits and Clearances — Two-Stage Compressors (cont)

Table 45 — 19XR Two-stage Compressor Frames 6 and 7 Fits and Clearances

ITEM	COMPRESSOR	FRAME 6 (in.)	FRAME 6 (mm)	FRAME 7 (in.)	FRAME 7 (mm)
	DESCRIPTION				
A	Low Speed Journal — Compressor End	0.006/0.007	0.15/0.18	0.006/0.008	0.15/0.19
B	Low Speed Journal — Motor End	0.004/0.005	0.10/0.11	0.004/0.006	0.10/0.15
C	Low Speed Labyrinth — Compressor End	0.009/0.013	0.23/0.32	0.009/0.013	0.23/0.33
D	Low Speed Shaft Thrust Float	0.008/0.020	0.20/0.50	0.008/0.020	0.20/0.50
E	Impeller Bore to Shaft — 1st Impeller	-0.002/0.000	-0.05/0.01	-0.002/0.000	-0.05/-0.01
F	Impeller Bore to Shaft — 2nd Impeller	-0.002/0.000	-0.06/0.01	-0.002/0.000	-0.05/-0.01
G	Low Speed Bearing Labyrinth to Shaft — Motor End	0.009/0.013	0.23/0.33	0.010/0.012	0.25/0.30
H	Low Speed Bearing to Cover Assembly	0.002/0.004	0.04/0.10	0.001/0.003	0.03/0.08
I	Bull Gear to Low Speed Shaft	-0.001/0.000	-0.03/0.00	-0.0013/0.0000	-0.033/0.000
J	High Speed Shaft Labyrinth to High Speed Labyrinth Sleeve	0.006/0.009	0.15/0.23	0.006/0.009	0.15/0.23
K	Balance Piston Labyrinth to 2nd Stage Impeller	0.008/0.012	0.20/0.30	0.008/0.012	0.20/0.30
L	2nd Stage Eye Labyrinth to Impeller	0.008/0.012	0.20/0.30	0.012/0.016	0.30/0.40
M	Interstage Labyrinth Spacer to High Speed Shaft	0.001/0.002	0.02/0.05	0.001/0.003	0.04/0.07
N	Interstage Labyrinth Seal	0.011/0.017	0.29/0.42	0.009/0.012	0.23/0.30
O	1st Stage Eye Labyrinth to Impeller	0.016/0.020	0.41/0.50	0.024/0.028	0.62/0.72

NOTES:

1. All clearances for cylindrical surfaces are diametrical.
2. Dimensions shown are with rotors in the thrust position.
3. If any components within a rolling element high speed shaft and bearing assembly are damaged it is recommended that the entire high speed shaft and bearing assembly be replaced.

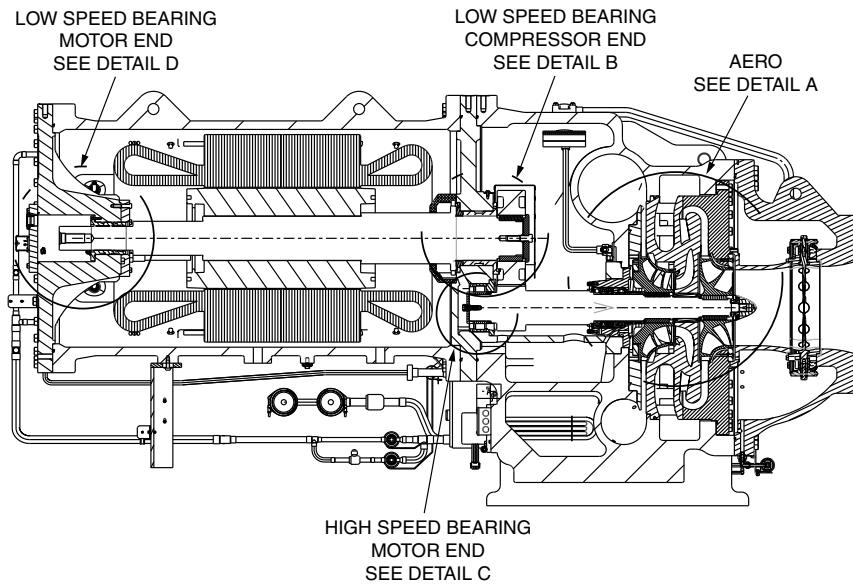

Fig. 55 — Compressor Fits and Clearances — Two-Stage Compressor, Frame Sizes 6 and 7

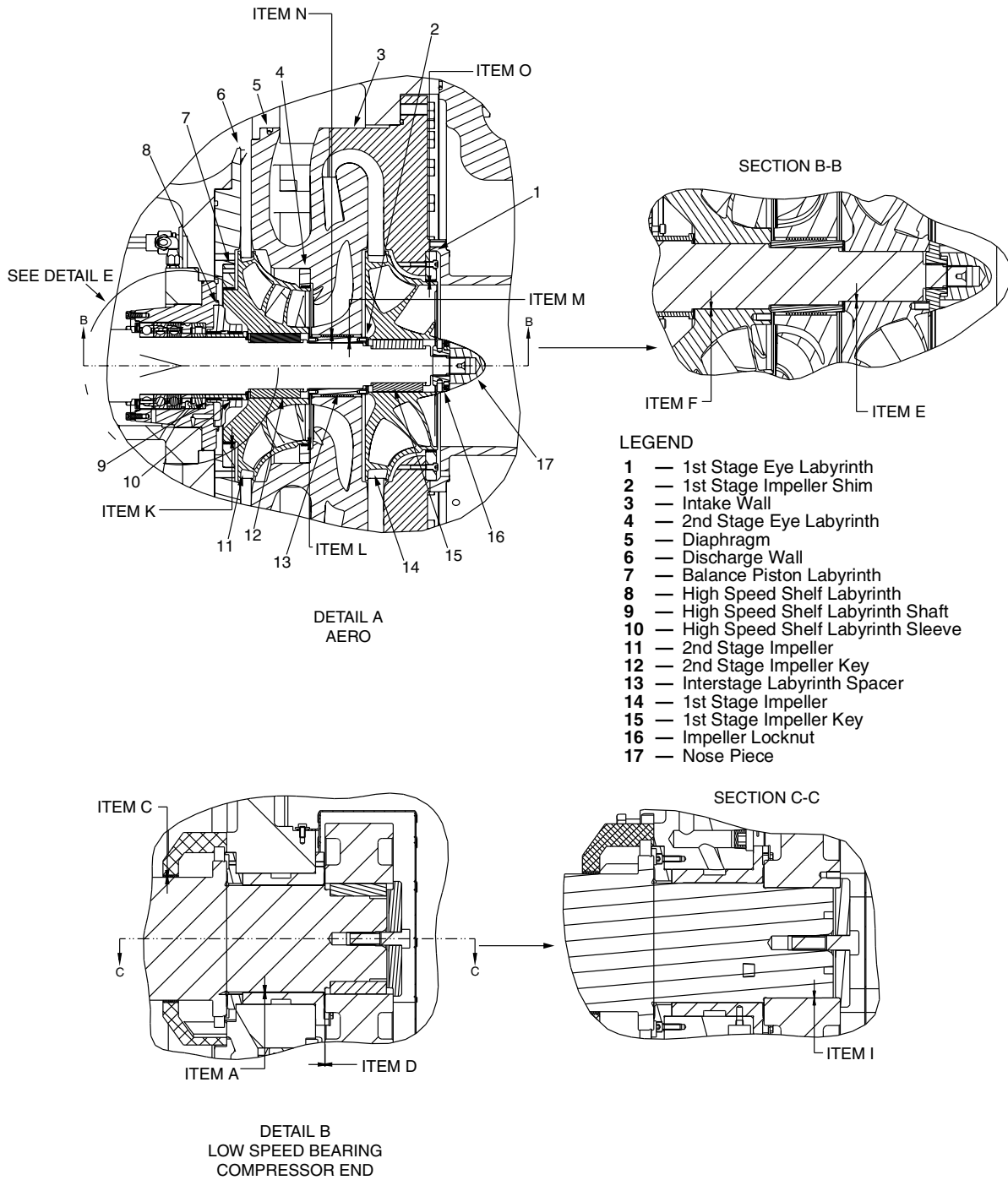
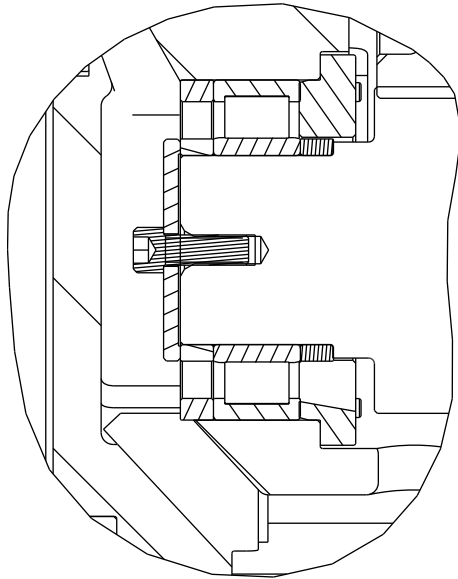
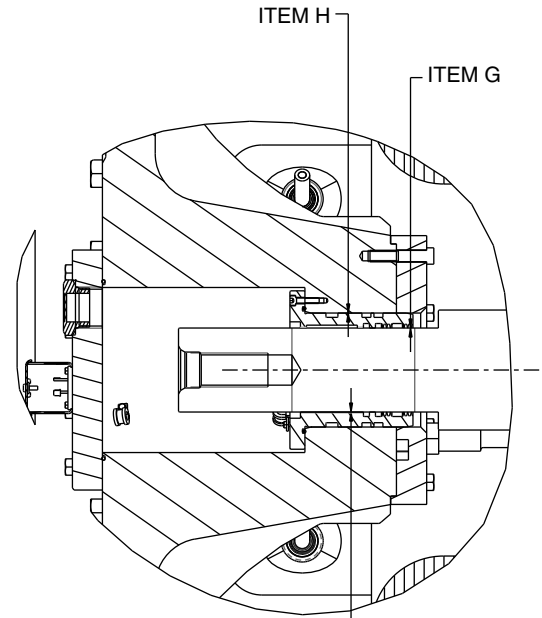

Fig. 55 — Compressor Fits and Clearances — Two-Stage Compressor, Frames Size 6 and 7 (cont)



DETAIL C
HIGH SPEED BEARING
MOTOR END



DETAIL D
LOW SPEED BEARING
MOTOR END

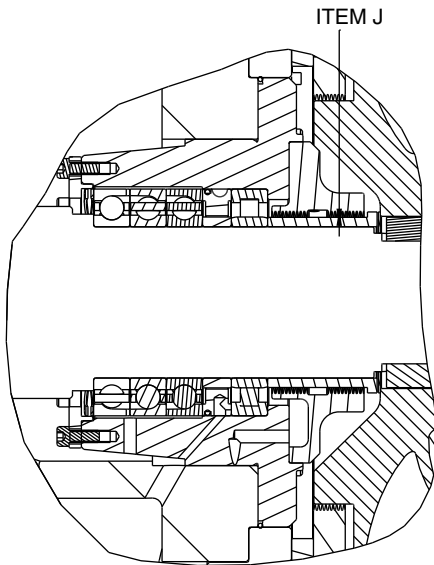

DETAIL E
HIGH SPEED BEARING
COMPRESSOR END (XR6 SHOWN)

Fig. 55 — Compressor Fits and Clearances — Two-Stage Compressor, Frame Sizes 6 and 7 (cont)

⚠ CAUTION

**USE COPPER CONDUCTORS ONLY
UTILISEZ DES CONDUCTEURS EN CUIVRE SEULMENT**

ALWAYS USE 2 WRENCHES TO TIGHTEN

- TERM INSULATOR TO MOTOR – 15-35 ft. lb.
- BRASS NUT TO TERM INSULATOR – 3 ft. lb. max
- ADAPTOR TO TERM STUD – 20-35 ft. lb.
- LUG BOLTS (1/2")– 32-45 ft. lb.

Insulate entire connection with electrical insulation including 1 inch of cable insulation and 1 inch of the term insulator.

13

⚠ CAUTION

**USE COPPER CONDUCTORS ONLY
UTILISEZ DES CONDUCTEURS EN CUIVRE SEULMENT**

ALWAYS USE 2 WRENCHES TO TIGHTEN

- TERM INSULATOR TO MOTOR – 15-35 ft. lb.
- CABLE LUG NUT – 40-45 ft. lb.

Insulate entire connection with electrical insulation including 1 inch of cable insulation and 1 inch of the term insulator.

12

Mandatory for medium/high voltage.

MOTOR LEAD INSTALLATION LABELS

19XRV COMPRESSOR ASSEMBLY TORQUES

ITEM	COMPRESSOR	FRAME 2	FRAME 3	FRAME 4	FRAME 4	FRAME 5
	CODE	201-299, 2ZZ	321-389, 3ZZ, 32E-38H	421-487	4B1-4W7	501-599
	DESCRIPTION	FIXED DIFFUSER	WITH ROLLING ELEMENT BEARINGS	FIXED DIFFUSER	SPLIT RING DIFFUSER	SPLIT RING DIFFUSER
1	Oil Heater Retaining Nut — ft-lb (N-m)	N/A	18-22 (25-30)	18-22 (25-30)	18-22 (25-30)	18-22 (25-30)
2	Bull Gear Retaining Bolt — ft-lb (N-m)	80-90 (108-122)	80-90 (108-122)	80-90 (108-122)	80-90 (108-122)	80-90 (108-122)
3	Demister Bolts — ft-lb (N-m)	15-19 (20-26)	15-19 (20-26)	15-19 (20-26)	15-19 (20-26)	15-19 (20-26)
4	Impeller Bolt Torque — ft-lb (N-m)	32-48 (43-65)	55-60 (75-81)	55-60 (75-81)	55-60 (75-81)	160-225 (217-305)

19XRV COMPRESSOR ASSEMBLY TORQUES FRAME C, E

ITEM	COMPRESSOR	FRAME C	FRAME E
	CODE	C21-C89	E31-E69
1	Oil Heater Retaining Nut — ft-lb (N-m)	18-22 (24-30)	18-22 (24-30)
2	Bull Gear Retaining Bolt — ft-lb (N-m)	80-90 (108-122)	80-90 (108-122)
3	Demister Bolts — ft-lb (N-m)	15-19 (20-26)	15-19 (20-26)
4	Impeller Nut (Inner) — ft-lb (N-m)	100 (136)	250 (339)
5	Impeller Nut (Outer) — ft-lb (N-m)	100 (136)	100 (136)
6	Guide Vane Shaft Seal Nut — ft-lb (N-m)	25 (34)	25 (34)

Fig. 56 — 19XRV Compressor Assembly Torques — Single and Two-Stage Compressors

⚠ CAUTION

USE COPPER CONDUCTORS ONLY
UTILISEZ DES CONDUCTEURS EN CUIVRE SEULMENT

ALWAYS USE 2 WRENCHES TO TIGHTEN

- TERM INSULATOR TO MOTOR – 15-35 ft. lb.
- BRASS NUT TO TERM INSULATOR – 3 ft. lb. max
- ADAPTOR TO TERM STUD – 20-35 ft. lb.
- LUG BOLTS (1/2") – 32-45 ft. lb.

Insulate entire connection with electrical insulation including 1 inch of cable insulation and 1 inch of the term insulator.

13

Mandatory for medium/high voltage.

MOTOR LEAD INSTALLATION LABEL

19XR TWO-STAGE COMPRESSOR ASSEMBLY TORQUES

COMPRESSOR	FRAME 6	FRAME 7
Oil Heater Retaining Nut — ft-lb (N·m)	40-60 (54-81)	40-60 (54-81)
Bull Gear Retaining Bolt — ft-lb (N·m)	72-88 (98-119)	72-88 (98-119)
Demister Bolts — ft-lb (N·m)	15-19 (20-26)	15-19 (20-26)
Impeller Nut (Inner Locknut) — ft-lb (N·m)	243-257 (329-348)	243-257 (329-348)
Impeller Nut (Outer) — ft-lb (N·m)	95-105 (129-142)	95-105 (129-142)
Guide Vane Shaft Seal Nut/Bolts — ft-lb (N·m)	23-27 (31-37)	48-70 (64-94)

Fig. 57 — Compressor Assembly Torques — 19XR Two-Stage Compressors Frame Sizes 6 and 7

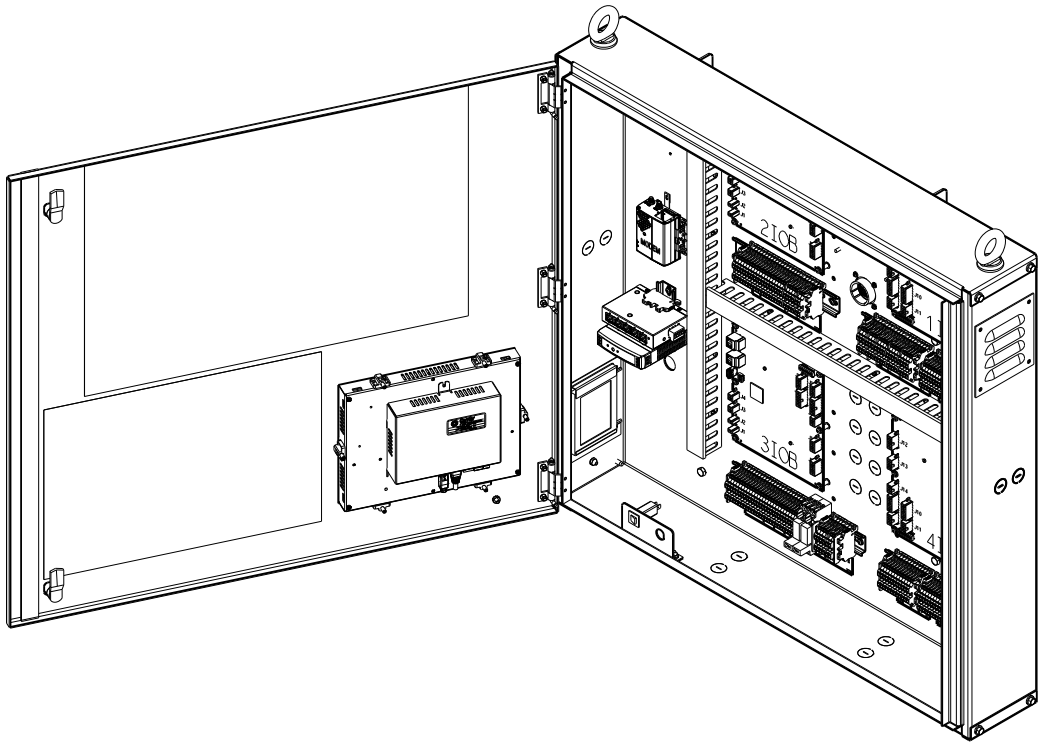

Fig. 58 — 19XR2-E Control Panel

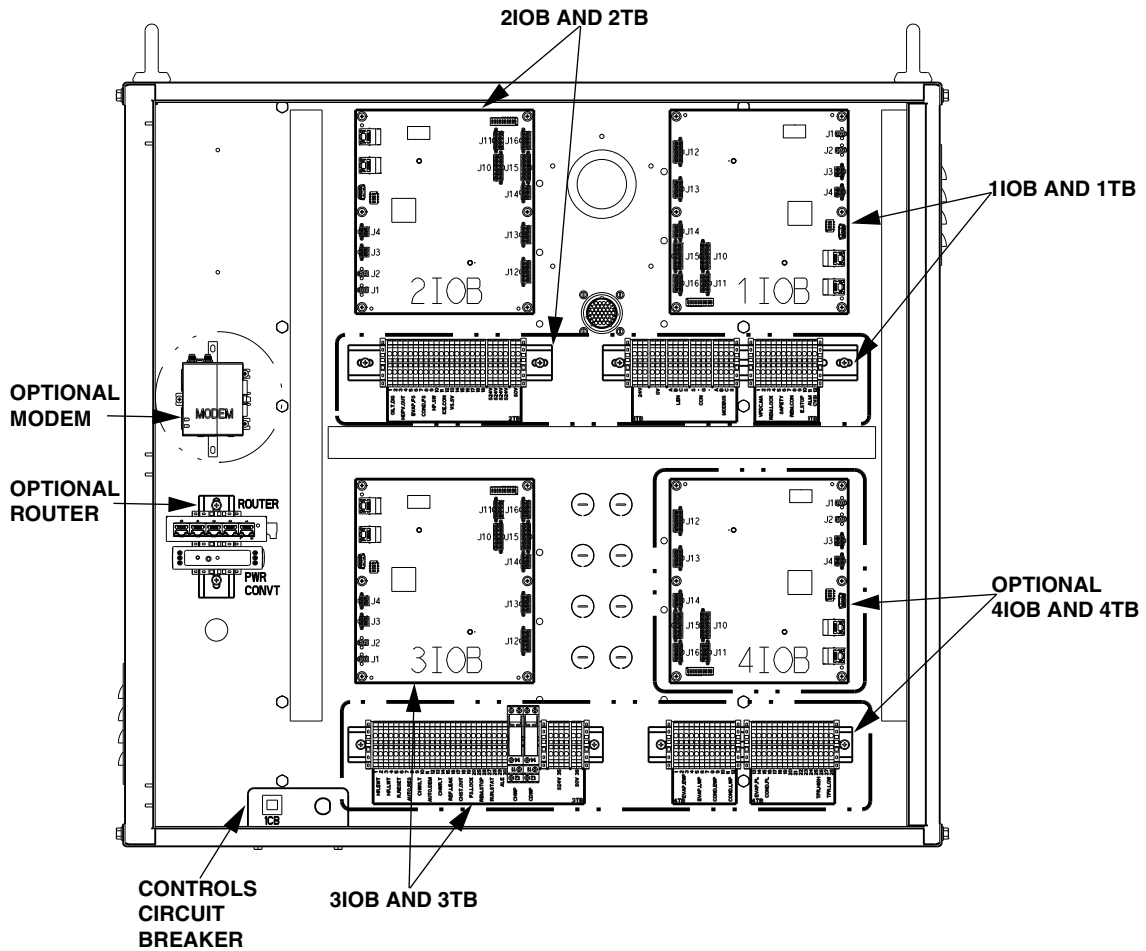

Fig. 59 — 19XR2-E Control Panel, IOB Layer

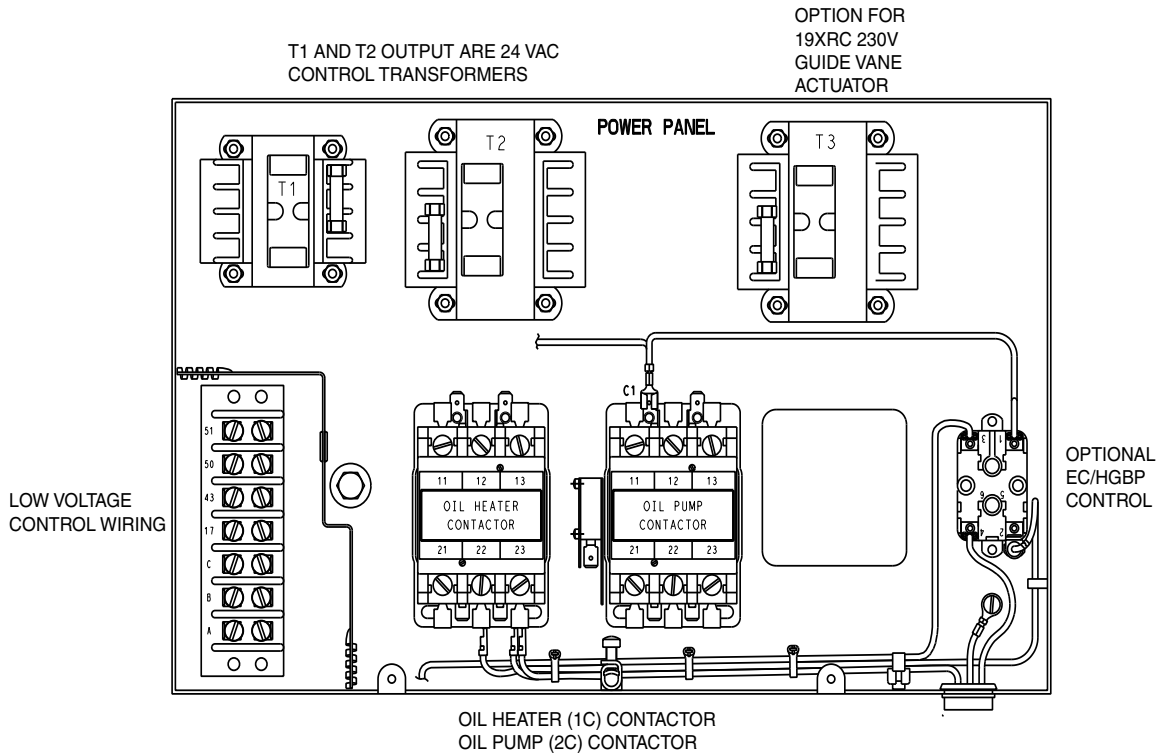

Fig. 60 — 19XR2-E Power Panel

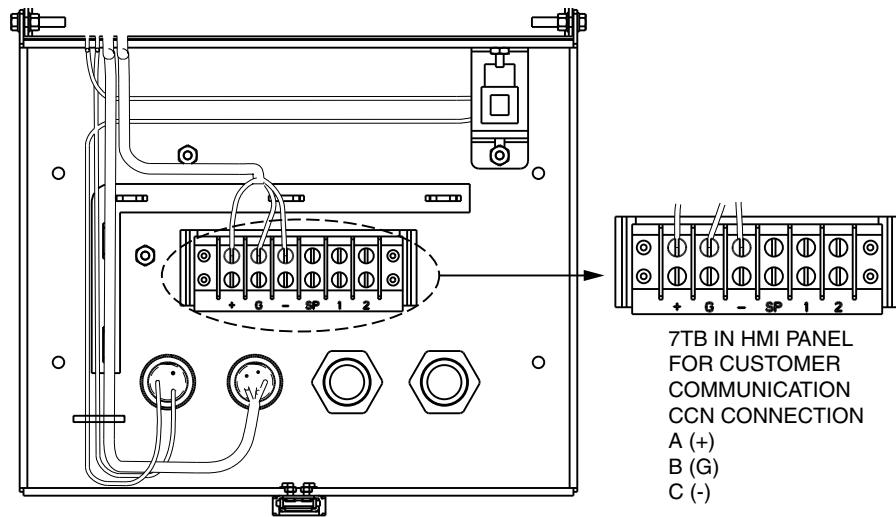

Fig. 61 — 19XR6-7 HMI Panel

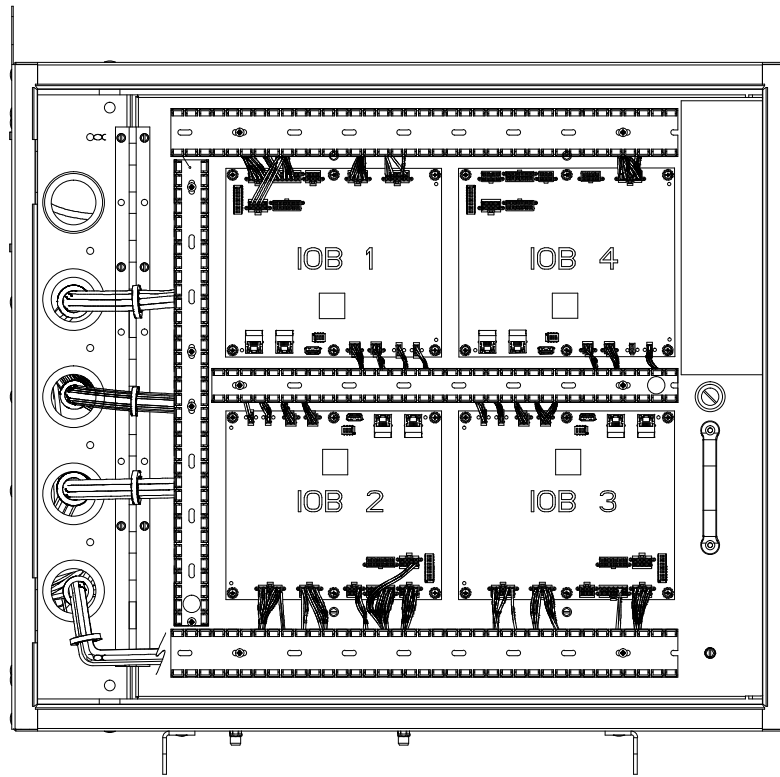

Fig. 62 — 19XR6-7 Control Panel, IOB Layer

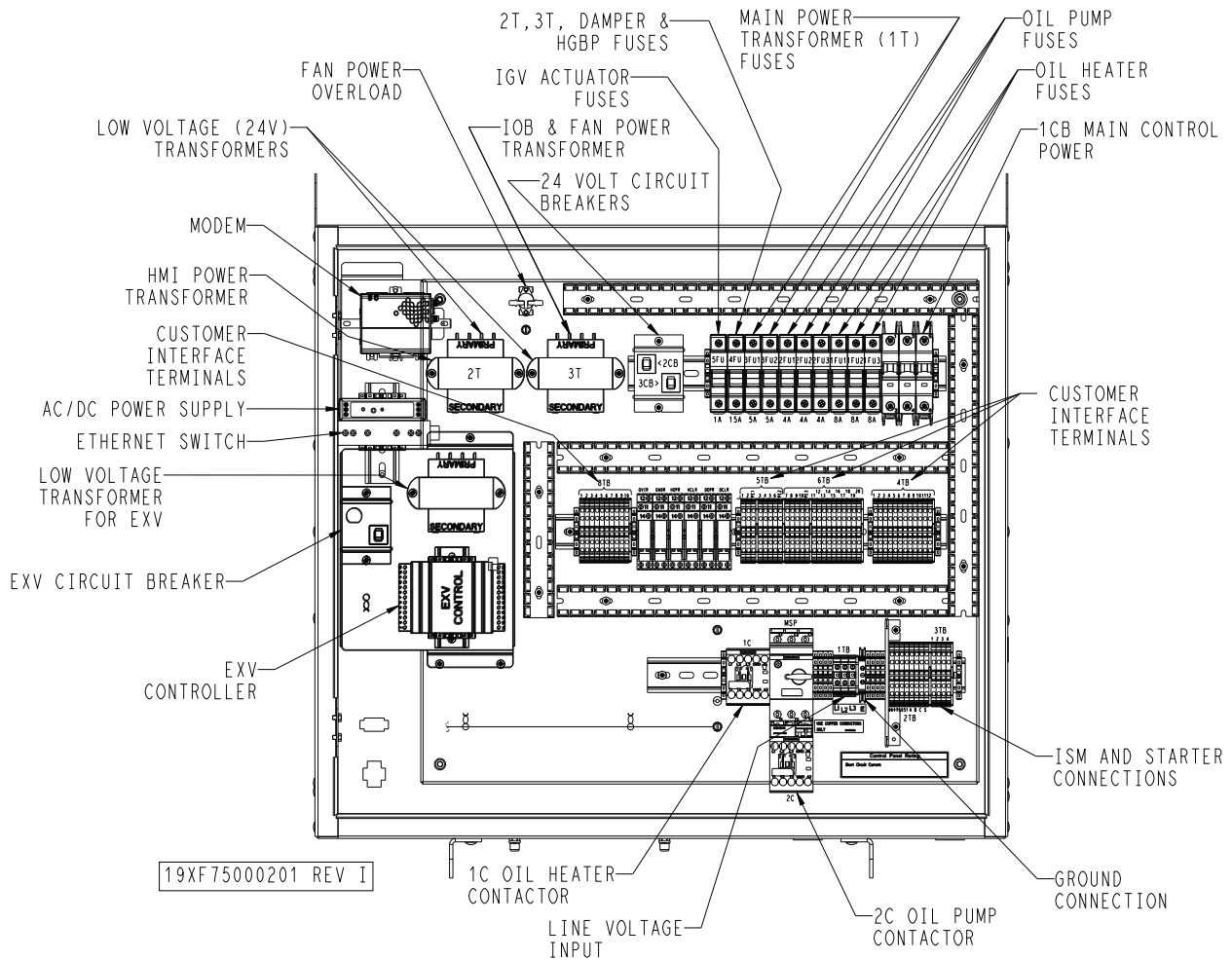



















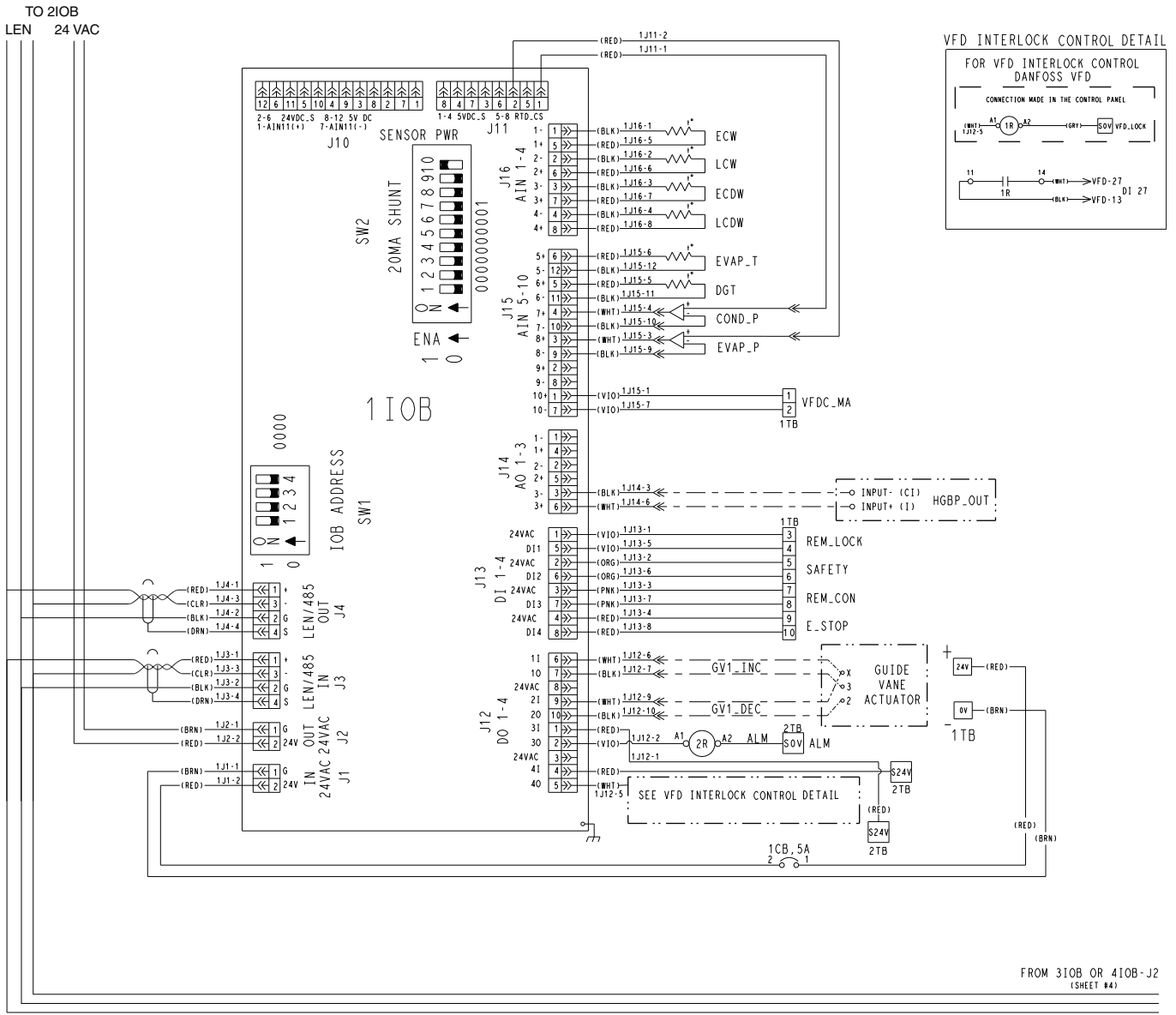

Fig. 63 — 19XR6-7 Control Panel, Bottom Layer

LEGEND FOR Fig. 64 19XR2-E Chiller Control Schematic

1FU	— Fuse, 5A		WIRING
2FU	— Fuse, 10A		Factory Wiring
1C	— Oil Heater Contactor		Mechanically Connected
2C	— Oil Pump Contactor		Power Panel Terminal Block
3C	— EC Valve Solenoid Open Relay		Conductor Male/Female Conductor
1-4IOB	— Carrier Input Output Board 1-4		Field Wiring
1-4TB	— Terminal Block 1-4		Optional Wiring
ALE	— Chiller Alert Relay		Component / Panel Enclosure
ALM	— Chiller Alarm Relay		Control Panel Terminal Block
AUTO_DEM	— Auto Demand Limit Input		Oil Pump Terminal
AUTO_RES	— Auto Water Temp Reset		Wire Splice
CB2/3	— Circuit Breaker 2/3		Component Terminal
CDW_DP	— Cond Water Pressure Difference		Motor Starter Panel Conn
CDWP	— Condenser Water Pump		Thermistor
CDWP_V	— Condenser Water Pump (Variable Speed)		Contactor / Relay Coil
CHRS	— Chiller Run Status		Contactor Contact (N.O.)
CHST_OUT	— Chiller Status Output mA		High Pressure Switch
CHW_DP	— Chilled Water Pressure Difference		Pressure Transducer
CHWP	— Chilled Water Pump		Oil Heater
CHWP_V	— Chilled Water Pump (Variable Speed)		Circuit Breaker
CHWR_T	— Common Chilled Water Return Temperature		
CHWS_T	— Common Chilled Water Supply Temperature		
COND_EWP	— Entering Cond Water Pressure		
COND_FL	— Cond Water Flow Measurement		
COND_FS	— Cond Water Flow Switch		
COND_LH	— Cond Sump Level High		
COND_LL	— Cond Sump Level Low		
COND_LWP	— Leaving Cond Water Pressure		
COND_P	— Condenser Pressure		
CUS_ALE	— Customer Alert		
CVSI	— Compressor VFD/Starter Interlock		
DGT	— Compressor Discharge Temperature		
DIFF_OUT	— Diffuser Output		
DIFF_P	— Diffuser Pressure		
DMP_CL	— Economizer Damper Valve Close		
DMP_FC	— Damper Valve Feedback Fully Close		
DMP_FO	— Damper Valve Feedback Fully Open		
DMP_OP	— Economizer Damper Valve Open		
E_STOP	— Remote Emergency Stop Input		
ECDW	— Entering Condenser Water Temperature		
ECON_P	— Economizer Pressure		
EC_VALVE	— Envelope Control Valve		
ECW	— Entering Chilled Water Temperature		
EVAP_FL	— Evap Water Flow Measurement		
EVAP_FS	— Evap Water Flow Switch		
EVAP_P	— Evaporator Pressure		
EVAP_T	— Evap Refrigerant Liquid Temperature		
FC_MODE	— Free Cooling Mode		
FC_SS	— Free Cooling Start Switch		
FS_LOCK	— Fire Security Interlock		
GV1_DEC	— Stage 1 IGV Decrease		
GV1_INC	— Stage 1 IGV Increase		
GV1_OUT	— Guide Vane 1 Output		
GV1_POS	— Guide Vane 1 Actual Position		
HDPV_OUT	— head pressure output		
HGBP_MA	— EC Valve Feedback		
HGBP_OP	— EC Valve Solenoid/Open		
HGBP_OUT	— EC Valve Output mA		
HMI	— Human Machine Interface (Touch Screen)		
HP_SW	— High Pressure Switch		
HR_EWT	— Heat Reclaim Entering Temperature		
HR_LWT	— Heat Reclaim Leaving Temperature		
ICE_CON	— Ice Build Contact		
IGV	— Integrated Guide Vane		
LCDW	— Leaving Condenser Water Temperature		
LCW	— Leaving Chilled Water Temperature		
LLC_EXV	— Liquid Level EXV Output		
LOWLIFT_OUT	— Low Lift Valve Output		
MTRB_OIL	— Thrust Bearing Oil Temperature		
MTRW1	— Motor Winding Temperature 1		
MTRW2	— Motor Winding Temperature 2		
MTRW3	— Motor Winding Temperature 3		
OIL_EXVO	— Oil EVX Output		
OIL_HEAT	— Oil Heater Relay		
OIL_PUMP	— Oil Pump Relay		
OILP_DIS	— Oil Supply Pressure		
OILP_SMP	— Oil Sump Pressure		
OILT_DIS	— Oil Supply Temperature		
OILT_SMP	— Oil Sump Temperature		
POW_FDB	— Power Request Feedback		
POW_REQ	— Power Request Output		
R_RESET	— Remote Reset Sensor		
REF_LEAK	— Refrigerant Leak Sensor		
REM_CON	— Remote Contact Input		
REM_LOCK	— Chiller Lockout Input		
SAFETY	— Spare Safety		
T1/2	— Transformer 1/2		
TFR_HIGH	— Tower Fan High		
TFR_LOW	— Tower Fan Low		
TOW_FAN	— Tower Fan (Variable Speed)		
VFDC_MA	— FS VFD Load Current		
VS_SV	— Vapor Source SV		
		BLK	Black
		BLU	Blue
		BRN	Brown
		GRN	Green
		GRY	Gray
		RED	Red
		WHT	White
		YEL	Yellow
		Y/G	Yellow/green
		ORG	Orange



FROM DRAWING 19XR05044701 REV H

Fig. 64 — 19XR2-E Chiller Control Schematic

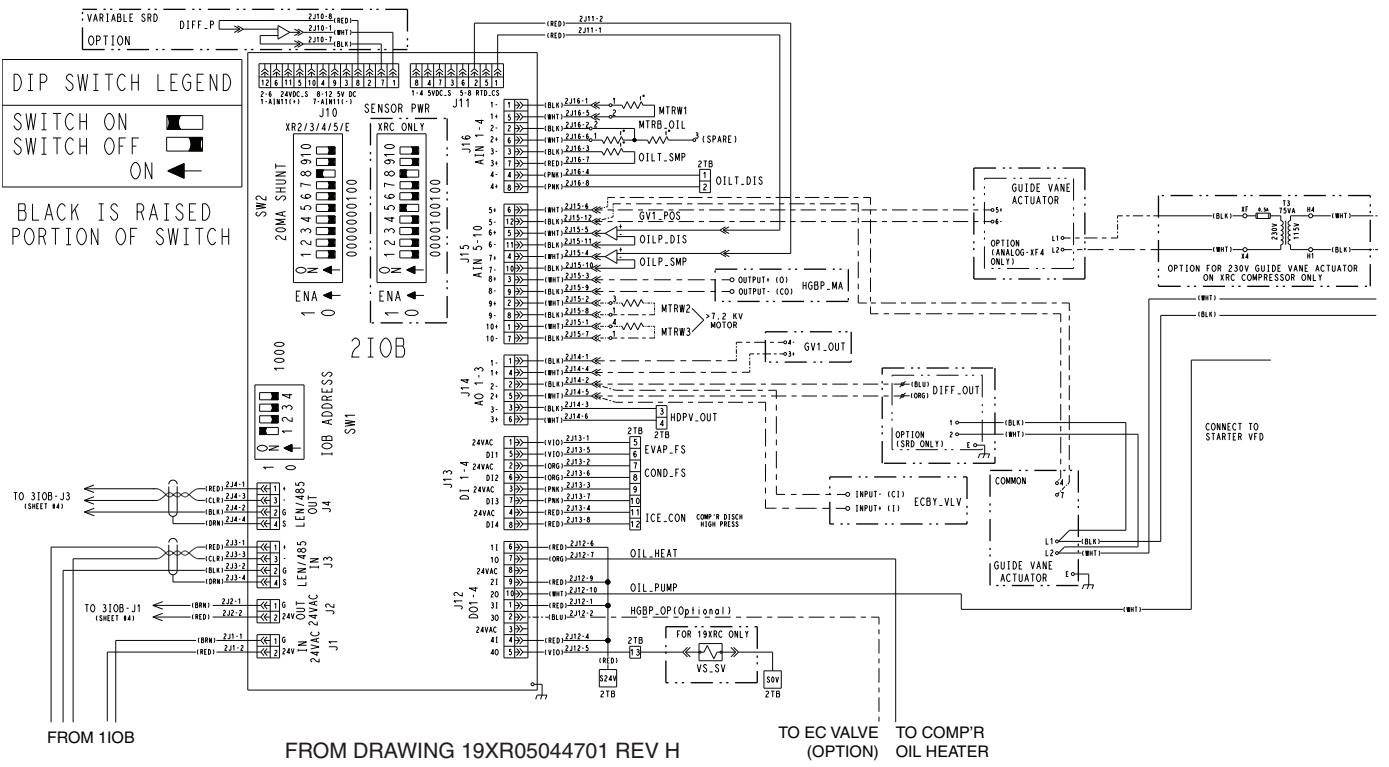
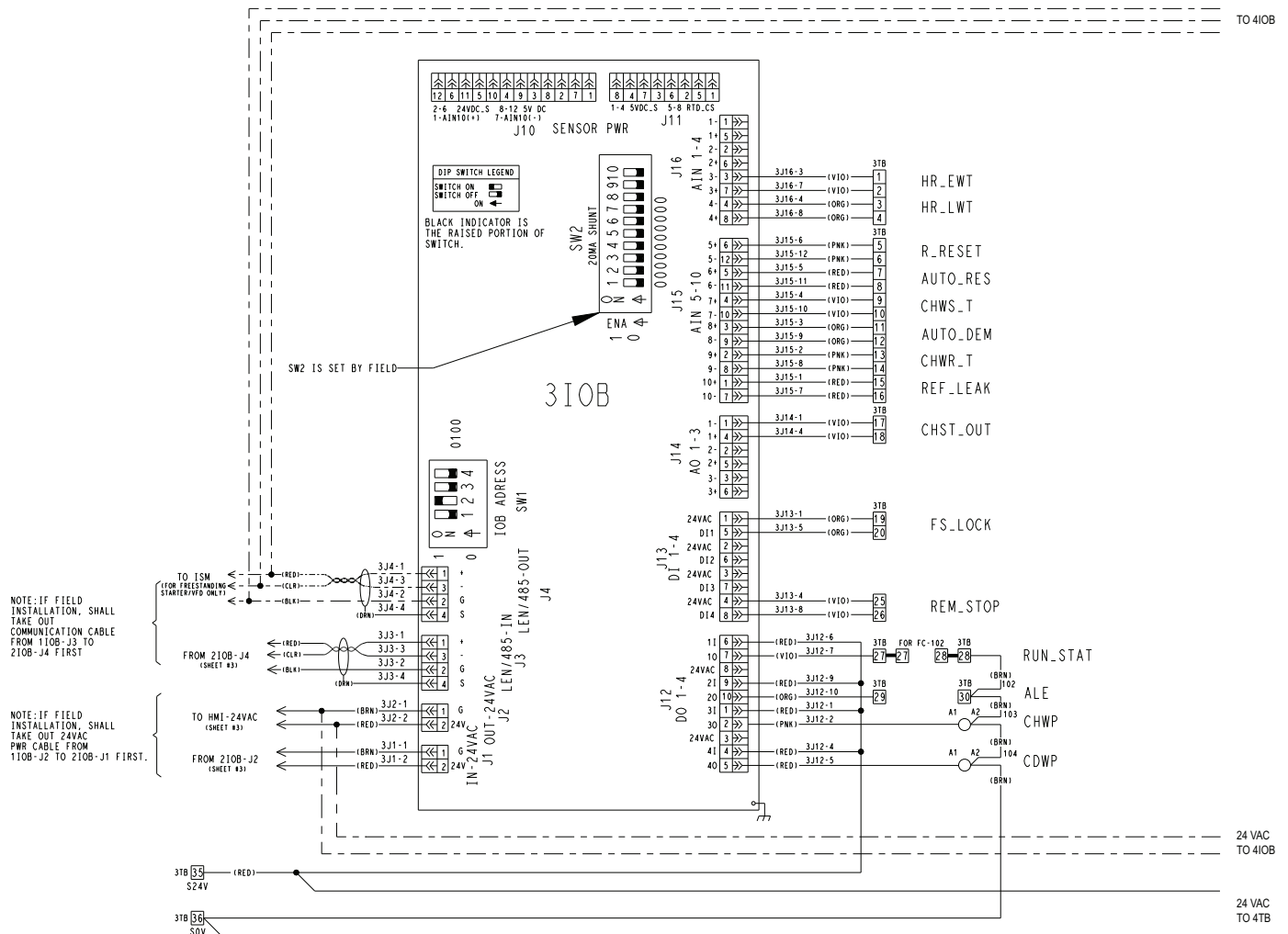

Fig. 64 — 19XR2-E Chiller Control Schematic (cont)



FROM DRAWING 19XR05044701 REV H

Fig. 64 — 19XR2-E Chiller Control Schematic (cont)

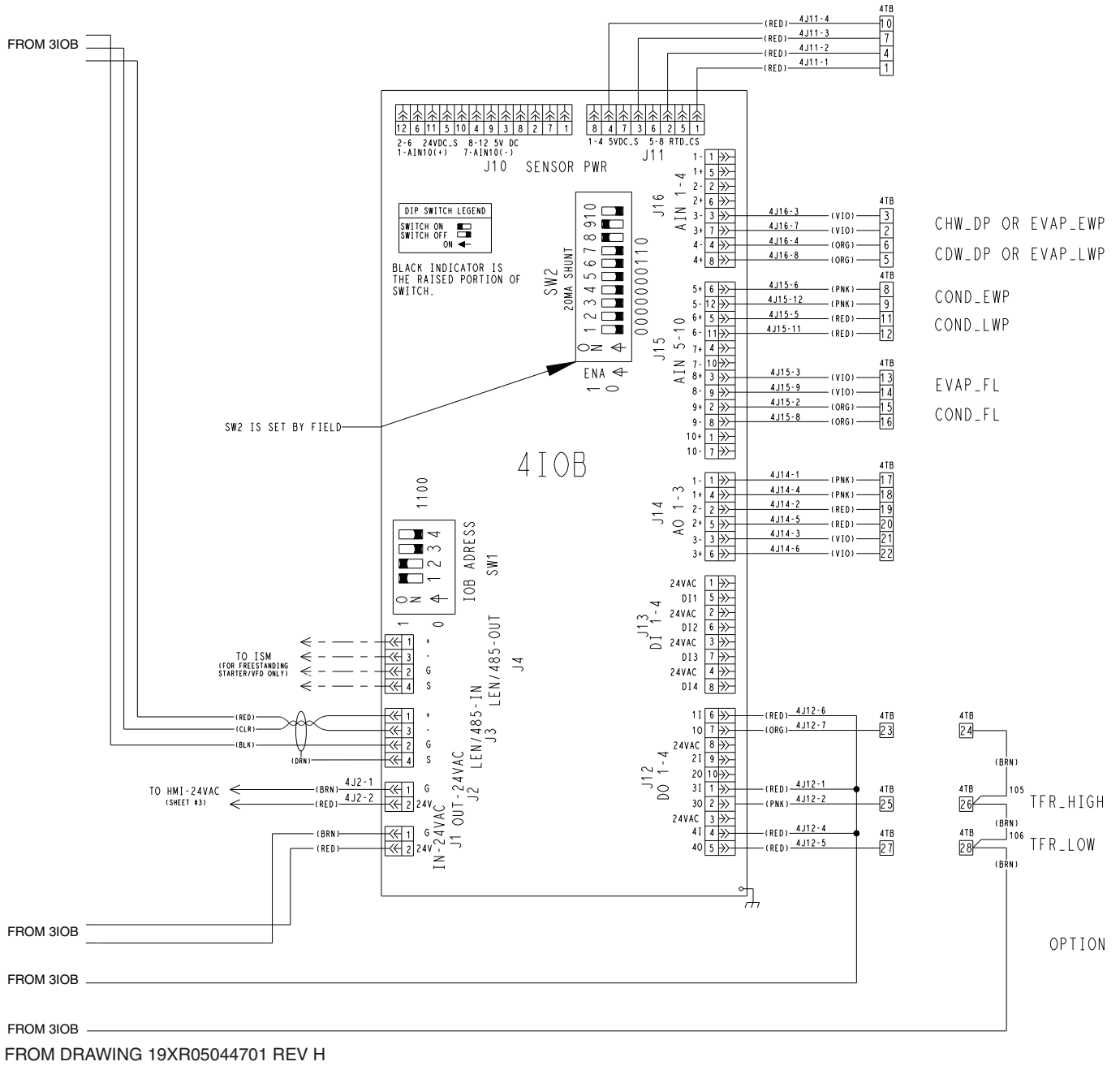
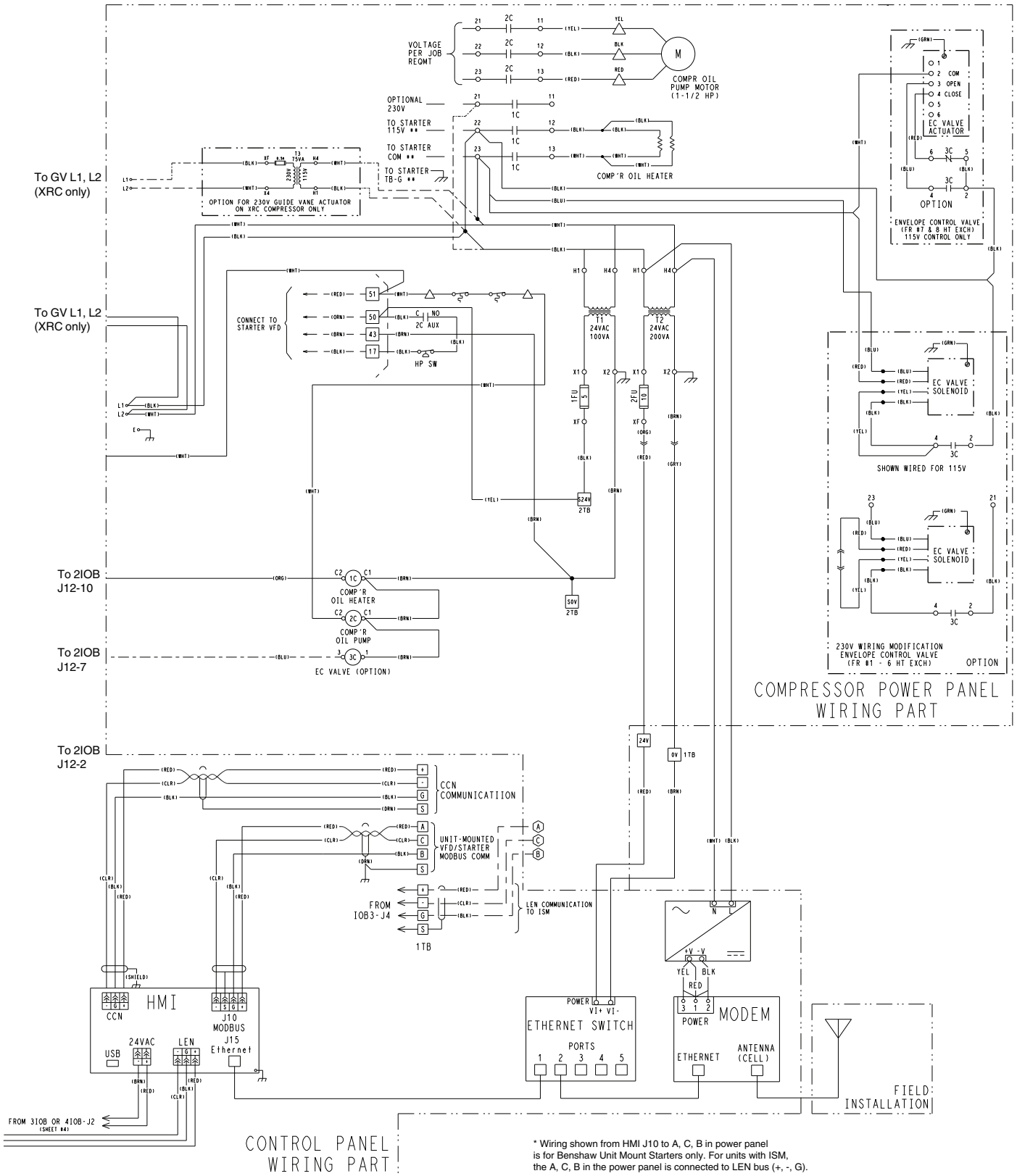
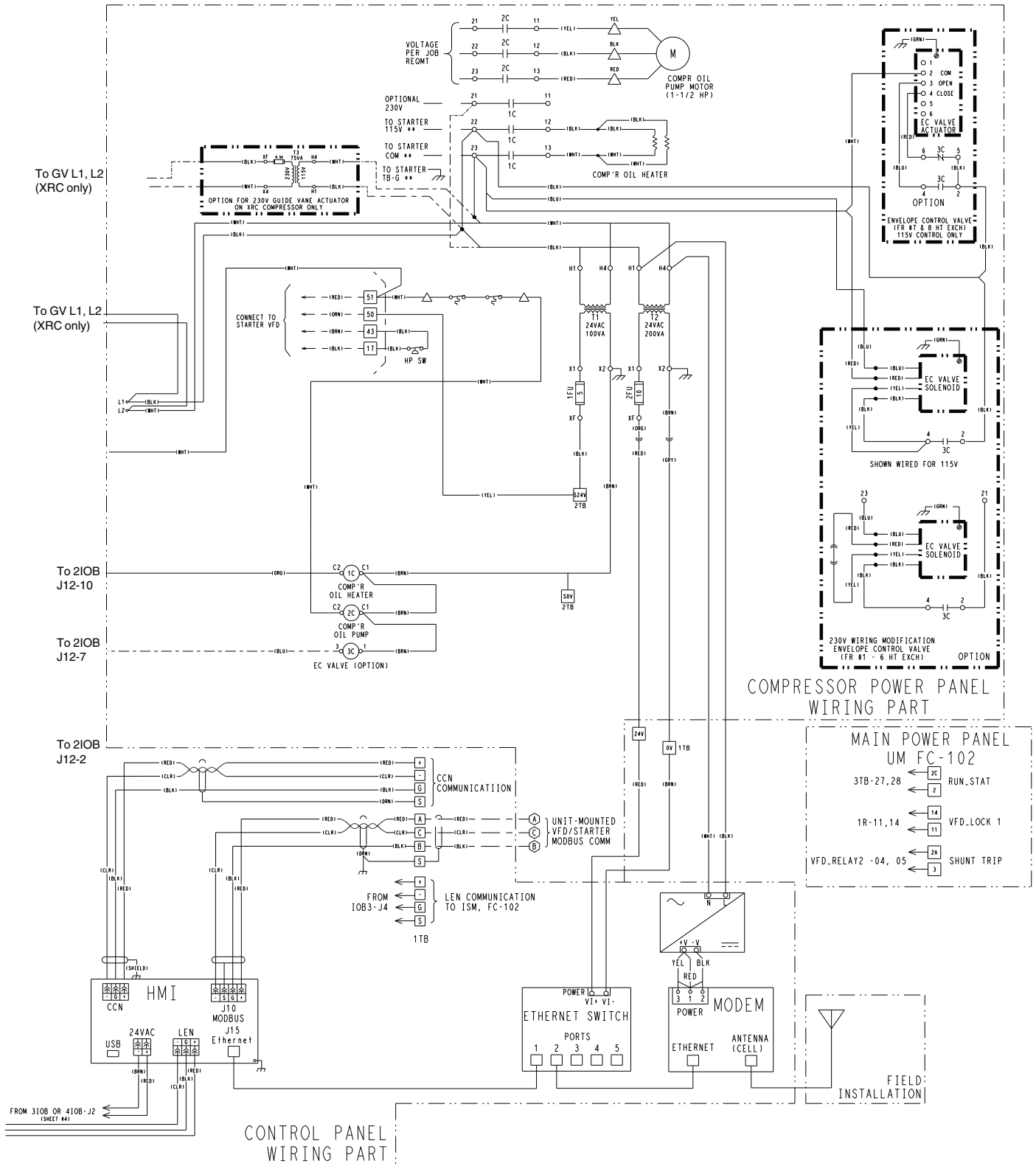

Fig. 64 — 19XR2-E Chiller Control Schematic (cont)



FROM DRAWING 19XR05044701 REV H

Fig. 65 — 19XR2-E Chiller Control Schematic for Non-Unit Mount VFD Chiller (Fixed Speed Chiller and Freestanding VFD)



FROM DRAWING 19XR05044701 REV H

Fig. 66 — 19XR2-E Chiller Control Schematic for Unit Mount VFD Chiller

LUG CAPACITY: 8AWG MAX

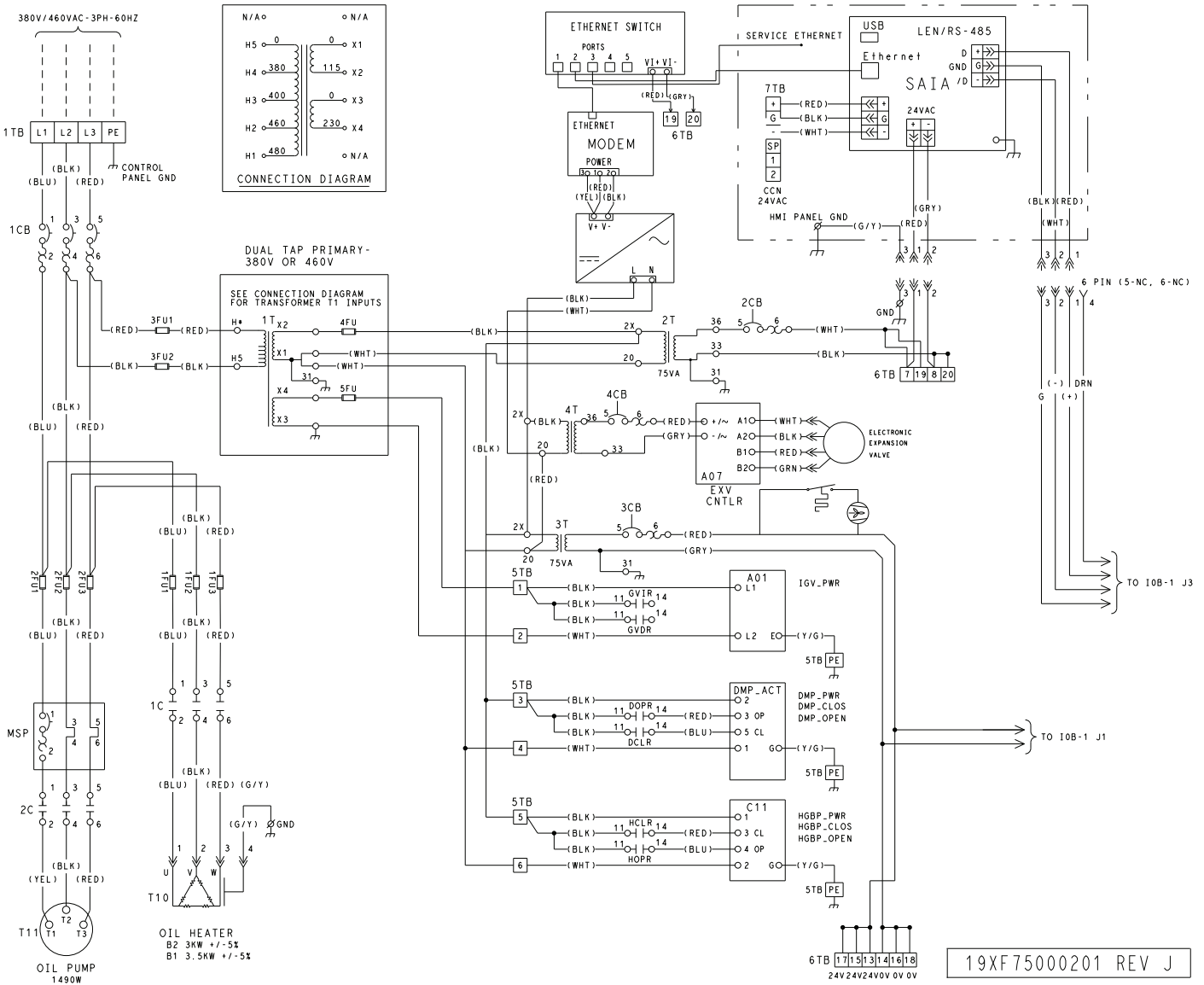

Fig. 67 — 19XR6-7 Controls Diagram

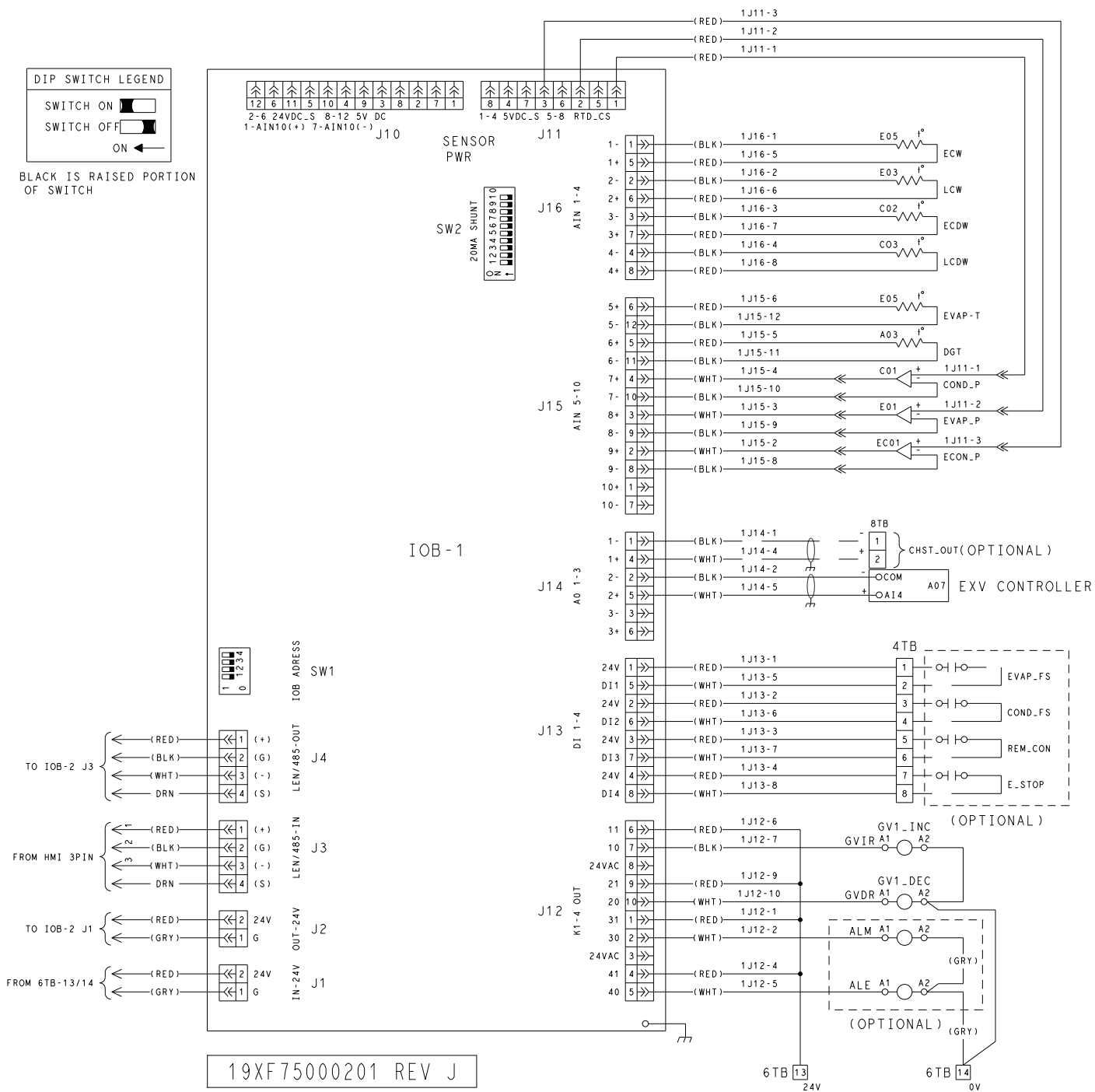

Fig. 68 — 19XR6-7 Chiller Control Schematic

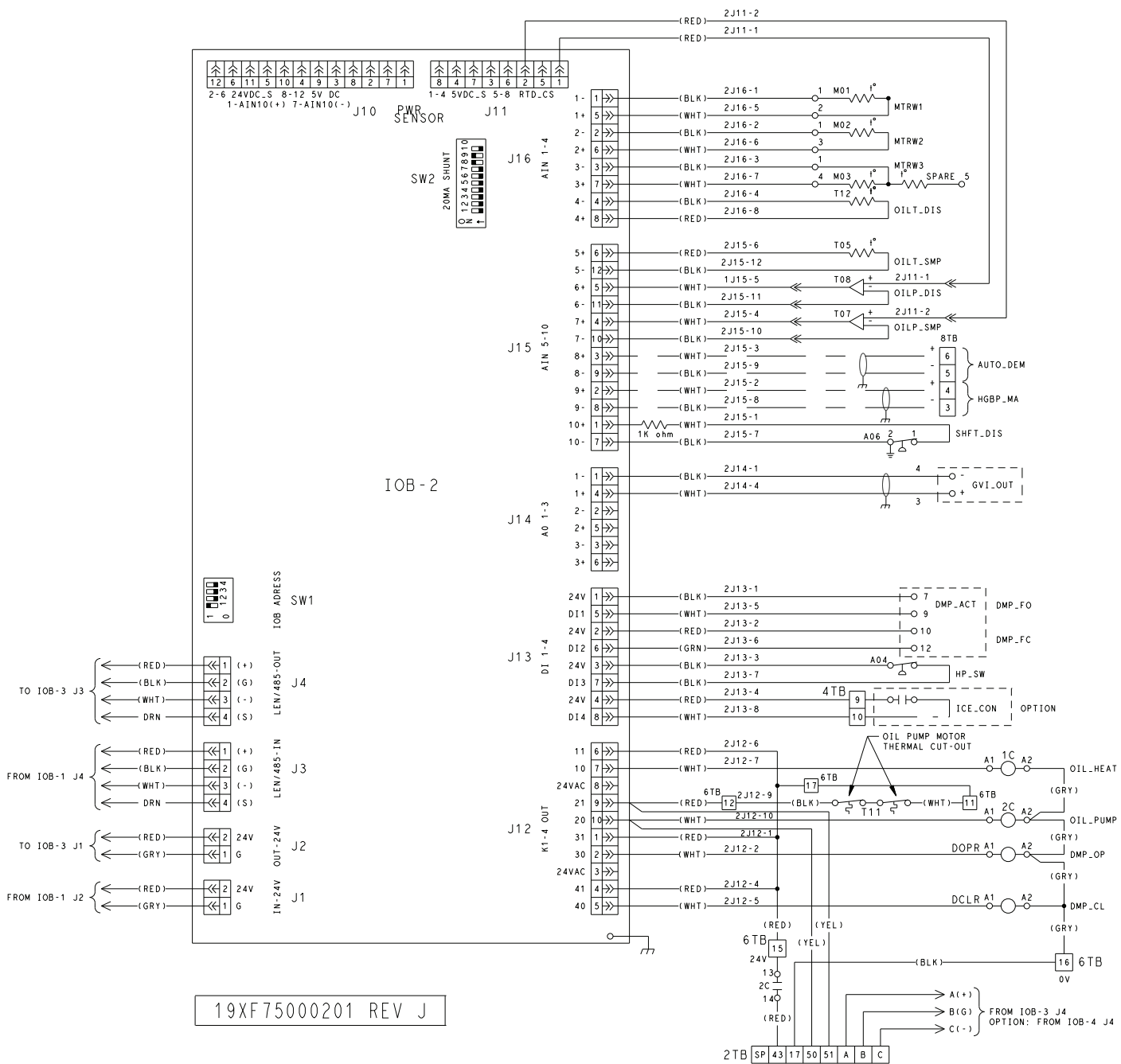

Fig. 68 — 19XR6-7 Chiller Control Schematic (cont)

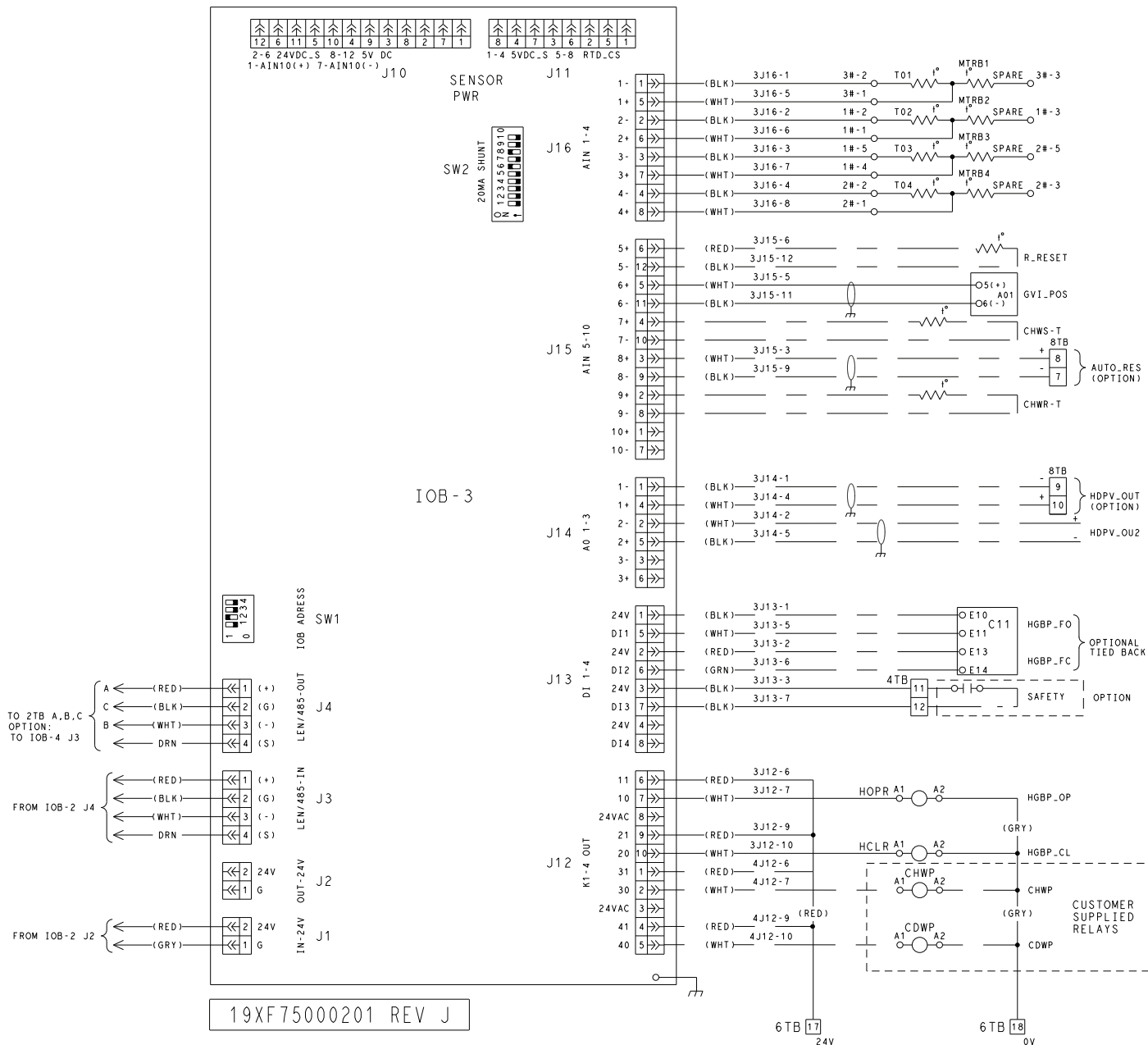

Fig. 68 — 19XR6-7 Chiller Control Schematic (cont)

NOTE:
 ALL CONNECTIONS ON THIS PAGE ARE OPTIONAL.
 3TB IS INCLUDED IN CONTROL BOX BUT NOT
 CONNECTED TO RELAY CONTACTS.
 CUSTOMER NEEDS TO SUPPLY ALL RELAYS ON THIS PAGE.
 RELAY SPEC:
 COIL: 24VAC/RLA: 1.8 AMPS.

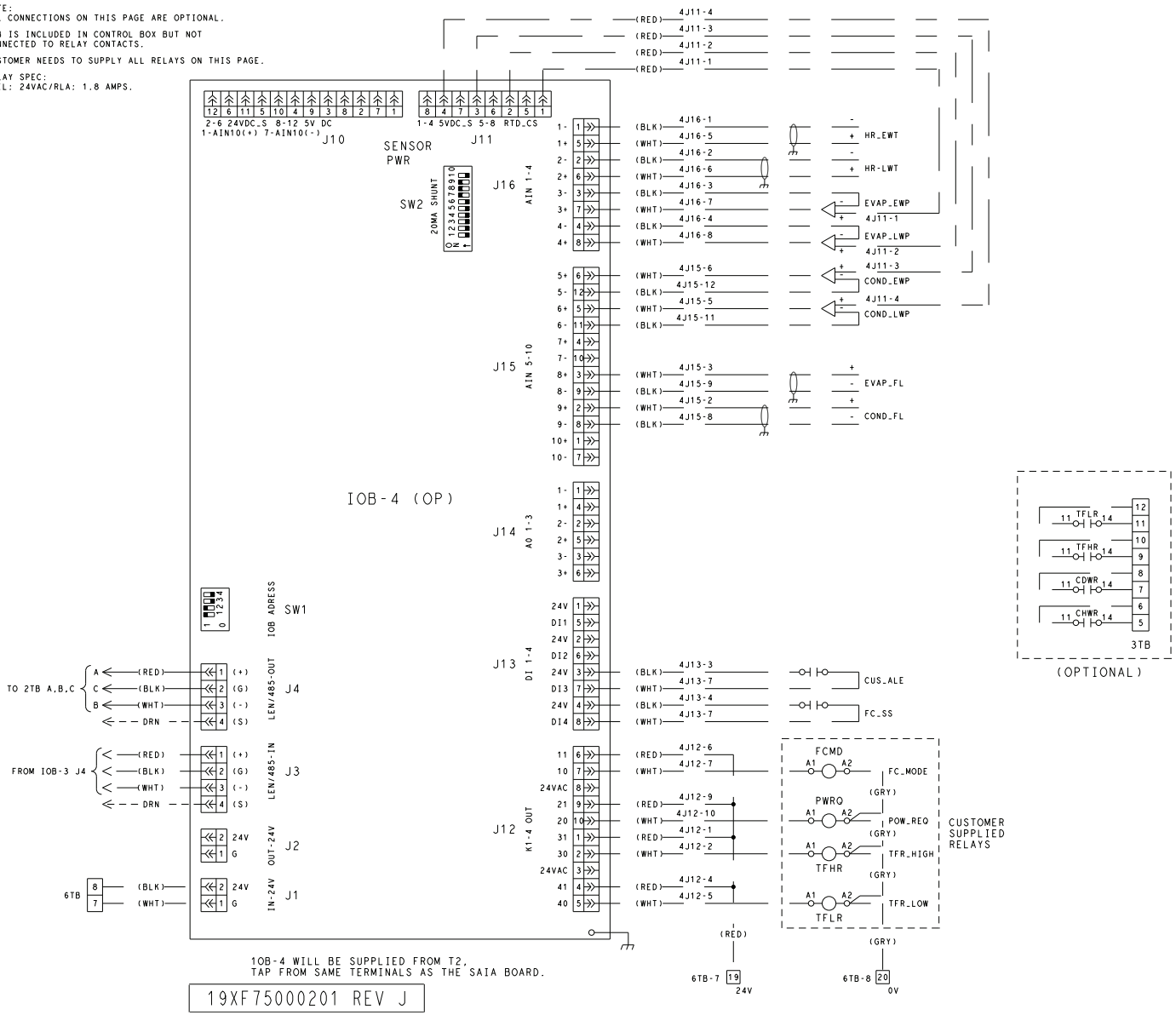

Fig. 68 — 19XR6-7 Chiller Control Schematic (cont)

FOR CUSTOMER SUPPLIED CONNECTION POINTS
USE MOLEX CONNECTOR AND FEMALE PIN SHOWN HERE.

CUSTOMER OPTIONAL PLUG CONNECTOR P/N		
ITEM	MOLEX P/N	CARRIER P/N
PIN REMOVAL TOOL	11-03-0044	--
FEMALE PIN	46018-1541	19XF05002401
J1 PLUG (2 PIN)	39-01-2025	19XF05002201
J3 PLUG (4 PIN)	39-01-2045	19XF05002202
J11 PLUG (8PIN-BLACK)	150-36-1713	19XF05002207
J12 PLUG (10 PIN)	39-01-2105	19XF05002205
J13 PLUG (8 PIN)	39-01-2085	19XF05002204
J14 PLUG (6 PIN)	39-01-2065	19XF05002203
J15 PLUG (12 PIN)	39-01-2125	19XF05002206
J16 PLUG (8 PIN)	39-01-2085	19XF05002204

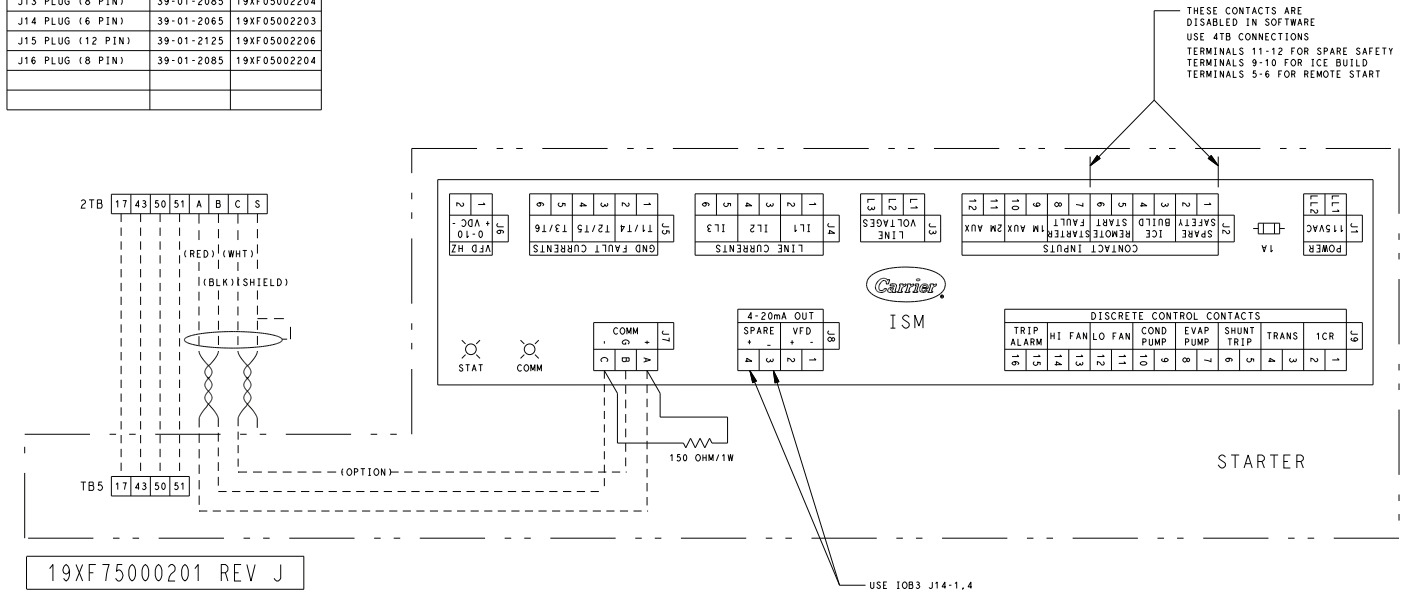

Fig. 69 — 19XR6-7 Starter Wiring

LEGEND FOR Fig. 67-69

Control Abbreviations — Fig. 67-69

ALE	— Chiller Alert
ALM	— Chiller Alarm
AUTO_DEM	— Demand Limit Input
AUTO_RES	— Auto Water Temp Reset
CHST_OUT	— Chiller Running (On/Off/Ready)
CHW_DP	— Chilled Water Pressure Difference
CHWP	— Chilled Water Pump
CHWP_V	— Chilled Water Pump (Variable)
CHWR	— Chilled Water Return
CHWS	— Chilled Water Supply
CDWP	— Condenser Water Pump
CDWP-V	— Condenser Water Pump (Variable)
CHWP	— Chilled Water Pump
CHWP_V	— Chilled Water Pump (Variable)
COND_EWP	— Entering Condenser Water Pressure
COND_FL	— Condenser Water Flow Measurement
COND_FS	— Condenser Water Flow Switch
COND_LWP	— Leaving Condenser Water Pressure
COND_P	— Condenser Pressure
CUS_ALE	— Customer Alert
DGT	— Compressor Discharge Temperature
DMP_CL	— Economizer Damper Valve Close
DMP_FC	— Damper Valve Feedback Fully Close
DMP_FO	— Damper Valve Feedback Fully Open
DMP_OP	— Economizer Damper Valve Open
ECDW	— Entering Condenser Water Temperature
ECON_P	— Economizer Pressure
ECW	— Entering Chilled Water Temperature
ERT	— Evaporator Refrigerant Temperature
EVAP_EWP	— Entering Evaporator Water Pressure
EVAP_FL	— Evaporator Water Flow Measurement
EVAP_LWP	— Leaving Evaporator Water Pressure
EVAP_P	— Evaporator Pressure
FS-SS	— Free Cooling Start Switch
GV1-ACT	— IG1 Position Input
GV1_OUT	— IG1 Control Signal
HDPV_OUT	— Head Pressure Output
HGBP_CL	— Hot Gas Bypass (HGBP) Valve Close
HGBP_FC	— Hot Gas Bypass Valve Feedback Fully Close
HGBP_FO	— Hot Gas Bypass Valve Feedback Fully Open
HGBP_OP	— Hot Gas Bypass Valve Open
HP_SW	— High Pressure Switch
ICE_CON	— Ice Build Contact
LCDW	— Leaving Condenser Water Temperature
LCW	— Leaving Chilled Water Temperature
MTRB1	— Low Speed Motor End Bearing Temperature (Thermistor/PT100)
MTRB2	— Low Speed Compressor End Bearing Temperature (Thermistor/PT100)
MTRB3	— High Speed Motor End Bearing Temperature (Thermistor/PT100)
MTRB4	— High Speed Compressor End Bearing Temperature (Thermistor/PT100)
MTRW1	— Motor Winding Temperature 1
MTRW2	— Motor Winding Temperature 2
MTRW3	— Motor Winding Temperature 3
OIL_HEAT	— Oil Heater On/Off
OIL_PUMP	— Oil Pump On/Off
OILP_DIS	— Oil Pump Discharge Pressure
OILP_SMP	— Oil Sump Pressure
OILT_SMP	— Oil Sump Temperature
REM_CON	— Remote Connect Input
REM_LOCK	— Chiller Lockout Input
REM_STP	— Remote Stop Lock
SAFETY	— Spare Safety
SHFT_DIS	— Bearing Shaft Displacement Switch
TFR_HIGH	— Tower Fan High
TFR_LOW	— Tower Fan Low

Wiring Codes — Fig. 67-69

1C	— Oil Heater Contactor
2C	— Oil Pump Contactor
1CB	— Micro Circuit Breaker, Control Box
2CB	— Micro Circuit Breaker, HMI
3FU1,2	— Transformer 1 Primary Fuse
3FU3,4	— Transformer 1 Secondary Fuse
1R	— Alarm Relay
1T	— Transformer 1
2T	— Transformer 2
3T	— Transformer 3
1TB	— Terminal Block for Customer Power Connection
2TB	— Terminal Block for Field Connection
3TB	— Terminal Block for Customer Optional Connection
4TB	— HMI Terminal Block Field CCN Connection
5TB	— Terminal Block for Control Panel Internal Connection
6TB	— Terminal Block for Guide Vane, HGBP and Damper Valve
7TB	— Terminal Block for Guide Vane Actuator (220 v)
A01	— IG1/Stage 1 IG1
A03	— Discharge Gas Temperature Thermistor
A04	— High Pressure Switch
A06	— Bearing Displacement Switch
C11	— HGBP Valve Actuator
E01	— Evaporator Pressure Transducer
E03	— Leaving Chilled Water Temperature Thermistor
E05	— Evaporator Refrigerant Liquid Temperature Thermistor
EC01	— Economizer Pressure Transducer
EC06	— Damper Valve Actuator
HMI	— Human Interface Panel
ISM	— Integrated Starter Module
M01	— Motor Winding Temperature 1 (Thermistor/PT100)
M02	— Motor Winding Temperature 2 (Thermistor/PT100)
M03	— Motor Winding Temperature 3 (Thermistor/PT100)
MSP	— Motor Starter Protection
SAIA	— SAIA Touch Screen and Main Board
T01	— Low Speed Motor End Bearing Temperature (Thermistor/PT100)
T02	— Low Speed Compressor End Bearing Temperature (Thermistor/PT100)
T03	— High Speed Motor End Bearing Temperature (Thermistor/PT100)
T04	— High Speed Compressor End Bearing Temperature (Thermistor/PT100)
T05	— Oil Sump Temperature Thermistor
T07	— Oil Sump Pressure Transducer
T08	— Oil Pump Discharge Pressure Transducer
T10	— Oil Heater
T11	— Oil Pump

Symbols — Fig. 67-69

○	Component Terminal
→↔	Conductor Male/Female Connector
— —	Field Wiring
- - - -	Optional Wiring
— ·	Component/Panel Enclosure
□	Terminal Block for Field Wiring
∅	Terminal Block for Internal Connection
•	Wire Splice

APPENDIX A — PIC 6 SCREEN AND TABLE STRUCTURE

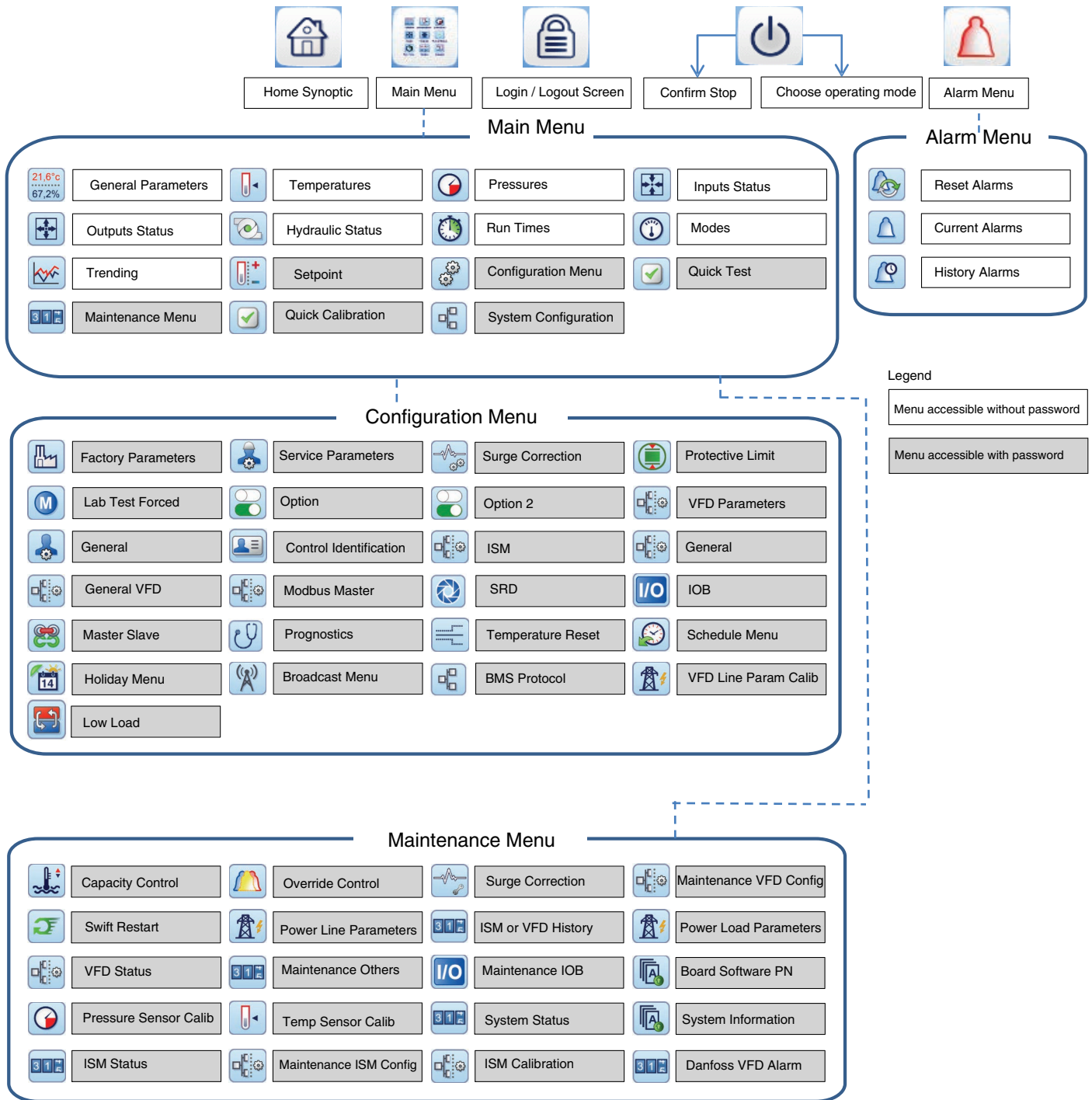















19XR Menu — Note that the available menu options shown in Menu are dependent upon unit selections.

Fig. A — Screen Structure

APPENDIX A — PIC 6 SCREEN AND TABLE STRUCTURE (cont)

Main Menu Description

ICON	DISPLAYED TEXT*	ACCESS	ASSOCIATED TABLE
	General Parameters	All	GENUNIT
	Temperatures	All	TEMP
	Pressures	All	PRESSURE
	Inputs Status	All	INPUTS
	Outputs Status	All	OUTPUTS
	Hydraulic Status	All	HYDRLIC
	Run Times	All	RUNTIME
	Modes	All	MODES
	Trending	All	TRENDING
	Setpoint	User	SETPOINT
	Configuration Menu	User	CONFIG
	Quick Test	Service	QCK_TEST
	Maintenance Menu	Service	MAINTAIN
	Quick Calibration	Service	QCK_CAL
	System Configuration	User	System Configuration

* Displayed text depends on the selected language (default is English).
 NOTE: In most cases User login does not gain access to all configurations screens in a given menu.

APPENDIX B — CCN COMMUNICATION WIRING FOR MULTIPLE CHILLERS (TYPICAL)

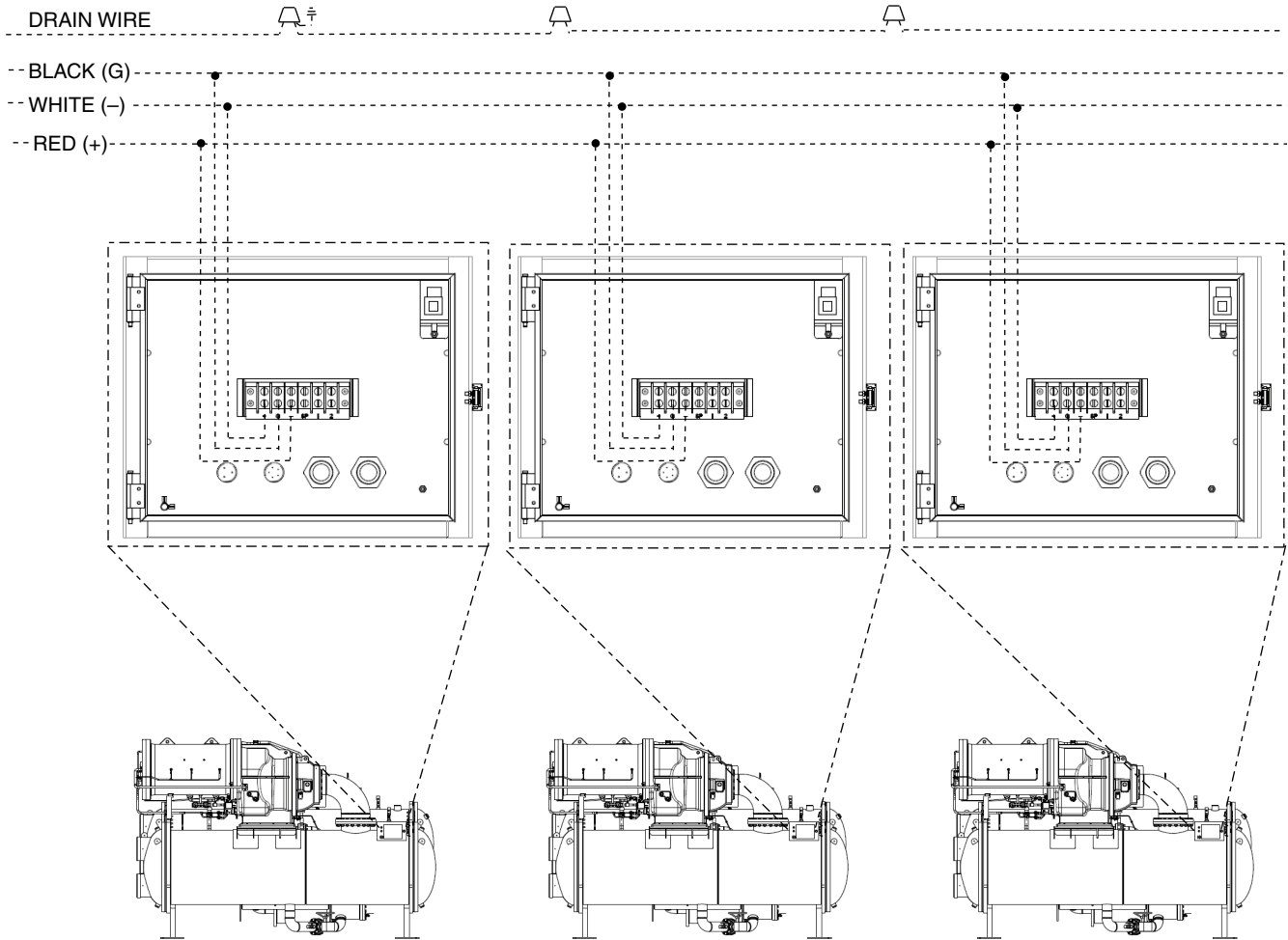

NOTE: Field-supplied terminal strip must be located in control panel.

19XR6-7 shown (HMI control box) - for 19XR2-E the CCN connection is located in the control panel (see below — 19XR2-E; CCN connection terminal block).

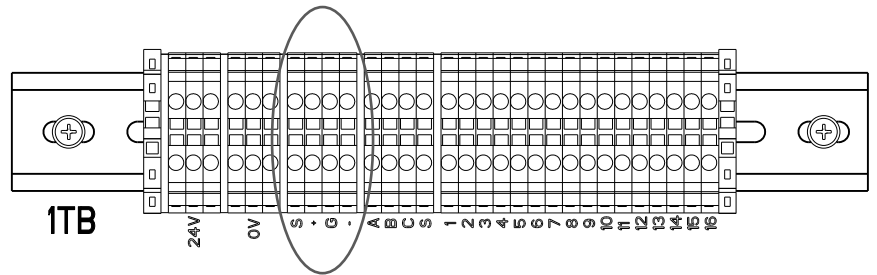
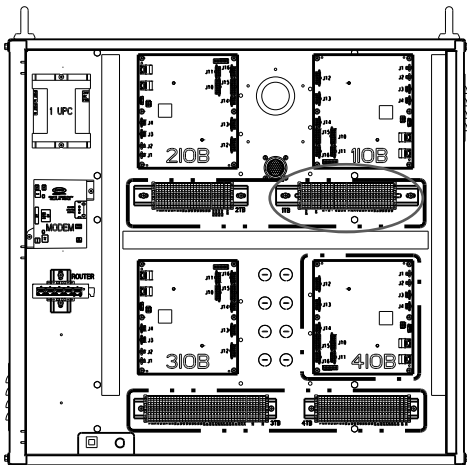

19XR2-E; CCN connection terminal block

APPENDIX C — MAINTENANCE SUMMARY AND LOG SHEETS

19XR Maintenance Interval Requirements

WEEKLY			
COMPRESSOR	Check Oil Level.	CONTROLS	Review PIC 6 Alarm/Alert History.
COOLER	None.	STARTER	None.
CONDENSER	None.	OIL RECLAIM	None.
MONTHLY			
COMPRESSOR	None.	CONTROLS	Perform an Automated Controls test.
COOLER	None.	STARTER	None.
CONDENSER	None.	OIL RECLAIM	None.
FIRST YEAR			
COMPRESSOR	Change oil filter. Send oil sample out for analysis. Change oil if required by analysis. Leak test.	CONTROLS	Perform general cleaning. Tighten connections. Check pressure transducers. Confirm accuracy of thermistors.
COOLER	Inspect and clean cooler tubes. Inspect relief valves. Leak test. Verify water pressure differential. Inspect water pumps and cooling tower.	STARTER	Perform general cleaning. Tighten connections. Change VFD refrigerant strainer.
CONDENSER	Replace refrigerant filter/drier. Inspect and clean condenser tubes. Inspect relief valves. Leak test. Verify water pressure differential. Inspect water pumps and cooling tower.	OIL RECLAIM	Inspect oil sump strainer.
ANNUALLY			
COMPRESSOR	Change oil filter. Send oil sample out for analysis. Change oil if required by analysis. Leak test.	CONTROLS	Perform general cleaning. Tighten connections. Check pressure transducers. Confirm accuracy of thermistors.
COOLER	Inspect and clean cooler tubes. Inspect relief valves. Leak test. Verify water pressure differential. Inspect water pumps and cooling tower.	STARTER	Perform general cleaning. Tighten connections.
CONDENSER	Replace refrigerant filter/drier. Inspect and clean condenser tubes. Inspect relief valves. Leak test. Verify water pressure differential. Inspect water pumps and cooling tower.	OIL RECLAIM	None.
STARTING EQUIPMENT	Follow all lockout-tagout procedures. Inspect inside of enclosure for contaminant build-up. Vacuum any accumulated dust or debris from internal parts. Use electronic cleaner as required.		
EVERY 3-5 YEARS			
COMPRESSOR	None.	CONTROLS	None.
COOLER	Perform eddy current test.	STARTER	None.
CONDENSER	Inspect float valve and strainer. Perform eddy current test.	OIL RECLAIM	None.
EVERY 5 YEARS			
COMPRESSOR	Change oil charge (if required based on oil analysis or if oil analysis has not been performed).	CONTROLS	None.
COOLER	None.	STARTER	None.
CONDENSER	None.	OIL RECLAIM	Inspect oil sump strainer. Inspect oil sump heater. Replace the oil reclaim filter.
SEASONAL SHUTDOWN			
COMPRESSOR	None.	CONTROLS	Do not disconnect control power.
COOLER	Isolate and drain waterbox. Remove waterbox cover from one end. Use compressed air to clear tubes.	STARTER	None.
CONDENSER	Isolate and drain waterbox. Remove waterbox cover from one end. Use compressed air to clear tubes.	OIL RECLAIM	None.

NOTE: Equipment failures caused by lack of adherence to the Maintenance Interval Requirements may lose warranty coverage. See warranty terms and conditions.

APPENDIX C — MAINTENANCE SUMMARY AND LOG SHEETS (cont)

19XR Monthly Maintenance Log

MONTH			1	2	3	4	5	6	7	8	9	10	11	12
DATE			/ /	/ /	/ /	/ /	/ /	/ /	/ /	/ /	/ /	/ /	/ /	/ /
OPERATOR														
UNIT SECTION	ACTION	UNIT	ENTRY											
COMPRESSOR	Change Oil Charge	yes/no												
	Change Oil Filter	yes/no												
	Send Oil Sample Out for Analysis	yes/no												
	Leak Test	ppm												
	Inspect Compressor Rotors	yes/no												
	Bearing Inspection	yes/no												
COOLER	Inspect and Clean Cooler Tubes	yes/no												
	Inspect Relief Valves	yes/no												
	Leak Test	ppm												
	Record Water Pressure Differential (PSI)	PSI												
	Inspect Water Pumps	yes/no												
	Eddy Current Test	yes/no												
CONDENSER	Leak Test	ppm												
	Inspect and Clean Condenser Tubes	yes/no												
	Record Water Pressure Differential (PSI)	PSI												
	Inspect Water Pumps and Cooling Tower	yes/no												
	Inspect Relief Valves	yes/no												
	Replace Refrigerant Filter Drier	yes/no												
	Inspect Float Valve and Strainer	yes/no												
	Eddy Current Test	yes/no												
CONTROLS	General Cleaning and Tightening Connections	yes/no												
	Check Pressure Transducers	yes/no												
	Confirm Accuracy of Thermistors	yes/no												
	Perform Automated Controls Test	yes/no												
STARTER	General Tightening and Cleaning Connections	yes/no												
OIL RECLAIM	Inspect Oil Sump Strainer	yes/no												
	Inspect Oil Sump Heater	yes/no												

NOTE: Equipment failures caused by lack of adherence to the Maintenance Interval Requirements are not covered under warranty.

APPENDIX C — MAINTENANCE SUMMARY AND LOG SHEETS (cont)

19XR Seasonal Shutdown Log

MONTH		1	2	3	4	5	6	7	8	9	10	11	12
DATE		/ /	/ /	/ /	/ /	/ /	/ /	/ /	/ /	/ /	/ /	/ /	/ /
OPERATOR													

UNIT SECTION	ACTION	ENTRY											
COOLER	Isolate and Drain Waterbox												
	Remove Waterbox Cover from One End												
	Use Compressed Air to Clean Tubes												
CONDENSER	Isolate and Drain Waterbox												
	Remove Waterbox Cover from One End												
	Use Compressed Air to Clean Tubes												
CONTROLS	Do Not Disconnect Control Power												

NOTE: Equipment failures caused by lack of adherence to the Maintenance Interval Requirements are not covered under warranty.

INDEX

- Abbreviations and explanations, 4
- Bearing and gear maintenance, 49
- Bearings, 13
- Bolt torque requirements, 21
- Chiller
 - Components, 8-10
 - Dehydration, 25
 - Familiarization, 4
 - Information nameplate, 4
 - Leak test, 23
 - Limited shutdown, operation after, 38
 - Operating condition, checking, 37
 - Preparing for start-up, 38
 - Replacement parts, ordering, 50
 - Starting, 38
 - Stopping, 38
 - Tightness, checking, 21
- Cold weather operation, 39
- Compressor
 - Assembly torques, 90, 91
 - Bearing and gear maintenance, 49
 - Description, 4
 - Fits and clearances, 82-89
- Condenser
 - Description, 4
- Control Panel
 - Description, 4
 - Inspecting, 47
- Controller identification, modifying, 29
- Controls
 - Description, 17
 - PIC 6 system components, 17
 - Powering up, 28
- Cooler
 - Description, 4
- Display messages, checking, 51
- Economizer
 - Damper valve, 48
 - Description, 5
 - Float system, 48
- Equipment required, 20
- Extended shutdown
 - Preparing for, 38
 - Operation after, 39
- Field set up and verification, 31
- Gasketed joints, tightening, 21
- Guide vanes
 - Checking, 44
 - Operation, manual, 39
- Heat exchanger tubes and flow devices, maintenance, 49
- High altitude locations, 55
- Initial start-up, 37
- Initial start-up checklist, *CL-1*
- Inspecting equipment, 50
- Instructing customer operator, 37
- Job data required, 20
- Job site parameters, 31
- Leak test procedures (chart), 22
- Limited shutdown, operation after, 38
- Local start/stop control, 19
- Login/logout, 29
- Lubrication control, 20
- Lubrication cycle, 13
- Lubrication system, checking, 47
- Maintenance
 - General, 44
 - Scheduled, 47
 - Summary and log sheets, 112
 - Weekly, 47
- Motor and oil cooling cycle, 12
- Motor rotation, checking, 37
- Oil changes, 47
- Oil charge, 28
- Oil circuit valves, opening, 20
- Oil filter, changing, 47
- Oil heater, checking, 28
- Oil pressure and compressor stop, checking, 37
- Oil pump, 15
- Oil reclaim filter, 48
- Oil reclaim system, 13
- Oil recovery, 13
- Oil specification, 47
- Operating instructions, 38
- Operator duties, 38
- Passwords, 29
- Physical data, 55
- Piping
 - Inspecting before start-up, 25
 - Maintenance, 49
- Pressure transducers
 - Calibration, 55
 - Checking, 55
 - Recalibrating, 50
- Pumpdown/lockout, 55
- Pumpout and refrigerant transfer, 39
- Pumpout unit
 - Maintenance, 50
 - Operating, 41
- Quick test
 - Perform, 34
 - Use in troubleshooting, 55
- Refrigerant
 - Adding, 44
 - Adjusting charge, 44
 - Charging into chiller, 35
 - Filter, 47
 - Float system, inspecting, 48
 - Leak rate, 44
 - Leak testing, 44
 - Properties, 44
 - Testing after service, repair, or major leak, 44
 - Tracer, 23
 - Trimming charge, 44
- Refrigeration cycle, 11
- Refrigeration log, 39
- Relief valves
 - Checking before start-up, 25
 - Maintenance, 49
- Replacement parts, ordering, 50
- Running system, checking, 38
- Safety considerations, 2
- Schedule, inputting local occupied, 28
- Sensor accuracy, checking, 54
- Service configurations, inputting, 29
- Service ontime, 47
- Set points, inputting design, 28
- Shipping packaging, removing, 20
- Shutdown
 - After extended, 39
 - After limited, 38
 - Local (with HMI), 20
 - Preparation for extended, 38
- Software configuration, 28
- Standing vacuum test, 23
- Starter
 - Free-standing, description, 5
 - Mechanical, checking, 27
- Starting equipment, 16, 50
- Start-Up
 - Accidental, preventing, 37
 - Before initial, 20
 - Chiller dehydration, 25
 - Controls, powering up, 28
 - Control test (quick test), 34
 - Equipment required, 20
 - Field set up and verification, 31
 - Gasketed joints, tightening, 21
 - Initial, 37
 - Inspecting water piping, 25
 - Job data required, 20
 - Leak test, 23
 - Oil charge, 28
 - Oil circuit valves, opening, 20
 - Oil heater, checking, 28
 - Refrigerant, charging into chiller, 34
 - Relief valves, checking, 25
 - Schedule, inputting local occupied, 28
 - Service configurations, inputting, 29
 - Set points, inputting design, 28
 - Shipping packaging, removing, 20
 - Software configuration, 28
 - Standing vacuum test, 23
 - Starter, checking, 27
 - Tracer, 23
 - Wiring, inspecting, 26
- Start-up/shutdown/recycle sequence, 19
- Surge prevention, 31
- System components, 4
- Temperature sensors, checking, 18
- Thermistor temperature vs. resistance/ voltage drop (C) 53
- Thermistor temperature vs. resistance/ voltage drop (F) 52
- Time and date, inputting, 29
- Troubleshooting guide, 51
- Water
 - Leaks, 49
 - Treatment, 49
- Weights
 - Component, 81
 - Compressor and motor, 63-74
 - Economizer, 61
 - Heat exchanger, 57-61
 - Marine waterboxes, 61-62
 - Waterbox cover, 75-80
- Wiring
 - CCN for multiple chillers, 111
 - Control panel IOB layer, 92, 94
 - HMI panel, 93
 - IOB 1, 103
 - IOB 2, 104
 - IOB 3, 105
 - IOB 4, 106
 - Inspecting, 26
 - Pumpout unit schematic, 41
 - SAIA control board, 102
 - Starter, 107

**INITIAL START-UP CHECKLIST
FOR 19XR SEMI-HERMETIC CENTRIFUGAL LIQUID CHILLER
(Remove and use for job file.)**

NOTE: To avoid injury to personnel and damage to equipment or property when completing the procedures listed in this start-up checklist, use good judgment, follow safe practices, and adhere to the safety considerations/information as outlined in preceding sections of this Start-Up, Operation, and Maintenance Instructions document.

MACHINE INFORMATION:

NAME _____ JOB NO. _____
 ADDRESS _____ MODEL _____
 CITY _____ STATE _____ ZIP _____ S/N _____

DESIGN CONDITIONS:

	TONS	BRINE	FLOW RATE	TEMPERATURE IN	TEMPERATURE OUT	PRESSURE DROP	PASS	SUCTION TEMPERATURE	CONDENSER TEMPERATURE
COOLER									*****
CONDENSER								*****	

COMPRESSOR: Volts _____ RLA _____ OLTA _____
 STARTER: Mfg _____ Type _____ S/N _____
 OIL PUMP: Volts _____ RLA _____ OLTA _____

CONTROL PANEL SUPPLY: Voltage _____ Hertz _____

REFRIGERANT: Type: _____ Charge _____

CARRIER OBLIGATIONS: Assemble..... Yes No
 Leak Test Yes No
 Dehydrate Yes No
 Charging Yes No
 Operating Instructions _____ Hrs.

START-UP TO BE PERFORMED IN ACCORDANCE WITH APPROPRIATE MACHINE START-UP INSTRUCTIONS

JOB DATA REQUIRED:

1. Machine Installation Instructions Yes No
2. Machine Assembly, Wiring and Piping Diagrams Yes No
3. Starting Equipment Details and Wiring Diagrams Yes No
4. Applicable Design Data (see above) Yes No
5. Diagrams and Instructions for Special Controls Yes No

INITIAL MACHINE PRESSURE: _____

	YES	NO
Was Machine Tight?		
If Not, Were Leaks Corrected?		
Was Machine Dehydrated After Repairs?		

CHECK OIL LEVEL AND RECORD:

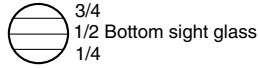
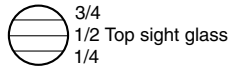

ADD OIL: Yes No

Amount: _____

RECORD PRESSURE DROPS: Cooler _____

Condenser _____

CHARGE REFRIGERANT: Initial Charge _____

Final Charge After Trim _____

INSPECT WIRING AND RECORD ELECTRICAL DATA:

RATINGS:

Motor Voltage _____ Motor RLA _____ Chiller LRA Rating _____

Actual Line Voltages: Starter/VFD _____ Oil Pump _____ Controls/Oil Heater _____

Verify 6-in. clearance surrounding all Starter/VFD enclosure louvers: Yes No

Visually inspect down through top of power module for debris: Yes No N/A

Starter/VFD Manufacturer _____ Starter/VFD Nameplate I.D. Number _____

Starter/VFD Serial Number _____ Starter/VFD Nameplate Input Rating _____

Mfd in _____ on _____

FIELD-INSTALLED STARTER/VFD ONLY:

Check continuity T1 to T1, etc. (Motor to VFD, disconnect motor leads T1, T2, T3). Do not megger Starter/VFD; disconnect leads to motor and megger the leads.

MEGGER MOTOR	"PHASE TO PHASE"			"PHASE TO GROUND"		
	T1-T2	T1-T3	T2-T3	T1-G	T2-G	T3-G
10-Second Readings						
60-Second Readings						
Polarization Ratio						

RECORD THE FOLLOWING POWER ON CHECKS:

Line Voltage: Phase - Phase	A-B:	B-C:	A-C:
Line Voltage: Phase - Ground	A-G:	B-G:	C-G:

What type and size of transformer supplies power to the unit?

Delta with No Ground _____

Corner Grounded Delta _____

Wye with Center Ground _____

Wye with No Ground _____

Transformer Size _____ kVa

CUT ALONG DOTTED LINE

CUT ALONG DOTTED LINE

CONTROLS: SAFETY, OPERATING, ETC.

Perform Controls Test (Yes/No) _____

CAUTION
COMPRESSOR MOTOR AND CONTROL PANEL **MUST** BE PROPERLY AND INDIVIDUALLY
CONNECTED BACK TO THE EARTH GROUND IN THE STARTER (IN ACCORDANCE WITH
CERTIFIED DRAWINGS).

Yes _____

WATER/BRINE PUMP CONTROL: Can the Carrier controls independently start the pumps?

Condenser Water Pump Yes No
Chilled Water Pump Yes No

RUN MACHINE: Do these safeties shut down machine?

Condenser Water Flow Yes No
Chilled Water Flow Yes No
Pump Interlocks Yes No

NOTE: This can be accomplished through BMS interlock with Carrier controls (typically via BACnet or Modbus) or hardwire connections to pumps. Chiller **MUST** maintain pump control for freeze protection purposes. If answer to above is "No" the customer must sign off that this is not installed and a copy must be kept with the startup paperwork since this can result in loss of warranty coverage.

INITIAL START:

Line up all valves in accordance with instruction manual: _____

Start water pumps and establish water flow _____

Oil level OK and oil temperature OK _____ Check oil pump rotation-pressure _____

Check compressor motor rotation (motor end sight glass) and record: Clockwise _____

Restart compressor, bring up to speed. Shut down. Any abnormal coastdown noise? Yes* No

*If yes, determine cause.

START MACHINE AND OPERATE. COMPLETE THE FOLLOWING:

- A: Trim charge and record under Charge Refrigerant section.
- B: Take at least two sets of operational log readings and record.
- C: After machine has been successfully run and set up, shut down and mark shutdown oil and refrigerant levels.
- D: Give operating instructions to owner's operating personnel. Hours Given: _____ Hours
- E: Call your Carrier factory representative to report chiller start-up.

SIGNATURES:

CARRIER TECHNICIAN _____ DATE _____

CUSTOMER REPRESENTATIVE _____ DATE _____

19XR PIC 6 SET POINT TABLE CONFIGURATION SHEET

DESCRIPTION	RANGE	UNITS	VALUE
Cooling ECW set point	15.0 to 120.0	°F	
Cooling LCW set point	10.0 to 120.0	°F	
Heating ECDW set point	63.0 to 150.0	°F	
Heating LCDW set point	63.0 to 150.0	°F	
Ice Build set point	15.0 to 60.0	°F	
Base Demand Limit	10.0 to 100.0	%	
EWT Control Option	DSABLE/ENABLE	—	

HMI Software Version Number: _____

HMI Controller Identification: BUS: _____ ADDRESS: _____

19XR PIC 6 TIME SCHEDULE CONFIGURATION SHEET PERIOD 1

	DAY FLAG								OCCUPIED TIME				UNOCCUPIED TIME			
	M	T	W	T	F	S	S	H								
Period 1:																
Period 2:																
Period 3:																
Period 4:																
Period 5:																
Period 6:																
Period 7:																
Period 8:																

19XR PIC 6 TIME SCHEDULE CONFIGURATION SHEET PERIOD 2

	DAY FLAG								OCCUPIED TIME				UNOCCUPIED TIME			
	M	T	W	T	F	S	S	H								
Period 1:																
Period 2:																
Period 3:																
Period 4:																
Period 5:																
Period 6:																
Period 7:																
Period 8:																

19XR PIC 6 TIME SCHEDULE CONFIGURATION SHEET PERIOD 3

	DAY FLAG								OCCUPIED TIME				UNOCCUPIED TIME			
	M	T	W	T	F	S	S	H								
Period 1:																
Period 2:																
Period 3:																
Period 4:																
Period 5:																
Period 6:																
Period 7:																
Period 8:																

CUT ALONG DOTTED LINE

CUT ALONG DOTTED LINE

**19XR PIC 6 ISM CONFIGURATION TABLE (CONF_ISM) CONFIGURATION SHEET
(Must be configured for all fixed speed machines with ISM, Benshaw MX3, freestanding VFD)**

DESCRIPTION	RANGE	UNITS	DEFAULT	VALUE
Communication Timeout	0 to 255	sec	10	
Starter Type 0 = Full Volt 1 = Reduced Volt 2 = Solid State 3 = FS VFD	0 to 3		0	
Single Cycle Dropout	DSABLE/ENABLE		DSABLE	
Motor Rated Load Amps	10 to 5000	amps	200	
Motor Rated Kilowatts	1000 to 8000	kW	1500	
Motor Locked Rotor Trip	100 to 65535	amps	1000	
Locked Rotor Start Delay	1 to 10	cycles	5	
Starter LRA Rating	100 to 65535	amps	2000	
Motor Rated Line Voltage	200 to 13800	volts	460	
Current Imbal Threshold	5 to 100	%	15	
Voltage Imbal Threshold	1 to 10	%	5	
Motor Current CT Ratio:1	3 to 1000		100	
Volt Transformer Ratio:1	1 to 115		1	
Current Imbal Persist	1 to 10	sec	5	
Voltage Imbal Persist	1 to 10	sec	5	
Line Frequency Faulting	DSABLE/ENABLE		DSABLE	
Frequency (NO = 50 Hz, YES = 60 Hz)	NO/YES		NO	
Ground Fault Protection	DSABLE/ENABLE		ENABLE	
Ground Fault Current	1 to 25	amps	15	
Ground Fault Persistence	1 to 10	cycles	5	
Ground Fault Start Delay	1 to 20	cycles	10	
Ground Fault CT Ratio:1	150 to 150		150	
Overvoltage Threshold	105 to 115	%	115	
Undervoltage Threshold	85 to 95	%	85	
Over Under Volt Persist	1 to 10	sec	5	
Under Volt Start Delay	1 to 4	sec	1	

**19XR PIC 6 General VFD Config (CFGGEVFD) CONFIGURATION SHEET
(Must be configured for all machines with VFD)**

DESCRIPTION	RANGE	UNITS	DEFAULT	VALUE
VFD Current Limit	0 to 99999	amps	250	

UM VFD Configuration

DESCRIPTION	RANGE	UNITS	DEFAULT	VALUE
Compressor Speed 100%	47 to 110	Hz	50	
Rated Line Voltage	200-13800	V	460	
Motor Nameplate Current	10 to 2000	AMPS	200	
Motor Rated Load Current	10 to 2000	AMPS	200	
Motor Nameplate Voltage	200 to 13800	Volts	460	
Motor Nameplate RPM	1500 to 3600	rpm	3000	
Motor Nameplate KW	0 to 5600	KW	1500	
Skip Frequency 1	0.0 to 102.0	Hz	102	
Skip Frequency 2	0.0 to 102.0	Hz	102	
Skip Frequency 3	0.0 to 102.0	Hz	102	
Skip Frequency Band	0.0 to 102.0	Hz	0	
Motor Rated Load Current	10 to 1500	AMPS	200	
Increase Ramp Time	5 to 60	sec	30	
Decrease Ramp Time	5 to 60	sec	30	
Line Voltage Imbalance%	1 to 10	%	10	
Line Volt Imbalance Time	1 to 10	sec	10	
Line Current Imbalance%	5 to 40	%	40	
Line Current Imbal Time	1 to 10	sec	10	
Motor Current Imbalance%	5 to 40	%	40	
Motor Current Imbal Time	1 to 10	sec	10	
Single Cycle Dropout	0 to 1		0	
PWM Switch Frequency 0=2KHZ, 1=4KHZ	0 to 1		0	

19XR PIC 6 OPTION CONFIGURATION TABLE (CONF_OPT) CONFIGURATION SHEET

DESCRIPTION	RANGE	UNITS	DEFAULT	VALUE
CONF_OPT	DSABLE/ENABLE		ENABLE	
Auto Restart	DSABLE/ENABLE		DSABLE	
Swift Restart Option	DSABLE/ENABLE		ENABLE	
Gas Torque Factor	0.25 to 3		1.00	
Guide Vane/SRD Factor	0.7 to 1.2		0.95	
Power Recovery Timeout	0 to 60	min	15.0	
Common Sensor Option	DSABLE/ENABLE		DSABLE	
EC/HC Valve Option 0=No, 1=Cont., 2=On/Off, 3=mA			0	
EC/HC Valve Selection 0=Disable, 1=Surge, 2=Low Load, 3=Comb			0	
EC/HG VLV Open IGV1 Pos	5 to 10	%	5	
EC/HG VLV Close IGV1 Pos	1.5 to 35	%	10	
EC/HG VLV Low Load DB	0.5 to 2	^F	1.0	
HPR VLV Option	DSABLE/ENABLE		DSABLE	
HPR VLV Delta Pos 0%	0 to 85	PSI	25	
HPR VLV Delta Pos 100%	0 to 85	PSI	50	
HPR VLV Min Output	0 to 100	%	0.0	
HPR VLV Deadband	0 to 10		1.0	
Tower Fan High Setpoint	55 to 105	°F	75	
Refrig Leakage Option	DSABLE/ENABLE		DSABLE	
Refrig Leakage Alarm mA	4 to 20	mA	20	
Oil Cooler EXV Option	DSABLE/ENABLE		DSABLE	
Oil Temp High Threshold	100 to 140	°F	122	
Oil Temp Low Threshold	90 to 130	°F	113	
Customer Alert Option	DSABLE/ENABLE		DSABLE	
Ice Build Option	DSABLE/ENABLE		DSABLE	
Ice Build Recycle	DSABLE/ENABLE		DSABLE	
Ice Build Termin Source 0=Temp, 1=Contact, 2=Both			0	
Vapor Source SV Option	DSABLE/ENABLE		DSABLE	
Vapor Source SV Delay	0 to 10	min	5	
Evap Liquid Temp Opt	DSABLE/ENABLE		ENABLE	
Evap App Calc Selection 0=Sat Temp, 1=Ref Temp			1	

19XR PIC 6 OPTION CONFIGURATION TABLE (CONF OPT2) CONFIGURATION SHEET

DESCRIPTION	RANGE	UNITS	DEFAULT	VALUE
IOB3 Option	No/Yes		No	
IOB4 Option	No/Yes		No	
Water Pressure Option 0=No 1=WTR Flow PD TRD (pressure transducers) 2=WTR Flow PD TRM (4-20 mA differential water flow pressure transmitter)			0	
Water Flow Measurement 0=No 1=WTR Flow MTR (4-20 mA water flow sensors) 2=WTR Flow PD (based on water pressure drop measurement)			0	
Free Cooling Option	No/Yes		No	
Water Flow Determination 0=Sat Temp, 1=Flow Switch, 2=WTR Flow PD				
Marine Option	Disable/Enable	Disable		

CUT ALONG DOTTED LINE

CUT ALONG DOTTED LINE

19XR PIC 6 SRD TABLE CONFIGURATION SHEET

DESCRIPTION	RANGE	UNITS	DEFAULT	VALUE
Diffuser Option	DSABLE/ENABLE		DSABLE	
SRD IGV Offset Select	1 to 5		3	
Low Lift Profile Select	1 to 5		3	
Diffuser Full Span mA	15.0 to 22.0	mA	18.0	
GV 1 Pos @ 25% Load	0.0 to 83.0	%	6.4	
GV 1 Pos @ 50% Load	0.0 to 83.0	%	22.9	
GV 1 Pos @ 75% Load	0.0 to 83.0	%	41.3	
SRD POS @ 25% Load	0.0 to 100.0	%	73.5	
SRD POS @ 50% Load	0.0 to 100.0	%	35.1	
SRD POS @ 75% Load	0.0 to 100.0	%	19.5	
High Lift @ 100% Load	0.0 to 100.0	^F	67.5	
High Lift @ 25% Load	0.0 to 100.0	^F	52.4	
Low Lift @ 25% Load	0.0 to 100.0	^F	27.2	
Peak Detection Threshold	0.0000 to 5.0000	Volts	0.0000	

19XR PIC 6 PROTECTIVE LIMIT TABLE CONFIGURATION SHEET

DESCRIPTION	RANGE	UNITS	DEFAULT	VALUE
Evap Approach Alert	0.5 to 15.0	^F	5.0	
Cond Approach Alert	0.5 to 15.0	^F	6.0	
Cond Press Override Low	90.0 to 157.0	psi	140.0	
Cond Press Override High	200.0 to 265.0	psi	250.0	
Cond Press Cutout Low	160.0 to 165.0	^F	160.0	
Cond Press Cutout High	270.0 to 275.0	^F	275.0	
Evap Override Delta T	2.0 to 5.0	^F	3.0	
Evap Refrig Trippoint	0.0 to 40.0	^F	33.0	
High Evap Press Override	90 to 157	psig	140	
High Evap Press Cutout	160 to 170	^F	165	
Condenser Freeze Point	-20.0 to 35.0	^F	34.0	
Comp Discharge Alert	125.0 to 200.0	^F	200.0	
Comp Motor Temp Override	150.0 to 200.0	^F	200.0	
Comp Bearing Temp Alert	155.0 to 175.0	^F	175.0	
Comp Bearing Temp Trip	175.0 to 185.0	^F	185.0	
Comp Bearing Alert XR6/7	185.0 to 210.0	^F	210.0	
Comp Bearing Trip XR6/7	210.0 to 220.0	^F	220.0	
Minimum Brine LWT	10.0 to 34.0	^F	34.0	
Heating LWT Protect Set	41.0 to 50.0	^F	42.8	
Evap Flow Delta P Cutout	0.5 to 50.0	psi	5.0	
Cond Flow Delta P Cutout	0.5 to 50.0	psi	5.0	
Cond Hi Flow DP Limit	0.5 to 50.0	psi	50.0	
Cond Hi Flow Alarm	DSABLE/ENABLE		DSABLE	

19XR PIC 6 SERVICE PARAMETERS TABLE CONFIGURATION SHEET

DESCRIPTION	RANGE	UNITS	DEFAULT	VALUE
Atmospheric Pressure	8 to 15	psi	14.5	
GV1 Travel Limit	30 to 100	%	80	
GV1 Closure at Startup	0 to 40	%	4	
Controlled Fluid DB	0.5 to 2.0	^F	1	
Derivative EWT Gain	1.0 to 3.0		2.0	
Proportional Dec Band	2.0 to 10.0		6	
Proportional Inc Band	2.0 to 10.0		6.5	
Maximum GV Movement	2 to 4	%	2	
Demand Limit At 20 mA	10 to 100	%	40	
Demand Limit Prop Band	3.0 to 15.0	%	10.0	
Amps or KW Ramp per Min.	5.0 to 20.0		10.0	
Temp Ramp Rate per Min.	1 to 10	^F	3	
Recycle Shutdown Delta T	0.5 to 4.0	^F	1	
Recycle Restart Delta T	2.0 to 10.0	^F	5.0	
Damper Valve Act Delay	0 to 20	min	5	
Damper Valve Close DB	2.0 to 10.0	^psi	5.0	
Damper Valve Open DB	10.0 to 20.0	^psi	13.0	
Damper Action Delta T	4.0 to 10.0	^F	7.0	
Oil Press Verify Time	15 to 300	sec	40	
Soft Stop Amps Threshold	40 to 100	%	70	
Water Flow Verify Time	0.5 to 5.0	min	5.0	
Power Calibration Factor	0.900 to 1.000		0.97	
Enable Excessive Starts	NO/YES		NO	
Oil Stir Cycle (19XR6/7) 0 = No stir, 1 = 30s/30m 2 = 1m/4hr, 3 = Comb 0&1	0 to 3		1	

19XR PIC 6 GEN_CONF TABLE CONFIGURATION SHEET

DESCRIPTION	RANGE	UNITS	DEFAULT	VALUE
Stop to Start Delay	1 to 15	min	2	
Start to Start Delay	4 to 45	min	15	
Demand Limit Type 0 = Base Demand 1 = 4 to 20 mA	0 to 1		0	
Pulldown Ramp Type 0 = Temp 1 = Load	0 to 1		1	
Demand Limit Source 0 = Amps 1 = KW	0 to 1		0	

19XR PIC 6 RESETCFG TABLE CONFIGURATION SHEET

DESCRIPTION	RANGE	UNITS	DEFAULT	VALUE
Temp Reset Type 0 = No 1 = 4 to 20 mA 2 = Remote Temp 3 = Water DT	0 to 3		0	
Degrees Reset At 20 mA	-30.0 to 30.0	^F	10.0	
Maximum Deg Temp Reset	-30.0 to 30.0	^F	10.0	
Remote Temp Full Reset	-40.0 to 245.0	^F	65.0	
Remote Temp No Reset	-40.0 to 245.0	^F	85.0	
Deg Reset Water DT Full	-30.0 to 30.0	^F	10.0	
Controlled DT Full Reset	0.0 to 15.0	^F	0.0	
Controlled DT No Reset	0.0 to 15.0	^F	10.0	

CUT ALONG DOTTED LINE

CUT ALONG DOTTED LINE

19XR PIC 6 CONF_MS MASTER SLAVE TABLE CONFIGURATION SHEET

DESCRIPTION	RANGE	UNITS	DEFAULT	VALUE
Slave Address	1 to 236		2	
Master/Slave Select 0 = Disable 1 = Master 2 = Slave	0 to 2		0	
Chiller Connection Type 0 = Parallel 1 = Series	0 to 1		0	
Middle Sensor Option	YES/NO		YES	
Master Lead Lag Select	0 to 1		0	
Series Counter Flow	NO/YES		NO	
Master per Capacity	25 to 75	%	50	
Lag Shutdown Threshold	25 to 75	%	50	
Prestart Fault Timer	2 to 30	min	5	
Lead Unload Threshold	50 to 100	%	100	
Lead/Lag Balance Delta	40 to 400	hr	168	
Lag Start Timer	2 to 30	min	10	
Lag Stop Timer	2 to 30	min	10	
Lead Pulldown Time	0 to 60	min	0	
Lag Minimum Running Time	0 to 150	min	0	
Lag Run Delta T	0 to 10.0	^F	3.0	
Lag Off Delta T	0 to 10.0	^F	1.8	

19XR PIC 6 CONNECT - BMS PROTOCOL TABLE CONFIGURATION SHEET

DESCRIPTION	RANGE	UNITS	DEFAULT	VALUE
Modbus Configuration				
Port J8 Option 0=None, 1=BACnet MS/TP, 2=Modbus RTU	0 to 2		0	
Modbus TCP Enable	DSABLE/ENABLE		DSABLE	
Modbus TCP Port Number	0 to 1024		502	
Modbus Server UID	NO/YES		NO	
Modbus Metric Unit	0 to 1024		502	
Modbus RTU Parity Option 0=No, 1=Odd, 2=Even, 3=Low, 4=High	0 to 4		0	
Modbus RTU Stop Bit 1= 1 Bit, 2= 2 Bits	0 to 2		2	
Modbus RTU Baudrate 0=9600, 1=19200, 2=38400	0 to 2		0	
Modbus Litte Endian	NO/YES		NO	
Modbus Real Type	NO/YES		NO	
BACnet Configuration				
BACnet/IP Enable	DSABLE/ENABLE		ENABLE	
BACnet Metric Unit	NO/YES		YES	
BACnet Network	1 to 9999		1600	
BACnet Identifier	0 to 9999999		1600001	
BACnet Schedule Enable	DISABLE/ENABLE		DISABLE	
MS/TP Mac address	1 to 127		1	
MS/TP Baud rate 0=9600, 1=19200, 2=38400, 3=57600, 4=76800, 5=115200	0 to 5		2	
MS/TP Max Master	0 to 127		3	
MS/TP Max Info Frames	1 to 255		5	

19XR PIC 6 CFGSURGE SURGE CORRECTION CONFIG TABLE CONFIGURATION SHEET

DESCRIPTION	RANGE	UNITS	DEFAULT	VALUE
Surge Line Configuration 0=PR, 1=Delta T	0 to 1		0	
IGV1 Pos Configuration 0-Degree, 1=Percentage	0 to 1		0	
Surge Delta Tmax	0.0 to 150.0	°F	70.0	
Surge Delta Tmin	0.0 to 150.0	°F	45.0	
PR at Full Load Opening	1.0000 to 5.0000		3.0000	
PR at Min. Opening	1.0000 to 5.0000		1.5000	
IGV1 Full Load Open Deg	90 to 120.0	degree	88.0	
Sound Ctrl IGV1 Open Deg	10.0 to 40.0	degree	27.0	
IGV1 Minimum Open Deg	0.0 to 10.0	degree	2.0	
IGV1 Actuator Max Deg	90.0 to 120.0	degree	109.0	
Surge Line Offset	1.0 to 3.0	°F	2.0	
Surge Line Lower Deadband	0.5 to 3.0	°F	1.5	
Surge Line Upper Deadband	0.1 to 3.0	°F	1.5	
Surge Line Shape Factor	-1.000 to 0.000		-0.010	
Sound Line Shape Factor	0.000 to 1.000		0.010	
Surge Line Speed Factor	0.00 to 3.00		2.00	
Surge Delay Time	0 to 120	sec	15	
Surge Time Period	7 to 10	min	8	
Surge Delta Amps %	5 to 40	%	20	
Rampdown Factor	0 to 1	10	0	
GV1 Close Step Surge	1.0 to 3.0	%	2.0	
VFD Speed Step Surge	1.0 to 5.0	%	1.5	
EC Valve Step Surge	1.0 to 10.0	%	4.0	
Surge Profile Step	0 to 2	°F	1	
Surge Profile Offset	0.0 to 5.0	°F	0.0	
High Efficiency Mode	DSABLE/ENABLE		DSABLE	
GV Jumpover Option	DSABLE/ENABLE		DSABLE	

19XR PIC 6 CTRL_ID CONTROL IDENTIFICATION TABLE CONFIGURATION SHEET

DESCRIPTION	RANGE	UNITS	DEFAULT	VALUE
CCN Element Number	0 to 239		1	
CCN Bus Number	0 to 239		0	
CCN Baud Rate	9600, 19200, 38400		9600	
Device Description — 19XRPIC6				
Location Description (User-defined 24-digit character string)				
Software Part Number: SCG-SR-2-20S200200				
Serial Number =				

19XR PIC 6 LQBP - LOW LOAD CONTROL IDENTIFICATION TABLE CONFIGURATION SHEET

DESCRIPTION	RANGE	UNITS	DEFAULT	VALUE
ECO LBP VLV Option	DSABLE/ENABLE		DSABLE	
ECO LBP VLV Limit	0 to 100	%	100	
DSH Deadband for LBP	0 to 20	°F	2	
ECO LBP VLV EVap Appro	1 to 20	°F	5	
Dynamic Demand Limit	DSABLE/ENABLE	min	DSABLE	
Ignore DDL Time	0 to 60		30	
LCW at Selection Point	32 to 86	°F	45	
LCDW at Selection Point	59 to 113	°F	95	
100% Lift Demand Limit	10 to 100	%	100	
Middle Lift Percent	40 to 80	%	60	
Middle Lift Demand Limit	0 to 100	%	80	
20% Lift Demand Limit	0 to 100	%	45	
LCW at Selection Point	32 to 86	°F	45	
LCDW at Selection Point	59 to 113	°F	95	

CUT ALONG DOTTED LINE

CUT ALONG DOTTED LINE

DISPLAY AND ALARM SHUTDOWN STATE RECORD SHEET

PRIMARY MESSAGE: _____ DATE: _____ TIME: _____
SECONDARY MESSAGE: _____ COMPRESSOR ONTIME: _____

CHW IN <input type="text"/>	CHW OUT <input type="text"/>	EVAP REF <input type="text"/>
CDW IN <input type="text"/>	CDW OUT <input type="text"/>	COND REF <input type="text"/>
OILPRESS <input type="text"/>	OIL TEMP <input type="text"/>	AMPS % <input type="text"/>

COMMUNICATION MESSAGE _____

DISPLAY AND ALARM SHUTDOWN STATE RECORD SHEET

PRIMARY MESSAGE: _____ DATE: _____ TIME: _____
SECONDARY MESSAGE: _____ COMPRESSOR ONTIME: _____

CHW IN <input type="text"/>	CHW OUT <input type="text"/>	EVAP REF <input type="text"/>
CDW IN <input type="text"/>	CDW OUT <input type="text"/>	COND REF <input type="text"/>
OILPRESS <input type="text"/>	OIL TEMP <input type="text"/>	AMPS % <input type="text"/>

COMMUNICATION MESSAGE _____

CUT ALONG DOTTED LINE

CUT ALONG DOTTED LINE