

**Southeast Toyota Distributors, LLC
Accessory Installation Instructions**

**2019 4Runner
Gunner 20" Wheel**

Year & Model:	2019 4Runner
Part Number:	00041-89160
Accessory Code:	AC1010
PIO / DIO:	PIO / DIO
Business Partner:	J58

Conflicts

Note: None

General Applicability

<u>Fits Models:</u>
Note: 2019 4Runner Models

Additional Items Required For Installation

Item#	Description:
1.	(1) PTR25-89150-Trim Kit
2.	(1) Balance weights stick on tape
3.	(1) Torque Audit Sheet (PIO, Only) Note: Torque Audit Sheet is required for PIO installation if Atlas Copco automated torque equipment is NOT being used. Torque Sheet will be used as part of PIO Atlas Copco periodic checks as scheduled intervals.

Sequence of Application

Item#	Accessory:
1	• PTR25-89150 – Trim Kit

SPECIALNOTE: Installation Sequences

After TMS & Safety mandated preparatory steps have been taken, the installation sequence is the suggested method for completing the accessory installation. In some instances the suggested sequence is written for one associate to install & in others the sequence is given as part of a team accessory installation. Unless otherwise stated in the document, the associates may perform the installation steps in any order to make the installation as efficient as possible while maintaining consistent quality.

Recommended Too

Safety Items	
Safety Glasses	
Seat Protection	
Special Tools	
Foot Brake Application Tool	
Installation Tools	
Wheel Balancing Machine	Hunter 9700 or Equivalent
Tire Mounting Machine	Hunter or Corgi
Torque Wrench	0-100-lbf-ft (135 N-m)
Socket	0-75-lbf-in (8.5 N-m)
Socket	21mm Deep Well
Special Chemicals	12mm Thin Wall, Deep Well
Tire Lube	
Cleaner	3M Prep Sol-70 or equiv.

Legend

STOP: Damage to the vehicle may occur. Do not proceed until process has been complied with.

OPERATOR SAFETY: Use caution to avoid risk of injury.

CAUTION: A process that must be carefully observed in order to reduce the risk of damage to the accessory/vehicle and to ensure a quality installation.

TOOLS & EQUIPMENT: Used in Figures calls out the specific tools and equipment recommended for this process.

REVISION MARK: This mark highlights a change in installation with respect to previous issue.

SAFETY TORQUE: This mark indicates that torque is related to safety.

Table of Contents

- I. Preparation.....1-5
 - a.) Table of Contents.....2
 - b.) Kit/Hardware Bag Contents.....3
 - c.) Parts for Installation.....4
 - d.) Service & Warranty Information.....5

- II. Procedures
 - a.) Vehicle Preparation6
 - b.) Remove Tire Pressure Monitor Valve Sub-Assembly.....7
 - c.) Install Tire Pressure Monitor Valve.....8
 - d.) Tire Mounting.....9
 - e.) Wheel Mounting10
 - f.) Vehicle Wheel / Tire Installation.....11
 - g.) Center Cap Installation.....11

- III. Accessory Function Check.....12
- IV. Warranty Statement.....13-14

Kit/Hardware Bag Contents:

Item #	Quantity	Description
1.	1	Alloy Wheel
2.	1 per Wheel	Center cap Black – 00041-89600-01

Parts for Installation:

Care must be taken when installing this accessory to ensure damage does not occur to the vehicle. The installation of this accessory should follow approved guidelines to ensure a quality installation. These guidelines can be found in the "Accessory Installation Practices" document.

This document covers such items as:

- Vehicle Protection (use of covers and blankets, cleaning chemicals, etc.).
- Safety (eye protection, re-checking torque procedure, etc.).
- Vehicle Disassembly/ Reassembly (panel removal, part storage, etc.).
- Electrical Component Disassembly/Reassembly (battery disconnection, connector removal, etc.).

Item #	Quantity	Description
1.	1	Alloy Wheel
2.	1 per Wheel	Center cap Black



Service & Warranty Information:

Image Key	Parts information		Warranty Information	
	Part Number	Description	Warranty Time	Labor Op. Code
A	00041-89160	4Runner 20" Black Gunner Wheel	0.5	AWH011
B	00041-89600-01	1pc Black Center Cap	0.2	AWH021
N/A	00041-89600-02	6pc 12mm Mag Lug	N/A	N/A

Note: Combo Code A, AA, or AAA applicable to AWH011 for additional 0.3 hours per wheel replaced

If you are a dealer located outside of the Southeast Region, please contact the SET Accessory Warranty Department at (888) 851-2722 or email Accessory.Warranty@SEToyota.com for claim payment instructions.

Image:

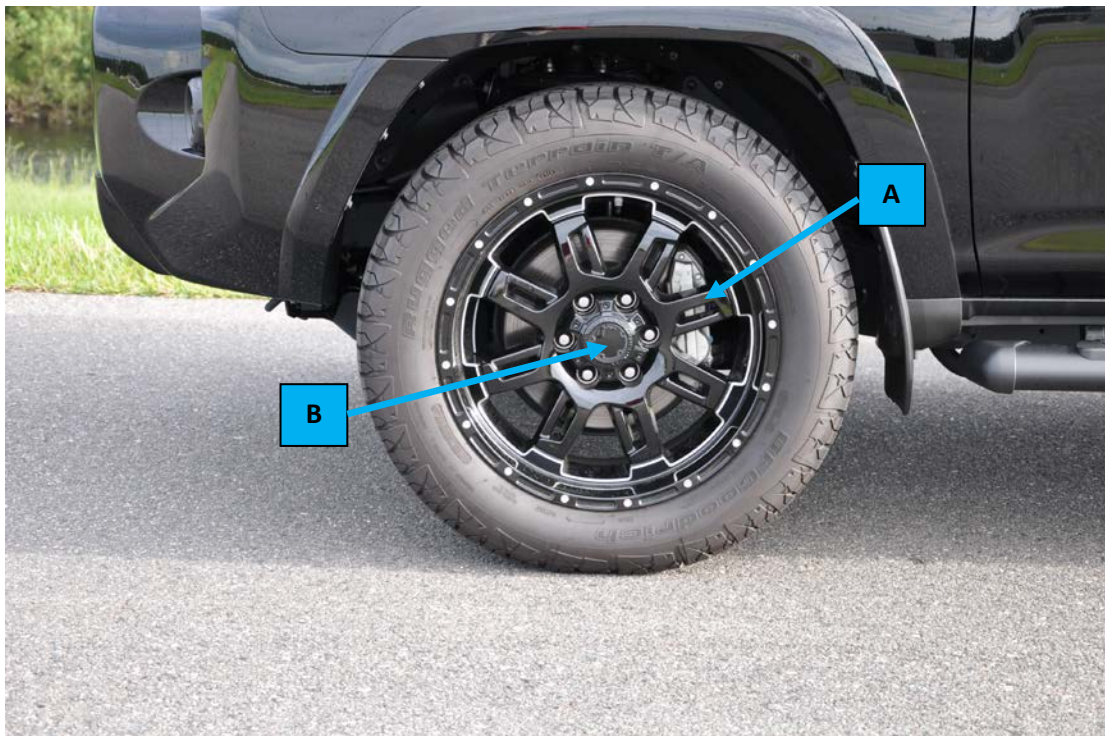

1. Vehicle Preparation.

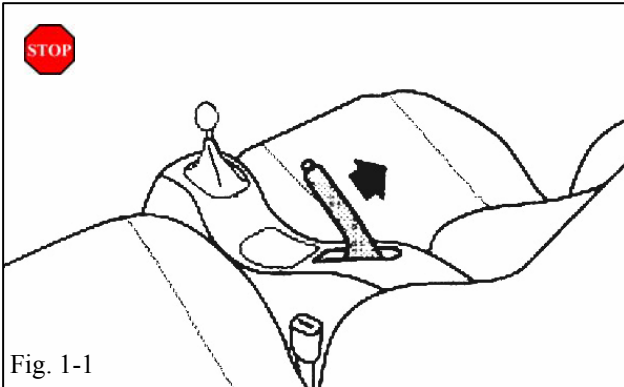

STOP (a) Firmly apply parking brake. (Fig. 1-1)

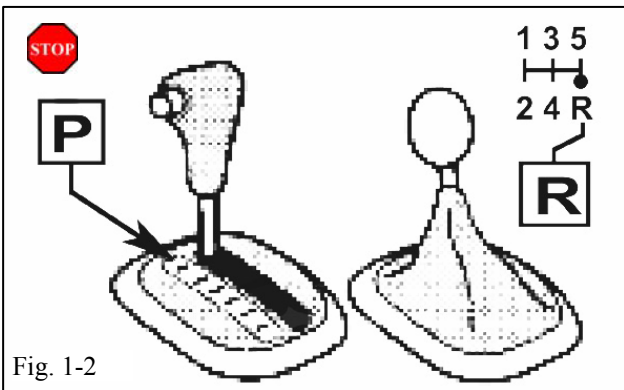

STOP (b) Put transmission in "P" (automatic) or reverse (manual). (Fig. 1-2) Lift vehicle.

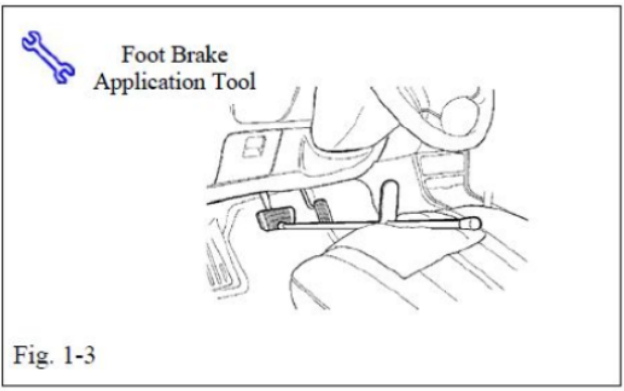

(c) Add seat protection (blanket) and apply foot brake using foot brake application tool. (Fig. 1-3) (Optional Step)

Procedure

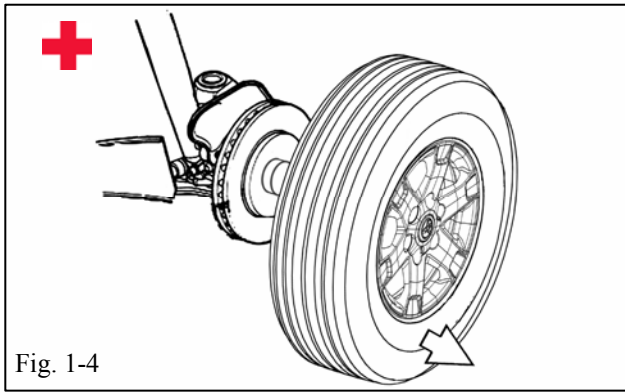

- +** (d) Remove OE wheel and tire assemblies from the vehicle. Wear safety glasses while removing wheels. (Fig. 1-4)

NOTE: Keep Factory Lug Nuts to Reinstall Wheel.

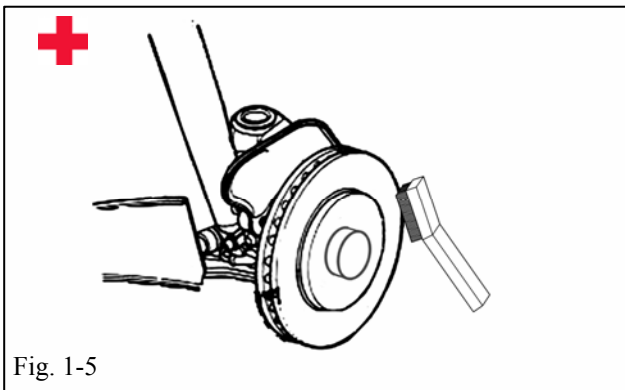

- +** (e) (Dealer Installation Only, if applicable)
Remove any corrosion on the mounting surface of the vehicle with a wire brush. Wear safety glasses to protect against dust. Fig. 1-5

2. Remove Tire Pressure Monitor Valve Sub-assembly.

- +** (a) Remove the valve core and release pressure from the tire.
- (b) Remove the nut and washer and retain for reinstallation later. Let the pressure sensor drop inside the tire.
- (c) Carefully separate the upper tire bead from the wheel rim. (Fig. 2-1).

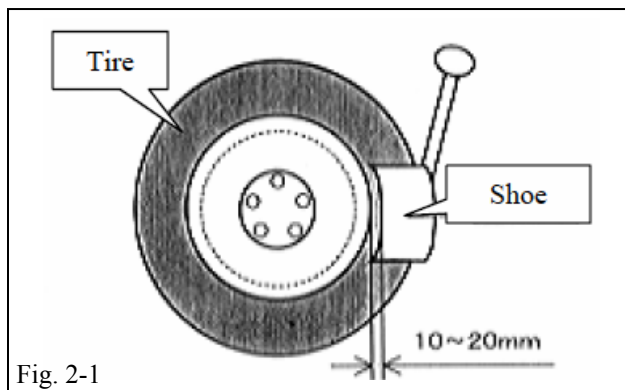

- STOP NOTE:** Be careful not to damage the tire pressure monitor due to interference between the sensor and tire bead.
- (d) Break the bead on the lower side & remove the sensor from the tire. Remove the bead on the lower side as in usual tire removal process.
- (e) Dismount OE tire from the OE wheel.

Procedure

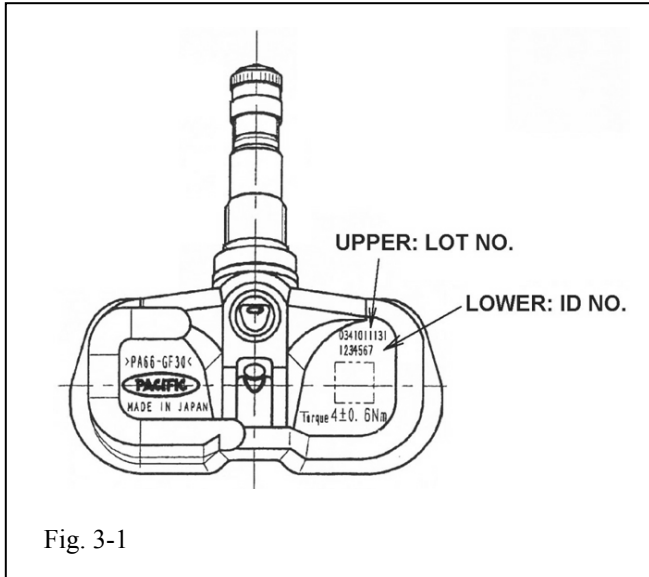

Fig. 3-1

3. Install Tire Pressure Monitor Valve Sub-assembly to Accessory Wheel.

- (a) Visually check that there is no deformation or damage on the tire pressure monitor valve sub-assembly.
- (b) Check that the rim is clean.
- (c) Change the original grommet to a new one if the grommet is damaged.



NOTE: Damaged grommet is NOT re-usable.

- (d) Check that the grommet, washer and nut are clean.

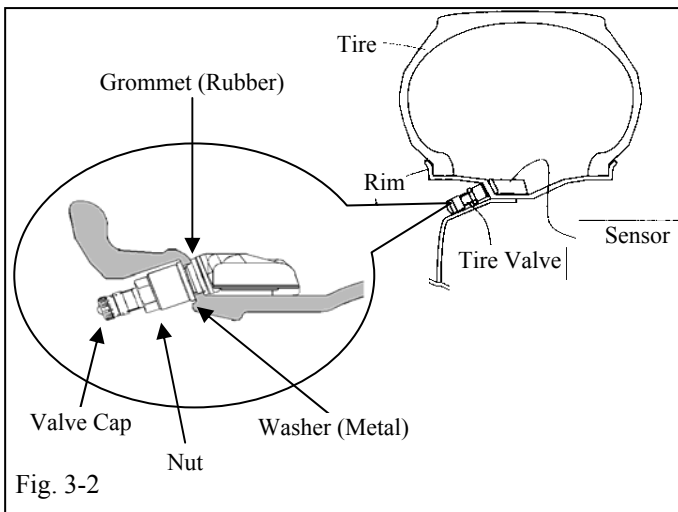

Fig. 3-2

- (e) Insert the tire pressure monitor valve sub-assembly into the valve installation hole from the inside of the rim and bring the valve stem to the outside. (Fig. 3-2).

- (1) Insert the tire pressure monitor valve sub-assembly so that "PACIFIC" mark is visible.



NOTE: Incorrect orientation of pressure monitor sub-assembly may cause damage and prevent signal transmission during high-speed running.

- (f) Install the washer and secure with the nut.



- (1) Tighten the nut to 4.0 N-m (35 lbf-in)

Procedure

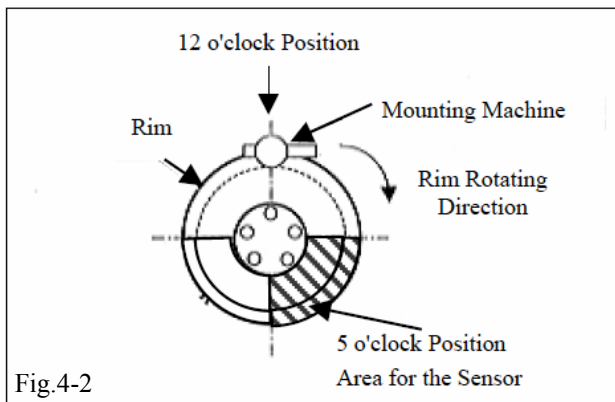
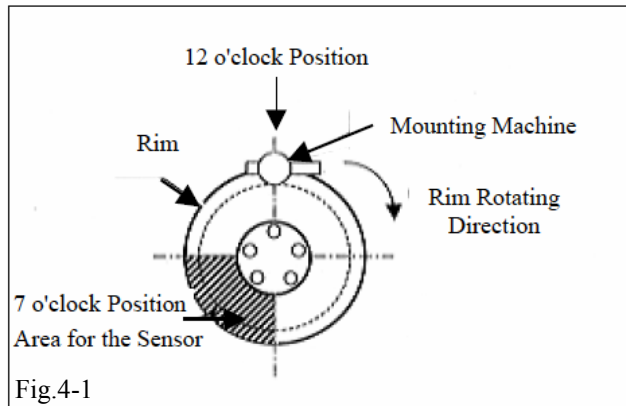
**Tire Mounting.**

4. (a) Use tire lube on tire bead and bead location on wheel prior to mounting the tire.

Note: Use Only Approved lubricant made for tire beads.

- (b) Position the wheel on the mounting machine with the sensor at ~ 7 o'clock position (shaded area in Fig. 4-1)

(1) Mount/dismount head is considered as 12 o'clock Position.

- (c) Mount the lower tire bead.

STOP NOTE: If the sensor is positioned outside this area, it generates interference with the tire bead, causing possible damage to the sensor.

- (d) Re-position the wheel on the mounting machine with the sensor at ~ 5 o'clock position (shaded area in Fig. 4-2)

- (e) Mount upper tire bead.

STOP NOTE: Make sure that the tire bead and tool does not interfere with the main body of the sensor and the bead does not clamp the sensor.

- +** (f) To seat tire bead, inflate tire beyond 33 PSI but not more than the maximum tire bead seat pressure indicated on the tire sidewall. If it is not indicated use 40 PSI as a limit. If tire bead is not seated when pressure registers 40 PSI, deflate the tire and re-inflate to seat the bead. Regulate tire pressure to New Tire pressure label value.

- !** (g) After inflating the tire, re-tighten the nut of tire pressure monitor valve sub-assembly to 4.0 +/- 0.6 N-m (35 +/- 5.3 lbf-in)

5. Wheel Mounting

- a. Mount wheel/tire on wheel balance machine and balance in DYNAMIC MODE. Enable the LOAD ROLLER, if applicable (enabling the load roller ensures proper bead seating). Road Force not to exceed 25lbs.
- b. Prior to mounting stick on weight type, wipe down the wheel with a clean lint-free dry-cloth. Ensure that location is clean and dry. Apply stick-on weights at perimeter location identified by dynamic balance machine as shown. Use rubber mallet, if required to achieve complete adhesion of stick-on weight.

Note: Max allowable weight is 10oz or no more than 5oz. per plane.

- c. Re-spin the wheel on the machine with LOAD ROLLER DISABLED (is applicable) and note the indicated remainder unbalance.

Plane Input

When inputting weight planes, center the rolling wheel of the inner dataset arm with the center of the Desired weight location.

Note: Hunter recommends temporarily placing a piece of the weight at the desired depths into the wheel, make a chalk mark on the wheel profile at the centers on the wheel and then bring the roller wheel to those marks when inputting planes)

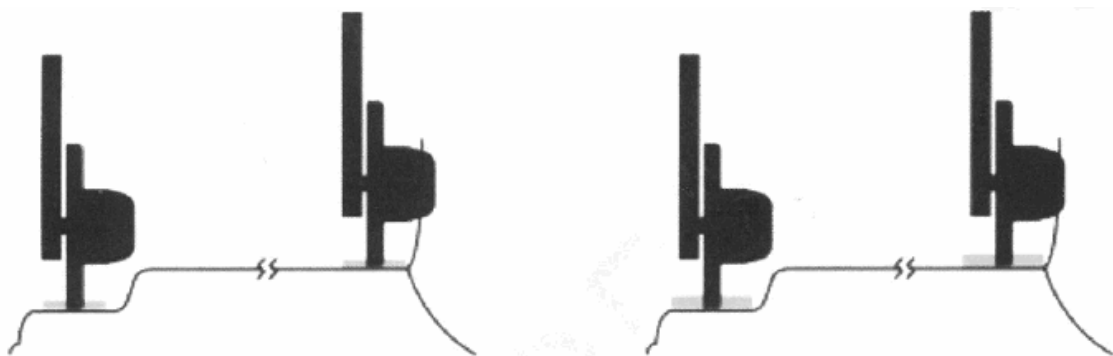

“Clearance to wheel brake caliper must exceed 3mm”

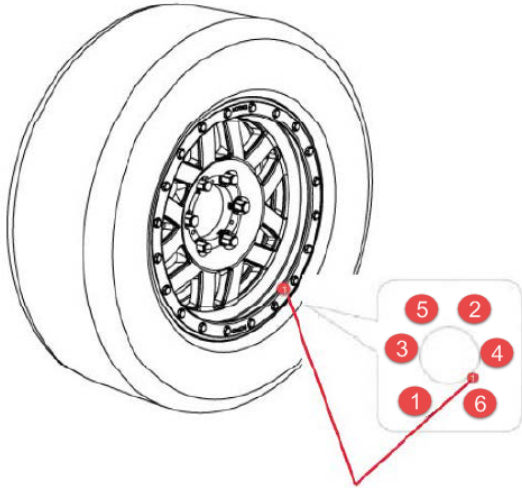

Tire Pressure Warning System (Valve Stem)
(Fig. 6-1.)

6. Vehicle Wheel / Tire Installation.

- (a) Install wheel/tire assembly on vehicle. *Note: During wheel installation, ensure the TPWS is located approximately in the 5 o'clock position.* Hand start the each lugnut, then starting to the left of the TPWS tighten in a clockwise star pattern. Tighten to **83 lbf-ft** using a torque wrench. (Fig. 6-1)
- (b) Lower the vehicle.
- (c) Tire pressure should be adjusted to the value recommended in the owner's manual for this vehicle. Install valve stem cap.



(d) Center Cap Installation

- (a) Align center cap to the wheel and install.
- (e) Install door jamb tire pressure label and upgrade tire sticker. (Fig. 7-1, 7-2)
- (f) Modification of wheel well & front bumper required. Reference PTR25-89150 - Trim Kit



(Fig. 7-1.)

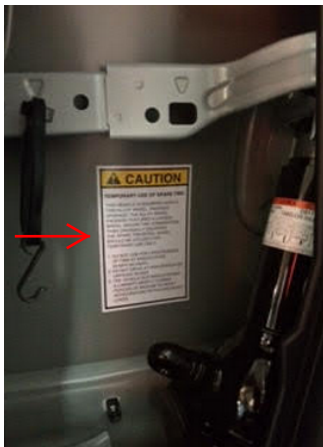

(Fig. 7-2.)

10. Print Warranty Statement & place in glove box., DIO only.

Checklist - these points **MUST** be checked to ensure a quality installation.

Check: _____

Look For: _____

Accessory Function Checks

✓ Inspect lug nuts

Ukz"lug nuts must be installed on each wheel

 ✓ Lugnut tightness

Tighten to : 5 lbf-ft torque

✓ Tire pressure

Low tire pressure warning system.

✓ Center caps

Correctly fitted

✓ Clean wheel & tire

Remove all stickers & marks on tires & wheels

Vehicle Function Checks

✓ Road test (for dealer installation only)

Excessive noise or wheels out of balance

✓ Warranty Statement

Place Warranty Statement in glove box, DIO only.

LIMITED WARRANTY – SOUTHEAST TOYOTA

SOUTHEAST TOYOTA DISTRIBUTORS, LLC ("we," "our" and "us") provides the following limited warranty on our accessories, excluding tires, ("Accessories" or "Accessory") installed on a Toyota. This limited warranty is not provided by and does not bind or provide benefit to the vehicle dealer, the manufacturer, or Toyota Motor Sales, U.S.A., Inc. This limited warranty does not apply to tires; please consult the tire manufacturer and/or its materials accompanying the vehicle for any warranty terms concerning tires. This limited warranty also does not apply to ToyoGuard Exterior Paint Sealant and ToyoGuard Interior Protector; please consult the ToyoGuard Limited Warranty Certificate for the warranty terms concerning those products.

SCOPE OF LIMITED WARRANTY:

A. Protection:

- i. **Accessories Installed by Southeast Toyota Distributors, LLC on a new Toyota vehicle.** We warrant that, for a period of 36 months or 36,000 miles, whichever occurs first, we will repair or replace (includes labor), free of charge, any defect in such an Accessory due to faulty material or workmanship, or, at our option, provide a full refund of the purchase price of the Accessory. The warranty period begins on the vehicle's In-Service Date, which is the first date the new vehicle is either delivered to an ultimate purchaser, leased, or used as a company car or demonstrator. Accessories installed by Southeast Toyota Distributors, LLC are identified on the vehicle's window sticker (Monroney Label).
- ii. **Accessories Installed by a Toyota Dealer on a Toyota vehicle.** We warrant that, for 12 months, regardless of mileage, from the date such an Accessory was installed on the vehicle or the remainder of the Toyota new vehicle warranty, whichever is longer, we will repair or replace (includes labor), free of charge, any defect in the Accessory due to faulty material or workmanship, or, at our option, provide a full refund of the purchase price of the Accessory. For a new vehicle, the warranty period begins on the vehicle's In-Service Date, which is the first date the new vehicle is either delivered to an ultimate purchaser, leased, or used as a company car or demonstrator.
- iii. **Accessories purchased from a Toyota Dealer but not installed by the Toyota Dealer.** We warrant that, for a period of 12 months, regardless of mileage, from the date the accessory was purchased, we will repair or replace (does not include labor), free of charge, any defect in the Accessory due to faulty material or workmanship, or, at our option, provide a full refund of the purchase price of the Accessory.

B. Limitation of Warranty. This limited warranty does not apply to, and we will not repair, replace, or reimburse you for: (1) wheel balancing and wheel alignments, except for one wheel balancing or alignment during the first 12 months or 12,000 miles, whichever occurs first, from the vehicle's In-Service Date, as defined above, (2) abrasions or dents, whatever their cause, and any failure or damage resulting directly or indirectly from accidents, collisions, impacts from foreign objects, fire, theft, larceny, explosion, malicious mischief, vandalism, civil commotion, riots, war, or any other similar causes, (3) any failure or damage resulting directly or indirectly from lightning, windstorms, hail, water, floods, subfreezing temperatures, airborne chemicals, tree sap, dust, salt, and any other environmental conditions or similar causes, (4) any failure or damage caused by: (a) a failure of any part, other than the Accessory, (b) any misuse, abuse, improper towing, negligence or lack of maintenance of the vehicle or Accessory, (c) the alteration, modification or repair of the Accessory by anyone other than persons expressly authorized by us to perform such alteration, modification or repair, or (d) the use of the vehicle for commercial purposes, competitive driving or racing, (5) any failure or damage, if the Accessory has not been installed according to instructions, (6) any failure or damage occurring outside of Canada, the United States of America, its territories or possessions, (7) except to the extent required by the state whose laws govern this limited warranty, any consequential, secondary, or unreasonable costs that may be suffered as a result of the need to repair or replace the Accessory, including without limitation any loss of use of the vehicle, road service, towing, storage charges, inconvenience, loss of wages and/or income, additional expense incurred, loss of transportation, rental car expense, or any derivative damage to persons or things other than the Accessory, including other parts of the vehicle, or (8) liability for damage to property or for injury to or death of any person, arising out of the operation, maintenance or use of your vehicle whether or not related to the covered Accessory.

C. Exclusive Remedy. If there is a valid claim under this limited warranty for a defect due to faulty material or workmanship in the Accessory, we will, at our option, either: (i) repair, (ii) replace or (iii) provide a full refund of the purchase price of the Accessory. We have no other obligations under this limited warranty. Refunds will be made to the vehicle owner. If the vehicle is leased, the refund will be made to the leasing company.

HOW TO MAKE A CLAIM: In the event of a warranty claim, please contact the nearest Toyota dealer to arrange for repairs. The dealership must receive our prior authorization before making repairs covered by this limited warranty. The dealer will contact Southeast Toyota Distributors, LLC at 1-888-851-2722, select option #5 (Warranty Department), then option #4 (Repairs), for instructions on processing a warranty claim, if they are not already familiar with the process. If you have any questions or concerns regarding repairs covered by this limited warranty, please contact our Customer Assistance Hotline at 1-800-301-6859.

OUR DISPUTE RESOLUTION PROGRAM: Your satisfaction is our highest priority. In keeping with that focus, in the event that an issue arises related to this Limited Warranty, we invite you to call our Customer Assistance Hotline at 1-800-301-6859 to discuss it. In most cases, we expect that a satisfactory resolution of your issue can be reached through engagement with that Department. If our Customer Loyalty Department is unable to resolve your issue to your satisfaction, we offer a dispute resolution program administered by the National Center for Dispute Settlement (NCDS) ("the Program"). The purpose of the Program is to resolve disputes in an informal setting before an impartial arbitrator. The Program is free of charge to you (although you must bear the cost of any expert witness or attorney you elect to employ). You are required to complete the Program before exercising rights or seeking remedies under the federal Magnuson-Moss Warranty Act, 15 U.S.C. § 2301 et seq. ("the Act"). If you choose to seek remedies that are not created by the Act, you are not required to use the Program before pursuing such remedies – although the Program is still available to you to resolve the dispute. When utilizing the Program, you will need to provide (a) the vehicle identification number of your vehicle, (b) the identity of your selling and servicing dealerships, (c) the mileage on your vehicle at relevant times, (d) the date and nature of any relevant repairs, (e) legible copies of repair orders and other relevant documents, (f) a summary of the unresolved issue and the requested action, and (g) your contact information. In most cases, the dispute resolution process under the Program will be completed within forty (40) days of your submission of your request and will consist of steps such as an initial eligibility determination, an opportunity for you and us to submit information in writing relating to your claim, an oral hearing, and a decision from the arbitrator. A decision will be binding on you only if you choose to accept it. You may submit a request to NCDS by telephone at their toll free number: (877)-276-8848 or in writing at P.O. Box 463196, Mt. Clemens, MI 48046. You may obtain additional information regarding the Program at www.ncdsusa.org. In the event that the NCDS does not exist or no longer handles disputes for us at the time that you seek to submit a request, you may contact our Customer Assistance Hotline at 1-800-301-6859 to obtain current information about our dispute resolution programs.

GENERAL LIMITATION OF WARRANTY: THIS LIMITED WARRANTY IS IN LIEU OF ALL OTHER EXPRESS WARRANTIES OR LIABILITIES. IN NO EVENT SHALL WE BE LIABLE FOR ANY CONSEQUENTIAL OR INCIDENTAL DAMAGES FOR BREACH OF THIS OR ANY OTHER WARRANTY. SOME STATES DO NOT ALLOW THE EXCLUSIONS OR LIMITATIONS OF INCIDENTAL OR CONSEQUENTIAL DAMAGES, SO THE ABOVE INFORMATION OR EXCLUSION MAY NOT APPLY. NO EXPRESS WARRANTY OF FITNESS OR MERCHANTABILITY IS GRANTED BY THIS LIMITED WARRANTY. THERE ARE NO WARRANTIES WHICH EXTEND BEYOND THOSE DESCRIBED IN THIS DOCUMENT. ANY IMPLIED WARRANTIES, INCLUDING THE IMPLIED WARRANTY OF MERCHANTABILITY OR FITNESS FOR A PARTICULAR PURPOSE, WHICH MAY BE APPLICABLE BY OPERATION OF LAW SHALL BE LIMITED TO THE PERIOD OF THIS WRITTEN LIMITED WARRANTY. SOME STATES DO NOT ALLOW LIMITATIONS ON HOW LONG AN IMPLIED WARRANTY LASTS, SO THE ABOVE LIMITATIONS MAY NOT APPLY. THIS LIMITED WARRANTY PROVIDES SPECIFIC LEGAL RIGHTS, AND THERE MAY BE OTHER RIGHTS WHICH VARY FROM STATE TO STATE. ANY ACTION FOR BREACH OF ANY WARRANTY HEREUNDER, INCLUDING ANY IMPLIED WARRANTY OF MERCHANTABILITY, MUST BE BROUGHT WITHIN A PERIOD NOT EXCEEDING 12 MONTHS AFTER EXPIRATION OF THIS LIMITED WARRANTY. THE REMEDIES SPECIFIED HEREIN AND THOSE SPECIFIED BY APPLICABLE LAW ARE THE ONLY REMEDIES AVAILABLE. WE ASSUME NO OTHER OBLIGATION OR RESPONSIBILITY WITH REGARD TO THE ACCESSORY. WE NEITHER ASSUME, NOR AUTHORIZE ANYONE TO ASSUME FOR US, ANY ADDITIONAL LIABILITY IN CONNECTION HEREWITH.

GENERAL: This limited warranty describes the complete and exclusive rights that result from the purchase of Accessories. No oral representations or statements may be relied upon. This limited warranty may not be amended or modified, and additional rights may not be granted, unless in a written statement signed by one of our officers. This limited warranty shall be governed by the laws of the state where the vehicle is purchased, excluding laws concerning conflicts of law. We may delegate the performance of our duties and obligations and assign our rights and benefits hereunder. For inquiries regarding this limited warranty, we can be contacted directly at **Customer Assistance Hotline at 1-800-301-6859**, or by mail to: **Southeast Toyota Distributors, LLC, Attention: Customer Loyalty Department, 100 Jim Moran Boulevard, Deerfield Beach, Florida 33442.**