

Advanced Brushed and Brushless Digital Motor Controllers



User Manual

V2.0, July 8, 2019

visit www.roboteq.com to download the latest revision of this manual

©Copyright 2019 Roboteq, Inc

Revision History

Date	Version	Changes
July 8, 2019	2.0	Separated CAN functionality ("CAN Networking Manual") Separated Microbasic ("Microbasic Scripting Manual") Separated Roborun+ Utility ("Roborun+ Utility User Manual") Miscellaneous updates in order to conform to firmware v2.0
August 28, 2017	1.8	Added AC Induction Sections Extended command set
October 15, 2016	1.7	Added Speed Position Mode Major Additions to Brushless Motor Section Added RoboCAN protocol Miscellaneous updates
May 10, 2012	1.2	Added CAN Networking Added Closed Loop Count Position mode, Closed Loop Torque mode Extended command set
January 8, 2011	1.2	Added Brushless Motor Connections and Operation
July 15, 2010	1.2	Extended command set Improved position mode
May 15, 2010	1.1	Added Scripting
January 1, 2010	1.0	Initial release

The information contained in this manual is believed to be accurate and reliable. However, it may contain errors that were not noticed at the time of publication. Users are expected to perform their own product validation and not rely solely on data contained in this manual.

	Revision History	2
	INTRODUCTION	17
	Refer to the Datasheet for Hardware-Specific Issues.....	17
	User Manual Structure and Use.....	17
	SECTION 1 Connecting Power and Motors to the Controller	17
	SECTION 2 Safety Recommendations	17
	SECTION 3 Connecting Sensors and Actuators to Input/Outputs	18
	SECTION 4 I/O Configuration and Operation.....	18
	SECTION 5 Magnetic Sensor	18
	SECTION 6 Command Modes	18
	SECTION 7 Motor Operating Features and Options.....	18
	SECTION 8 Brushless Motor Connections and Operation.....	18
	SECTION 9 AC Induction Motor Operation.....	18
	SECTION 10 Closed Loop Speed and Speed Position Modes	18
	SECTION 11 Closed Loop Relative and Tracking Position Modes.....	18
	SECTION 12 Closed Loop Count Position Mode	19
	SECTION 13 Closed Loop Torque Mode	19
	SECTION 14 Serial (RS232/RS485/USB/TCP) Operation	19
	SECTION 15 Commands Reference	19
SECTION 1	Connecting Power and Motors to the Controller.....	21
	Power Connections.....	21
	Controller Power	22
	Controller Powering Schemes.....	23
	Mandatory Connections.....	24
	Connection for Safe Operation with Discharged Batteries (note 1)	25
	Use precharge Resistor to prevent switch arcing (note 2)	25
	Protection against Damage due to Regeneration (notes 3 and 4)	25
	Connect Case to Earth if connecting AC equipment (note 5)	25
	Avoid Ground loops when connecting I/O devices (note 6)	25
	Connecting the Motors.....	26
	Single Channel Operation	27
	Power Fuses	27
	Wire Length Limits	27
	Electrical Noise Reduction Techniques.....	28
	Battery Current vs. Motor Current	28
	Measured and Calculated Currents.....	29
	Power Regeneration Considerations.....	30
	Using the Controller with a Power Supply	31
SECTION 2	Safety Recommendations.....	33
	Possible Failure Causes	33
	Motor Deactivation in Normal Operation	34
	Motor Deactivation in Case of Output Stage Hardware Failure.....	34
	Manual Emergency Power Disconnect.....	36

	Remote Emergency Power Disconnect.....	37
	Protection using Supervisory Microcomputer	37
	Self Protection against Power Stage Failure	38
	Safe Torque-Off (STO).....	39
	Safe Torque Off (STO) on Roboteq Controllers.....	40
	Activating STO	40
	Deactivating STO	40
	Constraints when using STO	40
	Sto Failure Messages	40
	Firmware implementation.....	41
	Installation – Maintenance	41
	STO Voltage source specification attention	42
	Compliance and Safety Metrics	42
	Technical Data	43
SECTION 3	Connecting Sensors and Actuators to Input/Outputs.....	45
	Controller Connections	45
	Controller’s Inputs and Outputs	46
	Connecting devices to Digital Outputs	47
	Connecting Resistive Loads to Outputs	47
	Connecting Inductive loads to Outputs.....	47
	Connecting Switches or Devices to Inputs shared with Outputs	48
	Connecting Switches or Devices to direct Digital Inputs.....	48
	Connecting a Voltage Source to Analog Inputs	49
	Reducing noise on Analog Inputs	50
	Connecting Potentiometers to Analog Inputs	50
	Connecting Potentiometers for Commands with Safety band guards.....	51
	Connecting Tachometer to Analog Inputs	52
	Connecting External Thermistor to Analog Inputs.....	53
	Using the Analog Inputs to Monitor External Voltages	54
	Connecting to RC Radios	55
	Connecting SSI Sensors	55
	SSI Sensors Overview	55
	Connecting the SSI Sensor.....	56
	Connecting Optical Encoders	56
	Optical Incremental Encoders Overview	56
	Recommended Encoder Types	57
	Connecting the Encoder	58
	Cable Length and Noise Considerations	58
	Motor - Encoder Polarity Matching	59
SECTION 4	I/O Configuration and Operation	61
	Basic Operation.....	61
	Input Selection	62
	Digital Inputs Configurations and Uses	62
	Analog Inputs Configurations and Use	63

	Analog Min/Max Detection.....	64
	Min, Max and Center adjustment.....	64
	Deadband Selection.....	65
	Command Correction.....	66
	Use of Analog Input.....	66
	Pulse Inputs Configurations and Uses.....	66
	Use of Pulse Input.....	67
	Digital Outputs Configurations and Triggers.....	68
	Encoder Configurations and Use	68
	SSI Configuration and Use.....	69
	Hall and other Rotor Sensor Inputs.....	70
	Sensor Min Max values	70
	Relative Speed	70
SECTION 5	Roboteq Products Connection and Operation	71
	Introduction to MGS1600 Magnetic Guide Sensor	71
	Introduction to FLW100 Flowsensor	72
	Introduction to BMS10X0 Battery Management System.....	72
	Available Interfaces	72
	MultiPWM interface.....	72
	Enabling MultiPWM Communication.....	73
	Accessing Sensor Information	74
	Connecting Multiple Similar Sensors	74
	Accessing Multiple Sensor Information Sequentially.....	75
	Accessing Multiple Sensor Information Simultaneously.....	75
SECTION 6	Command Modes.....	77
	Input Command Modes and Priorities	77
	USB vs Serial Communication Arbitration.....	79
	CAN Commands Arbitration.....	79
	Commands issued from MicroBasic scripts	79
	Operating the Controller in RC mode.....	80
	Input RC Channel Selection	81
	Input RC Channel Configuration.....	81
	Joystick Range Calibration	81
	Deadband Insertion.....	81
	Command Correction.....	81
	Reception Watchdog.....	81
	Using Sensors with PWM Outputs for Commands.....	82
	Operating the Controller In Analog Mode	82
	Input Analog Channel Selection	83
	Input Analog Channel Configuration	83
	Analog Range Calibration	83
	Using Digital Input for Inverting direction	83
	Safe Start in Analog Mode	83

	Protecting against Loss of Command Device	83
	Safety Switches	84
	Monitoring and Telemetry in RC or Analog Modes	84
	Using the Controller with a Spektrum Satellite Receiver	84
	Using the Controller in Serial (USB/RS232/RS485/TCP) Mode	84
SECTION 7	Motor Operating Features and Options.....	85
	Power Output Circuit Operation.....	85
	Global Power Configuration Parameters	86
	PWM Frequency	86
	Overvoltage Protection	86
	Undervoltage Protection	86
	Temperature-Based Protection.....	86
	Short Circuit Protection.....	87
	Mixed Mode Select.....	87
	Motor Channel Parameters.....	88
	User Selected Current Limit Settings	88
	Selectable Amps Threshold Triggering	89
	Programmable Acceleration & Deceleration	89
	Forward and Reverse Power Adjustment Gain	90
	Selecting the Motor Control Modes	90
	Open Loop Speed Control	90
	Closed Loop Speed Control	90
	Closed Loop Speed Position Control.....	91
	Closed Loop Position Relative Control	91
	Closed Loop Count Position.....	92
	Closed Loop Position Tracking.....	92
	Torque Mode.....	92
SECTION 8	Brushless Motor Connections and Operation.....	95
	Introduction to Brushless Motors	95
	Number of Poles	96
	Trapezoidal Switching.....	97
	Hall Sensor Wiring	98
	Hall Sensor Verification	99
	Hall Sensor Wiring Order	99
	Determining the Wiring Order Empirically	100
	Hall Sensor Alignment	101
	Sinusoidal Commutation.....	102
	Configuring the Controller for Sinusoidal Commutation	104
	Selecting and Configuring Supported Angle Sensors	106
	Preparation for Automatic Sensor Setup.....	111
	Running the Automatic Sensor Setup.....	114
	Field Oriented Control (FOC)	118
	Sensorless Trapezoidal Commutation	121

	Theory of Operation.....	121
	Sensorless Parameters.....	123
	Sensorless PWM Frequency.....	124
	Sensorless Auto-tuning.....	124
	Closed Loop Modes in Sensorless.....	125
	Operating Brushless Motors.....	125
	Stall Detection.....	125
	Speed Measurement using the angle feedback Sensors.....	126
	Distance Measurement using Hall, SSI or other Sensors.....	126
SECTION 9	AC Induction MotorOperation.....	127
	Introduction to AC Induction Motors.....	127
	Asynchronous Rotation and Slip.....	128
	Connecting the Motor.....	129
	Selecting and Connecting the Encoder.....	129
	Testing the Encoder.....	129
	Open Loop Variable Frequency Drive Operation.....	130
	Figuring the Motor's Volts per Hertz.....	130
	Maintaining Slip within Safe Range.....	131
	Closed Loop Speed Mode with Constant Slip Control.....	131
	Field Oriented Control (FOC) mode Operation.....	132
	Configuring FOC Torque Mode.....	133
	Configuring FOC Speed Mode.....	134
	Speed Limiting in FOC Torque Mode.....	135
SECTION 10	Closed Loop Speed and Speed-Position Modes.....	137
	Modes Description.....	137
	Closed Loop Speed Mode.....	137
	Closed Loop Speed Position Control.....	137
	Motor Sensors.....	138
	Tachometer or Encoder Mounting.....	138
	Tachometer wiring.....	138
	Brushless Hall Sensors as Speed Sensors.....	139
	Speed Sensor and Motor Polarity.....	139
	Controlling Speed in Closed Loop.....	140
	PID Description.....	141
	PID tuning in Closed Loop Speed Mode.....	142
	PID Tuning in Speed Position Mode.....	143
	Error Detection and Protection.....	144
SECTION 11	Closed Loop Relative and Tracking Position Modes.....	145
	Modes Description.....	145
	Position Relative Mode.....	145
	Position Tracking Mode.....	145
	Selecting the Position Modes.....	146
	Position Feedback Sensor Selection.....	146

	Sensor Mounting	146
	Feedback Sensor Range Setting	147
	Adding Safety Limit Switches	148
	Using Current Trigger as Protection	149
	Operating in Closed Loop Relative Position Mode.....	149
	Operating in Closed Loop Tracking Mode.....	151
	Position Mode Relative Control Loop Description.....	151
	PID tuning in Position Mode	152
	PID Tuning Differences between Position Relative and Position Tracking	153
	Loop Error Detection and Protection	153
SECTION 12	Closed Loop Count Position Mode	155
	Mode description.....	155
	Sensor Types and Mounting.....	156
	Encoder Home reference.....	156
	SSI Sensor Home reference	156
	Preparing and Switching to Closed Loop	156
	Count Position Commands	157
	Position Command Chaining.....	157
	Position Accuracy Considerations	158
	PID Tunings	159
	Loop Error Detection and Protection	159
SECTION 13	Closed Loop Torque Mode.....	161
	Torque Mode Description	161
	Torque Mode Selection, Configuration and Operation.....	162
	Torque Mode Tuning.....	162
	Configuring the Loop Error Detection	162
	Speed Limiting in Brushless controllers.....	163
	Torque Mode Limitations	163
	Torque Mode Using an External Amps Sensor	163
SECTION 14	Serial (RS232/RS485/USB/TCP) Operation	165
	Use and benefits of Serial Communication.....	165
	Serial Port Configuration	166
	Connector RS232 Pin Assignment.....	166
	Connector RS485 Pin Assignment.....	166
	Setting Different Bit Rates	166
	Cable configuration	167
	Extending the RS232 Cable	167
	Connecting to Arduino and other TTL Serial Microcomputers	168
	RS485 Configuration	169
	USB Configuration	170
	TCP Configuration	170
	Command Priorities	171
	Communication Arbitration	171

SECTION 15

CAN Commands	171
Script-generated Commands	171
Communication Protocol Description	171
Character Echo.....	172
Command Acknowledgment	172
Command Error	172
Watchdog time-out	172
Controller Present Check	172
Commands Reference	173
Commands Types.....	173
Runtime commands.....	173
Runtime queries.....	173
Maintenance commands	173
Configuration commands.....	174
Runtime Commands	174
AC - Set Acceleration	175
AX - Next Acceleration	176
B - Set User Boolean Variable	176
BND - Spectrum Bind.....	177
C - Set Encoder Counters	177
CB - Set Brushless Counter	178
CG - Set Motor Command via CAN	178
CS - CAN Send.....	179
CSS - Set SSI Sensor Counter	180
D0 - Reset Individual Digital Out bits	180
D1 - Set Individual Digital Out bits	181
DC - Set Deceleration	181
DS - Set all Digital Out bits	182
DX - Next Deceleration	183
EES - Save Configuration in EEPROM	183
EX - Emergency Stop.....	184
G - Go to Speed or to Relative Position.....	184
GIQ - Go to Torque Amps	185
GID - Go to Torque Amps	185
H - Load Home counter.....	186
MG - Emergency Stop Release.....	187
MS - Stop in all modes.....	187
P - Go to Absolute Desired Position.....	187
PR - Go to Relative Desired Position.....	188
PRX - Next Go to Relative Desired Position	189
PX - Next Go to Absolute Desired Position	189
R - MicroBasic Run	190
RC - Set Pulse Out.....	190

S - Set Motor Speed	191
STT - STO Self-Test	191
SX - Next Velocity.....	192
VAR - Set User Variable	192
DS402 Runtime Commands	193
CW – Control Word (DS402)	193
Profile Position Mode.....	194
Velocity Mode	194
PAC – Profile Acceleration (DS402)	195
PDC – Profile Deceleration (DS402).....	196
POS – Target Position (DS402)	196
PSP – Profile Velocity (DS402)	197
ROM – Modes of Operation (DS402).....	197
S – Target Velocity (DS402).....	197
SAC – Velocity Acceleration (DS402).....	198
SDC – Velocity Deceleration (DS402).....	199
SPL – Velocity Min/Max Amount (DS402)	199
TC – Target Torque (DS402)	200
TSL – Torque Slope (DS402).....	201
Runtime Queries.....	201
A - Read Motor Amps	203
AI - Read Analog Inputs	204
AIC - Read Analog Input after Conversion.....	204
ANG - Read Rotor Angle	205
ASI - Read Raw Sin/Cos sensor	205
B - Read User Boolean Variable.....	206
BA - Read Battery Amps	206
BCR - Read Brushless Count Relative.....	207
BMC - Read BMS State Of Charge in AmpHours.....	207
BMF - Read BMS status flags.....	208
BMS - Read BMS switch states	209
BS - Read BL Motor Speed in RPM.....	210
BSC - Read BMS State of Charge in percentage.....	210
BSR - Read BL Motor Speed as 1/1000 of Max RPM.....	211
C - Read Encoder Counter Absolute	212
CAN - Read Raw CAN frame	212
CB - Read Absolute Brushless Counter	213
CF - Read Raw CAN Received Frames Count.....	213
CIA - Read Converted Analog Command.....	214
CIP - Read Internal Pulse Command.....	214
CIS - Read Internal Serial Command.....	215
CL - Read RoboCAN Alive Nodes Map	215
CR - Read Encoder Count Relative	216

CSR - Read Relative SSI Sensor Counter.....	217
CSS - Read Absolute SSI Sensor Counter	217
D - Read Digital Inputs	218
DI - Read Individual Digital Inputs	218
DO - Read Digital Output Status	219
DPA - Read DC/Peak Amps	219
DR - Read Destination Reached.....	220
E - Read Closed Loop Error.....	220
F - Read Feedback.....	221
FC - Read FOC Angle Adjust.....	221
FLW - Read Flow Sensor Counter	222
FF - Read Fault Flags.....	223
FID - Read Firmware ID	223
FIN - Read Firmware ID (numerical).....	224
FM - Read Runtime Status Flag	224
FS - Read Status Flags	225
HS - Read Hall Sensor States	226
ICL - Is RoboCAN Node Alive.....	227
K - Read Spektrum Receiver	227
LK - Read Lock status	228
M - Read Motor Command Applied.....	228
MA - Read Field Oriented Control Motor Amps.....	229
MGD - Read Magsensor Track Detect.....	229
MGM - Read Magsensor Markers	230
MGS - Read Magsensor Status	231
MGT - Read Magsensor Track Position.....	231
MGY - Read Magsensor Gyroscope	232
MGX - Read MagSensor Tape Cross Detection	233
P - Read Motor Power Output Applied.....	233
PHA - Read Phase Amps	234
PI - Read Pulse Inputs.....	234
PIC - Read Pulse Input after Conversion	235
S - Read Encoder Motor Speed in RPM.....	236
SCC - Read Script Checksum.....	236
SNA - Read Sensor Angle	236
SR - Read Encoder Speed Relative	237
SS - Read SSI Sensor Motor Speed in RPM	237
SSR - Read SSI Sensor Speed Relative	238
STT - STO Self-Test Result	238
T - Read Temperature	239
TM - Read Time.....	240
TR - Read Position Relative Tracking.....	240
TRN - Read Control Unit type and Controller Model	241

UID - Read MCU Id	241
V - Read Volts	242
VAR - Read User Integer Variable	242
SL - Read Slip Frequency	243
DS402 Runtime Queries	243
AOM – Modes of Operation Display (DS402)	244
CW – Control Word (DS402)	244
F – Velocity/Position Actual Value (DS402)	245
PAC – Profile Acceleration (DS402)	245
PDC – Profile Deceleration (DS402)	246
POS – Target Position (DS402)	246
PSP – Profile Velocity (DS402)	247
RMP – VL Velocity Demand (DS402)	247
ROM – Modes of Operation (DS402)	248
S – Target Velocity (DS402)	248
SAC – Velocity Acceleration (DS402)	249
SDC – Velocity Deceleration (DS402)	249
SDM – Supported Drive Modes (DS402)	250
SPL – Velocity Min/Max Amount (DS402)	250
SW – Status Word (DS402)	251
TC – Target Torque (DS402)	253
TRQ – Target Torque (DS402)	253
TSL – Profile Acceleration (DS402)	254
VNM – Version Number (DS402)	254
Query History Commands	255
# - Send Next History Item / Stop Automatic Sending	255
# C - Clear Buffer History	256
# nn - Start Automatic Sending	256
# xx nn - Start automatic sending for specific stream	256
/?Q cc - Create data streams	257
//? - Dump the streams' prefixes and delimiters	258
Maintenance Commands	258
CLMOD – Motor/Sensor Setup	259
CLRST - Reset configuration to factory defaults	259
CLSAV - Save calibrations to Flash	259
DFU - Update Firmware via USB	260
EELD - Load Parameters from EEPROM	260
EELOG - Dump Flash Log Data	260
EERST - Reset Factory Defaults	261
EESAV - Save Configuration in EEPROM	261
ERASE - Erase Flash Log Data	261
LK - Lock Configuration Access	261
RESET - Reset Controller	262

SLD - Script Load	262
STIME - Set Time	262
UK - Unlock Configuration Access	262
Set/Read Configuration Commands	263
Setting Configurations	263
Reading Configurations.....	264
Configuration Read Protection	264
General Configuration and Safety	264
ACS - Analog Center Safety	265
AMS - Analog within Min & Max Safety	266
BEE - User Storage in Battery Backed RAM	266
BRUN - MicroBasic Auto Start	267
CLIN - Command Linearity.....	267
CPRI - Command Priorities	268
DFC - Default Command value	269
DMOD – Modbus Mode	270
ECHOF - Enable/Disable Serial Echo.....	270
EE - Store User Data in Flash.....	271
MDAL – Modbus Data Alignment.....	272
MNOD – Modbus Node ID	272
RSBR - Set RS232 bit rate	273
RS485 - Enable RS485.....	274
RWD - Serial Data Watchdog	274
SCRO - Select Print output port for scripting	275
SKCTR - Spektrum Center	275
SKDB - Spektrum Deadband.....	276
SKLIN - Spektrum Linearity.....	276
SKMAX - Spektrum Max.....	277
SKMIN - Spektrum Min.....	278
SKUSE - Assign Spektrum port to motor command	278
STO – STO Enable.....	279
TELS - Telemetry String.....	279
Analog, Digital, Pulse IO Configurations	280
ACTR - Set Analog Input Center (0) Level	281
ADB - Analog Deadband	281
AINA - Analog Input Use	282
ALIN - Analog Linearity	283
AMAX - Set Analog Input Max Range.....	283
AMAXA - Action at Analog Max	284
AMIN - Set Analog Input Min Range.....	285
AMINA - Action at Analog Min	285
AMOD - Enable and Set Analog Input Mode	286
APOL - Analog Input Polarity.....	287

DINA - Digital Input Action	288
DINL - Digital Input Active Level	288
DOA - Digital Output Action	289
DOL - Digital Outputs Active Level	290
PCTR - Pulse Center Range	290
PDB - Pulse Input Deadband.....	291
PINA - Pulse Input Use	291
PLIN - Pulse Linearity.....	292
PMAX - Pulse Max Range.....	293
PMAXA - Action on Pulse Max.....	293
PMIN - Pulse Min Range.....	294
PMINA - Action on Pulse Min	295
PMOD - Pulse Mode Select.....	295
PPOL - Pulse Input Polarity	296
Motor Configurations.....	297
ALIM - Amp Limit.....	298
ATGA - Amps Trigger Action	299
ATGD - Amps Trigger Delay	300
ATRIG - Amps Trigger Level.....	300
BKD - Brake activation delay in ms	301
BLFB - Encoder or Hall Sensor Feedback for closed loop.....	301
BLSTD - Stall Detection	302
CLERD - Close Loop Error Detection	303
EDEC - Fault Motor Deceleration Rate	304
EHL - Encoder High Count Limit.....	304
EHLA - Encoder High Limit Action	305
EHOME - Encoder Counter Load at Home Position.....	305
ELL - Encoder Low Count Limit.....	306
ELLA - Encoder Low Limit Action	307
EMOD - Encoder Usage	307
EPPR - Encoder PPR Value.....	308
ICAP - PID Integral Cap.....	309
KD - PID Differential Gain.....	309
KI - PID Integral Gain.....	310
KP - PID Proportional Gain	311
MAC - Motor Acceleration Rate	311
MDEC - Motor Deceleration Rate	312
MLX - Molex Input	313
MDIR - Motor Direction	313
MMOD - Operating Mode	314
MVEL - Default Position Velocity.....	314
MXMD - Separate or Mixed Mode Select.....	315
MXPF - Motor Max Power Forward	316

MXPR - Motor Max Power Reverse.....	316
MXRPM - Max RPM Value.....	317
MXTRN - Number of turns between limits.....	317
OVH - Overvoltage hysteresis.....	318
OVL - Overvoltage Cutoff Limit.....	319
OTL - Over Temperature Cutoff Limit.....	319
PWMF - PWM Frequency.....	320
SCPR - SSI Sensor CPR Value.....	320
SHL - SSI Sensor High Count Limit.....	321
SHLA - SSI Sensor High Limit Action.....	322
SHOME - SSI Sensor Counter Load at Home Position.....	322
SLL - SSI Sensor Low Count Limit.....	323
SLLA - SSI Sensor Low Limit Action.....	324
SMOD - SSI Sensor Usage.....	324
THLD - Short Circuit Detection Threshold.....	325
TNM - Motor Torque Constant.....	326
UVL - Undervoltage Limit.....	326
Brushless Specific Commands.....	327
BADJ - Brushless zero angle.....	328
BADV - Brushless timing angle adjust.....	328
BECC – BEMF Coupling Constant.....	329
BFBK - Brushless feedback sensor.....	329
BHL - Brushless Counter High Limit.....	330
BHLA - Brushless Counter High Limit Action.....	331
BHOME - Brushless Counter Load at Home Position.....	332
BLL - Brushless Counter Low Limit.....	332
BLLA - Brushless Counter Low Limit Action.....	333
BMOD - Brushless operating mode.....	334
BPOL - Number of Pole Pairs and Speed Polarity of Brushless Motor ..	335
BZPW - Brushless zero seek power level.....	335
HPO - Hall Sensor Position.....	336
HSM - Hall Sensor Map.....	337
KIF - FOC PID Integral Gain.....	337
KPF - FOC PID Proportional Gain.....	338
PSA - Phase Shift Angle.....	339
SPOL - Sin/Cos, Resolver or SSI sensor number of poles.....	339
SSF – Sensorless Start-Up Frequency.....	340
SVT – BEMF Integrator Limit.....	341
SWD - Swap Windings.....	341
TID - FOC Target Id.....	343
ZSMC - SinCos Calibration.....	343
AC Induction Specific Commands.....	344
VPH - AC Induction Volts per Hertz.....	344

ILM - Mutual Inductance.....	345
ILLR - Rotor Leakage Inductance.....	345
IRR - Rotor Resistance.....	346
MPW - Minimum Power	347
MXS - Optimal Slip Frequency	348
RFC - Rotor Flux Current.....	348
CAN Communication Commands.....	349
CAS - CANOpen Auto start	349
CBR - CAN Bit Rate	350
CEN - CAN Enable	350
CHB - CAN Heartbeat	351
CLSN - CAN Listening Node	351
CNOD - CAN Node Address	352
CSRT - MiniCAN SendRate	352
CTPS - CANOpen TPDO SendRate	353
CTT - CANOpen Transmission Type	353
FSA - DS402 PDS Finite State Automation Enable	354
TCP Communication Commands.....	354
DHCP - Enable DHCP	354
GWA - Gateway Address	355
IPA - IP Address	356
IPP - IP Port.....	357
PDNS - Primary DNS.....	357
SBM - Subnet Mask.....	358
SDNS - Primary DNS.....	359
WMOD - TCP Mode	360

Introduction

Refer to the Datasheet for Hardware-Specific Issues

This manual is the companion to your controller's datasheet. All information that is specific to a particular controller model is found in the datasheet. These include:

- Number and types of I/O
- Connectors pin-out
- Wiring diagrams
- Maximum voltage and operating voltage
- Thermal and environmental specifications
- Mechanical drawings and characteristics
- Available storage for scripting
- Battery or/and Motor Amps sensing
- Storage size of user variables to Flash or Battery-backed RAM

User Manual Structure and Use

The user manual discusses issues that are common to all controllers inside a given product family. Except for a few exceptions, the information contained in the manual does not repeat the data that is provided in the datasheets.

For CAN please refer to "CAN Networking Manual". For Modbus please refer to "Modbus Manual". For Microbasic scripting please refer to "Microbasic Scripting Manual". For Roborun+ Utility please refer to "Roborun+ Utility User Manual". This manual is divided into 15 sections organized as follows:

SECTION 1 Connecting Power and Motors to the Controller

This section describes the power connections to the battery and motors, the mandatory vs. optional connections. Instructions and recommendations are provided for safe operation under all conditions.

SECTION 2 Safety Recommendations

This section lists the possible motor failure causes and provides examples of prevention methods and possible ways to regain control over motor if such failures occur.

SECTION 3 Connecting Sensors and Actuators to Input/Outputs

This section describes all the types of inputs that are available on all controller models and describes how to attach sensors and actuators to them. This section also describes the connection and operation of optical encoders.

SECTION 4 I/O Configuration and Operation

This section details the possible use of each type of Digital, Analog, Pulse or Encoder inputs, and the Digital Outputs available on the controller. It describes in detail the software configurable options available for each I/O type.

SECTION 5 Magnetic Sensor

This section discusses how to interface one or more Roboteq's products (MGS1600, BMS1040, etc.) to the motor controller.

SECTION 6 Command Modes

The controller can be operated using serial, analog or pulse commands. This section describes each of these modes and how the controller can switch from one command input to another. Detailed descriptions are provided for the RC pulse and Analog command modes and all their configurable options.

SECTION 7 Motor Operating Features and Options

This section reviews all the configurable options available to the motor driver section. It covers global parameters such as PWM frequency, overvoltage, or temperature-based protection, as well as motor channel-specific configurations. These include amps limiting, acceleration/deceleration settings, or operating modes.

SECTION 8 Brushless Motor Connections and Operation

This section addresses the installation and operating issues specific to brushless motors. It is applicable only to brushless motor controller models.

SECTION 9 AC Induction Motor Operation

This section discusses the controller's operating features and options when using three-phase AC Induction motors.

SECTION 10 Closed Loop Speed and Speed Position Modes

This section focuses on the closed loop speed mode with feedback using analog speed sensors or encoders. Information is provided on how to setup a closed loop speed control system, tune the PID control loop, and operate the controller.

SECTION 11 Closed Loop Relative and Tracking Position Modes

This section describes how to configure and operate the controller in position mode using analog, pulse, or encoder feedback. In position mode, the motor can be made to smoothly go from one position to the next. Information is provided on how to setup a closed loop position system, tune the PID control loop, and operate the controller.

SECTION 12 Closed Loop Count Position Mode

This section describes how to configure and operate the controller in Closed Loop Count Position mode. Position command chaining is provided to ensure seamless motor motion.

SECTION 13 Closed Loop Torque Mode

This section describes how to select, configure and operate the controller in Closed Loop Torque mode.

SECTION 14 Serial (RS232/RS485/USB/TCP) Operation

This section describes how to communicate to the controller via the RS232, RS485, USB or TCP interface.

SECTION 15 Commands Reference

This section lists and describes in detail all configuration parameters, runtime commands, operating queries, and maintenance commands available in the controller.

SECTION 1

Connecting Power and Motors to the Controller

This section describes the controller's connections to power sources and motors.

This section does not show connector pin-outs or wiring diagram. Refer to the datasheet for these.

Important Warning

The controller is a high power electronics device. Serious damage, including fire, may occur to the unit, motor, wiring, and batteries as a result of its misuse. Please follow the instructions in this section very carefully. Any problem due to wiring errors may have very serious consequences and will not be covered by the product's warranty.

Power Connections

Power connections are described in the controller model's datasheet. Depending on the model type, power connection is done via wires, fast-on tabs, screw terminals or copper bars coming out of the controller.

Controllers with wires as power connections have Ground (black), VMot (red) power cables and a Power Control wire (yellow). The power cables are located at the back end of the controller. The various power cables are identified by their position, wire thickness and color: red is positive (+), black is negative or ground (-).

Controllers with tabs, screw terminals or copper bars have their connector identified in print on the controller.

Controller Power

The controller uses a flexible power supply scheme that is best described in Figure 1-1. In this diagram, it can be seen that the power for the Controller's internal microcomputer is separate from this of the motor drivers. The microcomputer circuit is connected to a DC/DC converter which takes power from either the Power Control input or the VMot input. A diode circuit that is included in most controller models, is designed to automatically select one power source over the other and lets through the source that has the highest voltage.

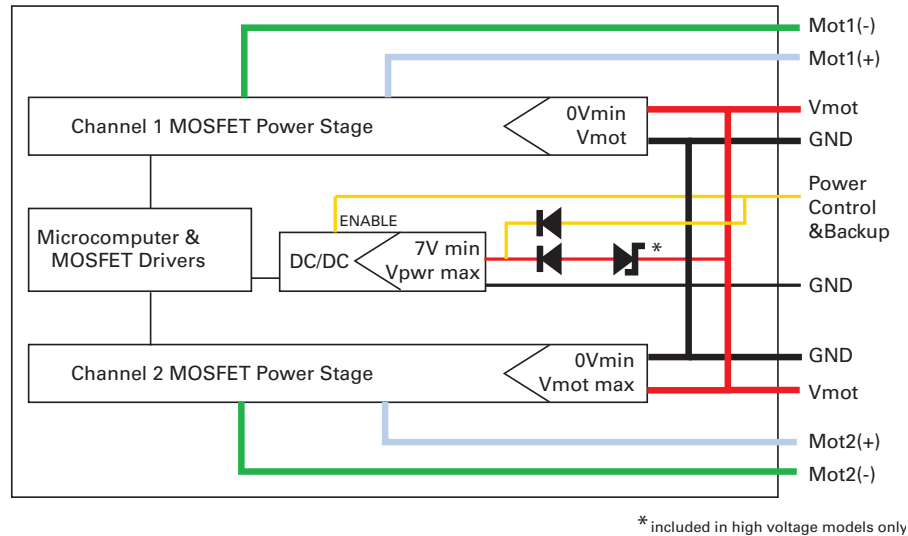

FIGURE 1-1. Representations of the controller's Internal Power Circuits

When powered via the Power Control input only, the controller will turn On, but motors will not be able to turn until power is also present on the VMot wires or Tab.

The Power Control input also serves as the Enable signal for the DC/DC converter. When floating or pulled to above 1V, the DC/DC converter is active and supplies the controller's microcomputer and drivers, thus turning it On. When the Power Control input is pulled to Ground, the DC/DC converter is stopped and the controller is turned Off.

The Power Control input **MUST** be connected to Ground to turn the Controller Off. For turning the controller On, even though the Power Control may be left floating, whenever possible pull it to a 12V or higher voltage to keep the controller logic solidly On. You may use a separate battery to keep the controller alive as the main Motor battery discharges.

On the high voltage controller that is rated above 60V, a zener diode is inserted between the VMot supply and the DC/DC converter. This causes a voltage drop that keeps the voltage at the converter's input within its maximum operating range. However, this diode also

increases by around 20V the low voltage threshold at which the controller will start operating when powered from VMot alone.

The table below shows the state of the controller depending on the voltage applied to Power Control and VMot.

TABLE 1-1. Controller Status depending on Power Control and VMot

Power Control input is connected to	And Main Battery Voltage is	Action
Ground	Any Voltage	Controller is Off. Required Off Configuration.
Floating	0V	Controller is Off. Not Recommended Off Configuration.
Floating	Above VMotMin (1)	Controller is On. Power Stage is Active (2)
7V to max PwrCtl (3) Volts	Any Voltage	Controller is On. Power Stage is Active (2)
Note 1: VMotMin = 7V on all controller rated up to 60V. VMotMin = 28V on all controllers rated above 60V. See product datasheet Note 2: Power Stage is active but turned off when overvoltage or undervoltage condition. Note 3: 35V max on 30V controllers. 60V max on all products rated above 30V		

Note: All ground terminals (-) are connected to each other inside the controller. On dual channel controllers, the two VMot main battery wires are also connected to each other internally. However, you must never assume that connecting one wire of a given battery potential will eliminate the need to connect the other. When pre-charging the controller's capacitors, the Power Control input must be grounded. See the note on capacitor pre-charging on page 25. "Capacitor precharging"

Controller Powering Schemes

Roboteq controllers operate in an environment where high currents may circulate in unexpected manners under certain condition. Please follow these instructions. Roboteq reserves the right to void product warranty if analysis determines that damage is due to improper controller power connection.

The example diagram on Figure 1-2 on page 24 shows how to wire the controller and how to turn power On and Off. All Roboteq models use a similar power circuit. See the controller datasheet for the exact wiring diagram for your controller model.

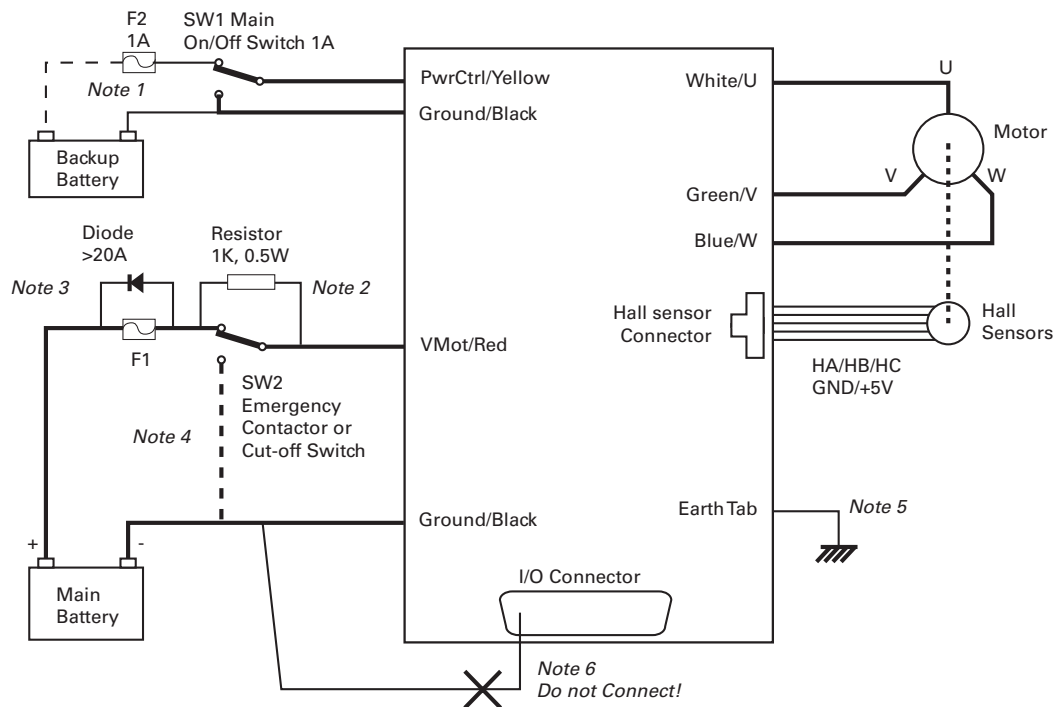

FIGURE 1-2. Brushless DC Controller power wiring diagram

Mandatory Connections

It is imperative that the controller is connected as shown in the wiring diagram provided in the datasheet in order to ensure safe and trouble-free operation. All connections shown as thick black lines are mandatory.

- Connect the thick black wire(s) or the ground terminal to the minus (-) terminal of the battery that will be used to power the motors. Connect the thick red wire(s) or VMot terminal to the plus (+) terminal of the battery. The motor battery may be of 12V up to the maximum voltage specified in the controller model datasheet.
- The controller must be powered On/Off using switch SW1 on the Power Control wire/terminal. Grounding this line powers Off the controller. Floating or pulling this line to a voltage will power On the controller. (SW1 is a common SPDT 1 Amp or more switch).
- Use a suitable high-current fuse F1 as a safety measure to prevent damage to the wiring in case of a major controller malfunction. (Littlefuse ATO or MAXI series).
- The battery must be connected in permanence to the controller's Red wire(s) or VMot terminal via a high-power emergency switch SW2 as an additional safety measure. Partially discharged batteries may not blow the fuse, while still having enough power left to cause a fire. Leave the switch SW2 closed at all times and open only in case of an emergency. Use the main On/Off switch SW1 for normal operation. This will prolong the life of SW2, which is subject to arcing when opening under high current with the consequent danger of contact welding.
- If installing in an electric vehicle equipped with a Key Switch where SW2 is a contactor, and the key switch energizes the SW2 coil, then implement SW1 as a relay. Connect the Key Switch to both coils of SW1 and SW2 so cutting off the power to the vehicle by the key switch and SW2 will set the main switch SW1 in the OFF position as well.

Connection for Safe Operation with Discharged Batteries (note 1)

The controller will stop functioning when the main battery voltage drops below 7V. To ensure motor operation with weak or discharged batteries, connect a second battery to the Power Control wire/terminal via the SW1 switch. This battery will only power the controller's internal logic. The motors will continue to be powered by the main battery while the main battery voltage is higher than the secondary battery voltage.

Use precharge Resistor to prevent switch arcing (note 2)

Insert a 1K, 0.5W resistor across the SW2 Emergency Switch. This will cause the controller's internal capacitors to slowly charge and maintain the full battery voltage by the time the SW2 switch is turned on and thus eliminate damaging arcing to take place inside the switch. Make sure that the controller is turned Off with the Power Control wire grounded while the SW2 switch is off. The controller's capacitors will not charge if the Power Control wire is left floating and arcing will then occur when the Emergency switch is turned on.

Protection against Damage due to Regeneration (notes 3 and 4)

The voltage generated by motors rotating while not powered by the controller can cause serious damage even if the controller is Off or disconnected. This protection is highly recommended in any application where high motion inertia exists or when motors can be made to rotate by towing or pushing.

- Use the main SW1 switch on the Power Control wire/terminal to turn Off and keep Off the controller.
- Insert a high-current diode (Digikey P/N 10A01CTND) to ensure a return path to the battery in case the fuse is blown. Smaller diodes are acceptable as long as their single pulse current rating is > 20 Amp.
- Optionally use a Single Pole, Dual Throw switch for SW2 to ground the controller power input when OFF. If a SPDT switch cannot be used, then consider extending the diode across the fuse and the switch SW2.

Connect Case to Earth if connecting AC equipment (note 5)

If building a system which uses rechargeable batteries, it must be assumed that periodically a user will connect an AC battery charger to the system. Being connected to the AC main, the charger may accidentally bring AC high voltage to the system's chassis and to the controller's enclosure. A similar danger exists when the controller is powered via a power supply connected to the mains.

Some controller models in metallic enclosures are supplied with an Earth tab, which permits earthing the metal case. Connect this tab to a wire connected to the Earth while the charger is plugged in the AC main, or if the controller is powered by an AC power supply or is being repaired using any other AC equipment (PC, Voltmeter etc.)

Avoid Ground loops when connecting I/O devices (note 6)

When connecting a PC, encoder, switch or actuators on the I/O connector, be very careful that you do not create a path from the ground pins on the I/O connector and the battery minus terminal. Should the controller's main Ground wires (thick black) or terminals be disconnected while the VMot wires (thick red) or terminals are connected, the high current would flow from the ground pins, potentially causing serious damage to the controller and/or your external devices.

- Do not connect a wire between the I/O connector ground pins and the battery minus terminal. Look for hidden connection and eliminate them.
- Have a very firm and secure connection of the controller ground wire and the battery minus terminal.
- Do not use connectors or switches on the power ground cables.

Important Warning

Do not rely on cutting power to the controller for it to turn Off if the Power Control is left floating. If motors are spinning because the robot is pushed or because of inertia, they will act as generators and will turn the controller On, possibly in an unsafe state. ALWAYS ground the Power Control wire terminal to turn the controller Off and keep it Off.

Important Warning

Unless you can ensure a steady voltage that is higher than 7V (28V in controllers rated above 60V) in all conditions, it is recommended that the battery used to power the controller's electronics be separate from the one used to power the motors. This is because it is very likely that the motor batteries will be subject to very large current loads which may cause the voltage to eventually dip below 7V as the batteries' charge drops. The separate backup power supply should be connected to the Power Control input.

Connecting the Motors

Refer to the datasheet for information on how to wire the motor(s) to a particular motor controller model.

After connecting the motors, apply a minimal amount of power using the Roborun PC utility with the controller configured in **Open Loop speed mode**. Verify that the motor spins in the desired direction. Immediately stop and swap the motor wires if not.

In Closed Loop Speed or Position mode, beware that the motor polarity must match this of the feedback. If it does not, the motors will runaway with no possibility to stop other than switching Off the power. The polarity of the Motor or of the feedback device may need to be changed.

Important Warning

Make sure that your motors have their wires isolated from the motor casing. Some motors, particularly automotive parts, use only one wire, with the other connected to the motor's frame. If you are using this type of motor, make sure that it is mounted on isolators and that its casing will not cause a short circuit with other motors and circuits which may also be inadvertently connected to the same metal chassis.

Single Channel Operation

Dual channel Brushed DC controllers may be ordered with the -S (Single Channel) suffix.

The two channel outputs must be paralleled as shown in the datasheet so that they can drive a single load with twice the power. To perform in this manner, the controller's Power Transistors that are switching in each channel must be perfectly synchronized. Without this synchronization, the current will flow from one channel to the other and cause the destruction of the controller.

The single channel version of the controller incorporates a hardware setting inside the controller which ensures that both channels switch in a synchronized manner and respond to commands sent to channel 1.

Important Warning

Before pairing the outputs, attach the motor to one channel and then the other. Verify that the motor responds the same way to command changes.

Power Fuses

For low Amperage applications (below 30A per motor), it is recommended that a fuse be inserted in series with the main battery circuit as shown in Figure 1-2 on page 24.

The fuse will be shared by the two output stages and therefore must be placed before the Y connection to the two power wires. Fuse rating should be the sum of the expected current on both channels. Note that automotive fuses above 40A are generally slow, will be of limited effectiveness in protecting the controller and may be omitted in the high current application. The fuse will mostly protect the wiring and battery against after the controller has failed.

Important Warning

Fuses are typically slow to blow and will thus allow temporary excess current to flow through them for a time (the higher the excess current, the faster the fuse will blow). This characteristic is desirable in most cases, as it will allow motors to draw surges during acceleration and braking. However, it also means that the fuse may not be able to protect the controller.

Wire Length Limits

The controller regulates the output power by switching the power to the motors On and Off at high frequencies. At such frequencies, the wires' inductance produces undesirable effects such as parasitic RF emissions, ringing, and overvoltage peaks. The controller has built-in capacitors and voltage limiters that will reduce these effects. However, should the wire inductance be increased, for example by extended wire length, these effects will be amplified beyond the controller's capability to correct them. This is particularly the case for the main battery power wires.

Important Warning

Avoid long connection between the controller and power source, as the added inductance may cause damage to the controller when operating at high currents. Try extending the motor wires instead since the added inductance is not harmful on this side of the controller.

If the controller must be located at a long distance from the power source, the effects of the wire inductance may be reduced by using one or more of the following techniques:

- Twisting the power and ground wires over the full length of the wires
- Use the vehicle's metallic chassis for ground and run the positive wire along the surface
- Add a capacitor (10,000uF or higher) near the controller

Electrical Noise Reduction Techniques

As discussed in the above section, the controller uses fast switching technology to control the amount of power applied to the motors. While the controller incorporates several circuits to keep electrical noise to a minimum, additional techniques can be used to keep the noise low when installing the controller in an application. Below is a list of techniques you can try to keep noise emission low:

- Keep wires as short as possible
- Loop wires through ferrite cores
- Add snubber RC circuit at motor terminals
- Keep controller, wires, and battery enclosed in a metallic body

Battery Current vs. Motor Current

The controller limits the current that flows through the motors and not the battery current. Current that flows through the motor is typically higher than the battery current. This counter-intuitive phenomenon is due to the "flyback" current in the motor's inductance. In some cases, the motor current can be extremely high, causing heat and potentially damage while battery current appears low or reasonable.

The motor's power is controlled by varying the On/Off duty cycle of the battery voltage 16,000 times per second to the motor from 0% (motor off) to 100 (motor on). Because of the inductive flyback effect, during the Off time current continues to flow at nearly the same peak - and not the average - level as during the On time. At low PWM ratios, the peak current - and therefore motor current - can be very high as shown in Figure 1-4, on next page.

The relation between Battery Current and Motor current is given in the formula below:

$$\text{Motor Current} = \text{Battery Current} / \text{PWM ratio}$$

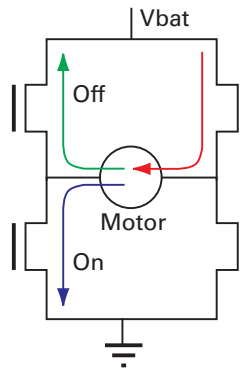

FIGURE 1-3. Current flow during operation

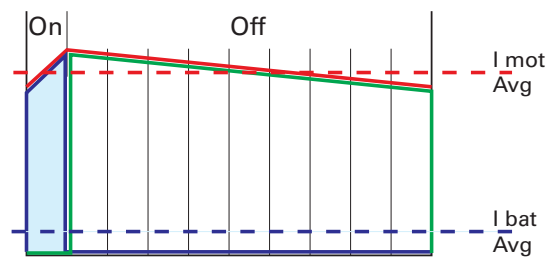

FIGURE 1-4. Instant and average current waveforms

The relation between Battery Current and Motor current is given in the formula below:

$$\text{Motor Current} = \text{Battery Current} / \text{PWM Ratio}$$

Example: If the controller reports 10A of battery current while at 10% PWM, the current in the motor is $10 / 0.1 = 100\text{A}$.

Measured and Calculated Currents

Some Roboteq Brushed DC motor controllers, have current sensors for measuring the battery current and estimate the motor current. At 20% PWM and above, the motor current is computed using the formula above. Below 20%, and approaching 0%, this method causes unstable and imprecise readings. At these levels the formula used is

$$\text{Motor Current} = \text{Battery Current} / 0.20$$

This approximation creates a more stable value but one that is increasingly inaccurate as the PWM approaches 0%. This approximation produces usable value nevertheless.

Roboteq's Brushless motor controllers use sensors on the motor outputs or/and on the battery ground terminal. Controllers using sensors on the battery terminal outputs suffer the same limitation at low PWM as discussed above.

Controllers with sensors on the motor terminals provide accurate motor current sensing in all conditions, and provide a good estimate battery current value. Some controller models have sensors on the motor and on the battery terminals, and provide the most accurate current sensing as all are actually measured values.

Whether sensors are on the motor or/and battery terminals can be found in the product's datasheet

Important Warning

Do not connect a motor that is rated at a higher current than the controller.

Power Regeneration Considerations

When a motor is spinning faster than it would normally at the applied voltage, such as when moving downhill or decelerating, the motor acts as a generator. In such cases, the current will flow in the opposite direction, back to the power source.

It is therefore essential that the controller is connected to rechargeable batteries. If a power supply is used instead, the current will attempt to flow back in the power supply during regeneration, potentially damaging it and/or the controller.

Regeneration can also cause potential problems if the battery is disconnected while the motors are still spinning. In such a case, the energy generated by the motor will keep the controller On, and depending on the command level applied at that time, the regenerated current will attempt to flow back to the battery. Since none is present, the voltage will rise to potentially unsafe levels. The controller includes an overvoltage protection circuit to prevent damage to the output transistors (see "Using the Controller with a Power Supply" below). However, if there is a possibility that the motor could be made to spin and generate a voltage higher than 40V, a path to the battery must be provided, even after a fuse is blown. This can be accomplished by inserting a diode across the fuse as shown in Figure 1-2 on page 24.

Please download the Application Note "Understanding Regeneration" from the www.roboteq.com for an in-depth discussion of this complex but important topic.

Important Warning

Use the controller only with a rechargeable battery as supply to the Motor Power wires (thick black and red wires). If a transformer or power supply is used, damage to the controller and/or power supply may occur during regeneration. See "Using the Controller with a Power Supply" below for details.

Important Warning

Avoid switching Off or cutting open the main power cables while the motors are spinning. Damage to the controller may occur. Always ground the Power Control wire to turn the controller Off.

Using the Controller with a Power Supply

Using a transformer or a switching power supply is possible but requires special care, as the current will want to flow back from the motors to the power supply during regeneration. As discussed in “Power Regeneration Considerations” above, if the supply is not able to absorb and dissipate regenerated current, the voltage will increase until the over-voltage protection circuit cuts off the motors. While this process should not be harmful to the controller, it may be to the power supply, unless one or more of the protective steps below is taken:

- Use a power supply that will not suffer damage in case a voltage is applied at its output that is higher than its own output voltage. This information is seldom published in commercial power supplies, so it is not always possible to obtain positive reassurance that the supply will survive such a condition.
- Avoid deceleration that is quicker than the natural deceleration due to the friction in the motor assembly (motor, gears, load). Any deceleration that would be quicker than natural friction means that braking energy will need to be taken out of the system, causing a reverse current flow and voltage rise.
- Place a battery in parallel with the power supply output. This will provide a reservoir into which regeneration current can flow. It will also be very helpful for delivering high current surges during motor acceleration, making it possible to use a lower current power supply. Batteries mounted in this way should be connected for the first time only while fully charged and should not be allowed to discharge. The power supply will be required to output unsafe amounts of current if connected directly to a discharged battery. Consider using a decoupling diode on the power supply's output to prevent battery or regeneration current to flow back into the power supply.
- Place a resistive load in parallel with the power supply, with a circuit to enable that load during regeneration. This solution is more complex but will provide a safe path for the braking energy into a load designed to dissipate it. The diagram below shows an example of such a circuit. The controller must be configured so that its digital output is activated when an overvoltage condition is detected. The MOSFET and brake resistor value must be sized according to the expected regeneration current that must be absorbed.

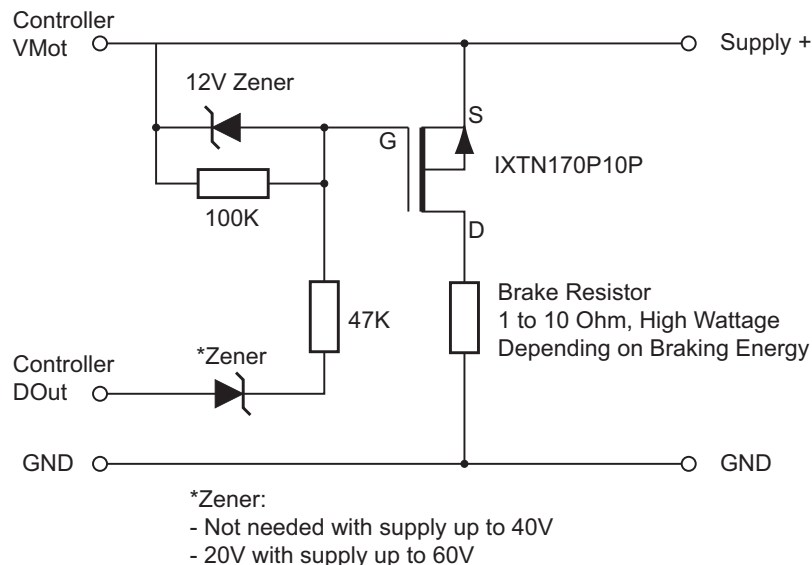

FIGURE 1-5. regen brake resistor

Note: The schematic above is provided for reference only. It may not work in all conditions.

SECTION 2

Safety

Recommendations

In many applications, Roboteq controllers drive high power motors that move parts and equipment at high speed and/or with very high force. In case of malfunction, potentially enormous forces can be applied at the wrong time and/or wrong place causing serious damage to property and/or harm to a person. While Roboteq controllers operate very reliably, and failures are rare, a failure is possible as with any other electronic equipment. If there is any danger that a loss of motor control can cause damage or injury, you must plan on that possibility and implement methods for stopping the motor **independently of the controller operation**.

Below is a list of failure categories, their effect and possible ways to regain control, or minimize the consequences. The list of possible failures is not exhaustive and the suggested prevention methods are provided as examples for information only.

Important Safety Disclaimer

Dangerous uncontrolled motor runaway condition can occur for a number of reasons, including, but not limited to command or feedback wiring failure, configuration error, faulty firmware, errors in user MicroBasic script or in the user program, or controller hardware failure. The user must assume that such failures can occur and must take all measures necessary to make his/her system safe in all conditions. The information contained in this manual, and in this section in particular, is provided for information only. Roboteq will not be liable in case of damage or injury as a result of product misuse or failure.

Possible Failure Causes

The dangerous unintended motor operation could occur for a number of reasons, including, but not limited to:

- Failure in Command device
- Feedback sensors malfunction
- Wiring errors or failure
- Controller configuration error
- Faulty firmware

- Errors or oversights in user MicroBasic scripts
- Controller hardware failure

Motor Deactivation in Normal Operation

In normal operation, the controller is always able to turn off the motor if it detects faults or if instructed to do so from an external command.

In case of wiring problem, sensor malfunction, firmware failure or error in user Microbasic scripts, the controller may be in a situation where the motors are turned on and kept on as long as the controller is powered. A number of features discussed throughout this manual are available to stop motor operation in case of an abnormal situation. These include:

- Watchdog on missing incoming serial/USB commands
- Loss detection of Radio Pulse
- Analog command outside the valid range
- Limit switches
- Stall detection
- Close Loop error detection
- Other ...

Additional features can easily be added using MicroBasic scripting.

Ultimately, the controller can be simply turned off by grounding the Power Control pin. Assuming there is no hardware damage in the power stage, the controller output will be off (i.e. motor wires floating) when the controller is off.

Important Warning:

While cutting the power to the motors is generally the best thing to do in case of major failure, it may not necessarily result in a safe situation.

Motor Deactivation in Case of Output Stage Hardware Failure

On brushed DC motor controllers, the power stage for each motor is composed of 4 MOSFETs (semiconductor switches). In some cases of MOSFET failures, it is possible that one or both motors will remain permanently powered with no way to stop them either via software or by turning the controller off.

On brushless motor controllers, shorted MOSFETs will not cause the motor to turn on its own. Nevertheless, it is still advised to follow the recommendations included in this section.

The figures below show all the possible combinations of shorted MOSFETs switches in a brushed DC motor controller.

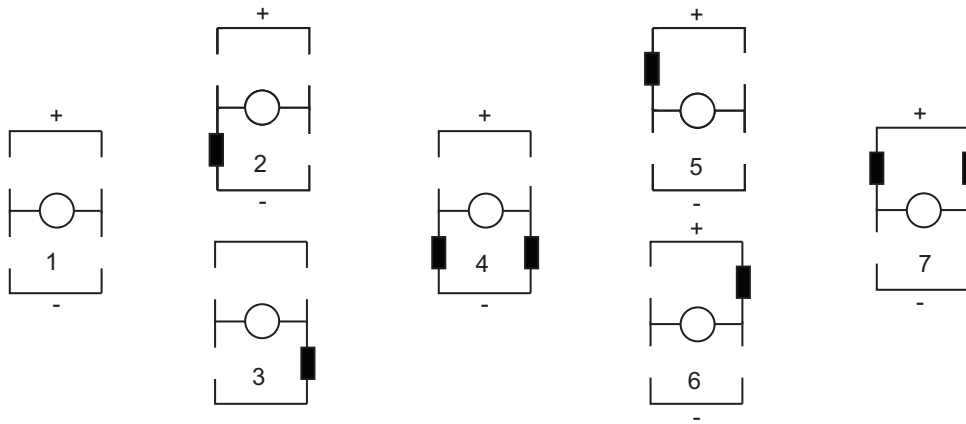

FIGURE 2-1. MOSFET Failures resulting in no motor activation

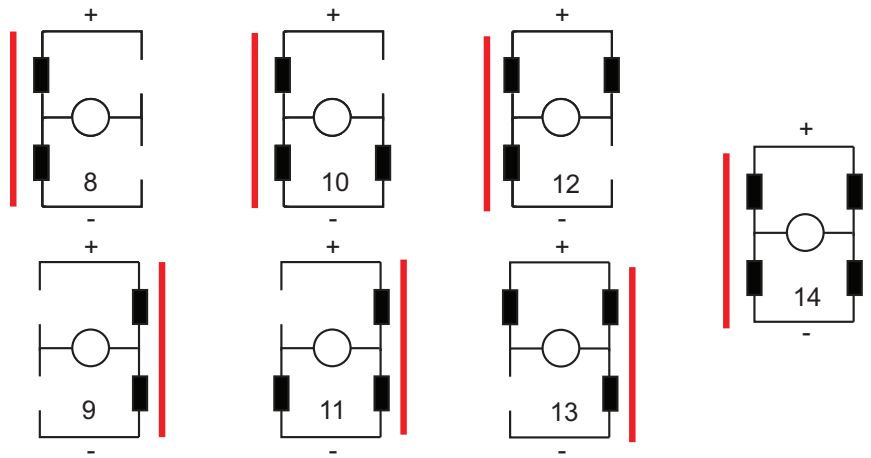

FIGURE 2-2. MOSFET Failures resulting in battery short circuit and no motor activation

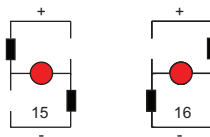

FIGURE 2-3. MOSFET Failure resulting in motor activation

Two failure conditions (15 and 16) will result in the motor spinning out of control regardless of whether the controller is on or off. While these failure conditions are rare, users must take them into account and provide means to cut all power to the controller's power stage.

Manual Emergency Power Disconnect

In systems where the operator is within physical reach of the controller, the simplest safety device is the emergency disconnect switch that is shown in the wiring diagram inside all controller datasheets, and in the example diagram below.

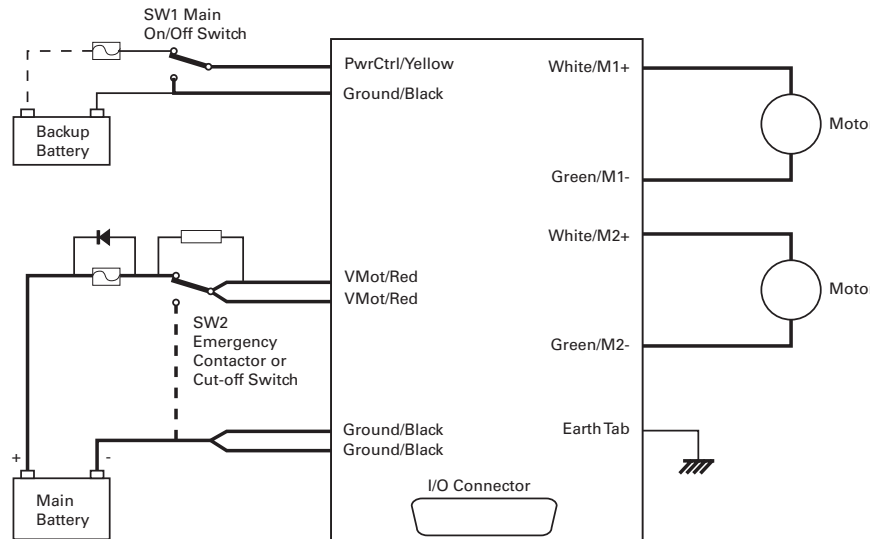

FIGURE 2-4. Example powering diagram (Brushed DC motor Controller)

The switch must be placed visibly and be easy to operate. Prefer “mushroom” emergency stop push buttons. Make sure that the switches are rated at the maximum current that can be expected to flow through all motors at the same time.



FIGURE 2-5. “Mushroom” type Emergency Disconnect Switch

Remote Emergency Power Disconnect

In remote controlled systems, the emergency switch must be replaced by a high power contactor relay as shown in Figure 2-6. The relay must be normally open and be activated using an RC switch on a separate radio channel. The receiver should preferably be powered directly from the system's battery. If powered from the controller's 5V output, keep in mind that in case of a total failure of the controller, the 5V output may or may not be interrupted.

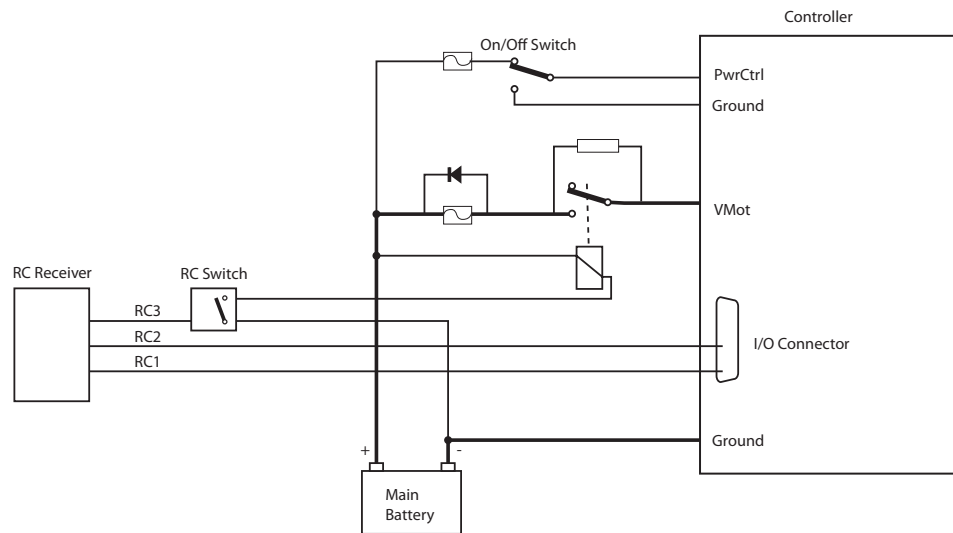

FIGURE 2-6 Example of remotely operated safety disconnect

The receiver must operate in such a way that the contactor relay will be off if the transmitter is off or out of range.

The transmitter should have a visible and easy to reach an emergency switch for the operator. That switch will be used to deactivate the relay remotely. It could also be used to shutdown entirely the transmitter, assuming it is determined for certain that this will deactivate the relay at the controller.

Protection using Supervisory Microcomputer

In applications where the controller is commanded by a PC, a microcomputer or a PLC, that supervisory system could be used to verify that the controller is still responding and cut the power to the controller's power stage in case a malfunction is detected. The supervisory system would only require a digital output or other means to activate/deactivate the contactor relay as shown in the figure below.

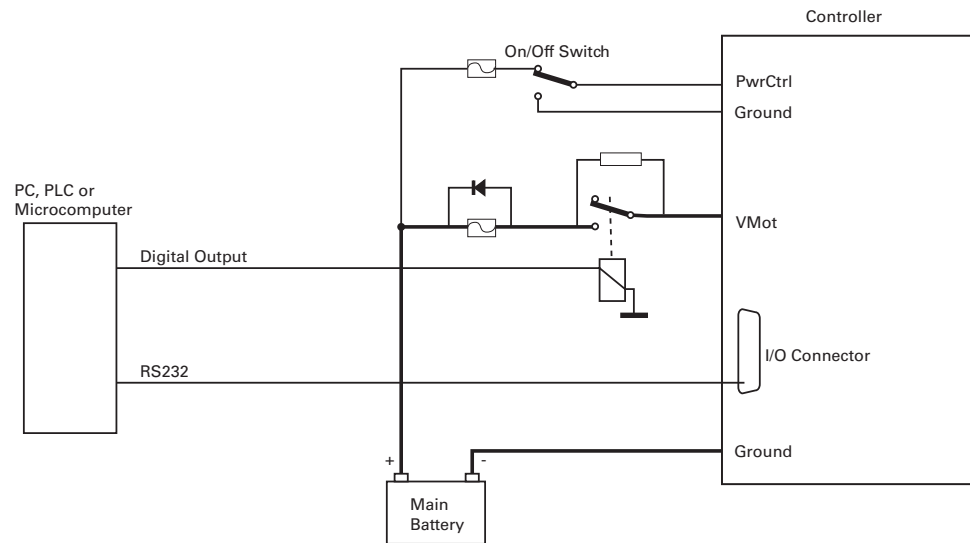

FIGURE 2-7. Example of safety disconnect via supervisory system

Self Protection against Power Stage Failure

If the controller processor is still operational, it can self detect several, although not all, situations where a motor is running while the power stage is off. The figure below shows a protection circuit using an external contactor relay.

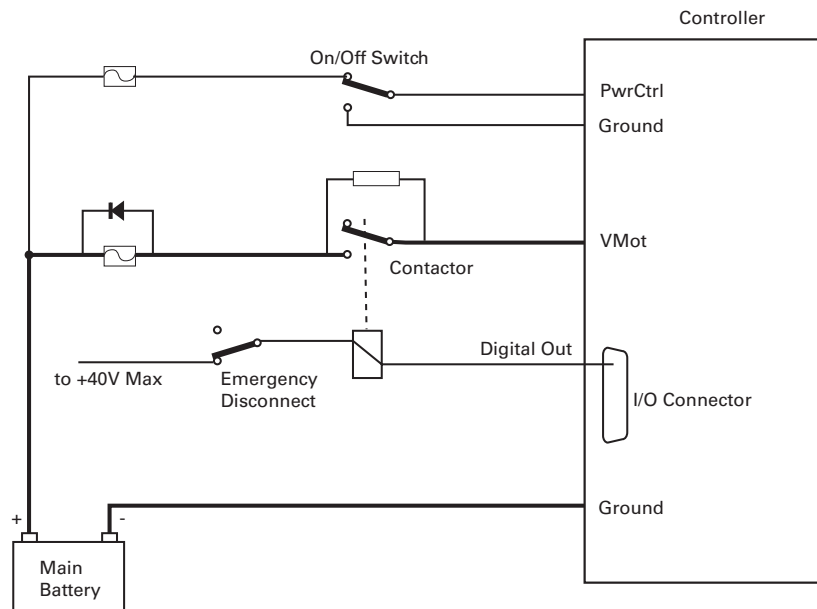

FIGURE 2-8. Self protection circuit using a contactor

Note: Digital outputs are rated 40V max. If the battery voltage is higher than 40V, the relay must be connected to the + of an alternate power source of lower voltage.

The controller must have the Power Control input wired to the battery so that it can operate and communicate independently of the power stage. The controller's processor will then activate the contactor coil through a digital output configured to turn on when the "No MOSFET Failure" condition is true. The controller will automatically deactivate the coil if the output is expected to be off and the battery current is above 500mA to 2.5A (depending on the controller model) for more than 0.5s.

The contactor must be rated high enough so that it can cut the full load current. For even higher safety, additional precaution should be taken to prevent and to detect fused contactor blades.

This contactor circuit will only detect and protect against damaged output stage conditions. It will not protect against all other types of fault. Notice therefore, the presence of an emergency switch in series with the contactor coil. This switch should be operated manually or remotely, as discussed in the Manual Emergency Power Disconnect the Remote Emergency Power Disconnect and the Protection using Supervisory Microcomputer earlier in this section of the manual.

Using this contactor circuit, turning off the controller will normally deactivate the digital output and this will cut the power to the controller's output stage.

Important Warning

Fully autonomous and unsupervised systems cannot depend on electronics alone to ensure absolute safety. While a number of techniques can be used to improve safety, they will minimize but never totally eliminate risks. Such systems must be mechanically designed so that no moving parts can ever cause harm in any circumstances.

Safe Torque-Off (STO)

Safe Torque Off is a safe method for switching controller in a state where no torque is generated, regardless whether the controller is operating normally or is faulty. This function is a mechanism that prevents the drive from restarting unexpectedly. STO has the immediate effect that the drive cannot supply any torque-generating energy. STO can be used wherever the drive will be brought to a standstill in a sufficiently short time by the load torque or friction or where coasting down of the drive is not relevant to safety. STO enables safe working and has a wide range of use in motion control/ systems with moving axes. The advantage of the integrated STO safety function compared with standard safety technology using electromechanical switchgear is the elimination of separate components and the effort that would be required to wire and service them. Because of the rapid electronic switching times, the function has a shorter switching time than the electromechanical components in a conventional solution.

Specific motor controllers implement Safe Torque-Off (STO) circuitry, which is under certification from TUV (T-version - Certification No. M6A 104504 0001 Rev. 00). STO is the most common safety function, meant for motor controllers, ensuring that upon trigger no torque will be generated even after the controller power cycle. For controllers without the specific circuit the STO is implemented in firmware alone and digital inputs 1 and 2 are usually used (check controller's datasheet).

Safe Torque Off (STO) on Roboteq Controllers

Two digital inputs on the user IO connector can be used to put the controller in a state where the motor is deprived of energy.

The two inputs, labeled STO1 and STO2 must both be brought and maintained at a logic level 1 for the controller to be active. If any one or both of these lines are at 0, the output is de-energized.

The STO circuit operates independently of the MCU. It will always override the MCU, whether the MCU is processing normally, or is in a hardware or firmware fault condition.

The STO circuit works by controlling the voltage supply to the controller's MOSFET drivers. When both STO1 and STO2 are at logic 1 level, the MOSFET driver are supplied with power. When either or both STO1 and STO2 are at logic level 0, the MOSFET driver power is cut, and the MOSFETs gates can no longer be above the ON threshold level, regardless of the MCU activity.

Accordingly, the STO circuit is built with redundancy and will continue to function if any one component is faulty, anywhere in the STO circuit or elsewhere in the controller.

Activating STO

By factory default STO is disabled. It must be enabled by removing the jumper located on the controller's PCB. STO is activated by removing power (logic level 0) to both STO inputs. In order for controller to monitor STO state, this function must be activated through Roborun+ Utility or serial command (check command section). The controller will immediately stop generation of torque in the motor. STO functionality is only available in the T version of the controller.

Deactivating STO

STO is deactivated by applying a voltage (logic level 1) to both STO inputs. After this a new start command has to be given to turn the motor. It can be disabled by connecting the jumper located on the controller's PCB. After that user should disable the function through Roborun+ Utility or serial command (check command section).

Constraints when using STO

- The STO feature is only approved for use with Brushless DC or AC Induction motors.
- All voltages attached to the controller need to fulfil SELV or PELV requirements.
- After first installation and at least every 3 months the test as described in chapter 14 has to be conducted.

Sto Failure Messages

In case a failure is detected in the STO circuit the following failure message will be visible according on how the user operates the controller.

1. Status LED on Controller

The status LED pattern will be the below in case of STO failure



- STO Fault LED at Roborun+ utility in failure

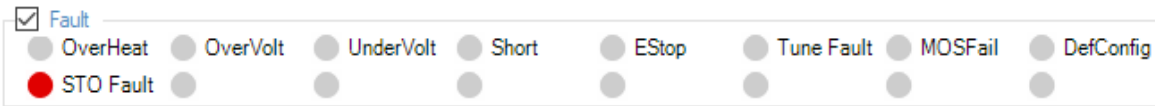

This failure can have several internal and external reasons. If the failure is shown please check the cabling and the signals to STO 1 and STO 2. Both signals must have at all times the same level.

- Check that the STO jumper is set correctly and STO is configured correctly
- Check wiring
- Check cabling for short circuits or open circuits

If the failure persists, contact Roboteq support.

IMPORTANT WARNING

Same status LED pattern is used for undervoltage and overvoltage faults and that should not be confusing. If STO fault appear it is normal for the controller voltage to be off and undervoltage fault to trigger. Either way this Status LED pattern indicates a situation that should be treated with caution.

Firmware implementation

The STO circuit will operate regardless of the MCU activity. However, when operating normally the MCU will perform the following functions:

- Self-test that the STO circuits and switches are functional. This is done every time the controller is powered on. It can also be done at any time during the controller from external user commands from the system's PC or PLC (check command section). The self-test can also be initiated by the controller itself using its scripting language, at periodic time intervals, or any other user-define rule(s).

If the self-test fails, the controller will stop driving the MOSFETs and set a fault flag that can be monitored by the PLC/Computer. It can also activate one of its digital outputs to indicate the fault.
- The STO inputs are monitored continuously every 1ms. If one or both STO inputs are at level zero and the MOSFET driver supply voltage has not dropped, an STO fault is detected. The STO fault flag is set. A user digital output can be activated to indicate the fault.

Installation – Maintenance

The STO circuit needs to be tested before first installation and at least every 3 months according to the below sequence:

1. Activate STO (both logic level 0)
2. Check that STO is active (through Roborun+ Utility/Serial)

3. Check that there is no STO fault present (through Roborun+ Utility/Serial)
4. Deactivate STO 1 and STO 2 (both logic level 1)
5. Check that STO is not active and that there is no STO fault present (through Roborun+ Utility/Serial).

SAFETY INSTALLATION

It is required that the controller has to be placed in an enclosure that can provide IP54 protection.

SAFETY REGISTRATION

It is required that STO end user should follow up www.roboteq.com and register to site/forum for any news about safety function.

STO Voltage source specification attention

In order to have maximum response at STO implementation, user/installer/integrator should use voltage source with low output capacitance. In any other case, latency in activation might occur.

Compliance and Safety Metrics

The STO function is compliant to:

- IEC 61800-5-2:2007, SIL 3
- IEC 61508:2010, SIL 3
- IEC 62061:2005, SIL 3
- ISO 13849-1:2015, Category 3 Performance Level e

Metric acc. To IEC 61508, IEC 61800-5-2, IEC 62061	Value
SIL	Up to 3
PFH	5 FIT
Mission Time and Proof Test Interval	20 years
Performance Level	e
Category	3
MTTFD	>100 years

Technical Data

Specification	Value
STO Input High Level	6V to 30V
STO Input Low Level	0V to 1V
STO Response Time	< 5msec
Operating Temperature	-20°C to 55°C
Storage Temperature	-20°C to 70°C
IP degree	IP40
Humidity	5% to 95% non-condensing
Maximum altitude	2000m
STO cable length	≤ 3m (1)
EMC immunity	According to IEC 61800-3:2017 and IEC 61800-5-2:2007 Annex E
CE Declaration of conformity	Available at www.roboteq.com
All connected cables must have length <3m	

SECTION 3

Connecting Sensors and Actuators to Input/Outputs

This section describes the various inputs and outputs and provides guidance on how to connect sensors, actuators or other accessories to them.

Controller Connections

The controller uses a set of power connections DSub and plastic connectors for all necessary connections.

The power connections are used for connecting to the batteries and motor, and will typically carry large current loads. Details on the controller's power wiring can be found at "Connecting Power and Motors to the Controller" section of this manual.

The DSub and plastic connectors are used for all low-voltage, low-current connections to the Radio, Microcontroller, sensors, and accessories. This section covers only the connections to sensors and actuators.

For information on how to connect the RS232 or the RS485 ports, see "Serial (RS232/RS485/TCP/USB) Operation" section.

The remainder of this section describes how to connect sensors and actuators to the controller's low-voltage I/O pins that are located on the DSub and plastic connectors.

Controller's Inputs and Outputs

The controller includes several inputs and outputs for various sensors and actuators. Depending on the selected operating mode, some of these I/Os provide command, feedback and/or safety information to the controller.

When the controller operates in modes that do not use these I/Os, these signals are ignored or can become available via the RS232/RS485/TCP/USB port for user application. Below is a summary of the available signals and the modes in which they are used by the controller. The actual number of the signal of each type, voltage or current specification, and their position on the I/O connector is given in the controller datasheet.

TABLE 3-1. Controller's IO signals and definitions

Signal	I/O type	Use/Activation
DOUT1 to DOUTn	Digital Output	<ul style="list-style-type: none"> - Activated when motor(s) is powered - Activated when motor(s) is reversed - Activated when overtemperature - Activated when overvoltage - Mirror Status LED - Deactivates when output stage fault - User activated (RS232/RS485/TCP/USB or via scripting)
DIN1 to DINn	Digital Input	<ul style="list-style-type: none"> - Safety Stop - Emergency stop - Motor Stop (deadman switch) - Invert motor direction - Forward or reverse limit switch - Run MicroBasic Script - Load Home counter
AIN1 to AINn	Analog Input	<ul style="list-style-type: none"> - Command for the motor(s) - Speed or position feedback - Trigger Action similar to Digital Input if under or over user-selectable threshold
PIN1 to PINn	Pulse Input	<ul style="list-style-type: none"> - Command for the motor(s) - Speed or position feedback - Trigger Action similar to Digital Input if under or over user selectable threshold
ENC1a/b to ENC2a/b	Encoder Inputs	<ul style="list-style-type: none"> - Speed or position feedback - Trigger action similar to Digital Input if under or over user-selectable count threshold

Connecting devices to Digital Outputs

Depending on the controller model, 2 to 8 Digital Outputs are available for multiple purposes. The Outputs are Open Drain MOSFET outputs capable of driving over 1A at up to 24V. See datasheet for detailed specifications.

Since the outputs are Open Drain, the output will be pulled to ground when activated. The load must therefore be connected to the output at one end and to a positive voltage source (e.g. a 24V battery) at the other.

Connecting Resistive Loads to Outputs

Resistive or other non-inductive loads can be connected simply as shown in the diagram below.

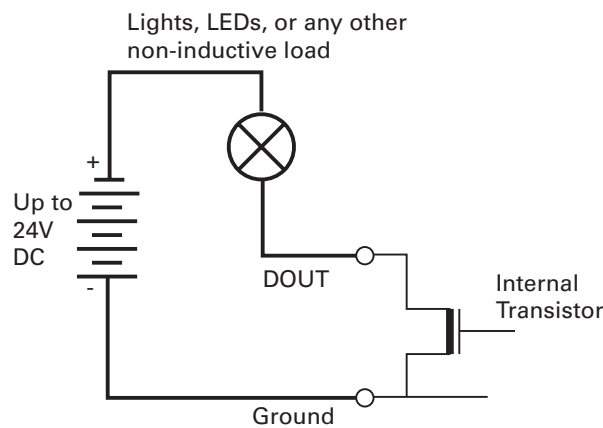

FIGURE 3-1. Connecting resistive loads to Dout pins

Connecting Inductive loads to Outputs

The diagrams on Figure 3-2 show how to connect a relay, solenoid, valve, small motor, or other inductive load to a Digital Output:

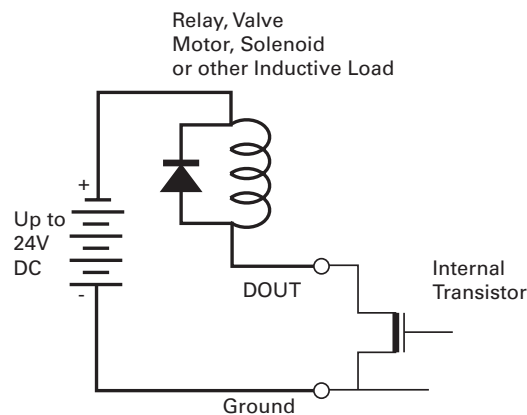

FIGURE 3-2. Connecting inductive loads to Dout pins

Important Warning

Overvoltage spikes induced by switching inductive loads, such as solenoids or relays, will destroy the transistor unless a protection diode is used.

Connecting Switches or Devices to Inputs shared with Outputs

On HDCxxxx and HBLxxxx controllers, Digital inputs DIN12 to DIN19 share the connector pins with digital outputs DOUT1 to DOUT8. When the digital outputs are in the Off state, these outputs can be used as inputs to read the presence or absence of a voltage at these pins.

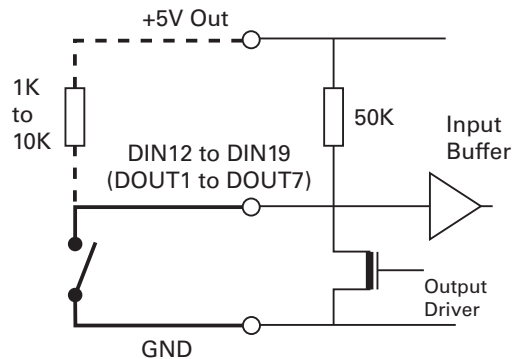

FIGURE 3-3. Switch wiring to inputs shared with outputs

For better noise immunity, an external pull up resistor should be installed even though one is already present inside the controller.

Important Warning

Do not activate an output when it is used as input. If the input is connected directly to a positive voltage when the output is activated, a short circuit will occur. Always pull the input up via a resistor.

Connecting Switches or Devices to direct Digital Inputs

The controller Digital Inputs are high impedance lines with a pull down resistor built into the controller. Therefore it will report an Off state if unconnected. A simple switch as shown in Figure 3-4 can be used to activate it. When a pull up switch is used, for better noise immunity, an external pull down resistor should be installed even though one is already present inside the controller.

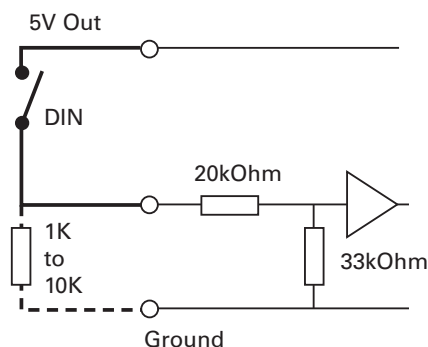

FIGURE 3-4. Pull up (Active High) switch wirings to DIN pins

A pull up resistor must be installed when using a pull down switch.

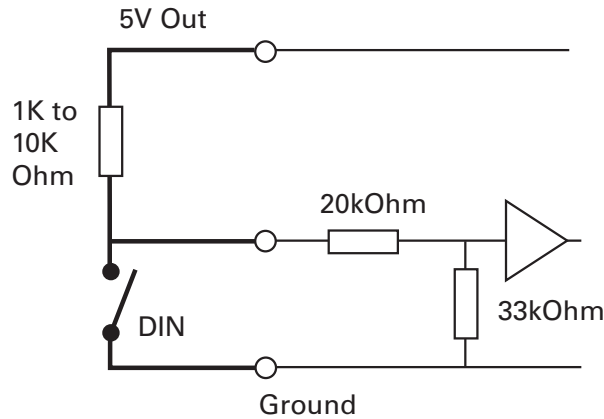

FIGURE 3-5. Pull down (Active Low) switch wirings to DIN pins

Connecting a Voltage Source to Analog Inputs

Connecting sensors with variable voltage output to the controller is simply done by making a direct connection to the controller's analog inputs. When measuring absolute voltages, configure the input in "Absolute Mode" using the PC Utility.

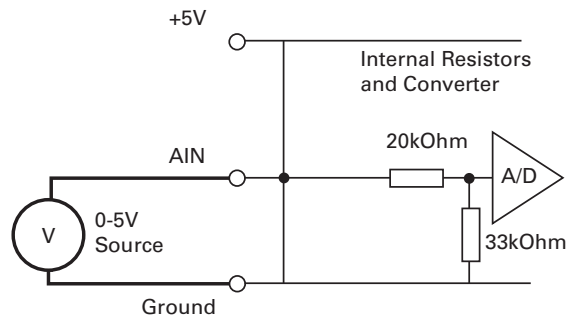

FIGURE 3-6. 0-5V Voltage source connected to Analog inputs

Using external resistors, it is possible to alter the input voltage range to 0V/10V or -10V/+10V.

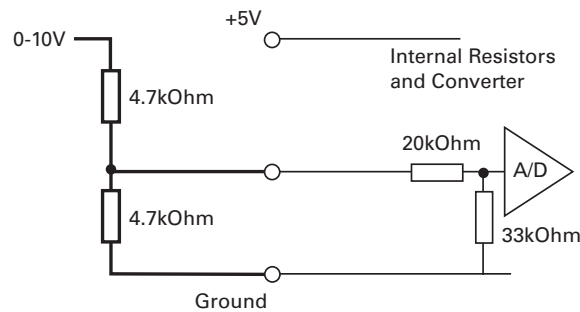

FIGURE 3-7. External resistor circuit for 0 to 10V capture range

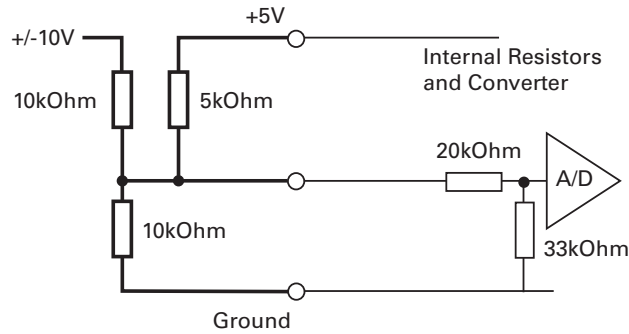

FIGURE 3-8. External resistors circuit for -10V to 10V capture range

Important Notice

On newer motor controllers models, activating the pulse mode on input will also enable a pull up resistor on that input. If the input is also used for analog capture, the analog reading will be wrong. Make sure the pulse mode is disabled on that input.

Reducing noise on Analog Inputs

The Analog inputs are very fast and have a high input resistance. They will therefore easily be disturbed by ambient electrical noise and this will cause the analog reading to be fluctuating. Use shielded cables between the input and the analog sensor. Add a 1uF capacitor between the input pin and the GND pin. With good shielding and filtering, a signal stable to within +/-5V or better can generally be achieved.

Connecting Potentiometers to Analog Inputs

Potentiometers mounted on a foot pedal or inside a joystick are an effective method for giving the command to the controller. In closed loop mode, a potentiometer is typically used to provide position feedback information to the controller.

Connecting the potentiometer to the controller is as simple as shown in the diagram in Figure 3-9.

The potentiometer value is limited at the low end by the current that will flow through it and which should ideally not exceed 5 or 10mA. If the potentiometer value is too high, the analog voltage at the pot's middle point will be distorted by the input's resistance to ground of 53K. A high value potentiometer also makes the input sensitive to noise, particularly if wiring is long. Potentiometers of 1K or 5K are recommended values.

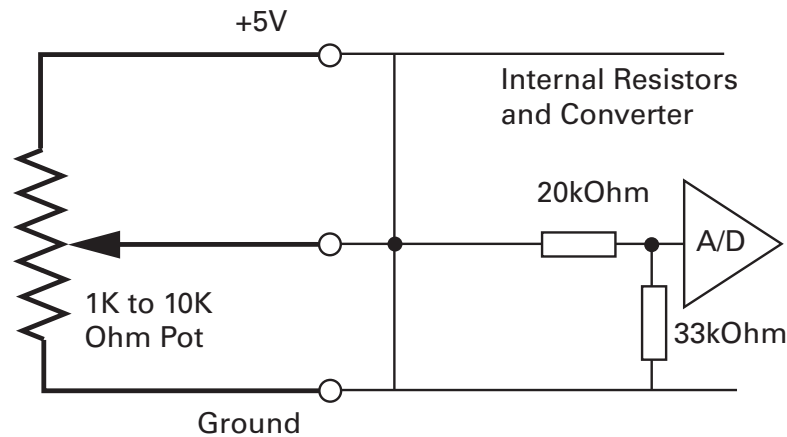

FIGURE 3-9. Potentiometer wiring

Because the voltage at the potentiometer output is related to the actual voltage at the controller's 5V output, configure the analog input in "Relative Mode". This mode measures the actual voltage at the 5V output in order to eliminate any imprecision due to source voltage variations. Configure using the PC Utility.

Connecting Potentiometers for Commands with Safety band guards

When a potentiometer is used for sensing a critical command (Speed or Brake, for example) it is critically important that the controller reverts to a safe condition in case wiring is sectioned. This can be done by adding resistors at each end of the potentiometer so that the full 0V or the full 5V will never be present, during normal operation, when the potentiometer is moved end to end.

Using this circuit shown below, the Analog input will be pulled to 0V if the two top wires of the pot are cut, and pulled to 5V if the bottom wire is cut. In normal operation, using the shown resistor values, the analog voltage at the input will vary from 0.2V to 4.8V.

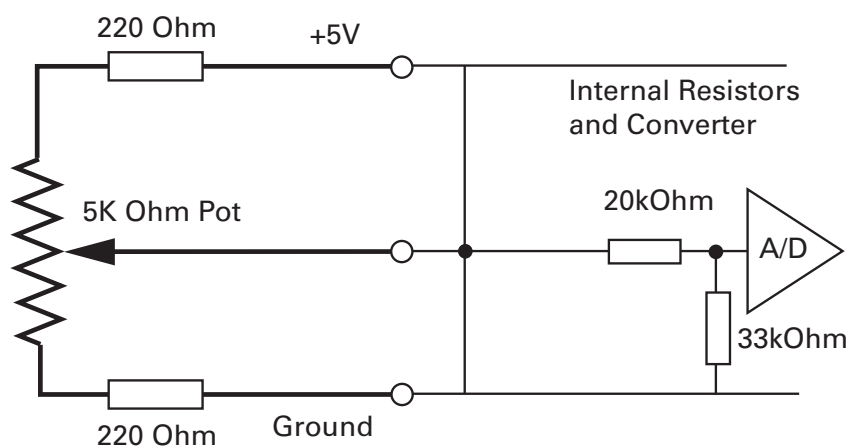

FIGURE 3-10. Potentiometer wiring in Position mode

The controller's analog channels are configured by default so that the min and max command range is from 0.25V to 4.75V. These values can be changed using the PC configuration utility. This ensures that the full travel of the pot is used to generate a command that spans from full min to full max.

If the Min/Max safety is enabled for the selected analog input, the command will be considered invalid if the voltage is lower than 0.1V or higher than 4.9. These values cannot be changed.

Connecting Tachometer to Analog Inputs

When operating in closed loop speed mode, tachometers can be connected to the controller to report the measured motor speed. The tachometer can be a good quality brushed DC motor used as a generator. The tachometer shaft must be directly tied to that of the motor with the least possible slack.

Since the controller only accepts a 0 to 5V positive voltage as its input, the circuit shown in Figure 3-11 must be used between the controller and the tachometer: a 10kOhm potentiometer is used to scale the tachometer output voltage to -2.5V (max reverse speed) and +2.5V (max forward speed). The two 1kOhm resistors form a voltage divider that sets the idle voltage at mid-point (2.5V), which is interpreted as the zero position by the controller.

With this circuitry, the controller will see 2.5V at its input when the tachometer is stopped, 0V when running in full reverse, and +5V in full forward.

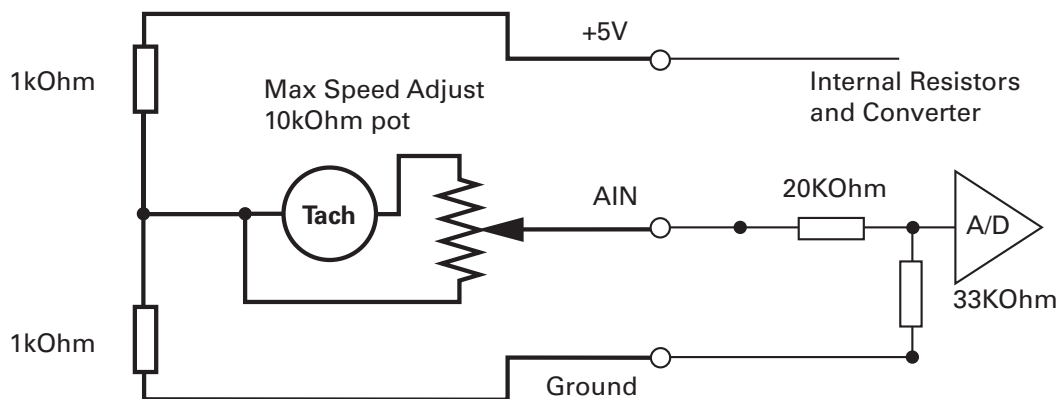

FIGURE 3-11. Tachometer wiring diagram

The tachometers can generate voltages in excess of 2.5 volts at full speed. It is important, therefore, to set the potentiometer to the minimum value (cursor all the way down per this drawing) during the first installation.

Since in closed loop control the measured speed is the basis for the controller's power output (i.e. deliver more power if slower than the desired speed, less if higher), an adjustment and calibration phase is necessary. This procedure is described in "Closed Loop Speed Mode" section of this manual.

Important Warning

The tachometer's polarity must be such that a positive voltage is generated to the controller's input when the motor is rotating in the forward direction. If the polarity is inverted, this will cause the motor to run away to the maximum speed as soon as the controller is powered and eventually trigger the closed loop error and stop. If this protection is disabled, there will be no way of stopping it other than pressing the emergency stop button or disconnecting the power.

Connecting External Thermistor to Analog Inputs

Using external thermistors, the controller can be made to supervise the motor's temperature and cut the power output in case of overheating. Connecting thermistors is done according to the diagram shown in Figure 3-12. Use a 10kOhm Negative Coefficient Thermistor (NTC) with the temperature/resistance characteristics shown in the table below. Recommended part is Vishay NTCALUG03A103GC, Digikey item BC2381-ND.

TABLE 3-1. Recommended NTC characteristics

Temp (°C)	-25	0	25	50	75	100
Resistance (kOhm)	129	32.5	10.00	3.60	1.48	0.67

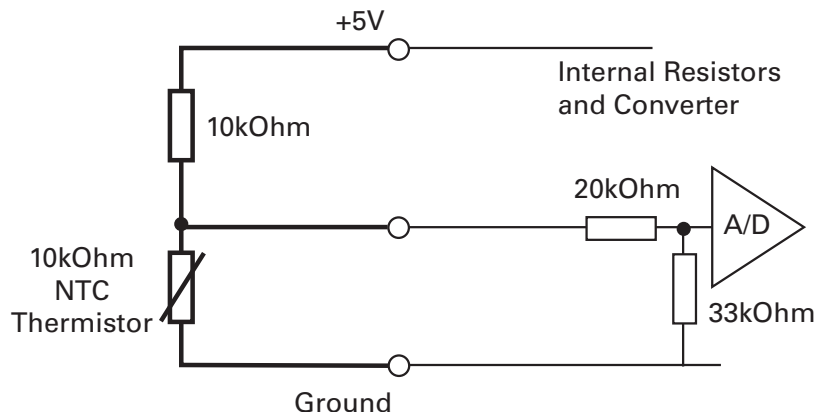

FIGURE 3-12. NTC Thermistor wiring diagram

Thermistors are non-linear devices. Using the circuit described in Figure 12, the controller will read the following values according to the temperature. For best precision, the analog input must be configured to read in Relative Mode.

The analog input must be configured so that the minimum range voltage matches the desired temperature and that action be triggered when that limit is reached. For example 500mV for 80oC, according to the table. The action can be any of the actions in the list. An emergency or safety stop (i.e. stop power until the operator moves command to 0) would be a typical action to trigger.

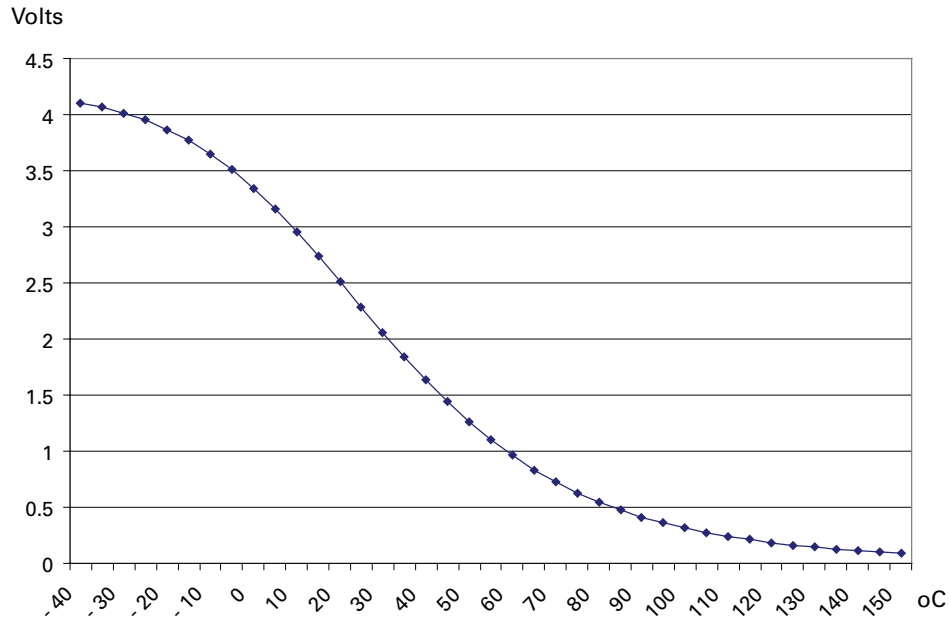

FIGURE 3-13. Voltage reading by Controller vs NTC temperature

Note: The voltage values in this chart are provided for reference only and may vary based on the Thermistor model/brand and the resistor precision. It is recommended that you verify and calibrate your circuit if it is to be used for safety protection.

Using the Analog Inputs to Monitor External Voltages

The analog inputs may also be used to monitor the battery level or any other DC voltage. If the voltage to measure is up to 5V, the voltage can be brought directly to the input pin. To measure higher voltage, insert two resistors wired as a voltage divider. The figure shows a 10x divider capable of measuring voltages up to 50V.

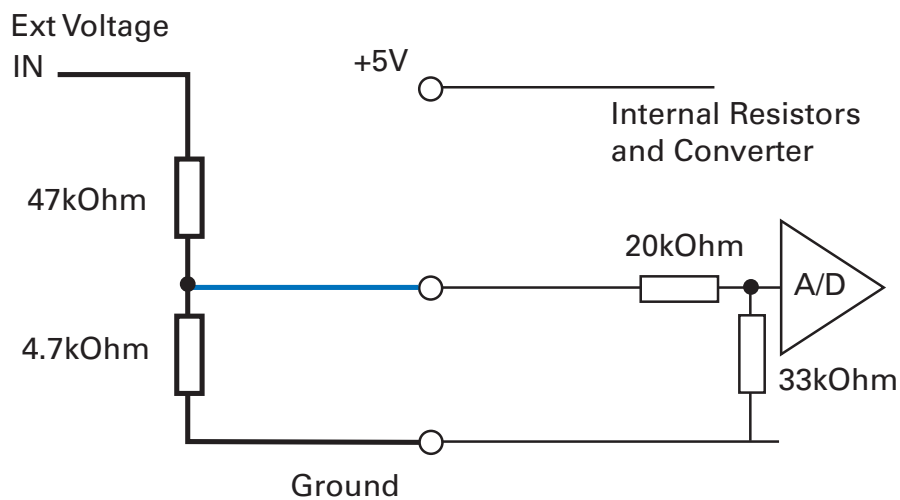

FIGURE 3-14. Battery Voltage monitoring circuit

Connecting Sensors to Pulse Inputs

The controller has several pulse inputs capable of capturing Pulse Length, Duty Cycle or Frequency with excellent precision. Being a digital signal, pulses are also immune to noise compared to analog inputs.

Important Notice

On newer motor controllers models, activating the pulse mode on input will also enable a pull up resistor on that input. If the input is also used for analog capture, the analog reading will be wrong.

Connecting to RC Radios

The pulse inputs are designed to allow direct connection to an RC radio without additional components.

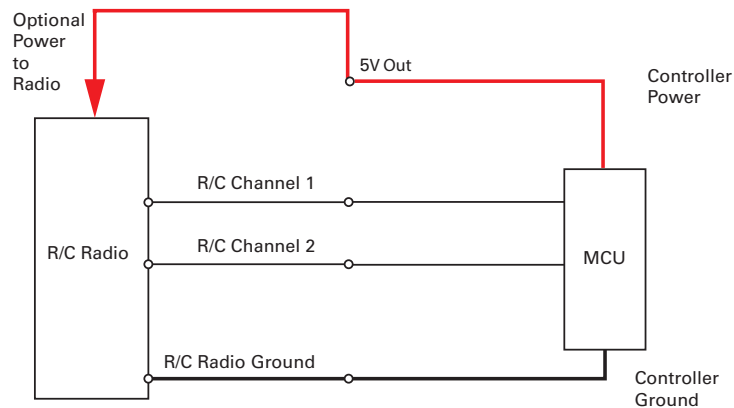

FIGURE 3-15. RC Radio powered by controller electrical diagram

Connecting to PWM Joysticks and Position Sensors

The controller's pulse inputs can also be used to connect to sensors with PWM outputs. These sensors provide excellent noise immunity and precision. When using PWM sensors, configure the pulse input in Duty Cycle mode. Beware that the sensor should always be pulsing and never output a steady DC voltage at its ends. The absence of pulses is considered by the controller as a loss of signal.

Connecting SSI Sensors

SSI Sensors Overview

SSI sensors are absolute encoders that send their data using Synchronous Serial Interface (SSI). Using SSI protocol offers reduced wiring and EMI immunity. SSI sensors as absolute encoders they report a signal respective to the shaft position and can be used in both multi-turn and single-turn applications. Roboteq controllers support the use of SSI sensors with resolution up to 16 bits.

Connecting the SSI Sensor

SSI Sensors connect directly to pins present on the controller’s connector. The connector provides 5V power to the sensors and has inputs for the two data and the two clock signals for each sensor. The figure below shows the connection to the SSI Sensor.

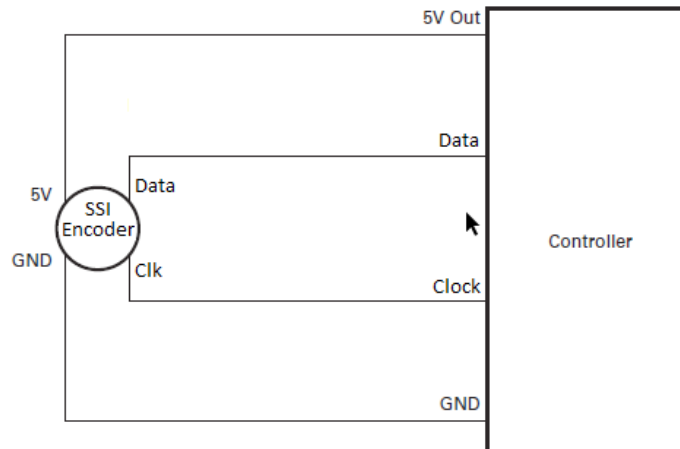

FIGURE 3-16. Controller Connection to typical SSI Encoder

Connecting Optical Encoders

Optical Incremental Encoders Overview

Optical incremental encoders are a means for capturing speed and traveled distance on a motor. Unlike absolute encoders which give out a multi-bit number (depending on the resolution), incremental encoders output pulses as they rotate. Counting the pulses tells the application how many revolutions, or fractions of, the motor has turned. Rotation velocity can be determined from the time interval between pulses or by the number of pulses within a given time period. Because they are digital devices, incremental encoders will measure distance and speed with perfect accuracy.

Since motors can move in forward and reverse directions, it is necessary to differentiate the manner that pulses are counted so that they can increment or decrement a position counter in the application. Quadrature encoders have dual channels, A and B, which are electrically phased 90° apart. Thus, the direction of rotation can be determined by monitoring the phase relationship between the two channels. In addition, with a dual-channel encoder, a four-time multiplication of resolution is achieved by counting the rising and falling edges of each channel (A and B). For example, an encoder that produces 250 Pulses per Revolution (PPR) can generate 1,000 Counts per Revolution (CPR) after quadrature.

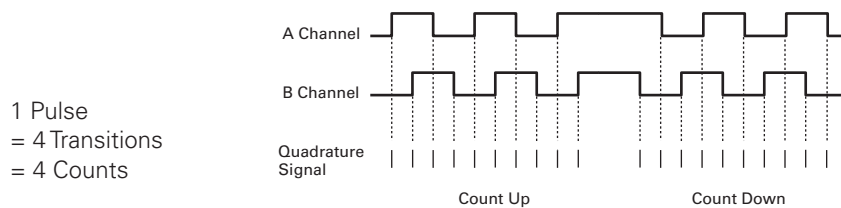

FIGURE 3-17. Quadrature encoder output waveform

The figure below shows the typical construction of a quadrature encoder. As the disk rotates in front of the stationary mask, it shutters light from the LED. The light that passes through the mask is received by the photo detectors. Two photo detectors are placed side by side so that the light making it through the mask hits one detector after the other to produce the 90° phased pulses.

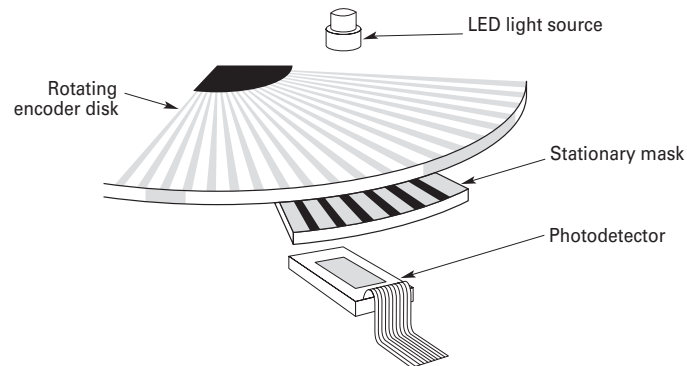

FIGURE 3-18. Typical quadrature encoder construction

Unlike absolute encoders, incremental encoders have no retention of absolute position upon power loss. When used in positioning applications, the controller must move the motor until a limit switch is reached. This position is then used as the zero reference for all subsequent moves.

Recommended Encoder Types

The module may be used with most incremental encoder modules as long as they include the following features:

- Two quadrature outputs (Ch A, Ch B), single ended
- 3.0V minimum swing between 0 Level and 1 Level on quadrature output
- 5VDC operation. 50mA or less current consumption per encoder

More sophisticated incremental encoders with index and other features may be used, however these additional capabilities will be ignored.

The choice of encoder resolution is very wide and is constrained by the module's maximum pulse count at the high end and measurement resolution for speed at the low end.

Specifically, the controller's encoder interface can process 1 million counts per second, unless otherwise specified in the product datasheet.

Commercial encoders are rated by their numbers of "Pulses per Revolution" (also sometimes referred to as "Number of Lines" or "Cycles per Revolution"). Carefully read the manufacturer's datasheet to understand whether this number represents the number of pulses that are output by each channel during the course of a 360 degrees revolution rather than the total number of transitions on both channels during a 360 degrees revolution. The second number is 4 times larger than the first one.

The formula below gives the pulse frequency at a given RPM and encoder resolution in Pulses per Revolution.

$$\text{Pulse Frequency in counts per second} = \text{RPM} / 60 * \text{PPR} * 4$$

Example: a motor spinning at 10,000 RPM max, with an encoder with 200 Pulses per Revolution would generate:

$$10,000 / 60 * 200 * 4 = 133.3 \text{ kHz}$$

which is well within the 1MHz maximum supported by the encoder input.

An encoder with 200 Pulses per Revolutions is a good choice for most applications.

A higher resolution will cause the counter to count faster than necessary and possibly reach the controller's maximum frequency limit.

An encoder with a much lower resolution will cause speed to be measured with less precision.

Connecting the Encoder

Encoders connect directly to pins present on the controller's connector. The connector provides 5V power to the encoders and has inputs for the two quadrature signals from each encoder. The figure below shows the connection to the encoder.

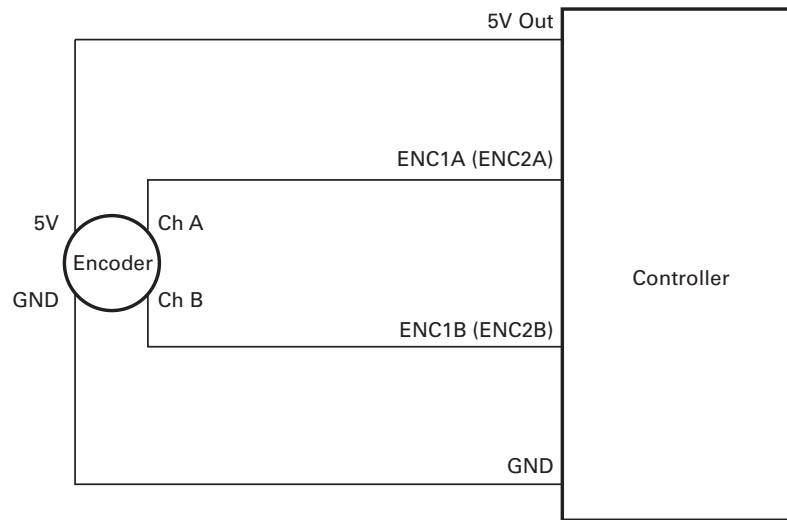

FIGURE 3-19. Controller connection to typical Encoder

For several controller models, the Encoder inputs are by default mapped in Molex connector. In order to be able to use encoders and SSI sensors at the same time (see "MLX" in the command reference section), the encoders can be mapped to DB25 connector pins where pulse inputs are.

Cable Length and Noise Considerations

The cable should not exceed one 3' (one meter) to avoid electrical noise to be captured by the wiring. A ferrite core filter should be inserted near the controller for length beyond 2' (60 cm). For longer cable length use an oscilloscope to verify signal integrity on each of the pulse channels and on the power supply.

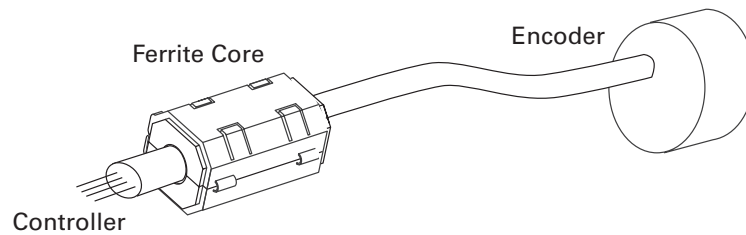

FIGURE 3-20. Use ferrite core on cable length beyond 2' or 60cm

Important Warning

Excessive cable length will cause electrical noise to be captured by the controller and cause erratic functioning that may lead to failure. In such a situation, stop operation immediately.

Motor - Encoder Polarity Matching

When using encoders for closed loop speed or position control, it is imperative that when the motor is turning in the forward direction, the counter increments its value and a positive speed value is measured. The counter value can be viewed using the PC utility.

If the Encoder counts backward when the motor moves forward, correct this by either:

- 1- Swapping Channel A and Channel B on the encoder connector. This will cause the encoder module to reverse the count direction,
- 2- Enter a negative number in the PPR configuration will also cause the counter to count in the reverse direction
- 3- Swapping the leads on the motor. This will cause the motor to rotate in the opposite direction.

SECTION 4

I/O Configuration and Operation

This section discusses the controller's digital and analog inputs and output and how they can be used.

Basic Operation

The controller's operation can be summarized as follows:

- Receive commands from a radio receiver, joystick or a microcomputer
- Activate the motor according to the received command
- Perform continuous check of fault conditions and adjust actions accordingly
- Report real-time operating data

The diagram below shows a simplified representation of the controller's internal operation. The most noticeable feature is that the controller's serial, digital, analog, pulse, and encoder inputs may be used for practically any purpose.

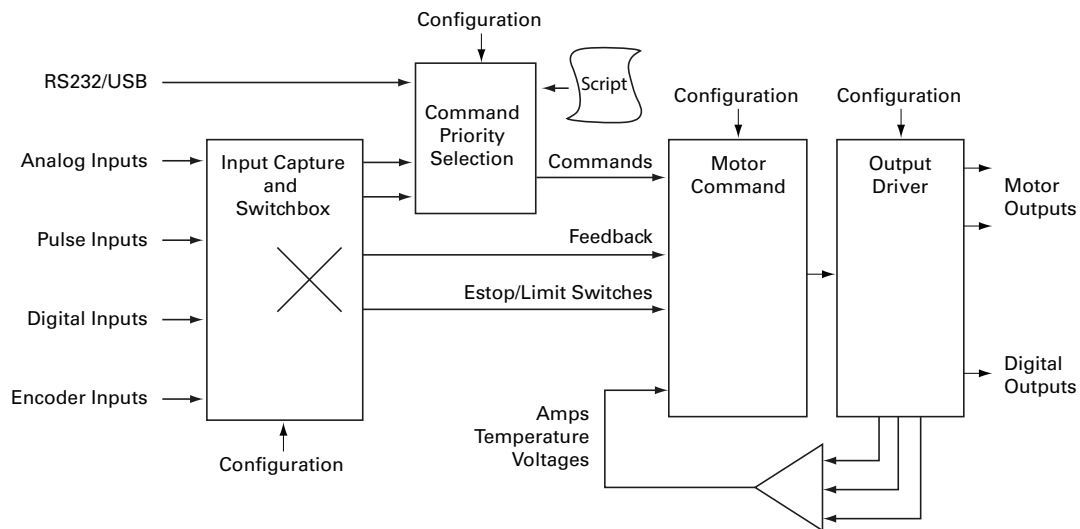

FIGURE 4-1. Simplified representation of the controller's internal operation

Practically all operating configurations and parameters can be changed by the user to meet any specific requirement. This unique architecture leads to a very high number of possibilities. This section of the manual describes all the possible operating options.

Input Selection

As seen earlier in the controller’s simplified internal operating diagram on Figure 4-1, any input can be used for practically any purpose. All inputs, even when they are sharing the same pins on the connector, are captured and evaluated by the controller. Whether input is used, and what it is used for, is set individually using the descriptions that follow.

Important Notice

On shared I/O pins, there is nothing stopping one input to be used as analog or pulse at the same time or for two separate inputs to act identically or in conflict with one another. While such an occurrence is normally harmless, it may cause the controller to behave in an unexpected manner and/or cause the motors not to run. Care must be exercised in the configuration process to avoid possible redundant or conflictual use.

Digital Inputs Configurations and Uses

Each of the controller’s digital Inputs can be configured so that they are active high or active low. Each output can also be configured to activate one of the actions from the list in the table below. In multi-channel controller models, the action can be set to apply to any or all motor channels.

TABLE 4-1. Digital Input Action List

Action	Applicable Channel	Description
No Action	-	Input causes no action
Safety Stop	Selectable	Stops the selected motor(s) channel until the command is moved back to 0 or command direction is reversed
Emergency stop	All	Stops the controller entirely until the controller is powered down, or a special command is received via the serial port
Motor Stop (deadman switch)	Selectable	Stops the selected motor(s) while the input is active. Motor resumes when input becomes inactive
Invert motor direction	Selectable	Inverts the motor direction, regardless of the command mode in use
Forward limit switch	Selectable	Stops the motor until the command is changed to reverse
Reverse limit switch	Selectable	Stops the motor until the command is changed forward
Run script	NA	Start execution of MicroBasic script
Load Home counter	Selectable	Load counter with a Home value

Configuring the Digital Inputs and the Action to use can be done very simply using the PC Utility.

Wiring instructions for the Digital Inputs can be found in "Connecting Switches or Devices to Inputs shared with Outputs" onpage 44

Analog Inputs Configurations and Use

The controller can do extensive conditioning on the analog inputs and assign them to a different use.

Each input can be disabled or enabled. When enabled, it is possible to select the whether capture must be an absolute voltage or relative to the controller's 5V Output. Details on how to wire analog inputs and the differences between the Absolute and Relative captures can be found in "Using the Analog Inputs to Monitor External Voltages" page 50.

TABLE 4-2. Analog Capture Modes

Analog Capture Mode	Description
Disabled	Analog capture is ignored (forced to 0)
Absolute	Analog capture measures real volts at the input
Relative	Analog captured is measured relative to the 5V Output which is typically around 4.8V to 5.1V depending on the controller model and the load. Correction is applied so that an input voltage measured to be the same as the 5V Output voltage is reported at 5.0V

The raw Analog capture then goes through a series of processing shown in the diagram below.

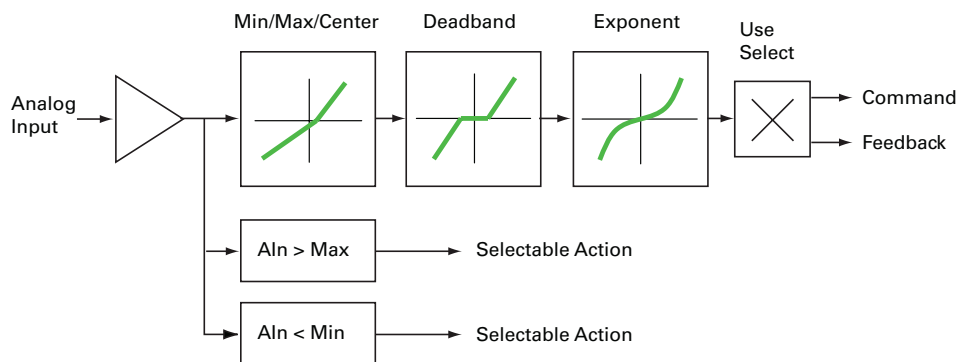

FIGURE 4-2. Analog Input processing chain

Analog Min/Max Detection

An analog input can be configured so that an action is triggered if the captured value is above a user-defined Maximum value and/or under a user-defined Minimum value. The actions that can be selected are the same as these that can be triggered by the Digital Input. See the list and description in Table 4.1, "Digital Input Action List" on page 58.

Min, Max and Center adjustment

The raw analog capture is then scaled into a number ranging from -1000 to +1000 based on user-defined Minimum, Maximum and Center values for the input. For example, setting the minimum to 500mV, the center to 2000mV, and the maximum to 4500mV, will produce the output to change in relation to the input as shown in the graph below

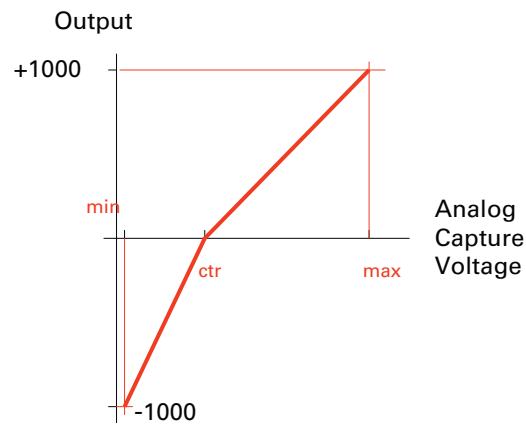

FIGURE 4-3. Analog Input processing chain

This feature allows capturing command or feedback values that match the available range of the input sensor (typically a potentiometer).

For example, this capability is useful for modifying the active joystick travel area. The figure below shows a transmitter whose joystick's center position has been moved back so that the operator has a finer control of the speed in the forward direction than in the reverse position.

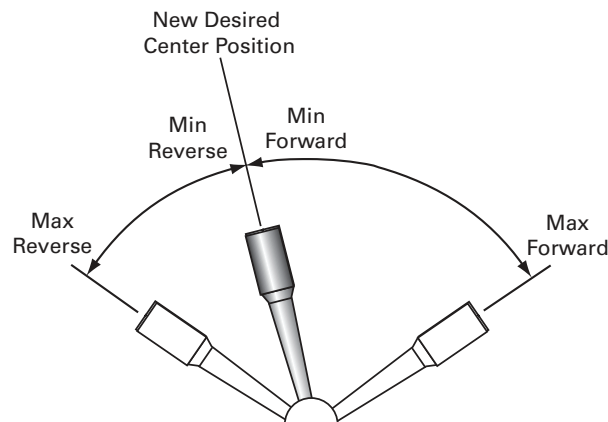

FIGURE 4-4. Calibration example where more travel is dedicated to forward motion

Setting the center value to be the same as the min value makes the input capture only commands in a positive direction. For example if Min = Center = 200 and Max = 4500, the input will convert into 0 when 200 and below, and 1000 above 4500.

The Min, Max, and Center values are defined individually for each input. They can be easily entered manually using the Roborun PC Utility. The Utility also features an Auto-calibration function for automatically capturing these values.

Deadband Selection

The adjusted analog value is then adjusted with the addition of a deadband. This parameter selects the range of movement change near the center that should be considered as a 0 command. This value is a percentage from 0 to 50% and is useful, for example, to allow some movement of a joystick around its center position before any power is applied to a motor. The graph below shows output vs input changes with a deadband of approximately 40%.

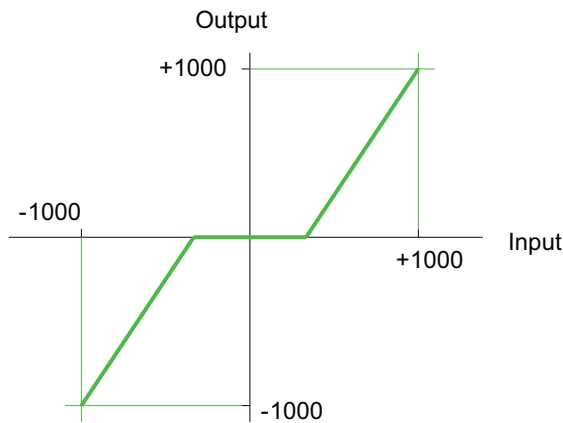

FIGURE 4-5. Effect of deadband on the output

Note that the deadband only affects the start position at which the joystick begins to take effect. The motor will still reach 100% when the joystick is in its full position. An illustration of the effect of the deadband on the joystick action is shown in Figure 4-6 below.

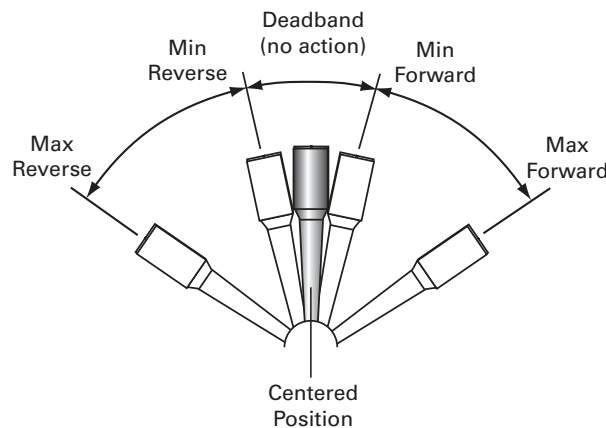

FIGURE 4-6. Effect of deadband on joystick position vs. motor command

The deadband value is set independently for each input using the PC configuration utility.

Command Correction

An optional exponential or a logarithmic adjustment can then be applied to the signal. The exponential correction will make the commands change less at the beginning and become stronger at the end of the joystick movement. The logarithmic correction will have a stronger effect near the start and lesser effect near the end. The linear selection causes no change to the input. There are 3 exponential and 3 logarithmic choices: weak, medium and strong. The graph below shows the output vs input change with exponential, logarithmic and linear corrections.

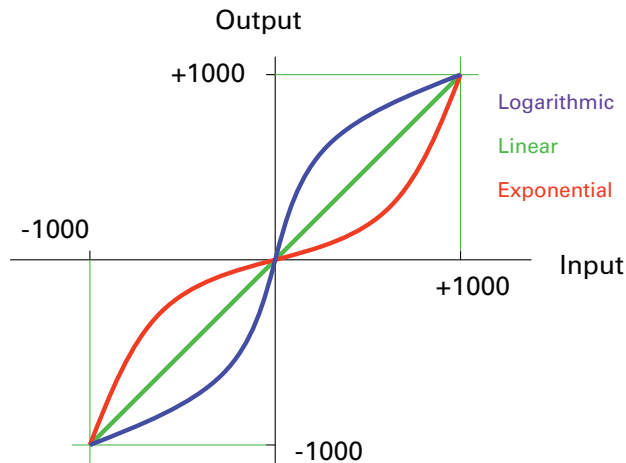

FIGURE 4-7. Effect of exponential / logarithmic correction on the output

The exponential or log correction is selected separately for each input using the PC Configuration Utility.

Use of Analog Input

After the analog input has been fully processed, it can be used as a motor command or, if the controller is configured to operate in a closed loop, as a feedback value (typically speed or position).

Each input can therefore be configured to be used as command or feedback for any motor channel(s). The mode and channel(s) to which the analog input applies are selected using the PC Configuration Utility.

Pulse Inputs Configurations and Uses

The controller's Pulse Inputs can be used to capture pulsing signals of different types.

TABLE 4-3. Analog Capture Modes

Capture Mode	Description	Typical use
Disabled	Pulse capture is ignored (forced to 0)	
Pulse	Measures the On time of the pulse	RC Radio

TABLE 4-3. (continued)

Capture Mode	Description	Typical use
Duty Cycle	Measures the On time relative to the full On/Off period	Hall position sensors and joysticks with pulse output
Frequency	Measures the repeating frequency of pulse	Encoder wheel
MagSensor	Gets Data from MagSensor (MultiPWM, see section 5)	Magnetic Sensor (MGS1600)
BMS	Gets Data from BMS (MultiPWM, see section 5)	Battery Management System (BMS1040)
Pulse Count	Counts the number of Pulses ¹	Quadrature Encoder
Flow Sensor	Gets Data from FlowSensor (MultiPWM, see section 5)	Flow Sensor (FLW100)

¹ The counter will increment every time a pulse is received. The count can be read using the PI query. In order to reset the counter de-configure capture mode to disabled and then back to pulse count.

The capture mode can be selected using the PC Configuration Utility.

The captured signals are then adjusted and can be used as command or feedback according to the processing chain described in the diagram below.

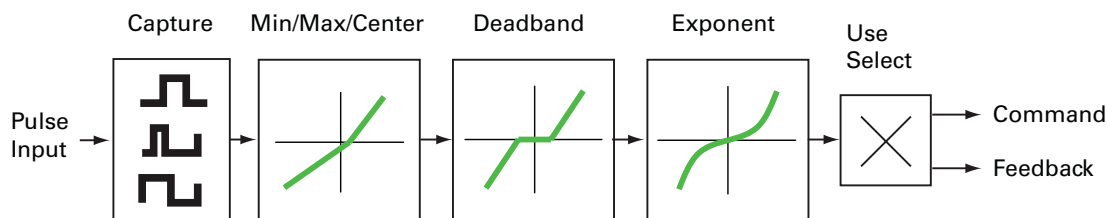

FIGURE 4-8. Pulse Input processing chain

Except for the capture, all other steps are identical to those described for the Analog capture mode.

Use of Pulse Input

After the pulse input has been fully processed, it can be used as a motor command or, if the controller is configured to operate in a closed loop, as a feedback value (typically speed or position).

Each input can therefore be configured to be used as command or feedback for any motor channel(s). The mode and channel(s) to which the analog input applies are selected using the PC Configuration Utility.

Digital Outputs Configurations and Triggers

The controller’s digital outputs can individually be mapped to turn On or Off based on the status of user-selectable internal status or events. The table below lists the possible assignment for each available Digital Output.

Action	Output activation	Typical Use
No action	Not changed by any internal controller events.	Output may be activated using Serial commands or user scripts
Motor(s) is on	When selected motor channel(s) has power applied to it.	Brake release
Motor(s) is reversed	When selected motor channel(s) has power applied to it in reverse direction.	Back-up warning indicator
Overvoltage	When battery voltage above over-limit	Shunt load activation
Overtemperature	When over-temperature limit exceeded	Fan activation. Warning buzzer
Status LED	When status LED is ON	Place Status indicator in visible location.

Encoder Configurations and Use

On controller models equipped with encoder inputs, external encoders enable a range of precision motion control features. See “Connecting Optical Encoders” page 52 for a detailed discussion on how optical encoders work and how to physically connect them to the controller. The diagram below shows the processing chain for each encoder input.

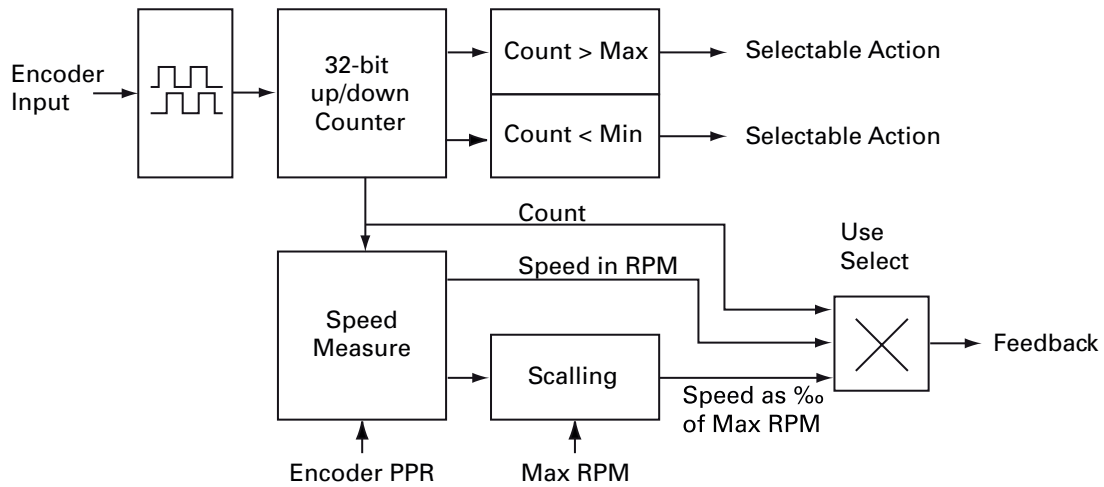

FIGURE 4-9. Encoder input processing

The encoder’s two quadrature signals are processed to generate up and down counts depending on the rotation direction. The counts are then summed inside a 32-bit counter. The counter can be read directly using serial commands and/or can be used as a position feedback source for the closed loop position mode.

The count information is also used to measure rotation speed. Using the Encoder Pulse Per Rotation (PPR) configuration parameter, the output is a speed measurement in actual RPM that is useful in closed loop speed modes where the desired speed is set as a numerical value, in RPM, using a serial command.

Configuring the encoder parameters is done easily using the PC Configuration Utility.

SSI Configuration and Use

On controller models equipped with SSI sensor inputs, SSI sensors enable a range of precision motion control features. See "Connecting SSI Sensors" page 51 for a detailed discussion on how SSI sensors work and how to physically connect them to the controller. The diagram below shows the processing chain for each encoder input.

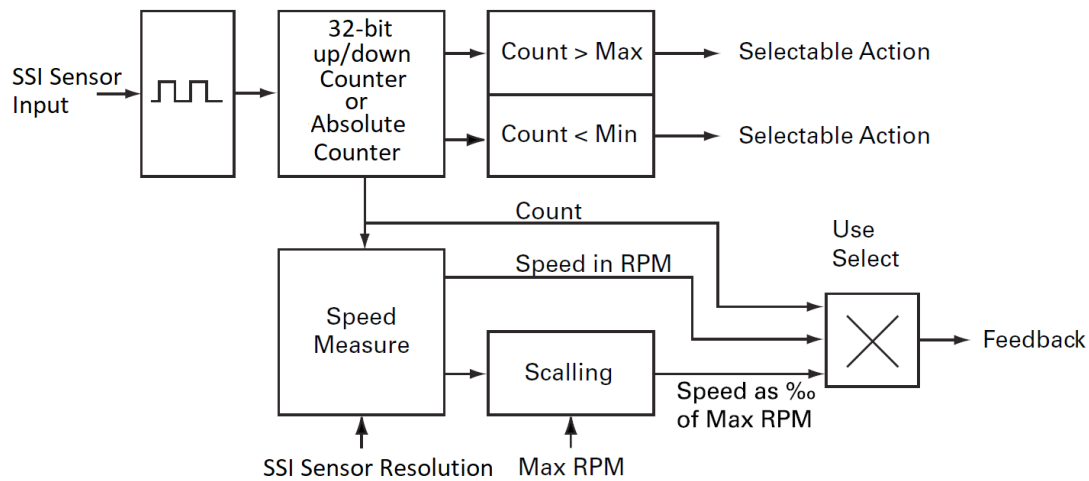

FIGUER 4-10.

The SSI sensor's signal is processed to generate up and down counts depending on the rotation direction. The counts are then summed inside a 32-bit counter. The counter can be read directly using serial commands and/or can be used as a position feedback source for the closed loop position mode.

Also taking into consideration that SSI sensors are absolute sensors, the sensor can be configured in order to indicate the absolute position of the rotor shaft (Absolute Feedback). In that case, the counter holds the absolute position of the rotor shaft.

The count information is also used to measure rotation speed. Using the SSI Sensor Resolution (which represent the counts per revolution, SCPR) configuration parameter, the output is a speed measurement in actual RPM that is useful in closed loop speed modes where the desired speed is set as a numerical value, in RPM, using a serial command.

Configuring the SSI Sensor parameters is done easily using the PC Configuration Utility.

Hall and other Rotor Sensor Inputs

On brushless motor controllers, the Hall or other Rotor position sensor that is used to switch power around the motor windings, are also used to measure speed and distance traveled.

Speed is evaluated by measuring the time between transition of the Hall Sensors. A 32 bit up/down counter is also updated at each Hall Sensor transition.

Speed information picked up from the Hall Sensors can be used for closed loop speed operation without any additional hardware.

Sensor Min Max values

Each Encoder counter, SSI Sensor Counter or Internal Sensor Counter counter can be compared to the respective user-defined Min and/or Max values and trigger an action if these limits are reached. The type actions are the same as these selectable for Digital Inputs and described in "Digital Inputs Configurations and Use" page 58.

Relative Speed

The speed information is also scaled to produce a number ranging from -1000 to +1000 relative to a user-configured arbitrary Max RPM value. For example, with the Max RPM configured as 3000 and the motor rotating at 1500 RPM, the measured relative speed will be 500. Relative speed is useful for closed loop speed mode that uses Analog or Pulse inputs as speed commands.

SECTION 5

Roboteq Products Connection and Operation

This section discusses how to interface one or more Roboteq's products to the motor controller. For the moment the supported products are:

- Magnetic or Optical Sensor (MGS(W)1600, MSW3200, MGSW4800, OTS1600),
- FlowSensor (FLW100),
- Battery Management System (BMS10X0).

Details of each of the above products' operation can be found in the products' datasheets.

Introduction to MGS1600 Magnetic Guide Sensor

Roboteq's Magnetic Guide Sensor is a sensor capable of detecting and reporting the position of a magnetic field along its horizontal axis. The sensor is intended for applications in Automatic Guided Vehicles using inexpensive adhesive magnetic tape to form a guide on the floor. The tape creates an invisible field that is immune to dirt and unaffected by lighting conditions. The sensor can be interfaced directly to any of Roboteq's motor controllers in order to create an effective AGV solution with just two components.

The sensor generates the following information about the track:

- Tape Detect
- Position of Left Track
- Position of Right Track
- Presence of Left Marker
- Presence of Right Marker

Introduction to FLW100 Flowsensor

Roboteq's FLW100 is a high-resolution sensor especially designed for accurate contactless X-Y motion sensing over a surface. The FLW100 is intended as a navigation sensor for a wheeled mobile robot. The sensor works similarly to an optical mouse, but with higher resolution, accuracy and at a greater distance from the reference surface. The sensor uses an embedded infrared camera that is pointed to the floor and measures the displacement distance and speed along the X and Y axis by comparing images at each frame. Distance is measured with 0.1mm resolution with excellent accuracy.

The sensor generates among others the following information:

- X axis distance in mm,
- Y axis distance in mm.

Introduction to BMS10X0 Battery Management System

Roboteq's BMS10x0 is a battery management and protection system for building cost-effective, ultra-efficient and high current power sources using Lithium battery cells. The BMS connects to an array of battery cells at one end, and to a user load at the other. Available in a 40V and 60V versions, it is optimized for 6-cell to 15-cell battery packs.

The product generates among others the following information:

- BMS State of Charge in AmpHours (Ah),
- BMS State Of Charge in percentage,
- BMS Status Flags,
- BMS Switch States.

Available Interfaces

All the above data can be transmitted to the Roboteq controller and other devices using one of the following methods:

Method	To Roboteq Controllers	To PLCs	To PCs
MultiPWM	Preferred	Unsuitable	Unsuitable
Serial	Not Recommended	Preferred	Suitable
CANbus	Suitable	Preferred	Suitable(1)
USB	N/A	Unsuitable	Suitable
Notes:			
1: PC must be fitted with CAN adapter			

MultiPWM interface

The recommended interfacing method to Roboteq motor controller is the MultiPWM mode. As the name implies, this proprietary method uses a succession of variable duty-cycle pulses to carry the data sent by the Magnetic sensor, the FlowSensor or the Battery Management System.

Any of the controller's pulse input can be configured as a MultiPWM input. The diagram below shows how simple this one-wire interfacing is.

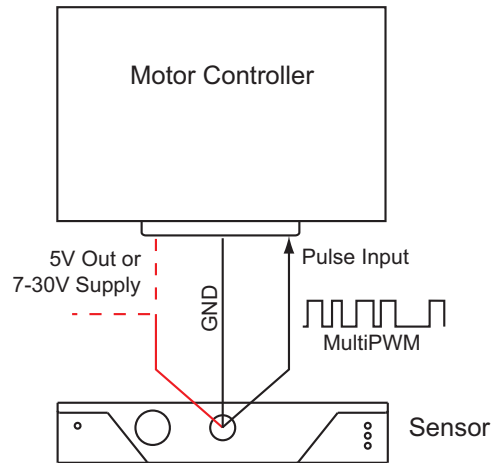
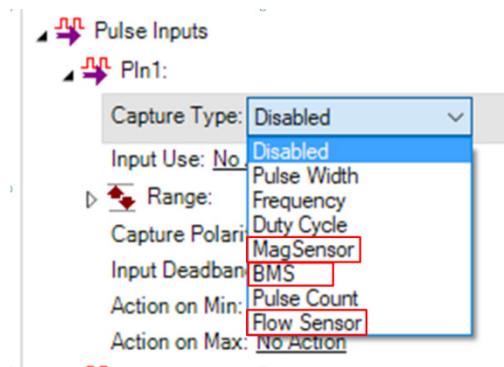

FIGURE 5-1: One-wire interfacing using MultiPWM

Enabling MultiPWM Communication

Magnetic Sensor and Flow Sensor are set to MultiPWM mode in its factory default configuration, while the Battery Management System needs to be explicitly configured. To enable the capture, the selected pulse input on the controller must be configured to the respective option when using the PC utility.



When changing via the console use

`^PMOD cc nn` to enable pulse input `cc` in MultiPWM mode.

Where `nn`:

- 4: For Magnetic Sensor
- 5: For Battery Management System
- 7: For Flow Sensor

Accessing Sensor Information

Once enabled, the pulses are sent continuously by the sensor 100 times per second. The pulses are captured and parsed by the motor controller as they arrive. A real time mirror image of sensor data is then present inside the controller. From there the sensor information can be read using serial, USB, CAN or MicroBasic scripts like any other of the controller's operational parameters.

The following Motor Controller queries are available for reading the captured sensor data.

Magnetic Sensor	
?MGD	Read tape detect
?MGT nn	Read left track when nn= 1 or right track when nn= 2
?MGM nn	Read left marker when nn=1 or right track when nn= 2
Flow Sensor	
?FLW nn	Read X Counter in mm when nn= 1 or Y Counter in mm when nn= 2
Battery Management System	
?BMC	Read BMS State Of Charge in AmpHours (Ah)
?BSC	Read BMS State Of Charge in per cent
?BMF	Read BMS status flags
?BMS	Read BMS switch states

Details on these commands can be found in the Commands Reference section of this manual

Connecting Multiple Similar Sensors

More than one similar sensors can be connected to a single motor controller. For Magnetic sensors, this can be useful in AGV designs that must be able to move in the forward and reverse direction along with the guide. Connecting multiple sensors can be done by connecting each sensor to one of the available pulse input, as shown in the figure below.

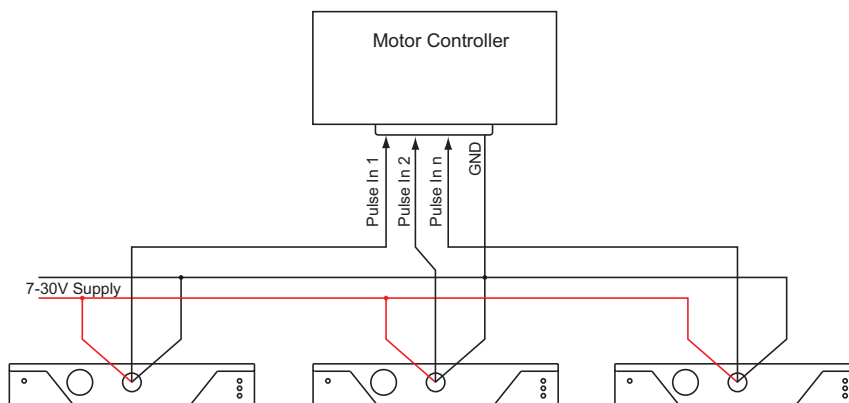

FIGURE 5-2: Connecting multiple sensors to a motor controller

Accessing Multiple Sensor Information Sequentially

Two methods are available for accessing each sensor's data when multiple sensors are connected.

The first method is to only have one sensor enabled at any one time. This is done by enabling and disabling pulse inputs via serial commands or MicroBasic scripting. Examples:

`^PMOD 1 0` : Serial command to Disable Sensor on pulse input 1

`Setconfig(_PMOD, 1, 0)` : Microbasic instruction to disable sensor on Pulse input 1

`^PMOD 2 4` : Enable Sensor on Pulse input 2

`Setconfig(_PMOD, 2, 4)` : Microbasic instruction to enable sensor on Pulse input 2

The sensor information can then be accessed with the respective queries as discussed above (`?MGD`, `?MGT`, `?MGM`, `?FLW`).

Accessing Multiple Sensor Information Simultaneously

It is possible to have all sensors enabled at the same time by having their respective pulse input configured accordingly.

When more than one pulse input is configured that way, the sensor data is accessible using the `?MGD`, `?MGT`, `?MGM`, `?MGY` or `?FLW` queries as follows, where x is the pulse input number (1, 2, 3 etc.).

Reading Tape Detect

`?MGD x` or `GetValue(_MGD, x)`

Returns the Tape Detect state of Sensor at Pulse input x

Example:

`?MGD 2` : Returns the Tape Detect state of Sensor 2

Reading Marker Detect

`?MGM 2*(x-1)+1` or `GetValue(_MGM, 2*(x-1)+1)`

Returns the state of the Left Marker Detect state of Sensor at Pulse input x

`?MGM 2*(x-1)+2` or `GetValue(_MGM, 2*(x-1)+2)`

Returns the state of the Right Marker Detect state of Sensor at Pulse input x

Examples:

`?MGM 1` : Returns the Left Marker Detect state of Sensor at input 1

`?MGM 2` : Returns the Right Marker Detect state of Sensor at input 1

?MGM 3 : Returns the Left Marker Detect state of Sensor at input 2

?MGM 4 : Returns the Right Marker Detect state of Sensor at input 2

Reading Track Positions

?MGT $3*(x-1)+1$ or `GetValue(_MGT, 3*(x-1)+1)`

Returns the Left Track Position of Sensor at input x

?MGT $3*(x-1)+2$ or `GetValue(_MGT, 3*(x-1)+2)`

Returns the Right Track Position of Sensor at input x

?MGT $3*(x-1)+3$ or `GetValue(_MGT, 3*(x-1)+3)`

Returns the Active (Left or Right) Track Position of Sensor at input x

Examples:

?MGT 1 : Returns the Left Track Position of Sensor at input 1

?MGT 2 : Returns the Right Track Position of Sensor at input 1

?MGT 4 : Returns the Left Track Position of Sensor at input 2

?MGT 5 : Returns the Right Track Position of Sensor at input 2

?MGT 7 : Returns the Left Track Position of Sensor at input 3

Reading Flow Sensor Counters

?FLW $2*(z-1)+1$ or `GetValue(_FLW, 2*(z-1)+1)`

Returns the Counter of the X axis of Sensor at Pulse input z,

?FLW $2*(z-1)+2$ or `GetValue(_FLW, 2*(z-1)+2)`

Returns the Counter of the Y axis of Sensor at Pulse input z

Examples:

?FLW 1 : Returns the Counter of the X axis of Sensor at Pulse input 1

?FLW 2 : Returns the Counter of the X axis of Sensor at Pulse input 1

?FLW 3 : Returns the Counter of the Y axis of Sensor at Pulse input 2

?FLW 4 : Returns the Counter of the Y axis of Sensor at Pulse input 2

SECTION 6

Command Modes

This section discusses the controller's normal operation in all its supported operating modes.

Input Command Modes and Priorities

The controller will accept commands from one of the following sources

- Serial data (RS232, RS485, TCP, USB)
- Pulse (R/C radio, PWM, Frequency)
- Analog signal (0 to 5V)
- Spektrum Radio (on selected models)
- CAN Interface
- Microbasic Script

One, many or all command modes can be enabled at the same time. When multiple modes are enabled, the controller will select which mode to use based on a user selectable priority scheme and the hardcoded priorities concerning the CAN interface and the Microbasic script. Setting the priorities is done using the PC configuration utility.

This scheme uses a priority table containing three parameters and let you select which mode must be used in each priority order. During operation, the controller reads the first priority parameter and switches to that command mode. If that command mode is found to be active, that command is then used. If no valid command is detected, the controller switches to the mode defined in the next priority parameter. If no valid command is recognized in that mode, the controller then repeats the operation with the third priority parameter. If no valid command is recognized in that last mode, the controller applies a default command value that can be set by the user (typically 0).

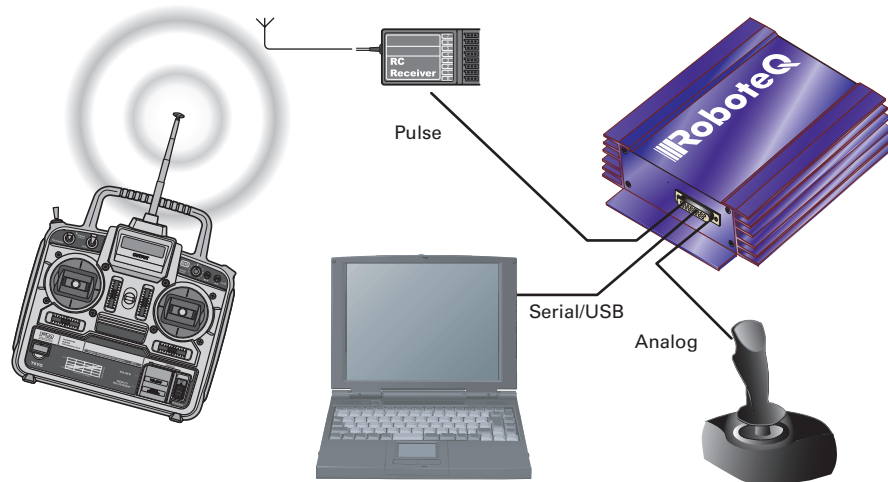

FIGURE 6-1. Controller's possible command modes

In the Serial mode, the mode is considered as active if commands

- !G - Go to Speed or to Relative Position
- !MS - Stop in all modes
- !S - Set Motor Speed
- !TC - Target Torque
- !GIQ - Set Torque Amps
- !GID - Set Flux Amps

arrive within the watchdog timeout period via the RS232, RS485, TCP or USB ports. The mode will be considered inactive, and the next lower priority level will be selected as soon as the watchdog timer expires. Note that disabling the watchdog will cause the serial mode to be always active after the first command is received, and the controller will never switch to a lower priority mode.

If the abovementioned commands are called from a script then the Script mode is enabled and if they are called from CAN network the CAN mode is enabled.

In the pulse mode, the mode is considered active if a valid pulse train is found and remains present.

In analog mode, the mode is considered active at all time, unless the Center at Start safety is enabled. In this case, the Analog mode will activate only after the joystick has been centered. The Keep within Min/Max safety mode will also cause the analog mode to become inactive, and thus enable the next lower priority mode, if the input is outside of a safe range.

The example in Figure 6-1 shows the controller connected to a microcomputer, a RC radio, and an analog joystick. If the priority registers are set as in the configuration below:

- 1- Serial
- 2- Pulse
- 3- Analog

then the active command at any given time is given in the table below.

TABLE 6-1. Priority resolution example

Microcomputer Sending commands	Valid Pulses Received	Analog joystick within safe Min/Max	Command mode selected
Yes	Don't care	Don't care	Serial
No	Yes	Don't care	RC mode
No	No	Yes	Analog mode
No	No	No	User selectable default value

Note that it is possible to set a priority level to "None". For example, the priority table

- 1 - Serial
- 2 - RC Pulse
- 3 - None

will only arbitrate and use Serial or RC Pulse commands.

USB vs Serial Communication Arbitration

Commands may arrive through the RS232, RS485, TCP or the USB port at the same time. They are executed as they arrive in a first come first served manner. Commands that are arriving via USB are replied on USB. Commands arriving via the RS232 are replied on the RS232 and so on. Redirection symbol for redirecting outputs to the other port exists (e.g. a command can be made to respond on USB even though it arrived on RS232).

CAN Commands Arbitration

On controllers fitted with a CAN interface, commands received via CAN are processed as they arrive regardless if any other mode, apart from Script mode, is active at the same time. CAN mode has the highest priority from all other modes apart from script mode.

Commands issued from MicroBasic scripts

When sending a Motor command from a MicroBasic script, it will be interpreted by the controller with higher priority than any other interface. If a serial command is received from the serial/USB port at the same time a command is sent from the script, the script command will prevail.

Important Warning

Script and CAN commands are also subject to the serial Watchdog timer. Script commands have the highest priority and CAN commands similar priority to serial commands. as shown below:

Priority	Mode	Configurable
1	Script Mode	No
2	CAN Mode	No
3, 4, 5	Serial Mode(RS232,RS485,TCP,USB)	Yes (see CPRI)
	Pulse Mode	
	Analog Mode	

Operating the Controller in RC mode

The controller can be directly connected to an R/C receiver. In this mode, the speed or position information is contained in pulses whose width varies proportionally with the joysticks' positions. The controller mode is compatible with all popular brands of RC transmitters.

The RC mode provides the simplest method for remotely controlling a robotic vehicle: little else is required other than connecting the controller to the RC receiver and powering it On.

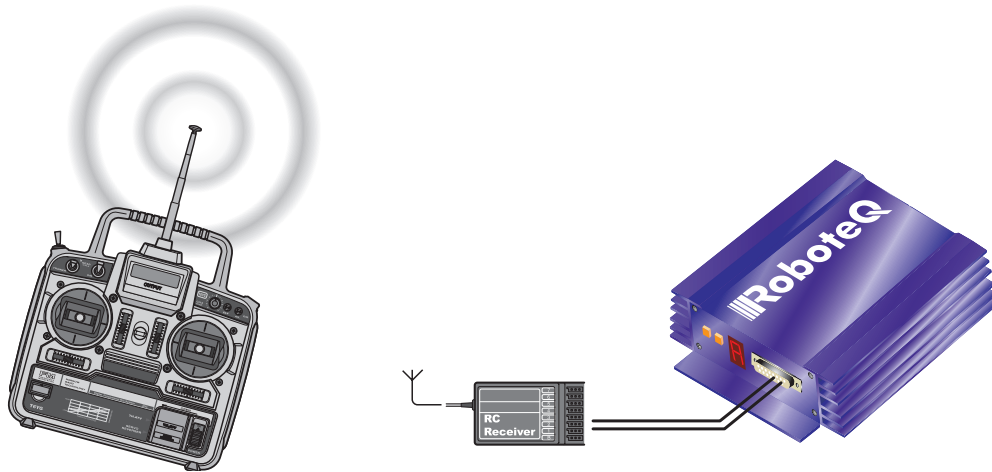

FIGURE 6-2. R/C radio control mode

The speed or position information is communicated to the controller by the width of a pulse from the RC receiver: a pulse width of 1.0 millisecond indicates the minimum joystick position and 2.0 milliseconds indicates the maximum joystick position. When the joystick is in the center position, the pulse should be 1.5ms.

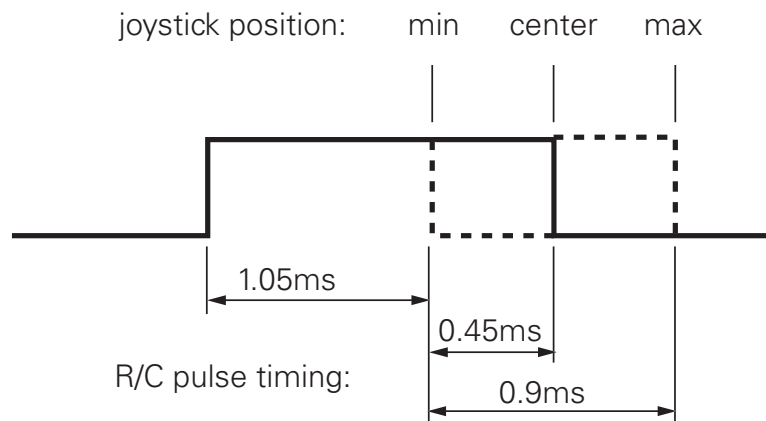

FIGURE 6-3. Joystick position vs. pulse duration default values

The controller has a very accurate pulse capture input and is capable of detecting changes in joystick position (and therefore pulse width) as small as 0.1%. This resolution is superior to the one usually found in most low cost RC transmitters. The controller will therefore be able to take advantage of the better precision and better

control available from a higher quality RC radio, although it will work fine with lesser expensive radios as well.

Input RC Channel Selection

The controllers feature several inputs that can be used for pulse capture. See product datasheet for an actual number of pulse input. Any RC input can be used as a command for any motor channels. The controller's factory default defines two channels for RC capture (one input on single channel products). Which channel and which pin on the input connector depends on the controller model and can be found in the controller's datasheet.

Changing the input assignment is done using the PC Configuration utility.

Input RC Channel Configuration

Internally, the measured pulse width is compared to the reference minimum, center, and maximum pulse width values. From this is generated a command number ranging from -1000 (when the joystick is in the min. position), to 0 (when the joystick is in the center position) to +1000 (when the joystick is in the max position). This number is then used to set the motor's desired speed or position that the controller will then attempt to reach.

For best results, reliability, and safety, the controller will also perform a series of corrections, adjustments and checks to the R/C commands, as described below.

Joystick Range Calibration

The Joystick min, max, and center position are adjustable. For best control accuracy, the controller can be calibrated to capture and use your radio's specific timing characteristics and store them into its internal Flash memory. This is done using a simple calibration procedure described page 60.

Deadband Insertion

The controller allows for a selectable amount of joystick movement to take place around the center position before activating the motors. See the full description of this feature at "Deadband Selection" page 61

Command Correction

The controller can also be set to translate the joystick motor commands so that the motor responds differently depending on whether the joystick is near the center or near the extremes. Five different exponential or logarithmic translation curves may be applied. Since this feature applies to the R/C, Analog and RS232 modes, it is described in detail in "Command Correction" page 62, in the General Operation section of the manual.

Reception Watchdog

Immediately after it is powered on, if in the R/C mode, the controller is ready to receive pulses from the RC radio.

If valid pulses are received on any of the enabled Pulse input channels, the controller will consider the RC Pulse mode as active. If no higher priority command is currently active (See "Input Command Modes and Priorities" page 73), the captured RC pulses will serve to activate the motors.

If no valid RC pulses reach the controller for more than 500ms, the controller no longer considers it is in the RC mode and a lower priority command type will be accepted if present.

Important Warning

Some receivers include their own supervision of the radio signals and will move their servo outputs to a safe position in case of signal loss. Using these types of receiver, the controller will always be receiving pulses even with the transmitter off.

Using Sensors with PWM Outputs for Commands

The controller's Pulse inputs can be used with various types of angular sensors that use contactless Hall technology and that output a PWM signal. These type of sensors are increasingly used inside joysticks and will perform much more reliably, and typically with higher precision than traditional potentiometers.

The pulse shape output from these devices varies widely from one sensor model to another and is typically different from this of RC radios:

- They have a higher repeat rate, up to a couple of kHz.
- The min and max pulse width can reach the full period of the pulse

Care must therefore be exercised when selecting a sensor. The controller will accommodate any pulsing sensor as long as the pulsing frequency does not exceed 250Hz. The sensor should not have pulses that become too narrow - or disappear altogether - at the extremes of their travel. Select sensors with a minimum pulse width of 10us or higher. Alternatively, limit mechanically the travel of the sensor to keep the minimum pulse width within the acceptable range.

A minimum of pulsing must always be present. Without it, the signal will be considered as invalid and lost.

Pulses from PWM sensors can be applied to any Pulse input on the controller's connector. Configure the input capture as Pulse or Duty Cycle.

A Pulse mode capture measures the On time of the pulse, regardless of the pulse period.

A Duty Cycle mode capture measures the On time of the pulse relative to the entire pulse period. This mode is typically more precise as it compensates for the frequency drifts of the PWM oscillator.

PWM signals are then processed exactly the same way as RC pulses. Refer to the RC pulse paragraphs above for reference.

Operating the Controller In Analog Mode

Analog Command is the simplest and most common method when the controller is used in a non-remote, human-operated system, such as Electric Vehicles.

Input Analog Channel Selection

The controller features 4 to 11 inputs, depending on the model type, that can be used for analog capture. Using different configuration parameters, any Analog input can be used as command for any motor channel. The controller's factory default defines two channels as Analog command inputs. Which channel and which pin on the input connector depends on the controller model and can be found in the controller's datasheet.

Changing the input assignment is done using the PC Configuration utility. See "Analog Inputs Configurations and Use" on page 59.

Input Analog Channel Configuration

An Analog input can be Enabled or Disabled. When enabled, it can be configured to capture absolute voltage or voltage relative to the 5V output that is present on the connector. See "Analog Inputs Configurations and Use" on page 59

Analog Range Calibration

If the joystick movement does not reach full 0V and 5V, and/or if the joystick center point does not exactly output 2.5V, the analog inputs can be calibrated to compensate for this. See "Min, Max and Center adjustment" on page 60 and "Deadband Selection" on page 61.

Using Digital Input for Inverting direction

Any digital input can be configured to change the motor direction when activated. See "Digital Inputs Configurations and Uses" on page 58. Inverting the direction has the same effect as instantly moving the command potentiometer to the same level the opposite direction. The motor will first return to 0 at the configured deceleration rate and go to the inverted speed using the configured acceleration rate.

Safe Start in Analog Mode

By default, the controller is configured so that in Analog command mode, no motor will start until all command joysticks are centered. The center position is the one where the input equals the configured Center voltage plus the deadband.

After that, the controller will respond to changes to the analog input. The safe start check is not performed again until power is turned off.

Protecting against Loss of Command Device

By default, the controller is protected against the accidental loss of connection to the command potentiometer. This is achieved by adding resistors in series with the potentiometer that reduces the range to a bit less than the full 0V to 5V swing. If one or more wires to the potentiometer are cut, the voltage will actually reach 0V and 5V and be considered a fault condition, if that protection is enabled. See "Connecting Potentiometers for Commands with Safety band guards" on page 49.

Safety Switches

Any Digital input can be used to add switch-activated protection features. For example, the motor(s) can be made to activate only if a key switch is turned On, and a passenger is present on the driver's seat. This is done using by configuring the controller's Digital inputs. See "Digital Inputs Configurations and Uses" page 58.

Monitoring and Telemetry in RC or Analog Modes

The controller can be fully monitored while it is operating in RC or Analog modes. If directly connected to a PC via RS232, RS485, TCP or USB, the controller will respond to operating queries (Amps, Volts, Temperature, Power Out, ...) without this having any effect on its response to Analog or RC commands. The PC Utility can therefore be used to visualize in real time all operating parameters as the controller runs. See "Run Tab" in Roborun+ Utility User Manual.

In case the controller is not connected via a bi-directional link, and can only send information one-way, typically to a remote host, the controller can be configured to output a user-selectable set of operating parameters, at a user selectable repeat rate. See "Query History Commands" on page 251

MicroBasic scripting can also be used to generate a periodic text string containing parameters to monitor.

Using the Controller with a Spektrum Satellite Receiver

Some controller models can be connected directly to a miniature Spektrum SP9545 satellite receiver. Using only 3 wires this interface will carry the information of up to 6 command joysticks with a resolution and precision that is significantly higher than traditional 1.5ms pulse signals.

The PC utility is used to map any of the 6 channels as a command for each motor. Binding the receiver to the transmitter is done using the %BIND maintenance command. See "Maintenance Commands" on page 254 for details on the binding procedure.

Using the Controller in Serial (USB/RS232/RS485/TCP) Mode

The serial mode allows full control over the controller's entire functionality. The controller will respond to a large set of commands. These are described in detail in "Serial (RS232/RS485/USB/TCP) Operation" on page 161.

SECTION 7

Motor Operating Features and Options

This section discusses the controller’s operating features and options relating to its motor outputs.

Power Output Circuit Operation

The controller’s power stage is composed of high-current MOSFET transistors that are rapidly pulsed on and off using Pulse Width Modulation (PWM) technique in order to deliver more or less power to the motors. The PWM ratio that is applied is the result of a computation that combines the user command and safety related corrections. In closed-loop operation, the command and feedback are processed together to produce the adjusted motor command. The diagram below gives a simplified representation of the controller’s operation.

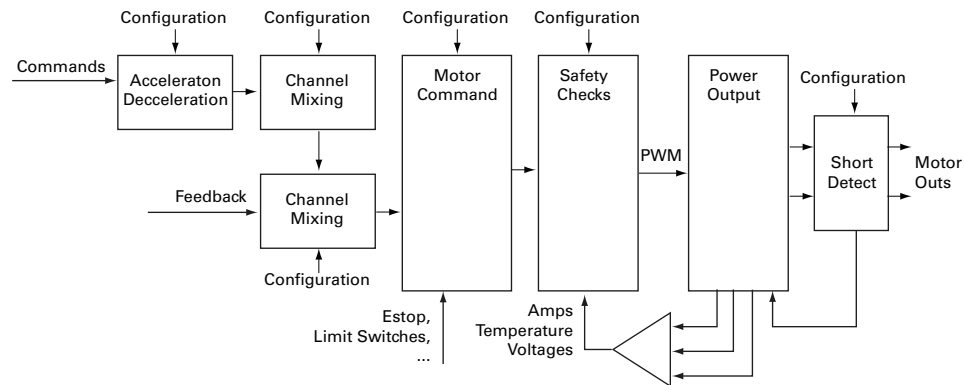

FIGURE 7-1. Simplified diagram of power output operation

Global Power Configuration Parameters

PWM Frequency

The power MOSFETs are switched at 16kHz by default. This frequency can be set to another value ranging from 10 kHz to 30 kHz. Increasing the frequency reduces efficiency due to switching losses. Lowering the frequency eventually creates audible noise and can be inefficient on low inductance motors.

Changing the PWM frequency typically results in no visible change in the motor operation and should be left untouched.

Overvoltage Protection

The controller includes a battery voltage monitoring circuit that will cause the output transistors to be turned Off if the main battery voltage rises above a preset Over Voltage threshold. The value of that threshold is set by default and may be adjusted by the user. The default value and settable range is given in the controller model datasheet.

This protection is designed to prevent the voltage created by the motors during regeneration to be "amplified" to unsafe levels by the switching circuit.

The controller will resume normal operation when the measured voltage drops below the Over Voltage threshold minus a user definable hysteresis voltage.

The controller can also be configured to trigger one of its Digital Outputs when an Over Voltage condition is detected. This Output can then be used to activate a Shunt load across the VMot and Ground wires to absorb the excess energy if it is caused by regeneration. This protection is particularly recommended for a situation where the controller is powered from a power supply instead of batteries.

Undervoltage Protection

In order to ensure that the power MOSFET transistors are switched properly, the controller monitors the internal preset power supply that is used by the MOSFET drivers. If the internal voltage drops below a safety level, the controller's output stage is turned Off. The rest of the controller's electronics, including the microcomputer, will remain operational as long as the power supply on VMot is above the minimum voltage specified in the product datasheet or if Power Control is above 7V.

Additionally, the output stage will be turned off when the main battery voltage on VMot drops below a user configurable level that is factory preset at 5V.

Temperature-Based Protection

The controller features active protection which automatically reduces power based on measured operating temperature. This capability ensures that the controller will be able to work safely with practically all motor types and will adjust itself automatically for the various load conditions.

When the measured temperature reaches 5°C below the Over temperature limit, the controller's maximum allowed power output begins to drop by 20% for every degree until the temperature reaches the Over temperature limit. Above this limit, the controller's power stage turns itself off completely. The same applies to MCU Temp at 90°C - 95°C degrees.

Note that the measured temperature is measured on the heat sink near the Power Transistors and will rise and fall faster than the outside surface.

The time it takes for the heat sink's temperature to rise depends on the current output, ambient temperature, and available air flow (natural or forced).

Short Circuit Protection

The controller includes a circuit that will detect very high current surges that are consistent with short circuits conditions. When such a condition occurs, the power transistor for the related motor channel is cut off within a few microseconds. Conduction is restored at 1ms intervals. If the short circuit is detected again for up to a quarter of a second, it is considered as a permanent condition and the controller enters a Safety Stop condition, meaning that it will remain off until the command is brought back to 0.

The short circuit detection can be configured with the PC utility to have one of three sensitivity levels: quick, medium, and slow.

The protection is very effective but has a few restrictions:

Only shorts between two motor outputs of the same channel are detected. Shorts between a motor wire and VMot are also detected. Shorts between motor output and Ground are not detected.

Wire inductance causes current to rise slowly relative to the PWM On/Off times. Short circuit will typically not be detected at low PWM ratios, which can cause significant heat to eventually accumulate in the wires, load, and the controller, even though the controller will typically not suffer direct damage. Increasing the short circuit sensitivity will lower the PWM ratio at which a short circuit is detected.

Since the controller can handle very large current during its normal operation, Only direct short circuits between wires will cause a sufficiently high current for the detection to work. Short circuits inside motors or over long motor wires may go undetected.

A simplified short circuit protection logic is implemented on some controller models. Check with controller datasheet for details.

Mixed Mode Select

Mixed mode is available as a configuration option in dual channel controllers to create tank-like steering when one motor is used on each side of the robot: Channel 1 is used for moving the robot in the forward or reverse direction. Channel 2 is used for steering and will change the balance of power on each side to cause the robot to turn. Figure 7-2 below illustrates how the mixed mode motor arrangement.

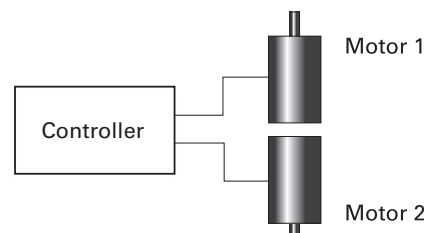

FIGURE 7-2. Effect of commands to motor examples in mixed mode

The controller supports 3 mixing algorithms with different driving characteristics. The table below shows how each motor output responds to the two commands in each of these modes.

TABLE 7-1. Mixing Mode characteristics

Input		Mode 1		Mode 2		Mode 3	
Throttle	Steering	M1	M2	M1	M2	M1	M2
0	0	0	0	0	0	0	0
0	300	300	-300	300	-300	300	-300
0	600	600	-600	600	-600	600	-600
0	1000	1000	-1000	1000	-1000	1000	-1000
0	-300	-300	300	-300	300	-300	300
0	-600	-600	600	-300	300	-600	600
0	-1000	-1000	1000	-1000	1000	-1000	1000
300	300	600	0	600	0	522	90
300	600	900	-300	900	-300	762	-120
300	1000	1000	-700	1000	-1000	1000	-400
300	-300	0	600	0	600	90	522
300	-600	-300	900	-300	900	-120	762
300	-1000	-700	1000	-1000	1000	-400	1000
600	300	900	300	900	300	708	480
600	600	1000	0	1000	-200	888	360
600	1000	1000	-400	1000	-1000	1000	200
600	-300	300	900	300	900	480	708
600	-600	0	1000	-200	1000	360	888
600	-1000	-400	1000	-1000	1000	200	1000
1000	300	1000	700	1000	400	900	1000
1000	600	1000	400	1000	-200	1000	1000
1000	1000	1000	0	1000	-1000	1000	1000
1000	-300	700	1000	400	1000	1000	900
1000	-600	400	1000	-200	1000	1000	1000
1000	-1000	0	1000	-1000	1000	1000	1000

Motor Channel Parameters

User Selected Current Limit Settings

The controller has current sensors at each of its output stages. Every 1 ms, this current is measured and a correction to the output power level is applied if higher than the user preset value.

The current limit may be set using the supplied PC utility. The maximum limit is dependent on the controller model and can be found on the product datasheet.

The limitation is performed on the Motor current and not on the Battery current. See “Battery Current vs. Motor Current” on page 28 for a discussion of the differences.

Selectable Amps Threshold Triggering

The controller can be configured to detect when the Amp on a motor channel exceeds a user-defined threshold value and trigger an action if this condition persists for more than a preset amount of time.

The list of actions that may be triggered is shown in the table below.

TABLE 7-2. Possible Action List when Amps threshold is exceeded

Action	Applicable Channel	Description
No Action	-	Input causes no action
Safety Stop	Selectable	Stops the selected motor(s) channel until command is moved back to 0 or command direction is reversed
Emergency stop	All	Stops the controller entirely until controller is powered down, or a special command is received via the serial port

This feature is very different from amps limiting. Typical uses for it are for stall detection or “soft limit switches.” When, for example, a motor reaches an end and enters stall condition, the current will rise, and that current increase can be detected and the motor be made to stop until the direction is reversed.

Programmable Acceleration & Deceleration

When changing speed command, the controller will go from the present speed to the desired one at a user selectable acceleration. This feature is necessary in order to minimize the surge current and mechanical stress during abrupt speed changes.

This parameter can be changed by using the PC utility. Acceleration can be different for each motor. A different value can also be set for the acceleration and for the deceleration. The acceleration value is entered in RPMs per second. In open loop installation, where speed is not actually measured, the acceleration value is relative to the Max RPM parameter. For example, if the Max RPM is set to 1000 (default value) and acceleration to 2000, this means that the controller will go from 0 to 100% power in 0.5 seconds. In closed loop Torque Mode the Acceleration and Deceleration values are entered in milliAmps per second. In case of Safety Stop the motor will ramp down based on the Fault Deceleration configuration value.

In order to by-pass the ramping process, either the acceleration or the deceleration values need to be set to 0.

Important Warning

Depending on the load’s weight and inertia, a quick or no acceleration can cause considerable current surges from the batteries into the motor. A quick or no deceleration will cause an equally large, or possibly larger, regeneration current surge. Always experiment with the lowest acceleration value first and settle for the slowest acceptable value.

Furthermore, by by-passing command ramp the controller cannot protect itself from high currents.

Forward and Reverse Power Adjustment Gain

This parameter lets you select the scaling factor for the power output as a percentage value. This feature is used to connect motors with a voltage rating that is less than the battery voltage. For example, using a factor of 50% it is possible to connect a 12V motor onto a 24V system, in which case the motor will never see more than 12V at its input even when the maximum power is applied.

Selecting the Motor Control Modes

For each motor, the controller supports multiple motion control modes. The controller's factory default mode is Open Loop Speed control for each motor. The mode can be changed using the Roborun PC utility.

Open Loop Speed Control

In this mode, the controller delivers an amount of power proportional to the command information. The actual motor speed is not measured. Therefore the motor will slow down if there is a change in load as when encountering an obstacle and change in slope. This mode is adequate for most applications where the operator maintains visual contact with the robot.

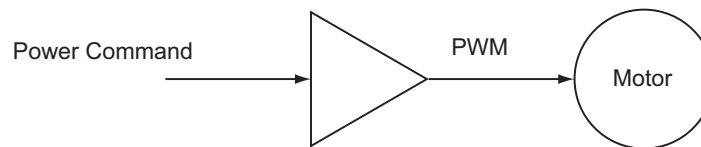

FIGURE 7-3: Open loop mode

Closed Loop Speed Control

In this mode, illustrated in Figure 7-4, an optical encoder (typical) or an analog tachometer is used to measure the actual motor speed. If the speed changes because of changes in load, the controller automatically compensates the power output. This mode is preferred in precision motor control and autonomous robotic applications. Details on how to wire the tachometer can be found in "Connecting Tachometer to Analog Inputs" on page 48. Closed Loop Speed control operation is described in "Closed Loop Speed Mode" on page 133. On brushless motors, speed may be sensed directly from the motor's Hall or other internal Sensors and closed loop operation is possible without additional hardware.

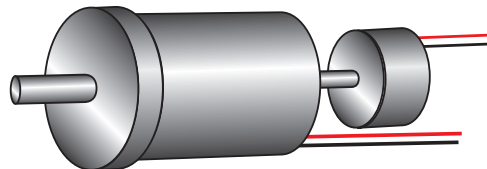

FIGURE 7-4. Motor with tachometer or Encoder for Closed Loop Speed operation

Closed Loop Speed Position Control

In this mode, the controller computes the position at which the motor must be at every 1ms. Then a position loop compares that expected position with the current position and applies the necessary power level in order for the motor to reach that position. This mode is especially effective for accurate control at very slow speeds. Details on this mode can be found in **Closed Loop Speed and Speed-Position Modes** on page 133.

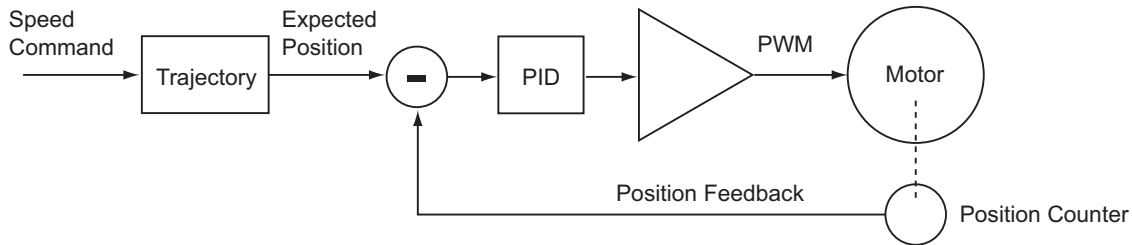

FIGURE 7-5: Closed Loop Speed Position mode

Closed Loop Position Relative Control

In this mode, illustrated in Figure 7-6, the axle of a geared down motor is typically coupled to a position sensor that is used to compare the angular position of the axle versus a desired position. The motor will move following a controlled acceleration up to a user defined velocity and decelerate to smoothly reach the desired destination. This feature of the controller makes it possible to build ultra-high torque “jumbo servos” that can be used to drive steering columns, robotic arms, life-size models and other heavy loads. Details on how to wire the position sensing potentiometers and operating in this mode can be found in “Closed Loop Relative and Tracking Position Modes” on page 141.

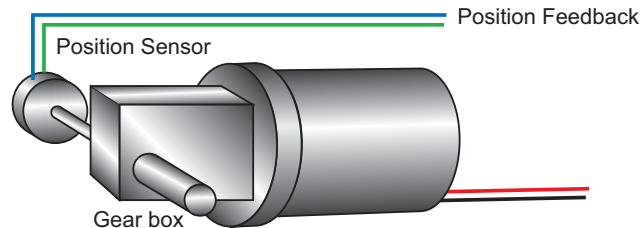

FIGURE 7-6. Motor with potentiometer assembly for position operation

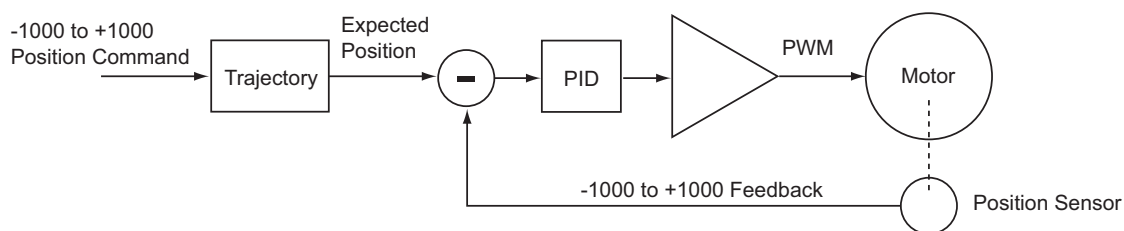

FIGURE 7-7. Closed Loop Position Relative mode

Closed Loop Count Position

In this mode, an encoder is attached to the motor as for the Speed Mode of Figure 7-8. Then, the controller can be instructed to move the motor to a specific number of counts, using a user-defined acceleration, velocity, and deceleration profile. Details on how to configure and use this mode can be found in "Closed Loop Count Position Mode" on page 151. On brushless motors, the hall sensors can be also be used for position measurement.

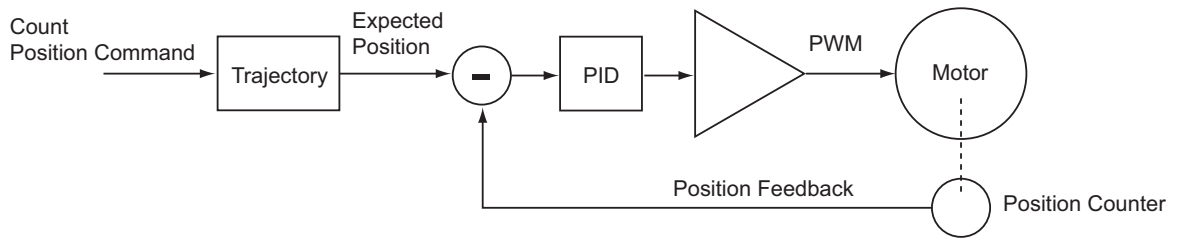

FIGURE 7-8: Closed Loop Count Position mode

Closed Loop Position Tracking

This mode uses the same feedback sensor mount as this of Figure 7-9. In this mode, the motor will be moved until the final position measured by the feedback sensor matches the command. The motor will move as fast as it possibly can, using maximum physical acceleration. This mode is best for systems where the motor can be expected to move as fast as the command changes. Details on this operating mode can be found in "Closed Loop Relative and Tracking Position Modes" on page 141.

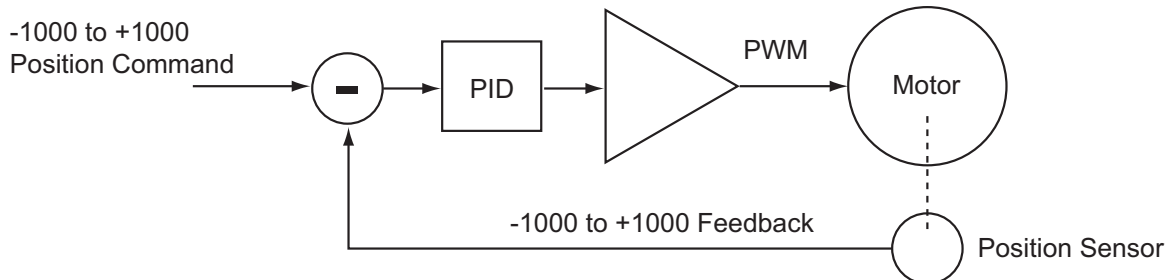

FIGURE 7-9: Closed Loop Position Tracking mode

Torque Mode

In this closed loop mode, the motor is driven in a manner that it produces a desired amount of torque regardless of speed. This is achieved by using the motor current as of the feedback. Torque mode does not require any specific wiring. The detail on this operating mode can be found in "Closed Loop Torque Mode" on page 157.

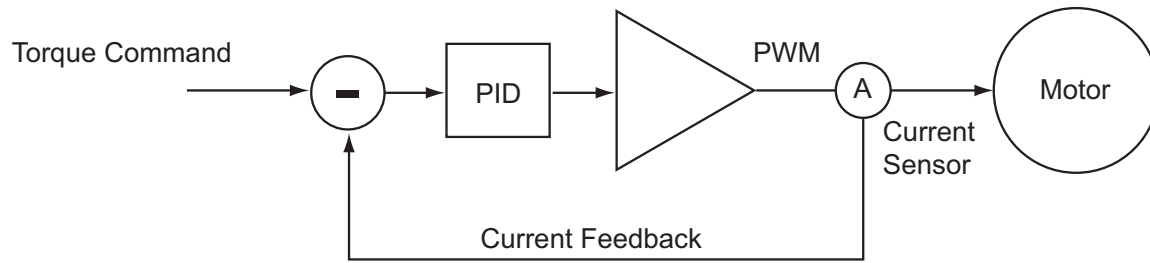

FIGURE 7-10: Closed Loop Torque mode

SECTION 8

Brushless Motor Connections and Operation

This section addresses installation and operating issues specific to brushless motors. It is applicable only to brushless motor controller models.

Important Warning

This Manual refers to Firmware 2.x of Roboteq Motor Controllers. Many of the described features are either not available or do not work the same way (PID gains in particular) than in Firmware 1.x or prior. Refer to Manual v1.8 for earlier Firmware.

Introduction to Brushless Motors

Brushless motors, or more accurately Brushless DC Permanent Magnet Synchronous motors (since there are other types of motors without brushes) contain permanent magnets and electromagnets. The electromagnets are arranged in groups of three and are powered in sequence in order to create a rotating field that drives the permanent magnets. The electromagnets are located on the non-rotating part of the motor, which is normally in the motor casing for traditional motors, in which case the permanent magnets are on the rotor that is around the motor shaft. On hub motors, such as those found on electric bikes, scooters and some other electric vehicles, the electromagnets are on the fixed center part of the motor and the permanent magnets on the rotating outer part.

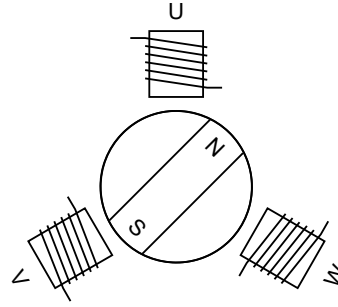

FIGURE 8-1. Permanent Magnet Synchronous Motor construction

As the name implies, Brushless motors differ from traditional DC motors in that they do not use brushes for commutating the electromagnets. Instead, it is up to the motor controller to apply, in sequence, current to each of the 3 motor windings in order to cause the rotor to spin. There are fundamentally two methods of generating the rotating magnetic field in the motor's winding:

- Trapezoidal Commutation
- Sinusoidal Commutation

Within each commutation method is then a method for detecting the actual position of the rotor in order to synchronize the generated rotating field. These are:

- Hall sensors
- Encoders (Absolute or relative)
- Sensorless (Trapezoidal only)

All Roboteq brushless controllers support Trapezoidal with Hall sensor feedback. Sinusoidal and alternative rotor detection techniques are available on selected models. Refer to the controller's datasheet to determine which modes are supported.

Number of Poles

One of the key characteristics of a brushless motor is the number of poles of permanent magnets pairs it contains. A full 3-phase cycling of motor's electromagnets will cause the rotor to move to the next permanent magnet pole. A full 3-phase cycle is known as electrical turn which will be different from the physical (mechanical) turn of the shaft if the motor number of pole pairs is greater than one: increasing the number of pole pairs will cause the motor to rotate more slowly for a given rate of change on the winding's phases.

Roboteq controllers use the number of motor pole pairs to measure the number of turns a motor has made as well as motor speed.

Determining the Number of Poles

The number of pole pairs on a particular motor is usually found in the motor's specification sheet. The number of pole pairs can also be measured by applying a low DC current (around 1A) between any two of the three motor phase wires and then counting the number of cogs you feel when rotating the motor by hand for a full turn. It can also be determined by rotating the motor shaft by hand a full turn. Then take the number of counts reported by the hall counter in the Roborun PC utility, and divide it by 6.

$$\text{\#Pole Pairs} = \text{Hall Counts per turn} / 6$$

The number must be entered using the Number of Pole Pairs menus in the in the Roborun PC utility..

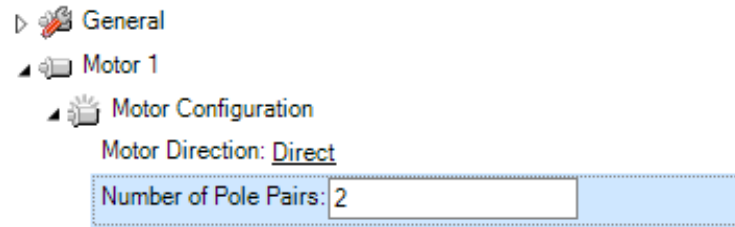

Or by sending the configuration command:

^BPOL channel nn

See “BPOL” in the command reference section for details. This parameter is not needed for basic trapezoidal motor operation with Hall Sensor feedback and can be left at its default value. It is needed if accurate speed reporting is required or to operate in Closed Loop Speed or Position modes . The number of pole pairs is a critical configuration in sinusoidal mode.

Entering a negative number of pole pairs will reverse the measured speed and the count direction. It is useful when operating the motor in closed loop speed mode and if otherwise a negative speed is measured when the motor is moved in the positive direction.

Trapezoidal Switching

In trapezoidal switching, the controller applies current to two of the 3 motor wires, in turn and in alternating direction. A total of 6 combinations of current flow are possible, resulting in the rotor getting a changing magnetic field every 60 degrees of electrical rotation. The controller must therefore know where the rotor is in relation to the electromagnets so that current can be applied to the correct winding at any given point in time. The simplest and most reliable method is to use three Hall sensors inside the motor. The diagram below shows the direction of the current in each of the motor’s windings depending on the state of the 3 hall sensors.

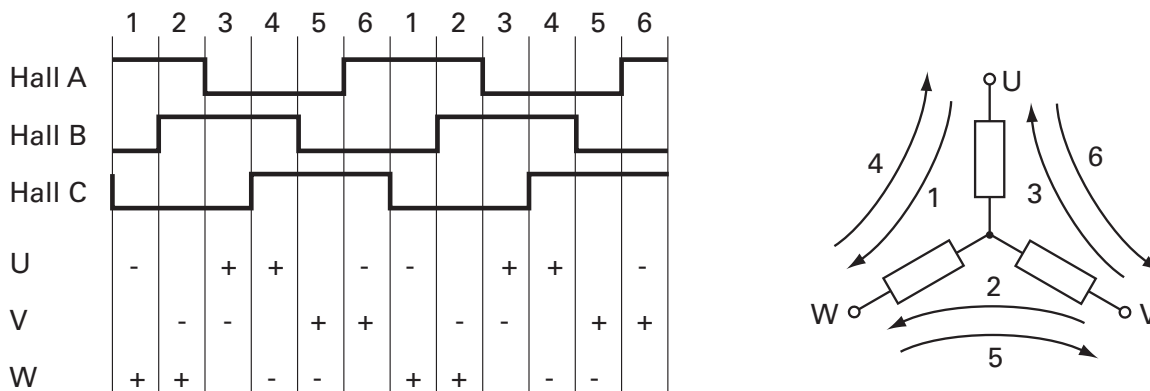

FIGURE 8-2. Hall sensors sequence

Hall Sensor Wiring

Hall sensors connection requires 5 wires on the motor:

- Ground
- Sensor A Output
- Sensor B Output
- Sensor C Output
- +5V power supply

Sensor outputs are generally Open Collector, meaning that they require a pull up resistor in order to create the logic level 1. Pull up resistor of 4.7K ohm to +5V are incorporated inside all controllers. Additionally, 1nF capacitors to ground are present at the controller's input in order to remove high frequency spikes which may be induced by the switching at the motor wires.

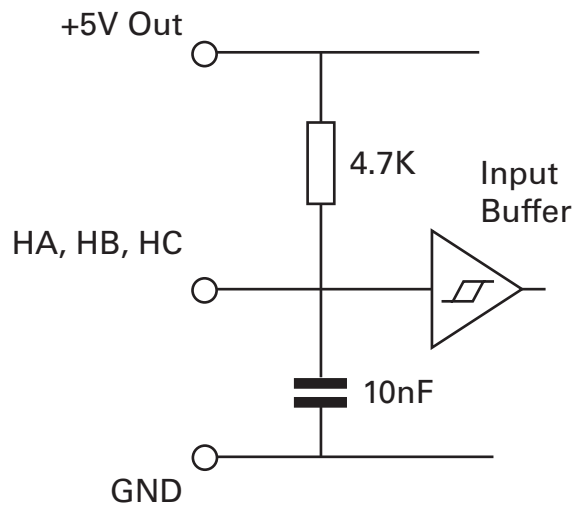

FIGURE 8-3. Hall sensor inputs equivalent circuit

Both 120 degrees and 60 degrees Hall sensors spacing, are supported (see "HPO" in the command reference section). Hall sensors can typically be powered over a wide voltage range. The controller supplies 5V for powering the Hall sensors.

Important Notice

120 degrees Hall sensor spacing is by far the most common. Use 60 degrees only if that is specified in the motor's documentation or label.

Unless specified otherwise in the datasheet, Hall sensor connection to the controller is done using Molex Microfit 3.0 connectors. These high quality connectors provide a reliable connection and include a lock tab for secure operation. The connector pin-out is shown in the controller model's datasheet.

In several controller models, the Hall inputs can be alternatively mapped to digital inputs on the I/O connector. This makes it possible to use the hall sensors for rotor commutation, and SSI sensors for other purposes at the same time (see "MLX" in the command ref-

erence section). Note that in the case where digital inputs are configured as Hall inputs, pull-up resistor from the input pin to the +5V must be added externally. Use 4.7K resistors wired as shown in Figure 8.3.

Important Warning

Keep the Hall sensor wires away from the motor wires. High power PWM switching on the motor leads will induce spikes on the Hall sensor wires if located too close. On hub motors where the Hall sensor wires are inside the same cable as the motor power wires, separate the two sets of wires the nearest from the motor as possible.

Important Notice

Make sure that the motor sensors have a digital output with the signal either at 0 or at 1. Sensors that output are gradually changing are typically analog signals will cause the motor to run imperfectly.

Hall Sensor Verification

Hall Sensor miswiring is a very common cause when the motor is not running. You can send the following query to verify that the hall sensors are seen by the controller:

```
?HS [channel]
```

The reply is one or two numbers, depending on the number of channels, of values between 0 and 7 with each bit representing the state of each of the HA, HB and HC sensors.

Turn the motor slowly by hand while sending frequent ?HS queries. Verify that all valid combinations appear at one time or the other and that none of the invalid combination ever show.

For 120 degrees spaced sensors, 1-2-3-4-5-6 are valid combinations, while 0 and 7 are invalid combinations. For 60 degrees spaced Hall sensors, 0-1-3-4-6-7 are valid combinations, while 2 and 5 are invalid combinations.

Note that HS query does not work on the first generation HBL and VBL family of products.

Hall Sensor Wiring Order

The order of the Hall sensors and these of the motor connections must match in order for the motor to spin. Unfortunately, there is no standard naming and ordering convention for brushless motors.

The Hall Sensor and Motor Phases naming convention used in Roboteq controllers is A, B and C for the sensors and U, V and W for the motor phases. When rotating the motor shaft clockwise by hand, the controller expects the sensor A to be a mirror of the voltage generated between wires U and W, sensor B between V and U, sensor C between W and

V. See figure 8-4. The sine wave voltage will be inverted when turning the motor in the opposite direction.

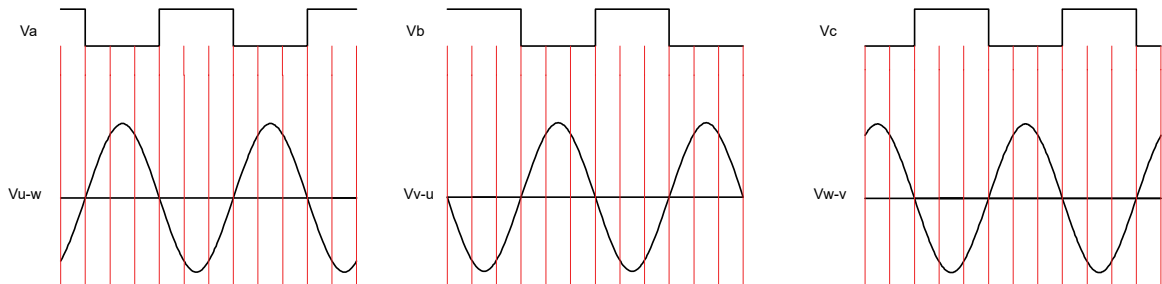

FIGURE 8-4. Relation between hall sensor and U V W windings

Determining the Wiring Order Empirically

While probing with an oscilloscope gives the definite order, a simpler and quicker way is to find the correct combination by trial and error. To do this, you can either connect the motor wires permanently and then try different combination of Hall sensor wiring, or you can connect the Hall sensors permanently and try different combinations of motor wiring. There is a total of 6 possible combinations of wiring three sensors on three controller inputs. There are also 6 possible combinations of wiring three motor wires on three controller outputs. Only one of the 6 combinations will work correctly and smoothly while allowing the controller to drive the motor in both directions.

Alternatively, instead of swapping Hall sensors or motor phases, you can use the "Hall Sensor Map" configuration from the PC Utility menu (see "HSM" in the command reference section), or from the following console command:

```
^HSM ch nn
```

Try each of the 6 available values of HSM (0-5) and retain the one that will make the motor spin in both directions while drawing the same low current.

When testing a combination, apply a low amount of power (5 to 10%). Applying too high power may trigger the stall protection. Once a combination that make the motor spin is found, increase the power level and verify that rotation is smooth, at very slow speed and at high speed and in both directions.

Important Notice

Beware that while only one combination is valid, there may be other combinations that will cause the motor to spin. When the motor spins with the wrong wiring combination, it will do so very inefficiently. Make sure that the motor spins equally smoothly in both directions. Try all 6 combinations and select the best.

Important Notice

It is not possible to change the motor direction by changing the Hall/Phase order. If the motor is not turning in the desired direction, chose "Inverted" in the "Motor Direction" configuration menu in the PC Utility.

Hall Sensor Alignment

It is very important that the hall sensors be precisely aligned vs the electromagnets inside the motor so that commutation be done exactly at the right time. Bad alignment will cause the motor to run inefficiently.

A first, and generally reliable clue that Hall Sensors are not properly aligned is to run the motor in the forward and then reverse direction while in Open Loop. Verify that for a given command level in open loop, the motor reaches the identical speed and consumes the same amount of current.

Another simple verification method is to use an oscilloscope to view the shape of the phase voltage. While the motor is running, place a probe between ground and any of the motor phases. Verify that the voltage looks like the shape on the figure 8-5. Look for symmetrical ramps on the left and right. An imbalance in the ramps indicates that the commutation happens at the wrong time because of bad Hall Sensor position.

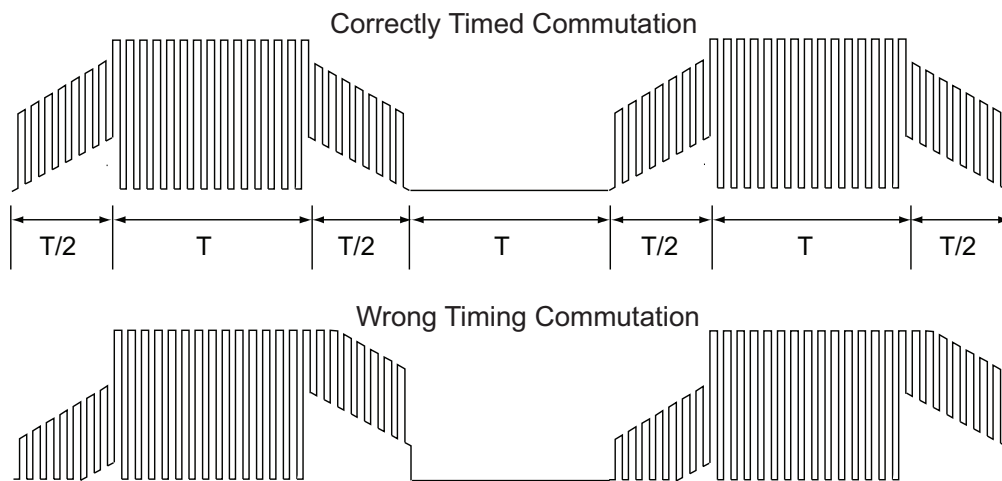

FIGURE 8-5. Ground to Phase voltage waveform on motor with correct and wrong commutations

The most precise evaluation of the Hall Sensors alignment is done using an oscilloscope and the circuit described in figure 8.6. Compare the shape of the Hall Sensor signal to this of the voltage that is generated on the motor phases as the shaft is rotated by an external force. Verify that the zero-crossing of the phase voltages is occurring at exactly the same time as the Hall Sensor transitions, as shown in figure 8-4.

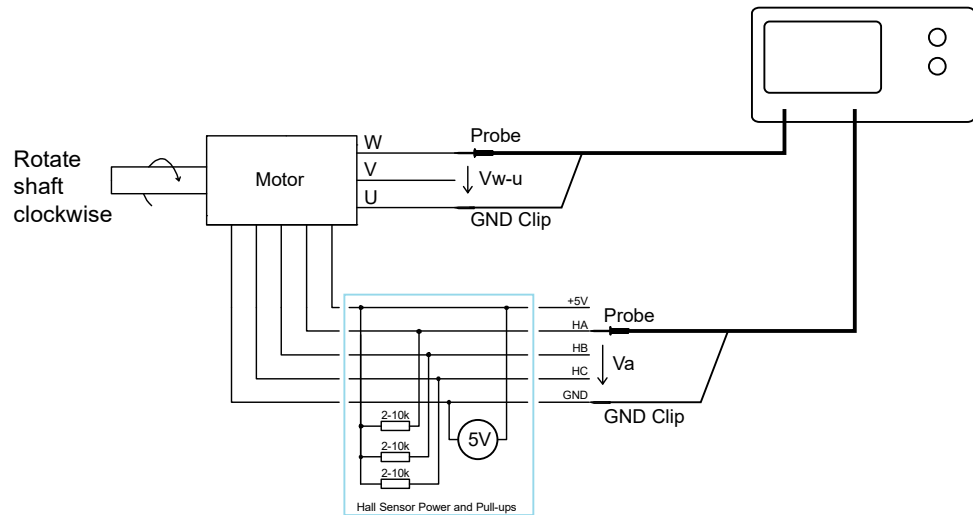

FIGURE 8-6. Use an oscilloscope and the circuit in figure to place the probes and generate these signals

Important Warning

Hall Sensor misalignment cannot be corrected by the controller. Contact the motor manufacturer for remedy.

Sinusoidal Commutation

In sinusoidal commutation, all three wires are permanently energized with a sinusoidal current that is 120 degrees apart on each phase as shown in figure 8-7.

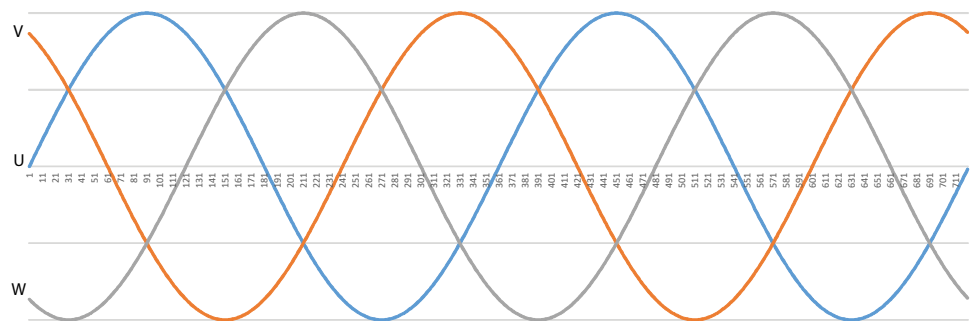

FIGURE 8-7. Three phase current creating a rotating magnetic field

At its most basic operation, the controller measures the rotor's angular position, adds or subtracts 90 degrees depending on the desired rotation direction, and applies the result to the 3-phase PWM generator.

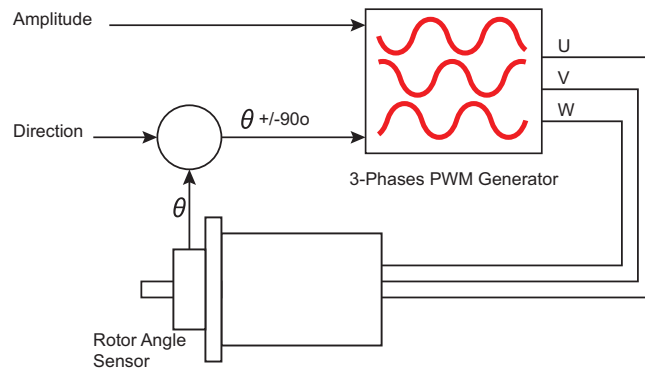

FIGURE 8-8. Simplified 3-phase sinusoidal model

As the motor turns, the phase on each wire is changed in order for the magnetic field to always be perpendicular, and therefore create the maximum radial force to the rotor.

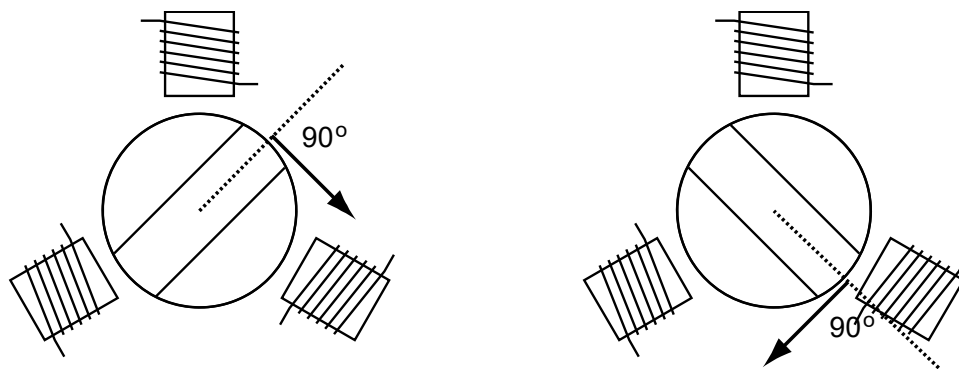

FIGURE 8-8. Magnetic field perpendicular to rotor magnets

The principle benefit of sinusoidal commutation is the quiet, rumble-free, motor operation resulting from the smoothly rotating and always aligned magnetic field.

However, sinusoidal commutation is more complex to configure, calibrate, tune and operate. For best and fastest results it is recommended that you follow these step rigorously:

- 1- Configure the Controller for Sinusoidal Commutation (page 100)
- 2- Select and Configure a Supported Angle Sensors (page 102)
- 4- Prepare for Automatic Sensor Setup (page 107)
- 5- Run the Automatic Sensor Setup (page 110)
- 6- Set, Test and Troubleshoot FOC-Field Oriented Control

Configuring the Controller for Sinusoidal Commutation

Sinusoidal mode is selected via the Switching Mode configuration menu in the Roborun PC utility..

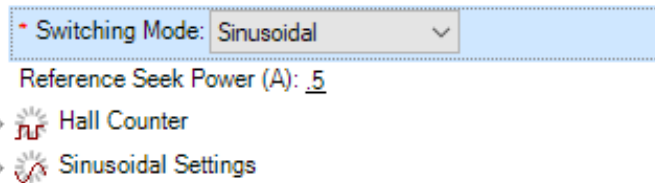

Or by sending the configuration command:

^BMOD channel 1

Configuring the Number of Motor Pole Pairs

The number of Motor Pole Pairs is a critical parameter for sinusoidal combination. A full 3-phase cycling of motor’s electromagnets will cause the rotor to move to the next permanent magnet pole. A full 3-phase cycle is known as electrical turn which will be different from the physical (mechanical) turn of the shaft if the motor number of pole pairs is greater than one. The figure below show the relationship between mechanical degree and electrical degree in the case of a two pole pairs motor.

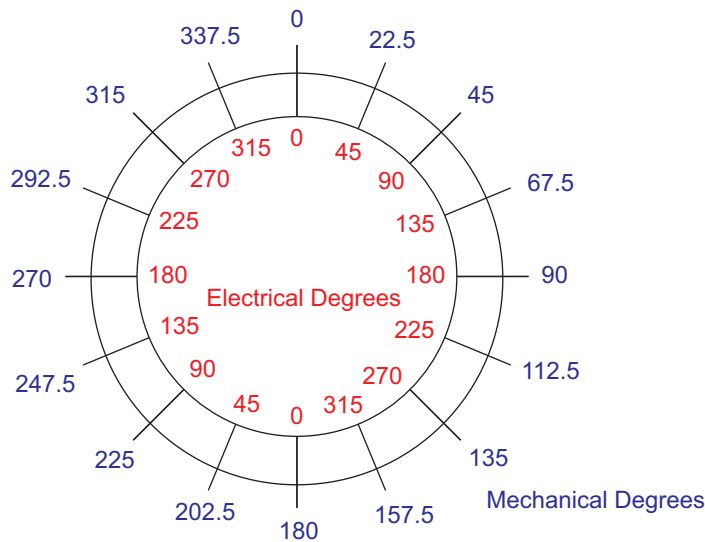
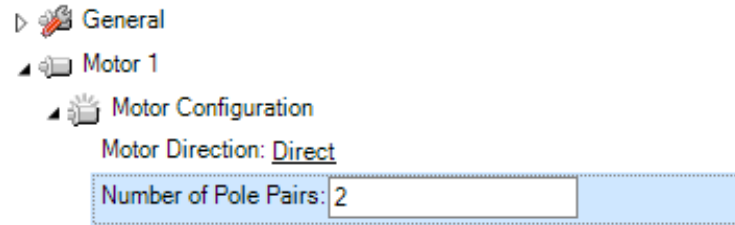

FIGURE 8-9. Mechanical vs electrical degrees

See “Determining the Number of Poles” on page 92 for details on how to determine the number of pole pairs and configuring the controllers.

The number must be entered using the Number of Pole Pairs menus in the in the Roborun PC utility..



Or by sending the configuration command:

^BPOL channel nn

Entering a negative number of pole pairs will reverse the measured speed and the count direction. It is useful when operating the motor in closed loop speed mode and if otherwise a negative speed is measured when the motor is moved in the positive direction.

Configuring Number of Sensor Poles

Single pole absolute sensors like Resolvers, sin/cos and SSI encoders typically return an angular value that is equal to the mechanical angle. The controller then converts the measured angle into the electrical angle for its internal operation, using the formula:

$$\text{Electrical Angle} = (\text{Sensor Angle} * \text{Number of Poles}) \text{ modulo } 360$$

When used on motors with a high number of pole pairs, single pole sensors will measure the electrical angle with degrading resolution as the number of motor poles is higher. For example, a single pole sensor with 10 resolution on a 10 pole motor will produce an electric angle evaluations with 10 resolution, which will result in less than optimal operation.

To resolve this problem, some absolute sensors are available in multiple pole versions. In that case, the sensor will outputs a 0-360 angle value multiple times during a full turn. Note that the controller will not work if the number of sensor poles is higher than the number of motor poles.

Enter the number of Sensor Poles in the SinCos/SSI Sensor Poles configuration menu in the Roborun PC utility.

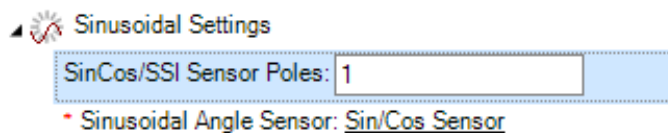

Or by sending the configuration command:

^SPOL ch poles

You can determine or verify the number of sensor poles by following these steps:

- 1 Set Motor Poles to 1
- 2 Launch the Calibration/Setup
- 3 Make one full rotation of the motor shaft by hand and monitor the Angle value reported in Roborun Utility.

- 4 Check how many times the Angle range (0-511) rolls over. This gives the number of sensor poles.
- 5 Restore the correct values of motor and sensor poles
- 6 Launch the Calibration/Setup again

Important Notice

The number of motor poles and sensor poles are very important configuration parameters in sinusoidal mode. Using the wrong values will produce erratic behavior and possibly damage.

Selecting and Configuring Supported Angle Sensors

In order for the proper voltage and phase to be applied to each of the 3 motor wires, the rotor angular position must be known with precision at all times. Roboteq controllers support several sensors for achieving this.

Then select the method for capturing the rotor angle of the rotor as the motor spins. This is done using the Sinusoidal Angle Sensor configuration menu in the utility.

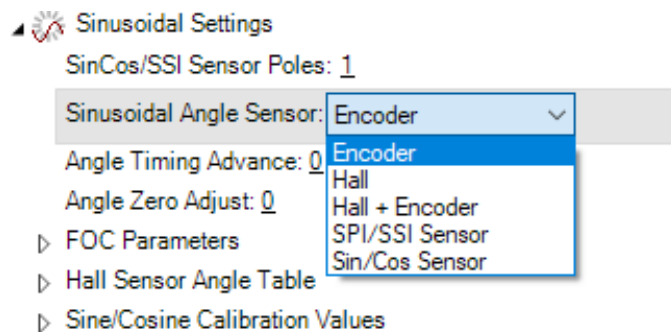

Or by sending the configuration command:

^BFBK ch mode

Where mode:

- 0: Encoder
- 1: Hall
- 2: Hall+Encoder
- 3: SSI sensor
- 4: Sin/Cos Sensor
- 5: Resolver

Each mode requires a various amount of additional setup and/or calibration as described in the following sections.

Incremental Encoder-Only

A quadrature encoder can be used to determine the rotor position. Enter the Encoder PPR using the PC Utility.

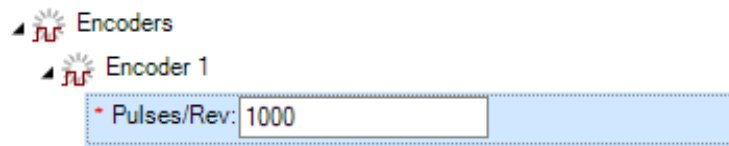

Or by sending the configuration command:

```
^EPPR channel nn
```

Optimally, the encoder should have a PPR that is at least 128 x the number of pole pairs. For example a motor with 4 pole pairs should have a 128 x 4 = 512 Pulse per revolution. This will result in 2048 counts for a full turn of the rotor, and therefore the electrical angle to be measured with $360 / 2048 * 4 = 0.7$ degrees, resulting in a very smooth changing sinusoidal drive to the motor. A significantly lower resolution encoder will result in a stepping sinusoid. A higher resolution encoder will not improve the waveform.

Since encoders do not give an absolute position, a reference search sequence is performed automatically by the controller at every power up or when the controller switches from a different mode to sinusoidal mode with encoder feedback

The search can also be forced manually by pressing the Sensor Setup button on the Diagnostic tab of the PC utility, or by sending the following maintenance command from the console or the serial/USB port

```
%CLMOD 2 (for channel 1) or
%CLMOD 3 (for channel 2).
```

Before trusting that reference search will be successful at every power up, try repeatedly to send the sensor tuning (%CLMOD) command under real-life load conditions. After reference search is completed, verify that the motor turns with the same efficiency in the forward and reverse direction.

Proper operation of the encoder can be verified by viewing the counter with the query:

```
?C [channel]
```

And verifying that it increments by the Encoder's CPR (counts per revolution, or PPR *4) when making a full turn, and returns to its original value after a full turn in the reverse direction.

Hall-Only

In this mode, the Hall sensors are used to determine the angular position of the rotor. Since transitions of the Hall pattern occur at every 60 degrees only, the controller will estimate the current angle by interpolating in between two transition based on the current motor speed. This technique works well as long as speed is stable and changes are

relatively slow. It also requires that the magnets and sensors are positioned with precision inside the motor, which is not always the case in low cost motors. Compared to Trapezoidal mode, this mode will result in quieter motor operation because of the sinusoidal commutation.

Proper operation of the Hall sensors can be verified by checking that the hall counter changes by $6 * \text{the number of poles}$ over a full mechanical turn in the PC Utility or by using the query:

```
?CB [channel]
```

Alternatively, the following query can be run to view the state of the logic level of each Hall inputs.

```
?HS [channel]
```

The Hall-only mode requires only a one time tuning during which their actual angular position of each Hall sensor will be detected and stored. See "Automatic Sensor Setup" on page 107.

Hall + Encoder

If the motor is fitted with Hall sensors and an Incremental Encoder, the controller can be configured to use both sensors together. The Encoder's PPR must be configured as described above. In this mode, the controller's operation is identical to when an Encoder alone is used for feedback, except that there is no need for the reference search sequence described above. When first energized, the motor will operate using the Hall sensor until the first change to the Hall pattern is detected. This will set the angle reference for the encoder. For this mode, it is critical that both the number of Encoder PPRs and the motor number of pole pairs be entered correctly. Both counters must count in the same direction.

The Hall Encoder mode requires only a one time tuning during which their actual angular position of each Hall sensor will be detected and stored. See "Automatic Sensor Setup" on page 107.

See above and below how to verify that the Encoder and Hall sensors are operating correctly.

Sin/Cos Analog

Some controller models can be interfaced to absolute position sensors with Sine/Cosine output. These sensors are usually made using Hall technology and are built into the motor. They provide two analog voltage output that are usually 90 degrees apart. The rotor angle is determined by measuring the voltage ratio between the two signals. The controller can compensate for differences in amplitudes between the two signals.

There are sensors whose signals are not 90 degrees apart. The controller can be configured for use with sensors that have practically any phase shift. This is done using the PSA - Phase Shift Angle configuration parameter. Note that angles are in 0-511 degrees notation.

The proper operation of the Sin/Cos sensor can be verified by plotting in real time the voltages of the sin and cos signals inside the Diagnostic tab of the PC utility

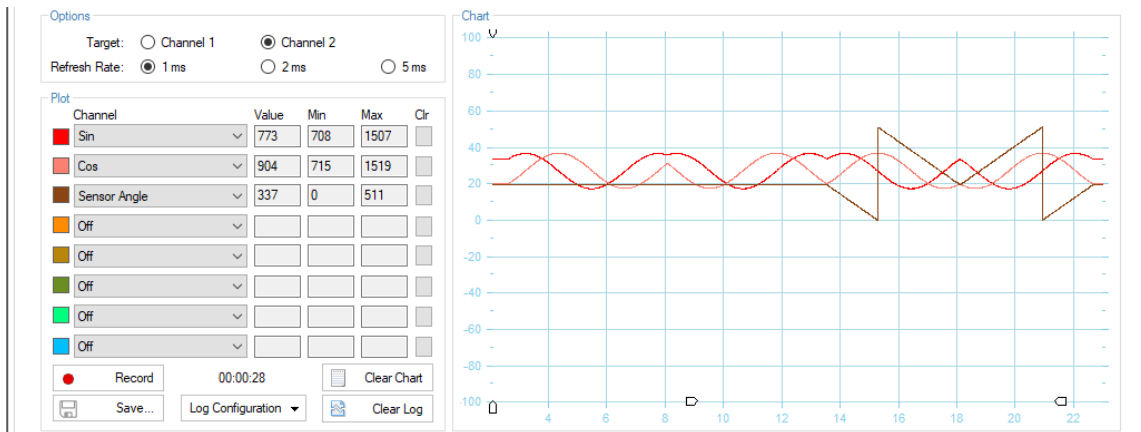

FIGURE 8-10. Diagnostic Tab with Auto Setup

Or using the following queries.

?ASI [channel]

Sin/cos sensors require a one-time setup and calibration. See “Automatic Sensor Setup” on page 107.

Important Warning

The Tuning Fault LED will be on in the Roborun screen and the motor will NOT start if the Sin/Cos has not been setup/calibrated.

Important Notice

Electrical noise on the sensor output will cause wrong angle readings. Shield the wires and keep them as far as possible from the motor wires. If noise persists, add a 10nF to 100nF ceramic capacitor between the input pin and ground pin on the controller’s connector

Synchro Resolver

Synchro Resolvers are a form of Sine/Cosine sensor based on transformer technology. It is composed of a fixed primary coil, and two secondary coils positioned at 90° from each other and that rotate with the rotor. A fixed frequency excitation voltage is fed in the primary. As the secondary coils turn, and take turn being parallel with the fixed primary, the voltage amplitude induced in each varies as shown in the figure below.

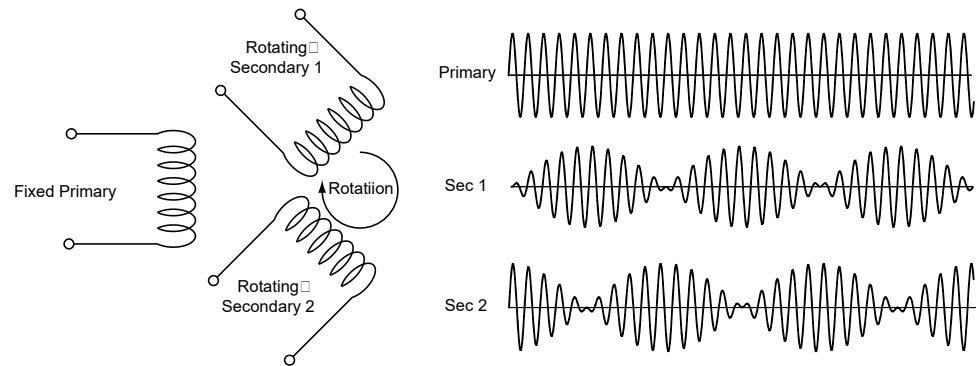

FIGURE 8-11. Resolver equivalent diagram and signals

Controllers models supporting resolvers use one output to generate the excitation. The secondaries are then fed to two analog inputs. Exact wiring depends on the controller model. Please consult the controller data sheet for pinout location. Resolvers require one time calibrations similar to these for the sin/cos sensors and can be tested the same way.

Important Warning

The Tuning Fault LED will be On in the Roborun Screen and the motor will NOT start if the Resolver has not been setup/calibrated.

Digital Absolute Encoder (SSI) Feedback

Some advanced motors, incorporate an absolute position sensor with a high speed serial interface based on the SSI protocol.

Controllers support SSI encoders with resolution from 12 to 15bits. SSI encoders give the angle's absolute position. Nevertheless, a calibration of the zero-angle reference must be done once in order to capture the mechanical offset of the sensor vs the actual 0 degrees position.

The SSI's sensor resolution is set by entering 2 to the power of the number of bits (i.e. 4096, 8192, ...) in the SPI/SSI Sensor Resolution field in the PC utility..

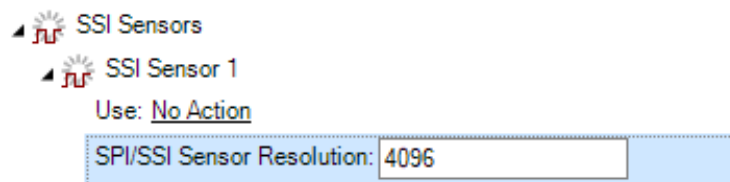

Or by sending the configuration command:

^SCPR channel nn

After enabling the Sinusoidal Mode and SSI Angle Feedback, verify first that the SSI Counter displays a stable number that is different from zero. This will indicate that data is

output from the sensor and captured by the controller. Rotate the motor by hand to verify that the counter changes.

The 12 to 15 bit raw value of the SSI sensor can be read using the query:

?CSS [channel]

The continuous 32-bit counter and speed that is driven by the SSI sensor can be read using the following queries respectively:

?CSS [channel]

?SS [channel]

Typically, SPI encoders are single pole sensors, meaning that they output 0 to their maximum value over a full mechanical turn.

Important Notice

The SSI sensor is used for commutation only. It cannot be used for position mode. Use single turn sensor only. Multi-turn sensors are not supported.

Preparation for Automatic Sensor Setup

The rotor's angle sensor is a critical element for good sinusoidal commutation. Wrong or unstable angle reading can cause excessive current consumption, vibration, or even damage. The sensor must be correctly and firmly attached to the motor so that it never slips during operation. The table below shows the setup and calibration steps required for each sensor type.

Setup	Encoder	Hall	Hall+ Encoder	SSI	Sin/Cos	Resolver
Min/Max Range Calibration	No	No	No	No	Yes	Yes
Zero reference search	Yes(1)	No	No	Yes	Yes	Yes
Hall Position Mapping	No	Yes(2)	Yes(2)	No	No	No
Linearity Correction Map	No(3)	No	No(3)	Yes(3)	Yes	Yes
Sensor/Winding Order	Yes	Yes	Yes	Yes	Yes	Yes

Note 1: Zero reference search must be performed at every power-up for Encoder mode

Note 2: Hall position mapping is optional but recommended for best results

Note 3: Linearity Correction is optional for digital encoders

Sensor setup and calibration is generally a one-time procedure. Sensor information is stored in the controller's configuration and calibration flash.

Reference Search Power

During the automatic sensor setup phase, the controller will drive the motor coils with a slow-changing three phase current, creating a rotating magnetic field inside the motor. The rotor's magnets are attracted to the field, causing the rotor to follow turn. For best accuracy the rotor is driven for a full turn in the forward direction, and another full turn in the reverse direction.

For the reference search to work, the current that is injected into the motor must be strong enough to pull the rotor in perfect alignment. The motor must not be loaded during this sequence. For best results, the current should be set to half of the motor's nominal amps rating.

Enter the value in Amps s in the "Reference Seek Power" configuration menu in the Roborun PC utility.

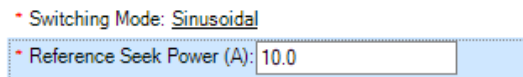

Or by sending the configuration command:

^SREF channel amps (in amps * 10)

Important Warning

Do not select an amperage value that is above the maximum nominal value published in the motor's datasheet.

Important Warning

Calibration data is specific to a motor+sensor set. Changing the motor and/or sensor requires recalibration.

Sensor Min/Max Range

Analog sensors like Sin/Cos and Resolvers have voltage output swings that can vary from one sensor to another. During Automatic Setup, the motor is forced into rotation and the min and max voltages for each sensor output signal is captured over a full turn of the sensor. These values then determine offsets and multiplier that are saved in calibration memory and subsequently used to scale the signals as necessary to produce a correct angle measurement.

The min/max range calibration is a one time operation for a given sensor.

Zero Reference Search for Absolute Sensors

All absolute sensors (Sin/Cos, Resolver, SSI) cannot be trusted to be mounted so that their 0 degree reference position exactly matches this of the motor's windings. During Zero Reference search, the motor is driven over known angular positions. The sensor measurement is compared with the expected rotor position and an Angle Adjustment value is computed and stored in configuration memory.

Important Notice

All angles values entered or displayed by the controller are in 0-511 value where 0 = 0 degrees or radians, and 511 is 360o or 2 ρ radians.

Zero Reference Search for Incremental Encoders

Incremental Encoders do not output an absolute position value. The Zero Reference search is therefore performed every time the controller is powered on. See also “Incremental Encoder-Only” on page 103

Hall Sensors Position Mapping

Hall sensors are often not precisely located at the 0, 60, 120, 180, ... positions. While some imprecision has little effect in trapezoidal mode, misalignment of even a few degrees will have disruptive effect when operating in sinusoidal mode. When used with Hall sensors, the automatic setup procedure captures and maps the angle at which each of the six hall transitions occurs within an electrical turn, regardless of their wiring order.

Linearity Correction Map

Sensor are not always totally linear. This causes the sensed angle to be measured with periodic errors along the sensor travel. During the automatic setup process, the controller maps the values read from the sensor for every mechanical degree over a full turn. It then build a correction table which is applied in real-time as the motor spins.

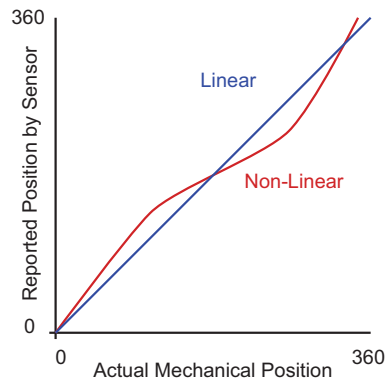

FIGURE 8-12. Sensor non-linearity correction

Windings and Sensor Order.

The wiring order of the U, V, W motor cable, the A, B, C Hall Sensors inputs, the A, B Encoder inputs and/or the Sin, Cos signals are all related to each other. Swapping any of the motor wires will make the motor turn in the opposite direction. Swapping any sensor cables affects the angle and counting direction.

The Automatic Setup will detect the wiring order of the motor and sensors, and set the corresponding bits in the SWD configuration register in order to virtually swap the connections so that all are moving/sensing in the same direction.

Running the Automatic Sensor Setup

The V2.x firmware has a new feature for Automatic Setup and Calibration of all the supported rotor sensor types. With a simple click, it performs the following:

- Find the sensor polarity with respect to stator winding connection and set the SWD Swap Windings configuration parameter.
- Find angle offset from the stator zero degrees reference axis and store the value in the "BADJ" Angle Zero Adjust configuration register.
- Map the angular position of the Hall sensors and store the values in the HSAT Hall Sensor Angle configuration table
- Find the min, max and zero levels of the analog signals in case of sin-cos and resolver for normalization of sine and cosine. The values are stored in the ZSMC calibration register

After configuring the controller for sinusoidal mode (See page 100) and after selecting and configuring the Angle Sensor (See page 102) , click on the Diagnostic tab of the Roborun+ PC Utility.

Important Notice

All angles values entered or displayed by the controller are in 0-511 value where 0 = 0 degrees or radians, and 511 is 360o or 2π radians.

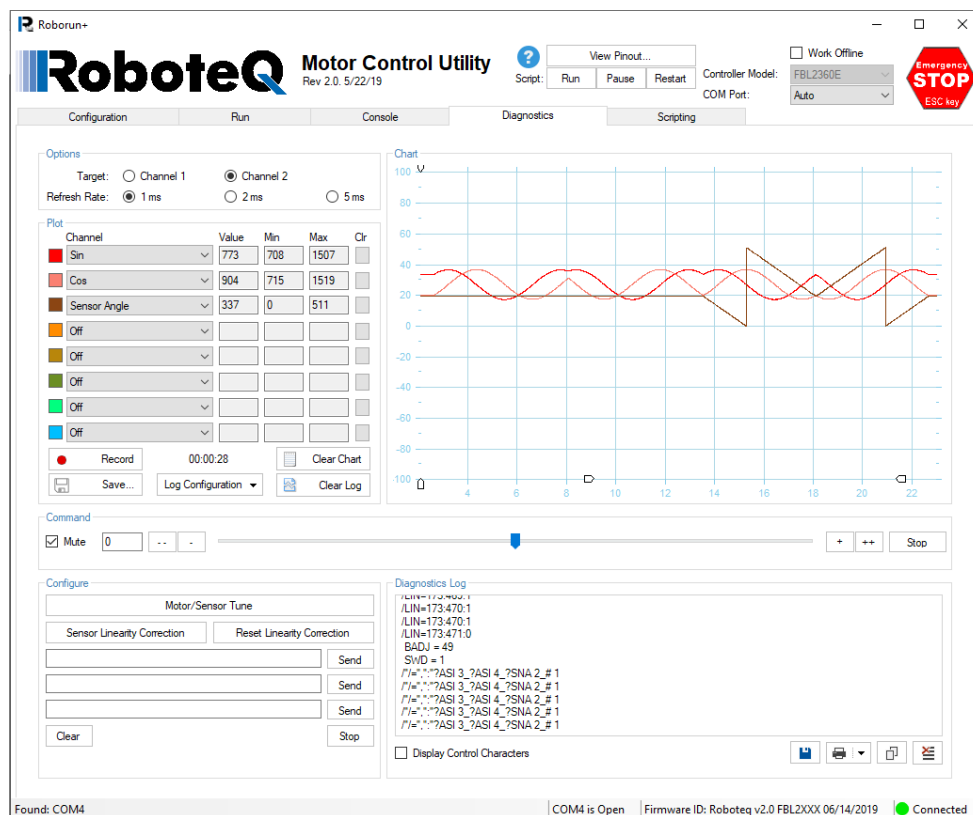

FIGURE 8-13. Diagnostic Tab with Auto Setup

Select which motor channel to setup. Then click on the Motor/Sensor Setup button to launch the Automatic process. The process can also be initiated using the serial commands %CLMOD 2 for Channel 1 and %CLMOD 3 for Channel 2.

The motor will rotate at a RPM speed of 60/Number of Pole pairs. It will perform a full turn in each direction and then stop. If the motor doesn't turn, or turns with hesitations, Click on the Cancel button (or send %CLMOD 0). Make sure that the motor is not loaded. Adjust the Reference Search Current and try again. See "Reference Search Power" on page 108.

After setup is finished, depending on the sensor type, the Utility will print the following captured parameters on the console tab indicating that the process is complete:

Sensor	Captured Values	Description
All types	BADJ SWD	Zero Reference Winding/Sensor Order
Hall, Hall+Encoder	HSAT	Hall Sensor Map
Sin/Cos, Resolver	ZSMC	Min/Max/Zero

Perform the Setup a few times to verify that it produces the same values. If the Zero Reference in particular varies significantly, increase the Adjust the Reference Search Current and try again. See "Reference Search Power" on page 108.

The reference search will settle on a given electrical angle location. On a two pole motor, this electrical angle value exists in 2 mechanical locations for that motor. After performing a first search, rotate the motor shaft and repeat the search. On a perfectly constructed motor, the search will settle at the same electrical angle on any of the other poles. In practice, it is expected that the values will be off by one or two degrees from one pole to another.

If the value is consistent from one measurement to another, and difference is larger than a few degrees, this means the poles are not placed with precision in the motor and the motor will not run efficiently. If the difference is very large (20 degrees or more), it is likely that the angle sensor is not working correctly or that the number of poles of the motor and/or sensor are not configured correctly.

Real-Time Charting

The Diagnostic tab includes a Fast-Updating that can be used to monitor useful information during the Setup phase. For instance for observing that the Sin and Cos inputs see a Sinusoidal shaped signal as the motor turns, or that the captured angle is changing steadily without noise or glitches. The chart is also useful for testing the motor immediately after Setup. The table below shows the parameters that can be monitored in the chart.

Parameter	Description
Sin	Voltage at Sin input of Sin/Cos or resolver
Cos	Voltage at Sin input of Sin/Cos or resolver
Electrical Angle	Electrical Angle
Calibration Angle	Angle of the forced field applied during auto-setup
Sensor Angle	Angle measured by the sensor
Motor Power	PWM Level applied to the motor
Motor Amps	Motor Amps
FOC Flux Amps	Flux Amp, Direct Current, Id (cause no torque)
FOC Torque Amps	Torque Amps, Quadrature Current, Iq (cause torque)
Hall Status	State of all 3 Hall into a single 0-7 value
Hall A	State of Hall A input
Hall B	State of Hall B input
Hall C	State of Hall C input
FOC Angle Correction	Correction determined and applied by FOC
Battery Volts	Battery Volts
Power Per Phase U	PWM on Phase U
Power Per Phase V	PWM on Phase V
Power Per Phase W	PWM on Phase W
Sense U	Sensed voltage level at output U
Sense V	Sensed voltage level at output V
Sense W	Sensed voltage level at output W
BEMF U	BEMF voltage on floating phase U (sesorless-only)
BEMF V	BEMF voltage on floating phase V (sesorless-only)
BEMF W	BEMF voltage on floating phase W (sesorless-only)
BEMF Integrator	BEMF Integrator (sesorless-only)

Important Notice

All angles values entered or displayed by the controller are in 0-511 value where 0 = 0 degrees or radians, and 511 is 360o or 2 ρ radians.

Sensor Linearity Correction

For Sin/Cos, Resolver and SSI encoders, it is possible to automatically check and eventually apply automatic correction to the sensor linearity. From the diagnostics tab, select channel 1 or 2 and press the "Sensor Linearity Correction" button. The motor will spin for a few electrical revolutions and then stop.

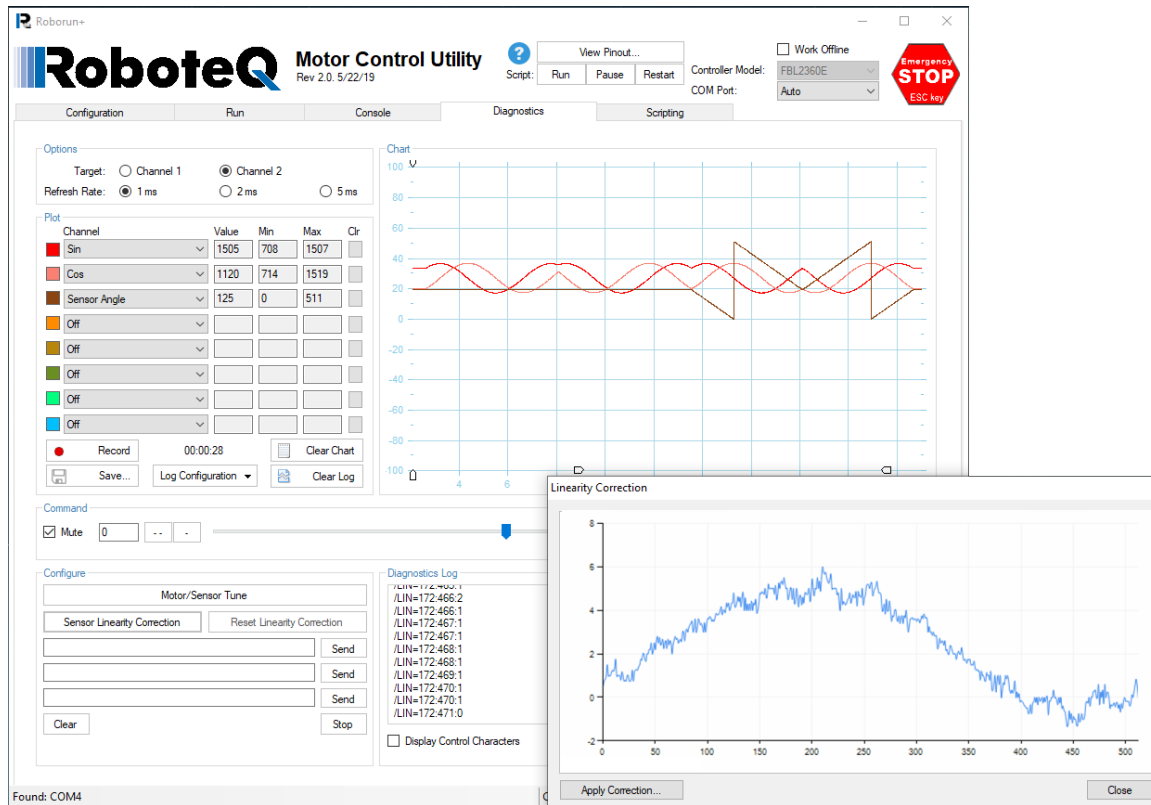

FIGURE 8-14. Sensor Linearity Capture and Correction

The linearity of the sensor will be displayed on the screen. If the graph is flat at around zero value, the sensor is linear and no correction is needed. If the shape is not a flat line and is clean (i.e. without random noise and glitches), press “Apply Correction” button. It can be beneficial to capture the linearity curve a few times and verify that it is consistent, before applying it. If the graphs is noisy, has glitches or looks otherwise unusual, then press close and do the Sensor Linearity procedure again. If the performance is not better then the correction can be cleared by pressing the “Reset Linearity Correction” button.

Basic Motor Check

After the Automatic Setup completed successfully, the motor is ready to run. Use the sliders on the Diagnostics Tab or on the Run Tab to apply power. Always run first in open loop, and preferably with no or light load. Apply first a small command (100-200) and verify that the motor spins without noise or rumble while using low current. Run the motor in the opposite direction and verify that for the same command value, it reaches the same speed and draws the same current. If the motor runs smoothly and with symmetrical performance, repeat the test with higher command value.

If the performance is different in the forward vs reverse direction, the zero reference may be wrong. Run the setup again. Noise or rumble typically points to problems with the sensor.

Field Oriented Control (FOC)

In sinusoidal modes, using the rotor angle to determine the voltage to apply to each of the 3 motor phase works well at low frequencies, and therefore at low rotation speed. At higher speed, the effect of the winding inductance, back EMF and other effect from the motor rotation, create a shifting current. The resulting magnetic field is then no longer optimally perpendicular to the rotor's permanent magnets.

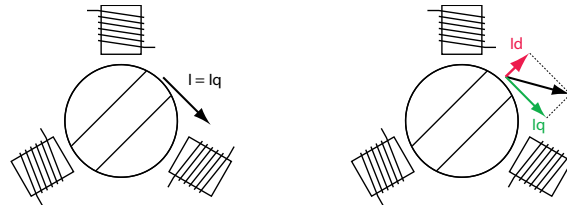

FIGURE 8-15. Perpendicular and non-perpendicular fields

As can be seen in figure 8-10, when the magnetic field is at an angle other than exactly perpendicular to the rotor's magnets, the rotor is pulled by a force that can be decomposed in two forces:

Lateral force causing torque, and therefore rotation. This force results from the Quadrature current I_q , which is also called Torque current

Parallel force that pulls the rotor outwards, creating no motion. This force results from the Direct Current I_d , which is also called Flux current

Field Oriented Control is a technique that measures the useful Torque current and wasted Flux current component of the motor current. It then automatically adjust the power and phase applied to each motor wire in order to eliminate the wasted Flux current

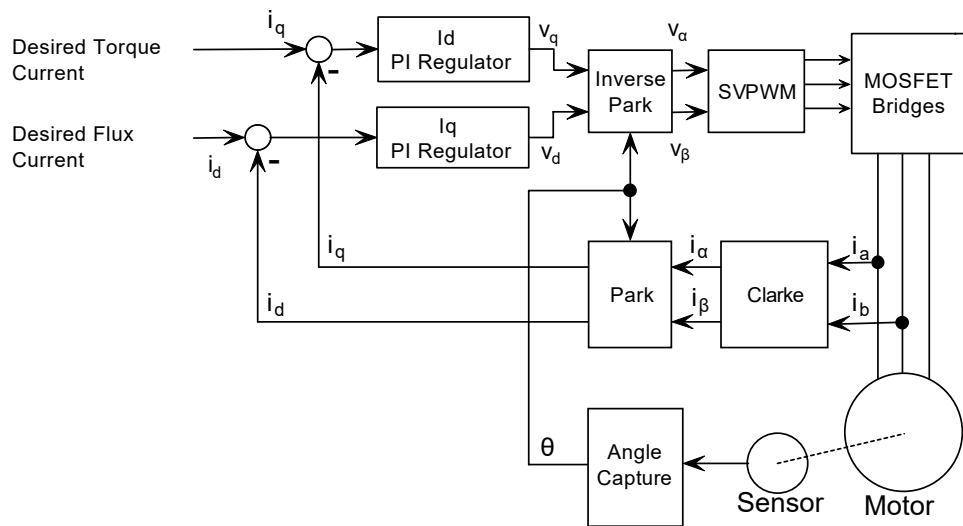
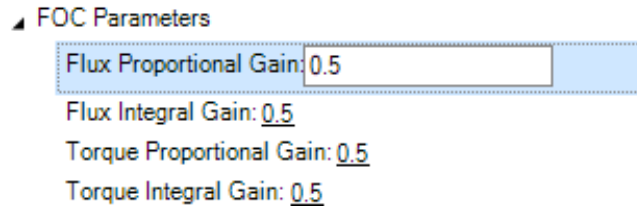

FIGURE 8-16. FOC operation

Field Oriented Control is available on most models of Roboteq motor controllers. It uses a classical implementation as described in the figure 8-11. The current in the motor phase is captured, along with the rotor's angle. From this are computed the useful I_q and wasteful I_d . Two Proportional-Integral (PI) regulators then work to control the power output so that the desired Torque (I_q) and Flux (I_d) currents are met. The desired Flux current is typically set to 0, and so the regulator will work to totally eliminate the Flux current.

Both PI regulator have user-settable gains. They can be changed from the menus in the RoborunPlus utility.



Or by sending the configuration command for single Channel Controllers:

^KPF 1 nn = Proportional Gain for Channel 1 Flux
 ^KPF 2 nn = Proportional Gain for Channel 1 Torque

^KIF 1 nn = Integral Gain for Channel 1 Flux
 ^KIF 2 nn = Integral Gain for Channel 1 Torque

Or by sending the configuration command for dual Channel Controllers:

^KPF 1 nn = Proportional Gain for Channel 1 Flux
 ^KPF 2 nn = Proportional Gain for Channel 2 Flux
 ^KPF 3 nn = Proportional Gain for Channel 1 Torque
 ^KPF 4 nn = Proportional Gain for Channel 2 Torque

^KIF 1 nn = Integral Gain for Channel 1 Flux
 ^KIF 2 nn = Integral Gain for Channel 2 Flux
 ^KIF 3 nn = Integral Gain for Channel 1 Torque
 ^KIF 4 nn = Integral Gain for Channel 2 Torque

Where nn = Gain * 1000000, e.g. 12500000 = 12.5 (on version 2.x of firmware)

FOC Gains Determination & Tuning

Good PI gains are important for the controller to quickly reach and stabilize the desired I_d and I_q current. A very good approximation of the gain values can be calculated from the motor's Resistance and Inductance using the formulas:

$$\text{Flux Proportional gain} = \text{Motor Phase Inductance(Henry)} * \text{Bandwidth}$$

$$\text{Flux Integral gain} = \text{Motor Phase Resistance(Ohm)} * \text{Bandwidth}$$

Bandwidth is in rad/sec and according to Nyquist criteria the current loop bandwidth cannot be more than the half of the current loop sampling time. Most commonly the current loop bandwidth is set to the 1/10-1/20 of the current loop sampling time. The current loop sampling time is at 1kHz. So if we choose as current loop bandwidth the 50Hz then:

$$1\text{Hz} = 2\pi \text{ rad/sec}$$

$$\text{So for 50Hz Bandwidth} = 50 * 2\pi \text{ rad/sec} = 314.$$

Usually even smaller bandwidth can be as effective as the 50Hz. It is better to start with the smaller possible gains and then tune according to the behavior of the motor. Test in open loop with caution.

Example calculation for 50Hz bandwidth, 11mOhm Phase resistance and 90uH Phase Inductance

$$K_i = 0.011 * 314 = 3.45$$

$$K_p = 0,00009 * 314 = 0.028$$

FOC Testing and Troubleshooting

Verify that FOC is operating correctly by monitoring the following values with the PC Utility:

Channel	Value	Min	Max	Clr
DC/Peak Amps 1	<input type="text"/>	<input type="text"/>	<input type="text"/>	<input type="checkbox"/>
Motor Amps 1	<input type="text"/>	<input type="text"/>	<input type="text"/>	<input type="checkbox"/>
FOC Flux Amps 1	<input type="text"/>	<input type="text"/>	<input type="text"/>	<input type="checkbox"/>
FOC Torque Amps 1	<input type="text"/>	<input type="text"/>	<input type="text"/>	<input type="checkbox"/>
FOC Angle Correction 1	<input type="text"/>	<input type="text"/>	<input type="text"/>	<input type="checkbox"/>

Optimal performance is achieved when:

- FOC Quadrature Amps are close to 0.
- Motor Amps and FOC Torque Amps values are close.
- FOC Angle Correction is stable for stable motor Power.

Check also when changing motor power how fast FOC Flux Amps is corrected to zero. Tune FOC PI as necessary.

Instable FOC correction is generally a sign of imperfections of the angle sensing (noise, non-linearity, bad calibration, ...). Bad angle sensing causes the wrong values of Id and Iq to be measured, which the FOC algorithm falsely attempts to correct, worsening the current instability.

Field Weakening

Field weakening is a technique that is used to achieve faster motor rotation speed. This is done by having some Flux (Id) current, even though this also introduces some waste. Field Weakening is therefore possible on Roboteq controller by loading a non-zero set point for the Flux current. This can be done from the console, the serial port, or from a MicroBasic script with the command:

```
!GID ch Amps*10
```

The amount of Flux current should be different at low and high speed, typically starting with zero, and increasing after a given RPM threshold is reached. Below is an example of a MicroBasic script that changes the Flux set point according to such a rule

```
top:
Speed = abs(getvalue(_S, 1)) ` Read motor speed from Encoders
if (Speed > 5000) ` check if above 5000 RPM
FluxSetpoint = (Speed - 5000) / 100 ` 1A per 100 RPM above 5000
else
FluxSetpoint = 0 ` No Flux current below 5000 RPM
end if

if (FluxSetpoint > 100) then FluxSetpoint = 100 ` Cap to 10.0 Amps

setcommand(_GID, 1, FluxSetpoint) ` Apply Flux setpoint
wait(10)
goto top ` repeat every 10ms
```

Sensorless Trapezoidal Commutation

Some Roboteq controllers models support trapezoidal commutation without the need for Hall or other sensors. These models use the code letters "SM" in their product reference (e.g. KSM1660). Roboteq's sensorless control of BLDC motors uses back-EMF integration technique which provides good startup and precise commutation timing.

Important Notice

The Sensorless technique and settings described in this section only apply to firmware revision 2.0 and newer. Earlier implementation of Sensorless commutation has been retired and replaced.

Theory of Operation

At any given time during rotation, two windings are energized and the third is floating. When a BLDC motor rotates, each winding generates BEMF. This BEMF, and therefore the rotor position, can be sensed by monitoring the floating winding.

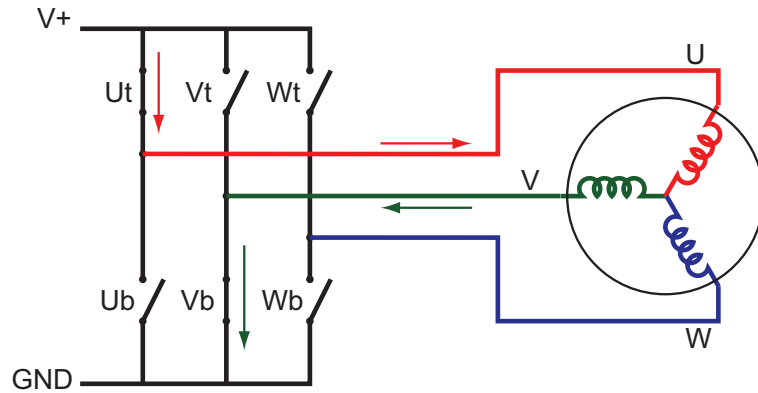

FIGURE 8-17. Active and floating phases

The figure above shows the state of the transistor switches during one of the six commutations phases. The current flows from the battery through the U winding, then through the V winding to ground. The W winding is floating. Since no current is flowing through W, the W terminal has the voltage potential of the BEMF that is induced in the W winding, added to the voltage at the motor's center point. The center point motor is exactly half the V+ voltage, assuming that all windings have the same resistance..

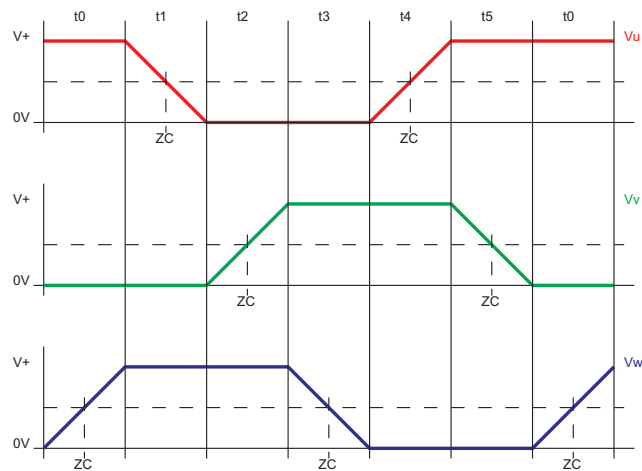

FIGURE 8-18. Six-phases Trapezoidal commutation, BEMF and Zero Crossing

The figure above shows the voltage at each of the windings during the 6 commutation phases. Notice how the voltage of the floating phase ramps between 0 and V+, and between V+ and 0, as the rotor moves 60 degrees. The point in the ramp that is exactly at half the supply voltage is called Zero Crossing. Commutation must occur 30 degrees of rotation later. Roboteq controllers use Back EMF Integration technique in order to determine that precise moment.

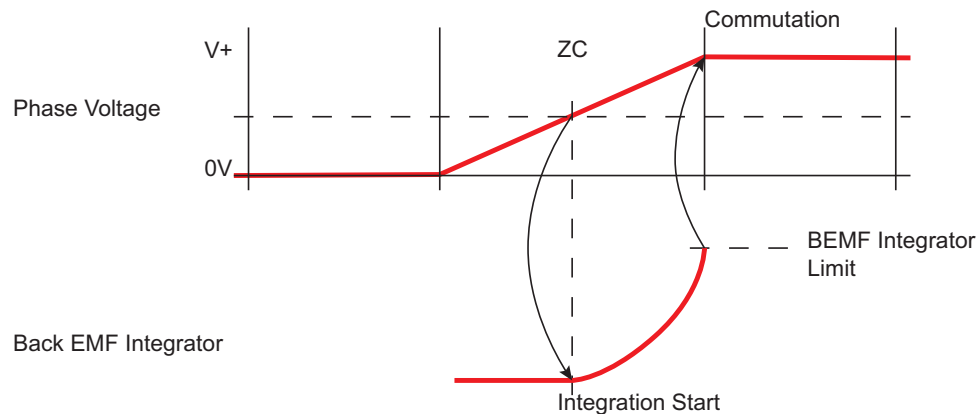

FIGURE 8-19. Commutation based on Back EMF Integration

Detection of rotor position using the BEMF at zero and very low speeds is not possible. At startup, the motor is therefore operated by applying a fixed commutation sequence and runs as a stepper motor until sufficient speed is gathered to detect Back EMF and Zero Crossings. Sensorless can therefore NOT be used if torque is required at stall or very slow speed. Nevertheless, there are many applications (e.g., fans, pumps, watercraft thrusters) that do not require high torque at very low speed.

Important Notice

Do not use sensorless commutation if torque is required at start or at very low speed. Always use sensored motors when driving wheels. Sensorless works best for driving propellers or fans.

Sensorless Parameters

The following parameters need to be tuned for trapezoidal sensorless to work optimally.

- Startup Frequency (SSF): This is minimum frequency (electrical Hz) at which the motor will always try to commutate during motor start or when slowed down.
- Back EMF Integrator Limit (SVT): This defines the threshold at which the integrated back-EMF of a given phase will trigger the commutation.
- Back EMF Coupling Constant (BECC): In case of non-ideal back-EMF waveforms, this number is required to compensate for back-EMF coupling due to other two phases.
- PWM Frequency: In order for BEMF Integration to perform optimally, the PWM Frequency changes automatically dynamically within a min and max value..

The “Startup Frequency (Hz)” is set to 10Hz by default. This frequency works for practically all motors. Some motors with high friction, heavy load and/or high inertia may not start at all, or start unreliably. If this occurs, try different Startup Frequency values.

PWM Frequency is set to 16kHz by default. Lowering the frequency helps the Back EMF detection at low speed and can therefore help improve startup. See discussion below.

In the sensorless mode the motor will spin regardless of the phase wiring order. If the motor spin in the opposite direction than the one desired, swap any two of the three motor wires, or change the motor direction to Inverted in the motor configuration..

The number of poles setting is not necessary in order for the motor to run. The number of poles is only used to measure the motor's rotation speed. Enter a negative number of poles in order to change the speed polarity and count direction.

Sensorless PWM Frequency

PWM Frequency is variable when operating in sensorless mode. At startup and very low speeds, the applied PWM Frequency is this from the configuration settings (16kHz default). As the motor speeds up, the PWM Frequency is automatically increased up to 45kHz max. These settings work in practically all conditions and should be left unchanged

A low PWM Frequency improves the precision of the Back EMF measurement at very slow speed. This in turn can help startup in difficult motor conditions. When lowering the frequency, verify that the operation at maximum speed is not affected while the startup improves. Do not go below the 6kHz minimum PWM frequency..

Sensorless Auto-tuning

An auto-tuning mechanism is provided for determining the BECC and SVT values. Beware that the motor will reach maximum speed during calibration/auto-tuning. The auto-tuning sequence lasts around one minute.

Make sure the controller is configured in open loop. Then, from the Diagnostics tab of the Roborun+ Utility, click on the "Motor/Sensor Setup" button from the diagnostics tab of the Roborun+ Utility. The motor will ramp up to two different speeds. If motor fails to start, or starts unreliably, it may be necessary to adjust the Startup Frequency. See "Sensorless Parameters" section above.

After the setup is complete, the motor will stop, BECC and SVT values will be printed on the console and saved in the controller's configurations flash memory.

In case BECC is reported as a negative number, the calibration will be treated as a failure, and the error message "BEMF Integration Limit Detection FAILED!" will be displayed in the console

If the calibration was successful, then motor is ready to use. Send motor commands in open loop and verify that it runs in both direction with reliability startup.

Further verification is possible by using an oscilloscope connected to any of the motor phases. Verify that the signal is symmetrical as shown in figure 8-5. If it is imbalanced, this means that the Back EMF Integrator Limit (SVT) needs further adjustment. You can change the value manually until the left and right ramps look symmetrical.

Important Warning

Beware that the motor will spin at maximum speed during calibration/auto-tuning. Make sure it is safe to do so before initiating. Be ready to cut to power instantly at any time during the tuning process.

Closed Loop Modes in Sensorless

Closed loop speed mode can be used with sensorless motors. The speed is determined by measuring the time between commutations. Sensorless motors will work the same as sensed motors and require similar PID tuning. The only limitation is at very slow speed where the motor cannot be made to go slower than the RPM resulting from the Startup Frequency parameter.

Position modes, and the Speed Position modes cannot be used reliably with sensorless motors.

Operating Brushless Motors

This section covers operating features that are common to Brushless Motor control, regardless of the commutation mode.

Once configured and tuned, a brushless motor can be operated exactly like a DC motor and all other sections in this manual are applicable. In addition, the Hall sensors or encoders, provide extra information about the motor's state compared to DC motors. This information enables the additional features discussed below.

Stall Detection

The rotor sensors and the encoders can be used to detect whether the motor is spinning or not. The controller includes a safety feature that will stop the motor power if no rotation is detected while a given amount of power is applied for a certain time. Three combinations of power and time are available:

- 250ms at 10% power
- 500ms at 25% power
- 1s at 50% power

If the power applied is higher than the selected value and no motion is detected for the corresponding amount of time, the power to the motor is cut until the motor command is returned to 0. This function is controlled by the BLSTD - Brushless Stall Detection parameter (see "BLSTD - Brushless Stall Detection" in Command Reference section). Do not disable the stall protection.

A stall condition is indicated with the "Stall" LED on the Roborun PC utility screen.

In Trapezoidal modes using Hall sensors, the Stall detection looks for changes at any of the Hall sensors inputs. In Sinusoidal modes, the detection uses the speed measurement from the rotor sensor.

Important Notice

In close loop modes, it is quite possible to have the motor stopped while power is applied to them. That could happen while stopped uphill, for example. Select the appropriate triggering level for your application

Speed Measurement using the angle feedback Sensors

Information from Hall, SPI/SSI, sin/cos sensors, (and even Sensorless) is used by the controller to compute the motor's rotation speed.

When Hall sensors are used, speed is determined by measuring the time between Hall sensor transitions. This measurement method is very accurate, but requires that the motor be well constructed and that the placement between sensors be accurate. On precision motors, this results in a stable speed being reported. On less elaborate motors, such as low-cost hub motors, the reported speed may oscillate by a few percent.

Speed measurement is very precise with digital absolute sensors (SPI). Sin/Cos sensors operating without noise also give a very precise value.

The motor's number of poles must be entered as a controller parameter in order to produce an accurate RPM value. See discussion above. The speed information can then be used as feedback in a closed loop system. Motor with a more precise Hall sensor positioning will work better in such a configuration than less precise motors.

If the reported speed is negative when the slider is moved in the positive direction, you can correct this by putting a negative number of poles in the motor configuration. This will be necessary in order to operate the motor in closed loop speed mode using hall sensor speed capture.

Distance Measurement using Hall, SSI or other Sensors

When Hall sensors are used, the controller automatically detects the direction of rotation, keeps track of the number of Hall sensor transition and updates a 32-bit up/down counter. The number of counts per revolution is computed as follows:

$$\text{Counts per Revolution} = \text{Number of Poles} * 6$$

With Resolver or Sin/Cos sensors, the controller accumulates the sensor angle data to recreate an accurate and high resolution 32-bit counter. For these sensors, the number of counts per revolution is:

$$\text{Counts per Revolution} = \text{Number of Sensor Poles} * 512$$

With SSI sensor, the controller accumulates the SSI data difference to recreate an accurate and high resolution 32-bit counter. For these sensors, the number of counts per revolution is:

$$\text{Counts per Revolution} = \text{Number of Sensor Poles} * \text{SSI Sensor CPR}$$

The counter information can then be read via the Serial/USB port, CAN bus, or can be used from a MicroBasic script. The counter can also be used to operate the brushless motor in a Closed Loop Position mode, within some limits

SECTION 9

AC Induction Motor Operation

This section discusses the controller’s operating features and options when using three phase AC Induction motors.

Introduction to AC Induction Motors

Three phase induction motors are the most common types of electrical motors. They have a very simple construction composed of a stator covered with electromagnets, and a rotor composed of conductors shorted at each end, arranged as a “squirrel cage”. They work on the principle of induction where a rotating electro-magnetic field is created by applying a three-phase current at the stator’s electromagnets. This in turn induces a current inside the rotor’s conductors, which in turn produces rotor’s magnetic field that tries to follow stator’s magnetic field, pulling the rotor into rotation.

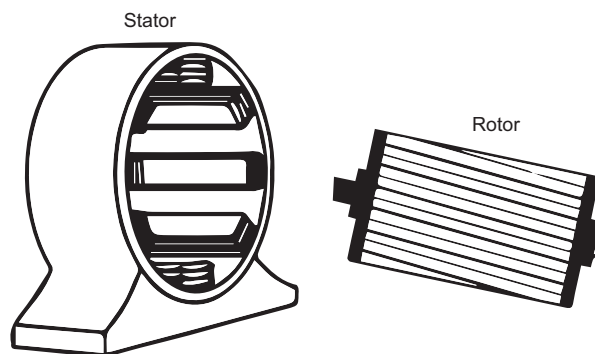

Benefits of AC Induction Motors are:

- Induction motors are simple and rugged in construction. They are more robust and can operate in any environmental condition.
- Induction motors are cheaper in cost due to simple rotor construction, absence of brushes, commutators, and slip rings

- They are maintenance free motors unlike dc motors due to the absence of brushes, commutators and slip rings.
- Induction motors can be operated in polluted and explosive environments as they do not have brushes which can cause sparks

Asynchronous Rotation and Slip

AC Induction motors are Asynchronous Machines meaning that the rotor does not turn at the exact same speed as the stator's rotating magnetic field. Some difference in the rotor and stator speed is necessary in order to create the induction into the rotor. The difference between the two is called the slip.

Slip is measured in Hertz. It is the difference of the frequency generated by the controller, and the rotor's frequency, as determined by the formula

$$f = ((\text{RPM} / 60) * \text{NumberOfPoles})$$

Optimal slip varies from the motor to motor and is in the range of typically 2 to 10Hz.

As seen from the figure below, when the slip is 0, i.e. the rotor turns at exactly the same speed as the stator field, torque totally disappears. Within the stable operating region, the Torque is proportional to the Slip. The torque and motor efficiency then quickly drops when the slip grows past its optimal value.

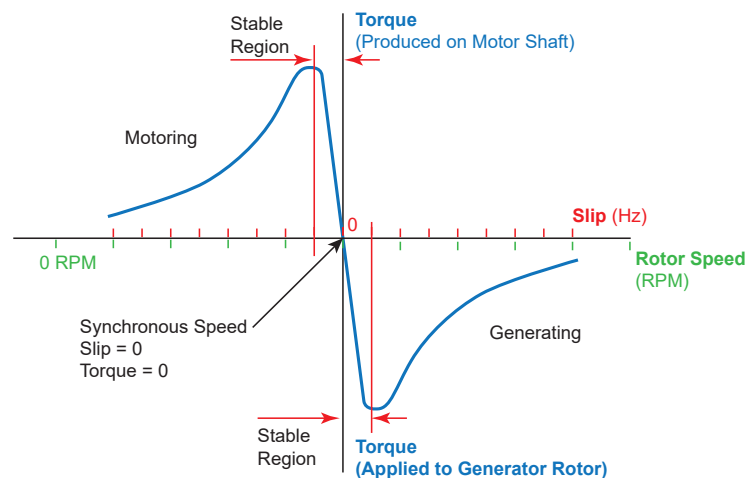

The main task of the motor controller is to generate a rotating magnetic field whose frequency and strength is such that the rotor will operate within the motor's optimal slip range. Three techniques are supported by Roboteq for achieving this:

Scalar, Volts per Hertz (VPH)

Constant Slip

Field Oriented Control

Each of these techniques, benefits, and limitations are described in the following sections

Connecting the Motor

An AC Induction motors have just 3 power wires which must be connected to the controller's U V and W terminals. The connection order is not important. However, swapping any two motor connections will make the motor turn in the opposite direction.

Selecting and Connecting the Encoder

A speed sensor must be used to measure and control the motor's slip when running in Constant Slip mode and Torque/Speed FOC mode. This is done using an incremental encoder. Most AC induction motors come with a built-in quadrature encoder. These encoders typically have a relatively low number of counts. 32 or 64 Pulses Per Revolution (PPR) rotation are typical values. A low count encoder results in low frequency pulses.

When using encoders up to 128 Pulses Per Revolution, the controller evaluates the rotation speed by measuring the time between encoder pulses. This results in measurement with a resolution of 0.1Hz even at full speed.

When using encoders with higher PPR, speed is measured by counting the number of encoder signal transitions over a 10ms period. Prefer therefore a high-count encoder of around 1000 PPR for better speed measurement resolution.

Unless otherwise noted in the product's datasheet, all Roboteq's AC Induction Motor Controllers have to pull up resistors that can connect to open collector encoder outputs. Controllers also have capacitors to help filter out any electrical noises that contribute to fake encoder readings.

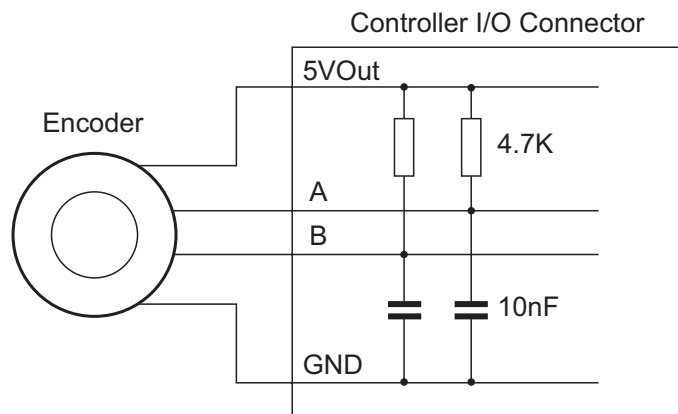

Testing the Encoder

To test the encoder, use the PC utility to enable the encoder and set its number of Pulses Per Revolution (PPR). Go to the Utility's Run tab, enable the Encoder Count in the chart. Make a full turn of the motor shaft by hand. Verify that the counter has changed by the number of PPR * 4.

Prior to enabling Constant Slip or FOC Modes, operate the motor in open loop Volts per Hertz mode with slip control disabled. To disable slip control, set the encoder as No Action in the configuration menu.

Apply a positive motor command. Verify that the motor shaft is moving in the desired direction. If the motor moves in the opposite direction, swap any two of the three motor cables, or change the motor direction to Inverted in the motor configuration.

If the motor moved in the desired direction, then verify that the encoder counter increments when a positive motor command is applied. If the counter decrements, then either swap the A and B encoder wires or enter a negative number of PPRs in the encoder configuration.

Open Loop Variable Frequency Drive Operation

In its simplest operating mode, the controller will output to the motor a three-phase sinusoid whose voltage and frequency change together at a fixed ratio. This mode is called Scalar because of the fixed ratio between the Voltage and Frequency that is applied to the motor.

The ratio is set by the VPH - Volts Per Hertz configuration parameter.

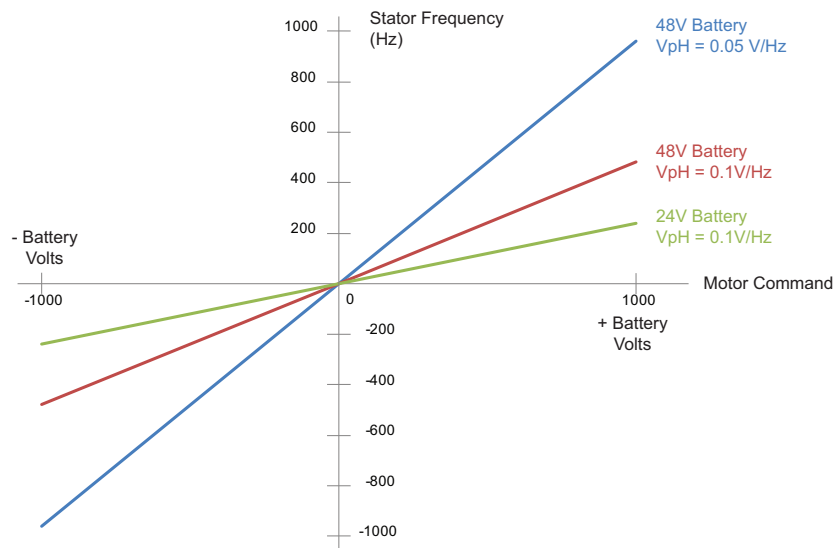

The figure above shows an example of the resulting stator frequency for a given motor command. In open loop mode, Motor commands range from -1000 to +1000 and result in the output voltage to range between -VBat to +VBat respectively

As long as the motor is not overloaded, the rotor RPM will be

$$((\text{Stator Frequency} - \text{Slip}) / \text{Number of Pole Pairs}) * 60$$

Figuring the Motor's Volts per Hertz

Each motor has a value for the optimal Volts per Hertz ratio. It can be determined by the operating frequency and rated voltage written of the motor's label. The figure below shows values from a real motor.

Watt	3500
V	48Bat
Amps	100
RPM	1450
Nm	23
50Hz	V fase 3 x 27
Encoder 64 Pulses	

For this motor, the VPH can be determined by dividing the 27 Volts per phase by the 50Hz frequency. In this case 0.54 Volts per Hertz.

Note that this value is for the optimal torque as rated on the label. If the load is a lot lighter, the VpH will be too high and result in excessive current consumption. If the load is a lot heavier, the VpH will be too low and the motor will not be able to drive it. The VpH will therefore need to be different from this computed based on actual load conditions. Always first monitor the motor consumption at no load. Adjust the VpH to a lower value if the no load current appears too high.

Maintaining Slip within Safe Range

Open Loop, or Scalar, the mode does not require encoders for its operation. If the load is known to always be within the motor's max torque, the motor can be trusted to always be able to drive it. In this case, an encoder does not need to be connected. If an encoder is connected - to measure and report speed, for example - then it must be configured as "No Action" in the PC Utility.

For added safety, however, an encoder can be installed and enabled to measure the rotor's speed, and therefore the slip, in real-time. When the encoder is enabled and configured as "Feedback," the controller will lower the voltage and frequency if the slip exceeds twice the value stored in the Optimal Slip configuration.

Prior to enabling the encoder as Feedback, verify that the encoder count direction has the same polarity as the motor command.

Closed Loop Speed Mode with Constant Slip Control

In this mode, the controller will automatically adjust the voltage and frequency in order to reach and maintain the desired speed, even as the load is changing, while operating within the optimal slip range.

To configure this mode, first set the controller in open loop mode as described in the previous section. Verify that the encoder is working and is counting with the correct polarity.

Once the encoder is verified to work and the motor spins in the open loop, follow these steps. Using the Roborun PC utility:

- Select Close Loop Constant Slip Mode
- Set the PID gains found in the Motor Output, Closed Loop Speed Parameters menus (do not use the FOC PID gains). Try first with gains of $P=4$, $I=0.5$, $D=0$. These values will produce adequate results in most cases. Additional tuning may be needed.
- Set the Max RPM configuration to the speed that must be reached at full throttle (ie when command = 1000). Make sure to enter a value that is within the physical reach of the motor under the expected maximum load condition.
- Enter the lowest acceleration rate that is acceptable for the application. Rapid changes will create current surges and should therefore not be allowed to be higher than necessary.
- Save the settings to the controller.

The motor speed can now be set to be any value between 0 and plus/minus the maximum RPM configured above when sending a command ranging from -1000 to +1000 using the serial, analog or pulse inputs.

The motor speed can also be set to an absolute RPM value by sending the S (Speed) command via serial, USB, CAN or Scripting.

When exercising the motor with the PC utility, monitor the Slip, the Rotor RPM, Stator RPM and the Motor Amps.

The slip will stabilize at the Optimal Slip setting.

Field Oriented Control (FOC) mode Operation

Field Oriented Control (or Vector Drive) is a technique by which the magnetic field generated in the stator is adjusted in relation to the field induced in the rotor in a manner to generate optimal torque at all times and all load conditions.

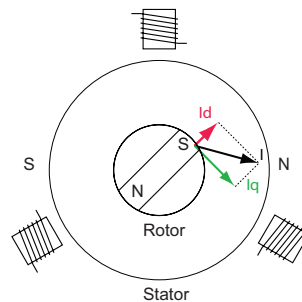

The optimal rotation occurs when the magnetic field induced in the rotor is perpendicular with this of the stator. Practically the fields the two fields are never exactly perpendicular. As shown in the diagram above, the angled field I is made of an outward pulling flux field (I_d) and perpendicular pulling torque field. The torque field is the one that causes the rotation and that the controller will maximize. Flux field is not causing any rotation and therefore must be minimized. Some flux is necessary at all times, however, in order to create the induction in the rotor.

The challenge in induction motors is that the rotor flux's absolute position cannot be measured physically. It is determined mathematically using known speed, voltage and current, and a model representation of the motor's main parameters shown in the figure below.

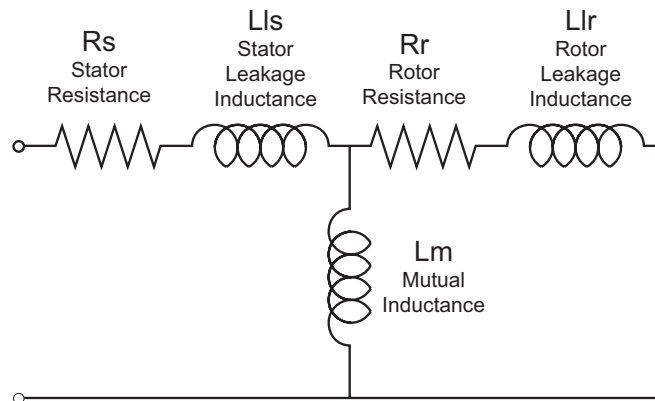

These parameters include per phase rotor resistance 'Rr', rotor leakage inductance 'Llr', mutual inductance 'Lm' and rotor leakage inductance 'Llr'. Usually, motor manufacturer will provide you an equivalent circuit of the induction motor that contains Rr, Rs, Lm, Llr, Lls

In FOC, therefore, rotor flux and motor torque can be individually controlled regardless of load and speed. FOC offers better dynamic performance, accurate current control and ensures maximum efficiency, unlike traditional scalar control methods such as Open Loop VpH and Constant Slip Control.

Under FOC operation, AC induction motors can be run in either FOC torque mode or FOC speed mode. FOC torque mode allows users to command a torque to a motor in terms of Amps. While FOC speed will regulate the speed at the command/desired value.

Configuring FOC Torque Mode

To configure FOC mode, first set the controller in Open Loop (Volts per Hertz) mode as described in one of the previous sections. Verify that the motor is spinning in the desired direction and that encoder is working and is counting with the correct polarity. See Testing the Encoder section above.

Once the encoder is verified to work and the motor spins in the open loop, follow these steps. Using the Roborun PC utility:

- Enter the motor parameters under the section "Motor Parameters" in RoboRun configuration. Usually, motor manufacturer will provide you an equivalent circuit of the induction motor that contains Rr, Rs, Lm, Llr, Lls.
- Set the Flux Amps. In order to find the optimal flux amps, run the motor in Volts per Hertz (VpH) mode with small/no load using the motor's rated VpH ratio. Then watch the flux amps in the PC utility. Enter this value in the configuration. This flux amps can be increased for low speed/high torque requirement and can be decreased (Field Weakening) for high speed/ low torque requirement.
- Set the operating mode to FOC torque. Set Amps limit according to the application's need but do not exceed the motor specifications.
- Save the settings to the controller.
- Next step is to tune FOC (Flux and Torque) PID. Start with low proportional gain e.g. 0.1, and then set some Integral gain. Integral gain is more important in this case. Alternatively use the method as described in chapter "FOC Gains Tuning" in Section 8, using the Stator Resistance (Rs) and the Stator Inductance (Ls).

- Monitor and Record the Flux Amps and Torque Amps for the desired motor channel when tuning the FOC PID.
- Put some high load on the rotor and command a step Torque Amps from the slider bar (say 10A). Record the "FOC Torque Amps" reading on the chart. If the step response reaches the desired (10A) steady state fast enough then the PID is can be considered tuned. If it is slow then increase integral gain. If the Torque and Flux Amps show noise at high speed or motor produces noisy sound, then lower your proportional gain Kp.
- Once FOC/current PID is tuned, FOC torque mode is ready to operate and FOC speed mode can then be tuned. Note: It is important to know the value of Flux Amps the motor is designed to operate under. Flux Amps stay the same during entire FOC operation unless field weakening is used.

Now motor Torque can be set to any desired value from 0 to plus or minus the value stored in the Amps Limit configuration parameter, by sending a command of -1000 to +1000 using the slider, analog input, pulse input, scripting, CAN or any other command mode.

Note that in Torque Mode, the Max Speed RPM configuration parameter is used to limit the motor speed if the motor is not loaded and the desired torque is below the torque that can actually be reached by the motor under the current load conditions. For example, a torque command of 50A on an unloaded motor (that will never draw 50A) will cause the voltage to increase to the maximum value, and therefore the motor to maximum speed, unless the speed is limited by the Max RPM parameter. For more details see chapter "Speed Limiting in FOC Torque Mode" below.

Configuring FOC Speed Mode

To configure FOC Speed mode, configure first the FOC Torque mode as described in the section above.

- Set the controller to FOC Speed Mode
- Tune speed loop PID in a similar manner as was done for FOC PID. Use the PID gains found in the Motor Output, Closed Loop Speed Parameters menus (do not use the FOC PID gains). It can be started with Kp term and introduce small Kd term. Once transient response on the graph seems reasonable then Ki can be used to get rid of steady state error.

Now motor Speed can be set to any desired value from 0 to plus or minus the value stored in the Max RPM configuration parameter, by sending a command of -1000 to +1000 using the slider, analog input, pulse input, scripting, CAN or any other command mode.

E.g. use the Roborun slider, or the console command

```
!G 1 800
```

to set motor RPM to 800 on channel 1 when MaxSpeed is set to 1000 RPM. Corresponding if MaxSpeed is set to 2000 RPM, any value on the slider will give 2 times RPM.

Speed can be also set as an absolute RPM value using the S command from Serial, USB, CAN or Microbasic.

Speed Limiting in FOC Torque Mode

AC Induction Controllers provide a way of smoothly limiting the speed in FOC torque mode to prevent motor runaways. The method for limiting the speed is based on PID speed over-ride control which provides very smooth motor output but requires PID tuning.

The speed loop PID tuning can either be done in "FOC torque mode" at the speed limit or in "FOC Speed Mode" by looking at the response time.

- When in "FOC Torque Mode," command some torque to the motor and cause the motor to spin to the speed limit. Some low frequency ripple will be noticed in the speed which should be minimized by increasing PID gains. Increase the PID gains to a point where no ripple is seen.
- If in "FOC Speed Mode," tune the speed PID gains by looking at the response time of the motor. And then move to case 1) to check the ripple in the speed.

SECTION 10

Closed Loop Speed and Speed-Position Modes

This section discusses the controller's Closed Loop Speed modes.

Modes Description

Close loop speed modes ensure that the motor(s) will run at a precisely desired speed. If the speed changes because of changes in load, the controller automatically compensates the power output so that the motor maintains a constant speed. Two closed loop speed modes are available:

Closed Loop Speed Mode

This mode is the traditional closed loop technique where speed is measured with a speed sensor. The speed is compared to the desired speed and a PID control loop adjusts the power output up or down in order to reach and maintain that speed.

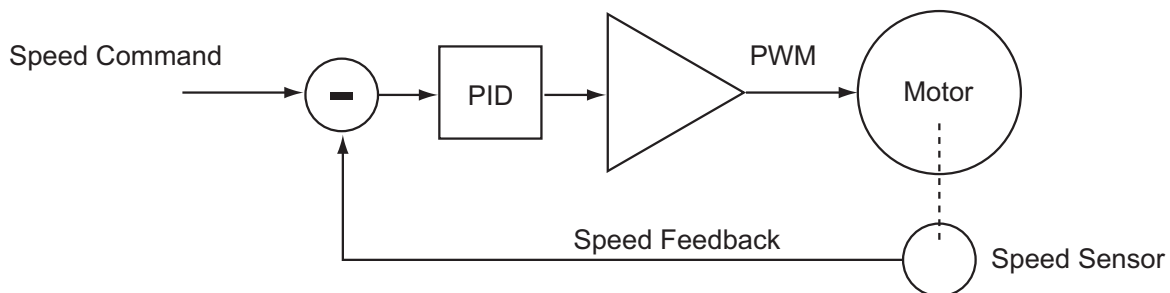

Closed Loop Speed Position Control

In this mode, the controller computes the position at which the motor must be at every 1ms. Then a PID compares that expected position with the current position and applies the necessary power level in order for the motor to reach that position. This mode is especially effective for accurate control at very slow speeds.

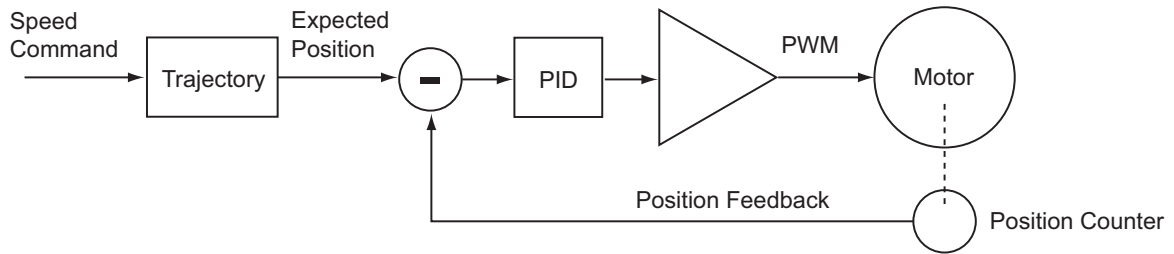

The controller incorporates a full-featured Proportional, Integral, Differential (PID) control algorithm for quick and stable speed control.

The closed loop speed mode and all its tuning parameters may be selected individually for each motor channel.

Motor Sensors

The controller can use a variety of sensors for measuring speed. For brushed DC, Digital Optical Encoders and Analog Tachometers may be used. For Brushless motors, the Hall sensors and all other types of rotor sensors can be used in addition to Encoders and Tachometers. Digital Optical Encoders may be used to capture accurate motor speed.

Analog tachometers are another technique for sensing speed. See “Connecting Tachometer to Analog Inputs” on page 48

Tachometer or Encoder Mounting

Proper mounting of the speed sensor is critical for an effective and accurate speed mode operation. Figure 10-1 shows a typical motor and tachometer or encoder assembly. It is always preferable to have the encoder connected to the motor shaft rather than at the output of a gearbox. If the encoder must be mounted after a gear box considers the effect of the gear backlash. A higher count encoder will typically be required to compensate for the lower rotation speed.

Analog Tachometer or Optical Encoder

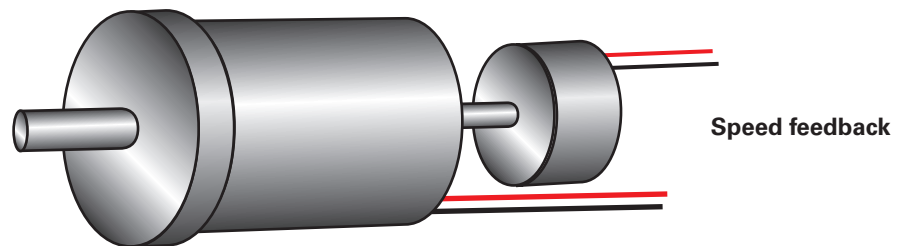

FIGURE 10-1. Motor and speed sensor assembly needed for Close Loop Speed mode

Tachometer wiring

The tachometer must be wired so that it creates a voltage at the controller’s analog input that is proportional to rotation speed: 0V at full reverse, +5V at full forward, and 0 when stopped.

Connecting the tachometer to the controller is as simple as shown in the diagram below.

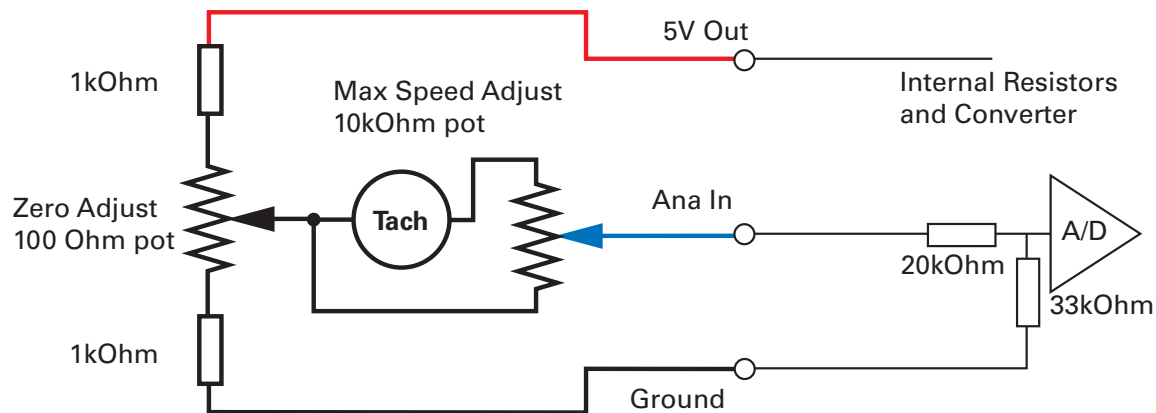

FIGURE 10-2. Tachometer wiring diagram

Brushless Hall Sensors as Speed Sensors

On brushless motor controllers, the Hall Sensors and most other types of rotor position sensors that are used to switch power around the motor windings, can also be used to measure speed and distance traveled.

Speed is evaluated by measuring the time between the transition of the Hall Sensors. A 32 bit up/down counter is also updated at each Hall Sensor transition.

Speed information picked up from the Hall Sensors can be used for closed loop speed operation without any additional hardware. Likewise, the position counter that is updated at every Hall transition can also be used to operate the motor in Speed Position mode.

Speed Sensor and Motor Polarity

The tachometer, encoder or brushless sensor (Hall, Sin/Cos, SPI) polarity (i.e. which rotation direction produces positive or negative speed information) is related to the motor's rotation speed and the direction the motor turns when power is applied to it.

In the Closed Loop Speed mode, the controller compares the actual speed, as measured by the sensor, to the desired speed. If the motor is not at the desired speed and direction, the controller will apply power to the motor so that it turns faster or slower, until reached.

Important Warning

The speed sensor polarity must be such that a positive voltage is generated to the controller's input when the motor is rotating in the forward direction. If the polarity is inverted, this will cause the motor to run away to the maximum speed as soon as the controller is powered and eventually trigger the closed loop error and stop. If this protection is disabled, there will be no way of stopping it other than pressing the emergency stop button or disconnecting the power.

Determining the right polarity is best done experimentally using the Roborun utility (see “Roborun+ Utility User Manual”) and following these steps:

1. Configure the controller in Open Loop Mode using the PC utility. This will cause the motor to run in Open Loop for now.
2. Configure the sensor you plan to use as speed feedback. If an analog tachometer is used, map the analog channel on which it is connected as “Feedback” for the selected motor channel. If an encoder is used, configure the encoder channel with the encoder’s Pulses Per Revolution value. On the brushless motor, if the rotor sensor (Hall, Sin/Cos, ..) sensors are used, configure the correct number of motor pole pairs.
3. Click on the Run tab of the PC utility. Configure the Chart recorder to display the speed information if an encoder is used. Display Feedback if an analog sensor is used.
4. Verify that the motor sliders are in the “0” (Stop) position.
5. If a tachometer is used, verify that the reported feedback value read is 0 when the motors are stopped. If not, adjust the Analog Center parameter.
6. Move the cursor of the desired motor to the right so that the motor starts rotating, and verify that a positive speed is reported. Move the cursor to the left and verify that a negative speed is reported.
7. If the reported speed polarity is the same as the applied command, the wiring is correct.
8. If the tachometer polarity is opposite of the command. If an encoder is used, swap its ChA and ChB outputs. Alternatively, swap the motor leads if using a brushed DC motor only. The speed polarity can also be inverted by entering a negative number of encoder PPR. On brushless motors, entering a negative number of poles will invert the speed measured by the Hall, SinCos, or Resolver sensor. If using SSI sensor, the speed polarity can be inverted by entering a negative number of SSI sensor resolution.
9. Set the controller operating mode to Closed Loop Speed mode using the Roborun utility.
10. Move the cursor and verify that speed stabilizes at the desired value. If speed is unstable, tune the PID values.

Important Warning

It is critically important that the tachometer or encoder wiring be extremely robust. If the speed sensor reports an erroneous speed or no speed at all, the controller will consider that the motor has not reached the desired speed value and will gradually increase the applied power to the motor until the closed loop error is triggered and the motor is then stopped.

Controlling Speed in Closed Loop

When using encoder feedback or Hall Sensor (brushless motor) feedback, the controller will measure and report speed as the motor’s actual RPM value.

When using analog or pulse as input command, the command value will range from 0 to +1000 and 0 to -1000. In order for the max command to cause the motor to reach the de-

sired actual max RPM, an additional parameter must be entered in the encoder or brushless configuration. The Max RPM parameter is the speed that will be reported as 1000 when reading the speed in relative mode. Max RPM is also the speed the controller will attempt to reach when a max command of 1000 is applied.

When sending a speed command via serial, CANbus, scripting or USB, the command may be sent as a relative speed (0 to +/-1000) or actual RPM value.

PID Description

The controller performs both Closed Loop Speed modes using a full featured Proportional, Integral and Differential (PID) algorithm. This technique has a long history of usage in control systems and works on performing adjustments to the Power Output based on the difference measured between the desired speed or position (set by the user) and the actual speed or position (captured by the sensor on the motor).

Figure 9-3 shows a representation of the PID algorithm. Every 1 millisecond, the controller measures the actual motor speed or position and subtracts it from the desired speed or position to compute the error.

The resulting error value is then multiplied by a user selectable Proportional Gain. The resulting value becomes one of the components used to command the motor. The effect of this part of the algorithm is to apply power to the motor that is proportional with the difference between the current and desired speed or position: when far apart, high power is applied, with the power being gradually reduced as the motor moves to the desired speed or destination.

A higher Proportional Gain will cause the algorithm to apply a higher level of power for a given measured error thus making the motor react more quickly to changes in commands and/or motor load.

The Differential component of the algorithm computes the changes to the error from one 1 ms time period to the next. This change will be a relatively large number every time an abrupt change occurs on the desired speed value or the measured speed value. The value of that change is then multiplied by a user selectable Differential Gain and added to the output. The effect of this part of the algorithm is to give a boost of extra power when starting the motor due to changes to the desired speed or position value. The differential component will also help dampen any overshoot and oscillation.

The Integral component of the algorithm performs a sum of the error over time. In Speed mode, this component helps the controller reach and maintain the exact desired speed when the error is reaching zero (i.e. measured speed is near to, or at the desired value). In Speed Position mode, the Integral parameter can help maintain a slightly tighter difference between the desired and actual position, but makes no significant difference and can be omitted altogether.

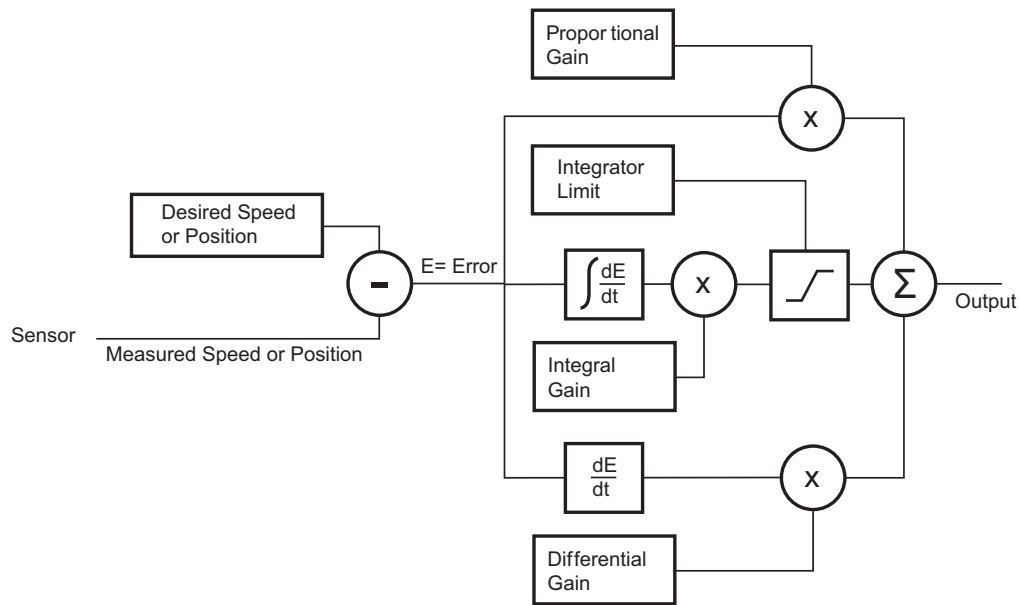

FIGURE 10-3. PID algorithm used in speed modes

PID tuning in Closed Loop Speed Mode

As discussed above, three parameters - Proportional Gain, Integral Gain, and Differential Gain - can be adjusted to tune the Closed Loop Speed control algorithm. The ultimate goal in a well tuned PID is a motor that reaches the desired speed quickly without overshoot or oscillation.

Because many mechanical parameters such as motor power, gear ratio, load, and inertia are difficult to model, tuning the PID is essentially a manual process that takes experimentation.

The Roborun PC utility makes this experimentation easy by providing one screen for changing the Proportional, Integral and Differential gains and another screen for running and monitoring the motor. First, run the motor with the preset values. Then experiment with different values until a satisfactory behavior is found.

In Speed Mode, the Integral component of the PID is the most important and must be set first. The Proportional and Differential components will help improve the response time and loop stability.

Try initially to only use a small value of I and no P or D:

$$\begin{aligned} P &= 0 \\ I &= 1 \\ D &= 0 \end{aligned}$$

These values practically always work, but they may cause the motor to be slowly reaching the desired speed. Increase the I gain to improve responsiveness but keeping it below the level at which the motor begins to oscillate. The experiment then with adding P gain, and different values of I.

In the case where the load moved by the motor is not fixed, tune the PID with the minimum expected load and tune it again with the maximum expected load. Then try to find values that will work in both conditions. If the disparity between minimal and maximal possible loads is large, it may not be possible to find satisfactory tuning values. In this case, consider changing the PID gains on the fly during motor operation with serial/CAN commands or with a MicroBasic script

In slow systems, use the integrator limit parameter to prevent the integrator to reach saturation prematurely and create overshoots. Beware to set speeds that can physically be reached by the motor under load. If the motor is not physically able, there will be a loop error, which if it becomes too large, will cause a fault to be detected and the motor to be stopped.

PID Tuning in Speed Position Mode

As discussed, in Closed Loop Speed Position mode, every millisecond, the controller computes a successive desired position. The PID then works to make the motor follow the computed trajectory. This mode works much better than the regular Closed Loop Speed mode when the motor must operate at very low speed. When the motor is stopped, it will maintain its position even if pulled, as for example on a robot stopped downhill.

The PID therefore must be tuned for position mode. In position mode, most of the work is done by the proportional gain. It acts essentially as an imaginary rubber belt between the controller's internal destination counter and the motor: the higher the difference, the more the belt is stretched, and the stronger the motor will turn. Once the imaginary belt has stiffened the motor will run at the desired speed.

Try initially with only a small amount of P gain

P = 2
I = 0
D = 0

With the controller configured in Speed Position mode and the motor stopped, do a first check of the PID's stiffness by attempting to rotate the motor by hand. It should feel increasingly hard to rotate away from the rest position. With a higher P gain, it will become harder to move than lower gains. As a rule of thumb, on a mobile robot, use a gain that makes it very hard to move the wheel more than a quarter turn away from the rest position. Test then by applying a speed command and verifying the motor runs smoothly under all load conditions.

The I and D gain can generally be omitted in Speed Position mode.

Beware to set speeds that can physically be reached by the motor under load. The Closed Loop Speed Position mode relies on the fact that the motor will actually be able to follow the computed trajectory. If the motor is not able, the controller will pause updating the destination counter until the motor caught up. This will result in inaccurate speed and can be a problem in mobile robot applications depending on precise control of their left and right side motor.

Error Detection and Protection

The controller will detect large tracking errors due to mechanical or sensor failures, and shut down the motor in case of problem in closed loop speed or position system. The detection mechanism looks for the size of the tracking error (desired position vs. actual position) and the duration the error is present. Three levels of sensitivity are provided in the controller configuration:

- 1: 250ms and Error > 100
- 2: 500ms and Error > 250
- 3: 1000ms and Error > 500

When an error is triggered, the motor channel is stopped until the error has disappeared or when the motor channel is reset to open loop mode. The error is cleared when a stop command is issued.

Clearing the loop error make the motor available for moving again. However, this does not mean that the loop error will not happen again. Configuration tuning is necessary in order to prevent from having Loop Error again. The loop error value can be monitored in real time using the Roborun PC utility.

SECTION 11

Closed Loop Relative and Tracking Position Modes

This section describes the controller's Position Relative and Position Tracking modes, how to wire the motor and position sensor assembly and how to tune and operate the controller in these modes.

Modes Description

In these two position modes, the axle of a geared-down motor is coupled to a position sensor that is used to compare the angular position of the axle versus a desired position. The controller will move the motor so that it reaches this position.

This feature makes it possible to build ultra-high torque "jumbo servos" that can be used to drive steering columns, robotic arms, life-size models and other heavy loads.

The two position modes are similar and differ as follows:

Position Relative Mode

The controller accepts a command ranging from -1000 to +1000, from serial/USB, analog joystick, or pulse. The controller reads a position feedback sensor and converts the signal into a -1000 to +1000 feedback value at the sensor's min and max range respectively. The controller then moves the motor so that the feedback matches the command, using a controlled acceleration, set velocity, and controlled deceleration. This mode requires several settings to be configured properly but results in very smoothly controlled motion.

Position Tracking Mode

This mode is identical to the Position Relative mode in the way that commands and feedback are evaluated. However, the controller will move the motor simply using a PID comparing the command and feedback, without controlled acceleration and as fast as possible. This mode requires fewer settings but often results in a motion that is not as smooth and harder to control overshoots.

Selecting the Position Modes

The two position modes are selected by changing the Motor Control parameter to Closed Loop Position. This can be done using the corresponding menu in the Power Output tree in the Roborun utility. It can also be done using the associated serial (RS232/RS485/TCP/USB) command. See “MMOD” on page 310. The position mode can be set independently for each channel.

Position Feedback Sensor Selection

The controller may be used with the following kinds of sensors:

- Potentiometers
- Hall effect angular sensors
- Optical Encoders
- Hall sensor in brushless motor

The first two are used to generate an analog voltage ranging from 0V to 5V depending on their position. They will report an absolute position information at all times.

Modern position Hall sensors output a digital pulse of the variable duty cycle. These sensors provide an absolute position value with high precision (up to 12-bit) and excellent noise immunity. PWM output sensors are directly readable by the controller and therefore are a recommended choice.

Optical encoders report incremental changes from a reference which is their initial position when the controller is powered up or reset. Before they can be used for reporting position, the motors must be moved in open loop mode until a home switch is detected and resets the counter. Encoders offer the greatest positional accuracy possible.

Sensor Mounting

Proper mounting of the sensor is critical for an effective and accurate position mode operation. Figure 11-1 shows a typical motor, gear box, and sensor assembly.

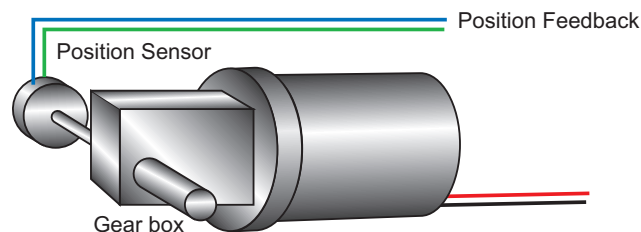

FIGURE 11-1. Typical motor/Potentiometer/assembly in Position Mode

The sensor is composed of two parts:

- a body which must be physically attached to a non-moving part of the motor assembly or the robot chassis, and
- an axle which must be physically connected to the rotating part of the motor you wish to position.

A gear box is necessary to greatly increase the torque of the assembly. It is also necessary to slow down the motion so that the controller has the time to perform the position control algorithm. If the gearing ratio is too high, however, the positioning mode will be very sluggish.

A good ratio should be such that the output shaft rotates at 1 to 10 rotations per second (60 to 600 RPM) when the motor is at full speed.

The mechanical coupling between the motor and the sensor must be as tight as possible. If the gear box is loose, the positioning will not be accurate and will be unstable, potentially causing the motor to oscillate.

Some sensors, such as potentiometers, have a limited rotation range of typically 270 degrees (3/4 of a turn), which will in turn limit the mechanical motion of the motor/potentiometer assembly. Consider using a multi-turn potentiometer as long as it is mounted in a manner that will allow it to turn throughout much of its range, when the mechanical assembly travels from the minimum to maximum position. When using encoders, best results are achieved when the encoder is mounted directly on the motor shaft.

Feedback Sensor Range Setting

Regardless of the type of sensor used, feedback sensor range is scaled to a -1000 to +1000 value so that it can be compared with the -1000 to +1000 command range.

On analog and pulse sensors, the scaling is done using the min/max/center configuration parameters.

When encoders are used for feedback, the encoder count is also converted into a -1000 to +1000 range. In the encoder case, the scaling uses the Encoder Low Limit and Encoder High Limit parameters. See "Serial (RS232/USB) Operation" on page 161 for details on these configuration parameters. Beware that encoder counters produce incremental values. The encoder counters must be reset using the homing procedure before they can be used as position feedback sensors.

Important Notice

Potentiometers are mechanical devices subject to wear. Use better quality potentiometers and make sure that they are protected from the elements. Consider using a solid state hall position sensor in the most critical applications. Optical encoders may also be used, but require a homing procedure to be used in order to determine the zero position.

Important Warning

If there is a polarity mismatch, the motor will turn in the wrong direction and the position will never be reached. The motor will turn until the Closed Loop Error detection is triggered. The motor will then stop until the error disappears, the controller is set to Open Loop, or the controller is reset.

Determining the right polarity is best done experimentally using the Roborun utility (see “Roborun+ Utility User Manual”) and following these steps:

1. Configure the controller in Open Loop Speed mode.
2. Configure the position sensor input channel as position feedback for the desired motor channel.
3. Click on the Run tab.
4. Enable the Feedback channel in the chart recorder.
5. Move the slider slowly in the positive direction and verify that the Feedback in the chart increases in value. If the Feedback value decreases, then the sensor is backward and you should either invert using configuration commands, invert the sensor physically, it or swap the motor wires so that the motor turns in the opposite direction.
6. Move the sensor off the center position and observe the motor’s direction of rotation.
7. Go to the max position and verify that the feedback value reaches 1000 a little before the end of the physical travel. Modify the min and max limits for the sensor input if needed.
8. Repeat the steps in the opposite direction and verify that the -1000 is reached a little before the end of the physical travel limit.

Important Safety Warning

Never apply a command that is lower than the sensor’s minimum output value or higher than the sensor’s maximum output value as the motor would turn forever trying to reach a position it cannot. Configure the Min/Max parameter for the sensor input so that a value of -1000 to +1000 is produced at both ends of the sensor travel.

Adding Safety Limit Switches

The Position mode depends on the position sensor providing accurate position information. If the sensor is damaged or one of its wires is cut, the motor may spin continuously in an attempt to reach a fictitious position. In many applications, this may lead to serious mechanical damage.

To limit the risk of such breakage, it is recommended to add limit switches that will cause the motor to stop if unsafe positions have been reached independently of the sensor reading. Any of the controller’s digital inputs can be used as a limit switch for any motor channel.

An alternate method is shown in Figure 11-2. This circuit uses Normally Closed limit switches in series on each of the motor terminals. As the motor reaches one of the switches, the lever is pressed, cutting the power to the motor. The diode in parallel with the switch allows the current to flow in the reverse position so that the motor may be restarted and moved away from that limit.

The diode polarity depends on the particular wiring and motor orientation used in the application. If the diode is mounted backwards, the motor will not stop once the limit switch lever is pressed. If this is the case, reverse the diode polarity.

The diodes may be eliminated, but then it will not be possible for the controller to move the motor once either of the limit switches has been triggered.

The main benefit of this technique is its total independence on the controller's electronics and its ability to work in practically all circumstances. Its main limitation is that the switch and diode must be capable of handling the current that flows through the motor. Note that the current will flow through the diode only for the short time needed for the motor to move away from the limit switches.

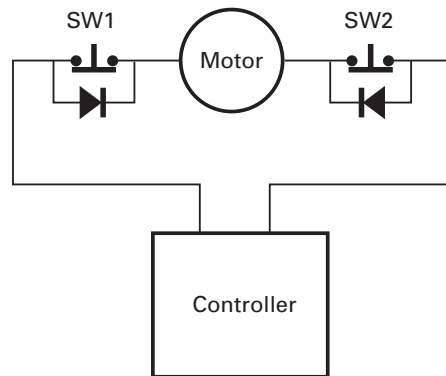

FIGURE 11-2. Safety limit switches interrupting power to the motor

Important Warning

Limit switches must be used when operating the controller in Position Mode. This will significantly reduce the risk of mechanical damage and/or injury in case of damage to the position sensor or sensor wiring.

Using Current Trigger as Protection

The controller can be configured to trigger an action when the current reaches a user configurable threshold for more than a set amount of time. This feature can be used to detect that a motor has reached a mechanical stop and is no longer turning. The triggered action can be an emergency stop or a simulated limit switch.

Operating in Closed Loop Relative Position Mode

This position algorithm allows you to move the motor from an initial position to the desired position. The motor starts with a controlled acceleration, reaches the desired velocity, and decelerates at a controlled rate to stop precisely at the end position. The graph below shows the speed and position vs. time during a position move.

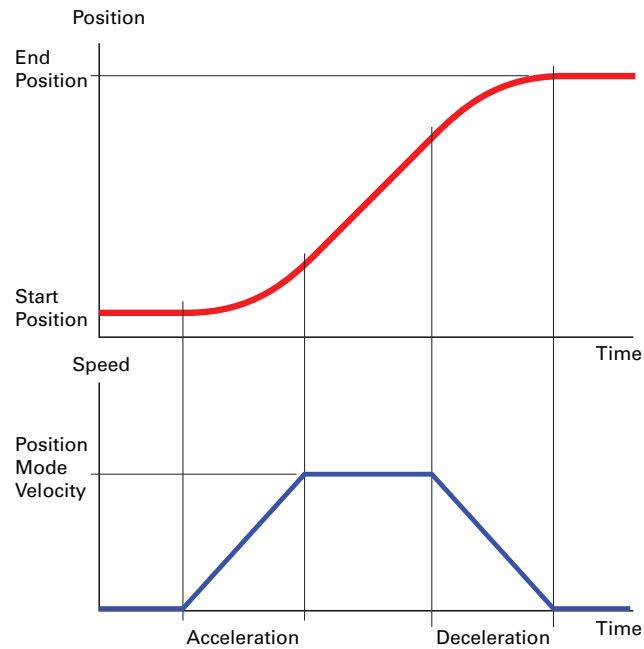

FIGURE 11-3.

When turning the controller on, the default acceleration, deceleration and velocity are parameters retrieved from the configuration EEPROM. In most applications, these parameters can be left unchanged and only change in commands used to control the change from one position to the other. In more sophisticated systems, the acceleration, deceleration and velocity can be changed on the fly using Serial/USB commands or from within a MicroBasic script.

When using Encoders as feedback sensors, the controller can accurately measure the speed and the number of motor turns that have been performed at any point in time. The complete positioning algorithm can be performed with the parameters described above.

When using analog or pulse sensors as feedback, the system does not have a direct way to measure speed or number of turns. It is therefore necessary to configure an additional parameter in the controller which determines the number of motor turns between the point the feedback sensor gives the minimum feedback value (-1000) to the maximum feedback value (+1000).

In the Closed Loop Relative Position mode, the controller will compute the position at which the motor is expected to be at every millisecond in order to follow the desired acceleration and velocity profile. This computed position becomes the setpoint that is compared with the feedback sensor and a correction is applied at every millisecond.

For troubleshooting, the computed position can be monitored in real time by enabling the Tracking channel in the PC utility's chart recorder.

Beware not to use accelerations and max velocity that are beyond the motor's physical reach at full load. This would result in a loop error which will stop the system if growing too large.

Operating in Closed Loop Tracking Mode

In this mode, the controller makes no effort to compute a smooth, millisecond by millisecond position trajectory. Instead, the current feedback position is periodically compared with the requested destination and power is applied to the motor using these two values in a PID control loop.

This mode will work best if changes in the commands are smooth and not much faster than what the motor can physically follow.

Position Mode Relative Control Loop Description

The controller performs the Relative Position mode using a full featured Proportional, Integral and Differential (PID) algorithm. This technique has a long history of usage in control systems and works on performing adjustments to the Power Output based on the difference measured between the desired position (set by the user) and the actual position (captured by the position sensor).

Figure 10-4 shows a representation of the PID algorithm. Every 1 millisecond, the controller measures the actual motor position and subtracts it from the desired position to compute the position error.

The resulting error value is then multiplied by a user selectable Proportional Gain. The resulting value becomes one of the components used to command the motor. The effect of this part of the algorithm is to apply power to the motor that is proportional with the distance between the current and desired positions: when far apart, high power is applied, with the power being gradually reduced and stopped as the motor moves to the final position. The Proportional feedback is the most important component of the PID in Position mode.

A higher Proportional Gain will cause the algorithm to apply a higher level of power for a given measured error, thus making the motor move quicker. Because of inertia, however, a faster moving motor will have more difficulty stopping when it reaches its desired position. It will therefore overshoot and possibly oscillate around that end position.

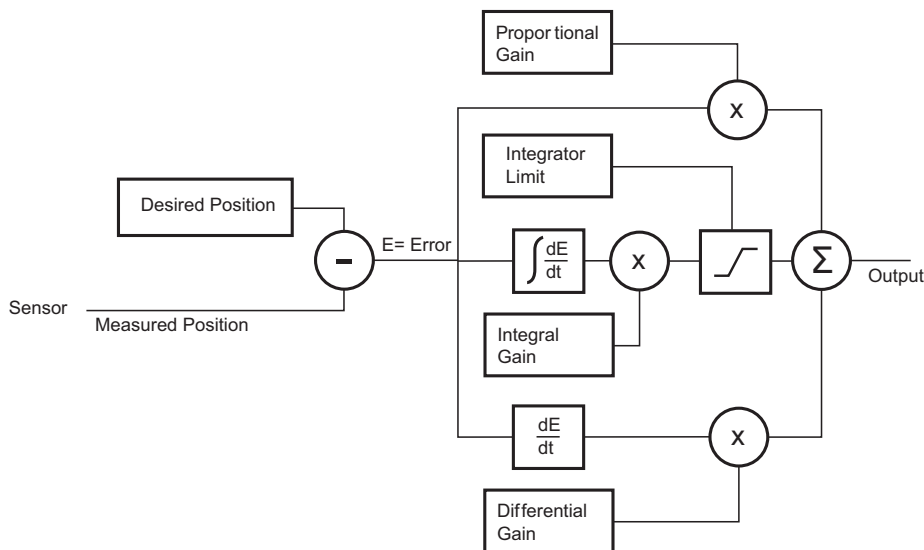

FIGURE 11-4. PID algorithm used in Position Mode

The Differential component of the algorithm computes the changes to the error from one ms time period to the next. This change will be a relatively large number every time an abrupt change occurs on the desired position value or the measured position value. The value of that change is then multiplied by a user-selectable Differential Gain and added to the output. The effect of this part of the algorithm is to give a boost of extra power when starting the motor due to changes to the desired position value. The differential component will also help dampen any overshoot and oscillation.

The Integral component of the algorithm performs a sum of the error over time. In the position mode, this component helps the controller reach and maintain the exact desired position when the error would otherwise be too small to energize the motor using the Proportional component alone. Only a very small amount of Integral Gain is typically required in this mode.

In systems where the motor may take a long time to physically move to the desired position, the integrator value may increase significantly causing then difficulties to stop without overshoot. The Integrator Limit parameter will prevent that value from becoming unnecessarily large.

PID tuning in Position Mode

As discussed above, three parameters - Proportional Gain, Integral Gain and Differential Gain - can be adjusted to tune the position control algorithm. The ultimate goal in a well tuned PID is a motor that reaches the desired position quickly without overshoot or oscillation.

Because many mechanical parameters such as motor power, gear ratio, load and inertia are difficult to model, tuning the PID is essentially a manual process that takes experimentation.

The Roborun PC utility makes this experimentation easy by providing one screen for changing the Proportional, Integral and Differential gains and another screen for running and monitoring the motor.

When tuning the motor, first start with the Integral and Differential Gains at zero, increasing the Proportional Gain until the motor overshoots and oscillates. Then add Differential gain until there is no more overshoot. If the overshoot persists, reduce the Proportional Gain. Add a minimal amount of Integral Gain. Further fine tune the PID by varying the gains from these positions.

To set the Proportional Gain, which is the most important parameter, use the Roborun utility to observe the three following values:

- Command Value
- Actual Position
- Applied Power

With the Integral Gain set to 0, the Applied Power should be:

$$\text{Applied Power} = (\text{Command Value} - \text{Actual Position}) * \text{Proportional Gain}$$

Experiment first with the motor electrically or mechanically disconnected and verify that the controller is measuring the correct position and is applying the expected amount of power to the motor depending on the command given.

Verify that when the Command Value equals the Actual Position, the Applied Power equals to zero. Note that the Applied Power value is shown without the sign in the PC utility.

In the case where the load moved by the motor is not fixed, the PID must be tuned with the minimum expected load and tuned again with the maximum expected load. Then try to find values that will work in both conditions. If the disparity between minimal and maximal possible loads is large, it may not be possible to find satisfactory tuning values.

Note that the controller uses one set of Proportional, Integral and Differential Gains for both motors, and therefore assumes that similar motor, mechanical assemblies and loads are present at each channel.

PID Tuning Differences between Position Relative and Position Tracking

The PID works the same way in both modes in that the desired position is compared to the actually measured position.

In the Closed Loop Relative mode, the desired position is updated every ms and so the PID deal with small differences between the two values.

In the Closed Loop Tracking mode, the desired position is changed whenever the command is changed by the user.

Tuning for both modes requires the same steps. However, the P, I and D values can be expected to be different in one mode or the other.

Loop Error Detection and Protection

The controller will detect large tracking errors due to mechanical or sensor failures, and shut down the motor in case of problem in closed loop speed or position system. The detection mechanism looks for the size of the tracking error (desired position vs. actual position) and the duration the error is present. Three levels of sensitivity are provided in the controller configuration:

- 1: 250ms and Error > 100
- 2: 500ms and Error > 250
- 3: 1000ms and Error > 500

When an error is triggered, the motor channel is stopped until the error has disappeared, the motor channel is reset to open loop mode.

The loop error can be monitored in real time using the Roborun PC utility.

SECTION 12

Closed Loop Count Position Mode

In the Closed Loop Position mode, the controller can move a motor a precise number of encoder counts, using a predefined acceleration, constant velocity, and deceleration. This mode requires that an encoder be mounted on the motor.

Mode description

The desired position is given in the number of counts. Using acceleration, deceleration and top velocity, the controller computes the position at which the motor is expected to be at every one millisecond interval. A PID then computes the power to give to the motor in order to maintain that position. A comparator looks at the desired position and the computed current position and issues a Destination Reached flag. The figure below shows a representation of this mode.

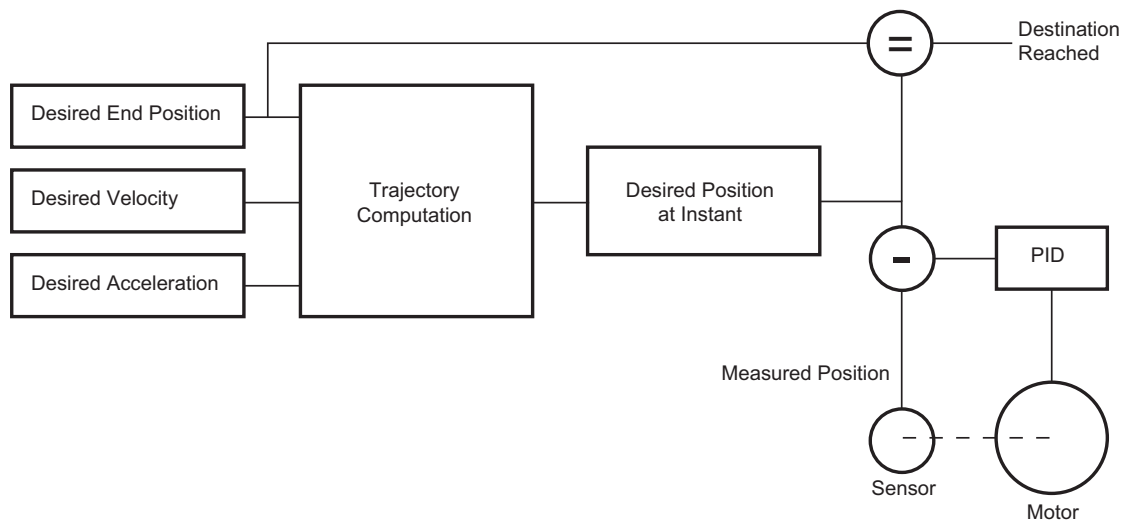

FIGURE 12-1 Closed Loop Position mode

Sensor Types and Mounting

In position mode, best results are achieved with encoders directly mounted on the motor shaft. Encoders can be:

- Quadrature encoders
- Hall Sensors built-in brushless motors
- Other rotor sensors built-in brushless motors

It is not advised to mount encoders at the output of a geared motor as the gear box often introduces backlash. If the encoder must be mounted at the output, then it must typically have a higher count to compensate the lower speed rotation at that location.

Quadrature encoders typically provide the highest resolution since they can be ordered with a line resolution of several hundred or thousands of counts per revolution. Hall encoders built in brushless motors give a relatively low, but often adequate count of $6 * \text{NumberOfPoles}$ per mechanical resolution. SSI digital sensors give a pole resolution equal to their SSI sensor resolution. Other brushless rotor sensors, such as sin/cos or resolver sensors will give up to 512 counts per pole and can therefore be used instead of encoders.

Encoder Home reference

Beware that encoders do not give an absolute position information. It is therefore necessary to perform a search of the zero reference position at least once after every power up. This is typically achieved by moving the motor up to a limit switch and loading the counter with a fixed value at that location. A home search sequence can easily be implemented using a MicroBasic script. The search and counter loading must be done while the motor is operated in an open loop.

SSI Sensor Home reference

When SSI sensors are used as relative encoders, it is as well necessary to perform a search of the zero reference position, as stated above.. When SSI sensors are used as absolute encoders (Absolute Feedback), Home reference is used as an offset to the SSI Counter.

Important Warning

Changing the counter with value while the motor is operated in a closed loop can cause violent and dangerous jumps. Always revert to open loop to change the counter value.

Preparing and Switching to Closed Loop

To enter this mode you will first need to configure the encoder so that it is used as feedback for motor1, and feedback for motor2 on the other encoder in a dual motor system. On brushless motors, selecting "Other" in Closed Loop Feedback Sensor, the encoder or the SSI sensor, if either present and properly configured, will be used as feedback. Selecting "Internal Sensor", Hall, sin/cos or resolver sensor, depending on which is configured, will be used as feedback.

Use the PC Utility to set the default acceleration, deceleration and position mode velocity in the motor menu. These values can then be changed on the fly if needed.

While in Open Loop, enable the Speed channel in the Roborun Chart Recorder. Move the slider in the positive direction and verify that the measured speed polarity is also positive.

If a negative speed is reported, swap the two encoder wires to change the measured polarity, or swap the motor leads to make the motor spin in the opposite direction.

Then use the PC Utility to select the Closed Loop Position Mode. After saving to the controller, the motor will operate in Closed Loop and will attempt to go to the 0 counter position. Beware therefore that the motor has not already turned before switching to Closed Loop. Reset the counter if needed prior to closing the loop.

Count Position Commands

Moving the motor is done using a set of simple commands.

To go to an absolute encoder position value, use the !P command

To go to a relative encoder position count that is relative to the current position, use the !PR command.

The Acceleration, Deceleration and Velocity are fixed parameters that can be changed using the ^MAC, ^MDEC and ^MVEL configuration settings. These can also be changed on the fly, any time using the !AC and !DC commands.

The velocity can also be changed at any time using the !S command:

New position destination command can be issued at any time. If the previous destination is not reached while the new is sent, the motor will move to the new destination. If this causes a change of direction, the motor will do the change using the current acceleration and deceleration settings. See the Commands Reference section for details on all these commands

Position Command Chaining

It is possible to chain position commands in order to create seamless motion to a new position after an initial position is reached. To do this, the controller can store the next goto position with, optionally, a new set of acceleration, deceleration and velocity values.

The commands that set the "next" move are identical to these discussed in the previous section, with the addition of an "X" at the end. The full command list is:

!PX nn mm Next position absolute

!PRX nn mm Next position relative

!ACX nn mm Next acceleration

!DCX nn mm Next deceleration

!SX Next velocity

Example: !PX 1 -50000 will cause the motor to move to that new destination once the previous destination is reached. !PRX -10000 will cause the motor to move 10000 count back from the previous end destination. If the next acceleration, next deceleration or next velocity are not entered, the value(s) used for the previous motion will be used.

Beware that the next commands must be entered while the motor is moving, since the next commands will only be taken into account at the end of the current motion.

To chain more than two commands, use a MicroBasic script or an external program to load new “next” command when the previous “next” commands become active. The ?DR query can be used to detect that this transition has occurred and that a new next command can be sent to the controller.

The chart below shows a typical chaining flow.

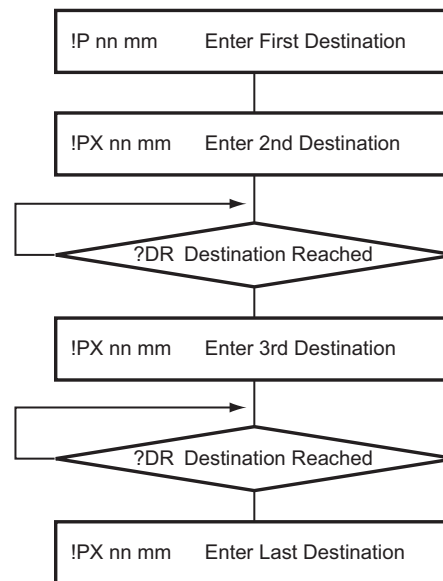

FIGURE 12-2 Command Chaining flow

Position Accuracy Considerations

In the position mode, the controller computes a trajectory that the motor then attempts to follow using a PID. For this technique to work well, the motor must first be physically able to run as fast as dictated by the trajectory calculation. If not, a loop error (ie desired position - actual position) will accumulate and eventually grow to trigger an error that will stop the motor. Make sure that the velocity setting is always under the max speed that can be reached by the motor while running at full load, in open loop.

Some difference between the desired and actual position, i.e. a loop error, is always to be expected when using a PID. The PID gains must be tuned to minimize the loop error while keeping smooth motion. The expected position and loop error can be monitored in real time using the PC utility's Tracking and Loop Error channels, respectively, in the chart recorder.

Beware that the Destination Reached flag will become true when the result of the trajectory computation equals the desired destination. In most practical situations, the motor will still be on its way to actually reach that destination. This can be an important consideration when chaining commands, as the new command will become active before the motor has actually reached the previous destination

PID Tunings

As long as the motor assembly can physically reach the acceleration and velocity, smooth motion will result in relatively little need for tuning. As for any position control loop, the dominant PID parameter is the Proportional gain with only little Integral gain and smaller or no Derivative gain. See "PID tuning in Position Mode" on page 148.

Loop Error Detection and Protection

The controller will detect large tracking errors due to mechanical or sensor failures, and shut down the motor in case of problem in closed loop speed or position system. The detection mechanism looks for the size of the tracking error (desired position vs. actual position) and the duration the error is present. Three levels of sensitivity are provided in the controller configuration:

- 1: 250ms and Error > 100
- 2: 500ms and Error > 250
- 3: 1000ms and Error > 500

When an error is triggered, the motor channel is stopped until the error has disappeared, the motor channel is reset to open loop mode. The error will also be cleared when sending a new Position Destination using the !P command

The loop error can be monitored in real time using the Roborun PC utility.

SECTION 13

Closed Loop Torque Mode

This section describes the controller's operation in Torque Mode.

Torque Mode Description

The torque mode is a special case of closed loop operation where the motor command controls the current that flows through the motor regardless of the motor's actual speed.

In an electric motor, the torque is directly related to the current. Therefore, controlling the current controls the torque.

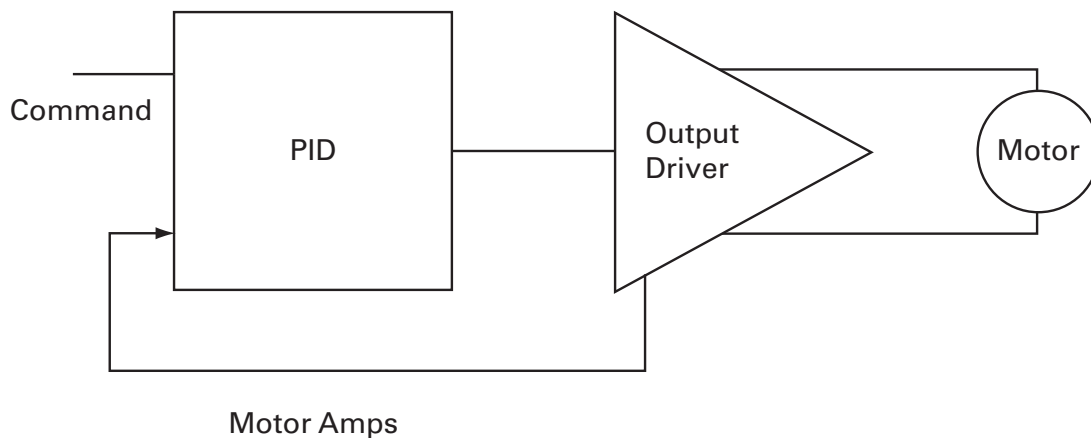

FIGURE 13-1. Torque mode

Torque mode is mostly used in electric vehicles since applying a higher command gives more "push"; similarly to how a gas engine would respond to stepping on a pedal. Likewise, releasing the throttle will cause the controller to adjust the power output so that the zero amps flow through the motor. In this case, the motor will coast and it will take a negative command (i.e. negative amps) to brake the motor to a full stop.

Torque Mode Selection, Configuration and Operation

Use the PC utility and the menu "Operating Mode" to select Torque Mode. The controller will now use user commands from RS232, RS485, TCP, USB, Analog or Pulse to command the motor current.

Torque commands can be given:

- **G** command, with range -1000 to +1000. The command for brushed controllers is then scaled using the amps limit configuration value. For example, if the amps limit is set to 100A, a user command of 500 will cause the controller to energize the motor until 50A are measured. For brushless controllers and in sinusoidal mode, the G command is scaled based on the torque (quadrature) amps limit. If flux amps are always at 0 (no field weakening) then the scaling is the same.
- **TC** command, which is similar to G command but the command is given in Nm*100. The torque constant TNM is used in order to translate the torque command to current command.
- **GIQ** command (applicable only for brushless motor controller and sinusoidal mode), with which one can give the Torque (quadrature) amps command in Amps*10.
- **GID** command (applicable only for brushless motor controller and sinusoidal mode), with which one can give the Flux amps command in Amps*10.

Torque Mode Tuning

In Torque Mode, the measured Motor Amps become the feedback in the closed loop system. The PID then operates the same way as in the other Closed Loop modes described in this manual (See "PID tuning in Position Mode" on page 148).

In most applications requiring torque mode, the loop response does not need to be very quick and good results can be achieved with a wide range of PID gains. The P and I gains are the primary component of the loop in this mode. Perform the first test using P=0, I=1 and D=0, and then adjust the I and P gain as needed until satisfactory results are reached. In brushless controllers, torque mode uses the PID that is regulating the Field Oriented Control. The gains must be therefore set in the FOC menus. See also the KIF and KPF configuration commands in the Commands Reference section.

Configuring the Loop Error Detection

In Torque Mode, it is very likely that the controller will encounter a situation where the motor is not sufficiently loaded in order to reach the desired amps. In this case, controller output will quickly rise to 100% while a significant Loop Error (i.e. desired amps - measured amps) is present. In the default configuration, the controller will shut down the power if a large loop error is present for more than a preset amount of time. This safety feature should be disabled in most systems using Torque Mode.

Speed Limiting in Brushless controllers

Brushless Controllers provide a way of smoothly limiting the speed in torque mode to prevent motor runaways. The method for limiting the speed is based on PID speed override control which provides very smooth motor output but requires PID tuning.

Therefore for the torque loop we use the Torque Proportional Gain (KPF) and the Torque Integral Gain (KIF), in FOC parameters (for both sinusoidal and trapezoidal modes), and the speed limit is tuned using the Proportional Gain (KP), the Integral Gain (KI) and the Differential Gain (KD), in Closed loop parameters. The speed loop PID tuning can either be done in "Closed Loop Torque Mode" at the speed limit or in "Closed Loop Speed Mode" by looking at the response time.

Torque Mode Limitations

The torque mode uses the Motor Amps and not the Battery Amps. See "Battery Current vs. Motor Current" on page 28. In some Roboteq controllers, Battery Amps is measured and Motor Amps is estimated. The estimation is fairly accurate at power level of 20% and higher. Its accuracy drops below 20% of PWM output and no motor current is measured at all when the power output level is 0%, even though current may be flowing in the motor, as it would be the case if the motor is pushed. The torque mode will therefore not operate with good precision at low power output levels.

Furthermore the resolution of the amps capture is limited to around 0.5% of the full range. On high current controller models, for example, amps are measured with 500mA increments. If the amps limit is set to 100A, this means the torque will be adjustable with a 0.5% resolution. If on the same large controller the amps limit is changed to 10A, the torque will be adjustable with the same 500mA granularity which will result in 5% resolution. For best results use an amps limit that is at least 50% than the controller's max rating. On newer Brushless motor controllers, amps sensors are placed at the motor output and motor amps are measured directly. Torque mode will work effectively on these models.

Torque Mode Using an External Amps Sensor

The limitations described above can be circumvented using an external amps sensor device such as the Allegro Microsystems ACS756 family of hall sensors. These inexpensive devices can be inserted in series with one of the motor leads while connected to one of the controller's analog inputs. Since it is directly measuring the real motor amps, this sensor will provide accurate current information in all load and regeneration conditions. This technique only works for DC brushed motors. On brushless motors, the current in the motor wires is AC and therefore an external sensor cannot be used.

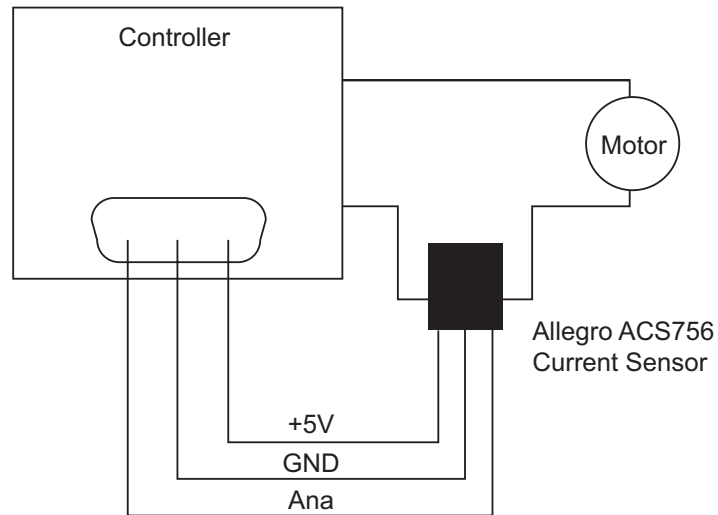

FIGURE 13-2. Torque external sensor

To operate in torque mode, simply configure the selected analog input range to this of the sensor's output at the min and max current that will correspond to the -1000 to +1000 command range. Configure the analog input as feedback for the selected motor channel. Then operate the controller in Position Tracking Mode (See "Position Tracking Mode" on page 141). While the controller will not actually be tracking position, it will adjust the output based on the command and sensor feedback exactly in the same fashion.

SECTION 14

Serial (RS232/ RS485/USB/TCP) Operation

This section describes how to communicate to the controller via the RS232, RS485, USB or TCP Interface. This information is useful if you plan to write your own controlling software on a PC or microcomputer.

The full set of commands accepted by the controller is provided in “Commands Reference” on page 169.

If you wish to use your PC simply to set configuration parameters and/or to exercise the controller, you should use the RoborunPlus PC utility.

Use and benefits of Serial Communication

The serial communication allows the controller to be connected to PCs, PLC, microcomputers or wireless modems. This connection can be used to both send commands and read various status information in real-time from the controller. The serial mode enables the design of complex motion control system, autonomous robots or more sophisticated remote controlled robots than is possible using the RC mode. RS232 and RS485 commands are very precise and securely acknowledged by the controller. They are also the method by which the controller’s features can be accessed and operated to their fullest extent.

When operating in RC or analog input, serial communication can still be used for monitoring or telemetry.

When connecting the controller to a PC, the serial mode makes it easy to perform simple diagnostics and tests, including:

- Sending precise commands to the motor
- Reading the current consumption values and other parameters
- Obtaining the controller’s software revision and date
- Reading inputs and activating outputs
- Setting the programmable parameters with a user-friendly graphical interface
- Updating the controller’s software

Serial Port Configuration

The controller's default serial communication port is set as follows:

- 115200 bits/s
- 8-bit data
- 1 Start bit
- 1 Stop bit
- No Parity

Communication is done without flow control, meaning that the controller is always ready to receive data and can send data at any time.

Connector RS232 Pin Assignment

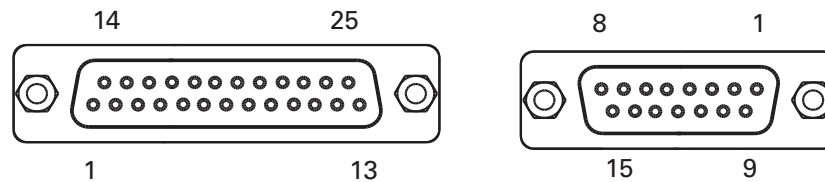

FIGURE 14-1. DB25 and DB15 connectors pin code locations

When used in the RS232 mode, the pins on the controller's DB15 or DB25 connector (depending on the controller model) are mapped as described in the table below

TABLE 14-1. RS232 Signals on DB15 and DB25 connectors §

Pin Number	Input or Output	Signal	Description
2	Output	Data Out	RS232 Data from Controller to PC
3	Input	Data In	RS232 Data In from PC
5	-	Ground	Controller ground

Connector RS485 Pin Assignment

When used in the RS485 mode, the pins on the controller's DB15, DB25 or DB9 connector (depending on the controller model) are mapped as described in each controller's datasheet.

Setting Different Bit Rates

It is possible to set RS232 and RS485 bit rate to lower values. This operation cannot be done while the controller is connected via RS232 or RS485. Beware that once the bit rate is different than the default 115200, it will no longer be able to communicate with the PC utility if serial connection is used. From the Console, send the following commands:

```
^RSBR nn
```

where nn =

- 0: 115200
- 1: 57600
- 2: 38400
- 3: 19200
- 4: 9600

Make sure that the controller respond to this command with a +. Check that the value has been accepted by sending ~RSBR.

Send %EESAV from the console to store the new configuration to flash.

Cable configuration

The RS232 connection requires the special cabling as described in Figure 14-2. The 9-pin female connector plugs into the PC (or other microcontroller). The 15-pin or 25-pin male connector plugs into the controller.

It is critical that you do not confuse the connector's pin numbering. The pin numbers on the drawing are based on viewing the connectors from the front. Most connectors brands have pin numbers molded on the plastic.

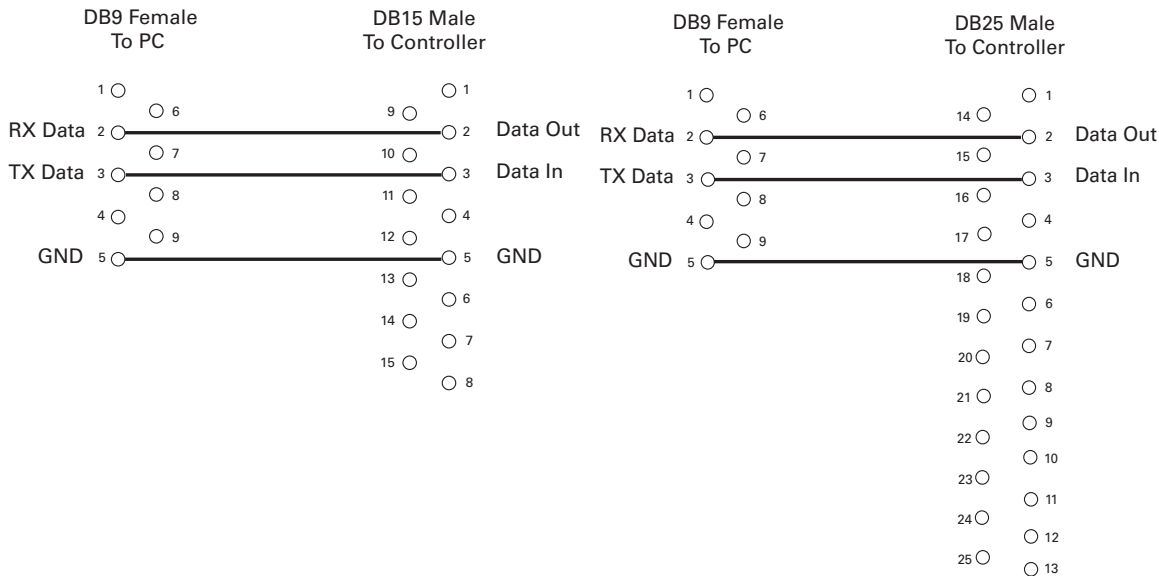

FIGURE 14-2. PC to controller RS 232 cable/connector wiring diagram

The 9 pin to 15 pin cable is provided by Roboteq for controllers with 15 pin connectors.

Controllers with 25 pins connectors are fitted with a USB port that can be used with any USB cables with a type B connector.

Extending the RS232 Cable

RS232 extension cables are available at most computer stores. However, you can easily build one using a 9-pin DB9 male connector, a 9-pin DB9 female connector and any 3-conductor cable. **DO NOT USE COMMERCIAL 9-PIN TO 25-PIN CONVERTERS** as these do not match the 25-pin pinout of the controller. These components are available at any electronics distributor. A CAT5 network cable is recommended, and cable length may be up to 100' (30m). Figure 14-3 shows the wiring diagram of the extension cable.

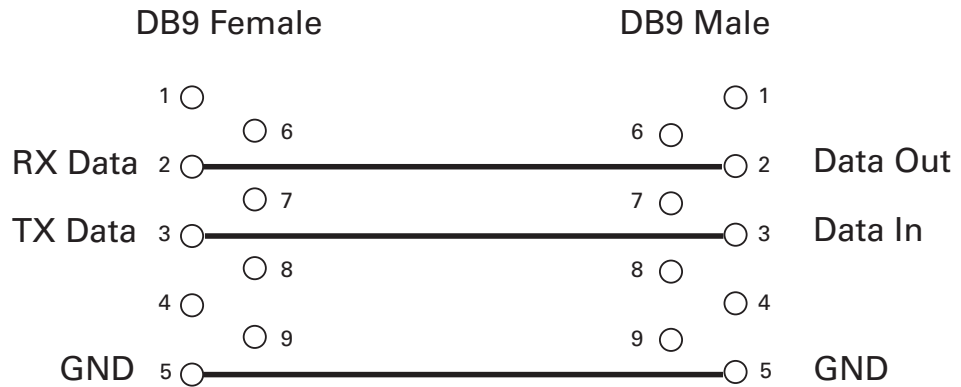

FIGURE 14-3. RS232 extension cable/connector wiring diagram

Connecting to Arduino and other TTL Serial Microcomputers

Arduino and similar microcomputers have a TTL serial port. There are Roboteq controllers supporting RS485, so the connection can be done directly. However, for the rest of the controllers there is a full RS232 serial interface. RS232 has the following differences from TTL serial:

	RS232	TTL Serial
Voltage Levels	+10V/-10V	0-3V
Logic level	Inverted	Non-Inverted

A TTL to RS232 adapter must therefore be used to convert to the Arduino serial interface. Newer Roboteq controller allows the RS232 signal to be non-inverted. Interfacing to Arduino or other TTL Serial interface can therefore be done with just a resistors, and 2 optional diodes as shown in the diagram below:

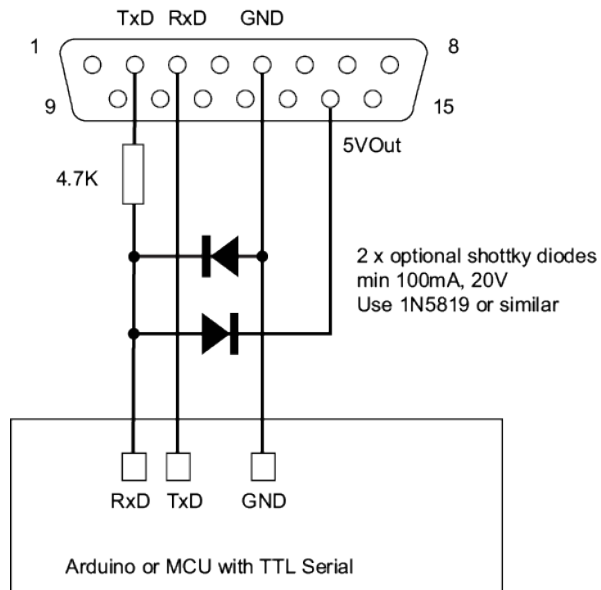

FIGURE 14-4. Simplified TTL to RS232 connection

The data sent from the TTL serial port are 0-3V and can be directly connected to the controller's RS232 input where it will be captured as valid 0-1 levels.

The data at the output of the controller is +/-10V. At the other end of the resistor, the voltage is clamped to around 0-3.3V by the protection diodes that are included in the Arduino MCU. However, to avoid any stress it is highly recommended to insert the 2 diodes shown on the diagram.

To operate, the RS232 output must be set to inverted. This must be done from the Console of the Roborun Utility while connected via USB. This will only work on newer controller models fitted with firmware version 1.6a or more recent.

From the Console, send the following commands:

```
^RSBR nn
```

where nn =

```
5: 115200 + Inverted RS232  
6: 57600 + Inverted RS232  
7: 38400 + Inverted RS232  
8: 19200 + Inverted RS232  
9: 9600 + Inverted RS232
```

Make sure that the controller respond to this command with a +. Check that the value has been accepted by sending ~RSBR. If a - is replied or if the value is different than the one entered, then the hardware and/or firmware does not support serial inverted and cannot be used with this circuit.

Send %EESAV from the console to store the new configuration to flash.

RS485 Configuration

Consult your controller's datasheet in order to know whether RS485 communication is supported. There are controller models whose pins related to RS485 communication are shared with other functionalities (check the controller's datasheet). For this reason for these controllers only, the RS485 functionality is by default disabled. In order to enable it the RS485 configuration command (RS485 enable) should be set to 1 (^RS485 1).

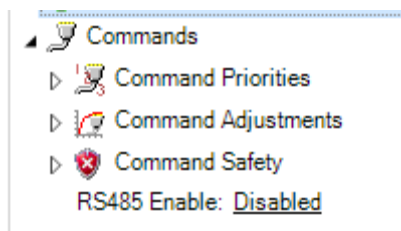

USB Configuration

USB is available on all Roboteq controller models and provides a fast and reliable communication method between the controller and the PC. After plugging the USB cable to the controller and the PC, the PC will detect the new hardware, and install the driver. Upon successful installation, the controller will be ready to use.

The controller will appear like another Serial device to the PC. This method was selected because of its simplicity, particularly when writing custom software: opening a COM port and exchanging serial data is a well documented technique in any programming language.

Note that Windows will assign a COM port number that is more or less random. The Roborun PC utility automatically scans all open COM ports and will detect the controller on its own. When writing your own software, you will need to account for this uncertainty in the COM port assignment.

Important Warning

Beware that because of its sophistication, the USB protocol is less likely to recover than RS232 should an electrical disturbance occur. We recommend using USB for configuration and monitoring, and use RS232 for field deployment. Deploy USB based system only after performing extensive testing and verifying that it operates reliably in your particular environment.

TCP Configuration

Controller models that support communication via an Ethernet cable are identified with the letter E, for example, FBL2360E or FBL2360ES. By default, TCP communication is disabled on controllers, so in order to use this feature configuration is needed. All configuration parameters may be accessed under the Roborun+ Configuration tab. All TCP parameters are configurable from the TCP node under the Inputs/Outputs Column. Find more details in section 19, "TCP Communication Commands".

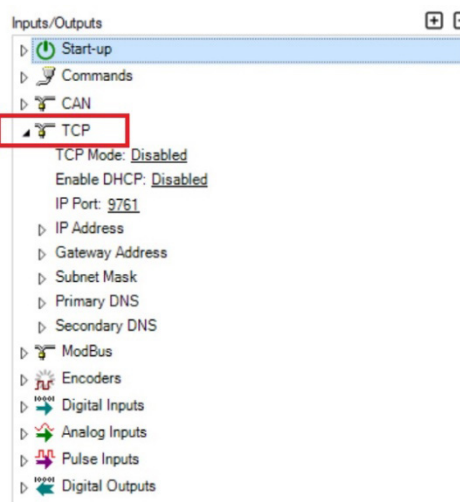

All TCP/IP configuration changes will be applied within one second after activation and communication via TCP, Modbus TCP or Modbus TCP over RTU will be available as long as the TCP mode is enabled.

Command Priorities

The controller will respond to commands from one of five possible sources:

- CAN or Script Command
- Serial (RS232, RS485, TCP or USB)
- Pulse
- Analog
- Spektrum Radio (when available)

One, two, three or four (except from CAN or Script command, which is always enabled) command modes can be enabled at the same time. When multiple modes are enabled, the controller will select which mode to use based on a user selectable priority scheme. The priority mechanism is described in details in “Input Command Modes and Priorities” on page 73.

Communication Arbitration

Commands may arrive through the RS232, RS485, TCP or the USB port at the same time. They are executed as they arrive in a first come first served manner. Commands that are arriving via USB are replied on USB. Commands arriving via the UART are replied on the UART. Redirection symbol for redirecting outputs to the other port exists (e.g. a command can be made respond on USB even though it arrived on RS232).

CAN Commands

Commands arriving via CAN have bigger priority than serial commands and will not conflict with motor command arriving via serial, TCP or USB. CAN commands are also subject to the serial Watchdog timer. Motors will be stopped and command input will switch according to the Priority table if the Watchdog timer is allowed to timeout.

Script-generated Commands

Commands that are issued from a user script have bigger priority than serial and CAN commands and will not conflict with motor command arriving via serial, TCP, USB or CAN. Script commands are also subject to the serial Watchdog timer. Motors will be stopped and command input will switch according to the Priority table if the Watchdog timer is allowed to timeout.

Communication Protocol Description

The controller uses a simple communication protocol based on ASCII characters. Commands are not case sensitive. **?a** is the same as **?A**. Commands are terminated by carriage return (Hex 0x0d, ‘\r’).

The underscore '_' character is interpreted by the controller as a carriage return. This alternate character is provided so that multiple commands can be easily concatenated inside a single string.

All other characters lower than 0x20 (space) have no effect.

Character Echo

The controller will echo back to the PC or Microcontroller every valid character it has received. If no echo is received, one of the following is occurring:

- echo has been disabled
- the controller is Off
- the controller may be defective

Command Acknowledgment

The controller will acknowledge commands in one of the two ways:

For commands that cause a reply, such as a configuration read or a speed or amps queries, the reply to the query must be considered as the command acknowledgment.

For commands where no reply is expected, such as speed setting, the controller will issue a "plus" character (+) followed by a Carriage Return after every command as an acknowledgment.

Command Error

If a command or query has been received, but is not recognized or accepted for any reason, the controller will issue a "minus" character (-) to indicate the error.

If the controller issues the "-" character, it should be assumed that the command was not recognized or lost and that it should be repeated.

Watchdog time-out

For applications demanding the highest operating safety, the controller should be configured to automatically switch to another command mode or to stop the motor (but otherwise remain fully active) if it fails to receive a valid command on its RS232, RS485, TCP, USB or CAN ports, or from a MicroBasic Script for more than a predefined period.

By default, the watchdog is enabled with a timeout period of 1 second. Timeout period can be changed or the watchdog can be disabled by the user. When the watchdog is enabled and timeout expires, the controller will accept commands from the next source in the priority list. See Command Priorities on page 167.

Controller Present Check

The controller will reply with an ASCII ACK character (0x06) anytime it receives a QRY character (0x05). This feature can be used to quickly scan a serial port and detect the presence, absence or disappearance of the controller. The QRY character can be sent at any time (even in the middle of a command) and has no effect at all on the controller's normal operation.

Commands Reference

This section lists all the commands accepted by the controller. Commands are typically sent via the serial (RS232, RS485, TCP or USB) ports (See “Serial (RS232/RS485/TCP/USB) Operation” on page 161) Except for a few maintenance commands, they can also be issued from within a user script written using the MicroBasic language (See “MicroBasic Scripting Manual”).

Commands Types

The controller will accept and recognize four types of commands:

Runtime commands

These start with “!” when called via the serial communication (RS232, RS485, TCP or USB), or using the setcommand() MicroBasic function. These are usually motor or operation commands that will have immediate effect (e.g. to turn on the motor, set a speed or activate digital output). Most of Runtime commands are mapped inside a CANopen Object Directory, allowing the controller to be remotely operated on a CANopen standard network (See “CAN Networking Manual”). See “Runtime Commands” on page 169 for the full list and description of these commands.

Runtime queries

These start with “?” when called via the serial communication (RS232, RS485, TCP or USB), or using the getvalue() Microbasic function. These are used to read operating values at runtime (e.g. read Amps, Volts, power level, counter values). All runtime queries are mapped inside a CANopen Object Directory, allowing the controller to be remotely interrogated on a CANopen standard network (See “CAN Networking Manual”). See Runtime commands are commands that can be sent at any time during controller operation and are taken into consideration immediately. Runtime commands start with “!” and are followed by one to three letters. Runtime commands are also used to refresh the watchdog timer to ensure safe communication. Runtime commands can be called from a MicroBasic script using the setcommand() function..

Maintenance commands

These are only available trough serial (RS232, RS485, TCP or USB) and start with “%”. They are used for all of the maintenance commands such as (e.g. set the time, save configuration to EEPROM, reset, load default, etc.).

Configuration commands

These start with “~” for read and “^” for write when called via the serial communication (RS232, RS485, TCP or USB), or using the getConfig() and setConfig() MicroBasic functions. They are used to read or configure all the operating parameters of the controller (e.g. set or read amps limit). See “Set/Read Configuration Commands” on page 259 for the full list and description of these commands.

Runtime Commands

Runtime commands are commands that can be sent at any time during controller operation and are taken into consideration immediately. Runtime commands start with “!” and are followed by one to three letters. Runtime commands are also used to refresh the watchdog timer to ensure safe communication. Runtime commands can be called from a MicroBasic script using the setCommand() function.

TABLE 15-1. Runtime Commands

Command	Arguments	Description
AC	Channel Acceleration	Set Acceleration
AX	Channel Acceleration	Next Acceleration
B	VarNbr Value	Set User Boolean Variable
BND	None	Spectrum Bind
C	Channel Value	Set Encoder Counters
CB	Channel Value	Set Brushless Counter
CG	Channel Value	Set Motor Command via CAN
CS	Element Value	CAN Send
CSS	Channel Value	Set SSI Sensor Counter
D0	OutputNbr	Reset Individual Digital Out bits
D1	OutputNbr	Set Individual Digital Out bits
DC	Channel Deceleration	Set Deceleration
DS	Value	Set all Digital Out bits
DX	Channel Value	Next Deceleration
EES	None	Save Configuration in EEPROM
EX	None	Emergency Shutdown
G	Channel Value	Go to Speed or to Relative Position
GIQ	Channel Value	Go to Torque Amps
GID	Channel Value	Go to Flux Amps
H	Channel	Load Home counter
MG	None	Emergency Stop Release
MS	Channel	Stop in all modes
P	Channel Destination	Go to Absolute Desired Position
PR	Channel Delta	Go to Relative Desired Position
PRX	Channel Delta	Next Go to Relative Desired Position
PX	Channel Delta	Next Go to Absolute Desired Position
R	[Option]	MicroBasic Run

Command	Arguments	Description
RC	Channel Value	Set Pulse Out
S	Channel Value	Set Motor Speed
STT	None	STO Self-Test
SX	Channel Value	Next Velocity
VAR	VarNbr Value	Set User Variable

AC - Set Acceleration

Alias: ACCEL

HexCode: 07

CANOpen id: 0x2006

Description:

Set the rate of speed change during acceleration for a motor channel. This command is identical to the MACC configuration command but is provided so that it can be changed rapidly during motor operation. Acceleration value is in 0.1 * RPM per second. When using controllers fitted with encoder, the speed and acceleration value are actual RPMs. Brushless motor controllers use the hall sensor for measuring actual speed and acceleration will also be in actual RPM/s. When using the controller without speed sensor, the acceleration value is relative to the Max RPM configuration parameter, which itself is a user-provided number for the speed normally expected at full power. Assuming that the Max RPM parameter is set to 1000, and acceleration value of 10000 means that the motor will go from 0 to full speed in exactly 1 second, regardless of the actual motor speed. In Closed Loop Torque mode acceleration value is in 0.1 * milliAmps per second. This command is not applicable if either of the acceleration (MAC) or deceleration (MDEC) configuration value is set to 0.

Syntax Serial: !AC cc nn

Syntax Scripting: setcommand(_AC, cc, nn)
setcommand(_ACCEL, cc, nn)

Number of Arguments: 2

Argument 1: Channel
Min: 1 Max: Total Number of Motors

Argument 2: Acceleration Type: Signed 32-bit
Min: 0 Max: 500000

Where:

cc = Motor channel

nn = Acceleration value in 0.1 * RPM/s

Example:

!AC 1 2000 : Increase Motor 1 speed by 200 RPM every second if speed is measured by encoder

!AC 2 20000 : Time from 0 to full power is 0.5s if no speed sensors are present and Max RPM is set to 1000

AX - Next Acceleration

Alias: NXTACC

HexCode: 14

CANOpen id: 0x2012

Description:

This command is used for chaining commands in Position Count mode. It is similar to AC except that it stores an acceleration value in a buffer. This value will become the next acceleration the controller will use and becomes active upon reaching a previous desired position. If omitted, the command will be chained using the last used acceleration value. This command is not applicable if either of the acceleration (MAC) or deceleration (MDEC) configuration value is set to 0.

Syntax Serial: !AX cc nn

Syntax Scripting: setcommand(_AX, cc, nn)
setcommand(_NXTACC, cc, nn)

Number of Arguments: 2

Argument 1: Channel

Min: 1 Max: Total Number of Motors

Argument 2: Acceleration Type: Signed 32-bit

Min: 0 Max: 500000

Where:

cc = Motor channel

nn = Acceleration value in 0.1 * RPM/s

B - Set User Boolean Variable

Alias: BOOL

HexCode: 16

CANOpen id: 0x2015

Description:

Set the state of user boolean variables inside the controller. These variables can then be read from within a user MicroBasic script to perform specific actions.

Syntax Serial: !B nn mm

Syntax Scripting: setcommand(_B, nn, mm)
setcommand(_BOOL, nn, mm)

Number of Arguments: 2

Argument 1: VarNbr

Min: 1 Max: Total nbr of Bool Vars

Argument 2: Value Type: Boolean

Min: 0 Max: 1

Where:

nn = Variable number

mm = 0 or 1

Note:

The total number of user variables depends on the controller model and can be found in the product datasheet.

BND - Spectrum Bind

Alias: BIND

HexCode: 1C

CANOpen id:

Description:

When used on controllers with Spektrum RC radio interface the BND command is used to pair the receiver with its transmitter.

Syntax Serial: !BND [cc]

Syntax Scripting: setcommand(_BND, cc)
setcommand(_BIND, cc)

Number of Arguments: 1

Argument 1: [Channel] Type: Unsigned 8-bit

Min: None

Max: Total Number of Motors

Where:

cc = Motor channel

Example:

!BND : Binds Spektrum receiver with its transmitter, on supporting controller models

C - Set Encoder Counters

Alias: SENCNTR

HexCode: 04

CANOpen id: 0x2003

Description:

This command loads the encoder counter for the selected motor channel with the value contained in the command argument. Beware that changing the controller value while operating in closed-loop mode can have adverse effects.

Syntax Serial: !C [cc] nn

Syntax Scripting: setcommand(_C, cc, nn)
setcommand(_SENCNTR, cc, nn)

Number of Arguments: 2

Argument 1: Channel

Min: 1 Max: Total Number of Encoders

Argument 2: Value Type: Signed 32-bit
Min: -2147M Max: +2147M

Where:

cc = Motor channel
nn = Counter value

Example:

!C 2 -1000 : Loads -1000 in encoder counter 2
!C 1 0 : Clears encoder counter 1

CB - Set Brushless Counter

Alias: SBLCNTR HexCode: 05 CANOpen id: 0x2004

Description:

This command loads the brushless counter with the value contained in the command argument. Beware that changing the controller value while operating in closed-loop mode can have adverse effects.

Syntax Serial: !CB [cc] nn

Syntax Scripting: setcommand(_CB, cc, nn)
 setcommand(_SBLCNTR, cc, nn)

Number of Arguments: 2

Argument 1: Channel

Min: 1 Max: Total Number of Motors

Argument 2: Value Type: Signed 32-bit
Min: -2147M Max: +2147M

Where:

cc = Motor channel
nn = Counter value

Example:

!CB 1 -1000 : Loads -1000 in brushless counter 1
!CB 2 0 : Clears brushless counter 2

CG - Set Motor Command via CAN

Alias: CANGO HexCode: 19 CANOpen id: 0x2000

Description:

This command is identical to the G (GO) command except that it is meant to be used for sending motor commands via CANOpen. See the G command for details

Syntax Serial: !CG cc nn

Syntax Scripting: setcommand(_CG, cc, nn)
setcommand(_CANGO, cc, nn)

Number of Arguments: 2

Argument 1: Channel

Min: 1 Max: Total Number of Motors

Argument 2: Value Type: Signed 32-bit

Min: -1000 Max: +1000

Where:

cc = Motor channel

nn = Command value

CS - CAN Send

Alias: CANSEND

HexCode: 18

CANOpen id:

Description:

This command is used in CAN-enabled controllers to build and send CAN frames in the RawCAN mode (See RawCAN section in manual). It can be used to enter the header, bytecount, and data, one element at a time. The frame is sent immediately after the bytecount is entered, and so it should be entered last.

Syntax Serial: !CS ee nn

Syntax Scripting: setcommand(_CS, ee, nn)
setcommand(_CANSEND, ee, nn)

Number of Arguments: 2

Argument 1: Element

Min: 1 Max: 10

Argument 2: Value Type: Unsigned 8-bit

Min: 0 Max: 255

Where:

ee =

1 : Header

2 : Bytecount

3 to 10 : Data0 to data7

nn = value

Example:

!CS 1 5 : Enter 5 in header

!CS 3 2 : Enter 2 in data 0

!CS 4 3 : Enter 3 in data 1

!CS 2 2 : Enter 2 in bytecount and send CAN frame

CSS - Set SSI Sensor Counter

Alias: - HexCode: 6C CANOpen id: 0x201F

Description:

This command loads the SSI Sensor counter with the value contained in the command argument. Beware that changing the controller value while operating in closed-loop mode can have adverse effects. This command is not applicable if the respective sensor's use has been set as absolute feedback.

Syntax Serial: !CSS [cc] nn

Syntax Scripting: setcommand(_CSS, cc, nn)

Number of Arguments: 2

Argument 1: Channel

Min: 1 Max: Total Number of SSI sensors

Argument 2: Value Type: Signed 32-bit

Min: -2147M Max: +2147M

Where:

cc = SSI sensor channel

nn = Counter value

Example:

!CSS 1 -1000 : Loads -1000 in SSI sensor counter 1

!CSS 2 0 : Clears SSI sensor counter 2

D0 - Reset Individual Digital Out bits

Alias: DRES HexCode: 09 CANOpen id: 0x200A

Description:

The D0 command will turn off the single digital output selected by the number that follows.

Syntax Serial: !D0 nn

Syntax Scripting: setcommand(_D0, nn)
setcommand(_DRES, nn)

Number of Arguments: 1

Argument 1: OutputNbr Type: Unsigned 8-bit

Min: 1 Max: Total number of Digital Outs

Where:

nn = Output number

Example:

!D0 2 : will deactivate output 2

Note:

Digital Outputs are Open Collector. Activating an outputs will force it to ground. Deactivating an output will cause it to float.

D1 - Set Individual Digital Out bits

Alias: DSET

HexCode: 0A

CANOpen id: 0x2009

Description:

The D1 command will activate the single digital output that is selected by the parameter that follows.

Syntax Serial: !D1 nn

Syntax Scripting: `setcommand(_D1, nn)`
`setcommand(_DSET, nn)`

Number of Arguments: 1

Argument 1: OutputNbr Type: Unsigned 8-bit

Min: 1 Max: Total number of Digital Outs

Where:

nn = Output number

Example:

!D1 1 : will activate output 1

Note:

Digital Outputs are Open Collector. Activating an outputs will force it to ground. Deactivating an output will cause it to float.

DC - Set Deceleration

Alias: DECEL

HexCode: 08

CANOpen id: 0x2007

Description:

Set the rate of speed change during deceleration for a motor channel. This command is identical to the MDEC configuration command but is provided so that it can be changed rapidly during motor operation. Deceleration value is in $0.1 * \text{RPM per second}$. When using controllers fitted with encoder, the speed and deceleration value are actual RPMs. Brushless motor controllers use the hall sensor for measuring actual speed and deceleration will also be in actual RPM/s. When using the controller without speed sensor, the deceleration value is relative to the Max RPM configuration parameter, which itself is a user-provided number for the speed normally expected at full power. Assuming that the Max RPM parameter is set to 1000, and deceleration value of 10000 means that the motor will go from full speed to 0 in exactly 1 second, regardless of the actual motor speed. In Closed Loop Torque mode deceleration value is in $0.1 * \text{miliAmps per second}$. This command is not applicable if either of the acceleration (MAC) or deceleration (MDEC) configuration value is set to 0.

Syntax Serial: !DC cc nn

Syntax Scripting: setcommand(_DC, cc, nn)
setcommand(_DECEL, cc, nn)

Number of Arguments: 2

Argument 1: Channel

Min: 1 Max: Total Number of Motors

Argument 2: Deceleration Type: Signed 32-bit

Min: 0 Max: 500000

Where:

cc = Motor channel

nn = Deceleration value in 0.1 * RPM/s

Example:

!DC 1 2000 : Reduce Motor 1 speed by 200 RPM every second if speed is measured by encoder

!DC 2 20000 : Time from full power to stop is 0.5s if no speed sensors are present and Max RPM is set to 1000

DS - Set all Digital Out bits

Alias: DOUT

HexCode: 09

CANOpen id: 0x2008

Description:

The D command will turn ON or OFF one or many digital outputs at the same time. The number can be a value from 0 to 255 and binary representation of that number has 1bit affected to its respective output pin.

Syntax Serial: !DS nn

Syntax Scripting: setcommand(_DS, nn)
setcommand(_DOUT, nn)

Number of Arguments: 1

Argument 1: Value Type: Unsigned 8-bit

Min: 0 Max: 255

Where:

nn = Bit pattern to be applied to all output lines at once

Example:

!DS 03 : will activate outputs 1 and 2. All others are off

Note:

Digital Outputs are Open Collector. Activating an outputs will force it to ground. Deactivating an output will cause it to float.

DX - Next Deceleration

Alias: NXTDEC

HexCode: 15

CANOpen id: 0x2013

Description:

This command is used for chaining commands in Position Count mode. It is similar to DC except that it stores a deceleration value in a buffer. This value will become the next deceleration the controller will use and becomes active upon reaching a previous desired position. If omitted, the command will be chained using the last used deceleration value. This command is not applicable if either of the acceleration (MAC) or deceleration (MDEC) configuration values is set to 0 (bypass command ramp).

Syntax Serial: !DX cc nn

Syntax Scripting: `setcommand(_DX, cc, nn)`
`setcommand(_NXTDEC, cc, nn)`

Number of Arguments: 2

Argument 1: Channel

Min: 1 Max: Total Number of Motors

Argument 2: Value Type: Signed 32-bit

Min: 0 Max: 500000

Where:

cc = Motor channel

nn = Acceleration value

EES - Save Configuration in EEPROM

Alias: EESAV

HexCode: 1B

CANOpen id: 0x2017

Description:

This command causes any changes to the controller's configuration to be saved to Flash. Saved configurations are then loaded again next time the controller is powered on. This command is a duplication of the EESAV maintenance command. It is provided as a Real-Time command as well in order to make it possible to save configuration changes from within MicroBasic scripts.

Syntax Serial: !EES

Syntax Scripting: `setcommand(_EES, 1)`
`setcommand(_EESAV, 1)`

Number of Arguments: 0

Note:

Do not save configuration while motors are running. Saving to EEPROM takes several milliseconds, during which the control loop is suspended. Number of EEPROM write cycles are limited to around 10000. Saving to EEPROM must be done scarcely.

EX - Emergency Stop

Alias: ESTOP

HexCode: 0E

CANOpen id: 0x200C

Description:

The EX command will cause the controller to enter an emergency stop in the same way as if hardware emergency stop was detected on an input pin. The emergency stop condition will remain until controller is reset or until the MG release command is received.

Syntax Serial: !EX

Syntax Scripting: setcommand(_EX, 1)
setcommand(_ESTOP, 1)

Number of Arguments: 0

G - Go to Speed or to Relative Position

Alias: GO

HexCode: 00

CANOpen id: Use CG

Description:

G is the main command for activating the motors. The command is a number ranging 1000 to +1000 so that the controller respond the same way as when commanded using Analog or Pulse, which are also -1000 to +1000 commands. The effect of the command differs from one operating mode to another.

In Open Loop Speed mode the command value is the desired power output level to be applied to the motor.

In Closed Loop Speed mode, the command value is relative to the maximum speed that is stored in the MXRPM configuration parameter.

In Closed Loop Position Relative and in the Closed Loop Tracking mode, the command is the desired relative destination position mode.

The G command has no effect in the Position Count mode.

In Torque mode, the command value is the desired Motor Amps relative to the Amps Limit configuration parameters

Syntax Serial: !G [nn] mm

Syntax Scripting: setcommand(_G, nn, mm)
setcommand(_GO, nn, mm)

Number of Arguments: 2

Argument 1: Channel

Min: 1 Max: Total Number of Motors

Argument 2: Value

Type: Signed 32-bit

Min: -1000

Max: 1000

Where:

cc = Motor channel
nn = Command value

Example:

!G 1 500 : In Open Loop Speed mode, applies 50% power to motor channel 1
!G 1 500 : In Closed Loop Speed mode, assuming that 3000 is contained in Max RPM parameter (MXRPM), motor will go to 1500 RPM
!G 1 500 : In Closed Loop Relative or Closed Loop Tracking modes, the motor will move to 75% position of the total -1000 to +1000 motion range
!G 1 500 : In Torque mode, assuming that Amps Limit is 60A, motor power will rise until 30A are measured.

GIQ - Go to Torque Amps

Alias: - HexCode: 7A CANOpen id: -

Description:

GIQ is the command for the torque amps in closed loop torque mode only for brushless controllers in sinusoidal mode. In other cases it is void. The value is set in Amps*10. After the motor stops or at power up the target flux amps is set by the TID value.

Syntax Serial: !GIQ [nn] mm

Syntax Scripting: setcommand(_GIQ, nn, mm)

Number of Arguments: 2

Argument 1: Channel

Min: 1 Max: Total Number of Motors

Argument 2: Amps

Type: Signed 32

Min: 0 Max: Max Amps in datasheet

Where:

cc = Motor channel
nn = Amps*10

Example:

!GIQ 1 500 : In Closed Loop Torque mode, applies 50,0A torque amps command.

GID - Go to Torque Amps

Alias: - HexCode: 7B CANOpen id: -

Description:

GID is the command for the flux amps in closed loop torque mode only for brushless controllers in sinusoidal mode. In other cases it is void. The value is set in Amps*10. A non-zero value creates field weakening and can be used to achieve higher rotation speed

Syntax Serial: !GID [nn] mm

Syntax Scripting: setcommand(_GID, nn, mm)

Number of Arguments: 2

Argument 1: Channel

Min: 1 Max: Total Number of Motors

Argument 2: Amps

Type: Signed 32

Min: 0 Max: Max Amps in datasheet

Where:

cc = Motor channel

nn = Amps*10

Example:

!GID 1 -200: In Closed Loop Torque mode, applies -20,0A flux amps command (field weakening).

H - Load Home counter

Alias: HOME

HexCode: 0D

CANOpen id: 0x200B

Description:

This command loads the Home count value into the Encoder, SSI Sensor, or Brushless Counters. The Home count can be any user value and is set using the EHOME, SHOME and BHOME configuration parameters. When SSI sensors are used as absolute encoders (Absolute Feedback) then this command loads to the Home count value the SSI sensor counter. In this case the Home count value is used as offset to the SSI sensor Counter. Beware that loading the counter with the home value while the controller is operating in closed loop can have adverse effects.

Syntax Serial: !H [cc]

Syntax Scripting: setcommand(_H, cc)
setcommand(_HOME, cc)

Number of Arguments: 1

Argument 1: Channel Type: Unsigned 8-bit

Min: 1 Max: Total Number of Encoders

Where:

cc = Motor channel

Example:

!H 1: Loads encoder counter 1, SSI sensor counter 1 and brushless counter 1 with their preset home values.

MG - Emergency Stop Release

Alias: MGO HexCode: 0F CANOpen id: 0x200D

Description:

The MG command will release the emergency stop condition and allow the controller to return to normal operation. Always make sure that the fault condition has been cleared before sending this command

Syntax Serial: !MG

Syntax Scripting: setcommand(_MG, 1)
 setcommand(_MGO, 1)

Number of Arguments: 0

MS - Stop in all modes

Alias: MSTOP HexCode: 10 CANOpen id: 0x200E

Description:

The MS command will stop the motor for the specified motor channel.

Syntax Serial: !MS [cc]

Syntax Scripting: setcommand(_MS, cc)
 setcommand(_MSTOP, cc)

Number of Arguments: 1

Argument 1: Channel Type: Unsigned 8-bit
 Min: 1 Max: Total Number of Motors

Where:

cc = Motor channel

P - Go to Absolute Desired Position

Alias: MOTPOS HexCode: 02 CANOpen id: 0x2001

Description:

This command is used in the Position Count mode to make the motor move to a specified feedback sensor count value.

Syntax Serial: !P [cc] nn

Syntax Scripting: `setcommand(_P, cc, nn)`
`setcommand(_MOTPOS, cc, nn)`

Number of Arguments: 2

Argument 1: Channel

Min: 1 Max: Total Number of Motors

Argument 2: Destination Type: Signed 32-bit

Min: -2147M Max: +2147M

Where:

cc = Motor channel

nn = Absolute count destination

Example:

!P 1 10000 : make motor go to absolute count value 10000.

PR - Go to Relative Desired Position

Alias: MPOSREL

HexCode: 11

CANOpen id: 0x200F

Description:

This command is used in the Position Count mode to make the motor move to a feedback sensor count position that is relative to its current desired position.

Syntax Serial: PR [cc] nn

Syntax Scripting: `setcommand(_PR, cc, nn)`
`setcommand(_MPOSREL, cc, nn)`

Number of Arguments: 2

Argument 1: Channel

Min: 1 Max: Total Number of Motors

Argument 2: Delta Type: Signed 32-bit

Min: -2147M Max: +2147M

Where:

cc = Motor channel

nn = Relative count position

Example:

!PR 1 10000 : while motor is stopped after power up and counter = 0, motor 1 will go to +10000

!PR 2 10000 : while previous command was absolute goto position !P 2 5000, motor will go to +15000

Note:

Beware that counter will rollover at counter values +/-2'147'483'648.

PRX - Next Go to Relative Desired Position

Alias: NXTPOSR HexCode: 13 CANOpen id: 0x2011

Description:

This command is similar to PR except that it stores a relative count value in a buffer. This value becomes active upon reaching a previous desired position and will become the next destination the controller will go to. See Position Command Chaining in manual.

Syntax Serial: !PRX [cc] nn

Syntax Scripting: setcommand(_PRX, cc, nn)
 setcommand(_NXTPOSR, cc, nn)

Number of Arguments: 2

Argument 1: Channel

Min: 1 Max: Total Number of Motors

Argument 2: Delta Type: Signed 32-bit

Min: -2147M Max: +2147M

Where:

cc = Motor channel

nn = Relative count position

Example:

!P 1 5000 followed by !PRX 1 -10000 : will cause motor to go to count position 5000 and upon reaching the destination move to position -5000.

PX - Next Go to Absolute Desired Position

Alias: NXTPOS HexCode: 12 CANOpen id: 0x2010

Description:

This command is similar to P except that it stores an absolute count value in a buffer. This value will become the next destination the controller will go to and becomes active upon reaching a previous desired position. See Position Command Chaining in manual.

Syntax Serial: !PX [nn] cc

Syntax Scripting: setcommand(_PX, nn, cc)
 setcommand(_NXTPOS, nn, cc)

Number of Arguments: 2

Argument 1: Channel

Min: 1 Max: Total Number of Motors

Argument 2: Delta Type: Signed 32-bit

Min: -2147M Max: +2147M

Where:

cc = Motor channel
nn = Absolute count position

Example:

!P 1 5000 followed by !PX 1 -10000 : will cause motor to go to count position 5000 and upon reaching the destination move to position -10000.

R - MicroBasic Run

Alias: BRUN HexCode: 0C CANOpen id: 0x2018

Description:

This command is used to start, stop and restart a MicroBasic script if one is loaded in the controller.

Syntax Serial: !R [nn]

Syntax Scripting: setcommand(_R, nn)
 setcommand(_BRUN, nn)

Number of Arguments: 1

Argument 1: [Option] Type: Unsigned 8-bit
 Min: None Max: 2

Where:

nn =
None : Start/resume script
0 : Stop script
1 : Start/resume script
2 : Reinitialize and restart script

RC - Set Pulse Out

Alias: RCOUT HexCode: 1A CANOpen id: 0x2016

Description:

Set the pulse width on products with pulse outputs. Command ranges from -1000 to +1000, resulting in pulse width of 1.0ms to 1.5ms respectively.

Syntax Serial: !RC cc nn

Syntax Scripting: setcommand(_RC, cc, nn)
 setcommand(_RCOUT, cc, nn)

Number of Arguments: 2

Argument 1: Channel
 Min: 1 Max: Number of Pulse Outs

Argument 2: Value Type: Signed 16-bit
 Min: -1000 Max: 1000

Where:

cc = Channel number
nn = Value

S - Set Motor Speed

Alias: MOTVEL HexCode: 03 CANOpen id: 0x2002

Description:

In the Closed-Loop Speed mode, this command will cause the motor to spin at the desired RPM speed. In Closed-Loop Position modes, this commands determines the speed at which the motor will move from one position to the next. It will not actually start the motion.

Syntax Serial: !S [cc] nn

Syntax Scripting: setcommand(_S, cc, nn)
 setcommand(_MOTVEL, cc, nn)

Number of Arguments: 2

Argument 1: Channel

Min: 1 Max: Total Number of Motors

Argument 2: Value Type: Signed 32-bit

Min:-65535 Max: 65535

Where:

cc = Motor channel
nn = Speed value in RPM

Example:

!S 2500 : set motor 1 position velocity to 2500 RPM

STT - STO Self-Test

Alias: - HexCode: 70 CANOpen id: -

Description:

With this command the STO Self-Test process is executed in order to check whether there is a fault. This process is applicable only on motor controllers with STO circuit implemented on their board. The result of the test is taken back using the STT query. In case of fault the Respective STO Fault bit in the Fault Flags is set. The fault is triggered when:

- Any of the transistors or other component of the STO circuit is damaged.
- The respective jumper is placed on the board.

Syntax Serial: !STT

Syntax Scripting: setcommand(_STT, 1)

Number of Arguments: 0

SX - Next Velocity

Alias: NXTVEL

HexCode: 17

CANOpen id: 0x2014

Description:

This command is used in Position Count mode. It is similar to S except that it stores a velocity value in a buffer. This value will become the next velocity the controller will use and becomes active upon reaching a previous desired position. If omitted, the command will be chained using the last used velocity value. See Position Command Chaining in manual.

Syntax Serial: !SX cc nn

Syntax Scripting: setcommand(_SX, cc, nn)
setcommand(_NXTVEL, cc, nn)

Number of Arguments: 2

Argument 1: Channel

Min: 1 Max: Total Number of Motors

Argument 2: Value Type: Signed 32-bit

Min: -500000 Max: 500000

Where:

cc = Motor channel

nn = Velocity value

VAR - Set User Variable

Alias: VAR

HexCode: 06

CANOpen id: 0x2005

Description:

This command is used to set the value of user variables inside the controller. These variables can be then read from within a user MicroBasic script to perform specific actions. The total number of variables depends on the controller model and can be found in the product datasheet. Variables are signed 32-bit integers.

Syntax Serial: !VAR nn mm

Syntax Scripting: setcommand(_VAR, nn, mm)
setcommand(_VAR, nn, mm)

Number of Arguments: 2

Argument 1: VarNbr

Min: 1 Max: Total nbr of User Variables

Argument 2: Value Type: Signed 32-bit

Min: -2147M Max: 2147M

Where:

nn = Variable number

mm = Value

DS402 Runtime Commands

Runtime commands created to support DS402 specification are described below:

TABLE 15-2.

Command	Arguments	Description
CW	Channel Value	Control Word (DS402)
PAC	Channel Value	Profile Acceleration (DS402)
PDC	Channel Value	Profile Deceleration (DS402)
POS	Channel Value	Target Position (DS402)
PSP	Channel Value	Profile Velocity (DS402)
ROM	Channel Value	Modes of Operation (DS402)
S	Channel Value	Target Velocity (DS402)
SAC	Element Value	Velocity Acceleration (DS402)
SDC	Element Value	Velocity Deceleration (DS402)
SPL	Element Value	Velocity Min/Max Amount (DS402)
TC	Channel Value	Target Torque (DS402)
TSL	Channel Value	Torque Slope (DS402)

CW – Control Word (DS402)

Alias: CW

HexCode: 56

CANOpen id: 0x6040

Description:

This command controls the PDS-FSA. Bits 9, 6, 5, and 4 of the ControlWord are operation mode specific. The halt function (bit 8) behavior is operation mode specific. If the bit is 1, the commanded motion shall be interrupted, after releasing the halt function, the commanded motion shall be continued if possible.

TABLE 15-3. Control Word Mapping

15		11	10	9	8	7	6	4	3	2	1	0
R		R	OMS	H	FR	OMS		EO	QS	EV	SO	
MSB											LSB	

R → Reserved, OMS → Operation mode specific, H → Halt, FR → Fault reset,
EO → Enable operation QS → Quick stop, EV → Enable voltage, and SO → Switch on

TABLE 15-4. Command Coding

Command	Bits of the Control Word					Transition
	Bit 7	Bit 3	Bit 2	Bit 1	Bit 0	
Shutdown	0	X	1	1	1	2,6,8
Switch On	0	0	1	1	1	3
Switch On + Enable Operation	0	1	1	1	1	3+4
Disable Voltage	0	X	X	0	X	7,9,10,12

Command	Bits of the Control Word					Transition
	Bit 7	Bit 3	Bit 2	Bit 1	Bit 0	
Quick Stop	0	X	0	1	X	7,10,11
Disable Operation	0	0	1	1	1	5
Enable Operation	0	1	1	1	1	4,16
Fault Reset	0->1	X	X	X	X	15

TABLE 15-5. Halt Bit (Bit 8)

Bit	Value	Definition
8	0	Positioning shall be executed or continued
	1	Axis shall be stopped. Slow down on quick stop ramp (EDEC) and stay in operation enabled

Profile Position Mode

TABLE 15-6. Control Word Mapping in Profile Position Mode

15	10	9	8	7	6	5	4	3	0
see Table 1	Change on set-point	Halt	see Table 1	Abs/rel	Change Set Immediately	New Set Point	see Table 1		
MSB					LSB				

In Profile Position Mode the operation specific bits are mapped in Table 8. With bits 4, 5 and 9, user can define when the command for next Position (0x607A - POS) will be processed. Bit 6 defines whether the command is absolute or relative to the current position.

TABLE 15-7. Definition of Bits 4, 5, 6, and 9 in Profile Position Mode

Bit 9	Bit 5	Bit 4	Definition
0	0	0->1	Positioning shall be completed (target reached) before the next one gets started.
X	1	0->1	Next positioning shall be started immediately
1	0	0->1	Positioning with the current profile velocity up to the current set-point shall be proceeded and then next positioning shall be applied
Bit	Value	Definition	
6	0	Target position shall be an absolute value	
	1	Target position shall be a relative value. Positioning moves shall be performed relative to the preceding (internal absolute) target position	

Velocity Mode

TABLE 15-8. Control Word Mapping in Velocity Mode

15	9	8	7	6	5	4	3	0
see Table 1	Halt	see Table 1	Reference Ramp	Unlock Ramp	Enable Ramp	see Table 1		
MSB					LSB			

In Velocity Mode the operation specific bits are mapped on Table 6. With bits 4, 5 and 6, user can configure the available ramp related options as shown in Table 7.

TABLE 15-9 Definition of Bits 4, 5, and 6 in Velocity Mode

Bit	Value	Definition
4	0	Motor shall be halted. Slow down on quick stop ramp (EDEC) and stay in operation enabled
	1	Velocity demand value shall accord with ramp output value
5	0	Ramp output value shall be locked to current output value
	1	Ramp output value shall follow ramp input value
6	0	Ramp input value shall be set to zero
	1	Ramp input value shall accord with ramp reference

Syntax Serial: !CW cc nn

Syntax Scripting: SetCommand(_CW, cc, nn)

Arguments: 2

Argument 1: Channel

Type: Unsigned 8-bit

Min: 1

Max: Total number of motors

Argument 2: Value

Type: Unsigned 16-bit

Where:

cc = Motor channel

nn = Control word value

PAC – Profile Acceleration (DS402)

Alias: PAC

HexCode: 5E

CANOpen id: 0x6083

Description:

This command is used to set the configured acceleration in 10×RPM/second.

Syntax Serial: !PAC cc nn

Syntax Scripting: SetCommand(_PAC, cc, nn)

Arguments: 2

Argument 1: Channel

Type: Unsigned 8-bit

Min: 1

Max: Total number of motors

Argument 2 Value

Type: Unsigned 32-bit

Where:

cc = Motor channel

nn = Profile acceleration in 10×RPM/second

PDC – Profile Deceleration (DS402)

Alias: PDC HexCode: 5F CANOpen id: 0x6084

Description:

This command is used to set the configured deceleration in 10×RPM/second.

Syntax Serial: !PDC cc nn

Syntax Scripting: SetCommand(_PDC, cc, nn)

Arguments: 2

Argument 1: Channel Type: Unsigned 8-bit

Min: 1 Max: Total number of motors

Argument 2: Value Type: Unsigned 32-bit

Where:

cc = Motor channel

nn = Profile deceleration in 10×RPM/second

POS – Target Position (DS402)

Alias: POS HexCode: 5C CANOpen id: 0x607A

Description:

This command is used to set the commanded position that the drive should move to in position profile mode using the current settings of motion control parameters such as velocity, acceleration, deceleration, motion profile type etc. The value is interpreted as absolute or relative depending on the abs/rel flag in the Control Word.

Syntax Serial !POS cc nn

Syntax Scripting SetCommand(_POS, cc, nn)

Arguments: 2

Argument 1: Channel Type: Unsigned 8-bit

Min: 1 Max: Total number of motors

Argument 2: Value Type: Signed 32-bit

Where:

cc = Motor channel

nn = Target position

PSP – Profile Velocity (DS402)

Alias: PSP HexCode: 5D CANOpen id: 0x6081

Description:

This command is used to set the velocity in RPM, normally attained at the end of the acceleration ramp during a profiled motion and is valid for both directions of motion.

Syntax Serial: !PSP cc nn

Syntax Scripting: SetCommand(_PSP, cc, nn)

Arguments: 2

Argument 1: Channel Type: Unsigned 8-bit

 Min: 1 Max: Total number of motors

Argument 2: Value Type: Unsigned 16-bit

Where:

cc = Motor channel

nn = Profile velocity

ROM – Modes of Operation (DS402)

Alias: ROM HexCode: 5A CANOpen id: 0x6060

Description:

This command configures the modes of operation.

Syntax Serial: !ROM cc nn

Syntax Scripting: SetCommand(_ROM, cc, nn)

Arguments: 2

Argument 1: Channel Type: Unsigned 8-bit

 Min: 1 Max: Total number of motors

Argument 2: Value Type: Signed 8-bit

Where

cc = Motor channel

nn = Modes of operation

S – Target Velocity (DS402)

Alias: MOTVEL HexCode: 03 CANOpen id: 0x6042, 0x60FF

Description:

Sets the required velocity of the system in RPM. Positive values shall indicate forward direction and negative values shall indicate reverse direction.

Syntax Serial: !S cc nn

Syntax Scripting: SetCommand(_S, cc, nn)

SetCommand(_MOTVEL, cc, nn)

Arguments: 2

Argument 1: Channel Type: Unsigned 8-bit

Min: 1 Max: Total number of motors

Argument 2: Value Type: Signed 16-bit

Min: -500000 Max: 500000

Where:

cc = Motor channel

nn = Target velocity in RPM

SAC – Velocity Acceleration (DS402)

Alias: SAC HexCode: 58 CANOpen id: 0x6048

Description:

This command configures the velocity acceleration.

Syntax Serial: !SAC ee nn

Syntax Scripting: SetCommand(_SAC, ee, nn)

Arguments: 2

Argument 1: Element Type: Unsigned 8-bit

Min: 1 Max: 2 × Total number of motors

Argument 2: Value Type: Unsigned 32-bit

Where:

ee =

1: Delta speed in 10×RPM for channel 1

2: Delta time in seconds for channel 1

3: Delta speed in 10×RPM for channel 2

4: Delta time in seconds for channel 2

...

2 × (m - 1) + 1: Delta speed in 10×RPM for channel m.

2 × (m - 1) + 1: Delta time in seconds for channel m.

nn = Delta speed/time

SDC – Velocity Deceleration (DS402)

Alias: SDC HexCode: 59 CANOpen id: 0x6049

Description:
This command configures the velocity deceleration.

Syntax Serial: !SDC ee nn

Syntax Scripting: SetCommand(_SDC, ee, nn)

Arguments: 2

Argument 1: Element Type: Unsigned 8-bit
Min: 1 Max: 2 × Total number of motors

Argument 2: Value Type: Unsigned 32-bit

Where:

ee =

- 1: Delta speed in 10×RPM for channel 1
 - 2: Delta time in seconds for channel 1
 - 3: Delta speed in 10×RPM for channel 2
 - 4: Delta time in seconds for channel 2
 - ...
 - $2 \times (m - 1) + 1$: Delta speed in 10×RPM for channel m.
 - $2 \times (m - 1) + 1$: Delta time in seconds for channel m.
- nn = Delta speed/time

SPL – Velocity Min/Max Amount (DS402)

Alias: SPL HexCode: 57 CANOpen id: 0x6046

Description:

This command configures the minimum and maximum amount of velocity in RPM. The vl velocity max amount is mapped internally to the vl velocity max positive and vl velocity min max negative values. The vl velocity min amount is be mapped internally to the vl velocity min positive and vl velocity min negative values as shown in Figure 15-1.

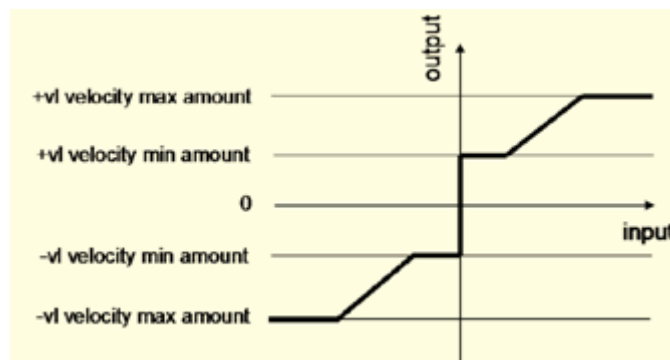

FIGURE 15-1. Velocity Min Max Amount

Syntax Serial: !SPL ee nn

Syntax Scripting: SetCommand(_SPL, ee, nn)

Arguments: 2

Argument 1: Element Type: Unsigned 8-bit
 Min: 1 Max: 2 × Total number of motors

Argument 2: Value Type: Unsigned 32-bit

Where:

ee =

- 1: Min amount for channel 1
 - 2: Max amount for channel 1
 - 3: Min amount for channel 2
 - 4: Max amount for channel 2
 - ...
 - 2 × (m - 1) + 1: Min amount for channel m.
 - 2 × (m - 1) + 1: Max amount for channel m.
- nn = Velocity max/min amount

TC – Target Torque (DS402)

Alias: TC HexCode: 5B CANOpen id: 0x6071

Description:

This command configures the input value in 100×Nm for the torque where the controller in torque mode.

Syntax Serial: !TC cc nn

Syntax Scripting: SetCommand(_TC, cc, nn)

Arguments: 2

Argument 1: Channel Type: Unsigned 8-bit
 Min: 1 Max: Total number of motors

Argument 2: Value Type: Signed 16-bit

Where:

- cc = Motor channel
- nn = Torque input value in 100×Nm

TSL – Torque Slope (DS402)

Alias: TSL

HexCode: 60

CANOpen id: 0x6087

Description:

This command is used to set the rate of change of torque, in 10×miliNm/second as long as the Torque Constant (TNM) is 1000 miliNm/A.

Syntax Serial: !TSL cc nn

Syntax Scripting: SetCommand(_TSL, cc, nn)

Arguments: 2

Argument 1: Channel

Type: Unsigned 8-bit

Min: 1

Max: total number of motors

Argument 2: Value

Type: Unsigned 32-bit

Where:

cc = Motor channel

nn = Torque slope

Runtime Queries

Runtime queries can be used to read the value of real-time measurements at any time during the controller operation. Real-time queries are very short commands that start with “?” followed by one to three letters. In some instances, queries can be sent with or without a numerical parameter.

Without parameter, the controller will reply with the values of all channels. When a numerical parameter is sent, the controller will respond with the value of the channel selected by that parameter.

Example:

```
Q: ?T
R: T=20:30:40
```

```
Q: ?T2
R: T=30
```

All queries are stored in a history buffer that can be made to automatically recall the past 16 queries at a user-selectable time interval. See “Query History Commands” on page 197.

Routine queries can be sent from within a MicroBasic Script using the `getvalue()` function.

TABLE 15-10. Runtime Queries

Command	Argument	Description
A	Channel	Read Motor Amps
AI	InputNbr	Read Analog Inputs
AIC	InputNbr	Read Analog Input after Conversion
ANG	Channel	Read Rotor Angle
ASI	Channel	Read Raw Sin/Cos sensor
B	VarNbr	Read User Boolean Variable
BA	Channel	Read Battery Amps
BCR	Channel	Read Brushless Count Relative
BS	Channel	Read BL Motor Speed in RPM
BSC	SensorNumber	Read Battery State of Charge in percentage
BSR	Channel	Read BL Motor Speed as 1/1000 of Max RPM
BMC	SensorNumber	Read Battery State Of Charge in AmpHours
BMF	SensorNumber	Read BMS Status Flags
BMS	SensorNumber	Read BMS Switch States
C	Channel	Read Encoder Counter Absolute
CAN	Element	Read Raw CAN frame
CB	Channel	Read Absolute Brushless Counter
CF	None	Read Raw CAN Received Frames Count
CIA	Channel	Read Converted Analog Command
CIP	Channel	Read Internal Pulse Command
CIS	Channel	Read Internal Serial Command
CL	Group	Read RoboCAN Alive Nodes Map
CR	Channel	Read Encoder Count Relative
CSR	Channel	Read Relative SSI Sensor Counter
CSS	Channel	Read Absolute SSI Sensor Counter
D	None	Read Digital Inputs
DI	InputNbr	Read Individual Digital Inputs
DO	None	Read Digital Output Status
DPA	Channel	Read Motor DC/Peak Amps
DR	Channel	Read Destination Reached
E	Channel	Read Closed Loop Error
F	Channel	Read Feedback
FC	Channel	Read FOC Angle Adjust
FLW	SensorNumber	Read Flow Sensor Counter
FF	None	Read Fault Flags
FID	None	Read Firmware ID
FIN	None	Read Firmware ID (numerical)
FM	Channel	Read Runtime Status Flag
FS	None	Read Status Flags
HS	Channel	Read Hall Sensor States

TABLE 15-10. Runtime Queries

Command	Argument	Description
ICL	NodeId	Is RoboCAN Node Alive
K	Channel	Read Spektrum Receiver
LK	None	Read Lock status
M	Channel	Read Motor Command Applied
MA	AmpsChannel	Read Field Oriented Control Motor Amps
MGD	SensorNumber	Read Magsensor Track Detect
MGM	SensorNumber	Read Magsensor Markers
MGS	SensorNumber	Read Magsensor Status
MGT	Channel	Read Magsensor Track Position
MGY	Channel	Read Magsensor Gyroscope
MGX	SensorNumber	Read MagSensor Tape Cross Detection
P	Channel	Read Motor Power Output Applied
PHA	CurrentSensorNumber	Read Phase Amps
PI	InputNbr	Read Pulse Inputs
PIC	InputNbr	Read Pulse Input after Conversion
S	Channel	Read Encoder Motor Speed in RPM
SCC	None	Read Script Checksum
SNA	Channel	Read Sensor Angle
SR	Channel	Read Encoder Speed Relative
SS	Channel	Read SSI Sensor Motor Speed in RPM
SSR	Channel	Read SSI Sensor Speed Relative
STT	None	STO Self-Test Result
T	SensorNbr	Read Temperature
TM	Element	Read Time
TR	Channel	Read Position Relative Tracking
TRN	None	Read Control Unit type and Controller Model
UID	Element	Read MCU Id
V	SensorNumber	Read Volts
VAR	VarNumber	Read User Integer Variable

A - Read Motor Amps

Alias: MOTAMPS

HexCode: 00

CANOpen id: 0x2100

Description:

Measures and reports the motor Amps, in Amps*10, for all operating channels. For brushless controllers this query reports the RMS value. Note that the current flowing through the motors is often higher than this flowing through the battery.

Syntax Serial: ?A [cc]

 Argument: Channel
 Min: 1 Max: Total Number of Motors

Syntax Scripting: `result = getvalue(_A, cc)`
`result = getvalue(_MOTAMPS, cc)`

Reply:

A = aa Type: Signed 16-bit Min: 0

Where:

cc = Motor channel
 aa = Amps * 10 for each channel

Example:

Q: ?A
 R: A=100:200
 Q: ?A 2
 R: A=200

Note:

Single channel controllers will report a single value. Some power board units measure the Motor Amps and calculate the Battery Amps, while other models measure the Battery Amps and calculate the Motor Amps. The measured Amps is always more precise than the calculated Amps. See controller datasheet to find which Amps is measured by your particular model.

AI - Read Analog Inputs

Alias: ANAIN HexCode: 10 CANOpen id: 0x2146

Description:

Reports the raw value in mV of each of the analog inputs that are enabled. Input that is disabled will report 0. The total number of Analog input channels varies from one controller model to another and can be found in the product datasheet.

Syntax Serial: ?AI [cc]

Argument: InputNbr
 Min: 1 Max: Max Number of Analog Inputs

Syntax Scripting: `result = getvalue(_AI, cc)`
`result = getvalue(_ANAIN, cc)`

Reply:

AI=nn Type: Signed 16-bit Min: 0 Max: 5300

Where:

cc = Analog Input number
 nn = Millivolt for each channel

AIC - Read Analog Input after Conversion

Alias: ANAINC HexCode: 23 CANOpen id: 0x2147

Description:

Returns value of an Analog input after all the adjustments are performed to convert it to a command or feedback value (Min/Max/Center/Deadband/Linearity). If an input is disabled,

the query returns 0. The total number of Analog input channels varies from one controller model to another and can be found in the product datasheet.

Syntax Serial: ?AIC [cc]

Argument: InputNbr
Min: 1 Max: Total Number of Analog Inputs

Syntax Scripting: result = getvalue(_AIC, cc)
result = getvalue(_ANAINC, cc)

Reply:

AIC=nn Type: Signed 16-bit Min: -1000 Max: 1000

Where:

cc = Analog Input number
nn = Converted analog input value +/-1000 range

ANG - Read Rotor Angle

Alias: ANG HexCode: 42 CANOpen id: 0x2132

Description:

On brushless controller operating in sinusoidal mode, this query returns the real time value of the rotor's electrical angle of brushless motor. This query is useful for verifying troubleshooting sin/cos and SPI/SSI sensors. Angle are reported in 0-511 degrees.

Syntax Serial: ?ANG [cc]

Argument: Channel
Min: 1 Max: Total Number of Motors

Syntax Scripting: result = getvalue(_ANG, cc)

Reply:

ANG=nn Type: Unsigned 16-bit Min: 0 Max: 511

Where:

cc = Motor channel
nn = Rotor electrical angle

ASI - Read Raw Sin/Cos sensor

Alias: ASI HexCode: 33 CANOpen id:

Description:

Returns real time raw values of ADC connected to sin/cos sensors of each motor or the real time values of the raw data reported by the SSI sensor of the motor. This query is useful for verifying troubleshooting sin/cos sensors and SSI sensors.

Syntax Serial: ?ASI [cc]

Argument: Channel
 Min: 1 Max: 2 * Number of Motors

Syntax Scripting: result = getvalue(_ASI, cc)

Reply:

ASI=nn Type: Unsigned 16-bit Min: 0 Max: 65535

Where:

cc =
 1 : Sin input 1/SSI input 1
 2 : Cos input 1
 3 : Sin input 2/SSI input 2
 4 : Cos input 2
 nn = ADC value

B - Read User Boolean Variable

Alias: BOOL HexCode: 16 CANOpen id: 0x2115

Description:

Read the value of boolean internal variables that can be read and written to/from within a user MicroBasic script. It is used to pass boolean states between user scripts and a microcomputer connected to the controller. The total number of user boolean variables varies from one controller model to another and can be found in the product datasheet.

Syntax Serial: ?B [nn]

Argument: VarNbr
 Min: 1 Max: Total Number of Bool Variables

Syntax Scripting: result = getvalue(_B, nn)
 result = getvalue(_BOOL, nn)

Reply:

B=bb Type: Boolean Min: 0 Max: 1

Where:

nn = Boolean variable number
 bb = 0 or 1 state of the variable

BA - Read Battery Amps

Alias: BATAMPS HexCode: 0C CANOpen id: 0x210C

Description:

Measures and reports the Amps flowing from the battery in Amps * 10. Battery Amps are often lower than motor Amps.

Syntax Serial: ?BA [cc]

Argument: Channel:
 Min: 1 Max: Total Number of Motors

Syntax Scripting: `result = getvalue(_BA, cc)`
`result = getvalue(_BATAMPS, cc)`

Reply:

BA=aa Type: Signed 16-bit Min: 0

Where:

cc = Motor channel
aa = Amps *10 for each channel

Example:

Q: ?BA R:
BA=100:200

Note:

Some controller models measure the Motor Amps and Calculate the Battery Amps, while other models measure the Battery Amps and calculate the Motor Amps. The measured Amps is always more precise than the calculated Amps. See controller datasheet to find which Amps is measured by your particular model.

BCR - Read Brushless Count Relative

Alias: BLRCNTR HexCode: 09 CANOpen id: 0x2109

Description:

Returns the amount of Internal sensor (Hall, SinCos, Resolver) counts that have been measured from the last time this query was made. Relative counter read is sometimes easier to work with, compared to full counter reading, as smaller numbers are usually returned.

Syntax Serial: ?BCR [cc]

Argument: Channel
Min: 1 Max: Total Number of Motors

Syntax Scripting: `result = getvalue(_BCR, cc)`
`result = getvalue(_BLRCNTR, cc)`

Reply:

BCR=nn Type: Signed 32-bit Min: -2147M Max: 2147M

Where:

cc = Motor channel
nn = Value

BMC - Read BMS State Of Charge in AmpHours

Alias: - HexCode: 4C CANOpen id: 0x2141

Description:

When one or more BMS10X0 are connected to the controller, this query reports the Battery's State Of Charge in AmpHours, which is connected to the respective BMS10X0. If

only one BMS10X0 is connected to any pulse input this query will report the data of that device, regardless which pulse input it is connected to. If more than one BMS10X0 is connected to pulse inputs and these inputs are enabled and configured in BMS MultiPWM mode, then the argument following the query is used to select the sensor.

Syntax Serial: ?BMC [cc]

Argument: SensorNumber
 Min: None Max: Total Number of Pulse Inputs

Syntax Scripting: result = getvalue(_BMC, cc)

Reply:

BMC=nn Type: Unsigned 8-bit Min: 0 Max: 255

Where:

cc = (When only one sensor enabled)

None or 1 : Current BMS10X0

cc = (When several sensors enabled)

1 : BMS10X0 at pulse input 1

2 : BMS10X0 at pulse input 2

...

p : BMS10X0 at pulse input p

nn = AmpHours (Ah)

BMF - Read BMS status flags

Alias: - HexCode: 4D CANOpen id: 0x2142

Description:

When one or more BMS10X0 are connected to the controller, this query reports the status flags of the respective BMS10X0. If only one BMS10X0 is connected to any pulse input this query will report the data of that device, regardless which pulse input it is connected to. If more than one BMS10X0 is connected to pulse inputs and these inputs are enabled and configured in BMS MultiPWM mode, then the argument following the query is used to select the sensor.

Syntax Serial: ?BMF [cc]

Argument: SensorNumber
 Min: None Max: Total Number of Pulse Inputs

Syntax Scripting: result = getvalue(_BMF, cc)

Reply:

BMF = f1 + f2*2 + f3*4 + ... + fn*2^n-1 Type: Unsigned 8-bit Min: 0 Max: 255

Where:

cc = (When only one sensor enabled)

None or 1 : Current BMS10X0

cc = (When several sensors enabled)

1 : BMS10X0 at pulse input 1

2 : BMS10X0 at pulse input 2

...

p : BMS10X0 at pulse input p

and

f1 = Unsafe Temperature

f2 = Over or Under Voltage Error Set

f3 = Amp Trigger Set

f4 = Over Current Error Set

f5 = Short Load or Inv Charger

f6 = Bad State Of Health

f7 = Config Error

f8 = Internal Fault

BMS - Read BMS switch states

Alias: -

HexCode: 4E

CANOpen id: 0x2143

Description:

When one or more BMS10X0 are connected to the controller, this query reports the switch states of the respective BMS10X0. If only one BMS10X0 is connected to any pulse input this query will report the data of that device, regardless which pulse input it is connected to. If more than one BMS10X0 is connected to pulse inputs and these inputs are enabled and configured in BMS MultiPWM mode, then the argument following the query is used to select the sensor.

Syntax Serial: ?BMC [cc]

Argument: SensorNumber

Min: None

Max: Total Number of Pulse Inputs

Syntax Scripting: result = getvalue(_BMC, cc)

Reply:

BMC = f1 + f2*2 + f3*4 + ... + fn*2ⁿ⁻¹ Type: Unsigned 8-bit Min: 0 Max: 255

Where:

cc = (When only one sensor enabled)

None or 1 : Current BMS10X0
 cc = (When several sensors enabled)
 1 : BMS10X0 at pulse input 1
 2 : BMS10X0 at pulse input 2
 ...
 p : BMS10X0 at pulse input p
 and
 f1 = Pack Switch
 f2 = Load Switch
 f3 = Charger Switch
 f4 = Brake Resistor / Aux Switch
 f5 = Reserved
 f6 = Bluetooth Vcc switch
 f7 = Reserved
 f8 = Reserved

BS - Read BL Motor Speed in RPM

Alias: BLSPEED HexCode: 0A CANOpen id: 0x210A

Description:

On brushless motor controllers, reports the actual speed measured using the motor’s Internal sensors (Hall, SinCos, Resolver) as the actual RPM value. To report RPM accurately, the correct number of motor poles must be loaded in the BLPOL configuration parameter.

Syntax Serial: ?BS [cc]

Argument: Channel
 Min: 1 Max: Total Number of Motors

Syntax Scripting: result = getvalue(_BS, cc)
 result = getvalue(_BLSPEED, cc)

Reply:

BS=nn Type: Signed 32-bit Min: -65535 Max: 65535

Where:

cc = Motor channel
 nn = Speed in RPM

BSC - Read BMS State of Charge in percentage

Alias: - HexCode: 50 CANOpen id: 0x213A

Description:

When one or more BMS10X0 are connected to the controller, this query reports the Battery’s State Of Charge in percentage, which is connected to the respective BMS10X0. If

only one BMS10X0 is connected to any pulse input this query will report the data of that device, regardless which pulse input it is connected to. If more than one BMS10X0 is connected to pulse inputs and these inputs are enabled and configured in BMS MultiPWM mode, then the argument following the query is used to select the sensor.

Syntax Serial: ?BSC [cc]

Argument: SensorNumber
 Min: None Max: Total Number of Pulse Inputs

Syntax Scripting: result = getvalue(_BSC, cc)

Reply:

BSC=nn Type: Unsigned 8-bit Min: 0 Max: 255

Where:

cc = (When only one sensor enabled)

None or 1 : Current BMS10X0

cc = (When several sensors enabled)

1 : BMS10X0 at pulse input 1

2 : BMS10X0 at pulse input 2

...

p : BMS10X0 at pulse input p

nn = State Of Charge (%)

BSR - Read BL Motor Speed as 1/1000 of Max RPM

Alias: BLRSPEED HexCode: 0B CANOpen id: 0x210B

Description:

On brushless motor controllers, returns the measured motor speed, using the motor's Internal sensors (Hall, Sin/Cos, Resolver), as a ratio of the Max RPM configuration parameter. The result is a value of between 0 and +/-1000. Note that if the motor spins faster than the Max RPM, the return value will exceed 1000. However, a larger value is ignored by the controller for its internal operation. To report an accurate result, the correct number of motor poles must be loaded in the BLPOL configuration parameter.

Syntax Serial: ?BSR

Argument: Channel
 Min: 1 Max: Total Number of Motors

Syntax Scripting: result = getvalue(_BSR,)
 result = getvalue(_BLRSPEED,)

Reply:

BSR=nn Type: Signed 16-bit Min: -1000 Max: 1000

Where:

nn = Speed relative to max

Example:

Q: ?BSR

R: BSR=500: speed is 50% of the RPM value stored in the Max RPM configuration

C - Read Encoder Counter Absolute

Alias: ABCNTR HexCode: 04 CANOpen id: 0x2104

Description:

Returns the encoder value as an absolute number. The counter is 32-bit with a range of +/- 2147483648 counts.

Syntax Serial: ?C [cc]

Argument: Channel
 Min: 1 Max: Total Number of Encoders

Syntax Scripting: result = getvalue(_C, cc)
 result = getvalue(_ABCNTR, cc)

Reply:

C=nn Type: Signed 32-bit Min: -2147M Max: 2147M

Where:

cc = Encoder channel number
 nn = Absolute counter value

CAN - Read Raw CAN frame

Alias: CAN HexCode: 27 CANOpen id:

Description:

This query is used in CAN-enabled controllers to read the content of a received CAN frame in the RawCAN mode. Data will be available for reading with this query only after a ?CF query is first used to check how many received frames are pending in the FIFO buffer. When the query is sent without arguments, the controller replies by outputting all elements of the frame separated by colons.

Syntax Serial: ?CAN [ee]

Argument: Element
 Min: 1 Max: 10

Syntax Scripting: result = getvalue(_CAN, ee)

Reply:

CAN = dd1:dd2:dd3: ... :dd10 Type: Unsigned 16-bit Min: 0 Max: 255

Where:

ee = Byte in frame

dd1 = Header

dd2 = Bytecount

dd3 to dd10 = Data0 to data7

Example:

Q: ?CAN

R: CAN=5:4:11:12:13:14:0:0:0:0

Q: ?CAN 3

R: CAN=11

CB - Read Absolute Brushless Counter

Alias: BLCNTR

HexCode: 05

CANOpen id: 0x2105

Description:

On brushless motor controllers, returns the running total of Internal sensor (Hall, SinCos, Resolver) transition value as an absolute number. The counter is 32-bit with a range of +/- 2147483648 counts.

Syntax Serial: ?CB [cc]

Argument: Channel

Min: 1 Max: Total Number of Motors

Syntax Scripting: result = getvalue(_CB, cc)

result = getvalue(_BLCNTR, cc)

Reply:

CB=nn Type: Signed 32-bit Min: -2147M Max: 2147M

Where:

cc = Motor channel

nn = Absolute counter value

CF - Read Raw CAN Received Frames Count

Alias: CF

HexCode: 28

CANOpen id:

Description:

This query is used to read the number of received CAN frames pending in the FIFO buffer and copies the oldest frame into the read buffer, from which it can then be accessed using the ?CAN query. Sending ?CF again, copies the next frame into the read buffer. The controller can buffer up to 16 CAN frames

Syntax Serial: ?CF

Argument: None

Syntax Scripting: result = getvalue(_CF, 1)

Reply:

CF=nn Type: Unsigned 8-bit Min: 0 Max: 16

Where:

nn = Number of frames in receive queue

CIA - Read Converted Analog Command

Alias: CMDANA

HexCode: 1A

CANOpen id: 0x2117

Description:

Returns the motor command value that is computed from the Analog inputs whether or not the command is actually applied to the motor. The Analog inputs must be configured as Motor Command. This query can be used, for example, to read the command joystick from within a MicroBasic script or from an external microcomputer, even though the controller may be currently responding to Serial or Pulse command because of a higher priority setting. The returned value is the raw Analog input value with all the adjustments performed to convert it to a command (Min/Max/Center/Deadband/Linearity).

Syntax Serial: ?CIA [cc]

Argument: Channel

Min: 1 Max: Total Number of Motors

Syntax Scripting: result = getvalue(_CIA, cc)
result = getvalue(_CMDANA, cc)

Reply:

CIA=nn Type: Signed 32-bit Min: -1000 Max: 1000

Where:

cc = Motor channel

nn = Command value in +/-1000 range

CIP - Read Internal Pulse Command

Alias: CMDPLS

HexCode: 1B

CANOpen id: 0x2118

Description:

Returns the motor command value that is computed from the Pulse inputs whether or not the command is actually applied to the motor. The Pulse input must be configured as Motor Command. This query can be used, for example, to read the command joystick from within a MicroBasic script or from an external microcomputer, even though the controller may be currently responding to Serial or Analog command because of a higher priority setting. The returned value is the raw Pulse input value with all the adjustments performed to convert it to a command (Min/Max/Center/Deadband/Linearity).

Syntax Serial: ?CIP [cc]

Argument: Channel
Min: 1 Max: Total Number of Motors

Syntax Scripting: result = getvalue(_CIP, cc)
result = getvalue(_CMDPLS, cc)

Reply:

CIP=nn Type: Signed 32-bit Min: -1000 Max: 1000

Where:

cc = Motor channel
nn = Command value in +/-1000 range

CIS - Read Internal Serial Command

Alias: CMDSER HexCode: 19 CANOpen id: 0x2116

Description:

Returns the motor command value that is issued from the serial input or from a MicroBasic script whether or not the command is actually applied to the motor. This query can be used, for example, to read from an external microcomputer the command generated inside MicroBasic script, even though the controller may be currently responding to a Pulse or Analog command because of a higher priority setting.

Syntax Serial: ?CIS [cc]

Argument: Channel
Min: 1 Max: Total Number of Motors

Syntax Scripting: result = getvalue(_CIS, cc)
result = getvalue(_CMDSER, cc)

Reply:

CIS=nn Type: Signed 32-bit Min: -1000 Max: 1000

Where:

cc = channel
nn = command value in +/-1000 range

CL - Read RoboCAN Alive Nodes Map

Alias: CALIVE HexCode: 26 CANOpen id:

Description:

With CL it is possible to see which nodes in a RoboCAN are alive and what type of device is present at each node. A complete state of the network is represented in sixteen 32-bit numbers. Within each 32-bit word are 8 groups of 4-bits. The 4-bits contain the node information. E.g. bits 0-3 of first number is for node 0, bits 8-11 of first number is for node 2, bits 4-7 of second number is for node 5 and bits 12-15 of fourth number is for node 11, etc.

Syntax Serial: ?CL nn

Argument: Group
Min: 1 Max: 16

Syntax Scripting: result = getvalue(_CL, nn)
result = getvalue(_CALIVE, nn)

Reply:
CL=mm Type: Unsigned 32-bit Min: 0 Max: 4194M

Where:
nn =
1 : nodes 0-3
2 : nodes 4-7
...
...
15 : nodes 120-123
16 : nodes 124-127
mm = 4 words of 4 bits. Each 4-bit word:
0b0000 : Inactive node
0b0001 : Active motor controller
0b0011 : Active magsensor
0b0101 : Active RIOX
0b0111 : Active BMS
0b1001 : Active OTS
0b1011 : Active FLW

CR - Read Encoder Count Relative

Alias: RELCNTR HexCode: 08 CANOpen id: 0x2108

Description:

Returns the amount of counts that have been measured from the last time this query was made. Relative counter read is sometimes easier to work with, compared to full counter reading, as smaller numbers are usually returned.

Syntax Serial: ?CR [cc]

Argument: Channel
Min: 1 Max: Total Number of Encoders

Syntax Scripting: result = getvalue(_CR, cc)
result = getvalue(_RELCNTR, cc)

Reply:
CR=nn Type: Signed 32-bit Min: -2147M Max: 2147

Where:
cc = Motor channel
nn = Counts since last read using ?CR

CSR - Read Relative SSI Sensor Counter

Alias: - HexCode: 6D CANOpen id: 0x213F

Description:

Returns the amount of counts that have been measured from the last time this query was made. Relative counter read is sometimes easier to work with, compared to full counter reading, as smaller numbers are usually returned.

Syntax Serial: ?CSR [cc]

Argument: Channel
 Min: 1 Max: Total Number of SSI Encoders

Syntax Scripting: result = getvalue(_CSR, cc)

Reply:

CSR=nn Type: Signed 32-bit Min: -2147M Max: 2147

Where:

cc = SSI sensor channel
nn = Counts since last read using ?CSR

CSS - Read Absolute SSI Sensor Counter

Alias: - HexCode: 6E CANOpen id: 0x213E

Description:

Returns the SSI encoder value as an absolute number. The counter is 32-bit with a range of +/- 2147483648 counts.

Syntax Serial: ?CSS [cc]

Argument: Channel
 Min: 1 Max: Total Number of SSI Encoders

Syntax Scripting: result = getvalue(_CSS, cc)

Reply:

CSS=nn Type: Signed 32-bit Min: -2147M Max: 2147

Where:

cc = SSI sensor channel
nn = Absolute counter value

D - Read Digital Inputs

Alias: DIGIN HexCode: 0E CANOpen id: 0x210E

Description:

Reports the status of each of the available digital inputs. The query response is a single digital number which must be converted to binary and gives the status of each of the inputs. The total number of Digital input channels varies from one controller model to another and can be found in the product datasheet.

Syntax Serial: ?D

Argument: None

Syntax Scripting: result = getvalue(_D, 1)
 result = getvalue(_DIGIN, 1)

Reply:

D=nn Type: Unsigned 32-bit

Where:

$nn = b_1 + b_2 * 2 + b_3 * 4 + \dots + b_n * 2^{n-1}$

Example:

Q: ?D

R: D=17 : Inputs 1 and 5 active, all others inactive

DI - Read Individual Digital Inputs

Alias: DIN HexCode: 0F CANOpen id: 0x2145

Description:

Reports the status of an individual Digital Input. The query response is a boolean value (0 or 1). The total number of Digital input channels varies from one controller model to another and can be found in the product datasheet.

Syntax Serial: ?DI [cc]

Argument: InputNbr
 Min: 1 Max: Total Number of Digital Inputs

Syntax Scripting: result = getvalue(_DI, cc)
 result = getvalue(_DIN, cc)

Reply:

DI=nn Type: Boolean Min: 0 Max: 1

Where:

cc = Digital Input number
nn = 0 or 1 state for each input

Example:

Q: ?DI

R: DI=1:0:1:0:1:0

Q: ?DI 1

R: DI=0

DO - Read Digital Output Status

Alias: DIGOUT HexCode: 17 CANOpen id: 0x2113

Description:

Reads the actual state of all digital outputs. The response to that query is a single number which must be converted into binary in order to read the status of the individual output bits. When querying an individual output, the reply is 0 or 1 depending on its status. The total number of Digital output channels varies from one controller model to another and can be found in the product datasheet.

Syntax Serial: ?DO

Argument: None

Syntax Scripting: result = getvalue(_DO, 1)
 result = getvalue(_DIGOUT, 1)

Reply:

DO=nn Type: Unsigned 16-bit Min: 0 Max: 65536

Where:

$nn = d1 + d2*2 + d3*4 + \dots + dn * 2^{n-1}$

Example:

Q: ?DO

R: DO=17 : Outputs 1 and 5 active, all others inactive

DPA - Read DC/Peak Amps

Alias: - HexCode: 6E CANOpen id: -

Description:

Applicable only for brushless controllers. Measures and reports the Peak Amps , in Amps*10, for all operating channels.

Syntax Serial: ?DPA [cc]

Argument: Channel

 Min: 1 Max: Total Number of Motors

Syntax Scripting: result = getvalue(_DPA, cc)

Reply:

DPA = aa Type: Signed 16-bit Min: 0

Where:

cc = Motor channel

aa = Amps * 10 for each channel

Example:

Q: ?DPA

R: DPA=100:200

Q: ?DPA 2

R: DPA=200

DR - Read Destination Reached

Alias: DREACHED HexCode: 22 CANOpen id: 0x211B

Description:

This query is used when chaining commands in Position Count mode, to detect that a destination has been reached and that the next destination values that were loaded in the buffer have become active. The Destination Reached bit is latched and is cleared once it has been read.

Syntax Serial: ?DR [cc]

Argument: Channel
Min: 1 Max: Total Number of Motors

Syntax Scripting: result = getvalue(_DR, cc)
 result = getvalue(_DREACHED, cc)

Reply:

DR=nn Type: Unsigned 8-bit Min: 0 Max: 1

Where:

cc = Motor channel

nn =

0 : Not yet reached

1 : Reached

E - Read Closed Loop Error

Alias: LPERR HexCode: 18 CANOpen id: 0x2114

Description:

In closed-loop modes, returns the difference between the desired speed or position and the measured feedback. This query can be used to detect when the motor has reached the desired speed or position. In open loop mode, this query returns 0.

Syntax Serial: ?E [cc]

Argument: Channel
Min: 1 Max: Total Number of Motors

Syntax Scripting: result = getvalue(_E, cc)
result = getvalue(_LPERR, cc)

Reply:

E=nn Type: Signed 32-bit Min: -2147M Max: 2147M

Where:

cc = Motor channel
nn = Error value

F - Read Feedback

Alias: FEEDBK HexCode: 13 CANOpen id: 0x2110

Description:

Reports the value of the feedback sensors that are associated to each of the channels in closed-loop modes. The feedback source can be Encoder, Analog or Pulse. Selecting the feedback source is done using the encoder, pulse or analog configuration parameters. This query is useful for verifying that the correct feedback source is used by the channel in the closed-loop mode and that its value is in range with expectations.

Syntax Serial: ?F [cc]

Argument: Channel
Min: 1 Max: Total Number of Motors

Syntax Scripting: result = getvalue(_F, cc)
result = getvalue(_FEEDBK, cc)

Reply:

F=nn Type: Signed 32-bit Min: -2147M Max: 2147M

Where:

cc = Motor channel
nn = Feedback values

FC - Read FOC Angle Adjust

Alias: FC HexCode: 47 CANOpen id: 0x2135

Description:

Read in real time the angle correction that is currently applied by the Field Oriented algorithm in order to achieve optimal performance.

Syntax Serial: ?FC [cc]

Argument: Channel
Min: 1 Max: Total Number of Motors

Syntax Scripting: result = getvalue(_FC, cc)

Reply:

FC = nn Type: Signed 16-bit Min: -512 Max: 512

Where:

cc = Motor channel
nn = Angle correction

FLW - Read Flow Sensor Counter

Alias: - HexCode: 7B CANOpen id: 0x214A

Description:

When one or more FLW100 are connected to the controller, this query reports the count measurements of X and Y axis in mm*10 of the respective FLW100. If only one FLW100 is connected to any pulse input this query will report the data of that device, regardless which pulse input it is connected to. If more than one FLW100 is connected to pulse inputs and these inputs are enabled and configured in FlowSensor MultiPWM mode, then the argument following the query is used to select the sensor.

Syntax Serial: ?FLW [cc]

Argument: SensorNumber
 Min: 1 Max: 2*Total Number of Pulse Inputs

Syntax Scripting: result = getvalue(_FLW, cc)

Reply:

FLW=nn Type: Signed 32-bit Min: -2147M Max: 2147M

Where:

cc = (When only one sensor enabled)

1 : X Counter

2: Y Counter

cc = (When several sensors enabled)

1 : X Counter of sensor at pulse input 1

2 : Y Counter of sensor at pulse input 1

3 : X Counter of sensor at pulse input 2

4 : Y Counter of sensor at pulse input 2

...

((p-1)*2)+1 : X Counter of sensor at pulse input p

((p-1)*2)+2 : Y Counter of sensor at pulse input p

nn = Distance in mm*10.

FF - Read Fault Flags

Alias: FLTFLAG HexCode: 15 CANOpen id: 0x2112

Description:

Reports the status of the controller fault conditions that can occur during operation. The response to that query is a single number which must be converted into binary in order to evaluate each of the individual status bits that compose it.

Syntax Serial: ?FF

Argument: None

Syntax Scripting: result = getvalue(_FF, 1)
 result = getvalue(_FLTFLAG, 1)

Reply:

FS = f1 + f2*2 + f3*4 + ... + fn*2^n-1 Type: Unsigned 16-bit Min: 0 Max: 65535

Where:

f1 = Overheat

f2 = Overvoltage

f3 = Undervoltage

f4 = Short circuit

f5 = Emergency stop

f6 = Motor/Sensor Setup fault

f7 = MOSFET failure

f8 = Default configuration loaded at startup

Example:

Q: ?FF

R: FF=2 : Overvoltage fault

FID - Read Firmware ID

Alias: FID HexCode: 1E CANOpen id:

Description:

This query will report a string with the date and identification of the firmware revision of the controller.

Syntax Serial: ?FID

Argument: None

Syntax Scripting: result = getvalue(_FID, 1)

Reply:

FID=ss Type: String

Where:

ss = Firmware ID string

Example:

Q: ?FID

R: FID=Roboteq v1.6 RCB500 05/01/2016

FIN - Read Firmware ID (numerical)

Alias: - HexCode: 3F CANOpen id: 0x2137

Description:

This query will report the version and the date of the firmware revision of the controller.

Syntax Serial: ?FIN [ee]

Argument: Element
Min: None Max: 4

Syntax Scripting: result = getvalue(_FIN, ee)

Reply:

FID = nn Type: Unsigned 16-bit Min: 0

Where:

ee = Firmware Version Element

1: Version

2: Month

3: Day

4: Year

nn = Value.

FM - Read Runtime Status Flag

Alias: MOTFLAG HexCode: 30 CANOpen id: 0x2122

Description:

Report the runtime status of each motor. The response to that query is a single number which must be converted into binary in order to evaluate each of the individual status bits that compose it.

Syntax Serial: ?FM [cc]

Argument: Channel
Min: 1 Max: Total Number of Motors

Syntax Scripting: `result = getvalue(_FM, cc)`
`result = getvalue(_MOTFLAG, cc)`

Reply:

$FM = f_1 + f_2 * 2 + f_3 * 4 + \dots + f_n * 2^{n-1}$

Type: Unsigned 16-bit Min: 0 Max: 255

Where:

cc = Motor channel
f1 = Amps Limit currently active
f2 = Motor stalled
f3 = Loop Error detected
f4 = Safety Stop active
f5 = Forward Limit triggered
f6 = Reverse Limit triggered
f7 = Amps Trigger activated

Example:

Q: ?FM 1

R: FM=6 : Motor 1 is stalled and loop error detected

Note:

f2, f3 and f4 are cleared when the motor command is making the motor idle (e.g. 0 in closed loop speed). When f5 or f6 are on, the motor can only be commanded to go in the reverse direction.

FS - Read Status Flags

Alias: STFLAG HexCode: 14 CANOpen id: 0x2111

Description:

Report the state of status flags used by the controller to indicate a number of internal conditions during normal operation. The response to this query is the single number for all status flags. The status of individual flags is read by converting this number to binary and look at various bits of that number.

Syntax Serial: ?FS

Argument: None

Syntax Scripting: `result = getvalue(_FS, 1)`
`result = getvalue(_STFLAG, 1)`

Reply:

$FS = f_1 + f_2 * 2 + f_3 * 4 + \dots + f_n * 2^{n-1}$ Type: Unsigned 16-bit Min: 0 Max: 65535

Where:

f1 = Serial mode

f2 = Pulse mode
f3 = Analog mode
f4 = Power stage off
f5 = Stall detected
f6 = At limit
f7 = Unused
f8 = MicroBasic script running
f9 = Motor/Sensor Tuning mode

Note:

On controller models supporting Spektrum radio mode f4 is used to indicate Spektrum. f4 to f6 are shifted to f5 to f7

HS - Read Hall Sensor States

Alias: HSENSE HexCode: 31 CANOpen id: 0x2123

Description:

Reports that status of the hall sensor inputs. This function is mostly useful for troubleshooting. When no sensors are connected, all inputs are pulled high and the value 7 will be replied. For 60 degrees spaced Hall sensors, 0-1- 3-4- 6-7 are valid combinations, while 2 and 5 are invalid combinations. For 120 degrees spaced sensors, 1-2- 3-4- 5-6 are valid combinations, while 0 and 7 are invalid combinations. In normal conditions, valid values should appear at one time or the other as the motor shaft is rotated

Syntax Serial: ?HS [cc]

Argument: Channel
 Min: 1 Max: Total Number of Motors

Syntax Scripting: result = getvalue(_HS, cc)
 result = getvalue(_HSENSE, cc)

Reply:

HS= ha + 2*hb + 4*hc Type: Unsigned 8-bit Min: 0 Max: 7

Where:

cc = channel
ha = hall sensor A
hb = hall sensor B
hc = hall sensor C

Example:

Q: ?HS 1

R: HS=5 : sensors A and C are high, sensor B is low

Note:

Function not available on HBLxxxxx products

ICL - Is RoboCAN Node Alive

Alias: ICL HexCode: 46 CANOpen id:

Description:

This query is used to determine if specific RoboCAN node is alive on CAN bus.

Syntax Serial: ?ICL cc

Argument: Nodeld
 Min: 1 Max: 127

Syntax Scripting: result = getvalue(_ICL, cc)

Reply:

ICL=nn Type: Unsigned 8-bit Min: 0 Max: 1

Where:

cc = Node Id
nn =
0 : Not present
1 : Alive

K - Read Spektrum Receiver

Alias: SPEKTRUM HexCode: 21 CANOpen id: 0x211A

Description:

On controller models with Spektrum radio support, this query is used to read the raw values of each of up to 6 receive channels. When signal is received, this query returns the value 0.

Syntax Serial: ?K [cc]

Argument: Channel
 Min: 1 Max: 6

Syntax Scripting: result = getvalue(_K, cc)
 result = getvalue(_SPEKTRUM, cc)

Reply:

K=nn Min: 0 Max: 1024

Where:

cc = Radio channel
nn = Raw joystick value, or 0 if transmitter is off or out of range

LK - Read Lock status

Alias: LOCKED HexCode: 1D CANOpen id:

Description:

Returns the status of the lock flag. If the configuration is locked, then it will not be possible to read any configuration parameters until the lock is removed or until the parameters are reset to factory default. This feature is useful to protect the controller configuration from being copied by unauthorized people.

Syntax Serial: ?LK

Argument: None

Syntax Scripting: result = getvalue(_LK, 1)
 result = getvalue(_LOCKED, 1)

Reply:

LK=ff Type: Unsigned 8-bit Min: 0 Max: 1

Where:

ff =
0 : unlocked
1 : locked

M - Read Motor Command Applied

Alias: MOTCMD HexCode: 01 CANOpen id: 0x2101

Description:

Reports the command value that is being used by the controller. The number that is reported will be depending on which mode is selected at the time. The choice of one command mode vs. another is based on the command priority mechanism. In the Serial mode, the reported value will be the command that is entered in via the RS232, RS485, TCP or USB port and to which an optional exponential correction is applied. In the Analog and Pulse modes, this query will report the Analog or Pulse input after it is being converted using the min, max, center, deadband, and linearity corrections. This query is useful for viewing which command is actually being used and the effect of the correction that is being applied to the raw input.

Syntax Serial: ?M [cc]

Argument: Channel
 Min: 1 Max: Total Number of Motors

Syntax Scripting: result = getvalue(_M, cc)
 result = getvalue(_MOTCMD, cc)

Reply:

M=nn Type: Signed 32-bit Min: -2147M Max: 2147M

Where:

cc = Motor channel
nn = Command value used for each motor. 0 to +/-1000 range

Example:

Q: ?M

R: M=800:-1000

Q: ?M 1 R:

M=800

MA - Read Field Oriented Control Motor Amps

Alias: MEMS HexCode: 25 CANOpen id: 0x211C

Description:

On brushless motor controllers operating in sinusoidal mode, this query returns the Torque (also known as Quadrature or Iq) current, and the Flux (also known as Direct, or Id) current. Current is reported in Amps x 10.

Syntax Serial: ?MA nn

Argument: AmpsChannel

Min: 1 Max: 2 * Total Number of Motors

Syntax Scripting: result = getvalue(_MA, nn)

result = getvalue(_MEMS, nn)

Reply:

MA=mm

Type: Signed 16-bit

Where:

nn =

1 : Flux Amps 1 (Id)

2 : Torque Amps 1 (Iq)

3 : Flux Amps 2 (Id)

4 : Torque Amps 2 (Iq)

mm = Amps * 10

MGD - Read MagsensorTrack Detect

Alias: MGDET HexCode: 29 CANOpen id: 0x211D

Description:

When one or more MGS1600 Magnetic Guide Sensors are connected to the controller, this query reports whether a magnetic tape is within the detection range of the sensor. If no tape is detected, the output will be 0. If only one sensor is connected to any pulse input, no argument is needed for this query. If more than one sensor is connected to pulse inputs and these inputs are enabled and configured in Magsensor MultiPWM mode, then the argument following the query is used to select the sensor

Syntax Serial: ?MGD [cc]

Argument: SensorNumber

Min: None

Max: Total Number of Pulse Inputs

Syntax Scripting: result = getvalue(_MGD, cc)

result = getvalue(_MGDET, cc)

Reply:

MGD=nn Type: Unsigned 8-bit Min: 0 Max: 1

Where:

cc = (When only one sensor enabled)
 None or 1 : Current sensor
 cc = (When several sensors enabled)
 1 : Sensor at pulse input 1
 2 : Sensor at pulse input 2
 ...
 p : Sensor at pulse input p
 nn =
 0 : No track detected
 1 : Track detected

MGM - Read Magsensor Markers

Alias: MGMRKR HexCode: 2B CANOpen id: 0x211F

Description:

When one or more MGS1600 Magnetic Guide Sensors are connected to the controller, this query reports whether left or right markers are present under sensor. If only one sensor is connected to any pulse input this query will report the data of that sensor, regardless which pulse input it is connected to. If more than one sensor is connected to pulse inputs and these inputs are enabled and configured in Magsensor MultiPWM mode, then the argument following the query is used to select the sensor

Syntax Serial: ?MGM [cc]

Argument: SensorNumber
 Min: 1 Max: 2 * Total Number of Pulse Inputs

Syntax Scripting: result = getvalue(_MGM, cc)
 result = getvalue(_MGMRKR, cc)

Reply:

MGM=mm Type: Unsigned 8-bit Min: 0 Max: 1

Where:

cc = (When only one sensor enabled)
 1 : Left Marker
 2 : Right Marker
 cc = (When several sensors enabled)
 1 : Left Marker of sensor at pulse input 1
 2 : Right Marker of sensor at pulse input 1
 3 : Left Marker of sensor at pulse input 2
 4 : Right Marker of sensor at pulse input 2
 ...
 ((p-1)* 2)+1 : Left Marker of sensor at pulse input p
 ((p-1)* 2)+2 : Right Marker of sensor at pulse input p
 nn =
 0 : No marker detected
 1 : Marker detected

MGS - Read Magsensor Status

Alias: MGSTATUS HexCode: 2C CANOpen id: 0x2120

Description:

When one or more MGS1600 Magnetic Guide Sensors are connected to the controller, this query reports the state of the sensor. If only one sensor is connected to any pulse input, no argument is needed for this query. If more than one sensor is connected to pulse inputs and these inputs are enabled and configured in Magsensor MultiPWM mode, then the argument following the query is used to select the sensor.

Syntax Serial: ?MGS

Argument: SensorNumber
 Min: None Max: Total Number of Pulse Inputs
 Syntax Scripting: result = getvalue(_MGS,)
 result = getvalue(_MGSTATUS,)

Reply:

MGS=f1 + f2*2 + f3*4 + ... + fn*2n-1 Type: Unsigned 16-bit

Where:

cc = (When only one sensor enabled)
 None or 1 : Current sensor
 cc = (When only several sensors enabled)
 1 : Sensor at pulse input 1
 2 : Sensor at pulse input 2
 ...
 p : Sensor at pulse input p
 f1 : Tape cross
 f2 : Tape detect
 f3 : Left marker present
 f4 : Right marker present
 f9 : Sensor active

MGT - Read Magsensor Track Position

Alias: MGTRACK HexCode: 2A CANOpen id: 0x211E

Description:

When one or more MGS1600 Magnetic Guide Sensors are connected to the controller, this query reports the position of the tracks detected under the sensor. If only one sensor is connected to any pulse input, the argument following the query selects which track to read. If more than one sensor is connected to pulse inputs and these inputs are enabled and configured in Magsensor MultiPWM mode, then the argument following the query is used to select the sensor. The reported position of the magnetic track in millimeters, using the center of the sensor as the 0 reference.

Syntax Serial: ?MGT cc

Argument: Channel
 Min: 1 Max: 3 * Total Number of Pulse Inputs

Syntax Scripting: `result = getvalue(_MGT, cc)`
`result = getvalue(_MGTRACK, cc)`

Reply:

MGM = nn Type: Signed 16-bit

Where:

cc = (When only one sensor enabled)

1 : Left Track

2 : Right Track

3 : Active Track

cc = (When several sensors enabled)

1 : Left Track of sensor at pulse input 1

2 : Right Track of sensor at pulse input 1

3 : Active Track of sensor at pulse input 1

4 : Left Track of sensor at pulse input 2

5 : Right Track of sensor at pulse input 2

6 : Active Track of sensor at pulse input 2

...

$((p-1) * 3)+1$: Left Track of sensor at pulse input p

$((p-1) * 3)+2$: Right Track of sensor at pulse input p

$((p-1) * 3)+3$: Active Track of sensor at pulse input p

nn = position in millimeters

MGY - Read Magsensor Gyroscope

Alias: MGYRO HexCode: 2D CANOpen id: 0x2121

Description:

When one or more MGS1600 Magnetic Guide Sensors are connected to the controller, this query reports the state of the optional gyroscope inside the sensor. If only one sensor is connected to any pulse input, no argument is needed for this query. If more than one sensor is connected to pulse inputs and these inputs are enabled and configured in Magsensor MultiPWM mode, then the argument following the query is used to select the sensor

Syntax Serial: ?MGY [cc]

Argument: Channel]

Min: None

Max: Total Number of Pulse Inputs

Syntax Scripting: `result = getvalue(_MGY, cc)`

`result = getvalue(_MGYRO, cc)`

Reply:

MGY=nn

Type: Signed 16-bit

Min: -32768

Max: 32767

Where:

cc = (When only one sensor enabled)

None or 1 : Current sensor

cc = (When several sensors enabled)

1 : sensor at pulse input 1
2 : sensor at pulse input 2

...

p : sensor at pulse input p
nn = Gyroscope value

MGX - Read MagSensorTape Cross Detection

Alias: - HexCode: 52 CANOpen id: 0x2138

Description:

When one or more MGS1600 Magnetic Guide Sensors are connected to the controller, this query reports the flag of the Tape Cross Detection of the sensor. If only one sensor is connected to any pulse input, no argument is needed for this query. If more than one sensor is connected to pulse inputs and these inputs are enabled and configured in Magsensor MultiPWM mode, then the argument following the query is used to select the sensor.

Syntax Serial: ?MGY [cc]

Argument: Channel

 Min: None Max: Total Number of Pulse Inputs

Syntax Scripting: result = getvalue(_MGY, cc)

Reply:

MGY = aa Type: 1-bit Min: 0 Max: 1

Where:

cc = (When only one sensor enabled)

None or 1 : Current sensor

cc = (When several sensors enabled)

1 : sensor at pulse input 1

2 : sensor at pulse input 2

...

p : sensor at pulse input p

nn = Tape Cross Flag

P - Read Motor Power Output Applied

Alias: MOTPWR HexCode: 02 CANOpen id: 0x2102

Description:

Reports the actual PWM level that is being applied to the motor at the power output stage. This value takes into account all the internal corrections and any limiting resulting from temperature or over current. A value of 1000 equals 100% PWM. The equivalent voltage at the motor wire is the battery voltage * PWM level.

Syntax Serial: ?P [cc]

Argument: Channel
Min: 1 Max: Total Number of Motors

Syntax Scripting: result = getvalue(_P, cc)
result = getvalue(_MOTPWR, cc)

Reply:

P=nn Type: Signed 16-bit Min: -1000 Max: 1000

Where:

cc = Motor channel
nn = 0 to +/-1000 power level

Example:

Q: ?P 1
R: P=800

PHA - Read Phase Amps

Alias: - HexCode: 49 CANOpen id: -

Description:

Measures and reports instant motor phase Amps, in Amps*10, for all current sensors located in the motor phases. Applicable only for brushless and AC Induction motor controllers.

Syntax Serial: ?PHA [cc]

Argument: Channel
Min: 1 Max: Total Number Of Current Sensors

Syntax Scripting: result = getvalue(_PHA, cc)

Reply:

PHA = aa Type: Signed 16-bit Min: -32767 Max: 32767

Where:

cc = Current Sensor
aa = Amps*10

PI - Read Pulse Inputs

Alias: PLSIN HexCode: 11 CANOpen id: 0x6402

Description:

Reports the value of each of the enabled pulse input captures. The value is the raw number in microseconds when configured in Pulse Width mode. In Frequency mode, the returned value is in Hertz. In Duty Cycle mode, the reported value ranges between 0 and 4095 when the pulse duty cycle is 0% and 100% respectively. In Pulse Count mode, the

reported value in the number of pulses as detected. This counter only increments. In order to reset that counter the pulse capture mode needs to be set back to disabled and then again to Pulse Count.

Syntax Serial: ?PI [cc]

Argument: InputNbr
Min: 1 Max: Total Number of Pulse Input

Syntax Scripting: result = getvalue(_PI, cc)
result = getvalue(_PLSIN, cc)

Reply:

PI=nn Type: Unsigned 16-bit Min: 0 Max: 65536

Where:

cc = Pulse capture input number

nn = Value

Note:

The total number of Pulse input channels varies from one controller model to another and can be found in the product datasheet.

PIC - Read Pulse Input after Conversion

Alias: PLSINC HexCode: 24 CANOpen id: 0x6404

Description:

Returns value of a Pulse input after all the adjustments were performed to convert it to a command or feedback value (Min/Max/Center/Deadband/Linearity). If an input is disabled, the query returns 0.

Syntax Serial: ?PIC [cc]

Argument: InputNbr
Min: 1 Max: Total Number of Pulse Input

Syntax Scripting: result = getvalue(_PIC, cc)
result = getvalue(_PLSINC, cc)

Reply:

PIC=nn Type: Signed 16-bit Min: -1000 Max: 1000

Where:

cc = Pulse input number

nn = Converted input value to +/-1000 range

S - Read Encoder Motor Speed in RPM

Alias: ABSPEED HexCode: 03 CANOpen id: 0x2103

Description:

Reports the actual speed measured by the encoders as the actual RPM value. To report RPM accurately, the correct Pulses per Revolution (PPR) must be stored in the encoder configuration

Syntax Serial: ?S [cc]

Argument: Channel
Min: 1 Max: Total Number of Encoders

Syntax Scripting: result = getvalue(_S, cc)
result = getvalue(_ABSPEED, cc)

Reply:

S = nn Type: Signed 32-bit Min: -65535 Max: 65535

Where:

cc = Motor channel
nn = Speed in RPM

SCC - Read Script Checksum

Alias: SCC HexCode: 45 CANOpen id: 0x2133

Description:

Scans the script storage memory and computes a checksum number that is unique to each script. If not script is loaded the query outputs the value 0xFFFFFFFF. Since a stored script cannot be read out, this query is useful for determining if the correct version of a given script is loaded.

Syntax Serial: ?SCC

Argument: None

Syntax Scripting: result = getvalue(_SCC, 1)

Reply:

SCC = nn Type: Unsigned 32-bit

Where:

nn = Checksum number

SNA - Read Sensor Angle

Alias: - HexCode: 79 CANOpen id: -

Description:

On brushless controller operating in sinusoidal mode, this query returns the real time value of the rotor's angle sensor of brushless motor. This query is useful for verifying troubleshooting sin/cos and SPI/SSI sensors. Angle are reported in 0-511 degrees..

Syntax Serial: ?SNA [cc]

Argument: Channel
Min: 1 Max: Total Number Of Motors

Syntax Scripting: result = getvalue(_SNA, cc)

Reply:
SNA = aa Type: Unsigned 16-bit Min: 0 Max: 511

Where:

cc = Motor Channel
aa = Sensor Angle

SR - Read Encoder Speed Relative

Alias: RELSPEED HexCode: 07 CANOpen id: 0x2107

Description:

Returns the measured motor speed as a ratio of the Max RPM (MXRPM) configuration parameter. The result is a value of between 0 and +/1000. As an example, if the Max RPM is set at 3000 inside the encoder configuration parameter and the motor spins at 1500 RPM, then the returned value to this query will be 500, which is 50% of the 3000 max. Note that if the motor spins faster than the Max RPM, the returned value will exceed 1000. However, a larger value is ignored by the controller for its internal operation.

Syntax Serial: ?SR [cc]

Argument: Channel
Min: 1 Max: Total Number of Encoders

Syntax Scripting: result = getvalue(_SR, cc)
result = getvalue(_RELSPEED, cc)

Reply:
SR = nn Type: Signed 16-bit Min: -1000 Max: 1000

Where:

cc = Motor channel
nn = Speed relative to max

SS - Read SSI Sensor Motor Speed in RPM

Alias: - HexCode: 6A CANOpen id: 0x213C

Description:

Reports the actual speed measured by the SSI sensors as the actual RPM value. To report RPM accurately, the correct Counts per Revolution (SCPR) must be stored in the encoder configuration.

Syntax Serial: ?SS [cc]

Argument: Channel
Min: 1 Max: Total Number of SSI sensors

Syntax Scripting: result = getvalue(_SS, cc)

Reply:

SS = aa Type: Signed 32-bit Min: -65535 Max: 65535

Where:

cc = Motor channel

aa = Speed in RPM.

SSR - Read SSI Sensor Speed Relative

Alias: - HexCode: 6B CANOpen id: 0x213D

Description:

Returns the measured motor speed as a ratio of the Max RPM (MXRPM) configuration parameter. The result is a value of between 0 and +/1000. As an example, if the Max RPM is set at 3000 inside the encoder configuration parameter and the motor spins at 1500 RPM, then the returned value to this query will be 500, which is 50% of the 3000 max. Note that if the motor spins faster than the Max RPM, the returned value will exceed 1000. However, a larger value is ignored by the controller for its internal operation.

Syntax Serial: ?SSR [cc]

Argument: Channel
Min: 1 Max: Total Number of SSI sensors

Syntax Scripting: result = getvalue(_SSR, cc)

Reply:

SSR = aa Type: Signed 16-bit Min: -1000 Max: 1000

Where:

cc = Motor channel

aa = Speed relative to max.

STT - STO Self-Test Result

Alias: - HexCode: 70 CANOpen id: -

Description:

Returns the result of the latest executed STO Self-Test process. This process is applicable only on motor controllers with STO circuit implemented on their board. If the result is not successful the Respective STO Fault bit in the Fault Flags is set. The fault is triggered when:

Any of the transistors or other component of the STO circuit is damaged.

The respective jumper is placed on the board.

Syntax Serial: ?STT

Argument: None

Syntax Scripting: result = getvalue(_STT, 1)

Reply:

STT=ff Type Signed 8-bit Min:-1 Max: 4

Where ff=

-1: The test is in process

0: Test successful

1: STO1 failed the test

2: STO2 failed the test

3: Test failed using input values

4: Test passed using input values, but cannot continue test since STO is triggered.

T - Read Temperature

Alias: TEMP HexCode: 12 CANOpen id: 0x210F

Description:

Reports the temperature at each of the Heatsink sides and on the internal MCU silicon chip. The reported value is in degrees C with a one degree resolution.

Syntax Serial: ?T [cc]

Argument: SensorNbr
 Min: 1 Max: Total Number of Motors + 1

Syntax Scripting: result = getvalue(_T, cc)
 result = getvalue(_TEMP, cc)

Reply:

T= cc Type: Signed 8-bit Min: -40 Max: 125

Where:

cc =

1 : MCU temperature

2 : Channel 1 side

3 : Channel 2 side

tt = temperature in degrees

Note:

On some controller models, additional temperature values may be reported. These are measured at different points and not documented. You may safely ignore this extra data. Other controller models only have one heatsink temperature sensor and therefore only report one value in addition to the Internal IC temperature.

TM - Read Time

Alias: TIME HexCode: 1C CANOpen id: 0x2119

Description:

Reports the value of the time counter in controller models equipped with Real-Time clocks with internal or external battery backup. On older controller models, time is counted in a 32-bit counter that keeps track the total number of seconds, and that can be converted into a full day and time value using external calculation. On newer models, the time is kept in multiple registers for seconds, minutes, hours (24h format), dayofmonth, month, year in full

Syntax Serial: ?TM [ee]

Argument: Element
 Min: None Max: 6

Syntax Scripting: result = getvalue(_TM, ee)
 result = getvalue(_TIME, ee)

Reply:

TM = nn Type: Unsigned 32-bit Min: 0

Where:

ee = date element in new controller model

1 : Seconds
 2 : Minutes
 3 : Hours (24h format)
 4 : Dayofmonth
 5 : Month
 6 : Year in full
 nn = Value

TR - Read Position Relative Tracking

Alias: TRACK HexCode: 20 CANOpen id:

Description:

Reads the real-time value of the expected motor position in the position tracking closed loop mode and in speed position

Syntax Serial: ?TR [cc]

Argument: Channel
 Min: 1 Max: Total Number of Motors

Syntax Scripting: result = getvalue(_TR, cc)
 result = getvalue(_TRACK, cc)

Reply:

TR=nn Type: Signed 32-bit Min: -2147M Max: 2147M

Where:

cc = Motor channel
nn = Position

TRN - Read Control Unit type and Controller Model

Alias: TRN HexCode: 1F CANOpen id:

Description:

Reports two strings identifying the Control Unit type and the Controller Model type. This query is useful for adapting the user software application to the controller model that is attached to the computer.

Syntax Serial: ?TRN

Argument: None

Syntax Scripting: result = getvalue(_TRN, 1)

Reply:

TRN=ss Type: String

Where:

ss = Control Unit Id String:Controller Model Id String

Example:

Q: ?TRN
R:TRN=RCB500:HDC2460

UID - Read MCU Id

Alias: UID HexCode: 32 CANOpen id:

Description:

Reports MCU specific information. This query is useful for determining the type of MCU: 100 = STM32F10X, 300 = STM32F30X. The query also produces a unique Id number that is stored on the MCU silicon.

Syntax Serial: ?UID [ee]

Argument: Element
Min: 1 Max: 5

Syntax Scripting: result = getvalue(_UID, ee)

Reply:

UID = nn Type: Unsigned 32-bit Min: 1 Max: 4294M

Where:

ee = Data element
 1 : MCU type
 2 : MCU Device Id
 3-5 : MCU Unique ID
 nn = value

V - Read Volts

Alias: VOLTS HexCode: 0D CANOpen id: 0x210D

Description:

Reports the voltages measured inside the controller at three locations: the main battery voltage, the internal voltage at the motor driver stage, and the voltage that is available on the 5V output on the DSUB 15 or 25 front connector. For safe operation, the driver stage voltage must be above 12V. The 5V output will typically show the controller's internal regulated 5V minus the drop of a diode that is used for protection and will be in the 4.7V range. The battery voltage is monitored for detecting the undervoltage or overvoltage conditions.

Syntax Serial: ?V [ee]

Argument: SensorNumber
 Min: 1 Max: 3

Syntax Scripting: result = getvalue(_V, ee)
 result = getvalue(_VOLTS, ee)

Reply:

V = nn Type: Unsigned 16-bit

Where:

ee =
 1 : Internal volts
 2 : Battery volts
 3 : 5V output
 nn = Volts * 10 for internal and battery volts. Millivolts for 5V output

Example:

Q: ?V
 R:V=135:246:4730
 Q: ?V 3
 R:V=4730

VAR - Read User Integer Variable

Alias: VAR HexCode: 06 CANOpen id: 0x2106

Description:

Read the value of dedicated 32-bit internal variables that can be read and written to/from within a user MicroBasic script. It is used to pass 32-bit signed number between user scripts and a microcomputer connected to the controller. The total number of user integer variables varies from one controller model to another and can be found in the product datasheet.

Syntax Serial: ?VAR [ee]

Argument: VarNumber
 Min: 1 Max: Total Number of User Variables

Syntax Scripting: result = getvalue(_VAR, ee)

Reply:

VAR=nn Type: Signed 32-bit Min: -2147M Max: 2147M

Where:

ee = Variable number

nn = Value

SL - Read Slip Frequency

Alias: SL HexCode: 48 CANOpen id: 0x2136

Description:

This query is only used in AC Induction boards. Read the value of the Slip Frequency between the rotor and the stator of an AC Induction motor.

Syntax Serial: ?SL [cc]

Argument: VarNumber
 Min: 1 Max: Total Number of Motors

Syntax Scripting: result = getvalue(_SL, cc)

Reply:

SL=nn Type: Signed 16-bit Min: -32768 Max: 32768

Where:

cc = Motor channel

nn = Slip Frequency in Hertz * 10

DS402 Runtime Queries

Runtime queries created to support DS402 specification are described below:

TABLE 15-11.

Command	Arguments	Description
AOM	Channel	Modes of Operation Display (DS402)
CW	Channel	Control Word (DS402)
F	Channel	Velocity/Position Actual Value (DS402)

Command	Arguments	Description
PAC	Channel	Profile Acceleration (DS402)
PDC	Channel	Profile Deceleration (DS402)
POS	Channel	Target Position (DS402)
PSP	Channel	Profile Velocity (DS402)
RMP	Channel	Velocity Demand (DS402)
ROM	Channel	Modes of Operation (DS402)
S	Channel	Target Velocity (DS402)
SAC	Element	Velocity Acceleration (DS402)
SDC	Element	Velocity Deceleration (DS402)
SDM	None	Supported Drive Modes (DS402)
SPL	Element	Velocity Min/Max Amount (DS402)
SW	Channel	Status Word (DS402)
TC	Channel	Target Torque (DS402)
TRQ	Channel	Torque Actual Value (DS402)
TSL	Channel	Torque Slope (DS402)
VNM	None	Version Number (DS402)

AOM – Modes of Operation Display (DS402)

Alias: AOM HexCode: 63 CANOpen id: 0x6061

Description:

Read the actual operation mode.

Syntax Serial: ?AOM [cc]

Reply: AOM=nn

Syntax Scripting: nn = GetValue(_ROM, cc)

Argument: Channel Type: Unsigned 8-bit

Min: 1 Max: Total number of motors

Result: Value Type: Signed 8-bit

Where:

cc = Motor channel

nn = Actual operation mode

CW – Control Word (DS402)

Alias: CW HexCode: 56 CANOpen id: 0x6040

Description:

Read the value of the control word.

Syntax Serial: ?CW [cc]

Reply: CW=nn

Syntax Scripting: nn = GetValue(_CW, cc)

Argument: Channel Type: Unsigned 8-bit

Min: 1 Max: Total number of motors

Result: Value Type: Unsigned 16-bit

Where:

cc = Motor channel

nn = Control word value

F – Velocity/Position Actual Value (DS402)

Alias: F HexCode: 13 CANOpen id: 0x6044, 0x6064, and 0x606C

Description:

Reads the velocity actual value in RPM if it isn't in Position mode. In Closed Loop Count Position mode, the query reports the position in sensor count. In Closed Loop Position Relative mode and in Closed Loop Tracking Position mode, the position is provided in rang -1000 to 1000 scaled by the minimum and maximum sensor value.

Syntax Serial: ?F [cc]

Reply: F=nn

Syntax Scripting: nn = GetValue(_F, cc)

Argument: Channel Type: Unsigned 8-bit

Min: 1 Max: Total number of motors

Result: Value Type: Signed 32-bit

Where:

cc = Motor channel

nn = Velocity/position actual value

PAC – Profile Acceleration (DS402)

Alias: PAC HexCode: 5E CANOpen id: 0x6083

Description:

Read the configured acceleration in 10×RPM/second.

Syntax Serial: ?PAC [cc]

Reply: PAC=nn

Syntax Scripting: nn = SetCommand(_PAC, cc)

Argument: Channel Type: Unsigned 8-bit

 Min: 1 Max: Total number of motors

Result: Value Type: Unsigned 32-bit

Where:

cc = Motor channel

nn = Profile acceleration in 10×RPM/second

PDC – Profile Deceleration (DS402)

Alias: PDC HexCode: 5F CANOpen id: 0x6084

Description:

Read the configured deceleration in 10×RPM/second.

Syntax Serial: ?PDC [cc]

Reply: PDC=nn

Syntax Scripting: nn = GetValue(_PDC, cc)

Argument: Channel Type: Unsigned 8-bit

 Min: 1 Max: Total number of motors

Result: Value Type: Unsigned 32-bit

Where:

cc = Motor channel

nn = Profile deceleration in 10×RPM/second

POS – Target Position (DS402)

Alias: POS HexCode: 5C CANOpen id: 0x607A

Description:

Read the configured target position.

Syntax Serial: ?POS [cc]

Reply: POS=nn

Syntax Scripting: nn = GetValue(_POS, cc)

Argument: Channel Type: Unsigned 8-bit

 Min: 1 Max: Total number of motors

Result: Value Type: Signed 32-bit

Where:

cc = Motor channel

nn = Target position

PSP – Profile Velocity (DS402)

Alias: PSP HexCode: 5D CANOpen id: 0x6081

Description:

Read the configured velocity in RPM.

Syntax Serial: ?PSP [cc]

Reply: PSP=nn

Syntax Scripting: nn = GetValue(_PSP, cc)

Argument: Channel Type: Unsigned 8-bit

Min: 1 Max: Total number of motors

Result: Value Type: Unsigned 16-bit

Where:

cc = Motor channel

nn = Profile velocity

RMP – VL Velocity Demand (DS402)

Alias: RMP HexCode: 62 CANOpen id: 0x6043

Description:

Read the instantaneous velocity in RPM generated by the ramp function. Positive values shall indicate forward direction and negative values shall indicate reverse direction.

Syntax Serial: ?RMP [cc]

Reply: RMP=nn

Syntax Scripting: nn = GetValue(_RMP, cc)

Argument: Channel Type: Unsigned 8-bit

Min: 1 Max: Total number of motors

Result: Value Type: Signed 32-bit

Where:

cc = Motor channel

nn = Velocity in RPM

ROM – Modes of Operation (DS402)

Alias: ROM HexCode: 5A CANOpen id: 0x6060

Description:

Read the configured modes of operation.

Syntax Serial: ?ROM [cc]

Reply: ROM=nn

Syntax Scripting: nn = GetValue(_ROM, cc)

Argument: Channel Type: Unsigned 8-bit

Min: 1 Max: Total number of motors

Result: Value Type: Signed 8-bit

Where:

cc = Motor channel

nn = Modes of operation

S – Target Velocity (DS402)

Alias: MOTVEL HexCode: 03 CANOpen id: 0x6042, 0x60FF

Description:

Read the target velocity in RPM. Positive values shall indicate forward direction and negative values shall indicate reverse direction.

Syntax Serial: ?S [cc]

Reply: S=nn

Syntax Scripting: nn = GetValue(_S, cc)

nn = GetValue(_MOTVEL, cc)

Argument: Channel: Type: Unsigned 8-bit

Min: 1 Max: Total number of motors

Result: Value Type: Signed 16-bit

Min: -500000 Max: 500000

Where:

cc = Motor channel

nn = Target velocity in RPM

SAC – Velocity Acceleration (DS402)

Alias: SAC HexCode: 58 CANOpen id: 0x6048

Description:

Read the configured velocity acceleration.

Syntax Serial: ?SAC [ee]

Reply: SAC=nn

Syntax Scripting: nn = GetValue(_SAC, ee)

Argument: Element Type: Unsigned 8-bit

 Min: 1 Max: 2 × Total number of motors

Result: Value Type: Unsigned 32-bit

Where:

ee =

1: Delta speed in 10×RPM for channel 1

2: Delta time in seconds for channel 1

3: Delta speed in 10×RPM for channel 2

4: Delta time in seconds for channel 2

...

2 × (m - 1) + 1: Delta speed in 10×RPM for channel m.

2 × (m - 1) + 1: Delta time in seconds for channel m.

nn = Delta speed/time

SDC – Velocity Deceleration (DS402)

Alias: SDC HexCode: 59 CANOpen id: 0x6049

Description:

Read the configured velocity deceleration.

Syntax Serial: ?SDC [ee]

Reply: SDC=nn

Syntax Scripting: nn = GetValue(_SDC, ee)

Argument: Element Type: Unsigned 8-bit

 Min: 1 Max: 2 × Total number of motors

Result: Value Type: Unsigned 32-bit

Where:

ee =

- 1: Delta speed in 10×RPM for channel 1
- 2: Delta time in seconds for channel 1
- 3: Delta speed in 10×RPM for channel 2
- 4: Delta time in seconds for channel 2
- ...
- $2 \times (m - 1) + 1$: Delta speed in 10×RPM for channel m.
- $2 \times (m - 1) + 1$: Delta time in seconds for channel m.
- nn = Delta speed/time

SDM – Supported Drive Modes (DS402)

Alias: SDM HexCode: 64 CANOpen id: 0x6502

Description:

Read the supported drive modes. Roboteq controllers support the following modes:

- Profile Position Mode (PP).
- Velocity Mode (VL).
- Profile Velocity Mode (PV).
- Torque Mode (TQ).

Syntax Serial: !SDM

Reply: SDM=nn

Syntax Scripting: nn = GetValue(_TSL)

Result: Value Type: Unsigned 32-bit

Where:

nn = Supported drive modes

SPL – Velocity Min/Max Amount (DS402)

Alias: SPL HexCode: 57 CANOpen id: 0x6046

Description:

Read the configured minimum and maximum amount of velocity in RPM.

Syntax Serial: ?SPL [ee]

Reply: SPL=nn

Syntax Scripting: nn = GetValue(_SPL, ee)

Argument: Eelment Type: Unsigned 8-bit

Min: 1 Max: 2 × Total number of motors

Result: Value Type: Unsigned 32-bit

Where:

ee =

1: Min amount for channel 1

2: Max amount for channel 1

3: Min amount for channel 2

4: Max amount for channel 2

...

$2 \times (m - 1) + 1$: Min amount for channel m.

$2 \times (m - 1) + 1$: Max amount for channel m.

nn = Velocity max/min amount

SW – Status Word (DS402)

Alias: SW HexCode: 61 CANOpen id: 0x6041

Description:

Read the status of the PDS FSA.

TABLE 15-12. Status Word Mapping

15	14	13	12	11	10	9	8	7	6	5	4	3	2	1	0
NU	OMS	ILA	TR	RM	MS	W	SOD	QS	VE	F	OE	SO	RTSO		
MSB														LSB	
NU → Not Used, OMS → Operation mode specific, ILA → Internal limit active TR → Target reached, RM → Remote, W → Warning, SOD → Switch on disabled, QS → Quick stop, VE → Voltage enabled, F → Fault, OE → Operation Enabled, SO → Switch on RTSO → Ready to switch on.															

If bit 4 (voltage enabled) of the status word is always 1. If bit 5 (quick stop) of the status word is 0, this shall indicate that the PDS is reacting on a quick stop request (quick stop mode is always 2). Bit 7 (warning) is always 0. Bit 9 (remote) of the status word is always 1. If bit 10 (target reached) of the status word is 1, this shall indicate that the PDS has reached the set-point. Bit 10 shall also be set to 1, if the operation mode has been changed. The change of a target value by software shall alter this bit. If halt occurred and the PDS has halted then bit 10 shall be set to 1, too. If the same internal value is commanded then bit 10 shall not alter, if bit 10 is supported (see Table 10). If bit 11 (internal limit active) of the status word is 1, this shall indicate that current limit has been reached.

TABLE 15-13. State Coding

Status Word	PDS FSA state
xxxx xxxx x0xx 0000 _b	Not ready to switch on
xxxx xxxx x1xx 0000 _b	Switch on disabled
xxxx xxxx x01x 0001 _b	Ready to switch on
xxxx xxxx x01x 0011 _b	Switched on
xxxx xxxx x01x 0111 _b	Operation enabled
xxxx xxxx x00x 0111 _b	Quick stop active
xxxx xxxx x0xx 1111 _b	Fault reaction active
xxxx xxxx x0xx 1000 _b	Fault

TABLE 15-10. Definition of Bit 10

Bit	Value	Definition
10	0	Halt (bit 8 in control word) = 0: Speed or Position Target not reached Halt (bit 8 in control word) = 1: Axis decelerates
	1	Halt (bit 8 in control word) = 0: Speed or Position Target reached Halt (bit 8 in control word) = 1: Velocity of axis is 0

Profile Position Mode

TABLE 15-14. Status Word Mapping in Profile Position Mode

15	14	13	12	11	10	9	0	
see Table 8	Not Used	Set-Point Acknowledge	see Table 8	Target Reached	see Table 8			
MSB								LSB

In Profile Position Mode the operation specific bits are mapped in Table 15-14. Status Word Mapping in Profile Position Mode with bits 10 and 12 user can acknowledge the status of the controller as shown in Table 10 and Table 12. Bit 13 is always 0.

TABLE 15-15. Definition of Bit 12 in Profile Position Mode

Bit	Value	Definition
12	0	Previous set-point already processed, waiting for new set-point
	1	Previous set-point still in process, set-point overwriting shall be accepted

Profile Velocity Mode

TABLE 15-16. Status Word Mapping in Profile Velocity Mode

15	14	13	12	11	10	9	0	
see Table 12	Not Used	Speed	see Table 12	Target Reached	see Table 12			
MSB								LSB

In Profile Velocity Mode the operation specific bits are mapped in Table 11 with bits 10 and 12 user can acknowledge the status of the controller as shown in Table 10 and Table 14. Bit 13 is always 0.

TABLE 15-17. Definition of Bit 12 in Profile Velocity Mode

Bit	Value	Definition
12	0	Speed is not equal 0
	1	Speed is equal 0

Syntax Serial: ?SW [cc]

Reply: SW=nn

Syntax Scripting: nn = GetValue(_SW, cc)

Argument: Channel Type: Unsigned 8-bit

Min: 1 Max: Total number of motors

Result: Value Type: Unsigned 16-bit

Where:

cc = Motor channel

nn = Status word value

TC – Target Torque (DS402)

Alias: TC HexCode: 5B CANOpen id: 0x6071

Description:

Read the configured target torque in 100×Nm when the controller in torque mode.

Syntax Serial: ?TC [cc]

Reply: TC=nn

Syntax Scripting: nn = GetValue(_TC, cc)

Argument: Channel Type: Unsigned 8-bit

Min: 1 Max: Total number of motors

Result: Value Type: Signed 16-bit

Where:

cc = Motor channel

nn = Torque input value in 100×Nm

TRQ – Target Torque (DS402)

Alias: TRQ HexCode: 7A CANOpen id: 0x6077

Description:

Read the actual torque in 100×Nm.

Syntax Serial: ?TRQ [cc]

Reply: TRQ=nn

Syntax Scripting: nn = GetValue(_TRQ, cc)

Argument: Channel Type: Unsigned 8-bit

Min: 1 Max: Total number of motors

Result: Value Type: Signed 16-bit

Where:

cc = Motor channel

nn = Actual torque 100×Nm

TSL – Profile Acceleration (DS402)

Alias: TSL HexCode: 60 CANOpen id: 0x6087

Description:

Read the configured rate of change of torque, in 10×miliNm/second as long as the Torque Constant (TNM) is 1000 miliNm/A.

Syntax Serial: !TSL [cc]

Reply: TSL=nn

Syntax Scripting: nn = GetValue(_TSL, cc)

Argument: Channel Type: Unsigned 8-bit

Min: 1 Max: Total number of motors

Result: Value Type: Unsigned 32-bit

Where:

cc = Motor channel

nn = Torque slope

VNM – Version Number (DS402)

Alias: VNM HexCode: 65 CANOpen id: 0x67FE

Description:

Read the version number of the CiA 402 profile.

Syntax Serial: !VNM

Reply: VNM=nn

Syntax Scripting: nn = GetValue(_TSL)

Result: Value Type: Unsigned 32-bit

Where:

nn = Version number

Query History Commands

Every time a Real Time Query is received and executed, it is stored in a history buffer from which it can be recalled. The buffer will store up to 16 queries. If more than 16 queries are received, the new one will be added to the history buffer while the firsts are removed in order to fit the 16 query buffer.

Queries can then be called from the history buffer using manual commands, or automatically, at user selected intervals. This feature is very useful for monitoring and telemetry.

Additionally, the history buffer can be loaded with a set of user selected queries at power on so that the controller can automatically issue operating values immediately after power up. See "TELS - Telemetry String" configuration command for details on how to set up the startup Telemetry string. Another feature is the streams. In this case the data can be printed after a prefix and separated with a delimiter. In order to enable a stream, the special character "/" needs to be typed in front of the first query.

A command set is provided for managing the history buffer. These special commands start with a "#" character.

TABLE 15-18. Query History Commands

Command	Description
#	Send the next value. Stop automatic sending
# C	Clear buffer history
# nn	Start automatic sending
# xx nn	Start automatic sending for specific stream
/" <prefix>"; <delimiter>"?Q cc	Create data streams
//?	Dump the streams' prefixes and delimiters

- Send Next History Item / Stop Automatic Sending

A # alone will call and execute the next query in the buffer. If the controller was in the process of automatically sending queries from the buffer, then receiving a # will cause the sending to stop.

When a query is executed from the history buffer, the controller will only display the query result (e.g. A=10:20). It will not display the query itself.

Syntax:

#

Reply: **QQ**

Where:

QQ = is reply to query in the buffer.

C - Clear Buffer History

This command will clear the history buffer of all queries that may be stored in it. If the controller was in the process of automatically sending queries from the buffer, then receiving this command will also cause the sending to stop

Syntax:

C

Reply: None

nn - Start Automatic Sending

This command will initiate the automatic retrieving and execution of queries from the history buffer. The number that follows the command is the time in milliseconds between repetition. A single query is fetched and executed at each time interval.

Syntax:

nn

Reply: **QQ** at every nn time intervals

Where:

QQ = is reply to query in the buffer.
nn = time in ms

Range: **nn** = 1 to 32000ms

xx nn - Start automatic sending for specific stream

Using this syntax one can set the refresh rate of each stream. This is used only in case of using streams.

Syntax:

xx nn

Reply: The respective stream at every nn ms.

Where:

xx = the stream.
nn = time in ms.

/?Q cc - Create data streams

Using this syntax the next queries that are going to be sent will be printed after a prefix and separated by a delimiter. The default prefix is none and the default delimiter is tab. There can be created up to 3 streams and can have different refresh rates.

Syntax:

/"<prefix>"<delimiter>"?Q cc

Reply: The regular reply of the query ?Q cc.

Where:

Q = is reply the query symbol.

cc = motor channel

prefix = the prefix for the stream

delimiter = the delimiter for the stream

For example, if one wants a log of the Motor Power(P), Motor Amps(A) and Encoder Speed(S) of channel 1, with refresh rate 50ms, prefix "d=" and delimiter ':' they should type:

/"d=":"?p 1_?a 1_?s 1_# 50

Two more stream examples are shown below:

/"f=":"?t 1_?v 2_?v 3_# 100

/?p 1_?f 1_?e 1_# 200

The outcome of these three streams are shown in the image below:

The screenshot shows a control interface with two main panels: 'Out Data' and 'Controller Log'.

Out Data Panel: Contains a list of command input fields, each with a 'Send' button. The commands entered are:

- /"d=":"?p 1_?a 1_?s 1_# 50
- /"f=":"?t 1_?v 2_?v 3_# 100
- /?p 1_?f 1_?e 1_# 200
- (Empty)
- (Empty)
- (Empty)
- (Empty)
- lg 1 300
- //?
- # c

 A 'Stop' button is located at the bottom right of this panel.

Controller Log Panel: Displays the output of the commands. The log shows a repeating pattern of data for three different streams:

- Stream 1 (Prefix "d="): D=1000:6:0
- Stream 2 (Prefix "f="): F=26:137:4958, 1000 2405 706
- Stream 3 (Prefix "p="): P=25:136:4956, 1000 2485 706

 The log also shows a 'Time' section at the bottom with 'Get' and 'Set' buttons.

In order to clear the streams # c can be sent and then, the legacy history method can be used. In order to stop the streams but not delete them send #. then using command # xx nn one can restart the streams with nn refresh rate.

//? - Dump the streams' prefixes and delimiters

Using this syntax one can see in each of the 3 streams which prefix and delimiter is set. In that case one can know which stream respects to each stream number.

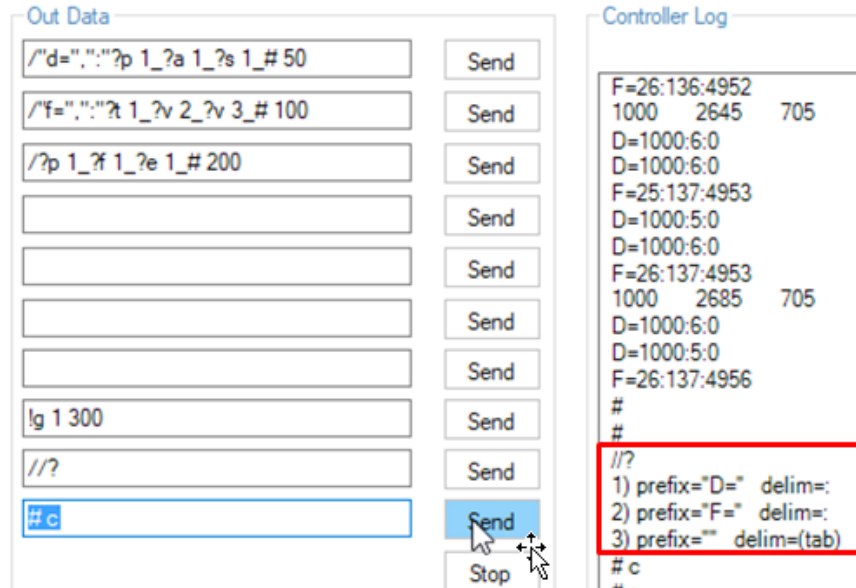

Maintenance Commands

This section contains a few commands that are used occasionally to perform maintenance functions.

TABLE 15-19. Maintenance Commands

Command	Arguments	Description
CLMOD	None	Motor/Sensor Setup
CLRST	Key	Reset configuration to factory defaults
CLSAV	Key	Save calibrations to Flash
DFU	Key	Update Firmware via USB
EELD	None	Load Parameters from EEPROM
EELOG	None	Dump Flash Log Data
EERST	Key	Reset Factory Defaults
EESAV	None	Save Configuration in EEPROM
ERASE	None	Erase Flash Log Data
LK	Key	Lock Configuration Access
RESET	Key	Reset Controller
SLD	Key	Script Load
STIME	Time	Set Time
UK	Key	Unlock Configuration Access

CLMOD – Motor/Sensor Setup

Argument: None

Description:

This command is used in order to perform motor and/or sensor setup, in cases of DC brushless motor controllers, when working in Sinusoidal mode or in Sensorless mode. This command will make the motor spin either slowly (sinusoidal) or even fast (sensorless) and will configure accordingly the respective fields in order to have a smooth motor spin and alignment between the motor and the sensor directions. During setup no motor command can be applied to the motors. For more details see Section 8.

Note: The motor will spin.

Syntax: %CLMOD nn

Where:

0: Exit/Stop Setup Mode.

2: Setup channel 1.

3: Setup channel 2.

CLRST - Reset configuration to factory defaults

Argument: Key

Description:

This command resets all configurations to their factory default

Syntax:

%CLRST safetykey

Where:

safetykey = 321654987

CLSAV - Save calibrations to Flash

Argument: Key

Description:

Saves changes to calibration to Flash. Calibration parameters are stored permanently until new values are stored.. This command must be used with care and must be followed by a 9-digit safety key to prevent accidental use.

Syntax:

%CLSAV safetykey

Where:

safetykey = 321654987

DFU - Update Firmware via USB

Argument: Key

Description:

Firmware update can be performed via the RS232 port or via USB. When done via USB, the DFU command is used to cause the controller to enter in the firmware upgrade mode. This command must be used with care and must be followed by a 9-digit safety key to prevent accidental use. Once the controller has received the DFU command, it will no longer respond to the PC utility and no longer be visible on the PC. When this mode is entered, you must launch the separate upgrade utility (DFULoader) to start the firmware upgrade process.

Syntax:

%DFU safetykey

Where:

safetykey = 321654987

EELD - Load Parameters from EEPROM

Argument: None

Description:

This command reloads the configuration that are saved in EEPROM back into RAM and activates these settings.

Syntax:

%EELD

EELOG - Dump Flash Log Data

Argument: None

Description:

This command is used in order to Dump the Flash Log Data. Each data entry is printed in a row with each value to be separated with a tab. The values, that are going to be printed, are the following:

- timestamp (miliseconds since power-up),
- maximum absolute motor current since the time of the previous entry,
- maximum battery voltage since the time of the previous entry,
- maximum heatsink temperature since the time of the previous entry and
- Fault Flags that have caused the entry.

Each entry is saved to flash at every new fault or every 10 minute when a fault is active.

Note: Flash Log Data are not working when any of the motor channels are configured in resolver sinusoidal mode.

Syntax: %EELOG

EERST - Reset Factory Defaults

Argument: Key

Description:

The EERST command will reload the controller's RAM and EEPROM with the factory default configuration. Beware that this command may cause the controller to no longer work in your application since all your configurations will be erased back to factory defaults. This command must be used with care and must be followed by a 9-digit safety key to prevent accidental use.

Syntax:

%EERST safetykey

Where:

safetykey = 321654987

EESAV - Save Configuration in EEPROM

Argument: None

Description:

Controller configuration that have been changed using any Configuration Command can then be saved in EEPROM. Once in EEPROM, it will be loaded automatically in the controller every time the unit is powered on. If the EESAV command is not called after changing a configuration, the configuration will remain in RAM and active only until the controller is turned off. When powered on again, the previous configuration that was in the EEPROM is loaded. This command uses no parameters

Syntax:

%EESAV

ERASE - Erase Flash Log Data

Argument:None

Description:

This command is used in order to Erase the Flash Log Data.

Syntax: %ERASE

LK - Lock Configuration Access

Argument: Key

Description:

This command is followed by any user-selected secret 32-bit number. After receiving it, the controller will lock the configuration and store the key inside the controller, in area which cannot be accessed. Once locked, the controller will no longer respond to configuration reads. However, it is still possible to store or to set new configurations.

Syntax:

%LK secretkey

Where:

secretkey = 32-bit number (1 to 4294967296)

RESET - Reset Controller

Argument: Key

Description:

This command will cause the controller to reset similarly as if it was powered OFF and ON. This command must be used with care and must be followed by a 9-digit safety key to prevent accidental reset.

Syntax:

%RESET safetykey

Where:

safetykey = 321654987

SLD - Script Load

Argument: Key

Description:

After receiving this command, the controller will enter the script loading mode. It will reply with HLD and stand ready to accept script bytecodes in intel Hex Format. The exact download and data format is described in the MicroBasic section of the manual

Syntax:

%SLD

STIME - Set Time

Argument: Hours Mins Secs

Description:

This command sets the time inside the controller's clock that is available in some controller models. The clock circuit will then keep track of time as long as the clock remains under power. On older controller models, the clock is a single 32-bit counter in which the number of seconds from a preset day and time is stored (for example 02/01/00 at 3:00). On newer model, the clock contains 6 registers for seconds, dates, minutes, hours, day-of-month, month, year. The command syntax will be different for each of these models.

Syntax:

%STIME nn : Older models %STIME ee nn : Newer models

Where:

Older models: nn = number of seconds
Newer models: ee = 1: Seconds 2: Minutes 3: Hours (24h format) 4: Day of month 5: Month 6: Year in full
nn = Value

UK - Unlock Configuration Access

Argument: Key

Description:

This command will release the lock and make the configuration readable again. The command must be followed by the secret key which will be matched by the controller internally against the key that was entered with the LK command to lock the controller. If the keys match, the configuration is unlocked and can be read.

Syntax:
%UK secretkey

Where:
secretkey = 32-bit number (1 to 4294967296)

Set/Read Configuration Commands

These commands are used to set or read all the operating parameters needed by the controller for its operation. Parameters are loaded from EEPROM into RAM, from where they are and then used every time the controller is powered up or restarted.

Important Notices

The total number of configuration parameters is very large. To simplify the configuration process and avoid errors, it is highly recommended to use the RoborunPlus PC utility to read and set configuration.

Some configuration parameters may be absent depending on the presence or absence of the related feature on a particular controller model.

Setting Configurations

The general format for setting a parameter is the “^” character followed by the command name followed by parameter(s) for that command. These will set the parameter in the controller’s RAM and this parameter becomes immediately active for use. The parameter can also be permanently saved in EEPROM by sending the **%EESAV** maintenance command.

Some parameters have a unique value that applies to the controller in general. For example, overvoltage or PWM frequency. These configuration commands are therefore followed by a single parameter:

^PWM 180 : Sets PWM frequency to 18.0 kHz

^OVL 400 : Sets Overvoltage limit to 40.0V

Other parameters have multiple value, with typically one value applying to a different channel. Multiple value parameters are numbered from 1 to n. For example, Amps limit for a motor channel or the configuration of an analog input channel.

^ALIM 1 250 : Sets Amps limit for channel 1 to 25.0A

^AMIN 4 2000 : Sets low range of analog input 4 to 2000

Using 0 as the first parameter value will cause all elements to be loaded with the same content.

^ADB 0 10 : Sets the deadband of all analog inputs to 10%

Important Notice

Saving configuration into EEPROM can take up to 20ms per parameter. The controller will suspend the loop processing during this time, potentially affecting the controller operation. Avoid saving configuration to EEPROM during motor operation.

Reading Configurations

Configuration parameters are read by issuing the “~” character followed by the command name and with an optional channel number parameter. If no parameter is sent, the controller will give the value of all channels. If a channel number is sent, the controller will give the value of the selected channel.

The reply to parameter read command is the command name followed by “=” followed by the parameter value. When the reply contains multiple values, then the different values are separated by “:”. The list below describes every configuration command of the controller. For Example:

~ALIM : Read Amps limit for all channels

Reply: ALIM= 750:650

~ALIM 2: Read Amps limit for channel 2

Reply: ALIM= 650

Configuration parameters can be read from within a MicroBasic script using the getconfig() function. The setconfig() function is used to load a new value in a configuration parameter.

Important Warning

Configuration commands can be issued at any time during controller operation. Beware that some configuration parameters can alter the motor behavior. Change configurations with care. Whenever possible, change configurations while the motors are stopped.

Configuration Read Protection

The controller may be locked to prevent the configuration parameters to be read. Given the large number of possible configurations, this feature provides effective system-level copy protection. The controller will reply to configuration read requests only if the read protection is unlocked. If locked, the controller will respond a “-” character.

General Configuration and Safety

The commands in this group are used to configure the controller’s general and safety settings.

TABLE 15-20. General and Safety Configurations

Command	Arguments	Description
ACS	Enable	Analog Center Safety
AMS	Enable	Analog within Min & Max Safety
BEE	Address Value	User Storage in Battery Backed RAM
BRUN	Enable	MicroBasic Auto Start
CLIN	Channel Linearity	Command Linearity
CPRI	Level Command	Command Priorities
DFC	Channel Value	Default Command value
DMOD	Mode	Modbus Mode

Command	Arguments	Description
ECHOF	OffOn	Enable/Disable Serial Echo
EE	Address Data	Store User Data in Flash
MDAL	Option	Modbus Data Alignment
MNOD	ID	Modbus Node ID
RS485	Enable	Enable RS485
RSBR	BitRate	Set RS232 bit rate
RWD	Timeout	Serial Data Watchdog
SCRO	Port	Select Print output port for scripting
SKCTR	Channel Center	Spektrum Center
SKDB	Channel Deadband	Spektrum Deadband
SKLIN	Channel Linearity	Spektrum Linearity
SKMAX	Channel Max	Spektrum Max
SKMIN	Channel Min	Spektrum Min
SKUSE	Channel Port	Assign Spektrum port to motor command
STO	Enable	Safe Torque Off
TELS	String	Telemetry string

ACS - Analog Center Safety

HexCode: 0B

Description:

This parameter enables the analog safety that requires that the input be at zero or centered before it can be considered as good. This safety is useful when operating with a joystick and requires that the joystick be centered at power up before motors can be made to run. On multi-channel controllers, this configuration acts on all analog command inputs, meaning that all joysticks must be centered before any one becomes active.

Syntax Serial: ^ACS nn
~ACS

Syntax Scripting: setconfig(_ACS, nn)

Number of Arguments: 1

Argument 1: Enable

Type: Unsigned 8-bit
Min: 0 Max: 1
Default: 1

Where:

nn =

0: Safety disabled

1: Safety enabled

AMS - Analog within Min & Max Safety

HexCode: 0C

Description:

This configuration is used to make sure that the analog input command is always within a user preset minimum and maximum safe value. It is useful to detect, for example, that the wire connection to a command potentiometer is broken. If the safety is enabled and the input is outside the safe range, the Analog input command will be considered invalid. The controller will then apply a motor command based on the priority logic..

Syntax Serial: ^AMS nn
 ~AMS

Syntax Scripting: setconfig(_AMS, nn)

Number of Arguments: 1

Argument 1: Enable

Type: Unsigned 8-bit
 Min: 0
 Default: 1 = Enabled
 Max: 1

Where:

nn =
 0: Disabled
 1: Enabled

BEE - User Storage in Battery Backed RAM

HexCode: 64

Description:

Store and retrieve user data in battery backed RAM. Storage is quasi permanent, limited only by the on-board battery (usually several years) . Unlike storage in Flash using the EE configuration commands, there are no limits in the amount or frequency of read and write cycles with BEE. This feature is only available on selected models, see product data-sheet. Battery must be installed in the controller for storage to be possible.

Syntax Serial: ^BEE aa dd
 ~BEE aa

Syntax Scripting: setconfig(_BEE, aa, dd)

Number of Arguments: 2

Argument 1: Address

Min: 1
 Max: Total Number of BEE

Argument 2: Value

Type: Signed 16-bit
 Min: -32768
 Default: 0
 Max: 32767

Where:

aa = Address

dd = Data

Example:

^BEE 1 555 : Store value 555 in Battery Backed RAM location 1

~BEE 1: Read data from RAM location 1

BRUN - MicroBasic Auto Start

HexCode: 48

Description:

This parameter is used to enable or disable the automatic MicroBasic script execution when the controller powers up. When enabled, the controller checks that a valid script is present in Flash and will start its execution 2 seconds after the controller has become active. The 2 seconds wait time can be circumvented by putting 2 in the command argument. However, this must be done only on scripts that are known to be bug-free. A crashing script will cause the controller to continuously reboot with little means to recover.

Syntax Serial: ^BRUN nn
~BRUN

Syntax Scripting: setconfig(_BRUN, nn)

Number of Arguments: 1

Argument 1: Enable

Type: Unsigned 8-bit

Min: 0

Max: 2

Default: 0 = Disabled

Where:

nn =

0: Disabled

1: Enabled after 2 seconds

2: Enabled immediately

CLIN - Command Linearity

HexCode: 0D

Description:

This parameter is used for applying an exponential or a logarithmic transformation on the command input, regardless of its source (serial, pulse or analog). There are 3 exponential and 3 logarithmic choices. Exponential correction make the commands change less at the beginning and become stronger at the end of the command input range. The logarithmic correction will have a stronger effect near the start and lesser effect near the end. The linear selection causes no change to the input. A linearity transform is also available for all analog and pulse inputs. Both can be enabled although in most cases, it is best to use the Command Linearity parameter for modifying command profiles

Syntax Serial: ^CLIN cc nn
 ~CLIN [cc]

Syntax Scripting: setconfig(_CLIN, cc, nn)

Number of Arguments: 2

Argument 1: Channel

Min: 1 Max: Total Number of Motors

Argument 2: Linearity

Type: Unsigned 8-bit
 Min: 0 Max: 7
 Default: 0 = Linear

Where:

- cc = Motor channel
- nn =
- 0: Linear (no change)
- 1: Exp weak
- 2: Exp medium
- 3: Exp strong
- 4: Log weak
- 5: Log medium
- 6: Log strong

Example:

^CLIN 1 1 : Sets linearity for channel 1 to exponential weak

CPRI - Command Priorities

HexCode: 07

Description:

This parameter contains up to 3 variables (4 on controllers with Spektrum radio support) and is used to set which type of command the controller will respond in priority and in which order. The first item is the third priority, the second item is the fourth priority, and the third item is the fifth priority. The first priority belongs to the script mode and the second priority belongs to the CAN mode. Each priority item is then one of the three (four) command modes: Serial, Analog (Spektrum) or RC Pulse. See Command Priorities in the User Manual. Default priority orders are: 1-Serial, 2-Pulse, 3-None.

Syntax Serial: ^CPRI pp nn
 ~CPRI [pp]

Syntax Scripting: setconfig(_CPRI, pp, nn)

Number of Arguments: 2

Argument 1: Level

Min: 1 Max: 3 or 4
 Default: See description

Example:

^DFC 1 500 : Sets motor command to 500 when no command source are detected

^DFC 2 1001 : Motor takes present position as destination after power up. Motor doesn't move.

DMOD – Modbus Mode

HexCode: A1

Description:

Configure this parameter in order to enable Modbus and the desired mode.

Syntax Serial: ^DMOD nn

~DMOD

Syntax Scripting: setconfig(_DMOD, nn)

Number of Arguments: 1

Argument 1: Modbus Mode

Type: Unsigned 8-bit

Min: 0 Max: 4

Default: 0

Where:

nn =

0: Off

1: TCP

2: RTU over TCP

3: RS232 ASCII

4: RS485 ASCII

Example:

^DMOD 3: Enable Modbus RS232 ASCII mode.

ECHOF - Enable/Disable Serial Echo

HexCode: 09

Description:

This command is used to disable/enable the echo on the RS232, RS485, TCP or USB port. By default, the controller will echo everything that enters the serial communication port. By setting ECHOF to 1, commands are no longer being echoed. The controller will only reply to queries and the acknowledgements to commands can be seen.

Syntax Serial: ^ECHOF nn

~ECHOF

Syntax Scripting: setconfig(_ECHOF, nn)

Number of Arguments: 1

Argument 1: OffOn

Type: Unsigned 8-bit
 Min: 0 Max: 1
 Default: 0 = Echo on

Where:

nn =
 0: Echo is enabled
 1: Echo is disabled

Example:

^ECHOF 1 : Disable echo

EE - Store User Data in Flash

HexCode: 00

Description:

Read and write user-defined values that can be permanently stored in Flash. Storage area size is typically 32 x 16-bit words but can vary from one product to the other. The command alters data contained in a RAM area. The %EESAV Maintenance Command, or !EES Real Time Command must be used to copy the RAM array to Flash. The Flash is copied to RAM every time the device powers up.

Syntax Serial: ^EE aa dd
 ~EE aa

Syntax Scripting: setconfig(_EE, aa, dd)

Number of Arguments: 2

Argument 1: Address

Min: 1 Max: Total Number of Storage words

Argument 2: Data

Type: Signed 16-bit
 Min: -32768 Max: +32767
 Default: 0

Where:

aa = Address
 dd = Data

Example:

^EE 1 555 : Store value 555 in RAM location 1
 %EESAV or !EES : Copy data from temporary RAM to Flash
 ~EE 1 : Read data from RAM location 1

Note:

See product datasheet to know the total available EE storage.
 Do not transfer to Flash with %EESAV or !EES at high frequency as the number of write cycles to Flash are limited to around 10000.
 Avoid transferring to Flash while the product is performing critical operation
 Write to address locations 1 and up. Writing at address 0 will fill all RAM location with the value

MDAL – Modbus Data Alignment

HexCode: CA

Description:

Configure this parameter in order to set the alignment of the Modbus byte frame. This option depends on what the Modbus master supports.

Syntax Serial: ^MDAL nn
~MDAL

Syntax Scripting: setconfig(_MDAL, nn)

Number of Arguments: 1

Argument 1: Modbus Data Alignment
Type: Unsigned 8-bit
Min: 0 Max: 3
Default: 0

Where:

nn =
0: High Word/High Byte
1: High Word/Low Byte
2: Low Word/High Byte
3: Low Word/Low Byte

Example:

^MDAL 2: Configure Modbus Data Alignment to Low Word/High Byte.

MNOD – Modbus Node ID

HexCode: A2

Description:

Configure this parameter in order to set Modbus Slave Node ID of the controller. In that way this controller will be distinguished inside a Modbus network.

Syntax Serial: ^MNOD nn
~MNOD

Syntax Scripting: setconfig(_MNOD, nn)

Number of Arguments: 1

Argument 1: Modbus Node ID
Type: Unsigned 8-bit
Min: 0 Max: 127
Default: 1

Where:

nn = Node ID

Example:

^MNOD 3: Configure Modbus Node ID to 3.

RSBR - Set RS232 bit rate

HexCode: 0A

Description:

Sets the serial communication bit rate of the RS232 and RS485 ports. Choices are one of five most common bit rates. On selected products, the port output can be inverted to allow a simplified connection to devices that have TTL serial ports instead of full RS232 (not applicable for RS485 port).

Syntax Serial: ^RSBR nn
 ~RSBR

Syntax Scripting: setconfig(_RSBR, nn)

Number of Arguments: 1

Argument 1: BitRate

 Type: Unsigned 8-bit

 Min: 0 Max: 4 or 9

 Default: 0 = 115200

Where:

nn =

0: 115200

1: 57600

2: 38400

3: 19200

4: 9600

5: 115200 + Inverted RS232

6: 57600 + Inverted RS232

7: 38400 + Inverted RS232

8: 19200 + Inverted RS232

9: 9600 + Inverted RS232

Example:

^RSBR 3 : sets baud rate at 19200

Note:

This configuration can only be changed while connected via USB or via scripting. After the baud rate has been changed, it will not be possible to communicate with the Roborun PC utility using the serial port until the rate is changed back to 115200. Slow bit rates may result in data loss if more characters are sent than can be handled. The inverted mode is only available on selected products.

RS485 - Enable RS485

HexCode: D0

Description:

Configure this parameter in order to enable the RS485 communication. This feature is applicable only on motor controllers, where RS485 pins are shared with other features. In these controllers the default value is Disabled. In any other controller that support RS485 with dedicated pins the default value is Enabled.

Syntax Serial: ^RS485 nn
 ~ RS485

Syntax Scripting: setconfig(_RS485, nn)

Number of Arguments: 1

Argument 1: Enable RS485

Type: Unsigned 8-bit

Min: 0 Max: 1

Default: 0

Where:

nn = Enable RS485

0: Disabled.

1: Enabled.

Example:

^RS485 1: Enable RS485.

RWD - Serial Data Watchdog

HexCode: 08

Description:

This is the Serial Commands watchdog timeout parameter. It is used to detect when the controller is no longer receiving commands and switch to the next priority level. Any Real-time Command arriving from RS232, RS485, TCP, USB, CAN or Microbasic Scripting, The watchdog value is a number in ms (1000 = 1s). The watchdog function can be disabled by setting this value to 0. The watchdog will only detect the loss of real time commands, as shown in section 6. All other traffic on the serial port will not refresh the watchdog timer. As soon as a valid command is received, motor operation will resume.

Syntax Serial: ^RWD nn
 ~RWD

Syntax Scripting: setconfig(_RWD, nn)

Number of Arguments: 1

Argument 1: Timeout

Type: Unsigned 16-bit

Min: 0

Max: 65000

Default: 1000 = 1s

Where:

nn = Timeout value in ms

Example:

^RWD 2000 : Set watchdog to 2s

^RWD 0 : Disable watchdog

SCRO - Select Print output port for scripting

HexCode: 5E

Description:

Selects which port the print statement sends data to. When 0, the last port which received a valid character will be the one the script outputs to.

Syntax Serial: ^SRO nn
 ~SCRO

Syntax Scripting: setconfig(_SRO, nn)

Number of Arguments: 1

Argument 1: Port

Type: Unsigned 8-bit

Min: 0

Max: 4

Default: 0 = Last used

Where:

nn =

0: Last used

1: Serial

2: USB

3: RS485 if applicable,

4: TCP if applicable

SKCTR - Spektrum Center

HexCode: 53

Description:

Value captured from Spektrum radio that will be considered as 0 command

Syntax Serial: ^SKCTR cc nn
 ~SKCTR [cc]

Syntax Scripting: setconfig(_SKCTR, cc)

Number of Arguments:

Argument 1: Channel

Min: 1

Max: 2

Argument 2: Center

Type: Unsigned 16-bit
 Min: 0
 Default: 0
 Max: 1024

Where:

cc = Channel
 nn = Center value

SKDB - Spektrum Deadband

HexCode: 54

Description:

Sets the deadband value for the Spektrum channel. It is defined as the percent number from 0 to 50% and defines the amount of movement from joystick or sensor around the center position before its converted value begins to change.

Syntax Serial: ^SKDB cc nn
 ~SKDB [cc]

Syntax Scripting: setconfig(_SKDB, cc)

Number of Arguments:

Argument 1: Channel

Min: 1
 Max: 2

Argument 2: Deadband

Type: Unsigned 8-bit
 Min: 0
 Default: 0
 Max: 50

Where:

cc = Channel
 nn = Deadband

SKLIN - Spektrum Linearity

HexCode: 55

Description:

This parameter is used for applying an exponential or a logarithmic transformation a Spektrum command input. There are 3 exponential and 3 logarithmic choices. Exponential correction will make the commands change less at the beginning and become stronger at the end of the joystick movement. The logarithmic correction will have a stronger effect near the start and lesser effect near the end. The linear selection causes no change to the input.

Syntax Serial: ^SKLIN cc nn
 ~SKLIN [cc]

Syntax Scripting: setconfig(_SKLIN, cc)

Number of Arguments:

Argument 1: Channel

Min: 1

Max: 2

Argument 2: Linearity

Type: Unsigned 8-bit

Min: 0

Max: 6

Default: 0 = Linear

Where:

cc = Input channel number

nn =

0 : linear (no change)

1: exp weak

2: exp medium

3: exp strong

4: log weak

5: log medium

6: log strong

SKMAX - Spektrum Max

HexCode: 52

Description:

Value captured from Spektrum radio that will be considered as +1000 command

Syntax Serial: ^SKMAX cc nn
~SKMAX [cc]

Syntax Scripting: setconfig(_SKMAX, cc)

Number of Arguments:

Argument 1: Channel

Min: 1

Max: 2

Argument 2: Max

Type: Unsigned 16-bit

Min: 0

Max: 1024

Default: 0

Where:

cc = Channel

nn = Max value

SKMIN - Spektrum Min

HexCode: 51

Description:

Value captured from Spektrum radio that will be considered as -1000 command

Syntax Serial: ^SKMIN cc nn
~SKMIN [cc]

Syntax Scripting: setconfig(_SKMIN, cc)

Number of Arguments:

Argument 1: Channel

Min: 1

Max: 2

Argument 2: Min

Type: Unsigned 16-bit

Min: 0

Max: 1024

Default: 0

Where:

cc = Channel

nn: Min value

SKUSE - Assign Spektrum port to motor command

HexCode: 50

Description:

Chose which of the 6 joysticks from the Spektrum RC receiver is to be assigned to which motor command channel.

Syntax Serial: ^SKUSE cc nn
~SKUSE [cc]

Syntax Scripting: setconfig(_SKUSE, cc)

Number of Arguments:

Argument 1: Channel

Min: 1

Max: 2

Argument 2: Port

Type: Unsigned 8-bit

Min: 1

Max: 6

Where:

cc = Channel number

nn = Radio port

STO – STO Enable

HexCode: CF

Description:

Configure this parameter in order to enable the STO functionality. For boards which have the respective circuit the respective jumper needs to be removed (see Chapter **Safe Torque-Off (STO)**, in Section2).

Syntax Serial: ^STO nn
 ~STO

Syntax Scripting: setconfig(_STO, nn)

Number of Arguments: 1

Argument 1: STO Status

Type: Unsigned 8-bit

Min: 0 Max: 1

Default: 0

Where:

nn = STO status

0: Disabled.

1: Enabled.

Example:

^STO 1: Enable STO functionality.

TELS - Telemetry String

HexCode: 47

Description:

This parameter command lets you enter the telemetry string that will be used when the controller starts up. The string is entered as a series of queries characters between a beginning and an ending quote. Queries must be separated by ":" colon characters. Upon the power up, the controller will load the query history buffer and it will automatically start executing commands and queries based on the information in this string. Strings up to 48 characters long can be stored in this parameter.

Syntax Serial: ^TELS "string"
 ~TELS

Syntax Scripting:

Number of Arguments: 1

Argument 1: Telemetry

Type: String
 Min: "" Max: 48 characters string
 Default: "" = Empty string

Where:

string = string of ASCII characters between quotes

Example:

^TELS "?A:?V:?T:# 200" = Controller will issue Amps, Volts and temperature information automatically upon power up at 200ms intervals.

Analog, Digital, Pulse IO Configurations

These parameters configure the operating mode and how the inputs and outputs work.

TABLE 15-21. Input/Output Configurations

Command	Arguments	Description
ACTR	InputNbr Center	Set Analog Input Center (0) Level
ADB	InputNbr Deadband	Analog Deadband
AINA	InputNbr Use	Analog Input Use
ALIN	InputNbr Linearity	Analog Linearity
AMAX	InputNbr Max	Set Analog Input Max Range
AMAXA	InputNbr Action	Action at Analog Max
AMIN	InputNbr Min	Set Analog Input Min Range
AMINA	InputNbr Action	Action at Analog Min
AMOD	InputNbr Mode	Enable and Set Analog Input Mode
APOL	InputNbr Polarity	Analog Input Polarity
DINA	InputNbr Action	Digital Input Action
DINL	ActiveLevels	Digital Input Active Level
DOA	OutputNbr Action	Digital Output Action
DOL	ActiveLevels	Digital Outputs Active Level
PCTR	InputNbr Center	Pulse Center Range
PDB	InputNbr Deadband	Pulse Input Deadband
PINA	InputNbr Use	Pulse Input Use
PLIN	InputNbr Linearity	Pulse Linearity
PMAX	InputNbr Max	Pulse Max Range
PMAXA	InputNbr Action	Action on Pulse Max
PMIN	InputNbr Min	Pulse Min Range
PMINA	InputNbr Action	Action on Pulse Min
PMOD	InputNbr Mode	Pulse Mode Select
PPOL	InputNbr Polarity	Pulse Input Polarity

ACTR - Set Analog Input Center (0) Level

HexCode: 16

Description:

This parameter is the measured voltage on input that will be considered as the center or the 0 value. The min, max and center are useful to set the range of a joystick or of a feedback sensor. Internally to the controller, commands and feedback values are converted to 1000, 0, +1000.

Syntax Serial: ^ACTR cc nn
~ACTR [cc]

Syntax Scripting: setconfig(_ACTR, cc, nn)

Number of Arguments: 2

Argument 1: InputNbr

Argument 2: Center	Min: 1	Max: Total Number of Analog Inputs
	Type: Unsigned 16-bit	
	Min: 0	Max: 10000
	Default: 2500 mV	

Where:

cc = Analog input channel

nn = 0 to 10000mV

Example:

^ACTR 3 2000 : Set Analog Input 3 Center to 2000mV

Note:

Center value must always be a number greater of equal to Min, and smaller or equal to Max

Make the center value the same as the min value in order to produce a converted output range that is positive only (0 to +1000)

ADB - Analog Deadband

HexCode: 17

Description:

This parameter selects the range of movement change near the center that should be considered as a 0 command. This value is a percentage from 0 to 50% and is useful to allow some movement of a joystick around its center position without change at the converted output

Syntax Serial: ^ADB cc nn
~ADB [cc]

Syntax Scripting: setconfig(_ADB, cc, nn)

Number of Arguments: 2

Argument 1: InputNbr
 Min: 1 Max: Total Number of Analog Inputs

Argument 2: Deadband
 Type: Unsigned 8-bit
 Min: 0 Max: 50
 Default: 5 = 5%

Where:

cc = Analog input channel
 nn = Deadband in %

Example:

^ADB 6 10 : Sets Deadband for channel 6 at 10%

Note:

Deadband is not used when input is used as feedback

AINA - Analog Input Use

HexCode: 19

Description:

This parameter selects whether an input should be used as a command feedback or left unused. When selecting command or feedback, it is also possible to select which channel this command or feedback should act on. Feedback can be position feedback if potentiometer is used or speed feedback if tachometer is used. Embedded in the parameter is the motor channel to which the command or feedback should apply.

Syntax Serial: ^AINA cc (nn + mm)
 ~AINA [cc]

Syntax Scripting: setconfig_LAINA, cc, nn)

Number of Arguments: 2

Argument 1: InputNbr
 Min: 1 Max: Total Number of Analog Inputs

Argument 2: Use
 Type: Unsigned 8-bit
 Min: 0 Max: 255
 Default: 0 = No action

Where:

cc = Analog input channel
 nn =
 0: No action
 1: Command

2: Feedback
 mm =
 $\text{mot1} * 16 + \text{mot2} * 32 + \text{mot3} * 48$

Example:

^AINA 1 17: Sets Analog channel 1 as command for motor 1. I.e. 17 = 1 (command) +16 (motor 1)

ALIN - Analog Linearity

HexCode: 18

Description:

This parameter is used for applying an exponential or a logarithmic transformation on an analog input. There are 3 exponential and 3 logarithmic choices. Exponential correction will make the commands change less at the beginning and become stronger at the end of the joystick movement. The logarithmic correction will have a stronger effect near the start and lesser effect near the end. The linear selection causes no change to the input.

Syntax Serial: ^ALIN cc nn
~ALIN [cc]

Syntax Scripting: setconfig(_ALIN, cc, nn)

Number of Arguments: 2

Argument 1: InputNbr

Min: 1

Max: Total Number of Analog Inputs

Argument 2: Linearity

Type: Unsigned 8-bit

Min: 0

Max: 6

Default: 0 = Linear

Where:

cc = Analog input channel

nn =

0: Linear (no change)

1: Exp weak

2: Exp medium

3: Exp strong

4: Log weak

5: Log medium

6: Log strong

Example:

^ALIN 1 1 : Sets linearity for channel 1 to exp weak

AMAX - Set Analog Input Max Range

HexCode: 15

Description:

This parameter sets the voltage that will be considered as the maximum command value. The min, max and center are useful to set the range of a joystick or of a feedback sensor. Internally to the controller, commands and feedback values are converted to -1000, 0, +1000.

Syntax Serial: ^AMAX cc nn
 ~AMAX [cc]

Syntax Scripting: setconfig(_AMAX, cc, nn)

Number of Arguments: 2

Argument 1: InputNbr
 Min: 1 Max: Total Number of Analog Inputs

Argument 2: Max
 Type: Unsigned 16-bit
 Min: 0 Max: 10000
 Default: 4900 mV

Where:

cc = Analog input channel
 nn = 0 to 10000mV

Example:

^AMAX 4 4500 : Set Analog Input 4 Max range to 4500mV

Note:

Analog input can capture voltage up to around 5.2V. Setting the Analog maximum above 5200 mV, means the conversion will never be able to reach +1000

AMAXA - Action at Analog Max

HexCode: 1B

Description:

This parameter selects what action should be taken if the maximum value that is defined in AMAX is reached. The list of action is the same as these of digital inputs. For example, this feature can be used to create soft limit switches, in which case the motor can be made to stop if the feedback sensor in a position mode has reached a maximum value.

Syntax Serial: ^AMAXA cc (aa + mm)
 ~AMAXA [cc]

Syntax Scripting: setconfig(_AMAXA, cc, aa)

Number of Arguments: 2

Argument 1: InputNbr
 Min: 1 Max: Total Number of Analog Inputs

Argument 2: Action
 Type: Unsigned 8-bit
 Min: 0 Max: 255
 Default: 0 = No action

Where:

cc = Analog input channel
 aa =
 0: No action
 1: Safety stop

- 2: Emergency stop
 - 3: Motor stop
 - 4: Forward limit switch
 - 5: Reverse limit switch
 - 6: Invert direction
 - 7: Run MicroBasic script
 - 8: Load counter with home value
- $mm = mot1 * 16 + mot2 * 32 + mot3 * 48$

Example:

`^AMAXA 3 33` : Stops motor 2. I.e. $33 = 1$ (safety stop) + 32 (motor2)

AMIN - Set Analog Input Min Range

HexCode: 14

Description:

This parameter sets the raw value on the input that will be considered as the minimum command value. The min, max and center are useful to set the range of a joystick or of a feedback sensor. Internally to the controller, commands and feedback values are converted to -1000, 0, +1000.

Syntax Serial: `^AMIN cc nn`
`~AMIN [cc]`

Syntax Scripting: `setconfig(_AMIN, cc, nn)`

Number of Arguments: 2

Argument 1: InputNbr

Min: 1

Max: Total Number of Analog Inputs

Argument 2: Min

Type: Unsigned 16-bit

Min: 0

Max: 10000

Default: 100 mV

Where:

cc = Analog input channel

nn = 0 to 10000mV

Example:

`^AMIN 5 250` : Set Analog Input 5 Min to 250mV

Note:

Analog input can capture voltage up to around 5.2V. Setting the Analog minimum between 5200 and 10000 mV means the conversion will always return 0

AMINA - Action at Analog Min

HexCode: 1A

Description:

This parameter selects what action should be taken if the minimum value that is defined in AMIN is reached. The list of action is the same as these of the DINA configuration com-

mand. For example, this feature can be used to create soft limit switches, in which case the motor can be made to stop if the feedback sensor in a position mode has reached a minimum value.

Syntax Serial: ^AMINA cc (aa + mm)
 ~AMINA [cc]

Syntax Scripting: setconfig(_AMINA, cc, aa)

Number of Arguments: 2

Argument 1: InputNbr

Min: 1 Max: Total Number of Analog Inputs

Argument 2: Action

Type: Unsigned 8-bit
 Min: 0 Max: 255
 Default: 0 = No action

Where:

- cc = Analog input channel
- aa =
- 0: No action
- 1: Safety stop
- 2: Emergency stop
- 3: Motor stop
- 4: Forward limit switch
- 5: Reverse limit switch
- 6: Invert direction
- 7: Run MicroBasic script
- 8: Load counter with home value
- mm = mot1*16 + mot2*32 + mot3*48

Example:

^AMINA 2 33 : Stops motor 2. I.e. 33 = 1 (safety stop) + 32 (motor2)

AMOD - Enable and Set Analog Input Mode

HexCode: 13

Description:

This parameter is used to enable/disable an analog input pin. When enabled, it can be made to measure an absolute voltage from 0 to 5V, or a relative voltage that takes the 5V output on the connector as the 5V reference. The absolute mode is preferred whenever measuring a voltage generated by an outside device or sensor. The relative mode is the mode to use when a sensor or a potentiometer is powered using the controller's 5V output of the controller. Using the relative mode gives a correct sensor reading even though the 5V output is imprecise.

Syntax Serial: ^AMOD cc nn
 ~AMOD [cc]

Syntax Scripting: setconfig(_AMOD, cc, nn)

Number of Arguments: 2

Argument 1: InputNbr

Min: 1 Max: Total Number of Analog Inputs

Argument 2: Mode

Type: Unsigned 8-bit

Min: 0

Max: 2

Default: 0 = Disabled

Where:

cc = Analog input channel

nn =

0: Disabled

1: Absolute

2: Relative

Example:

^AMOD 1 1 : Analog input 1 enabled in absolute mode

APOL - Analog Input Polarity

HexCode: 1C

Description:

Inverts the analog capture polarity value after conversion. When this configuration bit is cleared, the pulse capture is converted into a -1000 to +1000 command or feedback value. When set, the converted range is inverted to +1000 to -1000.

Syntax Serial: ^APOL cc nn
~APOL [cc]

Syntax Scripting: setconfig(_APOL, cc, nn)

Number of Arguments: 2

Argument 1: InputNbr

Min: 1 Max: Total Number of Analog Inputs

Argument 2: Polarity

Type: Unsigned 8-bit

Min: 0

Max: 1

Default: 0 = Non inverted

Where:

cc = Analog input channel

nn =

0: Not inverted

1: Inverted

DINA - Digital Input Action

HexCode: 0F

Description:

This parameter sets the action that is triggered when a given input pin is activated. The action list includes: limit switch for a selectable motor and direction, use as a deadman switch, emergency stop, safety stop or invert direction. Embedded in the parameter is the motor channel(s) to which the action should apply.

Syntax Serial: ^DINA cc (aa + [mm])
~DINA [cc]

Syntax Scripting: setconfig(_DINA, cc, aa)

Number of Arguments: 2

Argument 1: InputNbr

Min: 0 Max: Total Number of Digital Inputs

Argument 2: Action

Type: Unsigned 8-bit

Min: 0

Max: 255

Default: 0 = No actions

Where:

cc = Input channel number

aa =

0: No action

1: Safety stop

2: Emergency stop

3: Motor stop

4: Forward limit switch

5: Reverse limit switch

6: Invert direction

7: Run MicroBasic script

8: Load counter with home value

mm = mot1*16 + mot2*32 + mot3*48

Example:

^DINA 1 33 : Input 1 as safety stop for Motor 1. I.e. 33 = 1 (safety stop) + 32 (Motor1)

DINL - Digital Input Active Level

HexCode: 10

Description:

This parameter is used to set the active level for each Digital input. An input can be made to be active high or active low. Active high means that pulling it to a voltage will trigger an action. Active low means pulling it to ground will trigger an action. This parameter is a single number for all inputs.

2: Motor reversed
3: Overvoltage
4: Overtemperature
5: Mirror status LED
6: No MOSFET failure

Example:

`^DOA 1 3` : Output 1 is active when Overvoltage is observed

Note:

Typical default configuration is Digital outputs 1 (2) are active when motor is on. Digital output 2 (3) when no MOSFET failure is detected.

To activate an output via serial command or from a Microbasic script, set that output to Never

DOL - Digital Outputs Active Level

HexCode: 12

Description:

This parameter configures whether an output should be set to ON or to OFF when it is activated.

Syntax Serial: `^DOL cc aa`
`~DOL`

Syntax Scripting: `setconfig(_DOL, cc, aa)`

Number of Arguments: 1

Argument 1: ActiveLevels

Type: Unsigned 32-bit

Min: 0

Max: 2 ^ Total Number of Digital Outputs

Default: 0 = All active high

Where:

cc = Digital input number

aa=

0: On when active

1: Off when active

PCTR - Pulse Center Range

HexCode: 20

Description:

This defines the raw value of the measured pulse that would be considered as the 0 value inside the controller. The default value is 1500 which is the center position of the pulse in the RC radio mode.

Syntax Serial: `^PCTR cc nn`
`~PCTR [cc]`

Syntax Scripting: setconfig(_PCTR, cc, nn)

Number of Arguments: 2

Argument 1: InputNbr

Min: 1 Max: Total Number of Pulse Inputs

Argument 2: Center

Type: Unsigned 16-bit

Min: 0

Max: 65536

Default: 1500us

Where:

cc = Pulse input number

nn = 0 to 65536us

PDB - Pulse Input Deadband

HexCode: 21

Description:

This sets the deadband value for the pulse capture. It is defined as the percent number from 0 to 50% and defines the amount of movement from joystick or sensor around the center position before its converted value begins to change.

Syntax Serial: ^PDB cc nn

~PDB [cc]

Syntax Scripting: setconfig(_PDB, cc, nn)

Number of Arguments: 2

Argument 1: InputNbr

Min: 1 Max: Total Number of Pulse Inputs

Argument 2: Deadband

Type: Unsigned 8-bit

Min: 0

Max: 50

Default: 5 = 5%

Where:

cc = Pulse input number

nn = Deadband in %

Note:

Deadband is not used when input is used as feedback

PINA - Pulse Input Use

HexCode: 23

Description:

This parameter selects whether an input should be used as a command feedback, position feedback or left unused. Embedded in the parameter is the motor channel that this command or feedback should act on. Feedback can be position feedback if potentiometer is used or speed feedback if tachometer is used.

Syntax Serial: ^PINA cc (nn + mm)
 ~PINA [cc]

Syntax Scripting: setconfig(_PINA, cc, nn)

Number of Arguments: 2

Argument 1: InputNbr

Min: 1 Max: Total Number of Pulse Inputs

Argument 2: Use

Type: Unsigned 8-bit
 Min: 0 Max: 255
 Default: See note

Where:

cc = Pulse input number
 nn =
 0: No action
 1: Command
 2: Feedback
 mm =
 $\text{mot1} * 16 + \text{mot2} * 32 + \text{mot3} * 48$

Example:

^A1NA 1 17: Sets Pulse input 1 as command for motor 1. I.e. 17 = 1 (command) + 16 (motor 1)

PLIN - Pulse Linearity

HexCode: 22

Description:

This parameter is used for applying an exponential or a logarithmic transformation on a pulse input. There are 3 exponential and 3 logarithmic choices. Exponential correction will make the commands change less at the beginning and become stronger at the end of the joystick movement. The logarithmic correction will have a stronger effect near the start and lesser effect near the end. The linear selection causes no change to the input.

Syntax Serial: ^PLIN cc nn
 ~PLIN [cc]

Syntax Scripting: setconfig(_PLIN, cc, nn)

Number of Arguments: 2

Argument 1: InputNbr

Min: 1 Max: Total Number of Pulse Inputs

Argument 2: Linearity

Type: Unsigned 8-bit
 Min: 0 Max: 6
 Default: 0 = Linear

Where:

cc = Pulse input number
nn =
0: Linear (no change)
1: Exp weak
2: Exp medium
3: Exp strong
4: Log weak
5: Log medium
6: Log strong

PMAX - Pulse Max Range

HexCode: 1F

Description:

This parameter defines the raw pulse measurement number that would be considered as the +1000 internal value to the controller. By default, it is set to 2000 which is the max pulse width of an RC radio pulse.

Syntax Serial: ^PMAX cc nn
~PMAX [cc]

Syntax Scripting: setconfig(_PMAX, cc, nn)

Number of Arguments: 2

Argument 1: InputNbr
Min: 1 Max: Total Number of Pulse Inputs

Argument 2: Max
Type: Unsigned 16-bit
Min: 0 Max: 65536
Default: 2000

Where:

cc = Pulse input number
nn = 0 to 65536us

PMAXA - Action on Pulse Max

HexCode: 25

Description:

This parameter configures the action to take when the max value that is defined in PMAX is reached. The list of action is the same as in the DINA digital input action list. Embedded in the parameter is the motor channel(s) to which the action should apply.

Syntax Serial: ^PMAXA cc (aa + mm)
~PMAXA [cc]

Syntax Scripting: setconfig(_PMAXA, cc, aa)

Number of Arguments: 2

Argument 1: InputNbr

Min: 1 Max: Total Number of Pulse Inputs

Argument 2: Action

Type: Unsigned 8-bit
 Min: 0 Max: 255
 Default: 0 = No action

Where:

- cc = Pulse input number
- aa =
- 0: No action
- 1: Safety stop
- 2: Emergency stop
- 3: Motor stop
- 4: Forward limit switch
- 5: Reverse limit switch
- 6: Invert direction
- 7: Run MicroBasic script
- 8: Load counter with home value

$$mm = mot1*16 + mot2*32 + mot3*48$$

PMIN - Pulse Min Range

HexCode: 1E

Description:

This sets the raw value of the pulse capture that would be considered as the -1000 internal value to the controller. The value is in number of microseconds (1000 = 1ms). The default value is 1000 microseconds which is the typical minimum value on an RC radio pulse.

Syntax Serial: ^PMIN cc nn
 ~PMIN [cc]

Syntax Scripting: setconfig(_PMIN, cc, nn)

Number of Arguments: 2

Argument 1: InputNbr

Min: 1 Max: Total Number of Pulse Inputs

Argument 2: Min

Type: Unsigned 16-bit
 Min: 0 Max: 65536
 Default: 1000

Where:

- cc = Pulse input number
- nn = 0 to 65536us

PMINA - Action on Pulse Min

HexCode: 24

Description:

This parameter selects what action should be taken if the minimum value that is defined in PMIN is reached. The list of action is the same as these of the DINA digital input actions. Embedded in the parameter is the motor channel(s) to which the action should apply.

Syntax Serial: ^PMINA cc (aa + mm)
~PMINA [cc]

Syntax Scripting: setconfig(_PMINA, cc, aa)

Number of Arguments: 2

Argument 1: InputNbr

Min: 1 Max: Total Number of Pulse Inputs

Argument 2: Action

Type: Unsigned 8-bit

Min: 0

Max: 255

Default: 0 = No action

Where:

cc = Pulse input number

aa =

0: No action

1: Safety stop

2: Emergency stop

3: Motor stop

4: Forward limit switch

5: Reverse limit switch

6: Invert direction

7: Run MicroBasic script

8: Load counter with home value

mm = mot1*16 + mot2*32 + mot3*48

PMOD - Pulse Mode Select

HexCode: 1D

Description:

This parameter is used to enable/disable the pulse input and select its operating mode, which can be: pulse with measurement, frequency or duty cycle. Inputs can be measured with a high precision over a large range of time or frequency. An input will be processed and converted to a command or a feedback value in the range of -1000 to +1000 for use by the controller internally.

Syntax Serial: ^PMOD cc nn
~PMOD [cc]

Syntax Scripting: setconfig(_PMOD, cc, nn)

Number of Arguments: 2

Argument 1: InputNbr

Min: 1 Max: Total Number of Pulse Inputs

Argument 2: Mode

Type: Unsigned 8-bit

Min: 0

Max: 4

Default: See note

Where:

cc = Pulse input number

nn =

0: Disabled

1: Pulse width

2: Frequency

3: Duty cycle

4: Magsensor

5: BMS

6: Pulse Count

7: Flow Sensor

Example:

^PMOD 4 4 : Sets Pulse input 4 in Multi-PWM for Robteq's MGS1600 magnetic guide sensor

Note:

Pulse width is designed for capturing RC radio commands. Pulse width must be between 500us and 3000us, and repeat rate 50Hz or higher

On some products, enabling a pulse input will cause an offset voltage to be present when that same input is read as analog

PPOL - Pulse Input Polarity

HexCode: 26

Description:

Inverts the pulse capture value after conversion. When this configuration bit is cleared, the pulse capture is converted into a -1000 to +1000 command or feedback value. When set, the converted range is inverted to +1000 to -1000. Center value must always be a number greater or equal to Min, and smaller or equal to Max. Make the center value the same as the min value in order to produce a converted output range that is positive only (0 to +1000)

Syntax Serial: ^PPOL cc nn
~PPOL

Syntax Scripting: setconfig(_PPOL, cc, nn)

Number of Arguments: 2

Argument 1: InputNbr

Min: 1 Max: Total Number of Pulse Inputs

Argument 2: Polarity

Type: Unsigned 8-bit

Min: 0

Max: 1

Default: 0 = Non inverted

Where:

cc = Pulse input number

nn =

0: Not inverted

1: Inverted

Motor Configurations

This section covers the various configuration parameter applying to motor operations.

TABLE 15-22. Motor Configurations

Command	Arguments	Description
ALIM	Channel Limit	Amp Limit
ATGA	Channel Action	Amps Trigger Action
ATGD	Channel Delay	Amps Trigger Delay
ATRIG	Channel Level	Amps Trigger Level
BKD	Delay	Brake activation delay in ms
BLFB	Channel Sensor	Encoder or Hall Sensor Feedback for closed loop
BLSTD	Channel Mode	Stall Detection
CLERD	Channel Mode	Close Loop Error Detection
EDEC	Channel Deceleration	Fault Motor Deceleration Rate
EHL	Channel Value	Encoder High Count Limit
EHLA	Channel Action	Encoder High Limit Action
EHOME	Channel Value	Encoder Counter Load at Home Position
ELL	Channel Value	Encoder Low Count Limit
ELLA	Channel Action	Encoder Low Limit Action
EMOD	Channel Use	Encoder Usage
EPPR	Channel Value	Encoder PPR Value
ICAP	Channel Cap	PID Integral Cap
KD	Channel Gain	PID Differential Gain
KI	Channel Gain	PID Integral Gain
KP	Channel Gain	PID Proportional Gain
MAC	Channel Acceleration	Motor Acceleration Rate
MDEC	Channel Deceleration	Motor Deceleration Rate
MLX	InputNbr Value	Molex Input
MMOD	Channel Mode	Operating Mode

Command	Arguments	Description
MVEL	Channel Velocity	Default Position Velocity
MXMD	Mode	Separate or Mixed Mode Select
MXPF	Channel MaxPower	Motor Max Power Forward
MXPR	Channel MaxPower	Motor Max Power Reverse
MXRPM	Channel RPM	Max RPM Value
MXTRN	Channel Turns	Number of turns between limits
OVH	Voltage	Overvoltage hysteresis
OVL	Voltage	Overvoltage Cutoff Limit
OTL	Temperature	Over Temperature Cutoff Limit
PWMF	Frequency	PWM Frequency
SCPR	Channel Value	SSI Sensor CPR Value
SHL	Channel Value	SSI Sensor High Count Limit
SHLA	Channel Action	SSI Sensor High Limit Action
SHOME	Channel Value	SSI Sensor Counter Load at Home Position
SLL	Channel Value	SSI Sensor Low Count Limit
SLLA	Channel Action	SSI Sensor Low Limit Action
SMOD	Channel Use	SSI SEnsor Usage
THLD	Threshold	Short Circuit Detection Threshold
TNM	Channel Constant	Motor Torque Constant
UVL	Voltage	Undervoltage Limit

ALIM - Amp Limit

HexCode: 2A

Description:

This is the maximum Amps that the controller will be allowed to deliver to a motor regardless the load of that motor. The value is entered in Amps multiplied by 10. The value is the Amps that are measured at the motor and not the Amps measured from a battery. When the motor draws current that is above that limit, the controller will automatically reduce the output power until the current drops below that limit. For brushless controllers this value is considered to be in RMS.

Syntax Serial: ^ALIM cc nn
 ~ALIM [cc]

Syntax Scripting: setconfig(_ALIM, cc, nn)

Number of Arguments: 2

Argument 1: Channel

Min: 1 Max: Total Number of Motors

Argument 2: Limit

Type: Unsigned 16-bit
 Min: 10 Max: Max Amps in datasheet
 Default: See note

Where:

cc = Motor channel
nn = Amps *10

Example:

^ALIM1 455: Set Amp limit for Motor 1 to 45.5A

Note:

Default value is typically set to 75% of the controller's max amps as defined in the data-sheet

ATGA - Amps Trigger Action

HexCode: 2C

Description:

This parameter sets what action to take when the Amps trigger is activated. The list is the same as in the DINA digital input actions. Typical use for that feature is as a limit switch when, for example, a motor reaches an end and enters stall condition, the current will rise, and that current increase can be detected and the motor be made to stop until the direction is reversed. Embedded in the parameter is the motor channel(s) to which the action should apply.

Syntax Serial: ^ATGA cc (aa + mm)
~ATGA [cc]

Syntax Scripting: setconfig(_ATGA, cc, aa)

Number of Arguments: 2

Argument 1: Channel

Min: 1

Max: Total Number of Motors

Argument 2: Action

Type: Unsigned 8-bit

Min: 10

Max: 255

Default: 0 = No action

Where:

cc = Motor channel

aa =

0 : No action

1: Safety stop

2: Emergency stop

3: Motor stop

4: Forward limit switch

5: Reverse limit switch

6: Invert direction

7: Run MicroBasic script

8: Load counter with home value

mm = mot1*16 + mot2*32 + mot3*48

ATGD - Amps Trigger Delay

HexCode: 2D

Description:

This parameter contains the time in milliseconds during which the Amps Trigger Level (ATRIG) must be exceeded before the Amps Trigger Action (ATGA) is called. This parameter is used to prevent Amps Trigger Actions to be taken in case of short duration spikes.

Syntax Serial: ^ATGD cc nn
 ~ATGD [cc]

Syntax Scripting: setconfig(_ATGD, cc, nn)

Number of Arguments: 2

Argument 1: Channel	Min: 1	Max: Total Number of Motors
Argument 2: Delay	Type: Unsigned 16-bit Min: 0 Default: 500ms	Max: 10000

Where:

cc = Motor channel
 nn = Delay in ms

Example:

^ATGD 1 1000: Action will be triggered if motor Amps exceeds the value set with ATGL for more than 1000ms

ATRIG - Amps Trigger Level

HexCode: 2B

Description:

This parameter lets you select Amps threshold value that will trigger an action. This threshold must be set to be below the ALIM Amps limit. When that threshold is reached, then list of action can be selected using the ATGA parameter.

Syntax Serial: ^ATRIG cc nn
 ~ATRIG [cc]

Syntax Scripting: setconfig(_ATRIG, cc, nn)

Number of Arguments: 2

Argument 1: Channel	Min: 1	Max: Total Number of Motors
Argument 2: Level	Type: Unsigned 16-bit Min: 10 Default: Max Amps rating in datasheet	Max: Max Amps in datasheet

Where:

cc = Motor channel
nn = Amps *10

Example:

^ATRIG2 550: Set Amps Trigger to 55.0A

BKD - Brake activation delay in ms

HexCode: 0F

Description:

Set the delay in milliseconds from the time a motor stops and the time an output connected to a brake solenoid will be released. Applies to any Digital Output(s) that is configured as motor brake. Delay value applies to all motors in multi-channel products.

Syntax Serial: ^BKD nn
~BKD

Syntax Scripting: setconfig(_BKD, nn)

Number of Arguments: 1

Argument 1: Delay

Type: Unsigned 16-bit	
Min: 0	Max: 65536
Default: 250 = 250ms	

Where:

nn = Delay in milliseconds

Example:

^BKD 1 1000 : Causes the digital output to go off, and therefore activate the brake, 1.0s after motor stops being energized

BLFB - Encoder or Hall Sensor Feedback for closed loop

HexCode: 3B

Description:

This parameter is used to select which feedback sensor will be used to measure speed or position. On brushless motors system equipped with optical encoders and/or SSI sensors, this parameter lets you select either of these two sensors or the brushless sensors (ie. Hall, Sin/Cos, or Resolver), as the source of speed or position feedback. Encoders provide higher precision capture and should be preferred whenever possible. SSI sensors provide absolute feedback and are preferred in position modes (e.g. steering). The choice "Other" is also used to select pulse or analog feedback in some position modes.

Syntax Serial: ^BLFB cc nn
~BLFB

Syntax Scripting: `setconfig(_BLFB, cc, nn)`

Number of Arguments: 2

Argument 1: Channel

Min: 1

Max: Total Number of Motors

Argument 2: Sensor

Type: Unsigned 8-bit

Min: 0

Max: 1

Default: 0 = Other Sensor

Where:

cc = Motor channel

nn =

0: Other feedback (Encoders, SSI sensors, Analog or RC sensors)

1: Brushless sensor feedback (Hall, Sin/Cos, Resolver)

BLSTD - Stall Detection

HexCode: 3A

Description:

This parameter controls the stall detection of brushless motors and of brushed motors in closed loop speed mode. If no motion is sensed (i.e. counter remains unchanged) for a preset amount of time while the power applied is above a given threshold, a stall condition is detected and the power to the motor is cut until the command is returned to 0. This parameter allows three combinations of time & power sensitivities. The setting also applies when encoders are used in closed loop speed or closed loop speed position modes on brushed or brushless motors

Syntax Serial: `^BLSTD cc nn`

`~BLSTD [cc]`

Syntax Scripting: `setconfig(_BLSTD, cc, nn)`

Number of Arguments: 2

Argument 1: Channel

Min: 1

Max: Total Number of Motors

Argument 2: Mode

Type: Unsigned 8-bit

Min: 0

Max: 3

Default: 2 = 500ms at 25% Power

Where:

cc = Motor channel

nn =

0: Disabled

1: 250ms at 10% Power

2: 500ms at 25% Power

3: 1000ms at 50% Power

Example:

^BLSTD 2: Motor will stop if applied power is higher than 10% and no motion is detected for more than 250ms

CLERD - Close Loop Error Detection

HexCode: 38

Description:

This parameter is used to detect large tracking errors due to mechanical or sensor failures, and shut down the motor in case of problem in closed loop speed or position system. The detection mechanism looks for the size of the tracking error and the duration the error is present. This parameter allows three combinations of time & error level. This parameter is not compatible with Closed Loop Speed Position mode.

Syntax Serial: ^CLERD cc nn
~CLERS

Syntax Scripting: setconfig(_CLERD, cc, nn)

Number of Arguments: 2

Argument 1: Channel

	Min: 1	Max: Total Number of Motor
Channels		

Argument 2: Mode

Type: Unsigned 8-bit	
Min: 0	Max: 3
Default: 2 = 500ms at Error > 250	

Where:

cc = Motor channel
nn =
0: Detection disabled
1: 250ms at Error > 100
2: 500ms at Error > 250
3: 1000ms at Error > 500

Example:

^CLERD 2: Motor will stop if command - feedback is greater than 100 for more than 250ms

Note:

Disabling the loop error can lead to runaway or other dangerous conditions in case of sensor failure

EDEC - Fault Motor Deceleration Rate

HexCode: E9

Description:

Set the rate of speed change during deceleration for a motor channel, when a fault takes place. The faults under which this rate will be used are, Safety Stop, Deadman Switch and Closed Loop Error. Fault Deceleration value is in 0.1*RPM per second. When using controllers fitted with encoder, the speed and deceleration value are actual RPMs. Brushless motor controllers use the hall sensor for measuring actual speed and acceleration will also be in actual RPM/s.

Syntax Serial: ^EDEC cc nn ~EDEC [cc]

Syntax Scripting: setconfig(_EDEC, cc, nn)

Number of Arguments: 2

Argument 1: Channel Type: Unsigned 8-bit Min: 1 Max: Total Number of Motor Channels

Argument 2: Deceleration Type: Signed 32-bit

Min: 0 Max: 500000 Default: 10000 = 1000.0 RPM/s

Where:

cc = Motor channel

nn = Deceleration time in 0.1 RPM per second

EHL - Encoder High Count Limit

HexCode: 4C

Description:

Defines a maximum count value at which the controller will trigger an action when the counter goes above that number. This feature is useful for setting up virtual or soft limit switches. This value, together with the Low Count Limit, are also used in the position mode to determine the travel range when commanding the controller with a relative position command. In this case, the High Limit Count is the desired position when a command of 1000 is received.

Syntax Serial: ^EHL cc nn
~EHL [cc]

Syntax Scripting: setconfig(_EHL, cc, nn)

Number of Arguments: 2

Argument 1: Channel

Min: 1

Max: Total Number of Encoders

Argument 2: Value

Type: Signed 32-bit

Min: -2147M

Max: 2147M

Default: +20000

Where:

cc = Encoder channel
nn = Counter value

EHLA - Encoder High Limit Action

HexCode: 4E

Description:

This parameter lets you select what kind of action should be taken when the high limit count is reached on the encoder. The list of action is the same as in the DINA digital input action list Embedded in the parameter is the motor channel(s) to which the action should apply.

Syntax Serial: ^EHLA cc nn
 ~EHLA [cc]

Syntax Scripting: setconfig(_EHLA, cc, nn)

Number of Arguments: 2

Argument 1: Channel

Min: 1

Max: Total Number of Encoders

Argument 2: Action

Type: Unsigned 8-bit

Min: 0

Max: 255

Default: 0 = No action

Where:

cc = Encoder channel
aa =
0: No action
1: Safety stop
2: Emergency stop
3: Motor stop
4: Forward limit switch
5: Reverse limit switch
6: Invert direction
7: Run MicroBasic script
8: Load counter with home value

mm = mot1*16 + mot2*32 + mot3*48

EHOME - Encoder Counter Load at Home Position

HexCode: 4F

Description:

Contains a value that will be loaded in the selected encoder counter when a home switch is detected, or when a Home command is received from the serial/USB, or issued from a MicroBasic script.

Syntax Serial: ^EHOME cc nn
 ~EHOME [cc]

Syntax Scripting: setconfig(_EHOME, cc, nn)

Number of Arguments: 2

Argument 1: Channel

Min: 1

Max: Total Number of Encoders

Argument 2: Value

Type: Signed 32-bit
 Min: -2147M
 Default: 0

Max: 2147M

Where:

cc = Encoder channel
 nn = Counter value to be loaded

ELL - Encoder Low Count Limit

HexCode: 4B

Description:

Defines a minimum count value at which the controller will trigger an action when the counter dips below that number. This feature is useful for setting up virtual or soft limit switches. This value, together with the High Count Limit, are also used in the position mode to determine the travel range when commanding the controller with a relative position command. In this case, the Low Limit Count is the desired position when a command of -1000 is received.

Syntax Serial: ^ELL cc nn
 ~ELL [cc]

Syntax Scripting: setconfig(_ELL, cc, nn)

Number of Arguments: 2

Argument 1: Channel

Min: 1

Max: Total Number of Encoders

Argument 2: Value

Type: Signed 32-bit
 Min: -2147M
 Default: -20000

Max: 2147M

Where:

cc = Encoder channel
 nn = Counter value

Example:

^ELL 1 -100000 : Set encoder 1 low limit to minus 100000

ELLA - Encoder Low Limit Action

HexCode: 4D

Description:

This parameter lets you select what kind of action should be taken when the low limit count is reached on the encoder. The list of action is the same as in the DINA digital input action list Embedded in the parameter is the motor channel(s) to which the action should apply.

Syntax Serial: ^ELLA cc (aa + mm)
~ELLA [cc]

Syntax Scripting: setconfig(_ELLA, cc, aa)

Number of Arguments: 2

Argument 1: Channel

Min: 1

Max: Total Number of Encoders

Argument 2: Action

Type: Unsigned 8-bit

Min: 0

Max: 255

Default: 0 = No action

Where:

cc = Encoder channel

aa =

0: No action

1: Safety stop

2: Emergency stop

3: Motor stop

4: Forward limit switch

5: Reverse limit switch

6: Invert direction

7: Run MicroBasic script

8: Load counter with home value

mm = mot1*16 + mot2*32 + mot3*48

EMOD - Encoder Usage

HexCode: 49

Description:

This parameter defines what use the encoder is for. The encoder can be used to set command or to provide feedback (speed or position feedback). The use of encoder as feedback devices is the most common. Embedded in the parameter is the motor to which the encoder is associated.

Syntax Serial: ^EMOD cc (aa + mm)
~EMOD [cc]

Syntax Scripting: setconfig(_EMOD, cc, aa)

Number of Arguments: 2

Argument 1: Channel

Min: 1

Max: Total Number of Encoders

Argument 2: Use

Type: Unsigned 8-bit

Min: 0

Max: 255

Default: 0 = Unused

Where:

cc = Encoder channel

aa =

0: Unused

1: Command

2: Feedback

mm =

mot1*16 + mot2*32 + mot3*48

Example:

^EMOD 1 18 = Encoder used as feedback for channel 1

EPPR - Encoder PPR Value

HexCode: 4A

Description:

This parameter will set the pulse per revolution of the encoder that is attached to the controller. The PPR is the number of pulses that is issued by the encoder when making a full turn. For each pulse there will be 4 counts which means that the total number of a counter increments inside the controller will be 4x the PPR value. Make sure not to confuse the Pulse Per Revolution and the Count Per Revolution when setting up this parameter. Entering a negative number will invert the counter and the measured speed polarity

Syntax Serial: ^EPPR cc nn

~EPPR [cc]

Syntax Scripting: setconfig(_EPPR, cc, nn)

Number of Arguments: 2

Argument 1: Channel

Min: 1

Max: Total Number of Encoders

Argument 2: Value

Type: Signed 16-bit

Min: -32768

Max: 32767

Default: 100

Where:

cc = Encoder channel
nn = PPR value

Example:

^EPPR 2 200 : Sets PPR for encoder 2 to 200

ICAP - PID Integral Cap

HexCode: 32

Description:

This parameter is the integral cap as a percentage. This parameter will limit maximum level of the Integral factor in the PID. It is particularly useful in position systems with long travel movement, and where the integral factor would otherwise become very large because of the extended time the integral would allow to accumulate. This parameter can be used to dampen the effect of the integral parameter without reducing the gain. This parameter may adversely affect system performance in closed loop speed mode as the Integrator must be allowed to reach high values in order for good speed control.

Syntax Serial: ^ICAP cc nn
~ICAP [cc]

Syntax Scripting: setconfig(_ICAP, cc, nn)

Number of Arguments: 2

Argument 1: Channel

Min: 1

Max: Total Number of Motors

Argument 2: Cap

Type: Unsigned 8-bit

Min: 1

Max: 100

Default: 100%

Where:

cc = Motor channel
nn = Integral cap in %

KD - PID Differential Gain

HexCode: 30

Description:

Sets the PID's Differential Gain for that channel. The value is set as the gain multiplied by 10^6 . This gain is used in all closed loop modes. In Torque mode, on brushless controllers, the FOC's PID is used instead and this parameter is used for the speed limiting tuning.

Syntax Serial: ^KD cc nn
~KD [cc]

Syntax Scripting: setconfig(_KD, cc, nn)

Number of Arguments: 2

Argument 1: Channel

Min: 1

Max: Total Number of Motors

Argument 2:

Min: 0

Gain Type: Unsigned 32-bit

Max: 2,000,000,000

Default: 0

Where:

cc = Motor channel

nn = Differential Gain *1,000,000

Example:

^KD 1 1500000: Set motor channel 1 Differential Gain to 1.5.

Note:

Do not use default values. As a starting point, use P=2, I=0, D=0 in position modes (including Speed Position mode). Use P=0, I=1, D=0 in closed loop speed mode and in torque mode. Perform full tuning after that.

KI - PID Integral Gain

HexCode: 2F

Description:

Sets the PID's Integral Gain for that channel. The value is set as the gain multiplied by 10⁶. This gain is used in all closed loop modes. In Torque mode, on brushless controllers, the FOC's PID is used instead and this parameter is used for the speed limiting tuning.

Syntax Serial: ^KI cc nn

~KI

Syntax Scripting: setconfig(_KI, cc, nn)

Number of Arguments: 2

Argument 1: Channel

Min: 1

Max: Total Number of Motors

Argument 2:

Min: 0

Gain Type: Unsigned 32-bit

Max: 2,000,000,000

Default: 0

Where:

cc = Motor channel

nn = Integral Gain *1,000,000

Example:

^KI 1 1500000: Set motor channel 1 Integral Gain to 1.5.

Note:

Do not use default values. As a starting point, use P=2, I=0, D=0 in position modes (including Speed Position mode). Use P=0, I=1, D=0 in closed loop speed mode and in torque mode. Perform full tuning after that.

KP - PID Proportional Gain

HexCode: 2E

Description:

Sets the PID's Proportional Gain for that channel. The value is set as the gain multiplied by 10^6 . This gain is used in all closed loop modes. In Torque mode, on brushless controllers, the FOC's PID is used instead and this parameter is used for the speed limiting tuning.

Syntax Serial: ^KP cc nn
~KP

Syntax Scripting: setconfig(_KP, cc, nn)

Number of Arguments: 2

Argument 1: Channel

Min: 1

Max: Total Number of Motors

Argument 2: Gain

Min: 0

Type: Unsigned 32-bit
Max: 2,000,000,000 Default: 0

Where:

cc = Motor channel

nn = Proportional Gain * 1,000,000

Example:

^KP 1 1500000: Set motor channel 1 Proportional Gain to 1.5.

Note:

Do not use default values. As a starting point, use P=2, I=0, D=0 in position modes (including Speed Position mode). Use P=0, I=1, D=0 in closed loop speed mode and in torque mode. Perform full tuning after that.

MAC - Motor Acceleration Rate

HexCode: 33

Description:

Set the rate of speed change during acceleration for a motor channel. This command is identical to the AC realtime command. Acceleration value is in $0.1 * \text{RPM}$ per second. When using controllers fitted with encoder, the speed and acceleration value are actual RPMs. Brushless motor controllers use the internal sensor (Hall, Sin/Cos or Resolver) for measuring actual speed and acceleration will also be in actual RPM/s. When using the controller without speed sensor, the acceleration value is relative to the Max RPM configuration parameter, which itself is a user-provide number for the speed normally expected speed at full power. Assuming that the Max RPM parameter is set to 1000, and acceleration value of 10000 means that the motor will go from 0 to full speed in exactly 1 second, regardless of the actual motor speed. If value is set to 0 then the command ramp is by-passed.

Syntax Serial: ^MAC cc nn
 ~MAC [cc]

Syntax Scripting: setconfig(_MAC, cc, nn)

Number of Arguments: 2

Argument 1: Channel

Min: 1 Max: Total Number of Motors

Argument 2: Acceleration

Type: Signed 32-bit
 Min: 0 Max: 500000
 Default: 10000 = 1000.0 RPM/s

Where:

cc = Motor channel

nn = Acceleration time in 0.1 RPM per seconds

Note: In Closed Loop Torque Mode the value is translated in miliAmps/sec

MDEC - Motor Deceleration Rate

HexCode: 34

Description:

Set the rate of speed change during deceleration for a motor channel. This command is identical to the DC realtime command. Acceleration value is in 0.1*RPM per second. When using controllers fitted with encoder, the speed and deceleration value are actual RPMs. Brushless motor controllers use the internal sensor (Hall, Sin/Cos or Resolver) for measuring actual speed and acceleration will also be in actual RPM/s. When using the controller without speed sensor, the deceleration value is relative to the Max RPM configuration parameter, which itself is a user-provide number for the speed normally expected speed at full power. Assuming that the Max RPM parameter is set to 1000, and deceleration value of 10000 means that the motor will go from full speed to 0 1 second, regardless of the actual motor speed. If value is set to 0 then the command ramp is by-passed.

Syntax Serial: ^MDEC cc nn
 ~MDEC [cc]

Syntax Scripting: setconfig(_MDEC, cc, nn)

Number of Arguments: 2

Argument 1: Channel

Type: Unsigned 8-bit
 Min: 1 Max: Total Number of Motor Channels

Argument 2: Deceleration

Type: Signed 32-bit
 Min: 0 Max: 500000
 Default: 10000 = 1000.0 RPM/s

Where:

cc = Motor channel

nn = Deceleration time in 0.1 RPM per second

Note: In Closed Loop Torque Mode the value is translated in miliAmps/sec.

MLX - Molex Input

HexCode: D5

Description:

Configure this parameter in order to change the sensors that will be connected to the molex connector. In brushless controllers if SSI sensors are used then hall sensor inputs are re-mapped to the digital input pins, as dictated in the controller model's datasheet. In order to have these pins functional as hall inputs pull-up resistors should be added externally. In brushed controllers if SSI sensors are used then encoder inputs are re-mapped to the DB16 or DB25 pins as per datasheet.

Syntax Serial: ^MLX cc nn

~ MLX [cc]

Syntax Scripting: setconfig(_MLX, cc, nn)

Number of Arguments: 2

Argument 1: Channel

Min: 1 Max: Total Number of Motors

Argument 2: Molex Input

Type: Unsigned 8-bit

Min: 0 Max: 2

Default: 0

Where:

cc = Motor channel

nn = Hall Input

0: Hall Sensors (not for Brushed Controllers).

1: Encoders (not for Brushless controllers).

2: SSI Encoders

Example:

^MLX 2: Configure Molex to have SSI sensors connected.

MDIR - Motor Direction

HexCode: 77

Description:

This parameter lets you set the motor direction to inverted or direct.

Syntax Serial: ^MDIR cc nn

Where:

cc = Motor Channel

nn = 0: Not inverted

1: Inverted

Syntax Scripting: setconfig(_MDIR, cc, nn)

MMOD - Operating Mode

HexCode: 27

Description:

This parameter lets you select the operating mode for that channel. See manual for description of each mode.

Syntax Serial: ^MMOD cc nn
~MMOD [cc]

Syntax Scripting: setconfig(_MMOD, cc, nn)

Number of Arguments: 2

Argument 1: Channel

Min: 1

Max: Total Number of Motors

Argument 2: Mode

Type: Unsigned 8-bit

Min: 0

Max: 6

Default: 0 = Open loop

Where:

cc = Motor channel

nn =

0: Open-loop

1: Closed-loop speed

2: Closed-loop position relative

3: Closed-loop count position

4: Closed-loop position tracking

5: Closed-loop torque

6: Closed-loop speed position

Example:

^MMOD 2 : Select Closed loop position relative

MVEL - Default Position Velocity

HexCode: 35

Description:

This parameter is the default speed at which the motor moves while in position mode. Values are in RPMs. To change velocity while the controller is in operation, use the !S run-time command.

Syntax Serial: ^MVEL cc nn
~MVEL [cc]

Syntax Scripting: setconfig(_MVEL, cc, nn)

Number of Arguments: 2

Argument 1: Channel

Min: 1

Max: Total Number of Motors

Argument 2: Velocity

Type: Signed 32-bit

Min: 0

Max: 30000

Default: 1000 RPM

Where:

cc = Motor channel

nn = Velocity value in RPM

MXMD - Separate or Mixed Mode Select

HexCode: 05

Description:

Selects the mixed mode operation. It is applicable to dual channel controllers and serves to operate the two channels in mixed mode for tank-like steering. There are 3 possible values for this parameter for selecting separate or one of the two possible mixed mode algorithms. Details of each mixed mode is described in Section 7, chapter "Mixed Mode Select."

Syntax Serial: ^MXMD nn
~MXMD

Syntax Scripting: setconfig(_MXMD, nn)

Number of Arguments: 1

Argument 1: Mode

Type: Unsigned 8-bit

Min: 0 Max: 2

Default: 0 = Separate

Where:

nn =

0: Separate

1: Mode 1

2: Mode 2

Example:

^MXMD 0 : Set mode to separate

MXPF - Motor Max Power Forward

HexCode: 28

Description:

This parameter lets you select the scaling factor for the PWM output, in the forward direction, as a percentage value. This feature is used to connect motors with voltage rating that is less than the battery voltage. For example, using a factor of 50% it is possible to connect a 12V motor onto a 24V system, in which case the motor will never see more than 12V at its input even when the maximum power is applied.

Syntax Serial: ^MXPF cc nn
~MXPF [cc]

Syntax Scripting: setconfig(_MXPF, cc, nn)

Number of Arguments: 2

Argument 1: Channel

Min: 1

Max: Total Number of Motors

Argument 2: MaxPower

Type: Unsigned 8-bit

Min: 25

Max: 100

Default: 100%

Where:

cc = Motor channel

nn = Max Power

MXPR - Motor Max Power Reverse

HexCode: 29

Description:

This parameter lets you select the scaling factor for the PWM output, in the reverse direction, as a percentage value. This feature is used to connect motors with voltage rating that is less than the battery voltage. For example, using a factor of 50% it is possible to connect a 12V motor onto a 24V system, in which case the motor will never see more than 12V at its input even when the maximum power is applied.

Syntax Serial: ^MXPR cc nn
~MXPR [cc]

Syntax Scripting: setconfig(_MXPR, cc, nn)

Number of Arguments: 2

Argument 1: Channel

Min: 1

Max: Total Number of Motors

Argument 2: MaxPower

Type: Unsigned 8-bit

Min: 25

Max: 100

Default: 100%

Where:

cc = Motor channel

nn = Max Power

MXRPM - Max RPM Value

HexCode: 36

Description:

Commands sent via analog, pulse or the !G command only range between -1000 to +1000. The Max RPM parameter lets you select which actual speed, in RPM, will be considered the speed to reach when a +1000 command is sent. In open loop, this parameter is used together with the acceleration and deceleration settings in order to figure the ramping time from 0 to full power.

Syntax Serial: ^MXRPM cc nn
~MXRPM [cc

Syntax Scripting: setconfig(_MXRPM, cc, nn)

Number of Arguments: 2

Argument 1: Channel

Min: 1

Max: Total Number of Motors

Argument 2: RPM

Type: Unsigned 16-bit

Min: 10

Max: 65535

Default: 1000 RPM

Where:

cc = Motor channel

nn = Max RPM value

MXTRN - Number of turns between limits

HexCode: 37

Description:

This parameter is used in position mode to measure the speed when an analog or pulse feedback sensor is used. The value is the number of motor turns between the feedback value of -1000 and +1000. When encoders are used for feedback, this parameter is automatically computed from the encoder configuration, and can thus be omitted. See Section "Closed Loop Relative and Tracking Position Modes" for a detailed discussion.

Syntax Serial: ^MXTRN cc nn
~MXTRN [cc]

Syntax Scripting: setconfig(_MXTRN, cc, nn)

Number of Arguments: 2

Argument 1: Channel

Min: 1

Max: Total Number of Motors

Argument 2: Turns

Type: Signed 32-bit

Min: 10

Max: 100000

Default: 10000 = 1000.0 turns

Where:

cc = Motor channel

nn = Number of turns * 10

Example:

^MXTRN 1 2000: Set max turns for motor 1 to 200.0 turns

OVH - Overvoltage hysteresis

HexCode: 42

Description:

This voltage gets subtracted to the overvoltage limit to set the voltage at which the overvoltage condition will be cleared. For instance, if the overvoltage limit is set to 500 (50.0) and the hysteresis is set to 50 (5.0V), the MOSFETs will turn off when the voltage reaches 50V and will remain off until the voltage drops under 45V

Syntax Serial: ^OVH nn
~OVH

Syntax Scripting: setconfig(_OVH, nn)

Number of Arguments: 1

Argument 1: Voltage

Type: Unsigned 8-bit

Min: 0

Max: 255 = 25.5V

Default: 50 = 5.0V

Where:

nn = Volts * 10

Example:

^OVH 45 : Sets hysteresis at 4.5V

Note:

Make sure that overvoltage limit minus hysteresis is above the supply voltage.

OVL - Overvoltage Cutoff Limit

HexCode: 02

Description:

Sets the voltage level at which the controller must turn off its power stage and signal an Overvoltage condition. Value is in volts multiplied by 10 (e.g. 450 = 45.0V) . The power stage will turn back on when voltage dips below the Overvoltage Clearing threshold that is set with the the OVH configuration command.

Syntax Serial: ^OVL nn
~OVL

Syntax Scripting: setconfig(_OVL, nn)

Number of Arguments: 1

Argument 1: Voltage

Type: Unsigned 16-bit

Min: 100 = 10.0V

Max: See Product Datasheet

Default: See Product Datasheet

Where:

nn = Volts *10

Example:

^OVL 400 : Set Overvoltage limit to 40.0V

Note:

On firmware versions 1.5 and earlier, no hysteresis exists and the overvoltage condition is cleared as soon as the voltage dips below the overvoltage limit.

OTL - OverTemperature Cutoff Limit

HexCode: D1

Description:

Sets the Heatsink Temperature level at which the controller must turn off its power stage and signal an OverHeat condition. Value is in Celsius degrees . When temperature reaches 10 degrees below the limit, the controller starts to decrease the maximum applied power (duty cycle), by 10% for each additional degree. The power stage will turn back on gradually when heat sink temperature dips below the above limit. See Section 7, chapter "Temperature-Based Protection" for more details.

Syntax Scripting: setconfig(_OTL, nn)

Number of Arguments: 1

Argument 1: Temperature Type: Unsigned 16-bit

Min: 0 Max: 85

Where:

nn = Temperature in Celsius degrees

Example:

^OTL 75 : Set Over temperature limit to 75 Celsius degrees.

PWMF - PWM Frequency

HexCode: 06

Description:

This parameter sets the PWM frequency of the switching output stage. It can be set from 1 kHz to 30 kHz. The frequency is entered as kHz value multiplied by 10 (e.g. 185 = 18.5 kHz). Beware that a too low frequency will create audible noise and would result in lower performance operation.

Syntax Serial: ^PWMF nn
~PWMF

Syntax Scripting: setconfig(_PWMF, nn)

Number of Arguments: 1

Argument 1: Frequency

Type: Unsigned 16-bit

Min: 100

Max: 300

Default: 160 = 16.0kHz

Where:

nn = PWM Frequency *10

Example:

^PWMF 200 := Set PWM frequency to 20kHz

Note:

Do not change the default PWM frequency when operating brushless motors in sinusoidal mode.

SCPR - SSI Sensor CPR Value

HexCode: CE

Description:

This parameter will set the counts per revolution of the SSI Sensor that is attached to the controller. The CPR is the number of counts that is issued by the SSI Sensor when making a full turn. Entering a negative number will invert the counter and the measured speed polarity.

Syntax Serial: ^SCPR cc nn
~SCPR [cc]

Syntax Scripting: setconfig(_SCPR, cc, nn)

Number of Arguments: 2

Argument 1: Channel

Min: 1 Max: Total Number of SSI Sensors

Argument 2: Value

Type: Signed 32-bit
Min: -65535 Max: 65535
Default: 4096

Where:

cc = SSI Sensor channel

nn = CPR value

Example:

^SCPR 2 16384 : Sets CPR for SSI Sensor 2 to 16384 (14 bits).

SHL - SSI Sensor High Count Limit

HexCode: D8

Description:

Defines a maximum count value at which the controller will trigger an action when the SSI counter goes above that number. This feature is useful for setting up virtual or soft limit switches. This value, together with the SSI Sensor Low Count Limit, are also used in the position mode to determine the travel range when commanding the controller with a relative position command. In this case, the SSI Sensor High Limit Count is the desired position when a command of 1000 is received.

Syntax Serial: ^SHL cc nn
~SHL [cc]

Syntax Scripting: setconfig(_SHL, cc, nn)

Number of Arguments: 2

Argument 1: Channel

Min: 1 Max: Total Number of SSI Sensors

Argument 2: Value

Type: Signed 32-bit
Min: -2147M Max: 2147M
Default: +20000

Where:

cc = SSI Sensor channel

nn = Counter value

SHLA - SSI Sensor High Limit Action

HexCode: DA

Description:

This parameter lets you select what kind of action should be taken when the high limit count is reached on the SSI Sensor. The list of action is the same as in the DINA digital input action list Embedded in the parameter is the motor channel(s) to which the action should apply.

Syntax Serial: ^SHLA cc nn
 ~SHLA [cc]

Syntax Scripting: setconfig(_SHLA, cc, nn)

Number of Arguments: 2

Argument 1: Channel

Min: 1 Max: Total Number of SSI Sensors

Argument 2: Action

Type: Unsigned 8-bit
Min: 0 Max: 255
Default: 0 = No action

Where:

cc = SSI Sensor channel

aa =

0: No action

1: Safety stop

2: Emergency stop

3: Motor stop

4: Forward limit switch

5: Reverse limit switch

6: Invert direction

7: Run MicroBasic script

8: Load counter with home value

mm = mot1*16 + mot2*32 + mot3*48

SHOME - SSI Sensor Counter Load at Home Position

HexCode: DB

Description:

Contains a value that will be loaded in the selected SSI counter when a home switch is detected, or when a Home command is received from the serial/USB, or issued from a MicroBasic script. When the SSI sensor is used as absolute sensor (Absolute feedback), this value will hold an offset with which the SSI sensor counter is subtracted.

Syntax Serial: ^SHOME cc nn
 ~SHOME [cc]

Syntax Scripting: setconfig(_SHOME, cc, nn)

Number of Arguments: 2

Argument 1: Channel

Min: 1

Max: Total Number of SSI Sensors

Argument 2: Value

Type: Signed 32-bit

Min: -2147M Max: 2147M

Default: 0

Where:

cc = SSI Sensor channel

nn = Counter value to be loaded, or Counter offset.

SLL - SSI Sensor Low Count Limit

HexCode: D7

Description:

Defines a minimum count value at which the controller will trigger an action when the counter dips below that number. This feature is useful for setting up virtual or soft limit switches. This value, together with the SSI Sensor High Count Limit, are also used in the position mode to determine the travel range when commanding the controller with a relative position command. In this case, the SSI Sensor Low Limit Count is the desired position when a command of -1000 is received.

Syntax Serial: ^SELL cc nn

~SLL [cc]

Syntax Scripting: setconfig(_SLL, cc, nn)

Number of Arguments: 2

Argument 1: Channel

Min: 1

Max: Total Number of Encoders

Argument 2: Value

Type: Signed 32-bit

Min: -2147M Max: 2147M

Default: -20000

Where:

cc = SSI Sensor channel

nn = SSI Counter value

Example:

^SLL 1 -100000 : Set SSI Sensor 1 low limit to minus 100000

SLLA - SSI Sensor Low Limit Action

HexCode: D9

Description:

This parameter lets you select what kind of action should be taken when the low limit count is reached on the SSI Sensor. The list of action is the same as in the DINA digital input action list. Embedded in the parameter is the motor channel(s) to which the action should apply.

Syntax Serial: ^SLLA cc (aa + mm)

~SLLA [cc]

Syntax Scripting: setconfig(_SLLA, cc, aa)

Number of Arguments: 2

Argument 1: Channel

Min: 1 Max: Total Number of SSI Sensors

Argument 2: Action

Type: Unsigned 8-bit

Min: 0 Max: 255

Default: 0 = No action

Where:

cc = SSI Sensorchannel

aa =

0: No action

1: Safety stop

2: Emergency stop

3: Motor stop

4: Forward limit switch

5: Reverse limit switch

6: Invert direction

7: Run MicroBasic script

8: Load counter with home value

mm = mot1*16 + mot2*32 + mot3*48

SMOD - SSI Sensor Usage

HexCode: D6

Description:

This parameter defines what use the SSI Sensor is for. The encoder can be used to set command or to provide feedback (speed or position feedback). The use of SSI Sensor as feedback devices is the most common. If absolute Feedback option is set then the feedback will back the absolute value of the SSI Sensor, which is useful for Closed Loop Position Modes. Embedded in the parameter is the motor to which the SSI Sensor is associated.

Syntax Serial: ^SMOD cc (aa + mm)

^SMOD [cc]

Syntax Scripting: setconfig(_SMOD, cc, aa)

Number of Arguments: 2

Argument 1: Channel

Min: 1

Max: Total Number of SSI Sensors

Argument 2: Use

Type: Unsigned 8-bit

Min: 0 Max: 255

Default: 0 = Unused

Where:

cc = SSI Sensor channel

aa =

0: Unused

1: Command

2: Feedback

3: Absolute Feedback

mm = mot1*16 + mot2*32 + mot3*48

Example:

^SMOD 1 19 = Encoder used as absolute feedback for channel 1

THLD - Short Circuit Detection Threshold

HexCode: 04

Description:

This configuration parameter sets the threshold level for the short circuit detection. There are 4 sensitivity levels from 0 to 3.

Syntax Serial: ^THLD nn
~THLD

Syntax Scripting: setconfig(_THLD, nn)

Number of Arguments: 1

Argument 1: Threshold

Type: Unsigned 8-bit

Min: 0

Max: 3

Default: 1 = Medium Sensitivity

Where:

nn =

0: Very high sensitivity

1: Medium sensitivity

2: Low sensitivity

3: Short circuit protection disabled

Example:

^THLD 1 : Set short circuit detection sensitivity to medium.

Note:

You should never disable the short circuit protection.

TNM - Motor Torque Constant

HexCode: DF

Description:

This configuration parameter sets the motor torque constant. It is a value with which we can convert the current (A) to torque (NM) and vice versa. This value is in miliNm/Amps and is usually referred in the motor datasheets. The conversion is used by the TC and TSL commands and TRQ query.

Syntax Serial: ^TNM cc nn

~TNM cc

Syntax Scripting: setconfig(_TNM, cc, nn)

Number of Arguments: 2

Argument 1: Channel

Min: 1 Max: Total Number of Motors

Argument 2: Torque Constant Type: Signed 32-bit

Min: 0 Default: 1000 = 1Nm/Amps

Where:

cc = Motor channel

nn = Motor Torque Constant (miliNm/Amps)

Example:

^TNM 1 1523: Set torque constant for motor 1 to 1.523 Nm/Amps.

UVL - Undervoltage Limit

HexCode: 03

Description:

Sets the voltage below which the controller will turn off its power stage. The voltage is entered as a desired voltage value multiplied by 10. Undervoltage condition is cleared as soon as voltage rises above the limit.

Syntax Serial: ^UVL nn

~UVL

Syntax Scripting: setconfig(UVL, nn)

Number of Arguments: 1

Argument 1: Voltage

Type: Unsigned 16-bit

Min: 50 = 5.0V

Max: Max Voltage in Product

Datasheet

Default: 50 = 5.0V

Where:

nn = Volts *10

Example:

^UVL 100 : Set undervoltage limit to 10.0 V

Brushless Specific Commands

TABLE 15-23. Brushless Specific Commands

Command	Arguments	Description
BADJ	Channel Angle	Brushless zero angle
BADV	Channel Value	Brushless timing angle adjust
BECC	Channel Value	BEMF Coupling Constant
BFBK	Channel Sensor	Brushless feedback sesnor
BHL	Channel Value	Brushless Counter High Limit
BHLA	Channel Action	Brushless Counter High Limit Action
BHOME	Channel Value	Brushless Counter Load at Home Position
BLL	Channel Value	Brushless Counter Low Limit
BLLA	Channel Action	Brushless Counter Low Limit Action
BMOD	Channel Mode	Brushless operating mode
BPOL	Channel NbrPoles	Number of pole pairs of Brushless Motor and Speed Polarity
BZPW	Channel Amps	Brushless zero seek power level
HPO	InputNbr Value	Hall Type
HSM	InputNbr Value	Hall Sensor Map
KIF	AmpsChannel Gain	FOC PID Integral Gain
KPF	AmpsChannel Gain	FOC PID Proportional Gain
PSA	Channel Angle	Phase Shift Angle
SPOL	Channel Poles	Sin/Cos or Resolver number of poles
SSF	Channel Frequency	Sensorless Start-Up Frequency
SVT	Channel Value	BEMF Integrator Limit
SWD	InputNbr Value	Swap Windings
TID	Channel Amps	FOC Target Id
ZSMC	InputNbr Value	SinCos Calibration

BADJ - Brushless zero angle

HexCode: 60

Description:

When being in sinusoidal mode and Sin/Cos, Resolver or SSI feedback sensors are used, this configuration command stores results of automatic zero degrees angle search after performing the Motor/Sensor Setup (%clmod 2/3). The angle represents the mechanical offset between the sensor's zero position and the rotor's zero position. The value is in electrical degrees ranging from 0 to 511 for a full electrical turn. The value can then be fine tuned manually.

Syntax Serial: ^BADJ cc nn
 ~BADJ [cc]

Syntax Scripting: setconfig(_BADJ, cc, nn)

Number of Arguments:

Argument 1: Channel

Min: 1

Max: Total Number of Motors

Argument 2: Angle

Type: Signed 16-bit
 Min: -511
 Default: 0

Max: 511

Where:

cc = Motor channel
 nn = Angle

Example:

^BADJ 1 220 : Manually set the zero to 220 degrees

BADV - Brushless timing angle adjust

HexCode: 61

Description:

When operating in sinusoidal mode, this parameter shifts by number of degrees to the 3 phases rotating magnetic field. This value works symmetrically to produce the same results in both rotation direction. The value is in electrical degrees ranging from 0 to 511 for a full electrical turn.

Syntax Serial: ^BADV cc nn
 ~BADV [cc]

Syntax Scripting: setconfig(_BADV, cc, nn)

Number of Arguments: 2

Argument 1: Channel

Min: 1

Max: Total Number of Motors

Argument 2: Value

Min: -511

Type: Signed 16-bit
Max: 511

Default: 0

Where:

cc = Motor channel
nn = Angle

Example:

^BADV 1 20 : Advance motor 1 timing by 20 degrees

BECC – BEMF Coupling Constant

HexCode: BD

Description:

This configuration parameter is applicable only for sensorless motor controllers. In case of non-ideal back-EMF waveforms, this number is required to compensate for back-EMF coupling due to other two phases. This number is filled after the automatic motor tuning

Syntax Serial: ^BECC cc nn

~BECC cc

Syntax Scripting: setconfig(_BECC, cc, nn)

Number of Arguments: 2

Argument 1: Channel

Min: 1 Max: Total Number of Motors

Argument 2: Coupling Constant Type: Signed 32-bit

Min: 0 Default: 0

Where:

cc = Motor channel
nn = Coupling Constant

Example:

^BECC 1 45000: Set the coupling constant for motor 1 to 45,000.

BFBK - Brushless feedback sensor

HexCode: 63

Description:

Selects the type of rotor angle sensor to be used for brushless motors when operated in sinusoidal mode.

Syntax Serial: ^BFBK cc nn

~BFBK [cc]

Syntax Scripting: setconfig(_BFBK, cc)

Number of Arguments:

Argument 1: Channel
 Min: 1 Max: Total Number of Motors

Argument 2: Sensor
 Type: Unsigned 8-bit
 Min: 0 Max: 4
 Default: 0 = Encoder

Where:

- cc = Motor channel
- nn =
- 0: Encoder
- 1: Hall
- 2: Hall + Encoder
- 3: SPI/SSI sensor
- 4: Sin/Cos sensor
- 5: Resolver

BHL - Brushless Counter High Limit

HexCode: 3E

Description:

This parameter allows you to define a minimum brushless count value at which the controller will trigger an action when the counter rises above that number. This feature is useful for setting up virtual or soft limit switches. This value, together with the Low Count Limit, are also used in the position mode to determine the travel range when commanding the controller with a relative position command. In this case, the Low Limit Count is the desired position when a command of 1000 is received

Syntax Serial: ^BHL cc nn
 ~BHL [cc]

Syntax Scripting: setconfig(_BHL, cc, nn)

Number of Arguments: 2

Argument 1: Channel
 Min: 1 Max: Total Number of Motors

Argument 2: Value
 Type: Signed 32-bit
 Min: -2147M Max: +2147M
 Default: 20000

Where:

- cc = Motor channel
- nn = Counter value

Example:

^BHL 10000 : Set brushless counter high limit

Note:

Counter is not an absolute position. A homing sequence is necessary to set a reference position.

BHLA - Brushless Counter High Limit Action

HexCode: 40

Description:

This parameter lets you select what kind of action should be taken when the high limit count is reached on the brushless counter. The list of action is the same as in the DINA digital input action list. Embedded in the parameter is the motor channel(s) to which the action should apply.

Syntax Serial: ^BHLA cc nn
 ~BHLA [cc]

Syntax Scripting: setconfig(_BHLA, cc, nn)

Number of Arguments: 2

Argument 1: Channel

Min: 1

Max: Total Number of Motor

Argument 2: Action

Type: Unsigned 8-bit

Min: 0

Max: 255

Default: 0 = No action

Where:

cc = Motor channel

aa =

0 : No action

1: Safety stop

2: Emergency stop

3: Motor stop

4: Forward limit switch

5: Reverse limit switch

6: Invert direction

7: Run MicroBasic script

8: Load counter with home value

mm = mot1*16 + mot2*32 + mot3*48

Example:

^BHLA 1 36 : Forward limit switch for motor 2 (4 + 32)

BHOME - Brushless Counter Load at Home Position

HexCode: 3C

Description:

This parameter contains a value that will be loaded in the brushless hall sensor counter when a home switch is detected, or when a Home command is received from the serial/USB, or issued from a MicroBasic script.

Syntax Serial: ^BHOME cc nn
 ~BHOME [cc]

Syntax Scripting: setconfig(_BHOME, cc, nn)

Number of Arguments: 2

Argument 1: Channel

Min: 1

Max: Total Number of Motors

Argument 2: Value

Type: Signed 32-bit

Min: -2147M

Max: +2147M

Default: 0

Where:

cc = Motor channel

nn = Counter value to be loaded

Example:

^BHOME 1 10000 : load brushless counter with 10000 when Home command is received

Note:

Change counter only while in open loop if brushless counter is used for speed or position feedback

BLL - Brushless Counter Low Limit

HexCode: 3D

Description:

This parameter defines a minimum brushless count value at which the controller will trigger an action when the counter dips below that number. This feature is useful for setting up virtual or soft limit switches. This value, together with the High Count Limit, are also used in the position mode to determine the travel range when commanding the controller with a relative position command. In this case, the Low Limit Count is the desired position when a command of -1000 is received

Syntax Serial: ^BLL cc nn
 ~BLL [cc]

Syntax Scripting: setconfig(_BLL, cc, nn)

Number of Arguments: 2

Argument 1: Channel

Min: 1

Max: Total Number of Motors

Argument 2: Value

Type: Signed 32-bit

Min: -2147M

Default: -20000

Max: +2147M

Where:

cc = Motor channel

nn = Counter value

Example:

`^BLL 1 -10000` : Set motor 1 brushless counter low limit

Note:

Counter is not an absolute position. A homing sequence is necessary to set a reference position.

BLLA - Brushless Counter Low Limit Action

HexCode: 3F

Description:

This parameter lets you select what kind of action should be taken when the low limit count is reached on the brushless counter. The list of action is the same as in the DINA digital input action list. Embedded in the parameter is the motor channel(s) to which the action should apply.

Syntax Serial: `^BLLA cc aa`

`~BLLA [cc]`

Syntax Scripting: `setconfig(_BLLA, cc, aa)`

Number of Arguments: 2

Argument 1: Channel

Min: 1

Max: Total Number of Motors

Argument 2: Action

Type: Unsigned 8-bit

Min: 0

Default: 0 = No action

Max: 255

Where:

cc = Motor channel

aa =

0: No action

1: Safety stop

2: Emergency stop

- 3: Motor stop
- 4: Forward limit switch
- 5: Reverse limit switch
- 6: Invert direction
- 7: Run MicroBasic script
- 8: Load counter with home value

$$mm = mot1*16 + mot2*32 + mot3*48$$

Example:

^BLLA 1 37 : Reverse limit switch for motor 2 (5 + 32)

BMOD - Brushless operating mode

HexCode: 5F

Description:

Selects the operating mode when controlling brushless motors. Additional settings apply for each mode.

Syntax Serial: ^BMOD cc nn
 ~BMOD [cc]

Syntax Scripting: setconfig(_BMOD, cc, nn)

Number of Arguments: 2

Argument 1: Channel

Min: 1

Max: Total Number of Motors

Argument 2: Mode

Type: Unsigned 8-bit

Min: 0

Max: 2

Default: 0 = Trapezoidal

Where:

cc = Motor channel

nn =

0: Trapezoidal

1: Sinusoidal

2: Sensorless

3: AC Induction

Note:

After changing this setting, the motor will perform a reference search when selecting sinusoidal mode with encoder feedback.

BPOL - Number of Pole Pairs and Speed Polarity of Brushless Motor

HexCode: 39

Description:

This parameter is used to define the number of pole pairs of the brushless motor connected to the controller. This value is used to convert the hall sensor transition counts into actual RPM and number of motor turns. Entering a negative number will invert the counter and the measured speed polarity.

Syntax Serial: ^BPOL cc nn
~BPOL

Syntax Scripting: setconfig(_BPOL, cc, nn)

Number of Arguments: 2

Argument 1: Channel

Min: 1

Max: Total Number of Motors

Argument 2: Number of Pole Pairs

Type: Signed 8-bit

Min: -127

Max: +127

Default: 2

Where:

cc = Motor channel

nn = Number of pole pairs

BZPW - Brushless zero seek power level

HexCode: 62

Description:

Sets the level of Amps to be applied to the motor coils during Motor/Sensor Setup. Motor/Sensor Setup is automatically initiated every time the controller is powered up when sinusoidal with encoder feedback is selected. Motor/Sensor Setup is necessary to be performed only once in the other cases.

Syntax Serial: ^BZPW cc nn
~BZPW [cc]

Syntax Scripting: setconfig(_BZPW, cc, nn)

Number of Arguments: 2

Argument 1: Channel

Min: 1

Max: Total Number of Motors

Argument 2: Amps

Type: Unsigned 16-bit
Min: 0
Default: 50 = 5.0A

Where:

cc = Motor channel
nn = Amps x 10

HPO - Hall Sensor Position

HexCode: A5

Description:

This parameter selects the Hall sensor spacing in the motor. Practically all brushless motors use Hall sensors with 120 degrees spacing. Some motors have Hall sensors with 60 degrees. Change this parameter only if the motor's manual clearly specifies 60 degrees spacing.

Syntax Serial: ^HPO cc nn
~HPO [cc]

Syntax Scripting: setconfig_LHPO, cc, nn)

Number of Arguments: 2

Argument 1: Channel

Min: 1 Max: Total Number of Motors

Argument 2: Hall Position

Type: Unsigned 8-bit

Min: 0 Max: 1

Default: 0

Where:

cc = Motor channel

nn = Hall Sensor Position

0: 120degree

1: 60degree

Example:

^HPO 1 1: Configure that the Hall Sensor of motor 1 are spaced by 60 degrees.

HSM - Hall Sensor Map

HexCode: A3

Description:

Configure this parameter to match the ABC hall sensor cable pattern with the UVW motor windings wire pattern connected to the controller. For each hall sensor cable order and motor wire order, there are 6 combinations, one of which will make the motor spin smoothly and efficiently in both directions. Try each of the 6 available values of HSM (0-5) and retain the one that will make the motor spin in both directions while drawing the same low current. Applicable only in Hall Trapezoidal mode.

Syntax Serial: ^HSM cc nn

~ HSM [cc]

Syntax Scripting: setconfig(_HSM, cc, nn)

Number of Arguments: 2

Argument 1: Channel

Min: 1 Max: Total Number of Motors

Argument 2: Hall Sensor Map

Type: Unsigned 8-bit

Min: 0 Max: 5

Default: 0

Where:

cc = Motor channel

nn = Motor's Hall Sensor Map

Example:

^HSM 1 1: Set Hall Sensor Map for motor 1 to value 1.

KIF - FOC PID Integral Gain

HexCode: 8E

Description:

On brushless motor controller operating in sinusoidal mode, this parameter sets the Integral gain in the PI that is used for Field Oriented Control. Two gains can be set for each motor channel, in order to control the Flux and Torque current. When operating in trapezoidal mode the gains for the Torque current are used for closed loop torque mode.

Syntax Serial: ^KIF cc nn

~KIF [cc]

Syntax Scripting: setconfig(_KIF, cc)

Number of Arguments:

Argument 1: AmpsChannel

Min: 1

Max: 2 * Total Number of Motors

Argument 2: Gain Type: Unsigned 32-bit

Min: 0 Max: 2,000,000,000

Default: 0

Where:

cc (single channel) =

1: Flux Gain

2: Torque Gain

cc (dual channel) =

1: Flux Gain for motor 1

2: Flux Gain for motor 2

3: Torque Gain for motor 1

4: Torque Gain for motor 2

nn = Gain * 1,000,000

Example:

^KIF 1 230000: Set motor channel 1 Flux Integral Gain to 0.23.

KPF - FOC PID Proportional Gain

HexCode: 8D

Description:

On brushless motor controller operating in sinusoidal mode, this parameter sets the Proportional gain in the PI that is used for Field Oriented Control. Two gains can be set for each motor channel, in order to control the Flux and Torque current. When operating in trapezoidal mode the gains for the Torque current are used for closed loop torque mode.

Syntax Serial: ^KPF cc nn

~KPF [cc]

Syntax Scripting: setconfig(_KPF, cc)

Number of Arguments:

Argument 1: AmpsChannel

Min: 1

Max: 2 * Total Number of Motors

Argument 2: Gain Type: Unsigned 32-bit

Min: 0

Max: 2,000,000,000 Default: 0

Where:

cc (single channel) =

1: Flux Gain

2: Torque Gain

cc (dual channel) =
1: Flux Gain for motor 1
2: Flux Gain for motor 2
3: Torque Gain for motor 1
4: Torque Gain for motor 2
nn = Gain * 1,000,000

Example:

^KPF 4 230000: Set motor channel 2 Torque Proportional Gain to 0.23.

PSA - Phase Shift Angle

HexCode: E1

Description:

When being in sinusoidal mode and Sin/Cos or Resolver feedback sensors are used, this configuration command defines the Phase Shift Angle between the Sin and Cos signals. The value is in degrees ranging from 0 to 511. If the sensor is a regular Sin/Cos or Resolver Sin/Cos sensor, the phase shift angle is 90° degrees, so we need to configure $90 * 512 / 360 = 128$. If not then the sensor manufacturer should inform about the phase shift angle.

Syntax Serial: ^PSA cc nn

~PSA [cc]

Syntax Scripting: setconfig(_PSA, cc, nn)

Number of Arguments:

Argument 1: Channel

Min: 1 Max: Total Number of Motors

Argument 2: Angle

Type: Signed 16-bit

Min: -511 Max: 511

Default: 128

Where:

cc = Motor channel

nn = Angle

Example:

^PSA 1 171 : Set the phase shift angle to $171 * 360 / 512 = 120^\circ$ degrees.

SPOL - Sin/Cos, Resolver or SSI sensor number of poles

HexCode: 41

Description:

Number of poles of the Sin/Cos, Resolver or SSI angle sensor used in sinusoidal mode with brushless motors

Syntax Serial: ^SPOL cc nn
 ~SPOL [cc]

Syntax Scripting: setconfig(_SPOL, cc, nn)

Number of Arguments: 2

Argument 1: Channel

Min: 1

Max: Total Number of Motors

Argument 2: Number

Type: Unsigned 8-bit
 Min: 1
 Default: 1

Max: 255

Where:

cc = Motor channel
 nn = Number of poles

SSF – Sensorless Start-Up Frequency

HexCode: C0

Description:

This configuration parameter is applicable only for sensorless motor controllers. This is the minimum frequency (electrical Hz) at which the motor will always try to commutate if slowed down.

Syntax Serial: ^SSF cc nn
 ~SSF [cc]

Syntax Scripting: setconfig(_SSF, cc, nn)

Number of Arguments:

Argument 1: Channel

Min: 1 Max: Total Number of Motors

Argument 2: Frequency

Type: Unsigned 16-bit
 Min: 1 Max: 35000
 Default: 100

Where:

cc = Motor channel
 nn = Frequency (Hz*10)

Example:

^SSF 1 150 : Set the sensorless start-up frequency of motor 1 at 15,0Hz.

SVT – BEMF Integrator Limit

HexCode: BE

Description:

This configuration parameter is applicable only for sensorless motor controllers. This defines the limit to which the back-EMF of a given phase should be integrated to commute. It is representation of maximum flux linkage of the rotor. This number is filled after the automatic motor tuning.

Syntax Serial: ^SVT cc nn

~SVT [cc]

Syntax Scripting: setconfig(_SVT, cc, nn)

Number of Arguments:

Argument 1: Channel

Min: 1 Max: Total Number of Motors

Argument 2: Integrator Limit

Type: Unsigned 32-bit

Min: 0 Default: 1000

Where:

cc = Motor channel

nn = Flux Linkage (miliWebber)

Example:

^SVT 1 1500 : Set the BEMF Integrator Limit motor 1 at 1,500 miliWebber.

SWD - Swap Windings

HexCode: A4

Description:

The concept of swap windings (can also be termed as sensor polarity) is a relative relationship between sensor direction and stator magnetic field rotational direction. During calibration if angle, reported by the sensor, is changing in same direction as angle commanded to the stator then Swap Windings should be "None", else "Swapped".

In case of Hall + Encoder, two different Swap Windings are needed, one for hall and one for encoder. So, instead we use 2 bits of same variable Bit 1 for Hall and Bit 0 for Encoder. The following table shows the truth table for swap windings

SWD Value	BIT 1	BIT 0	Swap for Hall (Bit 1)	Swap for Encoder (Bit 0)	Meaning
0	0	0	NO	NO	None
1	0	1	NO	YES	Swapped
2	1	0	YES	NO	Hall only Swapped
3	1	1	YES	YES	Hall+Encoder Swapped

Syntax Serial: ^SWD cc nn

~ SWD [cc]

Syntax Scripting: setconfig(_SWD, cc, nn)

Number of Arguments: 2

Argument 1: Channel

Min: 1 Max: Total Number of Motors

Argument 2: Swap Windings

Type: Unsigned 8-bit

Min: 0 Max: 3

Default: 0

Where:

cc = Motor channel

nn = Motor's Swap Windings

0: None, Angle up-counting for clockwise direction

1: Swapped, Angle down-counting for clockwise direction

2: Hall only Swapped, Angle up-counting for clockwise direction for encoder and Angle down-counting for clockwise direction for Hall sensor.

3: Hall+Encoder Swapped, Angle down-counting for clockwise direction for encoder and Angle down-counting for clockwise direction for Hall sensor.

Example:

^SWD 1 1: Set angle down-counting for clockwise direction for motor 1.

TID - FOC Target Id

HexCode: 8F

Description:

In brushless motors operating in sinusoidal mode, this command sets the desired Flux (also known as Direct Current Id) for Field Oriented Control. This value must be 0 in typical application. A non-zero value creates field weakening and can be used to achieve higher rotation speed

Syntax Serial: ^TID cc nn
 ~TID [cc]

Syntax Scripting: setconfig(_TID, cc, nn)

Number of Arguments: 2

Argument 1: Channel
 Min: 1 Max: Total Number of Motors

Argument 2: Amps
 Type: Signed 32-bit
 Min: 0
 Default: 0

Where:

cc = Motor Channel
 nn = Amps * 10

ZSMC - SinCos Calibration

HexCode: 46

Description:

Shows Sin/Cos calibration value that are captured after the completion of the Motor/Sensor Setup. Values are not to be altered manually. When non-zero values are returned after querying ZSMC, this indicates that the setup has been successfully completed at one time or another.

Syntax Serial: ^ZSMC cc nn
 ~ZSMC [cc]

Syntax Scripting: setconfig(_ZSMC, cc)

Number of Arguments:

Argument 1: InputNbr
 Min: 1 Max: 6

Argument 2: Value
 Type: Signed 16-bit

Where:

cc =

- 1: Sine Zero Point for motor 1
- 2: Cosine Zero Point for motor 1
- 3: Cosine/Sine Ratio for motor 1
- 4: Sine Zero Point for motor 2
- 5: Cosine Zero Point for motor 2
- 6: Cosine/Sine Ratio for motor 2

nn = Calibration value

AC Induction Specific Commands

TABLE 15-24. AC Induction Specific Commands

Command	Arguments	Description
ILM	Inductance	Mutual Inductance
ILLR	Inductance	Rotor Leakage Inductance
IRR	Resistance	Rotor Resistance
MPW	MotorPower	Minimum Power
MXS	SlipFrequency	Optimal Slip Frequency
RFC	Channel Amps	Rotor Flux Current
VPH	VoltsperHertz	AC Induction Motor Volts per HZ

VPH - AC Induction Volts per Hertz

HexCode: 95

Description:

This parameter is only used for AC Induction controllers. Each motor has as specification a Volts per Hertz value with which the frequency can be determined when specific voltage is applied.

Syntax Serial: ^VPH cc nn
~VPH [cc]

Syntax Scripting: setconfig(_VPH, cc, nn)

Number of Arguments: 2

Argument 1: Channel

Min: 1

Max: Total Number of Motors

Argument 2: VoltsPerHz

Type: Unsigned 16-bit

Min: 0

Max: 65535

Default: 20000

Where:

cc = Motor channel
nn = Motor's Volts per Hertz * 1000

Example:

^VPH 1 200: Set Volts per Hertz to value 0.200

ILM - Mutual Inductance

HexCode: 9B

Description:

This parameter is only used for AC Induction controllers when operating in FOC mode and contains motor's mutual inductance (coupled to both stator and rotor).

Syntax Serial: ^ILM cc nn
~ ILM [cc]

Syntax Scripting: setconfig(_ILM, cc, nn)

Number of Arguments: 2

Argument 1: Channel

Min: 1 Max: Total Number of Motors

Argument 2: Mutual Inductance

Type: Unsigned 32-bit

Min: 0 Max: 10000

Default: 10

Where:

cc = Motor channel
nn = Motor's Mutual Inductance in μH .

Example:

^RFC 1 961: Set Mutual Inductance of motor 1 to value 961 μH .

ILLR - Rotor Leakage Inductance

HexCode: 9A

Description:

This parameter is only used for AC Induction controllers when operating in FOC mode and contains the rotor's per phase leakage inductance of the motor. This value can be obtained from the motor supplier.

Syntax Serial: ^ILLR cc nn
~ ILLR [cc]

Syntax Scripting: setconfig(_ILLR, cc, nn)

Number of Arguments: 2

Argument 1: Channel

Min: 1 Max: Total Number of Motors

Argument 2: Rotor Leakage Inductance

Type: Unsigned 32-bit

Min: 0 Max: 10000

Default: 10

Where:

cc = Motor channel

nn = Motor's Rotor Leakage Inductance in μH .

Example:

^RFC 1 67: Set Rotor Leakage Inductance of motor 1 to value 67 μH .

IRR - Rotor Resistance

HexCode: 99

Description:

This parameter is only used for AC Induction controller when operating in FOC mode and contains the resistance per phase of the rotor. This value can be obtained from the motor supplier.

Syntax Serial: ^IRR cc nn
~ IRR [cc]

Syntax Scripting: setconfig(_IRR, cc, nn)

Number of Arguments: 2

Argument 1: Channel

Min: 1 Max: Total Number of Motors

Argument 2: Rotor Resistance

Type: Unsigned 32-bit
Min: 1 Max: 500000
Default: 20000

Where:

cc = Motor channel

nn = Motor's Rotor Resistance in micro-ohm.

Example:

^IRR 1 24500: Set Rotor Resistance of motor 1 to value 24500 $\mu\Omega$.

MPW - Minimum Power

HexCode: 97

Description:

This parameter is only used for AC Induction controllers when operating in Volts per Hertz mode. It defines a minimum PWM output value so that there is always a minimal of rotor flux to create induction.

Syntax Serial: ^MPW cc nn

~MPW [cc]

Syntax Scripting: setconfig(_MPW, cc, nn)

Number of Arguments: 2

Argument 1: Channel

Min: 1 Max: Total Number of Motors

Argument 2: Minimum Power

Type: Unsigned 16-bit

Min: 0 Max: 1000

Default: 100

Where:

cc = Motor channel

nn = Motor's Minimum Power in % of PWM Level

Example:

^MPW 1 200: Set Minimum Power for motor 1 to value 20.0% PWM Level.

MXS - Optimal Slip Frequency

HexCode: 96

Description:

This parameter is only used for AC Induction controllers. The optimal slip is the value that the controller will work to maintain while operating in Constant Slip mode.

Syntax Serial: ^MXS cc nn
~MXS [cc]

Syntax Scripting: setconfig(_MXS, cc, nn)

Number of Arguments: 2

Argument 1: Channel

Min: 1 Max: Total Number of Motors

Argument 2: Optimal Slip Frequency

Type: Unsigned 16-bit

Min: 0 Max: 65535

Default: 50

Where:

cc = Motor channel

nn = Motor's Optimal Slip Frequency in Hertz * 10

Example:

^MXS 1 60: Set Optimal Slip for motor 1 to value 6.0Hz

RFC - Rotor Flux Current

HexCode: 98

Description:

This parameter is only used for AC Induction controller. This value is the stator current component (Id) for rotor flux production when FOC modes are selected.

Syntax Serial: ^RFC cc nn
~ RFC [cc]

Syntax Scripting: setconfig(_RFC, cc, nn)

Number of Arguments: 2

Argument 1: Channel

Min: 1 Max: Total Number of Motors

Argument 2: Rotor Flux Current

Type: Unsigned 16-bit

Min: 0 Max: 500

Default: 10

Where:

cc = Motor channel

nn = Motor's Rotor Flux Current in Amps * 10

Example:

^RFC 1 50: Set Rotor Flux Current for motor 1 to value 5A.

CAN Communication Commands

This section describes all the configuration parameters uses for CANbus operation.

TABLE 15-25. CANbus Commands

Command	Arguments	Description
CAS	Rate	CANOpen Auto start
CBR	BitRate	CAN Bit Rate
CEN	Mode	CAN Enable
CHB	HeartBeat	CAN Heartbeat
CLSN	Address	CAN Listening Node
CNOD	Address	CAN Node Address
CSRT	Rate	MiniCAN SendRate
CTPS	TPDOnbr Rate	CANOpen TPDO SendRate
CTT	None	CANOpen Transmission Type
FSA	None	DS402 FSA

CAS - CANOpen Auto start

HexCode: 5A

Description:

Determines if device is an active CANOpen node at power up. When set, node is in operational state at power up without the need to receive a start command.

Syntax Serial: ^CAS nn
~CAS

Syntax Scripting: setconfig(_CAS, nn)

Number of Arguments: 1

Argument 1: Rate

Type: Unsigned 8-bit

Min: 0 Max: 1

Default: 0 = Off

Where:

nn =

0: Device is in pre-operational state at power-up.

1: Device is in operational state at power up.

CBR - CAN Bit Rate

HexCode: 58

Description:

Sets the CAN bus bit rate

Syntax Serial: ^CBR nn

~CBR

Syntax Scripting: setconfig(_CBR, nn)

Number of Arguments: 1

Argument 1: BitRate

Type: Unsigned 8-bit

Min: 0

Default: 3 = 250K

Max: 5

Where:

nn =

0: 1000K

1: 800K

2: 500K

3: 250K

4: 125K

CEN - CAN Enable

HexCode: 56

Description:

Enables CAN and selects the CAN protocol

Syntax Serial: ^CEN nn

~CNOD

Syntax Scripting: setconfig(_CEN, nn)

Number of Arguments: 1

Argument 1: Mode

Type: Unsigned 8-bit

Min: 0

Max: 5

Where:

nn =

0: Disabled

1: CANOpen

2: MiniCAN

3: RawCAN

4: RoboCAN

5: MiniJ1939

CHB - CAN Heartbeat

HexCode: 59

Description:

Sets the rate in milliseconds at which the controller will send a heartbeat frame on the CAN bus. Heartbeat is sent when either MiniCAN, RawCAN, CANOpen are selected. A dedicated, non-user-alterable Heartbeat frame is sent when RoboCAN is selected.

Syntax Serial: ^CHB nn

Syntax Scripting: setconfig(_CHB, nn)

Number of Arguments: 1

Argument 1: HeartBeat

Type: Unsigned 16-bit

Min: 0

Max: 65536

Default: 100ms

Where:

nn = Heartbeat rate in ms

CLSN - CAN Listening Node

HexCode: 5B

Description:

In RawCAN and MiniCAN mode, this parameter filters the incoming frames in order to capture only those originating from a given node address. In RawCAN, entering 0 disables the filter and will cause all incoming frames to be captured

Syntax Serial: ^CLSN nn
~CSLD

Syntax Scripting: setconfig(_CLSN, nn)

Number of Arguments: 1

Argument 1: Address

Type: Unsigned 8-bit
 Min: 0 Max: 127
 Default: Product dependent

Where:

nn =
 0: Listen to all nodes (RawCAN only)
 1-127: Capture frames from specific node id only

CNOD - CAN Node Address

HexCode: 57

Description:

Stores the product's address on the CAN bus

Syntax Serial: ^CNOD nn
 ~CNOD

Syntax Scripting: setconfig(CNOD, nn)

Number of Arguments: 1

Argument 1: Address

Type: Unsigned 8-bit
 Min: 0 Max: 127
 Default: See datasheet

Where:

nn = Node address

CSRT - MiniCAN SendRate

HexCode: 5C

Description:

Rate, in ms, at which MiniCAN frames are sent.

Syntax Serial: ^CSRT nn
 ~CSRT

Syntax Scripting: setconfig(CSRT, nn)

Number of Arguments: 1

Argument 1: Rate

Type: Unsigned 8-bit
 Min: 0 Max: 65536
 Default: 100ms

Where:

nn = Rate in ms. No frames sent. if value is 0

CTPS - CANOpen TPDO SendRate

HexCode: 5D

Description:

Sets the send rate for each of the 4 TPDOs when CANOpen is enabled.

Syntax Serial: ^CTPS nn mm

Syntax Scripting: setconfig(_CTPS, nn, mm)

Number of Arguments: 2

Argument 1: TPDOnbr

Min: 1

Max: 4

Argument 2: Rate

Type: Unsigned 16-bit

Min: 0

Max: 65536

Default: 0 = Off

Where:

nn = TPDO number, 1 to 4

mm = Rate in ms

Note:

If mm = 0, the TPDO is not transmitted

CTT - CANOpen Transmission Type

HexCode: 70

Description:

Sets the transmission type of the respective TPDOs.

Syntax Serial: ^CTT nn mm

Syntax Scripting: setconfig(_CTT, nn, mm)

Number of Arguments: 2

Argument 1: TPDOnbr

Min: 1 Max:4

Argument 2: Type

Min: 0 Max:255

Where:

nn = TPDO number, 1 to 4

mm = Transmission Type

FSA – DS402 PDS Finite State Automation Enable

HexCode: CC

Description:

Enables or disables the PDS Finite State Automation (FSA), as dictated in DS402 specification.

Syntax Serial: ^FSA nn

~FSA

Syntax Scripting: setconfig(_FSA, nn)

Number of Arguments: 1

Argument 1: Mode

Type: Unsigned 8-bit

Min: 0 Max:1

Default: 0 = Off

Where:

nn =

0: FSA is inactive.

1: FSA is active.

TCP Communication Commands

This section describes all the configuration parameters uses for TCP operation.

TABLE 15-26. TCP Commands

Command	Arguments	Description
DHCP	Enable	Enable DHCP
GWA	IP Octet	Gateway Address
IPA	IP Octet	IP Address
IPP	None	IP Port
PDNS	IP Octet	Primary DNS
SBM	IP Octet	Subnet Mask
SDNS	IP Octet	Secondary DNS
WMOD	Mode	TCP Mode

DHCP - Enable DHCP

HexCode: 6F

Description:

Configure this parameter in order to enable the DHCP. The default value for DHCP service is disabled. When DHCP is Disabled the user configured IP address is used by the controller to access the network. By enabling DHCP service, the controller uses the IP address provided by the DHCP server.

Syntax Serial: ^DHCP nn
~ DHCP

Syntax Scripting: setconfig(_DHCP, nn)

Number of Arguments: 1

Argument 1: Enable DHCP

Type: Unsigned 8-bit
Min: 0 Max: 1
Default: 0

Where:

nn = Enable DHCP
0: Disabled.
1: Enabled.

Example:

^DHCP 1: Enable DHCP

GWA - Gateway Address

HexCode: 69

Description:

Configure this parameter in order to set the Gateway Address of your controller's network. Gateway Address option includes 4 values representing each octet in the IP address v4 format. The default Gateway Address value is 192.168.1.1.

Syntax Serial: ^GWA cc nn
~GWA

Syntax Scripting: setconfig(_GWA, cc, nn)

Number of Arguments: 2

Argument 1: IP Octet

Type: Unsigned 8-bit
Min: 1 Max: 4

Argument 2: Gateway Address

Type: Unsigned 8-bit
Min: 0 Max: 255
Default:

Octet	Value
1	192
2	168
3	1
4	1

Where:

cc = octet
nn = octet value

Example:

`^GWA 1 192_^GWA 2 168_^GWA 3 2_^GWA 4 1`: Set Gateway Address 192.168.2.1.

IPA - IP Address

HexCode: 68

Description:

Configure this parameter in order to set the IP Address. IP Address option includes 4 values representing each octet in the IP address v4 format. The default IP address, if DHCP is disabled, is 192.168.1.20.

Syntax Serial: `^IPA cc nn`

`~IPA`

Syntax Scripting: `setconfig(_IPA, cc, nn)`

Number of Arguments: 2

Argument 1: IP Octet

Type: Unsigned 8-bit
Min: 1 Max: 4

Argument 2: IP Address

Type: Unsigned 8-bit
Min: 0 Max: 255
Default:

Octet	Value
1	192
2	168
3	1
4	20

Where:

cc = octet
nn = octet value

Example:

`^IPA 1 192_^IPA 2 168_^IPA 3 1_^IPA 4 100`: Set IP Address 192.168.1.100.

IPP - IP Port

HexCode: 6B

Description:

Configure this parameter in order to set the IP Port. Default IP Port value is 9761. The IP address combined with the IP Port value are used to connect to the controller.

Syntax Serial: ^IPP nn

~IPP

Syntax Scripting: setconfig(_IPP, nn)

Number of Arguments: 1

Argument 1: IP Port

Type: Unsigned 16-bit

Min: 0 Max: 65535

Default: 9761

Where:

nn = IP Port

Example:

^IPP 1300: Set IP Port 1300.

PDNS - Primary DNS

HexCode: 6D

Description:

Configure this parameter in order to set the address of the primary DNS server. Primary DNS option includes 4 values representing each octet in the IP address v4 format. Primary DNS server default address is 192.168.1.1.

Syntax Serial: ^PDNS cc nn

~PDNS

Syntax Scripting: setconfig(_PDNS, cc, nn)

Number of Arguments: 2

Argument 1: IP Octet

Type: Unsigned 8-bit

Min: 1 Max: 4

Argument 2: Primary DNS

Type: Unsigned 8-bit

Min: 0 Max: 255

Default:

Octet	Value
1	192
2	168
3	1
4	1

Where:

cc = octet

nn = octet value

Example:

`^PDNS 1 192_^PDNS 2 168_^PDNS 3 2_^PDNS 4 1`: Set Primary DNS 192.168.2.1.

SBM - Subnet Mask

HexCode: 6A

Description:

Configure this parameter in order to set the Subnet Mask to define the range of IP addresses that can be used in your network. Subnet Mask option includes 4 values representing each octet in the IP address v4 format. Devices within the same sub-network can communicate directly. Using the default subnet mask, all devices with the first 3 bytes identical are located in the same sub-network and almost 256 (not all 256 values may be used as a host IP) unique host devices may be used in the network. Subnet Mask option includes 4 values representing each octet in the IP address. The default Subnet Mask value is 255.255.255.0.

Syntax Serial: `^SBM cc nn`

`~SBM`

Syntax Scripting: `setconfig(_SBM, cc, nn)`

Number of Arguments: 2

Argument 1: IP Octet

Type: Unsigned 8-bit

Min: 1 Max: 4

Argument 2: Subnet Mask

Type: Unsigned 8-bit

Min: 0 Max: 255

Default:

Octet	Value
1	255
2	255
3	255
4	0

Where:

cc = octet
nn = octet value

Example:

`^SBM 1 255_^SBM 2 255_^SBM 3 254_^SBM 4 0`: Set Gateway Address
255.255.254.0.

SDNS - Primary DNS

HexCode: 6E

Description:

Configure this parameter in order to set the address of the secondary DNS server. Secondary DNS option includes 4 values representing each octet in the IP address v4 format. Secondary DNS server default address is 0.0.0.0. By setting the secondary DNS server to 0.0.0.0 then automatically a secondary DNS server address is assigned. Since the secondary server address is a backup, there is no need to be configured, unless necessary.

Syntax Serial: `^SDNS cc nn`

`~SDNS`

Syntax Scripting: `setconfig(_SDNS, cc, nn)`

Number of Arguments: 2

Argument 1: IP Octet

Type: Unsigned 8-bit
Min: 1 Max: 4

Argument 2: Primary DNS

Type: Unsigned 8-bit
Min: 0 Max: 255
Default:

Octet	Value
1	192
2	168
3	1
4	1

Where:

cc = octet
nn = octet value

Example:

`^SDNS 1 192_^SDNS 2 168_^SDNS 3 2_^SDNS 4 1`: Set Secondary DNS 192.168.2.1.

WMOD - TCP Mode

HexCode: 67

Description:

Configure this parameter in order to enable the TCP functionality. When the TCP mode is set as Disabled the Ethernet hub is idle and no data packets are being transmitted or received. To communicate via TCP/IP this parameter must be set to Enabled. For communicating via Modbus TCP or Modbus TCP over RTU, TCP Mode must be set to Enabled.

Syntax Serial: ^WMOD nn

~WMOD

Syntax Scripting: setconfig(_WMOD, nn)

Number of Arguments: 1

Argument 1: TCP Mode

Type: Unsigned 8-bit

Min: 0 Max: 1

Default: 0

Where:

nn = TCP Mode

0: Disabled.

1: Enabled.

Example:

^WMOD 1: Enable TCP functionality.