

# WANDERER LCD

PWM Solar Charge Controller

**10A | 12V/24V**

Version 1.2



## **Important Safety Instructions**

**Please save these instructions.**

This manual contains important safety, installation, and operating instructions for the charge controller. The following symbols are used throughout the manual:

**WARNING**

Indicates a potentially dangerous condition. Use extreme caution when performing this task.

**CAUTION**

Indicates a critical procedure for safe and proper operation of the controller

**NOTE**

Indicates a procedure or function that is important to the safe and proper operation of the controller.

### ■ **General Safety Information**

- Read all of the instructions and cautions in the manual before beginning the installation.
- There are no serviceable parts for this controller. Do **NOT** disassemble or attempt to repair the controller.
- Make sure all connections going into and from the controller are tight. There may be sparks when making connections, therefore, make sure there are not flammable materials or gases near installation.

### ■ **Charge Controller Safety**

- **NEVER** connect the solar panel array to the controller without a battery. Battery must be connected first. This may cause a dangerous occurrence where the controller would experience a high open circuit voltage at the terminals.
- Ensure input voltage does not exceed **50 VDC** to prevent permanent damage. Use the Open Circuit (Voc) to make sure the voltage does not exceed this value when connecting panels together in series.

- 
- The charge controller should be installed indoors in a well-ventilated, cool, and dry environment.
  - Do NOT allow water to enter the controller.

## ■ Battery Safety

- Do NOT let the positive (+) and negative (-) terminals of the battery touch each other.
- Use only sealed lead-acid, flooded, gel or lithium batteries which must be deep cycle.
- Explosive battery gases may be present while charging. Be certain there is enough ventilation to release the gases.
- Be careful when working with large lead acid batteries. Wear eye protection and have fresh water available in case there is contact with the battery acid.
- Over-charging and excessive gas precipitation may damage the battery plates and activate material shedding on them. Too high of an equalizing charge or too long of one may cause damage. Please carefully review the specific requirements of the battery used in the system.
- Equalization is carried out only for non-sealed / vented / flooded / wet cell lead acid batteries.
- Do NOT equalize VRLA type AGM / GEL / LITHIUM batteries UNLESS permitted by battery manufacturer.

# Table of Contents

General Information .....	04
Product Overview .....	05
Identification of Parts .....	05
Dimensions .....	06
Optional Components .....	06
Installation .....	07
Mounting Recommendations .....	07
Wiring and Fusing .....	08
Operation .....	14
Auto Recognition .....	14
Main Display .....	14
LCD Overview .....	15
MPPT Technology .....	16
Settings .....	18
Set the Battery type .....	18
Load Terminal .....	20
Troubleshooting .....	22
Error Codes .....	22
Maintenance .....	24
Technical Specifications .....	25

## General Information

The Wanderer is an advanced charge controller for off-grid solar applications. Integrating highly efficient PWM charging, this controller increases battery life and improves system performance. It can be used for 12V/24V battery banks. The controller is embedded with self-diagnostics and electronic protection functions that prevent damages from installation mistakes or system faults.

### ■ Key Features

- Automatic Voltage Detection for 12V/24V Non-Lithium Systems and Lithium Battery Activation
- Preset for Deep Cycle Sealed, Gel, Flooded Batteries and Lithium-iron Phosphate Batteries
- 4-Stage PWM Charging: Bulk, Boost, Float, and Equalization
- Back-lit LCD for displaying system operation, diverse load control, and error codes if any
- Integrated 5V, up to 2.1Amp USB for mobile or portable device charging
- Protection Against: overcharging, over-current, short circuit, reverse polarity
- Bluetooth Monitoring Ready port with addition of BT-1 Module and Renogy DC Home App

# Product Overview

## ■ Identification of Parts



## Key Parts

- ① LCD Screen
- ② Select Button
- ③ Enter Button
- ④ USB Ports
- ⑤ Load Terminals
- ⑥ Battery Terminals
- ⑦ PV Terminals
- ⑧ RS232 Communication Port

## ■ Dimensions

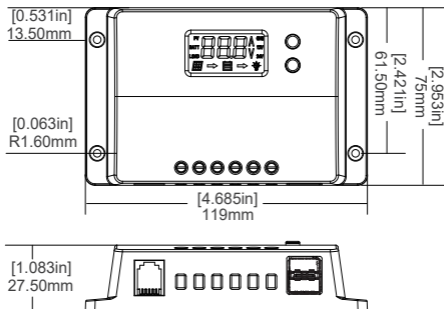

**NOTE**

The dimensions have a  $\pm 0.5\text{mm}$  tolerance

## ■ Optional Components

### Renogy BT-1 Bluetooth Module (Model: RCM-BT1)



The RCM-BT1 is a great addition to Renogy charge controllers with an RS232 port. Pair the controller using the BT-1 Module and the Renogy DC Home App to monitor your system using a smart phone or tablet. Read or set parameters to monitor your system in real time!

# Installation

## WARNING

Connect the battery to the charge controller BEFORE connecting the solar panel(s) unless you have the solar suitcase with controller exception. The controller needs a stable power source to operate.

## CAUTION

Do not over-torque or over tighten the screw terminals. This could potentially break the piece that holds the wire to the charge controller.

Refer to the technical specifications for max wire sizes on the controller and for the maximum amperage going through wires.

## ■ Mounting Recommendations

### WARNING

Never install the controller in a sealed enclosure with flooded batteries. Gas can accumulate and there is a risk of explosion.

- 1. Choose Mounting Location**—place the controller on a vertical surface protected from direct sunlight, high temperatures, and water. Make sure there is good ventilation.
- 2. Check for Clearance**—verify that there is sufficient room to run wires, as well as clearance above and below the controller for ventilation. The clearance should be at least 6 inches (150mm).
- 3. Mark Holes**
- 4. Drill Holes**
- 5. Secure the charge controller.**

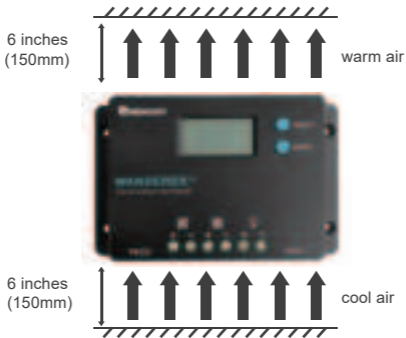



## ■ Wiring and Fusing

**NOTE**

The wire terminals are closed by default.

Use bare wiring when connecting to the Wanderer's terminal blocks. Due to default positioning, you must ensure that the terminal hatch is completely open before the first-time use.

1. Make sure to rotate the hatch counterclockwise (CCW) into the open position to expose the wire hatch
2. Insert bare wire into the terminal for the respective connection
3. Rotate clockwise (CW) until the hatch has closed and clamped onto the wire

Open Terminal Block	Closed Terminal Block
	

Depending on the PV Array wiring and battery size, the recommended fuse and cable gauge will depend on the actual amps flowing through the cable. The following chart accounts for less than 3% voltage drop and may not account for all configurations.

Battery Voltage	PV Watts	Battery Cable Recommended	Max Terminal Size
12V	130W	12 AWG	12 AWG
24V	260W		

Battery Voltage	PV Input Amps	0 ~ 10ft / 0 ~ 3m	11 ~ 20ft / 3m ~ 6m	21 ~ 30ft / 6m ~ 9m
12V	100W ~ 5A	16 AWG	16 ~ 14AWG	14 ~ 12AWG
24V	2x100W~5A*	16 AWG	16 ~ 14AWG	14 ~ 12AWG

\*Panel connection assumes series to meet 24V system minimum setup.

Larger wire sizes generally improve performance, whereas smaller wire sizes may reduce performance, especially if undersized. When considering wiring, fusing, and connection options, think big and short as possible as heavier components and shorter wire length offer less resistance and voltage drop. Terminal Size Limitations may apply.

Fusing is a recommendation in PV systems to provide a safety measure for connections going from panel to controller and controller to battery. Remember to always use the recommended wire gauge size based on the PV system and the controller.

<b>NEC Maximum Current for different Copper Wire Sizes</b>									
<b>AWG</b>	<b>16</b>	<b>14</b>	<b>12</b>	<b>10</b>	<b>8</b>	<b>6</b>	<b>4</b>	<b>2</b>	<b>0</b>
<b>Max. Current</b>	10A	15A	20A	30A	55A	75A	95A	130A	170A

#### **Fuse from Controller to Battery**

**Controller to Battery Fuse =  
Current Rating of Charge Controller**

**Ex. Wanderer 10 = 10A fuse from Controller to Battery**

#### **Fuse from Solar Panel(s) to Controller**

**Ex. 200W; 2 X 100 W panels**

**Parallel**

**Total Amperage =  $I_{sc1} + I_{sc2} = (5.75A + 5.75A) * 1.2$**

**Fuse = minimum of  $11.5 * 1.2 = 14.38 = 15A$  fuse**

## ■ Battery Wiring

**WARNING**

Connect the battery to the charge controller BEFORE connecting the solar panel(s) unless you have the solar suitcase with controller exception. The controller needs a stable power source to operate.

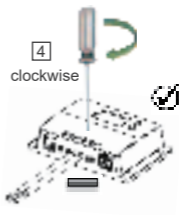
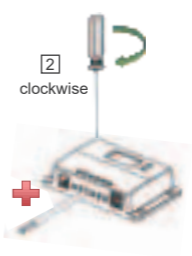

## ■ PV Wiring

1  
counterclockwise

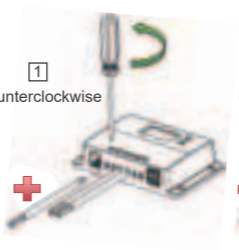

2  
clockwise

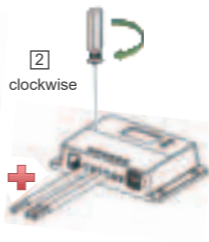

3  
counterclockwise

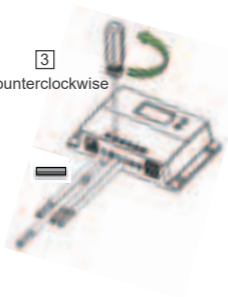

4  
clockwise

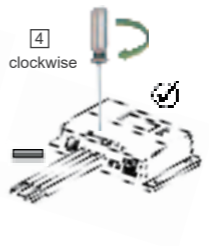

## ■ Load Wiring (Optional)

1  
counterclockwise



2  
clockwise



3  
counterclockwise

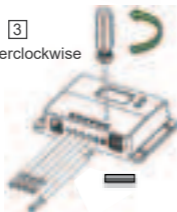

4  
clockwise

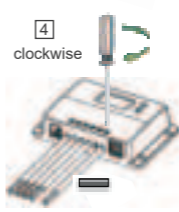

## ■ Communication Wiring (Optional)

1



2



## Operation

After connecting the battery to the charge controller, the controller will turn on automatically. Assuming normal operation, the charge controller will cycle through different displays. The user can adjust some parameters based on the display screen. The user can manually cycle through the display screens by using the "SELECT" and "ENTER" buttons.

● <b>SELECT</b>	Tap—Cycles Forward through the LCD screens
● <b>ENTER</b>	Tap—Cycle Backward through the LCD Screens Tap—Turns on Load Circuit in Manual Load Mode Long Press—Hold to enter Setting Mode

### ■ Auto Recognition

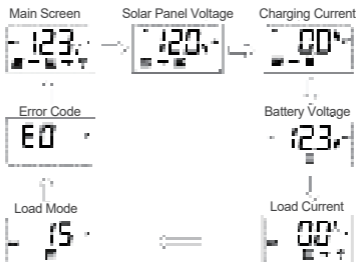

The Wanderer controller will be able to automatically detect the battery voltage for Non-Lithium 12V or 24V batteries. Lithium batteries need to be manually programmed and can be found in Settings.

### ■ Main Display

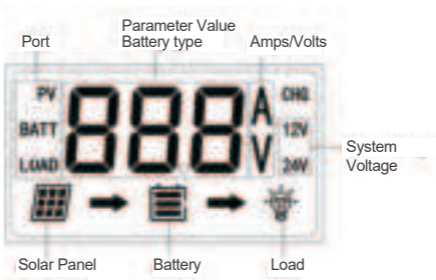

## ■ LCD Overview



Icon or Value	State	Description
 →	Steady on	Solar Panels Charging Battery
	3 Bars Flashing	Battery Voltage (16.1V+)
	3 Bars	Battery Voltage (12.9V- 16.0V)
	2 Bars	Battery Voltage (12.5-12.8V)
	1 Bar	Battery Voltage (11.6-12.4V)
	No Bars	Battery Voltage (11.5V and below)
	No Bars Flashing	Battery Voltage (10.9V and below)
→ 	Steady on	Load is On

# PMM Technology

## ■ PWM Technology

The Wanderer utilizes Pulse Width Modulation (PWM) technology for battery charging. Battery charging is a current based process so controlling the current will control the battery voltage. For the most accurate return of capacity, and for the prevention of excessive gassing pressure, the battery is required to be controlled by specified voltage regulation set points for Absorption, Float, and Equalization charging stages. The charge controller uses automatic duty cycle conversion, creating pulses of current to charge the battery.

The duty cycle is proportional to the difference between the sensed battery voltage and the specified voltage regulation set point. Once the battery reached the specified voltage range, pulse current charging mode allows the battery to react and allows for an acceptable rate of charge for the battery level.

## ■ Four Charging Stages

The Wanderer has a 4-stage battery charging algorithm for a rapid, efficient, and safe battery charging. They include: Bulk Charge, Boost Charge, Float Charge, and Equalization.

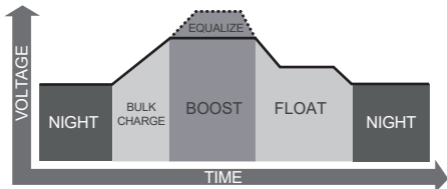

---

**Bulk Charge:** This algorithm is used for day to day charging. It uses 100% of available solar power to recharge the battery and is equivalent to constant current.

**Boost Charge:** When the battery has charged to the Boost voltage set-point, it undergoes an absorption stage which is equivalent to constant voltage regulation to prevent heating and excessive gassing in the battery. The Boost time is 120 minutes.

**Float Charge:** After Boost Charge, the controller will reduce the battery voltage to a float voltage set point. Once the battery is fully charged, there will be no more chemical reactions and all the charge current would turn into heat or gas. Because of this, the charge controller will reduce the voltage charge to smaller quantity, while lightly charging the battery. The purpose for this is to offset the power consumption while maintaining a full battery storage capacity.

In the event that a load drawn from the battery exceeds the charge current, the controller will no longer be able to maintain the battery to a Float set point and the controller will end the float charge stage and refer back to bulk charging.

**Equalization:** Is carried out every 28 days of the month. It is intentional overcharging of the battery for a controlled period. Certain types of batteries benefit from periodic equalizing charge, which can stir the electrolyte, balance battery voltage and complete chemical reaction. Equalizing charge increases the battery voltage, higher than the standard complement voltage, which gasifies the battery electrolyte.

**WARNING**

Once equalization is active in the battery charging, it will not exit this stage unless there is adequate charging current from the solar panel. There should be NO load on the batteries when in equalization charging stage.

---

Over-charging and excessive gas precipitation may damage the battery plates and activate material shedding on them. Too high of equalizing charge or for too long may cause damage. Please carefully review the specific requirements of the battery used in the system.

### **Lithium Battery Activation**

The Wanderer PWM charge controller has a reactivation feature to awaken a sleeping lithium battery. The protection circuit of Li-ion battery will typically turn the battery off and make it unusable if over-discharged. This can happen when storing a Li-ion pack in a discharged state for any length of time as self-discharge would gradually deplete the remaining charge. Without the wake-up feature to activate and charge batteries, these batteries would become unserviceable and the packs would be discarded. The Wanderer will apply a small charge current to activate the protection circuit and if a correct cell voltage can be reached, it starts a normal charge.

## **Settings**

At minimum you should set the battery type and voltage to ensure your system's livelihood.

### **■ Set the Battery type**

#### **Non-Lithium**

Set the battery type by maneuvering to the Battery Voltage Screen where it should demonstrate the battery icon and voltage.

- 1.Highlight Battery Voltage Screen
- 2.Hold ENTER for approximately 3s until the battery type starts to flash
- 3.Tap SELECT to highlight your desired battery
- 4.To confirm, hold ENTER for 3s to select the battery

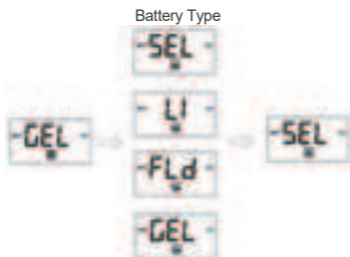

## Lithium

Press SELECT until you highlight the Battery Voltage Screen where it should demonstrate the battery icon and voltage.

- 1.Highlight Battery Voltage Screen
- 2.Hold ENTER for approximately 3s until the battery type starts to flash
- 3.Tap SELECT to highlight Lithium battery, Tap ENTER to confirm Lithium
- 4.Tap SELECT to highlight nominal battery voltage as 12V or 24V, Tap Enter to confirm
- 5.Tap Select to choose your charging voltage setpoint, voltages are in 0.2V increments
- 6.To confirm, hold ENTER for 3s to confirm Lithium, Battery Voltage, and Charge Voltage

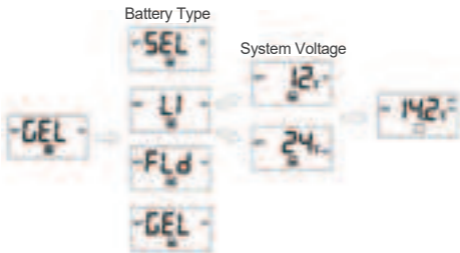

## ■ Load Terminal

### WARNING

Make sure the load is compatible with the battery type of the system. 12V loads damaged in 24V battery systems will not be covered in warranty.

The Load Terminal allows you to connect DC devices directly to the controller with timer functions as optional features. The Load Terminal is an extension of your battery charging circuit so the voltages on your battery will be present in the Load terminal since it is powered by the battery. This means that when charging a 12V bank, those charging voltages will also be seen in the Load Terminal. The terminal limits are set by the controller, so no more than 10Amps. In addition, when connecting to a 24V battery bank, you will also have a 24V DC Load Terminal that you can also utilize. Stick with simple electronics such as lights, fans, that have no issues turning on/off at any time.

### Programming the Load Terminal



Press SELECT until you highlight the Load Mode Screen where it should demonstrate a numerical load mode. The following chart indicates numbers representing hours ON that the load terminal

Setting	Mode	Description
0	Automatic (On/Off)	The load will turn on at night when the solar panel is no longer producing any power after a short time delay. The load will turn off when the panel starts producing power.
1-14	Time control	When the panel is no longer producing power, the load will be ON for 1-14 hours or until the panel starts producing power.
15	Manual	In this mode, the user can turn the Load On/Off by pressing the Enter button at any time.
16	Test	Used to troubleshoot load terminal (No Time Delay). When voltage is detected load will be off and when no voltage is detected load will be on.
17	24Hr	The load will be on for 24 hours a day.

- 1.Highlight Load Mode Screen
- 2.Hold ENTER for approximately 3s until the Load Mode starts to flash
- 3.Tap SELECT to highlight your desired Load Mode
- 4.To confirm, hold ENTER for 3s to select your Load Mode

Programs 0, 1-14, 16, and 17 are automatic processes that operate from the PV detection circuit as soon as they are set. No other action is necessary. Program 15 requires manual user toggling so users will need to press ENTER on the Main Screen or Load Mode Screen to observe the Light Bulb Brightness icon being activated to confirm Load also being activated.

# Troubleshooting

## ■ Error Codes

If the Rover is not functioning correctly, it may be undergoing an internal electronic protection and sharing an error message. The error messages stop normal operation and clear when resolved. This is not indicative of a defective controller but may require some troubleshooting to resume normal operation.

Error Code	Meaning	Troubleshoot
E0	No Error	System behaving normally, no action needed. You will not see this error code.
E01	Over-discharged battery	Use a multi-meter to get a reading of the battery voltage in volts DC to validate error code. Battery is very low. Disconnect any loads to the battery and let the solar system charge the battery backup. If the battery voltage is low it may be in open battery protection mode, which is a Wanderer Protection.
E02	Battery Over-charging	Use a multi-meter to get a reading of the battery voltage in volts DC to validate error code. Battery is charging very high and approached 16VDC. Disconnect any external chargers and isolate which charger is overcharging battery. Eliminate from system.
E04	Load Short Circuit	The load terminals have made contact or there is an internal short affecting the circuitry. Disconnect any loads and use a multi-meter to measure the voltage to at the load terminal to make sure it matches the battery voltage. Double check the load mode. Disconnect the controller from the battery and restart.

Error Code	Meaning	Troubleshoot
E05	Load Overloaded	Load has exceeded 10Amps DC. Connect simple electronics to the load terminal and do not connect devices such as inverters, battery chargers, or other high amp devices. Disconnect your load, double check the rating, and double check the correct Load Mode is on. Disconnect the controller from the battery and restart.
E06	Controller internals over temperature	Make sure controller is in ventilated area and that the appropriate wire sizes are used to connect to and from the controller. This may be creating heating issues inside the controller. The controller will resume normal operation upon cooling down.
E08	PV Input Overcurrent	Double check your connections and make sure the short circuit current of your panels do not exceed 10amps.
E10	PV Over-voltage	The controller has a maximum dc voltage input of 50VDC. If connecting your panels in series, make sure the reading does not go over this limit. Check with a multi-meter before connecting to the controller to ensure you're within this specification. This might require using less panels.
E13	PV reverse-polarity	The solar panel wires are connected in reverse polarity. Verify using a multi-meter to make sure your voltage reading has the correct polarity with a positive number in volts DC.

Error Code	Meaning	Troubleshoot
E14	Battery reverse polarity	The battery cables are reversed. Use a multi-meter to make sure your voltage reading has the correct polarity (Red to positive and Black to negative) with a positive number in volts DC. If the number is negative, switch the positive and negative battery cables in the battery terminal of the Wanderer.

## Maintenance

**WARNING**

Risk of Electric Shock! Make sure that all power is turned off before touching the terminals on the charge controller.

For best controller performance, it is recommended that these tasks be performed from time to time.

- Check that controller is mounted in a clean, dry, and ventilated area.
- Check wiring going into the charge controller and make sure there is no wire damage or wear.
- Tighten all terminals and inspect any loose, broken, or burnt up connections.
- Check to make sure none of the terminals have any corrosion, insulation damage, high temperature, or any burnt/discoloration marks.



## Technical Specifications

Description	Parameter
Nominal Voltage	12V/24V Auto Recognition
Rated Charge Current	10A
Max. PV Input Voltage	55 VDC
USB Output	5V, 2A max
Self-consumption	≤10mA
Operating Temperature	-25 °C to +45 °C   -31 °F to 113 °F
Storage Temperature	-35 °C to +80 °C   -31 °F to 176 °F
Enclosure	IP20
Terminals	Up to #12 AWG
Weight	0.27 lbs.
Dimensions	4.68 x 2.95 x 1.08 inches
Communication	RS232
Battery Type	Sealed (AGM), Gel, Flooded and Lithium

## Battery Charging Parameters



All the coefficient is referred to 25°C



Battery	GEL	SLD/AGM	FLOODED	LI (LFP)
High Voltage Disconnect	16 V	16 V	16 V	16 V
Over-voltage Reconnect	15 V	15 V	15 V	15 V
Equalization Voltage	----	----	14.6 V	----
Boost Voltage	14.2 V	14.6 V	14.6 V	14.2 V (USER: 12V-16V)
Float Voltage	13.8 V	13.8 V	13.8 V	----
Boost Return Voltage	13.2 V	13.2 V	13.2 V	13.2 V
Low Voltage Reconnect	12.6 V	12.6 V	12.6 V	12.6 V
Discharging Limit Voltage	10.8 V	10.8 V	10.8 V	10.8 V
Equalization Duration	----	----	2 hours	----
Boost Duration	2 hours	2 hours	2 hours	----

**US** |  2775 E Philadelphia St, Ontario, CA 91761, USA  
 909-287-7111  
 [www.renogy.com](http://www.renogy.com)  
 [support@renogy.com](mailto:support@renogy.com)

**CN** |  苏州高新区科技城培源路1号5号楼-4  
 400-6636-695  
 <https://www.renogy.cn>  
 [support@renogy.cn](mailto:support@renogy.cn)

**JP** |  <https://www.renogy.jp>  
 [supportjp@renogy.com](mailto:supportjp@renogy.com)

**CA** |  <https://ca.renogy.com>  
 [supportca@renogy.com](mailto:supportca@renogy.com)

**AU** |  <https://au.renogy.com>  
 [supportau@renogy.com](mailto:supportau@renogy.com)

**UK** |  <https://uk.renogy.com>  
 [supportuk@renogy.com](mailto:supportuk@renogy.com)

**DE** |  <https://de.renogy.com>  
 [supportde@renogy.com](mailto:supportde@renogy.com)