

**Maintenance Manual**

# **VectorStar<sup>®</sup>**

## **ME7828A**

**Broadband and Millimeter-Wave Vector Network Analyzer System**  
**70 kHz to 110 GHz**

The Anritsu logo consists of the word "Anritsu" in a bold, sans-serif font. The letter "A" is stylized with a diagonal slash through it.



## Notes On Export Management

This product and its manuals may require an Export License or approval by the government of the product country of origin for re-export from your country.

Before you export this product or any of its manuals, please contact Anritsu Company to confirm whether or not these items are export-controlled.

When disposing of export-controlled items, the products and manuals need to be broken or shredded to such a degree that they cannot be unlawfully used for military purposes.

## CE Conformity Marking

Anritsu affixes the CE Conformity marking onto its conforming products in accordance with Council Directives of The Council Of The European Communities in order to indicate that these products conform to the EMC and LVD directive of the European Union (EU).



## C-tick Conformity Marking

Anritsu affixes the C-tick marking onto its conforming products in accordance with the electromagnetic compliance regulations of Australia and New Zealand in order to indicate that these products conform to the EMC regulations of Australia and New Zealand.



## Mercury Notification

This product uses an LCD backlight lamp that contains mercury. Disposal may be regulated due to environmental considerations. Please contact your local authorities or, within the United States, the Electronics Industries Alliance ([www.eiae.org](http://www.eiae.org)) for disposal or recycling information.

# European Parliament and Council Directive 2002/96/EC

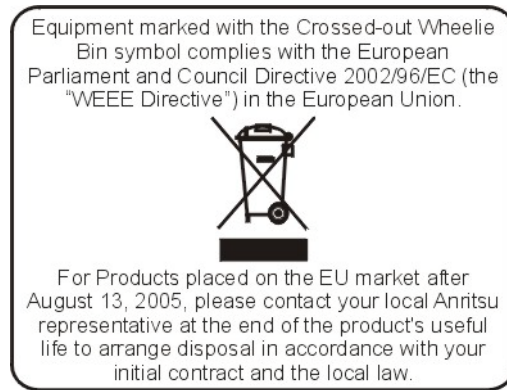

## Chinese RoHS Compliance Statement

产品中有毒有害物质或元素的名称及含量

For Chinese Customers Only YLNB

部件名称	有毒有害物质或元素					
	铅 (Pb)	汞 (Hg)	镉 (Cd)	六价铬 [Cr(VI)]	多溴联苯 (PBB)	多溴二苯醚 (PBDE)
印刷线路板 (PCA)	×	○	×	×	○	○
机壳、支架 (Chassis)	×	○	×	×	○	○
LCD	×	×	×	×	○	○
其他 (电缆、风扇、连接器等) (Appended goods)	×	○	×	×	○	○

○：表示该有毒有害物质在该部件所有均质材料中的含量均在 SJ/T11363-2006 标准规定的限量要求以下。  
 ×：表示该有毒有害物质至少在该部件的某一均质材料中的含量超出 SJ/T11363-2006 标准规定的限量要求。

### 环保使用期限

 这个标记是根据 2006/2/28 公布的「电子信息产品污染控制管理办法」以及 SJ/T 11364-2006 「电子信息产品污染控制标识要求」的规定，适用于在中国销售的电子信息产品的环保使用期限。仅限于在遵守该产品的安全规范及使用注意事项的基础上，从生产日起算的该年限内，不会因产品所含有害物质的泄漏或突发性变异，而对环境污染，人身及财产产生深刻地影响。  
 注) 生产日期标于产品序号的前四码 (如 S/N 0728XXXX 为 07 年第 28 周生产)。

## Safety Symbols

To prevent the risk of personal injury or loss related to equipment malfunction, Anritsu Company uses the following symbols to indicate safety-related information. For your own safety, please read the information carefully *before* operating the equipment.

### Symbols Used in Manuals

#### Danger



This indicates a risk from a very dangerous condition or procedure that could result in serious injury or death and possible loss related to equipment malfunction. Follow all precautions and procedures to minimize this risk.

#### Warning



This indicates a risk from a hazardous condition or procedure that could result in light-to-severe injury or loss related to equipment malfunction. Follow all precautions and procedures to minimize this risk.

#### Caution



This indicates a risk from a hazardous procedure that could result in loss related to equipment malfunction. Follow all precautions and procedures to minimize this risk.

### Safety Symbols Used on Equipment and in Manuals

The following safety symbols are used inside or on the equipment near operation locations to provide information about safety items and operation precautions. Ensure that you clearly understand the meanings of the symbols and take the necessary precautions *before* operating the equipment. Some or all of the following five symbols may or may not be used on all Anritsu equipment. In addition, there may be other labels attached to products that are not shown in the diagrams in this manual.



This indicates a prohibited operation. The prohibited operation is indicated symbolically in or near the barred circle.



This indicates a compulsory safety precaution. The required operation is indicated symbolically in or near the circle.



This indicates a warning or caution. The contents are indicated symbolically in or near the triangle.



This indicates a note. The contents are described in the box.



These indicate that the marked part should be recycled.

## For Safety

### Warning



Always refer to the operation manual when working near locations at which the alert mark, shown on the left, is attached. If the operation, etc., is performed without heeding the advice in the operation manual, there is a risk of personal injury. In addition, the equipment performance may be reduced.

Moreover, this alert mark is sometimes used with other marks and descriptions indicating other dangers.

### Warning



or

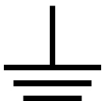

When supplying power to this equipment, connect the accessory 3-pin power cord to a 3-pin grounded power outlet. If a grounded 3-pin outlet is not available, use a conversion adapter and ground the green wire, or connect the frame ground on the rear panel of the equipment to ground. If power is supplied without grounding the equipment, there is a risk of receiving a severe or fatal electric shock.

### Warning



This equipment can not be repaired by the operator. Do not attempt to remove the equipment covers or to disassemble internal components. Only qualified service technicians with a knowledge of electrical fire and shock hazards should service this equipment. There are high-voltage parts in this equipment presenting a risk of severe injury or fatal electric shock to untrained personnel. In addition, there is a risk of damage to precision components.

### Warning



Use two or more people to lift and move this equipment, or use an equipment cart. There is a risk of back injury if this equipment is lifted by one person.

### Caution



Electrostatic Discharge (ESD) can damage the highly sensitive circuits in the instrument. ESD is most likely to occur as test devices are being connected to, or disconnected from, the instrument's front and rear panel ports and connectors. You can protect the instrument and test devices by wearing a static-discharge wristband. Alternatively, you can ground yourself to discharge any static charge by touching the outer chassis of the grounded instrument before touching the instrument's front and rear panel ports and connectors. Avoid touching the test port center conductors unless you are properly grounded and have eliminated the possibility of static discharge.

Repair of damage that is found to be caused by electrostatic discharge is not covered under warranty.

# Table of Contents

---

## Chapter 1—General Information

1-2	Identification Number . . . . .	1-1
1-3	Related Manuals and Documentation. . . . .	1-1
1-4	ME7828A VNA System Overview. . . . .	1-2
	ME7828A Broadband System Configurations. . . . .	1-2
	ME7828A Millimeter-Wave System Configuration. . . . .	1-3
1-5	Anritsu Customer Service Centers . . . . .	1-4
1-6	Electrostatic Discharge (ESD) Prevention . . . . .	1-4
1-7	Recommended Test Equipment . . . . .	1-5

## Chapter 2—Replaceable Parts

2-2	Exchange Assembly Program . . . . .	2-1
2-3	ME7828A System Replaceable Parts. . . . .	2-2
2-4	3738A Test Set Replaceable Subassemblies and Parts . . . . .	2-3

## Chapter 3—Performance Verification

3-2	Calibration and Measurement Conditions. . . . .	3-1
	Standard Conditions . . . . .	3-1
3-3	System Verification – Broadband System Configuration . . . . .	3-2
	Performance Verification Software Overview . . . . .	3-2
	Verification Result Determination . . . . .	3-2
3-4	System Verification Procedure – Broadband System Configuration . . . . .	3-3
	Equipment Required . . . . .	3-3
	Special Precautions. . . . .	3-3
	Procedure . . . . .	3-3
3-5	System Operational Check – Millimeter-Wave System Configuration . . . . .	3-4
	Equipment Required . . . . .	3-4
3-6	System Operational Check – Millimeter-Wave System Configuration . . . . .	3-4
	Procedure . . . . .	3-4

## Chapter 4—Theory of Operation

4-2	System Overview . . . . .	4-1
4-3	Functional Description of Main Components . . . . .	4-3
	Vector Network Analyzer. . . . .	4-3
	Millimeter Test Set. . . . .	4-3
	Signal Generator . . . . .	4-3
	Millimeter-Wave Modules . . . . .	4-4
	Multiplexing Couplers . . . . .	4-5
4-4	System Operation . . . . .	4-6
	Broadband Operation for frequencies 67 GHz and below. . . . .	4-6
	Millimeter band Operation (Broadband Operation for frequencies above 67 GHz). . . . .	4-6

## Table of Contents (Continued)

---

### Chapter 5—Troubleshooting

5-2	General Safety Warnings .....	5-1
5-3	Troubleshooting Strategy .....	5-1
	Suggested Troubleshooting Steps .....	5-1
5-4	General Troubleshooting of the System .....	5-2
	Procedure .....	5-2
5-5	General Troubleshooting of the 3738A Test Set .....	5-3
	Suggested Troubleshooting Steps .....	5-3
5-6	Troubleshooting Test - Power Supply DC Check .....	5-3
	Equipment Required .....	5-3
	Procedure .....	5-3
5-7	Troubleshooting Test – Control PCB Signal Check .....	5-5
	Equipment Required .....	5-5
	Procedure .....	5-5
5-8	Troubleshooting Test – LO and RF Signal Check .....	5-7
	Equipment Required .....	5-7
	Procedure .....	5-7
5-9	Troubleshooting Test – IF Signal Check .....	5-8
	Equipment Required .....	5-8
	Procedure .....	5-8

### Chapter 6—Removal and Replacement Procedures

6-2	Tools Required .....	6-1
6-3	System Disassembly Procedure .....	6-1
6-4	Removing the Covers .....	6-2
	Procedure .....	6-3
6-5	Location of Major Components and Sub-assemblies .....	6-4
6-6	Power Supply – 40-130 .....	6-5
	Procedure .....	6-5
6-7	Control PCB Assembly – 54074-3 .....	6-6
	Procedure .....	6-6
6-8	LO Power Divider – 1091-87 .....	6-8
	Procedure .....	6-8
6-9	LO Isolator – 1000-49 .....	6-9
	Procedure .....	6-9
6-10	Transfer Switch – ND57971 .....	6-9
	Procedure .....	6-9
6-11	IF Amplifiers – 60-279 .....	6-11
	Procedure .....	6-11
6-12	IF Switches – 1020-44 .....	6-13
	Procedure .....	6-13
6-13	Rear Panel Fan Assembly - ND58282 .....	6-14
	Procedure .....	6-14



## Table of Contents (Continued)

---

6-14	Front Panel LED Cable Assembly - ND74548 .....	6-15
	Procedure .....	6-15

### **Appendix A—Test Records**

A-1	Introduction .....	A-1
A-2	ME7828A Millimeter-Wave Configuration VNA System Test Record .....	A-2
	Instrument Information .....	A-2
	Directivity .....	A-2
	Test Port Match .....	A-3

### **Appendix B—Specifications**

B-1	Technical Data Sheet .....	B-1
-----	----------------------------	-----

## Table of Contents (Continued)

---

# Chapter 1 — General Information

## 1-1 Introduction

This manual provides general service and maintenance instructions for Anritsu ME7828A Broadband / Millimeter-Wave Vector Network Analyzer Systems. It contains procedures for:

- Testing the system for proper operation
- Verifying System Performance, independent of any wafer-probe station
- Troubleshooting the failed system to the failed instrument/module level
- Locating and replacing failed parts in the system test set

Throughout this manual, the term “VNA System” will be used interchangeably to refer to the ME7828A Broadband / Millimeter-Wave Vector Network Analyzer System.

## 1-2 Identification Number

All Anritsu instruments are assigned an unique identification number (up to seven-digit), such as “090201” or “1010222”. This number appears on a decal affixed to the rear panel. Please use this identification number during any correspondence with Anritsu Customer Service about Anritsu instruments.

## 1-3 Related Manuals and Documentation

Manuals and Documentation related to the operation and maintenance of the ME7828A VNA Systems are listed in Table 1-1 and are typically available as a Portable Document Format (PDF) file which can be viewed using Acrobat Reader™, a free program that is available from Adobe System Incorporated (<http://www.adobe.com>).

For literature related to the Anritsu VectorStar® family of products, refer to:  
<http://www.anritsu.com/en-US/Products-Solutions/Products/MS4640A-Series.aspx>

**Table 1-1.** List of Related Manuals and Documentation

Title	Part Number
VectorStar MS4640A Series VNA Operation Manual	10410-00266
VectorStar MS4640A Series VNA Measurement Guide	10410-00269
VectorStar MS4640A Series VNA Maintenance Manual	10410-00268
VectorStar ME7828A Series Broadband/Millimeter-Wave VNA System Technical Data Sheet	11410-00452
VectorStar ME7828A Series Broadband/Millimeter-Wave VNA System Quick Start Guide	10410-00289
VectorStar ME7828A Series Broadband/Millimeter-Wave VNA System Installation Guide	10410-00287
MG3702xA RF/Microwave Signal Generator Operation Manual	10370-10370
MG3702xA RF/Microwave Signal Generator Maintenance Manual	10370-10372
3656B W1 Calibration/Verification Kit and 2300-496 System Performance Verification Software User Guide	10410-00286

## 1-4 ME7828A VNA System Overview

The Anritsu ME7828A VNA System can be configured as a Broadband VNA System or a Millimeter-Wave VNA System (Waveguide only).

### ME7828A Broadband System Configurations

The ME7828A Broadband VNA system provides single sweep coverage from 10 MHz to 110 GHz for measuring active devices. The system consists of the following items:

- MS4647A VectorStar VNA, 10 MHz to 70 GHz, with options 001, 007, 051
- 3738A Broadband VNA Test Set, with Option 002, ME7828A configuration
- MG37022A (2) Fast Switching Signal Generator, 2 to 20 GHz, with option 001
- 3742A-EW (2) Millimeter-Wave Module, 65 to 110 GHz, with Attenuator
- 66670-3 Left MUX Coupler, with 70 kHz Internal Bias Tee
- 66671-3 Right MUX Coupler, with 70 kHz Internal Bias Tee
- 806-206 (2) V Male to V Female Phase Stable Interconnect Cable, 24 inch
- 806-207 (2) V Male to V Male Phase Stable Interconnect Cable, 24 inch
- 3700C3 Floor Console

### ME7828A Broadband System Options

- MS4647A Option 070, 70 kHz Start Frequency
- MS4647A Option 002, Time Domain Measurements
- 70556 - Replaces 806-206 and 806-207 24 inch cables with 806-208 and 806-209 36 inch cables
- 70555 Cable set for SUSS MicroTec SIGMA integration
  - Replaces 806-206 and 806-207 24 inch cables with 806-210 and 806-211 14 inch cables
  - Replace RF and LO Ruggedized semi-rigid cables with 806-121 (2) 36 inch flex cables

### ME7828A – Option 012

Option 012 is a premium package offering enhanced performance of the ME7828A Broadband VNA System with single sweep coverage from 70 kHz to 110 GHz.

The package consists of the following additional items:

- MS4647A VectorStar VNA, Option 070, 70 kHz Start Frequency
- MS4647A VectorStar VNA, Option 062, Four Attenuators
- MS4647A VectorStar VNA, Option 002, Time Domain Measurements

## ME7828A Millimeter-Wave System Configuration

The ME7828A Millimeter-Wave VNA System provides waveguide band coverage up to 500 GHz. The system consists of the following items:

- Any MS464XA VectorStar VNA with the following requirements:
  - MS464XA-051, Option 051, Direct Access Loops
  - MS4640A-007, Option 007, Receiver Offset
  - MS4640A-001, Option 001, Rack Mount
- 3738A Test Set, with Option 002, ME7828A Configuration
- MG37022A (2) Fast Switching Signal Generator, 2 to 20 GHz, with option 001
- Any 3740A-x or 3741A-x Millimeter-Wave Modules (Two are required; one must be a 3740A-x)
- 3700C3 Floor Console

### Millimeter-Wave Module Options

The following Millimeter-Wave Modules are available for the ME7828A Millimeter-Wave VNA System. At least one pair of modules, matched for a waveguide band, are required. Multiple module pairs can be equipped with a single VNA system.

**Table 1-2.** Millimeter-Wave Modules

Band / Module Name	Frequency	Anritsu Model	Measurement Type
<b>V Band WR-15 mm-Wave Module</b>	50 to 75 GHz	3740-V, 2 each	Full 2-port measurements
		3740A-V	Forward measurements only
		3741A-V	Forward measurements only
<b>E Band WR-12 mm-Wave Module</b>	60 to 90 GHz	3740A-E, 2 each	Full 2-port measurements
		3740A-E	Forward measurements only
		3741A-E	Forward measurements only
<b>Extended E Band WR-12 mm-Wave Module</b>	56 to 94 GHz	3740A-EE, 2 each	Full 2-port measurements
		3740A-EE	Forward measurements only
		3741A-EE	Forward measurements only
<b>W Band WR-10 mm-Wave Module</b>	75 to 110 GHz	3740A-W, 2 each	Full 2-port measurements
		3740A-W	Forward measurements only
		3741A-W	Forward measurements only
<b>Extended W Band WR-10 mm-Wave Module</b>	65 to 110 GHz	3740A-EW, 2 each	Full 2-port measurements
		3740A-EW	Forward measurements only
		3741A-EW	Forward measurements only
		3742A-EW, 2 each	Full 2-port measurements

## 1-5 Anritsu Customer Service Centers

For the latest service and sales information in your area, please visit: <http://www.anritsu.com/Contact.asp>. Choose a country for regional contact information.

## 1-6 Electrostatic Discharge (ESD) Prevention

All electronic devices, components, and instruments can be damaged by electrostatic discharge. It is important to take preventative measures to protect the instrument and its internal subassemblies from electrostatic discharge.

An ESD safe work area and proper ESD handling procedures that conform to ANSI/ESD S20.20-1999 or ANSI/ESD S20.20-2007 is mandatory to avoid ESD damage when handling subassemblies or components found the 3738A test set.

Take steps to eliminate the static charges built-up on coaxial cables prior to connecting them to the VNA System test ports. This can be done by terminating one end of the cable with the short from the calibration kit and then grounding the outer conductor of the connector of the cables.

## 1-7 Recommended Test Equipment

Table 1-3 lists the recommended test equipment to be used for all maintenance activities for the ME7828A VNA System.

**Table 1-3.** Recommended Test Equipment for ME7828A VNA System

<b>INSTRUMENT</b>	<b>CRITICAL SPECIFICATION</b>	<b>RECOMMENDED MANUFACTURER/MODEL</b>	<b>USE*</b>
<b>Calibration/Verification Kit</b>	Connector Type: W1	Anritsu 3656B	BB, P
<b>PC Controller</b>	Configuration: Intel Pentium IV or later 1 GB RAM minimum Windows XP SP3 20 MB Hard-disk free space 1024 x 768 Display Resolution CD ROM Drive USB 2.0 Type A Port National Instruments GPIB Controller and Driver	Any	BB, P
<b>Calibration Kit</b>	Waveguide Flange: WR-10	Anritsu 3655W-1	mmW, P, T
<b>Waveguide Straight Section</b>	Waveguide Flange: WR-10	Maury Z106B	mmW, P
<b>Calibration Kit</b>	Waveguide Flange: WR-12	Anritsu 3655E-1	mmW, P, T
<b>Waveguide Straight Section</b>	Waveguide Flange: WR-12	Maury Y106B	mmW, P
<b>Calibration Kit</b>	Waveguide Flange: WR-15	Anritsu 3655V-1	mmW, P, T
<b>Waveguide Straight Section</b>	Waveguide Flange: WR-15	Maury V106B	mmW, P
<b>Spectrum Analyzer</b>	Frequency Range: 10 MHz to 20 GHz	Anritsu MS2719B	BB, mmW, T
<b>RF Cable</b>	Frequency Range: DC to 20 GHz Connector: K(m) to K(f)	Anritsu 15KKF50-1.5A	BB, mmW, T
<b>Adapter</b>	Connector: N(m) to K(m)	Anritsu 34NK50	BB, mmW, T
<b>Digital Multimeter</b>		Any	BB, mmW, T

\* USE CODES:

BB - Use with ME7828A Broadband System configuration

mmW - Use with ME7828A Millimeter-Wave System configuration

P - Use when doing system verification

T - Use when doing troubleshooting





# Chapter 2 — Replaceable Parts

## 2-1 Introduction

This chapter provides replaceable parts information for the following items:

- System level replaceable parts that are unique to ME7828A VNA System
- Replaceable parts in the ME7828A System Test Set, Model 3738A

Refer to the VectorStar MS4640A Series Maintenance Manual (part number: 10410-00268) for replaceable parts information for the MS4640A Series VNA.

Refer to the MG3702xA RF/Microwave Signal Generator Maintenance Manual (part number: 10370-10372) for replaceable parts information for the MG37022A Signal Generator.

## 2-2 Exchange Assembly Program

Anritsu maintains a module exchange program for selected subassemblies. If a malfunction occurs in one of these subassemblies, the defective item can be exchanged. Upon receiving your request, Anritsu will ship the exchange subassembly to you. You then have 45 days in which to return the defective item. All exchange subassemblies or RF assemblies are warranted for 90 days from the date of shipment, or for the balance of the original equipment warranty, whichever is longer.

Please have the exact model number and serial number of your equipment available when requesting this service as the information about your equipment is filed according to the instrument model and serial number. For more information about this program, contact your local Anritsu Service Center.

## 2-3 ME7828A System Replaceable Parts

Part numbers and descriptions of the ME7828A System level replaceable parts are shown in [Table 2-1](#).

**Note**

There are no serviceable components or subassemblies in the 3740A-x, 3741A-x, 3742A-EW Millimeter-Wave Modules or in the 66670-3 and 66671-3 Multiplexing Couplers. These items must be returned to Anritsu Customer Service for repair or replacement.

**Table 2-1.** ME7828A System Level Replaceable Parts list

Description	Part Number	Use
Ruggedized Cable, 3738A LO Input to Upper MG37022A RF Output	C34429-7	Standard
Ruggedized Cable, 3738A RF Input to Lower MG37022A RF Output	C34429-8	Standard
RF Cable, 36 inch, 3738A RF/LO Input to MG37022A RF Output – Two required per system	806-121	Optional
Interface Cable Set, 3738A to Millimeter-Wave Module – Two required per system	ND58268	Standard
RF Cable, 24 inch, VNA Px Source to Multiplexing Coupler Source – Two required per system	806-206	Standard
RF Cable, 24 inch, VNA bx In to Multiplexing Coupler b Out – Two required per system	806-207	Standard
RF Cable, 36 inch, VNA Px Source to Multiplexing Coupler Source – Two required per system	806-209	Optional
RF Cable, 36 inch, VNA bx In to Multiplexing Coupler b Out – Two required per system	806-208	Optional
RF Cable, 14 inch, VNA Px Source to Multiplexing Coupler Source – Two required per system	806-210	Optional
RF Cable, 14 inch, VNA bx In to Multiplexing Coupler b Out – Two required per system	806-211	Optional
GPIB Interface Cable, 2 meter – Two required per system	2100-2	Standard
Interface Cable Set, 3738A Rear Panel to MS4640A Rear Panel	ND70921	Standard
BNC male to BNC male cable – Six required per system	3-800-124	Standard
BNC Tee (female-male-female) – Three required per system	3-2600-2	Standard

## 2-4 3738A Test Set Replaceable Subassemblies and Parts

Part numbers and descriptions of the 3738A Test Set replaceable subassemblies are listed in [Table 2-2](#).

**Table 2-2.** 3738A Test Set Replaceable Subassemblies List

Description	Part Number
Power Supply	40-130
Fan Assembly	ND58282
IF Amplifier	60-279
IF Switch	1020-44
LO Isolator	1000-49
LO Power Divider	1091-87
Control PCB Assembly	57074-3
Transfer Switch	ND57971
Front Panel LED Cable Assembly	ND74548



# Chapter 3 — Performance Verification

## 3-1 Introduction

This chapter provides procedures to be used to verify the performance of the ME7828A VNA System in both Broadband system configuration and Millimeter-wave system configuration.

## 3-2 Calibration and Measurement Conditions

Extremes in the surrounding environmental conditions and the condition and stability of the calibration kits, coaxial test port connectors on the multiplexing couplers, waveguide interface of millimeter-wave modules, and interconnect coaxial cables linking the host VNA, test set, and millimeter-wave modules determine system measurement integrity to a large extent.

These are all user controlled conditions and, as such, should be evaluated periodically for impact on system performance. If these conditions vary significantly with time, the system verification procedures should be performed more often than the recommended annual cycle.

### Standard Conditions

The standard conditions specified below must be observed when performing any of the operations in this chapter - both during calibration and during measurement.

- Warm-up Time:
  - 90 minutes
- Environmental Conditions:
  - Temperature
    - $23\text{ }^{\circ}\text{C} \pm 3\text{ }^{\circ}\text{C}$ , with  $< 1\text{ }^{\circ}\text{C}$  variation from calibration temperature
  - Relative Humidity
    - 20-50% recommended

## 3-3 System Verification – Broadband System Configuration

The broadband system configuration verification procedures verify the measurement capability of the VNA, calibration kit, and any required adapters as a system by analyzing the measurement of artifacts that are traceable to national standards laboratories.

**Note** Anritsu does not support tests or verification processes for wafer probe equipment. Contact the vendor of the wafer probe equipment if such support is desired.

The procedures are automated by using the Anritsu 2300-496 Broadband VNA System Performance Verification Software in conjunction with the Anritsu 3656B Calibration / Verification Kit.

**Note** The use of a non-Anritsu calibration / verification kit is not supported.

### Performance Verification Software Overview

The Anritsu 2300-496 Broadband VNA System Performance Verification Software is provided on a PC-compatible CD-ROM disc packaged with the Anritsu 3656B Calibration / Verification Kit.

The System Performance Verification Software guides the user to do the following:

- Perform a low band, full 12-term SOLT calibration on the VNA system for frequencies up to 65 GHz using the 3656B Calibration / Verification Kit
- Perform a high band, full 12-term SSST calibration on the VNA system for frequencies above 65 GHz using the 3656B Calibration / Verification Kit
- Measure the S-parameters of the verification standards in the 3656B Calibration / Verification Kit
- Verify that the measured values are within the specified measurement uncertainty limits

### Verification Result Determination

The software verification process compares the measured S-parameter data of the standards against the original standard data for those devices that was obtained using the Factory Standard Broadband VNA System (at Anritsu). The Factory Standard VNA System is traceable through the Anritsu Calibration Laboratory's Impedance Standards. These standards are traceable to NIST through precision mechanical measurements and NIST approved impedance derivation methods.

The quality of the verification results is very dependent on the degree of care taken by the user in maintaining, calibrating, and using the system. The most critical factors are:

- The stability and quality of the devices in the calibration / verification kit
- The condition of the test port connector on the multiplexing couplers
- The pin depth of all connectors and the proper torquing of connections. These same factors also affect the VNA system's measurement quality

Consult the 3656B W1 Calibration / Verification Kit and the 2300-496 System Performance Verification Software User Guide – 10410-00286 – for proper use, care, and maintenance of the devices in the calibration / verification kit.

## 3-4 System Verification Procedure – Broadband System Configuration

The broadband system verification procedure is described below. The procedure assumes that the Broadband VNA System Performance Verification Software has been installed to an external personal computer with National Instruments GPIB interface running Microsoft® Windows® Operating System.

**Note**

The 3656B W1 Calibration / Verification Kit and 2300-496 System Performance Verification Software User Guide - 10410-00286 explains in details the personal computer requirements and procedures to be used for the installation and operation of the verification software on the personal computer.

### Equipment Required

- Personal Computer
  - Microsoft Windows Operating System
  - National Instruments GPIB interface and driver software
  - GPIB interface cable
- Anritsu 3656B W1 Connector Calibration / Verification Kit

### Special Precautions

When performing the procedures, observe the following precautions:

- Minimize vibration and movement of the system and attached components.
- Check pin depth and condition of connector for all adapters and calibration components. Clean the connector interface as needed.

### Procedure

1. Using the GPIB interface cable to connect the external computer to the MS4647A rear panel system GPIB connector (the upper GPIB port labeled **IEEE488.2 GPIB**).

**Note**

Do not connect the GPIB interface cable to the lower GPIB port labeled **Dedicated GPIB**.

2. Dismount both 3742A-EW Millimeter-Wave modules from the probe station, if required.

**Note**

Do not disconnect the multiplexing couplers from the millimeter-wave modules.

3. Place both modules on a leveled surface so that both test ports are facing each other.
4. Install the W1 female to female adapter from the 3656B Calibration / Verification Kit to Port 1 multiplexing coupler. This converts Port 1 from a male test port to a female test port.
5. Install the W1 male to female adapter from the 3656B Calibration / Verification Kit to Port 2 multiplexing coupler.
6. Run the Anritsu 2300-496 Broadband VNA System Performance Verification Software on the PC.
7. Follow the instructions displayed on the computer to perform the calibration.
8. Follow the instructions displayed on the computer to perform measurements of the verification standards.
9. If the verification fails, check the connectors of the test ports on the multiplexing couplers, calibration components, and the verification standards for damage, cleanliness, and proper connector and torquing. Also check the connections of the interconnect RF and IF coaxial cables and their phase stability. These are the most common causes for verification failures.

### 3-5 System Operational Check – Millimeter-Wave System Configuration

The millimeter-wave system configuration operational check procedure checks the calibrated system residual performance of the ME7828A System.

#### Equipment Required

- Anritsu 3655 Series Waveguide Calibration Kit
  - V Band (WR-15): 3655V-1
  - E Band (WR-12): 3655E-1
  - Extended E Band (WR-12): 3655E-1
  - W Band (WR-10): 3655W-1
  - Extended W Band (WR-10): 3655W-1
- Maury Microwave Waveguide Straight Section
  - V Band (WR-15): V106B
  - E Band (WR-12): Y106B
  - Extended E Band (WR-12): Y106B
  - W Band (WR-10): Z106B
  - Extended W Band (WR-10): Z106B

### 3-6 System Operational Check – Millimeter-Wave System Configuration

The millimeter-wave system operational check procedure is described below. It checks the corrected source match and corrected directivity of the ME7828A system at the test port of the millimeter-wave module. The system must be calibrated and the error correction must be applied for these tests.

#### Procedure

1. Ensure that the ME7828A system is assembled per the system assembly chapter of the VectorStar ME7828A Installation Guide, part number: 10410-00287.

**Note** Ensure that the power vernier knobs on the 3742A-EW modules is set fully clockwise for maximum test port output power.

**Note** Ensure that the associated precision straight waveguide section supplied with the millimeter-wave module is installed on the module. If the straight section is missing, install the straight waveguide section from the calibration kit. The precision straight section must be used to ensure good connection repeatability and good calibration quality.

2. Apply AC power to the System Console.
3. Refer to the VectorStar ME7828A Installation Guide, part number: 10410-00287, for instructions on setting up the GPIB addresses of both MG37022A Signal Generators.

**Note** 3738A Test Set and MG37022A Signal Generators must be powered on first. Allow the MG37022A Signal Generators to complete the bootup process prior to powering on the MS464XA VNA.

4. Allow the ME7828A System to warm up for at least 90 minutes.
5. On the MS4640A VNA, set the **start** and **stop** frequency to match operating frequency range of the millimeter-wave modules installed to the VNA system. For example, set the **start** frequency to 75 GHz and the **stop** frequency to 110 GHz if 3740A-W Modules are installed to the VNA system.
6. Set the # of Points to 401.



7. Press the **Avg** key and set the IFBW to 1 kHz.
8. Press the **Calibration** key.
9. Select Cal kit/AutoCal Characterization.
10. Insert the USB flash drive that contains the Calibration Kit Component Coefficients into one of the USB ports on the MS4640A front panel.
11. Select Install Kit/Charac.
12. In the Install window, select Cal Kit, and then click the **Browse** button.
13. In the Open window, click the Files of Type drop down arrow. Select **Lightning Files**.
14. Browse to the USB flash drive, select the `kit_info.wav` file, and then click the **Open** button to return to the Install window.
15. Select the **Open** button to install the coefficients.
16. Click **Back** on the lower section of the right side menu to return to previous menu.
17. Select **Calibrate | Manual Cal | 2-Port Cal | Modify Cal Setup | Line Type | Waveguide**
18. Select **Cal Method | Offset Short (SSLT)**
19. Select **Edit Cal Params**
20. In the Two Port Cal Setup window (see [Figure 3-1](#)), select:
  - a. Cal Type – Full 2 Port (or 1 Path 2 Port (1 → 2) if Port 2 module is a 3741A-x)
  - b. Load Type – Sliding Load

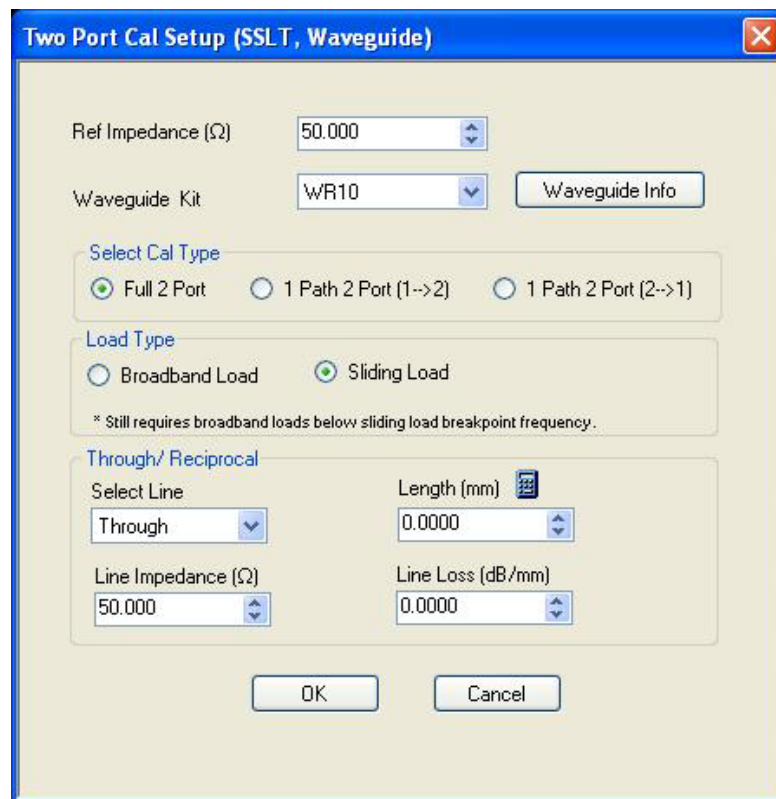

**Figure 3-1.** Two Port Cal Setup window

21. Click the **OK** button to close the window.
22. Click **Back** on the lower section of the right side menu to return to the previous menu.

23. Install the waveguide load from the 3655X Calibration Kit to the test port of Port 2 module.
24. Select Port 1 Reflective Devices.
25. Install the thinner shim and the short from the 3655X Calibration Kit to the test port of Port 1 module.
26. Select Short 1 to measure the calibration standard.
27. Remove the shim and the short from Port 1.
28. Install the thicker shim and the short to Port 1.
29. Select Short 2 to measure the calibration standard.
30. Remove the shim and the short from Port 1.
31. Install the waveguide load to Port 1.
32. Select Load to measure the calibration standard.
33. Remove the load from Port 1.
34. Select Sliding Load.
35. Set the vernier knob of the sliding load to 0 and install the sliding load to Port 1.
36. Select Position 1 to measure.
37. Adjust the vernier knob counter-clockwise for a few graduations.

<b>Note</b>	The vernier knob adjustment is not required to be precise. The requirement is to have five, non-equal distances for the next five positions when the sliding load is measured during calibration.
-------------	---

38. Select Position 2 to measure.
39. Adjust the vernier knob counter-clockwise to a new position.
40. Select Position 3 to measure.
41. Adjust the vernier knob counter-clockwise to a new position.
42. Select Position 4 to measure.
43. Adjust the vernier knob counter-clockwise to a new position.
44. Select Position 5 to measure.
45. Adjust the vernier knob counter-clockwise to a new position.
46. Select Position 6 to measure.
47. Click **Back** on the lower section of the right side menu to return to the previous menu.
48. For a Full 2-Port Cal Type, do the following:
  - a. Select Port 2 Reflective Devices.
  - b. Install the thinner shim and the short from the 3655X calibration kit to the test port of Port 2 module.
  - c. Select Short 1 to measure the calibration standard.
  - d. Remove the shim and the short from Port 2.
  - e. Install the thicker shim and the short to Port 2.
  - f. Select Short 2 to measure the calibration standard.
  - g. Remove the shim and the short from Port 2.
  - h. Install the waveguide load to Port 2.
  - i. Select Load to measure the calibration standard.
  - j. Remove the load from Port 2.

- k. Select Sliding Load.
- l. Set the vernier knob of the sliding load to 0 and install the sliding load to Port 2.
- m. Select Position 1 to measure.
- n. Adjust the vernier knob counter-clockwise for a few graduations.

**Note**

The vernier knob adjustment is not required to be precise. The requirement is to have five, non-equal distances for the next five positions when the sliding load is measured during calibration.

- o. Select Position 2 to measure.
  - p. Adjust the vernier knob counter-clockwise to a new position.
  - q. Select Position 3 to measure.
  - r. Adjust the vernier knob counter-clockwise to a new position.
  - s. Select Position 4 to measure.
  - t. Adjust the vernier knob counter-clockwise to a new position.
  - u. Select Position 5 to measure.
  - v. Adjust the vernier knob counter-clockwise to a new position.
  - w. Select Position 6 to measure.
  - x. Click Back on the lower section of the right side menu to return to the previous menu.
49. Remove the calibration standards from both test ports.
50. Connect the test ports of both modules together.
51. Select Thru/Recip | Thru 1-2.
52. Click Back on the lower section of the right side menu to return to previous menu.
53. Select Done to complete the calibration.
54. Separate the test ports.
55. Select Tr1 | Trace | Trace Max. The VNA should display the  $S_{11}$  measurement trace.
56. Select Display | Trace Format | Log Mag.
57. Connect the Maury Waveguide Straight Section to Port 1 and leave one end open.

**Note**

Ensure that the open end of the waveguide straight section is **not** facing any RF reflective surface.

58. Select Scale | Auto Scale Active Trace
59. Select Marker
60. Click Mkr 1, Mkr 2, and Mkr 3 to turn these markers On.

61. Using the mouse to move Mkr 1 and Mkr 2 to adjacent peaks of the ripple with the greatest negative trough (or adjacent troughs if the ripple has the greatest positive peak) in the frequency band of interest as shown in [Figure 3-2](#).

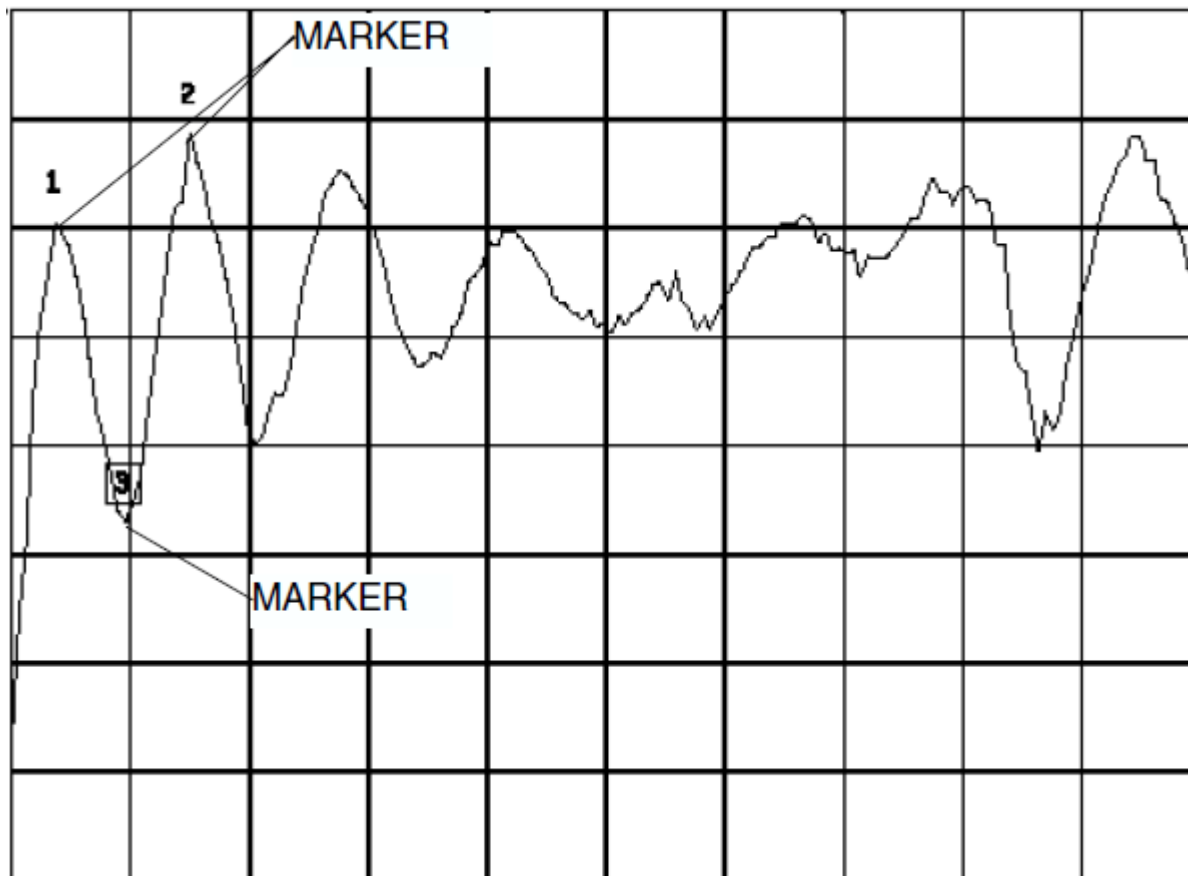

**Figure 3-2.** Markers Positioning

62. Position Mkr 3 to the bottom of the trough (or to the top of the peak if the ripple has the greatest position peak.)
63. Sum the magnitude values of Mkr 1 and Mkr 2 at the peaks (or troughs) and divide the result by two. This is the average value of the two peaks (or troughs). Refer to the example formula below:

$$\text{Average Value} = (\text{Mkr 1} + \text{Mkr 2})/2$$

Assuming Mkr 1 = -15.9634 dB and Mkr 2 = -15.641 dB, then

$$\text{Average Value} = (-15.9634 \text{ dB}) + (-15.641 \text{ dB})/2 = -15.8022 \text{ dB}$$

64. Calculate the peak-to-peak ripple value (absolute difference of the Mkr 3 value and the average value) as follows:

$$\text{dB}_{\text{p-p}} = |\text{Mkr 3 value} - \text{Average Value}|$$

Assuming Mkr 3 = -17.452 dB, then

$$\text{dB}_{\text{p-p}} = |-17.452 \text{ dB} - (-15.8022 \text{ dB})| = 1.6498 \text{ dB}$$

65. Use a RF measurement chart in [Figure 3-3 on page 3-9](#) to find the corresponding return loss value of the peak-to-peak ripple value.

The corresponding Return Loss value of 1.6498 dB<sub>p-p</sub> is approximately 20 dB

66. Also, find the corresponding Ref + X or Ref – X value from the RF measurement chart.

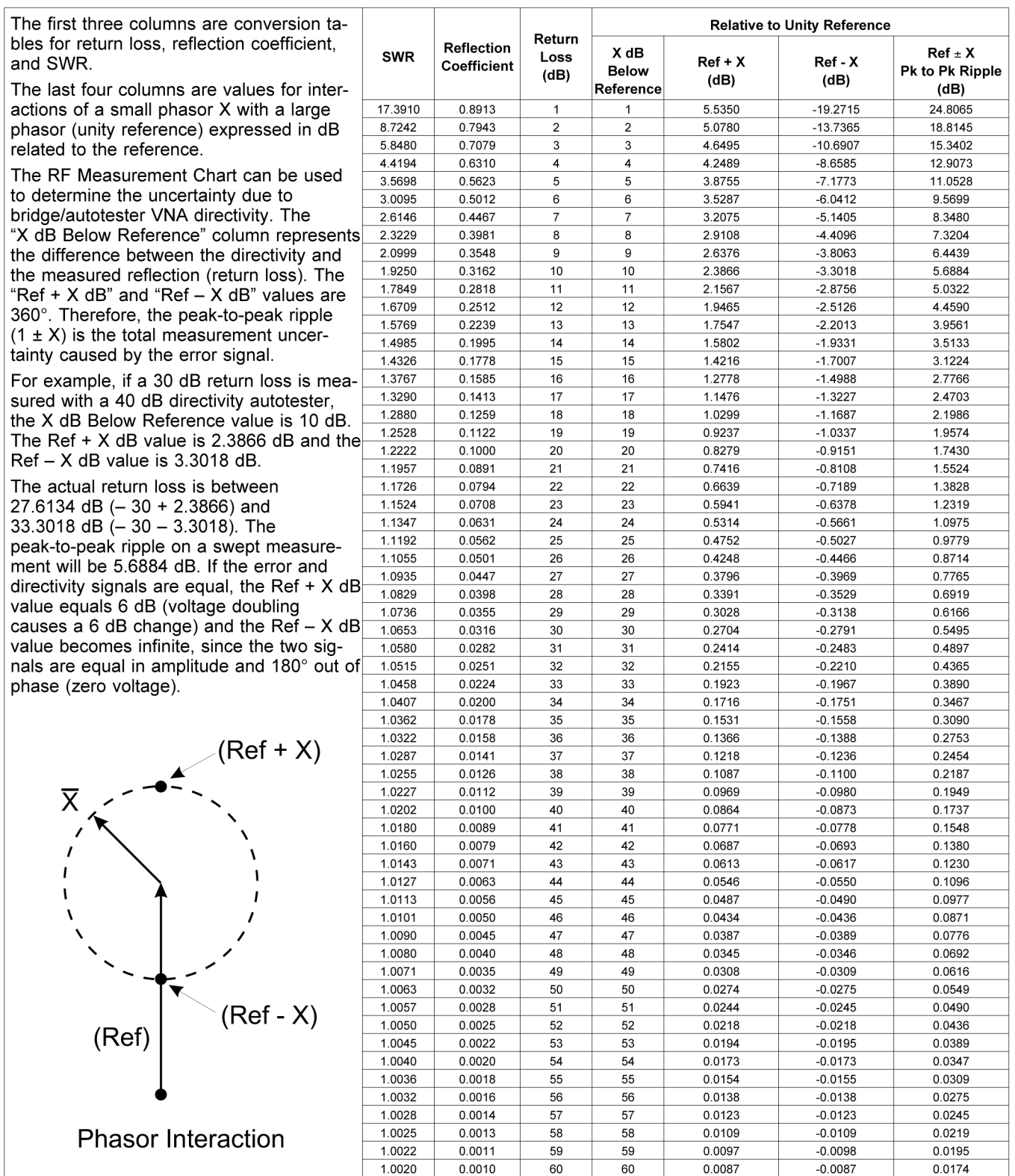

Figure 3-3. RF Measurement Chart

67. Use the following formula to calculate the directivity:

For ripple with a negative trough, Directivity = Return Loss value + |Mkr 3 value| – |Ref – X value|

For ripple with a positive peak, Directivity = Return Loss value + |Mkr 3 value| + |Ref + X value|

Example: Directivity = 20 dB + 17.452 dB - 0.9151 dB = 36.5369 dB

68. Record the directivity value into the Port 1 Measured column of [Table A-1, “Directivity” on page A-2](#).

69. Connect a short to the open end of the Maury Waveguide Straight Section.

70. Select Scale | Auto Scale Active Trace

71. Repeat Step 61 to Step 65.

72. Record the Return Loss value into Port 1 Measured column of [Table A-2, “Test Port Match” on page A-3](#).

73. Disconnect the short and the Maury waveguide section from the test port.

74. For 1 Path, 2 Port Cal Type, the procedure is complete.

75. For a Full 2 Port Cal Type, do the following:

- a. Select Trace | Trace Max | Trace Max | Trace Max. The VNA should now display the  $S_{22}$  measurement trace.
- b. Select Display | Trace Format | Log Mag.
- c. Connect the Maury Waveguide Straight Section to Port 2 and leave one end open.

<b>Note</b>	Ensure that the open end of the waveguide straight section is <b>not</b> facing any RF reflective surface.
-------------	--

d. Select Scale | Auto Scale Active Trace

e. Select Marker

f. Click Mkr 1, Mkr 2, and Mkr 3 to turn these markers On.

g. Repeat Step 61 to Step 67.

h. Record the directivity value into the Port 2 Measured column of [Table A-1, “Directivity” on page A-2](#).

i. Connect a short to the open end of the Maury Waveguide Straight Section.

j. Select Scale | Auto Scale Active Trace

k. Repeat Step 61 to Step 65.

l. Record the Return Loss value into Port 2 Measured column of [Table A-2, “Test Port Match” on page A-3](#).

m. Disconnect the short and the Maury Waveguide Straight Section from the test port.

# Chapter 4 — Theory of Operation

## 4-1 Introduction

This chapter provides a brief overview of the functional assemblies and major parts that comprise the ME7828A Broadband VNA System and ME7828A Millimeter-Wave VNA System. It also briefly describes the operation of each major assembly.

## 4-2 System Overview

ME7828A in either Broadband System configuration or Millimeter-Wave System configuration are ratio measurement system used to measure complex vector signal characteristics of devices and system up to 110 GHz.

The ME7828A VNA System performs complex vector measurements by sourcing a stimulus signal to the Device Under Test (DUT) that is connected to the test port connectors either on the Multiplexing Couplers or the Millimeter-Wave Modules. It simultaneously measures the DUT response, which consists of reflected and/or transmitted (attenuated or amplified) signals at the connectors of the DUT. The reflected/transmitted signals and a sample of the stimulus signal are down converted to intermediate frequency (IF) signals.

These IF signals are then converted into digital information and processed by a Digital Signal Processor (DSP) of the VNA to determine the real and imaginary vector components of the signal being measured. The information is then normalized for the desired S-parameter and presented to the user via the front panel color LCD display of the VNA.

The ME7828A VNA System consists of four main component groups:

- MS464XA Series VectorStar Vector Network Analyzer
- 3738A Millimeter Test Set
- Two MG37022A Fast Switching Microwave Signal Generators
- Two 374XA-X Series Millimeter-Wave Modules

The Broadband System configuration adds the following items:

- 66670-3 Multiplexing Coupler
- 66671-3 Multiplexing Coupler

The block diagram of ME7828A Broadband System configuration is shown in [Figure 4-1 on page 4-2](#).

The ME7828A Millimeter-Wave System configuration does not include the Multiplexing Couplers and their respective cables that connect between the VNA front panel connector and the Couplers.

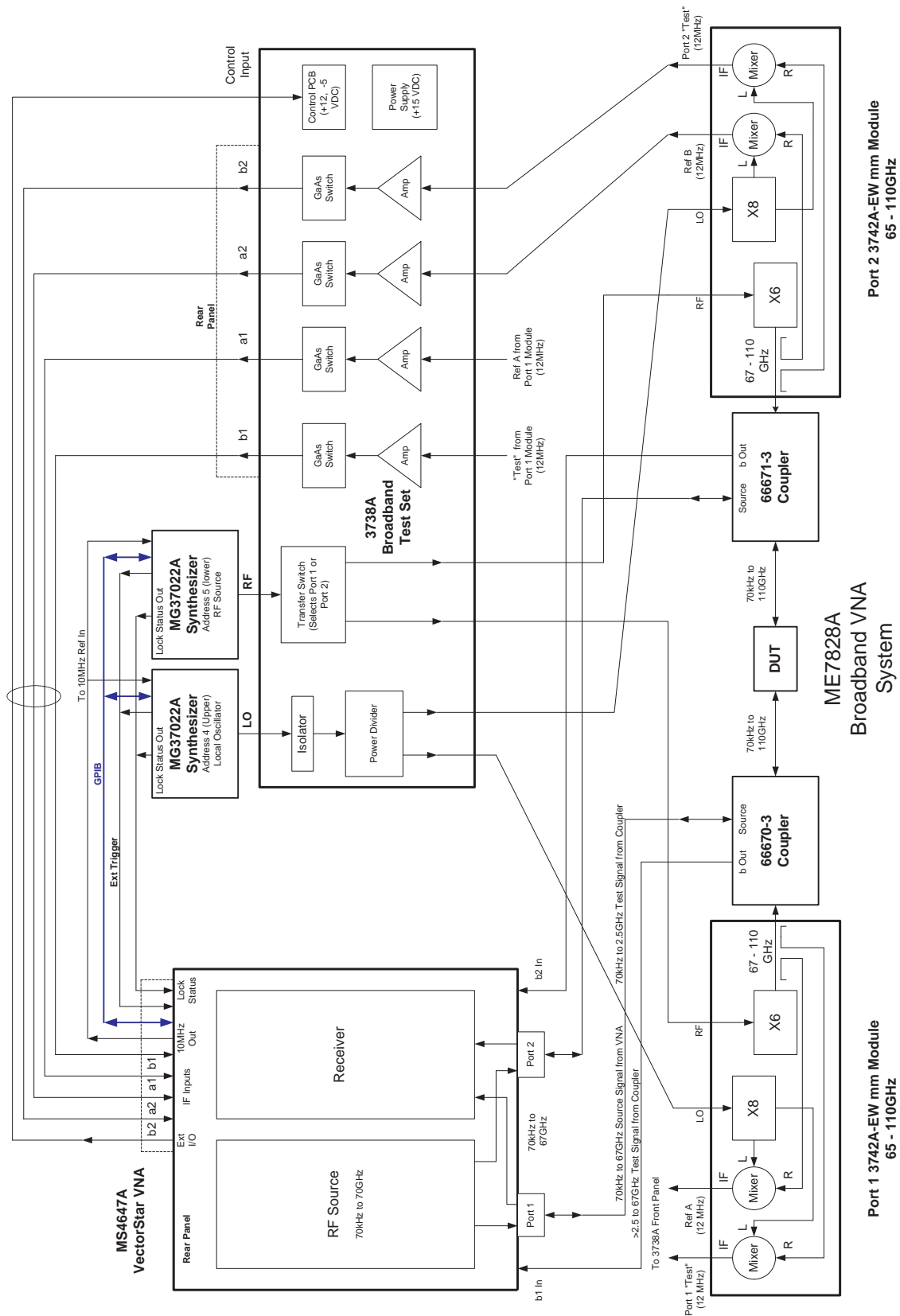

Figure 4-1. ME7828A Broadband System Configuration Block Diagram



## 4-3 Functional Description of Main Components

The section provides the functional description of the main components of the ME7828A VNA System.

### Vector Network Analyzer

For operation frequencies up to 67 GHz, the MS4647A Vector Network Analyzer provides the stimulus signal for the DUT. Its reflectometer components separate the test signals and its Digital Signal Processor processes the test signals (Reflected or Transmitted).

For operation frequencies above 67 GHz, the MS4647A VNA provides direct access to the four receiver samplers. The Reference IF and Test IF signals generated in the Millimeter-Wave modules are sent to the four input a1, b1, a2, b2 of the VNA via the Millimeter Test Set.

For Millimeter-Wave System configuration, any MS464XA VectorStar Vector Network Analyzer can be used.

### Millimeter Test Set

The 3738A Millimeter Test Set contains an LO signal Isolator, a LO signal Power Divider, a RF signal transfer switch, 4 sets of IF signal amplifiers, 4 sets of IF signal switches, a power supply and a Control PCB assembly.

The Control PCB assembly controls the RF signal transfer switch, IF switches and the front panel LEDs. It also has DC power conditioning circuitry for the internal IF amplifiers and the external Millimeter-Wave Module.

The Millimeter Test Set supplies the following DC bias to the external Millimeter-Wave Modules:

- +12V for RF IF Amplifier
- +15V for LO & Reference IF Amplifiers
- +15V for Test IF Amplifier

The Test Set is directly controlled by the VNA using TTL signals via the I/O port.

The LO input signal is routed through an isolator and then a power divider to the front panel Port 1 LO connector and Port 2 LO connector. The RF input signal is routed to the transfer switch. The VNA controls the transfer switch to route the RF signal to the appropriate front panel Port RF connector depending on the S-parameter being measured.

There are four separate IF paths in the 3738A. Each path is composed of an amplifier (gain is approximately 13 dB) and an IF switch. The signal through these paths is fixed at 270 MHz, which is the down-converted signal from the millimeter-wave modules.

Regardless of sweep direction, the IF switches and the IF amplifiers are biased ON (passing RF) when the system is operating with the millimeter-wave modules.

For ME7828A Broadband System configuration, the IF switches and IF amplifiers are biased OFF when the system frequency is below 67 GHz.

### Signal Generator

Two Anritsu model MG37022A Fast Switching Microwave Signal Generators are used in the ME7828A VNA system when operating above 67 GHz. They are controlled by the VNA via GPIB.

One MG37022A Signal Generator provides the LO drive signal for the millimeter-wave modules in the VNA system. It is used in 8 to 19 GHz frequency range and its power is set to +17 dBm.

The other MG37022A Signal Generator is used to provide the RF drive signal for the millimeter-wave modules in the VNA system. It is used in 9 to 19 GHz frequency range and its power is set to +13 dBm.

## Millimeter-Wave Modules

Two Anritsu Model 3742A-EW Millimeter-Wave Modules are used in the ME7828A Broadband System configuration.

At least one pair of modules, matched for a waveguide band, are required for the ME7828A Millimeter-Wave System configuration (e.g. 3740A-W/3740A-W or 3740A-W/3741A-W).

The millimeter-wave module contains the RF components to multiply the RF input to the desired test port frequency. It also contains a dual directional coupler needed to make transmission and reflection measurements. Harmonic mixers are used to convert the *reference* and *test* signals from the coupler to ~12 MHz Reference and Test IF signals that are sent to the VNA, via the millimeter test set. See [Figure 4-2, "Block Diagram of 3740A-X Transmission/Reflection Millimeter-Wave Module"](#).

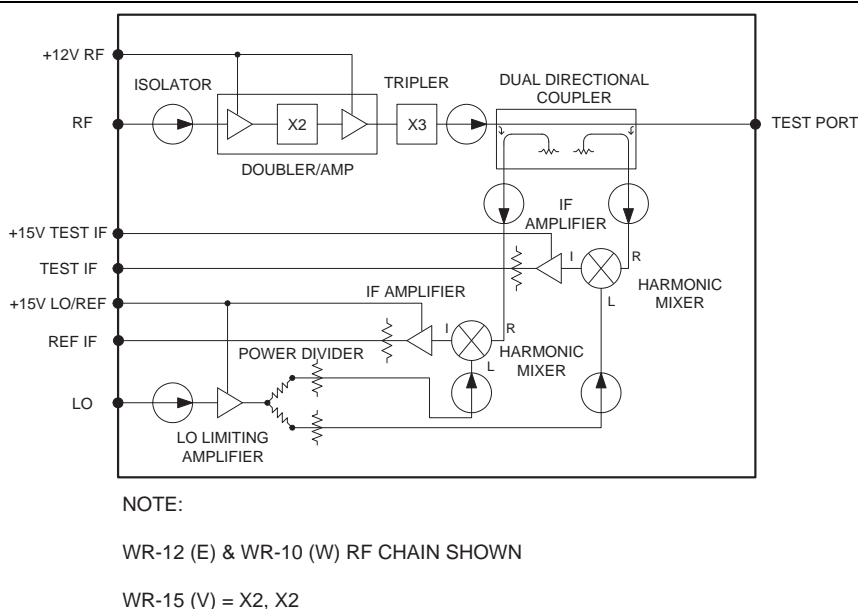
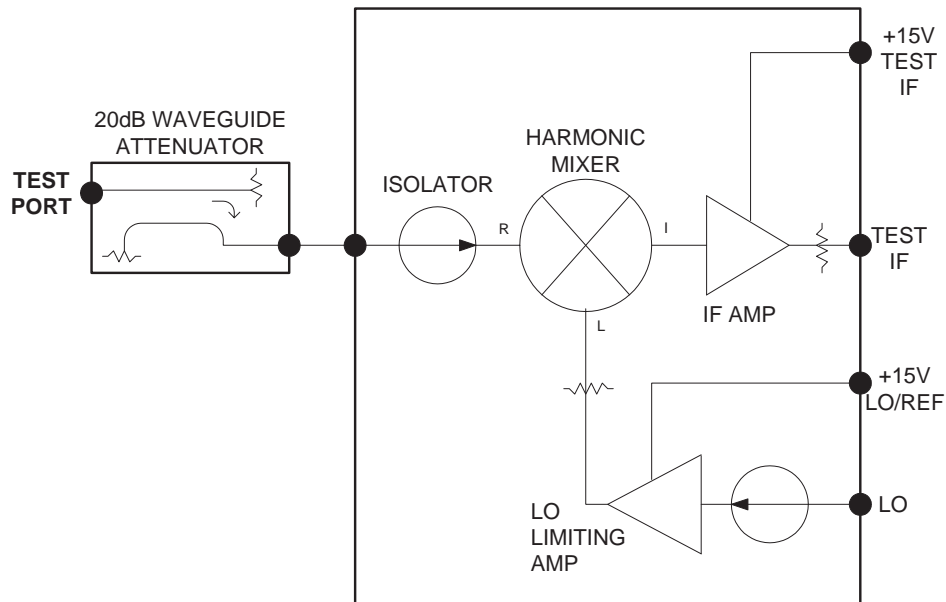

**Figure 4-2.** Block Diagram of 3740A-X Transmission/Reflection Millimeter-Wave Module

For E-band (WR-12) and W-band (WR-10) Modules, the X2 and X3 frequency multipliers are used. V-band modules (WR-15) use X2 and X2 frequency multipliers.

The 3742A-EW Module adds a 20 dB adjustable RF attenuator between the X3 frequency multiplier and the dual directional coupler.

The 3741A-X Module contains the harmonic mixer necessary to generate the Test IF signal. An external waveguide attenuator is used in conjunction with the 3741A-X to reduce the input signal so the harmonic mixer is not driven into compression. See [Figure 4-3, "Block Diagram of 3741A-X Transmission Module"](#).



**Figure 4-3.** Block Diagram of 3741A-X Transmission Module

## Multiplexing Couplers

Two multiplexing couplers are used in the broadband system configuration. The multiplexing coupler provides a test port with the W1 coaxial connector that operates to 110 GHz.

The coupler multiplexes the coaxial band signal of the VNA and millimeter band signal of the millimeter-wave modules to the W1 test port connectors and vice versa. It contains a directional coupler to separate the test signal from the stimulus signal for 67 GHz and below. The coupled arm of the directional coupler is fed to the b1 or b2 front panel receiver input. It also contains an internal Kevin Bias Tee for biasing active DUT.

## 4-4 System Operation

This section describes the operation of the ME7828A VNA System.

### Broadband Operation for frequencies 67 GHz and below

For frequencies 67 GHz and below, the VNA generates the stimulus signal and feeds it to the V connector input of the multiplexing coupler. The stimulus signal is then output through the W1 test port connector to the DUT. The reflected or transmitted test signal from the DUT is input through the W1 test port connector. The test signal is then fed to the VNA b1 or b2 front panel receiver input for further processing.

**Note**

For details about how the MS464XA VNA processes the test signal, refer to the Theory of Operation chapter in the MS464XA Maintenance Manual, part number: 10410-00268.

While the ME7828A VNA System is operating at frequencies 67 GHz and below, all the IF amplifiers and IF switches in the 3738A Test Set are turned off.

### Millimeter band Operation (Broadband Operation for frequencies above 67 GHz)

The following paragraphs describe the operation of a ME7828A VNA System using the Model 3742A-EW Modules.

During a typical measurement, the RF signal generator, under the direct control of the VNA, outputs a RF signal to the millimeter test set. This RF signal is one-sixth (1/6) of the desired device-under-test (DUT) frequency.

This RF signal is switched in the millimeter test set using the RF transfer switch and is sent to the millimeter-wave module through Port 1 or Port 2, depending on the S-parameter measured.

In the millimeter-wave module, the RF signal is doubled and amplified in the doubler/amplifier and then tripled in the tripler. The RF signal is then sent to the test port via the dual directional coupler. This is the stimulus signal for the DUT.

For broadband system configuration, the stimulus signal is fed to the waveguide input of the multiplexing coupler, which outputs the stimulus signal to the DUT through the W1 test port.

One coupled arm of the dual directional coupler provides the RF signal for the first harmonic mixer, generating the reference IF signal.

When there is any impedance mismatch between the test port and the DUT input port, some of the signal incident at the DUT input port is reflected back to the test port of the millimeter-wave module and some travels into the DUT. In the case of two port DUTs (that is those having an input and output port), the port of the stimulus signal that travels through the DUT goes to the test port of the second millimeter-wave module for measurement.

The reflected or transmitted test signal goes through the other coupled arm of the dual directional coupler and provides the test signal for the second harmonic mixer, generating the Test IF signal.

The LO signal generator, under the direct control of the VNA, outputs a LO signal to the millimeter test set. This signal is one-eighth (1/8) of the desired DUT frequency offset by 12 MHz. The LO signal enters the millimeter-wave module into a limiting amplifier, which is used to keep the LO power at a fixed level into the harmonic mixers. The LO signal is then split to provide inputs to both of the harmonic mixers.

The harmonic mixers, in the case of W-band, use the eighth harmonic of the LO signal. In the first harmonic mixer, the eighth harmonic of the LO is mixed with the coupled off RF signal to create the 12 MHz Reference IF input to the VNA. In the second harmonic mixer, the eighth harmonic of the LO is mixed with the RF signal reflected or transmitted from the DUT creating the 12 MHz Test IF.

The Reference IF signal is sent to a1 or a2 input of the VNA. The Test IF signal is sent to b1 or b2 input of the VNA. In the case of S11 forward reflection measurement, Reference IF signal and Test IF signal from the Port 1 module are sent to a1 and b1 inputs of the VNA respectively.

Each of these IF signals carries embedded magnitude and phase information relative to a reference signal. In the VNA, they are converted to digital data.

The digital signal processor of the VNA manipulates this digital data. Short-term system errors are normalized and digital compensation is generated and applied. The resultant S-parameter data characterizing the DUT is then presented on the VNA LCD display.



# Chapter 5 — Troubleshooting

## 5-1 Introduction

This chapter provides information about troubleshooting tests that can be used to check the ME7828A VNA System (both Broadband and Millimeter-Wave configurations) for proper operation. These tests are intended to be used as a troubleshooting tool for identifying the faulty system components and checking the functionality of internal components and sub-assemblies in the 3738A Test Set.

## 5-2 General Safety Warnings

Many of the troubleshooting procedures presented in this chapter require the removal of instrument covers to gain access to subassemblies and modules. When using these procedures, please observe the warning and caution notices.

<b>Warning</b>	Hazardous voltages are presented inside the instrument when AC line power is connected. Before removing any covers, turn off the instrument via the Main power switch on the front panel and unplug the AC power cord.
----------------	--

<b>Caution</b>	Many assemblies and modules in the 3738A contain static-sensitive components. Improper handling of these assemblies and modules may result in damage to the assemblies and modules. Always observe the static-sensitive component handling precautions.
----------------	---

## 5-3 Troubleshooting Strategy

The ME7828A VNA System consists of four main component groups:

- MS464XA Series VectorStar Vector Network Analyzer
- 3738A Millimeter Test Set
- Two MG37022A Fast Switching Microwave Signal Generators
- Two 374XA-X Series Millimeter-Wave Modules

The Broadband System configuration adds the following items:

- 66670-3 Multiplexing Coupler
- 66671-3 Multiplexing Coupler

A good understanding of the ME7828A VNA System operation is an important aid to troubleshoot system failures. Refer to the description of system operation, and block diagrams located in [Chapter 4, “Theory of Operation”](#)

### Suggested Troubleshooting Steps

The suggested troubleshooting steps for ME7828A VNA System are as follows:

- Ensure that both VNA and Test Set can be powered up.
- Ensure that no set-up and installation errors exist (for example: cabling errors and cable connections). Refer to the VectorStar ME7828A Series Broadband/Millimeter-Wave VNA System Installation Guide – part number 10410-00287.
- Isolate the fault to a system component (for example: VNA, Test Set, Millimeter-Wave Module, or Signal Source) using a process of elimination. Refer to [“General Troubleshooting of the System” on page 5-2](#).

<b>Note</b>	The critical information to know is the sweep direction and frequency at which the fault occurs.
-------------	--

## 5-4 General Troubleshooting of the System

This section provides general troubleshooting procedures of the ME7828A System. It assumes that setup and installation errors have been eliminated.

### Procedure

1. Set up the VNA to sweep the full frequency range of the ME7828A System (70 kHz to 110 GHz, 65 GHz to 110 GHz, etc.)
2. Set the VNA Display Trace 1 to  $S_{11}$ , and Trace 2 to  $S_{22}$ .
3. For ME7828A Broadband system configuration, disconnect both multiplexing couplers from both ports. Then install a short and an open to both VNA ports on the MS4640A.
4. Install flush waveguide shorts to both millimeter-wave modules.
5. Determine whether the fault occurs only in forward sweep ( $S_{11}$ ), only in reverse sweep ( $S_{22}$ ) or in both sweeps ( $S_{11}$ ,  $S_{22}$ ).
6. For ME7828A Broadband System configuration, determine whether the fault occurs only in the Coaxial band (<67 GHz) or the Millimeter-Wave band (>67 GHz).
  - a. If the fault occurs at any frequency below 67 GHz, you can assume that the fault lies in the MS4647A VNA. Refer to the VectorStar MS4640A Series VNA Maintenance Manual – Part Number 10410-00268 for troubleshooting information.
  - b. If the fault occurs at any frequency above 67 GHz, you can assume that the fault lies in the Millimeter-Wave band section of the VNA system.
7. For faults occurring in the ME7828A Millimeter-Wave band system configuration or in the Millimeter-Wave band (>67 GHz) of the ME7828A Broadband System configuration, observe the following:
  - a. If the fault occurs in only one sweep direction (forward –  $S_{11}$  or reverse –  $S_{22}$ ), you can eliminate both system sources as cause. The problem is in the millimeter-wave module or the 3738A Test Set or the rear panel IF input of the MS4640A VNA.
  - b. If you swap the millimeter-wave modules between Port 1 and Port 2, and the problem moves from Port 1 to Port 2, one of the millimeter-wave module is defective.
  - c. If you swap the millimeter-wave modules between Port 1 and Port 2, and the problem does not move, the failure is in the 3738A or the rear panel IF input of the MS4640A VNA.
  - d. If the fault occurs in both sweep directions, the problem can be in the System Sources or the 3738A Test Set.
  - e. Refer to [“General Troubleshooting of the 3738A Test Set” on page 5-3](#) for procedures to further isolate if the fault is in the 3738A Test Set.
8. If no faults are found in the steps above, then the problem is in one of the Multiplexing Couplers.



## 5-5 General Troubleshooting of the 3738A Test Set

This section provides general troubleshooting procedures of the 3738A Test Set.

### Suggested Troubleshooting Steps

The suggested troubleshooting steps for 3738A Test Set are as follows:

- Verify that the DC voltages from the power supply are at the expected level. Refer to [“Troubleshooting Test - Power Supply DC Check” on page 5-3](#).
- Verify that the Control PCB signals are at the expected level. Refer to [“Troubleshooting Test - Control PCB Signal Check” on page 5-5](#).
- Verify that the LO and RF signal levels are at the expected level. Refer to [“Troubleshooting Test - LO and RF Signal Check” on page 5-7](#).
- Verify that the IF Path signal levels are present. Refer to [“Troubleshooting Test - IF Signal Check” on page 5-8](#).

## 5-6 Troubleshooting Test - Power Supply DC Check

This procedure verifies that the expected DC voltages from the power supply is present.

### Equipment Required

- Digital Multimeter

### Procedure

1. Turn off the 3738A Test Set and unplug the AC power cord.
2. Remove the top cover of the 3738A Test Set.
3. Plug in the AC power cord, connect the Test Set to AC power and turn the unit back on.
4. Use a digital multimeter to measure the DC voltages at the test points stated in [Table 5-1, “Power Supply Expected DC Voltages” on page 5-3](#) on the 54074-3 Control PCB Assembly and verify if DC voltages are present and at the expected level. Refer to [Figure 5-1, “Control PCB Assembly Test Point Locations” on page 5-4](#) for test point locations.

**Table 5-1.** Power Supply Expected DC Voltages

Test Point	Common	Expected Voltage	Usage
TP3	TP8	+12V	IF Amp Bias
TP4	TP8	+5V	PCB Internal Circuits
TP5	TP8	+15V	From Power Supply
TP6	TP8	+5V	Not used
TP7	TP8	+12V	Fan Power
TP11	TP8	-5V	Not used

**Note** All DC supply voltages except the TP5 voltage are derived from voltage regulators on the 54074-3 PCB Assembly.

5. If TP5 has an incorrect voltage, replace the 40-130 power supply.
6. If other test points have incorrect voltages, replace the 54074-3 Control PCB Assembly.

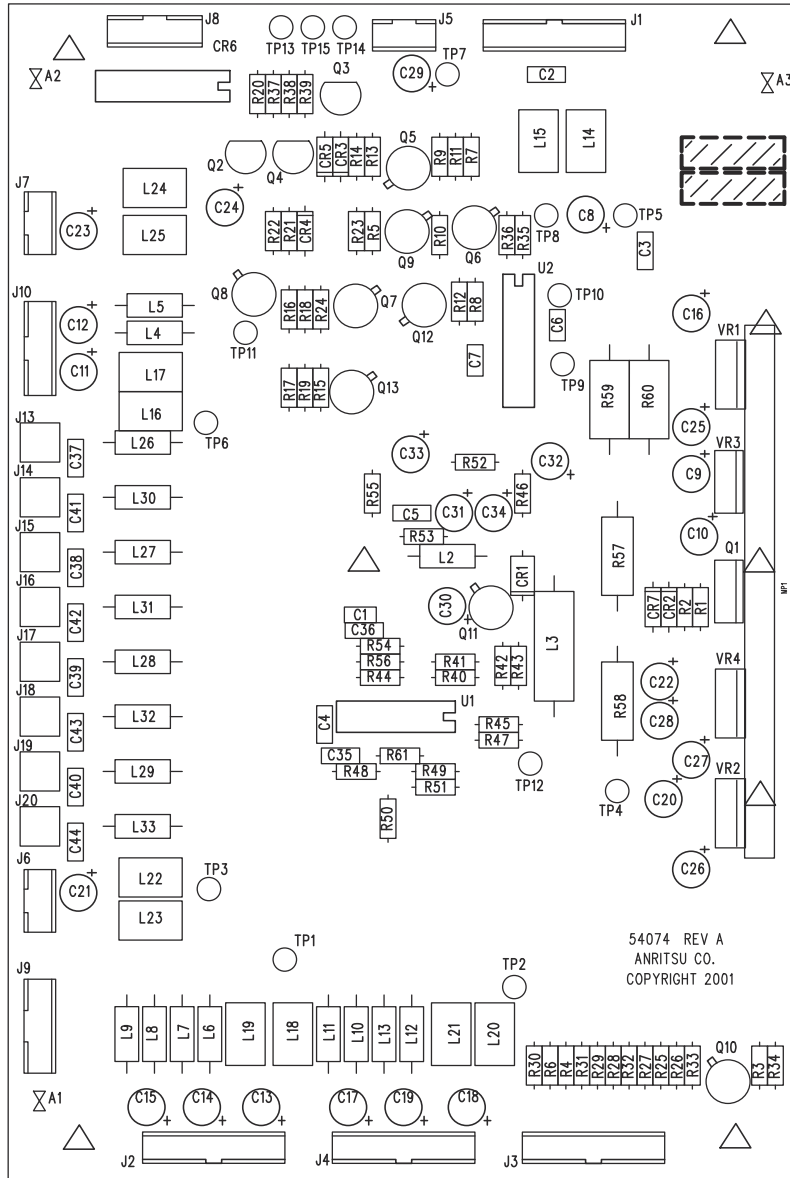

Figure 5-1. Control PCB Assembly Test Point Locations

## 5-7 Troubleshooting Test – Control PCB Signal Check

This procedure verifies that the expected signals are present at the 54074-3 Control PCB Assembly.

### Equipment Required

- Digital Multimeter

### Procedure

1. Turn off the 3738A Test Set and unplug the AC power cord.
2. Remove the top cover of the 3738A Test Set.
3. Plug in the AC power cord, connect the test set to AC power and turn the unit back on.
4. Ensure that the rear panel cable assemblies are installed between the MS4640A VNA and the test set.
5. Set the MS4640A VNA to display Tr1 S<sub>11</sub> only.
6. Use a digital multimeter to measure the signal at the test points stated in [Table 5-2, “Forward Sweep Control Signals” on page 5-5](#) on the 54074-3 Control PCB Assembly and verify if the signals are present and at the expected level. Be sure to use the sequence shown in the table when diagnosing and determining which part to replace. Refer to [Figure 5-1 on page 5-4](#) for test point locations.

**Table 5-2.** Forward Sweep Control Signals

Location	Signal Present	Actions if Control Signal is not present
TP14	TTL Low	Replace ND70921 VNA to Test Set interface cable
TP13	TTL Low	Replace ND70921 VNA to Test Set interface cable
TP9	~ -5V	Replace 54074-3 Control PCB
TP10	~ 0V	Replace 54074-3 Control PCB
Front Panel Port 1 Module LED	Lit*	Replace ND74548 Front Panel LED Cable Assembly
TP1	+12VDC	Replace 54074-3 Control PCB
TP2	0VDC	Replace 54074-3 Control PCB
J9 Pin 1	~ -3.8VDC	Replace 54074-3 Control PCB Replace Transfer Switch
J9 Pin 2	~ +2.2VDC	Replace 54074-3 Control PCB Replace Transfer Switch
Note	If the Front Panel Port 1 Module LED fails, the 54074-3 Control PCB will not operate properly in forward sweep.	

7. Change the MS4640A VNA Tr1 Display to S<sub>22</sub>.

8. Use a digital multimeter to measure the signal at the test points stated in [Table 5-3](#), “Reverse Sweep Control Signals” on [page 5-6](#) on the 54074-3 Control PCB Assembly, and verify if signals are present and at the expected level. Be sure to use the sequence shown in the table when diagnosing and determining which part to replace.

**Table 5-3.** Reverse Sweep Control Signals

Location	Signal Present	Actions if Control Signal is not present
TP14	TTL Low	Replace ND70921 VNA to Test Set interface cable
TP15	TTL Low	Replace ND70921 VNA to Test Set interface cable
TP9	~ -5V	Replace 54074-3 Control PCB
TP10	~ 0V	Replace 54074-3 Control PCB
Front Panel Port 2 Module LED	Lit*	Replace ND74548 Front Panel LED Cable Assembly
TP1	0VDC	Replace 54074-3 Control PCB
TP2	+12VDC	Replace 54074-3 Control PCB
J9 Pin 1	~ +2.2VDC	Replace 54074-3 Control PCB Replace Transfer Switch
J9 Pin 2	~ -3.8VDC	Replace 54074-3 Control PCB Replace Transfer Switch
Note	If the Front Panel Port 2 Module LED fails, the 54047-3 Control PCB will not operate properly in reverse sweep.	

## 5-8 Troubleshooting Test – LO and RF Signal Check

This procedure verifies that the expected LO and RF signals are present at the front panel connectors.

### Equipment Required

- Anritsu MS2719B Spectrum Analyzer
- Anritsu 15KKF50-1.5A K(m) to K(f) cable
- Anritsu 34NK50 N(m) to K(m) adapter

### Procedure

1. Ensure that the 3738A Test Set is installed in the 3700C3 Console and all cables are re-connected per the VectorStar ME7828A Series Broadband/Millimeter-Wave VNA System Installation Guide – part number 10410-00287.
2. Set up MS2719B Spectrum Analyzer to cover the 8 to 19 GHz frequency range. Install the 34NK50 adapter and 15KKF50-1.5A cable to the MS2719B input port.
3. Set the MS4640A display to Tr1 S<sub>11</sub> only.
4. Disconnect the Port 1 module LO cable from the 3738A front panel Port 1 LO output connector.
5. Connect the cable from the MS2719B to the 3738A Port 1 LO output connector.
6. Verify that the signal level being measured is approximately +11 dBm.
7. If the power level is low, replace the 1091-87 LO Power Divider.
8. Disconnect the spectrum analyzer cable and re-connect the Port 1 module LO cable.
9. Disconnect the Port 1 module RF cable from the 3738A Port 1 RF output connector.
10. Connect the cable from the MS2719B to the 3738A Port 1 RF output connector.
11. Verify that the signal level being measured is approximately +11 dBm.
12. If the power level is low, replace the ND57971 Transfer Switch.
13. Change the MS4640A Tr1 display to S<sub>22</sub> only.
14. Disconnect the Port 2 module LO cable from the 3738A front panel Port 2 LO output connector.
15. Connect the cable from the MS2719B to the 3738A Port 2 LO output connector.
16. Verify that the signal level being measured is approximately +11 dBm.
17. If the power level is low, replace the 1091-87 LO Power Divider.
18. Disconnect the spectrum analyzer cable and re-connect the Port 2 module LO cable.
19. Disconnect the Port 2 module RF cable from the 3738A Port 2 RF output connector.
20. Connect the cable from the MS2719B to the 3738A Port 2 RF output connector.
21. Verify that the signal level being measured is approximately +11 dBm.
22. If the power level is low, replace the ND57971 Transfer Switch.

## 5-9 Troubleshooting Test – IF Signal Check

This procedure verifies that the expected IF signals are present at the respective rear panel IF output of the 3738A Test Set.

### Equipment Required

- Anritsu MS2719B Spectrum Analyzer
- Anritsu 15KKF50-1.5A K(m) to K(f) cable
- Anritsu 34NK50 N(m) to K(m) adapter
- Anritsu 3655 Series Waveguide Calibration Kit
  - V Band (WR-15): 3655V-1
  - E Band (WR-12): 3655E-1
  - Extended E Band (WR-12): 3655E-1
  - W Band (WR-10): 3655W-1
  - Extended W Band (WR-10): 3655W-1

### Procedure

1. Ensure that the 3738A Test Set is installed in the 3700C3 Console and all cables are re-connected per the VectorStar ME7828A Series Broadband/Millimeter-Wave VNA System Installation Guide – part number 10410-00287.
2. Ensure that the millimeter-wave modules are working properly prior to doing the test. Refer to [Step 7 of “General Troubleshooting of the System” on page 5-2](#).
3. Install flush shorts to both millimeter-wave modules.
4. Set Center Frequency to 270 MHz and Span to 500 MHz on the MS2719B Spectrum Analyzer. Install the 34NK50 adapter and 15KKF50-1.5A cable to the MS2719B input port.
5. Set the MS4640A display Tr1 S<sub>11</sub> only.
6. Disconnect the a1 IF cable from the a1 IF out connector on the rear panel of the 3738A.
7. Connect the spectrum analyzer cable to the a1 IF out connector of the 3738A.
8. Verify that a 270 MHz signal is present.
9. If the signal is not present, replace the a1 IF switch and then the a1 IF amplifier.
10. Disconnect the b1 IF cable from the b1 IF out connector of the 3738A.
11. Connect the spectrum analyzer cable to the b1 IF out connector of the 3738A.
12. Verify that a 270 MHz signal is present.
13. If the signal is not present, replace the b1 IF switch and then the b1 IF amplifier.
14. Change the MS4640A Tr1 display to S<sub>22</sub> only.
15. Disconnect the a2 IF cable from the a2 IF out connector on the rear panel of the 3738A.
16. Connect the spectrum analyzer cable to the a2 IF out connector of the 3738A.
17. Verify that a 270 MHz signal is present.
18. If the signal is not present, replace the a2 IF switch and then the a2 IF amplifier.
19. Disconnect the b2 IF cable from the b2 IF out connector of the 3738A.
20. Connect the spectrum analyzer cable to the a2 IF out connector of the 3738A.
21. Verify that a 270 MHz signal is present.
22. If the signal is not present, replace the b2 IF switch and then the b2 IF amplifier.

# Chapter 6 — Removal and Replacement Procedures

## 6-1 Introduction

This chapter provides procedures for removing and re-installing the replaceable components and sub-assemblies in the 3738A Test Set.

## 6-2 Tools Required

All procedures in this chapter require the use of either a #1 or #2 size Phillips screwdriver. Most procedures require the use of a 5/16 inch wrench and the Anritsu 01-201 (8 lbf in) torque wrench. A soldering iron is required for replacing the IF Amplifier.

## 6-3 System Disassembly Procedure

Use this procedure to remove the 3738A Test Set from the 3700C3 System Console and prepare the Test Set for removal and replacement procedures for all of its replaceable components.

1. Prepare a clean and static free work area. Make sure that the work area is well grounded. Cover the work surface with a soft, clean anti-static mat.
2. Provide all personnel with appropriate anti-static grounding wrist straps and similar equipment.
3. Power off the MS4640A VNA.
4. Power off the 3738A Test Set
5. Power off both system sources.
6. Disconnect the millimeter-wave modules with their respective interface cables from the 3738A Test Set. Set the modules aside in a secure, clean, and anti-static environment.
7. Disconnect the LO and RF cables between system sources and the 3738A Test Set.
8. Disconnect the rear panel cables between the VNA and the test set. Disconnect the power cords from the AC power outlets.
9. Remove the 3738A Test Set from the 3700C3 System Console.
10. Move the 3738A Test Set to the repair area.

## 6-4 Removing the Covers

The following procedure describes the process of removing the external covers. The 3738A Test Set is assumed to be already removed from the 3700C3 System Console per “[System Disassembly Procedure](#)” on page 6-1.

**Note** Refer to [Figure 6-1](#), “[Removing the Covers](#)” below during this procedure.

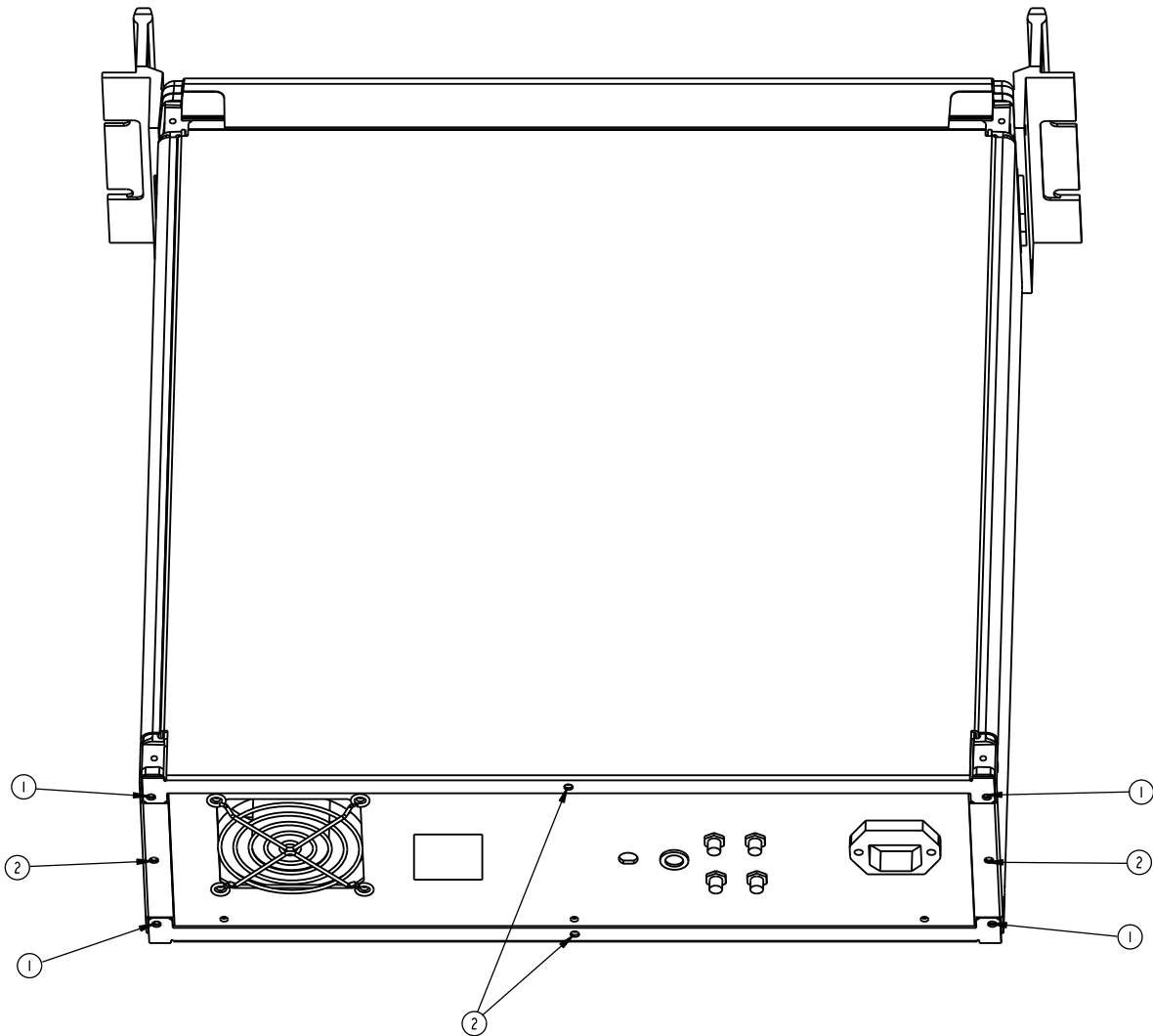

**Figure 6-1.** Removing the Covers



**Procedure**

1. To remove the top cover:
  - a. Place the test set in normal (top-side up) position.
  - b. Remove the two top corner screws (1) from the rear of the top cover.
  - c. Remove the center screw (2) from the rear of the top cover.
  - d. Lift and slide the top cover away from the test set.
2. To remove the bottom cover:
  - a. Place the test set on its top (bottom-side up) position.
  - b. Remove the two bottom corner screws (1) from the rear of the bottom cover.
  - c. Remove the center screw (2) from the rear of the bottom cover.
  - d. Lift and slide the bottom cover away from the test set.
3. To remove the right cover:
  - a. Place the test set on its left side.
  - b. Remove the center screw (2) from the rear of the right cover.
  - c. Lift and slide the right cover away from the test set.
4. To remove the left cover:
  - a. Place the test set on its right side.
  - b. Remove the center screw (2) from the rear of the left cover.
  - c. Lift and slide the left cover away from the test set.
5. To re-install the instrument covers, perform the previous steps in the reverse order.

## 6-5 Location of Major Components and Sub-assemblies

Figure 6-2 below shows the location of major components and sub-assemblies in the 3738A Test Set.

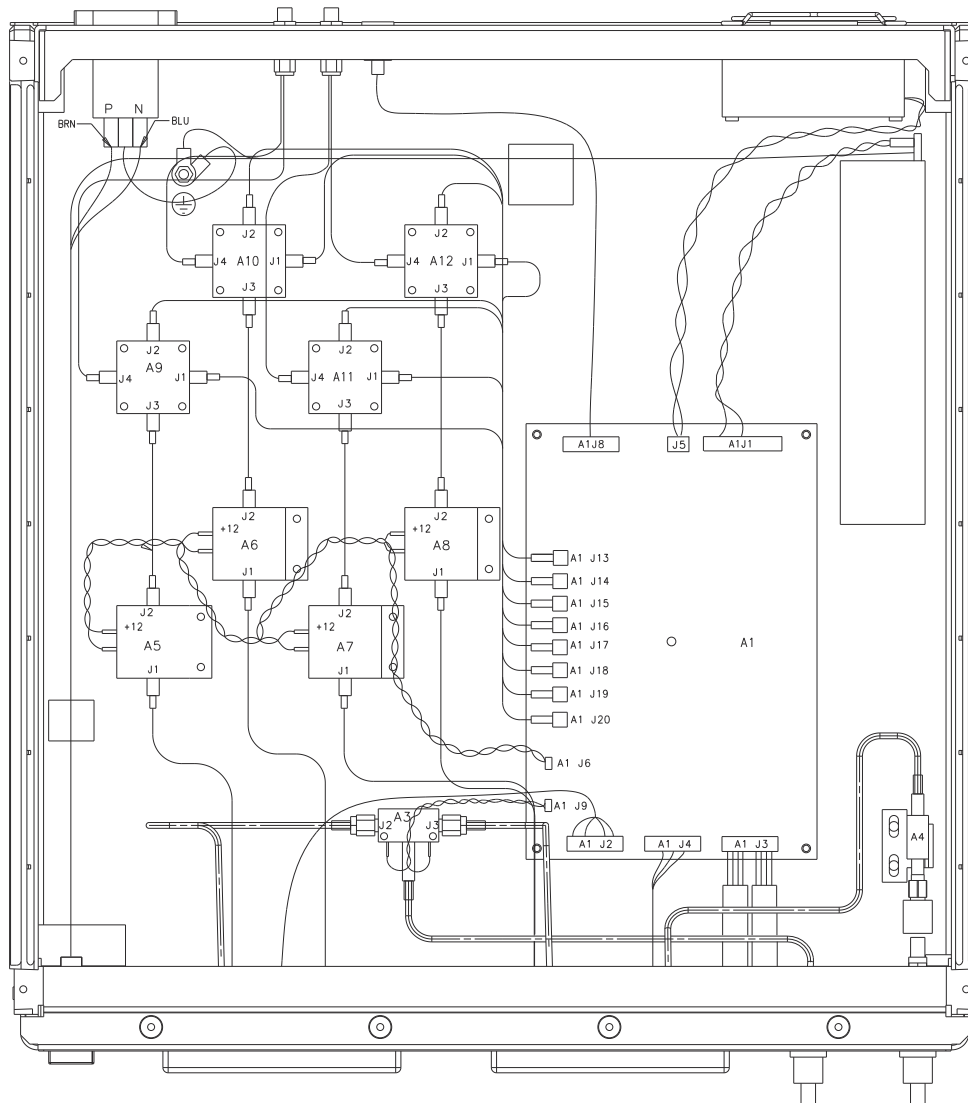

A1 – Control PCB Assembly  
 A3 – Transfer Switch  
 A4 – LO Power Divider  
 A5 – b1 IF Amplifier  
 A6 – a1 IF Amplifier  
 A7 – b2 IF Amplifier

A8 – a2 IF Amplifier  
 A9 – b1 IF Switch  
 A10 – a1 IF Switch  
 A11 – b2 IF Switch  
 A12 – a2 IF Switch

**Figure 6-2.** Part Location Diagram

## 6-6 Power Supply – 40-130

This section provides a procedure for removing and replacing the power supply in the 3738A Test Set.

### Procedure

1. Remove the top and bottom covers from the 3738A Test Set. Refer to [Section 6-4 “Removing the Covers” on page 6-2](#).
2. Unplug the power supply cable from A1J1 of the 54074-3 Control PCB Assembly. Refer to [Figure 6-2, “Part Location Diagram” on page 6-4](#).
3. Remove the protective terminal strip cover from the power supply.
4. Disconnect the power supply cables from the power supply terminal strip.
5. Place the test set on its left side.
6. Remove the three mounting screws that secure the power supply from the bottom side of the chassis. Use a hand to hold the power supply while removing the screws.
7. Remove the power supply from the 3738A Test Set.
8. To replace the power supply, reverse the order of the removal procedure. Ensure that the power supply cable is installed per [Figure 6-3, “Power Supply Cable Connection” on page 6-5](#).

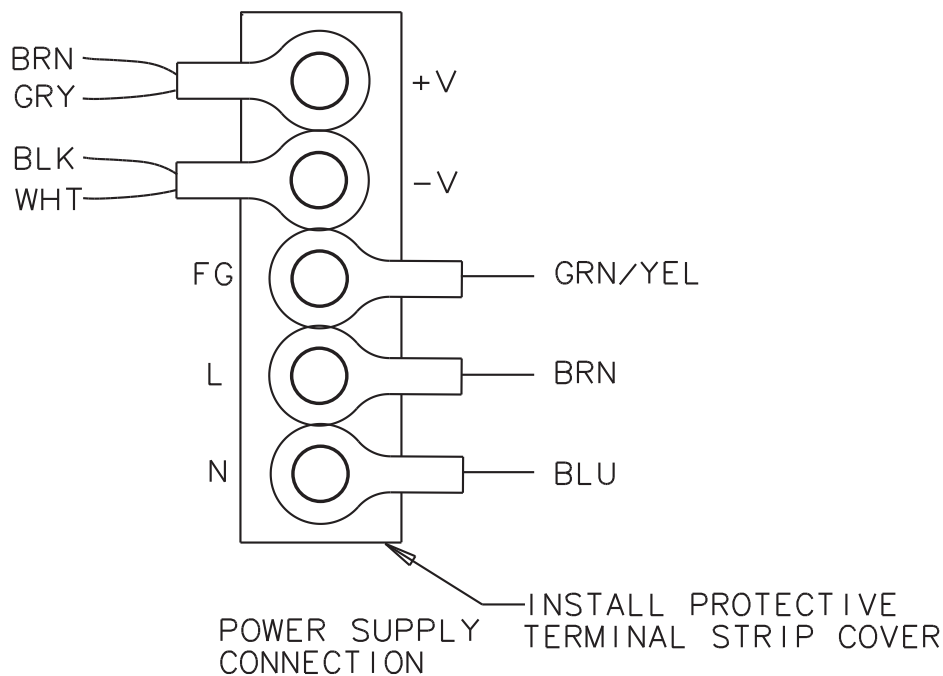

**Figure 6-3.** Power Supply Cable Connection

## 6-7 Control PCB Assembly – 54074-3

This section provides a procedure for removing and replacing the 54074-3 Control PCB Assembly in the 3738A Test Set.

### Procedure

1. Remove the top cover from the 3738A Test Set. Refer to [Section 6-4 “Removing the Covers” on page 6-2](#).
2. Disconnect all cable assemblies that are plugged into the 54074-3 Control PCB Assembly. Refer to [Figure 6-2, “Part Location Diagram” on page 6-4](#)
3. Remove the five mounting screws (2) that secure the 54074-3 Control PCB Assembly. Refer to [Figure 6-4, “54047-3 Control PCB Assembly Removal” on page 6-7](#)
4. Remove the 54074-3 Control PCB Assembly (1) from the 3738A Test Set.
5. To replace the 54074-3 Control PCB Assembly, reverse the order of the removal procedure.

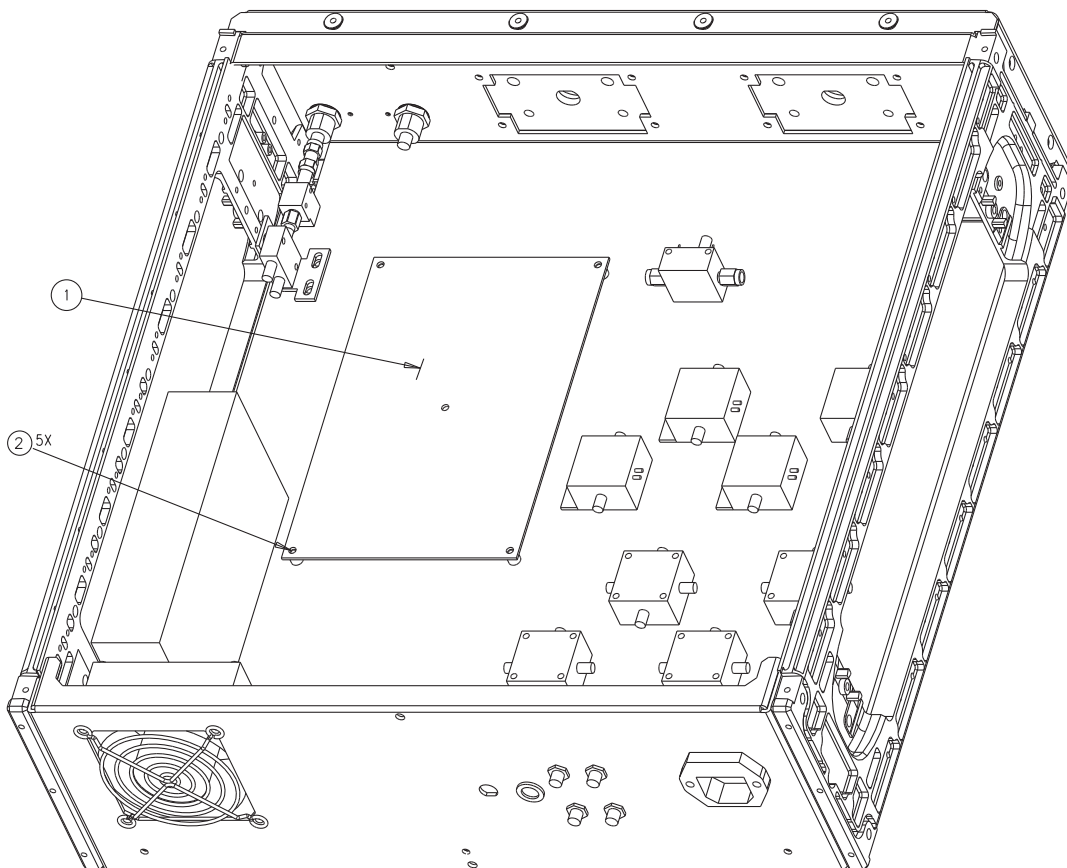

Figure 6-4. 54074-3 Control PCB Assembly Removal

## 6-8 LO Power Divider – 1091-87

This section provides a procedure for removing and replacing the 1091-87 LO Power Divider in the 3738A Test Set.

### Procedure

1. Remove the top cover from the 3738A Test Set. Refer to [Section 6-4 “Removing the Covers”](#) on page 6-2.
2. Disconnect the two RF cables from the LO power divider (4). Refer to [Figure 6-5, “LO Power Divider and LO Isolator Removal”](#) on page 6-8.
3. Remove the two screws (2) that secure the LO power divider bracket (1) to the chassis.
4. Loosen the connection between the LO power divider (4) and the LO isolator (5) until they are separated.
5. Remove the LO power divider (4) with its bracket from the 3738A Test Set.
6. Remove the two mounting screws (3) that secure the LO power divider (4) to the LO power divider bracket (1).
7. Remove the LO power divider (4) from the bracket (1).
8. To replace the LO power divider, reverse the order of the removal procedure. Use the Anritsu 01-201 (8 lbf in) torque wrench to tighten the RF connections prior to tightening all mounting screws.

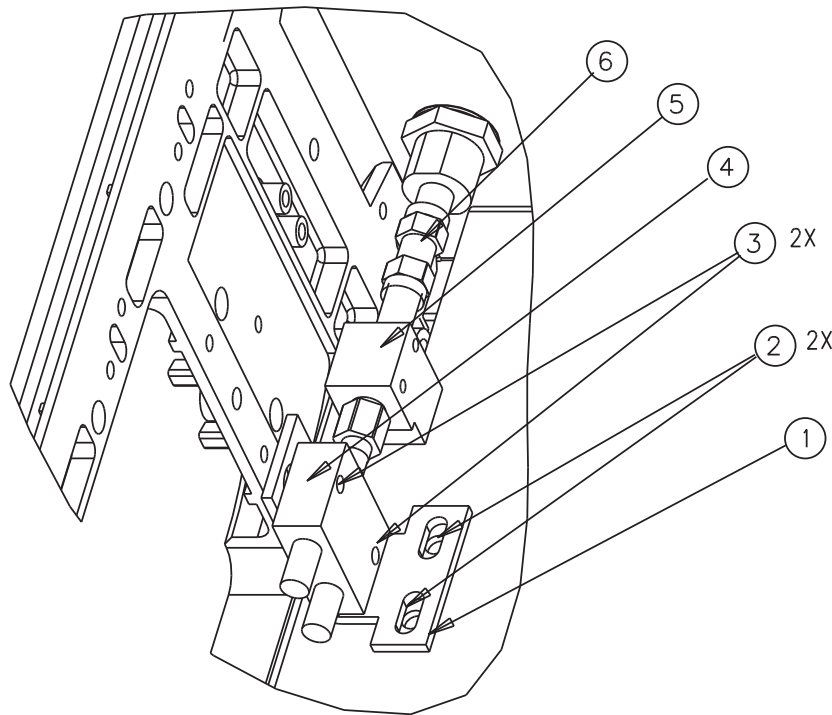

**Figure 6-5.** LO Power Divider and LO Isolator Removal

## 6-9 LO Isolator – 1000-49

This section provides a procedure for removing and replacing the 1000-49 LO Isolator in the 3738A Test Set.

### Procedure

1. Remove the top cover from the 3738A test set. Refer to [Section 6-4 “Removing the Covers” on page 6-2](#).
2. Remove the LO power divider. Refer to [Section 6-8 “LO Power Divider - 1091-87” on page 6-8](#)
3. Use a wrench to loosen the connection between the LO isolator (5) and the adapter (6) until the LO isolator is separated from the adapter. Refer to [Figure 6-5, “LO Power Divider and LO Isolator Removal” on page 6-8](#).
4. Remove the LO isolator from the 3738A Test Set.
5. To replace the LO isolator, reverse the order of the removal procedure. Use the Anritsu 01-201 (8 lbf in) torque wrench to tighten the connection between the LO isolator and the adapter.

## 6-10 Transfer Switch – ND57971

This section provides a procedure for removing and replacing the ND57971 Transfer Switch assembly in the 3738A Test Set.

### Procedure

1. Remove the top cover from the 3738A Test Set. Refer to [Section 6-4 “Removing the Covers” on page 6-2](#).
2. Unplug the transfer switch cable connector from A1 J9 of the 54074-3 Control PCB Assembly. Refer to [Figure 6-2, “Part Location Diagram” on page 6-4](#)
3. Disconnect the three RF cables from the transfer switch.
4. Remove the two mounting screws (2) from the transfer switch (1). Refer to [Figure 6-6, “Transfer Switch Removal” on page 6-10](#).
5. Remove the transfer switch from the 3738A Test Set.
6. To replace the transfer switch, reverse the order of the removal procedure. Use the Anritsu 01-201 (8 lbf in) torque wrench to tighten the connection between RF cable and the transfer switch.

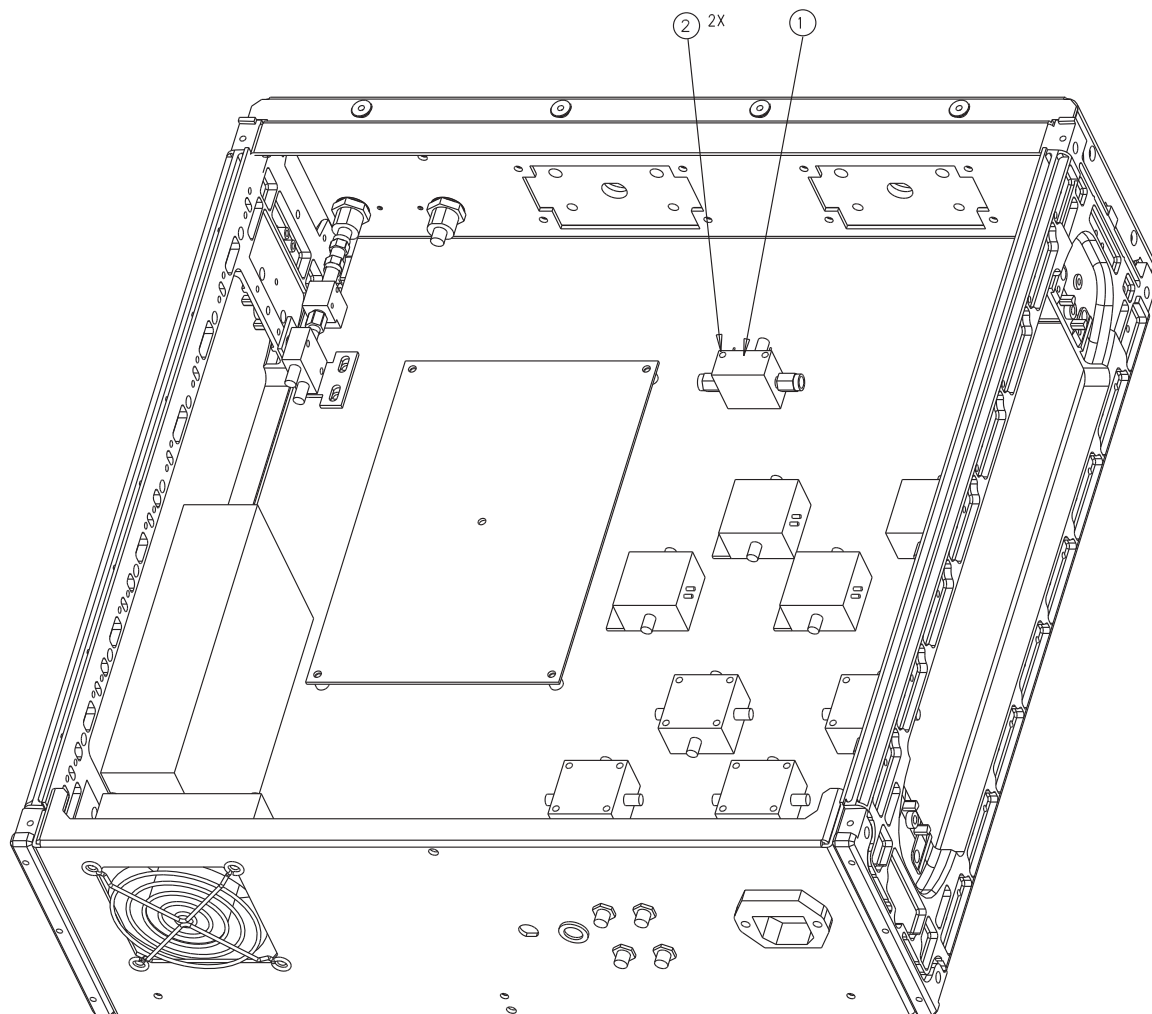

**Figure 6-6.** Transfer Switch Removal



## 6-11 IF Amplifiers – 60-279

This section provides a procedure for removing and replacing the 60-279 IF Amplifiers in the 3738A Test Set. All IF amplifiers are mounted to the chassis in the same manner.

### Procedure

1. Remove the top cover from the 3738A Test Set. Refer to [Section 6-4 “Removing the Covers” on page 6-2](#).
2. Locate the respective defective IF amplifier that needs to be replaced. Refer to [Figure 6-2, “Part Location Diagram” on page 6-4](#).
3. De-solder the DC bias wires from the IF amplifier.
4. Disconnect the two RF cables from the IF amplifier.
5. Remove the two mounting screws (2) from the IF amplifier (1). Refer to [Figure 6-7, “IF Amplifier and IF Switch Removal” on page 6-12](#).
6. Remove the IF amplifier (1) from the 3738A Test Set.
7. To replace the IF amplifier, reverse the order of the removal procedure. Use the Anritsu 01-201 (8 lbf in) torque wrench to tighten the connection between RF cable and the IF amplifier.

<b>Note</b> Ensure that the white DC bias wire is soldered to the +12V terminal on the IF amplifier.
--

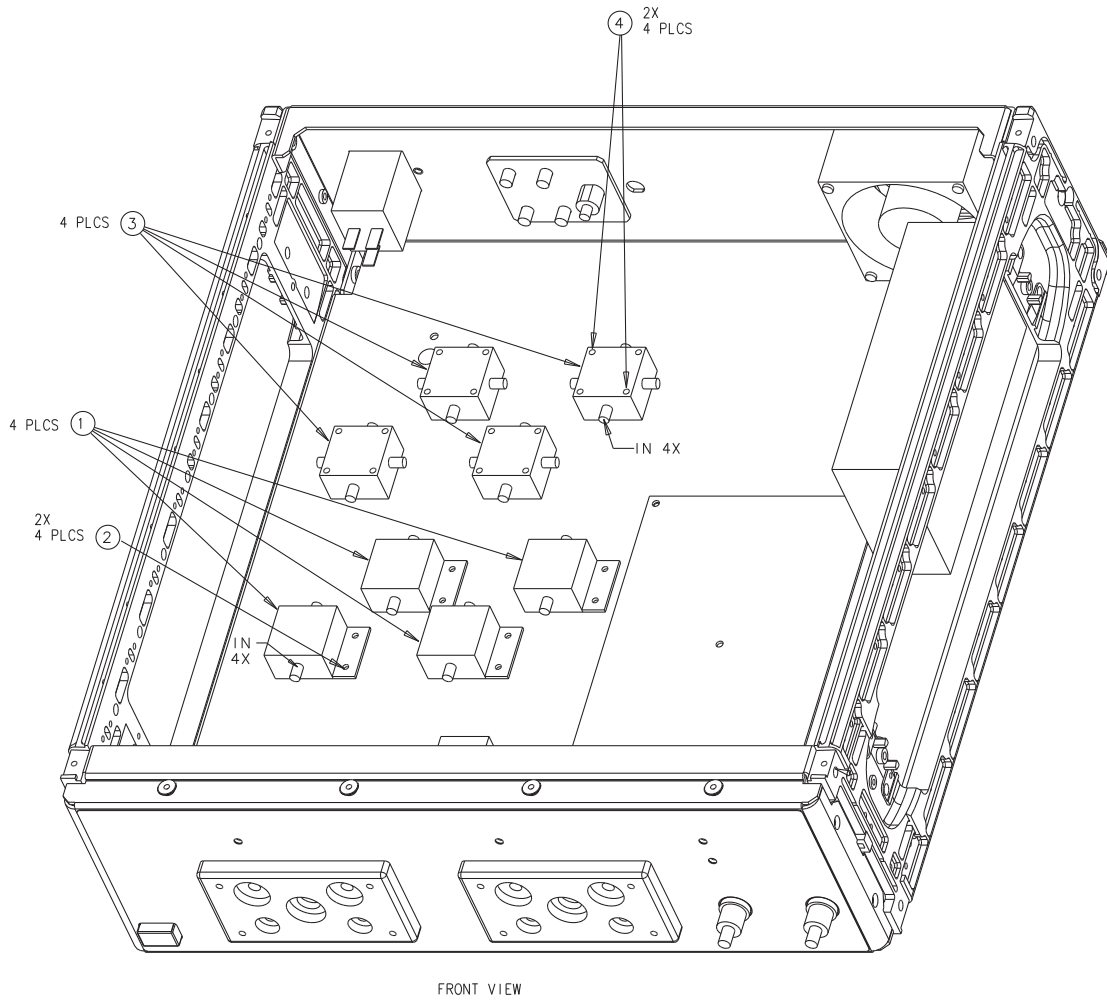

Figure 6-7. IF Amplifier and IF Switch Removal

## 6-12 IF Switches – 1020-44

This section provides a procedure for removing and replacing the 1020-44 IF Switches in the 3738A Test Set. All IF switches are mounted to the chassis of the test set in the same manner.

### Procedure

1. Remove the top cover from the 3738A Test Set. Refer to [Section 6-4 “Removing the Covers” on page 6-2](#).
2. Locate the respective defective IF switch that needs to be replaced. Refer to [Figure 6-2, “Part Location Diagram” on page 6-4](#)
3. Disconnect the four RF cables from the IF switch.
4. Remove the two mounting screws (4) from the IF switch (3). Refer to [Figure 6-7, “IF Amplifier and IF Switch Removal” on page 6-12](#).
5. Remove the IF switch (3) from the 3738A Test Set.
6. To replace the IF switch, reverse the order of the removal procedure. Use the Anritsu 01-201 (8 lbf in) torque wrench to tighten the connection between RF cable and the IF switch.

## 6-13 Rear Panel Fan Assembly - ND58282

This section provides a procedure for removing and replacing the ND58282 Rear Panel Fan Assembly in the 3738A Test Set.

### Procedure

1. Remove the top cover from the 3738A Test Set. Refer to [Section 6-4 “Removing the Covers”](#) on page 6-2.
2. Unplug the fan power cable from A1J5 of the 54074-3 Control PCB Assembly. Refer to [Figure 6-2, “Part Location Diagram”](#) on page 6-4.
3. Remove the four fan guard locking nuts (3). Refer to [Figure 6-8, “Fan Assembly Removal”](#) on page 6-14.
4. Remove the fan guard (5) from the rear panel (1) of the 3738A Test Set.
5. Remove the four nuts (5) and four screws (2).
6. Remove the fan assembly (4) from the 3738A Test Set.
7. To replace the fan assembly, reverse the order of the removal procedure.

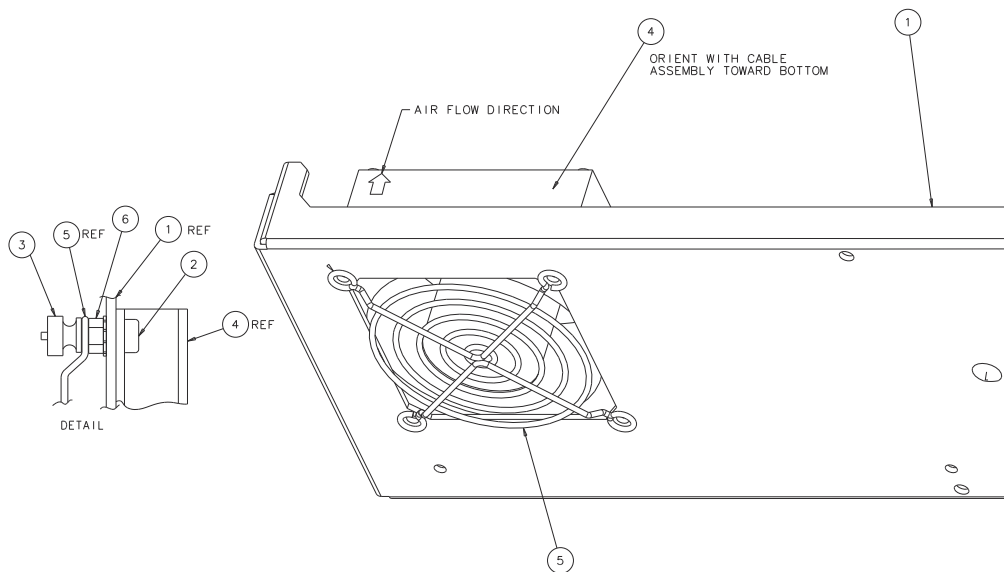

**Figure 6-8.** Fan Assembly Removal

## 6-14 Front Panel LED Cable Assembly - ND74548

This section provides a procedure for removing and replacing the ND74548 Front Panel LED Cable Assembly in the 3738A Test Set.

### Procedure

1. Remove the top cover from the 3738A Test Set. Refer to [Section 6-4 “Removing the Covers”](#) on page 6-2.
2. Unplug the front panel LED cable assembly from A1J3 of the 54074-3 Control PCB Assembly. Refer to [Figure 6-2, “Part Location Diagram”](#) on page 6-4.
3. Remove the four LEDs from the front panel of the 3738A Test Set.
4. Remove the front panel LED cable assembly from the 3738A Test Set.
5. To replace the front panel LED cable assembly, reverse the order of the removal procedure. Ensure that the respective LED is inserted to its respective location on the front panel as shown in [Figure 6-9, “Front Panel LED Cable Assembly”](#) on page 6-15.

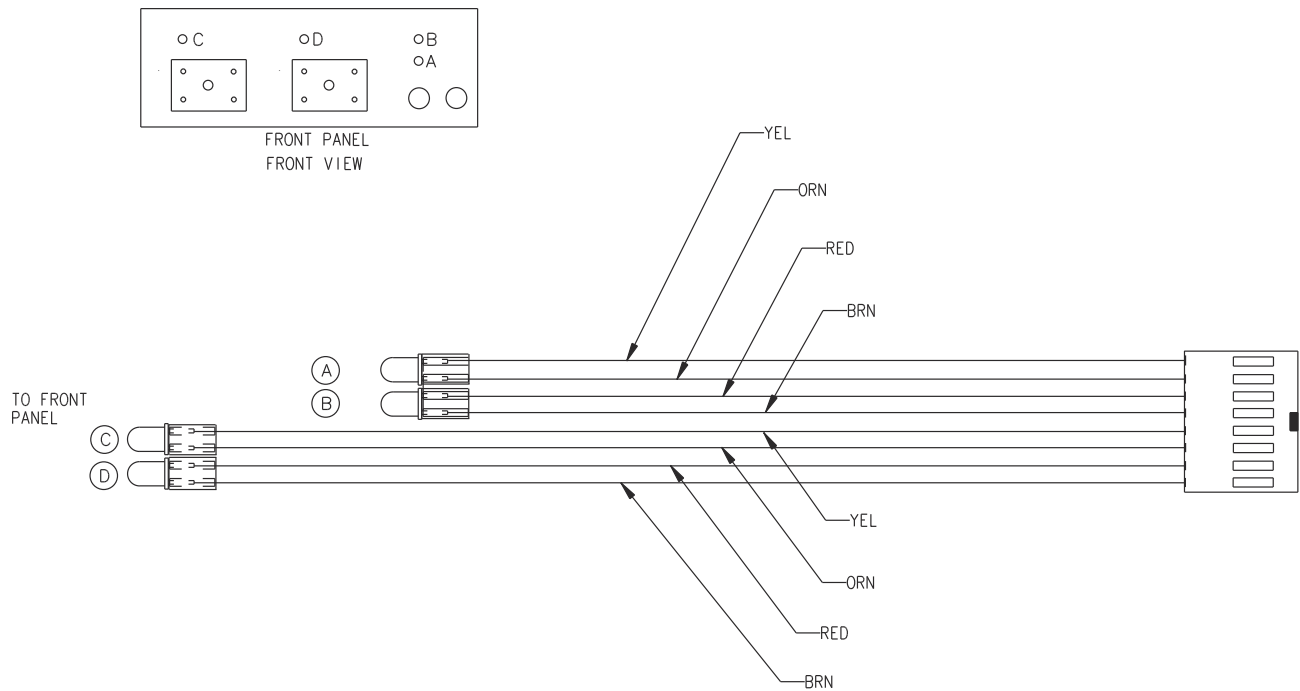

**Figure 6-9.** Front Panel LED Cable Assembly



# Appendix A — Test Records

## A-1 Introduction

This appendix provides test records that can be used to record the performance of the ME7828A Millimeter-Wave configuration VNA System.

Make a copy of the following Test Record pages and document the measured values each time performance verification is performed. Continuing to document this process each performance verification session provides a detailed history of the instrument's performance.

## A-2 ME7828A Millimeter-Wave Configuration VNA System Test Record

### Instrument Information

3738A Serial Number:	Operator:	Date:
VectorStar VNA Model: MS4642A [ ] MS4644A [ ] MS4645A [ ] MS4647A [ ]	VectorStar VNA Serial Number:	VectorStar VNA Options: 051 [ ] 061 [ ] 062 [ ] 070 [ ]
Port 1 Millimeter-Wave Module Model:	Module Serial Number:	
Port 2 Millimeter-Wave Module Model:	Module Serial Number:	
System Signal Source Model:	Signal Source Serial Numbers:	

### Directivity

Table A-1. Directivity

Freq (GHz)	Port 1 Module	Port 2 Measured	Port 1 Measured	Port 2 Measured	Specification
50 to 75	3740A-V	3740A-V	dB	dB	>46 dB
50 to 75	3740A-V	3741A-V	dB	NA	>46 dB
60 to 90	3740A-E	3740A-E	dB	dB	>46 dB
60 to 90	3740A-E	3741A-E	dB	NA	>46 dB
56 to 94	3740A-EE	3740A-EE	dB	dB	>44 dB
56 to 94	3740A-EE	3741A-EE	dB	NA	>44 dB
75 to 110	3740A-W	3740A-W	dB	dB	>46 dB
75 to 110	3740A-W	3741A-W	dB	NA	>46 dB
65 to 110	3740A-EW	3740A-EW	dB	dB	>40 dB
65 to 110	3740A-EW	3741A-EW	dB	NA	>40 dB



## Test Port Match

Table A-2. Test Port Match

Freq (GHz)	Port 1 Module	Port 2 Module	Port 1 Measured	Port 2 Measured	Specification
50 to 75	3740A-V	3740A-V	dB	dB	>37 dB
50 to 75	3740A-V	3741A-V	dB	NA	>37 dB
60 to 90	3740A-E	3740A-E	dB	dB	>36 dB
60 to 90	3740A-E	3741A-E	dB	NA	>36 dB
56 to 94	3740A-EE	3740A-EE	dB	dB	>33 dB
56 to 94	3740A-EE	3741A-EE	dB	NA	>33 dB
75 to 110	3740A-W	3740A-W	dB	dB	>36 dB
75 to 110	3740A-W	3741A-W	dB	NA	>36 dB
65 to 110	3740A-EW	3740A-EW	dB	dB	>30 dB
65 to 110	3740A-EW	3741A-EW	dB	NA	>30 dB



# Appendix B — Specifications

## B-1 Technical Data Sheet

Use this tab to store the latest version of the VectorStar technical data sheets:

- VectorStar MS4640A Series VNA Technical Data Sheet - 11410-00435
- VectorStar ME7828A Series Broadband/Millimeter-Wave VNA System Technical Data Sheet - 11410-00452

These and other related VectorStar documents are available on the Anritsu web at:

- <http://www.anritsu.com/en-US/Products-Solutions/Products/MS4640A-Series.aspx>





# Anritsu

---



Anritsu prints on recycled paper with vegetable soybean oil ink.

Anritsu Company  
490 Jarvis Drive  
Morgan Hill, CA 95037-2809  
USA  
<http://www.anritsu.com>