



EZILoader



# Clothes Dryer Instruction Booklet

Congratulations on your choice of clothes dryer  
which will give you many years of easy loading  
and easy drying in the Simpson tradition

# Contents

Important Safety Information	
Dryer Safety	page 2
Fire Hazards	page 2
Cleaning the Lint Filter	page 3
Drying Guide	page 3
Installation Instructions	page 4
Quick 5 Step Operating Guide	page 5
Useful Hints	page 5
Useful Hints (continued)	page 6
Troubleshooting	page 6
Accessories	page 6
Warranty	page 7
Purchase Details	page 8

## Important Safety Instructions

### DRYER SAFETY

Failure to follow these safety instructions could damage the dryer or your clothes.

**You may then not be covered by warranty for this damage.**

Only plug this appliance directly into an AC power supply, which is properly earthed and has the correct voltage. See the serial number sticker located on the top of the door opening for voltage information.

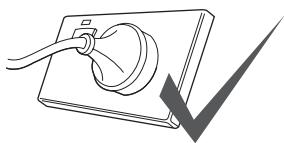

**CAUTION:** If this appliance is supplied from a cord extension set or electrical portable outlet device, the cord extension set or electrical portable outlet device must be positioned so that it is not subject to splashing or ingress of moisture. For safety reasons we strongly advise against the use of double adaptors, extension cords or power boards.

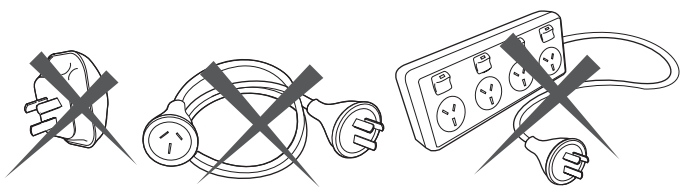

This tumble dryer is not intended for use by young children or infirm persons without supervision. Young children should be supervised to ensure that they do not play with the appliance.

**IMPORTANT:** If the electrical cord of this appliance is damaged, it must be replaced by the Manufacturer, Authorised Service Agent or similarly qualified person in order to avoid a hazard.

**These dryers are for drying clothes, towels and linen at home. Do not use them for any other purpose.**

### FIRE HAZARDS

Some fabrics are not suitable for tumble drying. The following **MUST NOT** be placed in your dryer due to the risk of a fire or an explosion:

- Items that have been spotted or soaked with **vegetable oil, cooking oil, suntan oil, linseed oil, salad oil, lubrication oil or grease**. Oil affected items can ignite spontaneously, especially when exposed to heat sources such as in a tumble dryer. The items become warm, causing an oxidation reaction in the oil. Oxidation creates heat. If heat cannot escape, the items can become hot enough to ignite. Piling, stacking, or storing oil-affected items can prevent heat from escaping and create a fire hazard. If it is unavoidable that fabrics that contain vegetable or cooking oil, or have been contaminated by hair care products be placed in a tumble dryer, they should first be washed in hot water with extra detergent - this will reduce, but not eliminate the hazard. The 'cool down' cycle of tumble dryers should be used to reduce the temperature of the items. They should not be removed from the tumble dryer or piled while hot.
- Items that have previously been cleaned in, washed in, or spotted with **petrol/gasoline, industrial chemicals used only for cleaning, dry-cleaning solvents or other flammable or explosive substances**. Highly flammable substances commonly found around the house include acetone, (nail polish remover) denatured alcohol, petrol/gasoline, kerosene, some spot removers, turpentine, waxes and wax removers. Items containing foam rubber (also known as latex foam) or similarly textured rubber-like materials. Foam rubber materials can produce fire by spontaneous combustion when heated.
- Rubber-backed articles, clothes fitted with foam rubber pads, pillows, rubber boots and rubber-coated sports shoes.



For your safety, and to reduce the risk of fire or an explosion, **DO NOT** store or use petrol or other flammable liquids and liquids near your dryer.

# Important Safety Instructions

## LINT BUILD-UP IS A FIRE HAZARD

A clean lint filter reduces drying times, saves energy and avoids overheating. Overheating may also damage your clothes.

What happens if I forget to clean the lint filter?

Drying Time

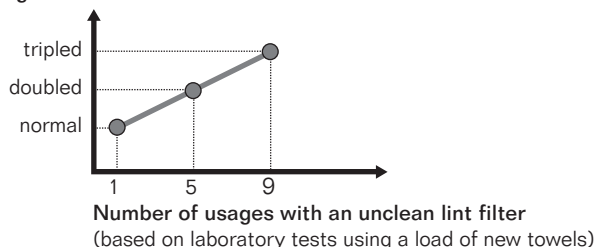

The lint filter is located at the front of your dryer at the bottom of the door opening.

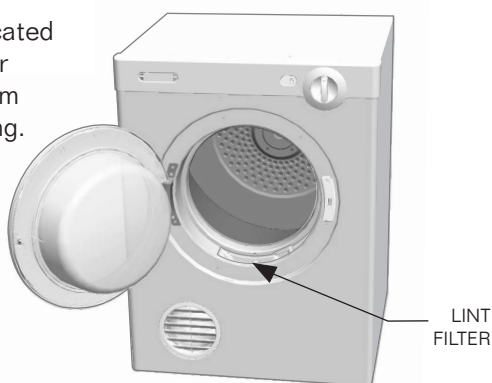

You must clean this lint filter after every load.

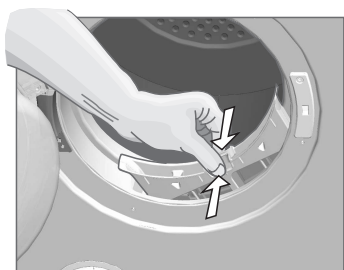

To remove the lint filter open the door and press the two pads together. Pull the lint filter out of the pocket.

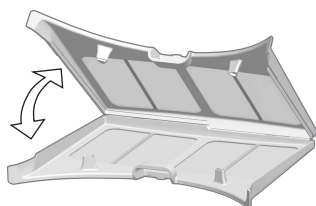

Open apart the lint filter and wipe or peel off the lint.

Ensure the lint filter 'clicks' when replacing. It can be inserted into the pocket either way.

- Never operate your dryer without the lint filter.
- Do not allow lint to build up around your dryer.
- A torn or damaged lint filter must be replaced immediately.
- Overloading can increase lint build-up because the airflow is reduced.

To avoid potential fire hazards, we recommend that you pay a qualified service technician to periodically clean your dryer. You must do this also when you change your mounting from upright to inverted, or vice versa.

## DRYING GUIDE

Your load, when dry must not exceed the rated capacity.

- 4kg for the 4kg Machine
- 5kg for the 5kg Machine
- 6kg for the 6kg Machine

(See page 6 for a table of average weights of laundry items)

Always check your labels for the drying symbols which the International Care Labelling Code now uses.



- **Permanent press and synthetics** - take out as soon as the dryer stops to reduce wrinkles.
- **Woollen articles** - not recommended. Pull them to their original shape, then dry them flat.
- **Woven and loop knit materials** - may shrink, by varying amounts, depending on their quality. Do not use the 'hot' setting for these fabrics. Always stretch them out immediately after drying.
- **Fibre or leather materials** - always check the manufacturer's instructions.
- **Baby clothes and night gowns** - acrylic clothing or sleepwear use only on the 'warm' setting.
- **Rubber and plastics** - Do not dry any items made from or containing rubber or plastics, such as aprons, bibs, babies' waterproof napkins, curtains, tablecloths, shower caps, clothes fitted with foam rubber pads, pillows, galoshes, or rubber coated tennis shoes.
- **Fibreglass** - not recommended. Glass particles left in the dryer could be picked up by your clothes the next time you use the dryer, and irritate your skin.

During the drying cycle, if you want to

- add or take out clothes, or
- check the dryness of the load,

turn down the timer to 'Airing' for at least one minute before opening the door. This is to prevent scorching or possible self combustion of the fabric.

Fabric softeners or similar products should not be used in a tumble dryer to eliminate the effects of static electricity unless this practice is specifically recommended by the manufacturer of the fabric softener or product.

Note: We strongly advise against the use of fabric conditioners of the sheet type that are added to the clothes in the drum. These products may lead to rapid blockage of the lint filter and inefficient operation of your dryer.

# Installation Instructions

You can choose to put your dryer:-

- on the floor.
- on a work bench.
- on a wall, upside down or upright, using the included mounting kit.
- on top of a front load washing machine (using a stacking kit available as an optional extra).

The appliance must not be installed behind a lockable door, a sliding door or a door with a hinge on the opposite side to that of the tumble dryer in such a way that a full opening of the tumble dryer door is restricted.

## Stacking Kit

You can use a stacking kit if you want to mount your dryer on top of a Simpson front load washing machine. Use the kit part number DKSK03. Refer to the kit instructions on how to install.

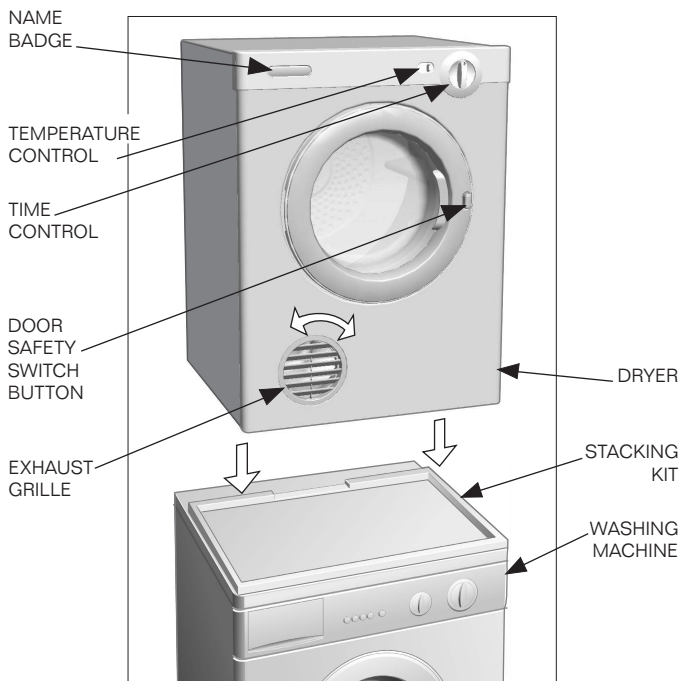

The exhaust grille has a range of positions, which allows you to select the optimum exhaust air angle. Simply hold the grille and rotate it until it hits the built-in stop.

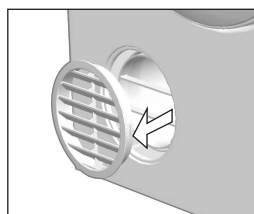

removable exhaust grille

## Name Badge

You can invert the name badge when you want to mount your dryer upside down on the wall.

Use a suitable tool (such as a thin bladed tool). Unclip the badge from the panel, invert and clip back.

**Do not install your dryer in a cupboard or small un-vented laundry unless you are using a venting kit.**

There are 2 VENTING OPTIONS

- front
- rear - using a venting kit (optional extra)

## Venting Kit

DVK005 - Through the wall

DVK006 - Universal flexible hose

**Important:** Use only kits approved by Electrolux Home Products Pty Ltd with your dryer. Contact the Electrolux Home Products Pty. Ltd. Spare Parts Centre for the list of approved kits. The exhaust duct must not exceed 2 metres in length and 100mm in diameter.

If connecting the dryer to a common ducting system, safety advice should be requested from the manufacturer.

If you choose to use an optional vent kit, the exhaust grille at the front of the dryer will need to be replaced with the outlet cover from the back of the dryer. Gently prise open the grille, using a thin bladed tool. Next, remove the cover from the back and clip it into the grille space at the front. The exhaust grille is not required when using a vent kit.

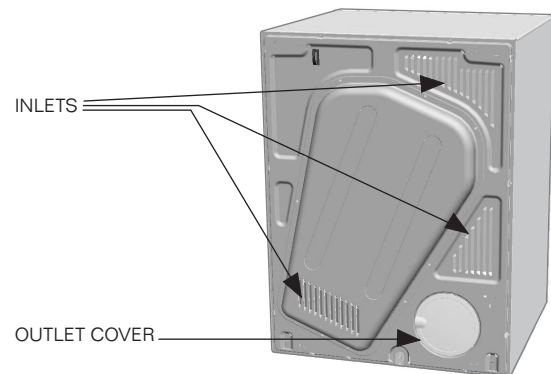

You can position the vent kit at the back of the dryer to remove air upwards or sideways.

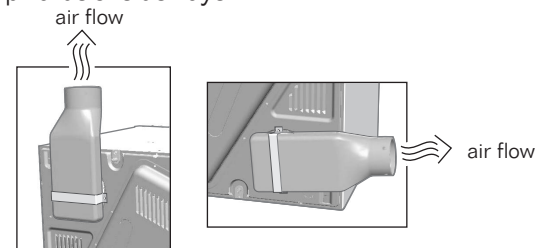

Inlet and outlet points need clear airflow to prevent overheating, so ensure there is adequate ventilation. (i.e. open window or external door.)

If a venting kit is used and the exhaust is discharged out of the room, there must be adequate ventilation to avoid the back flow of gases into the room from appliances burning other fuels, including open fires, when operating the tumble dryer. This is not applicable where a venting hose is directed to an open window. The exhaust air must not be discharged into a flue which is used for exhausting fumes from appliances burning gas or other fuels.

# Quick 5 Step Operating Guide

- 1** Load your dryer loosely until it is no more than **TWO THIRDS FULL**. Clothes must tumble freely in a dryer. Don't cram them in. Wet clothes fluff up when dry.



#### Overloading will:

- Reduce efficiency
- Increase drying time
- Increase the risk of creasing

Do not load clothes or other articles which are dripping wet into your dryer.

- 2** Select one of the two (2) temperature settings.

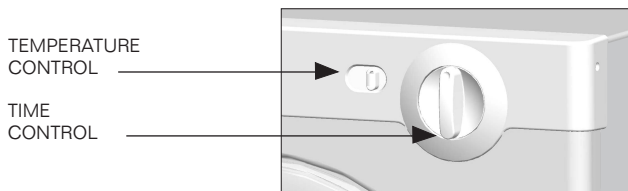

- ☀️ 'Warm' for delicate items which can shrink, such as synthetics, underwear, etc.
- ☀️ 'Hot' for heavy, durable items such as towels and flannelette sheets.

- 3** Select the drying time.

Only turn the control knob clockwise.

- 4** Switch On

The dryer will not operate unless the safety button on the door is fully pressed in.

DOOR  
SAFETY  
SWITCH  
BUTTON

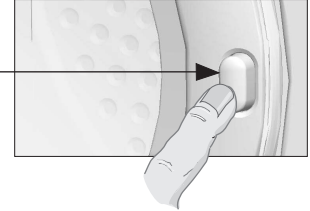

- 5** Clean Lint Filter

After every load clean the lint filter located at the front of your dryer to reduce drying times and avoid overheating.

## STANDARD FEATURES

### Reversing Action

The drum is designed to turn one minute in each direction, clockwise and anti-clockwise. This reduces tangling and gives more even drying in a shorter time.

### Cooling Down

At the end of the drying cycle, there is automatically a time of no heat, to cool down the load and minimise creasing.

## Useful Hints

- Never tumble dry the following: Delicate items such as net curtains, woollen, silk, fabric with metal trim, nylon tights, bulky materials such as anoraks, blankets, eiderdown, sleeping bags, feather quilts and any item containing rubber foam or materials similar to foam rubber.
- Do not place in your dryer undergarments such as bras and corsets that contain metal reinforcements. Your dryer may be damaged if metal parts were to come loose from the garment. Place such items in a bag designed for this purpose.
- Check and empty pockets. Clips, pens, nails and pins can damage both the dryer and your clothes. Other items such as matches or cigarette lighters will cause a fire.
- Close all press studs, hooks, eyes and zips that may catch on something else. Tie all belts and apron strings to prevent tangling.
- Drying time will depend on fabric type and construction, load size and wetness. Save time and money and always spin the load as dry as possible in your washing machine.

- Drying time will also be affected by voltage fluctuations, room temperature and humidity. Clothes will dry more slowly on a cool or humid day.
- For best results, sort the load according to fabric types. Such as heavy items which may take longer to dry, eg towels, flannelette sheets etc, than ones which dry quickly, eg poly/cotton shirts and sheets.
- Avoid drying dark clothes with light coloured items such as towels as lint will show on the dark clothes.

**Note: Some fabrics will collect lint from other clothes and items. Separate the lint 'givers' and the lint 'collectors' to minimise this problem.**

Clothes that give lint include towels, nappies, chenille. Clothes that collect lint include corduroy, synthetics and permanent press garments.

- If individual items are still damp after drying, set a 30 minute post drying time. This will be necessary particularly for multilayered items (eg collars, pockets, etc).
- Always clean the lint filter - this will reduce drying time and save you money.

# Useful Hints, Troubleshooting & Accessories

## USEFUL HINTS (continued)

- The laundry must be thoroughly spun before tumble drying.
- Easy-care items eg shirts, should be briefly pre-spun before drying (depending on the crease resistance approximately 30 seconds)
- To avoid static charge when drying is completed, use either a fabric softener when you are washing the laundry or a fabric conditioner specifically for tumble dryers.
- Remove the laundry when the dryer has finished drying.
- Do not over-dry laundry, this avoids creasing and saves energy.
- Clothes or towels containing sand or grit should be washed first.

To help you, here is a list of the average weights of some common laundry items.

Sheet	700 - 1000g
Tablecloth	400 - 500g
Kitchen towel	70 - 120g
Table napkin	50 - 100g
Towelling hand towel	150 - 250g
Bathrobe	1000 - 1500g
Men's shirt	200 - 300g
Pillowcase	100 - 200g
Men's pyjamas	400 - 500g
Ladies nightdress	200 - 250g

## TROUBLESHOOTING

Check the points listed here **before** you call for help, and **make sure that you have followed the Important Safety Information on pages 2 & 3.**

**If you can't start your dryer, check these probable causes.**

- Plug is not firmly in socket, or power not turned on.
- You have blown a fuse. Check that power point with another appliance.
- You have not closed the dryer door or pushed in the door safety switch button.
- You have not turned the control knob to the setting you want.

**If your clothes are still wet:**

- The selected drying time was insufficient. Turn the control knob to a longer time setting.
- Longer time may be needed when the room temperatures is 10° C or less.
- Check that the lint filter is not blocked.
- Check to see that you have read all the instructions carefully.
- Contact the Service Centre if you are still having problems. Write down the model and serial numbers and the date of purchase before you ring. The Service Centre will need this information.

### Important

To operate efficiently the clothes dryer must have an unrestricted air supply and exhaust ventilation.

**Service calls resulting from installation where ventilation is restricted are not covered by warranty.**

**THE COST OF THIS TYPE OF CALL WILL BE CHARGED TO THE CUSTOMER.**

Should you require further instructions in the use and care of your clothes dryer please contact the CUSTOMER CARE CENTRE on the phone numbers listed:

Australia... **1300 363 640** 8am to 7pm EST & 8pm EDST  
Monday to Friday

New Zealand... **(09) 573 2384** 8am to 5pm  
Monday to Friday

If you have a warranty or spare parts enquiry you should call the number listed on page 7.

## ACCESSORIES

You can buy both the venting kits and the stacking kit (as mentioned on page 4) from you local appliance shop or Electrolux Home Products Pty. Ltd. Spare Parts Distributor.



# Electrolux Warranty

FOR SALES IN AUSTRALIA AND NEW ZEALAND  
APPLIANCE: SIMPSON DRYER

This document sets out the terms and conditions of product warranties for Electrolux branded appliances. It is an important document. Please keep it with your proof of purchase documents in a safe place for future reference should you require service for your Electrolux appliance.

## General Terms and Conditions

1. In this warranty
  - (a) 'Electrolux' means Electrolux Home Products Pty Ltd ABN 51 004 762 341 in respect of Appliances purchased in Australia and Electrolux (NZ) Limited in respect of Appliances purchased in New Zealand;
  - (b) 'Appliance' means any Electrolux product purchased by you accompanied by this document;
  - (c) 'Warranty Period' means
    - (i) where you use the Appliance for personal, domestic or household purposes in Australia the period of 12 months and in New Zealand the period of 24 months;
    - (ii) where you use the Appliance for commercial purposes, in Australia the period of 3 months and in New Zealand the period of '3' months, (if the period stated is 0 months you are not covered by this product warranty) following the date of original purchase of the Appliance;
  - (d) 'you' means the purchaser of the Appliance not having purchased the appliance for re-sale, and 'your' has a corresponding meaning.
2. This warranty only applies to Appliances purchased and used in Australia or New Zealand and is in addition to (and does not exclude, restrict, or modify in any way) any non-excludable statutory warranties in Australia or New Zealand.
3. Electrolux warrants that, when dispatched from an Electrolux warehouse, the Appliance is free from defects in materials and workmanship for the Warranty Period.
4. During the Warranty Period Electrolux or its Authorised Service Centre will, at no extra charge if your appliance is readily accessible without special equipment, and subject to these terms and conditions, repair or replace any parts which it considers to be defective. You agree that any replaced Appliances or parts become the property of Electrolux. This warranty does not apply to light globes, batteries, filters or similar perishable parts.
5. Parts and Appliances not supplied by Electrolux are not covered by this warranty.
6. Where you are within an Electrolux service area, this warranty covers the cost of transport of the Appliance to and from Authorised Service Centres of Electrolux and travelling costs for representatives of the Authorised Service Centre to and from your home or business. If you are outside an Electrolux service area, you will bear these costs. For information about whether you are within an Electrolux service area, please phone 13 13 49 in Australia, or 0800 10 66 10 in New Zealand.
7. Proof of purchase is required before you can make a claim under this warranty.

8. You may not make a claim under this warranty unless the defect claimed is due to faulty or defective parts or workmanship. Electrolux is not liable in the following situations (which are not exhaustive):
  - (a) The Appliance is damaged by:
    - (i) accident
    - (ii) misuse or abuse, including failure to properly maintain or service
    - (iii) normal wear and tear
    - (iv) power surges, electrical storm damage or incorrect power supply
    - (v) incomplete or improper installation
    - (vi) incorrect, improper or inappropriate operation
    - (vii) insect or vermin infestation.
  - (b) The Appliance is modified without authority from Electrolux in writing.
  - (c) The Appliance's serial number or warranty seal has been removed or defaced.
  - (d) The Appliance was serviced or repaired by anyone other than Electrolux or its Authorised Service Centres.
9. This warranty, the contract to which it relates and the relationship between you and Electrolux are governed by the law applicable in the Australian State where the Appliance was purchased or the law applicable in New Zealand if the Appliance was purchased in New Zealand. Where the Appliance was purchased in New Zealand for business purposes the Consumer Guarantee Act does not apply.

## Limitation of Liability

10. To the extent permitted by law:
  - (a) Electrolux excludes all warranties other than as contained in this document;
  - (b) Electrolux shall not be liable for any loss or damage whether direct or indirect or consequential arising from your purchase, use or non-use of the Appliance.
11. Provisions of the Trade Practices Act and State consumer legislation in Australia, and the Consumer Guarantees Act, the Sale of Goods Act and the Fair Trading Act in New Zealand, imply warranties or conditions, or impose obligations, upon Electrolux which cannot be excluded, restricted or modified. To the extent permitted by law, the liability of Electrolux (if any) arising out of or in relation to the Appliance or any services supplied by Electrolux shall be limited (where it is fair and reasonable to do so),:
  - (a) in the case of Appliances, at its option, to the replacement or repair of the Appliances or the supply of equivalent products or the payment of the cost of replacing the Appliances or having the Appliances repaired or of acquiring equivalent Appliances. Upon being replaced, parts and Appliances become the property of Electrolux; or
  - (b) in the case of services, at its option, to the supply of the services again or the payment of the cost of having the services re-supplied;
 and in the case of Appliances or services supplied in New Zealand, loss or damage whether direct or indirect or consequential that is reasonably foreseeable.

## Privacy

You acknowledge that in the event that you make a warranty claim it will be necessary for Electrolux and its Authorised Service Centres to exchange information in relation to you to enable Electrolux to meet its obligations under this warranty.

## Important Notice

Before calling a Service Technician please check carefully the operating instructions, service booklet and the warranty terms and conditions.

<p><b>FOR SERVICE</b> OR TO FIND THE ADDRESS OF YOUR NEAREST STATE SERVICE CENTRE IN AUSTRALIA <b>Please call 13 13 49</b> <small>For the cost of a local call (Australia only)</small></p>	<p><b>SERVICE AUSTRALIA</b>  <b>Electrolux</b> <b>ELECTROLUX HOME PRODUCTS</b></p>	<p><b>FOR SPARE PARTS</b> OR TO FIND THE ADDRESS OF YOUR NEAREST STATE SPARE PARTS CENTRE IN AUSTRALIA <b>Please call 13 13 50</b> <small>For the cost of a local call (Australia only)</small></p>
<p><b>FOR SERVICE</b> OR TO FIND THE ADDRESS OF YOUR NEAREST AUTHORISED SERVICE CENTRE IN NEW ZEALAND <b>Free call 0800 10 66 10</b> <small>(New Zealand only)</small></p>	<p><b>NEW ZEALAND SPARE PARTS CENTRES</b></p> <p><b>AUCKLAND</b> Prime Distributors Ltd. 8 Highbrook Drive, East Tamaki.....(09) 273 3580  <b>CHRISTCHURCH</b> Prime Distributors Ltd. Unit 1, 127 Montreal Street.....(03) 377 1009                  R. Redpath Ltd. 55 Ferry Road.....(03) 379 0115  <b>DUNEDIN</b> Appliance Parts Company, 590 Hillside Road.....(03) 551 5112</p> <p> <b>Electrolux</b> <b>ELECTROLUX HOME PRODUCTS</b></p> <p> <b>appliancesonline.com.au</b> Australia's largest online appliance retailer</p>	



Quality kept simple

# EZILoader

## Key Feature Guide

**Big and easy controls**

**A big door**

**Wall mounting kit**

**Front lint filter**

**Front venting**

**Optional rear venting**

**Economical operation\***

**Faster drying**

**Improved safety**

for EZI use even when the dryer is wall mounted

32cm wide opening window door for EZI loading and viewing

EZI to install with the included wall mounting brackets

for EZI access and to encourage safe and economical operation

EZI venting of moist exhaust air away from your laundry walls

with our vent tube kit you can exhaust out of your laundry

dry a 4kg load for 40c, a 5kg load for 50c, or a 6kg load for 60c

dry 6kg in the time that 4.5kg dry on others

the heater element is now located away from the drum

\*Based on 11.6c/kWh - check with your local energy supplier for your local rate

Product .....Date of Purchase .....

Model .....Serial Number .....

Purchaser's Name .....

Full Postal Address .....

Retailer (Shop) .....

Address .....

*Please keep this book and your Proof of Date of Purchase to show the technician if you need service during the warranty period.*

 **From the Electrolux Group. The world's No.1 choice.**  
KITCHEN, CLEANING AND OUTDOOR APPLIANCES

 **appliances online**  
DEC 05 .com.au  
Australia's largest online appliance retailer