

Application & Installation Guide

Cooling Systems

Contents

1.0 Cooling System Basics	8
1.1 Designing to Reject Heat – Liquid Cooled vs. Air Cooled	8
1.2 Heat Rejection and Energy Balance	9
1.3 Energy Balance Components	10
1.3.1 Fuel Energy Input (Q_{in})	10
1.3.2 Work Output (W_{out})	10
1.3.3 Jacket Water (Q_{JW})	10
1.3.4 Atmosphere (Q_{ATM})	11
1.3.5 Lube Oil (Q_{LO})	11
1.3.6 Exhaust (Q_{EXH})	11
1.3.7 Aftercooler (Q_{AC})	11
1.4 Summing Heat Rejection for Each Circuit	12
1.5 Tolerances	12
1.6 Engine Cooling System Circuit Configurations	12
1.6.1 Single Circuit or Combined Circuit Cooling	12
1.6.2 Separate Circuit Cooling	13
1.6.3 Air-to-Air Aftercooling (ATAAC)	15
1.6.4 Aftercooler Condensation and Hot Shutdown Protection	16
2.0 Cooling System Components and Construction	18
2.1 Pumps	19
2.2 Thermostatic Valves	21
2.3 Expansion Tanks	24
2.3.1 Full Flow vs. Remote	25
2.3.2 Bladder-type Expansion Tanks	27
2.3.3 Sizing Expansion Tanks	27
2.3.4 Coolant Piping and Connections	28
2.3.5 Cooling System External Connections	29
2.3.6 Deaeration	31
2.3.7 Venting	33
2.4 System Filling, Draining, and Servicing Considerations	35
2.5 System Management	35
2.5.1 Temperature Control	35
2.5.2 Pressure Control	37
2.5.3 System Temperature and Pressure Limits	39
2.6 Cold Weather Considerations	39
2.7 Extreme Cold Weather Considerations	39
2.8 Jacket Water Heaters	40
2.9 Serviceability and Isolation Valves	42
2.10 System Monitoring	42
2.11 Cooling System Protective Devices	44
2.12 Coolant Level Switches	44
2.13 High Coolant Temperature Switches	44

Table of Contents

3.0 Types of External Cooling Systems	45
3.1 Radiators	45
3.1.1 Vertical Radiator/Cooler	46
3.1.2 Radiator Fans	50
3.1.3 Site Layout for Radiator-Cooled Engines	53
3.1.4 External Cooling System Sizing	54
3.2 Heat Exchangers	54
3.3 Shell and Tube Type.	55
3.4 Plate and Frame Type.	56
3.5 Design Criteria and Considerations	56
3.6 Jacket Water Heat Exchanger Sizing	57
3.7 Aftercooler Heat Exchanger Sizing	58
3.8 Cooling Towers / Evaporative Coolers	59
4.0 Application-specific Cooling Systems	62
4.1 Gen Sets – Hotwells	62
4.2 Gen Sets – Heat Recovery	63
4.2.1 Heat Balance	64
4.2.2 Heat Balance Calculation	65
4.2.3 Standard Temperature Heat Recovery	66
4.2.4 Critical Design Criteria for Standard Temperature Heat Recovery	68
4.2.5 High Temperature Heat Recovery Circuits	68
4.2.6 Expansion Tanks Used in Heat Recovery Circuits.	68
4.2.7 High Temperature Solid Water System	68
4.2.8 Critical Design Criteria for High Temperature Solid Water.	69
4.2.9 High Temperature Water-Steam System	69
4.2.10 Design Criteria for High Temperature Water-Steam	70
4.3 Water Quality and Treatment for Heat Recovery Cooling Systems	71
4.3.1 Standard Cooling Systems	71
4.3.2 High Temperature Cooling Systems	71
4.3.3 Make-up Water	71
4.3.4 Feed Water.	71
4.3.5 Engine Jacket Water	71
4.3.6 Total Dissolved and Suspended Solids	72
4.3.7 Measurement of TDS and Control	72
4.3.8 Alkalinity	73
4.3.9 Total Alkalinity	73
4.3.10 Reserve of Hydroxide Alkalinity	73

5.0 Marine Diesel	74
5.1 Keel Coolers	74
5.2 Jacket Water Aftercooled with Keel Cooler	75
5.3 Separate Circuit Aftercooled with Keel Coolers	76
5.4 Separate Circuit Aftercooled with Keel Coolers and Aftercooler Keel Cooler Bypass	77
5.5 Fabricated Keel Coolers	77
5.6 Sizing of Fabricated Keel Coolers	77
5.7 Marine Gear Heat Rejection	78
5.8 Design/Installation Considerations	80
5.8.1 Coolant Velocity Inside the Cooler	80
5.8.2 Use of Keel Inserts to Improve Local Flow Velocity	80
5.8.3 Direction of Flow through Keel Coolers	81
5.8.4 Bypass Filters	81
5.8.5 Strainers	81
5.9 Packaged Keel Coolers	81
5.9.1 Sizing of Packaged Keel Coolers	81
5.9.2 Location of Keel Coolers on the Hull	82
5.10 Pumps for Keel Cooler Circuits	83
5.11 Venting and Piping of Keel Coolers	83
5.12 Corrosion Inhibitors	83
5.13 Submerged Pipe Cooling	83
5.14 Box Coolers	84
5.15 Seawater Systems	84
5.16 Jacket Water Aftercooled with Heat Exchanger	85
5.17 Seawater Aftercooled	86
5.18 Separate Circuit Aftercooled with Heat Exchangers	87
5.19 Separate Circuit Aftercooled with Heat Exchangers with Aftercooler Seawater Recirculation	88
5.20 3600/C280 Combined Circuit System	89
5.21 Sea Chest	91
6.0 Suction Lines	92
6.1 Sea Valve	92
6.2 Seawater Strainers	92
6.3 Priming	93
6.4 Seawater Pumps	93
6.5 Rubber Impeller Seawater Pumps	94
6.6 Water Ring Seawater Pumps	94
6.7 Centrifugal Seawater Pumps	94
6.8 Seawater Piping	94
6.9 Piping System Materials	94
6.10 Fresh Water Heat Exchangers	95
6.11 Marine Gear Oil Cooler	95
6.12 Stern Tube Lubrication and Cooling	95
6.13 Seawater Temperature	96
6.14 Marine Growth	96

Table of Contents

6.15 Potential Problems	96
6.15.1 Non-reinforced Seawater Pump Suction Hose	96
6.15.2 Internal Hose Deterioration	96
6.15.3 Achieving and Maintaining Seawater Pump Prime	96
6.15.4 Seawater Discharge Through Exhaust System	96
6.16 Corrosion.	97
6.16.1 Galvanic Corrosion in Seawater	97
6.16.2 Dissimilar Metal Combinations to Avoid	97
6.16.3 The Protective Role of Zinc	97
6.17 Contaminants	98
6.18 Series.	99
6.19 General Corrosion.	100
6.20 Erosion	100
7.0 Watermakers, Domestic Water Heaters, Cabin Heaters	101
7.1 Watermaker Controls.	102
7.2 Engines.	104
7.3 When the Watermaker is Far From the Engine	104
7.4 Monitoring Systems/Alarms/Shutdowns.	104
7.4.1 Emergency Systems	104
7.4.2 Jacket Water Pump Connections	105
7.4.3 Auxiliary Seawater Pump Connections.	105
7.4.4 Auxiliary Freshwater Pump Connections.	105
7.5 Central Cooling Systems	106
7.5.1 Advantages of a Central Cooling System.	106
7.5.2 Disadvantages of a Central Cooling System	106
7.5.3 Suggestions for Design of a Successful Central Cooling System	107
8.0 Reference Material	108
8.1 Media List	108

9.0 Appendices	110
9.1 Appendix A.	110
9.1.1 Coolant Flow Calculation and Determining Allowable External Restriction	110
9.1.2 Cooling Circuit Total Heat Load Worksheet	112
9.1.3 Cooling Circuit Flow Rate Worksheet.	113
9.2 Appendix B.	116
9.2.1 Estimating External System Restriction.	116
9.2.2 Example of Straight Length Method of Estimating System Restriction	120
9.3 Appendix C.	121
9.3.1 Coolant	121
9.3.2 Accepted Coolant Components	121
9.3.3 Coolant Recommendations.	122
9.3.4 Testing and S•O•SSM Coolant Analysis	122
9.4 Appendix Appendix D.	123
9.4.1 Other Supplemental Worksheets	123
9.4.2 Heat Exchanger Sizing Worksheet	124
9.4.3 Keel Cooler (Fabricated) Sizing Worksheet	125
9.4.4 Packaged Keel Cooler Sizing Worksheet.	126
9.4.5 Auxiliary Expansion Tank Sizing	127

1.0 Cooling System Basics

In its simplest form an internal combustion engine is an energy conversion device. It is designed to release the chemical energy stored in the fuel, converting it into mechanical work that can then be put to a useful purpose. By using combustion to release the chemical energy of the fuel, the engine becomes a heat source. One of the chief goals of the engine designer is to maximize the conversion of heat into mechanical work. However, as with all such machines, there remains a practical limit to the level of efficiency that is achieved in this conversion. The heat not converted to work is lost into the engine itself.

A simple definition of temperature is “the concentration of heat energy.” The more heat that builds up in a space, the higher the temperature of that space. In the case of the engine, heat is being produced at a rate related to the speed and power drawn by the application. To limit the build-up of heat in the engine is to manage the engine’s temperature, and managed temperatures are key to enabling peak performance from the engine while using less exotic, less expensive materials in its design and manufacture.

1.1 Designing to Reject Heat – Liquid Cooled vs. Air Cooled

The simplest internal combustion engine cooling systems do not involve coolant – they are air-cooled. Rejecting engine heat directly to the surrounding air greatly simplifies its removal from the engine, and eliminating heat exchangers from the heat flow path greatly reduces inefficiencies that can limit system performance. Air-cooled heat rejection is predominantly done through convection, and thus an air-cooled engine design must be optimized for surface area and air flow to be effective. Air-cooled power cylinders often include fins on the outer surface to provide added surface area, and the cooling fans for air-cooled engines are mounted close to the engine to pull air across the hot surfaces.

While certain high-performance engines have been successful as air-cooled designs (examples include many early aircraft engines and the legendary Porsche boxer 6-cylinder), most designs have encountered the fact that air cooling has practical limitations for rejecting large amounts of heat from a limited space. Air’s ability to carry heat is quite small when compared to more dense fluids, such as water; on a heat-per-mass basis water can typically carry four times as much heat as air for the same amount of temperature change. This working temperature rise in the heat rejection fluid is a critical consideration because it is the temperature difference between the hot engine and the cooler heat rejection fluid that causes the heat to flow. In short, modern high-output engines are largely driven to using liquid cooling to manage the higher heat loads involved.

Liquid cooling adds complexity to the cooling system; it is advantageous mainly because of the increased heat carrying capacity of the liquid coolant. Liquid coolant still accepts heat primarily through convection, thus coolant passages must be designed into the engine to create the contact area where the heat passes to the coolant. The coolant must be moved through the engine in some fashion to achieve better heat transfer efficiency and to limit the possibility of overheating the coolant in the hottest parts of the engine. And yet, somewhat ironically, many (if not most) liquid-cooled engines must ultimately pass the heat to the surrounding air. The liquid coolant is used as an efficient heat transfer fluid around the hottest parts of the engine, but the heat must be removed from the coolant to allow it to be “recycled”, returning to the engine to do its job once more. In this manner a steady flow of heat is established, and the rate of flow of heat energy determines the operating temperature of the cooling system.

1.2 Heat Rejection and Energy Balance

With the engine's combustion continually releasing heat, controlling temperature in the engine requires that heat be removed from the engine at a rate similar to that at which it is produced. There are numerous paths by which the heat leaves the engine, and the rate of heat flow in each path depends on the heat flow rate found in the others. Some of the heat energy achieves the engine's main goal, being converted to shaft work. A large amount of heat remains in the exhaust gases and thus exits out the exhaust stack. At the same time, convection and radiation allow heat to dissipate directly from the surface of the engine. The addition of the designed cooling paths through the engine enable us to move heat out of the engine more quickly, thus controlling the total rate of heat flow and the operating temperature.

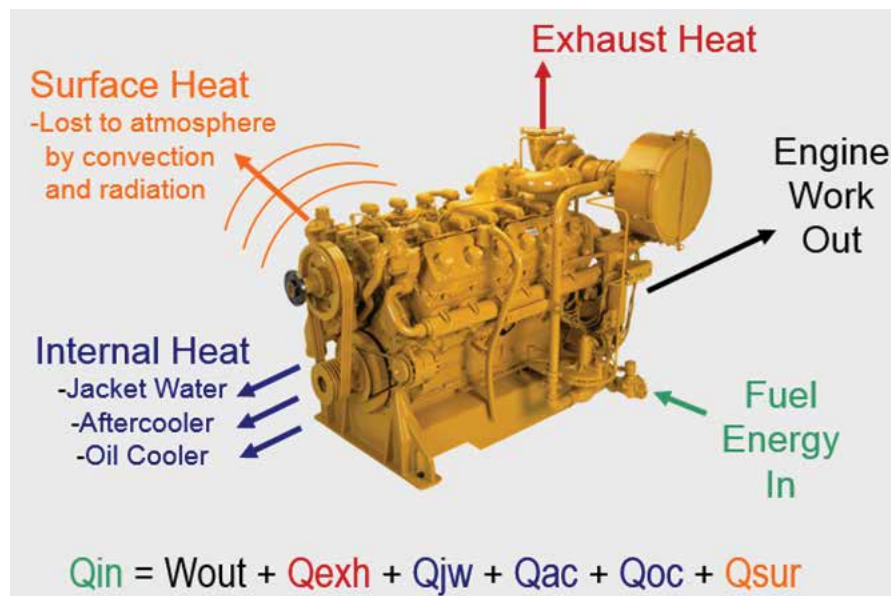

Figure 1.1 — Typical heat rejection paths for an internal combustion engine.

Figure 1.1 shows these paths by which heat can escape the engine. All of the energy released from the fuel must be accounted for along these paths, and this truth can be expressed as the mathematical equation seen at the bottom of the figure. In the equation the letter Q denotes a heat quantity while W is the work done by the engine. From left to right this equation states the fuel energy admitted to the engine is equal to the sum of the mechanical work delivered by the engine and the heat rejected through the exhaust, the various cooling circuits, and from the engine's surface. This equation is referred to as the *energy balance*.

The heat paths that appear in the energy balance equation are a key consideration in the design and development of the engine. They are equally important to the design and execution of the portion of the overall cooling system that must be installed outside the engine to complete the rejection of heat to an external destination. To aid in the completion of this *external* cooling system, the technical data for each engine rating provides numeric values for the heat flow rates on each path. An example of the energy balance data found on a Cat engine rating technical data sheet is shown in Figure 1.2.

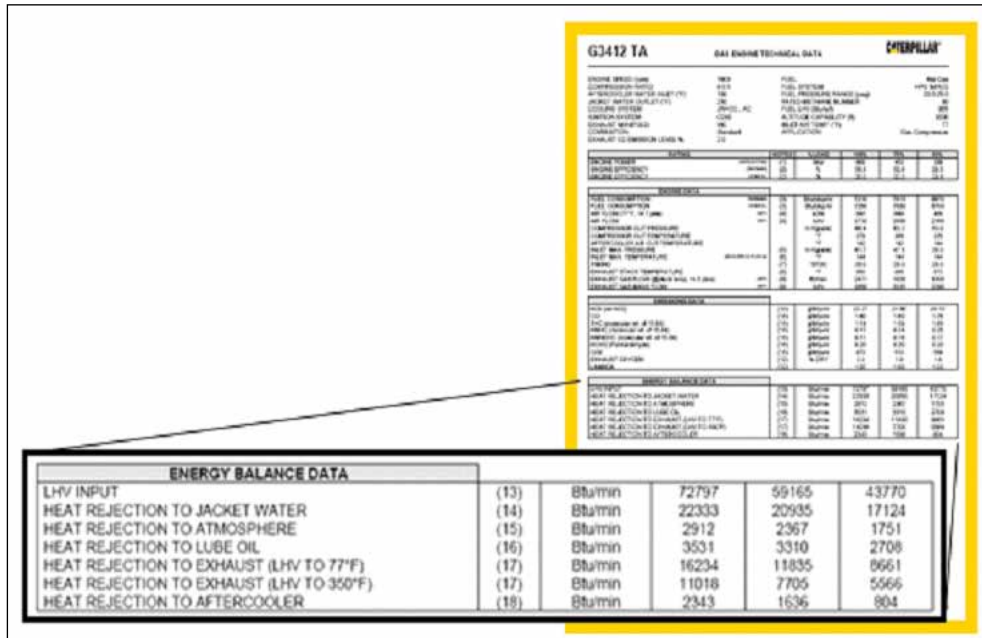

Figure 1.2 — Example of energy balance data, as shown on a technical data sheet for a Cat® engine.

1.3 Energy Balance Components

Let's look at each component of the energy balance to better understand what it is and how it is presented on the technical data sheet. Note that each heat value is shown with units of energy per unit of time, indicating the constant flow of heat for each under steady-state operating conditions.

1.3.1 Fuel Energy Input (Q_{in})

This is the usable energy of the fuel that is consumed by the engine. The term "usable" is included here to indicate that some of the total energy present in the fuel will be unavailable for use by the engine. Because one byproduct of combustion of a hydrocarbon fuel is water vapor, a portion of the fuel's energy is lost in to the *latent heat of vaporization*, the heat required to convert water from a liquid to a gas. For some fuel types the usable portion of the fuel's energy is described as the *lower heat value (LHV)* of the fuel (as seen in the energy balance in Figure 1.2).

1.3.2 Work Output (W_{out})

This is the power produced by the engine and used by all of the loads connected to the engine in some fashion (includes mechanically, electrically, and hydraulically driven equipment). The work output of the engine doesn't appear in the energy balance section of the technical data -- it is the power listed further up the page. In some cases a unit conversion is needed to put this power quantity in common terms with the heat rates listed for the other portions of the energy balance (e.g., for English units convert from horsepower to Btu/min).

1.3.3 Jacket Water (Q_{JW})

This is the heat transferred to the main coolant flow in the engine. This coolant is circulated through passages cast into the engine's cylinder block and cylinder heads, most commonly referred to as the "cooling jacket", hence the term *jacket water*.

1.3.4 Atmosphere (Q_{ATM})

This is the heat that escapes to the surroundings from the surface of the engine. As mentioned earlier there are two heat transfer mechanisms involved in this heat flow:

- convection, in which the hot surface of the engine warms the surrounding air; and
- radiation, in which the engine's surface loses heat to the surroundings as infrared energy.

Both mechanisms are highly dependent upon the site conditions and thus this quantity has the largest variability of all the heat flows listed in the technical data.

1.3.5 Lube Oil (Q_{LO})

This is the heat accumulated in the lubricating oil as it is passed through the critical bearing surfaces inside the engine. Cooling is a second important function performed by the oil, in addition to its job as a lubricant. Certain engine designs specifically use the lube oil as a coolant for areas where it is impractical (or impossible) to design a way to use the JW coolant to do the job. Areas such as turbocharger bearings and the piston's crown may be oil-cooled.

1.3.6 Exhaust (Q_{EXH})

This is the heat retained in the exhaust gases as it leaves the engine. This can be such a large amount of the total heat lost during the engine's operation that some installations will seek to recover this heat through the use of an exhaust mounted heat exchanger. The amount that can reasonably be captured in this manner depends on the temperature difference between the exhaust and the recovery medium (often another coolant loop) and the time the two spend in the heat exchanger. However, a heat exchanger that provides a longer contact time will increase the exhaust backpressure (which has a direct impact on engine performance), making such a heat exchanger difficult to implement. Two exhaust heat rejection quantities are often listed on Cat® engine technical data:

- "LHV to (25°C) 77°F" represents the full heat quantity present for the temperature difference of the exhaust flow from the exhaust stack temperature to an approximated ambient air temperature of (25°C) 77°F (English units example).
- "LHV to (177°C) 350°F" represents an estimate of the recoverable heat present for a temperature difference from the exhaust stack temperature to an approximated recovery medium temperature of (177°C) 350°F (English units example).

1.3.7 Aftercooler (Q_{AC})

This is the heat transferred in the engine-mounted heat exchanger known as the aftercooler. An *aftercooler* is present on nearly all turbocharged engines. Its job is to remove the heat added to the incoming combustion air during its compression in the turbocharger. In this manner the aftercooler simultaneously decreases the air temperature (to limit detonation) and increases the air density (a denser air/fuel charge enables greater power from a given engine displacement). Some engines may use a two-stage aftercooler, an arrangement that runs the high temperature air first through a heat exchanger stage on the high temperature jacket water cooling circuit, then the same air is passed through a second stage on the lower temperature auxiliary circuit, improving performance of the aftercooler. For such arrangements, two values are displayed in the engine technical data, one for each stage of the aftercooler.

1.4 Summing Heat Rejection for Each Circuit

Each cooling circuit will need to pass the heat it gathers to an external heat sink of some sort. Be it a radiator, mechanical chiller, or marine cool water source, the temperature of the heat sink must be lower than that of the coolant in the circuit for the flow to proceed out away from the engine. Cooling system types will be covered later in this guide; however, it is important to note that the heat flows described above can be arranged in many different ways on a given engine. The engine rating technical data sheet should indicate the cooling system configuration to guide you on how to sum up the individual heat loads to a full circuit total. Some calculations, such as those for two-stage aftercooling, require a proportioning value to determine the total heat load passed to each of the two circuits. The calculation details should also be available in the technical data or project guides for that engine rating.

1.5 Tolerances

Each heat rejection path has variabilities associated with the amount of heat that will pass down that path on a given site. For this reason, all of the values displayed on the engine rating technical data sheet have tolerances associated with them. Always include the tolerances when summing heat loads for purposes of sizing a cooling system, with the goal being to cover the worst-case scenario for each source of variability. For heat quantities, this means you will add the tolerance amount to the nominal value to ensure your calculations are based on the largest heat load deemed likely for that cooling circuit. The appropriate tolerances for each heat load should be identified in the footnotes assigned to each individual heat value on an engine's technical data sheet.

Heat recovery applications form an exception to this rule. Because the heat captured by the recovery system is used for other processes external to the engine it can cause problems to state values higher than the nominal numbers. For sizing the heat exchanger it is necessary for the designer to consider the full potential heat load (with the tolerances included), but when reporting the heat generating capability of the engine to the larger installation the nominal numbers should be used, or for an even more conservative reference consider using the nominal less the tolerance. In this manner the engine will always be able to fulfill the heat transfer rates promised to the external systems.

1.6 Engine Cooling System Circuit Configurations

The discussion on energy balance earlier in this guide raised awareness of the various sources of heat on the engine. On an actual engine those heat paths must be represented by actual components designed to capture and carry away the heat from each area. To simplify the connections to the external cooling systems those components can be connected together to form circuits, defined sequences of the components involved. The cooling circuit configurations available for a given engine model will vary, with the most commonly seen described below.

1.6.1 Single Circuit or Combined Circuit Cooling

The examples shown above focused only on a single cooling circuit for simplicity's sake. In actual practice many engines use multiple cooling circuits. A single circuit cooling system may be found on a naturally aspirated (NA) engine, with no turbocharger and thus no aftercooler to be placed on a separate circuit. A turbocharged engine that cools the aftercooler with jacket water (a jacket water aftercooled, or JWAC engine) also does not require a separate circuit since the heat loads use a common coolant flow. A *combined circuit* arrangement can be created by operating the jacket water system as a closed loop that is cooled by the aftercooler flow. In isolating the jacket coolant, only one external cooling flow results.

Both the single circuit and combined circuit configurations produce a very simple cooling system setup. With all heat loads on a common circuit these configurations require only one coolant path to the external cooler, and thus can use a single-core cooler for the external portion of the circuit.

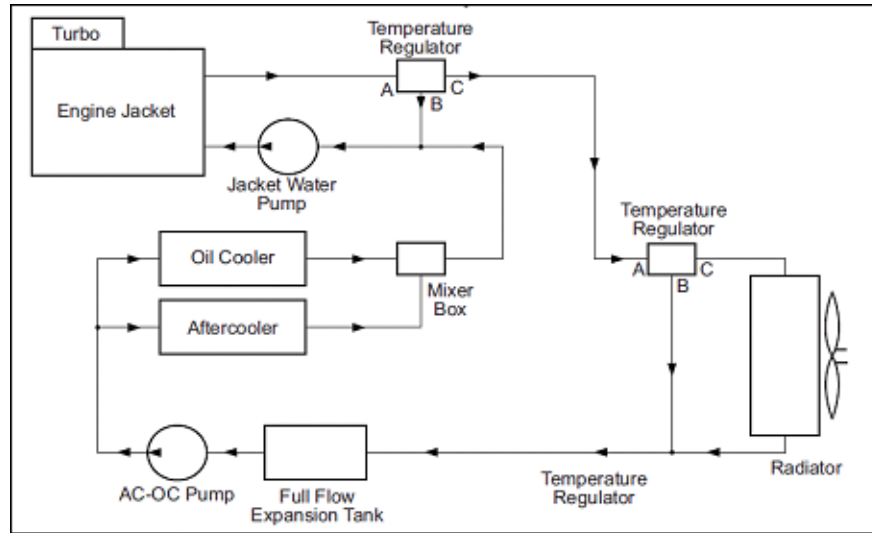

Figure 1.3 — An engine cooling system schematic for combined-circuit cooling.

1.6.2 Separate Circuit Cooling

The most commonly seen configuration for turbocharged engines is the *separate circuit* arrangement, sometimes abbreviated as SCAC for “separate-circuit aftercooled.” In a separate circuit system the aftercooler is moved to a circuit distinct from that of the jacket water, which allows the two circuits to be regulated to different temperatures. Running the aftercooler at a much lower temperature than the jacket water allows the intake charge temperatures to be lowered. The greater air density and reduced charge temperature that result both contribute to enabling higher engine power levels. Separate-circuit cooling is a necessity on gas engines. The lower temperature of the air-fuel mixture delivered to the cylinders is essential to avoiding detonation, one of the key limiting parameters for gas engine performance.

The separate circuit configuration does require one circulating pump, one thermostat, and one external cooler core for each circuit. If the engine shown above as a combined circuit arrangement were reconfigured to a separate-circuit configuration, it would appear as shown in Figure 1.4.

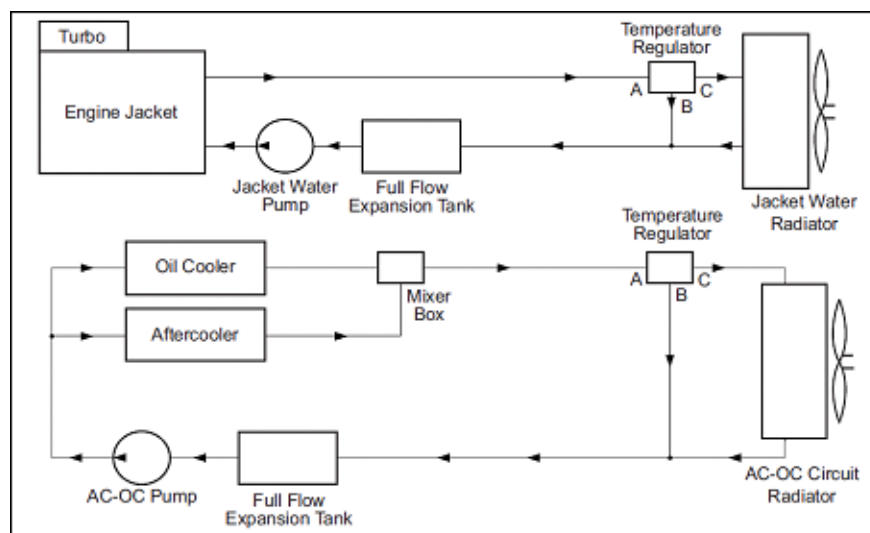

Figure 1.4 — An engine cooling system schematic for separate-circuit cooling.

Cooling System Basics

Note that the sequence of the heat sources on the engine may be changed to suit the differing needs of different applications. While this diagram shows the oil cooler and aftercooler in parallel on the low temperature circuit, many engine designs include the oil cooler as the first heat load on the high temperature circuit with the aftercooler as the only heat load on the low temperature circuit.

Other common two circuit configurations move the oil cooler from the high-temp to the low-temp circuit. Elevated jacket water temperatures may be found in heat recovery systems, such as combined heat and power, in which the higher coolant temperature helps increase the heat energy captured by the external systems. Higher jacket water temperatures may also be used on corrosive gas sites, including landfills and sour gas fields, where the increased jacket water temperature helps to prevent corrosive blowby fumes in the crankcase from condensing into acids in the oil fill in the sump. Large concentrations of acid forming in the sump can circulate with the lube oil, giving access to bright metal components that could be damaged by them. In each case the regulated temperature for the cooling circuit is higher than is recommended for the lube oil and can lead to premature breakdown of the oil. Moving the oil cooler, the lower temperature circuit addresses this problem.

Another variation of the separate circuit configuration arises when two-stage aftercooling is used on the engine. The air temperature leaving the turbocharger's compressor is well above the regulated temperature of the jacket water circuit. Thus the first core section of the aftercooler can be included on the jacket water circuit, enabling part of the total heat load to be passed into the high temperature circuit. This approach substantially lowers the total heat load that must be carried by the low temperature circuit, which simultaneously improves control of the charge air temperature and reduces the size requirement for the external cooler core on the low temperature circuit. Two-stage aftercooling is a core technology for enabling the very low NO_x emissions of newer lean-burn engine designs. If the engine in the previous examples were configured to take advantage of two-stage aftercooling, it might appear as shown in Figure 1.5.

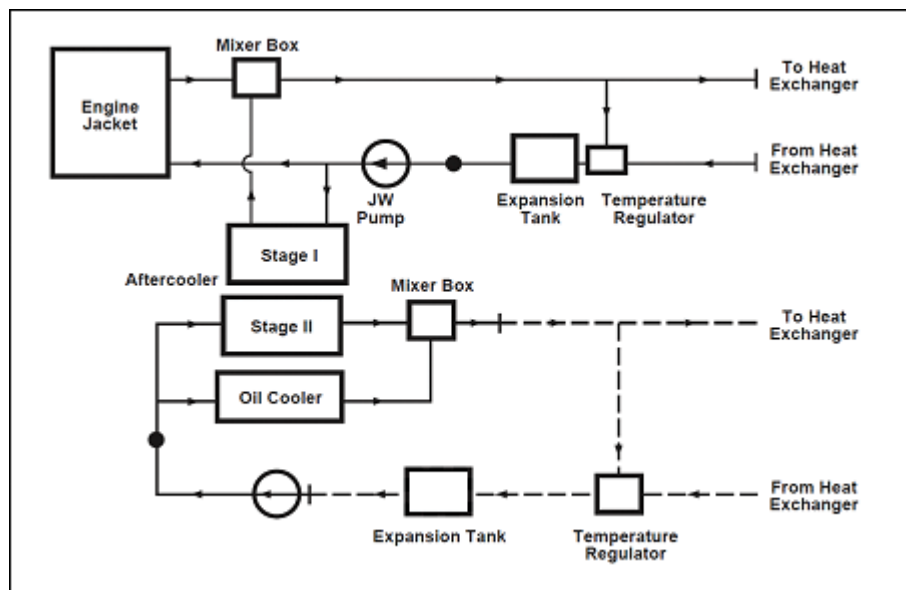

Figure 1.5 — An engine cooling system schematic using two-stage aftercooling.

1.6.3 Air-to-Air Aftercooling (ATAAC)

A special case of separate circuit cooling seeks to use the best properties of liquid- and air-cooled systems on the same engine. The engine's jacket water system is retained as it is found on other separate-circuit configurations but the engine-mounted, liquid-cooled aftercooler is replaced with a direct air-to-air heat exchanger, typically installed off-engine. This is done in instances where high ambient air temperatures are expected to limit the ability to achieve the required temperature of the coolant provided to the engine's aftercooler. By eliminating the liquid coolant circuit, one intermediate step of the heat exchange is removed. This allows only one step of temperature difference (approach temperature) instead of two, allowing the combustion intake air to be cooled to a temperature much closer to the ambient air temperature than would be possible with the liquid-cooled circuit. The layout of an ATAAC arrangement is shown in Figure 1.6.

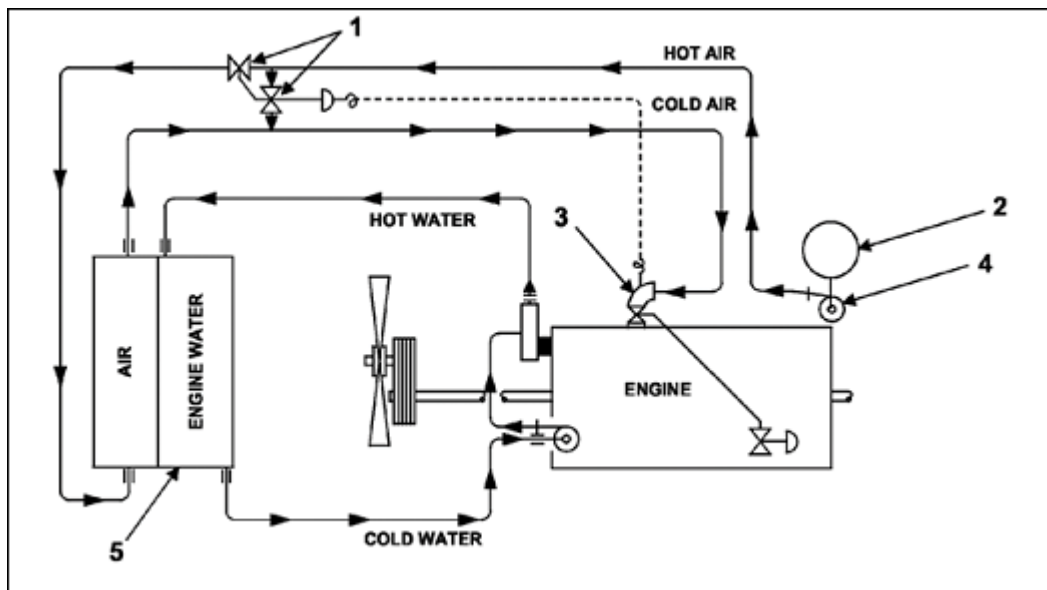

Figure 1.6 — A typical air-to-air aftercooling system. Air enters at the air cleaner (2), is boosted by the turbocharger (4), and then is routed to the air-to-air core of the cooler (5). Temperature measurement at the engine air inlet (3) allows control of the resulting air temperature via a regulated bypass valve (1) on the external air lines.

For an ATAAC configuration, instead of pumping liquid coolant from the engine to an external cooler, the combustion intake air itself is sent to an external cooler section. Such a configuration does come with some limitations. Consider that:

- It is more difficult to regulate the actual combustion intake air temperature on an ATAAC engine than it is on a conventional liquid-cooled arrangement. This makes it even more important that the engine management system (if the engine is so equipped) monitor variations in the achieved intake manifold air temperature (IMAT). These measurements are used to make any necessary adjustments to the injection/ignition timing or air/fuel ratio to maintain the engine's performance and emissions.
- Having the combustion air cooled directly by the ambient air can create challenges for operating the engine in an arctic environment – very cold intake air temperatures can have a significant impact on combustion. Automated controls become necessary to compensate for this. A thermostatically-controlled valve that allows some air to bypass the cooler provides temperature control of the intake air similar to the liquid-cooled arrangement. Other options, such as variable speed fans or adjustable shutters on the cooler, can also be used to offset the effects of the extreme cold environment.
- Routing the intake air from the turbocharger to an external cooler adds restriction to the air flow path. Because the nominal engine performance is based on a design air mass flow rate, restriction can affect the performance envelope of the turbo, essentially decreasing the altitude capability of the engine if the added restriction is excessive. The maximum allowable pressure drop in the air flow path should be available in the engine's technical data.

Note: Not all engine designs are easily adapted to ATAAC. While ATAAC is available from the factory for some engine models, the complexity of the factory configuration on others may preclude being able to modify them to an ATAAC configuration. ATAAC is specifically ruled out for larger gas engines that mix the fuel and air before the turbocharger due to the very large volume of a combustible fuel-air mixture that would reside in the air piping and cooler core.

1.6.4 Aftercooler Condensation and Hot Shutdown Protection

Humid intake air is not unusual for many climates and for such sites cooling the air flow into the engine means a great deal of water may condense in the air path of the aftercooler core. The relatively low cooling temperatures of an ATAAC design only serve to increase the potential for condensation, enough so that provisions to remove the water from the aftercooler core and piping must be included in the design. As an example, a G3516 LE Engine may produce up to 114 liters (30 gallons) of water a day working in a 32°C (90°F) application.

This water can be easily drained if the intake air enters the bottom of the core on one side and exits high on the opposite side. This routing of the air flow gives the best potential for gathering the condensation across the entire core. An automatic drain valve should be plumbed into the bottom side of the core, opposite the entrance of the intake air, to make it possible to pull this water out of the system for disposal. Note that function of the valve requires free movement – the drain valve should not be allowed to freeze in cold temperatures.

To capture any last droplets before the air enters the cylinders, condensate traps should be installed in the intake piping close to the engine intake manifold. The design of a condensate trap is shown in Figure 1.7; it forces the air flow to quickly change direction to throw the heavier water droplets into a wall of the trap where they are collected and drained through a float valve. As with all components of the air path, the condensate trap must be sized and designed so that its pressure drop is not excessive.

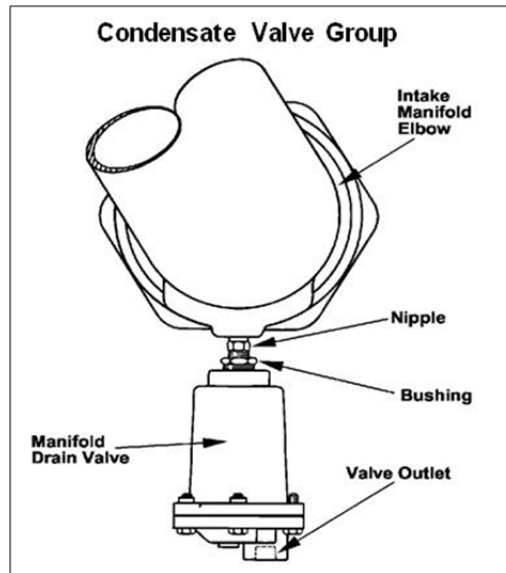

Figure 1.7 — A condensate valve group.

The cutaway piping at the top is the air path showing the large direction change used to separate the condensed water droplets from the air flow. The valve group at the bottom is designed to automatically release accumulated water from this air path trap. This particular trap is used on ATAAC arrangements offered for G3300 and G3400 Engines.

Hot shutdowns (usually the result of an operating fault) are concern for aftercooled engines. The large volume of pressurized air in the core will seek an exit at shutdown and can cause the turbocharger to spin backwards ("windmill") as it flows back up the intake path. Spinning without lubrication can be damaging to turbo bearings. Turbo oil accumulators can take the place of a postlube cycle under fault conditions, providing a pressurized oil feed to the bearings during windmilling. Accumulators may be standard equipment on some engine models.

2.0 Cooling System Components and Construction

The previous section addressed the basics of what is needed to create an effective cooling system for a number of different engine configurations and applications. In this section we will focus on details pertaining to the components in the system. Consider this basic diagram of a two-circuit cooling system.

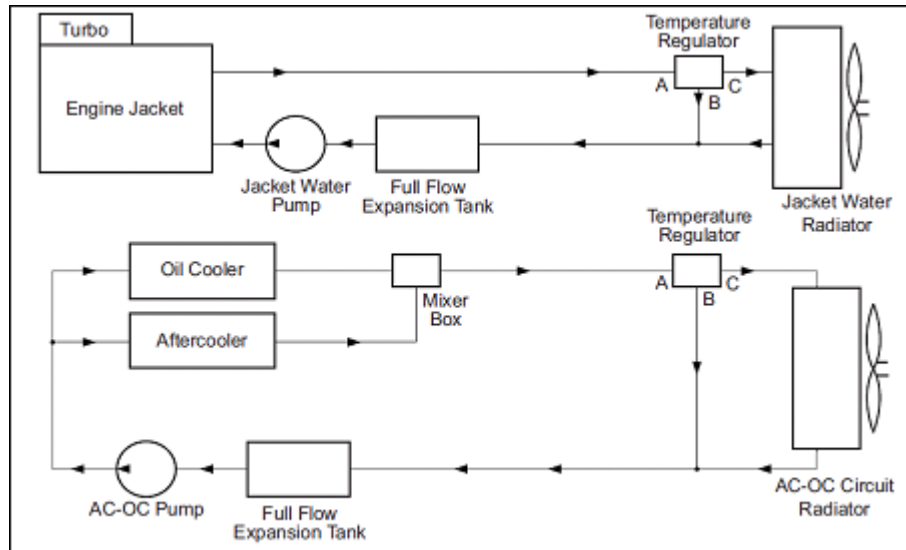

Figure 2.1 — A schematic of a two-circuit engine cooling system.

In this diagram, the system components other than the primary heat sources (engine jacket, oil cooler, and aftercooler) are:

- Circulating pumps to move coolant through the circuits
- Thermostatic valves to regulate the circuit operating temperatures
- Expansion tanks to manage thermal growth of the coolant
- Piping systems to connect the components into flow circuits
- Venting systems to deaerate the coolant flow
- External radiators or heat exchangers to reject heat from the coolant

Let's start with the components close to the engine and move outward into the larger installation to build an understanding of each of the components and how they interconnect to complete the system.

2.1 Pumps

To maintain the proper operating temperatures within the engine the coolant must be circulating; moving coolant is the job of the circulating pump. To do this the pump raises the pressure of the coolant to cause it to move away from the pump outlet (discharge) and through the rest of the cooling circuit. As the coolant moves through the circuit, friction against the walls of the cooling passages adds resistance to the flow of the coolant, gradually drawing down the pressure provided by the pump. When the coolant has traveled through the entire circuit, it returns to the pump inlet (suction) at a much lower pressure than when it started. The pressure increase across the pump, from suction to discharge, is termed the *pump rise*, one of the core properties of the cooling circuit.

The coolant pump will need to provide enough pressure rise to offset the restriction to flow posed by the entire circuit, the on-engine and off-engine components all together. For this reason factory-provided cooling pumps will have pressure rise capability well beyond the restriction levels posed by the on-engine coolant path alone. For engines equipped from the factory with an engine-driven cooling pump, Cat cooling system documentation incorporates both the pump rise and the restriction internal to the engine to produce curves of *allowable external restriction* to flow. By subtracting the internal restriction from the pump rise, these curves display the remaining pump pressure available to drive the coolant through the cooling system components installed between the engine outlet and pump inlet. The allowable external restriction curves are found in the Technical Marketing Information database (TMI) and other related primary engine data sources (such as Gas Engine Rating Pro for gas engines). Because an engine-driven pump's capability is related to its turning speed, the pressure-flow relationship varies with engine speed and thus these curves show traces for several engine speed increments. An example of the allowable external restriction curves is shown in Figure 2.2.

As stated above, the pump rise, the circuit's restriction to flow, and the resulting coolant flow rate are related. Similarly, the circuit heat rejection, temperature rise, and coolant flow rate are also related. From this you should understand that design choices that alter one or more of these parameters will affect the others in a direct way. In fact, the interrelatedness of these parameters forms the basis for a methodical approach to circuit design based on calculations of the flow-restriction relationship for the design being considered. For more information on these system flow-restriction performance calculations, please review Appendix A.

Most engine-driven coolant pumps are an impeller-type design, meaning they have partially open vanes that are rotated in an enclosed housing. The impeller vanes serve as paddles within the pump housing, pushing the coolant as they rotate, thus the coolant gains both pressure and velocity. Being a centrifugal design, as the coolant rotates centrifugal force drives it to the outside of the housing. Some pump designs gain a more efficient transfer of energy from the impeller to the coolant through the use of curved vanes and a scroll-shaped housing; however, even straight vanes in a symmetrical housing can be effective in driving the coolant through the system.

Cooling System Components and Construction

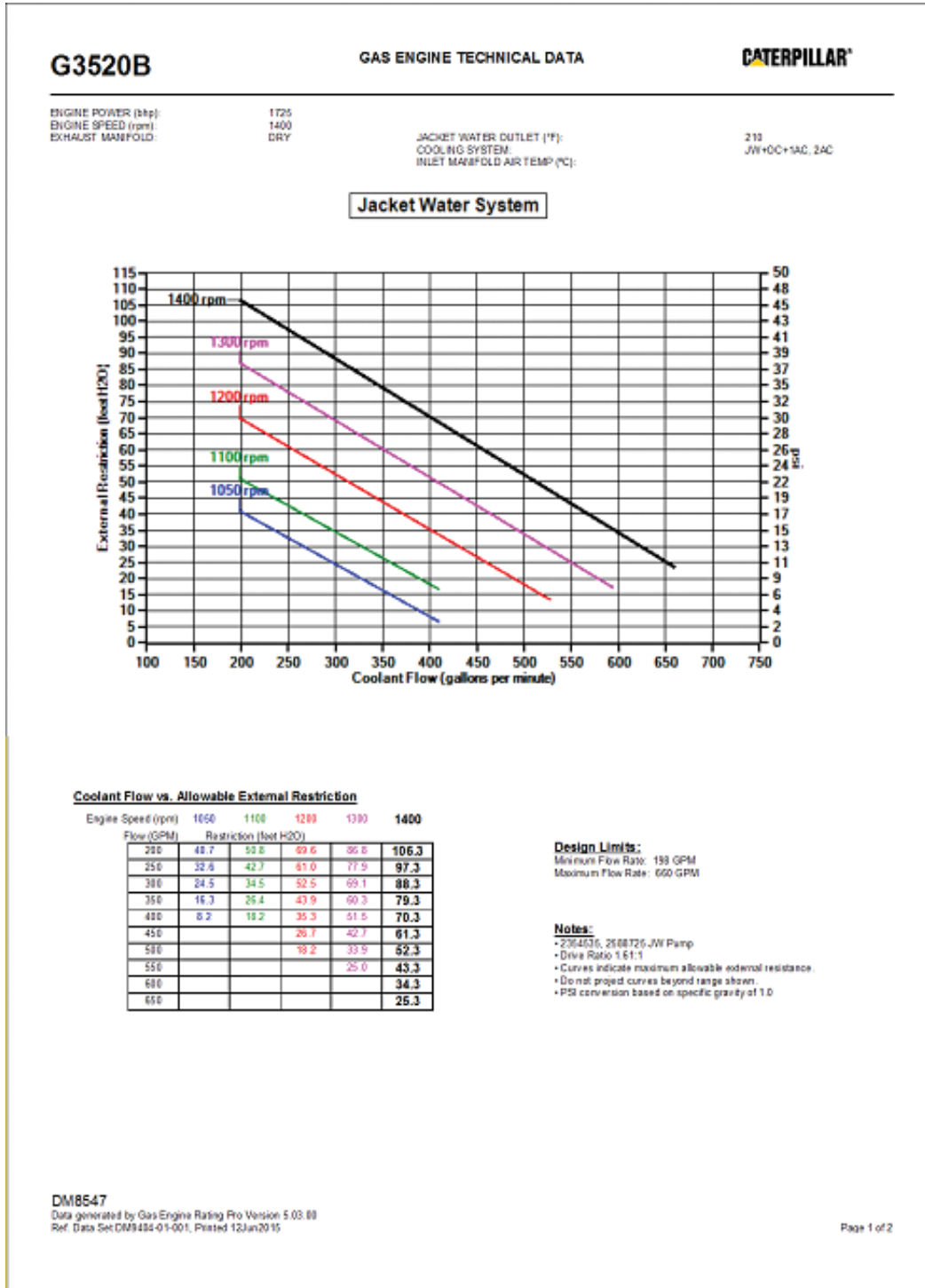

Figure 2.2 — An example of the allowable external restriction curves published for a Cat engine with engine-driven pumps.

The primary advantage of the impeller-type design is it is simple and effective. There is no need to resort to the complexity of a positive displacement design when the impeller does the job well. A disadvantage of the impeller design is the risk of cavitation. Just as the impeller vanes increase the pressure in the coolant pushed ahead of each vane, they induce a drop in pressure immediately behind each vane. If the pressure drop is too large, small bubbles of vapor can briefly form on the vanes, collapsing as the pressure of the surrounding fluid overcomes the internal pressure of the bubbles. This formation and collapse of bubbles produces a cyclic hammering on the surface of the impeller, which over time can cause pitting and other fatigue-related damage to the pump. Left for longer periods, pump failure can result. The solution to the risk of cavitation is to ensure there is sufficient positive static pressure at the pump inlet. The minimum pressure required at the pump inlet to ensure cavitation does not set in is called the *net positive suction head (NPSH)*. The application information for each engine should include minimum static pressure values for each coolant pump installation to satisfy this NPSH requirement.

For engines that do not include engine-driven pumps, off-engine pumps must be provided to circulate the coolant. These often are electrically driven, and yet if the pump itself is a centrifugal design, many of the same behaviors and installation concerns noted above will apply to those pumps as well. Much less common in today's engines is the cooling circuit that uses no circulating pump. A *convective* system relies on the change in buoyancy of the coolant as it is heated by the engine. Coolant admitted near the bottom of the engine rises toward the top as it gains heat. The upward movement of the coolant increases pressure at the engine outlet, while at the same time decreasing pressure at the inlet, resulting in a steady circulation through the cooling circuit. The low velocity of a convective cooling system limits the amount of heat it can carry, thus its use is generally restricted to engines with relatively low specific power output. Another variant on this theme is the *ebullient-cooled* engine, which actually incorporates nucleate boiling of the coolant to increase the heat rejection from the engine to the coolant. A challenge of the ebullient-cooled design is to avoid having the boiling transition from nucleate to film boiling. Such a change can lead to a layer of vaporized coolant insulating the hot metal surface from direct contact with the coolant, diminishing the heat transfer in that zone, and resulting in higher temperatures in the metal. While these designs do eliminate the power consumption of the circulating pump, they forfeit control of the circulation of the coolant and thus are more challenging to maintain at the optimal cooling condition than a forced-circulation system.

2.2 Thermostatic Valves

Keeping the engine at or near the target operating temperature requires a temperature control element that can balance the heating of the coolant in the engine with the heat rejection of the external cooler. This is the function of the thermostatic valves or thermostats (often abbreviated as "stats"). The engine thermostats use temperature-driven actuation of a valve to mix heated coolant from the engine outlet with chilled coolant coming from the external cooler. As indicated earlier in this guide, the location of the thermostat installation at the engine inlet or outlet end of the coolant bypass line plays heavily in the actuation temperature selected for the thermostat.

Most engines, large and small, use a fairly common design for the temperature control element of the thermostat. The wax pellet thermostat design dates back to the 1930s and yet is so widely used because it cost-effectively accomplishes the task required of it, to reliably regulate the engine's cooling system temperature. Wax thermostatic elements place a wax pellet inside a sealed chamber, using the volume change of the wax transitioning from solid to liquid to actuate a flow diverting valve. As the wax is subjected to higher temperatures, its continued melting will drive the valve further until it reaches the fully-open position. A spring provides the closing force to drive the valve back to its original position when the cooled wax returns to its solid state.

Cooling System Components and Construction

The actuation temperature of the wax thermostat is determined by the formulation of the wax in the pellet. It is advantageous to select a target nominal operating temperature that is slightly below the fully-open temperature to give the thermostat some ability to recover to the target temperature in the event of a temperature overload event.

The piece that integrates the thermostat into the coolant path on each engine is the thermostat housing. Depending on the flow requirements of the individual cooling circuit, a thermostat housing may support a single wax bulb element or it may contain many. Multiple element housings are typical on larger engines to support the increased flow required by those engines. Details of the function of a wax pellet thermostat and its fit into the regulator housing can be seen in Figure 2.3.

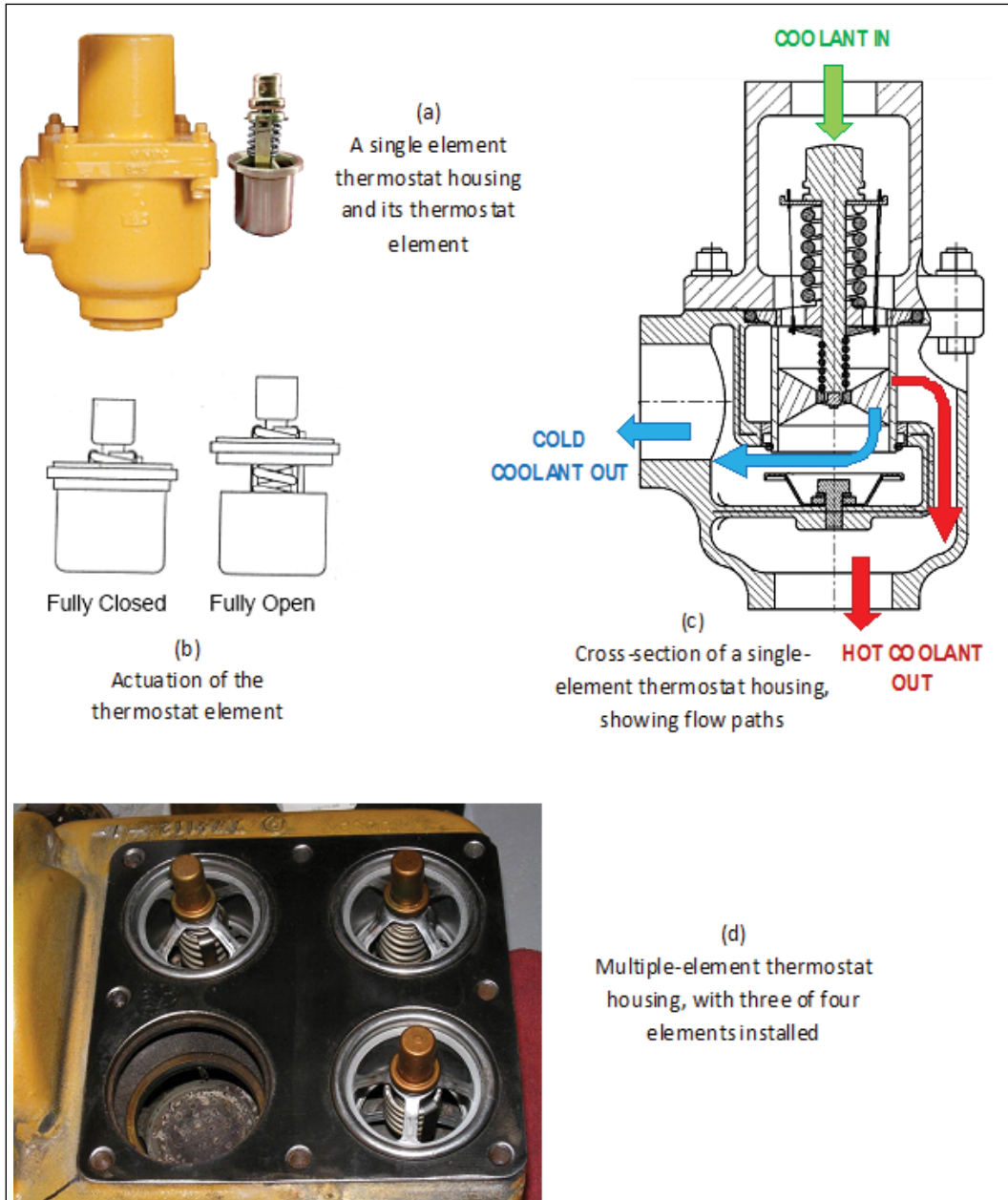
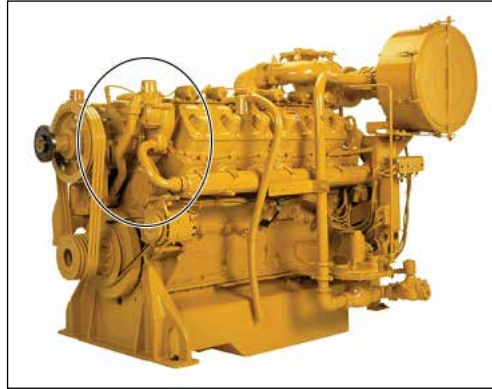
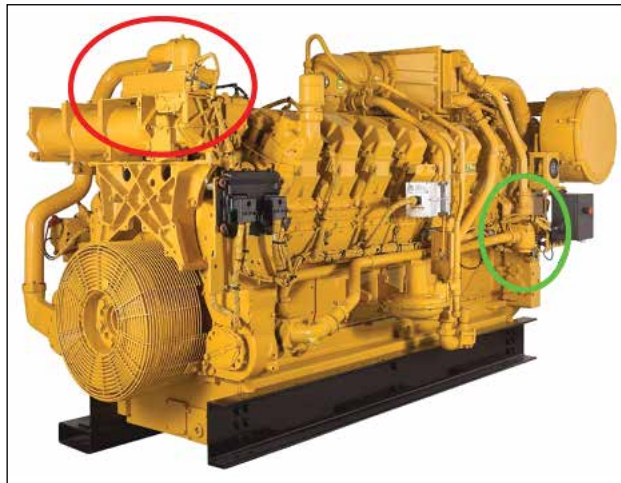

Figure 2.3 — Coolant thermostats and housings, with details of their installation and operation.

Cooling System Components and Construction



The location and configuration of the thermostats on a given engine may depend on the engine model and the particular circuit on the engine. The G3412 above uses a single-element thermostat on the jacket water outlet of each cylinder head (see thermostat housing and bypass line in the red circle) and no thermostat on the aftercooler circuit.



The 3500-Series Engine above uses a four-element thermostat to regulate the jacket water circuit (red circle on left side of photo) and a single-element thermostat housing for the separate-circuit aftercooler (green circle on right side of photo). In each case, these thermostats are mounted on the engine, with their location and size driven by the connections and flow volume of the cooling circuit they serve.



The 3600-Series Engine above uses (shipped loose) four-element thermostats on each circuit that are integrated into the site piping system by the designer/installer. In this image the bypass line brings the coolant down from the top-mounted engine outlet to the thermostat. Cold flow returns directly to the pump inlet at bottom; hot flow is routed to the cooler (circled area) before returning to the pump inlet on the right-hand leg of the pipe tee. Mixing of hot and cold flows occur in the pipe tee.

2.3 Expansion Tanks

Each engine will experience a change in temperature as it is started and brought to a condition to begin powering a process. That change in temperature produces a related change in the space occupied by the coolant as it warms up. This change in volume with temperature is referred to as thermal growth. Because the engine's cooling system is operated as a closed system, space must be included to accommodate thermal growth of the coolant. This is the primary job of the expansion tank.



Figure 2.4 — An expansion tank on top of the cooler for a G3304 NA Gas Compressor Engine package. Only one tank is present because the engine is naturally aspirated, which means it will only have the jacket water circuit to cool. The other sections of the cooler are used by the compressor.

An expansion tank is included in each coolant circuit to provide space for the expanding coolant without forcing some portion of it out of the system. Because the growth of the coolant is proportional to the amount of coolant present, the sizing of the tank is stated as a percent of the total system fluid volume. Please refer to the section on “Sizing Expansion Tanks” for more information.

The expansion tank typically does much more than add volume to the system. It may also serve as the high point in the venting system or as part of a fluid column used to maintain positive static pressure on the circulating pump’s inlet. It is also a typical location for filling the system with coolant and, as a result, is often where a pressure cap is incorporated into the system to regulate the cooling system operating pressure. How each of these functions is accomplished in each cooling system design determines the size, shape, location, and interconnection of the expansion tank.

2.3.1 Full Flow vs. Remote

Placing the tank directly in the line of flow of the coolant makes it a *full flow* expansion tank. Moving the tank to a location out of the line of flow of the coolant makes it a *remote* tank. Both designs are common and each brings its own considerations for design and installation. Illustrations of full flow and remote tanks appear in Figure 2.6. Note in each case the expansion tank is mounted as the high point of the system because it is used for all of the functions mentioned earlier: expansion volume, venting/deaeration, pump positive pressure, and filling/pressure regulation.

Placing an expansion tank in full flow service requires attention to some details specific to that case. In order to allow for deaeration, the tank must be large enough to slow the coolant flow velocity in the tank. This must happen for the bubbles to rise out of the liquid flow. Sizing the tank too small can actually contribute to putting air bubbles into the coolant flow; the tank should not exchange its full volume any more than 50 times in a minute. A design target of no more than 30 exchanges per minute with proper baffling in the tank will help to maximize the tank’s performance for deaeration, even with the coolant fill at its lowest permissible level.

Being out of the direct flow path, a remote expansion tank serves as an overflow reservoir for the system. As a static volume it does not require the oversizing for flow deceleration that is needed in the full flow tank. However, some provisions for deceleration must be designed into the coolant path at the location where the venting system connects for best deaeration performance.

As seen in Figure 2.6, the full flow tank provides positive static pressure to the pump inlet when it is installed ahead of the pump in the flow circuit. For a remote tank this is accomplished by placing a shunt line between the tank and the pump inlet. In each case there must be a connection to the system from the bottom of the tank to prevent coolant from getting trapped in the tank with no way to return. Note that all expansion tanks, full flow, or remote, are part of the pressurized cooling system; hence their construction must be sturdy enough to support the operating pressure of the system. Please also consider the volume of liquid they will contain as the structure must be robust enough to support the weight in an environment that is likely to include exposure to vibration.

Most radiators include expansion volume in their top tank design (the “top tank” is the header at the top of the radiator). Check that the volume provided is adequate for your system volume. For some installations where the internal restriction of the radiator core limits the static pressure exerted on the pump inlet, a shunt line may be included in the interconnect piping between the radiator and the engine. A shunt line for a close-mounted radiator may appear, as shown in Figure 2.5. If the top tank volume is not sufficient for such a system, a remote expansion tank can be added to the system. For such a design the remote tank should serve as the primary expansion volume with interconnecting lines between the radiator top tank and the expansion tank to ensure this is the case. The remote tank cannot be placed below the radiator top tank.

Cooling System Components and Construction

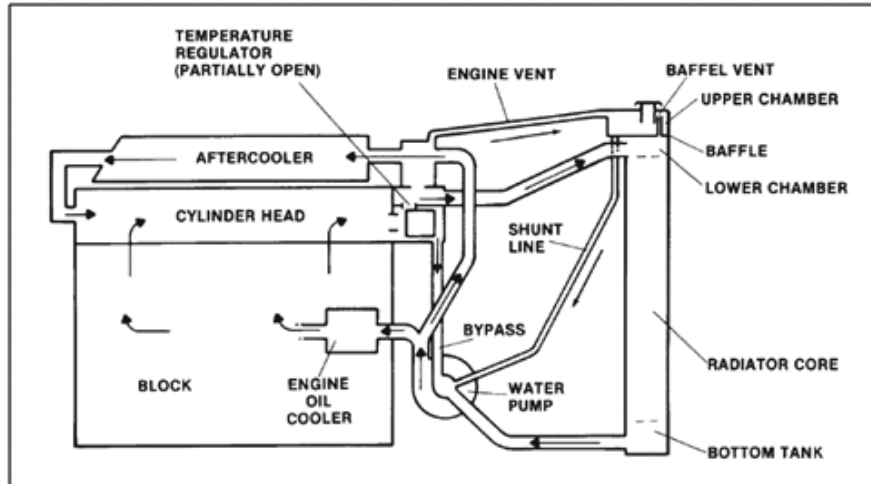

Figure 2.5 — A close-mounted radiator installation that includes a shunt line.

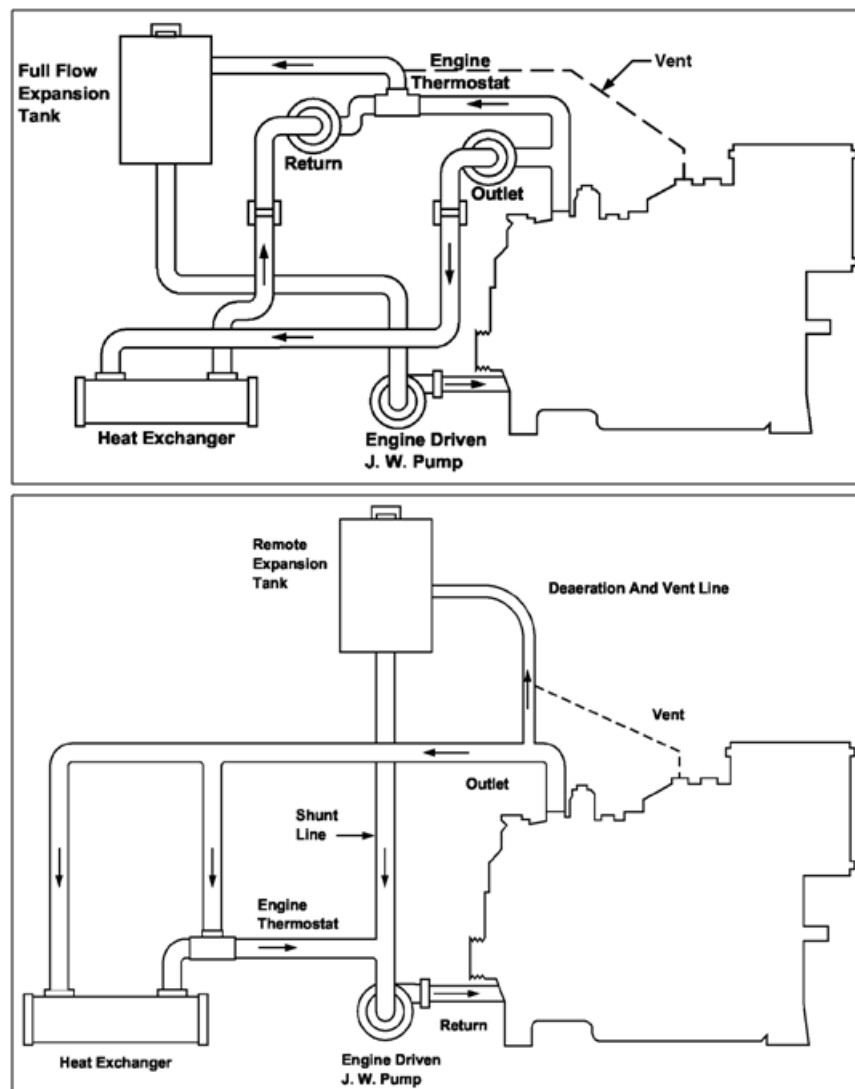

Figure 2.6 — Example of cooling systems showing placement of full flow versus remote expansion tanks.

Caterpillar also offers expansion tanks as factory options for some engine models, sized for the fluid volume listed for the engine; they will not be adequate for systems that are significantly larger than that volume. Unless otherwise specified, assume factory engine mounted expansion tanks are constructed to support pressures up to 96 kPag (14 psig). This limit may not be sufficient for high temperature cooling system designs, in which case a custom expansion tank should be provided. Factory expansion tank offerings are typically limited to the jacket water circuit only. The installation must still incorporate an expansion tank for the auxiliary cooling circuit as well.

2.3.2 Bladder-type Expansion Tanks

A bladder-type tank is most commonly constructed as a cylindrical pressure-rated vessel that includes a replaceable rubber bladder (or diaphragm) inside. This construction creates separated chambers inside the tank, but the dividing wall between them is flexible. This flexible barrier separates the coolant on one side from a pressurized air chamber on the other. Because coolant is an incompressible fluid, the pressurized air will compress and expand to accommodate the changes in coolant volume due to temperature or leakage. This accomplishes two things at once:

- The pressurized air fill allows the tank to handle coolant expansion when it occurs.
- The pressurized air exerts a near-constant pressure on the coolant volume.

By providing added static pressure to the circuit without relying on gravity acting on a liquid column, a bladder-style tank can be mounted level with the rest of the coolant system. This can be very useful for installations where vertical space is limited. However, it should be noted this configuration does not provide for deaeration. Manufacturer's installation guides may show a mechanical vent valve that allows air (but not coolant) to escape at that point. Installation, set-up, and operation of this type of tank should be according to the tank manufacturer's instructions.

2.3.3 Sizing Expansion Tanks

The required expansion volume for the jacket water circuit can be calculated based on the coolant temperature change and type of coolant. Approximate values for the expansion of different coolant mixtures are shown in Figure 2.7. The minimum required expansion volume for the jacket water on standard cooling systems is 15%. High temperature systems designed for operation above 100°C (212°F) will need a larger volume to handle the after boil that may occur on the hot shutdown (see the section on High Temperature Solid Water Systems in the Heat Recovery section for more information).

The required minimum expansion volume for the auxiliary (aftercooler) circuit is 8%. The smaller fluid volume of this circuit, combined with the lower operating temperatures involved, drive less thermal expansion of the coolant fill and do not require as much expansion volume.

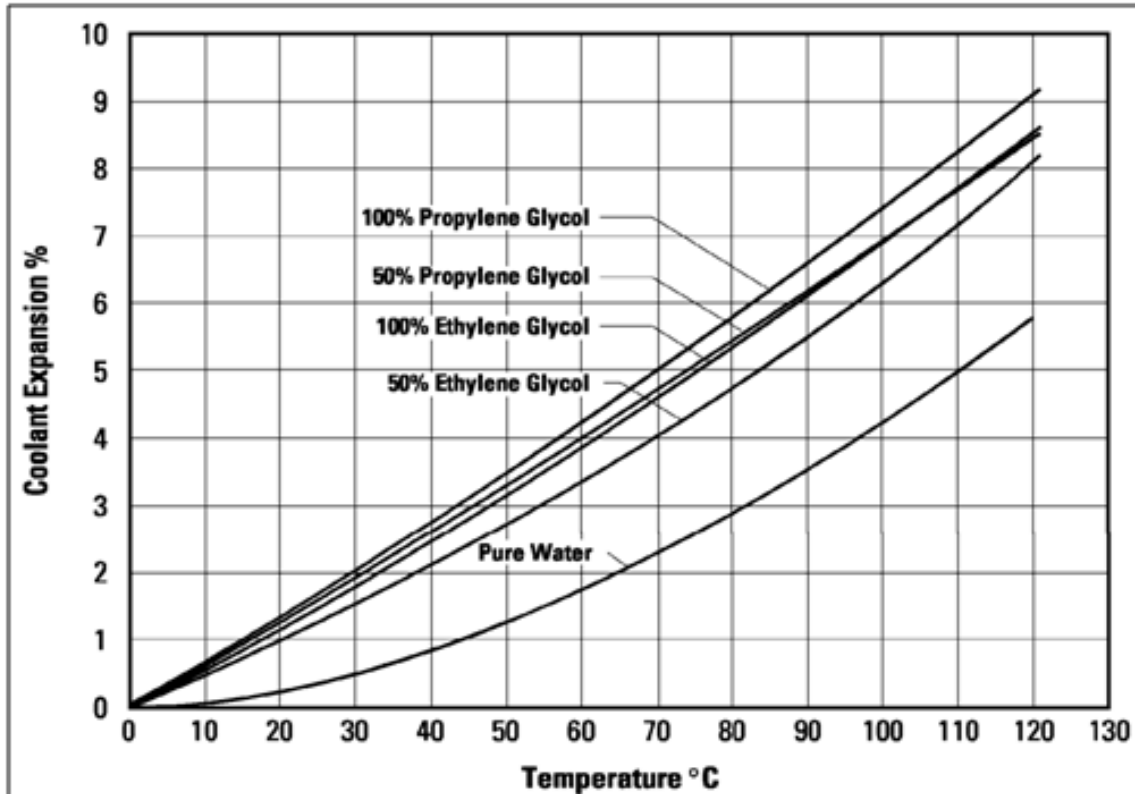

Figure 2.7 — Approximate coolant expansion rates for various coolant blends.

2.3.4 Coolant Piping and Connections

The engine's cooling systems and the external components that complete those flow circuits must be connected to function as a system. Whether it is on an all-inclusive packaged unit or part of a larger installation, some additional piping is required to complete the cooling circuits. While not complex, the selection of appropriate piping for completing the system is essential to ensuring proper cooling performance.

Piping is typically iron or steel construction, following industry best practices for the connections used between pipe segments. Pipe routings are kept compact to limit the overall system fluid volume. This is especially helpful for engines that use off-engine mounted thermostats, since the coolant volume captured in the bypass loop affects the time required to bring the engine up to full operating temperature.

Coolant piping must be adequately supported. The weight of the coolant in the pipes adds considerably to the load placed on the supports, so be certain they are sufficient to support the combined weight load. Supports for pipes leading off the engine should be mounted to the surroundings (and not the engine) where possible, especially for larger engines where pipe sizes are larger and the suspended mass is considerably greater. Piping supports tied to the building structure (for enclosed installations) are acceptable, as are free-standing support structures. Connections between the engine and the surroundings should use compliant couplings to accommodate the vibration energy of the engine and to accommodate dimensional changes in the joint due to thermal growth. Supports must also be located to take the weight of the pipe (and coolant) off the points of connection. Excessive overhung weight on the pump inlet, mixer box outlet, temperature regulators, or expansion tanks can lead to damage in those components.

Cooling System Components and Construction

Finally, the connections between the engine and its surroundings form a critical junction between a high vibration zone (the engine) and a relatively low vibration zone (the larger installation). The potential for relative movement between these two zones demands that all connections crossing the boundary between the zones be completed using flexible or compliant couplings. The image in Figure 2.8 is meant to emphasize this concept: that all items connected to the engine should be understood to be in the high vibration zone and all items connected outside the box are part of a lower vibration zone. Any hard connections crossing the zone boundary will be subject to cyclic stresses due to the different levels of vibration present in the two zones, and for that reason are subject to fatigue.

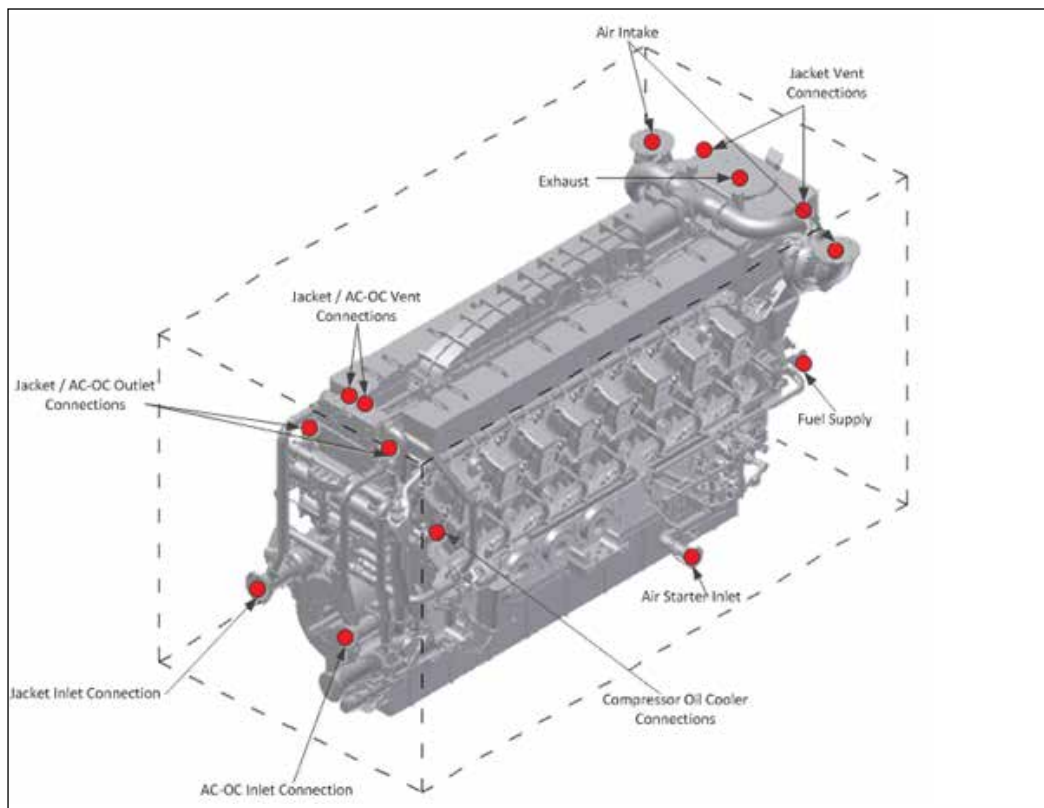

Figure 2.8 — The engine as a vibration source. All connections to the high vibration zone, shown in the boxed region, must be decoupled from externally-supported connections (the low vibration zone) by means of flexible couplings.

2.3.5 Cooling System External Connections

The engine's cooling systems must connect to the external coolant piping, and in doing so it will cross the vibration boundary mentioned in the earlier section on managing vibration between the engine and its surroundings. Flexible joints must be used in these connection locations to provide:

- tolerance for misalignment of the two piping systems
- compliance for relative movement and thermal growth
- isolation to limit transmission of vibration through the connection

Different styles of flexible joints contribute different properties when used, and the characteristics of each must be considered when selecting a particular style for your installation.

Cooling System Components and Construction

The rubber spherical joint provides the greatest flexibility within the connection. It is considered the best choice for achieving isolation across the joint, but it will not provide much support for long cantilevered pipe runs where structural supports cannot be placed near the joint. This style of joint is recommended because it excels at all three of the properties above.

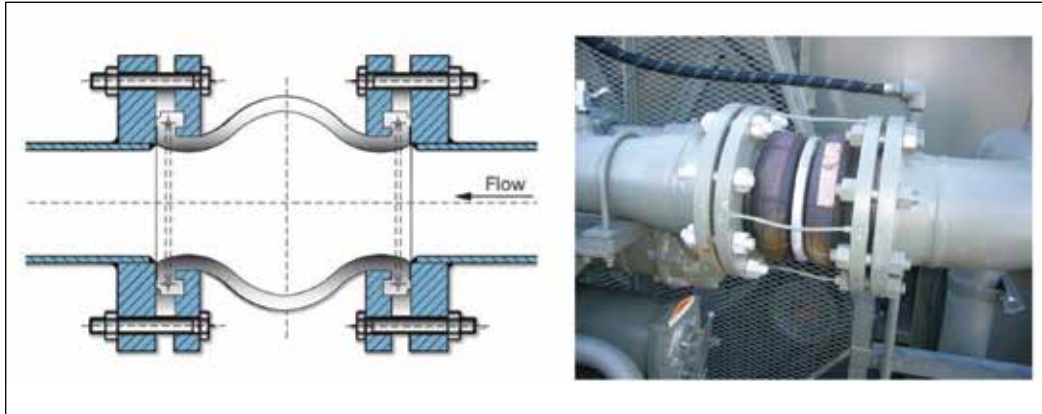

Figure 2.9 — Rubber spherical joint.

The Flexmaster coupling is very commonly seen in engine cooling system applications. It provides some degree of compliance for all three of the properties above, but is not as compliant as the rubber spherical design. The nature of the slip joints on each end limits the amount of misalignment it can support, and it does transmit more vibration through the joint due to the rigid sleeve joining the two sides. This increased rigidity does mean this style of joint can provide more support to the free end of a pipe run than is contributed by the rubber spherical design. While not recommended as a primary support for the pipe, this increased rigidity across the joint can help to limit the resonant response of the pipe to vibration inputs from its surroundings. This design works well for pipe diameters of 3 inches (76 mm) or less and is best used in connections that do not cross the vibration boundary. For larger diameter pipes and for connections from the engine to its surroundings the rubber spherical design is preferred.

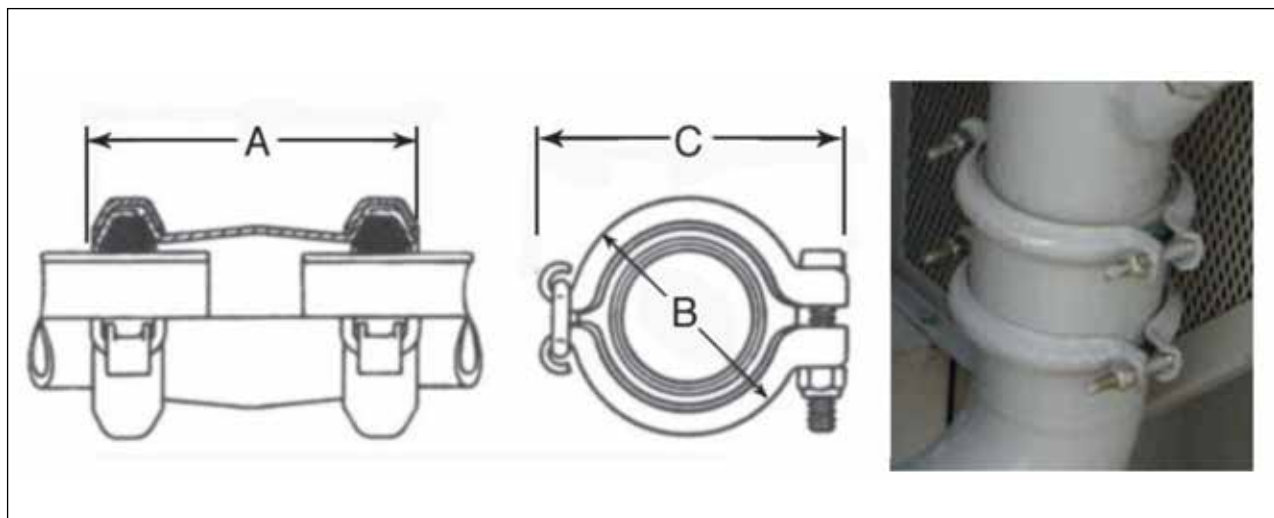

Figure 2.10 — Dresser coupling.

Cooling System Components and Construction

Another coupling commonly seen in use is the Dresser style. It is a simple design in which the two pipe ends are joined by a rigid sleeve sealed at the ends by wedge-shaped rubber rings clamped in place by bolted flanges. While this design is economical it provides little isolation for vibration through the joint and seals well only across a limited range of pipe misalignment offset distances. It is not recommended for large engine installations.

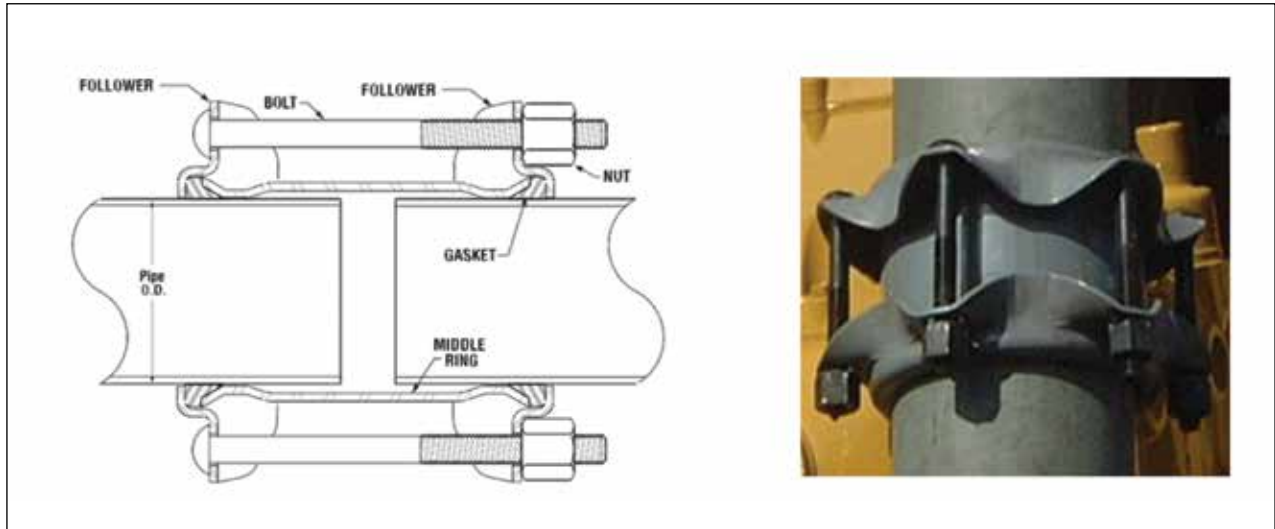

Figure 2.11 — Flexmaster coupling.

2.3.6 Deaeration

In spite of being a closed system, air can become trapped in the cooling system. This happens at the initial fill and during normal operation, through the movement of the coolant around the complex internal passages of the system components and through the escape of combustion gases into the coolant flow. The air and gas caught in the system must be separated and vented to prevent deterioration of the system's performance or an increase in the possibility of pump cavitation.

The key to deaeration is separation – the captured air or gas must be allowed to escape from the liquid coolant to remove it from the system. The process by which this is done can be quite simple when planned into the flow path, although situations arise where specialized devices must be used to accomplish the task. In its simplest form, separation of gas and liquid is done by deceleration of the coolant flow. The air or gas bubbles become entrained in the coolant flow because the inertial forces of the moving coolant are greater than the other forces acting on them. By slowing the linear movement of the coolant, the buoyant forces acting on the air or gas bubbles can overcome the forces of the moving liquid, allowing the bubbles to rise upward. Deceleration zones must be designed into the coolant path to make this happen.

Deceleration zones are nothing more complex than a widening of the flow passage. While the coolant's volumetric flow rate is constant through the circuit, its linear velocity changes depending upon the cross-sectional area of the passage. So, to slow the linear velocity, increase the cross-sectional area. Figure 2.12 shows a simplified view of this. The two examples at the top show venting connections tied to flow lines with no deceleration zone. For those cases there is little opportunity for the bubbles to escape the main flow and so they are not available to move up the vent path. In the example at the bottom of the figure, the flow path is widened for a short distance, and over that distance the coolant's linear velocity drops in proportion to the increase in the cross-sectional area of the widened passage. In this space the bubbles can rise to the top to find their way to the vent tube and out of the coolant.

Cooling System Components and Construction

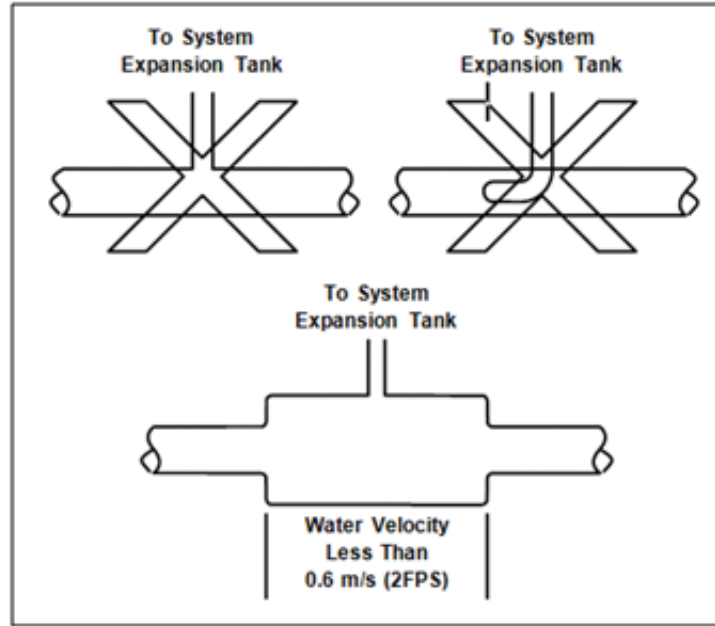

Figure 2.12 — Examples of proper and improper tie-ins of venting tubes to the main coolant flow path. The upper two examples do not provide a deceleration zone to allow entrained air/gas bubbles to separate from the coolant flow. The lower example widens the passage to slow the flow of coolant, allowing the bubbles to rise upward and escape through the vent tube.

For the best opportunity for separation of bubbles from the liquid coolant, the deceleration zone must reduce to the coolant's linear velocity to under 0.6 m/sec (2 ft/sec). This can be accomplished using baffles or a temporary widening of passage. This is most effective when the deceleration zone is located near a high point in the overall flow path. Because of the buoyant force acting on it, any separated air or gas will accumulate in that high point, making it an ideal location for a venting connection (see Figure 2.13). Where this can't easily be done it may be necessary to use a mechanical deaerator, such as a centrifugal air separator. Such devices rely on the difference in density between liquid and gas to achieve a high rate of separation between the two. Once the liquid and gas are separated, the gas must be transported to a location where it will not simply become reentrained in the liquid flow once more. That is the role of the venting system.

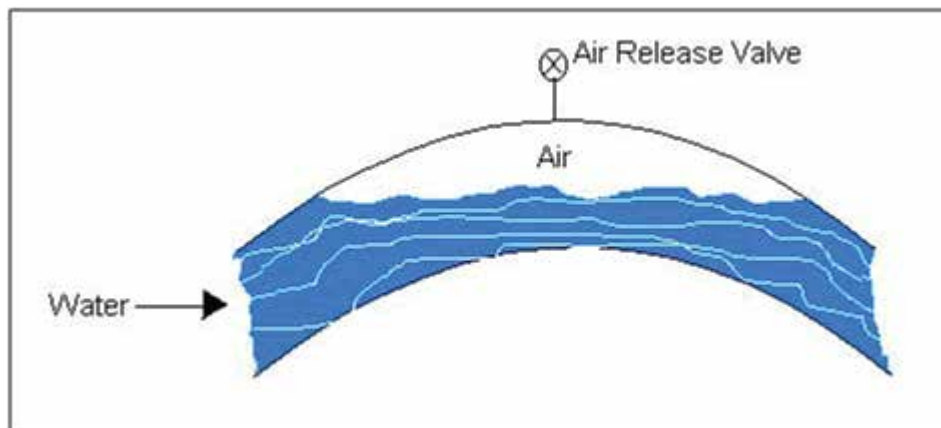

Figure 2.13 — A high point in a coolant passage showing accumulation of trapped air. This is an ideal location for a release valve or vent line connection.

2.3.7 Venting

The venting system is perhaps one of the more under appreciated components of the cooling system. As explained above, its job is to make certain the cooling system's performance isn't compromised by entrained air or gas bubbles. Air or gas bubbles entrained in the coolant flow can affect the cooling capability of the coolant. Where possible, those bubbles will exit the coolant flow and collect in high points of the flow path under inversions of the path that form *traps* (see Figure 2.13). Such traps are actually useful as long as they are vented. However, too many inversions in the flow path would lead to a highly complex venting system if all traps are vented. It is important to design in locations to serve as dedicated venting points, then construct the remainder of the flow path with no inversions to form unintentional, unvented traps.

Figure 2.14 shows an example of a venting connection on a G3500 Engine. In this example; coolant is routed to the bearing cartridges of the engine's turbochargers. The tubes carrying the coolant form traps, so vent connections were added to the design to ensure the air traps do not become air *locks*, where the trapped gas interrupts the flow of the liquid coolant. This design includes tubing from the two turbo vent locations to carry the separated bubbles upward to a single connection point on the top deck of the aftercooler. This single connection point is located on the engine's general dimension drawing as a customer connection location that must be tied to the vent system.

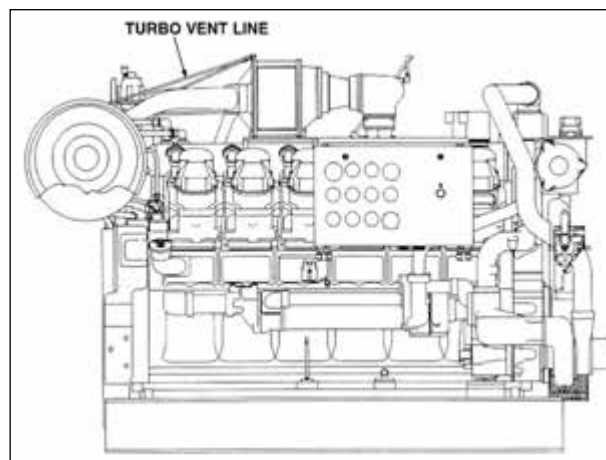

Figure 2.14 — Venting connections on the engine.

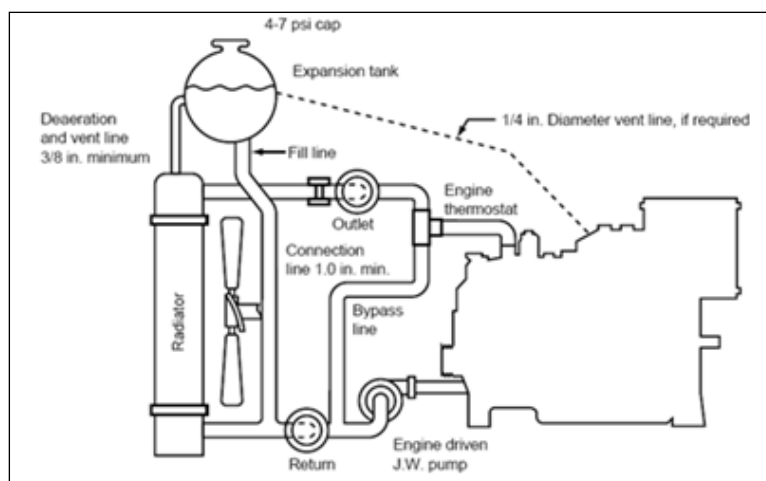

Figure 2.15 — Diagram showing the continuous upward slope of a basic vent line connecting the engine's vent location to the expansion tank.

Cooling System Components and Construction

The vent system is the group of all of the external routings necessary to transport air/gas bubbles away from all vent points and out of the main coolant flow path. Because the cooling system is a pressurized, closed system, the outlet of the vents must also be within the closed system. For this reason, the expansion tank in each flow circuit is commonly used as the terminus for all vent lines serving that circuit. Buoyancy is the natural force driving the bubbles through the vent lines, so each vent path must travel a continuous upward slope. Any breaks in this upward slope serve as traps that inhibit the operation of that vent path.

Small diameter hard tubing is common in vent line service; however, pipe and flexible hose are also commonly seen. Because the vent system gathers from vent locations across the engine, the span of the network of vent paths can be quite large across the engine installation. A large span of small diameter tubing becomes a risk for fatigue-related leaks when subjected to vibration, which is commonly present on an engine installation. Protecting against vibration-related issues adds support and isolation to the list of concerns to take into account when designing a venting system.

Figure 2.15 greatly simplifies the challenge of routing vent lines; in an actual installation the tube routings, support structures, and flexible connections used in the vent system can be quite complex. Given the expansion tank must be the high point in the system and that servicing technicians may routinely access the space through which the vent lines must pass, it is well worth the time and effort to devise a venting strategy that puts all of these critical considerations together in harmony.



Figure 2.16 — Vent line installations showing both hard tubing and flexible hose in use.

The venting solutions shown in the images above are common for large engine installations. In both examples, the vent lines from the rear of the engine are brought forward close to the top of the engine. For such a routing, two details are almost certain: the vent lines are supported off the top of the engine and they are exposed to any service work being done in the space above the engine. Both instances show a protective channel installed around the horizontal run of tubing, the simplest protection available for this routing. Both instances do not, however, isolate the tubing run from the engine's vibration, leaving open the possibility of chafing at the support points or fatigue at tees and other points of connection. The image at the right shows the vertical rise being completed using flexible hose. This is an effective way to decouple the vent lines from the engine's vibration, but care must be taken to ensure the hose does not sag to form an inversion, and that the hose material is suited to its environment (e.g., stainless steel braided hose may be appropriate if the vent routing passes near the exhaust system). Just as with the main cooling system connections, connections in the venting system should consider the "zone boundary" image shown previously when determining where flexible connections are needed.

The diameter of the vent lines is also a consideration. Vent lines that are too small inhibit the free movement of the bubbles through the near-stationary liquids in the lines. Vent lines that are too large may promote circulation of the liquids, sometimes to the detriment of the performance of the cooling system. Vent lines must have an inner diameter of at least 9.5 mm (0.375 in) and not larger than 12.7 mm (0.5 in) for best performance. Upon arrival at the expansion tank, the vent lines should connect at the tank bottom. As the coolant expands or contracts, it migrates through both the main shunt tube and through this vent connection. Connecting further up on the expansion tank, or even above the fluid level, can inhibit the movement of liquids and can ultimately compromise the venting performance of the lines.

Inevitably, circumstances will arise that will not permit one or more vent locations to be directly tied to the expansion tank. In such a case it may be necessary to use a mechanical vent valve to allow air to escape a trap. Mechanical vent valves are often float valve designs that allow air or gas to exit a port that is then closed when liquids reach the opening. All such vent valves require regular inspection and periodic servicing to ensure their continued function. Refer to the valve manufacturer's instructions for further installation and operation guidance.

2.4 System Filling, Draining, and Servicing Considerations

Filling the system involves both the introduction of the coolant and removal of the air it displaces from the system passages. While the obvious location for filling the system is at the pressure cap on the expansion tank, it is also possible to pump coolant into the system through the bottom drain ports.

Due to the limited area of the fill/vent neck at the top of the expansion tanks, the fill rate there should be limited to a maximum of about 19 L/min (5 gal/min). When pumping coolant through a connection near the bottom (the lowest point) in each circuit, the rate should be limited to about 113 L/min (30 gal/min). While it is clear the pressure cap will be removed when filling from the top, please remember to remove the cap when filling from the bottom. This will help the displaced air exit the system. When filling from the bottom it is also recommended to loosen the vent connections during filling to help trapped air escape. Remember to replace the vent connections once the filling process is complete.

There will be times when it is necessary to service engine attachments that tie into the cooling system. Draining and refilling the system can be very time-consuming and are particularly unwelcome when the work to be done does not line up with the regular cooling system service schedule. Installing isolation valves around those devices can enable performing the service without a full drain-down. Of course, provisions should also be in place to ensure the isolation valves are returned to the open position once the service work is complete. Lockouts can help to avoid unintended actuation of isolation valves during engine operation.

In general, design for serviceability is an important rule when completing the installation layout. There should be adequate room around all serviced components (pumps, heat exchangers, thermostats, radiators, heat recovery units, deaerators, etc.) for removal of the serviced parts. This includes provisions for the installation of temporary strainers in each circuit, upstream of the pump inlet.

2.5 System Management

2.5.1 Temperature Control

For liquid-cooled engines there are basically two strategies for regulating the temperature of the system: inlet or outlet control. The two differ only in the placement of the thermostatic control valve (thermostat), yet each carries advantages and disadvantages that should be considered when selecting the best one for your installation. In each case the thermostat is connected to both the main flow path and a "bypass" or "recirculation" path. Based on the temperature sensed in the coolant coming to the valve, the flow is directed through one path or the other, or a portion to each. The regulated temperature is achieved by the blending of the flow that is sent to the external cooler (cool) and the flow that bypasses the cooler (hot).

Cooling System Components and Construction

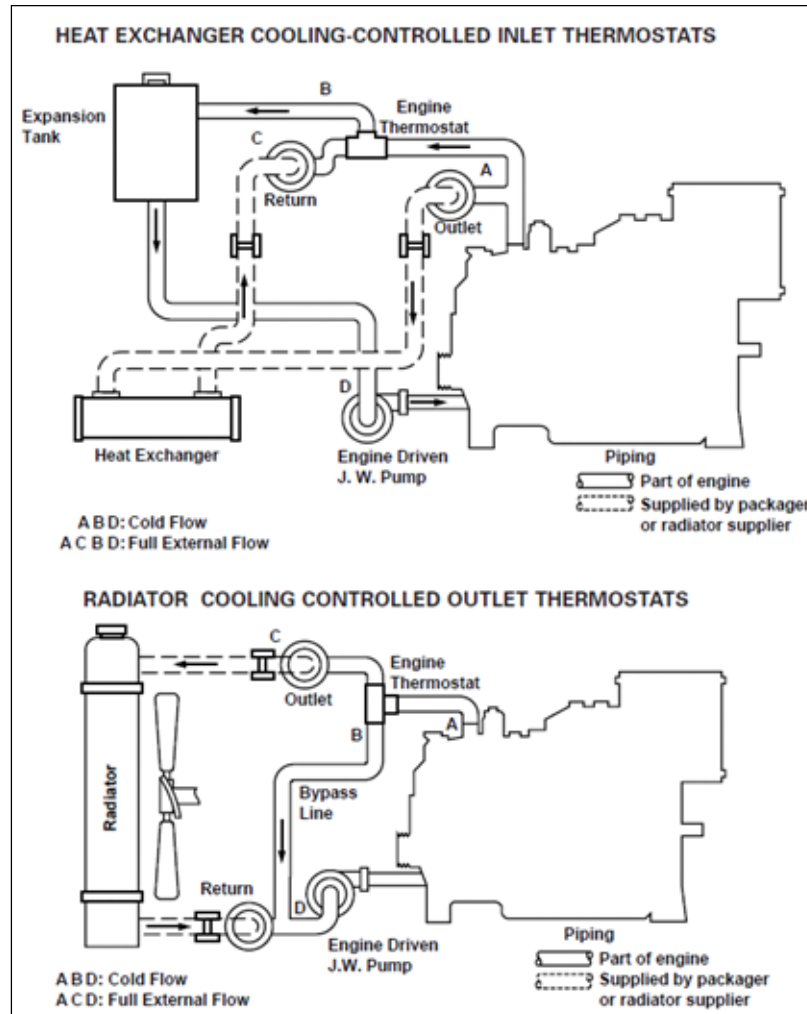

Figure 2.17 — External flow layouts for an inlet-controlled system for a heat exchanger cooled engine and for an outlet-controlled system as applied to a conventional radiator cooled engine. Note the use of a separate full flow expansion tank on the heat exchanger system, as compared to the expansion volume being included in the top tank of the radiator in the radiator cooled example.

Inlet-controlled systems position the thermostat between the external cooler and the suction side of the circulating pump. This thermostat's temperature set point is close to the target temperature intended for the engine's cooling system inlet. Clearly this placement provides the most positive control of the temperature delivered to the system, since the regulating valve is directly in front of the inlet to the on-engine cooling circuit. There are disadvantages to an inlet-controlled system. By placing the thermostat (a restriction to flow) ahead of the pump inlet, the pump's suction can pull down pressures locally between the thermostat and the pump. Low suction pressures in a vane-type coolant pump can lead to cavitation, a process that can cause great damage to the pump. Also, the lack of a restriction between the engine outlet and the external cooler means the cooler is subject to full engine outlet pressure at all times. These outlet pressures can be close to the structural limits of a soldered-tube radiator, posing the risk of damage to the radiator. Care must be taken to design for an adequate flow rate in this system, as low flow rates can produce high temperature rise across the engine and may result in nuisance high outlet temperature shutdowns. Concerns over pump cavitation can be addressed in the piping design; using a full-flow expansion tank, or including a shunt line from a remote tank, should add sufficient pressure at the inlet to protect the pump.

Outlet-controlled systems place the thermostat between the engine outlet and the external cooler. They still regulate temperature by diverting some flow through the bypass, but an outlet-sensing thermostat's temperature set point is set for the higher temperature expected at the engine outlet. By not placing a restriction directly ahead of the pump, outlet-controlled systems greatly lower the likelihood of pump cavitation. In a similar manner the outlet thermostat provides a restriction that lowers the pressure sent to the cooler, helping isolate a radiator from the full discharge pressure of an inlet-controlled system. The outlet-controlled design can interrupt the path for filling of the system; a fill line from the expansion tank to the engine can solve this problem. Outlet control does introduce a lag between the sensing of the temperature at the thermostat (at the engine outlet) and the actual mixing of the hot and cold flows (at the engine inlet). With this lag it becomes much more possible for the system to send a large quantity of cold coolant to the engine, creating a risk of thermal shock. Overcooled cylinder liners surrounding very hot pistons can lead to piston/liner damage, or potentially more severe consequences.

2.5.2 Pressure Control

Liquid-cooled systems must maintain the coolant in the liquid state to be effective, for if the coolant changes to vapor its heat carrying capacity drops tremendously and localized overheating can result. The transition from liquid to vapor (boiling) is a function of both temperature and pressure, with boiling occurring more readily at higher temperatures or lower pressures. To improve control of boiling under high operating temperature conditions, the liquid cooling system is operated at a small positive gauge pressure, which raises the boiling point temperature of the coolant. This effect of system pressure on the boiling point becomes more important as the site altitude increases. The diminished barometric pressure at altitude lowers the boiling point of liquids, including the coolant, and the boosted system pressure is the simplest fix for this.

Pressure regulation for a liquid-cooled system is accomplished using an automotive-style radiator cap on the expansion tank. This type of pressure cap is designed specifically for the task of managing pressure in an engine cooling system that may cycle between the maximum operating temperature and very low temperatures when the engine has been shut down. Do not use other types of pressure relief valves for this function.

Another variable that can impact the boiling point for a given cooling system is the choice of coolant. Water is an excellent choice for heat carrying capacity, but it carries weaknesses in its tendency to oxidize ferrous metals and in its relatively low boiling point when compared to other coolants. These limitations can be modified by mixing water with other coolant compounds. Ethylene glycol is a proven coolant additive that is effective at limiting oxidation and raising the boiling point. It does reduce the heat carrying capacity of the coolant mixture, but this is addressed in the heat flow calculation by using the appropriate values for the specific gravity and specific heat properties of the coolant.

More information about coolant selection can be found in the section titled "Coolant."

Figure 2.18 shows the impact of both altitude and coolant makeup on the boiling point; altitude effects can be seen in the upper chart, while the comparative effect of mixing ethylene glycol and water can be seen by comparing the two charts to one another. As noted in the caption, the single trace on the glycol chart is for zero gauge pressure; this trace can be compared directly to the left-most trace on the water chart.

In very rough terms, each 7 kPa (1 psi) increase in the system gauge pressure raises the boiling point of water about 2°C (3.6°F). As seen in Figure 2.18, this is an approximate rule of thumb. For a typical standard temperature system, with operating temperatures up to 99°C (210°F), the system pressure should be set to 28-48 kPag (4-7 psig) to provide adequate margin against boiling. Higher temperature systems, such as 110°C (230°F) landfill cooling or 127°C (260°F) combined heat and power systems, require higher system pressures to manage the boiling point. To illustrate how this can be calculated, consider the case of changing from a 99°C (210°F) standard cooling system to a 110°C (230°F) Low Energy Fuel cooling system application:

Cooling System Components and Construction

- Per the steam tables, saturation pressure @ 99°C = 97.8 kPaa (@ 210°F = 14.1 psia)
- At sea level atmospheric pressure of 101.4 kPaa (14.7 psia), saturation temperature increases to 100°C (212°F), a very small margin against boiling.
- With a +48 kPag (+7 psig) increase in system pressure (now 149.4 kPaa or 21.7 psia), saturation temperature increases to 110.4°C (230.7°F). Thus the standard pressure cap provides 11°C (20°F) margin against boiling.
- Per the steam tables, saturation pressure @ 110°C = 143.4 kPaa (@ 230°F = 20.8 psia)
- To reach a similar margin against boiling of 11°C (20°F) requires system pressures of 205.1 kPaa (29.8 psia), which is an increase of 103.7 kPa (15.1 psi) over atmospheric.

This shows that for the higher temperature cooling system, the higher rated pressure cap is needed to maintain a margin against boiling similar to that of the standard pressure cap for the standard temperature cooling system. Note that these changes in system pressure should be compared to the operating limits for the components selected for the system. The design of the radiator/cooler must be capable of supporting the system pressure selected for operation.

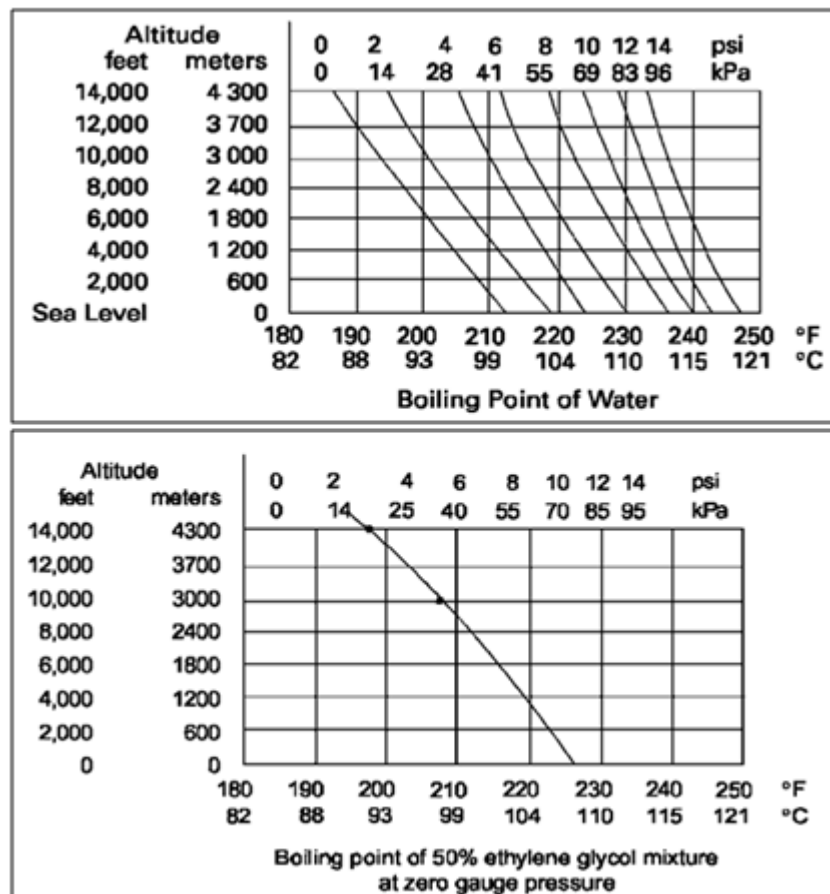

Figure 2.18 — Charts showing the effect of altitude on system pressure and, consequently, on boiling point. The upper chart displays values for water; the lower chart for a blend of 50% water and 50% ethylene glycol. Note that the water chart shows gauge pressure values from 0 to 96 kPa (14 psi), while the glycol chart shows only zero gauge pressure. Using 1200 meters as an example, straight water would boil at 96°C (205°F) but a blend with 50% glycol would not boil until almost 104°C (220°F). Increasing the system pressure using a pressure cap has the effect shown in the water chart to raise the boiling point.

2.5.3 System Temperature and Pressure Limits

System limits exist to protect the engine from potentially-damaging extremes in either temperature or pressure. The actual limiting values may vary for different engine models, depending upon the specifics of the design and of the cooled components used on each.

Consult the Technical Information sections of the A&I Guide for model-specific information on temperature and pressure limits. The Technical Information section titles and publication numbers may be found in the "References" listing at the end of this Guide.

2.6 Cold Weather Considerations

In addition to the discussions below, information on operation, lubrication, and maintenance in cold weather conditions may be found in service publication SEBU5338, Cold Weather Operation.

Commercially available radiator shutters should be considered. Fan air flow across the engine increases heat lost to radiation. Particularly at light load, shutters minimize this heat loss and raise the engine temperature.

Commercially available diesel fuel fired jacket water heaters should be considered on engines that must start when no AC power is available.

Engine enclosures or engine room enclosures are recommended to retain engine heat.

2.7 Extreme Cold Weather Considerations

Extreme conditions require additional protection, examples of which appear in Figure 2.19. System layout details, such as the use of shutters on the radiator or placing the radiator in a separate room from the engine can help, since eliminating the air flow over the engine from the radiator fan will keep the engine and its servicing surroundings warmer.

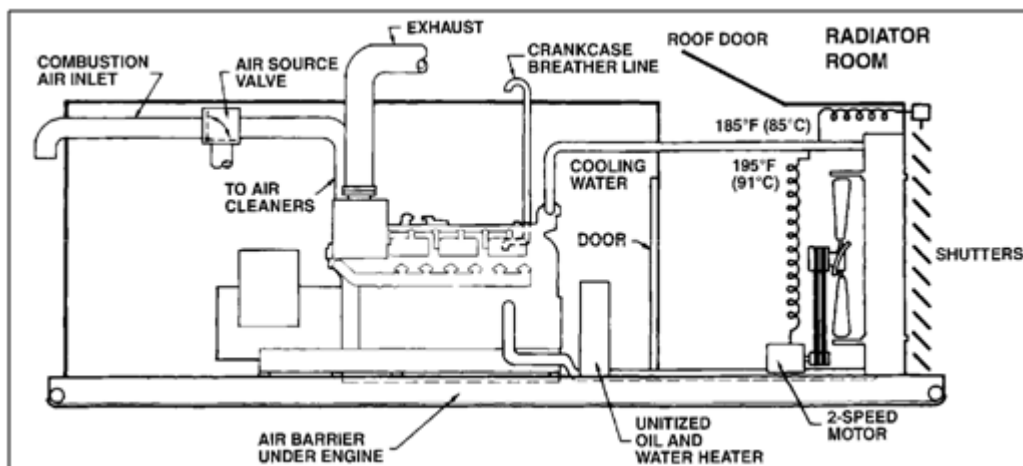

Figure 2.19 — Diagram showing features helpful in an extreme cold environment.

The use of a remote radiator/cooler typically means an electric motor driven fan is used, and this opens an opportunity for optimizing fan operation for the environment. The increased cooling potential of the frigid air (think coolant to air approach temperature) means much less air flow should be needed through the radiator. Adding speed adjustment to the fan operation can optimize warm up times and reduce the power draw of the fan while the cold conditions are present.

Limiting the engine's exposure to excessive heat loss and maintaining a tolerable environment for operation and servicing go hand in hand. Air flow through the engine enclosure should be carefully planned, and all sources of leakage should be considered. This includes an air barrier under the engine oil pan, as illustrated. Because the engine's combustion air flow rate can be considerable, allowing the engine to pull its air from inside the enclosure will force air exchange rates around the engine that will drive down temperatures. Combustion air can be ducted to the air cleaner from outside, as shown, with an air source valve included so the engine can be started and idled on the warmer air in the engine room when combustion stability is very sensitive to temperature. The air intakes should also get regular attention to prevent surface icing from blocking intake air flow. Heavy-duty air cleaners can be utilized for protecting the engine from air cleaner plugging due to "ice fogs," if they occur.

Engine fluids, such as coolant and lubricating oil, are sensitive to extremely low temperatures. Even treated coolant will freeze under extreme conditions, and lube oil viscosity increases tremendously at very low temperatures. Fluid heaters are necessary under such conditions, but extreme cold can make passive (convection-circulated) heaters ineffective. For frigid conditions, a forced-circulation heater system should be used. Heater connections to the engine must be executed properly for the system to be effective; guidance on completing proper heater connections may be found in the section that follows, and in the other publications noted.

2.8 Jacket Water Heaters

Jacket water heaters are recommended for sites that encounter ambient air temperatures below 21°C (70°F). Heating the engine fluids prior to starting will, at the very least, improve startability and reduce the time required to achieve a successful start. For larger engine models minimum fluid temperature requirements make heaters practically mandatory. In high-humidity climates heaters can eliminate condensation (from air trapped in the cylinders) that can interfere with the proper operation of the spark plugs – this is true even above the recommended ambient temperature noted above. Heaters may be offered as optional equipment in some Caterpillar engine price lists.

Engine fluid heater designs can be classified by the nature of their installation (internal or immersion type versus external or tank type) and by how the fluid is circulated (passive or convection-circulated versus pump-equipped or forced-circulating). Heater sizing is based on the volume of coolant that must be maintained; hence, engine displacement is often used as a sizing criterion. Ambient conditions also play a role, so sizing to support a given fluid temperature may result in one heater for a specified ambient temperature under calm conditions. When a 24 km/h (15 mph) wind is present, the heater sizing requirement may double.

Correct installation (connection into the engine's cooling system) is important to the effectiveness of all jacket water heaters. Incorrect connections can bypass large portions of the cooling circuit, limiting the impact of the heater on the engine. Convection-circulated heaters are especially sensitive to proper connection location and execution, since the movement of the coolant is only driven by the temperature profile vertically across the flow path – hot fluid rises while cooler fluid falls. The optimal choices for tying the heater to the engine will promote fluid movement based on that temperature profile. Inversions in the flow path, even if slight, will cause circulation to fail and render the heater ineffective. Upward flow from the heater to the engine and downward flow from the engine to the heater work well for heater installations. Visual representations of these concepts appear in Figure 2.20.

Cooling System Components and Construction

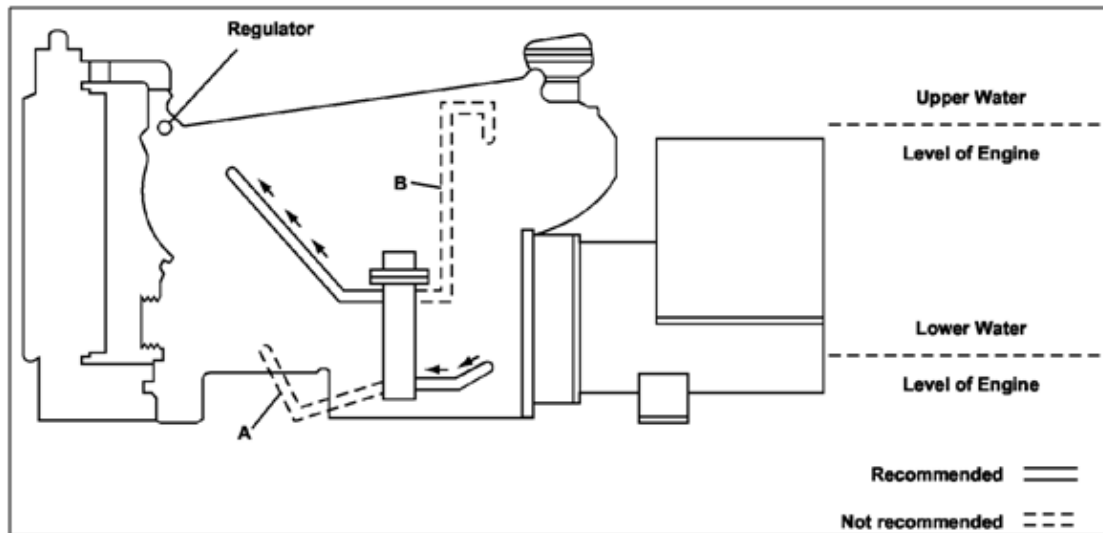

Figure 2.20 — Diagram illustrating best practices when installing a jacket water heater.

Some heater systems incorporate coolant pumps. To prevent coolant bypassing the cylinder heads during engine operation, a check valve must be included in the block heater circuit. Many external heaters have built-in check valves, but test the heater first before installing it to be sure. Pour water in the outlet of the heater; the check valve should prevent the water from flowing through the heater. If the block heater chosen does not contain an integral check valve, one must be installed. The check valve should be installed on the inlet side of the tank.

For customer-installed convection heater type systems, the following general guidelines should be considered.

- Mount the heater as low as possible
- Route the heated coolant near the top of the engine cooling system, but below the temperature regulators
- Pull cold coolant back to the heater from the lowest possible point in the engine cooling system
- Avoid cold water loops; this is any situation where the cold water must rise to enter the heater
- Complete the connections to the engine using pipe the same size as the heater connections, or larger if practical.

Achieving the desired heater performance on a vee engine may require two heaters, one to promote heat circulation on each side of the block.

The normal time required for temperature to stabilize is ten hours for large engines. Wattage requirements for shorter periods are inversely proportional to the ten-hour requirement. Physical location and exposure to the elements can affect sizing. Note that passive immersion heaters must be limited in their heating rate to avoid localized overheating of the coolant. Excessive rates of heat transfer can result in high temperature in the fluid immediately surrounding the heating element, which can damage the working properties of the coolant. Forced-circulation heaters do not allow fluids to remain in the heater for long periods and thus can use greatly increased heat transfer rates.

Field experience and experimentation have identified favorable locations for jacket water heater connections on specific engine models; information on best practices may be available in other publications, such as model-specific engine information guides. The OEM Guides for G3500 and G3600 engines, for example, include just this kind of information and should be consulted for heater installations on those engine models.

2.9 Serviceability and Isolation Valves

Periodic servicing of the cooling system is a defined part of the maintenance schedule. However, some devices in the system require special consideration to ensure the system allows access without requiring draining of the complete system.

Access to heat exchangers is required for cleaning or removal of the tube-bundle assemblies or plates. Engine water pumps must be easy to remove. Remote water temperature regulators should be accessible and have appropriate isolation valves to allow servicing of engine and temperature regulators without draining the entire system. Apply similar guidelines to radiators, heat recovery units, deaeration units, jacket water heaters, and other components possibly requiring service or replacement. Any piping that must be removed during servicing should be designed for ease of handling, with personnel safety always in mind.

2.10 System Monitoring

Provide locations to measure pressure and temperature differentials across major system components. This allows accurate set-up and performance documentation of the cooling system during the commissioning procedure. Future system problems or component deterioration (such as fouling) are easier to identify if basic data is available. It also provides information for relating field conditions to original factory tests.

Temperature and pressure measurement locations should give accurate reading of fluid stream conditions. Preferred locations are in straight lengths of piping reasonably close to each system component. Avoid pressure measurements in bends, piping transition pieces, or turbulent regions. Plan to install monitoring ports during the design and construction of the cooling system. If the ports are installed later, ensure the pipes are cleaned of drill chips and weld slag after the pressure ports are installed. Install sample ports and fittings before the cooling system is filled. The preferred sizes for the ports on the customer side are 1/8 in or 1/4 in NPT and 9/16 in O-ring ports. These port adapters are available as standard Cat parts; refer to the Cat Tool Guide for part numbers. The recommended locations for typical measurement ports are shown in Figure 2.21.

Self-sealing probe adapters are available in several sizes of male pipe threads and straight threads for o-ring ports. The adapters use a rubber seal allowing temperature and pressure to be measured with the engine running without leakage. Probe diameters up to 3.2 mm (0.125 in) may be used. The straight threaded adapters are used on the engines with available ports. Pipe threaded adapters are more easily incorporated in the customer-supplied system. The adapters are an excellent alternative to permanently-installed thermometers, thermocouples, or pressure gauges. They are not subject to breakage, fatigue failures, and gauge-to-gauge reading variations.

Cooling System Components and Construction

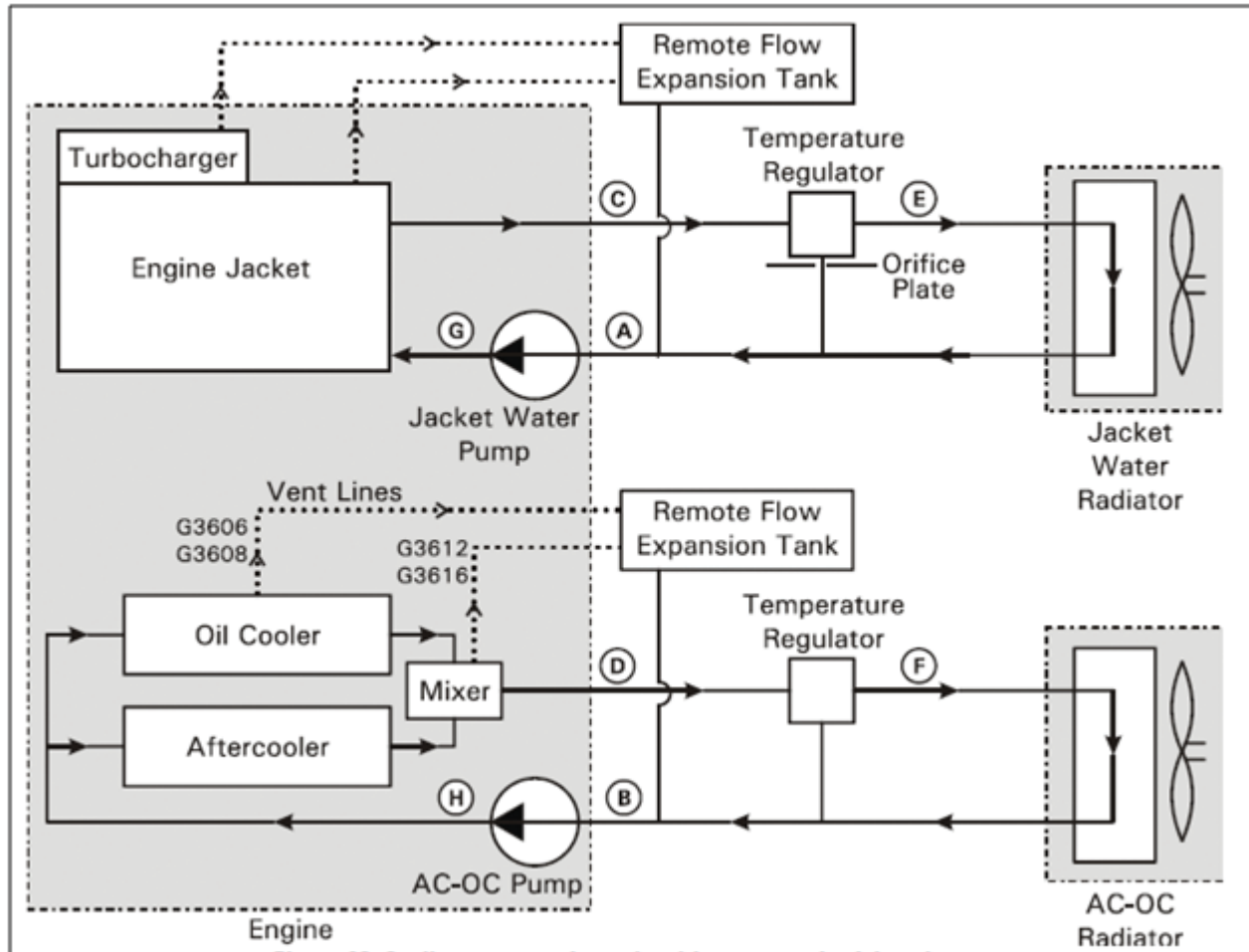

Figure 2.21 — Cooling system pressure check locations, as illustrated for a G3600 Engine.

Refer to Figure 2.21 for cooling system pressure check locations. Static pressure checks should be performed and the results recorded at the following locations:

- A. Water pump inlet
- B. Auxiliary water pump inlet

Dynamic pressure checks are performed with the temperature regulators in the full open position and include items A and B above plus the following:

- C. Jacket water engine outlet
- D. Auxiliary water engine outlet
- E. Jacket water temperature regulator outlet
- F. Auxiliary water temperature regulator outlet
- G. Jacket water pump outlet
- H. Auxiliary water pump outlet.

Pressure checks can be highly simplified by the use of pressure gauges or pressure fittings (see Figure 2.22) at the locations identified above. Caterpillar offers pressure probe groups 5P2720, 5P2725, and 5P3591 and pressure probe 164-2192, which facilitate both static and dynamic pressure checks.



Figure 2.22 — Pressure test fittings and testing probe.

2.11 Cooling System Protective Devices

A common problem associated with properly installed cooling systems is loss of coolant, generally due to breaking a water hose or overheating, which can have many causes. As with many engine safety devices, the decision to automatically shut down the engine, or to continue operation risking total engine destruction, is for the careful consideration of the owner. As an example, under conditions where an entire boat and the lives of those on board are at stake it may be appropriate to use a safety system which does not have automatic shutdown capability. This gives the boat's pilot the option to continue operation of a distressed engine to provide the engine power to escape the immediate danger, even if it results in damage to the engine.

2.12 Coolant Level Switches

Coolant level switches are devices which can give early warning of coolant loss. They generally consist of a sealed single pole-double throw switch, actuated by a float which rides on the surface of the coolant in the expansion tank. It is good design practice to locate the coolant level switch in the highest part of the cooling system; this will provide the earliest warning of a drop in coolant level. High water temperature switches will not give warning of coolant loss; their temperature sensing portion works best when surrounded by liquid water rather than steam.

2.13 High Coolant Temperature Switches

High water temperature switches are devices which continuously monitor the temperature of some fluid, generally coolant, and actuate switch contacts when the fluid temperature goes above some preset limit. In the case of jacket water coolant, the set point is usually between 96° and 102°C (205° and 215°F), depending on the engine, cooling system type, and whether alarm of impending problems or actuation of engine shutdown systems is desired. Switches can be set for either condition.

3.0 Types of External Cooling Systems

In the same manner as on the engine, there are many ways one may design the portion of the cooling system external to the engine. Each variation has advantages for certain applications.

3.1 Radiators

The radiator is perhaps the most commonly seen external cooler used on internal combustion engines. In its simplest form, the radiator used for cooling large heavy-duty engines is recognizable as the same as the radiator in the cooling system in an automobile, but specialized needs drive very different configurations of what is essentially the same device – a liquid-to-air heat exchanger.



**Figure 3.1 — A radiator cooling a G3304 NA Gas Compression Engine (at left).
Note the second fan and cooler for the compressor gas near the rear of the package.**

As seen in Figure 3.1, many small engines mimic the automotive installation model, using a radiator that is vertically mounted close to the engine to allow for a direct mechanical drive of the cooling fan. This type of radiator installation makes sense because it is simple, compact, and it keeps the flow path from the engine to the cooler very short. As the engines get larger (or the installations become more complex), this vertical core and close-coupled fan arrangement may no longer be the best fit. However, among the many configurations of radiators or air coolers in use, at their core the design and construction are often very similar.

To pass heat from the coolant to the air requires a design that maximizes the convection heat transfer to the air. Simply running the coolant through tubes will allow the heat to pass from coolant to air through free convection, but the heat flow rate for that process is not enough for an engine. By adding a fan to drive the air across the tube we increase the rate of heat transfer significantly, but it is still not enough to cool the engine. The final piece is to have enough surface area for the moving air to extract the heat at the rate the engine requires. To do this, radiators split the coolant flow across many tubes, then surround the tubes with very thin metal fins. In this manner the heat flows from the coolant into the metal of the tubes and further out into the fins. The moving air can then carry heat away from all of these surfaces, making heat transfer tremendously more efficient.

Types of External Cooling Systems

The finned-tube construction can take several forms, with the most common seen in Figure 3.3. Smaller radiators may use flat tubes interconnected by folded metal fins. Larger coolers may apply the fins directly to round tubes to address issues of strength and modularity (ability to scale the cooler to suit specific projects). Large amounts of heat generated by a large engine requires a very large number of finned tubes in the cooler. To minimize the overall size of the cooler, groups of tubes are assembled into bundles; to distribute the coolant flow among the tubes they are joined together on each end by headers. These assemblies of tube bundles and headers form the various sections or cores that make up the overall cooler. Large, multiple core radiators or coolers can also incorporate other features or accessories, such as:

- bug screens or hail guards to protect the finned tubes from damage or fouling
- louvers to help regulate temperature in cold conditions
- bearings, supports, and drives for the fan
- shrouds or ducting to direct air flow through (and not around) the cores

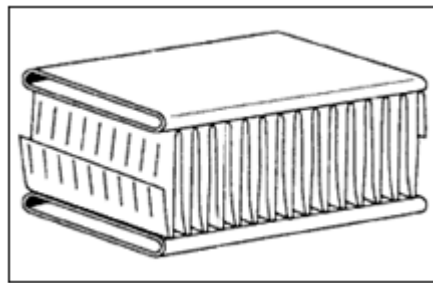

Figure 3.2 — Example of flat tube radiator/cooler construction.

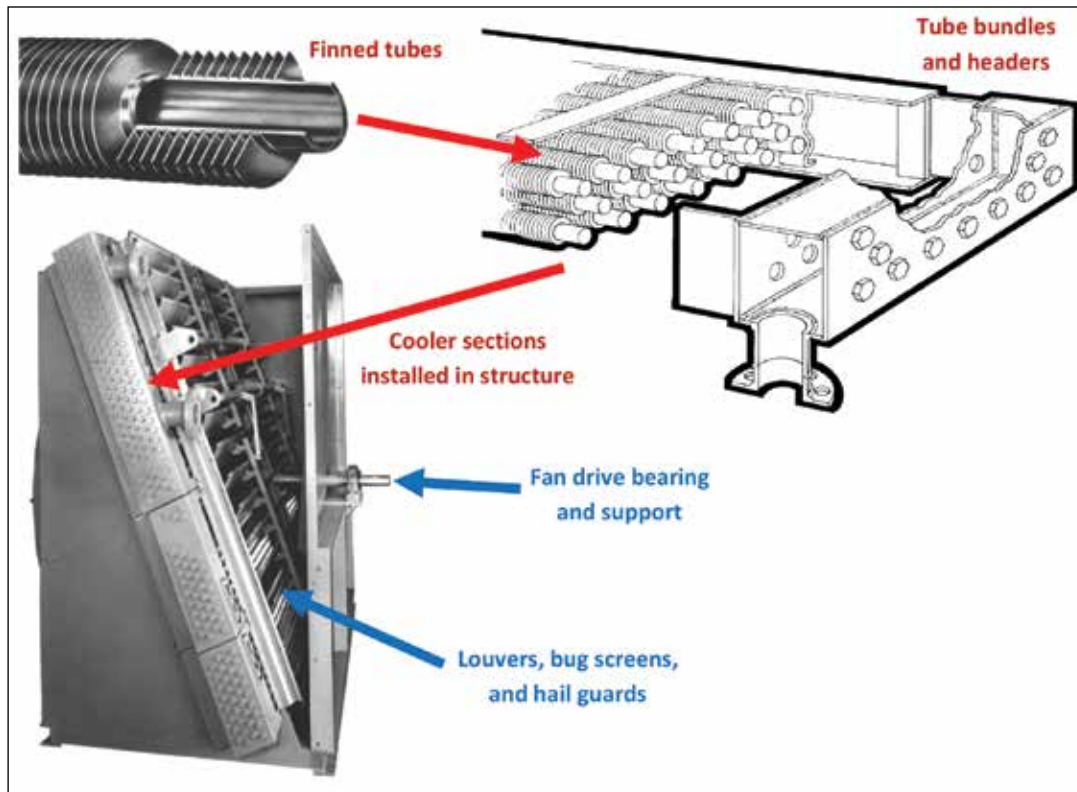

Figure 3.3 — Round tube cooler construction and accessory features.

3.1.1 Vertical Radiator/Cooler

The vertically-oriented core is what is commonly known as a radiator. Radiators are commonly seen on applications where the engine is the only process that must be cooled. They may be constructed as a single core for a single circuit engine cooling system or with a split core to support separate-circuit engine designs (see Figure 3.4). In many cases the expansion volume is designed into the top tank of the radiator, and in this manner the coolant flowing downward through the radiator core also provides the static pressure on the pump inlet without the use of a separate shunt line. By mounting the radiator very close to the engine, a direct mechanical drive arrangement is possible for the cooling fan. To maximize the air flow through the core, the fan is surrounded by a shroud. Vertical radiator designs are very common on generator sets and in vehicular applications. This type of radiator is typically the design of choice until vertical size, the number of cooling circuits required, or site layout limitations force the selection of a different type of cooler.

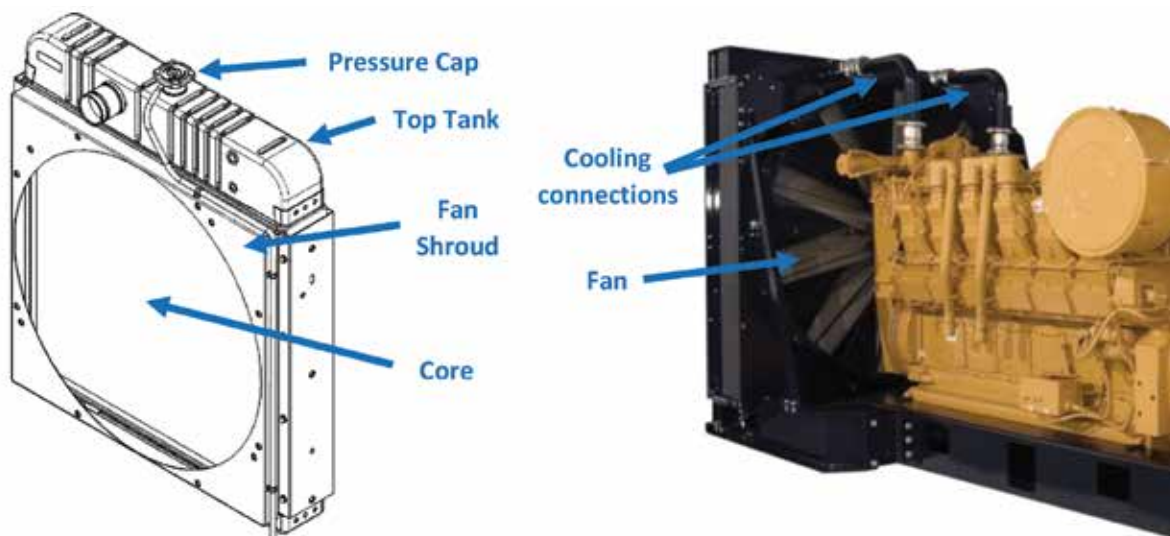

Figure 3.4 — Details of the radiator cooled system.

A variation on this theme is the vertical air cooler, which differs from the radiator by the inclusion of additional cores to cool processes other than the engine's cooling circuits. A very common application of the air cooler is in gas compression, where the gas compressed by the package must be cooled before moving to the next stage in the process. An example of such a cooler is shown in Figure 3.5. Note the number of distinct cooler cores visible on the side of the enclosure. Only the top two sections are for the engine's cooling circuits; the others are for the natural gas being compressed in this application. The construction of this type of cooler is similar to that in Figure 3.3, shown earlier.



Figure 3.5 — Gas compressor package with vertical air cooler. For a size reference, note the service technician directly beneath the exhaust stack at engine rear.

Horizontal Cooler

The horizontal cooler is a repackaging of the radiator or air cooler discussed above. It is really no different than the radiator in its function, except the cooling cores and fans have been reoriented, with the cores lying flat to the ground and the fans placed to work with that orientation. The horizontal layout for the cooling cores allows the design to manage vertical height by spreading the face area over a wider horizontal footprint. The cooling fans may be direct-driven or motor-driven, and as a result may be vertical (as shown) or horizontal, mounted parallel to the cooling cores themselves. Multiple large stages are often more easily packaged into a horizontal layout.



Figure 3.6 — A horizontal cooler on a G3600 Gas Compression Engine installation. Note the multiple stages to support cooling for the engine and the compressor gas.

Types of External Cooling Systems

In the example shown in Figure 3.6 the horizontal cooler cores are located at the top of the structure. The fans (there are three here) are vertically oriented, driven by a single shaft running through the structure back to the engine inside the building in the background. The diagonal enclosed space behind each fan are turning vanes that direct the air flow from the fans up through the cores. Another common horizontal core design places the fan in a horizontal orientation directly beneath each set of cores. For this design the fans are driven by electric motors. Coolers with motor-driven fans do not need to be located in immediate proximity to the engine; when they are located away from the engine they become *remote-mounted* radiators/coolers.

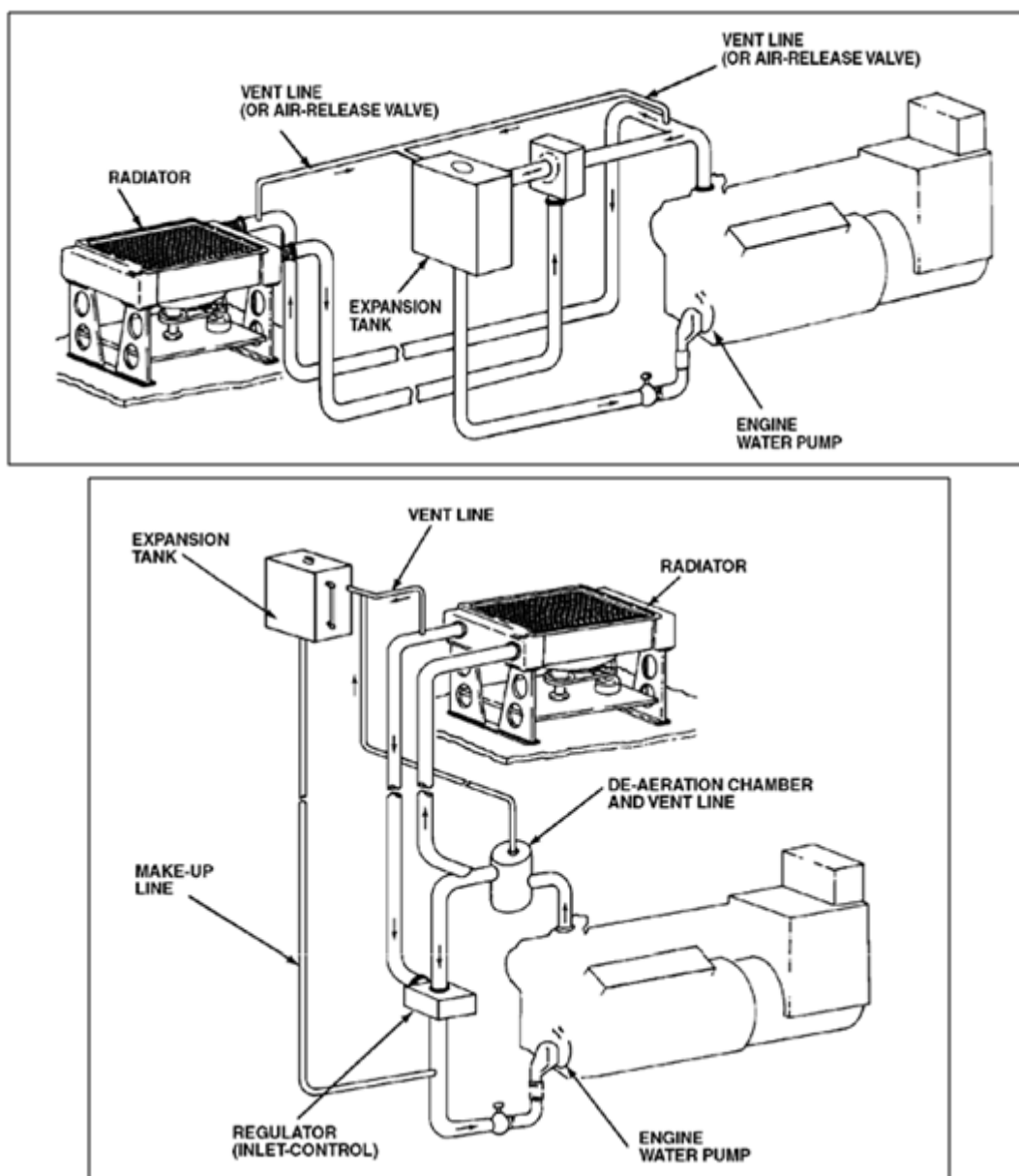

Figure 3.7 — Examples of remote horizontal core radiators. The upper image shows a remote installation level with the engine. The lower image is typical of a roof-mounted unit. Both use motor-driven fans. Note the location of the expansion tank as the highest point in the system. Radiators mounted above the engine are subject to height limits due to static pressure rise.

Types of External Cooling Systems

Remote-mounted radiators add tremendous flexibility to installations where a close-mounted unit simply will not work. Circumstances that may drive consideration of a remote installation include lack of floor space adjacent to the engine or inadequate access to air to circulate through the core for cooling. Generator sets located inside buildings will often use radiators mounted outside the building, both for access to cool air and to ensure the heated air passing from the radiator has a path to exit the area. However, remote radiators do introduce other considerations that should not be overlooked.

- Distance from the engine adds to the total length of interconnect piping, which adds to the system's total restriction to flow. Keeping the total restriction within the acceptable limits for the engine's coolant pumps can be challenging, forcing changes to larger diameter pipe or other such design options. If piping design alone is not sufficient to reach an acceptable solution, it may be necessary to replace the standard engine-driven pump with an electric motor driven pump sized for the task. Note that using a larger pump to overcome high system restriction means the peak system pressure will be higher. Always verify all system components are rated for the operating pressure your design will use.
- Radiators mounted above the engine introduce height as a consideration for the pressure of the coolant column on the engine's pump. The weight of the full column of coolant exerts pressure on the coolant pump, even without the engine running. If this column gets too tall, the static pressure that results can exceed the rated capability of the pump seals. A rough rule of thumb is to limit the height of the coolant to less than 17.4 m (57 ft) above the pump. For installations that come close to this limit, it is recommended the static and dynamic pressures of the design be compared against the pump's limits to ensure satisfactory operation.
- For designs that place the engine above the radiator height limit, considerations apply as well, but in such a case the issue is the pressure capability of the radiator and not the pump. Similar to the discussion above, every 610 mm (2 ft) of vertical difference adds roughly 6.9 kPa (1 psi) to the static pressure at the bottom of the fluid column. All devices and piping located at the bottom must be constructed to accommodate this static pressure, plus the dynamic pressure rise produced by the circulating pump.
- Systems that use a remote expansion tank (see lower example in Figure 3.7) must include a deaeration chamber near the engine outlet with vent lines extending to the expansion tank. Because the full coolant flow does not pass through the expansion tank there is little opportunity for entrained air/gas to escape the flow. That opportunity must be created by including a deceleration zone in the flow path.

3.1.2 Radiator Fans

As mentioned earlier, the radiator doesn't become an effective external cooling solution without the fan. Driving the air through the cooler core is an essential part of achieving the performance capability of the radiator, so the fan installation deserves as much consideration as the sizing of the core itself.

For vertical core installations, the fan is commonly located between the radiator and the engine. In most cases this is a matter of practicality because the fan is being driven by a mechanical linkage to the engine so proximity has its advantages. However, even for installations using a motor-driven fan, this arrangement may be best as the relationship between the radiator and engine can be used to create a safety zone around the fan, limiting the opportunity for personnel to put themselves near the moving components and in danger. The fan will almost always be placed close to one surface of the radiator core to maximize its effectiveness at moving air through the core. Since the core poses some restriction to air flow, air will try to "cheat" past the core. Keeping the fan close to the core and using appropriately designed shrouds (see discussion below) are key to maximizing air flow performance of the fan.

Types of External Cooling Systems

Variables to consider in the selection of a fan include the diameter, number of blades, blade shape, blade pitch, rotation speed, and air flow direction. Each of these parameters is influenced, either directly or indirectly, by the environment and application for the engine. Consider the following:

- The air flow direction determines the direction of movement of the heat being rejected. A *suction* fan, which pulls air toward the engine, is often used in mobile equipment because the forward movement of the vehicle helps to force air through the radiator. However, the suction fan layout drives the heated air around the engine, making it undesirable for large stationary installations where personnel servicing the site would be forced to work in a high temperature space as a result. A *blower* fan pulls air across the engine, pushing it through the radiator and away from the installation. This type of fan allows for a more comfortable work space for servicing personnel as the heated air is driven away from the engine and, for enclosed installations, outside of the building.
- The fan diameter is largely determined by the cooler size which, in turn, results from any restrictions in the site layout. Sites that can support tall coolers may use very large diameter fans, while more restricted spaces may drive the need to limit fan diameter. For mechanically-driven fans, the fan diameter is also a function of the operating speed of the engine. Engines with higher operating speeds will push the range of reasonably achievable fan speeds higher, driving the need to limit diameter. Ultimately, the fan tip speed must not exceed its manufacturer's published limits or it may lead to failure.
- The number of blades, blade shape, and blade pitch are typically determined by the fan manufacturer. These three parameters, combined with rotation speed, determine the air flow potential of the fan and the power required to drive the fan.
- The fan speed, number of blades, blade shape, blade pitch, and the clearances of the tip (to the surrounding shroud) and the fan (to the surface of the radiator core) all have an impact on the noise generated by the operation of the fan. The pitch of the fan blade is closely related to the blade angle, so much so they are often used interchangeably. Some resources will point out the pitch of the fan is functionally the rate of axial air movement per revolution of the fan expressed in terms of a fan size measurement, such as hub diameter. For purposes of engine cooling installations, it is a fan design parameter that is already taken into account by the cooler supplier and need not be considered in depth by the user. It is important the fan operate at the specified rotational speed (hence engine speed AND pulley ratio) to ensure proper fan performance and blade tip speed.

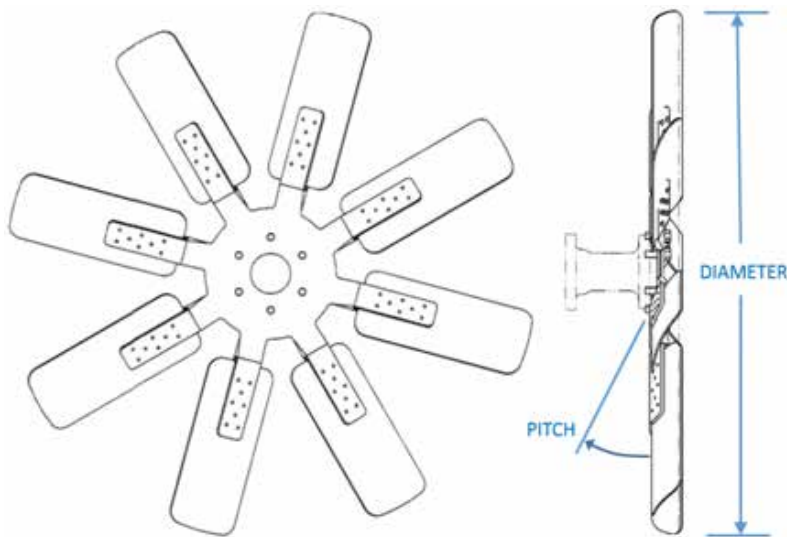

Figure 3.8 — Radiator fan design parameters, including diameter, blade angle or pitch, and number of blades.

Types of External Cooling Systems

A properly sized and fitted shroud is also important to the performance of the fan and the radiator. Among the important contributions of the shroud are maximizing air flow across the entire radiator core and reducing noise resulting from vortices generated at the blade tip. With no shroud the fan will draw air primarily in the circular region directly in front of its swept diameter. There is much air leakage around the blade tips that diminishes the air flow drawn through the radiator core. By fitting closely to the rotating radius of the blade tips, a shroud greatly reduces leakage and allows the fan to create a pressure zone behind the shroud across the entire radiator surface. This pressure zone drives air flow across the entire radiator core to achieve the best heat exchange performance for that core size. The close-fitting shroud also limits the development of spiraling vortices from the passing fan blade tips, lowering the noise profile of the fan installation since tip vortices are a significant source of noise.

Just as the shroud affects the air flow directed through the core, any obstructions placed near the air flow on either side of the radiator can affect the air flow performance as well. Structures or features (such as guards, bumpers, grilles, shutters, or even engine-mounted accessories) that get too close to the fan can cause irregularities in the air flow field. Those irregularities in flow create uneven forces on the fan that can affect the air flow performance of the installation or, even worse, create conditions that promote oscillations in the fan. Left uncorrected, such oscillations could result in a fatigue-related fan failure. A scalable rule of thumb for such obstructions is to have them no closer to the fan surface than 8% of the fan's outer diameter.

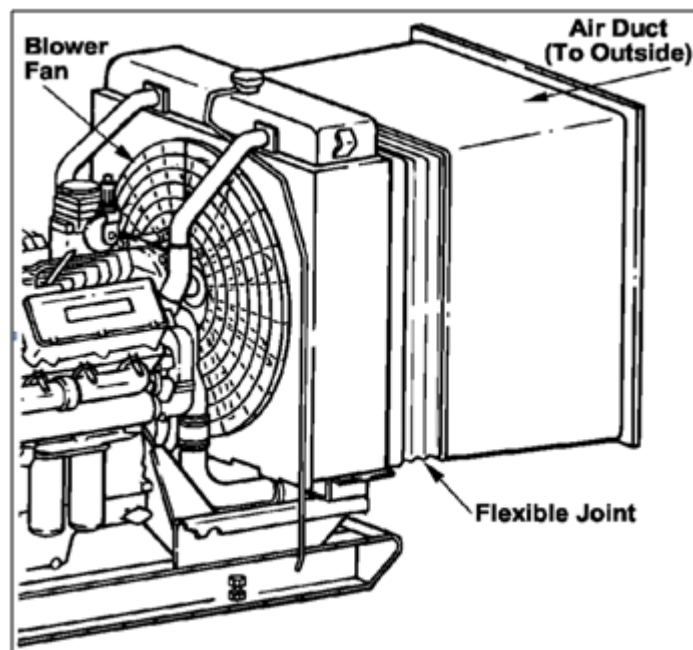

Figure 3.9 — A close-mounted radiator installation, showing a close-fitting fan shroud and radiator air outlet ducting. Such ducting can add air path restriction and should be considered in the overall performance calculations for the radiator. Ducting also serves as a conduit for noise transmission, both through the air path and in the duct walls. The flexible joint shown helps isolate the engine from the ducting for both vibration and noise transmission through the structure.

Even more uniform surfaces can affect flow restriction and development. Solid walls perpendicular to the air flow direction that are closer than two fan diameters from the flat face of the radiator can restrict or alter air flow to the radiator. Solid walls (or ducting) parallel to the air flow direction should have inner dimensions larger than that of the radiator core they serve to avoid adding restriction and/or necking of the air flow near the radiator.

If louvers are added for protection of the radiator, the inner cross-sectional area of the ducting from the louvers to the core should be increased by 25% over the core width-times-height dimensions. For moveable louvers, actuated designs (mechanical, electric, or pneumatic) are strongly preferred over the passive type intended to be opened by the pressure of the radiator fan air flow. Passive louvers can be rendered inoperative by rain, ice, and snow, and their failure to open will lead to temperature-related shutdowns. Common window screening is generally considered not suited for use to provide protection from ingestion of small objects at the air inlet, as such screening poses a relatively high restriction to air flow. If it is used, the air supply opening area should be increased by 40% to help minimize the resulting restriction losses. In general, the total restriction to air flow posed by all features (ducting, walls, screens, louvers, etc.) should be limited to 12.7 mm (0.5 in) of water column.

3.1.3 Site Layout for Radiator-Cooled Engines

The site layout for radiator-cooled engines must also be configured to avoid ingestion of heated radiator exhaust air (or even engine exhaust) into other critical air intakes, including engine air intakes and other radiators. While especially true for multi-engine installations, even single units can run into problems from reingestion. Figure 3.10 below shows a few such possibilities for recirculation/reingestion to help visualize what must be considered for each specific site.

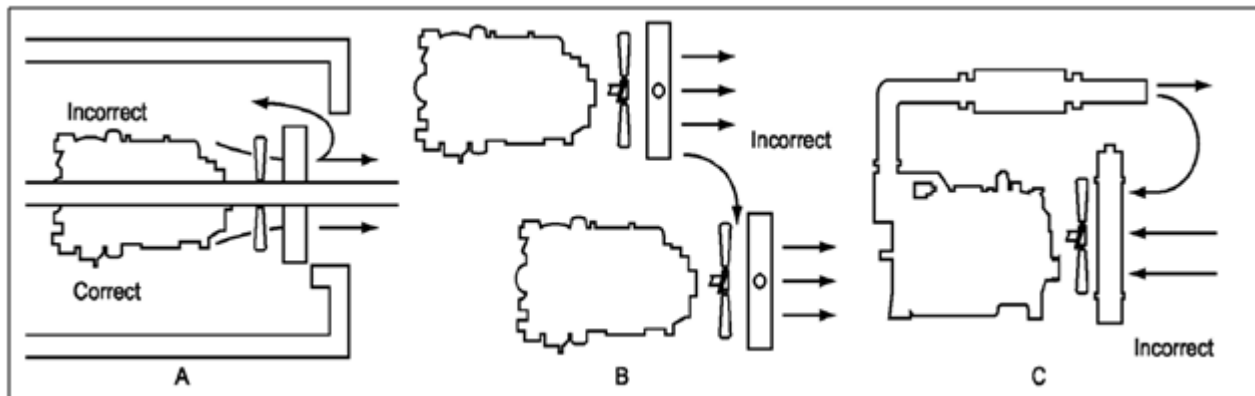

Figure 3.10 — Examples of radiator air flow patterns that can lead to issues with recirculation/reingestion of heated exhaust streams.

Example A shows how a simple extension of the wall at the radiator exhaust opening of the engine enclosure can prevent heated outlet air from returning to the engine enclosure. Example B shows how dispersion of the outlet flow can become ingested if the units are staggered relative to one another or to the prevailing wind patterns of the site. Example C shows a suction fan installation with a misplaced engine exhaust outlet that allows hot exhaust gases to join with the planned radiator air flow.

Site prevailing wind patterns should be considered when orienting the radiator and engine exhaust flows in general. Having the radiator air outlet directed into the wind diminishes the effective air flow from the fan and will lead to overheating when the winds are strong enough.

Types of External Cooling Systems

3.1.4 External Cooling System Sizing

The heat transfer rate of the radiator must be matched to the heat rejection requirements of the engine/rating and the anticipated design of the external cooling system. A methodical process is established to sum the total heat rejection rate required by each cooling circuit and apply those values to the published flow-restriction charts to evaluate the effectiveness of the design concept to meeting the engine's needs. An overview of the calculation and evaluation methodology may be found in Appendix A and Appendix B.

3.2 Heat Exchangers

A heat exchanger can be used to cool the engine when ventilation air is limited, or when excessive static resistance on the engine must be avoided. Heat exchangers are typically classified according to flow arrangement and type of construction. Advantages to using a heat exchanger include no fan noise, reduced air flow requirements, lowered parasitic load, and improved fuel consumption. When a source of water is readily available, this is an effective method for cooling the engine. As for disadvantages note that a heat exchanger requires a cooling source to which to reject the heat from the engine, which likely means an extra pump and associated plumbing. Provisions for room ventilation will also be required.

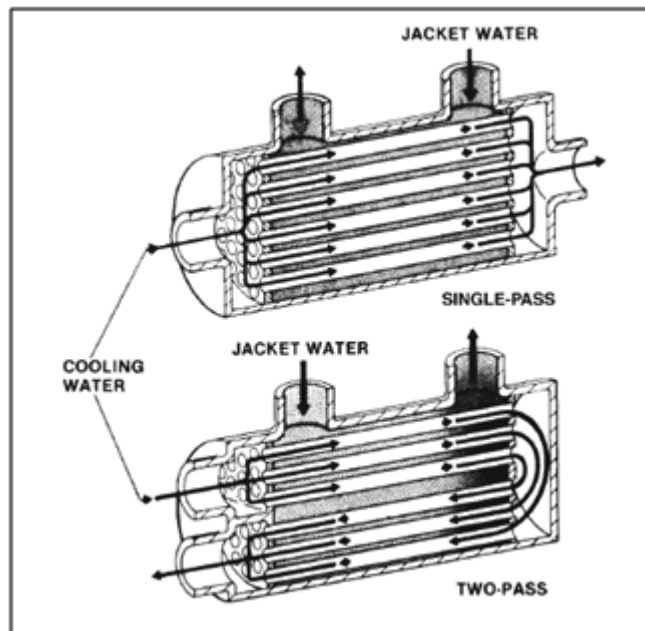

Figure 3.11 — A cross-sectional view showing the internal construction and flow patterns of a shell and tube type heat exchanger. The upper design is considered a “single pass” design, while the lower example is a “two-pass” configuration.

3.3 Shell and Tube Type

The most common type of heat exchanger is the shell and tube type, as shown in Figure 3.11. In a shell and tube heat exchanger, the engine coolant is cooled by the transfer of heat to another liquid at a lower temperature. The design parameters available to the shell and tube heat exchanger designer include the diameter, length, number of tubes, the number of raw or treated water passes, and the number and cutoff height of shell side baffles. These heat exchangers can have single-pass or multiple-pass flows. A single pass heat exchanger has the cooling media pass through the heat exchanger only once before exiting. A multiple-pass heat exchanger allows cooling media to pass through the heat exchanger multiple times before exiting. The engine coolant is usually piped to flow through the shell side so that the raw water flows through the tubes. This permits the raw water side to be readily cleaned by mechanical means.

Most shell and tube heat exchangers are either the single-pass or the two-pass type. This designation refers to the flow in the cold water circuit of the exchanger. In the two-pass type, the cold water flows twice through the compartment where jacket water is circulated; in the single-pass type only once (see Figure 3.11). When using a single-pass exchanger, the cold water should flow through the exchanger in a direction opposite to the flow of jacket coolant to provide maximum differential temperature and heat transfer. This results in improved heat exchanger performance. In a two-pass exchanger, cooling will be equally effective using either of the jacket water connection points for the input and the other for return.

The direction of flow of the raw water will affect the heat transfer from the engine's coolant. In a single-pass heat exchanger the raw water can flow in the same direction as the coolant (parallel flow) or it can flow in the opposite direction as the coolant (counter flow). A heat exchanger can transfer more heat when connected for counter flow than it can using parallel flow. For this reason most shell and tube heat exchangers use counter flow.

For a given jacket water flow rate, the performance of a heat exchanger depends on both the cold water flow rate and differential temperature. To reduce tube erosion, the flow rate of the cold water through the tubes should not exceed 183 cm/s (6 fps). The heat exchanger should be selected to accommodate the cold water temperature and flow rate needed to keep the temperature differential of the jacket water below about 8.3°C (15°F) at maximum engine heat rejection. Thermostats must be retained in the jacket system to assure that the temperature of the jacket water coolant returned to the engine is approximately 79°C (175°F).

Heat exchangers should be sized to accommodate a heat rejection rate approximately 10% greater than the tabulated engine heat rejection. The additional capacity is intended to compensate for possible variations from published or calculated heat rejection rates, overloads, or engine malfunctions which might increase the heat rejection rate momentarily. It is not intended to replace all factors which affect heat transfer, such as fouling factor, shell velocity, etc. These factor addition needs should be evaluated for the application.

Occasionally, special applications exist which require an inboard heat exchanger size not available as a Cat unit. When these conditions exist, it is necessary to obtain a heat exchanger from a supplier other than Caterpillar. Heat exchanger suppliers will provide information and aid in selecting the proper size and material for the application.

Since heat exchanger tubes can be cleaned more easily than the surrounding jacket; the cold water usually is routed through tubes and the engine coolant through the shell.

3.4 Plate and Frame Type

Another common type of heat exchanger is the plate type heat exchanger, as shown in Figure 3.12. The design parameters available to the plate type heat exchanger designer include the size and number of plates, the turbulator design, and the number of raw or treated water passes. Tight baffling around the heat exchanger is critical to obtaining good heat transfer performance.

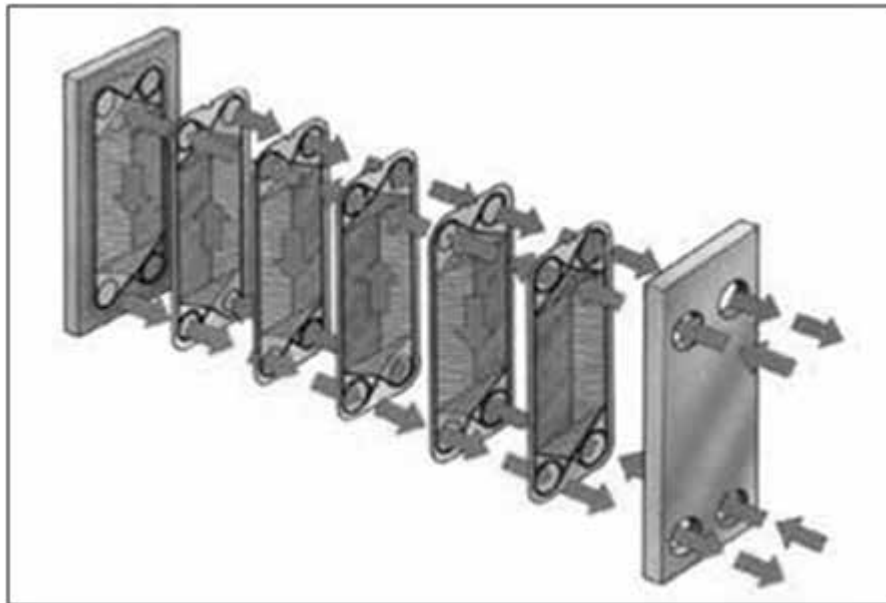

Figure 3.12 — Construction and flow paths for a typical plate and frame type heat exchanger.

3.5 Design Criteria and Considerations

Many engine models have attachment heat exchangers in the price list. Consider the following factors when designing and installing a heat exchanger cooling system.

Size the heat exchanger to accommodate a heat rejection rate approximately 10% greater than the engine's heat rejection. The additional 10% will compensate for possible variations from published or calculated heat rejection rates and engine overload.

The cooling capacities vary for different cooling mediums and tend to reduce heat transfer. A fouling factor is assumed during equipment sizing, which will affect the heat transfer of a heat exchanger. Factors for common types of water can be found in Figure 3.12.

The fouling factor relationship is:

$$FF = [(1/UCoolant) - (1/UClean Core)]$$

Where:

FF = Fouling factor, hr-m²-°C/kJ (hr- ft²-°F/Btu)

UCoolant = Heat Transfer Coefficient of core with coolant, kJ/hr-m²-°C (Btu/hr-ft² °F)

UClean Core = Heat Transfer Coefficient of clean core kJ/hr-m²-°C (Btu/hr-ft² °F)

For the coolants listed in Figure 3.13, fouling factors greater than 0.001 will result in significant change in the heat transfer capacity. Use Figure 3.13 to correct the heat capacity of the heat exchanger given in TMI for fouling factor different from the base of 0.001. For coolants with fouling factors less than 0.001 the values have been left unchanged. Caterpillar does not recommend designing for a fouling factor less than 0.001.

Types of External Cooling Systems

Fouling Factor Chart for Water ($hr \cdot ft^2 \cdot F/Btu$)		
Engine Coolant Temperature < 116°C (240°F) Raw Water Temperature < 52°C (125°F)		
Water Types	Raw Water Velocity	
	≤0.9 m/s (3 ft/sec)	>0.9 m/s (3 ft/sec)
Seawater	0.0005	0.0005
Brackish Water	0.002	0.001
Cooling Tower and Artificial Spray Pond: Treated Makeup Spray Pond: Untreated	0.001 0.003	0.001 0.003
City or Well Water (such as Great Lakes)	0.001	0.001
River Water	0.003	0.003
Hard (over 15 grains/gal)	0.003	0.003
Engine Jacket	0.001	0.001
Treated Boiler Feedwater	0.001	0.0005

Note: $1 hr \cdot ft^2 \cdot F/Btu = 0.0545 hr \cdot m^2 \cdot C/kJ$

Fouling Factor Chart Correction Factors		
Engine Coolant Temperature < 116°C (240°F) Raw Water Temperature < 52°C (125°F)		
Water Types	Raw Water Velocity	
	≤0.9 m/s (3 ft/sec)	>0.9 m/s (3 ft/sec)
Seawater	1.0	1.0
Brackish Water	0.83	1.0
Cooling Tower and Artificial Spray Pond: Treated Makeup Spray Pond: Untreated	1.0 0.71	1.0 0.56
City or Well Water (such as Great Lakes)	1.0	1.0
River Water	0.71	0.71
Hard (over 15 grains/gal)	0.71	0.56
Engine Jacket	1.0	1.0
Treated Boiler Feedwater	1.0	1.0

Figure 3.13 — Fouling factor charts.

If solenoid valves are used to control cooling water, position them upstream of the heat exchanger. The drain for the heat exchanger is always open and the heat exchanger is relieved of pressure when inoperative. If solenoid valves are installed on both sides, raw water could be trapped in the tubes if the solenoids fail to open. Water trapped during engine operation expands and could rupture the exchanger. All solenoid valves should include a manual bypass.

Do not add temperature regulators in raw water supplies. Engine jacket water is controlled by a temperature regulator; additional controls add expense, restriction, and decrease reliability.

3.6 Jacket Water Heat Exchanger Sizing

Occasionally, special applications exist which require an inboard heat exchanger size that is not available from Caterpillar. When these conditions exist, it is necessary to obtain a heat exchanger from a supplier other than Caterpillar. In order to expedite the selection of a nonstandard heat exchanger, a Heat Exchanger Selection Worksheet is provided in this guide in the reference section at the end; heat exchanger suppliers will provide information and aid in selecting the proper size and material for the application.

For a given jacket water flow rate, the performance of a heat exchanger depends on both the cold water flow rate and differential temperature. To reduce tube erosion, the flow velocity of the cold water through the tubes should not exceed 183 cm/s (6 fps).

At the same seawater flow rate, the flow resistance and the flow velocity will be greater through a two-pass heat exchanger than through a single-pass heat exchanger. The heat exchanger should be selected to accommodate the cold water temperature and flow rate needed to keep the temperature differential of the jacket water below about 8.3°C (15°F) at maximum engine heat rejection. Thermostats must be retained in the jacket system to assure that the temperature of the jacket water coolant returned to the engine is approximately 79°C (175°F).

Types of External Cooling Systems

Size heat exchangers to accommodate a heat rejection rate approximately 10% greater than the tabulated engine heat rejection. The additional capacity is intended to compensate for possible variations from published or calculated heat rejection rates, overloads or engine malfunctions which might increase the heat rejection rate momentarily. It is not intended to replace all factors which affect heat transfer, such as fouling factor and shell velocity.

Pay particular attention to the shell side pressure drop to ensure that the entire cooling system flow resistance does not exceed the limitations of the engine's freshwater pump.

3.7 Aftercooler Heat Exchanger Sizing

The aftercooler heat rejection data in the TMI is for standard conditions of 25°C (77°F) and 150 m (500 ft) altitude. This data meets all standard conditions for SAE J1349, ISO 3046, DIN 6271, BS 5514, and API 7B-1 IC.

Ambient temperature higher than standard will raise the amount of heat in the inlet air needing to be rejected to the aftercooler circuit. Altitudes higher than standard will require a higher pressure ratio across the turbocharger (i.e. the turbocharger works harder) to obtain the rated absolute pressure in the intake manifold. Higher pressure ratios result in more heat of compression and more heat rejected to the aftercooler circuit.

For ambient temperatures and altitudes above standard conditions, the aftercooler must be enlarged to dissipate the additional heat described in the above paragraph. To properly size the aftercooler for a specific ambient and altitude, it is necessary to multiply the heat rejection at standard conditions by a multiplier. These multipliers (between 1.0 and 3.0) are for a combination of the ambient and altitude and are found in the "Aftercooler Heat Rejection Factors" charts. Heat rejection data and the multipliers, as well as the air flow and compressor outlet pressure, can be found in TMI or the performance and technical information books for each engine family.

Since the altitude and ambient temperature deration curves are designed to be used with a known water circuit temperature, some effort must be put into converting the air temperature from the aftercooler, to a water circuit temperature. To convert for a maximum air temperature from the ATAAC to SCAC temperature, simply subtract 11.3°C (20°F) from the outlet air temperature of the ATAAC. For example, if the cooled air is 93.3°C (110°F), use the 32°C (90°F) engine horsepower rating. If the cooled air is 54°C (130°F), use the 43.3°C (110°F) engine horsepower rating.

Failure to compensate for the actual air inlet temperature can cause detonation and result in engine shutdown or failure.

To obtain the turbocharger compressor outlet temperature for other than standard conditions, use the formula listed below:

Actual Compressor Outlet Temperature = Aftercooler Heat Rejection Factor x [Compressor Outlet Temperature Standard Condition - 43°C (110°F)] + 43°C (110°F)

3.8 Cooling Towers/Evaporative Coolers

Radiators rely on a difference of the ambient air temperature over the design coolant outlet temperature. For applications in a temperate climate that require very cool water, or for more conventional applications in a very hot climate, it may not be possible to achieve the target coolant temperature through convection alone. The coolant-to-air temperature difference (the approach temperature) simply doesn't support it. In such circumstances, the first alternative is to seek an existing source for cool water, such as a river or lake. When this alternative is not available, the next option is to use evaporation to achieve heat transfer.

Evaporation is the process by which a liquid is transformed into a gas. A large amount of heat energy is needed to achieve this change of state of the fluid. This heat quantity, the *latent heat of vaporization*, is the key to evaporative cooling processes and their ability to reject heat even when the available approach temperatures don't support more conventional convection coolers.

Rather than just the ambient temperature, evaporative cooling relies on the relative humidity of the ambient air for performance. Relative humidity is a measure of the saturation of the air with water. In technical terms it is the ratio of the partial pressure of the water vapor in the air to the equilibrium vapor pressure of water at the same temperature. In a practical sense it is a statement of how readily additional water can be evaporated into the air. A relative humidity of 100% indicates the air is saturated with water vapor and cannot accept more, which is why this measure is a key consideration for evaporative cooler performance. Evaporative performance is definitively tied to the ambient temperature and barometric pressure of the air at the site. Discussions on the water saturation property of the ambient air may use other terms as well:

- Dew point = The temperature at which water vapor in the air condenses or evaporates at the same rate. The dew point is the saturation temperature of water vapor in the air at the current barometric pressure, thus relative humidity is 100% when the ambient air is at its dew point.
- Wet bulb temperature = The ambient temperature when measured by a wet-bulb thermometer, a thermometer with the sensing bulb covered with a wetted fabric to allow evaporation to cool the bulb. The difference between this wet bulb temperature and the dry bulb temperature is a measure of the relative humidity or the air.

As a relative measure, consider that an evaporative cooler may produce 75% of its cooling through evaporation, with the other 25% occurring in the normalization of the temperature difference between the water and air. The ability of the air to absorb moisture is critical to its effectiveness; when the air cannot absorb additional moisture there will be no evaporation and little cooling. Evaporative cooling can be incorporated into the cooling loop in simple ways. Even evaporation of water from the hot external surfaces of the radiator increases the heat rejection rate. However, it is not recommended to spray water on a radiator that is not configured for evaporation as it can actually damage the cooler. Instead, an evaporative cooler should be designed specifically to that use. Large scale evaporative cooling is best exemplified by the cooling tower.

As a general rule, cooling towers are most practical in areas with typical ambient dry-bulb temperatures above 38°C (100°F) and relative humidity of 50% or less. As with convective coolers (radiators), the design of a cooling tower is dependent upon the approach temperature, although in the case of the evaporative design, the approach temperature is the difference between the target coolant temperature and the ambient wet bulb temperature. The same rule of diminishing returns applies, however. To go from a design approach temperature of 8.3°C (15°F) to 5.6°C (10°F) may require an increase in tower size of 50%. Any approach temperature of less than 2.8°C (5°F) becomes unrealistic.

Cooling tower applications do require a water source. Evaporation means the liquid water will exit the process as water vapor escaping to the ambient air, and in this manner that water becomes a consumable for the process. This may limit tower use in areas where water is not readily available.

Types of External Cooling Systems

Cooling towers can be generalized into two categories, open- and closed-loop. Each has its advantages and disadvantages, but a couple of key considerations make the open design undesirable for engine cooling. In the open system the coolant itself is evaporated in the air. The cooling system is thus “open” to the environment, as the circulating loop must be interrupted to accomplish the evaporation key to this design. The continued process of evaporation means that any scale-forming salts present in the water will gradually be concentrated, and the water may pick up further contaminants from the air. These impurities can result in the buildup of scale on the walls of the cooling water passages in the engine, decreasing the cooling efficiency and increasing the possibility of overheating. As a general rule, *open cooling systems are not recommended for Cat engines.*

In circumstances where an open design is necessary, specific design considerations must be put in place to adapt the engine to the hazards of the open cooler. Some engines can be equipped with corrosion resistant piping and a cleanable aftercooler core, with the round tube design of the aftercooler enabling much simpler disassembly and cleaning than with the designs normally used. An open tower design can be adapted to engine use by isolating the engine with a heat exchanger, as shown in Figure 3.14. The heat exchanger maintains the engine’s closed cooling loop, eliminating the concerns of the open tower for the engine. The cost of this compromise is the addition of the approach temperature of the heat exchanger to the design profile of the cooling solution. That added step of heat exchanger increases the return temperature that can be achieved in the engine’s cooling loop.

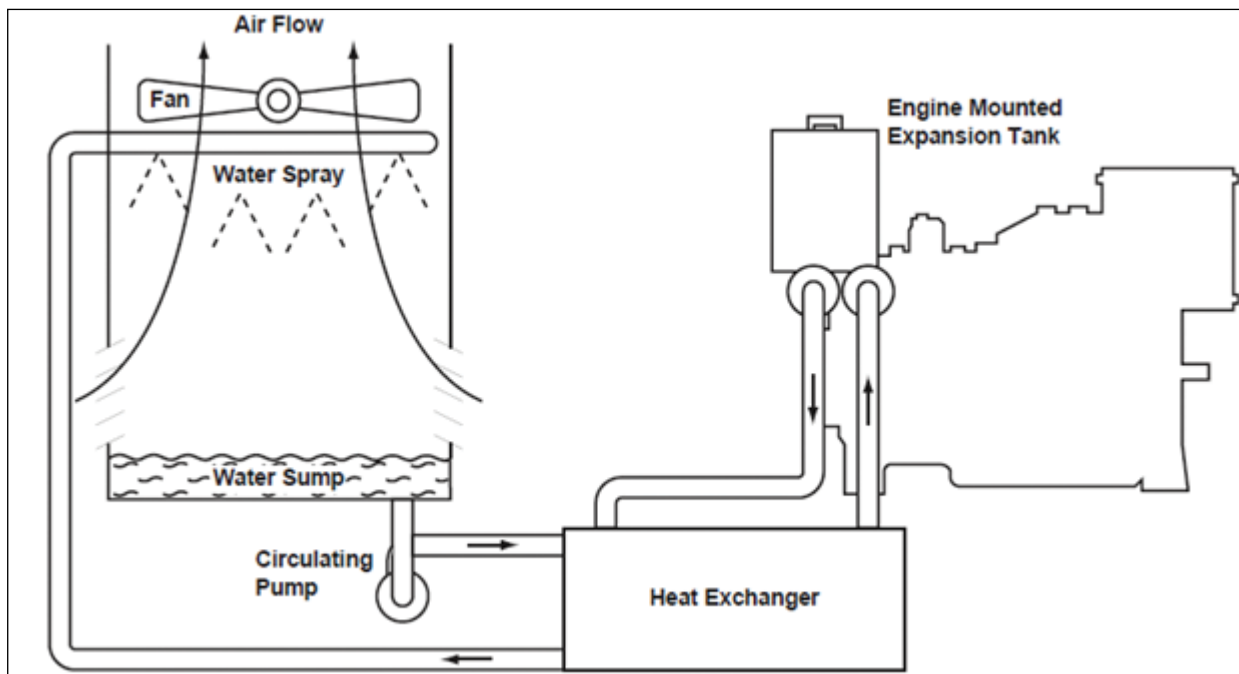

Figure 3.14 — Open cooling tower with heat exchanger isolation for the engine.

By contrast, a closed cooling tower interacts with the engine much more like the other closed systems (radiators, heat exchangers) described earlier. The coolant circulation path is not open inside the tower, but instead is maintained closed through the tower, as seen in Figure 3.15. Evaporative cooling is accomplished in a separate fluid loop within the tower and not by the evaporation of the engine coolant itself. This design does eliminate the need for an isolating heat exchanger to maintain the closed integrity of the engine’s cooling loop.

Types of External Cooling Systems

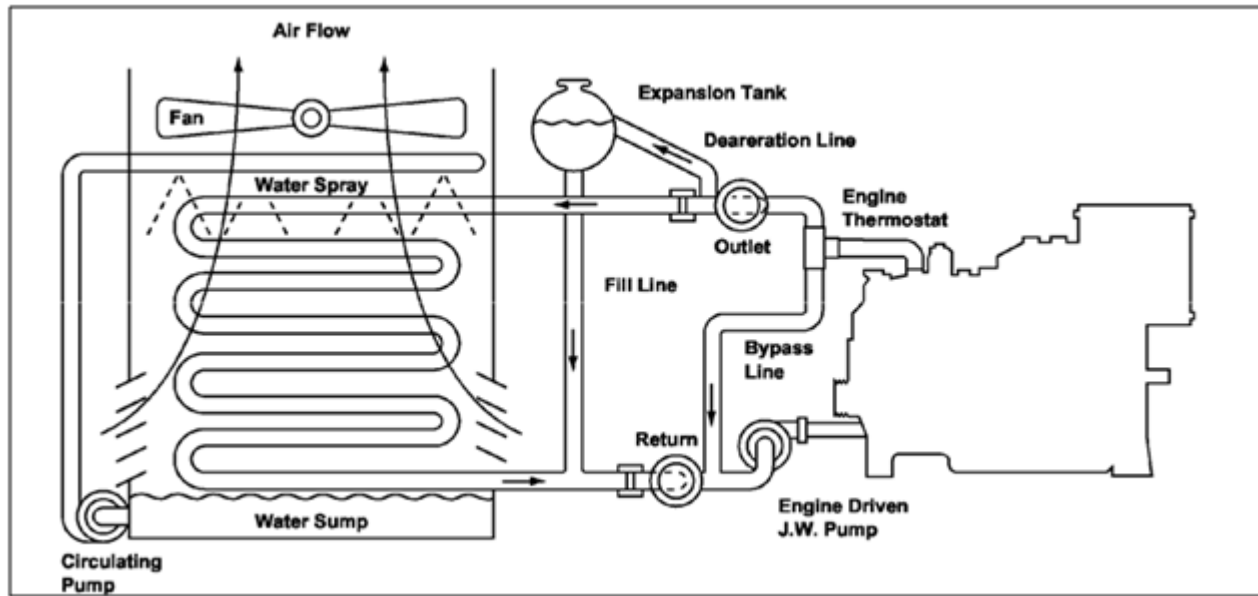

Figure 3.15 — Closed-loop cooling tower.

As with radiators, cooling towers are very sensitive to recirculation. Any recirculation or ingestion of exhaust from another cooling tower effectively reduces the approach and wet-bulb temperature of the incoming air. Factors such as location of the towers, direction of the prevailing winds, and height of the towers (a taller tower will reduce recirculation), should be taken into consideration.

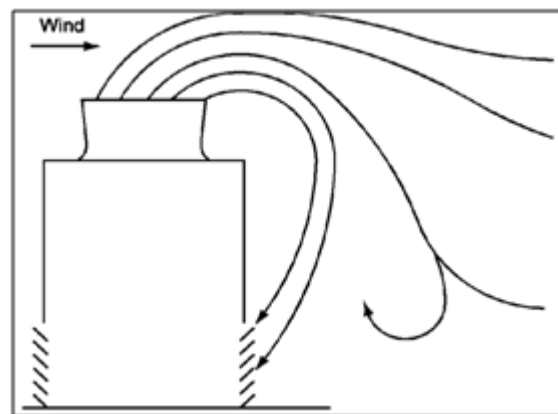

Figure 3.16 — Recirculation of cooling tower outlet flow due to prevailing wind.

Cooling towers installed in frigid locations require additional design requirements to prevent freezing.

4.0 Application-specific Cooling Systems

Some cooling system designs are specifically adapted to the needs and limitations of the application the engine serves. The following sections provide information on cooling system designs for those specialized applications.

4.1 Gen Sets – Hotwell

Hotwell systems are used when static or dynamic head exceeds acceptable limits or when a boost pump imposes excessive dynamic head. Refer to Figure 4.1.

A hotwell tank accommodates total drain back of the remote cooling device and connecting piping. A baffle divides the tank into a hot and a cold side, but is open sufficiently to assure full engine flow. Baffles are also used where water enters the tank to minimize aeration, as shown in Figure 4.1. The baffle shall have sufficient openings to allow the flow of water between the hot and cold sides of the tank. The flow will be the difference in flow rates between the engine-driven and remote pumps.

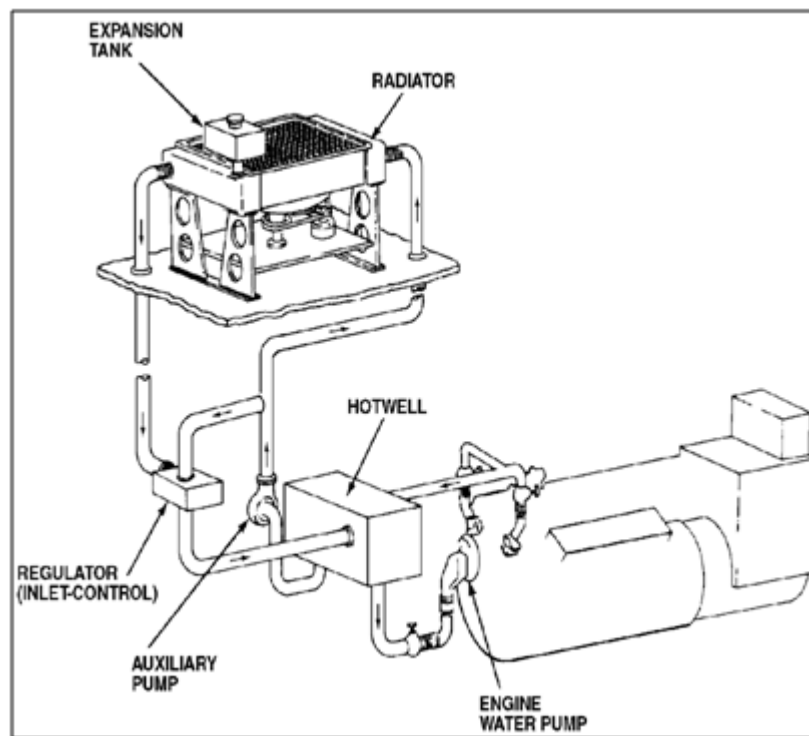

Figure 4.1 — Hotwell system.

If the hotwell does not have sufficient volume, the pumps will draw in air during operation. The hotwell tank must be large enough to accept the full volume of the remote radiator and the interconnecting piping, plus some reasonable amount to prevent air ingestion by the pumps. Generally, 110% of the radiator and piping volume is adequate.

The tank bottom must be above the engine coolant outlet level. The recommended minimum is 0.6 m (2 ft). The auxiliary pump flow must exceed the engine water pump demand. The recommended minimum is 120% of the nominal engine demand at rated speed. Acceptable venting and deaeration of the engine and external circuit must also be provided.

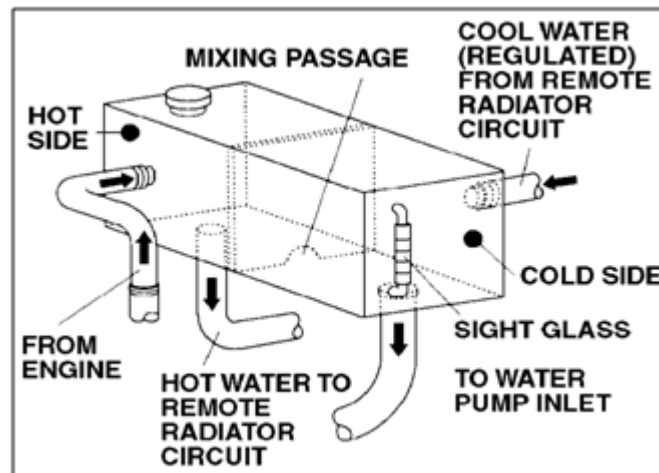

Figure 4.2 — Hotwell tank.

The hotwell must be vented by some means to the atmosphere to reduce the overall system pressure and allow the remote system to drain properly back to the hotwell. Hotwells must be engineered to have proper venting and system pressures evaluated to provide correct system operation. In some cases, it may be necessary to have multiple hotwells to control the system pressures.

4.2 Gen Sets – Heat Recovery

Heat recovery refers to the capture and utilization of heat energy which is normally wasted. This process, increasingly common today, improves total system efficiency and return on investment.

Reciprocating engines convert about 30-42% of their input fuel energy into mechanical power. Another 20-40% is rejected to the jacket water, 30-40% to exhaust, and 5-7% is radiated to the environment. The heat rejected by the jacket water can be totally recovered and 50-70% of the exhaust energy is economically recoverable. Total heat recovery results in approximately 80% efficiency.

Heat recovery design best suited for any installation depends on many considerations, both technical and economic. The chief function of any design is to cool the engine. The engine must be cooled even when heat demand is low, but power is still required.

There are two heat recovery methods: standard temperature and high temperature. Standard temperature heat recovery systems recover heat from coolant at up to 99°C (210°F) outlet temperature. High temperature heat recovery systems recover heat from coolant at up to 127°C (260°F) outlet temperature. High temperature systems are further divided into solid water, water and steam, and ebullient steam systems.

4.2.1 Heat Balance

The typical heat balance for a Cat engine is shown in Figure 4.3. Heat rejection values for the following components are provided for all engines in the Technical Data Manual or Specification Sheets.

- Jacket Water Heat Rejection
- Oil Cooler Heat Rejection
- Aftercooler Heat Rejection
- Exhaust Heat Rejection
- Exhaust Heat Recoverable

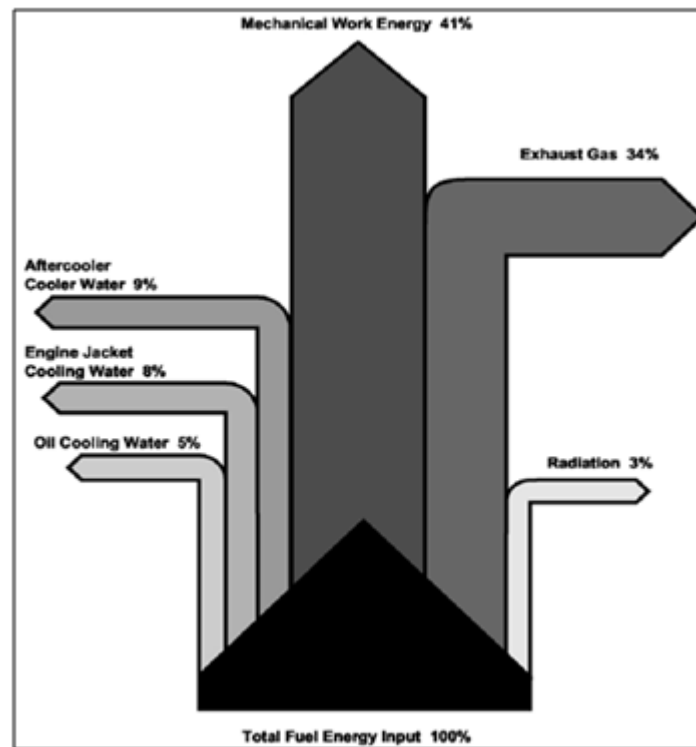

Figure 4.3 — Heat paths in an internal combustion engine.

4.2.2 Heat Balance Calculation

Typical heat balance calculations are illustrated in the following example. The values used in the example are for illustration purposes and should not be used for design. Refer to the published heat rejection data for the specific engine for design calculations.

HEAT BALANCE EXAMPLE

Using a G3612 Combined Heat and Power (CHP) Engine with 11:1 compression ratio rated at 2990 kW Prime Power at 1000 rpm, with the CHP cooling system, as an example:

Engine Output	2990 kW (4010 bhp)	(At 100% load conditions)
Generator Output	2875 kW	(At 96.2% Generator Efficiency)

Heat Rejection Available (from Specification Sheet):	kW	(Btu/min)
a) Engine Jacket (cylinder block) water at 99°C (210°F)	534	(30,321)
b) Oil Cooler (std. shell & tube, 3 coolers)	365	(20,725)
c) Aftercooler (single stage)	652	(37,021)
Total Heat Rejected to the cooling system	1551	(88,066)

Fuel input can be taken from the specification sheet or calculated as shown below,
Total Fuel Input = $\frac{\text{BSFC} \times \text{bkW}}{3.6}$ in kW or = $\frac{\text{BSFC} \times \text{bhp}}{60}$ in Btu/min
 = $\frac{8.66 \times 2990}{3.6} = 7192$ kW (409,009 Btu/min)

Recoverable Heat rejection can be taken from the Specification sheets or calculated.
 Total Exhaust flow from Specification Sheet = 20892 KG/hr (45.962 lb/hr)
 Exhaust Stack Temperature = 359°C (678°F)

Recoverable Exhaust Heat Rejection at 120°C (248°F)*
 = Specific Heat of Exhaust Gas × Total Exhaust Flow × ΔT kW (Btu/min)
 = 1.107 KJ/KG.°C × (20892/3600) KG/sec × (359 – 120)°C **1554 (88,376)**
 where Specific Heat of Exhaust Gases, Cp, is given in the *Heat Rejection* section of the *Cooling System* chapter

Total Recoverable Heat Energy = Jacket water heat energy + Oil cooler heat energy
 + Aftercooler heat energy
 + Exhaust heat energy (at 120°C or 248°F)
 = 534 + 365 + 652 + 1554 =
 = **3105 kW (176,581 Btu/min)**

Recoverable Heat in % = 3105 kW/Fuel input kW = (3105/7192) 100 = **43.2%**

Brake Thermal Efficiency, η_b = bkW/Fuel input kW = (2990/7192) 100 = **41.6%**

Total Thermal Efficiency = Brake thermal efficiency + Recoverable Heat energy
 = 41.6 + 43.2
 = **84.8%**

* The values of Recoverable Exhaust Heat Rejection calculated with this formula will vary by ±3% from the specification sheet values due to changes in Cp value with temperature and other conditions.

Figure 4.4 — Heat balance example.

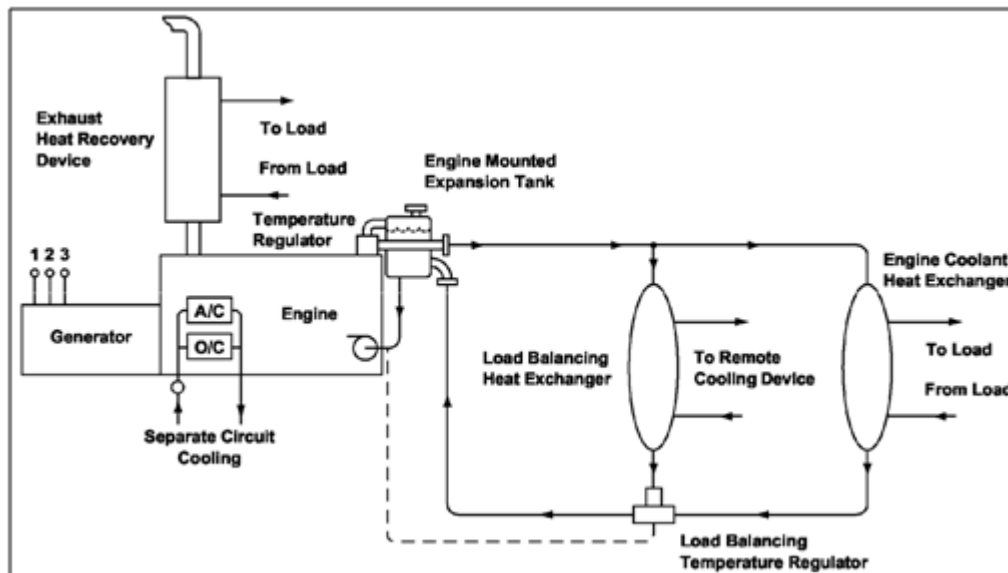

Figure 4.5 — Standard temperature heat recovery system.

4.2.3 Standard Temperature Heat Recovery

Heat recovery of a standard engine may amount to nothing more than utilizing heat transferred from the engine radiator. This air is usually 38-65°C (100-150°F). The recovered heat is quite suitable for preheating boiler combustion air, space heating, or drying grain and lumber. The system cost is minimal and overall efficiency will increase to approximately 60%.

A more versatile method of recovering heat from a standard temperature system uses a heat exchanger to transfer rejected engine heat to a secondary circuit, usually process water. An example system is illustrated in Figure 4.5. There are many advantages inherent with this design. The standard engine jacket water pump, thermostatic configuration, and water bypass line are retained. The engine system is independent from the load process loop, which allows operation with antifreeze and coolant conditioner. This relieves concern for problems associated with using process water to cool the engine.

When normal process load is insufficient to absorb enough heat, load balancing thermostatic valves limit jacket water inlet temperature by directing coolant through a secondary cooling source (load balancing heat exchanger).

Note: The load balancing heat exchanger must be incorporated in the engine loop, not the load loop. The load balancing condenser may be either a heat exchanger or radiator. Heat transfer through the load balancer is usually cyclical. If a radiator is used, it must be designed to withstand thermal shocks developed from cyclic loading.

A second variation on the standard temperature system includes an exhaust heat recovery device in the system in series, parallel, or as a separate water or steam circuit. Consult the manufacturer for design details for the unit in question. Figure 4.6 shows a muffler included in series with the engine system. Note the engine loop is still separate from the load loop. The engine expansion tank may be utilized. Generally, boiler water is used as a medium in the load loop. Boiler water is pumped through the jacket water heat exchanger and exhaust heat recovery device in series where it is heated to the desired temperature. As shown, water flow through the expansion tank provides deaeration.

Application-specific Cooling Systems

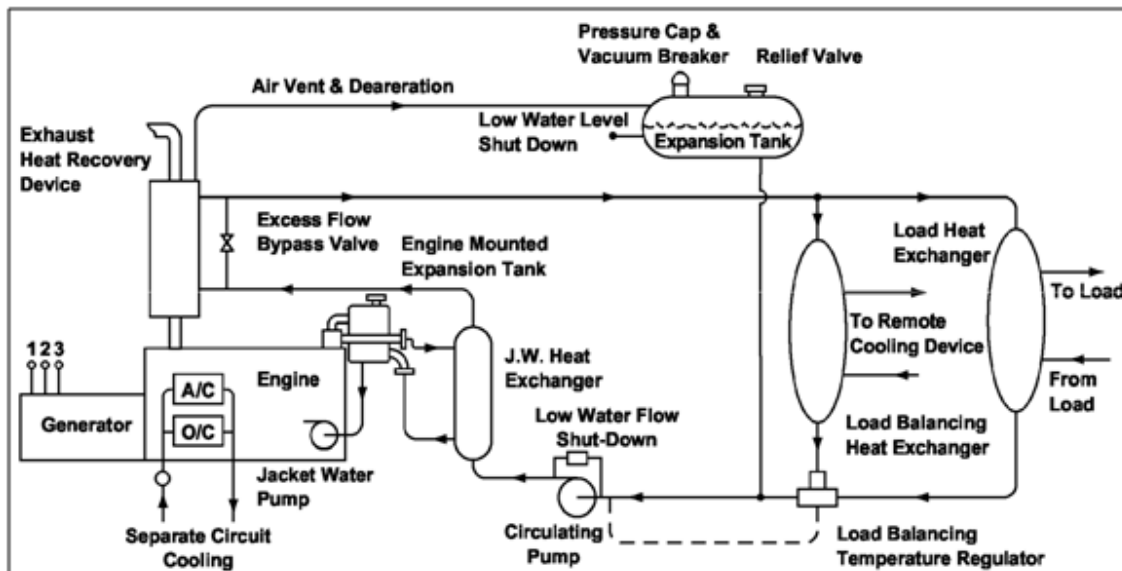

Figure 4.6 — Standard temperature system with muffler in series.

A third variation on the standard temperature system is to incorporate the exhaust heat recovery device into the engine cooling loop (Figure 4.7). To ensure coolant flow through the muffler, the engine thermostats and the bypass line must be removed and an external warm-up thermostat is added. (The added external resistance of the heat recovery device may exceed the allowable resistance available from the engine mounted pump.) An auxiliary circulation pump may be required. The advantages of this system are that the obtainable process water temperature is usually higher and there are fewer components. The disadvantages to this system are the engine cooling system is modified, and the design of the system becomes more critical to successful engine operation.

Caution: Any heat recovery system where the process water circulates in the engine is not recommended.

Experience has shown that, in most cases, the user cannot economically treat the quantity of process water to the level required to avoid maintenance problems with the engine.

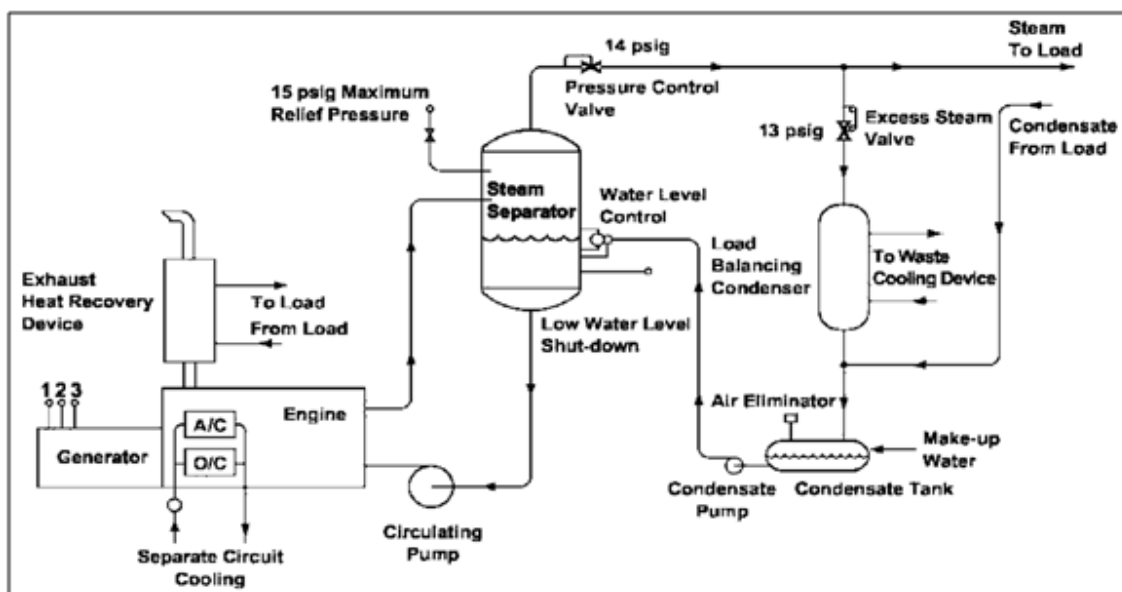

Figure 4.7 — Standard temperature system with exhaust heat recovery.

4.2.4 Critical Design Criteria for Standard Temperature Heat Recovery

The purpose of the following discussion is to call attention to certain basic criteria necessary for proper operation of a heat recovery system. In no way should this be considered an all-inclusive list. Contact a consulting engineer for specific requirements.

- The system must provide adequate coolant flow through the engine so the engine coolant temperature differential (outlet minus inlet) does not exceed 11.1°C (20°F).
- The expansion tank must be the highest point in both the engine and load loop cooling systems. The pressure cap on the expansion tank should be rated for a pressure higher than the inlet pressure requirements of the jacket water pump.
- Use only coolant or treated water in the engine cooling circuit.
- Incorporate deaeration circuit and air vents to eliminate air traps and locks.
- A load balancing thermostatic valve must be used to direct coolant through a secondary cooling source to limit jacket water inlet temperature.
- Coolant must continually flow through the exhaust heat recovery device when the engine operating to avoid thermal shock on hot muffler surfaces. This may be accomplished using a low water flow shutdown device.

After engine shutdown, the coolant must continue to flow through the engine until the coolant temperature falls below 94°C (194°F) to prevent steam pockets from forming inside the engine.

- If the engine thermostats are removed, an external warm-up thermostat is required.
- To keep external head within allowable limits for the engine-mounted pump, locate the heat recovery mufflers and heat exchangers as near the engine as possible. While static head on the jacket water pump is limited to 172 kPa (25 psi), static head greater than 35 kPa (5 psi) requires the expansion tank to be vented to air, i.e., no pressure cap.

4.2.5 High Temperature Heat Recovery Circuits

To ensure proper cooling in all types of high temperature systems, the engine oil cooler and aftercooler require a cooling water circuit separate from the engine jacket water. A thermostat in the oil system bypasses the oil cooler to control lubricating oil minimum temperatures and prevent overcooling. If the coolant in the oil cooler circuit can be below 10°C (50°F), an external control valve is recommended to allow the oil to reach operating temperature, prevent oil gelling, and ensure oil flow through the oil cooler.

4.2.6 Expansion Tanks Used in Heat Recovery Circuits

Full-flow expansion tanks will require greater volume to perform the deaeration function. Engines using high temperature cooling will need a volume larger than the normal 15% to absorb the after-boil that may occur on a hot shutdown (See section on *High Temperature Solid Water System*). Closed accumulator-type tanks are not recommended since they cannot be designed to actively deaerate the coolant.

4.2.7 High Temperature Solid Water System

This system functions similar to a standard temperature water system except elevated jacket water temperatures 99-127°C (210-260°F) are used. The standard thermostat and bypass are removed and replaced by an external control. A pressure cap or static head must be provided in the engine coolant circuit to assure a pressure of 27.6-48.3 kPa (4-7 psig) above the pressure at which steam forms. (See Pressure Control).

The source of this pressure may be a static head imposed by an elevated expansion tank or controlled air pressure in the expansion tank. For 127°C (260°F) water, the pressure at the engine should be approximately 172 kPa (25 psig). Maximum system pressure allowed on the engine water jacket is 276 kPa (40 psig). This is measured by taking the total of circulating differential pressure, system pressure, and static resistance on the system. The standard jacket water pump is removed and must be replaced by one with high temperature and pressure capabilities.

4.2.8 Critical Design Criteria for High Temperature Solid Water

High temperature solid water systems include the same basic requirements as a standard temperature system, but the following points must also be considered.

- A high temperature system requires a pressure control valve for the engine coolant circuit. Water pumps must be suitable for use with elevated temperatures and pressures.
- The engine oil cooler requires a cooling circuit separate from the engine jacket water.
- The load balancing heat exchanger must be incorporated in the engine loop, not the load loop. The load balancing condenser may be either a heat exchanger or radiator. Heat transfer through the load balancer is usually cyclical. Thus, if a radiator is used, it must be designed to withstand thermal shocks developed from cyclic loading.
- For multiple units that share a single steam separator, all circulating pumps must run when any one engine operates. This practice prevents a severe thermal shock if a unit is started later.
- High jacket water temperatures will result in after-boil if there is a hot shutdown. Add an additional 10% of system volume to the normal expansion tank sizing guidelines to provide expansion volume (25% total for high temperature solid water systems).
- When an external water pump is used the engine must be protected from the low flow condition that can occur if the pump fails or is shut off. A differential pressure measurement across the engine's water jacket can be used to trigger this low coolant flow shutdown. The system should be designed such that the external pump is operating any time the engine is running, and the pump should continue to operate after the engine shuts down to help the cool-down process. Five minutes of additional operation is recommended.

4.2.9 High Temperature Water-Steam System

The high temperature water-steam system provides solid water to cool the engine, but then flashes it to steam to be used for loads requiring low-pressure steam, 96 kPa (14 psig). A circulation pump forces water through the cylinder block to the steam separator. In the steam separator, some of the water flashes to steam and the water returns to the engine.

The pressures shown in Figure 4.8 are representative values. The relief valve pressure 103 kPa (15 psig) is set by boiler codes qualifying low-pressure steam. Pressure in the separator is controlled by the pressure control valve. When the pressure builds to 96 kPa (14 psig), the control valve will allow steam to flow. The actual steam pressure in the load line is a function of load requirements. If the load is not consuming steam, the pressure in the steam line will increase. Once pressure reaches 90 kPa (13 psig), the excess steam valve will open to transfer engine heat to the waste cooling device (load balancing condenser). The excess steam valve must be located downstream from the pressure control valve to function properly.

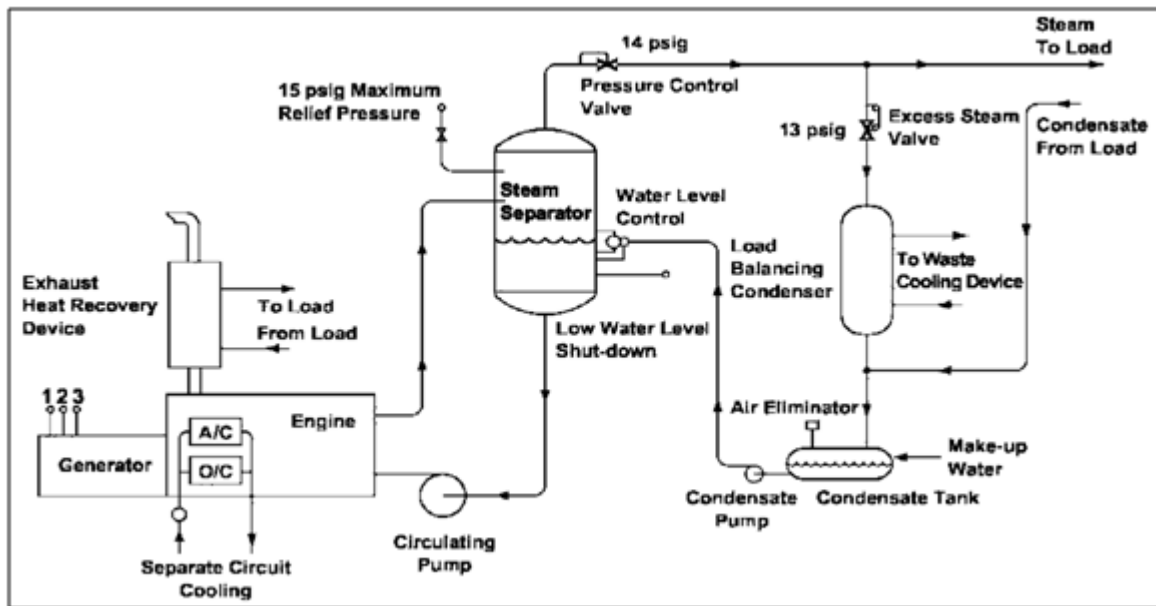

Figure 4.8 — High temperature water-steam system.

4.2.10 Critical Design Criteria for High Temperature Water-Steam

High temperature water-steam systems include the same basic requirements as a standard temperature system and a high temperature solid water system, but there are also the following additional points which are important to consider:

- There are no elevation or static resistance requirements for the steam separator other than what suction head is required for the circulation pump. Thus, this system may be used in locations with limited overhead clearance.
- The maximum temperature at the engine outlet must not exceed 130°C (266°F). Inlet pressure to the pump must be maintained within limits to prevent cavitation at the high temperatures.
- A pressure switch is required at the jacket water inlet to the engine in order to monitor absolute pressure.
- A low water flow shutdown device is required on high temperature cooling engines. This is accomplished by using a differential pressure gauge across the engine water jacket. When the water flow rate slows or stops, the lack of a pressure drop across the engine block will shut down the engine. Since an electric motor driven pump is used, it is important to ensure the pump is operating while the engine is running. The pump should continue running approximately five minutes after the engine is stopped to cool the engine.
- Use only treated water in the cooling circuit. Continuous water chemistry monitoring with automatic boiler blow-down devices are recommended.
- A low water level shutdown on the steam separator device is required. A low water level prealarm is also recommended. Low water level could cause engine overheating and serious damage.
- The excess steam valve cannot be in the steam separator and must be downstream of the pressure control valve.
- A warm-up thermostat is not required since the pressure control valve does not allow any heat (steam) to exit the system until the engine has warmed up and the separator has reached system pressure.

4.3 Water Quality and Treatment for Heat Recovery Cooling Systems

4.3.1 Standard Cooling Systems

The coolant recommendations outlined previously for typical diesel and gas engine applications apply here.

4.3.2 High Temperature Cooling Systems

The engine cooling water in a low pressure steam or high temperature water system can be circulated within the engine water jacket at temperatures above 100°C (212°F). As a result, there is a potential for steam to form in both of these applications. Since several localized areas of the engine jacket water system can have very high heat flux rates and narrow water flow passages, the engine water chemistry will have the same requirements as a close tolerance steam boiler.

Note: The coolant specifications in this guide and in the Caterpillar operator's manual have been written for ethylene glycol systems with temperatures less than 100°C (210°F). This is not applicable for low-pressure steam and high temperature heat recovery systems.

Minerals in the water can precipitate during the heating process and form deposits within the cooling system of the engine. These deposits can restrict the heat transfer and water circulation, resulting in engine failure. To prevent these deposits from forming in the cooling system, the following engine jacket water (boiler water) quality guidelines are recommended.

4.3.3 Make-up Water

Make-up water is added to a low pressure steam system to replace steam and blow down losses. It should not exceed the following maximum concentrations:

- Iron: 0.1 ppm
- Copper: 0.05 ppm
- Total Hardness: 0.3 ppm as CaCO₃

The make-up water can be treated to reduce or remove the impurities from the water. In general, the water is treated when one or more of the feed water impurities are too high to be tolerated by the system. There are many types of water treatment. Softening, evaporation, deaeration, and ion exchange are typical methods used to treat make-up water for a particular system.

4.3.4 Feed Water

Feed water is a mixture of returning condensate and make-up water that enters the engine jacket water loop to replace steam that has left the loop. Water treatment chemicals that are added to the system are usually mixed with the feed water as it enters the engine jacket water system.

4.3.5 Engine Jacket Water

Engine jacket water (boiler water) is a mixture of feed water and resident water. It is the water circulated within the water jacket of the engine to cool the engine and recover heat. Engine jacket water should not exceed the following maximum concentrations:

- Silica concentration: 150 ppm as SiO₂
- Total alkalinity: 700 ppm as calcium CaCO₃
- Specific conductance: 3500 micro mho per cm
- Total suspended solids: 10 ppm

These stringent guidelines are based on established limits of the American Boiler Manufacturer's Association (ABMA) and recommendations of the ASME Research Committee on Water in Thermal Power Systems.

Application-specific Cooling Systems

In addition to the above chemistry, Caterpillar recommends the engine jacket water (boiler water) be treated with chemicals:

- An oxygen scavenger to remove oxygen from the feed water with sufficient reserve in the engine jacket water (boiler water) to remove all oxygen from the water.
- Maintain 200 to 400 ppm as CaCO₃ equivalent of hydroxide alkalinity in the engine jacket water (boiler water). The reserve alkalinity prevents corrosion and causes precipitation of iron and silica in a form that can be removed by blow-down.
- A blend of dispersants to adequately condition and suspend the precipitated solids in the water. The dispersants keep the solids suspended until they are removed during blow-down.
- Appropriate treatment of the steam to provide condensate returning to the engine that meets the engine jacket water (boiler water) specifications.

4.3.6 Total Dissolved and Suspended Solids

Depending on the make-up water source and quality of treatment, the feed water will contain some dissolved and suspended solids. On a low pressure steam system, the steam will leave the engine; however, the minerals and chemicals will remain. This results in a concentrating of the Total Dissolved Solids (TDS).

Engine water jacket scale forms when the concentration of solids reaches a critical point. This depends on the type of contaminants in the feed water, engine operating temperature, and other factors.

4.3.7 Measurement of TDS and Control

TDS can be measured by parts per million, ppm (grains/gal), or by conductivity (micro mhos/cm). The Caterpillar level for TDS is given in micro mhos/cm because conductivity is easier to measure with commercial continuous monitoring equipment or hand-held equipment. There is a direct relationship between ppm and conductance, 2680 ppm = 3500 micro mhos/cm. To avoid exceeding the maximum allowable conductivity, it is necessary to drain off some of the engine jacket water (boiler water) periodically. This is referred to as boiler blow-down. As this occurs, new feed water is added to dilute the water in the engine water jacket, thereby reducing its conductivity.

Historically, operators have performed blow-down manually by periodically opening a valve to drain the steam separator. This may be done once per hour, once per shift, or some other interval, depending on the circumstances.

Because blow-down is only performed periodically, significant dilution is needed to ensure that the engine jacket water (boiler water) conductivity does not exceed the maximum before the operator returns to blow-down the engine again. Note that the conductivity can exceed targeted maximum or even absolute maximum if the operator does not blow-down the boiler at the appointed time, or if the engine steaming rate increases between blow-down operations. If the absolute maximum is exceeded, scaling will occur. Because small amounts of scale wastes energy and can lead to engine damage, it is very important to stay below the absolute maximum.

Conversely, the steam production rate may decrease, and as a result, the operator would blow-down the engine sooner than necessary. Therefore, Caterpillar recommends continuous monitoring of TDS and automatic blow-down controls. Conductivity runs high for ELC — carboxylated type coolants (as compared to traditional coolant inhibitors), usually 4000 micro mhos/cm despite low dissolved solids. A less common method of monitoring TDS is to measure chlorides in both the engine jacket water and the make-up water by a titration process. Since chlorides are not reduced by chemical treatment, the operator can determine the number of concentrations that have occurred in the engine jacket water by comparing the ratio of the two values. Based on known values of the make-up water, the operator can calculate the acceptable number of concentrations that can occur before blow-down is required.

4.3.8 Alkalinity

Alkalinity is required in high temperature water and a low pressure steam system to prevent corrosion. Alkalinity holds silica in solution and causes iron to precipitate in a form removable by blow-down. Too much alkalinity can result in a high pH and cause caustic cracking and caustic attack to external engine compartments.

4.3.9 Total Alkalinity

Total alkalinity is usually measured on site by a titration with methyl orange and is frequently referred to as “M” alkalinity. Many coolant analysis companies refer to the pH of coolant water as its alkalinity. Because of the wide variation in local make-up water and commercial treatments, there is no direct correlation between total alkalinity and pH. Generally, in high temperature water and low pressure steam systems, the pH will be in a range of 10.0 to 11.5 pH.

4.3.10 Reserve of Hydroxide Alkalinity

To prevent corrosion and scale deposits, a reserve of hydroxide (OH) alkalinity is required. The OH alkalinity is not easily measured in the field, but can be calculated. A “P” alkalinity is measured with phenolphthalein indicator in a sulfuric acid titration. Once “P” value is determined, the following formula is used to calculate “OH” alkalinity.

- “OH” Alkalinity = 2 x “P” Alkalinity – “M” Alkalinity

Low pressure steam engines will have special requirements if the unit does not run continuously. Any low pressure steam engine that is shut down frequently can be prone to deposits even with a good water treatment program. Once the engine is shut down, the dispersants in the feed water can no longer keep the solids in suspension. They will settle to the low parts of the system, which is usually the engine. These solids will collect and harden to form scales and can result in engine failure. For turbocharged and aftercooled (TA) ebullient and all ebullient engines that do not run continuously, a circulating pump of 100 kg water/kg of steam (100 lb water/lb of steam) capacity is recommended. The circulating pump should be operated even while the engine is shut down to keep the solids in suspension. High output TA engines can benefit from the addition of a circulating pump to prevent hot spots and reduce deposits.

The above water chemistry limits are stringent, but not excessive when considering that deposits formed within the engine are cumulative. Cogeneration and heat recovery equipment is intended to last 20 years or longer. To maintain the performance and value of equipment, it is important to eliminate scale deposits within the engine. Once a deposit is formed, it is very difficult and may be economically impractical to remove.

Note: Scale formation is cumulative. The most successful method of preventing scale problems is to avoid the conditions that allow scale to form.

These guidelines are based on established limits of the American Boiler Manufacturer’s Association (ABMA) and suggested guidelines by the ASME Research Committee on Water in Thermal Power Systems.

Operators who adhere to these guidelines are likely to have years of deposit-free and scale-free performance from their Cat engines. Since water chemistry and water treatment are very regional items and vary considerably around the world, the engine owner has the ultimate responsibility for the engine cooling water treatment.

5.0 Marine Diesel

5.1 Keel Coolers

A keel cooler is an outboard heat exchanger which is either attached to, or built as part of, the submerged part of a ship's hull. They are typically used in marine applications operating on inland waterways and rivers, where there is potential for encountering muddy or silt-laden cooling water.

The heated water from the engine is circulated through the keel cooler by an engine-driven water pump.

Figure 5.1, Figure 5.2, and Figure 5.3 represent three typical keel cooler system configurations.

- Jacket Water Aftercooled with Keel Cooler
- Separate Circuit Aftercooled with Keel Coolers
- Separate Circuit Aftercooled with Keel Coolers (with Aftercooler Keel Cooler Bypass)

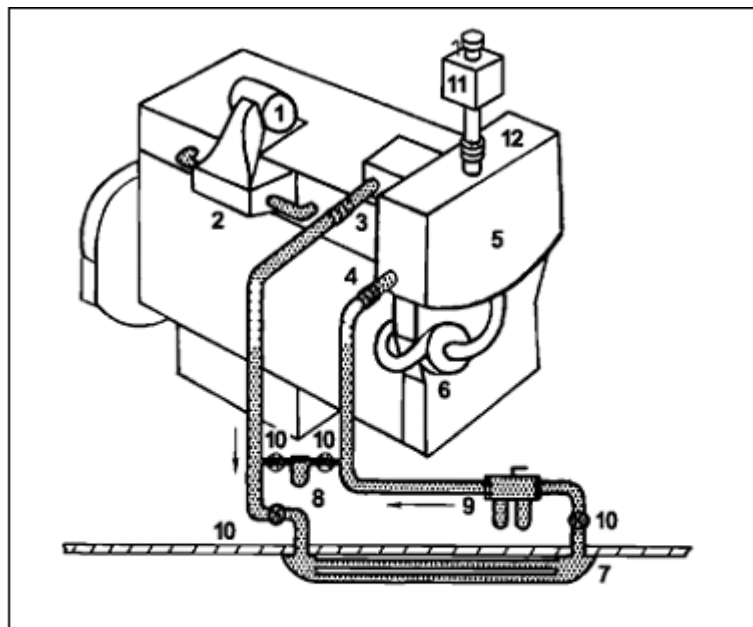

- | | |
|-------------------------------------|------------------------------|
| 1. Turbocharger | 7. Keel Cooler |
| 2. Aftercooler, Jacket Water Cooled | 8. Bypass Filter |
| 3. Jacket Water Outlet Connection | 9. Duplex Full-Flow Strainer |
| 4. Jacket Water Inlet Connection | 10. Shut-Off Valve |
| 5. Expansion Tank | 11. Auxiliary Expansion Tank |
| 6. Jacket Water Pump | 12. Flexible Connection |

Figure 5.1 — Jacket water aftercooled – keel cooler.

5.2 Jacket Water Aftercooled with Keel Cooler

Jacket water aftercooling uses engine jacket water in the tube side of the aftercooler and results in inlet manifold temperatures lower than those obtained in non-aftercooled turbocharged engines. The lower inlet manifold air temperature allows a jacket water aftercooled engine to achieve a rating higher than either a naturally aspirated or a turbocharged-only engine. Jacket water aftercooled circuits are completely installed at the factory.

Jacket water aftercooling, when feasible for a particular application, represents the simplest cooling system possible. When coupled with the use of a keel cooler, it becomes even simpler, with only one cooling circuit required per engine.

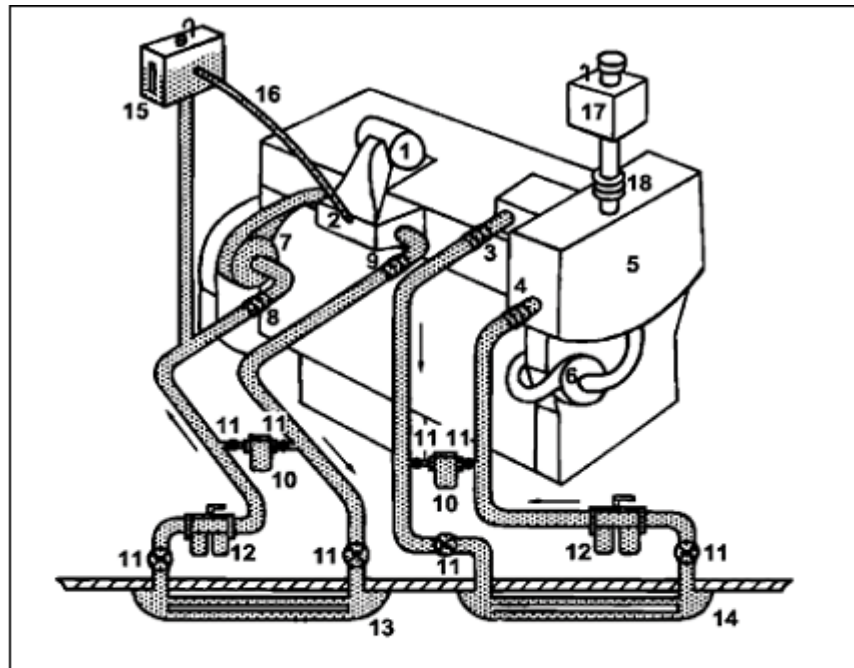

- | | |
|---|--|
| 1. Turbocharger | 10. Bypass Filter |
| 2. Aftercooler, Keel Cooled | 11. Shut-Off Valve |
| 3. Jacket Water Outlet Connection | 12. Duplex Full-Flow Strainer |
| 4. Jacket Water Inlet Connection | 13. Keel Cooler for Aftercooler |
| 5. Expansion Tank | 14. Keel Cooler for Jacket Water |
| 6. Jacket Water Pump | 15. Expansion Tank for Aftercooler Circuit |
| 7. Auxiliary Fresh Water Pump | 16. Vent Line for Aftercooler Circuit |
| 8. Auxiliary Fresh Water Inlet Connection | 17. Auxiliary Expansion Tank |
| 9. Aftercooler Outlet Connection | 18. Flexible Connection |

Figure 5.2 — Separate circuit aftercooled – keel cooler.

5.3 Separate Circuit Aftercooled with Keel Coolers

The use of keel coolers in the aftercooler circuit allows a low temperature, fresh water, closed circulating system to be used. All closed fresh water aftercooler circuits require the installation of an expansion tank. Refer to the section of auxiliary expansion tanks. The use of an inlet manifold air temperature gauge, or alarm, can provide guidance for required cleaning of the system in order to maintain the desired engine performance, and is strongly recommended.

Caution must be used when using the aftercooler keel cooler water circuit to cool an auxiliary piece of equipment, such as a marine transmission. The auxiliary equipment cooler should be connected to the water circuit after it leaves the engine aftercooler to avoid adding any heat to the water before it enters the aftercooler. The additional resistance of the auxiliary equipment cooling circuit must be held to a minimum to avoid reducing the flow of water to the aftercooler.

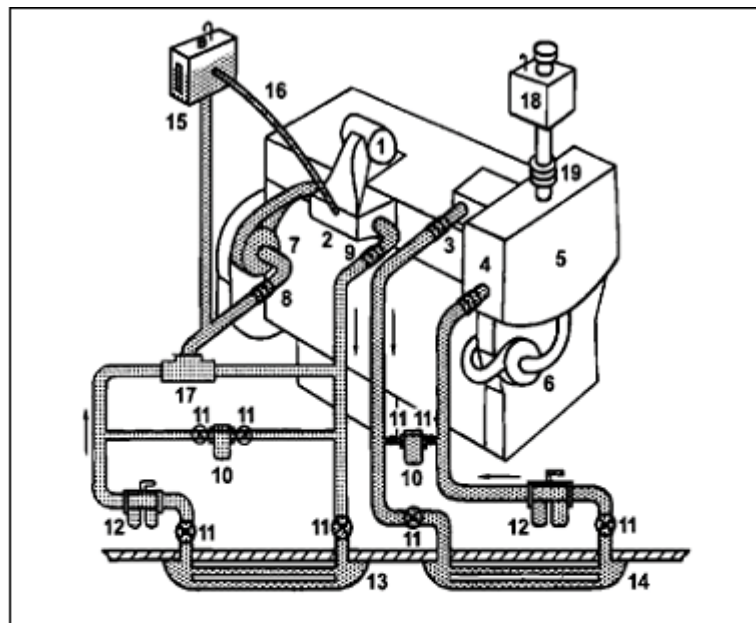

- | | | |
|-----------------------------------|---|---|
| 1. Turbocharger | 8. Auxiliary Fresh Water Inlet Connection | 15. Expansion Tank for Aftercooler Circuit |
| 2. Aftercooler, Keel Cooled | 9. Aftercooler Outlet Connection | 16. Vent Line for Aftercooler Circuit |
| 3. Jacket Water Outlet Connection | 10. Bypass Filter | 17. Bypass Valve, Thermostatically Controlled |
| 4. Jacket Water Inlet Connection | 11. Shut-Off Valve | 18. Auxiliary Expansion Tank |
| 5. Expansion Tank | 12. Duplex Full-Flow Strainer | 19. Flexible Connection |
| 6. Jacket Water Pump | 13. Keel Cooler for Aftercooler | |
| 7. Auxiliary Fresh Water Pump | 14. Keel Cooler for Jacket Water | |

Figure 5.3 — Separate circuit aftercooled – aftercooler keel cooler bypass.

5.4 Separate Circuit Aftercooled with Keel Coolers and Aftercooler Keel Cooler Bypass

The separate circuit aftercooler cooling system must be designed with sufficient capacity for the hottest water and the higher ambient air conditions for operation in climates where both air and seawater temperatures run to extremes. This results in a cooler with excess capacity in cold seawater and warm air conditions. This can result in condensation in the engine's intake system, especially during prolonged light engine load.

To minimize condensation during light engine load in separate circuit aftercooled systems, it is desirable to maintain the inlet manifold temperature between 38°C and 52°C (100°F and 125°F). This may be achieved by recirculating the aftercooler cooling water back to the auxiliary water pump inlet until the desired temperature is reached. Cool water should then be mixed with the recirculated water to maintain the temperature. The temperature of the water to the aftercooler can be controlled by using a thermostatically controlled three-way valve.

5.5 Fabricated Keel Coolers

Fabricated keel coolers may be made of pipe, tubing, channel, I-beams, angle, or other available shapes. The choice of materials used is dependent on the waters in which the vessel will operate. These materials must be compatible with materials used in the vessel's hull in order to prevent galvanic corrosion.

5.6 Sizing of Fabricated Keel Coolers

Engine water temperature maximum limits are controlled by size of the keel cooler. Heat transfer rates through any cooler depend mainly on cooling water temperature, cooling water flow, and heat transfer surface area. A cooler may have to operate at its maximum capacity at zero hull speed, as in the case of an auxiliary generating set, operating while the vessel is in port. The minimum area calculated includes a fouling factor. Materials used in cooler construction, condition of waters in which the vessel will operate, and service life expectancy will influence the size selection of a new cooler.

The keel cooler sizing worksheet in Appendix D and the keel cooler area recommendations contained in Figure 5.4, Figure 5.5 and Figure 5.6 apply only to keel coolers made of structural steel (channel, angle, half pipe, etc.) welded to the ship's shell plating. These recommendations take into account the thermal resistance to heat transfer of the steel plate, the internal and external water films, and the internal and external surface corrosion factors. The coefficient of heat transfer of the fresh water film flowing inside the cooler is based upon a flow velocity of 0.9 m/sec (3 ft/sec). The coefficient of heat transfer for the raw water film varies with the velocity of water flow past the cooler due to vessel speed. Surface corrosion factors are based on treated fresh water and polluted river water. Miscellaneous factors become so predominant in the resultant heat transfer rate that the type of material used and thickness of metal become minor considerations.

Normal deterioration of the cooler's inner and outer surfaces in the form of rust, scale, and pitting progressively reduce a keel cooler's effectiveness over a period of years. Protective coatings and marine growths will also reduce the rate of heat transfer. It can take four to five years before deterioration stabilizes in keel coolers. Keel coolers must be designed considerably oversized when new.

Because of the severe deterioration of heat transfer characteristics associated with structural steel coolers, adequate cooler size sometimes becomes impractical. This is particularly true where seawater temperatures are over 30°C (85°F). In these high seawater temperature regions, the use of "packaged" keel coolers, or box coolers, made of corrosion-resistant materials is suggested. These coolers can provide more heat exchange surface area in a given volume on, or within the hull, than the coolers made of structural steel.

5.7 Marine Gear Heat Rejection

Marine gears, or transmissions, whether offered by Caterpillar or provided by a marine gear manufacturer or supplier, will all generate heat. Typical marine gears are 95% to 97% efficient, with the 3% to 5% efficiency loss (or power loss factor) representing the amount of heat being rejected to the marine gear oil.

While the actual marine gear efficiency can be provided by the gear manufacturer based on the specific application, a good rule for cooler sizing is to use 95% efficiency with a 5% power loss factor.

Maximum heat rejection to the marine gear cooling system is equal to the transmitted power from the engine multiplied by the power loss factor.

$$H_{\text{marine gear}} = P_{\text{engine}} \times F_{\text{power loss}}$$

Where:

$H_{\text{marine gear}}$ = Heat rejection of the marine gear oil

P_{engine} = Power generated in the engine and transmitted through the marine gear

$F_{\text{power loss}}$ = A factor relating the heat generated in the marine gear oil to the marine gear efficiency

The following conversion factors are tabulated below.

$$31.63 \times \text{kW} = \text{Btu/min}$$

$$42.41 \times \text{hp} = \text{Btu/min}$$

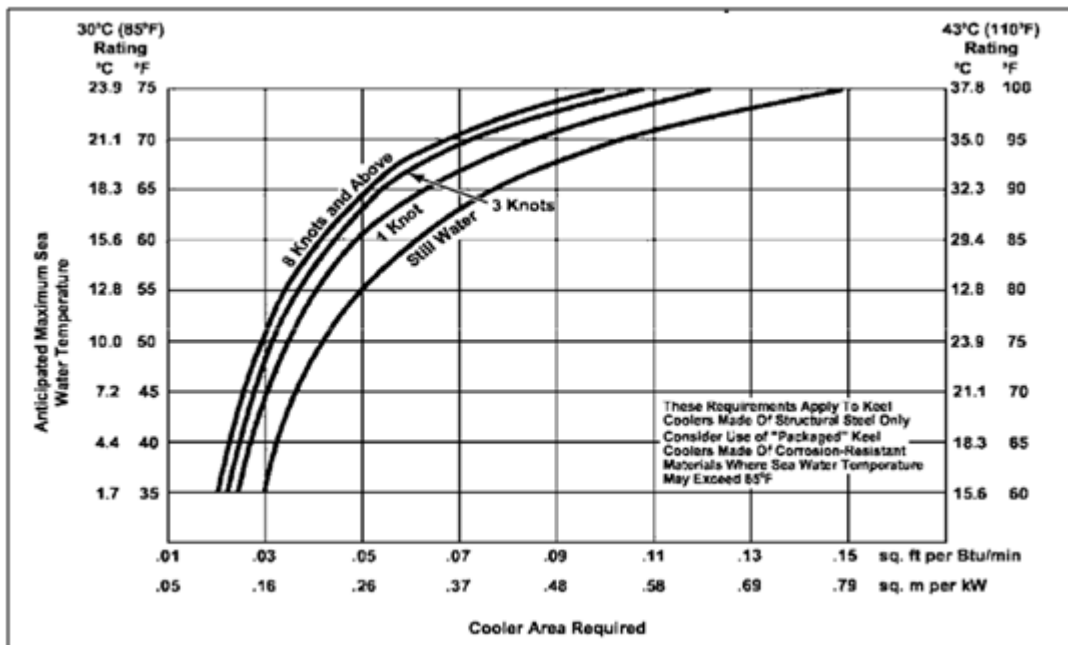

Figure 5.4 — Aftercooler water keel cooler area requirements.

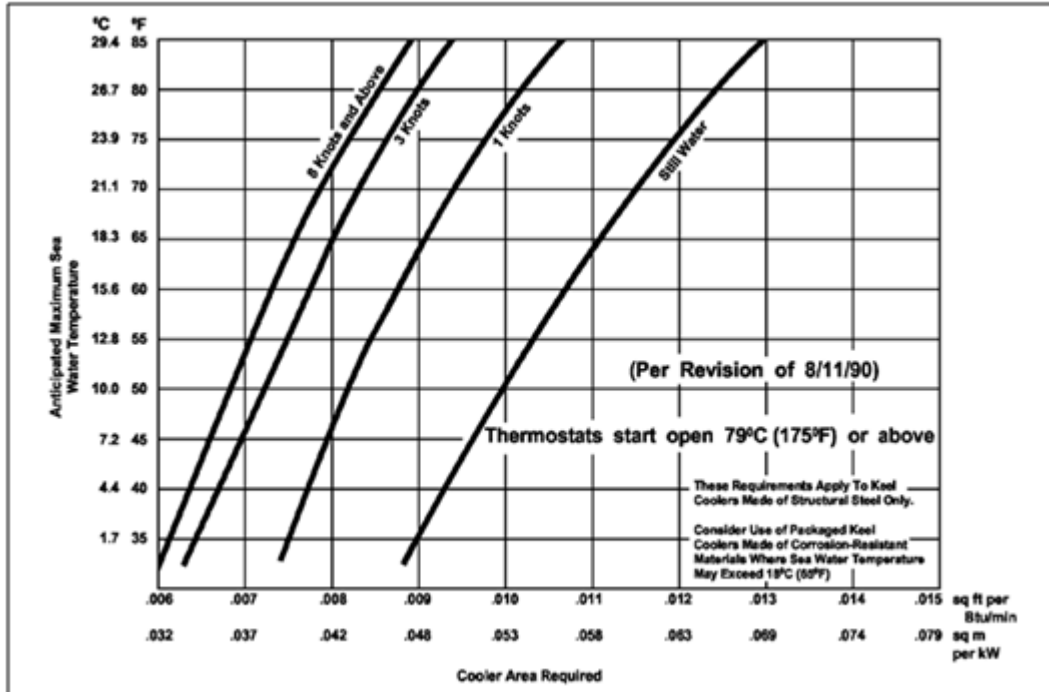

Figure 5.5 — Jacket water keel cooler area requirements.

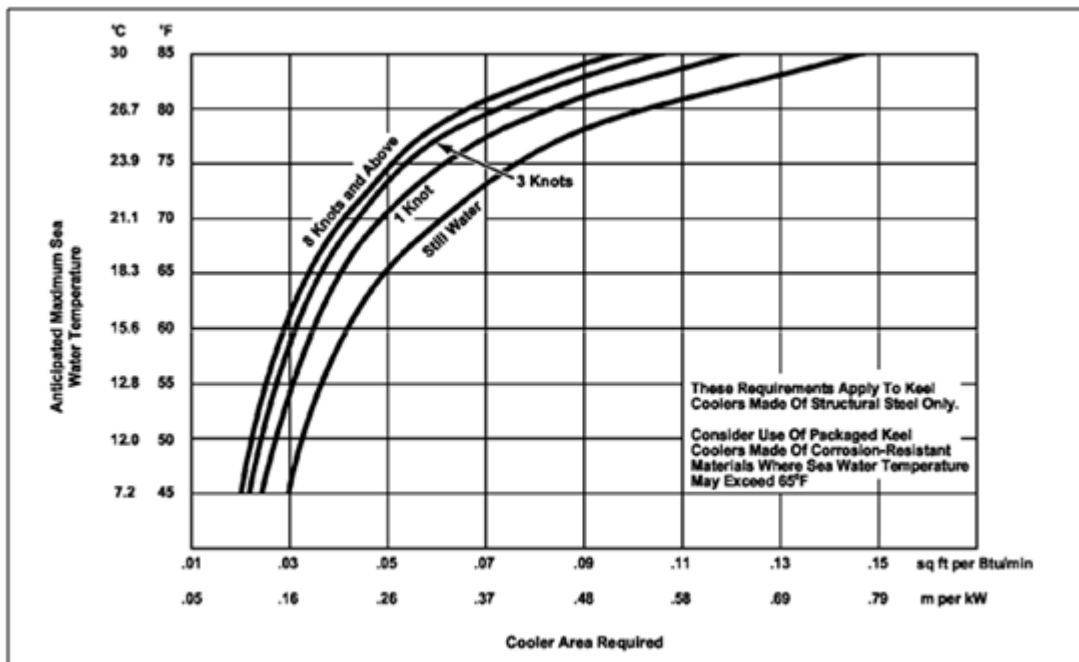

Figure 5.6 — Marine gear keel cooler area requirements
35°C (95°F) maximum water to transmission heat exchanger.

5.8 Design/Installation Considerations

5.8.1 Coolant Velocity Inside the Cooler

If water flow through the keel cooler is too fast, the cooler can be damaged. Water velocity over 2.5 m/sec (8 ft/sec) will erode internal components, particularly near manifold entrances and exits, elbows and other discontinuities in the water flow.

If the water flows through the keel coolers too slowly, cooler efficiency will be reduced. Water velocity less than 0.6 m/sec (2 ft/sec) will allow rust particles, sand, and other particulate matter to settle out of the water and into the cooler. This tends to choke off the flow and degrade the transfer of heat.

Use the following procedure to determine the proper flow pattern through the keel cooler.

- Determine the maximum and minimum expected water flow through the keel cooler. This can be determined from the engine's water pump performance data.
- Subtract the minimum expected water flow from the maximum expected water flow.
- Multiply the resultant difference (between the min and max flow) by 2/3. Add 2/3 the resultant difference from the prior step, as this is the most likely water flow through the keel cooler (This is dependent on the use of good practice in sizing the connecting piping). Use this figure to determine how to distribute the water flow through the keel cooler passages.
- Determine the cross-sectional area of one keel cooler passage. This is best done by consulting the manufacturer or an engineering reference on shapes of structural channel, pipes, angles, and other flow details.
- Use a good conversion factor table to convert the most likely water flow to units of m³/min (ft³/min).
- Use a good conversion factor table to convert the cross-sectional area of one keel cooler passage to units of m² (ft²).
- Divide the most likely water flow by the cross-sectional area of one keel cooler passage.
- The result will be the average velocity through the keel cooler flow passages. If the average velocity through the keel cooler flow passages is greater than 2.5 m/sec (8 ft/sec), arrange the water flow in parallel, so that it passes through two or more of the keel cooler passages per pass through the keel cooler. If the average velocity through the keel cooler flow passages is less than 0.6 m/sec (2 ft/sec), use a keel cooler passage with a smaller cross-section area.

5.8.2 Use of Keel Inserts to Improve Local Flow Velocity

It is economically desirable to use steel channels for keel cooler passages which are large in cross-sectional area. Unfortunately, this design produces water flow that is too slow for effective heat transfer. Keel cooler inserts are used in these coolers to cause localized high water velocity or turbulence within the keel cooler passage.

An effective design for keel cooler inserts is a ladder-like device, inserted into the full length of the keel cooler passages. Typical inserts should have the following design features:

- The inserts must be made of the same metal alloy as the hull and keel cooler to protect against galvanic corrosion.
- The "rails" of this ladder shape should be made of 6 mm (.25 in) diameter rod.
- The "rungs" of this ladder shape should be made from flat bar that has approximately the same shape, but 70% of the cross sectional area of the keel cooler flow passages.
- The flat bar cross pieces must not restrict flow through the keel cooler flow passages, but simply redirect the flow to avoid laminar flow due to too slow an average velocity.

Insert the ladder into the keel cooler flow passages and weld on the end fittings (inlet and outlet manifolds).

5.8.3 Direction of Flow through Keel Coolers

Engine coolant should flow through the keel cooler from the rear of the vessel toward the front of the vessel. This is counter-flow to the seawater and will significantly increase the effectiveness of the heat transfer. This is rarely practical to implement completely since the flow must be divided through the various flow passages in the keel cooler. If the flow is divided through too many passages, the velocity becomes too slow to maintain turbulent flow conditions. This will reduce heat transfer. The best compromise is to manifold the coolant in such a way that the flow, in the largest practical number of flow passages, is from rear to the fore end of the vessel.

5.8.4 Bypass Filters

Welded structural steel keel or skin cooler systems require the installation of strainers between the cooler and the pump inlet. Material, such as weld slag and corrosion products, must be removed from the system to prevent wear and plugging of cooling system components. Use a continuous bypass filter to remove smaller particles and sediment. The element size of the continuous bypass filter should be 20 to 50 microns (0.000787 to 0.000197 inches). Do not exceed 19 L/min (5 gal/min) water flow through the bypass and filter.

5.8.5 Strainers

Full-flow strainers are desirable. The strainer screens should be sized no larger than 1.6 mm (.063 in) mesh for use in closed freshwater circuits. The strainer connections should be no smaller than the recommended line size. The use of a differential pressure gauge across the duplex strainers will indicate the pressure drop, and enables the operator to determine when the strainers need servicing.

The pressure drop across a strainer at the maximum water flow must be considered part of the system's external resistance. Suppliers can help in the proper selection of strainers and furnish the values of pressure drop versus flow rate. The strainer should be selected to impose no more than 1 m (3 ft) water restriction to flow under clean strainer conditions.

5.9 Packaged Keel Coolers

Although the channel type keel cooling system discussed so far provides advantages over seawater cooling by eliminating silt/sand build-up and protecting against corrosion, their bulk size and location can reduce a vessel's capacity and increase its drag. They are also prone to seaweed fouling. A more compact and streamlined keel cooler can be provided with a packaged type keel cooler, as shown in Figure 5.7.

Packaged keel coolers are purchased as prefabricated units and mounted to the outside of a ship's hull. Manufacturers offer keel coolers in many configurations. They are generally made of copper-nickel alloys and are initially toxic to marine growth. This is one of their more important advantages. Another important advantage of packaged keel coolers is their compactness and lightweight when compared to fabricated keel coolers. Some packaged keel coolers are able to cool an engine with less than 20% of the heat transfer surface of an analogous fabricated keel cooler.

5.9.1 Sizing of Packaged Keel Coolers

Manufacturers of packaged keel coolers publish sizing guides which help users determine the proper cooler size for specific conditions. Caterpillar does not offer guidance outside of manufacturers guidelines, other than providing the worksheet in Appendix D for the collection of appropriate keel cooler sizing data. This data can then be used by the keel cooler manufacturer to determine the proper keel cooler.

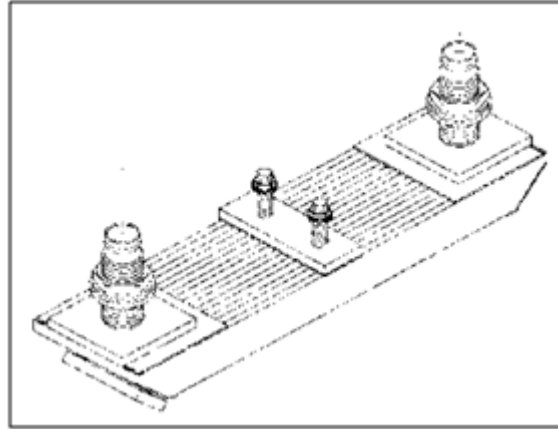

Figure 5.7 — Packaged keel cooler.

5.9.2 Location of Keel Coolers on the Hull

Keel coolers can be mounted almost anywhere on a ship's hull, providing the flexibility to match a cooler's installation to the hull design and operating conditions of most ships. For example; on shallow draft riverboats, the coolers may be mounted on the side of the hull or on the skeg. On towboats, they may be mounted near the propeller in order to take advantage of the slipstream during heavy towing operations. On fast vessels, they are usually recessed alongside the keel.

Mount the keel cooler in a well-protected area on the hull. This is particularly true of packaged keel coolers which are manufactured of lighter gauge material than fabricated keel coolers.

To achieve the greatest possible heat transfer, mount separate keel coolers for the aftercooler low on the hull and forward of other keel coolers. As with jacket water routing, the aftercooler coolant should flow through the keel cooler from the rear of the vessel toward the front of the vessel. This arrangement assures maximum heat transfer with the vessel moving forward or motionless.

Although the area immediately forward of the propeller is a region of high water velocity and high enough on the hull to be protected from grounding damage, one must consider the effects on the keel cooler from the propeller. During backing maneuvers, the propeller will create a sandblasting effect by casting sand and debris toward the cooler.

Additional considerations for keel cooler mounting:

- Seawater must flow over the entire length of the unit.
- The cooler must be parallel to the skeg or keel.
- When mounted on the side of the hull, the cooler must be positioned below the lowest water line to avoid aerated surface water.
- On fast vessels, keel coolers should be located as far aft as possible to avoid aeration.
- Keel coolers should not be located directly above propellers, in any known high vibration area, or near any raw water suction or discharge ports.

5.10 Pumps for Keel Cooler Circuits

Ordinarily, the engine water pump will satisfactorily circulate the engine jacket water through the keel cooler, if the water lines to and from the cooler are relatively short, of adequate size, with minimum bends, and if the keel cooler restriction is low. If the total external flow resistance cannot be held within the jacket water pump's capacity, then the engine-driven pump may need to be replaced with a suitably sized electric motor-driven pump.

5.11 Venting and Piping of Keel Coolers

Locate the cooler and its through-hull connections so the length of water piping will be kept to a minimum and the cooler will be well vented. Extend water piping downward from the engine to the keel cooler without high points.

It is very difficult to purge trapped air from the high points of some keel coolers. The air must be bled off during initial fill or when the system is completely drained. Vent plugs must be designed into the keel coolers where they rise toward the bow and stern and any other high points where air may be trapped.

5.12 Corrosion Inhibitors

A suitable corrosion inhibitor, carefully maintained, will minimize internal corrosive effects. See the section on Cooling System Protection.

5.13 Submerged Pipe Cooling

Submerged pipe cooling is a simple, but yet effective, way of rejecting heat from the engine and can be used if the engine is located near a supply of relatively cool water, preferably 29°C (85°F) or less. In this system, the engine coolant water is pumped through coils (or lengths of pipe) that are submerged in the nearby cool water. Figure 5.8 shows an example of a typical submerged pipe cooling system. A concrete catch basin or tank should be placed in the source of the cooling water. This will help ensure a consistent volume of water around the coils and help keep mud and silt from burying the coils. The pipes must be supported up, and off the bottom of the tank to ensure maximum cooling efficiency.

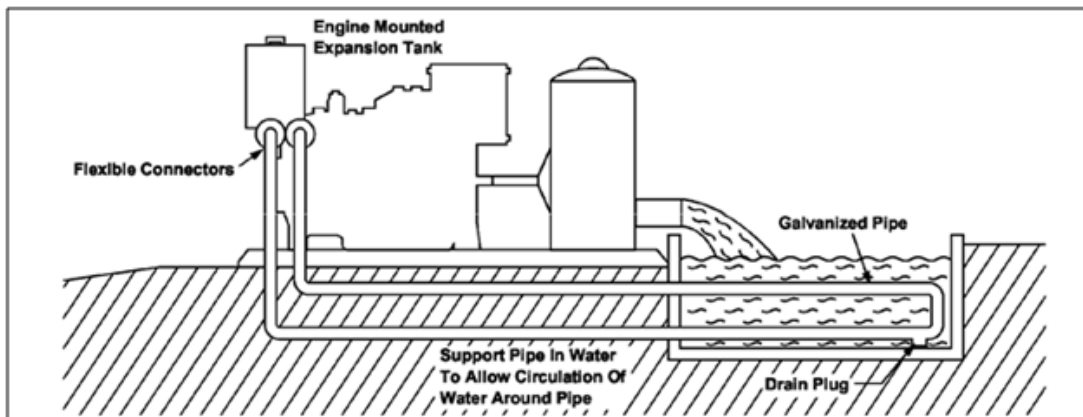

Figure 5.8 — Submerged pipe cooling system.

Engine heat rejection and the temperature of the cooling medium must be carefully considered in determining the correct amount of pipe to use. As a rule-of-thumb, 0.003 m² (0.0353 ft²) of submerged pipe surface area is required for every 1.055 kJ/min (1 Btu/min) of jacket water heat rejection that must be removed. This rule-of-thumb is for raw water temperatures up to 29°C (85°F). A trial and error method can be used if jacket water temperature is too high or too low; by adding or removing pipe as necessary, the engine cooling water temperature can be maximized.

The system should be connected so that jacket water flows from the engine, to the cooling coils, and to the expansion tank, before returning to the water pump inlet.

5.14 Box Coolers

Box coolers represent another type of packaged cooler that is sometimes used in marine applications. As seen in Figure 5.9, box coolers are mounted inside a vessel's sea chest. This location provides excellent protection from mechanical damage, but does negate the benefit that vessel speed through the water provides for keel cooler installations. However, box coolers, like keel coolers, eliminate the need for the raw water system associated with the use of inboard heat exchangers.

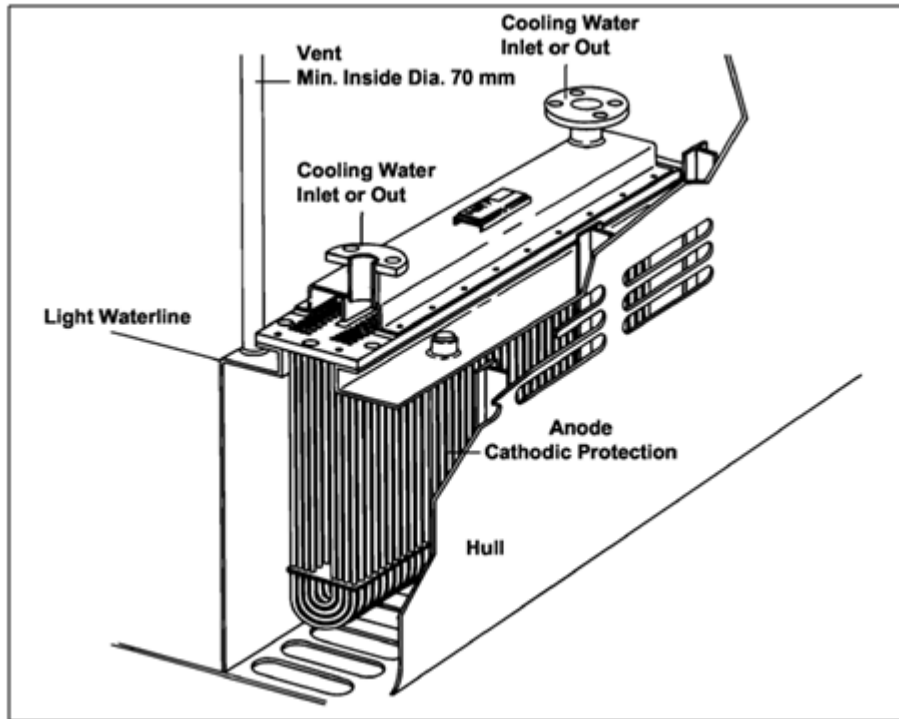

Figure 5.9 — Typical box cooler.

5.15 Seawater Systems

Due to its obvious proximity and excellent heat transfer capabilities, seawater is commonly used as a cooling medium in marine and offshore applications. Seawater cooling systems, similar to other types of cooling systems, have many special design considerations that must be taken into account in order to ensure satisfactory engine operation and service life.

Typical seawater cooling system configurations are represented in Figure 5.10, Figure 5.11, Figure 5.12, and Figure 5.13.

- Jacket Water Aftercooled with Heat Exchanger
- Seawater Aftercooled
- Separate Circuit Aftercooled with Heat Exchangers Separate Circuit
- Aftercooled with Heat Exchangers (with Aftercooler Seawater Recirculation)

5.16 Jacket Water Aftercooled with Heat Exchanger

Heat exchangers can be mounted on the engine or remote from the engine. Engine-mounted heat exchangers require the least amount of pipe fitting since the jacket water connections to the heat exchanger are provided by the factory.

Remote-mounted heat exchangers require connecting the jacket water inlet and outlet at the engine to the shell side of the exchanger. As shown in Figure 5.10, an engine-driven seawater pump is used to circulate the cooling water through the heat exchanger.

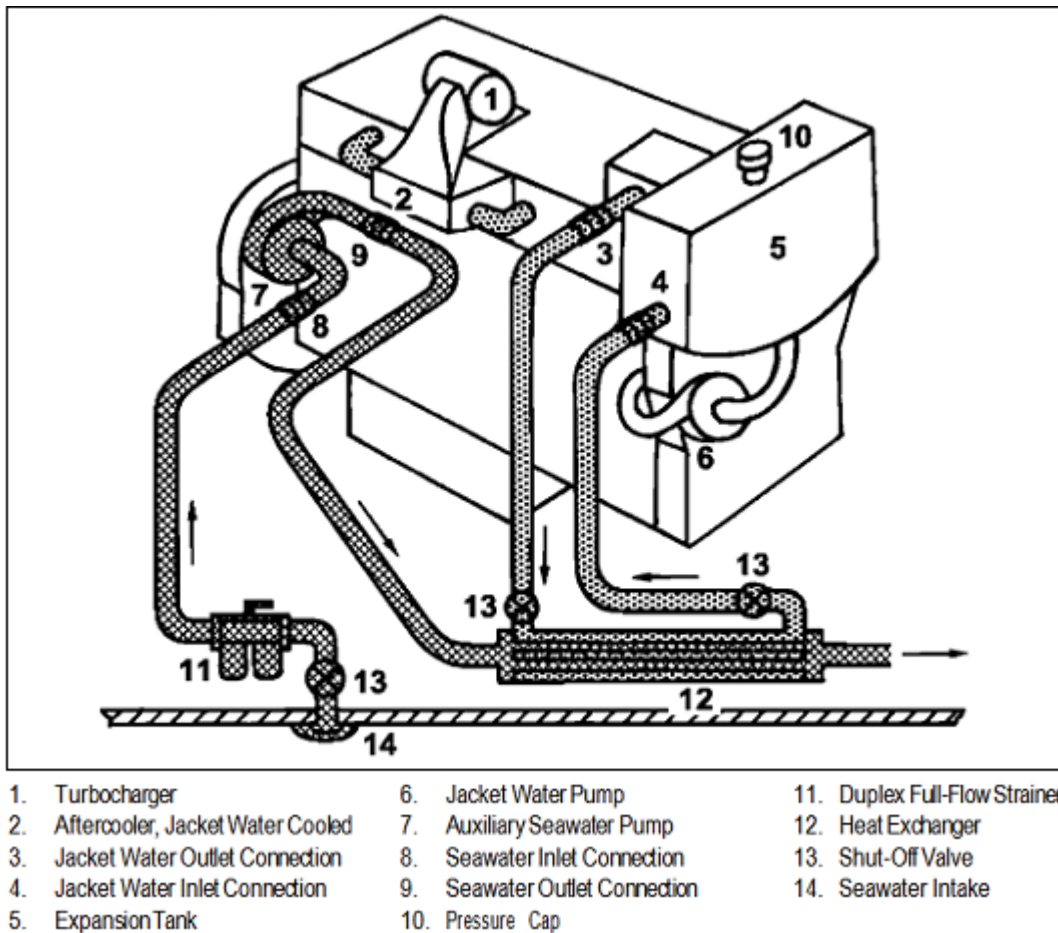
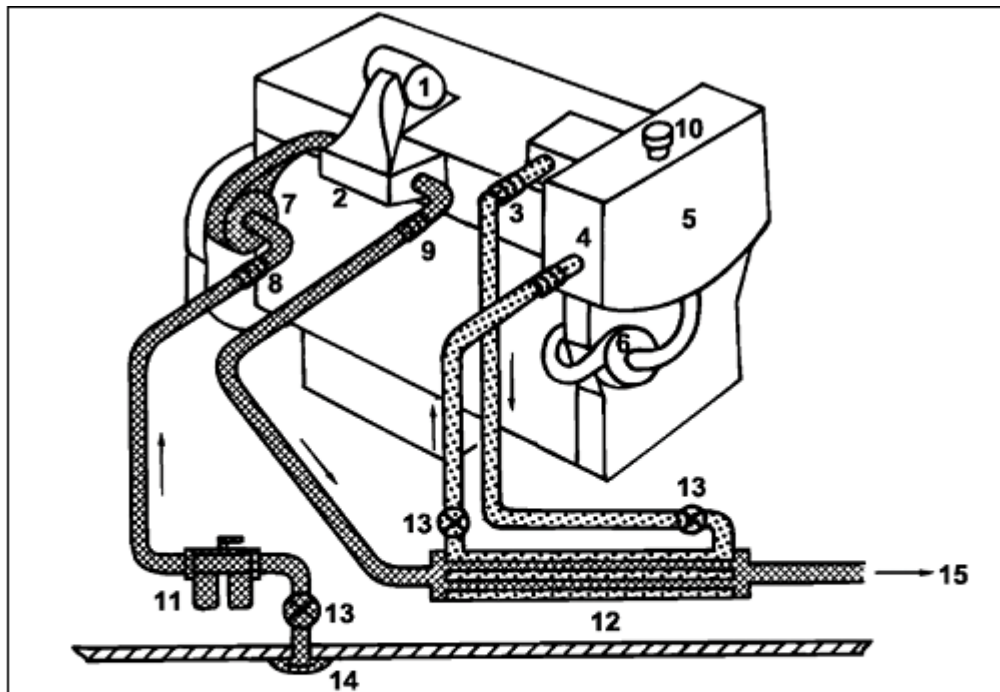

Figure 5.10 — Jacket water aftercooled with heat exchanger.

5.17 Seawater Aftercooled

Engines equipped with seawater aftercoolers use untreated water in the tube side of the aftercooler. Seawater refers not only to salt water but also includes river water, lake water, or any source of untreated water. Use of seawater for aftercooling achieves inlet manifold air temperatures lower than those resulting from jacket water or separate circuit fresh water aftercooling. This lower inlet manifold air temperature permits ratings of seawater aftercooled engines that exceed those of jacket water aftercooled engines.



- | | | |
|--------------------------------|--|------------------------|
| Turbocharger | 7. Auxiliary Seawater Pump | 12. Heat Exchanger |
| Aftercooler, Seawater Cooled | 8. Auxiliary Seawater Inlet Connection | 13. Shut-Off Valve |
| Jacket Water Outlet Connection | 9. Aftercooler Outlet Connection | 14. Seawater Intake |
| Jacket Water Inlet Connection | 10. Pressure Cap | 15. Seawater Discharge |
| Expansion Tank | 11. Duplex Full-Flow Strainer | |
| Jacket Water Pump | | |

Figure 5.11 — Seawater aftercooled system.

5.18 Separate Circuit Aftercooled with Heat Exchangers

A heat exchanger will also provide cooling for fresh aftercooler water if the seawater temperatures are cold enough to provide adequate cooling. The use of an inboard heat exchanger for the aftercooler circuit requires the use of a seawater pump in addition to the freshwater pump used to circulate water through the aftercooler. An expansion tank is also required for the aftercooler circuit.

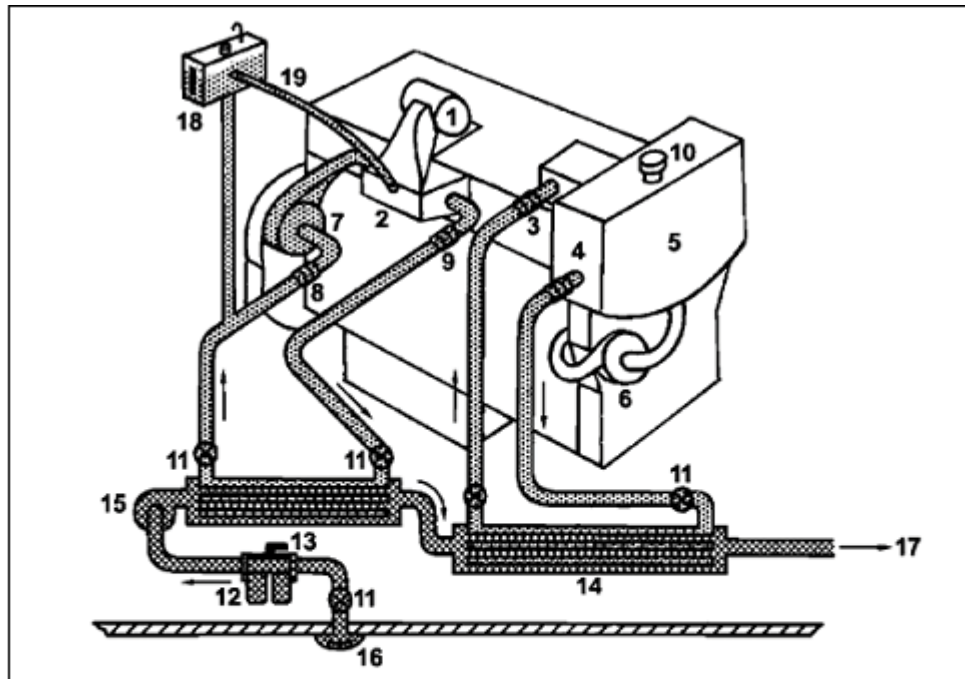

Turbocharger	8. Auxiliary Fresh Water Inlet Connection	15. Customer-Provided Seawater Pump
Aftercooler, Heat Exchanger Cooler	9. Aftercooler Outlet Connection	16. Seawater Intake
Jacket Water Outlet Connection	10. Pressure Cap	17. Seawater Discharge
Jacket Water Inlet Connection	11. Shut-Off Valve	18. Expansion Tank for Aftercooler Circuit
Expansion Tank	12. Duplex Full-Flow Strainer	19. Vent Line for Aftercooler Circuit
Jacket Water Pump	13. Heat Exchanger for Aftercooler	
Auxiliary Fresh Water Pump	14. Heat Exchanger for Jacket Water	

Figure 5.12 — Separate circuit aftercooled with heat exchangers.

5.19 Separate Circuit Aftercooled with Heat Exchangers with Aftercooler Seawater Recirculation

The separate circuit aftercooler cooling system must be designed with sufficient capacity for the hottest water and the higher ambient air conditions for operation in climates where both air and seawater temperatures run to extremes. This results in a cooler with excess capacity in cold seawater and warm air conditions. This can result in condensation in the engine's intake system, especially during prolonged light engine load. Extremely cold seawater in the aftercooler can also cause condensation when engine inlet air temperatures are relatively warm with high moisture content.

The thermostatic valve used should not allow the temperature of the water to the aftercooler to exceed 30°C (85°F). The heat exchanger and marine transmission oil cooler used must be sized for this maximum temperature. A thermostatically controlled 3-way valve that is equipped with a remote sensor to monitor the inlet manifold air temperature can be used. Adjust the remote sensor to ensure that the thermostatic valve does not permit recirculation when the inlet manifold temperature reaches 49°C (120°F).

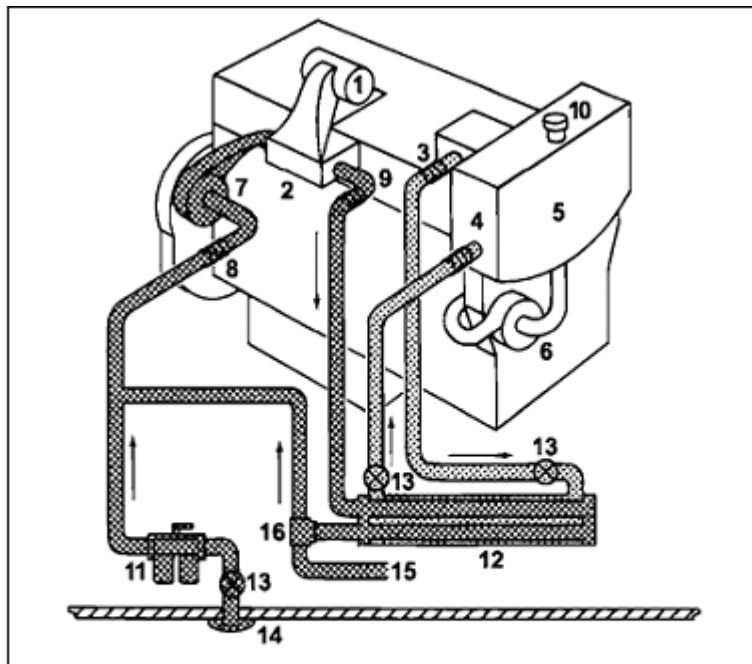

Turbocharger	7. Auxiliary Seawater Pump	12. Heat Exchanger
Aftercooler, Seawater Cooled	8. Auxiliary Seawater Inlet Connection	13. Shut-Off Valve
Jacket Water Outlet Connection	9. Aftercooler Outlet Connection	14. Seawater Intake
Jacket Water Inlet Connection	10. Pressure Cap	15. Seawater Discharge
Expansion Tank	11. Duplex Full-Flow Strainer	16. Bypass Valve Thermostatically-Controlled
Jacket Water Pump		

Figure 5.13 — Separate circuit aftercooled with heat exchangers with aftercooler seawater recirculation.

It is important that water be recirculated rather than be throttled to reduce flow. It is essential that unrestricted water flow through the aftercooler be maintained regardless of temperature conditions. Thermostatic valve plumbing must be sized to have internal diameters as large, or larger, than the inlet connection of the auxiliary pump. Use an air intake manifold temperature alarm set for 52 to 57°C (125 to 135°F) maximum to warn of a system malfunction.

In situations where condensation can be a problem, a corrosion-resistant water trap can be attached to the intake manifold(s) of the engine. Refer to Figure 5.14.

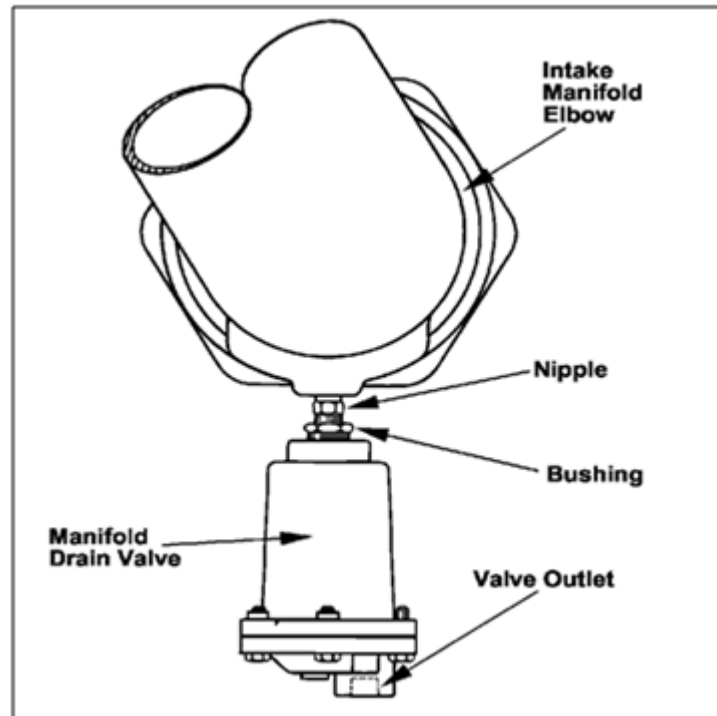

Figure 5.14 — Condensate valve group.

5.20 3600/C280 Combined Circuit System

Figure 5.15 is a typical combined circuit seawater cooling system designed for 3600/C280 Marine Engine applications. The fresh water circuit is cooled with seawater having a maximum temperature of 32°C (90°F). Since the lubricating oil and air aftercooler are cooled directly by water from the fresh water cooling circuit, only one fresh water heat exchanger is required. The aftercooler and oil cooler systems are an integral part of the basic engine design; nothing is required from the shipyard to pipe these systems. The arrangement reduces the seawater piping system and lowers the cost of expensive copper-nickel alloy piping, fittings, and valves. The result is less wear, corrosion problems, and maintenance.

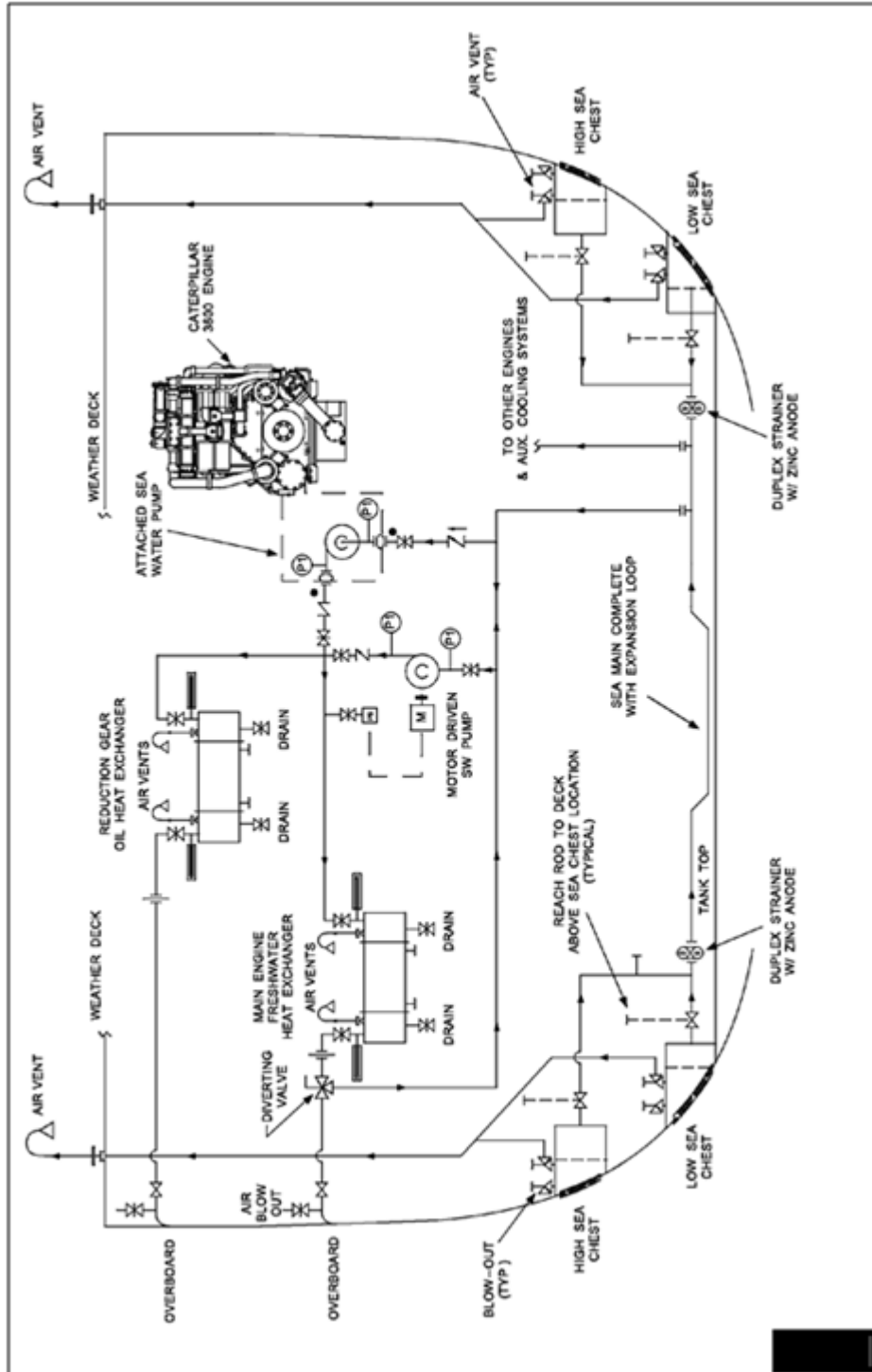

Figure 5.15 — Combined circuit seawater cooling system.

5.21 Sea Chest

The sea chest serves the following functions:

- Provides a low restriction connection for the seawater inlet plumbing.
- Provides a connection point for the sea cock. The sea cock is a seawater shutoff valve that is installed between the seawater inlet and the seawater inlet plumbing.
- Provides a way to separate air from the seawater required for cooling. Sea chests must have vent connections to allow air, forced under the hull during maneuvering, to be purged before it is able to reach the centrifugal seawater pump.

6.0 Suction Lines

The installation, size, and material of the seawater suction lines are extremely important.

The seawater suction lines should be below the vessel water line as much as possible and designed without air traps. Install a water pressure actuated check valve downstream of the strainer and as close to it as possible. The function of the check valve is to prevent water from draining out of the pump inlet while the pump is not operating and during cleaning of the strainer. Install a vent valve between the strainer and the check valve to allow venting of trapped air after cleaning the strainer and opening the sea cock. If the pump is above the vessel water line, install a piping loop above the pump inlet elbow to trap enough water to keep the pump and priming chamber filled.

6.1 Sea Valve

Where practical, all sea valves should be flanged gate or globe type. Lug type butterfly valves may also be used. Angle valves can be used where the installation of gate, globe, or butterfly valves are impractical. Sea valves should be controllable from a deck above the sea chest. Fit all valves with open/close indicators.

The recommended materials for sea chest or overboard discharge valves are cast steel, bronze, or nodular iron. Cast iron and malleable iron valves are not recommended. The valve seat, disk, and stem must be made from corrosion resistant material such as monel alloys.

6.2 Seawater Strainers

Strainers are required in order to protect the seawater pump, aftercooler, heat exchanger, and other cooling system components from foreign material in the seawater. The foreign material can plug and/or coat heat transfer surfaces, causing overheating of the engine and a shortened life of the components. If the foreign material is abrasive, it will erode pump impellers and soft metal parts, reducing their effectiveness.

Seawater strainers should be installed below the water line and as close to the seawater inlet or sea chest as possible. The strainers should also be installed adjacent to the sea cock and before the first component of the cooling system. The strainer must be installed so it can be easily cleaned, even in the worst weather conditions.

Although simplex strainers will adequately protect the engine, they require the seawater flow to be shut off during servicing. Duplex strainers can be cleaned without interrupting seawater flow or engine power and greater safety will result. It is strongly recommended to use a serviceable strainer in order to allow frequent cleaning.

Appropriately sized strainers will impose no more than 9 kPa (3 ft H₂O) restriction to flow at full seawater flow conditions. Suppliers can help in the proper selection of strainer size by providing the flow restriction of each size of strainer at varying water flow conditions.

Strainer media of 2.0 mm (0.079 in) diameter hole size or less is required. Strainer media of 1.6 mm (0.0625 in) diameter hole size is recommended in applications where sea grass and/or other debris are present, or cases when plugging of engine cooling components persists with the use of 2.0 mm (0.079 in) diameter media.

Schools of small fish, ice chips, and floating debris, such as plastic bags and plant material, can plug a clean strainer in a few seconds. When this happens, the differential pressure across the strainer will rise. This is an indication that the strainer should be cleaned. A differential pressure switch will provide an early warning of strainer plugging and resultant loss of engine cooling. In time, high engine water temperature alarms will also warn of a loss of seawater flow, but the differential pressure sensor will give early warning and the precise location of the problem. Even with a differential pressure sensor, the best practice is to clean the strainer frequently in order to ensure optimum engine performance and reduce stress on the cooling system components.

6.3 Priming

All seawater pumps (self-priming, centrifugal, and water ring pumps) MUST be filled with water prior to initial startup to ensure that the pump primes and also to avoid damaging the mechanical seal and impeller. Once initial priming has taken place, there is no need to refill the pump unless the system has been fully drained.

6.4 Seawater Pumps

Two centrifugal seawater pumps are typically required for marine propulsion applications; one is engine-driven and one electrically driven.

The engine-driven seawater pump is not self-priming so it must be located below the light water line of the ship or a priming arrangement must be provided. The engine power required to drive the Caterpillar supplied pump is shown in TMI.

The electrically-driven seawater pump capacity is determined by the type of cooler used, heat to be dissipated, and the seawater inlet temperature. The heat to be dissipated in the main engine fresh water heat exchanger is listed on the engine technical data sheets.

In many seawater systems, the pump supplying cooling water to the main engine heat exchanger also supplies cooling water to auxiliary heat exchangers, such as the reduction of the gear oil cooler. In these arrangements, the capacity of the seawater pump must be increased to allow for the additional requirements.

Start and stop control of the electric motor driven pump should be with a pressure switch installed in the common discharge line from the pumps. The switch starts the pump at 35 kPa (5 psi) and stops at 245 kPa (35 psi). The pipes connecting to the individual pumps must be at least equal to the pump suction diameter to minimize the restrictions in the suction piping. The suggested materials for seawater pumps are shown in Table 6.1.

Suggested Material for Seawater Pumps	
Component	Material/Type
Casing	Bronze
Impeller	Bronze
Shaft	Monel
Seal Type	Mechanical

Table 6.1 — Suggested materials for seawater pumps.

Caterpillar offers three types of seawater pumps.

- Rubber Impeller
- Water Ring
- Centrifugal

6.5 Rubber Impeller Seawater Pumps

Rubber impeller seawater pumps are characterized by excellent priming characteristics, though they often suffer relatively short life in abrasive waters.

6.6 Water Ring Seawater Pumps

Their priming characteristics are less than rubber impellers, but can lift up to 1.5 m (5 ft).

Caution: A goose neck may be necessary with these pumps to keep water in the pump for priming. The goose necks are made entirely of corrosion resistant metals with no elastomeric components.

6.7 Centrifugal Seawater Pumps

Centrifugal seawater pumps must be installed with their inlet below the boat's light waterline. Air allowed to enter centrifugal seawater pumps will likely result in loss of prime and probable engine damage due to loss of cooling. Do not start an engine equipped with a centrifugal pump unless the pump and priming chamber are full of water.

6.8 Seawater Piping

Flow restriction in the seawater suction piping will result in abnormally high engine temperatures which can lead to unscheduled shutdowns and, in severe cases, reduced engine life. To minimize flow restriction, pipes and hoses should be at least as large as the seawater pump suction opening.

If the distance to the through-hull fitting or sea chest is large or if many pipe elbows or bends in the hose are used, the pipe or hose size should be one size larger than the seawater pump opening (suction connection). In no case should the seawater pressure, measured at the seawater pump suction, be less than 24 kPa (3.5 psi) vacuum.

6.9 Piping System Materials

An excellent material for carrying seawater is of the copper-nickel alloys; CuNi 90/10 UNS C70600 is recommended. The cost of such piping makes its use unusual for all but the most critical systems.

The material of all the seawater piping should be the same, whenever practical. If parts of the seawater piping, made of different metals, make contact with each other, one of the metals will corrode, sometimes very rapidly.

The materials will corrode according to their position in the electromotive series. See the electromotive series chart in the section of Useful Tables to Designers of Cooling Systems.

Black iron pipe is often used in seawater service (replacement should be planned every two or three years).

If it is necessary to use pipe or other cooling system components of more than one material, avoid letting the dissimilar metals touch, even by mutual contact with an electrically conductive third material. Corrosion will be much more severe if a flow of electrons is able to pass freely from one of the metals to the other.

6.10 Fresh Water Heat Exchangers

Caterpillar supplies both shell and tube and plate and frame type coolers for the fresh water heat exchanger. The suggested materials for the shell and tube type heat exchangers are shown in Table 6.2.

Suggested Material for Shell and Tube Type Heat Exchangers	
Component	Material/Type
Shell	Steel
Heads	Iron
Tubes	90/10 CuNi
Tube Sheets	90/10 CuNi
Baffles	Steel

Table 6.2 — Suggested material for shell and tube heat exchangers.

A plate and frame type heat exchanger can be substituted for the shell and tube type. The suggested materials for the plate and frame heat exchanger are shown in Table 6.3.

Suggested Material for Plate and Frame Type Heat Exchangers	
Component	Material/Type
Frame	Mild Steel, Painted
Seawater Plates	Titanium or Aluminum Brass
Fresh Water Plates	Stainless Steel
Seawater Nozzles	Steel, Coated
Fresh Water Nozzles	Steel, Coated
Gaskets	Nitrile

Table 6.3 — Suggested material for plate and frame heat exchangers.

Classification societies may require a spray shroud around the plates to prevent liquid spray on equipment or personnel if a gasket fails.

The engine technical data sheets include heat rejection to the seawater for the various propulsion engine ratings. Add a safety margin of 10% to the total heat rejection to allow for heat exchanger fouling.

6.11 Marine Gear Oil Cooler

Reduction gear lube oil coolers normally use seawater taken directly from the engine seawater circulating system. The water flow required is obtained from the gear manufacturer.

6.12 Stern Tube Lubrication and Cooling

It is good practice to divert a small portion of the engine's seawater to lubricate and cool the stern tube and stuffing box (sometimes called the packing gland) before discharging it overboard. Generally, 4.5 L/min (1.19 gal/min) are adequate.

The engine's seawater strainer and the flow of water from the stuffing box end of the stern tube will tend to keep sand and other abrasive material out of the stern tube. Avoid using excessive quantities of the engine's flow of seawater, as this practice tends to increase the seawater system restriction, making the engine more likely to overheat.

6.13 Seawater Temperature

In some instances, the seawater temperature may be too low for the fresh water heat exchanger. It can be raised by installing a locally or remote controlled 3-way valve just inboard of the overboard discharge valve. The valve bypass feeds warmed discharge water directly back to the common suction pipe of the seawater circulating pumps.

Note: Pressure drop across the valve would normally be about 35 kPa (5 psi), and must be included in the seawater pump total dynamic head requirements.

6.14 Marine Growth

Marine plants and animals will enter seawater systems and take up residence in the piping and passages of the heat exchanger. Many forms of sea life are very comfortable within engine cooling system piping and will grow to a size that will threaten adequate cooling system flow. The lack of predators, darkness, and abundance of suspended food particles combine to create prime growth conditions for sponges, barnacles, and like creatures. Strainers are no protection against creatures that are microscopic in size during their infant stages of life.

Periodic operation in fresh water will exterminate salt water life in the cooling system. Likewise, periodic operation in salt water will exterminate fresh water life. However, the cooling system piping and passages must be cleaned to remove the deceased organisms. Heat exchangers must be periodically disassembled to remove marine growth in the heads and tubes.

Periodic chemical treatment combats marine growth. Chemical type and concentration must be carefully controlled to prevent deterioration of the seawater cooling system components. Contact a knowledgeable chemical supplier. Continuous low concentration chemical treatment via either bulk chemical or self-generating electrical processes is offered by various manufacturers.

High water temperature alarms, seawater pump pressure switches, and other instrumentation can be used and are highly recommended to warn of the gradual loss of seawater flow.

6.15 Potential Problems

6.15.1 Non-reinforced Seawater Pump Suction Hose

The vacuum inside the seawater pump suction hose can become quite high. If the hose is not internally reinforced, atmospheric pressure will collapse it. That will severely impede the flow of seawater with potentially dangerous results. Use a hose which is sufficiently strong to resist collapse due to high suction vacuum.

6.15.2 Internal Hose Deterioration

Some hose will shred internally, releasing bits of rubber which can plug cooling passages. It is a good practice to use good quality hoses. If users are unsure of the quality of their hoses, it is a good practice to examine the hoses internally at least once during their life. Replace them with a good quality hose every three years.

6.15.3 Achieving and Maintaining Seawater Pump Prime

Pump speeds and suction pressures must fall within certain limits for seawater pumps to achieve prime (start pumping water). The priming characteristics of Cat seawater pumps are available from the factory.

6.15.4 Seawater Discharge Through Exhaust System

Wet exhaust systems use seawater after it has passed through the various heat exchangers and coolers to cool the hot exhaust gases. After seawater is injected into the hot exhaust gas (generally immediately downstream of the engine's turbocharger), the temperature of the gas is reduced enough to allow use of sections of rubber hose, fiberglass-reinforced plastic pipe, or other similar materials to be used as exhaust pipe. It is critical that nothing interfere with the flow of seawater, which cools the exhaust gas. Anytime the engine is operating, the flow of seawater must be present.

6.16 Corrosion

6.16.1 Galvanic Corrosion in Seawater

When two dissimilar metals are electrically connected and both submerged in salt water, they form a battery and an electrochemical reaction takes place. In this process, one metal is eaten away. The rate of deterioration is proportional to a number of factors:

- The differential potential between the two metals on the electrochemical series (see Useful Tables to Designers of Cooling Systems).
- The relative areas of the two metals: If there is a small area of the more noble metal relative to the less noble metal, the deterioration will be slow and relatively minor. If there is a large area of the more noble metal, such as iron nails holding the copper sheathing to the wood, the wasting away of the iron nails will be violent and rapid.
- Stray electrical currents will accelerate the electrochemical reaction. Proper grounding and isolation from all electrical sources is required.

6.16.2 Dissimilar Metal Combinations to Avoid

- Bronze Propeller on Steel Shaft
- Mill Scale on Hull Plate (Internal or External)
- Aluminum Fairwaters Fastened to a Steel Hull
- Steel Bolts in Bronze Plates
- Bronze Unions and Elbows Used With Galvanized Pipe
- Bronze Sea Cocks on Iron Drain Pipes
- Brass Bilge Pumps on Boats With Steel Frames
- Stainless Steel Pennants on Steel Mooring Chains
- Bronze or Brass Rudder Posts With Steel Rudders
- Bronze Rudders With Steel Stopper-Chains
- Steel Skegs (Rudder Shoes) Fastened With Bronze or Brass Leg Screws
- Steel and Brass Parts in the Same Pump

Many of the combinations above follow this basic rule:

Do not put iron or steel, close to or connected with alloys of copper, in salt water.

6.16.3 The Protective Role of Zinc

If alloys of copper (bronze, brass), iron (steel), and zinc are all connected together and submerged in salt water, the zinc will be eaten away, protecting the iron (steel). It is necessary to have a metallic electrical connection to the metals to be protected. This is usually easy to accomplish on a steel hull. It is more difficult on a fiberglass hull since a special electrical connection may be required unless the zincs are connected directly to one of the metals, preferably the copper alloy.

Note: The zinc must never be painted or its protective quality will be lost.

Zinc anode rods are not necessary for keel cooled systems and should be removed when converting to fresh water system. For seawater cooled systems, zinc rods should only be installed on the discharge of the pump. Zinc rods installed on the inlet side of the pump after the strainer could result in pump damage.

When electrical contact is made through the fastening studs, it is desirable to put galvanized or brass bushings in the holes in the zinc rods so that contact will be maintained as the zinc rods corrode. Zinc anode rods should be initially inspected after the first fifty hours of operation. The condition of the zinc rod will determine how often the zinc rods should be inspected for possible replacement. As zinc rods work, a white, crust-like deposit of zinc oxides and salts form on the surface. This is normal. If it does not form and the zincs remain clean and like new, they are not protecting the structure. This would indicate that the zinc anodes are either not connected electrically to the less noble metal or the anode is not located in the right location to protect the less noble components. This should be corrected immediately as the less noble metal will quickly be eaten away by corrosion.

Zinc anodes are available in two types; threaded and press fit. The press fit type is where the zinc anode is pressed into the threaded plug. The threaded type is where the zinc anode is threaded into the threaded plug that is inserted into the desired plumbing location. Caterpillar recommends using the threaded type. The press fit type can fail prematurely and fall out of the threaded plug. Then the desired protection to the system will not be provided. Zinc anodes are made in two types of material. Type 1 contains zinc and cadmium. This is the most common standard type of anode. Type 2 contains almost pure zinc. This is the standard for underground mining applications. Caterpillar recommends using only the Type 2 threaded anodes as the anode will last longer, and the cadmium is a hazardous material to the environment. Inspect the zinc plugs within twenty-four hours of filling the piping with seawater. If no significant corrosion is noted, inspect them again after fifty operating hours. Inspect them again in seven days of seawater submersion. If no significant deterioration is noted, inspect them again in sixty to ninety days. Thereafter, inspect on a regular basis determined by the life of the zinc anodes and replace them when necessary. Time after submersion is a critical factor since corrosion continues when the engine is not running.

Seawater flow rate is critical to system component life. A protective film is produced on the surface of copper nickel if fresh clean oxygenated seawater continuously flows at a minimum rate of 1 meter/second (3.28 feet/second). Too little or too much flow rate can cause component failure. The system should not be left idle or stagnant (without circulation flow) whenever possible.

If the system is to be shut down for more than a few hours then the system should be drained and blown dry with compressed air. Localized pitting of components can occur quickly if salt water is left uncirculated in the plumbing. A minimum flow rate of 1 meter/second (3.28 feet/second) should be maintained even if the engine is not running. Flow rates greater than 3.5 meters per second (11.48 feet/second) can cause the protective film to be eroded.

Pressure taps should be installed before and after the seawater heat exchanger to allow for flow measurement.

6.17 Contaminants

Flow rates should not exceed 2 meters/second (6.6 feet/second) if the seawater contains sand or debris to prevent erosion. Contaminants in the cooling system can cause component failure quickly if the zinc anodes are not properly installed and maintained. Dissimilar metals are common on tubes and piping from the manufacturer due to the machinery forming the material or from fabrication and installation of the plumbing system. This can leave small particles of metal on the formed metal and can cause pitting of the formed piece if not protected. Even with washing and cleaning, some of these particles remain on the surface of the desired component. This is common for many materials and the effect is accelerated when seawater is present in the system. This is why it is very critical to properly maintain the zinc anodes as they are the protection for the entire seawater cooling system. Without their protection, failure can happen in a matter of hours.

6.18 Electrochemical Series

The following series of elements is listed in order of highest reactivity or corrosiveness to lowest, as they relate to cooling system components.

Corroded End — Least Noble

- Magnesium
- Magnesium Alloys
- Zinc
- Beryllium
- Aluminum Alloys
- Cadmium
- Mild Steel or Iron
- Cast Iron
- Low Alloy Steel
- Austenitic Cast Iron
- Aluminum Bronze
- Naval Brass
- Yellow Brass
- Red Brass
- 18-8 Stainless Steel (Active)
- 18-8-3 Stainless Steel (Active)
- Lead-Tin Solders
- Lead
- 70-30 Copper Nickel
- Tin
- Brasses
- Copper
- Bronzes
- Copper-Nickel Alloys
- Monel
- Admiralty Brass, Aluminum Brass
- Manganese Bronze
- Silicon Bronze
- Tin Bronze
- Silver Solder
- Nickel (Passive)
- Chromium-Iron (Passive)
- Stainless Steel (Passive)
- 18-8-3 Stainless Steel (Passive)
- Silver
- Ni-Cr-Mo Alloy 8 Titanium
- Ni-Cr-Mo Alloy C
- Gold
- Platinum
- Graphite

Protected End – Most Noble

6.19 General Corrosion

A protective film is produced on the surface of copper-nickel if fresh clean oxygenated seawater continuously flows at a minimum rate of 1 meters/second (3.3 feet/second). If long stagnant conditions are expected, blow-drying the system is recommended.

Flow rates greater than 3.5 meters/second (11.5 feet/second) can cause the protective film to be eroded. Polluted water containing sulfides is especially corrosive to copper alloys and should be avoided.

6.20 Erosion

Flow rates should not exceed 2 meters/second (6.56 feet/second) if the seawater contains sand or debris.

Pressure taps should be installed before and after the seawater heat exchanger to allow for flow measurement.

7.0 Watermakers, Domestic Water Heaters, Cabin Heaters

Watermakers, domestic water heaters, and cabin heaters can put normally-wasted jacket water heat to work. This has the potential for recovery of approximately 15% of the fuel input energy.

Certain aspects of the engine cooling system must be thoroughly understood to avoid misapplication. For example, an engine will only produce significant amounts of waste heat if there is a significant load on the engine. Many engines in marine service are lightly loaded for large parts of their life and are poor choices for installation of watermakers, domestic water heaters, and cabin heaters. When an engine is lightly loaded, almost all of the engine's jacket water flow goes through a bypass line, from the thermostat housing to the jacket water pump inlet, to maintain a constant high flow through the engine's cooling passages.

Watermakers, domestic water heaters, and cabin heaters can overcool an engine. If the watermaker, domestic water heater, or cabin heater extracts too much heat from the flow of jacket water, the engine's water temperature sensors/thermostats will sense the engine cooling jacket is operating at a dangerously low temperature. It will attempt to correct the condition by reducing the external flow of cooling water. If there are automatic controls on the watermaker, domestic water heater, or cabin heater, it may shut off having sensed insufficient flow for continued operation. This leads to a troublesome condition of repetitive starting and stopping of the watermaker, domestic water heater, or cabin heater. Automatic control of these devices has proven troublesome and is not recommended. Consider the use of auxiliary water heaters so during periods of light engine load, adequate amounts of heat can be sent to the watermaker, domestic water heater, or cabin heater.

Cooling water piping to and from the watermakers, domestic water heaters, and cabin heaters must not allow entrained air/gases to collect. Trapped air/gases will displace the water required to carry engine heat to the watermakers, domestic water heaters, and cabin heaters and interfere with proper operation. Trapped air/gases can be vented by installing small, approximately 3 mm (0.125 in), inside diameter vent lines. The vent lines should carry air/gases from the high points in the domestic water heater and its associated piping to a higher point in the engine jacket water cooling circuit; this is normally an installer-supplied auxiliary expansion tank.

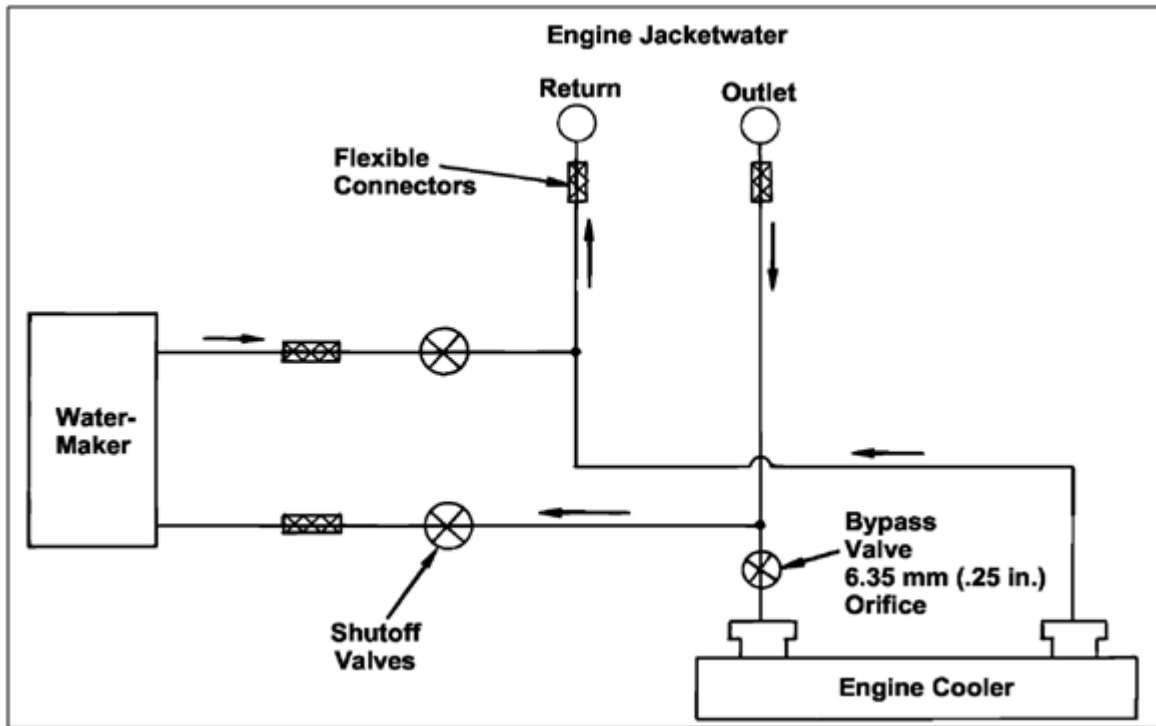

Figure 7.1 — Manual control watermaker circuit.

See the engine general dimension drawing for the connection locations of points on the engine where water for this purpose should be extracted and returned. However, please note that not all engine cooling system designs have connections for watermakers.

7.1 Watermaker Controls

The watermaker controls may be manually operated valves or thermostatically controlled valves. Any failure of the watermaker control system, such as electrical or air, must shut off jacket water flow to the watermaker and return the flow to the engine heat exchanger. The thermostat valve, shown in Figure 7.2, would have a temperature setting that will not interfere with the engine thermostats. This valve should begin to divert water flow to the engine heat exchanger at no more than 88°C (190°F) and be fully diverting at 96°C (205°F). For safety, the bypass valve(s) in the engine heat exchanger circuit should contain 6.35 mm (0.25 in) orifices so there will be a slight water flow in case all valves are inadvertently left closed. This orifice is then required to assure water flow to actuate an alarm system. The slight water flow from the orifice will also reduce the possibility of thermal shock on the engine cooler. If the watermaker cannot handle the full heat rejection of the engine and/or cannot handle the full water flow of the engine, the automatic system must be used.

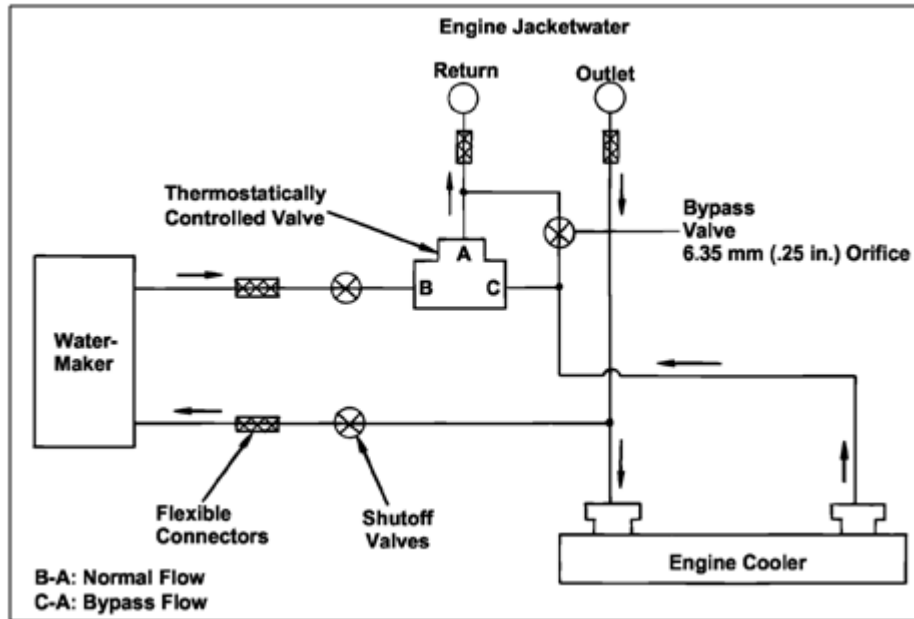

Figure 7.2 — Automatic control watermaker circuit.

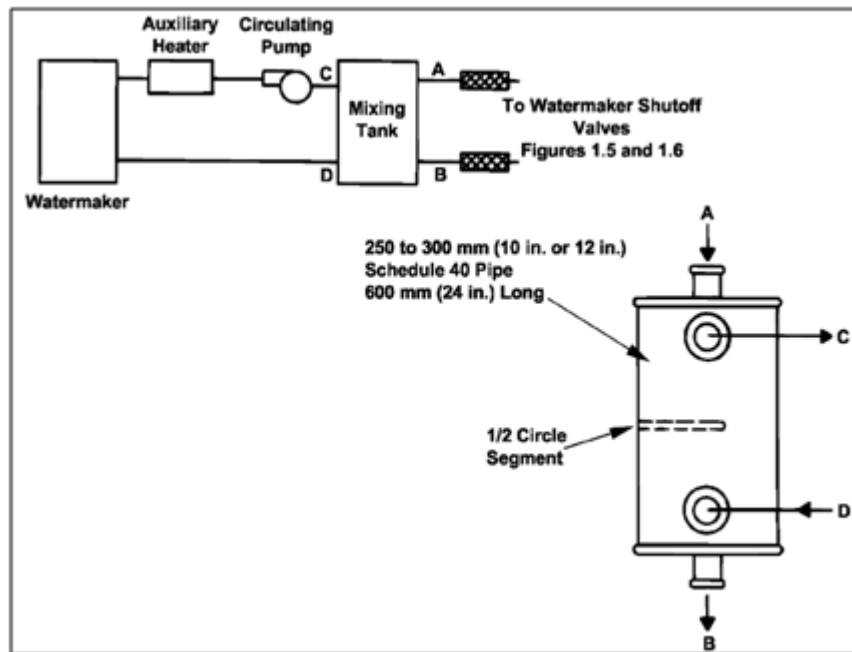

Figure 7.3 — Typical mixing tank.

7.2 Interconnecting Engines

Several problems arise from interconnection of several engines: unequal water flow, one failure shuts down all engines and excessive external head pressures are just a few. For these reasons, separate connection of one engine per watermaker is recommended. It is the customer's responsibility to provide a system that is compatible with the engine cooling system in all modes of operation.

7.3 When the Watermaker is Far From the Engine

When the watermaker is a long distance from the engine or where the watermaker requires a constant water flow, a mixing tank and circulating pump is required. Do not use a circulating pump by itself because the circulating pump head pressure will damage the engine thermostats in the event they are closed. Although the mixing tank is not supplied by Caterpillar, it can be used with either of the suggested circuits. An auxiliary electrical heater may be installed, as shown in Figure 7.3.

7.4 Monitoring Systems/Alarms/Shutdowns

7.4.1 Emergency Systems

Many marine applications require the capability to connect emergency cooling water pumps into the engine's cooling system. Cat engines can be provided with these optional connections when necessary. This is a specific requirement of marine classification societies for seagoing single propulsion engine applications.

The requirement applies to both the engine jacket water and auxiliary (sea or fresh) water systems. The purpose of the emergency systems is to ensure cooling if either the jacket water or auxiliary (sea or fresh) water pump should fail. The customer-supplied emergency pumps should provide flow equal to the failed pump to permit operation at full, continuous power with the emergency systems. For pump flow requirements of engine-mounted pumps, refer to TMI or consult a Cat dealer. If reduced power operation is acceptable, reduced flows can be utilized. Use flexible connectors at the engine to protect the piping and engine.

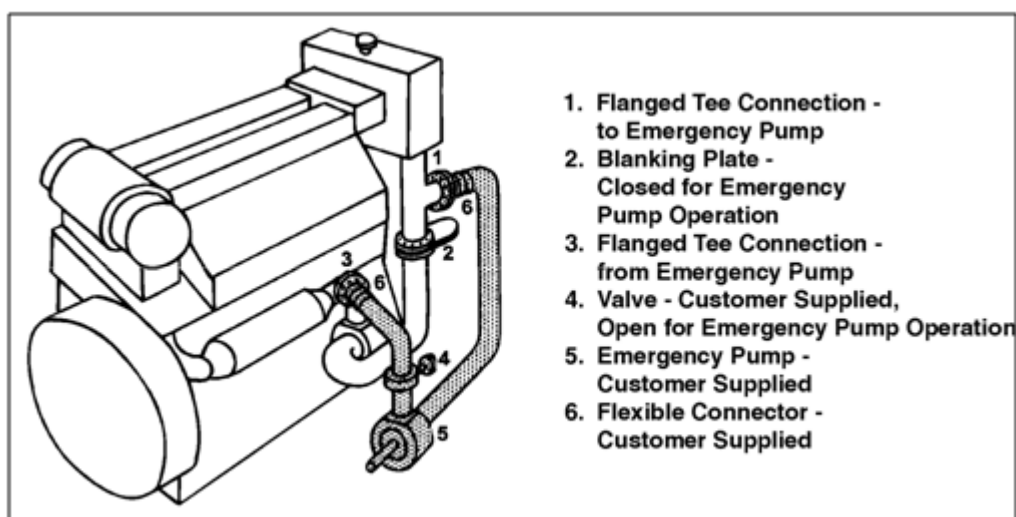

Figure 7.4 — Emergency jacket water pump connections (location of jacket water pump may vary).

7.4.2 Jacket Water Pump Connections

The optional Cat emergency jacket water connections, available for the large vee engines, meet the requirements of the engine and the marine classification societies. Use of these connections permits the emergency system to utilize the normal jacket water as the coolant and to bypass the engine-mounted jacket water pump. The system includes a blanking plate or valve to direct jacket water to the emergency system and flanged connection points on the engine for the emergency system piping. Figure 7.4 is a schematic diagram of the system properly connected. The customer-supplied emergency water pump should provide flow equal to the failed pump.

The use of seawater in the engine jacket water system is not recommended. If seawater must be used in the jacket water system to ensure the safety of the ship in an emergency situation, use the lowest engine power level commensurate with the sea state. On reaching port, the jacket water system must be thoroughly flushed and cleaned.

7.4.3 Auxiliary Seawater Pump Connections

All emergency seawater cooling connections are to be provided by the installer and connected, as indicated in Figure 7.5, illustrating emergency auxiliary pump connections. The emergency seawater pump should provide flow equal to the failed pump.

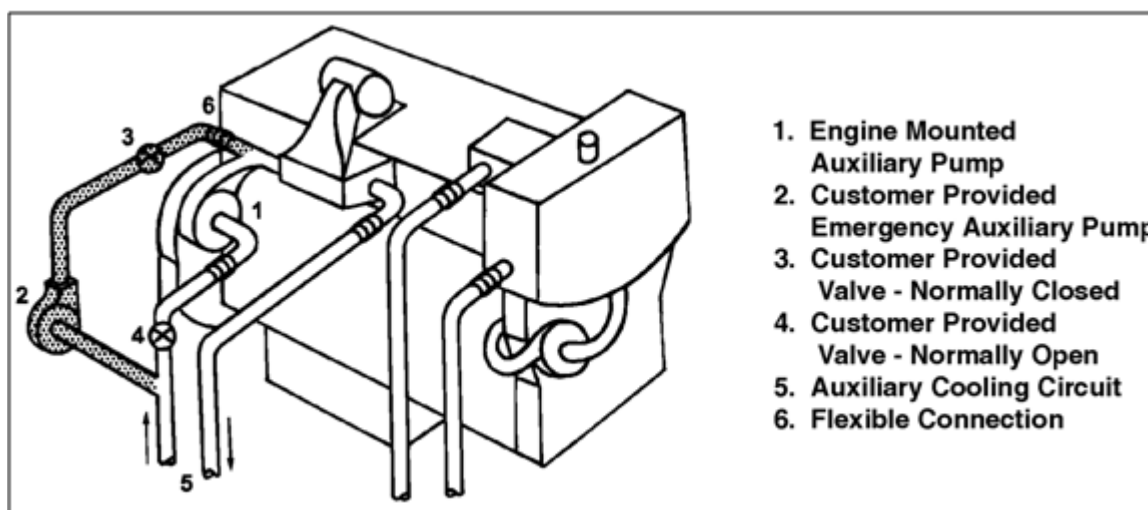

Figure 7.5 — Emergency auxiliary pump connections.

7.4.4 Auxiliary Freshwater Pump Connections

All emergency connections for separate keel cooled aftercooler circuits are to be provided by the installer and connected, as indicated in Figure 7.4.

The flow required for the emergency separate keel cooled aftercooler pump should equal the failed pump. The use of seawater in the separate keel cooled aftercooler circuit is not recommended. The engine-mounted pump and lines are of ferrous material and have low corrosion resistance in seawater. If seawater must be used in an emergency to ensure the safety of the ship, thoroughly flush the system, as mentioned in the jacket water section, and inspect the parts for corrosion damage and deposits.

7.5 Central Cooling Systems

A central cooling system is defined as one which cools multiple engines and which combines many individual cooling system components (heat exchangers and pumps) into a large central one. However, there are both advantages and disadvantages to a central cooling system that must be considered when making that determination. A typical marine central cooling system diagram is shown in Figure 7.6.

7.5.1 Advantages of a Central Cooling System

- A central cooling system will reduce the extent of the seawater piping system and thereby reduce wear, corrosion, and maintenance.
- The reduced extent of the seawater system will also significantly reduce the amount of shipyard labor required to install such a system.
- The smaller number of components will reduce the cost of procurement, inventory, and support with repair units.
- Larger components are generally more robust and can be expected to last longer.

7.5.2 Disadvantages of a Central Cooling System

- A disadvantage of a central cooling system involves the additional electrical loads required for the additional circulating pumps, and the somewhat higher capital and installation costs associated with them.
- Another disadvantage is that in such a system, due to the number of potential modes of operation. For example: with a system containing three engines, one heat exchanger, and two pumps, there will be 162 possible combinations or modes of operation.

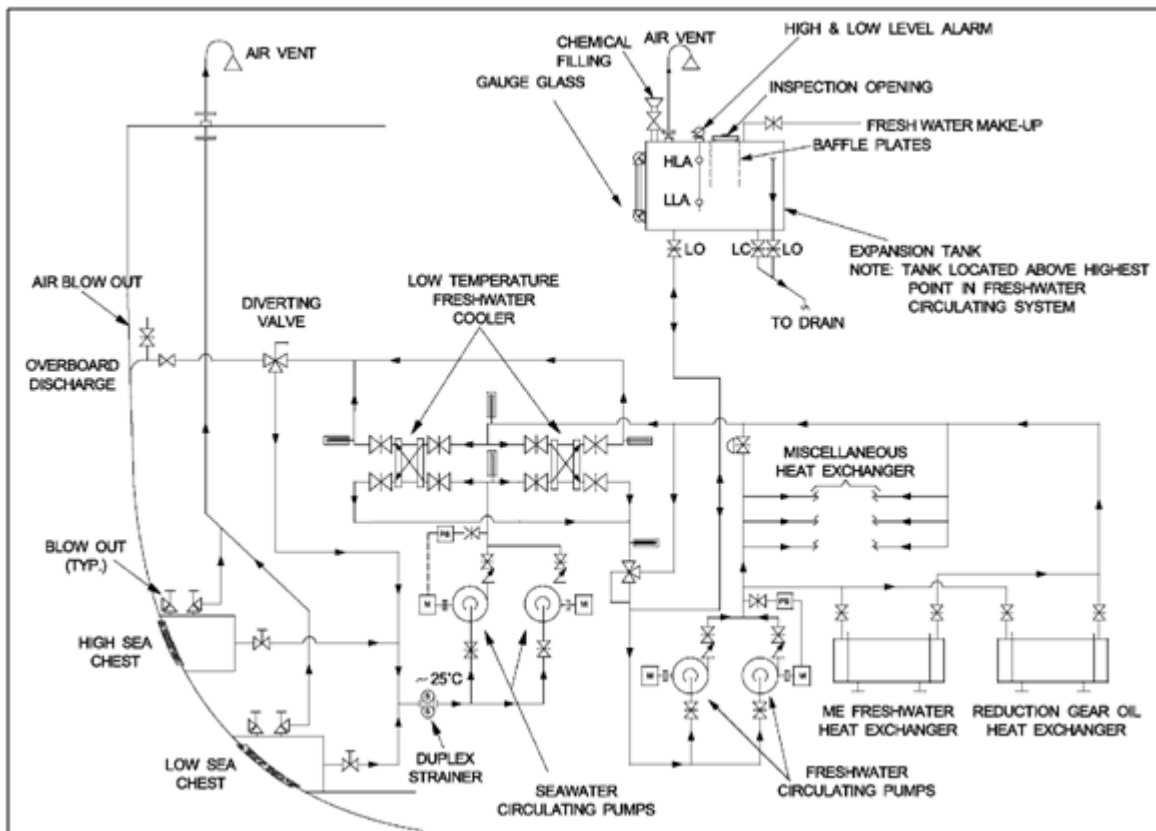

Figure 7.6 — Typical marine central cooling system.

7.5.3 Suggestions for Design of a Successful Central Cooling System

- **Flow Control:** There are upper and lower limits to the allowable flow through an engine. The system must be able to throttle the flow through each engine independently.
- **Temperature Control:** The heat exchanger must be capable of delivering the proper amount of cooling, proportional to engine load.
- **Load Control:** The amount of external water flow through a Cat engine is directly proportional to the engine's work load. The greater the load, the greater the amount of cooling required and the more water the engine's internal cooling circuitry will discharge for cooling. At light loads, the engine's temperature controls will bypass the external portion of the engine cooling system, recirculating virtually all of the coolant. If the water pressure presented to an engine by a central cooling system is too high, the proper operation of the engine's temperature controls may be overridden, and the engine will suffer over or under cooling problems. It is very difficult to adequately balance and control the flow through several engines, all of which might be operating at widely varying loads. Keep each engine's jacket water system independent of all the others, using a separate jacket water heat exchanger at each engine. The load control problems are not economically solvable. The water pressure on an engine jacket water inlet cannot be allowed to exceed an engine's published pressure limits. Economic factors may encourage many designers to use higher pressures, but this must be discouraged, as higher pressures will significantly reduce water pump seal life.
- **Ring Main:** Provide a ring main of fresh water, circulated by at least two parallel water pumps. A third water pump should be kept in reserve to maintain operation when either of the other pumps require maintenance. Each pump should be identical for ease of parts inventory and maintenance. The ring main is the water source for each engine's independent cooling system. The temperature and pressure of the water in the ring main do not need precise control. Each engine should have an engine-driven, auxiliary (not jacket water) water pump. This pump will draw water from the ring main and return it back to the ring main, downstream.
- **Pressure Control Valve:** A valve must be installed to balance the system if one or more of the heat exchangers are shut off. In response to pressure differences across the exchangers, the valve will open or close and try to maintain the pressure at its original setting. As a result, the water flowing through the remaining heat exchangers will remain unchanged, and the temperature relationships will remain constant.

8.0 Reference Material

8.1 Media List

The following information is provided as an additional reference to subjects discussed in this manual. The following publications are available for order through you Cat dealer.

Note: Refer to this publication, the respective product data sheet, and to the appropriate Operation and Maintenance Manual for product application recommendations. Information contained in the listed publications is subject to change without notice.

AECQ1042	Caterpillar Product Line Brochure
GECJ0001	Cat Shop Supplies and Tools (catalog)
PEDP7036	S•O•S Fluid Analysis
PECP9067	One Safe Source (catalog)
PEDP9131	Fluid Contamination – The Silent Thief
PEEP5027	Label – ELC Radiator Label
PEHJ0008	Data Sheet, “Cat DEO™ (SAE OW-30)” (Canada and United States)
PEHJ0021	Data Sheet, “Cat DEO (SAE 10W-30 and SAE 15W-40)” (Worldwide- Except North America, Egypt, Saudi Arabia, and Brazil)
PEHJ0059	Data Sheet, “Cat DEO (SAE 10W-30 and SAE 15W-40)” (North America – Canada, Mexico, and United States)
PEHJ0067	Data Sheet, “Cat ELC (Extended Life Coolant)” (Worldwide)
PEHJ0068	Data Sheet, “Cat Advanced Efficiency Engine Oil Filter”
PEHJ0072	Data Sheet, “Cat DEO (SAE 10W-30 and SAE 15W-40)” (Brazil)
PEHJ0082	Data Sheet, “Cat Fuel/Water Separators and Prime Time Priming Pumps”
PEHJ0091	Data Sheet, “Cat DEO (SAE 10W-30 and SAE 15W-40)” (Egypt and Saudi Arabia)
PEHJ0093	Data Sheet, “Cat DEO (SAE 30 and SAE 40)” (For use in 3600 Series diesel engine and for use in older precombustion chamber diesel engine. Do NOT use in direct injected 3500 Series and smaller diesel engines.
PEHP6028	Data Sheet, “Cat Ultra High Efficiency Air Filters”
PEHP7032	Data Sheet, “Radial Seal Air Filters”
PEHP7045	Data Sheet, “Fuel Contamination Control for 3500 Series Cat Engines”
PEHP7046	Data Sheet, “Fuel Contamination Control”
PEHP7052	Making the Most of S•O•S Services
PEHP7057	S•O•S Coolant Analysis
PEHP7062	Data Sheet, “Cat DEO SYN (SAE 5W-40)”
PEHP7076	Understanding S•O•S Services Tests
PEHP7077	Data Sheet, “Cat Turbine Pre-Cleaners”
PEHP9013	Data Sheet, “Air Filter Service Indicator”
PEHP9554	Data Sheet, “Cat DEAC Diesel Engine Antifreeze/Coolant) (Concentrate)”
PEPP5027	Label – ELC Radiator Label

PELJ0176	Cat ELC (Extended Life Coolant) 223-9116 Dilution Test Kit
PELJ0179	Cat Engine Crankcase Fluid-1 Specifications (CAT ECF-1) (All International Markets)
PEWJ0074	Cat Filter and Fluid Application Guide
LEWQ7235	Engine Data Sheet 50.5 – Cooling System Field Test
REHS1063	Special Instruction – Know Your Cooling System
SEBD0970	Coolant and Your Engine
SEBU6250	Cat Machine Fluids Recommendations
SEBU6251	Cat Commercial Diesel Engine Fluids
SEBU6400	Cat Gas Engine Lubricant, Fuel, and Coolant Recommendations
SEBU7003	3600 Diesel Engine Fluids Recommendations for Lubricants, Fuels, and Coolants
SENR9620	Improving Fuel System Durability
WECAP	Web Engineering Cataloging and Procuring Website
LEXH6521	Air to Air Aftercooling System Guide
REHS7296	Instructions for Use of Cat Coolant Conditioner for Aluminum Components

9.0 Appendices

9.1 Appendix A

9.1.1 Coolant Flow Calculation and Determining Allowable External Restriction

As stated earlier in this guide, the cooling system only functions as a complete closed circuit. The circulating pump provides a pressure rise to drive the coolant through the system; the other parameters, coolant flow and total system restriction, are inversely related and must be determined from one another. Caterpillar's documentation for engine-mounted coolant pump performance takes into account the pressure rise performance for the pump and the flow restriction found in the on-engine coolant paths. The curves published for each engine-pump combination relate the achieved coolant flow rate to the added external restriction that will produce that flow rate. The target flow requirement is a function of the heat rejection rates predicted for the engine operating at the site conditions on the specified fuel. The process begins with summing the total heat rejection for each cooling circuit on the engine then completing the coolant flow calculation for each based on those totals.

Heat rejection and coolant flow are related by the equation:

$$\text{Flow (L/min)} = \frac{(\text{Heat Rejection (kW)})}{(\text{Temperature Rise (}^\circ\text{C)} * \text{Density (kg/L)} * \text{Specific Heat (kW-min)/kg} \cdot ^\circ\text{C})}$$

$$\text{Flow (gal/min)} = \frac{(\text{Heat Rejection (Btu/min)})}{(\text{Temperature Rise (}^\circ\text{F)} * \text{Density (lb/gal)} * \text{Specific Heat (Btu/lb} \cdot ^\circ\text{F)})}$$

Heat Rejection is the total heat rate produced in each circuit. It can be summed up by identifying the heat rejection quantities for each heat source on each circuit, applying the appropriate tolerance to each, then adding them together. Any reserve capacity values (calculation safety margin, cooler fouling factor, etc.) should be built into each of these resulting totals. The individual heat load values, tolerances, and cooling circuit configuration definitions appear in the performance data for each engine rating reported on the technical data sheets found in TMI for each engine/rating. Other considerations:

- Turbocharged-Aftercooled engine ratings may include an Aftercooler Heat Rejection Factor (ACHRF) chart to account for the increased compression heating of the turbocharger when the engine is adjusted for site altitude and ambient temperature. The ACHRF must be included in the auxiliary circuit calculation that includes the aftercooler heat rate.
- Two-stage aftercooled engines must split the total ACHRF heat load across the circuits used on each stage. The portion of the total ACHRF heat load carried by each circuit (the "proportioning factor") is indicated in the notes of the technical data sheet for each engine/rating.

Temperature Rise is the allowable increase in temperature for the coolant across the cooling circuit ($T_{\text{outlet}} - T_{\text{inlet}}$). Allowable temperature rise values should be published for each engine configuration, in TMI or in dedicated published guides such as Technical Information sections of the A&I Guide, Marine Project Guides, or other similar sources.

Density and *Specific Heat* are inherent properties of the coolant. The following table provides reference values for these properties for the three generally approved coolant types.

Density and Specific Heat Values for Common Coolant Types			
Coolant	Density kg/L (lb/gal)	Specific Heat (kW·min)/(kg·°C)	Specific Heat Btu/(lb·°F)
Pure Water	0.98 (8.1)	0.071	1.00
50% Ethylene Glycol + 50% Water	1.03 (8.6)	0.060	0.85
50% Propylene Glycol + 50% Water	1.01 (8.4)	0.065	0.92

Table 9.1

Worksheets are provided at the end of this Appendix that provide a visually-organized format for completing these calculations. Examples are included following the worksheets to illustrate the heat rejection summation for both single- and two-stage aftercooled applications.

Automated calculation tools such as Gas Engine Rating Pro (GERP) may also complete these heat rejection summation calculations for you. Please check to see if such a time saving aid is available for your engine/rating.

Once the required coolant flow rate is calculated, it can be applied to the Allowable External Restriction curves published for each coolant pump. These curves will determine the restriction to flow that can be added in the external system to achieve the target flow rate. Once a restriction target is established, the effectiveness of the external cooling system design concept can be evaluated. This is done by comparing the target external restriction to an estimate of the restriction for the design concept. If the concept estimate exceeds the target value, the design should be redeveloped to reduce restriction. Repeat this process until an acceptable match is achieved. An approach to estimating external system restriction is detailed in 9.2 Appendix B.

9.1.2 Cooling Circuit Total Heat Load Worksheet

Engine Model _____ Rating _____ kW / bhp @ _____ rpm

Performance Data Number _____ Site Conditions _____ m / ft @ _____ °C / °F

1. Calculate individual totals, including tolerances and modification factors. Write in heat rates and ACHRF from the performance technical data sheet (write in over pale text).

Multiply down each column to determine totals for each individual heat source.

Base heat rate	JW	OC	AC	AC1	AC2
Tolerance	1.10	1.20	1.05	1.05	1.05
ACHRF	[does not apply]	[does not apply]	ACHRF	[does not apply]	[does not apply]
Total heat rate	Total JW	Total OC	Total AC	Total AC1	Total AC2

2. For the table below, enter the totals from Step 1 only for those heat loads on each cooling circuit, as described on the technical data sheet for the engine rating.

Add across to determine the total heat rate for each circuit.

A	B	C	D	E	Add A through E
Total JW	Total OC	Total AC	Total AC1	Total AC2	High Temp Total
Total JW	Total OC	Total AC	Total AC1	Total AC2	Low Temp Total

3. For two-stage aftercooled configurations, add the proportioned ACHRF. Use proportioning factor from the equation found in the "Notes" section of the performance technical data sheet.

F	G	H	J	K	L	Add K + L
Proportion Factor	(AC1+AC2) base values	(ACHRF-1)	1.05	multiply F x G x H x J	copy step 2 total	High Temp Total
Proportion Factor	(AC1+AC2) base values	(ACHRF-1)	1.05	multiply F x G x H x J	copy step 2 total	Low Temp Total

EXAMPLE of worksheet
Completed for single-stage
aftercooled applications

Cooling Circuit Total Heat Load Worksheet

Engine Model G3516 LE Rating 1340 bkw (bhp) @ 1400 rpm
Performance Data Number DM8618 Site Conditions 5000 m (ft) @ 100 °C (°F)

1. Calculate individual totals, including tolerances and modification factors. Write in heat rates and ACHRF from the performance technical data sheet (write in over pale text). Multiply down each column to determine totals for each individual heat source.

Base heat rate	42115	6281	9547	AC1	AC2
Tolerance	1.10	1.20	1.05	1.05	1.05
ACHRF	[does not apply]	[does not apply]	1.33	[does not apply]	[does not apply]
Total heat rate	46327	7538	13333	Total AC1	Total AC2

2. For the table below, enter the totals from Step 1 only for those heat loads on each cooling circuit, as described on the technical data sheet for the engine rating. Add across to determine the total heat rate for each circuit.

A	B	C	D	E	Add A through E
46327	7538	Total AC	Total AC1	Total AC2	High 53865 al
Total JW	Total OC	13333	Total AC1	Total AC2	Low 13333 al

3. For two-stage aftercooled configurations, add the proportioned ACHRF. Use proportioning factor from the equation found in the "Notes" section of the performance technical data sheet.

F	G	H	J	K	L	Add K + L
Proportion Factor	(AC1+AC2) base values	[ACHRF-1]	1.05	multiply F x G x H x J	copy step 2 total	High Temp Total
Proportion Factor	(AC1+AC2) base values	[ACHRF-1]	1.05	multiply F x G x H x J	copy step 2 total	Low Temp Total

115

EXAMPLE of worksheet completed for two-stage aftercooled application

Cooling Circuit Total Heat Load Worksheet

Engine Model G3516B Rating 1380 kW (bhp) @ 1400 rpm
 Performance Data Number DM8800 Site Conditions 5000 m (ft) @ 100 °C (°F)

1. Calculate individual totals, including tolerances and modification factors. Write in heat rates and ACHRF from the performance technical data sheet (write in over pale text). Multiply down each column to determine totals for each individual heat source.

Base heat rate	23412	4475	AC	10046	5358
Tolerance	1.10	1.20	1.05	1.05	1.05
ACHRF	[does not apply]	[does not apply]	ACHRF	[does not apply]	[does not apply]
Total heat rate	25754	5370	Total AC	10549	5626

2. For the table below, enter the totals from Step 1 only for those heat loads on each cooling circuit, as described on the technical data sheet for the engine rating. Add across to determine the total heat rate for each circuit.

A	B	C	D	E	Add A through E
25754	5370	Total AC	10549	Total AC2	High 41673
Total JW	Total OC	Total AC	Total AC1	5626	Low 5626 total

3. For two-stage aftercooled configurations, add the proportioned ACHRF. Use proportioning factor from the equation found in the "Notes" section of the performance technical data sheet.

F	G	H	J	K	L	Add K + L
Proportion 0.9	(AC1+AC2) 15404	(A) 0.35	1.05	multiply 5095	5095	High Temp 41673
Proportion 0.1	(AC1+AC2) 15404	(A) 0.35	1.05	multiply 567	567	Low Temp 5626
						46768
						6193

9.2 Appendix B

9.2.1 Estimating External System Restriction

Appendix A showed how to determine the external restriction that could be added to the engine's cooling circuits to arrive at a coolant flow rate that fulfills the heat rejection requirements of the engine/rating. This discussion provides simple tools to help estimate the restriction present in a proposed external system design. By estimating the restriction first, adjustments can be made to the design to better align it with the restriction requirements before any detailed review of restriction is undertaken.

Details of the external system design, both major and minor, can and do influence the restriction to flow. Examples of design choices that affect restriction include:

- The diameter and total connected length of piping in the system
- The number, size, and type of valves and fittings included in the design
- The number, size, and design of the heat transfer devices in the circuit
- The coolant flow rate required for adequate heat rejection from the engine

Not only does the number of 90° elbows in the system affect the restriction total, but the choice of short- versus long-radius elbows does as well. The general guiding principle for avoiding restriction is to always remember fluids do not want to change. All changes in direction or diameter will contribute to the restriction to flow.

Another principle to keep in mind is that 'speed is bad'. Any design details that increase coolant velocity also increase the resistance to flow, but high fluid velocities can also lead to erosion and other effects that can limit the service life of the cooling system components. The table below provides some general guidelines for velocity limits to observe in certain portions of the system.

Recommended Maximum Fluid Velocities		
	m/sec	ft/sec
Pressurized piping	4.5	15
Pressurized thin-wall tubing	2.0 – 2.5	6.5 – 8.0
Pump suction (inlet)	1.5	5.0
Deaeration zones	0.6	2.0

Table 9.2

The tools presented on the following pages are intended to aid in estimating the flow-restriction behaviors of various selection options in the external system design.

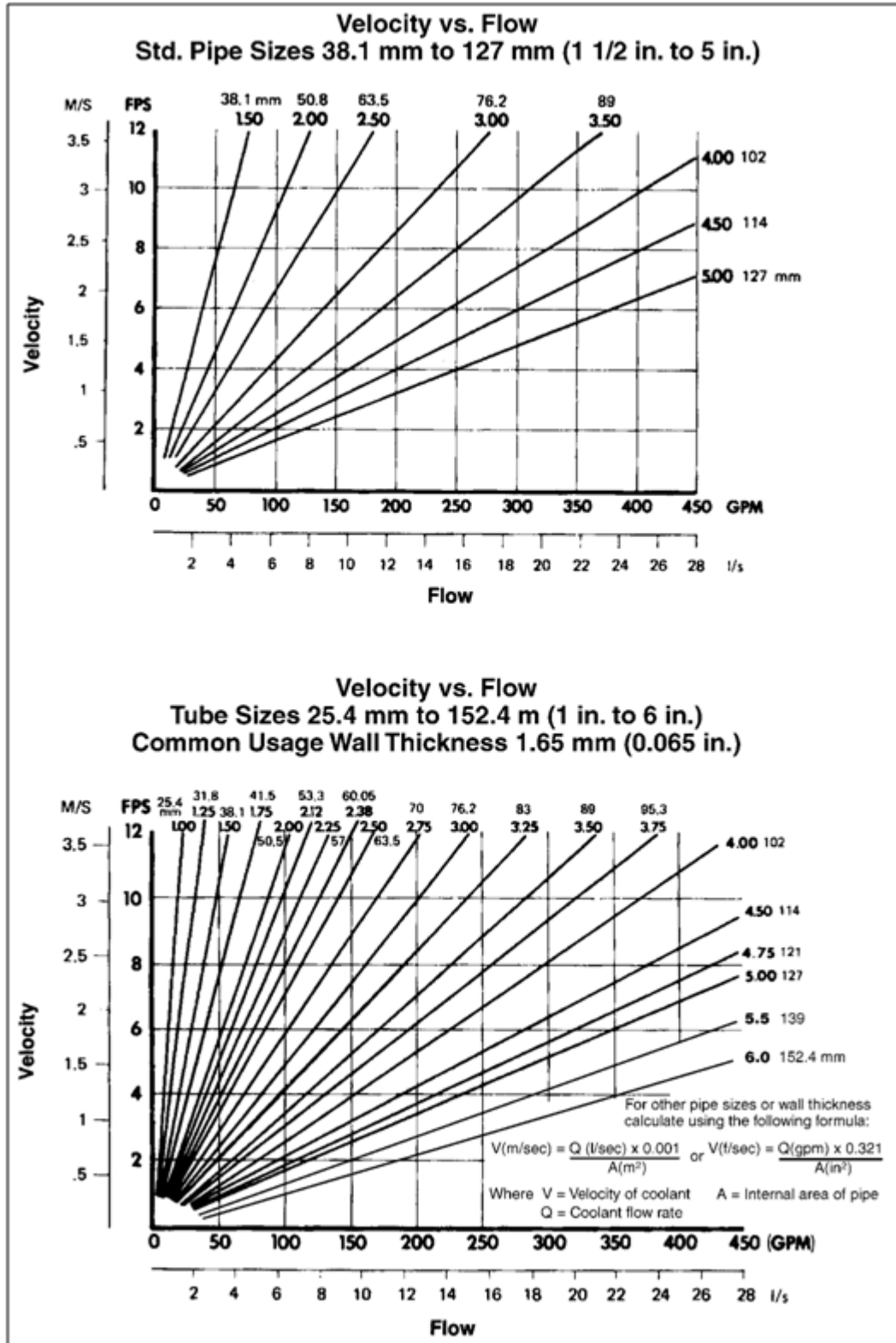

Figure 9.1 — Velocity versus flow curves for standard pipe sizes and for common tube sizes.

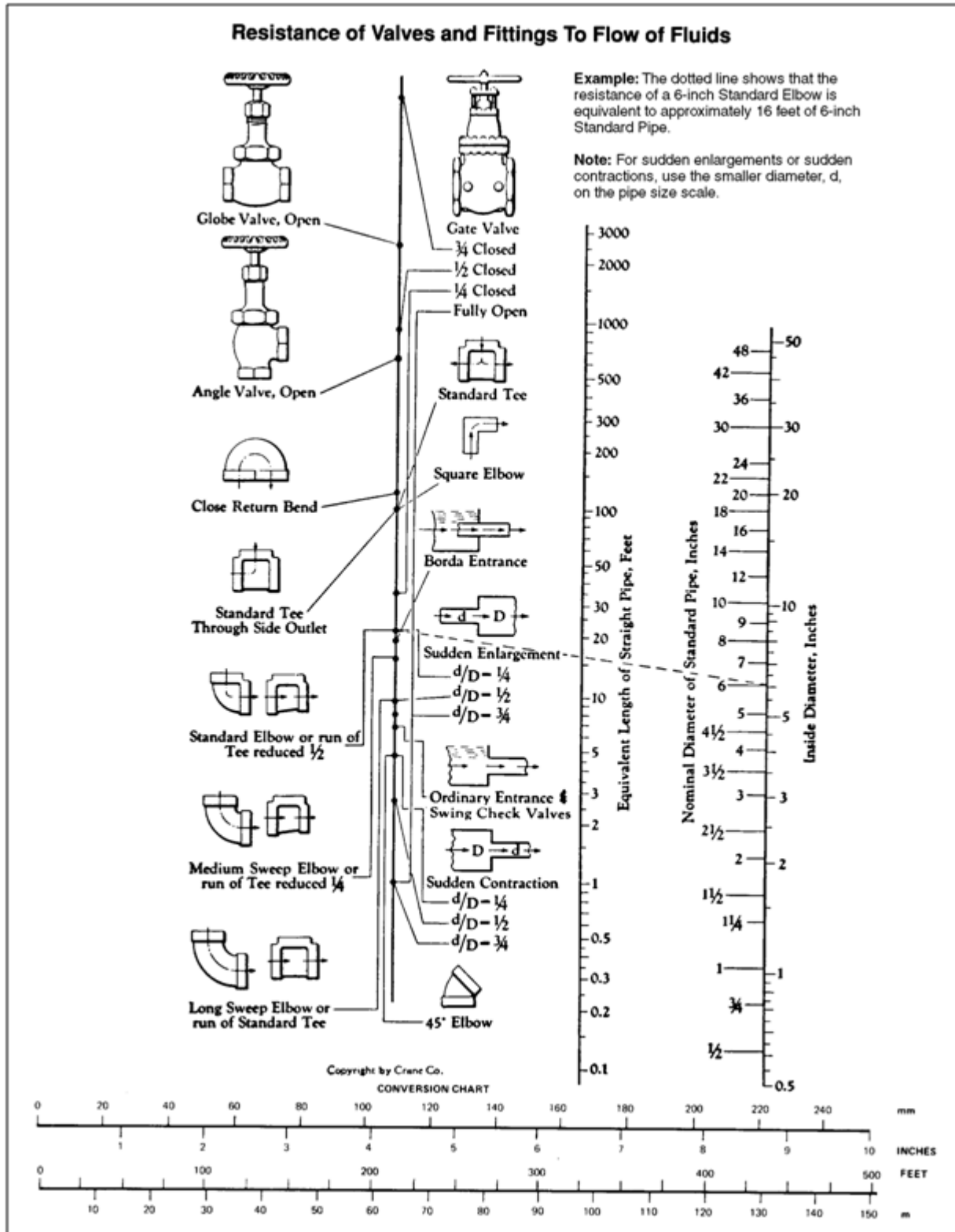

Figure 9.2 — Nomograph of valves and fittings expressed as equivalent straight length of pipe.

Head Loss in meters per 100 meters (feet per 100 feet)								
		3/4 in	1 in	1-1/4 in	1-1/2 in	2 in	2-1/2 in	3 in
gal/min	L/min	19.05 mm	25.4 mm	31.75mm	38.1 mm	50.8 mm	63.5 mm	76.2 mm
5	18.9	10.5	3.25	0.84	0.40	0.16	0.05	
10	37.9	38.0	11.7	3.05	1.43	0.50	0.17	0.07
15	56.8	80.0	25.0	6.50	3.05	1.07	0.37	0.15
20	75.7	136	42.0	11.1	5.20	1.82	0.61	0.25
		4 in						
25	94.6	101.6 mm	64.0	16.6	7.85	2.73	0.92	0.38
30	114	0.13	89.0	23.0	11.0	3.84	1.29	0.54
35	133	0.17	119	31.2	14.7	5.10	1.72	0.71
40	151	0.22	152	40.0	18.8	6.60	2.20	0.91
			5 in					
45	170	0.28	127 mm	50.0	23.2	8.20	2.76	1.16
50	189	0.34	0.11	60.0	28.4	9.90	3.32	1.38
60	227	0.47	0.16	85.0	39.6	13.9	4.65	1.92
70	265	0.63	0.21	113	53.0	18.4	6.20	2.57
75	284	0.72	0.24	129	60.0	20.9	7.05	2.93
80	303	0.81	0.27	145	68.0	23.7	7.90	3.28
				6 in				
90	341	1.00	0.34	152.4 mm	84.0	29.4	9.80	4.08
100	379	1.22	0.41	0.17	102	35.8	12.0	4.96
					7 in			
125	473	1.85	0.63	0.26	177.8 mm	54.0	17.6	7.55
150	568	2.60	0.87	0.36	0.17	76.0	25.7	10.5
						8 in		
175	662	3.44	1.16	0.48	0.22	203.2 mm	34.0	14.1
200	757	4.40	1.48	0.61	0.28	0.15	43.1	17.8
225	852	5.45	1.85	0.77	0.35	0.1	54.3	22.3
250	946	6.70	2.25	0.94	0.43	0.24	65.5	27.1
							9 in	
275	1041	7.95	2.70	1.10	0.51	0.27	228.6 mm	32.3
300	1136	9.30	3.14	1.30	0.60	0.32	0.18	38.0
325	1230	10.8	3.65	1.51	0.68	0.37	0.21	44.1
350	1325	12.4	4.19	1.70	0.77	0.43	0.24	50.5
								10 in
375	1420	14.2	4.80	1.95	0.89	0.48	0.28	254 mm
400	1514	16.0	5.40	2.20	1.01	0.55	0.31	0.19
425	1609	17.9	6.10	2.47	1.14	0.61	0.35	0.21
450	1703		6.70	2.74	1.26	0.68	0.38	0.23
475	1798		7.40	2.82	1.46	0.75	0.42	0.26
500	1893			2.90	1.54	0.82	0.46	0.28
750	2839			7.09	3.23	1.76	0.98	0.59
1000	3785				5.59	2.97	1.67	1.23
1250	4732				8.36	4.48	2.55	1.51
1500	5678					6.24	3.52	2.13
1750	6624					7.45	4.70	2.80

Figure 9.3 — Head loss for straight lengths as percent of total length (shown as water column).

9.2.2 Example of Straight Length Method of Estimating System Restriction

The sketch below (Figure 9.4) shows a proposed design for an external cooling system. The flow path at the engine outlet and return includes piping perpendicular to the page, thus there are two 90 degree elbows that are not visible in the sketch. The tables below the sketch show a summation of the straight length equivalents for the design for four different pipe diameters, followed by the conversion of the straight length approximations to an equivalent restriction value in meters or feet of water column.

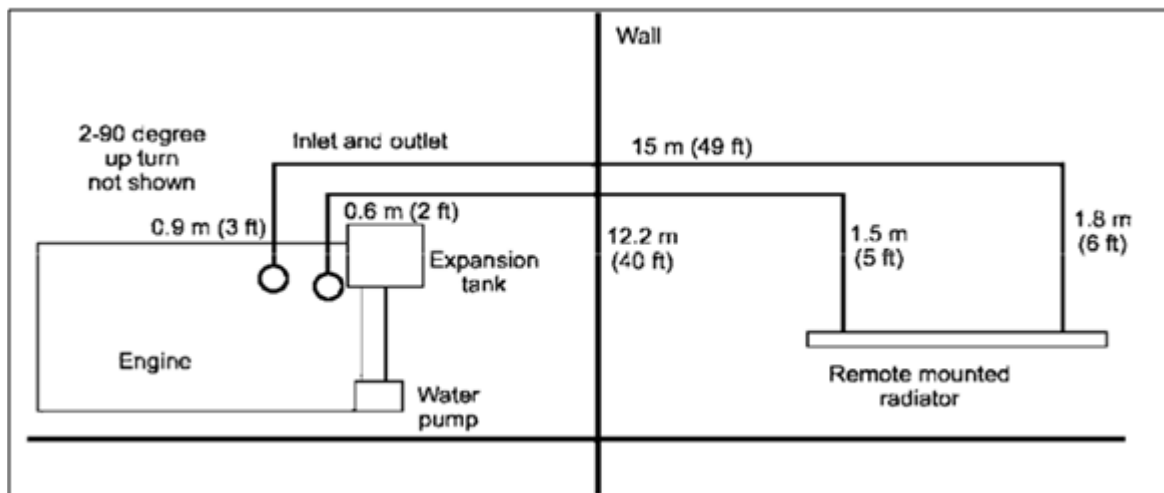

Figure 9.4 — System sketch of proposed external cooling path.

Pipe Size Inch	Straight Length m (ft)	Restriction per Elbow (Equivalent Length) m (ft)	Restriction per Valve (Equivalent Length) m (ft)	Total System (Effective Length) m (ft)
4	32 (105)	3.35 (11)	0.76 (2.5)	53.6 (176)
5	32 (105)	4.27 (14)	0.90 (3.0)	59.4 (195)
6	32 (105)	4.88 (16)	1.07 (3.5)	65.0 (214)
8	32 (105)	6.40 (21)	1.37 (4.5)	73.1 (240)

Table 9.3 — Summation of straight lengths and equivalents for the system shown above.

Pipe Size Inch	Equivalent Length m (ft)	Restriction/100 m (ft) @ 1325 L/min (350 gpm)	Total Restriction m H ₂ O (ft H ₂ O)
4	53.6 (176)	12.40	6.64 (21.8)
5	59.4 (195)	4.19	2.49 (8.17)
6	65.0 (214)	1.70	1.10 (3.60)
8	73.1 (240)	0.43	0.31 (1.03)

Table 9.4 — Summation of system restriction based on straight length estimates.

9.3 Appendix C

9.3.1 Coolant

While the quality of fuels and lubricating oils is of primary concern to engine operators, the quality of the engine coolant is just as important. With over 50% of all engine failures related to poor cooling system maintenance, proper coolant selection and maintenance are vital to successful engine service life.

The proper coolant/antifreeze will provide:

- Adequate heat transfer
- Compatibility with cooling system components, such as hoses, seals, and piping
- Protection from water pump cavitation and other cavitation erosion
- Protection from freezing and from boiling
- Protection from the build-up of corrosion, sludge, and scale

9.3.2 Accepted Coolant Components

Water is an excellent heat transfer fluid due to its low cost, wide availability, and high heat carrying capacity. However, water is also an excellent oxidizing agent and at the temperatures found in an engine's cooling system will readily form rust and scale deposits on the cooling passage inner surfaces. It is also susceptible to contamination from the oils, greases, cleaning compounds, and combustion gases in the engine, which can lead to the formation of acids that only increase the corrosive tendencies of water inside the engine.

The first step toward improving water's performance as an engine coolant is to remove any impurities found in the water from its source. Distilled or deionized water is strongly recommended, but if no source is readily available use water that meets the minimum acceptable water requirements found in other Caterpillar publications (see the references list in this guide). Types of water that are not acceptable include salt water, sea water, hard water, or softened water that has been conditioned with salt. All of these contain either dissolved salt or minerals that will render the water corrosive or prone to scale formation. In fact, water should not be used by itself, without the addition of supplemental coolant additives (SCA).

Supplemental coolant additives protect the metal surface of the cooling system by helping prevent corrosion, rust, scale, and other mineral deposits, as well as helping to control pitting/erosion of cylinder liners (due to cavitation) and foaming of the coolant. SCAs must be used in the proper concentration to be effective. Over-treatment of the water with SCAs can lead to other problems, so additional SCA should not be put in the cooling system unless testing shows additive depletion.

Two forms of glycol are widely used in engine cooling systems, ethylene glycol (EG) and propylene glycol (PG). Typically blended with water, glycols extend the temperature range for water by elevating the boiling point and lowering the freezing point. They also alter the fluid properties in a manner that lowers the likelihood of cavitation occurring in the pump and around the cylinder liners. The recommended blending ratio for glycol and water is 1:1 (50% of each in the mixture). Refer to the Operation and Maintenance Manual for each particular engine model to view any exceptions to this guideline.

Note: Aluminum radiators will require a coolant conditioner to be added when newly installed to prevent nitrite depletion and color fading when used with Cat ELC (Extended Life Coolant) or ELI (Extended Life Inhibitor for treated water applications). Nitrites are included in Cat coolants to provide cylinder liner pitting protection. Refer to Special Instruction "Instructions for Use of Cat Coolant Conditioner for Aluminum Components (REHS7296)" for more information. Do not use this coolant conditioner in conjunction with other formulated coolants; they will already contain additives.

If boiler-type coolants are used (for high-temperature or cogeneration systems), the system should be checked regularly to ensure the additives are kept at the appropriate levels. A general recommendation is every 250 hours of operation or six months; other intervals may be recommended, depending upon the specific engine application. As with SCAs, these additive must not be dosed in excess of the recommended levels to avoid causing other system issues.

9.3.3 Coolant Recommendations

Caterpillar recommends the use of its coolants, specifically formulated for superior performance in diesel and natural gas engines.

- Cat DEAC Diesel Engine Antifreeze/Coolant
- Cat ELC Extended Life Coolant
- Cat NGEC Natural Gas Engine Coolant

DEAC is an excellent conventional coolant for diesel engines. ELC offers DEAC levels of performance with extended service life for the coolant fill, water pump seals, and radiator internal passages. For gas engines Caterpillar recommends only the NGEC be used; DEAC and ELC are not recommended for use in gas engines.

9.3.4 Testing and S•O•S Coolant Analysis

Periodic testing of the coolant is important to achieving the best performance from the cooling system. Caterpillar S•O•S Coolant Analysis is a comprehensive testing service available through Cat engine dealers. The Level 1 analysis checks glycol concentration, additive levels, pH, conductivity, hardness, visual appearance, and odor. Level 2 analysis encompasses all of the Level 1 checks plus analysis to identify the source of metal corrosion, scaling, and contaminants. Detailed information on testing and S•O•S may be found in the appropriate Caterpillar engine fluids publications and through discussion with a Cat engine dealer.

9.4 Appendix D

9.4.1 Other Supplemental Worksheets

The following pages present design worksheets useful for sizing specific engine cooling system attachments.

9.4.2 Heat Exchanger Sizing Worksheet

Sheet 1 of 1

Heat Exchanger Sizing Data

Required by Heat Exchanger Supplier

Engine Jacket Water Circuit:

- | | | |
|---|-------|--------------|
| 1. Jacket water heat rejection* | _____ | kW (Btu/min) |
| 2. Jacket water flow* | _____ | L/sec (Gpm) |
| 3. Anticipated seawater maximum temperature | _____ | C° (F°) |
| 4. Seawater flow | _____ | L/sec (Gpm) |
| 5. Allowable jacket water pressure drop | _____ | m (ft) water |
| 6. Allowable seawater pressure drop | _____ | m (ft) water |

Drop

- | | | |
|--|--------------------------|-------------|
| 7. Auxiliary water source
(sea water or fresh water) | <input type="checkbox"/> | seawater |
| | <input type="checkbox"/> | fresh water |
| 8. Heat exchanger material
(admiralty or copper-nickel) | <input type="checkbox"/> | adm. metal |
| | <input type="checkbox"/> | cu-ni |

9. Shell connection size** _____

10. Tube side fouling factor*** _____

Aftercooler Water Circuit:

- | | | |
|--|-------|--------------|
| 1. Aftercooler circuit water heat rejection* | _____ | kW (Btu/min) |
| 2. Aftercooler circuit water flow* | _____ | L/s (Gpm) |
| 3. Anticipated seawater maximum temperature | _____ | C° (F°) |
| 4. Seawater flow* | _____ | L/s (Gpm) |
| 5. Allowable Aftercooler Circuit
Water Pressure Drop* | _____ | m (ft) water |
| 6. Allowable seawater pressure drop* | _____ | m (ft) water |

- | | | |
|--|--------------------------|-------------|
| 7. Auxiliary water source
(sea water or fresh water)* | <input type="checkbox"/> | seawater |
| | <input type="checkbox"/> | fresh water |
| 8. Heat exchanger material
(admiralty or copper-nickel) | <input type="checkbox"/> | adm. metal |
| | <input type="checkbox"/> | cu- ni |

9. Shell connection size** _____

10. Tube side fouling factor*** _____

* Refer to TMI (Technical Marketing Information)

** Refer to engine general dimension drawing

*** Fouling Factor, a descriptive quantity often found on heat exchanger specifications, refers to the heat exchangers ability to resist fouling. As defined in Caterpillar literature, fouling factor is the percentage of the heat transfer surface which can be fouled without losing the heat exchanger's ability to dissipate the engine's full heat load.

9.4.3 Keel Cooler (Fabricated) Sizing Worksheet

Sheet 1 of 1

Engine Jacket Water Circuit:

- | | | |
|--|--------------------------|-----------------------------------|
| 1. Jacket water heat rejection* | _____ | kW (Btu/min) |
| 2. Jacket water flow* | _____ | L/sec (Gpm) |
| 3. Vessel speed classification | <input type="checkbox"/> | 8 knots & above |
| | <input type="checkbox"/> | 3 knots |
| | <input type="checkbox"/> | 1 knot |
| | <input type="checkbox"/> | still water |
| 4. Anticipated seawater maximum temperature | _____ | C° (F°) |
| 5. Minimum cooler area required (per unit) | _____ | m ² /kW |
| | _____ | (ft ² /Btu/min) |
| 6. Minimum area required (Line 1 times Line 5) | _____ | m ² (ft ²) |

Aftercooler Water Circuit:

- | | | |
|--|--------------------------|-----------------------------------|
| 1. Aftercooler circuit heat rejection* | _____ | kW (Btu/min) |
| 2. Aftercooler circuit water flow* | _____ | L/sec (Gpm) |
| 3. Vessel speed classification | <input type="checkbox"/> | 8 knots & above |
| | <input type="checkbox"/> | 3 knots |
| | <input type="checkbox"/> | 1 knot |
| | <input type="checkbox"/> | still water |
| 4. Anticipated seawater maximum temperature | _____ | C° (F°) |
| 5. Minimum cooler area required (per unit) | _____ | m ² /kW |
| | _____ | (ft ² /Btu/min) |
| 6. Minimum area required (Line 1 times Line 5) | _____ | m ² (ft ²) |

Marine Gear Oil Cooling Circuit:

- | | | |
|--|--------------------------|-----------------------------------|
| 1. Marine gear heat rejection** | _____ | kW (Btu/min) |
| 2. Vessel speed classification | <input type="checkbox"/> | 8 knots & above |
| | <input type="checkbox"/> | 3 knots |
| | <input type="checkbox"/> | 1 knot |
| | <input type="checkbox"/> | still water |
| 3. Anticipated seawater maximum temperature | _____ | C° (F°) |
| 4. Minimum cooler area required (per unit) | _____ | m ² /kW |
| | _____ | (ft ² /Btu/min) |
| 5. Minimum Area Required (Line 1 times Line 5) | _____ | m ² (ft ²) |

* Refer to TMI (Technical Marketing Information)

** See section on Marine Gear Heat Rejection

9.4.4 Packaged Keel Cooler Sizing Worksheet

Sheet 1 of 1

Engine Jacket Water Circuit:

1. Jacket water heat rejection*
2. Jacket water flow*
3. Vessel speed classification

_____ kW (Btu/min)
_____ L/s (Gpm)
 8 knots & above
 3 knots
 1 knot
 still water
_____ °C (°F)

4. Anticipated seawater maximum temperature

Aftercooler Water Circuit:

1. Aftercooler circuit heat rejection*
2. Aftercooler circuit water flow*
3. Vessel speed classification

_____ kW (Btu/min)
_____ L/s (Gpm)
 8 knots & above
 3 knots
 1 knot
 still water
_____ °C (°F)

4. Anticipated seawater maximum temperature

*Refer to TMI (Technical Marketing Information)

9.4.5 Auxiliary Expansion Tank Sizing

Sheet 1 of 1

Engine Model _____ Rating _____ hp at _____ rpm

For Engine Jacket Water, Figure 1.25:

Auxiliary jacket water expansion tanks are not always required.

1. Allowable external volume _____ L/gal, with engine mounted tank. (This value shown in Table 1.1, Column A, on page 37.)
2. Total volume of jacket water contained in external cooling circuit (not furnished as part of engine) _____ L/gal. See Table 1.2, page 47, for volume per length of standard iron pipe.
3. Line 2 minus Line 1 _____ L/gal.
If this value is zero or less, additional tank is not required.
If this value is greater than zero, an auxiliary tank is required.
4. If required, the *minimum* volume of the auxiliary expansion tank can be determined by:
 - a. Engine volume, Table 1.1, Column B _____
 - b. External volume Line 2 _____
 - c. Total volume—
sum of line a and line b _____
 - d. Multiply line a by 0.06 _____
 - e. Multiply line b by 0.04 _____
 - f. Multiply line c by 0.01 _____
 - g. Total of lines d, e and f _____

(This is the minimum volume of the jacket water auxiliary expansion tank.)

For Separate Circuit Aftercooler, Figure 1.26:

1. Total volume of aftercooler external water _____ L/gal.
2. Multiply Line 1 by 0.02 _____ L/gal.
3. Add the cold fill volume desired in auxiliary expansion tank to Line 2.
Total of Line 2 and cold fill volume _____ L/gal.
(This is the minimum volume of the aftercooler circuit auxiliary expansion tank.)

www.cat.com/power-systems

BUILT FOR IT.™

LEBW4978-14 (6-16)

Information contained in this publication may be considered confidential. Discretion is recommended when distributing. Materials and specifications are subject to change without notice.

©2016 Caterpillar. All rights reserved. CAT, CATERPILLAR, BUILT FOR IT, their respective logos, S•O•S, DEO, "Caterpillar Yellow", the "Power Edge" trade dress as well as corporate and product identity used herein, are trademarks of Caterpillar and may not be used without permission.

