



# Technical Service Bulletin

Technical Service Bulletin: TSB120042	Released Date: 13-Feb-2012
Fuel Pump Diagnostic Tool	

## Fuel Pump Diagnostic Tool

### Warranty Statement

The information in this document has no effect on present warranty coverage or repair practices, nor does it authorize TRP or Campaign actions.

### Contents

This service parts topic announces the availability of the VP44 fuel pump diagnostic tool, Part No. 3163834.

The fuel pump diagnostic tool is for use on the ISB and QSB5.9 Series Engines. The fuel pump diagnostic tool allows the technician to check the operation of the VP44 injection pump without removing the injection pump from the engine.

Before using the fuel pump diagnostic tool, be certain that the no-start condition on the ISB is **not** due to one or a combination of the faults listed below.

If any of the conditions listed below are present, reference the troubleshooting symptom tree Engine Difficult to Start or Will Not Start in the Troubleshooting and Repair Manual, ISB Engine (Base Engine), Bulletin No. 3666193.

- Low fuel level in the tank.
- Low battery voltage.
- Air in the fuel.

The fuel pump diagnostic tool allows the user to isolate the engine fault to either the fuel pump or the harness/electronic control module (ECM). If fault codes are present, follow the fault code troubleshooting procedure in the Troubleshooting and Repair Manual, ISB Fuel System and Electronics, Bulletin No. 3666194.

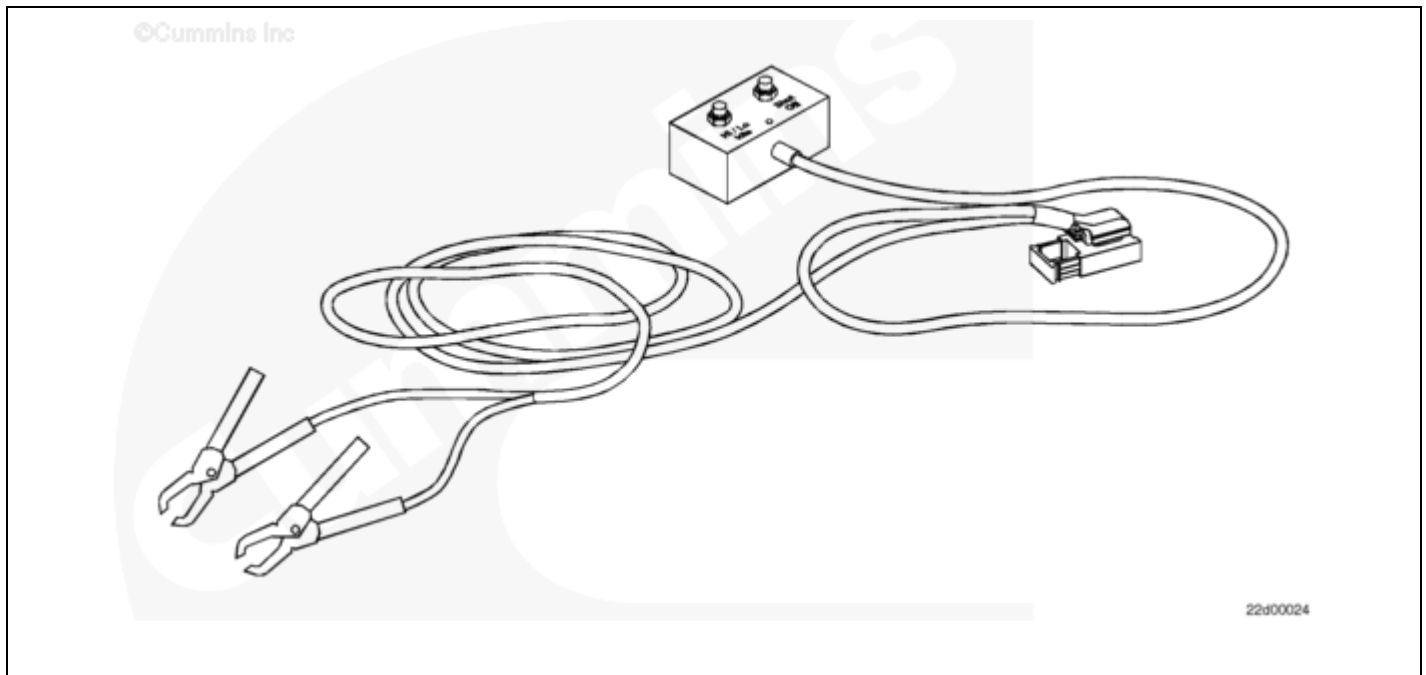

**VP44 Fuel Pump Diagnostic Tool, Part No. 3163834**

**⚠ CAUTION ⚠**

**Be certain that the clamp on the 9-pin electrical connector is completely disconnected. Failure to do so can cause damage to the 9-pin electrical connector.**

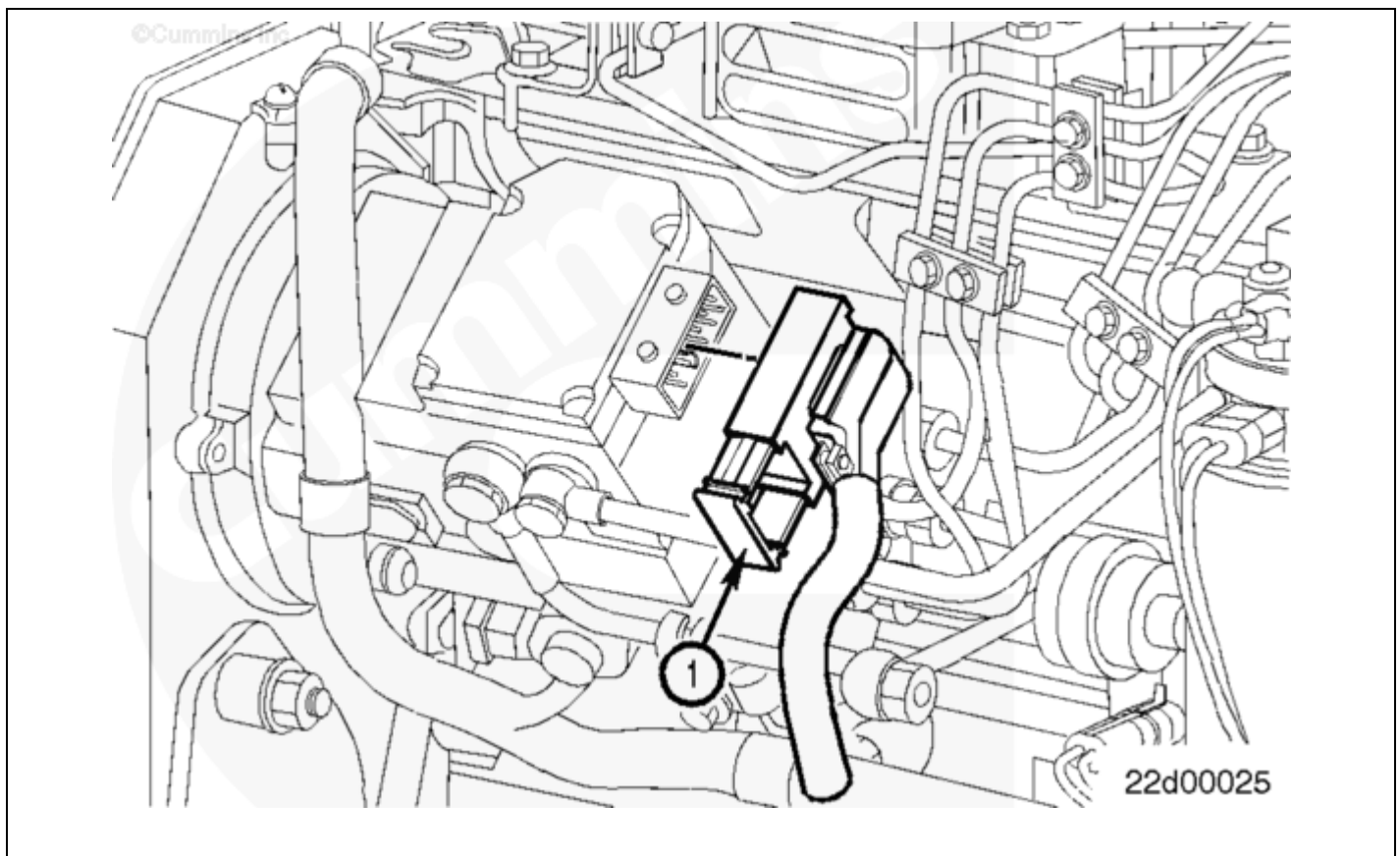

**Install**

Disengage the clamp (1) on the 9-pin electrical connector, and remove the connector from the fuel pump control module.

**Note :** Inspect the fuel pump diagnostic tool 9-pin connector for loose or expanded pins prior to installation. Regular use of the tool can loosen the pins.

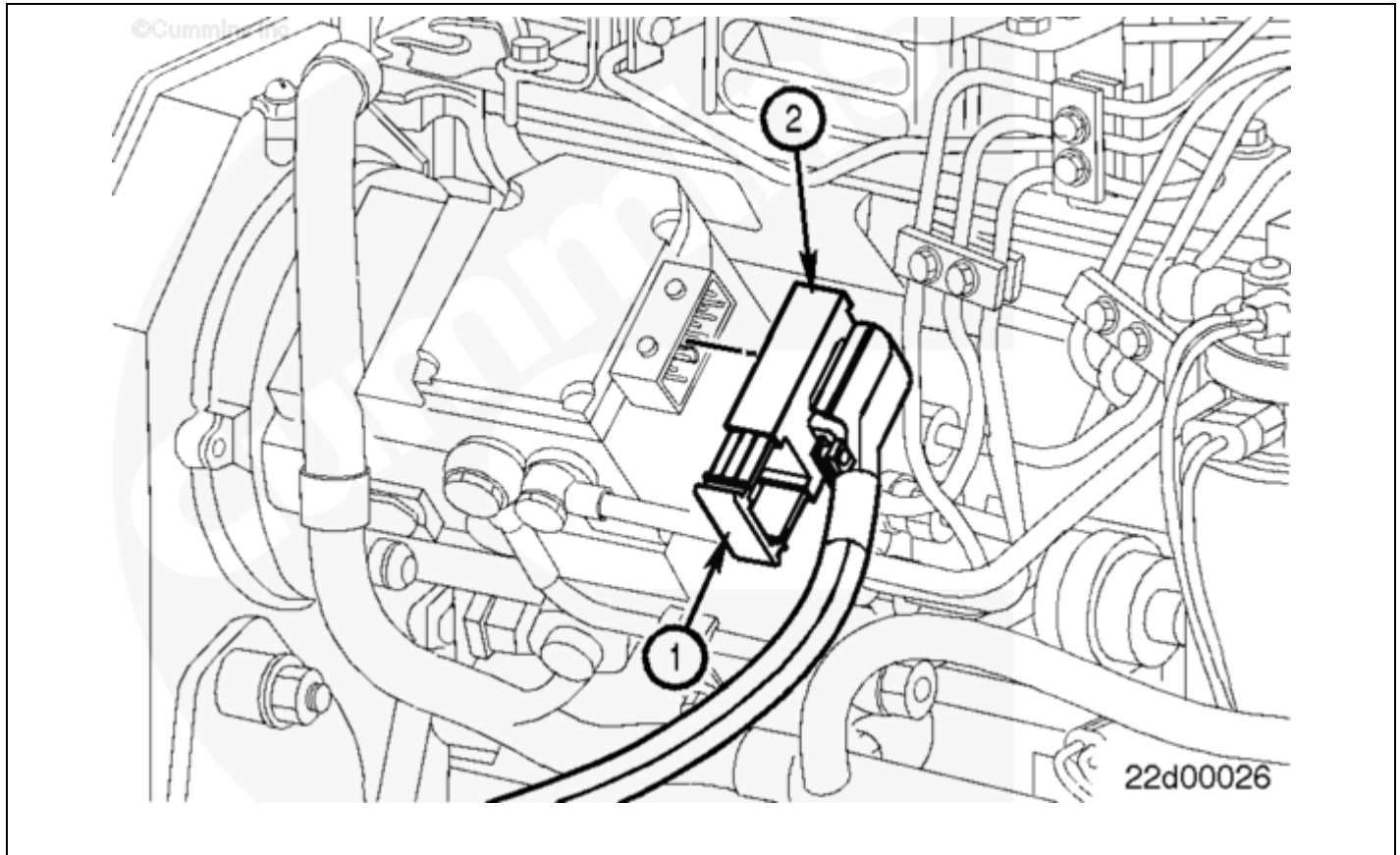

Install the fuel pump diagnostic tool 9-pin electrical connector (2) onto the back of the fuel pump control module.

Lock the clamp (1) on the fuel pump diagnostic tool 9-pin electrical connector.

**⚠ WARNING ⚠**

**Batteries can emit explosive gases. To avoid personal injury, always ventilate the compartment before servicing the batteries. To avoid arcing, remove the negative (-) battery cable first, and attach the negative (-) battery cable last.**

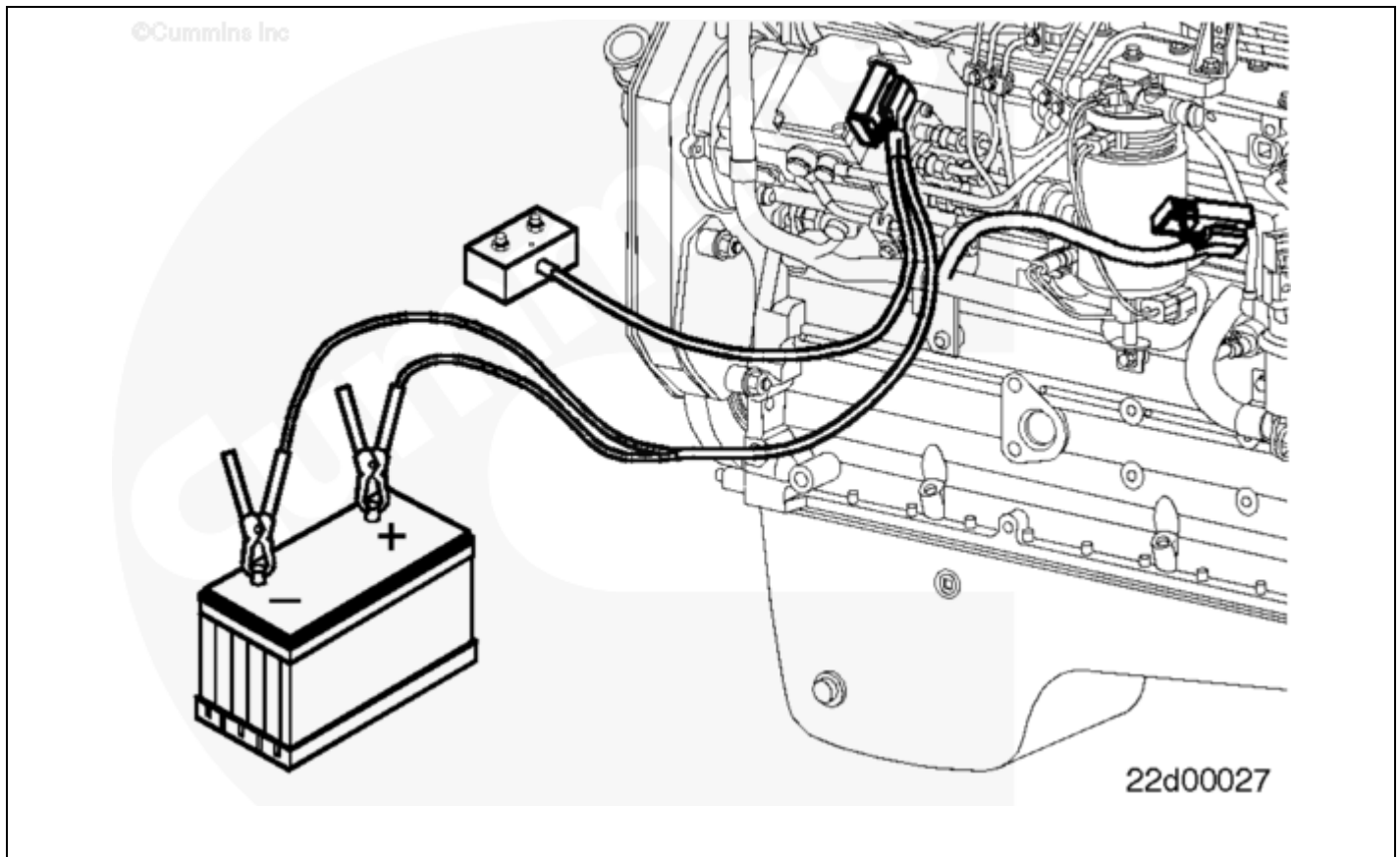

**Note :** The power-on light will illuminate after both the positive (+) and negative (-) clamps are installed.

Connect the positive (+) fuel pump diagnostic tool clamp to the positive (+) side of the battery.

Connect the negative (-) fuel pump diagnostic tool clamp to the negative (-) side of the battery.

### **Test**

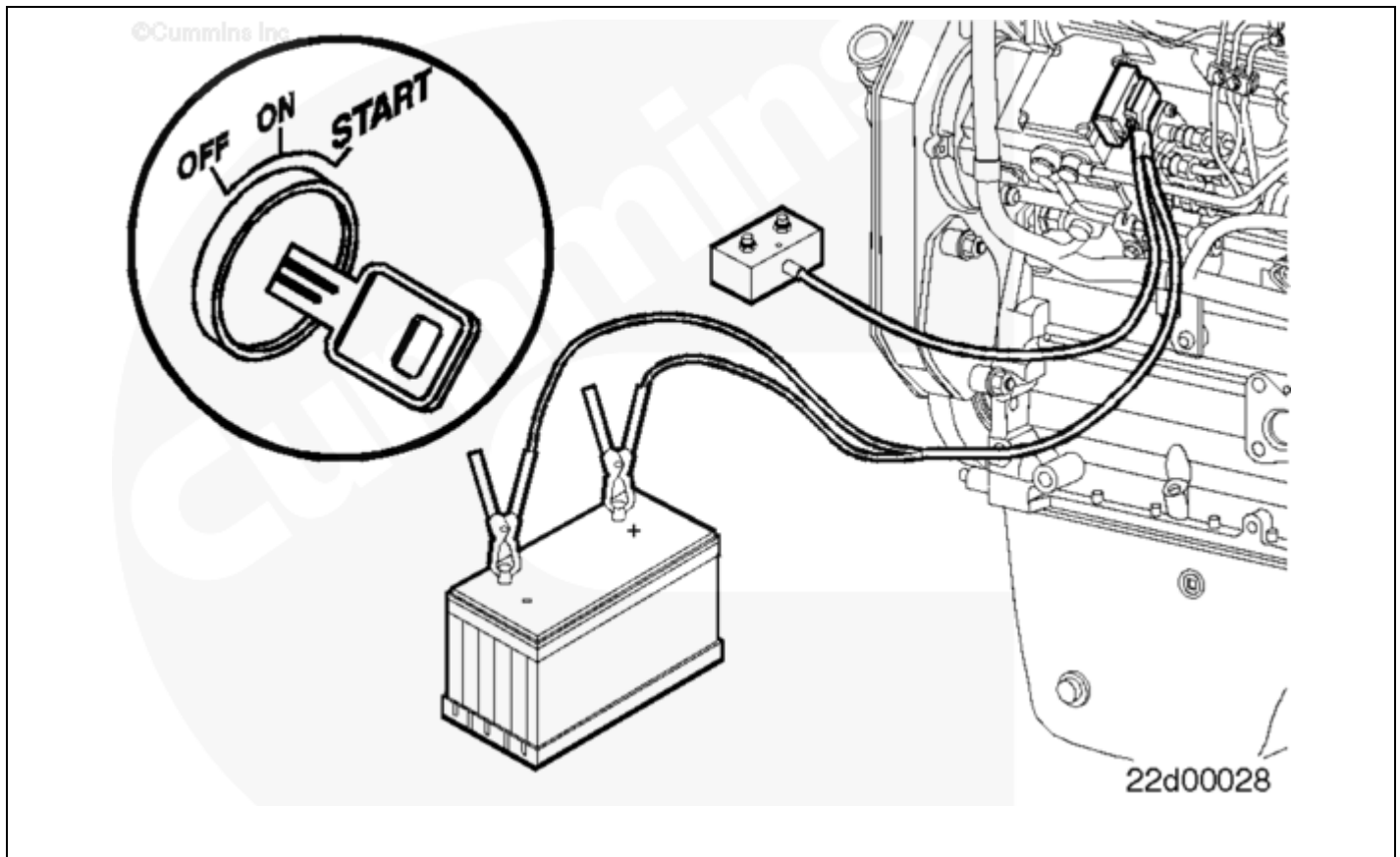

### Troubleshooting Sequence

Start the engine.

**Note :** If the engine is started while applying the voltage to the VP44 injection pump independent of the electronic control module (ECM)(with the harness connector disconnected), Fault Code 364 (no communication or invalid data transfer between the VP44 injection pump and the engine electronic control module (ECM)) will be logged. Clear the fault code from the electronic control module (ECM) after the VP44 fuel pump test has been completed.

If the engine will **not** start, replace the VP44 injection pump. Reference the Troubleshooting and Repair Manual, ISB (Base Engine), Bulletin No. 3666193, for the appropriate troubleshooting procedures.

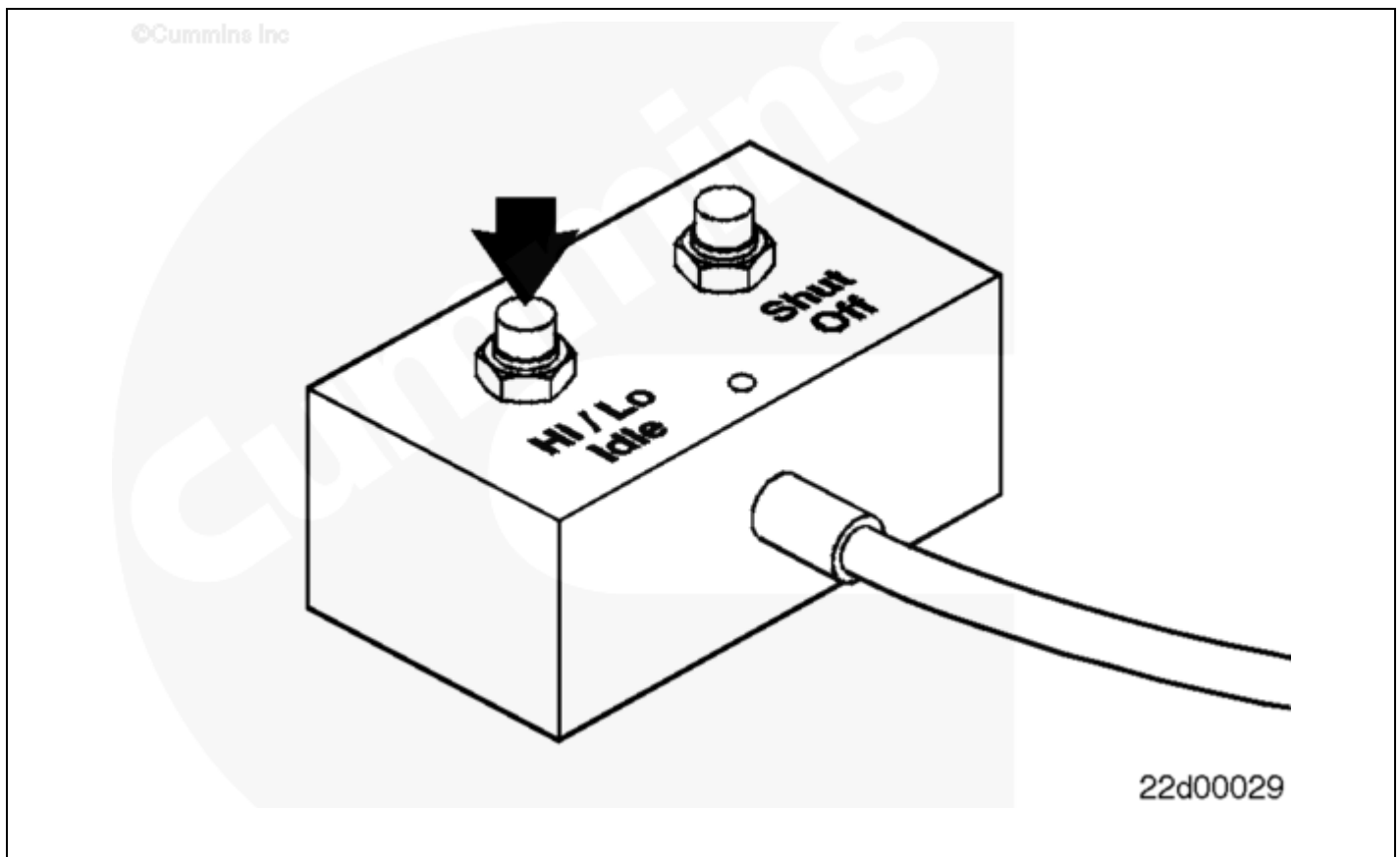

With the engine running, depress the HI/LO Idle button to check the idle speed of the engine.

- Low Idle (Lo Idle) = 700 to 875 RPM.
- Limp Home Idle (Hi Idle) = 1400 to 1500 RPM.

If there is **no** change in the engine speed or if the engine idle speed is less than or greater than the range specified above, reference the Troubleshooting and Repair Manual, ISB Engine (Base Engine), Bulletin No. 3666193, for the appropriate troubleshooting procedures.

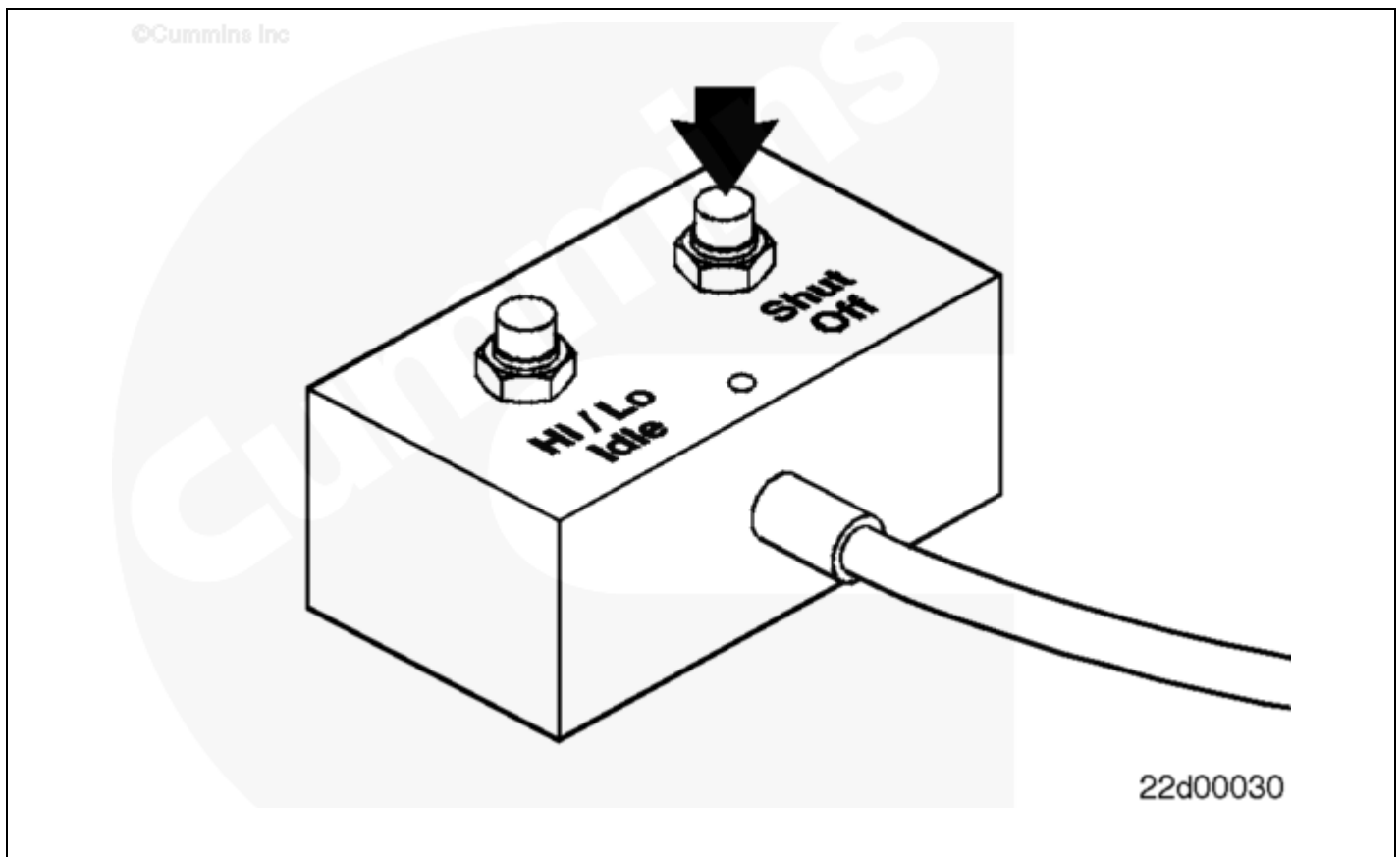

With the engine running, depress the SHUT OFF button to shut off the engine.

If the engine starts and passes the performance tests, the VP44 fuel pump is operating correctly.

Check the wiring harness or the ECM for possible failure.

### Remove

#### **⚠ WARNING ⚠**

**Batteries can emit explosive gases. To avoid personal injury, always ventilate the compartment before servicing the batteries. To avoid arcing, remove the negative (-) battery cable first, and attach the negative (-) battery cable last.**

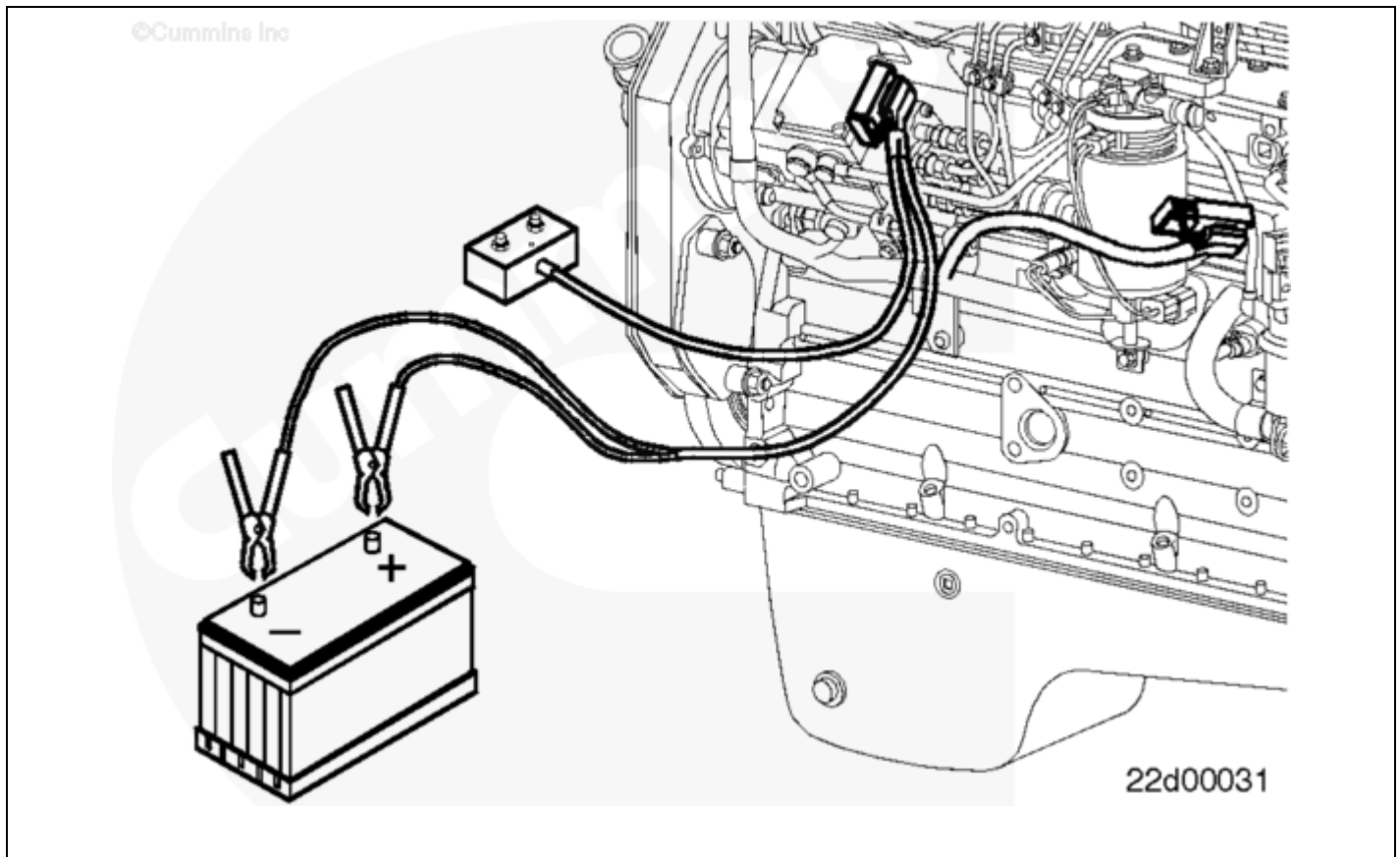

Disconnect the negative (-) fuel pump diagnostic tool clamp from the negative (-) side of the battery.

Disconnect the positive (+) fuel pump diagnostic tool clamp from the positive (+) side of the battery.

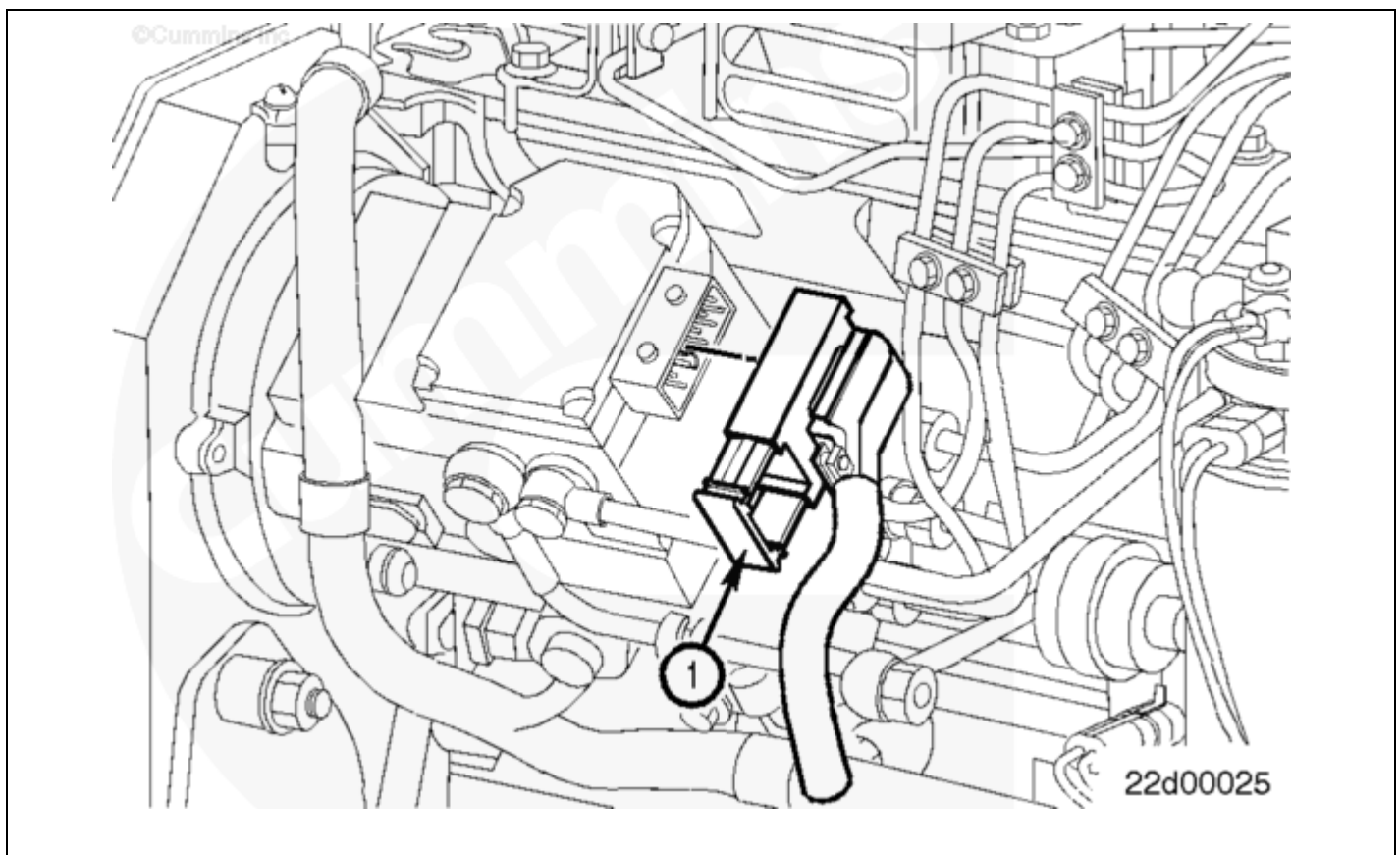

Disengage the clamp (1) on the fuel pump diagnostic tool 9-pin electrical connector.

Remove the fuel pump diagnostic tool 9-pin electrical connector.

Connect the 9-pin electrical connector to the fuel pump control module after the test has been completed.

Use the appropriate Cummins service tool to clear the false Fault Code 364 from the electronic control module.

**Note :** Reference Service Tool Instructions, Bulletin No. 3377849, for further information.

## Document History

Date	Details
2012-2-13	Module Created

---

**Last Modified: 13-Feb-2012**

---