

LAKELAND

INSTRUCTION BOOKLET

COFFEE POD MACHINE



Model: 26782

LAKELAND COFFEE POD MACHINE

Thank you for choosing the Lakeland Coffee Pod Machine.

Please take a little time to read this booklet before you use your appliance and keep it in a safe place for future reference.

The Coffee Pod Machine uses Nespresso®* and compatible coffee pod capsules to make coffee just the way you want it, in your favourite mug or espresso cup.

Here at Lakeland, our award-winning family-owned business still offers the same excellent quality, value for money and exceptional customer service as when we founded the company back in the 1960s.

Our products are hand-picked and thoroughly tested so you can be sure that everything you purchase will be a pleasure to use for many years to come.

* Brand trademarks are owned by third parties.

CONTENTS

Product features	4
Safety cautions	5-6
Using your Coffee Pod Machine for the first time.....	7-8
Instructions for use.....	9-10
Frequently asked questions	11
Button icon light sequence	11
Care and cleaning	12
Descaling.....	12-13
Technical information	14
Electrical connections	14
Recycling your electricals	14

PRODUCT FEATURES

1. Lever
2. Espresso button
3. Water tank lid
4. Water tank
5. Lungo button
6. Main unit
7. Drip tray
8. Drip plate
9. Used capsule container
10. Nozzle
11. Capsule holder

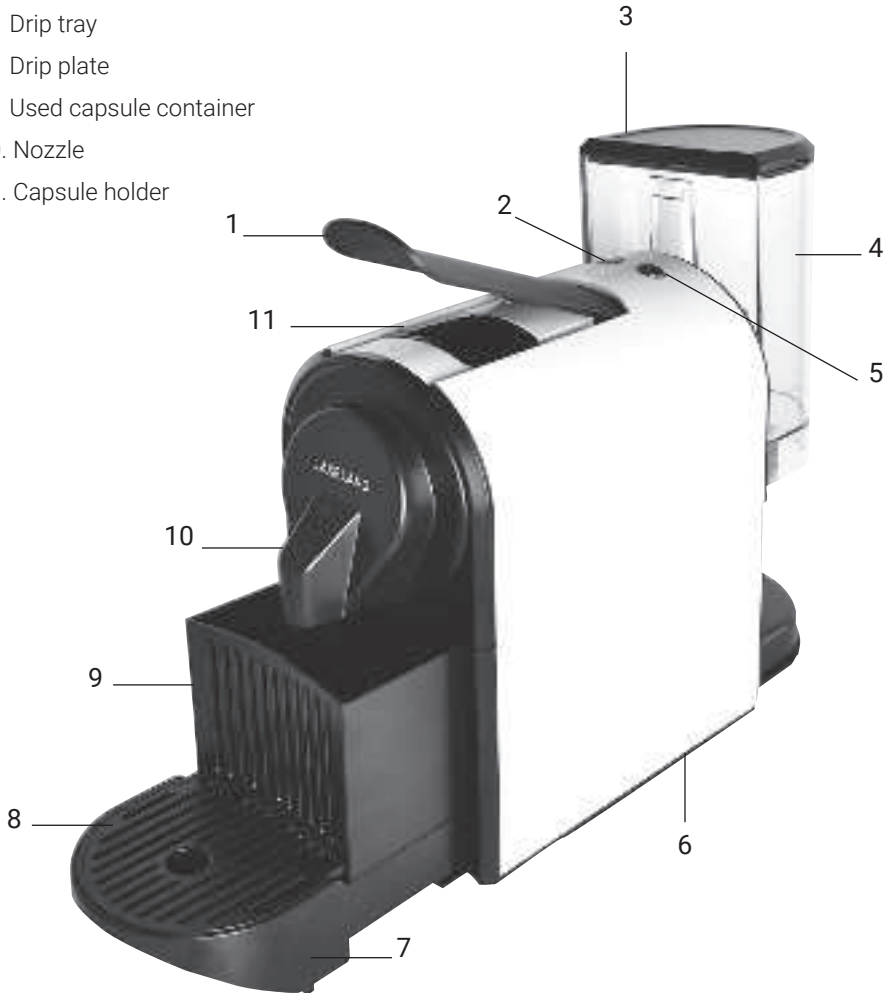

SAFETY CAUTIONS

Carefully read all the instructions before using the appliance and keep in a safe place for future reference. Always follow these safety cautions when using the appliance to avoid personal injury or damage to the appliance. This appliance should be used only as described in this instruction book.

- This appliance can be used by children aged from 8 years and above and persons with reduced physical, sensory or mental capabilities or lack of experience and knowledge if they have been given supervision or instruction concerning use of the appliance in a safe way and understand the hazards involved. Children shall not play with the appliance. Cleaning and user maintenance shall not be done by children unless they are older than 8 and supervised.
- Make sure your electricity supply matches the voltage shown on the appliance.
- Ensure all packaging materials and any promotional labels or stickers are removed from the appliance before the first use.
- Always inspect the appliance before use for noticeable signs of damage. Do not use if damaged or has been dropped. In the event of damage, or if the appliance develops a fault contact the Lakeland customer care team on 015394 88100.
- Do not use this appliance if the lead is damaged. Contact the Lakeland customer care team on 015394 88100.
- Always use the appliance on a dry, level, heat resistant surface.
- Unplug from the mains when not in use and before cleaning. To disconnect, turn the socket to "off" and remove the plug from the mains socket.
- Do not use any accessories or attachments with this appliance other than those recommended by Lakeland.
- To protect against fire, electric shock or personal injury, do not immerse cord, plug or lid in water or other liquids.
- Do not leave the lead hanging over the edge of a kitchen table or worktop. Avoid contact between the lead and hot surfaces.
- For indoor use only.
- For domestic use only.
- This appliance should be used for preparation of drinks as described within the instructions for use that accompany it.
- Always ensure that your hands are dry before removing the plug from the mains socket. Never pull the plug out of the mains socket by its lead.
- To avoid injury or possible fire, do not cover the appliance when in use.
- Do not connect this appliance to an external timer or remote control system.

- An extension cable may be used with care. The electrical rating of the cable should be at least as great as the appliance. **DO NOT** allow the cable to hang over the edge of the worktop or touch any hot surfaces.
- This appliance complies with the basic requirements of Directives 2014/30/EU (Electromagnetic Compatibility) and 2014/35/EU (Low Voltage Directive).
- **WARNING:** A cut off plug inserted into a 13amp socket is a serious safety (shock) hazard. Ensure the cut off plug is disposed of safely.
-  **CAUTION:** The plastic bags used to wrap this appliance or the packaging may be dangerous. To avoid risk of suffocation, keep these bags out of reach of babies and children. These bags are not toys.
- **DO NOT** place the appliance on or near a gas or electric oven, or any hot surfaces.
- **DO NOT** move the appliance while it is switched on.
- The water tank must be filled with water to at least the 'MIN' mark, before it is switched on. **DO NOT** fill beyond the 'MAX' mark, or the appliance may spit boiling water.
- **CAUTION:** The piercing blades are very sharp in the capsule holder. Care must be taken when filling, emptying and during cleaning.

WARNING: To avoid injury, **DO NOT** put fingers into the capsule holder.

WARNING - HOT SURFACES

- **DO NOT** open the water tank lid or reach into the water tank when the appliance is switched on. Hot steam will escape and is a scalding hazard. Ensure the water tank lid is fully closed.
- **DO NOT** place any cloths or objects over the steam vent.
- **DO NOT** open the lever during the operation.
- Never place your arm over the appliance when in use, hot steam will escape and may cause injury.
- Surfaces marked with this symbol  will be hot when the appliance is on and for some time after it is switched off.
- Allow the appliance to fully cool down before moving, cleaning or storing.



USING THE COFFEE POD MACHINE FOR THE FIRST TIME

- Unpack the Coffee Pod Machine, remove all the packaging materials.
- Before first use, wipe the main unit with a clean damp cloth.
- Wash the water tank, water tank lid, drip tray, drip plate, used capsule container in hot soapy water, rinse and dry thoroughly.
- Make sure all parts are clean and dry before assembling the product.
- Place the appliance on a dry, level heat resistant surface.

ADJUSTING THE DRIP TRAY AND DRIP PLATE

- The drip tray can be used in the down position for espresso cups and pivoted upwards for coffee mugs and glasses.
- Hold the drip tray and plate at the end and general move it upwards.

FILLING THE WATER TANK



- Before first use, the fill the water tank with fresh cold water.
 - Remove the water tank lid and fill to the MAX mark and then replace the lid.
 - The water tank can be removed from the appliance for easier filling or cleaning. Lift the whole tank straight up from the appliance.
 - To replace the removable water tank make sure the groove lip is located over the notch on the back of the appliance.
- **WARNING:** To avoid the risk of burning or scalding from hot coffee or steam **DO NOT** fill beyond the MAX mark, or the appliance may spit boiling water. Always make sure it is filled above the MIN mark.

START-UP MODE



- Plug in and switch on at the socket. The button icons will flash twice (0.5s on, 0.5s off, cycle flashing; referred to as slow flashing).
 - After about 2 seconds if everything is correct, the button icons will go off and then enter into the power saving mode.
 - If there is a problem, the button icons will turn on for 0.20s and turn off for 0.20s cycling flash (referred to as flash quickly).
 - If you press the Espresso button (small cup) and Lungo button (large cup) together, at the same time by mistake, you will have entered into a cleaning function, both the button icons will flash alternatively, continuously. Switch off and unplug the appliance at the wall for 5 minutes to reset.
- During the this mode, if there is no operation for 5 minutes, the button icons will go out at the same time, and the appliance will automatically enter the power saving mode.

POWER SAVING MODE

- When the pre-heating is finished or coffee brewing is finished and there is no operation for 5 minutes, without pressing the Espresso or Lungo buttons, the appliance will be shut down without any action and enter the power saving mode and the button icons will not be illuminated.
- In the power saving mode, press either the Espresso button (small cup) or Lungo button (large cup) to enter the start-up mode.

PRE-HEATING MODE

- In power saving mode, press either the Espresso button (small cup) or Lungo button (large cup) and you will enter into the pre-heating mode.
- The button icons will flash slowly at the same time and the heater will confirm whether heating is required according to the current temperature.
- The pre-heating temperature is set to 80°C. When the pre-heating temperature reaches the set temperature, the button icons will change from flashing to always on. The appliance will be in start-up mode after pre-heating.
- In the process of pre-heating, the water pump and solenoid valve do not work.
- Press and hold either the Espresso button (small cup) or Lungo button (large cup) for more than 4 seconds to stop pre-heating.

FIRST BREW OR COFFEE POD MACHINE NOT USED FOR A WHILE

- The first time you use the Coffee Pod Machine or if it has not been used for a long time, please **DO NOT** put the coffee pod capsule in before brewing.
- Directly brew, at least one complete the brewing cycle to remove the residual water and coffee stains inside.
- We suggest brewing an Espresso (small cup) 3 times.

INSTRUCTIONS FOR USE

- When you switch on the appliance for the first time there may be a slight burning smell. This is normal for a new product and will disappear after a few uses.
- Fill the water tank with fresh cold tap water between the MIN and MAX marks. Brew with fresh water for a better tasting coffee.
- A coffee pod capsule can only be used once, **DO NOT** reuse a spent coffee pod capsule.

INSERTING A NESPRESSO® CAPSULE OR COMPATIBLE COFFEE POD



- Lift the lever.
 - Insert the coffee pod capsule into the capsule holder, with the foil part of the capsule facing the front of the appliance.
 - The coffee pod capsule will only go in one way, never force it.
 - **CAUTION:** The piercing blades are very sharp in the capsule holder. Care must be taken when filling, emptying and during cleaning.
- Close the lever, pressing down firmly, the coffee pod capsule will locate in place.
 - When you lift the lever to insert a new coffee pod capsule it will drop into the used capsule container.

BREWING COFFEE

- If you press the Espresso button (small cup) and Lungo button (large cup) at the same time by mistake, you will have entered into a cleaning function, both the button icons will flash alternatively, continuously. Unplug the appliance at the wall for 5 minutes to reset.
- After pre-heating, the appliance will enter into start-up mode and the button icon lights will always be on.
- Put the coffee pod capsule into the Coffee Pod Machine.
- Press the function button you require, Espresso button (small cup) or Lungo button (large cup) of the corresponding coffee capacity.
- The corresponding button will flash slowly.
- When the water has heated to the pre-set temperature, the corresponding button icon will be always on and your coffee will be brewed.
- During the brewing process, if you press either button, no matter whether the coffee brewing is completed or not, the coffee brewing process will be passively terminated, the water pump and heating pipe will stop working immediately, and the solenoid valve will be powered off and reset.
- The appliance will return to start-up mode, with the two button icons illuminated and on.

- When the pre-heating is finished or coffee brewing is finished and there is no operation for 5 minutes, without pressing the Espresso or Lungo buttons, the appliance will be shut down without any action and enter the power saving mode and the button icons will not be illuminated.
- If there is no water in the coffee brewing process, please open the lever to check whether there are residual capsules and other foreign matters in the capsule holder. Please clean before using.

BREWING TIME AND CAPACITY

- The brewing time for an Espresso (small cup) is 18 seconds and capacity of 40ml, Lungo (large cup) is 36 seconds and capacity of 80ml.
- When the time reaches the set value, the water pump stops working and the button icon goes out after a 6 seconds delay.
- Then the appliance will enter into start-up mode, the two button icons will be on.

CLEANING AND PLACING OF USED CAPSULE CONTAINER

- Please clean the used capsule container on a regular basis.
- The used capsule container holds 10 coffee pod capsules.
- Hold the drip tray on either side and gently pull forward. Remove used capsule container and empty, wash in hot soapy water and dry thoroughly.
- Also wash the drip tray and drip plate at the same time in hot, soapy water and dry thoroughly.
- Place the drip plate back on top of the drip tray holder and then the used capsule container on top.
- Slide the assembled unit back into the appliance until it locates in place.

FREQUENTLY ASKED QUESTIONS

Question: Why is the coffee not brewing or the Coffee Pod Machine not turning on?

Answer: The removable water tank may be empty or the appliance is not plugged in.

Check the removable water tank is filled and the appliance is plugged in.

The thermostat inside the appliance may need to cool down completely before you can make another coffee. This will take around 5 minutes.

Question: Why is the coffee maker taking a long time to brew?

Answer: The coffee maker may need cleaning or descaling.

See 'Care and Cleaning'.

BUTTON ICON LIGHT SEQUENCE

MODE	BUTTON ICON LIGHT SEQUENCE
Plug in the power supply, then entry power saving mode	Espresso and Lungo button icons flash twice together and then turn off
Press a button to Pre-heat (initial use)	Espresso and Lungo button icons flash alternatively
Heating before brewing	Espresso or Lungo button icons flash slowly
Making coffee (Brewing coffee)	Espresso or Lungo button icons are always on
Water shortage in the water tank at the time of brewing coffee	Espresso or Lungo button icons flash quickly
Brewing finished or standby	Espresso and Lungo button icons are always on
The button icon lights do not work	Check that the appliance is plugged in and turned on at the wall socket.
NTC fault error	Espresso and Lungo button icons flash quickly. The appliance will stop working. Contact Lakeland customer services.

CARE AND CLEANING

- Switch off and unplug the appliance from the socket before cleaning.
- Always allow the appliance to cool down completely before cleaning.
- Clean thoroughly before using for the first time and after every use.
- Check the parts for wear or damage after every few uses.
- Do not use abrasive cleaners or steel wool.
- Never immerse the main unit in water or any other liquid. To clean the outer surfaces, wipe with a clean damp cloth and dry thoroughly before storing.
- **CAUTION:** The piercing blades are very sharp in the capsule holder. Care must be taken when handling, emptying and during cleaning.

WARNING: To avoid injury, **DO NOT** put fingers into the capsule holder.

- Wash all removable parts in hot soapy water, rinse and dry thoroughly before reusing or storing.
- Rinse the water tank once a day.
- If the coffee maker is not going to be used for a period of time, empty the water tank completely.
- Store the Coffee Pod Machine with the power cable loosely coiled. Never wrap it tightly around the product.

DESCALING

We recommend cleaning the water tank once a month, or more frequently in hardwater areas.

- **DO NOT** use capsules when performing descaling.
- Turn off the power at the wall socket and unplug.
- Mix 500ml of cold water and 100ml of white wine vinegar and pour into the water tank.
- The total capacity should not be less than 600ml and not exceed the MAX mark of 700ml.
- Fold the drip plate and drip tray up and place a 700ml container under the nozzle.
- Plug in the socket, press and hold the Lungo button (large cup) whilst then turn on the power supply at the switch, until the two button icons flash alternately, twice a second and then release the Lungo button (large cup) to enter the descaling mode.

DESCALING STEPS

- After entering the descaling mode, the two button icons should be flashing alternately twice a second.
- Make sure you have 700ml container under the nozzle.
- Press either the Espresso button (small cup) or Lungo button (large cup).
- The appliance will start to run.
- After about 1 minute 50 seconds, it will stop running immediately.
- Empty your measuring jug down the sink.
- **NOTE:** The appliance is still in descaling mode at this time.
- Make sure you have replaced your measuring jug under the nozzle.
- After descaling, empty the water tank and add about 600ml fresh tap water into the water tank, not to exceed the MAX mark, to clean the appliance.
- Press either the Espresso button (small cup) or Lungo button (large cup) to clean the appliance.
- The appliance will start to run.
- After 1 minute 50 seconds of descaling time, it will stop running and the appliance enters the start-up mode.

TWO WAYS TO STOP DESCALING

- Press either the Espresso button (small cup) or Lungo button (large cup) for more than 5 seconds to stop descaling.
- If necessary, press again to restart descaling; otherwise, please turn off the power supply and unplug at the socket to exit the descaling mode.
- You can also turn off the power supply and unplug at the socket to exit the descaling mode.
- If descaling again, you need to re-enter the descaling mode following the instructions above.

NOTE: Never refill the water reservoir with the used descaling solution because it is no longer active.

WARNING: Never interrupt the descaling process. Malfunctions caused by scale deposited inside the appliance are not covered by the guarantee if the descaling process is not carried out properly.

TECHNICAL INFORMATION

- Power: 1400W.
- Voltage: 220-240V.
- Frequency: 50/60Hz.
- Flex length approx. 90cm (35½").
- Product weight: 2.8kg.

ELECTRICAL CONNECTIONS

THIS APPLIANCE MUST BE EARTHED

The appliance is fitted with a fused three-pin plug to BS1363 which is suitable for use in all homes fitted with sockets to current specifications.

CHANGING THE 10 AMP FUSE

Use a 10 amp BS1362 fuse. Only BSI or ASTA approved fuses should be used. If you are unsure which plug or fuse to use, always refer to a qualified electrician.

Note: After replacing or changing a fuse on a moulded plug which has a fuse cover, the cover must be refitted to the plug; the appliance must not be used without a fuse cover. If lost, replacement fuse covers can be obtained from an electrical shop. This appliance complies with the following EU Directives: 2014/35/EU (Low Voltage Directive) and 2014/30/EU (EMC Directive).



RECYCLING YOUR ELECTRICALS

Along with many other high street retailers, Lakeland has joined a scheme whereby customers can take their unwanted electrical products to recycling points set up around the country.

Visit www.recycle-more.co.uk to find your nearest recycling point.



Lakeland
Alexandra Buildings, Windermere, Cumbria, UK LA23 1BQ
Tel: +44(0)15394 88100 lakeland.co.uk