

User Guide

MGP261 Multigas Probe for Methane, Carbon
Dioxide, and Humidity Measurement

MGP261

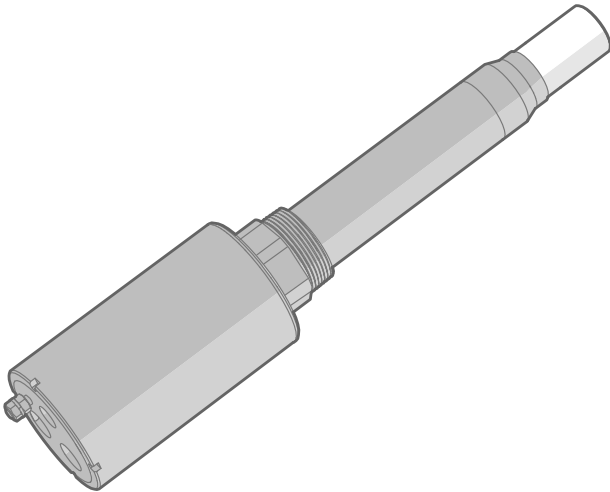

VAISALA

PUBLISHED BY

Vaisala Oyj
Vanha Nurmijärventie 21, FI-01670 Vantaa, Finland
P.O. Box 26, FI-00421 Helsinki, Finland
+358 9 8949 1

Visit our Internet pages at www.vaisala.com.

© Vaisala Oyj 2019

No part of this document may be reproduced, published or publicly displayed in any form or by any means, electronic or mechanical (including photocopying), nor may its contents be modified, translated, adapted, sold or disclosed to a third party without prior written permission of the copyright holder. Translated documents and translated portions of multilingual documents are based on the original English versions. In ambiguous cases, the English versions are applicable, not the translations.

The contents of this document are subject to change without prior notice.

Local rules and regulations may vary and they shall take precedence over the information contained in this document. Vaisala makes no representations on this document's compliance with the local

rules and regulations applicable at any given time, and hereby disclaims any and all responsibilities related thereto.

This document does not create any legally binding obligations for Vaisala towards customers or end users. All legally binding obligations and agreements are included exclusively in the applicable supply contract or the General Conditions of Sale and General Conditions of Service of Vaisala.

This product contains software developed by Vaisala or third parties. Use of the software is governed by license terms and conditions included in the applicable supply contract or, in the absence of separate license terms and conditions, by the General License Conditions of Vaisala Group.

Table of Contents

1.	About This Document	7
1.1	Version Information.....	7
1.2	Related Manuals.....	7
1.3	Documentation Conventions.....	7
1.4	Trademarks.....	8
2.	Product Overview	9
2.1	Introduction to MGP261.....	9
2.2	Basic Features and Options.....	9
2.2.1	Hazardous Area Safety.....	9
2.2.2	Measurement Parameters.....	10
2.2.3	Wet Basis and Dry Basis Measurement Output.....	10
2.2.4	Installation Type.....	11
2.2.5	Process Flow Range and Installation Type.....	11
2.2.6	Connectivity to Vaisala Insight Software.....	11
2.3	Probe Parts.....	13
2.3.1	Cable Gland Options and Lead-Throughs.....	14
2.4	Measurement Principle.....	15
2.5	Using MGP261 in Hazardous Locations.....	17
2.5.1	Guidelines for Safe Use in Hazardous Conditions.....	17
3.	Installation	20
3.1	Overview.....	20
3.1.1	Process Flow Range and Installation Type.....	20
3.1.2	NPT 1.5" Thread Test Plug 257525SP.....	21
3.1.3	Installation Preparations.....	21
3.1.4	Installation Option: Ball Valve Installation.....	22
3.1.5	Installation Option: Flow-Through Adapter Installation.....	23
3.1.6	MGP261 Dimensions.....	24
3.1.7	Recommended Installation Position on Pipeline.....	24
3.1.8	Gas Safety During Installation.....	25
3.2	Preparing Probe for Installation.....	26
3.3	Inserting Probe into Process and Opening Connection Box.....	27
3.4	Wiring.....	28
3.4.1	Wiring Diagram.....	29
3.5	Finalizing Installation.....	30
3.6	Attaching Flow-Through Adapter to MGP261.....	31
3.7	Installation Type Configuration in Insight.....	33
4.	Operating with Insight Software	34
4.1	Vaisala Insight Software.....	34
4.1.1	Basic and Advanced User Modes.....	34
4.2	Connecting to Insight Software.....	35
4.2.1	Installing the Driver for the USB Service Cable.....	36
4.3	Insight Main View.....	37

5.	Modbus	38
5.1	Configuring Modbus Communication Settings with Insight.....	39
6.	Analog Output Configuration	40
6.1	Overview.....	40
6.2	Configuring Analog Outputs with Modbus.....	40
6.3	Configuring Analog Outputs with Insight.....	40
6.4	Changing Units in Insight.....	41
6.5	Wet Basis and Dry Basis Measurement Parameters.....	42
7.	Environmental Compensation	43
7.1	Overview.....	43
7.1.1	Temperature Compensation.....	43
7.1.2	Pressure Compensation.....	43
7.1.3	Compensation Mode During Calibration.....	44
7.2	Configuring Environmental Compensations with Modbus.....	44
7.3	Configuring Environmental Compensations with Insight.....	44
7.3.1	Configuring Setpoint Values for Compensations with Insight.....	46
7.3.2	Using Probe Measurement as Temperature Compensation.....	46
7.3.3	Using Compensation Received from External Temperature or Pressure Sensor.....	46
7.3.4	Configuring Input from External Analog Pressure or Temperature Sensor.....	47
8.	Calibration	49
8.1	Calibration Overview.....	49
8.1.1	Compensation Mode During Calibration.....	50
8.1.2	Flow-Through Adapter.....	50
8.2	Calibration and Adjustment with Insight PC Software.....	52
8.2.1	Example: 2-Point Adjustment with Zero Point Adjustment.....	53
8.2.2	Zero Point Adjustment.....	53
8.2.3	Calibrating and Adjusting Methane (CH ₄) Measurement.....	54
8.2.4	Calibrating and Adjusting Carbon Dioxide (CO ₂) Measurement.....	55
8.2.5	Calibrating and Adjusting Temperature Measurement.....	56
9.	Maintenance	58
9.1	Filter Change.....	58
9.2	Removing Probe from Process.....	59
9.3	Cleaning the Probe.....	60
9.4	Sending Probe to Vaisala.....	61
10.	Technical Data	62
10.1	Specifications.....	62
10.2	Wetted Parts Material Information.....	65
10.3	MGP261 Dimensions.....	66
10.4	Flow-Through Adapter Dimensions.....	67

Appendix A:	68
A.1 Modbus Registers.....	68
A.1.1 Measurement Data.....	68
A.1.2 Configuration Registers.....	70
A.1.3 Status Registers.....	80
A.1.4 Device Identification Objects.....	83
Warranty	85
Technical Support	85
Recycling	85

List of Figures

Figure 1	Output Parameter Selections in Vaisala Insight PC Software.....	10
Figure 2	MGP261 Probe Parts (Closed and Opened View).....	13
Figure 3	Cable Gland Options and Lead-Throughs	14
Figure 4	Probe Cuvette with Mirror and Sensor Chips.....	15
Figure 5	Measurement in the Measurement Cuvette.....	16
Figure 6	MGP261 Probe Ga/Gb Division.....	17
Figure 7	NPT 1.5" Thread Test Plug.....	21
Figure 8	MGP261 Installation Example with Wiring Routes and Recommended Orientation and Depth.....	22
Figure 9	MGP261 in Flow-Through Adapter 258877.....	23
Figure 10	MGP261 Dimensions in Millimeters and Inches.....	24
Figure 11	Recommended MGP261 Installation Position on Pipeline.....	24
Figure 12	MGP261 Screw Terminal Markings and Cable Routes.....	28
Figure 13	MGP261 Wiring Diagram.....	29
Figure 14	Installation Type Selection in Insight.....	33
Figure 15	Connecting Probe to Insight.....	35
Figure 16	Insight Main Menu and Settings.....	37
Figure 17	Modbus Communication Settings in Insight PC Software.....	39
Figure 18	Analog Output Configuration Options in Insight.....	40
Figure 19	Unit Selection in Insight.....	41
Figure 20	Output Parameter Selections in Vaisala Insight PC Software.....	42
Figure 21	Measurement Menu View in Insight PC Software	45
Figure 22	Analog Input 1 Configuration Menu in Insight.....	47
Figure 23	Flow-Through Adapter 258877.....	50
Figure 24	Calibration Menu View in Insight PC Software.....	52
Figure 25	Zero Point Adjustment Tab.....	54
Figure 26	Temperature Adjustment View in Insight.....	56
Figure 27	Replacing Filter.....	58
Figure 28	MGP261 Dimensions in Millimeters and Inches.....	66
Figure 29	Flow-Through Adapter Dimensions with MGP261 Probe.....	67
Figure 30	Flow-Through Adapter Mounting Plate Dimensions.....	67

List of Tables

Table 1	Document versions.....	7
Table 2	Related Manuals.....	7
Table 3	MGP261 Measurement Parameters.....	10
Table 4	Screw Terminal Wiring Requirements.....	18
Table 5	Intrinsic Safe IIB Output Parameters.....	18
Table 6	Default Modbus Serial Communication Settings.....	38
Table 7	Measurement Performance.....	62
Table 8	Operating Environment.....	63
Table 9	Compliance.....	63
Table 10	Inputs and Outputs.....	63
Table 11	Mechanical Specification.....	64
Table 12	Options and Accessories.....	64
Table 13	Modbus Measurement Data Registers (Read-Only).....	68
Table 14	Modbus Configuration Data Registers (Writable).....	70
Table 15	Modbus Status Data Registers (Read-Only).....	80
Table 16	Error Codes in Register 0200 _{hex} (Status Code Low).....	81
Table 17	Error Codes in Register 0202 _{hex} (Status Code High).....	82
Table 18	Device Identification Objects.....	83

1. About This Document

1.1 Version Information

Table 1 Document versions

Document Code	Date	Description
M212273EN-A	August 2019	This manual. First version of the document.

1.2 Related Manuals

Table 2 Related Manuals

Document Code	Description
M212238EN	MGP261 Multilingual Installation and Safety Guide (languages: English, German, French, Dutch, Spanish, Portuguese, Italian, Hungarian, Czech, Polish, Finnish, Estonian, Swedish, Norwegian, Danish)
M212291EN	USB Service Cable 257295 Quick Guide
M212283EN	Flow-Through Adapter 258877 Quick Guide

1.3 Documentation Conventions



WARNING! Warning alerts you to a serious hazard. If you do not read and follow instructions carefully at this point, there is a risk of injury or even death.



CAUTION! Caution warns you of a potential hazard. If you do not read and follow instructions carefully at this point, the product could be damaged or important data could be lost.



Note highlights important information on using the product.

1.4 Trademarks

Vaisala® and CARBOCAP® are registered trademarks of Vaisala Oyj.

All other product or company names that may be mentioned in this publication are trade names, trademarks, or registered trademarks of their respective owners.

2. Product Overview

2.1 Introduction to MGP261

Vaisala CARBOCAP® MGP261 Multigas Probe for Methane, Carbon Dioxide, and Humidity Measurement is a compact and durable in situ probe for methane (CH₄), carbon dioxide (CO₂), and moisture (H₂O vapor) measurements in demanding biogas processing conditions. MGP261 probes are Ex certified for use in Ex Zone 0 (parts inserted into process) and Ex Zone 1 (parts outside the process).

MGP261 can be installed directly into raw process gas, removing the need for sample treatment. Application areas include anaerobic digestion of industrial and municipal waste and sludge from waste water treatment, landfill gas monitoring, activated carbon filter monitoring in biogas treatment process, and CHP engine feed gas monitoring.

The proprietary infrared technology of MGP261 provides superior stability and repeatability. Thanks to condensation elimination through probe heating and corrosion-resistant steel and plastic materials, the IP66-rated instrument is highly robust and durable.

MGP261 measurement output options include 3 analog current output channels (4 ... 20 mA) and Modbus RTU over RS-485. The probe also provides a 4 ... 20 mA Ex ia input for connecting an optional external pressure or temperature sensor.

For easy-to-use access to configuration, diagnostics, and calibration and adjustment functionalities, MGP261 can be connected to Vaisala Insight PC software with a USB cable accessory.

2.2 Basic Features and Options

- Available measurement parameters: methane (CH₄), carbon dioxide (CO₂), and moisture (H₂O vapor)
- Ex classification: **Ex II 1/2 (1) G Ex eb mb [ia] IIB T3 Ga/Gb -40 °C ≤ Tamb ≤ +60 °C**
- Operating pressure: -500 ... +500 mbar
- 3 analog outputs (4 ... 20 mA, scalable, isolated)
- Digital output: Modbus RTU over RS-485
- Optional external temperature or pressure sensor input (4 ... 20 mA, Ex ia)
- Power supply input: 18 ... 30 VDC
- Direct installation into process: for pipeline ports with 1.5" female NPT thread
- Compatible with Vaisala Insight PC software

2.2.1 Hazardous Area Safety



CAUTION! Do not install or use MGP261 in a hazardous area before reviewing the safety information in [Using MGP261 in Hazardous Locations \(page 17\)](#).

2.2.2 Measurement Parameters

Table 3 (page 10) shows the units and ranges of the MGP261 measurement parameters. For further information on the measurement parameters, see [Specifications \(page 62\)](#).

Table 3 MGP261 Measurement Parameters

Parameter	Unit	Measurement Range
Methane (CH ₄)	Volume-%	0 ... 100 vol-%
Carbon Dioxide (CO ₂)	Volume-%	0 ... 100 vol-%
Water Vapor (H ₂ O)	<ul style="list-style-type: none"> Volume-% Dew point temperature Dew point and frost point temperature 	<ul style="list-style-type: none"> 0 ... 100 vol-% -10 ... +60 °C (14 ... +140 °F)

2.2.3 Wet Basis and Dry Basis Measurement Output

MGP261 methane, carbon dioxide, and water vapor measurements can be shown either as wet basis or dry basis values. The wet basis / dry basis measurement output selection is made when ordering the probe, and can be configured with Vaisala Insight PC software or Modbus.

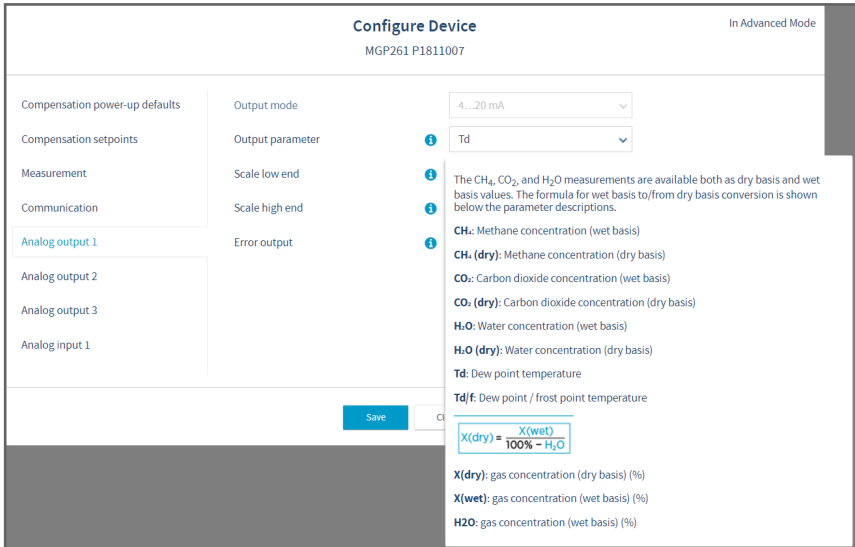

Figure 1 Output Parameter Selections in Vaisala Insight PC Software

More Information

- [Configuring Analog Outputs with Insight \(page 40\)](#)

2.2.4 Installation Type

MGP261 can be installed either directly into the process (for example, through a flange or ball valve in the actual process pipeline), or using a flow-through adapter (for example, in a sampling line installation or when performing a field calibration).

MGP261 uses different internal calculation models depending on the installation type and gas flow rate. For this reason, the type of the installation must be set correctly in MGP261 settings. You can view and change the installation type configuration with Vaisala Insight PC software: for instructions, see [Installation Type Configuration in Insight \(page 33\)](#).



CAUTION! Always ensure that the installation type configuration is set correctly in Insight when changing from one installation type to another, so that the calculation model in use matches the installation environment and measurement accuracy is not affected.

2.2.5 Process Flow Range and Installation Type

A process flow range of 2 ... 20 m/s is suitable for the in situ installation calculation model. When operating the probe in a low flow environment (0 ... 2 m/s) or using the flow-through adapter, use the flow-through calculation model. To set the correct calculation model for the flow range, choose the installation type in the Vaisala Insight PC software.

Process Flow Range	Installation Type Selection in Insight PC Software
2 ... 20 m/s	Directly in process
0 ... 2 m/s or with flow-through adapter	Flow-through adapter

More Information

- [Installation Option: Ball Valve Installation \(page 22\)](#)
- [Installation Option: Flow-Through Adapter Installation \(page 23\)](#)
- [Installation Type Configuration in Insight \(page 33\)](#)
- [Connecting to Insight Software \(page 35\)](#)
- [Specifications \(page 62\)](#)

2.2.6 Connectivity to Vaisala Insight Software

The probe can be connected to Vaisala Insight software using a Vaisala USB cable (order code: 257295). With the Insight software, you can:

- Calibrate and adjust the measurement.
- See device information and status.

- See real-time measurement.
- Configure serial communication settings, analog input and output parameters and scaling, and environmental compensations.

More Information

- [Connecting to Insight Software \(page 35\)](#)

2.3 Probe Parts

Figure 2 (page 13) shows the MGP261 main components with the connection box of the probe closed and opened.

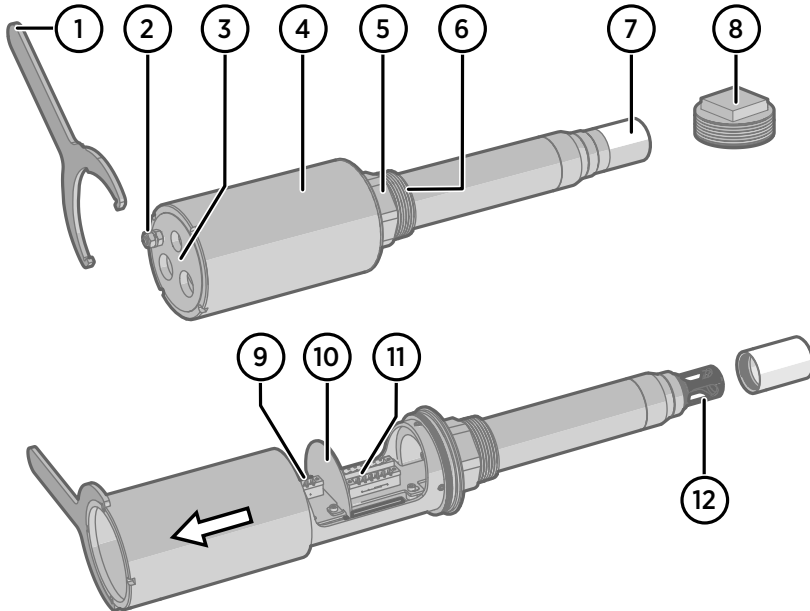

Figure 2 MGP261 Probe Parts (Closed and Opened View)

- 1 Connection box key
- 2 Grounding terminal
- 3 Lead-throughs for wiring: install cable glands as required (see [Cable Gland Options and Lead-Throughs \(page 14\)](#)) and seal unused lead-throughs
- 4 Connection box cover: open with connection box key to access wiring terminals
- 5 Tightening nut: only tighten from the tightening nut when installing
- 6 1.5" male NPT thread: **never install the probe to any other thread type than 1.5" female NPT thread**
- 7 Probe filter
- 8 1.5" NPT thread test plug
- 9 Wiring terminals for optional 4 ... 20 mA input from external pressure or temperature sensor (Ex ia)
- 10 Barrier separating the intrinsically safe (Ex ia) optional external sensor input terminals from the analog output, power supply input, and RS-485 terminals
- 11 Wiring terminals for 4 ... 20 mA analog outputs, 18 ... 30 VDC power supply input, and RS-485 communication
- 12 Measurement cuvette with optics and CARBOCAP® sensor inside the probe filter

2.3.1 Cable Gland Options and Lead-Throughs

Figure 3 (page 14) shows the MGP261 cable gland options and lead-through measurements.



Cable glands are not provided by Vaisala. When selecting cable glands for your application, note the requirements in [Guidelines for Safe Use in Hazardous Conditions](#) (page 17).

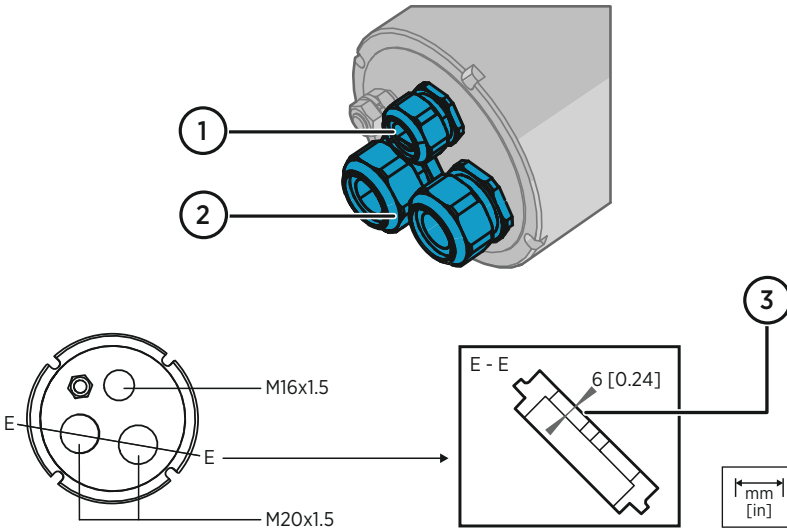

Figure 3 Cable Gland Options and Lead-Throughs

- 1 M16x1.5 wiring lead-through (1): used when wiring the optional Ex ia external pressure or temperature sensor input terminal
- 2 M20x1.5 wiring lead-throughs (2): used when wiring the analog output, power supply input, and RS-485 terminals
- 3 The depth of the lead-throughs is 6 mm (0.24 in): the maximum thread length for the plugs used in the lead-throughs is 8 mm (0.31 in) and the maximum cable gland length is 5 cm (1.97 in)

More Information

- [Preparing Probe for Installation](#) (page 26)
- [Wiring](#) (page 28)

2.4 Measurement Principle

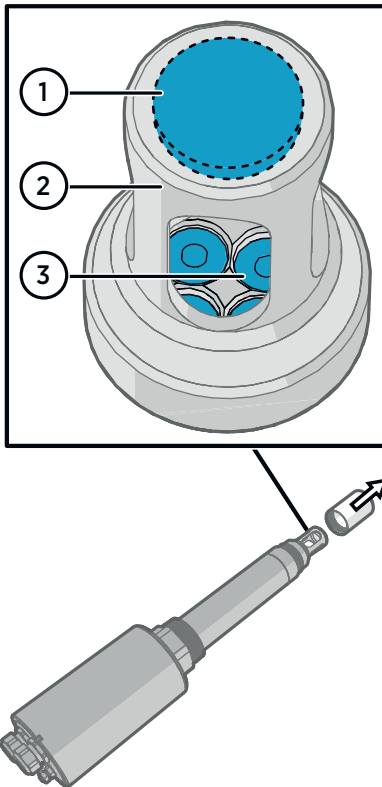

The Vaisala CARBOCAP® sensor used in the probe is a silicon-based, nondispersive infrared (NDIR) sensor for the measurement of methane (CH₄), carbon dioxide (CO₂), and humidity (H₂O).

Figure 4 Probe Cuvette with Mirror and Sensor Chips

- 1 Mirror
- 2 Cuvette
- 3 Sensor chips under TO5 packages

The sensitivity to gases is based on absorption of infrared light at a characteristic wavelength. During measurement, infrared light is routed through the cuvette that contains the gas to be measured. A mirror reflects the light from the cuvette to thermopile detectors that measure the light intensity at a wavelength determined by a Fabry–Pérot interferometer (FPI) and a band pass filter. One set of optics measures humidity and carbon dioxide, and a second one measures methane.

The measurement consists of two steps: first, the FPI is electrically tuned so that its pass band coincides with the characteristic absorption wavelength of the measured gas and the signal is recorded. Second, the pass band is shifted to a wavelength where no absorption occurs in order to get a reference signal. The ratio of these two signals, one at the absorption wavelength and the other at the reference wavelength, gives the fraction of light absorption from which the gas concentration is calculated. Measuring the reference signal compensates the possible effects of sensor aging and signal attenuation due to dirt on optical surfaces, making the sensor very stable over time.

TO5 packages with hermetic windows are used to protect the sensor chips from moisture and contamination. A heater chip is utilized to prevent condensation in normal operation.

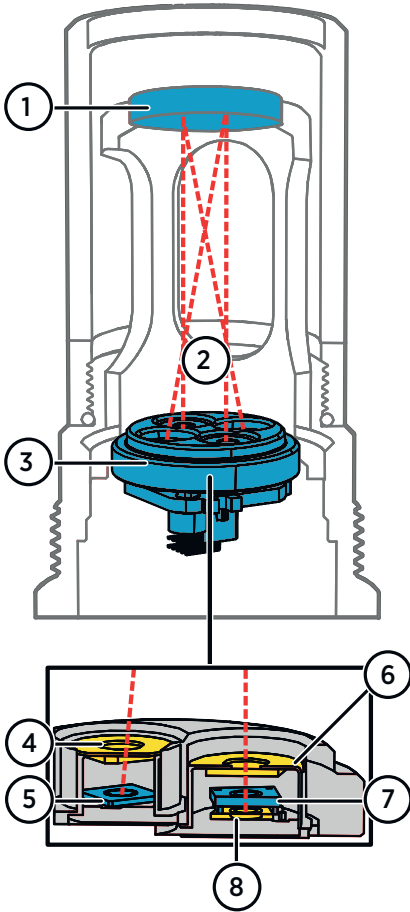

Figure 5 Measurement in the Measurement Cuvette

- 1 Mirror
- 2 Light absorbed by the measured gases
- 3 Sensor chips under TO5 packages (see items 4 ... 8)
- 4 Hermetic window
- 5 Thermopile detector
- 6 Hermetic window
- 7 Fabry-Pérot interferometer
- 8 Light source (Microglow)

More Information

- [Specifications \(page 62\)](#)

2.5 Using MGP261 in Hazardous Locations



WARNING! MGP261 has been designed for use in hazardous locations as specified by the product classification. The personnel installing, using, or maintaining the probe are responsible for determining the appropriate protection concept for the specific application the probe is used in, and that the hazardous area classification of the probe meets the requirements of the application.

MGP261 is certified for use in hazardous areas as defined by the following classification:



Ex II 1/2 (1) G Ex eb mb [ia] IIB T3 Ga/Gb -40 °C ≤ Tamb ≤ +60 °C



CAUTION! The personnel installing, operating, and maintaining MGP261 must have the required competencies for working in the hazardous location, as defined by the applicable standards.

For information on the standards that apply to using MGP261 based on the classification of the device, see MGP261 certification documentation and the declarations of conformity related to MGP261 at www.vaisala.com/declarationofconformity.

2.5.1 Guidelines for Safe Use in Hazardous Conditions

Process Connection and Partition Wall

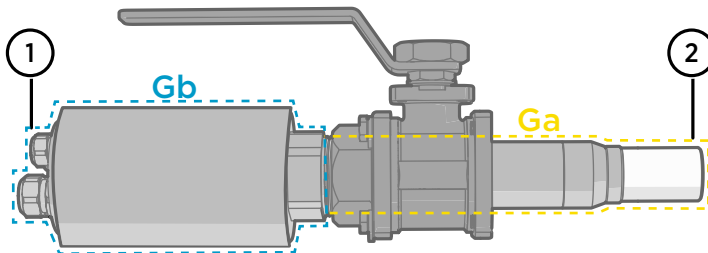

Figure 6 MGP261 Probe Ga/Gb Division

- 1 The part outside of the process (up until to the NPT 1.5" connection thread) complies with the **Gb** Equipment Protection Level (EPL).
- 2 The part inside the process (starting from the NPT 1.5" thread) complies with the **Ga** EPL. The partition wall is made of stainless steel, sapphire glass, and silicone adhesive. The stress limit temperature range of the silicone adhesive is -40 ... +60 °C (-40 ... +140 °F).



WARNING! While installing or uninstalling the device, there is a risk of flammable gas release or flame entrance.

Wiring Requirements

- The wiring of the optional intrinsically safe (Ex ia) external pressure or temperature sensor input terminal must be kept separate from the analog input, power supply input, and RS-485 wiring.
 - See the overview in the installation instructions.
- The cable glands and wires used for wiring MGP261 must be Ex compliant.
 - Unused lead-throughs must be sealed using Ex compliant plugs.
- Select a strain relief option that suits the application (either use cable glands that include strain relief or install separate clamps: see IEC 60079-14).
- See [Table 4 \(page 18\)](#) for screw terminal requirements.
- Permitted supply short-circuit current (I_k): 50 A
- MGP261 analog outputs must be externally powered.



CAUTION! Connect only de-energized wires. Never switch on the power supply input before completing the wiring and closing the connection box.

Screw Terminal Connections

Table 4 Screw Terminal Wiring Requirements

Property	Specification
Connection torque	0.5 Nm ... 0.6 Nm
Connection capacity (solid and flexible)	0.2 mm ² ... 2.5 mm ² (AWG 24 ... 12)
Stripping length	7 mm (0.27 in)

Intrinsic Safety

The overvoltage category of MGP261 is **I** (non-mains equipment), as defined in IEC 60664-1.

MGP261 is in conformance with the IEC 60079-11 dielectric strength requirement. For the intrinsic safe IIB output parameters, see [Table 5 \(page 18\)](#).

Table 5 Intrinsic Safe IIB Output Parameters

Parameter	Value
U_o	25.2 V
I_o	78 mA

Parameter	Value
P_o	0.5 W
U_m	40 V
C_o	820 nF
L_o	20 mH

The parameters listed in [Table 5 \(page 18\)](#) apply when one of the two conditions below is given:

- the total L_i of the external circuit (excluding the cable) is $< 1\%$ of the L_o value; or
- the total C_i of the external circuit (excluding the cable) is $< 1\%$ of the C_o value.

The parameters are reduced to 50% when both of the two conditions below are given:

- the total L_i of the external circuit (excluding the cable) is $\geq 1\%$ of the L_o value; and
- the total C_i of the external circuit (excluding the cable) is $\geq 1\%$ of the C_o value.

Note: the reduced capacitance of the external circuit (including cable) shall not be greater than $1\mu\text{F}$ for Groups I, IIA, IIB & IIIC, and 600nF for Group IIC.

The values of L_o and C_o determined by this method shall not be exceeded by the sum of all of the L_i plus cable inductances in the circuit and the sum of all of C_i plus cable capacitances, respectively.

Connecting Probe to Insight PC Software

The Insight PC software connection cable must only be used outside the explosion hazardous area. Remove the probe from the process for configuration, and use only the Vaisala accessory PC connection cable to connect the probe to Insight.

Maintenance

The probe filter is the only user-replaceable part in MGP261. For other maintenance requirements, contact Vaisala.



CAUTION! Live maintenance is not allowed.

The content in this chapter is maintained in the following separately tracked document:

Document ID: M212241EN

Revision: B (21 Jan 2019)

3. Installation

3.1 Overview

MGP261 can be installed either directly into the process (for example, through a flange or ball valve in the actual process pipeline), or using a flow-through adapter (for example, in a sampling line installation or when performing a field calibration).

For an overview of installing MGP261 directly in the process, see [Installation Option: Ball Valve Installation \(page 22\)](#)

For an overview of the flow-through adapter, see [Installation Option: Flow-Through Adapter Installation \(page 23\)](#)

MGP261 uses different internal calculation models depending on the installation type and gas flow rate. For this reason, the type of the installation must be set correctly in MGP261 settings. You can view and change the installation type configuration with Vaisala Insight PC software: for instructions, see [Installation Type Configuration in Insight \(page 33\)](#).



CAUTION! Always ensure that the installation type configuration is set correctly in Insight when changing from one installation type to another, so that the calculation model in use matches the installation environment and measurement accuracy is not affected.

3.1.1 Process Flow Range and Installation Type

A process flow range of 2 ... 20 m/s is suitable for the in situ installation calculation model. When operating the probe in a low flow environment (0 ... 2 m/s) or using the flow-through adapter, use the flow-through calculation model. To set the correct calculation model for the flow range, choose the installation type in the Vaisala Insight PC software.

Process Flow Range	Installation Type Selection in Insight PC Software
2 ... 20 m/s	Directly in process
0 ... 2 m/s or with flow-through adapter	Flow-through adapter

More Information

- [Installation Option: Ball Valve Installation \(page 22\)](#)
- [Installation Option: Flow-Through Adapter Installation \(page 23\)](#)
- [Installation Type Configuration in Insight \(page 33\)](#)
- [Connecting to Insight Software \(page 35\)](#)
- [Specifications \(page 62\)](#)

3.1.2 NPT 1.5" Thread Test Plug 257525SP

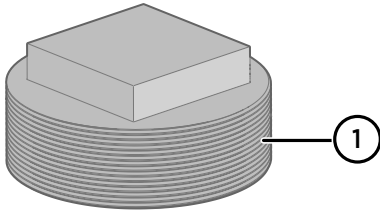

Figure 7 NPT 1.5" Thread Test Plug

- 1 NPT 1.5" male thread (same as on MGP261 connector)

MGP261 comes shipped with an NPT 1.5" male thread test plug (Vaisala order code: 257525SP). If you are uncertain about the thread type of the process connector you want to install MGP261 into, use the thread test plug to check that it fits into the process connector threads (that is, that the process connector thread type is **NPT 1.5" female**).

More Information

- [Inserting Probe into Process and Opening Connection Box \(page 27\)](#)

3.1.3 Installation Preparations

Before starting the installation, check the following:

- Make sure that your installation site suits the Ex classification of MGP261:
Ex II 1/2 (1) G Ex eb mb [ia] IIB T3 Ga/Gb -40 °C ≤ Tamb ≤ +60 °C
- Review the hazardous area information in [Using MGP261 in Hazardous Locations \(page 17\)](#) and make sure that the conditions for safe use are met.
- Review the wiring diagram included in this document for power supply requirements: MGP261 requires a dedicated 24 VDC power supply. Note that in addition to the power supply input for the probe, each analog output must be externally powered.
- Inspect the probe for any possible damage or dirt that could compromise the leak tightness of the device (for example, bent or punctured parts of the probe body, or dirt on the connection box threads preventing it from closing fully).
- When selecting the cable glands and plugs for your application, make sure they are Ex compliant.

More Information

- [Using MGP261 in Hazardous Locations \(page 17\)](#)
- [Wiring \(page 28\)](#)

3.1.4 Installation Option: Ball Valve Installation

Figure 1 shows an example MGP261 ball valve installation. The figure highlights the correct wiring routes and shows the recommended installation depth and orientation.



CAUTION! Always use a separate cable for the optional (Ex ia) external pressure or temperature sensor input wiring (1), and make sure the wiring remains separated from the terminals and wiring (2) on the other side of the metal barrier (3) on the component board.

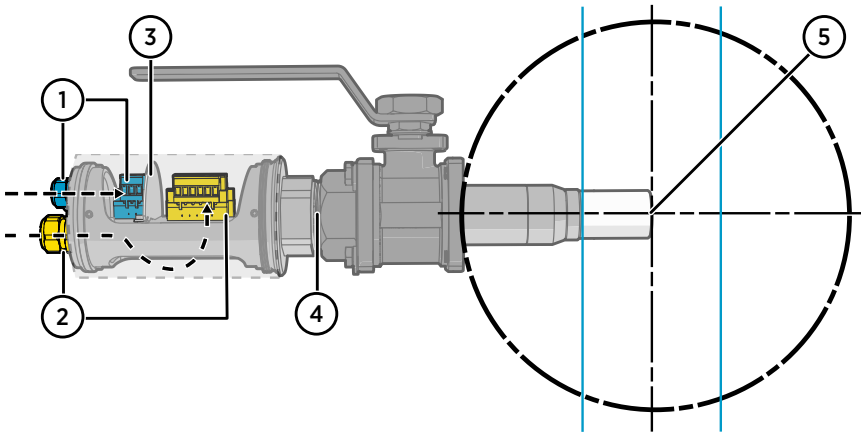

Figure 8 MGP261 Installation Example with Wiring Routes and Recommended Orientation and Depth

- 1 Optional external pressure or temperature sensor input wiring (Ex ia): use the M16x1.5 lead-through and route the cable directly to the terminal.
- 2 Standard analog output, power supply input, and RS-485 communication wiring: use the M20x1.5 lead-throughs and route the cables to the terminals through the openings below the component board.
- 3 Metal barrier separating the intrinsically safe external sensor input terminals (optional, for environmental compensation input) from the analog output, power supply input, and RS-485 terminals on the component board.
- 4 1.5" male NPT thread on MGP261: **never install to any other thread type than 1.5" female NPT.**
- 5 For best results, install MGP261 horizontally and position the tip of the filter within 1/3 of the pipe's diameter from the pipe centerline. In smaller pipes, the installation depth can be adjusted by using an adapter (for example, a ball valve).

More Information

- [Recommended Installation Position on Pipeline \(page 24\)](#)

3.1.5 Installation Option: Flow-Through Adapter Installation

Figure 9 (page 23) shows MGP261 attached into the MGP261 flow-through adapter accessory (Vaisala order code: 258877). For instructions on attaching MGP261 to the flow-through adapter, see [Attaching Flow-Through Adapter to MGP261](#) (page 31).

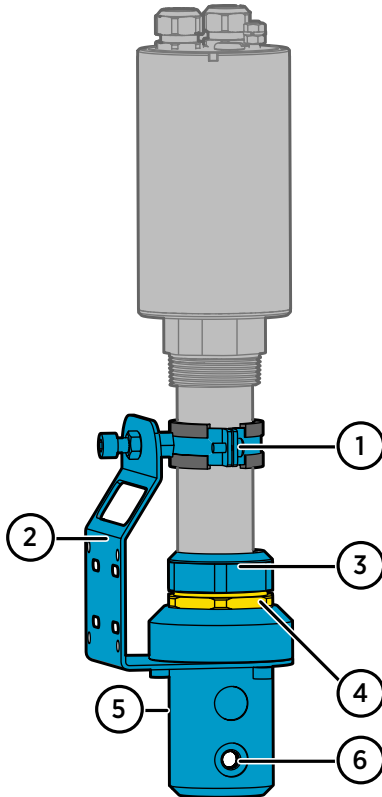

Figure 9 MGP261 in Flow-Through Adapter 258877

- 1 Clamp with 2 screws
- 2 Mounting plate (attach to mounting surface with screws or ties)
- 3 Probe gland tightening nut
- 4 Probe gland locknut: **do not turn**
- 5 Gas tube inlet port, G 1/8 (on the other side of the adapter)
- 6 Gas tube outlet port, G 1/8

More Information

- [Attaching Flow-Through Adapter to MGP261](#) (page 31)
- [Flow-Through Adapter Dimensions](#) (page 67)

3.1.6 MGP261 Dimensions

Figure 10 (page 24) shows the MGP261 dimensions. The figure also shows the cabling lead-through depth: for more information on cable gland options and lead-through dimensions, see Cable Gland Options and Lead-Throughs (page 14).

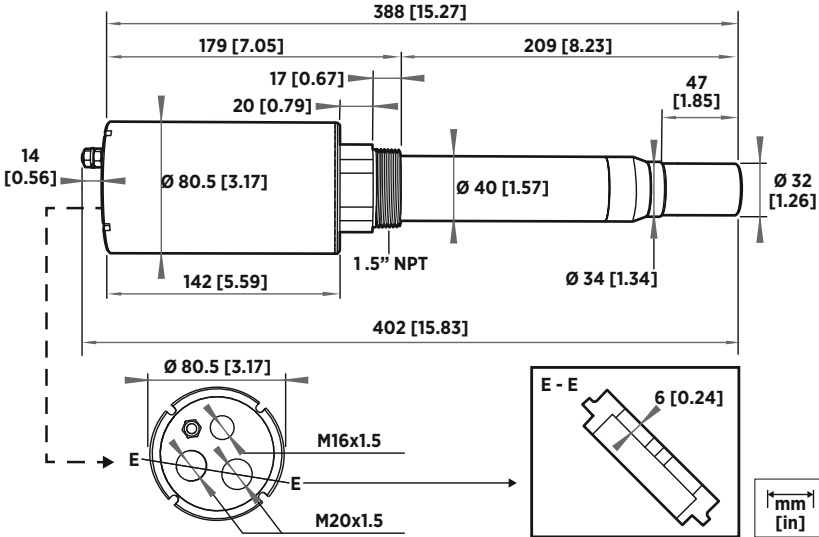

Figure 10 MGP261 Dimensions in Millimeters and Inches

3.1.7 Recommended Installation Position on Pipeline

Figure 11 (page 24) shows the recommended installation position for MGP261. Install the probe in a straight run of pipeline, ≥ 5 pipe diameters downstream of the closest bend or other feature affecting gas flow, and ≥ 2 pipe diameters upstream to the next bend or similar feature. For best results, use the orientation and installation depth shown in Figure 8 (page 22).

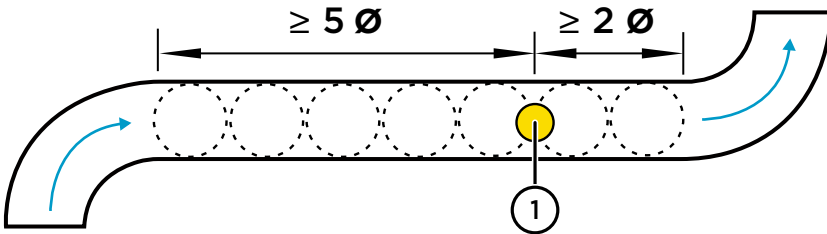

Figure 11 Recommended MGP261 Installation Position on Pipeline

- 1 Recommended MGP261 installation position on pipeline.

3.1.8 Gas Safety During Installation



WARNING! While installing or uninstalling the device, there is a risk of flammable gas release or flame entrance.



WARNING! Exposure to hazardous gases (for example, hydrogen sulfide (H₂S)) is possible when installing or removing MGP261 from the process.

- Always follow local safety guidelines. Ensure that the work area is safe and meets local regulations (for example, related to ventilation and personal protective equipment).
- Use a personal gas detector to monitor the safety of the area you are working in.
- After installation, use a gas detector to ensure that process connections are leak-free.



CAUTION! To avoid compromising the leak tightness of the installation:

- Ensure that the thread type of the installation port is 1.5" female NPT. If unsure, verify the thread type with the 1.5" NPT thread test plug.
- Apply PTFE tape to the 1.5" male NPT thread of MGP261 as instructed in [Preparing Probe for Installation \(page 26\)](#), and make sure that the PTFE tape seal has not been damaged by rotating the probe open (counter-clockwise) in the installation port.

3.2 Preparing Probe for Installation



The following tools are required when installing:

- Adjustable wrench (or a similar suitable tool) for turning the tightening nut
- Connection box key (provided)
- Input and output cables for wiring
- Small slotted screwdriver for screw terminals
- PTFE tape (wide) for the probe threads

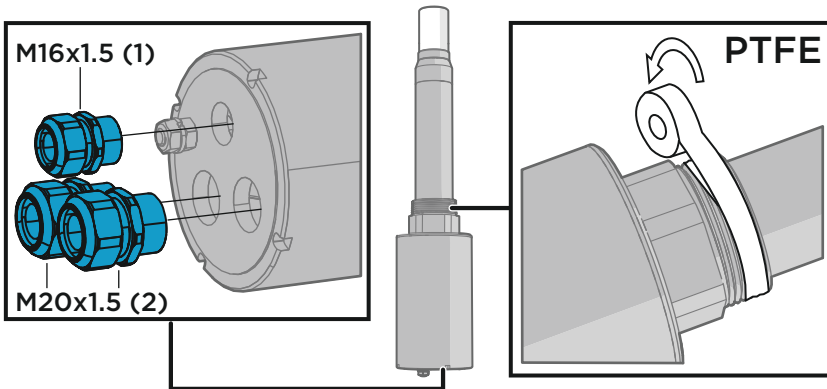

- ▶ 1. Attach cable glands (not provided by Vaisala) to the wiring lead-throughs as required. Note the cable gland requirements listed in [Guidelines for Safe Use in Hazardous Conditions \(page 17\)](#). For more information on cable gland options and lead-through dimensions, see [Cable Gland Options and Lead-Throughs \(page 14\)](#).
 - Use an M16x1.5 gland for the optional external sensor input wiring (Ex ia).
 - Use 1 or 2 M20x1.5 glands for wiring the 4 ... 20 mA analog output, power supply input and RS-485 terminals (as required in your application).
 - Seal unused lead-throughs.
2. Apply PTFE tape on the probe threads.
 - Inspect the threads and remove any possible dirt.
 - Wrap 2-3 revolutions of tape in the direction of the thread spiral, starting from the first thread. Keep the edge of tape parallel to the face of the thread while wrapping.
 - Do not tape beyond the edge of the threads or leave loose tape hanging.



CAUTION! The correct thread type in which to install MGP261 is **1.5" female NPT**. Installing into any other thread type can damage the equipment and compromise the leak tightness of the connection. If unsure, verify the thread type with the NPT 1.5" thread test plug.

3.3 Inserting Probe into Process and Opening Connection Box

1. Insert the probe into the **1.5" female NPT** installation port and rotate it clockwise until it sits firmly in the port. Do not tighten the probe to full tightness, only enough to keep it securely in place when wiring.

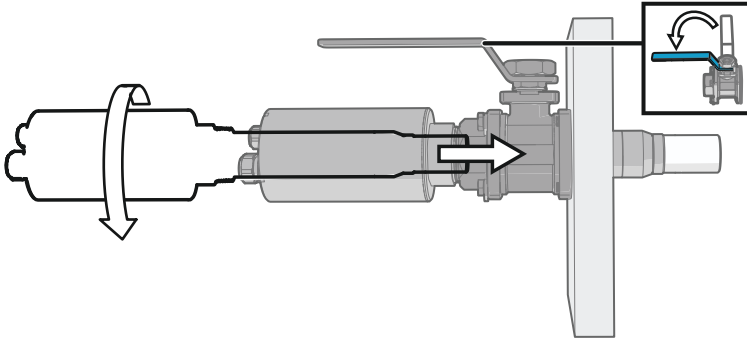

CAUTION! Rotating the probe open (counter-clockwise) after it has been installed into the port can tear the PTFE tape. Only adjust the position of the probe in the installation port by tightening (rotating clockwise).

2. Hold the probe by gripping the tightening nut with a wrench. Then open the connection box cover by turning the cover counter-clockwise with the connection box key.

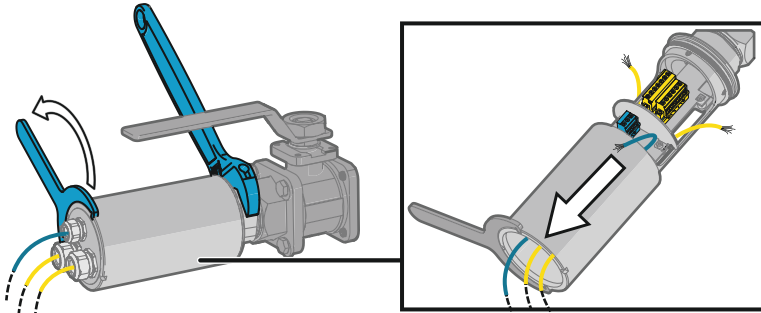

For easier access, loosen the cable glands and insert the wiring cables into the connection box before pulling the connection box cover open.

3. Pull the connection box cover open to access the wiring terminals.

3.4 Wiring

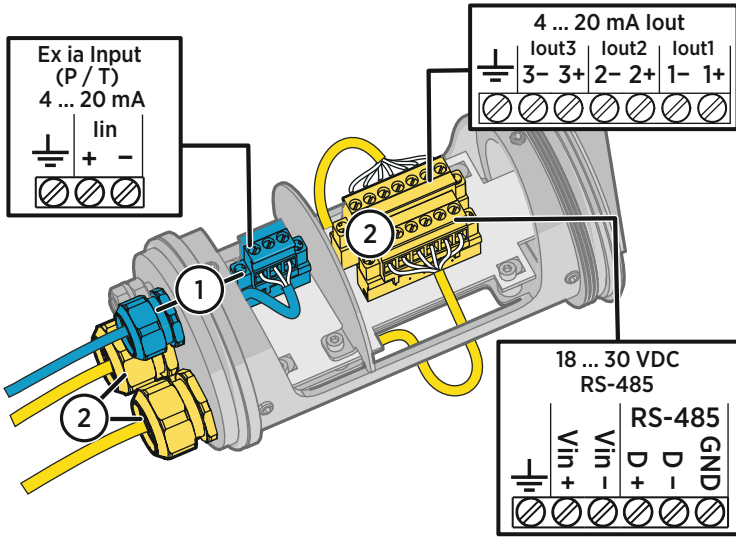

Figure 12 MGP261 Screw Terminal Markings and Cable Routes



CAUTION! Connect only de-energized wires. Never switch on the power supply input before completing the wiring and closing the connection box.

- ▶ 1. Connect the input, output, and power supply wiring as required in your application. [Figure 13 \(page 29\)](#) shows an example of wiring the device when all inputs and outputs are used.
 - 1: Optional external pressure or temperature sensor input wiring (Ex ia): route the cable to the terminal through the M16x1.5 lead-through, above the component board.
 - 2: Analog output, power supply input, and RS-485 wiring: route the cables to the terminals through the M20x1.5 lead-throughs (1 or 2), below the component board.
 - Adjust cable length and attach strain relief (tighten cable glands or use clamps).



CAUTION! The optional Ex ia external sensor input wiring (1) must be kept separate from the analog output, power supply, and RS-485 wiring (2). Always use separate cables on each side of the metal barrier.

2. See [Finalizing Installation \(page 30\)](#) for instructions on attaching grounding to the probe grounding terminal.

3.4.1 Wiring Diagram

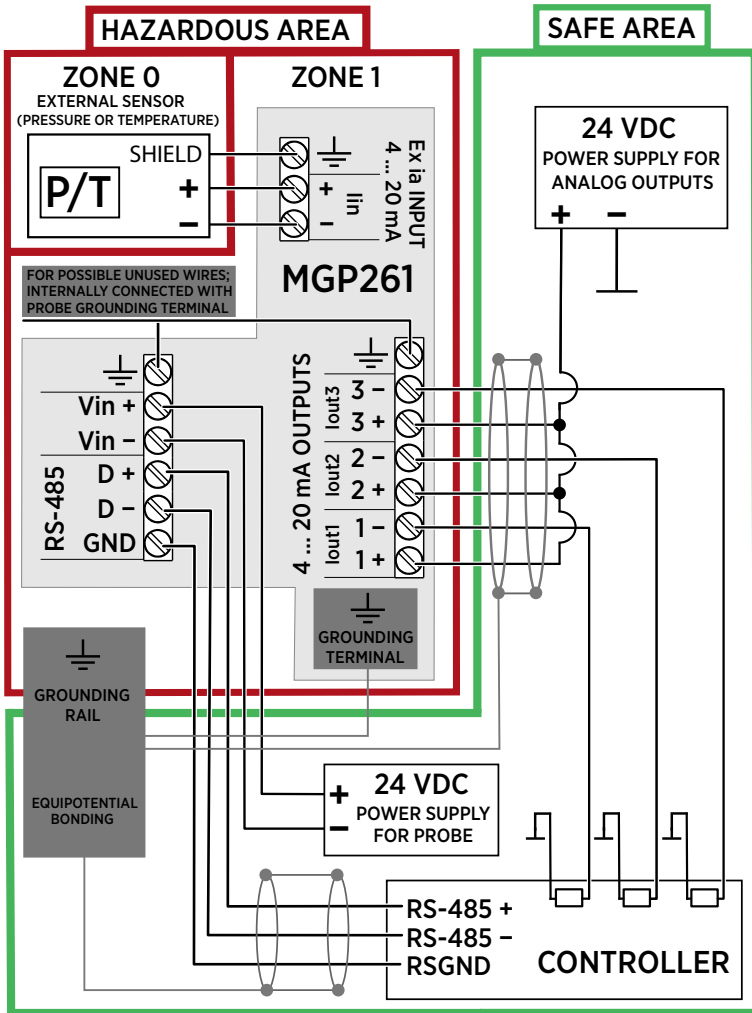
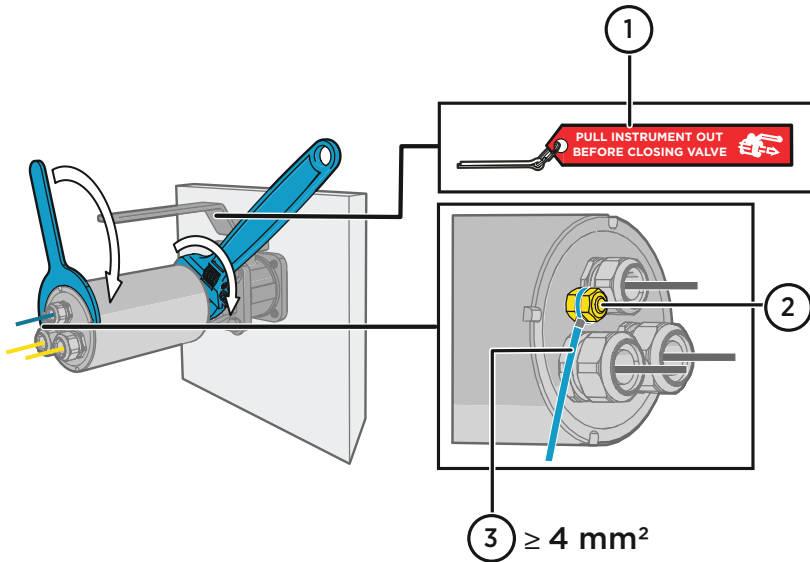

Figure 13 MGP261 Wiring Diagram

3.5 Finalizing Installation



- 1 Safety pin: in ball valve installations, lock the handle of the ball valve in the open position with the safety pin to prevent damage caused by closing the valve with the instrument inside.
 - 2 MGP261 grounding terminal.
 - 3 Use a $\geq 4 \text{ mm}^2$ wire to connect the grounding terminal to the grounding rail of the installation site.
- 1. Close and tighten the connection box ($< 0.55 \text{ mm}$ cover gap) and cable glands, and tighten the probe to final tightness on the installation port by turning the tightening nut with the wrench.
2. Connect the MGP261 grounding terminal to the grounding rail of the installation site with a $\geq 4 \text{ mm}^2$ wire.
 3. **Ball valve installations only:** lock the handle of the ball valve in the open position with the safety pin.
 4. When done, switch on the power supply input.

More Information

- [Installation Type Configuration in Insight \(page 33\)](#)

3.6 Attaching Flow-Through Adapter to MGP261

The MGP261 flow-through adapter 258877 is delivered assembled and is intended to be used with the probe installed in an upright position. For an overview of the flow-through adapter, see [Installation Option: Flow-Through Adapter Installation \(page 23\)](#).

To attach the adapter to MGP261:

1. Loosen the 2 screws on the clamp.

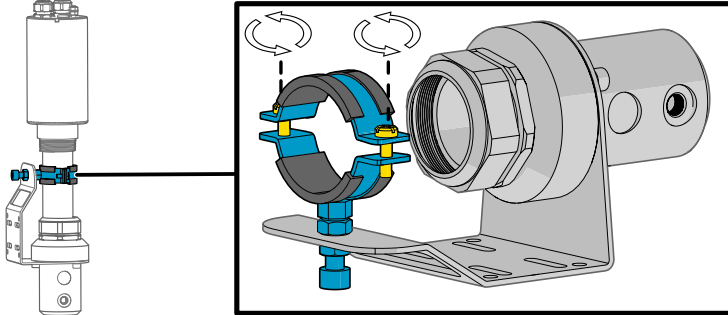

2. Loosen the probe gland.

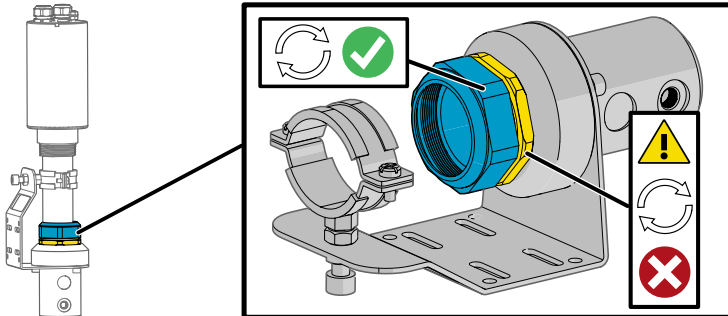

CAUTION! Only rotate the tightening nut of the probe gland. Never turn from the locknut of the probe gland (below the tightening nut). The threads of the locknut are glued onto the adapter with a sealant, and rotating the locknut will compromise the leak tightness of the adapter.

3. Insert the probe head into the adapter through the clamp and probe gland. Push the probe into the adapter until the shoulder of the probe head meets the slot inside the adapter and stops. The probe filter should cover both the inlet and outlet ports from the inside. Check the installation depth measurement as shown in [Figure 29 \(page 67\)](#).
4. Tighten the probe gland.

- After tightening the probe gland, tighten the 2 screws on the clamp.



WARNING! A high process pressure can cause the probe to detach from the adapter if the clamp and gland have been left loose. Always fully tighten the clamp and probe gland.

- Attach the mounting plate to the mounting surface with screws or ties. For mounting plate dimensions, see [Figure 30 \(page 67\)](#).
- Check that the probe sits closely in the clamps after mounting. The mounting kit and the flow-through adapter have been aligned so that the probe sits in the adapter in a straight angle. A gap between the probe body and clamp indicates that the mounting alignment is incorrect and must be adjusted.

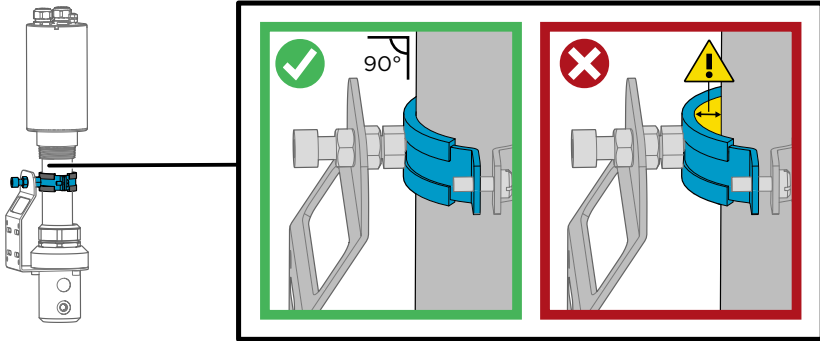

CAUTION! Ensure the adapter mounting does not pull the probe out of a straight angle. If the mounting pulls the probe to the side, the leak tightness of the gland O-ring can be affected.

- Connect the gas inlet tube to the upper port of the adapter and the gas outlet tube to the lower port. Adapter port size: G 1/8.
- Connect to Vaisala Insight PC software and ensure that the installation type has been set as **Flow-through adapter**. For instructions, see [Installation Type Configuration in Insight \(page 33\)](#).

More Information

- [Installation Type \(page 11\)](#)
- [Installation Option: Flow-Through Adapter Installation \(page 23\)](#)
- [Installation Type Configuration in Insight \(page 33\)](#)
- [Flow-Through Adapter Dimensions \(page 67\)](#)

3.7 Installation Type Configuration in Insight

Vaisala Insight PC software allows configuring the installation type of MGP261. The available options are **Directly in process** and **Flow-through adapter**.



When the selected installation type is **Flow-through adapter**, the internal calculation model is adapted to the flow-through environment. Always set the installation type according to the installation to ensure the correct calculation model is used.

The screenshot shows the 'Configure Device' window for an MGP261 probe in 'Advanced Mode'. The window has a sidebar on the left with menu items: 'Compensation power-up defaults', 'Compensation setpoints', 'Measurement' (highlighted), 'Communication', and 'Analog output 1'. The main area is titled 'Configure Device MGP261' and contains several configuration fields:

- 'Pressure compensation mode' set to 'Off'.
- 'Temperature compensation mode' set to 'Measured'.
- 'Installation type' dropdown menu is open, showing three options: 'Directly in process' (highlighted), 'Directly in process', and 'Flow-through adapter'.

Figure 14 Installation Type Selection in Insight

If you install your probe directly into the process, for example, through a flange or ball valve in the actual pipeline, select **Directly in process**.

If you are using the probe with a flow-through adapter, for example, in a sampling line installation, select **Flow-through adapter**.

To configure the installation type:

1. Connect to Insight (see [Connecting to Insight Software \(page 35\)](#)).
2. Select > **Configure Device** > **Measurement**.
3. Select the correct **Installation type** from the dropdown menu (either **Directly in process** or **Flow-through adapter**).
4. Store the selection with **Save** and exit with **Close**.

More Information

- [Installation Type \(page 11\)](#)
- [Connecting to Insight Software \(page 35\)](#)

4. Operating with Insight Software

4.1 Vaisala Insight Software

Vaisala Insight software is a configuration software for Indigo-compatible probes. The supported operating systems are Windows 7 (64-bit), Windows 8.1 (64-bit), and Windows 10 (64-bit).

With the Insight software, you can:

- See device information and status.
- See real-time measurement.
- Configure serial communication settings, analog input and output parameters and scaling, and environmental compensations.
- Calibrate and adjust the device.

Download Vaisala Insight software at www.vaisala.com/insight.

The probe can be connected to Vaisala Insight software using a Vaisala USB cable (no. 257295).

More Information

- [Connecting to Insight Software \(page 35\)](#)
- [Insight Main View \(page 37\)](#)
- [Configuring Modbus Communication Settings with Insight \(page 39\)](#)
- [Configuring Analog Outputs with Insight \(page 40\)](#)
- [Configuring Environmental Compensations with Insight \(page 44\)](#)
- [Calibration and Adjustment with Insight PC Software \(page 52\)](#)

4.1.1 Basic and Advanced User Modes

You can switch between the **Basic Mode** and **Advanced Mode** user modes with the selections in the **Settings** menu.

Certain functionalities are only available in **Advanced Mode**. The options enabled by switching to **Advanced Mode** are often intended for administrative users: set the user mode according to the requirements of the personnel that use the device.

More Information

- [Insight Main View \(page 37\)](#)

4.2 Connecting to Insight Software



- Computer with Vaisala Insight software installed
- USB connection cable (no. 257295)
- Small flat head screwdriver for opening the screw terminal block screws



CAUTION! The Insight PC software connection cable must be used only outside the explosion hazardous area. Remove the probe from the process for configuration, and use only the Vaisala accessory PC connection cable 257295 to connect the probe to Insight.

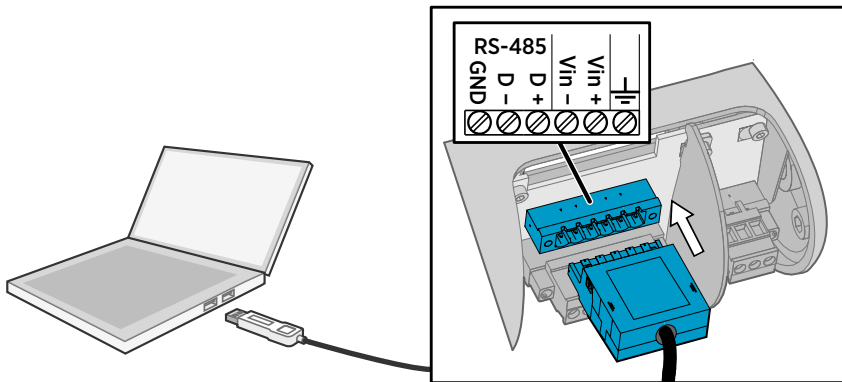

Figure 15 Connecting Probe to Insight

- ▶ 1. Open the Insight software.
2. Connect the USB cable to a free USB port on the PC.
3. Open the MGP261 connection box.
4. Unscrew the 6-pin screw terminal block on the MGP261 component board and lift the block out.
5. Plug the USB cable into the open port as shown in the illustration.
6. Wait for Insight software to detect the probe.

More Information

- [Installing the Driver for the USB Service Cable \(page 36\)](#)
- [Removing Probe from Process \(page 59\)](#)

4.2.1 Installing the Driver for the USB Service Cable



Only Windows® operating systems are supported by the driver of the USB service cable.

- ▶ 1. Connect the USB service cable to a USB port on your computer. Windows® detects the new device and installs the appropriate driver.
2. Open **Devices and Printers** from the Windows® Start menu. Use search to find it if necessary (search for "devices").
3. Locate the cable in the list of devices:
 - If the device is listed as **Vaisala USB Device** with a COM port number in brackets, the cable is ready for use. Take note of the COM port number for later use.
 - If the device is listed as **Vaisala USB Instrument Cable** without a COM port number listed, you must install the driver manually.

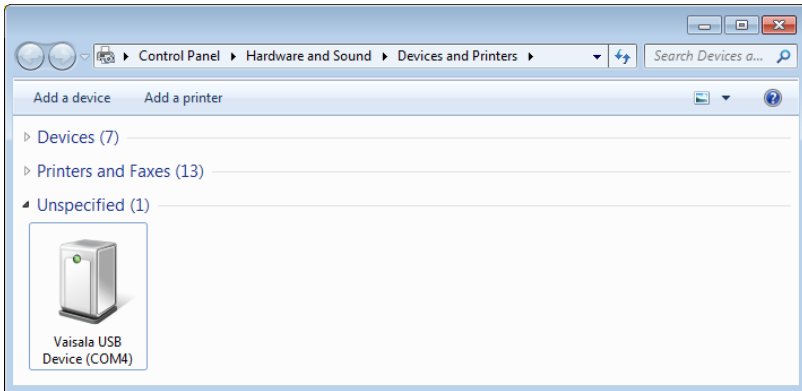

4. To install the driver manually:
 - a. Disconnect the USB service cable from the computer.
 - b. Download the Vaisala USB driver at www.vaisala.com/software (search and select the appropriate USB Instrument Driver Setup for your cable).
 - c. Run the USB driver installation program *Vaisala USB Device Driver Setup.exe*. Accept the installation defaults.
 - d. Go back to [step 1](#) and verify that the driver installation works as expected.

4.3 Insight Main View

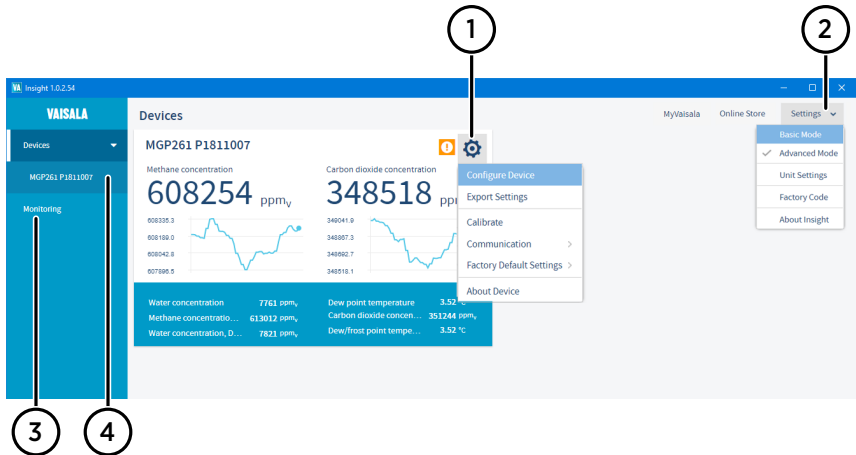



Figure 16 Insight Main Menu and Settings

1 Select  to access Insight main menu.

- **Configure Device:** environmental compensation settings, analog input and output settings, Modbus configuration, error limits and general settings.
- **Export Settings:** creates a text file export of the device settings.
- **Calibrate:** options for calibrating and adjusting methane, carbon dioxide, and water vapor output, viewing adjustment data, and restoring factory adjustments.
- **Communication:** contains a quick access selection for restarting the device.
- **Factory Default Settings:** restores the transmitter back to default settings, clears any user adjustments and restores the latest factory calibration.
- **About Device:** general device information such as serial number and software version.

2 Select **Settings** to switch between the **Basic Mode** and **Advanced Mode** user modes, change the units of parameters (metric/non-metric), enter a factory code to access restricted functionalities, or view information about the Insight software.

3 **Monitoring** provides options for monitoring and recording selected parameters, and exporting the monitoring data as a CSV (comma-separated values) file.

4 Device information menu with the following tabs:

- **Measurements:** measurement graph view with parameter drop-down selection.
- **Calibration Information:** read-only information about the latest stored calibration.
- **Diagnostics:** troubleshooting and administrative information about the device status. Also includes an option to export the device error log as a text file. When contacting Vaisala support, it is recommended to include an up-to-date export of the error log with the support request.

5. Modbus

The probe can be accessed using the Modbus serial communication protocol. The supported Modbus variant is Modbus RTU (Serial Modbus) over RS-485 interface.

The pre-configured default Modbus serial settings are presented in the following table. Modbus communication settings can also be configured using Vaisala Insight PC software.

For a description of MGP261 Modbus registers, see [Modbus Registers \(page 68\)](#).

Table 6 Default Modbus Serial Communication Settings

Description	Default Value
Serial bit rate	19200
Parity	N
Number of data bits	8
Number of stop bits	2
Modbus device address	240

More Information

- [Configuring Modbus Communication Settings with Insight \(page 39\)](#)
- [Modbus Registers \(page 68\)](#)

5.1 Configuring Modbus Communication Settings with Insight

The screenshot shows the 'Configure Device' window for device MGP261 P1811007. The window is titled 'Configure Device' and 'In Advanced Mode'. The left sidebar contains a list of configuration categories: Compensation power-up defaults, Compensation setpoints, Measurement, Communication (selected), Analog output 1, Analog output 2, Analog output 3, and Analog input 1. The main area displays the following settings:

Setting	Value
Address	240
Bit rate	19200 b/s
Parity, data, stop bits	N, 8, 1
Response delay	16 ms

At the bottom of the window, there are two buttons: 'Save' and 'Close'.

Figure 17 Modbus Communication Settings in Insight PC Software

You can configure the following Modbus communication settings with Insight PC software:

- Device address
- Communication bit rate
- Parity, data bits, and stop bits
- Response delay

To configure the Modbus communication settings with Insight:

1. Connect to Insight and select  > **Configure Device** > **Communication**.
2. Enter the communication values as needed: see the instructions in the Insight interface for allowed ranges and additional information.
3. Select **Save** to store the settings.

More Information

- [Connecting to Insight Software \(page 35\)](#)

6. Analog Output Configuration

6.1 Overview

MGP261 has 3 scalable 4 ... 20 mA analog output channels. Each output has the following configuration options:

- Output parameter selection
- Output scale low end and high end
- Error output level

The configuration of the outputs (output parameter selection and scaling) is selected when ordering the probe, and can be changed with Modbus or Vaisala Insight PC software.

6.2 Configuring Analog Outputs with Modbus

The Modbus implementation of MGP261 includes configuration registers for analog output measurement parameter selection, scaling, and error output level.

For a description of MGP261 Modbus registers, see [Modbus Registers \(page 68\)](#).

6.3 Configuring Analog Outputs with Insight

Configure Device		MGP261 P1811007		In Advanced Mode
Compensation power-up defaults	Output mode	4...20 mA		
Compensation setpoints	Output parameter	CH+ (dry)		
Measurement	Scale low end	0	ppm _v	
Communication	Scale high end	1000000	ppm _v	
Analog output 1	Error output	2.0	mA	
Analog output 2				
Analog output 3				
Analog input 1				

Save Close

Figure 18 Analog Output Configuration Options in Insight

You can configure the measurement parameter sent on each analog output, the scaling of the parameter, and the error output level. All 3 outputs have the same configuration options.

- ▶ 1. Connect to Insight (see [Connecting to Insight Software \(page 35\)](#)).
- 2. Select  > **Configure Device**, and then one of the 3 analog outputs.
- 3. Select the measurement parameter that is sent on the output channel you are configuring, set the scaling for the output, and define the output level that indicates an error.
- 4. Store the selections with **Save** and exit with **Close**.
- 5. Repeat the configuration for each output (analog outputs 1, 2, and 3) as required.

More Information

- ▶ [Wet Basis and Dry Basis Measurement Parameters \(page 42\)](#)



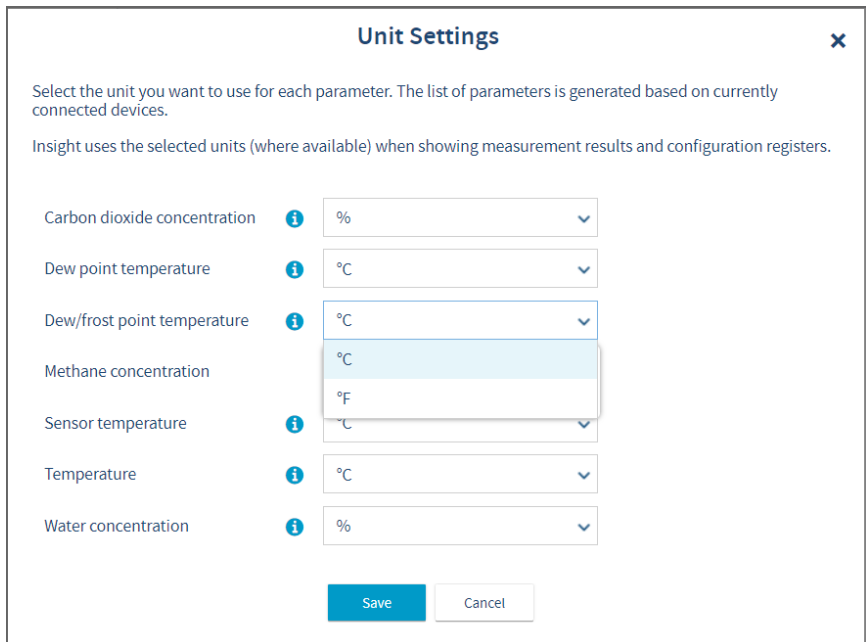



6.4 Changing Units in Insight



Unit Settings ✕

Select the unit you want to use for each parameter. The list of parameters is generated based on currently connected devices.

Insight uses the selected units (where available) when showing measurement results and configuration registers.

Carbon dioxide concentration		%
Dew point temperature		°C
Dew/frost point temperature		°C
Methane concentration		°C
Sensor temperature		°C
Temperature		°C
Water concentration		%

Save
Cancel

Figure 19 Unit Selection in Insight

You can change the units of parameters (for example, metric or non-metric temperature) in the **Unit Settings** menu in Insight.

- ▶ 1. Connect to Insight (see [Connecting to Insight Software \(page 35\)](#)).

2. In the **Settings** dropdown menu (upper right corner of the main view), select **Unit Settings**.
3. Select the units for the parameters and store the selections with **Save**.

6.5 Wet Basis and Dry Basis Measurement Parameters

MGP261 methane, carbon dioxide, and water vapor measurements can be shown either as wet basis or dry basis values. The wet basis / dry basis measurement output selection is made when ordering the probe, and can be configured with Vaisala Insight PC software or Modbus.

The following formula shows the conversion between wet basis and dry basis values.

$$X(dry) = \frac{X(wet)}{100\% - H_2O}$$

where:

- X(dry) gas concentration (dry basis) (%)
- X(wet) gas concentration (wet basis) (%)
- H₂O gas concentration (wet basis) (%)

Figure 20 (page 42) shows the analog output configuration options in Vaisala Insight Software with the available output parameters.

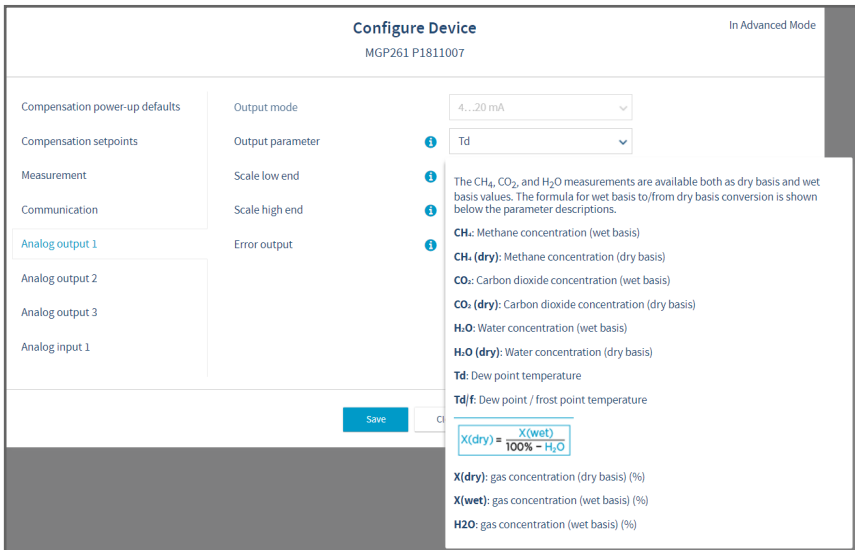

Figure 20 Output Parameter Selections in Vaisala Insight PC Software

7. Environmental Compensation

7.1 Overview

When necessary, environmental compensations can be applied to improve the measurement accuracy (for example, to provide the probe with a real-time pressure reading from the measurement environment by using input from an external sensor).

The probe can compensate for the effects of the following parameters:

- Temperature (T)
- Pressure (P)

Environmental compensation parameters can be provided to the probe from the following sources:

- The internal temperature sensor of the probe can be used for temperature compensation.
- An external sensor can be connected to the probe (4 ... 20 mA analog input, Ex ia) to provide temperature or pressure compensation values.
- If the temperature and pressure values are known and remain constant, they can be entered as fixed setpoint values.
- If the probe is integrated in a system that measures either temperature or pressure, they can be updated to the probe continuously.

The method used for environmental compensation is configured on the order form when ordering the probe, and can later be updated using Vaisala Insight PC software or Modbus protocol.

7.1.1 Temperature Compensation

MGP261 can measure the approximate temperature of the CARBOCAP® sensor for compensation, use a fixed setpoint value as the temperature compensation, or receive the temperature compensation value from an external temperature sensor.

Unless a dedicated temperature measurement is available and can be regularly updated to the probe, it is strongly recommended to use the probe's internal temperature compensation to ensure real-time accurate measurements. If the measurement is made in a constant temperature, the constant temperature can be set as the compensation value (fixed setpoint option).

7.1.2 Pressure Compensation

The probe does not have on-board pressure measurement. You can either configure a fixed setpoint value that is used as the pressure compensation, or set the probe to receive the pressure compensation value from an external pressure sensor.

7.1.3 Compensation Mode During Calibration

When you start to calibrate the probe with Insight, the probe enters calibration mode, and the compensation mode is automatically switched to **Setpoint**. In this compensation mode, you must enter the conditions of your calibration environment as temporary setpoint values in the **Compensation setpoints** tab of the calibration menu.

When you exit calibration mode, the values you have entered in the **Compensation setpoints** tab remain in use as the current setpoint values, but the compensation mode switches back to the selection that was in place before starting calibration (either **Off**, **Setpoint**, **Measured**, or **External**).

More Information

- [Configuring Environmental Compensations with Insight \(page 44\)](#)

7.2 Configuring Environmental Compensations with Modbus

The Modbus implementation of MGP261 includes configuration registers for pressure and temperature compensation setpoints. You can also configure the temperature and pressure compensation mode (**External**, **Setpoint**, **Measured** (temperature only), or **Off**).

For a description of MGP261 Modbus registers, see [Modbus Registers \(page 68\)](#).

More Information

- [Modbus \(page 38\)](#)
- [Modbus Registers \(page 68\)](#)

7.3 Configuring Environmental Compensations with Insight

Using Insight, you can configure the following temperature and pressure compensation settings:

- Temperature or pressure compensation mode (select the source where the compensation value is received from)
- The setpoint values for temperature or pressure compensation
- The scaling of the analog input channel (**Analog input 1**) that is used to receive temperature or pressure values from an external sensor.

[Figure 21 \(page 45\)](#) describes the different environmental compensation selections in Insight.

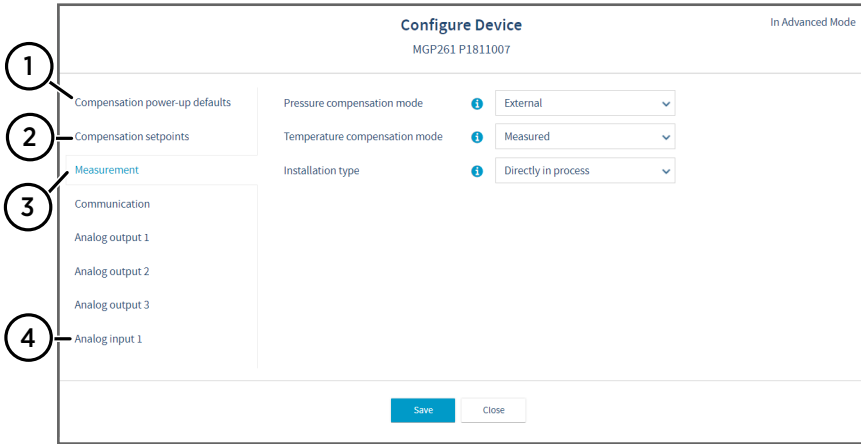



Figure 21 Measurement Menu View in Insight PC Software

- 1 **Compensation power-up defaults:** configure the setpoint compensation values that are taken into use at device reset. Used when the temperature or pressure compensation mode is set as **Setpoint**.
- 2 **Compensation setpoints:** configure the temporary setpoint compensation values that are in use while the device is powered on, but revert back to power-up defaults when the device is reset. Used when the temperature or pressure compensation mode is set as **Setpoint**.
- 3 **Measurement** (shown in figure): configure the pressure and temperature compensation modes (available options: **Setpoint**, **External**, **Measured** (temperature only), and **Off**).
- 4 **Analog input 1:** configure the input from the external pressure or temperature sensor (used when the pressure or temperature compensation mode is set as **External**).

- ▶ 1. Connect to Insight (see [Connecting to Insight Software \(page 35\)](#)),
2. Select  > **Configure Device**.
3. Select one of the compensation modes in the **Measurement** menu.
4. See the separate instructions for configuring the compensations in each compensation mode:
 - [Configuring Setpoint Values for Compensations with Insight \(page 46\)](#)
 - [Using Probe Measurement as Temperature Compensation \(page 46\)](#)
 - [Using Compensation Received from External Temperature or Pressure Sensor \(page 46\)](#)
 - [Configuring Input from External Analog Pressure or Temperature Sensor \(page 47\)](#)

More Information

- ▶ [Compensation Mode During Calibration \(page 44\)](#)

7.3.1 Configuring Setpoint Values for Compensations with Insight

To configure a fixed setpoint value for pressure or temperature compensation in Insight:

- ▶ 1. Select  > **Configure Device**.
- 2. Open the **Measurement** menu, set the compensation mode of the compensation parameter (temperature, pressure, or both) as **Setpoint** from the mode selection dropdown list, and select **Save** when done.
- 3. Open the **Compensation setpoints** menu, enter the setpoint value in the text field, and select **Save** when done.



Note that the setpoint value you enter in the **Compensation setpoints** is temporary and resets back to the power-up default at device reset.

- 4. Optional: If you want to keep the setpoint value in use also after device reset, enter the same value in the **Compensation power-up defaults** menu and store the setting by selecting **Save**.

7.3.2 Using Probe Measurement as Temperature Compensation

To set the internal temperature measurement of the probe as the temperature compensation source:

- ▶ 1. Select  > **Configure Device**.
- 2. Open the **Measurement** menu.
- 3. Select **Measured** from the **Temperature compensation mode** dropdown list, and then select **Save**.

7.3.3 Using Compensation Received from External Temperature or Pressure Sensor

If you have connected an external pressure or temperature sensor to the 4 ... 20 mA Ex ia analog input channel of MGP261 (see [Wiring \(page 28\)](#)), you can use the measurement received from the sensor as the environmental compensation.



You can receive the compensation value from an external sensor for only one parameter (temperature or pressure) at a time.

To use an external sensor for temperature or pressure compensation:

- ▶ 1. Select  > **Configure Device**.
- 2. Open the **Measurement** menu.

3. Select **External** from either the **Pressure compensation mode** or the **Temperature compensation mode** dropdown list, and then select **Save**.
4. Open the **Analog input 1** menu and configure the scaling of the external sensor input. See [Configuring Input from External Analog Pressure or Temperature Sensor \(page 47\)](#).

7.3.4 Configuring Input from External Analog Pressure or Temperature Sensor

When you set either the **Temperature compensation mode** or **Pressure compensation mode** to use measurement from an **External** sensor, you can configure the scale of the external sensor input in the **Analog input 1** menu.

The **Input mode** and **Input parameter** selections are set automatically based on the external compensation parameter selection.

The screenshot shows the 'Configure Device' interface for an MGP261 sensor. The title bar includes 'Configure Device' and 'In Advanced Mode'. The main content area is divided into two columns. The left column contains a vertical menu with options: 'Compensation power-up defaults', 'Compensation setpoints', 'Measurement', 'Communication', 'Analog output 1', 'Analog output 2', 'Analog output 3', and 'Analog input 1' (which is highlighted in blue). The right column displays the configuration for 'Analog input 1':

- Input mode:** A dropdown menu set to '4...20 mA'.
- Input parameter:** A dropdown menu set to 'P (comp.)'.
- Scale low end:** A text input field containing '0' with an information icon (i) to its left, followed by the unit 'hPa'.
- Scale high end:** A text input field containing '8000' with an information icon (i) to its left, followed by the unit 'hPa'.
- Input value:** An empty text input field followed by the unit 'hPa'.

 At the bottom of the configuration area, there are two buttons: a blue 'Save' button and a white 'Close' button.

Figure 22 Analog Input 1 Configuration Menu in Insight

- ▶ 1. In the **Measurement** menu, set either the pressure or temperature compensation mode as **External** to use input from a connected sensor. See [Using Compensation Received from External Temperature or Pressure Sensor \(page 46\)](#).



You can receive the compensation value from an external sensor for only one parameter (temperature or pressure) at a time.

2. Store the setting with **Save**.
3. In the **Analog input 1** menu, enter the scaling for the temperature or pressure input from the external sensor.

4. Store the setting with **Save**.

8. Calibration

8.1 Calibration Overview

The methane (CH₄) and carbon dioxide (CO₂) measurements of MGP261 can be calibrated and adjusted using gas references with known values. You can also calibrate and adjust the probe's internal temperature measurement (used for environmental compensation only). The H₂O measurement can only be adjusted at the low end (simultaneously with CH₄ and CO₂ when a zero point adjustment is made).

Carrying out calibrations and adjustments requires connecting MGP261 to Vaisala Insight PC software (requires Vaisala USB cable 257295). For instructions on connecting the probe to Insight, see [Connecting to Insight Software \(page 35\)](#).

To feed reference gases to MGP261 in a controlled manner when calibrating and adjusting, use a flow-through adapter. An MGP261 flow-through adapter is available as an optional accessory: for more information, see [Flow-Through Adapter \(page 50\)](#).



WARNING! Before removing the probe from the process for calibration and adjustment, review the instructions in [Removing Probe from Process \(page 59\)](#).

The following calibration and adjustment options are available when the probe is connected to Vaisala Insight PC software:

- Methane (CH₄) and carbon dioxide (CO₂) measurement calibration and adjustment (1-point or 2-point adjustments).
- Temperature measurement adjustment (probe's internal sensor measurement used only for environmental compensation).
- Zero point adjustment for all gas measurement parameters (CH₄, CO₂, and H₂O: adjusts all parameters simultaneously). Zero point adjustment replaces the low end adjustment of all gas parameters in 2-point adjustments.
- Reset to factory adjustment (given separately for each parameter).



The accuracy of field calibration and adjustment is dependent on a number of factors such as sufficient stabilization time, calibration setup conditions, and reference quality. To ensure fully accurate calibration and adjustment results, use the traceable calibration and adjustment services provided by Vaisala.

More Information

- [Connecting to Insight Software \(page 35\)](#)
- [Flow-Through Adapter \(page 50\)](#)
- [Removing Probe from Process \(page 59\)](#)

8.1.1 Compensation Mode During Calibration

When you start to calibrate the probe with Insight, the probe enters calibration mode, and the compensation mode is automatically switched to **Setpoint**. In this compensation mode, you must enter the conditions of your calibration environment as temporary setpoint values in the **Compensation setpoints** tab of the calibration menu.

When you exit calibration mode, the values you have entered in the **Compensation setpoints** tab remain in use as the current setpoint values, but the compensation mode switches back to the selection that was in place before starting calibration (either **Off**, **Setpoint**, **Measured**, or **External**).

More Information

- [Configuring Environmental Compensations with Insight \(page 44\)](#)

8.1.2 Flow-Through Adapter

The MGP261 flow-through adapter (Vaisala order code: 258877) is used in sampling line installations and field calibration and adjustment to achieve a controlled flow of gas to the probe.

The flow-through adapter is delivered assembled with a mounting clamp, mounting plate, and a gland for attaching the probe to the adapter. [Figure 23 \(page 50\)](#) shows the main parts of the flow-through adapter and mounting kit.

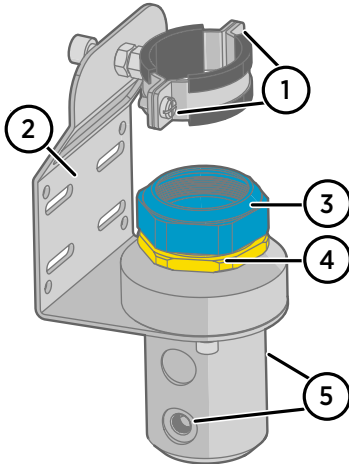

Figure 23 Flow-Through Adapter 258877

- 1 Probe clamp (industrial M8, 38-44 mm, insulated) and tightening screws
- 2 Mounting plate for screw or cable mounting
- 3 Probe gland (M50/9x1.5, 37.0 - 42.0 mm) tightening nut for inserting and removing the probe: **only open and tighten from the tightening nut**
- 4 Probe gland locknut: locked to the threads with Loctite threadlocker, **do not rotate**
- 5 Gas tube inlet and outlet ports (G 1/8) on opposite sides of the adapter body



For instructions on attaching the flow-through adapter and setting the correct installation type configuration in Vaisala Insight PC software, see [Attaching Flow-Through Adapter to MGP261 \(page 31\)](#).

More Information

- [Installation Option: Flow-Through Adapter Installation \(page 23\)](#)
- [Attaching Flow-Through Adapter to MGP261 \(page 31\)](#)
- [Installation Type Configuration in Insight \(page 33\)](#)
- [Flow-Through Adapter Dimensions \(page 67\)](#)

8.2 Calibration and Adjustment with Insight PC Software

Figure 21 (page 45) describes the calibration and adjustment selections in Insight.

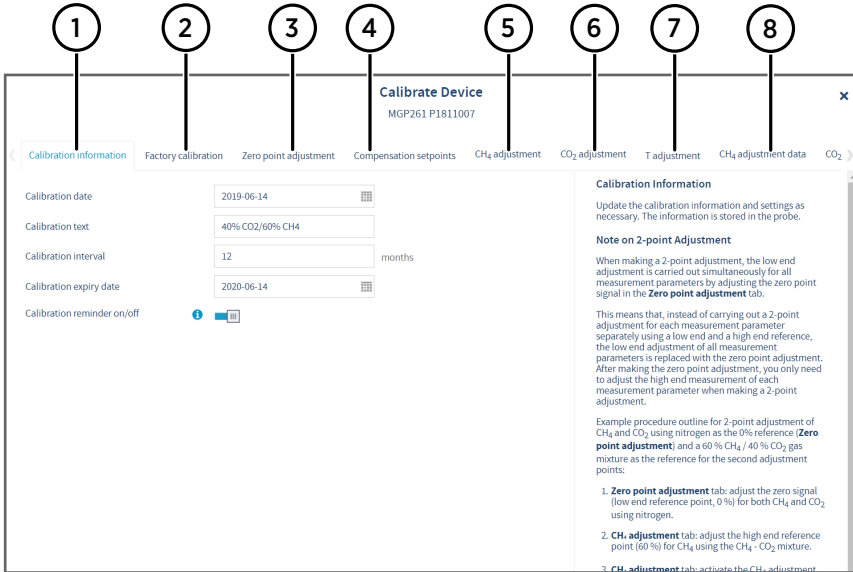



Figure 24 Calibration Menu View in Insight PC Software

- 1 Calibration information: enter information about the latest calibration (date, text description) in this tab. Also includes the calibration interval and calibration reminder selections.
- 2 Factory calibration: shows read-only information about the factory calibration.
- 3 Zero point adjustment: adjusts the zero point signal (simultaneously for all gas measurement parameters). This adjustment replaces the low end adjustment in 2-point adjustments.
- 4 Compensation setpoint configuration for the calibration and adjustment environment.
- 5 Methane (CH₄) measurement adjustment tab. In 2-point adjustments, use this tab for high end adjustment and the zero point adjustment for low end adjustment.
- 6 Carbon dioxide (CO₂) measurement adjustment tab. In 2-point adjustments, use this tab for high end adjustment and the zero point adjustment for low end adjustment.
- 7 Temperature measurement adjustment tab.
- 8 Adjustment data tabs show the latest stored adjustment for each parameter. Use the scroll arrows next to the menu tabs on the left and right edge of the view to view all tabs.

- 1. Connect to Insight (see [Connecting to Insight Software \(page 35\)](#)),

2. Select  > **Calibrate** > **Yes**.
3. Select one of the adjustment options in the **Calibrate** menu and see the separate instructions for each option.

8.2.1 Example: 2-Point Adjustment with Zero Point Adjustment

When making a 2-point adjustment, the low end adjustment is carried out simultaneously for all measurement parameters by adjusting the zero point signal in the **Zero point adjustment** tab.

This means that, instead of carrying out a 2-point adjustment for each measurement parameter separately using a low end and a high end reference, the low end adjustment of all measurement parameters is replaced with the zero point adjustment. After making the zero point adjustment, you only need to adjust the high end measurement of each measurement parameter when making a 2-point adjustment.

Example procedure outline for 2-point adjustment of CH₄ and CO₂ using nitrogen as the 0% reference (**Zero point adjustment**) and a 60 % CH₄ / 40 % CO₂ gas mixture as the reference for the second adjustment points:

- ▶ 1. **Zero point adjustment** tab: adjust the zero signal (low end reference point, 0 %) for both CH₄ and CO₂ using nitrogen.
- 2. **CH₄ adjustment** tab: adjust the high end reference point (60 %) for CH₄ using the CH₄ - CO₂ mixture.
- 3. **CH₄ adjustment** tab: activate the CH₄ adjustment.
- 4. **CO₂ adjustment** tab: adjust the high end reference point (40 %) for CO₂ using the CH₄ - CO₂ mixture.
- 5. **CO₂ adjustment** tab : activate the CO₂ adjustment.

8.2.2 Zero Point Adjustment

The zero point adjustment adjusts the zero output signal of the probe and applies simultaneously to all gas measurement parameters (CH₄, CO₂, and H₂O). This means that, instead of carrying out a 2-point adjustment for each gas measurement parameter separately using a low end and high end reference, the low end adjustment of all gas measurement parameters is replaced with the zero point adjustment.

After carrying out the zero point adjustment, you only need to adjust the high end measurement of each gas measurement parameter when carrying out a 2-point adjustment.



Always use nitrogen as the reference gas for the zero point adjustment.

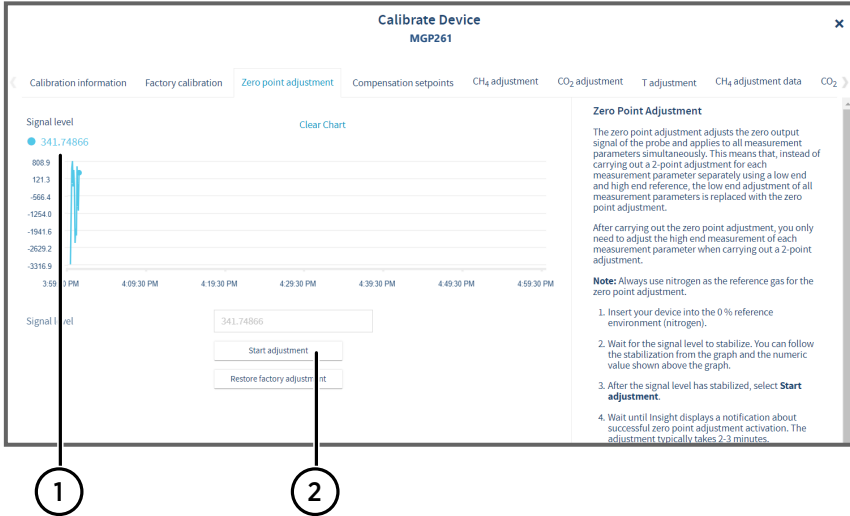

Figure 25 Zero Point Adjustment Tab

- 1 Follow the signal stabilization from the graph and the numeric value shown above the graph.
- 2 After the signal has stabilized, select **Start adjustment** and wait for the notification message about successful zero point adjustment activation. The adjustment is saved automatically.

- ▶ 1. Insert your device into the 0 % reference environment (nitrogen).
- 2. Wait for the signal level to stabilize. You can follow the stabilization from the graph and the numeric value shown above the graph.
- 3. After the signal level has stabilized, select **Start adjustment**.
- 4. Wait until Insight displays a notification about successful zero point adjustment activation. The adjustment typically takes 2-3 minutes.
- 5. The zero point adjustment is saved automatically after it has been successfully activated. To remove an incorrect adjustment, select **Restore factory adjustment**.
- 6. For a 2-point adjustment, carry out the high end adjustments for each measurement parameter in the separate adjustment tabs using appropriate references (for example, a 60 % CH₄ / 40 % CO₂ gas mixture).

8.2.3 Calibrating and Adjusting Methane (CH₄) Measurement

Prepare the calibration gases required to create the reference condition for the adjustment, and the setup for controlled calibration gas feed to the probe.



When making a 2-point adjustment, first carry out the zero signal adjustment in the **Zero point adjustment** tab. The zero signal adjustment replaces the low end adjustment in a 2-point adjustment.

- ▶ 1. Reset any possible existing adjustments with the **Restore factory adjustment** button. This prevents earlier adjustments from having an effect on the current adjustment.
- 2. Insert your device in the reference environment.
- 3. Before starting the adjustment, make sure that your environmental compensation settings are correct for your present environment. You can review and change the settings for pressure and temperature compensation setpoints in the **Compensation setpoints** tab.
- 4. Wait for the measurement (shown in the graph) to stabilize fully.
- 5. When the measurement has stabilized, click the **Reference value, point 1** text box and enter the known CH₄ level of the calibration point. Press **ENTER** or click outside the text box when done.
- 6. Check that the measured value for point 1 is automatically inserted.
- 7. Check the difference between the reference and the measured value. Very large differences may be due to insufficient stabilization time or unsuitable calibration setup.
 - a. If you want to apply the adjustment you have made, select **Activate adjustment**.
 - b. To exit without taking the adjustment in use, select **Close**.
- 8. After completing the adjustment, update the information in the **Calibration Information** tab.

8.2.4 Calibrating and Adjusting Carbon Dioxide (CO₂) Measurement

Prepare the calibration gases required to create the reference condition for the adjustment, and the setup for controlled calibration gas feed to the probe.



When making a 2-point adjustment, first carry out the zero signal adjustment in the **Zero point adjustment** tab. The zero signal adjustment replaces the low end adjustment in a 2-point adjustment.

- ▶ 1. Reset any possible existing adjustments with the **Restore factory adjustment** button. This prevents earlier adjustments from having an effect on the current adjustment.
- 2. Insert your device in the reference environment.
- 3. Before starting the adjustment, make sure that your environmental compensation settings are correct for your present environment. You can review and change the settings for pressure and temperature compensation setpoints in the **Compensation setpoints** tab.
- 4. Wait for the measurement (shown in the graph) to stabilize fully.

5. When the measurement has stabilized, click the **Reference value, point 1** text box and enter the known CO₂ level of the calibration point. Press **ENTER** or click outside the text box when done.
6. Check that the measured value for point 1 is automatically inserted.
7. Check the difference between the reference and the measured value. Very large differences may be due to insufficient stabilization time or unsuitable calibration setup.
 - a. If you want to apply the adjustment you have made, select **Activate adjustment**.
 - b. To exit without taking the adjustment in use, select **Close**.
8. After completing the adjustment, update the information in the **Calibration Information** tab.

8.2.5 Calibrating and Adjusting Temperature Measurement

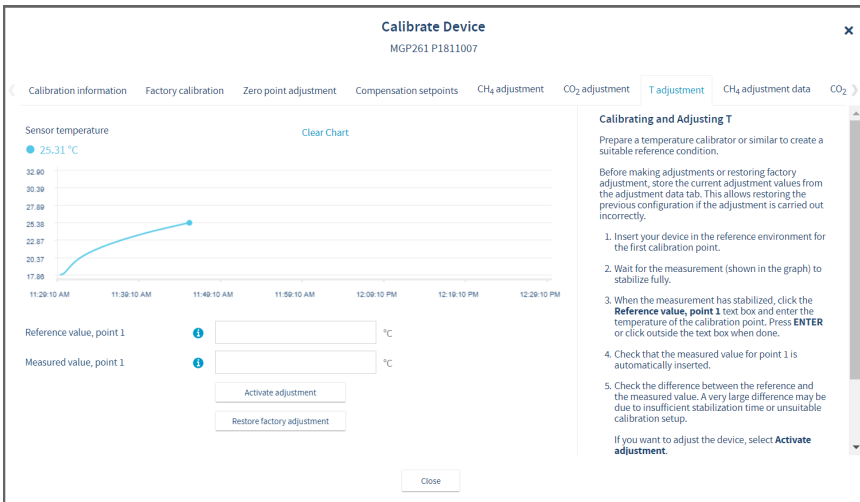

Figure 26 Temperature Adjustment View in Insight

Prepare a temperature calibrator or similar to create a suitable reference condition.



You can adjust temperature either in nitrogen or in air.

- ▶ 1. Insert your device in the reference environment.
2. Wait for the measurement (shown in the graph) to stabilize fully.

3. When the measurement has stabilized, click the **Reference value, point 1** text box and enter the known temperature of the calibration point. Press **ENTER** or click outside the text box when done.
4. Check that the measured value for point 1 is automatically inserted.
5. Check the difference between the reference and the measured value. Very large differences may be due to insufficient stabilization time or unsuitable calibration setup.
 - a. If you want to apply the adjustment you have made, select **Activate adjustment**.
 - b. To exit without taking the adjustment in use, select **Close**.
6. After completing the adjustment, update the information in the **Calibration Information** tab.

9. Maintenance

9.1 Filter Change

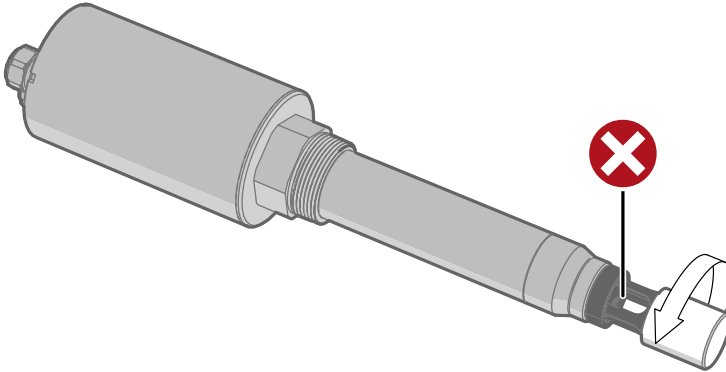

Figure 27 Replacing Filter

Replacement filters are available from Vaisala (order code: DRW249919SP). Remove the filter by rotating counter-clockwise.



CAUTION! Do not touch the optical surfaces inside the measurement cuvette when replacing the filter.



The probe filter is the only user-replaceable part in MGP261. For other maintenance requirements, contact Vaisala.

9.2 Removing Probe from Process



WARNING! When installed in situ, the surface of the probe is in direct contact with the biogas process. Bacteria, viruses, or fungi can be carried from the process on the probe surface.

- Always wear appropriate personal protective equipment when handling items that have been in contact with the biogas process. Follow local regulations and site-specific guidelines.
- Ensure the area where you place the probe after removing it from the process is suitable for working with items that have been in contact with the biogas process.



WARNING! While installing or uninstalling the device, there is a risk of flammable gas release or flame entrance.



WARNING! Exposure to hazardous gases (for example, hydrogen sulfide (H_2S)) is possible when installing or removing MGP261 from the process.

- Always follow local safety guidelines. Ensure that the work area is safe and meets local regulations (for example, related to ventilation and personal protective equipment).
- Use a personal gas detector to monitor the safety of the area you are working in.
- After installing or removing the probe, use a gas detector to ensure that process connections are leak-free.

- ▶ 1. Prepare an area where you can place the probe after removing it from the process.
 - a. Clear other items and equipment away from the area.
 - b. Cover surfaces around the area with protective material as necessary.
2. Switch off the probe power supply input.
3. If necessary, open the connection box and remove the wiring cables. See [Inserting Probe into Process and Opening Connection Box \(page 27\)](#).
 - a. Hold the probe in place by gripping the tightening nut with a wrench. Then open the connection box by turning the cover counter-clockwise with the connection box key.
 - b. Loosen the cable glands and pull the connection box open.
 - c. Open the screw terminals inside the connection box with a small screwdriver and remove the wiring cables.
 - d. Close the connection box.

4. Rotate the tightening nut of the probe counter-clockwise with a wrench to release the probe. See [Inserting Probe into Process and Opening Connection Box \(page 27\)](#).



CAUTION! The PTFE tape seal on the probe threads will tear when you rotate the probe open, and must be replaced when reinstalling the probe.

5. Pull the probe out of the process connection and place it on the area you prepared for handling the probe. Hold the probe from the connection box when handling it, and avoid touching the parts that have been inserted into the process.



Use a cloth or similar to prevent dripping when pulling out the probe.

6. **Ball valve installations only:** remove the safety pin that locks the handle of the ball valve in the open position and close the ball valve.
7. Clean the probe as instructed in [Cleaning the Probe \(page 60\)](#) and move the probe to a clean area for further handling.
8. When reinstalling the probe, repeat the installation steps starting from [Preparing Probe for Installation \(page 26\)](#).

9.3 Cleaning the Probe



WARNING! Removing the probe from the process can expose you to biological and chemical hazards due to the nature of the biogas process environment. Review the warnings and instructions listed in [Removing Probe from Process \(page 59\)](#).



- Moist cloth for wiping the probe
- Running water
- Standard cleaning agents can be used in cleaning

1. Prepare an area for cleaning the probe.
2. To remove the probe from process, follow the instructions in [Removing Probe from Process \(page 59\)](#).

- Clean the probe with running water and a cloth. Standard cleaning agents can be used.



CAUTION! Do not clean the probe with a pressure washer.



CAUTION! Do not immerse the probe in liquid to clean it.

- To install the probe back into the process after cleaning, follow the installation instructions starting from [Preparing Probe for Installation \(page 26\)](#).
- If you are sending the probe to Vaisala for maintenance, allow it to dry fully before packing it. See the instructions in [Sending Probe to Vaisala \(page 61\)](#).

9.4 Sending Probe to Vaisala

If you need to return the probe for maintenance or replacement, contact Vaisala technical support.



CAUTION! Do not ship the probe to Vaisala without contacting technical support. Technical support will provide you with return authorization and up-to-date shipping instructions.

- Read the warranty information.
- Contact Vaisala technical support and request a Return Material Authorization (RMA) and shipping instructions.



For information on product warranties, technical support, and repair services, see www.vaisala.com/support.



Always request the RMA before returning any material to Vaisala.

- Follow the return instructions received from Vaisala technical support. When packing the probe for shipping, ensure that you use sufficient padding, the probe has dried completely after cleaning, and that the probe is tightly sealed in a plastic bag.

10. Technical Data

10.1 Specifications

Table 7 Measurement Performance

Property	Methane CH ₄	Carbon Dioxide CO ₂	Water Vapor H ₂ O
Sensor	CARBOCAP®	CARBOCAP®	CARBOCAP®
Measurement unit	Volume-%	Volume-%	Volume-%, dew point °C
Measurement range	0 ... 100 vol-%	0 ... 100 vol-%	0 ... 25 vol-%, -10 ... +60 °C (14 ... +140 °F)
Accuracy specification at 25 °C (+77 °F) and 1013 mbar including non-linearity, calibration uncertainty, and repeatability; temperature and pressure compensated			
Accuracy at +25 °C (+77 °F) and 1013 mbar ¹⁾	<ul style="list-style-type: none"> • 0 ... 40 vol-%: ±2 vol-% • 40 ... 70 vol-%: ±1 vol-% • 70 ... 100 vol-%: ±2 vol-% 	<ul style="list-style-type: none"> • 0 ... 30 vol-%: ±2 vol-% • 30 ... 50 vol-%: ±1 vol-% • 50 ... 100 vol-%: ±2 vol-% 	0 ... 25 vol-%: ±0.5 vol-%
Repeatability	±0.5 vol-% at 60 vol-%	±0.3 vol-% at 40 vol-%	±0.1 vol-% at 10 vol-%
Temperature dependence	Compensated, 0 ... 100 vol-%: ±0.1 % of reading/°C	Compensated, 0 ... 100 vol-%: ±0.1 % of reading/°C	Compensated, 0 ... 25 vol-%: ±0.1 % of reading/°C
	Uncompensated, 0 ... 100 vol-%: -0.6 % of reading/°C	Uncompensated, 0 ... 100 vol-%: -0.2 % of reading/°C	Uncompensated, 0 ... 25 vol-%: -0.2 % of reading/°C
Pressure dependence	Compensated, 0 ... 100 vol-%: ±0.015 % of reading/mbar	Compensated, 0 ... 100 vol-%: ±0.01 % of reading/mbar	Compensated, 0 ... 25 vol-%: ±0.025 % of reading/mbar
	Uncompensated, 0 ... 100 vol-%: +0.2 % of reading/mbar	Uncompensated, 0 ... 100 vol-%: +0.2 % of reading/mbar	Uncompensated, 0 ... 25 vol-%: +0.15 % of reading/hPa
Long-term stability	±2 vol-%/year	±2 vol-%/year	±2 vol-%/year
Start-up time ²⁾	30 s		
Warm-up time ³⁾	2 min ⁴⁾		
Response time (T ₉₀)	90 s ⁵⁾		

Property	Methane CH ₄	Carbon Dioxide CO ₂	Water Vapor H ₂ O
Response time with flow-through adapter			90 s at ≥ 0.5 l/min ⁵⁾ (recommended: 0.5 ... 1 l/min)

- 1) *Excluding cross-interferences to other gases.*
- 2) *Time to first reading*
- 3) *Time to specified accuracy*
- 4) *At +20 °C (+68 °F) ambient temperature*
- 5) *With standard PTFE filter*

Table 8 Operating Environment

Property	Specification
Operating temperature range	-40 ... +60 °C (-40 ... +140 °F)
Operating humidity range	0 ... 100 %RH
Storage temperature range	-40 ... +60 °C (-40 ... +140 °F)
Storage humidity range	0 ... 90 %RH
Process pressure range	-500 ... +500 mbar(g)
Process temperature range	+0 ... +60 °C (+32 ... +140 °F)
Process flow range	0 ... 20 m/s ¹⁾

- 1) *A process flow range of 2 ... 20 m/s is suitable for in situ installations (probe installed directly into process). For process flow ranges between 0 ... 2 m/s, a flow-through installation is recommended.*

Table 9 Compliance

Property	Specification
Electromagnetic compatibility (EMC)	EN61326-1(2014), Industrial environment
Ex classification	Ex II 1/2 (I) G Ex eb mb [ia] IIB T3 Ga/Gb -40 °C ≤ Tamb ≤ +60 °C
IP rating	IP66

Table 10 Inputs and Outputs

Property	Specification
Operating voltage	18 ... 30 VDC
Power consumption	Typical: 3 W Maximum: 6 W

Property	Specification
Digital output	RS-485 (Modbus RTU)
Analog output	3 × 4 ... 20 mA scalable, isolated
Analog output load	Minimum: 20 Ω Maximum: 500 Ω
Analog output accuracy	±0.2 % of full scale at 25 °C (77 °F)
Analog output temperature dependence	0.005 %/°C (0.003 %/°F) full scale
Analog input (optional)	1 × 4 ... 20 mA (Ex ia) for external pressure or temperature sensor ¹⁾

1) *The optional analog input is galvanically isolated and provides power for the connected external pressure sensor.*

Table 11 Mechanical Specification

Property	Specification
Weight	2.5 kg (5.5 lb)
Thread type	1.5" male NPT
Cable lead-throughs	1 x M16x1.5 2 x M20x1.5
Materials	
Probe body	AISI316L stainless steel, PPS
Filter cap	Sintered PTFE

Table 12 Options and Accessories

Item	Order Code
Configuration cable (RS485/USB) ¹⁾	257295
Flow-through adapter	258877
Sintered PTFE filter (includes O-ring)	DRW249919SP
Connection box key	DRW250233SP
Shipping sleeve	ASM213114SP
NPT 1.5" thread test plug	257525SP

1) *Vaisala Insight software for Windows® available at www.vaisala.com/insight.*



10.2 Wetted Parts Material Information

Vaisala Oyj, as a manufacturer of the Vaisala CARBOCAP Multigas Probe MGP261, certifies that the materials used in the wetted parts of the MGP261 probe are the following:

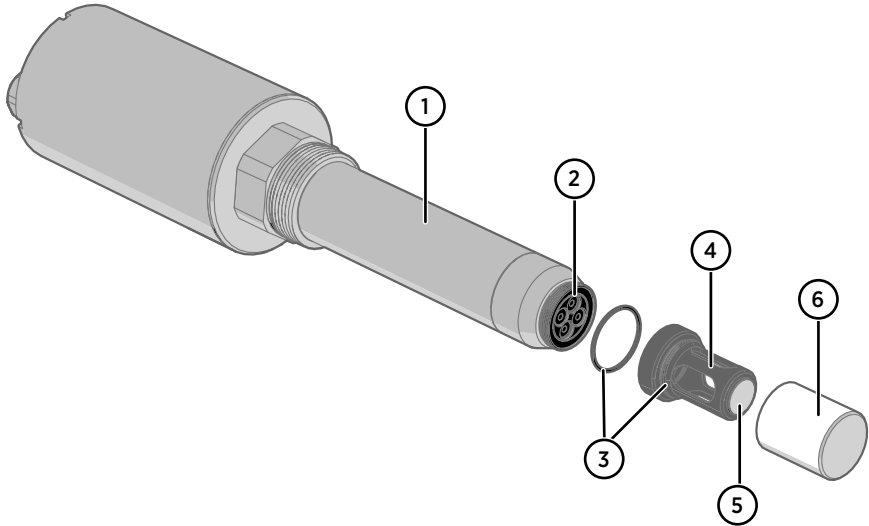

- 1 **Probe body:** AISI 316L, EN 1.4404 (X2CrNiMo17-12-2) (AISI 316L)
- 2 **Sensor package window:** polished sapphire
- 3 **O-ring:** ethylene-propylene rubber, black
- 4 **Measurement cuvette:** PPS GF40 (polyphenylene sulfide, 40 % glass fibers, black)
- 5 **Infrared measurement mirror:** Optical borosilicate glass, class BK7
- 6 **Filter cap:** PTFE (polytetrafluoroethylene, porous/solid structure)

10.4 Flow-Through Adapter Dimensions

Figure 29 (page 67) shows the dimensions of the MGP261 flow-through adapter 258877 with MGP261 installed into the adapter. The dimension figure also shows the measurement (from the edge of the adapter mounting plate to the edge of the connection box) that can be used to verify that the probe has been inserted to correct installation depth. The dimensions are given in millimeters and [inches].

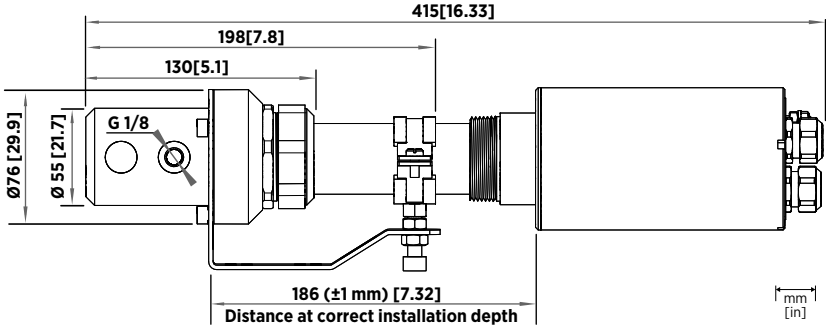

Figure 29 Flow-Through Adapter Dimensions with MGP261 Probe

Figure 30 (page 67) shows the dimensions and screw hole sizes of the flow-through adapter mounting plate.

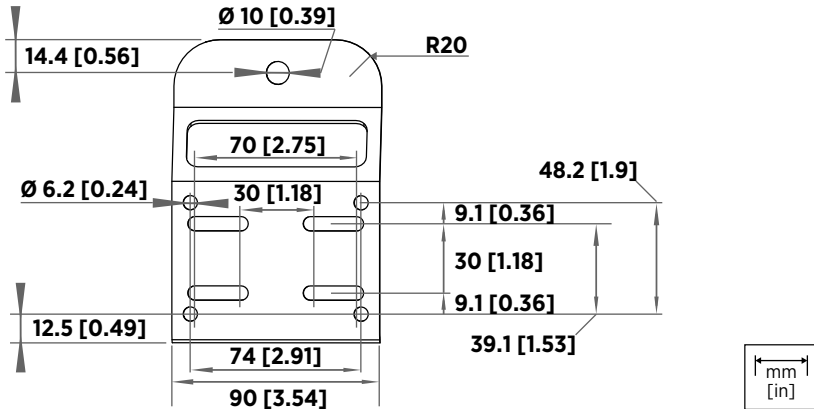

Figure 30 Flow-Through Adapter Mounting Plate Dimensions

Appendix A. Modbus Registers

A.1 Modbus Registers



CAUTION! Registers are numbered in decimal, starting from one. Register addresses in actual Modbus messages (Modbus Protocol Data Unit (PDU) are in hexadecimal and start from zero. Subtract 1 from the register number presented in this manual to get the address used in the Modbus message. For example, the register number 769 (Modbus address) corresponds to address 0300_{hex} in the Modbus message.

Accessing unavailable (temporarily missing) measurement data does not generate an exception. "Unavailable" value (a quiet NaN for floating point data or 0000_{hex} for integer data) is returned instead. An exception is generated only for any access outside the applicable register ranges.

A.1.1 Measurement Data

Table 13 Modbus Measurement Data Registers (Read-Only)

Register Number (Decimal)	Address (Hexadecimal)	Register Description	Data Format	Unit
Floating Point Values				
1	0000 _{hex}	Methane (CH ₄) concentration	32-bit float	ppm _v
	0001 _{hex}			
3	0002 _{hex}	Methane (CH ₄) concentration, dry basis	32-bit float	ppm _v
	0003 _{hex}			
5	0004 _{hex}	Carbon dioxide (CO ₂) concentration	32-bit float	ppm _v
	0005 _{hex}			
7	0006 _{hex}	Carbon dioxide (CO ₂) concentration, dry basis	32-bit float	ppm _v
	0007 _{hex}			
9	0008 _{hex}	Water (H ₂ O) concentration	32-bit float	ppm _v
	0009 _{hex}			
11	000A _{hex}	Water (H ₂ O) concentration, dry basis	32-bit float	ppm _v
	000B _{hex}			

Register Number (Decimal)	Address (Hexadecimal)	Register Description	Data Format	Unit
Floating Point Values				
13	000C _{hex}	Dew point temperature	32-bit float	T _d °C
	000D _{hex}			
15	000E _{hex}	Dew / frost point temperature	32-bit float	T _{df} °C
	000F _{hex}			
17	0010 _{hex}	Sensor temperature	32-bit float	Ts °C
	0011 _{hex}			
Integer values				
257	0100 _{hex}	Methane (CH ₄) concentration	16-bit integer	ppm _v / 100 (parts per ten thousand)
258	0101 _{hex}	Methane (CH ₄) concentration, dry basis	16-bit integer	ppm _v / 100 (parts per ten thousand)
259	0102 _{hex}	Carbon dioxide (CO ₂) concentration	16-bit integer	ppm _v / 100 (parts per ten thousand)
260	0103 _{hex}	Carbon dioxide (CO ₂) concentration, dry basis	16-bit integer	ppm _v / 100 (parts per ten thousand)
261	0104 _{hex}	Water (H ₂ O) concentration	16-bit integer	ppm _v / 100 (parts per ten thousand)
262	0105 _{hex}	Water (H ₂ O) concentration, dry basis	16-bit integer	ppm _v / 100 (parts per ten thousand)
263	0106 _{hex}	Dew point temperature	16-bit integer (× 10)	T _{df} °C T _{df} °F
264	0107 _{hex}	Dew / frost point temperature	16-bit integer (× 10)	T _{df} °C T _{df} °F

A.1.2 Configuration Registers

Table 14 Modbus Configuration Data Registers (Writable)

Register Number (Decimal)	Address (Hexadecimal)	Register Description	Data Format	Unit / Valid Range
Environmental Compensation				
769	0300 _{hex}	Power-up value for pressure compensation	32-bit float	hPa Range: 450 ... 1550 Init/default: 1013.25
771	0302 _{hex}	Power-up value for temperature compensation	32-bit float	°C Range: -10 ... 70 Init/default: 25
773	0304 _{hex}	Volatile pressure compensation (value cleared at probe reset)	32-bit float	hPa Range 450 ... 1550 hPa Init/default: 1013.25
775	0306 _{hex}	Volatile temperature compensation (value cleared at probe reset)	32-bit float	°C Range: -10 ... 70 Init/default: 25
Function Control				
1281	0500 _{hex}	Pressure compensation mode selection	Enum	0 = Off 1 = Setpoint 2 = External
1282	0501 _{hex}	Temperature compensation mode selection	Enum	0 = Off 1 = Setpoint 2 = Measured 3 = External
1283	0502 _{hex}	Installation type selection	Enum	0 = Directly in process 1 = Flow-through adapter
Communication				
1537	0600 _{hex}	Serial address	16-bit integer	Valid range 1 ... 255 Default: 240

Communication				
1538	0601 _{hex}	Bit rate	Enum	Valid range 4800 ... 115200 4 = 4800 5 = 9600 6 = 19200 7 = 38400 8 = 57600 9 = 115200 (default: 6 (19200))
1539	0602 _{hex}	Parity, data, stop bits	Enum	0 = N,8,1 1 = N,8,2 2 = E,8,1 3 = E,8,2 4 = O,8,1 5 = O,8,2
1540	0603 _{hex}	Response delay	16-bit integer	Valid range 0 ... 1000
1541	0604 _{hex}	Restart device	Function	
Analog Output 1				
1794	0701 _{hex}	Analog output 1 measurement parameter selection. When written, scalings are reset.	Reg	0000 _{hex} (CH ₄ wet basis) 0002 _{hex} (CH ₄ dry basis) 0004 _{hex} (CO ₂ wet basis) 0006 _{hex} (CO ₂ dry basis) 0008 _{hex} (H ₂ O wet basis) 000A _{hex} (H ₂ O dry basis) 000C _{hex} (T _d) 000E _{hex} (T _{df}) See Table 13 (page 68)

Analog Output 1				
1795	0702 _{hex}	Scale low end for analog output 1 measurement parameter. Minimum and maximum values vary for different parameters.	Float	<p>Output parameters</p> <p>0000_{hex} (CH₄ wet basis)</p> <p>0002_{hex} (CH₄ dry basis)</p> <p>0004_{hex} (CO₂ wet basis)</p> <p>0006_{hex} (CO₂ dry basis):</p> <p>Minimum: 0</p> <p>Maximum: 1000000</p> <hr/> <p>Output parameters</p> <p>0008_{hex} (H₂O wet basis)</p> <p>000A_{hex} (H₂O dry basis):</p> <p>Minimum: 0</p> <p>Maximum: 250000</p> <hr/> <p>Output parameters</p> <p>000C_{hex} (T_d)</p> <p>000E_{hex} (T_{df}):</p> <p>Minimum: -10</p> <p>Maximum: 60</p>

Analog Output 1				
1797	0704 _{hex}	Scale high end for analog output 1 measurement parameter. Minimum and maximum values vary for different parameters.	Float	Output parameters 0000 _{hex} (CH ₄ wet basis) 0002 _{hex} (CH ₄ dry basis) 0004 _{hex} (CO ₂ wet basis) 0006 _{hex} (CO ₂ dry basis): Minimum: 0 Maximum: 1000000
				Output parameters 0008 _{hex} (H ₂ O wet basis) 000A _{hex} (H ₂ O dry basis): Minimum: 0 Maximum: 250000
				Output parameters 000C _{hex} (T _d) 000E _{hex} (T _{df}): Minimum: -10 Maximum: 60
1799	0706 _{hex}	Error output level (mA)	Float	Min. 0.5 mA Max. 24 mA

Analog Output 2				
2050	0801 _{hex}	Analog output 2 measurement parameter selection. When written, scalings are reset.	Reg	0000 _{hex} (CH ₄ wet basis) 0002 _{hex} (CH ₄ dry basis) 0004 _{hex} (CO ₂ wet basis) 0006 _{hex} (CO ₂ dry basis) 0008 _{hex} (H ₂ O wet basis) 000A _{hex} (H ₂ O dry basis) 000C _{hex} (T _d) 000E _{hex} (T _{df}) See Table 13 (page 68)

Analog Output 2				
2051	0802 _{hex}	Scale low end for analog output 2 measurement parameter. Minimum and maximum values vary for different parameters.	Float	<p>Output parameters</p> <p>0000_{hex} (CH₄ wet basis)</p> <p>0002_{hex} (CH₄ dry basis)</p> <p>0004_{hex} (CO₂ wet basis)</p> <p>0006_{hex} (CO₂ dry basis):</p> <p>Minimum: 0</p> <p>Maximum: 1000000</p>
				<p>Output parameters</p> <p>0008_{hex} (H₂O wet basis)</p> <p>000A_{hex} (H₂O dry basis):</p> <p>Minimum: 0</p> <p>Maximum: 250000</p>
				<p>Output parameters</p> <p>000C_{hex} (T_d)</p> <p>000E_{hex} (T_{df}):</p> <p>Minimum: -10</p> <p>Maximum: 60</p>

Analog Output 2				
2053	0804 _{hex}	Scale high end for analog output 2 measurement parameter. Minimum and maximum values vary for different parameters.	Float	Output parameters 0000 _{hex} (CH ₄ wet basis) 0002 _{hex} (CH ₄ dry basis) 0004 _{hex} (CO ₂ wet basis) 0006 _{hex} (CO ₂ dry basis): Minimum: 0 Maximum: 1000000
				Output parameters 0008 _{hex} (H ₂ O wet basis) 000A _{hex} (H ₂ O dry basis): Minimum: 0 Maximum: 250000
				Output parameters 000C _{hex} (T _d) 000E _{hex} (T _{df}): Minimum: -10 Maximum: 60
2055	0806 _{hex}	Error output level (mA)	Float	Min. 0.5 mA Max. 24 mA

Analog Output 3				
2306	0901 _{hex}	Analog output 3 measurement parameter selection. When written, scalings are reset.	Reg	0000 _{hex} (CH ₄ wet basis) 0002 _{hex} (CH ₄ dry basis) 0004 _{hex} (CO ₂ wet basis) 0006 _{hex} (CO ₂ dry basis) 0008 _{hex} (H ₂ O wet basis) 000A _{hex} (H ₂ O dry basis) 000C _{hex} (T _d) 000E _{hex} (T _{df}) See Table 13 (page 68)

Analog Output 3				
2307	0902 _{hex}	<p>Scale low end for analog output 3 measurement parameter.</p> <p>Minimum and maximum values vary for different parameters.</p>	Float	<p>Output parameters</p> <p>0000_{hex} (CH₄ wet basis)</p> <p>0002_{hex} (CH₄ dry basis)</p> <p>0004_{hex} (CO₂ wet basis)</p> <p>0006_{hex} (CO₂ dry basis):</p> <p>Minimum: 0</p> <p>Maximum: 1000000</p> <hr/> <p>Output parameters</p> <p>0008_{hex} (H₂O wet basis)</p> <p>000A_{hex} (H₂O dry basis):</p> <p>Minimum: 0</p> <p>Maximum: 250000</p> <hr/> <p>Output parameters</p> <p>000C_{hex} (T_d)</p> <p>000E_{hex} (T_{df}):</p> <p>Minimum: -10</p> <p>Maximum: 60</p>

Analog Output 3				
2309	0904 _{hex}	Scale high end for analog output 3 measurement parameter. Minimum and maximum values vary for different parameters.	Float	Output parameters 0000 _{hex} (CH ₄ wet basis) 0002 _{hex} (CH ₄ dry basis) 0004 _{hex} (CO ₂ wet basis) 0006 _{hex} (CO ₂ dry basis): Minimum: 0 Maximum: 1000000
				Output parameters 0008 _{hex} (H ₂ O wet basis) 000A _{hex} (H ₂ O dry basis): Minimum: 0 Maximum: 250000
				Output parameters 000C _{hex} (T _d) 000E _{hex} (T _{df}): Minimum: -10 Maximum: 60
2311	0906 _{hex}	Error output level (mA)	Float	Min. 0.5 mA Max. 24 mA
Analog Input 1				
2562	0A01 _{hex}	Analog input 1 compensation parameter. Read-only: controlled by the pressure and temperature compensation mode registers.	Reg	0204 _{hex} (pressure) 0206 _{hex} (temperature)

Analog Input 1				
2563	0A02 _{hex}	Scale low end for analog input 1 compensation parameter. Minimum and maximum values vary for different parameters.	Float	0204 _{hex} (pressure) Minimum: 0 Maximum: 20 000
				0206 _{hex} (temperature) Minimum: -200 Maximum: 400
2565	0A04 _{hex}	Scale high end for analog input 1 compensation parameter. Minimum and maximum values vary for different parameters.	Float	0204 _{hex} (pressure) Minimum: 0 Maximum: 20 000
				0206 _{hex} (temperature) Minimum: -200 Maximum: 400
2567	0A06 _{hex}	Input value (read-only)	Float	

A.1.3 Status Registers

Table 15 Modbus Status Data Registers (Read-Only)

Register Number (Decimal)	Address (Hexadecimal)	Register Description	Data Format	Bitmask
513	0200 _{hex}	Error code	32-bit signed integer	0201 _{hex} (status code low): see Table 16 (page 81) .
	0202 _{hex}			0202 _{hex} (status code high): see Table 17 (page 82) .
517	0204 _{hex}	Pressure compensation values in use	Float	
519	0206 _{hex}	Temperature compensation values in use	Float	

Register Number (Decimal)	Address (Hexadecimal)	Register Description	Data Format	Bitmask
521	0208 _{hex}	CH ₄ measurement status	16-bit signed integer	0000_{hex} : Unsupported 0001_{hex} : Reading is not reliable 0002_{hex} : Under range 0003_{hex} : Over range 0004_{hex} : Noisy 0005_{hex} : Value locked 0006_{hex} : Calibration expired 0007_{hex} : Sensor failure 0008_{hex} : Measurement not ready
522	0209 _{hex}	CH ₄ measurement status (dry basis)	16-bit signed integer	
523	020A _{hex}	CO ₂ measurement status	16-bit signed integer	
524	020B _{hex}	CO ₂ measurement status (dry basis)	16-bit signed integer	
525	020C _{hex}	H ₂ O measurement status	16-bit signed integer	
526	020D _{hex}	T _{df} measurement status	16-bit signed integer	
527	020E _{hex}	T _s measurement status	16-bit signed integer	
528	020F _{hex}	Device status	16-bit signed integer	0000_{hex} : Critical failure 0001_{hex} : Error 0002_{hex} : Warning 0003_{hex} : Notification
529	0210 _{hex}	Clear error log: the error log is cleared if 1 is written, other values are ignored. Register always reads as 0.	Function	

Table 16 Error Codes in Register 0200_{hex} (Status Code Low)

Bitmask	Error Message	Severity
0000 _{hex}	Firmware checksum mismatch.	Critical
0001 _{hex}	Device settings corrupted.	Critical
0009 _{hex}	Infrared source temperature too high.	Error
0010 _{hex}	Infrared source failure.	Error
0011 _{hex}	Infrared source failure.	Error
0012 _{hex}	Supply voltage out of range.	Error
0013 _{hex}	Internal voltage out of range.	Error

Bitmask	Error Message	Severity
0014 _{hex}	Sensor signal low.	Error
0015 _{hex}	Sensor signal low.	Error
0016 _{hex}	Internal voltage out of range.	Error
0017 _{hex}	Sensor signal distorted.	Error
0018 _{hex}	Sensor signal distorted.	Error
0019 _{hex}	CH ₄ measurement out of range.	Error
0020 _{hex}	CO ₂ measurement out of range.	Error
0021 _{hex}	H ₂ O measurement out of range.	Error
0022 _{hex}	T _d measurement out of range.	Error
0023 _{hex}	Sensor heater failure.	Error
0024 _{hex}	Infrared source temperature too high.	Error
0025 _{hex}	Internal temperature too high.	Error
0026 _{hex}	Temperature measurement error.	Error
0027 _{hex}	Supply power insufficient for analog input.	Error
0028 _{hex}	Analog input 1 out of range.	Error
0030 _{hex}	Internal temperature error.	Error
0031 _{hex}	Supply power insufficient for operation.	Error

Table 17 Error Codes in Register 0202_{hex} (Status Code High)

Bitmask	Error Message	Severity
0032 _{hex}	Sensor signal low.	Warning
0033 _{hex}	Sensor signal low.	Warning
0034 _{hex}	Internal temperature high.	Warning
0035 _{hex}	Sensor signal distorted.	Warning
0036 _{hex}	Sensor signal distorted.	Warning
0037 _{hex}	Sensor signal distorted.	Warning
0038 _{hex}	Unexpected device restart.	Warning
0039 _{hex}	Calibration has expired.	Warning
0042 _{hex}	Infrared source temperature out of range.	Warning

Bitmask	Error Message	Severity
0043 _{hex}	Supply power insufficient for analog input.	Warning
0044 _{hex}	Infrared source temperature out of range.	Warning
0048 _{hex}	Heater off.	Info
0049 _{hex}	Calibration is about to expire.	Info

A.1.4 Device Identification Objects

Table 18 Device Identification Objects

Object ID (Decimal)	Object ID (Hexadecimal)	Object Name	Example Contents
0	00 _{hex}	VendorName	"Vaisala"
1	01 _{hex}	ProductCode	"MGP261 "
2	02 _{hex}	MajorMinorVersion	Software version (for example "1.2.3")
3	03 _{hex}	VendorUrl	"http://www.vaisala.com/"
4	04 _{hex}	ProductName	"Vaisala Multigas Probe MGP261 "
128	80 _{hex}	SerialNumber ¹⁾	Probe serial number (for example, "R0710040")
129	81 _{hex}	Calibration date ¹⁾	Date of the factory calibration
130	82 _{hex}	Calibration text ¹⁾	Information text of the factory calibration

1) *Vaisala-specific device information object*

Warranty

For standard warranty terms and conditions, see www.vaisala.com/warranty.

Please observe that any such warranty may not be valid in case of damage due to normal wear and tear, exceptional operating conditions, negligent handling or installation, or unauthorized modifications. Please see the applicable supply contract or Conditions of Sale for details of the warranty for each product.

Technical Support



Contact Vaisala technical support at helpdesk@vaisala.com. Provide at least the following supporting information:

- Product name, model, and serial number
- Name and location of the installation site
- Name and contact information of a technical person who can provide further information on the problem

For more information, see www.vaisala.com/support.

Recycling



Recycle all applicable material.



Follow the statutory regulations for disposing of the product and packaging.

VAISALA

www.vaisala.com

