

OPERATOR'S MANUAL FORKLIFT TRUCK

MODELS 1F1/1F2



- It is the responsibility of the Operator and Supervisor to read and understand this manual.
- Protect the earth and be kind to your lift truck.

UniCarriers Corporation

A Word to UniCarriers FORKLIFT Operators

This ORIGINAL OPERATORS MANUAL describes operating procedures, daily checks and simple maintenance for safe usage of your UniCarriers FORKLIFT. We urge you to read this ORIGINAL OPERATORS MANUAL carefully before operating a UniCarriers FORKLIFT to familiarize yourself with the safety instructions. An operator of any industrial truck should maintain safety as the number one priority at all times. These instructions will not only reduce mechanical issues with a forklift, but may also save a life.

If you encounter any problems with a UniCarriers FORKLIFT, contact an authorized UniCarriers FORKLIFT dealer in your area and request a complete checkup. The dealership will ensure that your forklift is serviced in accordance with the latest factory approved methods. This ORIGINAL OPERATORS MANUAL is not a training manual, it is a guide to help trained and authorized operators safely operate this forklift. Please consult your employer for proper training on the appropriate use of this forklift while performing your job. Illustrations in this ORIGINAL OPERATORS MANUAL will show the operator the correct procedures for checking, starting, operating and stopping this forklift.

All information, specifications and illustrations in this ORIGINAL OPERATORS MANUAL are based on the latest data obtainable at the time of publication. UniCarriers Corporation reserves the right to make changes or improvements at any time without notice.

This ORIGINAL OPERATORS MANUAL has been prepared on the assumption that your forklift is fully equipped (including all optional equipment). Thus, if you have any questions regarding equipment, please contact an authorized UniCarriers FORKLIFT dealer.

©2015 UniCarriers Corporation

UniCarriers Corporation

1-2, Shin-Ogura, Saiwai-ku,
Kawasaki, Kanagawa,
212-0031, Japan

Dear Owner of a UniCarriers Truck:

Original Instruction Manual

The Original Instruction Manual contains information that You, as user of the truck, must be aware of in order to avoid/minimise the risk of injury/damage to yourself and the truck. You are also responsible to the company management, other people and objects in your environment. You should therefore read through this manual before starting the truck for the first time.

Our products are constantly being developed and renewed, we therefore reserve the right to make alterations without prior notice.

Thank you for choosing **UniCarriers Corporation** as your truck supplier.

UniCarriers Corporation service



As the owner of a UniCarriers truck, we also welcome you to our service organisation.

We offer support and advice for any problems that may arise and assistance with servicing and ordering of replacement parts. Refer to the nearest authorised sales agent or service workshop for assistance.

Truck driving courses

The importance of goods handling for the company and the environment increases every year, at the same time ever more technical solutions are developed and introduced on our trucks. It is therefore important that the driver, who has a key role to play in goods handling, is given the correct conditions to operate as safely and efficiently as possible. Statistics show that the number of incidents decreases significantly when a truck driver has been properly trained. Please contact us for information about the training package.

Throughout this manual we have used the symbol:

-  followed by the word **WARNING**. This is used to indicate the presence of a hazard which may cause the possibility of a personal injury or other damage and must be followed precisely.
-  **CAUTION**. This is also used throughout the manual to indicate the presence of a hazard that could cause possible injury to yourself or components and the procedures must be followed carefully.

It should be kept in mind that this ORIGINAL OPERATORS MANUAL deals with both standard and optional equipment, and so you may come across issues that are not applicable to your model in particular.

TRUCK MODIFICATION

NOTE:

Unauthorized forklift modification is not permitted.

No modifications or alterations to a powered industrial forklift, which may affect, for example, capacity, stability or safety requirements of the forklift shall be made without the prior written approval of UniCarriers FORKLIFT, its authorized representative or a successor thereof.

Contact an authorized UniCarriers FORKLIFT dealer before making any modification or alteration to your industrial forklift that may affect, for example, braking, steering, visibility and the addition of removable attachments.

After receiving the approval of UniCarriers FORKLIFT, its authorized representative or a successor thereof, the capacity plate, decals tags, operation and maintenance handbooks shall also be changed appropriately.

Only in the event that UniCarriers FORKLIFT is no longer in business and there is no successor in the interest to the business, the user may arrange for a modification or alteration to a powered industrial forklift, provided however, that the user shall:

- A. Arrange for the modification or alteration to be designed, tested and implemented by an engineer(s) expert in industrial forklifts for their safety;
- B. Maintain a permanent record of the design, test(s) and implementation of the modification or alteration;
- C. Approve and make appropriate changes to the capacity plate(s), decals, tags and instruction handbook;
- D. Affix a permanent and easily visible label to the forklift stating the manner in which the forklift has been modified or altered together with the date of the modification or alteration, and the name and address of the organization that performed the alterations.

Contents

To Operators	1	Switches and controls	37
TRUCK modification	3	Starting and operating	47
Name of components	5	Loading and unloading	61
Operator's qualifications and protective equipment for operating forklift	5	Function tests	63
Safety rules	6	SEAT (except for EU region)	65
Traveling on gradients, gangways and in elevators	10	Seat (for EU region)	68
Transporting forklift	12	Top panel lock	72
Approach angle, departure angle and gangway	12	Daily care and inspection	80
Special operating conditions	14	Maintenance	91
Installation of attachments	14	Maintenance schedule	105
Position of labels	14	Putting forklift in storage	108
Instruments and controls	20	Daily checks	110
Changing meter display	21	UniCarriers FORKLIFT genuine parts	110
Selector lever position	24	Disposal of parts and materials	111
Setting the time	25	Precautions for using LPG model	111
Setting the date	26	Periodic maintenance schedule	125
Explanation of warning lamps	28	Identification numbers	129
LCD warning symbols	29	Diesel particle filter [DPF] (option for diesel forklift only)	131
Inspection timing display	30	Specifications	139
Displays when malfunction occurs	30	Noise level	153
LPG remaining time management	34	Index	156

NAME OF COMPONENTS

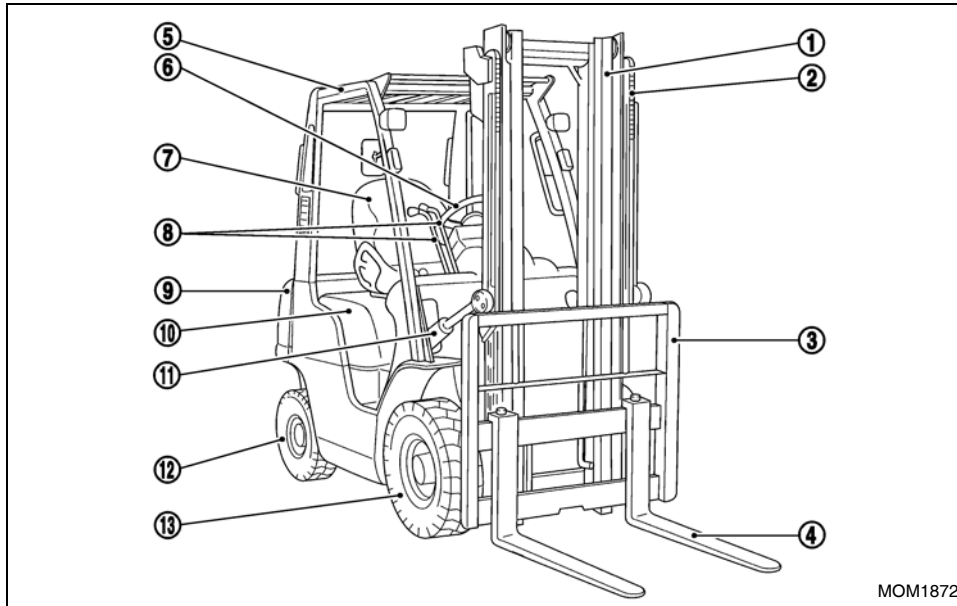

- ① Mast
- ② Lift chain
- ③ Backrest
- ④ Fork
- ⑤ Overhead guard
- ⑥ Steering wheel
- ⑦ Operator's seat
- ⑧ Control lever
- ⑨ Counterweight

- ⑩ Top panel
- ⑪ Tilt cylinder
- ⑫ Rear tire
- ⑬ Front tire

OPERATOR'S QUALIFICATIONS AND PROTECTIVE EQUIPMENT FOR OPERATING FORKLIFT

OPERATOR'S QUALIFICATIONS



The forklift shall be operated in accordance with the operations of the operator's license and the applicable provisions of the local laws and regulations.

SAFETY RULES

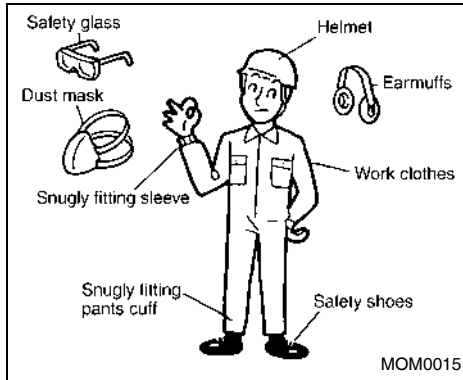

PERSONAL PROTECTIVE EQUIPMENT FOR OPERATING FORKLIFT

WARNING:

- For operation of the forklift, the protective equipment for the operator shall be dependent upon the conditions of use and the applicable provisions of the local laws and regulations.
- The working clothes worn by the operator shall be such that sleeves and cuffs fit snugly so as to prevent them from getting caught on forklift levers, etc., and safety glasses, earmuffs, dust mask and safety shoes should also be worn, as required by the work environment or employer.



- ⚠ Operator must be trained and authorized to drive the forklift and must understand safety techniques and rules for forklift operation.
- ⚠ Inspect the forklift before operating. Do not operate the forklift if it is in need of repair. If it is in need of repair, tag the forklift, remove the key and report the condition to the proper authority. Do not attempt repair unless you are trained and authorized to perform repairs.
- ⚠ Do not remove the overhead guard or backrest.

⚠ Make sure that the selector lever is set in neutral and the parking brake is applied before turning the ignition switch. Do not start or operate the forklift if you are not in the designated operator's position.

⚠ Do not allow anyone on any part of the forklift while moving or lifting.

⚠ Do not sit on the fork (when loaded or not) or get under the fork.

⚠ Before operation, make sure that the seat belt is secure and the top panel latch is in the locked position.

⚠ Before starting the engine, make sure that the seat belt is secure.

⚠ 1F1/1F2 models do not have the creeping phenomena.

⚠ The forklift will not move if the selector lever is in the F (forward) or R (reverse) position unless you depress the accelerator pedal. When depressing the accelerator pedal, be sure to visually confirm the position of the selector lever. When starting on slopes, be sure to apply the parking brake to hold the forklift and then start, even if the slopes are gentle. Avoid rapid acceleration (especially when carrying a high load).

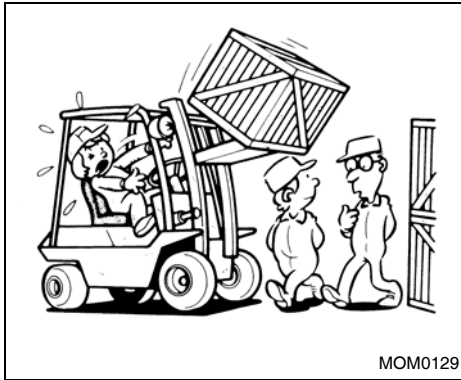

! Keep hands, feet and other parts of your body inside the operator's compartment at all times.

! Do not allow anyone to stand or walk under the elevated portion of the forklift whether it is empty or loaded.

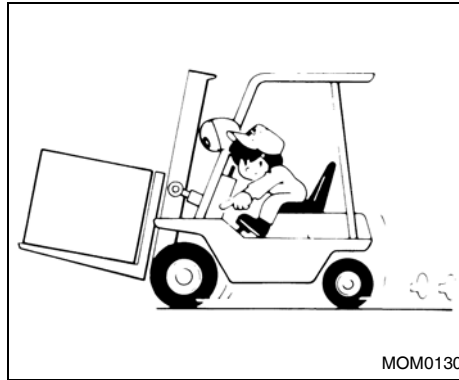

! Space forks as far apart as the load will permit.

! Always carry loads low with the mast tilted to the backmost position, never forward. Do not elevate loads except during stacking.

! Maintain a careful lookout for people and obstructions, and watch the path of travel. Watch clearances, especially overhead and tail swing. When visibility is obstructed, use extreme caution. Yield the right of way to pedestrians.

! If the load obstructs the front view, drive the forklift in reverse.



! Do not place a load higher than the backrest of the forklift. A load placed higher than the backrest may drop towards the operator and is very dangerous. If such a load must be handled, securely fasten the load using suitable ropes or hold-down bands.

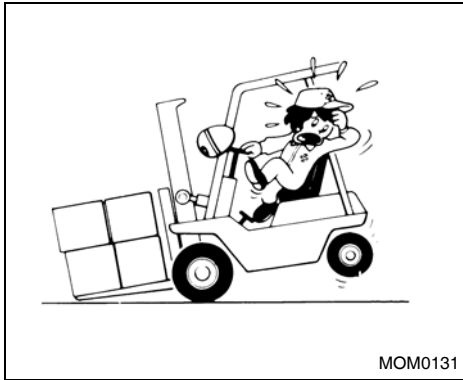

! Do not overload the forklift. Check the load chart for load weight and load center information. Always pick up loads as close to the center of the weight as possible to avoid off-center loading.

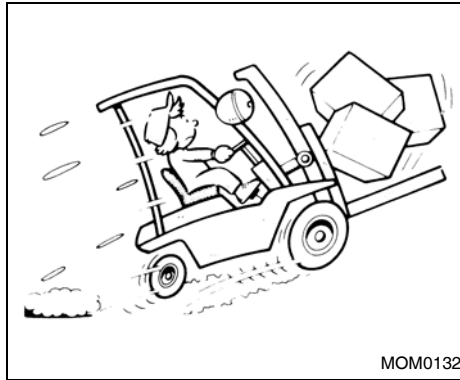

! Avoid sudden starts, stops or turns. Slow down for turns and on uneven or slippery surfaces that could cause the forklift to overturn or slide.

! Use special care when traveling without a load as the risk of lateral overturn may be greater than when traveling with a load.

! Before entering forklifts or trailers, be certain that the brakes on the forklift or trailer are applied and the wheel chocks are in place or that the trailer is locked to the loading dock.

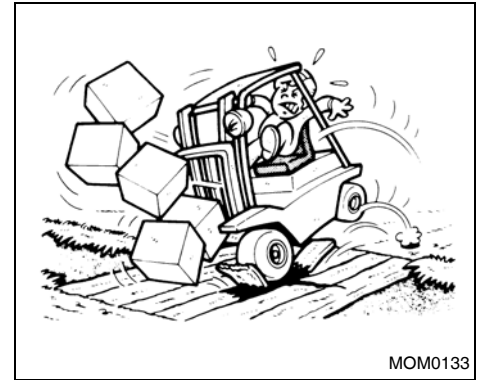

! Before driving over a dockboard or bridge plate, be certain that it is properly secured. Drive carefully and slowly across the dockboard or bridge plate. Never exceed its rated capacity.

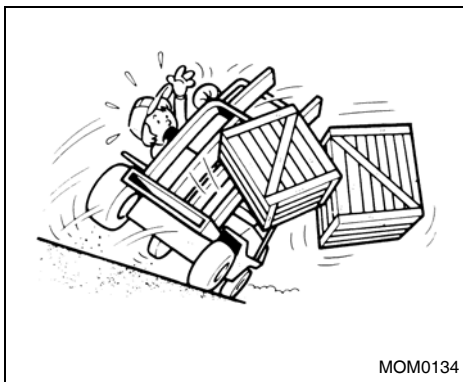

! Use special care when operating on slopes. Travel slowly and do not angle across or turn.

! Do not handle unstable or loosely stacked loads. When handling long, high or wide loads, use special care to ensure stability and carefully watch the surrounding conditions.

! When approaching cross aisles, slow down and sound the horn if visibility is obstructed.

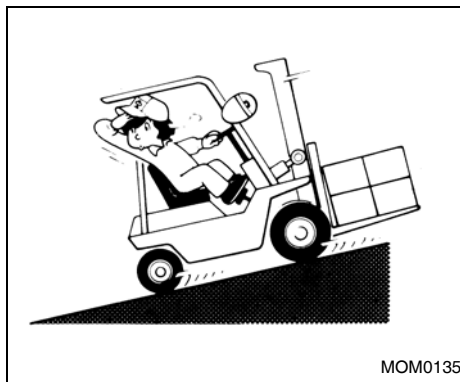

! When ascending or descending slopes, drive the forklift with the load facing up grade.

! Before leaving the forklift, be sure that forks or attachments are lowered, the selector lever is in neutral, the hand brake is applied and the ignition switch is turned off. Avoid parking the forklift on a slope.

! Fuel is highly flammable. It must be handled with the utmost care, in accordance with the safe handling requirements of fuels and the applicable safety provisions of the local laws and regulations. When filling the tank with fuel, make sure that the forklift is properly parked. Turn off the ignition switch and remove the key. When fuel is spilled, wipe the area clean with a cloth. The cloth shall be disposed of in accordance with the requirements of safe handling of fuels, environmental requirements and the applicable provisions of the local laws and regulations.

TRAVELING ON GRADIENTS, GANGWAYS AND IN ELEVATORS

WARNING:

- When moving the forklift in elevators, check to make sure that the elevator is capable of withstanding the forklift weight or the forklift weight plus the load weight.
- Be sure to apply chocks under the tires to prevent the forklift from moving while it is parked in the elevator.
- Do not perform work in the elevator.

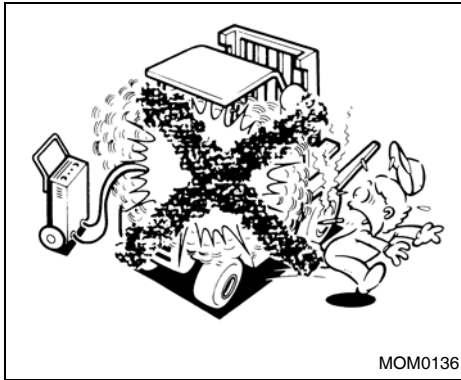

 When filling the tank with fuel or recharging the battery, stop the engine and place the forklift only in a designated area with good ventilation. Keep away from arcs, sparks, flames or lit cigarettes.

 Do not breathe exhaust gases: they contain colorless and odorless carbon monoxide. Carbon monoxide is a dangerous gas and can cause unconsciousness or death.

 Do not run the engine in closed spaces or poorly ventilated rooms such as a garage or refrigerator, etc.

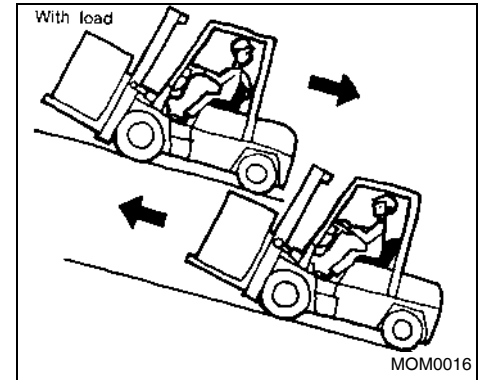

WARNING:

Use care when traveling on gradients.

- When traveling on gradients with a load, always drive forward on upward slopes and in reverse on downward slopes.
- Drive slowly on slopes. Drive in the reverse direction on upward slopes when without a load, and drive forward on downward slopes.

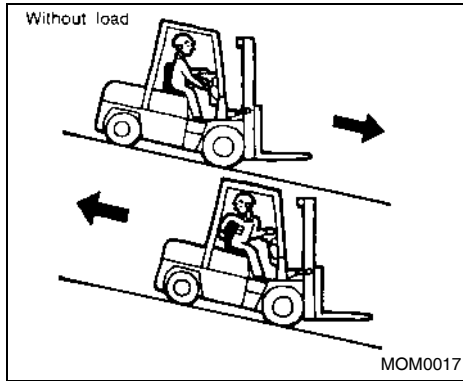

- Use the brake pedal when driving downhill to sufficiently reduce the speed.

- ⚠ Use the brake pedal and engine brake together when driving downhill so as to maximize the effectiveness of the engine brake.

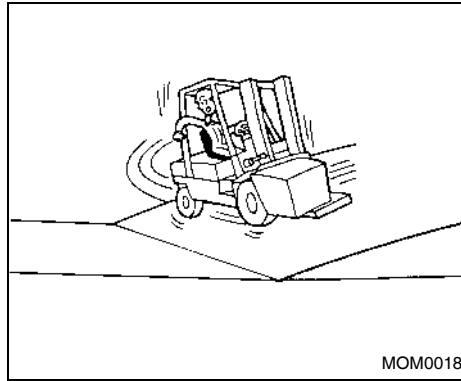

⚠ WARNING:

Do not traverse and turn around on slopes.

- Because driving on slopes causes the center of gravity to shift towards the lowest point, the forklift is likely become unbalanced.

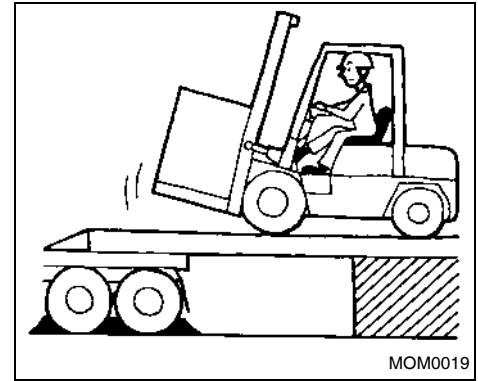

⚠ WARNING:

Following are precautions relating to driving onto freight cars and trailers.

- Check freight cars and trailers to make sure that they will not move.
- The ramp for driving the forklift onto a freight car or trailer shall have sufficient strength to withstand the weight of the forklift and its load, as well as the forces exerted by the bouncing of the forklift.
- The ramp shall be anchored so that it does not shift.
- Use the utmost care when driving on and off a freight car or trailer.

TRANSPORTING FORKLIFT



WARNING:

1. Tilt the mast back to the maximum without load.
2. Check the approach and departure angles to make sure that the underside of the forklift does not come into contact with the load carrying platform or the ground.
3. When using a load bridge, make sure that the planks are capable of withstanding the deadweight of the forklift.
4. When winching the forklift onto a load carrying platform, be sure to attach the cable to the traction pin. Do not ride on the forklift while it is being winched.
5. Be sure to use lashing points and firmly secure the forklift to the load carrying platform.
6. When hoisting the forklift, be sure to use the lifting points.
7. Turn off the ignition switch and remove the key.
8. Make sure that the battery connector is disconnected.

APPROACH ANGLE, DEPARTURE ANGLE AND GANGWAY

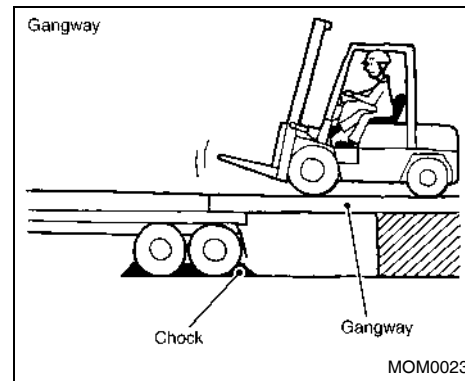
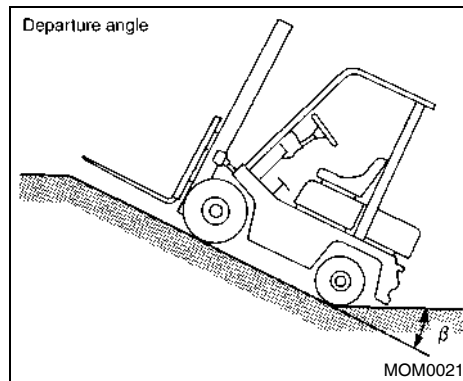
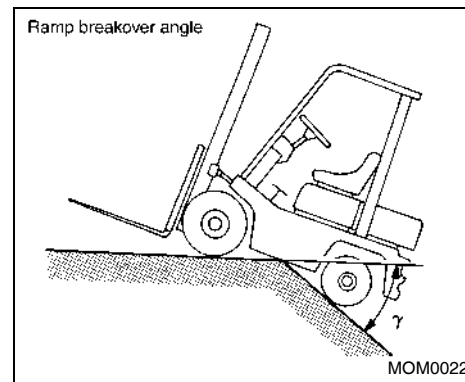
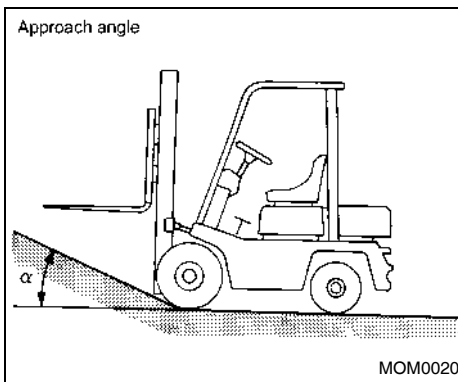

Except for EU region

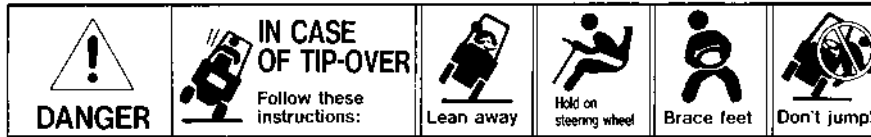
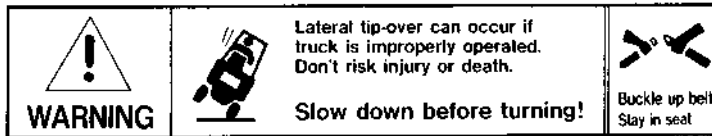

For EU region

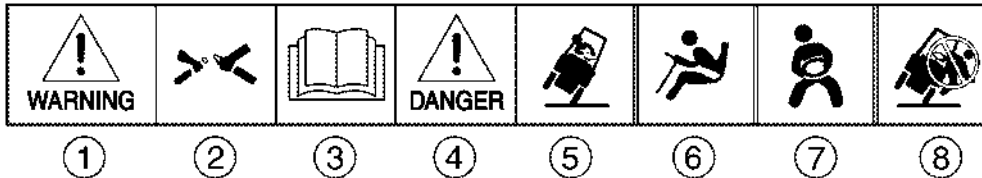

MOM2796

 **WARNING:**

- ① The following precautions should be closely observed to ensure safe operation of the forklift as well as to prevent personal injury.
- ② Always make sure your seatbelt is securely fastened, and stay seated while driving.

- ③ Read the manual carefully before operating the truck to familiarize yourself with the safety instructions.

 **DANGER:**

- ④ The operator should stay inside the forklift if the forklift starts to tip or falls off a dock or ramp.

The operator should:

- ⑤ Lean away from the point of impact.
- ⑥ Hold on firmly to the steering wheel with both hands.
- ⑦ Brace your feet and keep yourself inside the operator compartment.
- ⑧ Do not jump outside of the forklift.

SPECIAL OPERATING CONDITIONS

When operating the forklift under severe climatic conditions such as high temperatures, high altitudes, in cold storages, and when handling explosives and combustibles, and in areas where the forklift is apt to cause radio interference, make sure that the forklift is manufactured and approved as conforming to the local specifications, laws and regulations.

INSTALLATION OF ATTACHMENTS



WARNING:

Before installing hook-on attachments, be sure to read the installation manual issued by the attachment manufacturer to assure correct and proper installation. Contact an authorized UniCarriers FORKLIFT dealer for the revised load capacity figures.

POSITION OF LABELS



WARNING:

When warning and caution labels are damaged such that they cannot be read or have peeled off, they should be immediately replaced with new labels to ensure that they are constantly maintained in a legible condition. The warning and caution labels are available at an authorized UniCarriers FORKLIFT dealer.

- The warning and caution labels are affixed to the designated locations of the forklift as shown in the figure on the following page. Before operating the forklift, be sure to take note of the details given in the labels so as to ensure proper and safe operation.

POSITION OF WARNING AND CAUTION LABELS

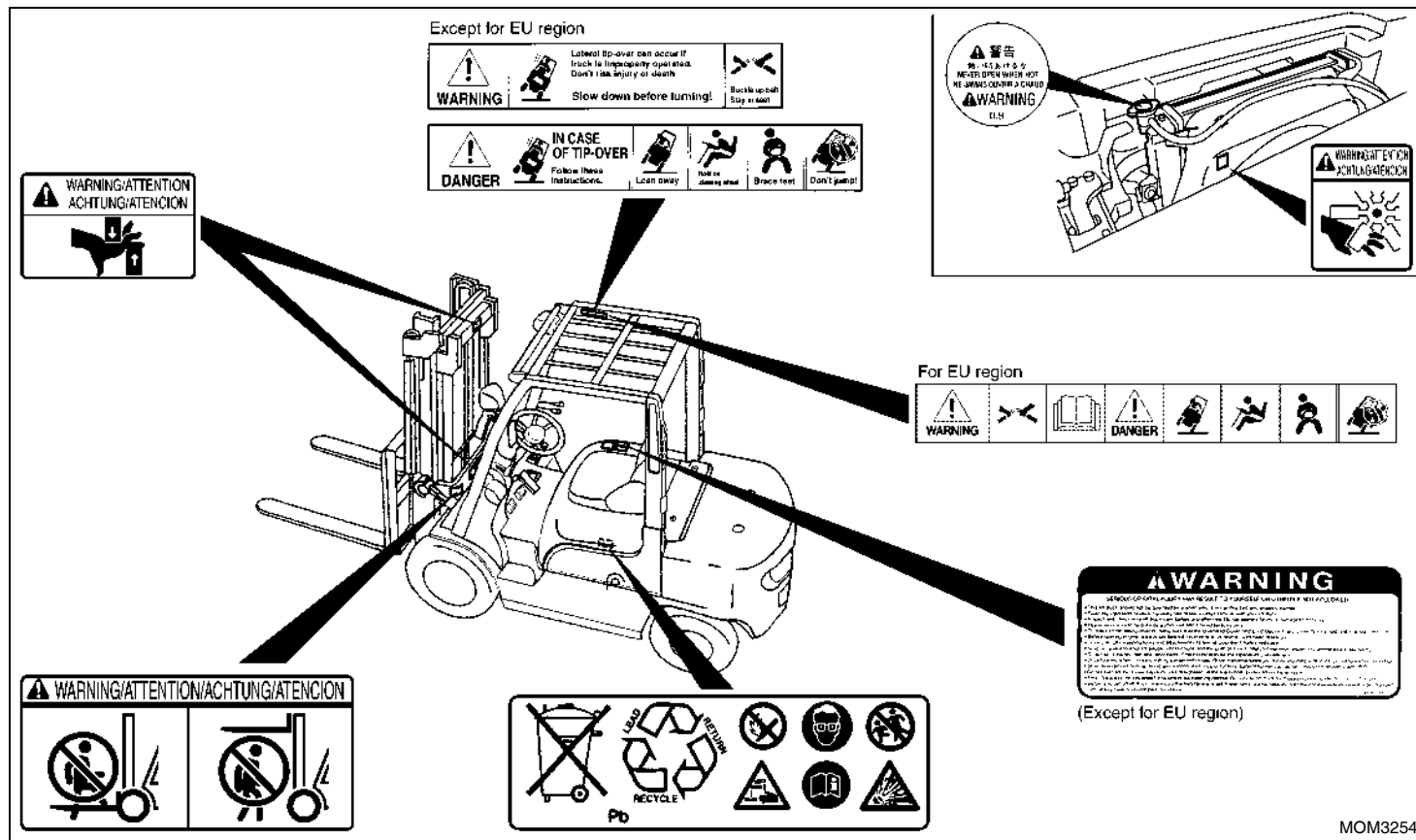

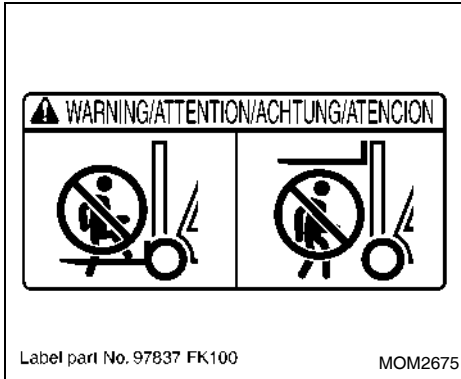

⚠ WARNING:

Do not stand on or below forks.

- **Riding on the forks is strictly prohibited. Furthermore, do not stand immediately below the forks. Otherwise, serious accidents can occur if the forks should move abruptly and the load placed on the forks unexpectedly falls down. In the worst cases, these accidents can be fatal.**



⚠ WARNING:

Be sure to keep your hands, feet and body away from the masts. Otherwise, parts of the body are liable to become caught between the moving and fixed sections of the masts and injury may occur.

Except for EU region

WARNING

SERIOUS OR FATAL INJURY MAY RESULT TO YOURSELF OR OTHERS IF NOT FOLLOWED

- This lift truck should not be operated by anyone who is not authorized and properly trained.
- Read the Operators Manual carefully, and make yourself familiar with your lift truck.
- Inspect and check your lift truck daily before and after use. Do not operate faulty or damaged lift trucks.
- Repair work should be done by authorized and trained persons only.
- To protect from falling objects, make sure that the Overhead Guard and Load Backrest are correctly mounted and in good condition
- Before starting engine, always set forward/reverse lever in neutral, with hand brake on.
- Drive carefully, keeping forks and attachments as low as possible & fully tilted back.
- Keep a careful lookout for people, obstructions and the path of travel. Watch clearance, especially overhead and tail swing.
- Do not stick hands, feet and other parts of your body outside the Operators compartment.
- Drive forward when you are climbing a slope with a load. Drive in reverse when you are descending with loads. Do not turn while on a slope.
- Slow down before turning. Avoid any sudden start, stop or turning. Lateral tipover can occur if truck is improperly operated.
- Do not load lift truck over capacity limit designated on the load chart. Do not lift unstable loads.
- This lift truck is not designed for raising or transporting people. Do not use lift truck for those purposes under any circumstances.
- Before you get off lift truck, make sure the hand brake is set, lower forks or attachments, put forward/reverse lever in neutral position and turn off key switch. Do not park on a slope.

930A0 26H11

MOM2807



WARNING:

Operation precautions

- This label contains instructions on how to operate the forklift safely and avoid accidents. Therefore, be sure to take careful note of the instructions before operating the forklift.

Except for EU region

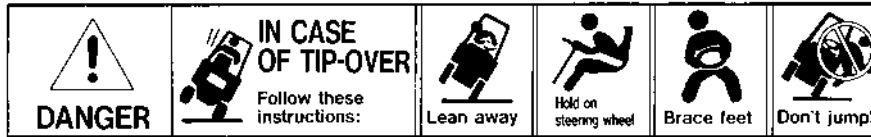
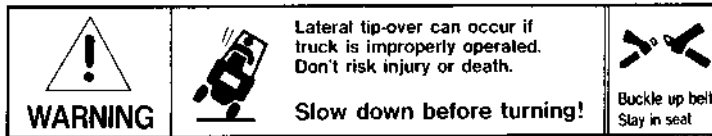

For EU region

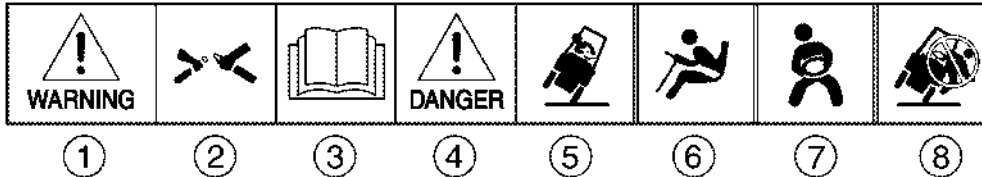

MOM2796

 **WARNING:**

- ① The following precautions should be closely observed to ensure safe operation of the forklift as well as to prevent personal injury.
- ② Always make sure your seatbelt is securely fastened, and stay seated while driving.

- ③ Read the manual carefully before operating the truck to familiarize yourself with the safety instructions.

 **DANGER:**

- ④ The operator should stay inside the forklift if the forklift starts to tip or falls off a dock or ramp.

The operator should:

- ⑤ Lean away from the point of impact.
- ⑥ Hold on firmly to the steering wheel with both hands.
- ⑦ Brace your feet and keep yourself inside the operator compartment.
- ⑧ Do not jump outside of the forklift.



WARNING:
Never open the radiator cap while it is hot.
 Touching the radiator cap while it is hot may result in injury to your hand.

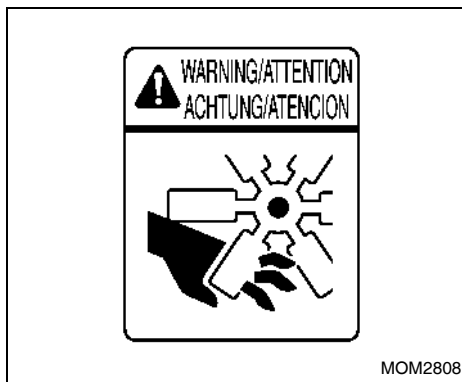

WARNING:
Never touch the cooling fan while it is turning.
 Touching the cooling fan while it is turning may result in injury to your fingers, and in the worst case, may sever the fingers.

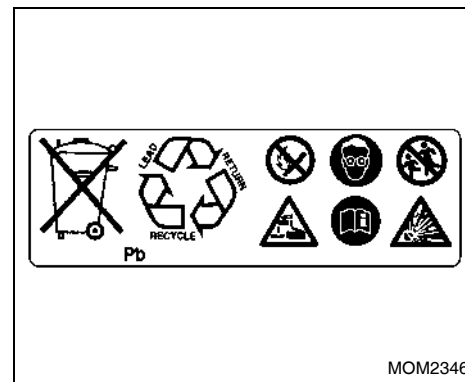

WARNING:

- Diluted sulfuric acid and lead are used in the battery.
- Used battery fluid and batteries shall be disposed of according to the applicable provisions of the local laws and regulations.
- Consult with an authorized UniCarriers FORKLIFT dealer about the disposal of the used battery fluid and batteries.

INSTRUMENTS AND CONTROLS

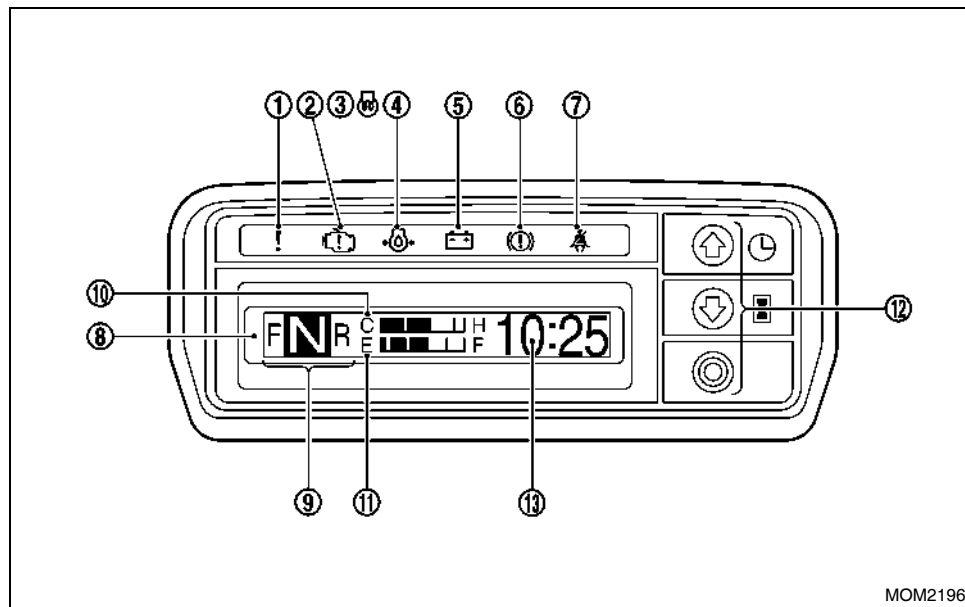

- ① Multipurpose warning lamp
- ② Engine check lamp
(gasoline/LPG engine forklifts only)
- ③ Glow pilot lamp
(diesel engine forklifts only)
- ④ Oil pressure warning lamp
- ⑤ Charge warning lamp
- ⑥ Parking brake warning lamp
- ⑦ Seat belt warning lamp
- ⑧ Liquid Crystal Display (LCD)
- ⑨ Selector lever position (left side of LCD)
- ⑩ Water temp. gauge (top center of LCD)
- ⑪ Fuel gauge (bottom center of LCD)
- ⑫ Operation buttons
- ⑬ Time (right side of LCD)

NOTE:

- In place of the time, the date or hour meter may be displayed.
- While driving, this display changes to the speedometer when the vehicle speed is 4.0 km/h (2.5 MPH) or higher.
- This display also indicates the inspection/service timing, malfunctions and warnings.



CAUTION:

The display time and date will be reset if the battery cable is disconnected or the battery is replaced. If the display has been reset, set the time and date again.

CHANGING METER DISPLAY

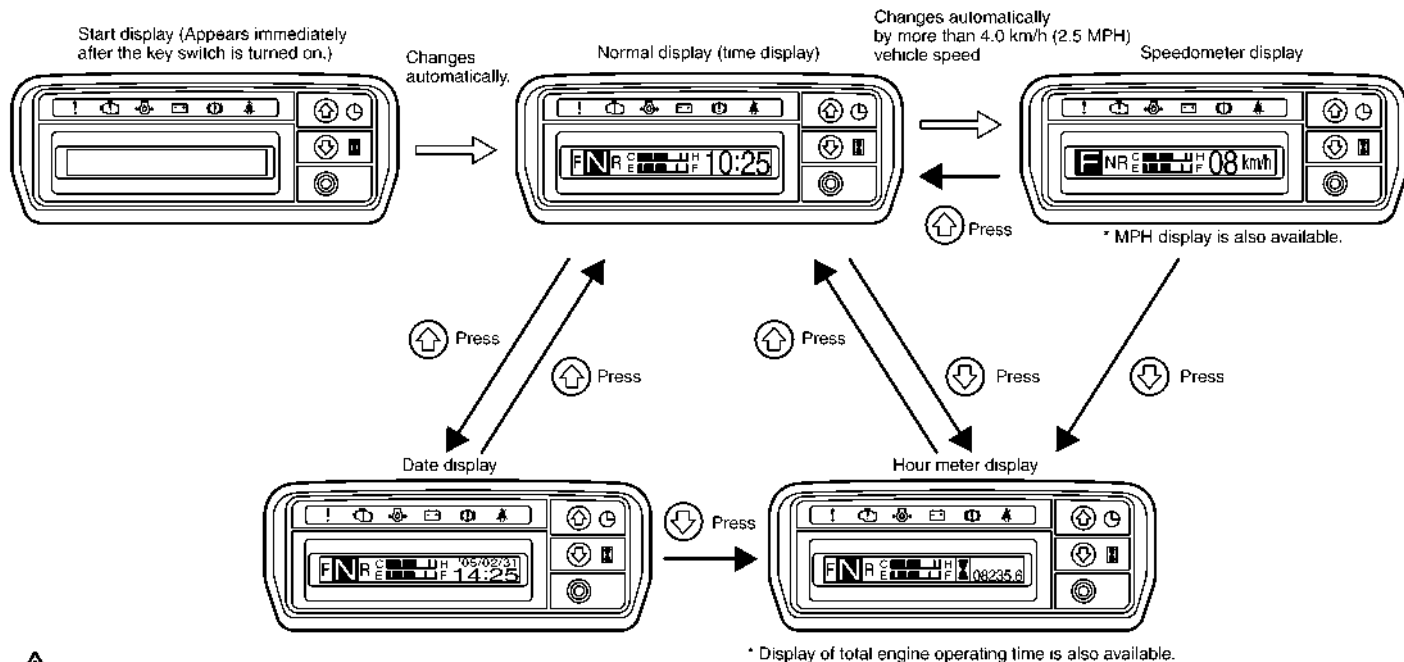

CAUTION

The display time and date will be reset if the battery cable is disconnected or the battery is replaced. If the display has been reset, set the time and date again.

NOTE: For the changes marked with an (*), contact the nearest UniCarriers FORKLIFT dealer.

METER ILLUMINATION

An illumination lamp is provided for meters to ensure visibility at night.

OPERATION BUTTONS

Use these buttons to change the display, make settings (time and date) and enter the password.

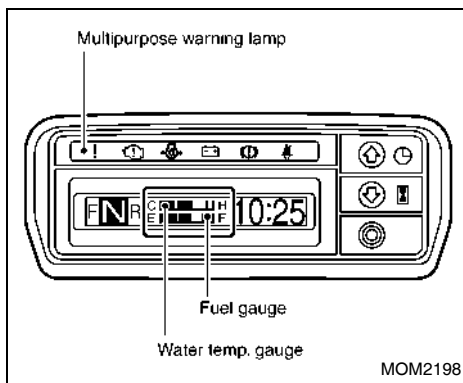

WATER TEMP. GAUGE

Indicates the current water temperature in levels 0 - 4. When level 2 is indicated, the coolant temperature is correct. When the indication reaches level 4, the display begins to blink, and the multipurpose warning lamp illuminates to inform the operator of the high water temperature.



CAUTION:

If level 4 is indicated, stop the forklift and allow the engine to cool while idling. After the engine has sufficiently cooled down, turn the engine off, and check the coolant level and fan belt deflection.

Temp.	Indication	Level
High	C ■■■■ H + !	Level 4
↑	C ■■■■ H	Level 3
	C ■■■■ H	Level 2
	C ■■■■ H	Level 1
	C ■■■■ H	Level 0
Low	C ■■■■ H	Level 0

The diagram is labeled 'MOM2199' in the bottom right corner.

Note to the operator:

All ECCS forklifts in North America have a creep home feature that will reduce engine RPMs if the coolant temperature remains near the “H” position. This indicates that the unit should be serviced by an authorized UniCarriers FORKLIFT dealer.

- To check the remaining amount of LPG, use the fuel gauge on the LPG cylinder.

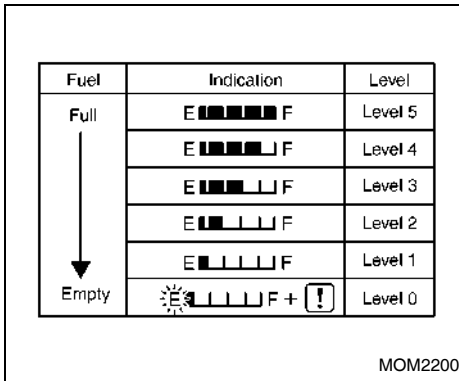

FUEL GAUGE

Indicates the current fuel level in levels 0 - 5. When level 5 is indicated, the fuel tank is full. When the indication reaches level 0, the display begins to blink, and the multipurpose warning lamp illuminates to inform the operator of the nearly empty fuel tank. The fuel tank is nearly empty. Add fuel immediately.

NOTE:

- If the forklift is an LPG - gasoline dual fuel vehicle, the fuel meter will not work when the forklift is operated with LPG.
- When operating the forklift with LPG, check from time to time to be sure that the LPG level warning lamp is not lit and that the LPG level alarm is not on.

SELECTOR LEVER POSITION

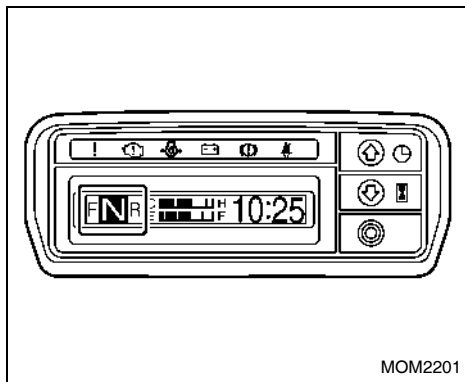

When the selector lever is in the “F” position, the display appears as shown here.



When the selector lever is in the “N” position, the display appears as shown here.



When the selector lever is in the “R” position, the display appears as shown here.



- When the selector lever is in the “F” or “R” position and the operator is not seated on the operator’s seat, the display blinks. Sit on the operator’s seat and shift the selector lever to Neutral (N), then shift it again to Forward (F) or Reverse (R) in order to drive.
- When there is an error in the selector lever signal, the display blinks. Contact an authorized UniCarriers FORK-LIFT dealer and request an inspection.

MTM



[N] illuminates only when the selector lever is in the “N” position.

- When there is an error in the selector lever signal, the display blinks. Contact an authorized UniCarriers FORK-LIFT dealer and request an inspection.

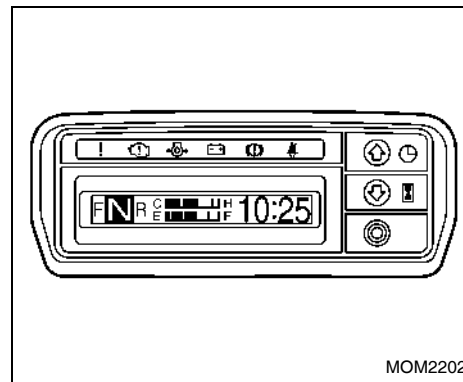

CLOCK



CAUTION:
The time and date will be reset if the battery cable is disconnected (for example, when the battery is replaced). Set the time and date again.

When the ignition switch is turned on, the start display appears, followed by the normal display (clock display).



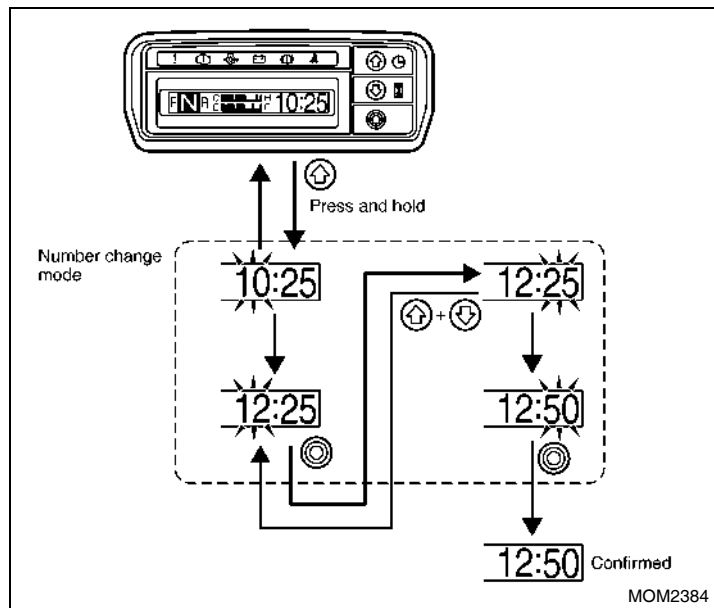

NOTE:

Press the buttons to change the display to the date or hour meter.

SETTING THE TIME



NOTE:

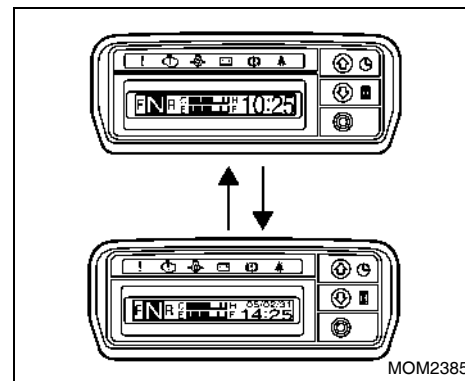

- Press the  button to change from hours → minutes → confirmed.
- Press the  button to change the number down.
- Press both the  and  buttons at the same time to return to the previous display.
- Press the  button to change the number up.



DATE

CAUTION:

The time and date will be reset if the battery cable is disconnected (for example, when the battery is replaced). Set the time and date again.

Press the  button on the normal display (clock display) to change from the time display to the date display. Press  again to return to the normal display.

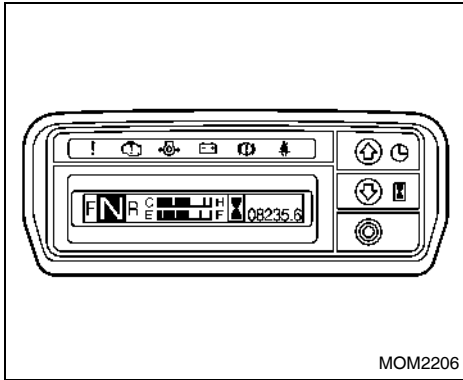

HOUR METER

The buttons can be used to change from the normal display (clock display) to the hour meter display.

The hour meter ordinarily displays the total ignition time that the ignition is on, however it is possible to change the display to the total engine operating time.

To change the hour meter totaling pattern, contact an authorized UniCarriers FORKLIFT dealer.

EXPLANATION OF WARNING LAMPS

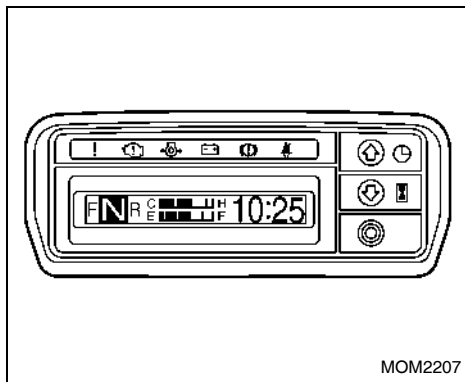

Following is an explanation of the meaning and method of correction when a warning lamp illuminates.

! Multipurpose warning lamp

This warning illuminates when one of the LCD warning symbols illuminates. It also illuminates when the water temperature is high or the fuel level is low. If this lamp illuminates during operation, stop operation immediately, report to the person having management duties and take necessary measures.



Malfunction indicator lamp
(gasoline/LPG engine forklifts only)

This warning illuminates when there is malfunction with an engine sensor or air-fuel ratio control.



Glow plug indicator lamp
(diesel engine forklifts only)

This warning illuminates when the ignition switch is turned on, and it turns off when glow plug preheating is completed.



CAUTION:

- If the lamp remains illuminated after the glow plugs are preheated, this indicates a malfunction in the glow system.
- Have the system checked at your nearest authorized UniCarriers FORKLIFT dealer.



Oil pressure warning lamp

This warning illuminates when the oil pressure is low.



CAUTION:

If the lamp illuminates under ordinary operating conditions, stop the engine immediately and check the engine lubrication system.



Charge warning lamp

This warning illuminates when there is a malfunction with the charge system.



CAUTION:

If the lamp illuminates or flickers occasionally during normal operating conditions, the alternator and electrical system should be checked.



Parking brake warning lamp

This warning illuminates when the parking brake lever has been pulled.



Seat belt warning lamp

This warning illuminates when the seat belt is not fastened.

LCD WARNING SYMBOLS

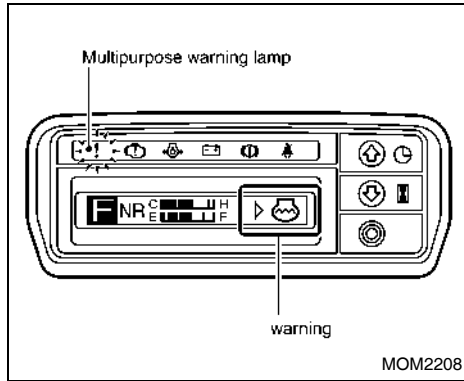

When a forklift warning occurs, a warning symbol and the multipurpose warning lamp illuminate. Following is an explanation of the meaning and method of correction when a warning symbol illuminates.

Mast interlock warning

This warning illuminates when the ignition switch is turned on and the operator is not seated on the seat. Loading operation is prohibited at this time. Loading becomes possible when the operator is seated on the seat.

LPG level warning/LPG rack lock warning (LPG and DUAL forklifts only)

This warning illuminates when the LPG level is low. Replace the LPG fuel cylinder before the fuel (LPG) runs out.

 **CAUTION:**
The LPG tank is out of or nearly out of fuel. Have LPG cylinder tank replaced immediately.

Torque converter fluid temp. warning

This warning illuminates when the transmission fluid temperature is high. If this warning symbol illuminates, move the vehicle to a safe location and allow it to idle in order to lower the fluid temperature. When the fluid temperature has returned to normal, the warning turns off.

NOTE:

- **Check the level of automatic transmission fluid. (For more information, refer to “Automatic transmission fluid level” on page 87.)**
- **If the warning lamp illuminates even though the transmission fluid is at a normal level, ask your nearest authorized UniCarriers FORKLIFT dealer to perform an inspection.**

Radiator level warning

This warning illuminates when the engine coolant level is low. Add coolant.

 **CAUTION:**
Continuing to drive while the lamp is illuminated may lead to overheating of the engine.

Air cleaner warning

This warning illuminates when the air cleaner has become clogged. If this warning symbol illuminates, promptly clean or replace the air cleaner.

Fuel filter warning (for diesel engine forklifts)

This warning illuminates when the fuel filter has become full with water. If this warning symbol illuminates, promptly drain the water from the fuel filter.

 **CAUTION:**
Continuing to drive while the lamp is illuminated may lead to a reduction in the engine output or engine damage.

INSPECTION TIMING DISPLAY

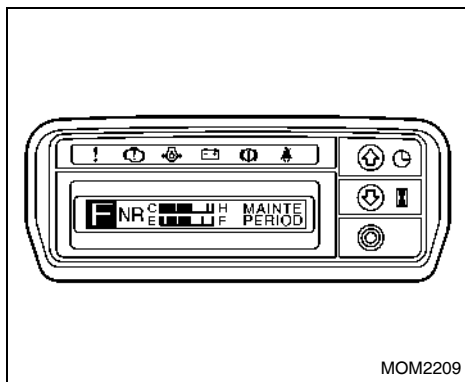

When the time for regular inspection approaches, this warning illuminates for 15 seconds after the ignition switch is turned on. This does not affect driving.

When the display shown above appears, contact an authorized UniCarriers FORKLIFT dealer. It is recommended that regular inspection be performed.

DISPLAYS WHEN MALFUNCTION OCCURS

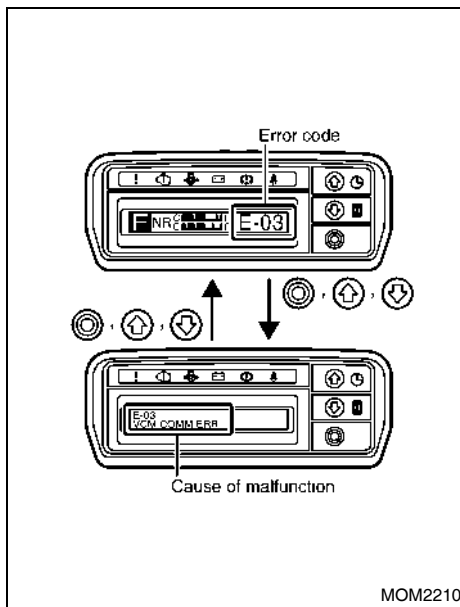

When controller malfunction occurs, an error code is displayed.

Press a button while the error code is displayed in order to display the cause of the malfunction.

If the display above appears, contact an authorized UniCarriers FORKLIFT dealer.

DRIVER RECOGNITION MODE

Registering a password can restrict the drivers of the forklift.

You can register a password for up to 5 persons (A to E).

Contact an authorized UniCarriers FORKLIFT dealer for information about the registration of the password.

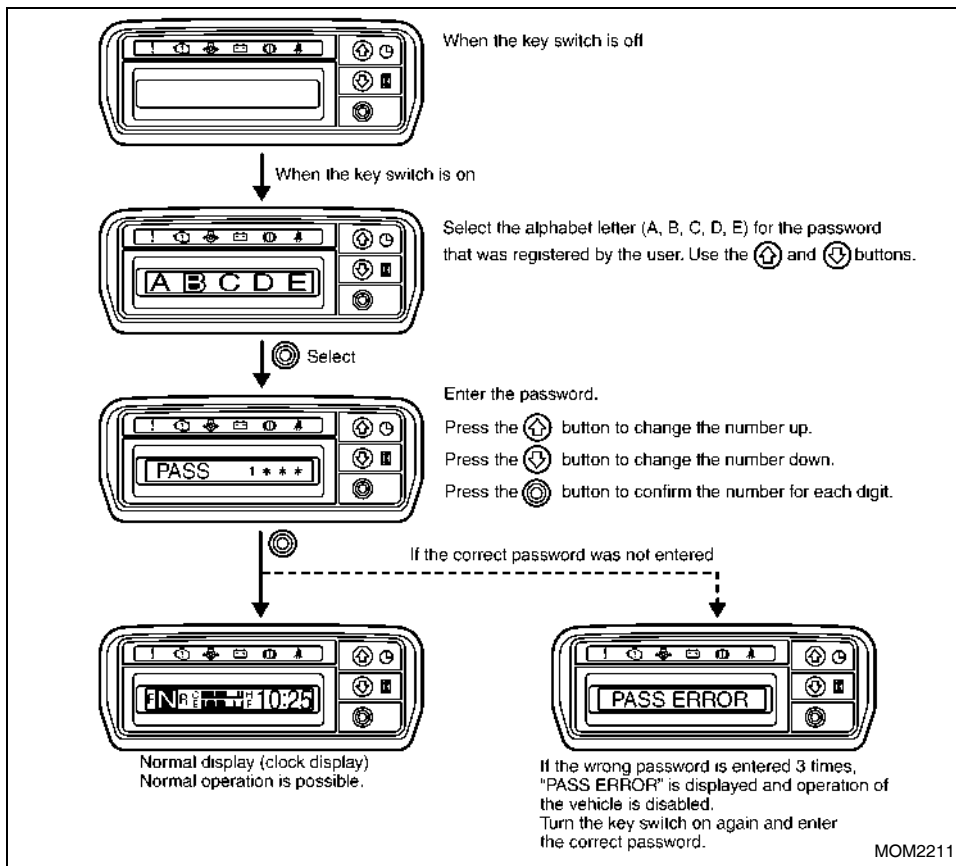

MANAGER MODE

Manager mode can be used by the manager to check and reset the operating time for each operator, and to change passwords.

- The manager must not disclose to the operators the password required to enter manager mode.

If the manager has forgotten the password, contact an authorized UniCarriers FORKLIFT dealer.

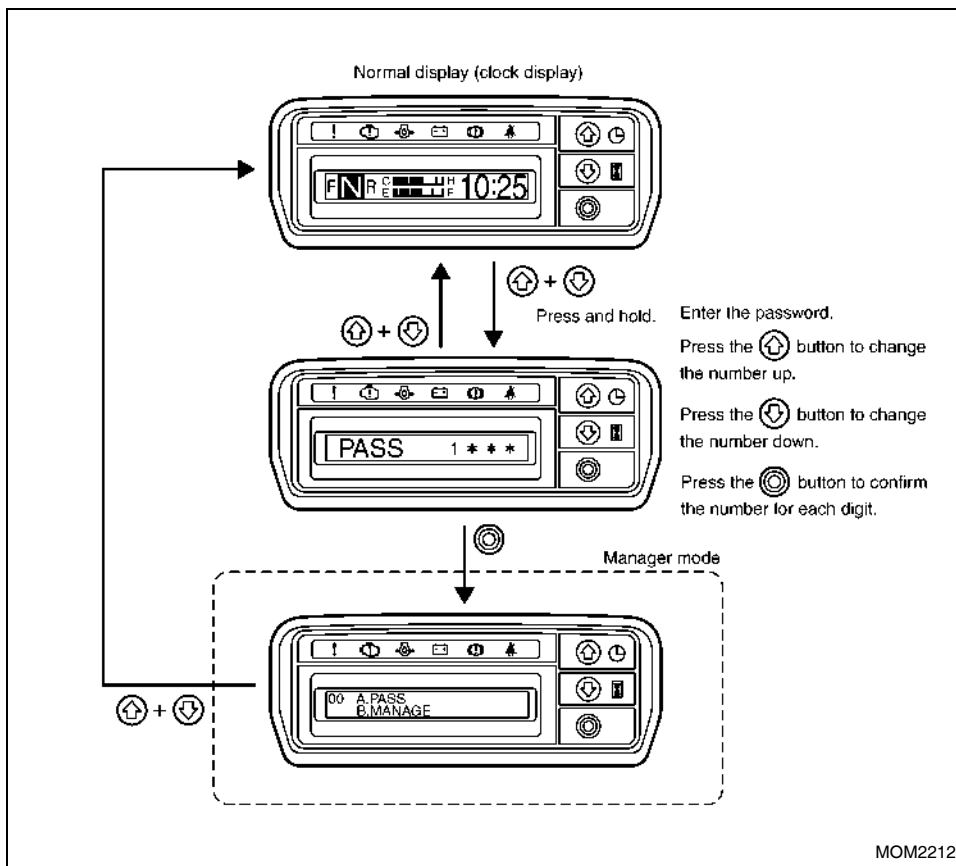

The items that can be changed and viewed in manager mode are the following.

Indication	Explanation
PASS ENTRY	Enable/disable the operator password entry function.
ENTRY TIME	After an operator has entered the password, then it will not be necessary for the same operator to enter the password again for the amount of time set here.
PASS A	Change password "A" for the operator password entry function.
PASS B	Change password "B" for the operator password entry function.
PASS C	Change password "C" for the operator password entry function.
PASS D	Change password "D" for the operator password entry function.
PASS E	Change password "E" for the operator password entry function.
PASS MANAGER	Change the manager mode password.
A***** C*****	Display each of the vehicle operating times when passwords "A" - "D" are used for the operator password entry function.
B***** D*****	
E*****	Display the vehicle operating time when password "E" is used for the operator password entry function.
MANAGE RESET	Reset the vehicle operating times when passwords "A" - "E" are used for the operator password entry function.



CAUTION:

For the methods used to view and change the above items, contact an authorized UniCarriers FORKLIFT dealer.

LPG REMAINING TIME MANAGEMENT

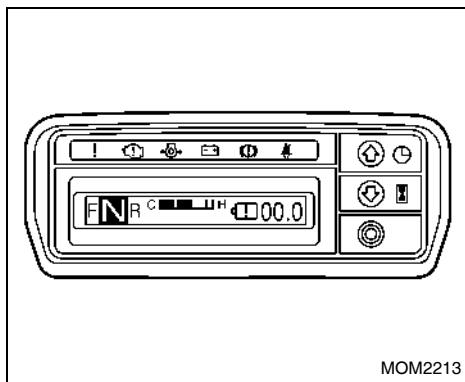

With this function, the operator sets the time interval between LPG fuel cylinder replacements. Then, when this time reaches zero, this function illuminates the LPG level warning symbol and multipurpose warning lamp to warn the operator of the need to replace the LPG fuel cylinder. For the method used to change the LPG level warning pattern to the method above, contact an authorized UniCarriers FORKLIFT dealer.





LPG remaining time management is recommended for the following types of situations.

- The timing for replacement of the LPG fuel cylinder is predetermined.
- The LPG level warning appears too early (or too late) on the forklift that is currently being used.

CAUTION:

- Set a time with a sufficient amount of leeway.
- After replacing the LPG fuel cylinder, be sure to set the time setting again. Otherwise, the time setting continues after LPG fuel cylinder replacement, and this may result in the LPG level warning symbol turning on at an unintended time.
- When driving a dual fuel forklift using gasoline after using LPG without the time setting, be careful that the time setting continues to count the time.

LPG remaining time setting

- When the time setting is set to [ET.00.0], the meter panel shows the LPG level warning .
- When the time setting is reset, move to the setting display by pushing (), () and () while the LPG level warning () is displayed. After resetting the setting time, the LPG level warning turns off.

Following is an explanation of how to set the time setting for the first time.
 Example: Setting the time to 12.3 hours

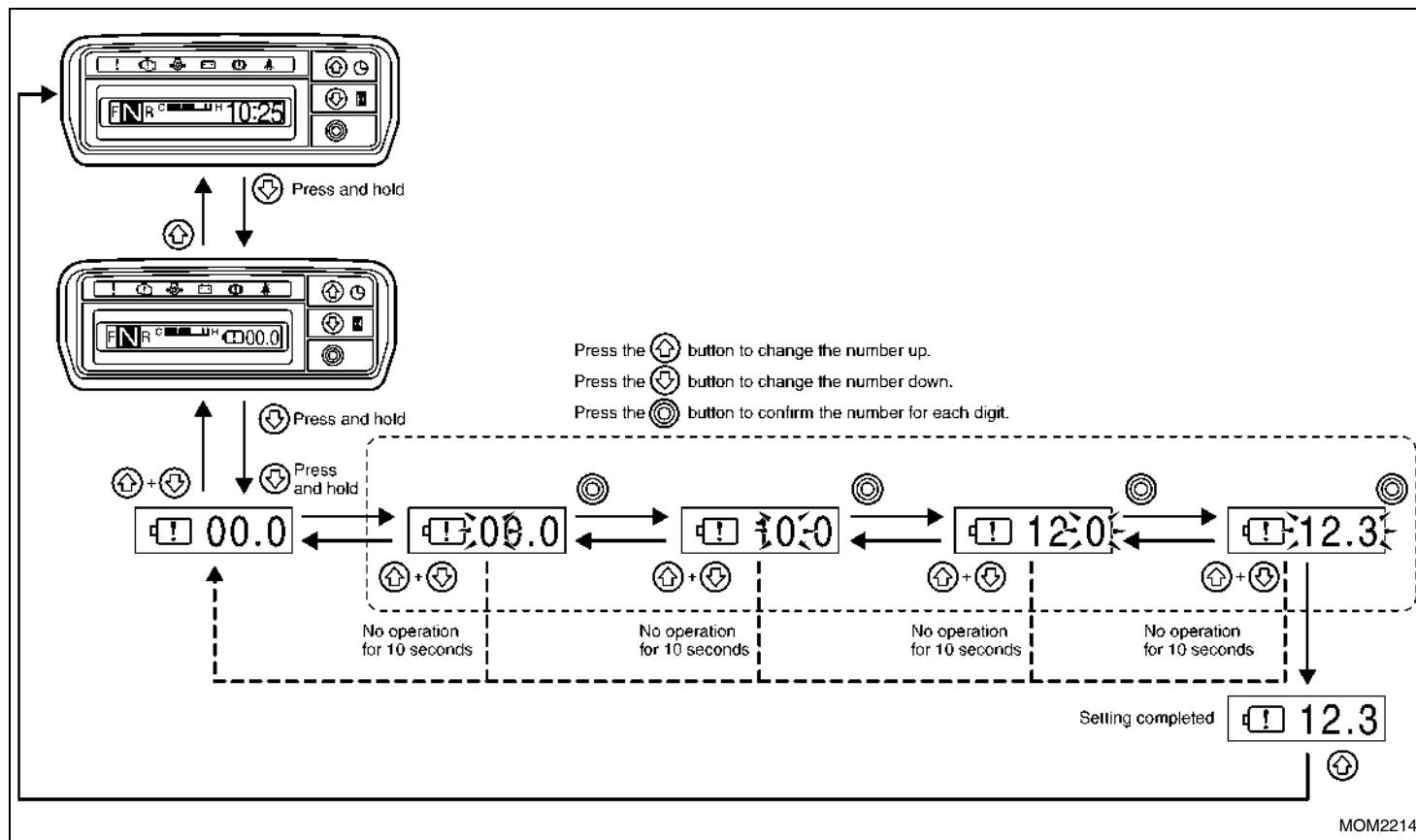

Following is an explanation of how to set the time setting for the second and later times.

Example 1: Changing the time from 12.3 hours (previous setting) to 6.5 hours

Example 2: Using the same 12.3 hours setting (previous setting) again

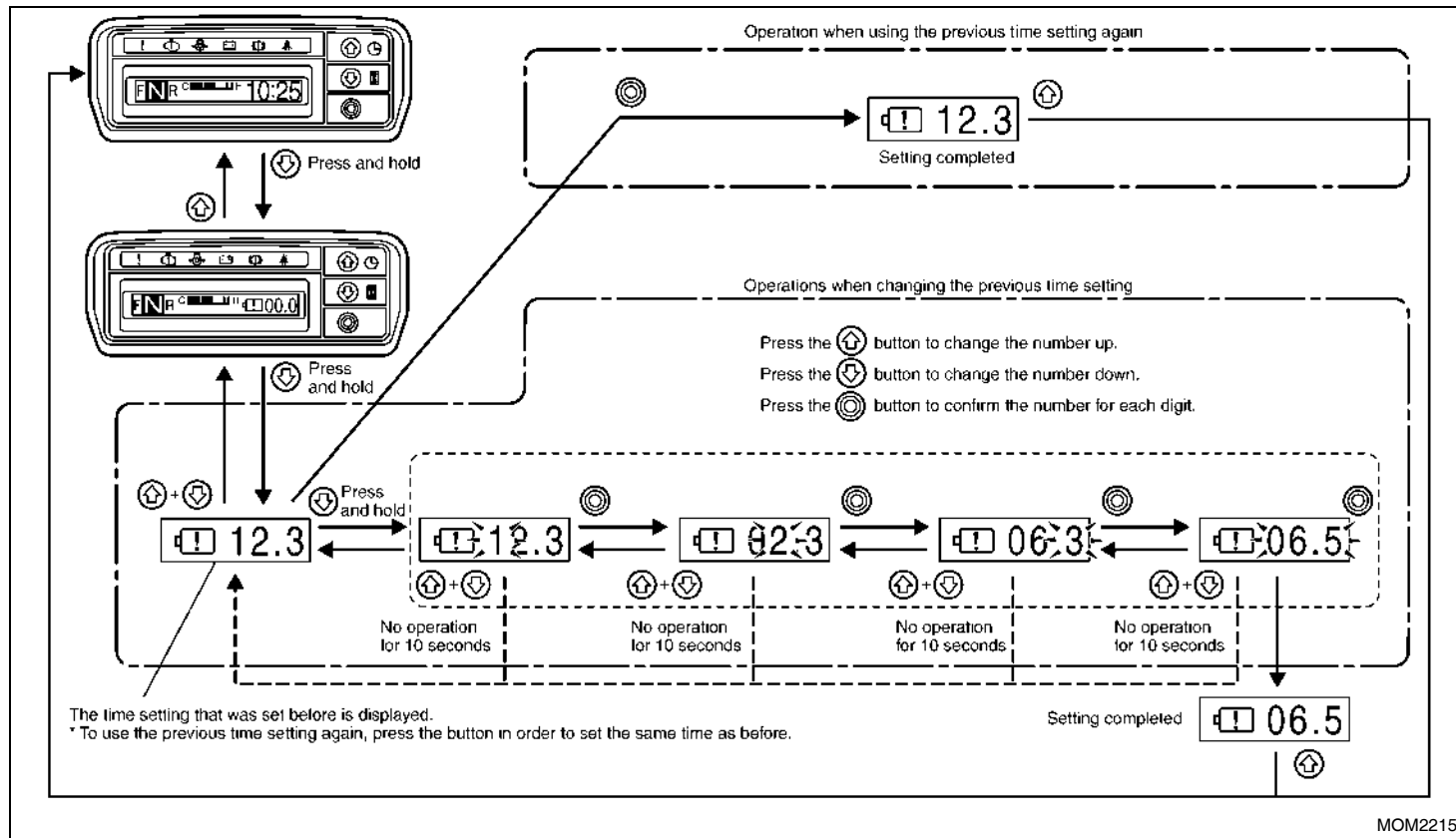

SWITCHES AND CONTROLS

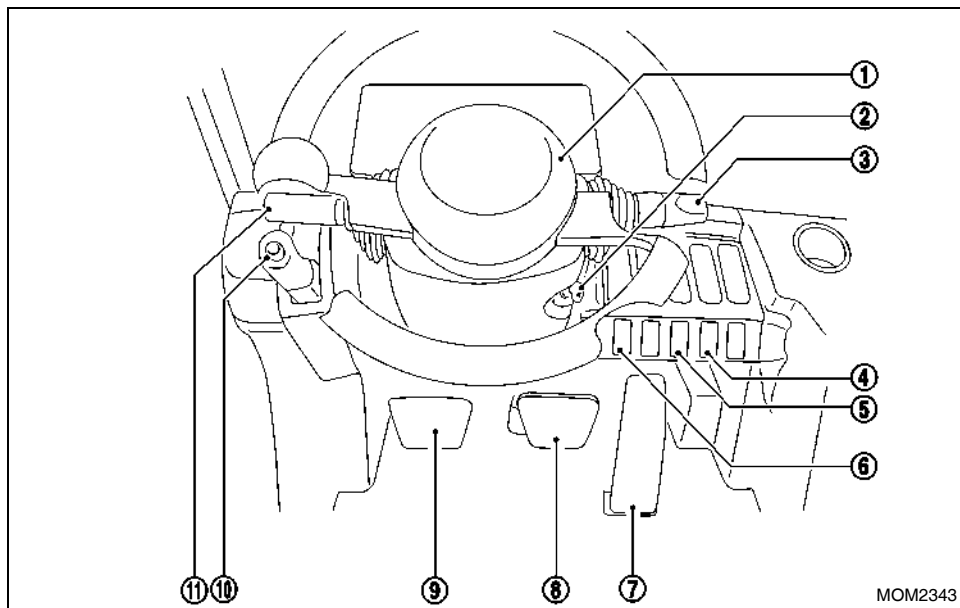

- ① Horn switch
- ② Ignition switch
- ③ Lighting switch and turn signal switch

NOTE:

In forklifts with the optional joystick control, this switch is located on the left side.

- ④ Throttle sensitivity adjust switch (option)
- ⑤ Maximum speed change switch (option)
- ⑥ Fuel-change switch
(LPG - gasoline dual fuel forklift)

- ⑦ Accelerator pedal
- ⑧ Brake pedal
- ⑨ Inching brake pedal
- ⑩ Parking brake lever
- ⑪ Selector lever

NOTE:

- Operation is the same for the optional right-side selector lever.
- For forklifts with the optional joystick control, this switch is located on the joystick control unit.

AUTO STOP/START FUNCTION (option)

This function automatically stops the engine when the forklift has not been operated for the set length of time if the following conditions are also met: the vehicle is idling (the accelerator pedal is not depressed), the selector lever is in the neutral position, the vehicle is stopped and no malfunctions have occurred. When this function stops the engine, "AUTO STOP" is displayed on the LCD panel.

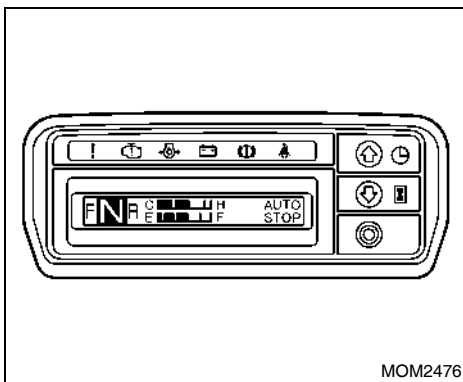

Setting at the time of shipment from factory: 60 seconds

Adjustable range: 0 - 200 seconds

- **A setting of 0 seconds disables the auto stop function.**
- **The status when auto stop is activated is the same as when the ignition switch is turned OFF. (The headlamps can be turned ON, however the turn signal lamps will not operate.)**

To restart the engine from the auto stop status, leave the selector lever in the neutral position and sit in the seat, then depress the inching brake pedal or brake pedal and at the same time depress the accelerator pedal. This will restart the engine.

The engine can also be restarted by turning the ignition switch to the START position.

To change the setting for this function, please contact the nearest UniCarriers FORKLIFT dealer.

NOTE:

The set time before auto stop activates can be adjusted within the range of 0 - 200 seconds.

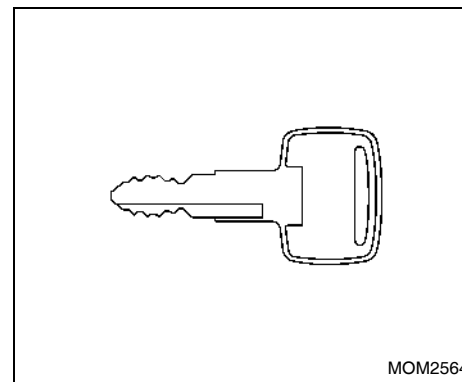

IGNITION KEY

Insert the ignition key in the ignition switch to start or stop the engine.

NOTE:

- **Two ignition keys are provided with every UniCarriers FORKLIFT. Use one key for operation and store the other in a safe place as a spare.**
- **Be sure to take a note of the key number in case the key is lost. You need to specify the key number when placing an order for additional spare keys to an authorized UniCarriers FORKLIFT dealer.**

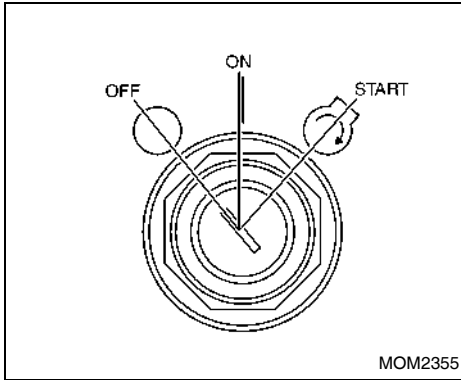

IGNITION SWITCH

OFF position

The position that allows the ignition key to be inserted into or removed from the ignition switch. When the ignition switch is in this position, all electric circuits are open but the following can be turned on and off.

- Horn
- Lamps by operating the lighting switch
- Rear operating lights (option)
- Braking lamps by the application of the brake

ON position

The position in which the ignition switch is placed when the engine is running. When the ignition switch is in this position, all electric circuits are closed.

START position

To start the engine, turn the ignition switch to the ON position, then to START. When you take your hand off the ignition key after starting the engine, the key returns to this ON position automatically.

NOTE:

- **If you leave the ignition switch in the ON position while the engine is stopped, the battery may run down, and this may make it impossible to start the engine. To avoid this situation, always return the ignition switch to the OFF position after stopping the engine.**
- **During operation, the ignition switch is in the ON position. Never turn it to the OFF or START position.**
- **Do not operate the starter for a long time when starting the engine.**
- **If the engine does not start even though you operate the starter repeatedly, return the ignition switch to the OFF position, wait for a short period of time until the battery is restored to a normal voltage level, and then try to start the engine again.**

Gasoline engine forklift

Do not operate the starter for more than 10 consecutive seconds. If the engine does not start, wait for at least 10 seconds and then try to start it again.

Diesel engine forklift

Do not operate the starter for more than 30 consecutive seconds. If the engine does not start, wait for at least 30 seconds and then try to start it again, starting with preheating.

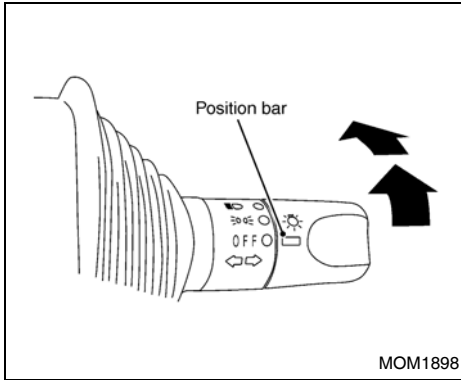

LIGHTING SWITCH

To turn on one of the lamps listed in the table, turn this switch to align the position bar (–) on the switch knob with the corresponding mark on the switch main unit.

Switch mark	Headlamp	Tail lamp
OFF	Off	Off
	Off	On
	On	On



CAUTION:

Do not touch the headlamp lens when the headlamp is lit or immediately after the headlamp is turned off, because it is very hot.

NOTE:

- You can turn lamps on and off by turning the lighting switch, regardless of the position of the ignition switch.
- Do not forget to turn off all lamps when leaving the forklift, otherwise the battery may run down.

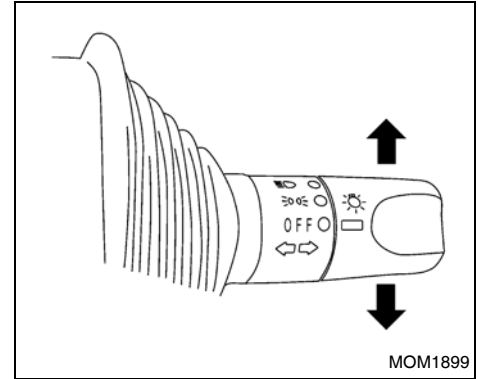

TURN SIGNAL SWITCH

Push the switch lever forward when turning left, and pull it backward when turning right. The appropriate turn signal will blink. Upon completion of the turn, be sure to return the lever to its original position.

HORN SWITCH

Pushing the switch in the center of the steering wheel will sound the horn, regardless of the key position.

NOTE:

For forklifts with the optional joystick control, a horn switch is also located on the joystick control unit.

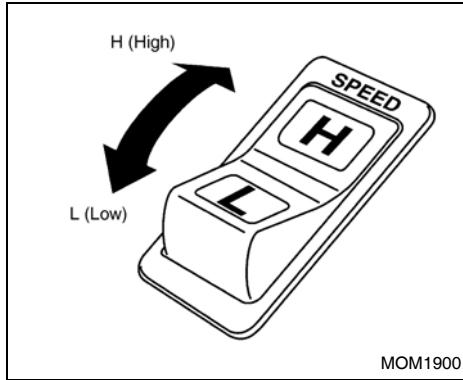

MAXIMUM SPEED CHANGE SWITCH (option)

This switch is an optional setting switch for electronic control gasoline vehicle and gasoline-LPG vehicle or diesel speed control vehicle. It allows you to switch the maximum speed between H (high speed mode) and L (low speed mode). Press the H (high) side of the switch if there is no need to limit the maximum speed to a low level, or press the L (Low) side to limit the maximum speed to a low level.

The lamp on the side you pressed illuminates, indicating the speed mode that is currently selected.

CAUTION:

- Do not change the maximum speed when the forklift is running. Doing so could cause the load to shift.
- Only authorized UniCarriers FORKLIFT dealers are allowed to change the running speed settings. So, if necessary, ask an authorized UniCarriers FORKLIFT dealer to perform this change.

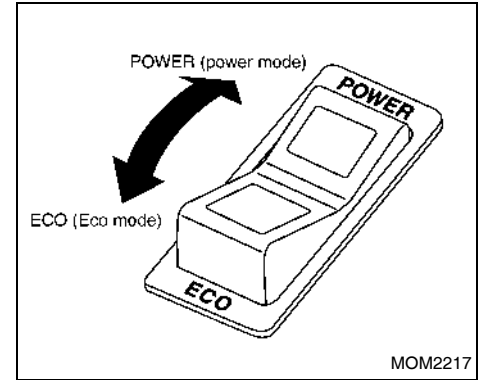

THROTTLE SENSITIVITY ADJUST SWITCH

This switch is an optional setting switch for electronic control gasoline vehicle and gasoline-LPG vehicle. It allows you to switch the starting acceleration between POWER (power mode) and ECO (economy mode). Press the POWER side of the switch to accelerate the forklift at a normal rate, or press the ECO side to accelerate the forklift slowly.

The lamp on the side you depressed illuminates, indicating the power mode that is currently selected. You can switch from one mode to the other, as described in the table.

Switching operation	During driving	During a halt and ignition switch OFF
From POWER to ECO	Not possible	Possible
From ECO to POWER	Not possible	Possible

NOTE:

Switching from the ECO mode to the POWER mode can be done only when the accelerator is released.



CAUTION:

Turn the ignition switch off before changing the POWER/ECONOMY SWITCH.

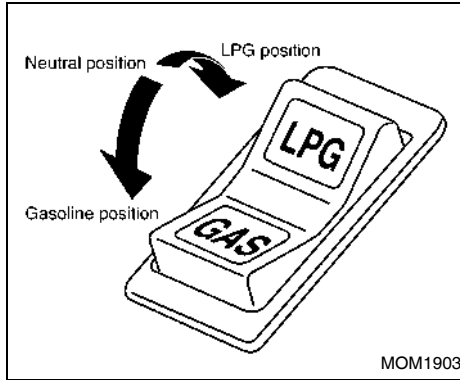

FUEL-CHANGE SWITCH (LPG - gasoline dual fuel forklift)

This switch is used to switch fuel from LPG to gasoline or from gasoline to LPG.

LPG position: Turn to this position to use LPG.

Neutral position: Turn to this position to exhaust fuel from the fuel pipe.

Gasoline position: Turn to this position to use gasoline.

The lamp illuminates for the fuel that is currently being used.



WARNING:

Do not manipulate the LPG cylinder charge valve (green or gray), otherwise LPG may leak out into atmosphere.

NOTE:

- When the engine is running, you can switch between fuels by operating the switch.
- To switch from one fuel to the other, strictly follow the specified procedure after warming up the engine.
- To prevent deterioration of gasoline, drive the forklift with gasoline several kilometers about once every two weeks.
- The engine does not start when the selector switch is in the neutral position. Do not forget to turn the switch to the LPG or gasoline position before starting the engine.

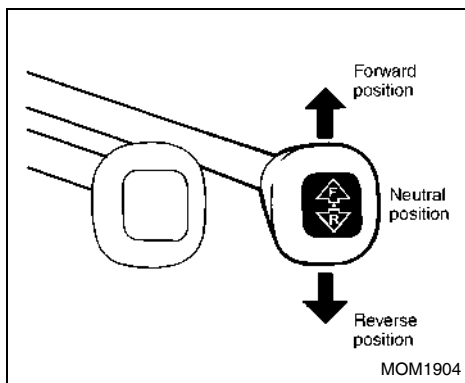

FORWARD-REVERSE LEVER (MT vehicle)

This lever is used to change the running direction of the forklift (forward or reverse). Push the lever forward to drive forward, or pull it towards you to back up. The neutral position is at the midpoint.



CAUTION:

- When starting the engine, always return the forward-reverse lever to the neutral position.
- When operating the lever while the engine is running, be sure to depress the clutch pedal flat.

- Do not operate the forward-reverse lever before the forklift comes to a full stop. When operating the lever, do it correctly while pressing the clutch pedal flat.
- Depending on the model used, the gear shift lever may be placed on the right side of the forward-reverse lever (optional). Before use, therefore, make sure of the position of each lever to avoid operating the wrong lever.

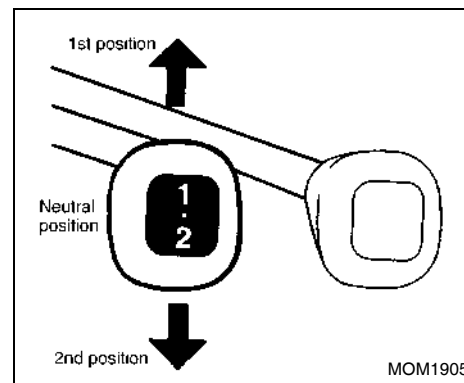

GEAR SHIFT LEVER (MT vehicle)

This lever is used to shift gears between low speed (1st speed) and high speed (2nd speed). Push the lever forward to shift to low gears, or pull the lever towards you to shift to high gears. The neutral position is at the midpoint.

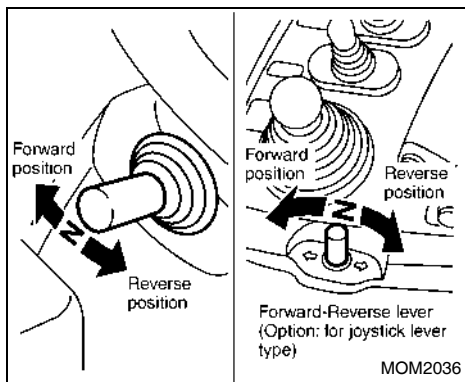

SELECTOR LEVER (AT vehicle)

This lever is used to change the running direction of the forklift (forward or reverse). Push the lever forward to drive forward, or pull the lever towards you to back up. The neutral position is at the midpoint.

The same operating method applies to the selector lever positioned on the right side of the forward-reverse lever (option).

NOTE:

The engine cannot be started when the selector lever is in any position other than the neutral position.

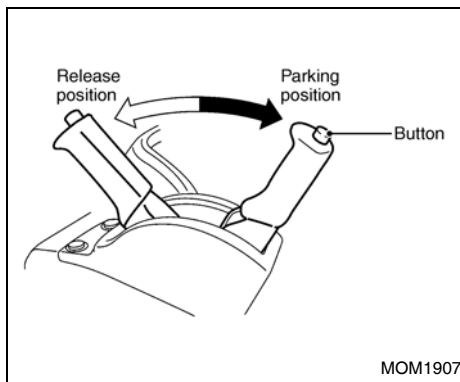

PARKING BRAKE LEVER

When parking the forklift, fully pull the lever towards you. To release the parking brake, push down the button on top of the lever and then push the lever forward.

When parking the forklift on a slope, fully pull the lever towards you and set a chock behind each wheel.

WARNING:

- Always depress the brake or inching pedal before releasing the parking brake to avoid movement of the forklift before selecting a direction.
- Driving the forklift with the parking brake applied could cause the brakes to fail due to overheating. Also, it hastens brake pad wear.

NOTE:

To remind the operator to apply the parking brake, an alarm will sound if:

- The operator leaves the operator's seat without applying the parking brake while the ignition switch is in the ON position.
- The operator turns off the ignition switch without applying the parking brake, whether or not the operator is sitting on the operator's seat.

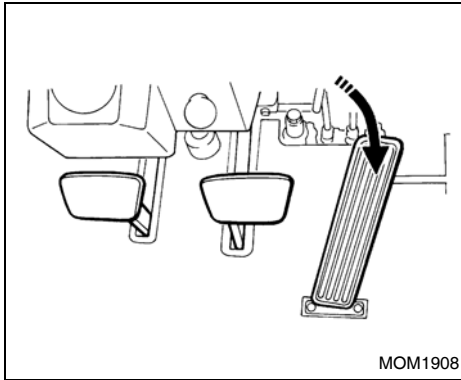

ACCELERATOR PEDAL

This pedal allows you to adjust the rotational speed of the engine. The engine speed changes according to the degree to which the accelerator pedal is depressed.



CAUTION:

Do not depress the accelerator pedal quickly. Depress it slowly to prevent a sudden or rapid start or a shift or falling of cargo.

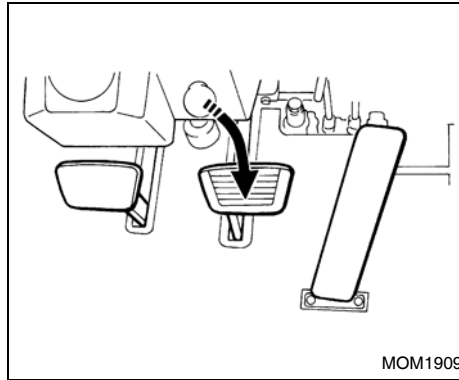

BRAKE PEDAL

This pedal allows you to bring the forklift to a stop or slow it down.



WARNING:

- **Do not brake the forklift too hard. Doing so may cause the forklift to become unbalanced and could result in a serious accident.**
- **Adjust the braking effort according to the cargo weight.**
- **Do not leave your foot on the brake pedal while driving. Doing so may cause the brakes to fail because of overheating. Also, it hastens brake pad wear.**

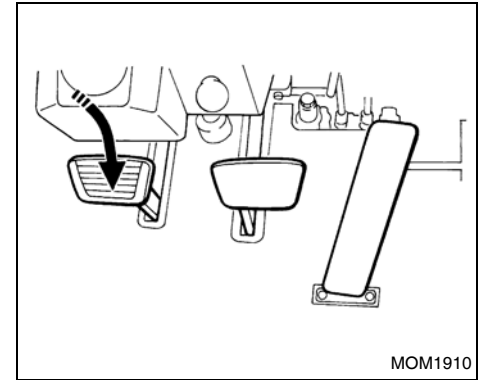

INCHING BRAKE PEDAL (AT vehicle)

The inching brake pedal allows you to finely adjust the forward and reverse running speed.

The clutch begins to slip when you slightly depress this pedal, and the clutch is completely disengaged and the brakes are applied when you further depress the pedal, in which case the inching brake pedal acts in the same way as a brake pedal.



WARNING:

- Do not leave your foot on the inching brake pedal when driving the forklift.
- Doing so may cause the clutch to slip and prevent engine braking from taking effect. Moreover, it could cause the brakes to fail because of overheating.
- Also, doing so may cause the hydraulic clutch in the transmission to slip and give off a large amount of heat, causing the clutch to overheat, wear down in a short time or seize up in the worst case.

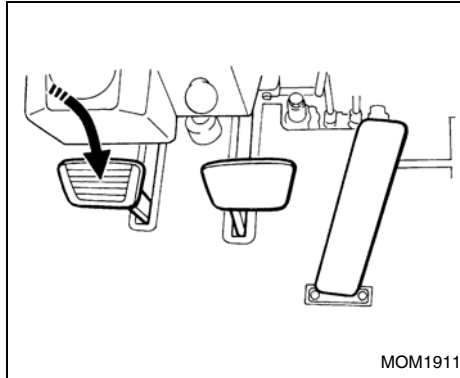

CLUTCH PEDAL (MT vehicle)

This pedal is used along with the forward-reverse lever or the gearshift lever.

When operating the forward-reverse lever or the gearshift lever, depress the clutch pedal flat, shift the forward-reverse lever or the gearshift lever from one position to another, and then slowly take your foot off the clutch pedal.



CAUTION:

- Do not leave your foot on the clutch pedal when driving the forklift.
- Doing so may cause the clutch to slip and hastens the wearing away of the clutch discs.

STARTING AND OPERATING

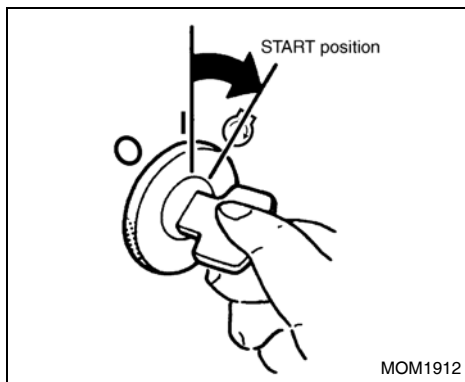

GASOLINE ENGINE STARTING (Including LPG - gasoline dual fuel forklift)

WARNING:

- Do not breathe exhaust gases. They contain colorless and odorless carbon monoxide. Carbon monoxide is a dangerous gas and can cause unconsciousness or death.
- Do not run the engine in closed spaces or poorly ventilated rooms such as a garage or refrigerator, etc.

Follow the procedure outlined below to start the engine.

LPG - gasoline dual fuel forklifts have a fuel-change switch. Use this switch to select the desired fuel.

When using LPG, slowly open the (red) discharge valve on LPG cylinder (tank) to start the engine.

1. Pull the parking brake lever up as far as possible. Move the selector lever to the neutral position.
2. Depress the inching brake pedal as far as it can go.
3. Remove your foot from the accelerator pedal. Turn the starter to start the engine.

NOTE:

Do not operate the starter for more than 10 seconds. If the engine fails to start within 10 seconds, release the starter and wait for 10 seconds before attempting to start the engine again. This allows the battery time to recover.

4. After starting the engine, give it time to warm up. Allow the engine to idle for 1 minute after starting. Then, press the accelerator pedal lightly and release it. If the surrounding temperature is high, lightly pressing and releasing the accelerator pedal will reduce engine speed and permit quiet warming up. This also results in fuel savings.

NOTE:

- The engine is cold immediately after starting. Do not intermittently race the engine or run the engine at high speeds immediately after starting.
- Do not move the key to the START position when the engine is running. Damage to the starter motor will result.
- After operation, always close the LPG (red) discharge valve on LPG cylinder (tank) after shutting the engine off (down).
- After operation, if the forklift is not used for several hours or more, or during cold weather seasons, park the forklift with the fuel-change switch positioned on the gasoline side. This helps to start the engine more easily the next time (LPG - gasoline dual fuel forklift).
- The engine speed becomes high immediately after starting. Exercise caution when moving the forklift or handling cargo.

WARNING:

- Inspect the condition of the LPG hose connections and check for gas leaks from LPG hoses and pipes before starting the engine.
- In the event of LPG leakage or some other malfunction, close the discharge valve immediately. Have the LPG system checked at an authorized UniCarriers FORKLIFT dealer.

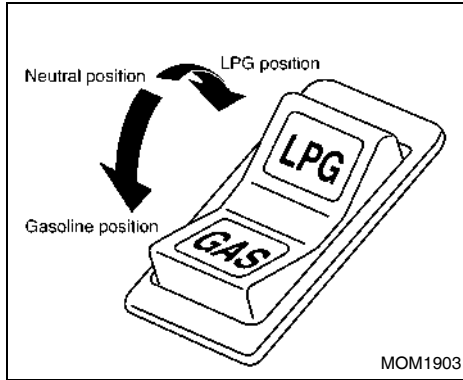

FUEL-CHANGE SWITCH
(LPG - gasoline dual fuel forklift)



WARNING:

Do not operate (turn on or open) the LPG cylinder (tank) change (refill) valve. Opening the valve may cause LPG to leak into the atmosphere and could cause a dangerous fire hazard.

TO CHANGE FROM LPG OPERATION TO GASOLINE OPERATION

1. Press the fuel-change switch and change the switch position from the LPG to the neutral position.
2. Shut off the red or discharge valve on the LPG cylinder side.
3. Let the engine run at idle until it stops.
4. After the engine has completely stopped, move the fuel-change switch to the GAS position. Restart the engine.



CAUTION:

Directly changing over LPG to GAS without the fuel-change switch first being positioned at the neutral position causes the remaining fuel (LPG) and gasoline to be mixed, resulting in a poorly operating engine. Before changing over the switch position, always exhaust the remaining fuel (LPG) by setting the switch to the neutral position.

To change from gasoline operation to LPG operation

1. Press the fuel-change switch and change the switch position from GAS to the neutral position. Slightly depress the accelerator pedal and hold it to allow the engine to race. Continue pressing the accelerator pedal until the engine stops.

2. After the engine has completely stopped, open the red discharge valve on the cylinder side and move the fuel-change switch to the LPG position. Restart the engine.



CAUTION:

Directly changing over GAS to LPG without the fuel-change switch first being positioned at neutral causes the remaining fuel (gasoline) and LPG to be mixed, resulting in a poorly operating engine. Before changing over the switch position, always exhaust the remaining fuel (gasoline) by setting the switch to the neutral position.

NOTE:

- Change over the fuel-change switch position according to the operating procedure of this switch. Otherwise, the air/fuel ratio of fuel (mixture) is negatively affected, making it difficult to start the engine.
- When driving an LPG-gasoline dual fuel vehicle using LPG during the cold weather seasons, first start the engine using gasoline and then change over to LPG with the fuel-change switch after warming up the engine.

- **Do not use the fuel-change switch to change fuels when the engine is running. Change fuels only after the engine has completely stopped.**
- **Operate the vehicle with gasoline for several kilometers at least once every two weeks. This will prevent gasoline deterioration.**
- **Do not change fuels immediately after starting the engine. Allow the engine to warm up before changing fuels.**
- **With the fuel-change switch set to the neutral position, the engine cannot be started. Before starting the engine, always change over the switch position to LPG or gas.**

Carefully follow the procedures below when turning the engine off after LPG operation.

1. Move the fuel-change switch to the neutral position.
2. Let the engine idle until it stops.
3. Make sure that all of the remaining LPG (in the piping and other receptacles) has been used. After the engine stops, turn the ignition switch to the OFF position.
4. After completion of operation and before storing the vehicle for an extended period, completely close the (red) discharge valve.

Check the engine for gas leakage. Refer to “LPG cylinder replacement” on page 112.



WARNING:

- **In the event of gas leakage, an accident, or some other malfunctions, immediately and completely close the discharge valve (colored red). Have the LPG system checked at an authorized UniCarriers FORKLIFT dealer.**
- **If the forklift is not used for several hours or more after operation, park the forklift with the fuel-change switch in the GAS position. This helps to start the engine more easily the next time.**

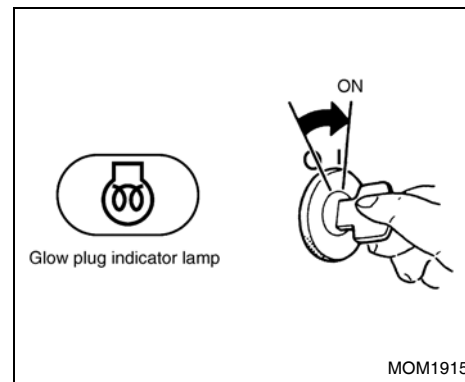

DIESEL ENGINE

Starting

1. Set the parking brake lever and move the selector lever to the neutral position.
2. Depress the inching brake pedal as far as it can go.
3. When the ignition key is set to the ON position, the glow plug indicator lamp on the instrument panel illuminates, indicating that engine preheating has started.

Keep the ignition key in the ON position until the glow plug indicator lamp turns off (indicates completion of preheating).

NOTE (QD32 engine):

Engine preheating is controlled automatically corresponding to the engine coolant temperature, atmospheric air temperature, etc., and the glow plug indicator lamp turns off when the engine is preheated to the specified temperature.

4. When the glow plug indicator lamp has turned off, turn the ignition key to the START position while fully depressing the accelerator pedal, until the engine starts.

NOTE (for diesel engines only):

- Do not operate the starter for more than 30 consecutive seconds.
 - If the engine does not start even after operating the starter 3 times for approximately 5 seconds, turn the ignition key to the OFF position and then wait for about 30 seconds. Subsequently, try to start it again from the preheating process.
5. After the engine has started, release the accelerator pedal gradually and then perform warm-up of engine.

NOTE:

- When restarting, return the ignition key to the OFF position once, and then turn it to the START position.
- Regardless of the atmospheric temperature, always perform warm-up for approximately 5 minutes. During warm-up, check for any malfunction of meters, warning lights or indicator lamps.
- Failure to properly warm up the engine can cause degradation and shortened life of engine.
- When it is not necessary to preheat the engine because of high engine coolant temperature immediately after it stops or for some other reasons, the engine can be started by turning the ignition switch to the START position before the glow plug indicator lamp turns off.
- If the glow plug indicator lamp is not illuminated, malfunction may exist. In this case, promptly contact your supervisor for measures or contact an authorized UniCarriers FORKLIFT dealer to inspect the forklift.

Stopping

To stop the engine, turn the ignition key to the OFF position.

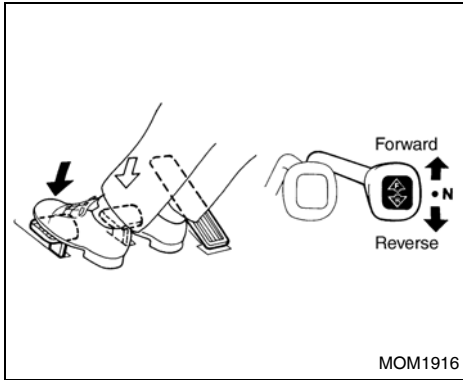

GEARSHIFT LEVER

MT vehicle FORWARD-REVERSE lever and GEARSHIFT lever

The "FORWARD-REVERSE" lever is used to make a directional change.

1. Release the accelerator pedal.
2. Foot the brake pedal, to fully depress the clutch pedal immediately before the forklift stops.
3. Further depress the brake pedal, to completely stop the forklift.

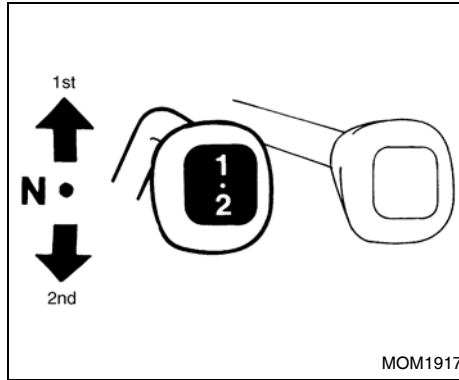

4. When the forklift completely stops, position the forward-reverse lever in forward or reverse.

CAUTION:

While the forklift is moving, do not change over the forward-reverse lever positions. Otherwise, the transmission may be damaged.

The "GEARSHIFT" lever permits selection of different transmission gear ratios.

1. Simultaneously with the release of accelerator pedal, fully depress the clutch pedal.
2. Change the gear shift from 1st to 2nd or from 2nd to 1st.

3. When the gear shift is positioned in the desired place, foot the accelerator pedal while gradually releasing the clutch pedal.

CAUTION:

Positioning the gear shift in 1st without decelerating the forklift may cause a gear shift shock, resulting in dropped loads or damaged transmission.

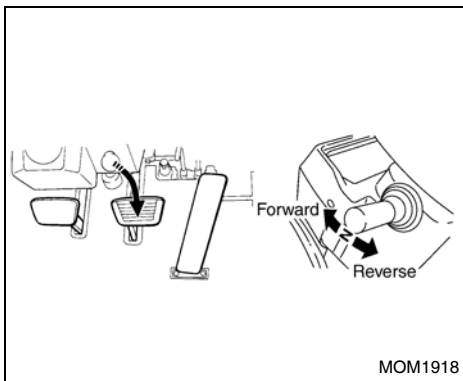

AUTOMATIC TRANSMISSION MODELS



WARNING:

Automatic transmission models do not have the creeping phenomena.



CAUTION:

While the forklift is moving, do not change over the selector lever positions. Otherwise, the transmission may be damaged.

1. When starting the forklift from the stopped condition

When the selector lever is in the neutral position:

- The forklift does not move regardless of whether accelerator is depressed or not.

When the selector lever is in the F (forward) or R (reverse) position:

- The forklift starts moving when the accelerator pedal is depressed.
- The forklift does not move if the accelerator pedal is not depressed.

2. While driving the forklift

When the selector lever is in the F or R position:

- The forklift continues accelerating by depressing the accelerator pedal.
- When the accelerator pedal is released.

The engine brake is applied with the clutch engaged if the forklift speed is above 6.5 km/h (4.5 MPH) for 3 seconds.

The clutch disengages to the neutral position if the forklift speed is below 6.5 km/h (4.5 MPH) for 3 seconds.

When the selector lever is in the neutral position:

- The lever is in the neutral position independent of the forklift speed.

3. Inhibitor function

When the selector lever is in the F (forward) or R (reverse) position, it is not possible to start the engine.

4. Precautions

- This forklift has no creeping phenomena.
- The forklift will not move if the selector lever is in the F or R position unless you depress the accelerator pedal. When depressing the accelerator pedal, be sure to visually confirm the position of the selector lever.
- When starting on slopes, be sure to apply the parking brake to hold the forklift and then start, even if the slopes are gentle.
- Avoid rapid acceleration (especially when carrying a high load).

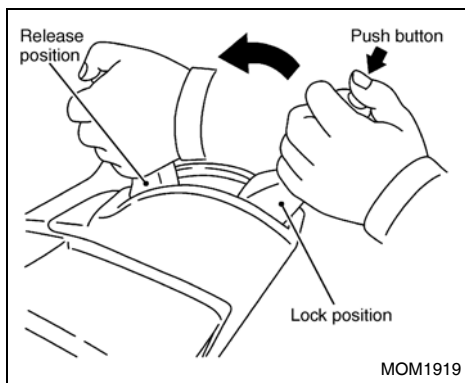

PARKING BRAKE LEVER

To set the brake, pull the parking brake lever backward. To release the brake, press the button and then push the parking brake lever forward. Before leaving the forklift, be sure to apply the parking brake securely.



WARNING:

Always depress the brake or inching pedal before releasing the parking brake to avoid movement of the forklift before selecting a direction.

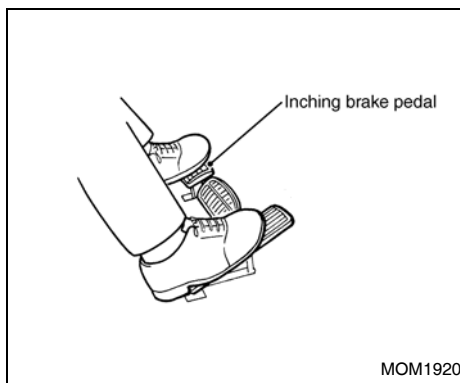

INCHING BRAKE PEDAL

1. Fully depress the inching brake pedal.
2. Move the selector lever to the forward or reverse position.
3. Depress the accelerator pedal little by little. At the same time, gradually releasing the inching brake pedal moves the forklift bit by bit.



WARNING:

- When the inching/brake pedal is fully depressed the service brake will be applied. However the inching/brake pedal should not be used as the method for stopping the forklift. In normal traveling operations, the inching/brake pedal should only be used during loading, or unloading, which requires short, controlled movement of the forklift.
- During deceleration on any grade, only use the brake pedal or an increase or decrease in speed by using the accelerator. Do not use or depress the inching pedal because this would put the transmission in the neutral mode.

LOAD CONTROL LEVERS

To control the loading mechanism for moving the fork up and down and tilting the mast forward and backward, there are two operating methods: 2-lever type or 1-lever type.

Before using the forklift, make sure which operating lever type is adopted in controlling the loading mechanism and thoroughly read the related instruction manual.

WARNING:

- Always sit in the operator's seat when operating the lever.
- Operating the control lever without properly sitting on the operator's seat causes the loading interlock warning lamp to blink and the loading mechanism to be inactive.
- Before operating the lever, make certain that the surrounding area is clear and it is safe to proceed.
- If the engine is stopped, operation of the lever to the downside or lowering direction may cause the fork and mast to go down due to its own weight or the cargo that may be on the forks. This may result in serious damage or injury.
- Always avoid any abrupt or sudden lever operation that may cause loads to shift or fall off fork or cause the forklift to become unbalanced and tip over.

2-lever type

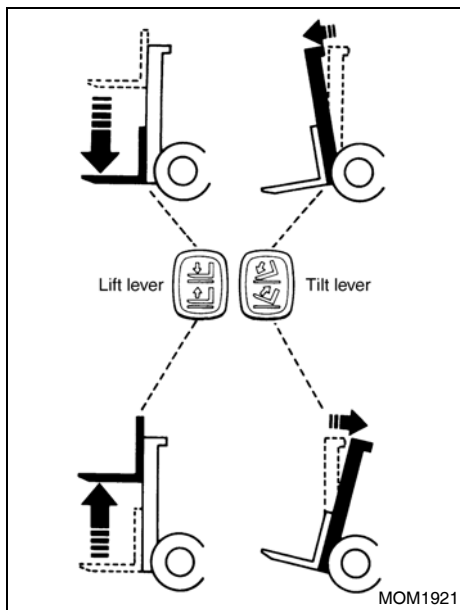

This method uses 2 levers: a lift lever for moving the fork up and down and a tilt lever for tilting the mast forward and backward:

- Lift lever:
Lift: Pull the lever to the operator side.
Lower: Push the lever forward.

- Tilt lever:
Forward: Push the lever forward.
Backward: Pull the lever to the operator side.

WARNING:

- Do not perform forward tilt while raising the forks, as this may cause loads to shift or fall, which could affect the stability of the forklift.
- Do not perform forward tilt while lifting loads in higher positions. This may cause loads to shift or fall, which could affect the stability of the forklift.

NOTE:

- Control of lifting speed:
Can be changed by controlling the tilt angle of the lever and by how much the operator depresses the accelerator pedal.
- Control of lowering speed:
Can be changed only by controlling the tilt angle of lever. Do not depress the accelerator pedal.
- Control of forward and backward tilting speeds:
For both forward and backward tilts, the speed can be changed by controlling the tilt angle of the lever and by how much the operator depresses the accelerator pedal.

1-lever type

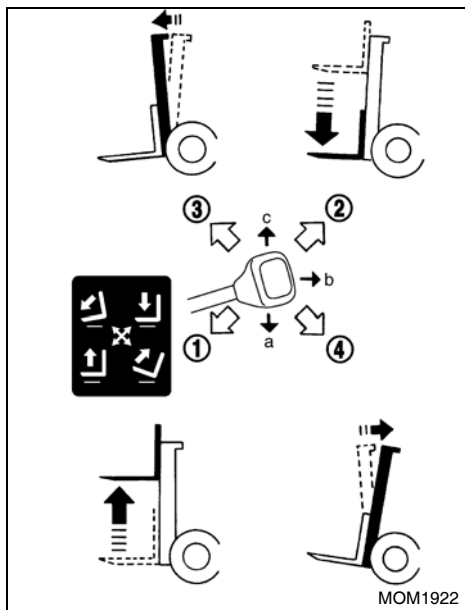

This method performs up and down movements of the fork and forward and backward tilting of mast using 1 lever:

- ① Lift: Diagonally pull the lever to the left side of the operator.
- ② Lower: Push the lever in the right forward direction.

③ Forward: Push the lever in the left forward direction.

④ Backward: Diagonally pull the lever to the right side of the operator.

Simultaneous operations are also allowed by combining up and down movements and forward and backward tilts.

This may be done by moving the lever into the a, b or c position.

a: Backward tilt while lifting:
Pull the lever to the center of the operator side.

b: Backward tilt while lowering:
Turn over the lever to the right side of the center.

c: Forward tilt while lowering:
Push the lever in the center forward direction.



WARNING:

Do not perform forward tilt while raising the forks, because this may cause loads to shift or fall, which could affect the stability of the forklift.

NOTE:

- **Control of lifting, forward tilting and backward tilting speeds:**
Can be changed by controlling the tilt angle of the lever and by how much the operator depresses the accelerator pedal.
- **Control of lowering speed:**
Can be changed only by controlling the tilt angle of the lever. Do not depress the accelerator pedal.

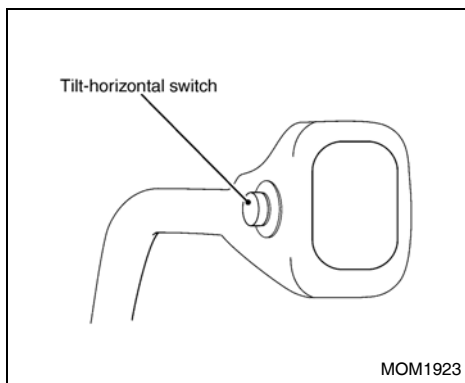

TILT-HORIZONTAL SWITCH (option)

When forward tilt is performed with the mast tilted backward, the forward tilt operation can automatically be stopped in the position where the fork is level.

Performing forward tilt while pressing the tilt-horizontal switch moves the mast as shown in the following list, depending on the loading condition.

Loading condition	Forward tilt operation of mast
Without load	Automatically stops in the horizontal fork position.
With load	<ul style="list-style-type: none"> • No automatic forward stop to horizontal • No movement when turning on the tilt-horizontal switch

With load: Turning on the tilt-horizontal switch during operation will not automatically stop tilt in the horizontal direction (no movement).

NOTE:

- In case of 2-lever method, the tilt-horizontal switch is attached to the tilt lever.
- The tilt-horizontal switch is kept on while pressed and turned off when released.
- Unless the tilt-horizontal switch is pressed, normal forward and backward tilt operations are performed.



CAUTION:

The horizontal fork position allowing automatic stops requires a position parallel to the road surface. Do not use this function if the road surface is not level.

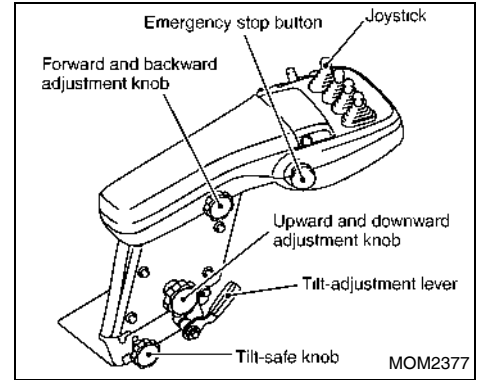
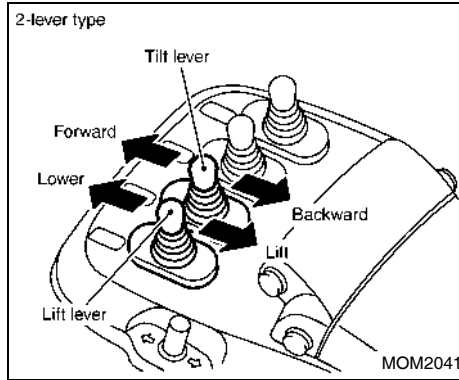
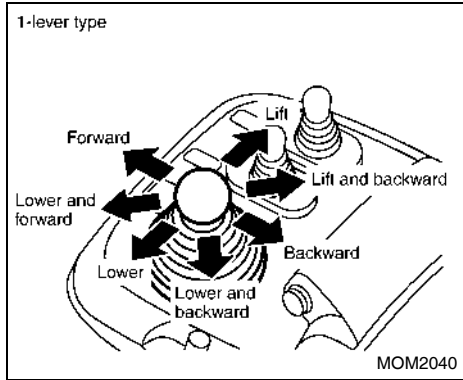

JOYSTICK CONTROL LEVER TYPE (option) (2 ton, 2W MAST only)

The joystick lever is an electrically controlled type. The cargo handling operation can be performed only when the ignition switch is turned on.



WARNING:

Do not perform forward tilt while raising the forks. Otherwise, dropped loads or an unbalanced forklift may cause the forklift to fall down.

NOTE:

- Before the ignition switch is turned on, make sure that the joystick lever is set to the neutral position. If the lever is placed in any position other than the neutral position, cargo handling or fork operation cannot be performed.

- When the ignition switch is turned off, the fork does not lower even under its own weight.
- The joystick lever is used to tilt the mast forward or backward and to lift or lower the forks. Cargo handling speed (lift, lower, forward and backward) can be adjusted by the distance that the lever is moved.
- For detailed joystick lever operation, refer to the illustration above.

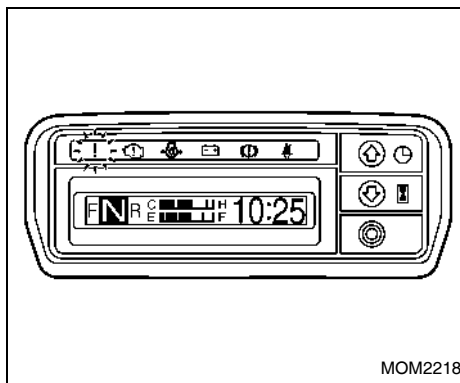
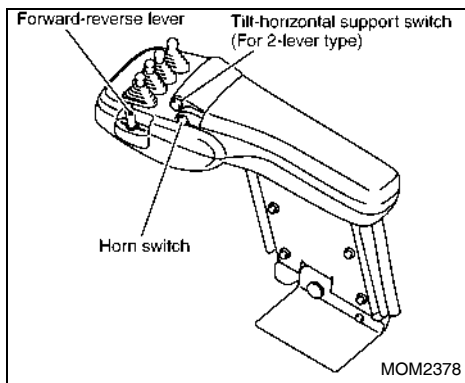

WARNING:

The warning mark **!** and a malfunction message will appear on the meter when the joystick control system malfunctions. When this occurs, immediately stop cargo handling operations and have the forklift checked and repaired by an authorized UniCarriers FORKLIFT dealer.

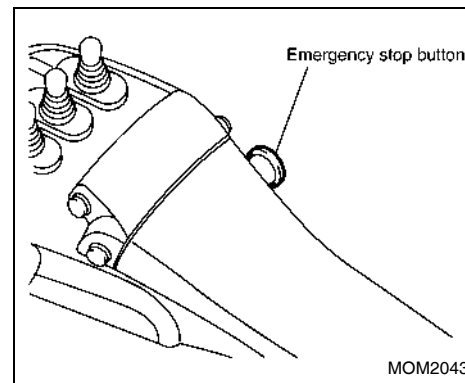

WARNING:

If an erroneous cargo handling operation is noticed regardless of the joystick lever position, press the emergency stop button on the console box, stop cargo handling operations and have the forklift checked and repaired by an authorized UniCarriers FORKLIFT dealer. (To release the emergency stop button, turn it in the direction indicated by the arrow.)

TRAVELING

While traveling, the mast should be tilted back and the forks lowered to approximately 200 mm (8 in) above the ground.



WARNING:

1F1/1F2 models do not have the creeping phenomena.

- **The forklift will not move if the selector lever is in the F or R position unless the operator depresses the accelerator pedal. When depressing the accelerator pedal, be sure to visually confirm the position of the selector lever.**
- **When starting on slopes, be sure to apply the parking brake to hold the forklift and then start, even if the slopes are gentle.**
- **Avoid rapid acceleration (especially when carrying a high load).**

TURNING

The smaller the radius of a turn to be made, the lower the speed of the forklift should be. When making a sharp turn, always drive the forklift at a low speed.



WARNING:

- **Because the movement of a forklift is different from that of a passenger vehicle, always reduce speed while making turns to ensure that the forks and counterweight will clear objects during the turn. Turning at a high speed could result in loss of control and a potential lateral tip-over.**
- **Do not make a turn with the fork lifted high or at a high speed. This could result in a loss of control and potential tip-over.**

CLIMBING

For safety reasons, when driving a loaded forklift up a steep grade, it must be driven forward with the load in front; on a downgrade, backward, with the load behind.

On a UniCarriers FORKLIFT equipped with an automatic transmission, standing starts and stopping on a slope can be accomplished by manipulating the accelerator and brake pedals as required.

For stopping, the brake pedal should be used at all times.

For traveling, depress the accelerator pedal. To make a standing start on a slope, the parking brake can be used instead of the brake pedal.

STOPPING AND PARKING

To stop the forklift, remove your foot from the accelerator pedal and depress the brake pedal.



WARNING:

- Do not make sudden stops because the forklift may pitch forward and drop the load.
- When leaving the forklift, set the parking brake, adjust the mast to an upright position, lower the forks until they rest on the ground and turn off the ignition switch.

NOTE:

- If the operator leaves the operator's seat without pulling the parking brake lever, the warning buzzer alerts the operator.
- If the operator is more than 7.6 m (25 ft) from the forklift or moves out of sight of the forklift, the key should be removed.

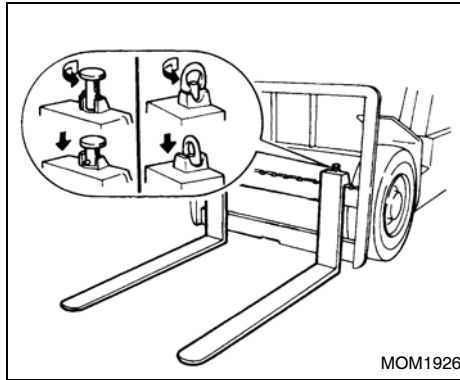

FORKS

The fork-to-fork distance can be properly adjusted by unlocking the lock pins on the forks. These pins are unlocked by pulling them up and turning them 90° in either direction. Forks must be equally located from the center of the forklift. After the correct fork-to-fork distance is obtained, secure the forks with the lock pins.

NOTE:

Various kinds of forks are available depending on the lifting capacity. Select the proper forks so that the specifications stamped on the side face of them will meet the lifting capacity of your forklift. Do not use forks with specifications that are below the lifting capacity of your forklift.



WARNING:

Forks should be inspected daily for any damage, bending or other malfunctions. Report any conditions to your supervisor.

LOADING AND UNLOADING

LOADING

Adjust the distance between the forks so that they are at or near the same distance from the centerline of the forklift. The wider the interval between forks, the better the balance. Be sure to apply the fork latches after setting the forks. (Refer to page 60.)

Approach slowly, straight toward the load, and stop just in front of it. Adjust the mast to the vertical position, matching the height of the forks to the position of the pallet. Advance slowly and completely insert forks beneath the load. Set the selector lever to the neutral position and apply the parking brake. Then raise the load. Confirm that the load is stable and tilt it backward. Release the parking brake and back up the forklift slowly.

TRANSPORTATION

When transporting loads, the forklift should be driven carefully at a slow speed with the load kept low and tilted back. When the load is big enough to block forward visibility, drive the forklift backward. Follow the safety rules.

UNLOADING

Slowly approach the unloading site and stop facing straight ahead.

Move the selector lever into the neutral position and apply the parking brake. After adjusting the mast to the vertical position, raise the load a little above the stack on which it is to be placed. Release the parking brake and advance slowly into the proper position for stowing. Apply the parking brake and place the selector lever in the neutral position.

Slowly lower the forks to set down the load. After moving the selector lever to the reverse position, release the parking brake and back up the forklift until the forks separate completely from the load.

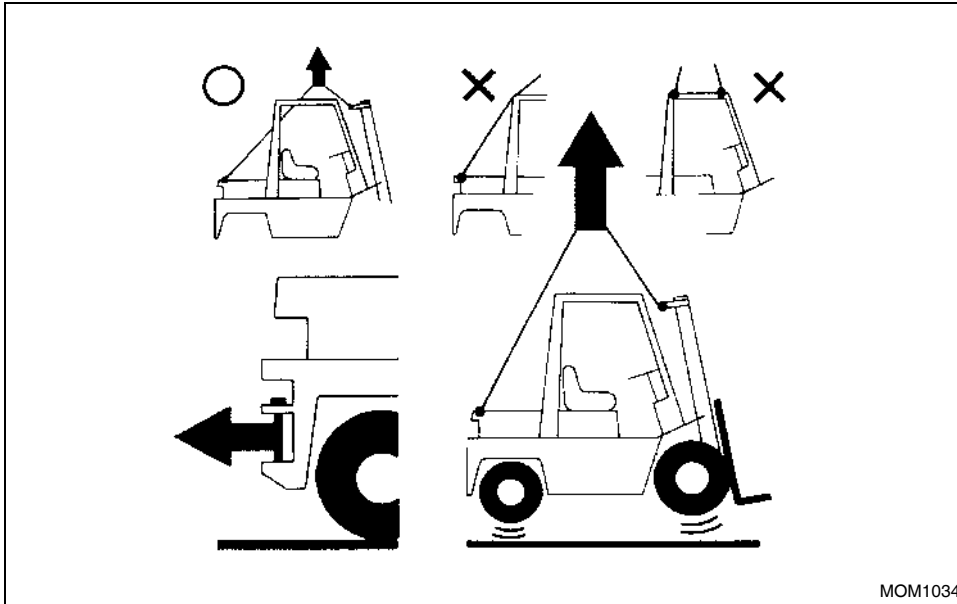

MOM1034

LIFTING UP FORKLIFT



WARNING:

Only use this method as a last resort to move the forklift if the normal work application requires repeated lifting. Permanent lifting devices must be mounted on the forklift by UniCarriers Corporation. Contact an authorized UniCarriers FORKLIFT dealer for more details.



WARNING:

- Make sure that the wire ropes do not interfere with the overhead guard while lifting the forklift.
- Make sure that the wire ropes and lifting device are strong enough to support the forklift safely, because the forklift is extremely heavy.
- Do not use the cab frame (overhead guard) to lift up the forklift.
- Do not get under the forklift while lifting the forklift.

When lifting the entire forklift, secure wire ropes to the holes located on both sides of the outer mast cross beam and to the hook on the counterweight, and then utilize a lifting device.

FUNCTION TESTS

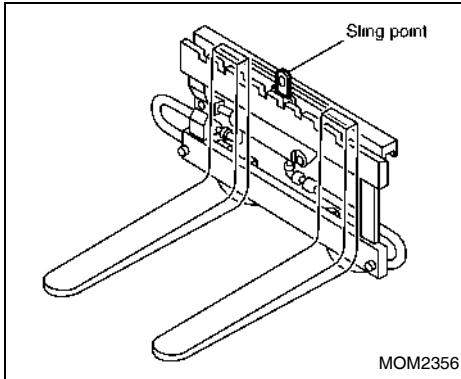

This illustration shows the sling point of the attachments which are possible to be installed and removed.

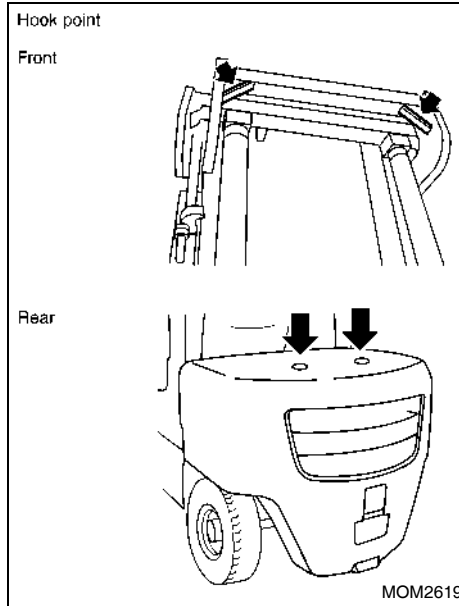

The functional tests are performed to check whether the forklift functions correctly after it has been transported (over land or water), or after it has been taken out of storage.

The test covers the following items, but since exclusive tools and equipment are required for Items 1 and 2, request that an authorized UniCarriers FORKLIFT dealer perform the test.

Items

1. Those that are indicated in daily care.
2. Dynamic tests

2-1) Mobility (traveling and maneuvering) test

Make sure that the forklift moves in the direction specified by the selector lever, and that the forklift operates correctly when the parking brake lever is locked or released. Also check to make sure that the steering feels normal and that it operates satisfactorily.

Elevate and lower test load.

2-2) Stacking test

Raise the test load to the maximum height of the mast and lower at the maximum speed, stopping the descent several times, to make sure that it stops smoothly.

2-3) Lowering speed test

Check to make sure that the maximum lowering speed does not exceed 0.6 m/s (2.0 ft/s) (by measuring the speed).

3. Test for holding load

Check the rate at which the mast lowers naturally [100 mm (3.94 in)/10 min max].

Check the rate at which the tilt cylinder tilts forwards naturally (5 degrees/10 min max).

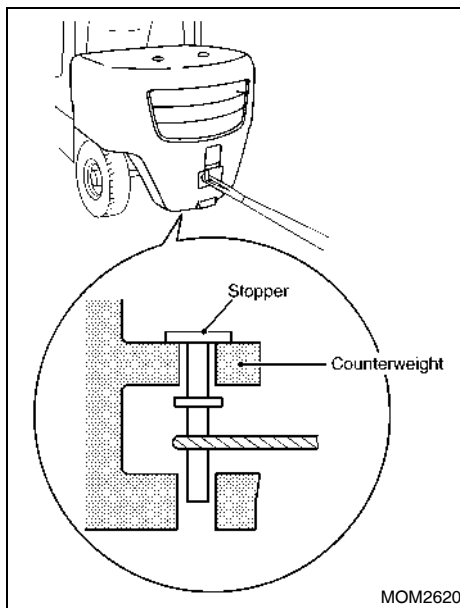

TRACTION BAR

Use the traction bar only when required to assist in pulling or dragging the forklift from a ditch or from being stuck.



WARNING:

Never use the traction bar for towing the forklift or other vehicles.



CAUTION:

- Always ensure that the traction bar is fully inserted until the stopper touches against the counterweight. This will reduce the possibility of the bar slipping.
- The traction bar is not a towing or drawing pin or coupling, and it should only be used for assistance in that type of operation.
- When using wire, cables or chains to pull or drag an object, ensure that all items are in good condition and are not damaged.
- Always gently draw towing cables or chains so as not to cause any shock, abrupt movements which could cause the traction bar to slip, bend or damage.
- If the traction bar or towing device slips, pulls out or becomes damaged, stop the towing operation and replace damaged parts or discontinue that type of operation.

SEAT (EXCEPT FOR EU REGION)

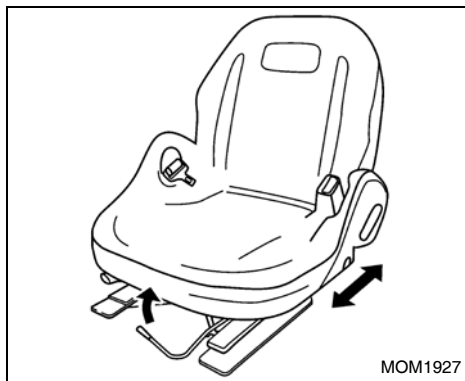

SEAT ADJUSTMENT

Forward and backward control lever

The forward and backward control lever is located at the front of the seat slider.

To adjust the seat position, pull the lever upward and hold it there while sliding the seat forward or backward to the desired position.

Release the lever to lock the seat.

Before operating the forklift, be sure that the seat is locked securely.



WARNING:

- Before adjusting the seat, turn the ignition key off.
- Be sure to adjust the seat position while the forklift is stationary.

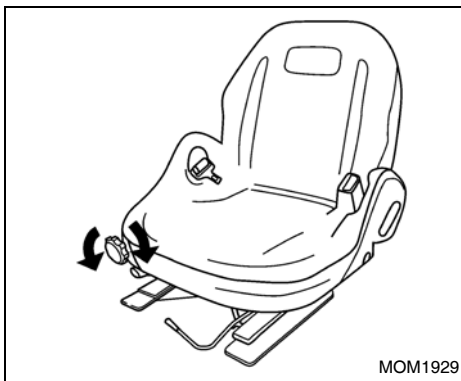

Suspension seat operator's weight adjustment

Adjust the suspension seat to the operator's weight by turning the weight adjustment dial at the front right side of the seat.

Optimum fine adjustment for operating surface conditions is also possible.

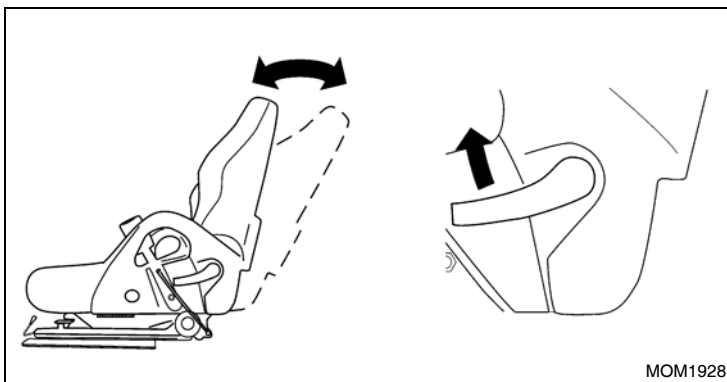

MOM1928

Backrest inclination adjustment

Adjust the backrest to the desired angle while pulling the lever located to the left of the seat. Release the lever to lock the backrest.



WARNING:

- Do not excessively tilt back the backrest, otherwise the seat belt may not demonstrate its performance in an emergency.
- When adjusting the angle of the backrest, gently do it while holding the backrest by hand. Hasty and rough adjustment may cause an injury, for instance the back of the seat may bump against the operator's face and body, or the operator's finger may get caught between the backrest and the grip.

NOTE:

- The backrest can be tilted forward depending on the situation. The tilting manner is the same as tilting backward, but it cannot be fixed at an optional position.
- A seat pocket and magazine rack are on the back side of the backrest.

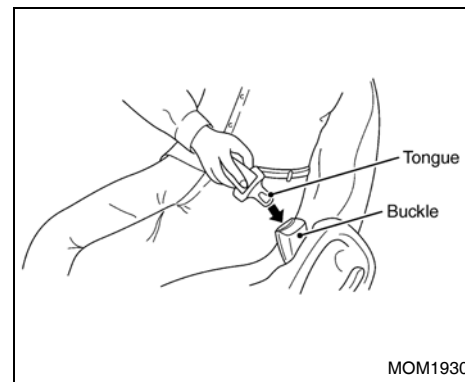

MOM1930

Seat belt

1. Holding the tongue, pull out the seat belt gently.
2. Wrap the lower part of the hipbone with the seat belt as tight as possible.

NOTE:

If the seat belt cannot be pulled out because it is locked, loosen it once and pull it out once more.

3. Being careful not to twist the seat belt, insert the tongue into the buckle until it clicks.
To unfasten the seat belt, press the button on the buckle and pull the tongue out of it. While lightly holding the tongue, let the seat belt be rewound gently.

NOTE:

When unfastening the seat belt, be sure to hold the tongue because the tongue may be rapidly pulled together with the seat belt.



WARNING:

- Check the seat belt condition for the following points.
 - Cut or frayed strap
 - Worn or damaged hardware including anchor points
 - Buckle or retractor malfunction/Loose stitching
- Tightly wrap the seat belt around the hipbone as low as possible. If the seat belt comes off the hipbone and it wraps around the abdomen, it may cause an injury because strong pressure is applied onto the abdomen.
- Do not fasten the seat belt if it is twisted. If it is twisted, it may cause an injury because the twisted belt cannot disperse an impact and a limited part is shocked intensively.
- Do not adjust the seat belt to be loose such as slackening it intentionally by use of a clip. If the seat belt is fastened loosely, it cannot function to its full performance.
- Do not excessively tilt back the backrest, otherwise the seat belt may not function to its full performance.
- Do not put any foreign substance into the buckle or belt winder, otherwise it cannot function to its full performance because it cannot be fastened normally.
- If the seat belt is used by a pregnant woman or sick person, consult with a doctor beforehand because her/his abdomen is pressed by the seat belt.
- A seat belt that has been impacted, damaged or broken in part may not function to its original performance. Replace it with a new one at an authorized UniCarriers FORKLIFT dealer.
- For cleaning the seat belt, use a neutral detergent or lukewarm water. After cleaning, dry it completely before use. Be sure not to use an organic solvent such as benzine or gasoline, otherwise the seat belt deteriorates in its performance and may not function as designed.
- UniCarriers Corporation recommends that injured persons use seat belts. Check with your doctor for specific recommendations.
- Periodically check to see that the seat belt and metal components, such as buckles, tongues, retractors, flexible wires and anchors, work properly. If loose parts, deterioration, cuts or other

damage on the webbing is found, the entire seat belt assembly should be replaced.

SEAT (FOR EU REGION)

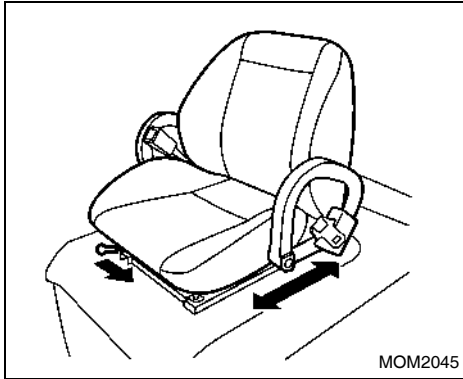

SEAT ADJUSTMENT

Forward and backwards control lever

The forward and backwards control lever is located at the front of the seat slider.

To adjust the seat position, pull the lever upward and hold it there while sliding the seat forward or backward to the desired position.

Release the lever to lock the seat.

Before operating the forklift, be sure the seat is locked securely.



WARNING:

- Before adjusting the seat, turn the ignition switch to the OFF position.
- Be sure to adjust the seat position while the forklift is stationary.

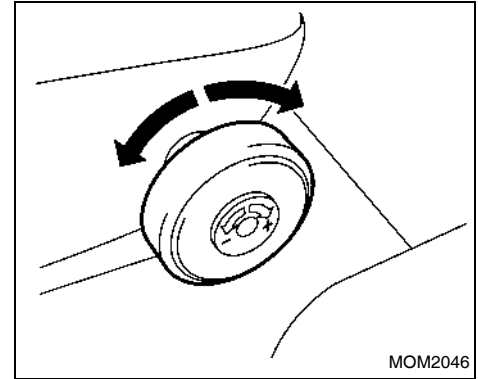

Suspension seat operator's weight adjustment

Adjust the suspension seat to the operator's weight by turning the weight adjustment dial at the front right side of the seat.

Optimum fine adjustment for operating surface conditions is also possible.

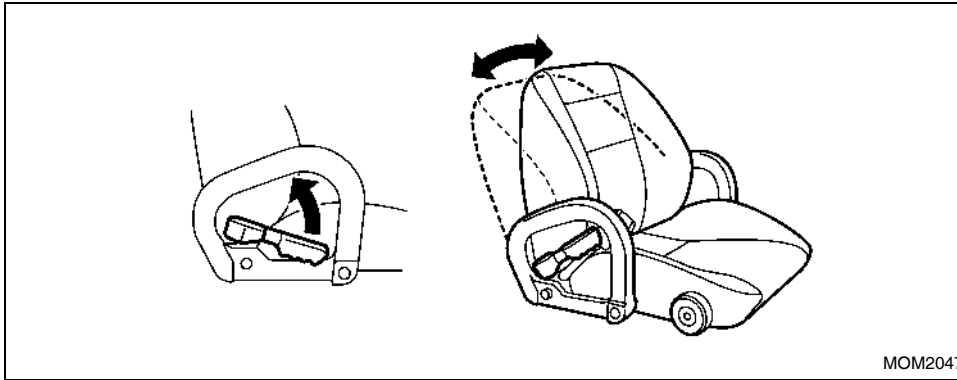

Backrest inclination adjustment

Adjust the backrest to the desired angle while pulling the lever located to the right of the seat. Release the lever to lock the backrest.



WARNING:

- Do not excessively tilt back the backrest, otherwise the seat belt may not demonstrate its performance in an emergency.
- When adjusting the angle of the backrest, gently do it while holding the backrest by hand. Hasty and rough adjustment may cause an injury, for instance the back of the seat may bump against the operator's face and body, or the operator's finger may get caught between the backrest and the grip.

NOTE:

- The backrest can be tilted forward depending on the situation. The tilting manner is the same as tilting backward, but it cannot be fixed at an optional position.
- There is a seat pocket for the operators manual, maintenance manual and other documents on the rear side of the backrest.

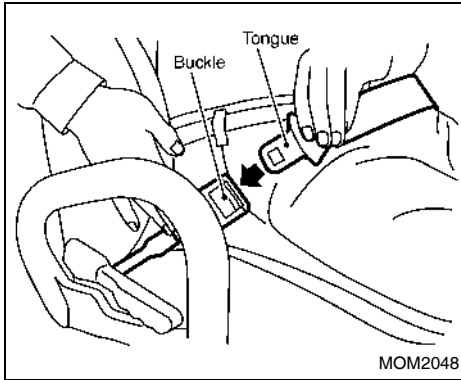

SEAT BELT

1. Holding the tongue pull out the seat belt gently.
2. Wrap the lower part of the hipbone with the seat belt as tight as possible so as not to get loose.

NOTE:

If the seat belt cannot be pulled out because it is locked, loosen it once and pull it out once more.

3. Being careful not to twist the seat belt, insert the tongue into the buckle until it “clicks”. For unfastening the seat belt, press the button on the buckle and pull the tongue out of it. While lightly holding the tongue, let the seat belt be rewound gently.

NOTE:

When unfastening the seat belt, be sure to hold the tongue because the tongue may be pulled rapidly together with the seat belt.



WARNING:

- Check the seat belt condition for the following points.
 - Cut or frayed strap
 - Worn or damaged hardware including anchor points
 - Buckle or retractor malfunction/Loose stitching
- Tightly wrap the seat belt around the hipbone as low as possible. If the seat belt comes off the hipbone and it wraps around the abdomen, it may cause an injury because strong pressure is applied onto the abdomen.
- Do not fasten the seat belt as it is twisted. If it is twisted, it may cause an injury because the twisted belt cannot disperse an impact and a limited part is shocked intensively.
- Do not adjust the seat belt to be loose such as slackening it intentionally by use of a clip. If the seat belt is fastened loosely, it cannot demonstrate its performance.
- Do not excessively tilt back the backrest, otherwise the seat belt may not demonstrate its performance.

- Do not put any foreign substance into the buckle or belt winder, otherwise its performance cannot be demonstrated because it cannot be fastened normally.
- If the seat belt is used by a pregnant woman or sick person, consult with the doctor beforehand because her/his abdomen is pressed by the seat belt.
- The seat belt that was once impacted, damaged or broken in part may not demonstrate its original performance. Replace it with a new one at the nearest UniCarriers FORKLIFT dealer.
- For cleaning the seat belt, use a neutral detergent or lukewarm water. After cleaning, dry it completely before use. Be sure not to use an organic solvent such as benzine or gasoline, otherwise the seat belt deteriorates in its performance and may not function as designed.
- UniCarriers Corporation recommends that injured persons use seat belts. Check with your doctor for specific recommendations.
- Periodically check to see that the seat belt and metal components, such as buckles, tongues, retractors, flexible wires and anchors, work properly. If loose parts, deterioration, cuts or other damage on the webbing is found, the entire seat belt assembly should be replaced.

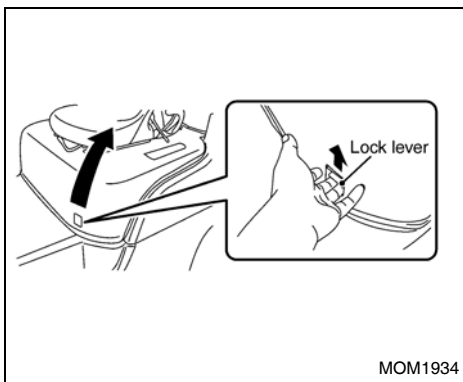

TOP PANEL

The top panel can be opened toward the rear of the forklift.



WARNING:

The top panel is automatically retained by the gas stay.

Open operation

1. Tilt the steering wheel all the way forward and upward. Use the service release latch (yellow) lever. Refer to page 75.
- For LPG & dual fuel units with swing down or out LPG tank mounting, you must swing out (down) the LPG tank before opening the top panel.
- For forklift equipped with joystick
To open top panel
Before the top panel is opened, tilt the joystick control unit.
2. Pull the lever on the left side of the operator's seat upward to tilt the backrest forward.
3. Push the lever in the front left side of the top panel upward to unlock the top panel, and lift the top panel rearward while pushing the lever.

NOTE:

- For opening the top panel rearward, refer to the Top Panel Open Procedure Label on the body.
- Before opening the top panel, swing-open the LPG cylinder as illustrated later in this section.

Close operation

1. Make sure that the steering wheel is leapt up.
2. Depress the top panel. Since there is reaction of the gas stay, depress the top panel while pressing its front top until it is completely locked.
3. Raise the backrest of the operator's seat up to the original position.
4. Pull the steering wheel toward the operator's side to the limit so that it is locked.
- For forklift equipped with joystick
To close top panel
Return the joystick control unit to the original position.



WARNING:

- To avoid pinching your fingers, always grasp the handle when closing the top panel.
- On forklifts equipped with a top panel lock, make sure the top panel is securely locked.

TOP PANEL LOCK



WARNING:

Do not open the top panel with the engine running. Do not place hands near the cooling fan because it rotates at a high speed and may cause injury. When opening the hood, be sure to turn off the engine. When starting the engine, check the hood to make sure that it is locked.

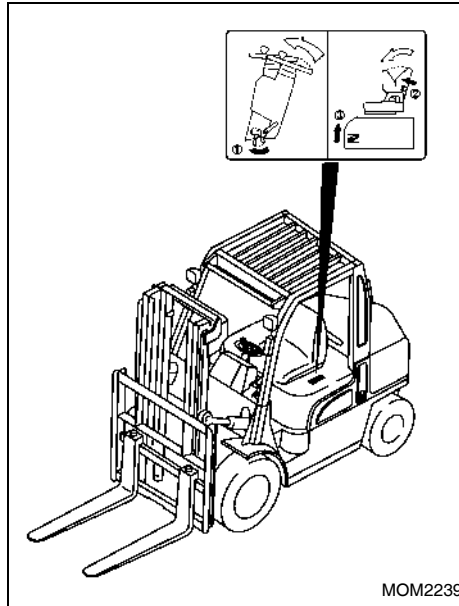

The forklift is provided with a top panel lock to ensure that the engine hood cannot be opened unless the lock is canceled.

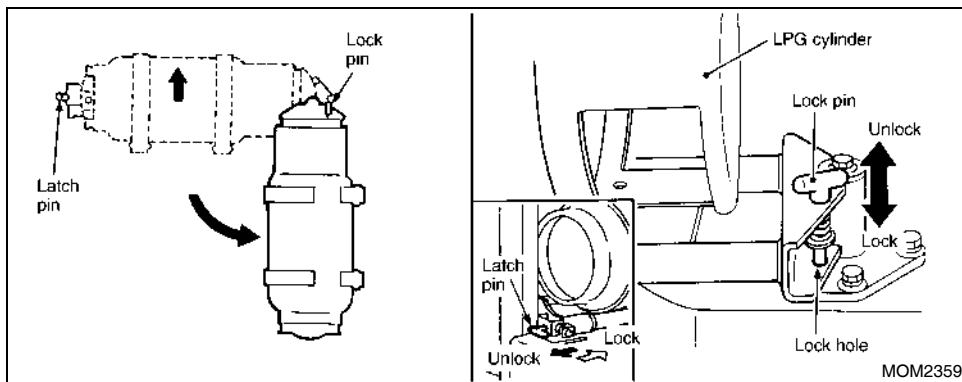

LPG CYLINDER HOLDER OPENING PROCEDURE

1. Pull out the latch pin to unlock the LPG cylinder holder. Slowly open the LPG cylinder holder.
2. Insert the lock pin into the lock pin hole.
3. Perform the top panel opening procedure.



WARNING:

Before opening the top panel, make sure that the lock pin is properly inserted into the lock pin hole.

LPG CYLINDER HOLDER CLOSING PROCEDURE

Before closing the LPG cylinder holder, make sure that the top panel is properly closed.

1. Pull out the lock pin. Slowly close the LPG cylinder holder, and then lock with the latch pin.



WARNING:

Make sure that the latch pin is properly locked.

2. While seated in the operator's seat, turn the ignition switch on.
3. Check to make sure that the cylinder lock indicator light is off.

4. If the light is illuminated, turn the key off and check that the swing mount is secured and locked.
5. Check to see if the switch is damaged.



WARNING:

Only authorized UniCarriers FORKLIFT service technicians should perform repair and/or adjustment to the switch or latch.

Refer to pages 111 to 126 for additional information on the LPG - gasoline dual fuel forklift.

Top panel closing procedure:

1. Make sure that the steering wheel is tilted upward.
2. By pressing on the front of top panel, completely close until latched.
3. Raise the backrest of the operator's seat up to the original position.
4. Pull the steering wheel toward the operator's seat to the limit so that it is locked.



WARNING:

- Keep fingers clear when closing the top panel.
- On forklifts equipped with a top panel lock, make sure that the top panel is securely locked.

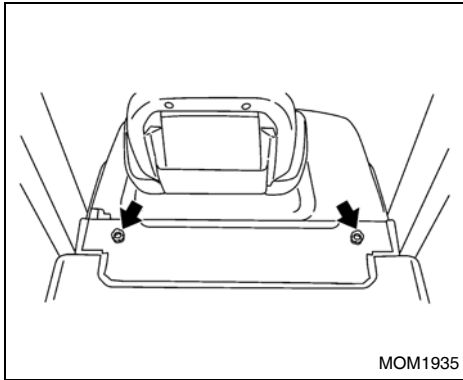

RADIATOR COVER

The radiator cover can be removed with the top panel closed.

For inspection of the radiator or replenishment of the engine coolant (cooling water), loosen the right and left bolts by hand.

NOTE:

- Be absolutely sure to hand tighten the bolts when reinstalling the radiator cover.
- Refer to page 83 for information on the engine coolant level check procedure.

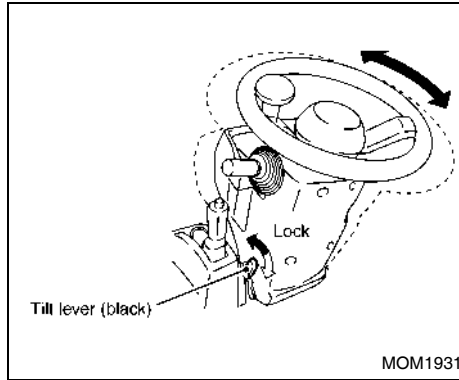

STEERING WHEEL

Tilt adjustment

The position of the steering wheel can be adjusted. To adjust, push down on the tilt lever (black) located on the left side of the steering column, and move the wheel to the desired position. After selecting the wheel position, pull up on the lever fully to lock it in place.

WARNING:

- Before adjusting the steering wheel, turn the ignition switch off and set the parking brake.
- Be sure to adjust the steering wheel position while the forklift is stationary.
- After adjustment, try to move the steering wheel upward or downward to ensure that it is locked securely.

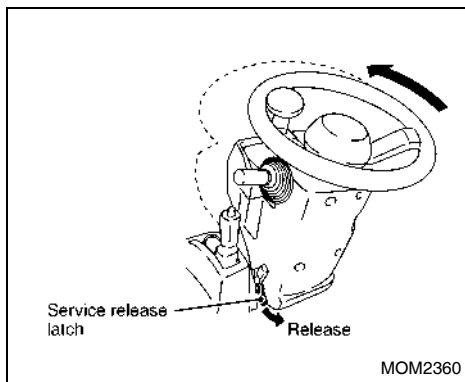

SERVICE RELEASE LATCH

Press the steering wheel forward while depressing the service release latch on the left side under the steering wheel, and the steering wheel tilts forward.

For returning the steering wheel to the original position, pull it toward the operator's seat to the limit. The service release latch returns to the original position and the steering wheel is locked automatically.

WARNING:

- Before starting the engine, make sure that the steering wheel is returned to the original locked position.
- Do not operate the forklift with the steering wheel in the service release position. Doing so could result in an accident.

NOTE:

The steering wheel position adjusted by the tilt mechanism does not vary when it is tilted.

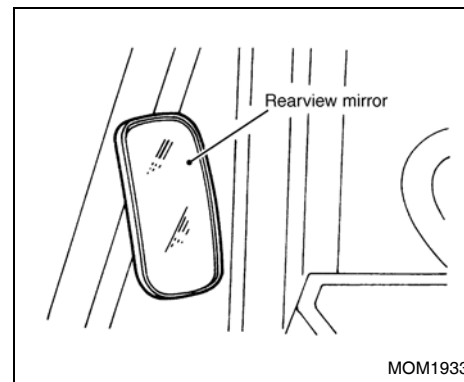

REARVIEW MIRROR

Adjust the right and left rearview mirrors respectively by hand so that both ensure the best view to the rear.

WARNING:

Never use only the rearview mirrors for operating the forklift in reverse due to limited visibility. Always turn and look in the direction of travel before proceeding.

PRECAUTIONS FOR COLD AND HOT WEATHER

In cold weather

● Oil and grease

Use engine oil and grease that are suitable for the ambient temperature. Refer to “RECOMMENDED LUBRICANTS” on page 96.

● Coolant

When coolant might freeze at a low ambient temperature, drain out the coolant completely. In such cold weather, a recommended 50/50 mix of antifreeze solution only should be put into the cooling system.

Antifreeze:

[Example]

Antifreeze			
Coolant capacity	0.8 liter (3/4 Imp qt, 7/8 US qt)	1.7 liters (1-1/2 Imp qt, 1-3/4 US qt)	2.5 liters (2-1/4 Imp qt, 2-5/8 US qt)
	-7°C (19°F)	-18°C (0°F)	-35°C (-31°F)

COOLING SYSTEM BLEEDING INSTRUCTIONS



WARNING:

- **Never remove the radiator cap when the engine is hot. Serious burns could be caused by high-pressure fluid or steam escaping from the radiator.**
- **Always ensure that the coolant is cooled down sufficiently before removing the radiator cap. When opening the radiator cap, wrap the cap with a shop cloth and turn the cap slowly to release the internal pressure.**

NOTE:

● **Use only Genuine Long-Life Coolant (LLC) with the proper mixture ratio for the working environment that the forklift will be used in.**

● **Engine coolant must be disposed of properly. Check your local regulations.**

1. Remove the radiator cover and open the engine hood. Remove the radiator cap.
2. Place an appropriate size container under the radiator. Open the drain cock of the radiator and extract the coolant.
3. After draining all of the coolant, securely close the drain cock.
4. Prepare coolant mixture referring to the antifreeze coolant capacity table.
5. With the radiator cap removed, locate the engine coolant system bleeder screw. The bleeder screw location varies depending on the model of the engine. This screw will either be located in the thermostat housing or on the top of the water pump. Refer to the following illustrations for the location of the bleeder screw.

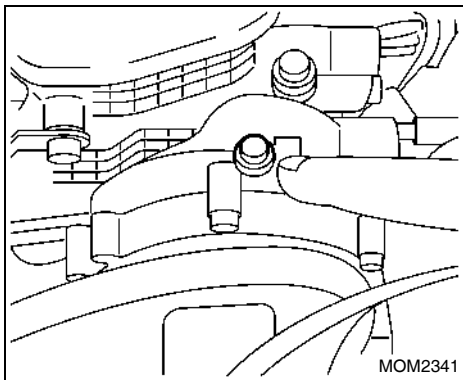
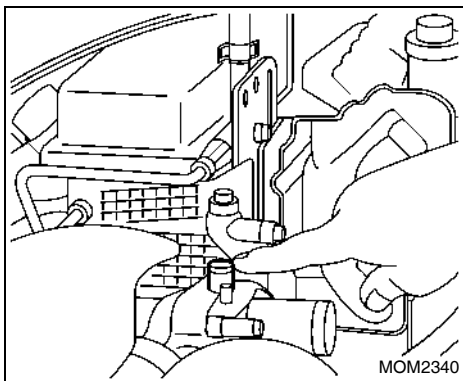

7. Add the recommended engine coolant mixture into the radiator, when the engine coolant comes out of the bleeder hole with no air bubbles. Install the bleeder screw and tighten to 6.3 to 8.0 N·m (55.7 to 75.8 in lbs) of torque.
8. Also add coolant to the reservoir tank up to the full line.
9. With the radiator cap removed, start the engine and accelerate above idle RPM to purge the air out of the LP vaporizer. Continue to operate the engine until the thermostat opens and you can visually see the coolant moving in the radiator.
10. Top off the coolant (approximately 25 mm (1 in) from the top of the radiator) in the radiator after all air has been purged.
11. Securely attach the radiator cap.
12. Turn off the engine.
13. Close the engine hood and install the radiator cover.
14. Start the engine, check for leaks and ensure that the engine temperature stays within the operating range. If the unit starts to overheat, there is still air in the cooling system. Repeat steps 5 to 14.

6. Completely remove the bleeder screw, and pay close attention to the sealing washer so that it does not fall off the screw as it is being removed.

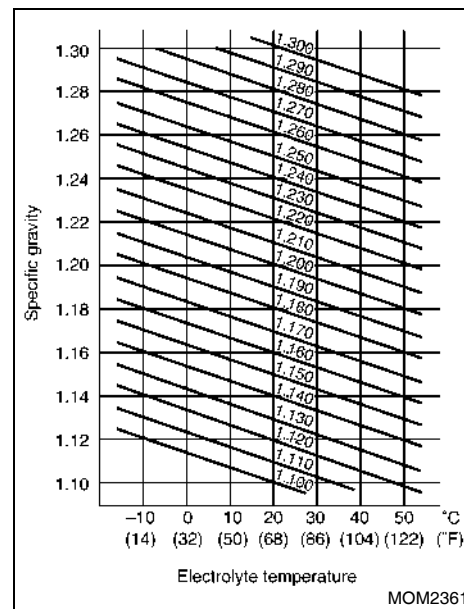

● Battery

The battery should not be left in the discharged state. When battery performance becomes questionable, check the specific gravity of the electrolyte, terminals of battery and alternator.

The normal specific gravity is 1.260 as corrected at 20°C (68°F). It changes about 0.0007 for every 1°C (1.8°F). If the specific gravity of the electrolyte does not indicate the correct value, charge the battery soon.

PROCEDURE FOR JUMP STARTING ECCS ENGINES



WARNING:

Always follow the instructions below. Failure to do so could result in damage to the charging system and cause personal injury.

1. If the booster battery is in another forklift, position the two forklifts to bring their batteries near each other.

Do not allow the two forklifts to touch.

2. Apply the parking brake. Shift the transmission into the N (Neutral) position. Switch off all unnecessary electrical systems (lights, etc.).
3. Remove the vent caps on the battery (if so equipped). Cover the battery with an old cloth to reduce explosion hazard.
4. Connect jumper cables in the sequence illustrated (A, B, C, D).

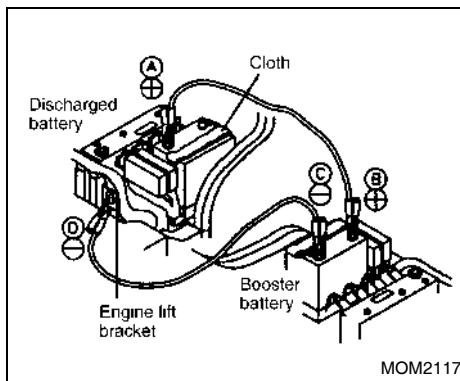

CAUTION:

- Always connect positive (+) to positive (+) and negative (-) to body ground (for example, strut mounting bolt, engine lift bracket, etc.) not to the battery.
 - Never use a booster battery or source of greater voltage, or it could damage engine electrical compounds.
 - Make sure that the jumper cables do not touch moving parts in the engine compartment and that the cable clamps do not contact any other metal.
5. Start the engine of the booster forklift and let it run for a few minutes.

6. Keep the engine speed of the booster forklift at about 2,000 rpm, and start the engine of the forklift being jump started.



CAUTION:

Do not keep the starter motor engaged for more than 10 seconds. If the engine does not start right away, turn the key switch off and wait 3 to 4 seconds before trying again.

7. After starting the engine, carefully disconnect the negative cable and then the positive cable.
8. Replace the vent caps (if so equipped). Be sure to dispose of the cloth used to cover the vent holes as it may be contaminated with corrosive acid.
9. To start the engine with a booster battery, the following instructions and precautions must be followed.



WARNING:

- If done incorrectly, jump starting can lead to a battery explosion, resulting in severe injury or death. It could also damage your forklift. Explosive hydrogen gas is always present in the vicinity of the battery. Keep all sparks and flames away from the battery.

- **Do not allow battery fluid to come into contact with eyes, skin, clothing or painted surfaces. Battery fluid is a corrosive sulfuric acid solution that can cause severe burns. If the fluid comes into contact with anything, immediately flush the contacted area with water.**
- **Keep the battery out of the reach of children.**
- **The booster battery must be rated at 12 volts. Use of an improperly rated battery can damage the forklift.**
- **Whenever working on or near a battery, always wear suitable eye protectors (for example, goggles or industrial safety spectacles) and remove rings, metal bands or any other jewelry. Do not lean over the battery when jump starting.**
- **Do not attempt to jump start a frozen battery. It could explode and cause serious injury.**
- **Your forklift has an automatic engine cooling fan. It could turn on at any time. Keep hands and other objects away from it.**

IN HOT WEATHER

● Oil

Engine oil should be changed to summer type oil (recommended lubricants).

● Coolant

Because the engine is more likely to overheat in hot weather, the forklift should be parked in a shaded area. Overheating sometimes is caused by old, worn or cracked hoses, connections, loosened radiator cap, or old, worn or cracked fan belt. Carefully check the cooling system to maintain the best cooling effect.

● Battery

Because the battery electrolyte evaporates in hot weather, it is necessary to refill the battery with distilled water. (Refer to page 86.)

DAILY CARE AND INSPECTION



WARNING:

Do not open the top panel with the engine running. Do not place hands near the cooling fan because it rotates at a high speed and may cause injury. When opening the hood, be sure to turn off the engine. When starting the engine, check the hood to make sure that it is locked.

To keep your forklift in the proper condition, ready for safe operation, be sure to perform the daily checks indicated below.

If you note any malfunction, notify your supervisor or an authorized UniCarriers FORKLIFT dealer.

Do not operate the forklift if it is in need of repair.

1. Check the engine oil level.
2. Check the engine coolant level, and also check the engine cooling system for leakage.
3. Check the battery fluid level in each cell.
4. Check the amount of brake fluid and check for leakage.
5. Check the steering wheel play.
6. Check the automatic transmission oil level and check for leakage.

7. Check the hydraulic oil level and check for oil line leaks.
8. Check the fuel line (hoses, pipings, connections) for leaks. Also check the fuel tank drain plug for leaks.
9. Check the water separator of the fuel filter. If necessary, drain water from the water separator.
10. Check the tire pressure and check for looseness, wear or damage of wheel nuts and bolts.
 - Remove objects that are embedded in the tread.
 - Check for damage and friction of wheels and for bends and cracks in the rim.
11. Check the operation of the horn, headlamps, all indicators and all warning lights.
12. Check the operation of the hydraulic control valve.
13. Check the mast operation for the following items:
 - Smooth lifting and lowering
 - Smooth roller rotation
 - Wear or damage to chains
 - Lift bracket and forks for bend and damage
14. Check the safety start system operation.

15. Check the brake pedal operation.
16. Check the parking brake operation.
17. Check the backrest and overhead guard for proper installation and function.
18. Check the fork latches.
19. Check the forks for cracks, breaks, bend and wear.
20. Check the radiator core for clogging.
 - If there is dirt or dust on the radiator core, the engine may overheat. Clean the radiator core with compressed air or steam so as not to deform the core fins.
21. Check the color of the exhaust gas after the engine is warmed up.
 - “Colorless or light blue” exhaust represents complete combustion.
 - “Black” exhaust represents incomplete combustion and “White” exhaust shows burning of the engine oil.



WARNING:

- **Exhaust gas contains harmful substances, therefore sufficient ventilation must be secured in case you have to start it in an enclosed area.**
- **This exhaust gas check must be conducted in an open area.**

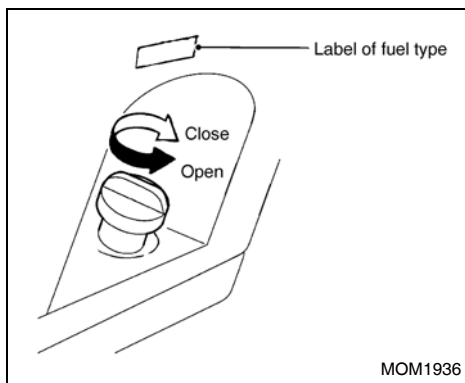

FUEL RECOMMENDATION

WARNING:

- Be sure to stop the engine before refilling with fuel.
- Make sure that there is no fire or flammable objects in the vicinity of the engine. Use only unleaded fuel in the fuel tank of gasoline engine equipped vehicles. Use only diesel fuel in the fuel tank of diesel engine equipped vehicles.

The fuel inlet is located on the body on the left rear side.

When refilling the fuel, check the indication label and do not use the wrong fuel by mistake. Turn the fuel cap counterclockwise to remove it.

If the fuel cap has the optional lock and key, insert the key into the keyhole on the fuel cap and turn the key clockwise for locking or turn it counterclockwise for unlocking.

After refilling, be sure to turn the fuel cap clockwise until it clicks twice or more.

GASOLINE TO BE USED

- Except Germany: Regular (unleaded)
- For Germany: Normal gasoline leaded DIN 51 600 or normal unleaded DIN 51 607.

CAUTION:

- Be careful not to allow water or debris to enter the fuel tank during refilling, as it may cause damage to the ECCS fuel system components.
- Do not use fuel that has been stored for a long time. Such fuel may adversely affect engine performance or shorten its service life, because of possible contaminants in the fuel.

- If the fuel spills out of the fuel inlet, wipe it off and completely clean the area by the inlet.

DIESEL ENGINE FORKLIFT

The diesel engine is designed to run only on diesel fuel with at least a minimum of 42 cetane rating.

For LPG fueling, refer to page 111.

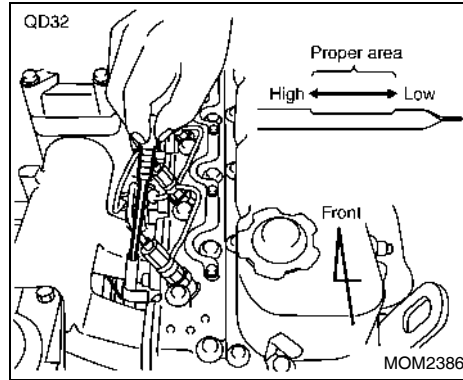
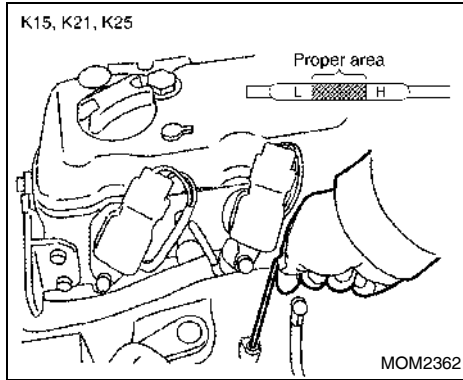

ENGINE OIL LEVEL

To check the oil level, pull out the level gauge, wipe it clean and reinsert; remove it again to read the oil level.

The level should be in the proper area.

After checking the oil level, be sure to return the oil level gauge to the original position.

For QD32 and S4Q2 engines, the level gauge is located on the left side of the engine.

CAUTION:

Do not run the engine when the engine oil level is lower than the minimum indicator (Low) mark, as the engine could be damaged or seize up. If the engine oil level is lower than the minimum indicator (Low) mark, add engine oil through the oil inlet until the oil level reaches the specified amount.

NOTE:

When checking the engine oil, be sure to do it on a level surface before starting the engine and at least 5 minutes after the engine is stopped.

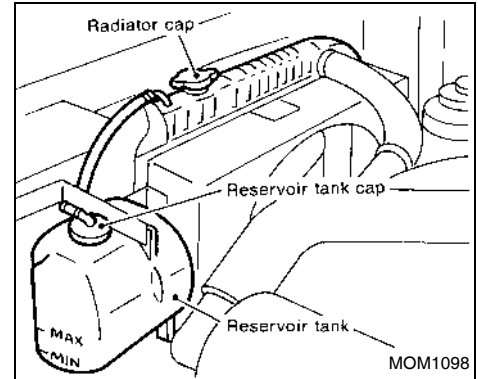
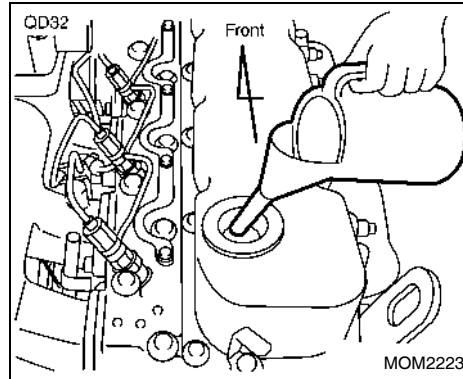
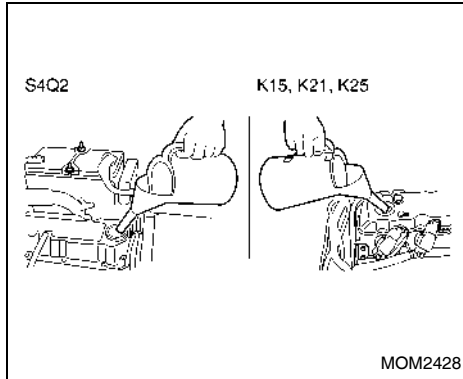

REFILLING ENGINE OIL

1. For refilling the engine oil tank with engine oil, remove the oil filler cap and slowly pour Genuine Motor Oil into the tank while checking the oil level with the oil level gauge until the oil reaches the specified oil level.

CAUTION:

- Carefully pour engine oil into the oil filler so as not to contaminate with dust and foreign substances. If the oil spills, immediately wipe it away.
- Make sure that the oil filler cap is tightened. If the oil filler cap is not properly tightened, engine problems may result.

2. 5 minutes after refilling the engine oil, check if the oil level is between the upper limit (H) and lower limit (L) indicator marks with the oil level gauge.
3. Restore the oil filler cap and oil level gauge to their respective original positions.

ENGINE COOLANT LEVEL

Visually check the amount of coolant in the reservoir tank when the engine is cold. If the coolant level is below the “MIN” level, remove the reservoir tank filler cap and add coolant until the “MAX” level is reached. If the reservoir tank is empty, check the coolant level in the radiator. If there is insufficient coolant in the radiator, pour coolant into the radiator up to the cap and also pour it into the reservoir tank up to the “MAX” level.

If it becomes necessary to repeatedly add coolant, your cooling system should be inspected by an authorized UniCarriers FORK-LIFT dealer.



WARNING:

- Never remove the radiator cap when the engine is hot. Serious burns could be caused by high-pressure fluid escaping from the radiator.
- Wrap a thick cloth around the cap and carefully remove the cap by turning it a quarter turn to allow built-up pressure to escape. When all hissing, steam and liquid stops, slowly turn the cap all the way off.

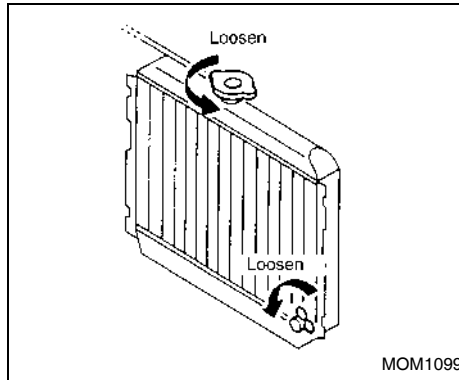

CHANGING ENGINE COOLANT

1. Open the radiator cap and drain cock to drain the coolant. Then flush the cooling system.
2. Close the drain cock securely.
3. Fill the radiator with new coolant up to the filler opening. Fill the reservoir tank up to the "MAX" level. Then put on the radiator cap.
4. Run the engine to the normal operating temperature on dash meter panel.
5. Stop the engine, and after it completely cools down, refill the coolant up to the radiator filler opening. Fill the reservoir tank.

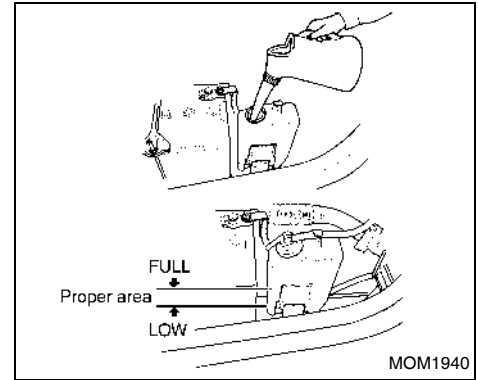

REFILLING ENGINE COOLANT

1. Refill the engine coolant in the reservoir tank.
2. Remove the reservoir tank filler cap.
3. If the reservoir tank is empty, refill the radiator and the reservoir tank with the coolant at the same time. For refilling the coolant in the radiator, remove the radiator cover first and then slowly turn the radiator cap while wrapping it with a cloth to remove it. After removing the radiator cap, fill the radiator with coolant.
4. After refilling the coolant, tighten the reservoir tank filler cap and radiator cap tightly.



WARNING:

To avoid being scalded, do not attempt to change the coolant when the engine is hot.

NOTE:

Refer to page 76 for the proper mixing ratio of antifreeze solution to coolant.



CAUTION:

- The long-life coolant can degrade the coated surface. If it adheres to the coated surface, wash the coolant away with water.
- Be sure to use the long-life coolant specified by UniCarriers Corporation. The cooling performance and anticorrosive treatment cannot be assured if another coolant is used.
- Do not refill the coolant above the “FULL” level of the reservoir tank. If it exceeds the “FULL” level, it may spill out as the engine is warmed up. Carefully refill the coolant so as not to contaminate it with foreign substances.

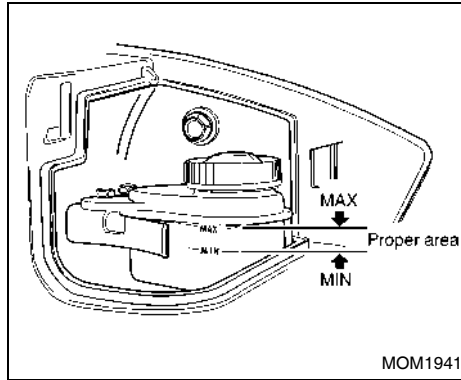

BRAKE FLUID LEVEL CLUTCH FLUID LEVEL (MT vehicle)

NOTE:

The brake fluid reservoir tank also serves as the clutch fluid reservoir tank.

Check if the brake fluid level in the brake fluid reservoir tank inside the lid on the left side of the instrument panel is within the proper range. If the level is lower than the “MIN” level, refill the reservoir tank with the brake fluid (Genuine Brake Fluid). At the same time, examine the outside and periphery of the reservoir tank for brake fluid leak or stain by visual check.



WARNING:

- Use DOT3 (F.M.V.S.S. No. 116) brake fluid only.
- If brake fluid leak or stain is detected, immediately report it to the administrator of the forklift for taking proper measures or contact an authorized UniCarriers FORKLIFT dealer to inspect and repair it. Anyway, do not operate the forklift until it is completely repaired.
- If a brake fluid other than those specified by UniCarriers Corporation or an aged brake fluid is used, it may cause deterioration in the performance and accident. Be sure not to use such the brake fluid.
- Be careful not to adhere the brake fluid to the coated surface, because the brake fluid vitiates the coated surface.
- When refilling the brake fluid reservoir tank with the brake fluid, be careful not to mix dust and foreign substances in the fluid.
- If the brake fluid is extraordinarily consumed, immediately report it to the forklift administrator for taking proper measures or contact an authorized UniCarriers FORKLIFT dealer to inspect it.

REFILLING BRAKE FLUID REFILLING CLUTCH FLUID (MT vehicle)

Turn the brake reservoir tank cap counter-clockwise to remove it, and gently pour the brake fluid (Genuine Brake Fluid) into the tank until the fluid level reaches the “MAX” level.



WARNING:

- When refilling the brake fluid reservoir tank with the brake fluid, be careful not to mix dust and foreign substances in the fluid.
- If a brake fluid other than those specified by UniCarriers Corporation or an aged brake fluid is used, it may cause deterioration in the performance and accident. Be sure not to use such the brake fluid.
- Be careful not to adhere the brake fluid to the coated surface, because the brake fluid vitiates the coated surface. If the brake fluid adheres to the coated surface, immediately wipe it out so that no liquid remains on the coated surface.
- If the brake fluid is extraordinarily consumed, immediately report it to the forklift administrator for taking proper measures or contact an authorized UniCarriers FORKLIFT dealer to inspect it.

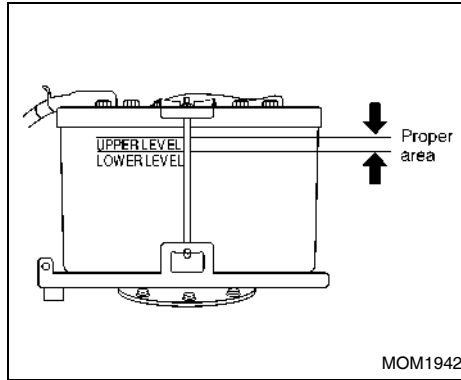

BATTERY FLUID LEVEL

Open the top panel, and then check the fluid level in each battery cell.

REFILLING BATTERY FLUID

If the electrolyte (battery fluid) is insufficient, remove the caps from the battery and carefully refill the respective battery cells with distilled water only until the fluid level reaches the “UPPER LEVEL” so as not to contaminate the fluid with dust and foreign substances.

At the same time, visually inspect the battery body for cracks or damage. If there is any damage, immediately replace the battery with a new one.

After refilling the battery with distilled water, tighten the respective caps tightly. If the battery fluid spills out, wash it away with water and wipe down the wet surface.



WARNING:

- Since the battery produces explosive hydrogen gas, handle it in a location where there are no sources of ignition or open flame.
- Do not allow a person who does not have knowledge of the battery and its handling manner inspect or maintain the battery.
- Because the battery fluid contains sulfuric acid, be sure to wear proper protective clothing (goggles, rubber gloves, etc.). Be careful not to get the fluid in eyes, on the skin or clothes, otherwise it may cause blindness, burns or damage to the clothes. If the battery fluid contacts part of the body, immediately wash it away with a large amount of cool water. If the fluid gets into eyes, immediately flush the eyes and consult a doctor as soon as possible. If the fluid is swallowed by mistake, immediately gargle repeatedly with a large amount of cool water, drink much water and consult a doctor as soon as possible.
- If battery fluid flows or leaks out of the battery, immediately neutralize it with an acid neutralizer (sodium bicarbonate, slaked lime, sodium carbonate, etc.) and then thoroughly wash it away with water, because it may cause corrosion of the floor or parts.

- Do not put anything metal, such as a tool on the battery. If metal contacts the terminal, it may cause not only a short circuit but a burn or explosion because the hydrogen gas produced by the battery may catch fire from the spark generated by the short circuit.
- Check the battery fluid level once a week to prevent the battery from running short of the electrolyte. If the battery is used with insufficient battery fluid, the battery may explode. When refilling the battery with the battery fluid, do not pour the fluid above the “UPPER LEVEL”.
- If the battery is used when the battery fluid level is below the “LOWER LEVEL”, it may shorten the service life of the battery and may cause explosion of the battery because insufficient battery fluid promotes deterioration in internal parts of the battery.
- Be careful not to wipe down the top of the battery with a dry cloth, not to cover the battery with a vinyl sheet or not to dust the battery, because this may generate static electricity and potentially cause the battery to explode.
- Do not touch the battery with a charged body, otherwise it may cause an explosion of the battery because of ignition from static electricity.



CAUTION:

The time and date will be reset if the battery cable is disconnected (for example, when the battery is replaced). Set the time and date again.

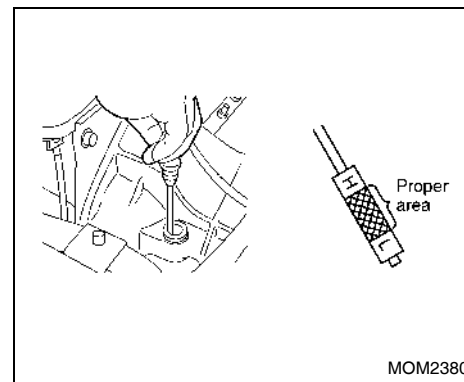

MOM2380

AUTOMATIC TRANSMISSION FLUID LEVEL

1. Stop the engine after idling for about 10 minutes.
2. Open the top panel and check if there is leakage of the automatic transmission fluid. Then, pull out the level gauge and wipe down the tip of the gauge with a clean cloth.
3. Insert the level gauge to the limit and gently pull it out again.
4. Make sure that the fluid adhered to the tip of the level gauge is not extremely worn, discolored or contaminated by foreign substances, and also check if the fluid level is within the proper range.

5. If the fluid is insufficient, refill the automatic transmission with the specified fluid so that the level gauge reads the proper range.



CAUTION:

- Do not operate the forklift with insufficient automatic transmission fluid, because the forklift may be disabled from running.
- If the transmission fluid is extremely worn, discolored or contains foreign substances, immediately report it to your supervisor or contact an authorized UniCarriers FORKLIFT dealer to inspect it.

REFILLING AUTOMATIC TRANSMISSION FLUID

Automatic transmission fluid can be added through the level gauge hole. Checking the fluid level with the level gauge, pour the Genuine Matic Fluid (refer to page 96) into the level gauge hole until the fluid level is in the proper range.



CAUTION:

- Do not use any automatic transmission fluid other than those specified by UniCarriers Corporation. Otherwise, it may cause a malfunction in the torque converter. Be sure to refill the automatic transmission with the specified quantity of the Genuine Matic Fluid (refer to page 96).
- Be careful not to mix dust or foreign substance in the transmission fluid during refilling.

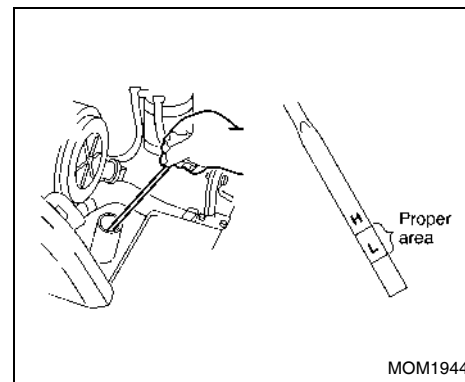

HYDRAULIC OIL

Check the oil level in the hydraulic oil tank.

1. After visually checking for oil leakage, turn the hydraulic oil filler cap located on the right side of the operator's seat to remove it.
2. Wipe down the level gauge attached to the cap with a clean cloth. Insert the clean level gauge into the hydraulic oil filter (do not screw the level gauge in) and pull it out again.
3. If the oil level that can be checked on the level gauge is between the two indicator lines marked on the level gauge, the quantity of the hydraulic oil is normal.

NOTE:

For correctly checking the hydraulic oil level, park the forklift on level ground and stand the mast vertically with the fork lowered to the limit (contacting ground).

REFILLING HYDRAULIC OIL

Remove the hydraulic oil filler cap. While checking the hydraulic oil level with the level gauge, pour the specified hydraulic oil (Genuine Hydraulic Oil) into the oil filler until the oil level is in the proper area.



CAUTION:

- Do not use any hydraulic oil other than those specified by UniCarriers Corporation as it may cause not only deterioration in the performance of the forklift but could result in an accident.
- Carefully add the hydraulic oil so as not to mix dust and foreign substances in the oil.

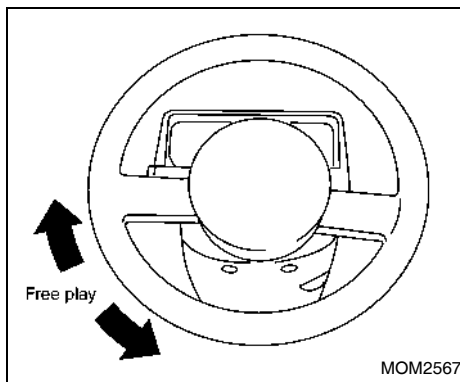

STEERING WHEEL

Turn the steering wheel to the right and left. A play in the circumference of less than 30 mm (1.18 in) at idling is normal.

If there is excessive play or looseness, have the steering wheel adjusted by an authorized UniCarriers FORKLIFT dealer.

WHEEL AND TIRE

Maintain the correct tire pressures by checking frequently with an accurate tire gauge.
Inflate tires to the correct pressure if necessary.

1F1 series

kgf/cm² (kPa, bar, psi)

Vehicle		Front tire	Tire pressure	
1.6 ton compact vehicle	Single tire	6.00-9-12PR	10.0 (981, 9.81, 142)	
1.5 ton	Single tire	6.50-10-10PR(I)	7.0 (686, 6.86, 100)	
	Double tire	Standard	4.50-12-8PR(I)	7.0 (686, 6.86, 100)
		Special	6.50-10-10PR(I)	7.0 (686, 6.86, 100)
1.75 ton	Single tire	6.50-10-10PR(I)	7.0 (686, 6.86, 100)	
	Double tire	Standard	4.50-12-8PR(I)	7.0 (686, 6.86, 100)
		Special	6.50-10-10PR(I)	7.0 (686, 6.86, 100)
Vehicle		Rear tire	Tire pressure	
1.6 ton compact vehicle		5.00-8-8PR	7.0 (686, 6.86, 100)	
1.5 ton		5.00-8-8PR(I)	7.0 (686, 6.86, 100)	
1.75 ton		5.00-8-10PR(I)	9.0 (883, 8.83, 128)	

1F2 series

kgf/cm² (kPa, bar, psi)

Vehicle		Front tire	Tire pressure	
2.5 ton compact vehicle	Single tire	21×8-9-14PR	9.0 (883, 8.83, 128)	
2.0 ton, 2.5 ton	Single tire	7.00-12-12PR(I)	7.0 (686, 6.86, 100)	
	Double tire	Standard	5.50-15-8PR(I)	7.0 (686, 6.86, 100)
		Special	7.00-12-12PR(I)	7.0 (686, 6.86, 100)
3.0 ton	Single tire	28×9-15-12PR(I)	7.0 (686, 6.86, 100)	
	Double tire	Standard	6.00-15-10PR(I)	7.0 (686, 6.86, 100)
		Special	28×8-15-12PR(I)	7.0 (686, 6.86, 100)
3.5 ton	Single tire	250-15-16PR(I)	7.0 (686, 6.86, 100)	
	Double tire	Standard	6.00-15-10PR(I)	7.0 (686, 6.86, 100)
		Special	28×9-15-12PR(I)	7.0 (686, 6.86, 100)
Vehicle		Rear tire	Tire pressure	
2.5 ton compact vehicle		18×7-8-14PR	9.0 (883, 8.83, 128)	
2.0 ton, 2.5 ton		6.00-9-10PR(I)	8.5 (834, 8.34, 121)	
3.0 ton		6.50-10-10PR(I)	7.0 (686, 6.86, 100)	
3.5 ton		6.50-10-12PR(I)	9.0 (883, 8.83, 128)	



WARNING:

- If the tire pressure is not correct, problems such as tires bursting or premature tire wear will result.
- When checking the tire pressure, do not face the tire side to avoid a danger because the tire pressure is very high.

NOTE:

There is the pneumatic type cushion tire without inner tube (so-called tubeless tire or non-puncture tire) supplied. Such the tire has no need of tire pressure check.

MAINTENANCE

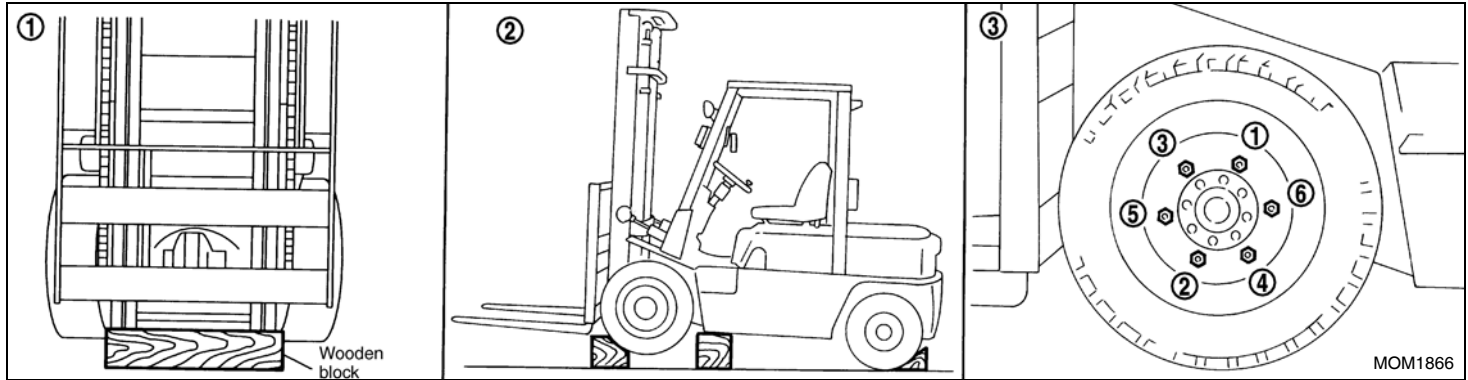

TIRE REPLACEMENT



WARNING:

- Do not get under or ride on the forklift when it is jacked up. Doing so could result in serious injury or death.
- Use a jack with a capacity of 3.0 tons or more.



CAUTION:

- Always park the forklift on a flat, level and solid surface.
- Unload cargo from the forklift.
- Do not start or stop the engine or operate control levers from any position other than the operator's seat.
- Keep the parking brake lever fully applied.
- Make sure that the selector lever is in the neutral position.

NOTE:

There are two types of wheel nut wrenches: a large one for the front wheels and a small one for the rear wheels.

Front tire

1. Place the forklift on a level and solid surface.
2. Start the engine and raise the carriage about 250 mm (9.84 in).
3. Place chocks behind the rear wheels to prevent movement of the forklift.
4. Loosen the wheel nuts one or two turns each by turning them counterclockwise.
5. Tilt the mast fully backward and place a wooden block under each side of the outer mast.

**CAUTION:**

- Use hardwood or plastic blocks that do not slip easily and are strong enough to withstand the forklift weight. Do not use broken or cracked blocks or metal blocks that slip easily.
 - Use wooden blocks of the following size. Height: Allows the block to tightly fit between the backward tilted mast and the road surface.
 - Width: 50 to 100 mm (1.97 to 3.94 in) larger than the longitudinal length of the mast rail.
 - Length: 20 to 40 mm (0.79 to 1.57 in) larger than the width of the outside mast.
 - To prevent the forklift from inclining, do not place wooden blocks of different heights under the right and left masts.
6. Tilt the mast forward until the front tires are raised from the surface.

**WARNING:**

- Do not operate the control lever quickly. Doing so may cause the mast on wooden blocks on the ground to become unstable.
 - Stop jacking up the forklift when the tires are clear of the ground. Jacking up the forklift excessively high could cause it to tip over.
 - If the front wheels are lifted for a long time by means of the mast, the mast may incline backward by itself. To prevent this, be sure to insert a wooden block that goes from side to side of the frame.
 - Do not remove wheel nuts until the front tires are raised from the ground.
7. Support the forklift by putting additional wooden blocks under each side of the front-end frame as shown on page 91. Stop the engine.
8. Remove the wheel nuts and replace the front tire.

**WARNING:**

- When removing the tire from the wheel rim, do not remove rim set bolts and nuts before releasing air.
 - Never get under the forklift while it is supported only by the wooden blocks.
9. Reinstall the wheel nuts and temporarily tighten them in the sequence shown on page 91.

**CAUTION:**

Each wheel nut has a conical bearing surface and each hole in the rim is countersunk so that they can fit with each other. After attaching all wheel nuts, make sure that each nut tightly fits with the countersunk hole. If wheel nuts are attached in the wrong direction, they may loosen easily and may cause bolts to break and the wheel to come off.

10. Start the engine and remove the wooden blocks from the underside of the frame.
11. Lower the forklift slowly by tilting the mast fully backward. Remove the wooden block from under the mast, and remove the chocks.

12. Tighten the wheel nuts to the specified torque in a crisscross fashion. Refer to the "Tightening torque" table on page 95.
13. Adjust the tire pressures to the value specified in the "Tire pressure" table on page 90.
14. After replacing a tire, drive the forklift a short distance and check the tightening torque of each wheel nut again.

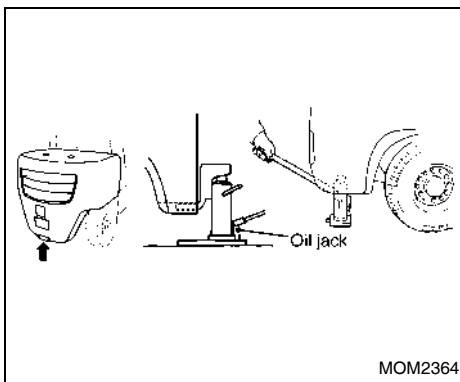

Rear tire

NOTE:

To replace a tire, contact an authorized UniCarriers FORKLIFT dealer.

1. Place the forklift on a level and solid surface.
2. Apply the parking brake, and place chocks behind the front tires to prevent movement of the forklift.
3. Place the jack under the cutout portion at the bottom of the counterweight, as shown in the above illustration.

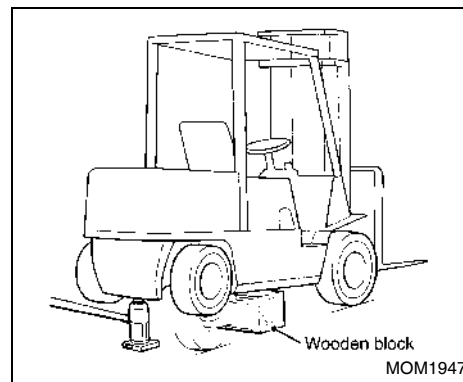

WARNING:

- Never get under or ride on the forklift when it is jacked up. Doing so could result in serious injury or death.
 - Use a jack with a capacity of 3.0 tons or more.
4. Loosen the wheel nuts one or two turns each by turning them counterclockwise.

WARNING:

- Do not remove wheel nuts until the rear tires are raised from the ground.**
5. Jack up the forklift slowly until the rear tires clear the ground, and support the forklift by putting wooden blocks under each side of the rear end frame as shown in the illustration.

! WARNING:

- Stop jacking up the forklift when the tires are slightly raised from the ground. Jacking up the forklift excessively high could cause it to tip over.
- Use hardwood or plastic blocks that do not slip easily and are strong enough to withstand the forklift weight.

Do not use broken or cracked blocks or metal blocks that slip easily.

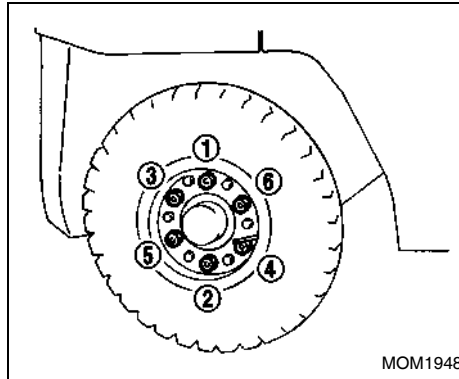

6. Remove the wheel nuts and replace the rear tire.

! WARNING:

- When removing the tire from the wheel rim, do not remove rim set bolts and nuts before releasing air.
 - Never get under the forklift while it is supported only by the wooden blocks.
7. Reinstall the wheel nuts and temporarily tighten them in the sequence shown in the above illustration.
 8. Remove the wooden blocks and lower the forklift slowly until the rear wheel touches the ground. Then remove the chocks and the jack.

9. Tighten the wheel nuts to the specified torque in a crisscross fashion. Refer to the "Tightening torque" table on page 95.
10. Adjust the tire pressure to the value specified in the "Tire pressure" table on page 90.
11. After replacing a tire, drive the forklift a short distance and check the tightening torque of each wheel nut again.

Tightening torque

Unit: N·m (kg·m, ft·lb)

Model			1F1 series		1F2 series				
			1.6 ton compact vehicle	1.5 ton, 1.75 ton	2.5 ton compact vehicle	2.0 ton, 2.5 ton	3.0 ton	3.5 ton	
Pneumatic tire model	Front	Single tire	167 to 226 (17 to 23, 123 to 166)	167 to 226 (17 to 23, 123 to 166)	196 to 245 (20 to 25, 145 to 180)	245 to 294 (25 to 30, 181 to 217)	441 to 588 (45 to 60, 325 to 434)	441 to 588 (45 to 60, 325 to 434)	
			Double tire	Standard	—	167 to 226 (17 to 23, 123 to 166)*4	—	Ⓑ539 to 686 (55 to 70, 398 to 506)*1	Ⓔ539 to 686 (55 to 70, 398 to 506)*1
		—			167 to 226 (17 to 23, 123 to 166)*5	—	588 to 735 (60 to 75, 434 to 542)*2	588 to 735 (60 to 75, 434 to 542)*2	588 to 735 (60 to 75, 434 to 542)*2
		Special		—	Ⓑ167 to 226 (17 to 23, 123 to 166)*1	—	Ⓑ539 to 686 (55 to 70, 398 to 506)*1	Ⓔ539 to 686 (55 to 70, 398 to 506)*1	Ⓔ539 to 686 (55 to 70, 398 to 506)*1
				—	78.4 to 98 (8 to 10, 58 to 72)*3	—	588 to 735 (60 to 75, 434 to 542)*2	588 to 735 (60 to 75, 434 to 542)*2	588 to 735 (60 to 75, 434 to 542)*2
			—	167 to 226 (17 to 23, 123 to 166)*2	—	—	—	—	
	Rear		167 to 226 (17 to 23, 123 to 166)	167 to 226 (17 to 23, 123 to 166)	135 to 155 (14 to 15, 100 to 114)	167 to 226 (17 to 23, 123 to 166)	167 to 226 (17 to 23, 123 to 166)	210 to 256.7 (21 to 26, 155 to 189)	

Ⓑ: Bolt

Ⓔ: Nut

*1: Inner wheel

*2: Outer wheel nut

*3: Hub nut (outer hub)

*4: Wheel nut

*5: Wheel composite nut

DRAIN PLUG

Remove the drain plug before washing the inside of the fuel tank. To do this, turn the drain plug counterclockwise.

- When removing the drain plug, be careful not to lose the packing. Before installing the drain plug, be sure to install the packing.

Tightening torque:

25 to 39 N·m (2.6 to 3.9 kgf·m, 18 to 28 ft·lb)

RECOMMENDED LUBRICANTS

Item		Specifications	Remarks
Engine oil	Gasoline	API SJ or SL	Refer to RECOMMENDED SAE VISCOSITY NUMBER.
	Diesel	API CD	
Gear oil	Transmission	API GL-4 or 5	
	Differential	API GL-4 or 5	
Grease	Chassis	N.L.G.I. 1	Lithium soap base
	Wheel bearing	N.L.G.I. 2	
	Mast and chain guide bar	N.L.G.I. 2	
Power steering oil		Hydraulic oil I.S.O. VG32	—
Hydraulic oil		Hydraulic oil I.S.O. VG32	Wear-proof oil
Automatic transmission fluid		Type DEXTRON or M2C-33E or F	—
Brake fluid		DOT3 (F.M.V.S.S. No. 116)	F.M.V.S.S.: Federal Vehicle Safety Standard
Antifreeze		—	Permanent antifreeze (Ethylene glycol base)

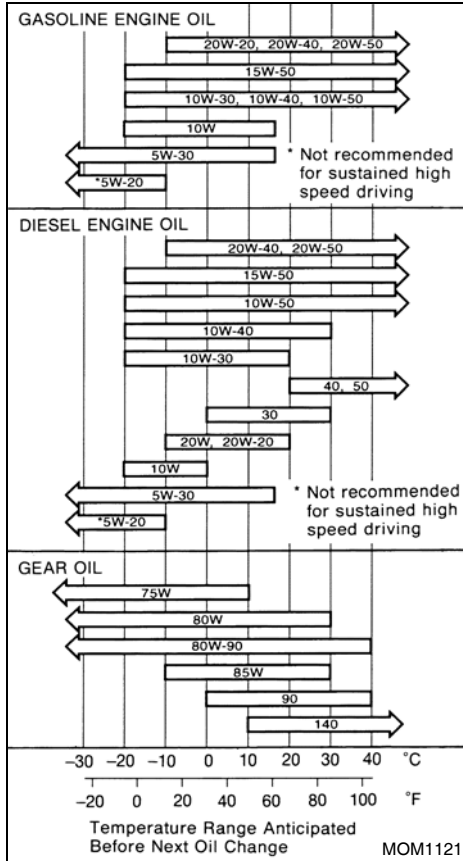

RECOMMENDED SAE VISCOSITY NUMBER

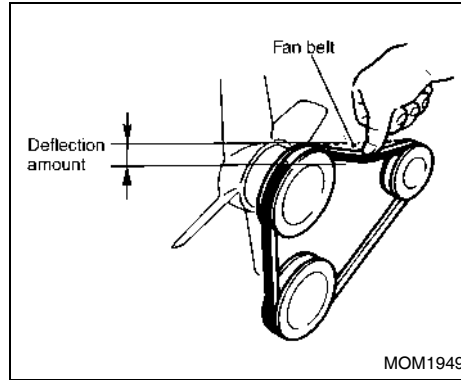

ENGINE

Fan belt

Check the belt deflection by applying moderate thumb pressure at a point midway between the pulleys. If necessary, adjust the belt deflection.

Fan belt deflection:

K15, K21, K25
11 to 13 mm (0.43 to 0.51 in)

QD32
11 to 13 mm (0.43 to 0.51 in)

S4Q2
Approx. 13 mm (Approx. 0.51 in)



WARNING:

- Be sure that the engine is not running and the parking brake is applied securely.
- Keep hands clean.

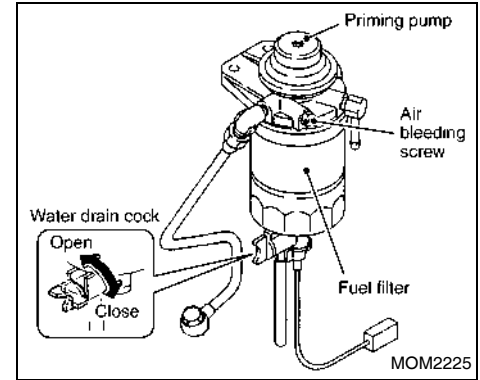

FUEL FILTER

Draining water from water separator (diesel engine forklift)

If the fuel filter warning lamp illuminates while the engine is running, drain any water that is in the fuel filter. Proceed as follows:

1. Open the top panel. Refer to "Top panel" on page 71.
2. Place a container under the fuel filter.
3. Put the saucer under the water drain cock, and then loosen the water drain cock 4 to 5 turns to drain the water.
4. After the water has been completely drained, tighten the drain cock.

⚠ WARNING:

- Never allow open flames, smoking or other sources of ignition in the area of fuel filter.
- Every part remains very hot immediately after the engine has stopped. Wear protective gloves and perform the operation carefully so as not to touch heated parts around the water drain cock.

⚠ CAUTION:

- Fuel may also spout out along with water drained. If fuel splashes over parts, wipe it off completely.
- If operation is continued for a long time while the sediment chamber (fuel filter) level warning lamp is lit, the fuel injection pump might seize up.

Air purge (diesel engine forklift)

NOTE:

Air purge operation for diesel engine vehicle is unnecessary.

When refilling an empty fuel tank and/or draining water from the water separator, purge the air out of the fuel system. Proceed as follows:

1. Loosen the air purge screw at the upper part of the fuel filter.

2. Move the priming pump up and down until no further air-bleed comes out of the air purge screw.

3. Tighten the air purge screw.

⚠ WARNING:

Do not smoke or hold a flame near the operation area.

⚠ CAUTION:

- Do not remove the screw completely, otherwise a large amount of fuel may spout out.
- Fuel may spout out from the air purge screw hole during air purge. Be sure to block the hole with a cotton cloth or a similar item to prevent fuel from splashing over surrounding parts.
- If fuel spills during replenishment, be sure to wipe it off.

NOTE:

After draining water from the fuel filter, perform air purge operation.

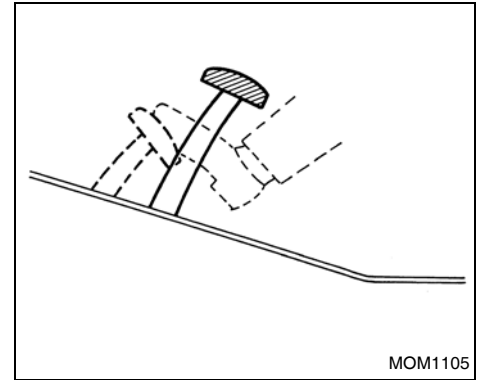

CHASSIS AND BODY

Brake pedal

When the engine is running and the brake pedal is fully depressed, the distance between the upper surface of the pedal pad and floorboard should be 60 mm (2.36 in) or more.

When this distance approaches the prescribed limit value, have the brake adjusted by an authorized UniCarriers FORKLIFT dealer.

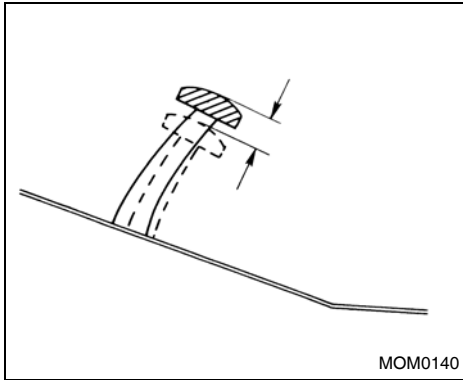

Pedal free play

The standard free play of the pedals is as follows:

Unit: mm (in)

Model	All models
Brake pedal	1 to 3 (0.04 to 0.12)
Clutch pedal (MT model)	2 to 5 (0.08 to 0.20)

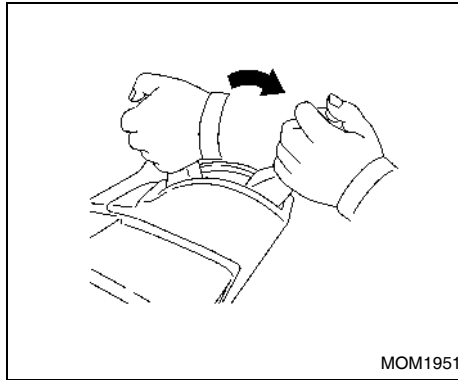

Parking brake lever

Make sure that the parking brake works properly when pulled and then returns to its original (release) position.

Pulling force at gripping position:

176 to 226 N (18 to 23 kg, 39 to 50 lb)

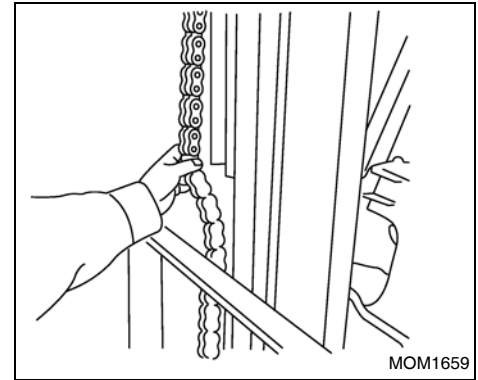

Lift chain

Check lift chain tension periodically. Set the fork level at position of 20 to 30 mm (0.79 to 1.18 in) from the ground and depress the mid-point of the lift chain with the finger.

Deflection:

25 to 35 mm (0.98 to 1.38 in)

If the deflection is not within the specifications, have the chain adjusted by an authorized UniCarriers FORKLIFT dealer or other competent service shop.



WARNING:

Never put your foot under the fork during checking.

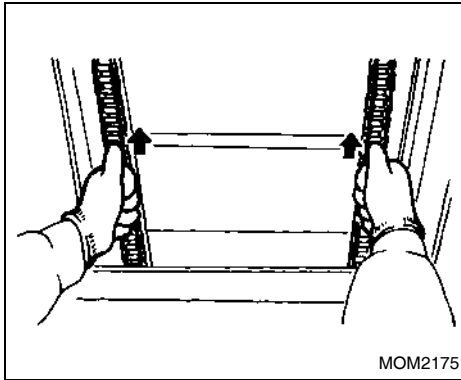

Lift chain (3.5 t model)

Check the lift chain tension periodically. Set the fork level at a position of 20 to 30 mm (0.79 to 1.18 in) from the ground and push the mid-point of the lift chain with a finger.

Deflection:

25 to 35 mm (0.98 to 1.38 in)

If there is a difference between the right and left chain deflection, or if the deflection is not within the specified range, have the chain adjusted by an authorized UniCarriers FORK-LIFT dealer.



WARNING:

Never put your foot under the fork during checking.

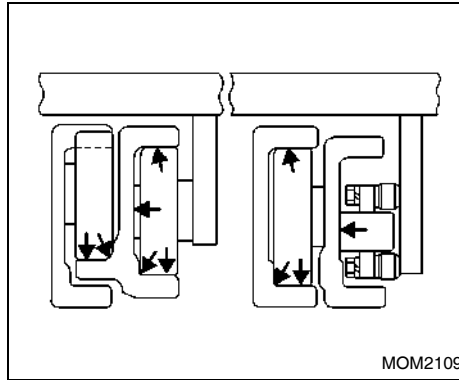

Lubrication points

Lubricate the following points periodically in accordance with the Periodic Maintenance and Lubrication Schedule chart.

Mast

Apply a coat of grease to the thrust metals and liner.

NOTE:

- **The lubrication interval will vary with working conditions. During months in which working conditions are severe, it will be necessary to grease the parts frequently.**

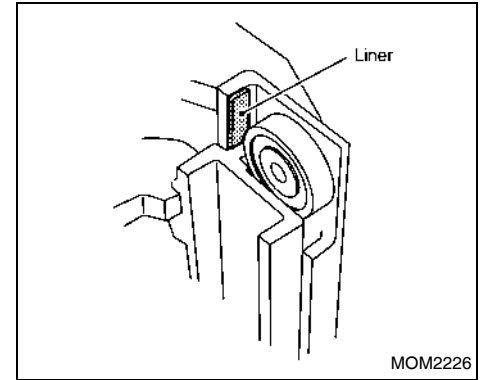

- **When forklift is operated, apply a coat of grease to the contact surface of the lift roller and inner mast or outer mast.**

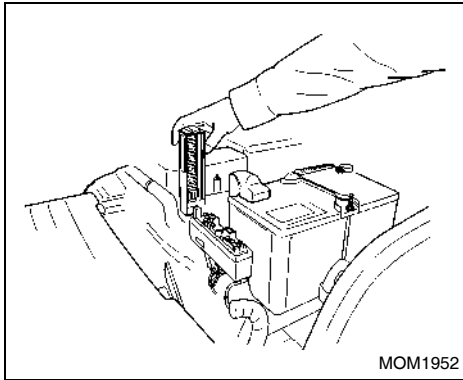

Fuses

The fuse box is installed in front of the battery under the top panel. Remove the fuse box cover and visually check if the fuse is blown. If the fuse is burned out, replace it.

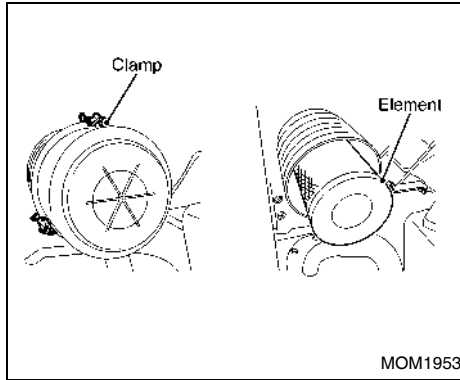

Air cleaner

1. Remove the three clamps securing the air cleaner case and take the element out carefully.
2. Clean the element by tapping it by hand or blow compressed air to it from the inside.
3. After cleaning, visually check the element and replace it if it is still dirty.



CAUTION:

When cleaning the air cleaner element, always wear a dust mask and dustproof glasses. OSHA requires that air nozzles be used to reduce pressure to no more than 206 kPa (2.06 bar, 2.1 kgf/cm², 30 psi).

NOTE:

For cleaning, use compressed air with a pressure of 686 kPa (6.86 bar, 7 kgf/cm², 100 psi) or less.

PERIODIC MAINTENANCE AND LUBRICATION SCHEDULE FOR EMISSION CONTROL SYSTEM MAINTENANCE

Engine Model: K15, K21, K25

Before delivery of your new forklift, your dealer provides a pre-delivery inspection and adjustment service specified by the factory and designed to ensure satisfactory performance. The following tables list the servicing required to keep your forklift operating at peak mechanical condition, and should be attended to as indicated below, preferably by an authorized dealer.

MAINTENANCE OPERATION		MAINTENANCE INTERVAL													
Periodic maintenance should be performed after specified intervals have elapsed in months or hours, whichever comes first.	Months	1	2	3	4	5	6	7	8	9	10	11	12	18
	Hundreds of hours	2	4	6	8	10	12	14	16	18	20	22	24	36
ENGINE COMPARTMENT MAINTENANCE (EXCEPT LPG FUEL SYSTEM)															
1. Intake & exhaust valve clearance (operating temp.)		A		A			A			A			A	A
2. Drive belt tension		I	I	I	I	I	I	I	I	I	I	I	I	I
3. Engine oil	(1)	R	R			R			R			R	(2)	(2)
4. Oil filter	(1)	R	R			R			R			R	(2)	(2)
5. Engine coolant (L.L.C.)													R	
6. Air cleaner element	(1)	C	C	C	C	C	R	C	C	C	C	C	R	R
7. Spark plugs	(1)	I	I	I	I	I	I	I	I	I	I	I	I	R
8. PCV valve	(1)			I			I			I			I	I

NOTE: (1) More frequent maintenance is necessary under dusty or other dirty operating conditions.

(2) Replacement [Every 500 hours (3 months)] of engine oil and oil filter.

Abbreviations: I = Inspect. Correct or replace if necessary. R = Replace A = Adjust C = Clean D = Drain

All items listed above must be maintained in order to meet and keep emission control systems operating at design levels. Failure to maintain the systems could compromise the warranty.

For reference: Normal operating conditions and time is based on a clean and dry environment and 1,200 hours or less in one year.

PERIODIC MAINTENANCE AND LUBRICATION SCHEDULE

Engine Model: S4Q2, QD32

Before delivery of your new forklift, your dealer provides a pre-delivery inspection and adjustment service specified by the factory and designed to ensure satisfactory performance.

The following tables list the servicing required to keep your forklift operating at peak mechanical condition, and should be attended to as indicated below, preferably by an authorized dealer.

MAINTENANCE OPERATION		MAINTENANCE INTERVAL													
Periodic maintenance should be performed after specified intervals have elapsed in months or hours, whichever comes first.	Months	1	2	3	4	5	6	7	8	9	10	11	12	18
	Hundreds of hours	2	4	6	8	10	12	14	16	18	20	22	24	36
ENGINE COMPARTMENT MAINTENANCE															
1. Intake & exhaust valve clearance		A		A			A			A			A	A
2. Drive belt tension		I	I	I	I	I	I	I	I	I	I	I	I	I
3. Engine oil	(1)			R		R			R			R		
4. Oil filter	(1)			R		R			R			R		
5. Engine coolant (L.L.C.)													R	
6. Water separator		D		D			D			D			R	D
7. Air cleaner element	(1)	C	C	C	C	C	R	C	C	C	C	C	R	R
8. Engine idle rpm		A	A	A	A	A	A	A	A	A	A	A	A	A
9. Nozzle	(2)						I						I	I

NOTE: (1) More frequent maintenance is necessary under dusty or other dirty operating conditions.

(2) If engine power decreases, black exhaust smoke is emitted or engine noise increases before the maintenance period comes, check and, if necessary, adjust the fuel injection nozzle starting pressure and the fuel spray pattern.

Abbreviations: I = Inspect. Correct or replace if necessary. L = Lubricate R = Replace A = Adjust C = Clean D = Drain T = Retighten

MAINTENANCE OPERATION

Periodic maintenance should be performed after specified intervals have elapsed in months or hours, whichever comes first.

		MAINTENANCE INTERVAL													
Months	1	2	3	4	5	6	7	8	9	10	11	12	18	
Hundreds of hours	2	4	6	8	10	12	14	16	18	20	22	24	36	

ENGINE COMPARTMENT MAINTENANCE (LPG FUEL SYSTEM)

1. Piping or pipe connector portion for gas leakage	I	I	I	I	I	I	I	I	I	I	I	I	I	I		
2. Tar in vaporizer	D	D	D	D	D	D	D	D	D	D	D	D	D	D		
3. Piping or pipe connector portion for damage	I	I	I	I	I	I	I	I	I	I	I	I	I	I		
4. Mounting bracket of LPG cylinder for looseness or damage	I	I	I	I	I	I	I	I	I	I	I	I	I	I		
5. Piping or pipe connector portion for gas leakage 1)																	
6. Filter for LPG						C			C			C			R	C

NOTE: (1) More frequent maintenance is necessary under dusty or other dirty operating conditions.

Abbreviations: I = Inspect. Correct or replace if necessary. R = Replace A = Adjust C = Clean D = Drain

For reference: Normal operating conditions and time is based on a clean and dry environment and 1,200 hours or less in one year.

MAINTENANCE SCHEDULE

CHASSIS AND BODY MAINTENANCE

- The inspection/service items listed below are described in this chapter.
- The symbols in the timing column have the following meanings:
 - : Inspection/service in accordance with the occupational safety and health regulations
 - : Inspection/service recommended by UniCarriers Corporation
- The inspection/service timings shown below are based on the assumption that the forklift is operated for 200 hours in a month. When determining the inspection/service timing, take into account the actual working conditions of the forklift.

Inspection/service item	Working hours	Timing	
		Self-imposed inspection	
		Monthly	Annual
1. Inspection of battery fluid level		○	●
2. Inspection of specific gravity of battery fluid		○	○
3. Inspection of automatic transmission fluid level		○	●
		6 months (every 1200 working hours)	
4. Inspection of A/T line pressure		If necessary	
5. Inspection of stall speed		If necessary	
6. Inspection of differential gear oil level (including inspection of manual transmission oil level)			●
7. Replacement of differential gear oil		12 months (every 2400 working hours)	
8. Application of wheel bearing grease		12 months (every 2400 working hours)	
9. Inspection of wheel bearing for looseness (inspection/adjustment of preload)		●	●
10. Adjustment of steering axle		If necessary	
11. Inspection of tire air pressure		●	●
12. Inspection of tire for wear		●	●
13. Inspection of wheel nut		●	●
14. Inspection of brake fluid level		●	●
15. Replacement of brake fluid		12 months (every 2400 working hours)	
16. Inspection/adjustment of brake pedal		●	●

Inspection/service item	Working hours	Timing	
		Self-imposed inspection	
		Monthly	Annual
		200	2400
17. Inspection/adjustment of inching brake pedal		○	●
18. Inspection of brake lining for wear			●
19. Adjustment of shoe clearance			●
20. Inspection/adjustment of hand brake operation effort			●
21. Inspection of steering wheel for play and looseness		●	●
22. Inspection of steering wheel operation effort		●	●
23. Inspection of steering system fluid pressure		If necessary	
24. Inspection of hydraulic fluid level		●	●
25. Replacement of hydraulic fluid		12 months (every 2400 working hours)	
26. Replacement of micron filter		6 months (every 1200 working hours)	
27. Cleaning of suction filter		12 months (every 2400 working hours)	
28. Inspection of hydraulic pressure		If necessary	
29. Inspection of fork		●	●
30. Inspection of carriage height		If necessary	
31. Inspection/adjustment of lift chain tension		●	●
32. Inspection of carriage roller		If necessary	
33. Inspection/adjustment of mast roller		If necessary	
34. Adjustment of mast roller clearance		If necessary	
35. Inspection of mast operation		●	●
36. Inspection of cylinder operation		●	●
37. Inspection of cylinder		●	●
38. Applying grease		Refer to the lubrication schedule chart.	
39. Inspection/replacement of fuses		If necessary	
40. Bulb replacement		If necessary	

LUBRICATION CHART

Item	Suitable oil	
	Below 16°C (60°F)	Above 16°C (60°F)
① Gasoline engine oil	Refer to page 96	
② Diesel engine oil		
③ Gear oil	SAE No. 90	SAE No. 140
④ W.B. grease	NLGI No. 2	
⑤ Chassis grease	NLGI No. 1	
⑥ AT fluid	Dexron or M2C-33E-F	
⑦ Hyd. oil	I.S.O. VG32	
⑧ Replace or clean element		
⑨ Brake fluid	FMVSS Dot 3	

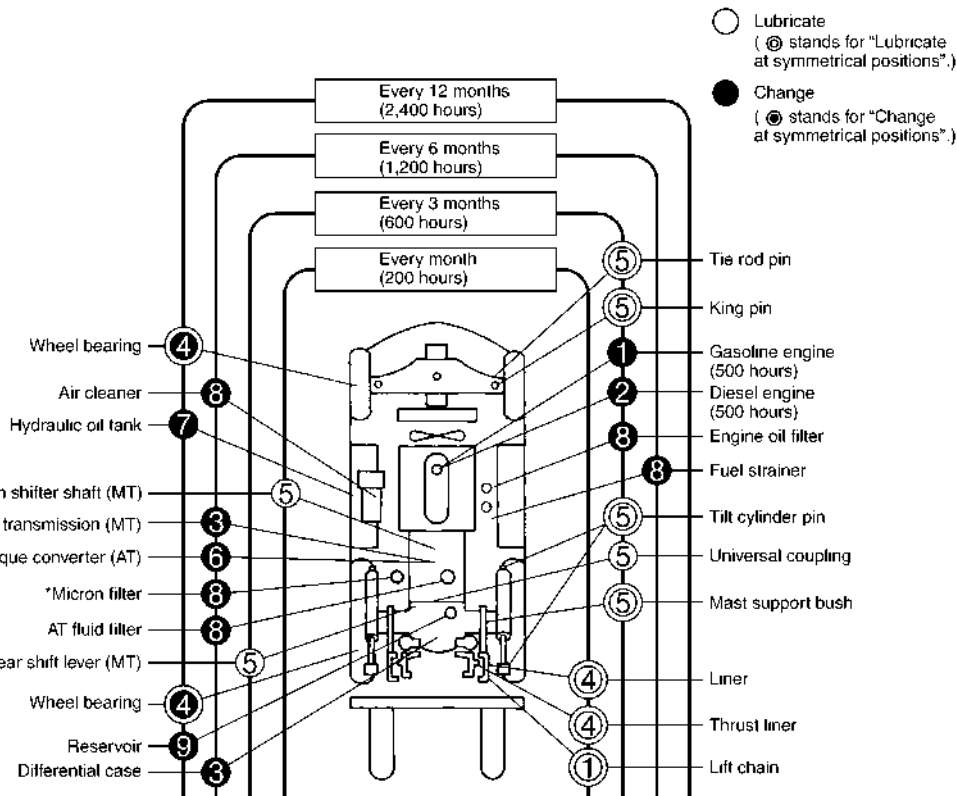

* Replace the micron filter one month after you purchase a vehicle equipped with wet clutch type MT.

MOM3255

PUTTING FORKLIFT IN STORAGE

Putting the forklift in storage involves storing the forklift at the end of each working day or storing the forklift over a long period of time.

Be sure to observe the precautions for forklift storage.

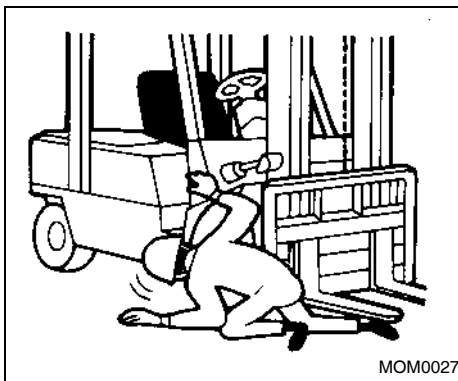

DAILY STORAGE

At the end of the working day, check the forklift. Always park it in the designated location. Put chocks under the tires to prevent the forklift from moving by itself. Check the forklift for water and oil leakages, and other malfunctions.

Keep the body and areas surrounding the driver seat clean. Make it a habit to always keep the forklift clean.

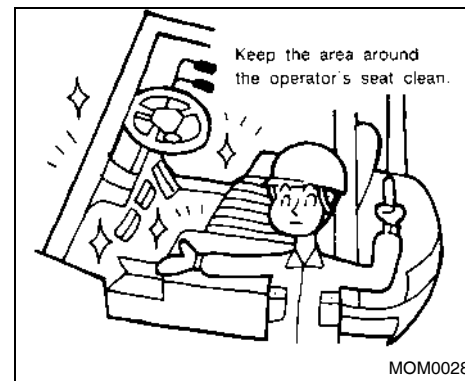

WARNING:

As soon as a malfunction is detected, notify the person responsible for maintenance and take the proper remedial actions or request an authorized UniCarriers FORKLIFT dealer to perform repairs. Do not operate the forklift until the malfunction is corrected.

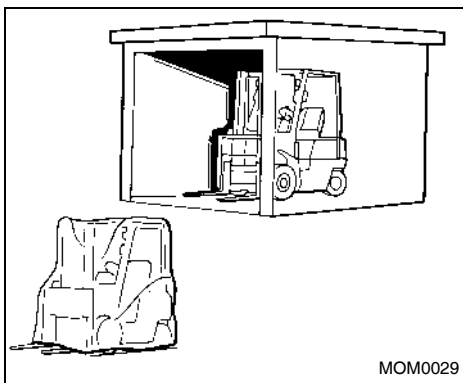

MOM0029

STORAGE OVER A LONG PERIOD OF TIME

When the operation of the forklift is completely suspended for a given period of time, take the following measures and store the forklift in a dry area.

Pre-storage servicing

1. Lubricate the forklift as per "Lubrication Schedule". Change the oil, and coat all exposed areas of hydraulic cylinders with corrosion resistant grease.
2. Completely remove cooling water or fill the radiator with antifreeze to prevent the engine from freezing.

3. In order to protect the inner walls of the cylinders against corrosion, remove the spark plugs from gasoline engines and injection nozzles from diesel engines, and spray a small amount of oil into the cylinders. Then turn the motor over several times with the starter so that oil is distributed throughout the cylinders. Finally, replace the plugs or injection nozzles.
4. Remove the battery, charge it and store it indoors in low fire risk areas.
5. When storing gasoline-engine forklifts [including dual fuel (LPG) forklifts] for a long period of time, idle the engine until all the gasoline is used up. Otherwise, the remaining gasoline will decompose and turn into a rubbery substance, making it very difficult to start the engine.

Servicing the forklift in storage

1. Periodically check the specific gravity and level of the battery fluid. Charge and replenish as necessary.
2. Check various sections of the forklift for stains or corrosion. Clean such areas and coat with a corrosion preventive agent.

NOTE:

- When the forklift cannot be stored indoors, park it on level ground. Cover with a waterproof sheet or protective covering.
- When storing for a long period of time, be sure to consult an authorized UniCarriers FORKLIFT dealer.

Post-storage servicing

1. Remove corrosion resistant grease coated on the exposed areas of the hydraulic cylinders.
2. Check lubrication of all sections of the forklift and cooling water level. If there are impurities or the level is low, change the coolant or top up to the prescribed level.
3. Check the battery fluid level and specific gravity. Be sure to completely charge the battery before putting it back on the forklift. When connecting the battery cables, make sure that the positive and negative terminals are connected correctly.
4. In order to lubricate the inner walls of the cylinders, remove the spark plugs from gasoline engines and the injection nozzles from diesel engines, and spray a small amount of engine oil into the cylinders. Then turn the motor over several times with the starter to thoroughly distribute oil in the cylinders, and replace the plugs or injection nozzles.

DAILY CHECKS

5. As soon as the engine is started, make sure that the oil pressure warning lamp turns off, and continue to warm up the engine so that the various sections of the engine are sufficiently worked in. Also check the instruments, indicating lamps and warning lamps to make sure that they are operating properly.
6. Follow "Function Tests" on page 63.



WARNING:

Perform the daily checks as per "Daily Care" in the Operator's Manual provided separately, and the applicable provisions of local laws and regulations.

UNICARRIERS FORKLIFT GENUINE PARTS



WARNING:

When replacing UniCarriers FORKLIFT parts (including lubricants), be sure to use UniCarriers Forklift genuine parts or the equivalents guaranteed by UniCarriers Corporation.

Any irregularities arising from the use of parts other than those specified above shall not be covered under warranty.

DISPOSAL OF PARTS AND MATERIALS

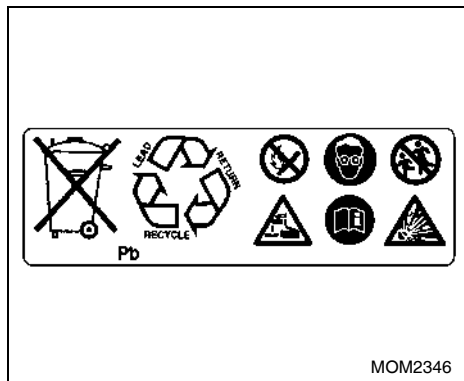

WARNING:

- Used parts and materials such as engine oil, long-life coolant, paint, rags, battery fluid and batteries shall be disposed of according to the applicable provisions of the local laws and regulations.
- Also consult an authorized UniCarriers FORKLIFT dealer.

PRECAUTIONS FOR USING LPG MODEL

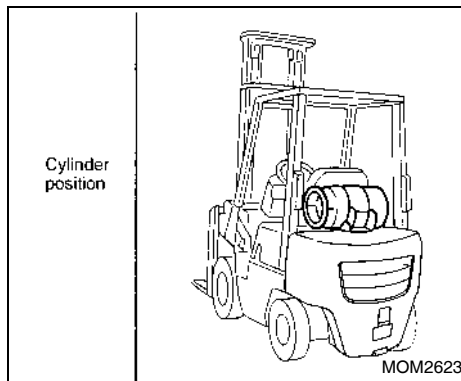

LPG MODEL

WARNING:

- **LPG IS HEAVIER THAN AIR.**
It will settle on your clothes and the surface around you, displacing oxygen necessary for breathing.
- Open flames can cause flash fires.

WARNING:

Check all connections for damage or leaks. If the forklift will not start after you change cylinders, have an authorized, qualified mechanic check it.

When changing LPG (liquified petroleum gas) cylinders, please follow these basic rules:

- Never allow open flames or other sources of ignition in the area.
- Wear protective equipment (i.e. safety glasses, gloves).
- Change only in well ventilated areas.
- Do not use or park near fire.
- Do not expose directly to the sun for extended periods of time.
- Inspect equipment pipe connections for gas leaks at mating sections.
- Only a person who is familiar with replacing LPG should replace the cylinder.
- LPG is heavier than air.

WARNING:

Internal combustion forklifts are not recommended for use in enclosed or confined spaces because of the possible build-up of carbon monoxide gases, which are colorless and odorless, and could cause unconsciousness and/or death.

CYLINDER SIZE

Cylinder size	Vehicle classification	Cylinder			
		Capacity	Weight	Diameter	Length
	1.0 to 3.0 ton (2,000 to 4,000 lb)	36 ℓ (7-7/8 Imp gal, 9-1/2 US gal)	15 kg (33 lb)	320 mm (12.60 in)	660 mm (25.98 in)

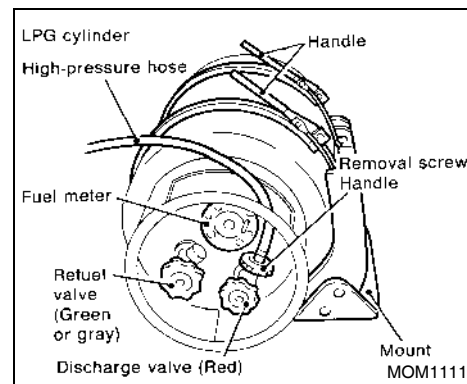

LPG CYLINDER HANDLING INSTRUCTIONS

LPG cylinder replacement

WARNING:

- Replace the cylinder in a well ventilated area.
- While replacing the cylinder, never use or get close to fire.
- Use LPG cylinders with the capacity shown in the table on page 112.

The cylinder is installed on the forklift with the discharge valve on the left side when viewed from the rear of the forklift. The high-pressure hose is connected to the discharge valve with a threaded screw type connector or a quick-coupling device. The LPG cylinder replacement procedure with the thread screw type device is described below.

SWING-OPEN TYPE LPG CYLINDER MOUNT (option)

During forklift service procedures requiring opening of the top panel, the LPG cylinder mount must first be moved to prevent it from interfering with the operator's seat. The optional swing-open type cylinder mount provides easy and convenient cylinder mount movement. Follow the procedure outlined below to replace the LPG cylinder on swing-open type cylinder mount equipped vehicles.

1. The cylinder discharge valve is located on the right side when viewed from the rear of the forklift (swing-back mount equipped forklifts have the discharge valve on the left side). The disconnection procedure for the high-pressure hose and the LPG cylinder is the same for both the swing-back type mount and the swing-open type mount. Perform steps 1 and 2 as described under the item for the swing-back mount.

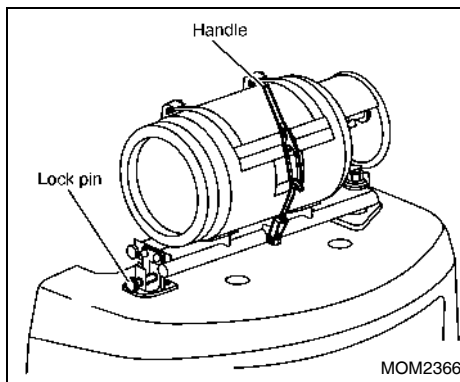

2. Loosen the handle and release it to allow the cylinder to drop.

WARNING:

Do not attempt to replace the LPG cylinder with the mount in the open position. Replace the LPG cylinder only with the mount locked to the top of the counterweight.

NOTE:

The cylinder is heavy. Hold the cylinder firmly during the replacement procedure.

Follow the removal procedure in the reverse order to install the new LPG cylinder.

WARNING:

Connect the high-pressure hose to the cylinder taking care not to twist the hose.

Make sure that the lock handle is in the locked position at the completion of the replacement procedure.

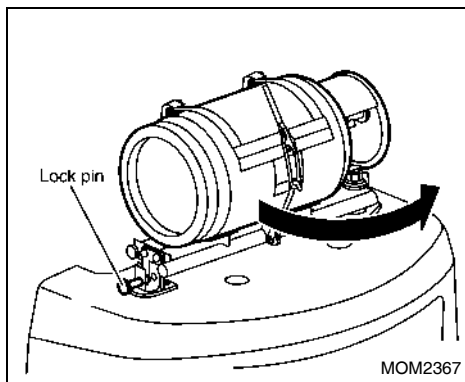

OPENING LPG CYLINDER EQUIPPED FORKLIFT'S TOP PANEL

Swing-open type:

1. Lift the lock pin at the side of the LPG cylinder mount. Rotate the cylinder toward the rear of the mount.

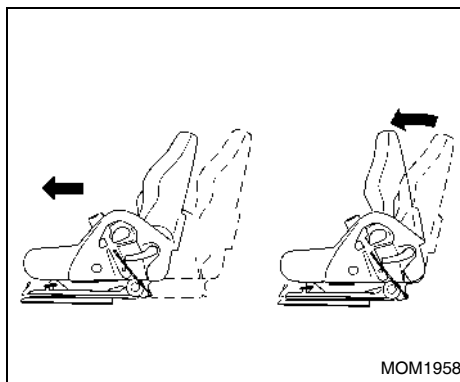

2. Release the lock lever for the LPG cylinder mount.
3. Slide the operator's seat to the front-most position, fully incline the backrest forward and open the top panel. Refer to "Top panel" on page 71.

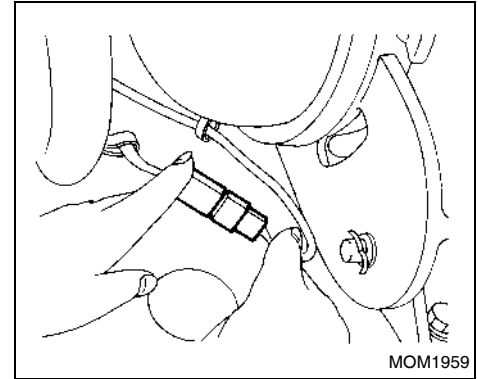
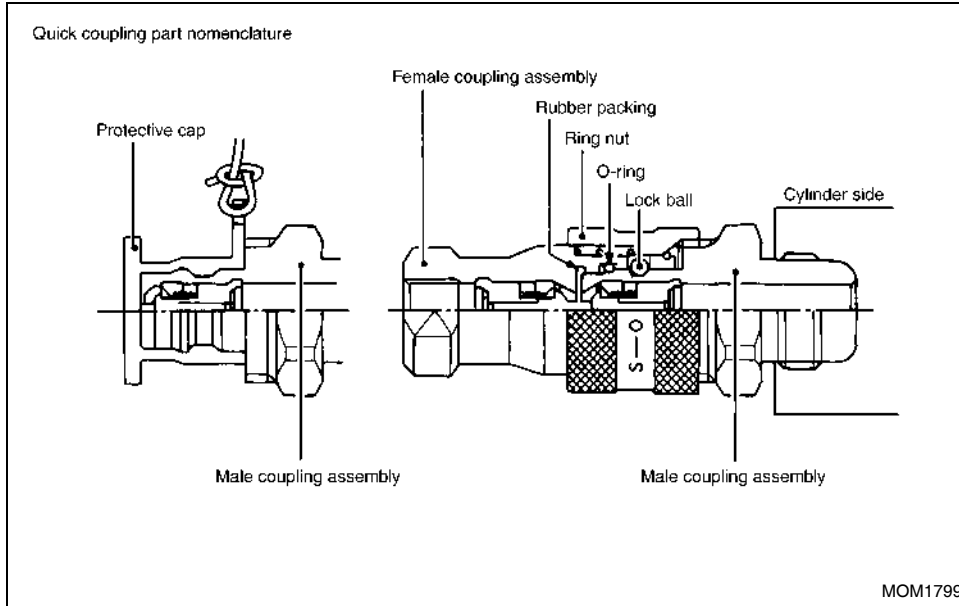

1. Disengage the connector of the LPG fuel meter (for UniCarriers FORKLIFT manufactured outside the U.S.).

CYLINDER REPLACEMENT PROCEDURE WITH QUICK COUPLING

1. Turn the discharge valve (red) at the cylinder side to the right until the valve is completely closed.

Place the fuel-change switch in the LPG position. Wait until the engine stops naturally (fuel is exhausted). Turn the ignition switch to the OFF position.



WARNING:

- Do not operate the refuel valve (green or gray).
- It is very dangerous to open the refuel valve, because it causes LPG to leak out.

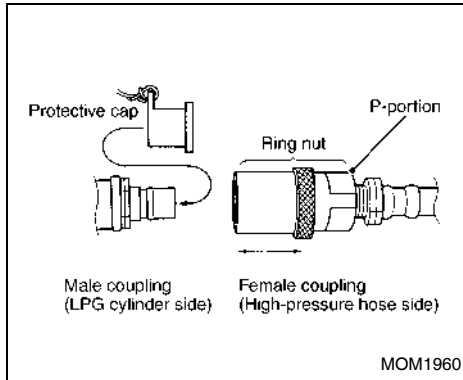

2. Hold part P of the female coupling on the high-pressure hose side with one hand and push it toward the shut-off valve, while sliding the locking part of the coupling toward the high-pressure hose with the other hand.

The male coupling on the LPG cylinder side and the female coupling repel each other and are detached with a snap by force of the springs in them. The couplings snap when they are disengaged.

3. Hold the female coupling and pull it out straight.
4. Put the supplied protective cap on the male coupling.

- When connecting the high-pressure hose to the LPG cylinder, remove the protective cap from the male coupling.
- Align the female coupling with the male coupling, and push the female coupling against the shut-off valve with the part P held with a hand. The locking part of the female coupling then automatically slides towards the high-pressure hose.
- When you further push the coupling against the valve, the locking part automatically slides and engages with the male coupling with a snap. (The couplings snap when they are engaged and locked to each other.) The connection of the high-pressure hose to the LPG cylinder is now complete.
- Slowly open the discharge valve to the full-open position. (Do not open the discharge valve quickly, because this may activate the pressure check valve so that the gas cannot flow properly.)

Place soapy water over the high-pressure hose connection to make sure that no gas leaks occur.

- After making sure that there are no gas leaks, turn the ignition switch to start the engine. If the engine does not start, the pressure check valve may activate to hamper the gas flow. In that case, turn the ignition switch to the OFF position, close the discharge valve, slowly open it and repeat step 1 above.

- If any malfunctions such as gas leaks are noted, close the discharge valve and have the LP gas system checked at an authorized UniCarriers FORKLIFT dealer.

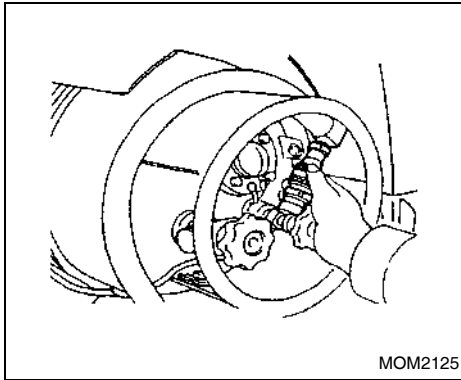

COUPLING CONNECTION PRECAUTIONS

Turn the quick coupling ring nut to the left (counterclockwise when viewed from the hose). Turn the quick coupling to the left (when viewed from the discharge valve) and pull the hose and coupling free of the assembly.

The symbol (S-O) is stamped on the ring nut. (S) indicates the tightening direction. (O) indicates the loosening direction.

NOTE:

- Do not strike the coupling with a mallet or similar object during the removal procedure. Doing so can result in coupling distortion and other damage.
- Be sure to install the protective cap to the male assembly side cap ring after cylinder (container) removal.

- Inspect the male assembly side for dust or other foreign material. Clean the assembly if required. If the female side assembly O-ring is dry, apply a small amount of oil and grease to it so that it rotates smoothly.
- Take care not to damage the O-ring side facing the male assembly during the connection procedure.
- Connect the lock ball. Check that the ring nut has returned to the specified position. Turn the ring nut to the right to thread it into position.

After replacing with a new cylinder, proceed as follows:



WARNING:

- When disconnecting the high-pressure hose, do not stand where the remaining LPG may splash you, otherwise you may be seriously injured.
- Do not disconnect the high-pressure hose when the engine is running. This could cause discharge of LPG and potential serious injury.

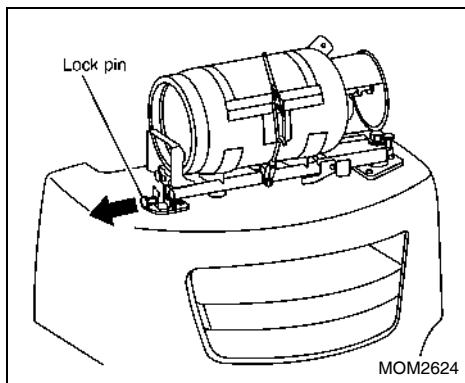

CHANGING LPG CYLINDER

WARNING:

- Before handling the LPG cylinder, check that the cylinder holder swing lock pin and lowering lock pin are securely in the locked positions. Check that the swing lock pin is securely inserted into the base and that the lowering lock pin is securely inserted into the lock hole on the swing rack.
- Check that the LPG cylinder is securely clamped in place by the cylinder clamp bands. Check that there is no looseness in the LPG cylinder or cylinder clamp bands.

- If each holder and the LPG cylinder are not securely fastened, the holder may move unexpectedly, or the LPG cylinder may fall, causing unexpected injury.

REMOVING LPG CYLINDER

1. Disconnect the high-pressure hose from the LPG cylinder.
2. Remove the swing lock pin in order to disengage the lock.

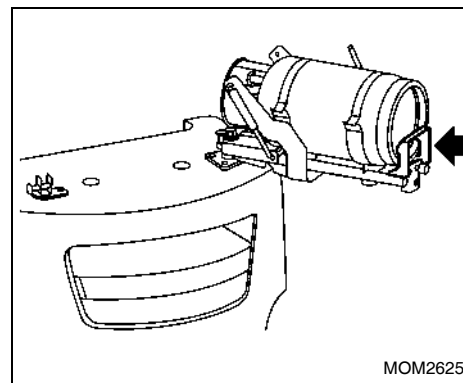

WARNING:

- When handling the LPG cylinder, be sure to grasp it at the top and bottom. If you grasp any other part of the cylinder, there is the danger that your hands may be caught between the cylinder and the holder.
- When swinging the LPG cylinder, be sure to support the cylinder until the swing is completed. If you release the cylinder before the swing is completed, it may move in the opposite direction, or it may swing rapidly, causing unexpected injury.
- When the lock pin is pulled out from the cylinder holder, the weight of the holder and the LPG cylinder cause the holder to drop naturally, possibly resulting in unexpected injury.

When removing the lowering lock pin, be sure to grasp the bottom of the LPG cylinder and keep it firmly supported in the upward direction while handling it.

3. Grasp the bottom of the LPG cylinder and firmly support it in the upward direction while removing the lowering lock pin in order to disengage the lock.

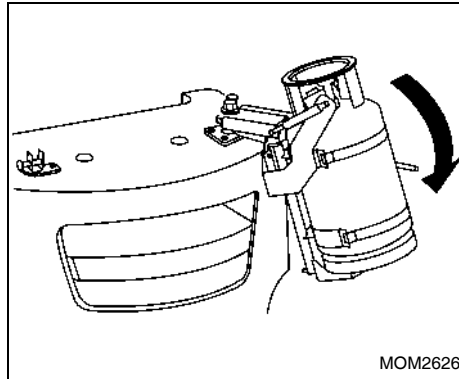

WARNING:

When lowering the LPG cylinder, be sure to securely support the cylinder until it has been fully lowered. In the case of an empty cylinder, if the cylinder is not fully lowered, the cylinder holder may move in the opposite direction, causing unexpected injury.

4. While supporting the bottom of the LPG cylinder, slowly lower it towards the ground. Lower it securely all the way until the cylinder holder stops.

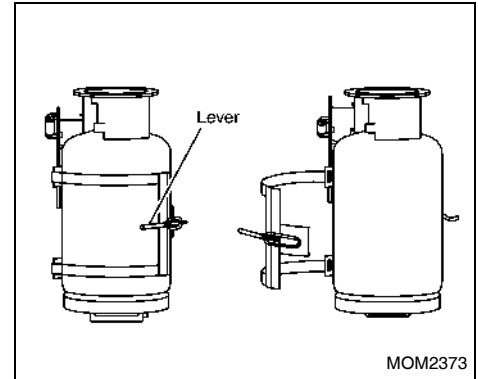

WARNING:

- **LPG cylinder weight (15 kg (33 lb) cylinder)**
Empty cylinder: 15 to 20 kg (33 to 44 lb)
Full cylinder: 35 to 40 kg (77 to 88 lb)

- **Do not place your feet directly below the LPG cylinder. The cylinder is heavy and there is the danger of injury if it falls.**

- **Grasp the cylinder securely with both hands and lift it up to remove it.**

5. While firmly supporting the LPG cylinder by pressing it into the cylinder holder, disengage the lock buckles on the cylinder clamp bands, and fully open the cylinder clamp bands and lock buckles to the left and right.

- Securely grasp the top edge (handle) of the LPG cylinder, and use both hands to lift the cylinder up, remove it from the holder, and lower it to the ground.

INSTALLING LPG CYLINDER

WARNING:

- **LPG cylinder weight (15 kg (33 lb) cylinder)**
Empty cylinder: 15 to 20 kg (33 to 44 lb)
Full cylinder: 35 to 40 kg (77 to 88 lb)
 - **Do not place your feet directly below the LPG cylinder. The cylinder is heavy, and there is the danger of injury if it falls. Grasp the cylinder securely with both hands, and lift it up and place it in the cylinder holder.**
 - **The LPG cylinder will not stay in the holder on its own. Continue to press it securely in the holder until the cylinder clamp bands have been fastened.**
- Turn the LPG cylinder so that the side with the “this end up” arrow faces the rear of the vehicle, then install the LPG cylinder into the holder.

WARNING:

If the cylinder clamp bands are not locked securely, the LPG cylinder may fall, causing unexpected injury.

- While firmly supporting the LPG cylinder by pressing it into the cylinder holder, lock the cylinder clamp bands.

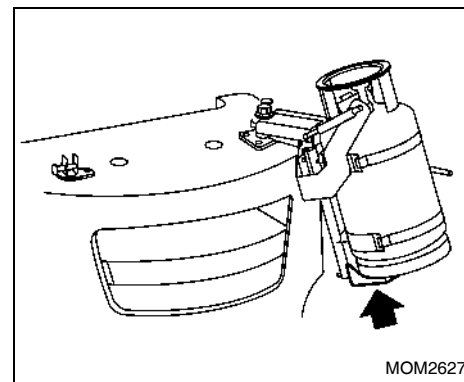

WARNING:

- **When handling the LPG cylinder, be sure to grasp it at the top and bottom. If you grasp any other part of the cylinder, there is the danger that your hands may be caught between the cylinder and the holder.**
 - **Continue to support the LPG cylinder in the upward direction until the cylinder holder is locked in the swing rack. If you stop supporting the cylinder, the cylinder holder may move in the opposite direction (drop), causing unexpected injury.**
- While supporting the bottom of the LPG cylinder, press the LPG cylinder up until it is horizontal.

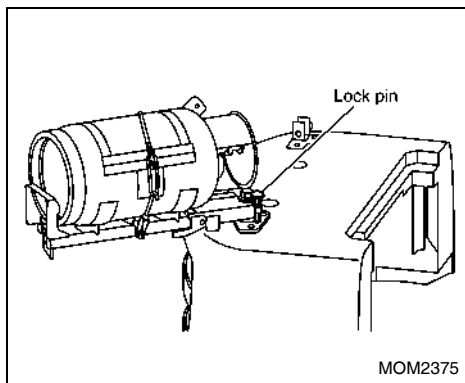

WARNING:

If the lock pin is not locked securely, the cylinder holder may move in the opposite direction (drop), causing unexpected injury. Be sure that the cylinder holder is securely locked onto the swing rack.

4. While firmly supporting the LPG cylinder in the upward direction, insert the lowering lock pin in order to lock the cylinder holder onto the swing rack.

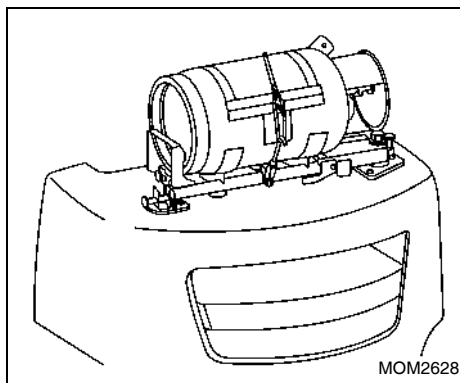

WARNING:

- When handling the LPG cylinder, be sure to grasp it at the top and bottom. If you grasp any other part of the cylinder, there is the danger that your hands may be caught between the cylinder and the holder.
- If the lock pin is not locked securely, there is the danger that the LPG cylinder may move while the forklift is being driven, causing unexpected accidents. Be sure that the swing rack is securely locked onto the base.

5. Insert the swing lock pin in order to lock the cylinder holder onto the base.
6. Connect the high-pressure hose.



WARNING:

- After handling the LPG cylinder, check that the cylinder holder swing lock pin and lowering lock pin are securely in the locked positions. Check that the swing lock pin is securely inserted into the base and that the lowering lock pin is securely inserted into the lock hole on the swing rack.
- Check that the LPG cylinder is securely clamped in place by the cylinder clamp bands. Check that there is no looseness in the cylinder or cylinder clamp bands.
- If each holder and the LPG cylinder are not securely fastened, the holder may move unexpectedly, or the LPG cylinder may fall, causing unexpected injury.
- Connect the high-pressure hose so that it is not twisted.

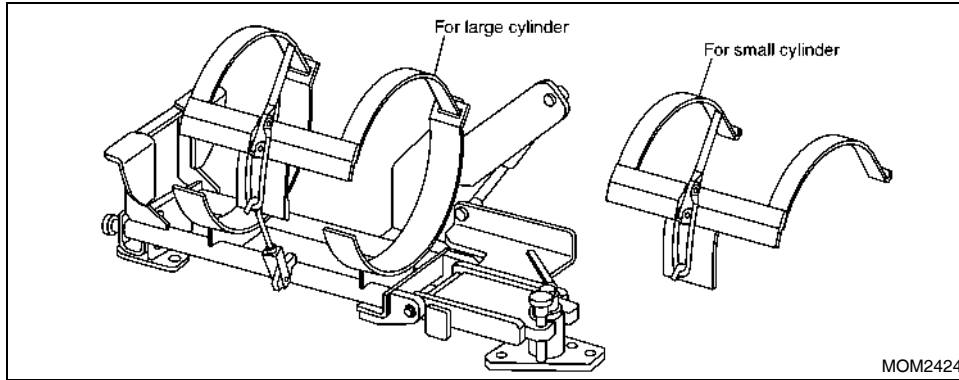

To be chosen the band according to each size of cylinder.

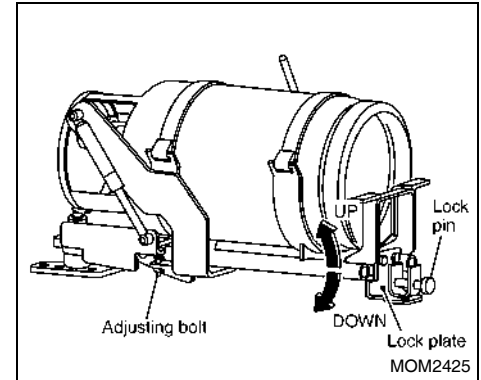

⚠ WARNING:

If the lock pin cannot be inserted into the hole on the lock plate while a full cylinder is installed on the rack, it is possible to adjust the height of the rack using the adjusting bolt as shown in the illustration.

- Tighten the bolt to raise the position
- Loosen the bolt to lower the position

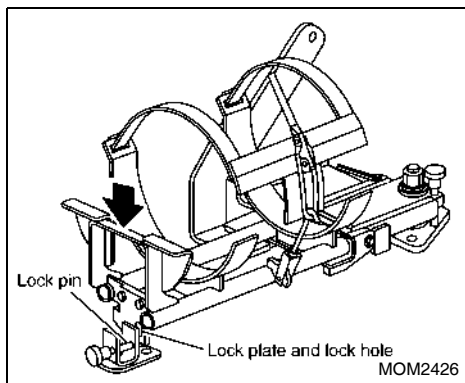

WARNING:

The lock pin can be adjusted for insertion into the lock plate hole while a full cylinder is installed. If an empty cylinder is installed or there is no cylinder, the lock plate hole is out of position. In this case, push down the rack in the direction shown by the arrow until the lock pin can be inserted into the hole.

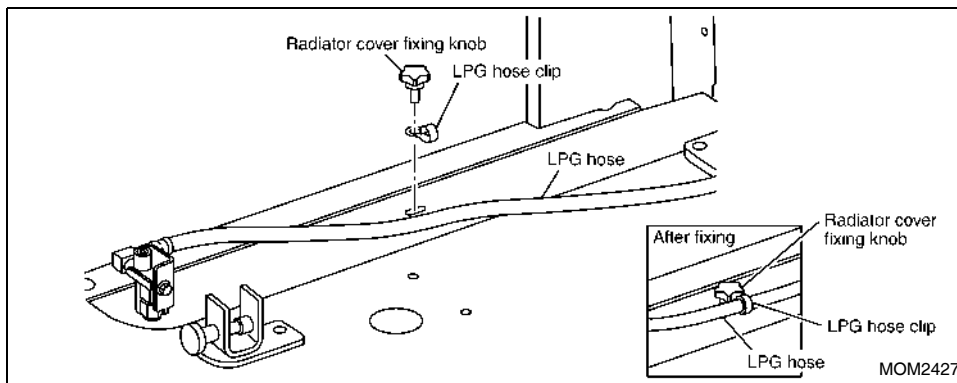

WARNING:

When installing the radiator cover, fix the LPG hose clip using a radiator cover fixing knob, and make sure to fix the LPG hose using the clip (only for the swing rack equipped model).

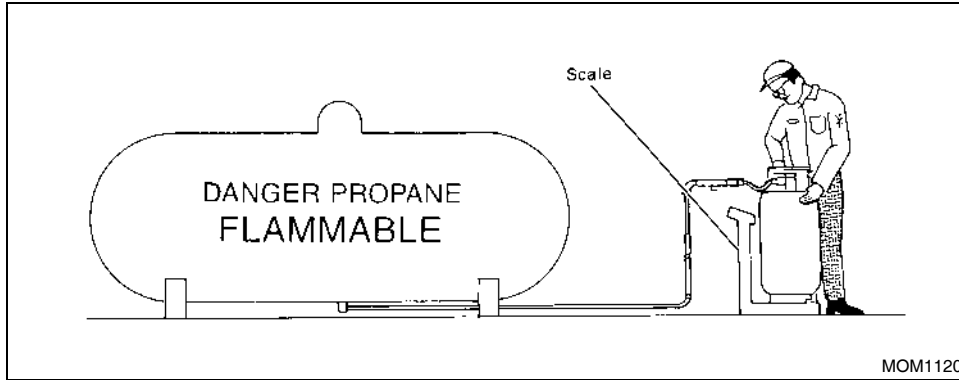

REFILLING LPG CYLINDERS

WARNING:

- Only a trained and authorized person should refill LPG tanks.
- Do not refill cylinders while mounted on a forklift.
- Make sure that you know and understand the proper procedure for filling an LPG cylinder.
- Know all local fire codes.
- If you have any questions about refilling LPG cylinders, please ask your supervisor.
- If problems with filling occur, call your LPG supplier.

The weight scale method to fill the cylinder is highly recommended to protect the environment and to reduce fire hazards. This method will reduce overfilling and the discharge of LPG into the environment.

- Store full and empty cylinders according to local fire codes.
- When filling the LPG cylinder with LPG, always observe the local laws and regulations.

PERIODIC MAINTENANCE SCHEDULE

Before delivery of your new forklift, your dealer provides a pre-delivery inspection and adjustment service specified by the factory and designed to ensure satisfactory performance.

The following tables list the servicing required to keep your forklift operating at peak mechanical condition and should be attended to as indicated, preferably by an authorized UniCarriers FORKLIFT dealer.

MAINTENANCE OPERATION	MAINTENANCE INTERVAL															
	Months	1	2	3	4	5	6	7	8	9	10	11	12	18	
Periodic maintenance should be performed after specified intervals have elapsed in months or hours, whichever comes first.	Months	1	2	3	4	5	6	7	8	9	10	11	12	18	
	Hundreds of hours	2	4	6	8	10	12	14	16	18	20	22	24	36	
LPG FUEL SYSTEM																
1. Piping or pipe connector portion for gas leakage		I	I	I	I	I	I	I	I	I	I	I	I	I	
2. Tar in vaporizer		D	D	D	D	D	D	D	D	D	D	D	D	D	
3. Piping or pipe connector portion for damage		I	I	I	I	I	I	I	I	I	I	I	I	I	
4. Mounting bracket of LPG cylinder for looseness or damage		I	I	I	I	I	I	I	I	I	I	I	I	I	
5. Piping or pipe connector portion for gas leakage (1)														I	I
6. Filter for LPG				C			C			C			R	C	

NOTE: (1) When the LPG cylinder is replaced, inspect pipe connectors for gas leakage with soapy water.

Abbreviations: I = Inspect. Correct or replace if necessary. D = Drain C = Clean R = Replace

Also refer to Maintenance Schedule on page 102.

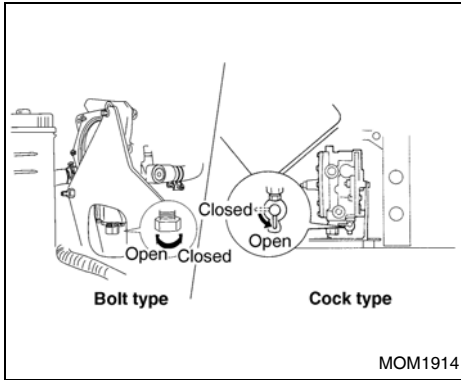

DRAINING OF TAR FROM THE VAPORIZER (LPG - gasoline dual fuel forklift)



CAUTION:

This should only be done by a trained & authorized person.

The vaporizer is an apparatus used during LPG operation to control and reduce fuel pressure within the LPG cylinder and regulate vaporization. The vaporization process produces tar (sticky liquid) which accumulates in the vaporizer.

When or if tar accumulation becomes excessive, emission levels and idling speed adjustment could be adversely affected. Tar must be

purged from the vaporizer at least once a month.

1. The tar purging procedure should be performed when the engine is at the operating temperature (warm).
2. Shut off (close) LPG cylinder tank, (red) discharge the valve and then idle.
3. Turn the ignition key to the OFF position.
4. Get off the forklift after pulling out the key to open the top panel. Refer to "Top panel" on page 71.
5. Put a cloth for collecting tar on the outlet.
6. For the valve cock type, open the purge valve cock. For the plug (bolt) type, slowly remove the plug.
7. Tar will drip. When it stops, the procedure is complete.
8. Close the purge valve cock or fix the purge plug (bolt). If tar adheres to the body or surrounding areas, completely wipe it off with a cloth.
9. Close the top panel to complete the work.



WARNING:

Do not touch the vaporizer or its surrounding parts at high temperature, as it may cause burns. Whenever operating the purge valve cock or plug, always wear protective gloves.

Stopping

Gasoline engine vehicle:

To stop the engine, turn the ignition key to the OFF position.

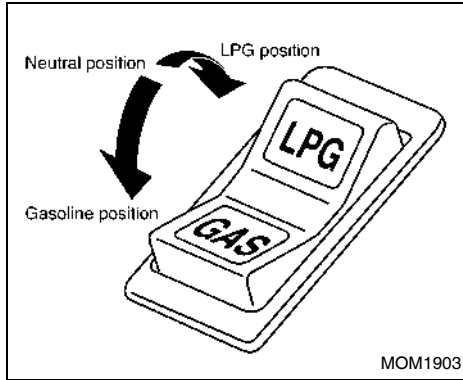

LPG - GASOLINE DUAL FUEL FORKLIFT



WARNING:

Carefully follow the procedures below when turning the engine off after LPG operation:

1. Completely close the discharge valve (red).
2. Press the fuel-change switch to set the neutral position.
3. Let the engine idle until it stops.
4. Make sure that all of the remaining LPG (in the piping and other receptacles) has been used. After the engine stops, turn the ignition key to the OFF position.

- If the forklift is not used for several hours after the operation, park the forklift with the fuel-change switch set to the GAS position. This helps the engine start more easily the next time.
- After completion of operation and before storing the forklift for an extended period, completely close the discharge valve (red). Check the engine for gas leakage. Refer to "LPG cylinder replacement" on page 112.
- In the event of LPG leakage, an accident or some other malfunction, immediately and completely close the discharge valve (red). Have your LPG system checked at an authorized UniCarriers FORKLIFT dealer.

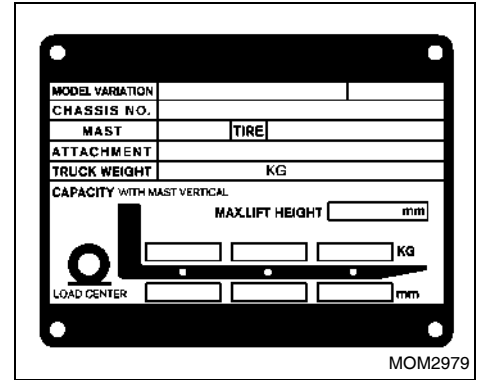

LOAD CHART

The load chart, attached to front panel, indicates all necessary information regarding the type of attachments, lifting capacity, etc.



WARNING:

Do not exceed the rated capacity of the forklift.

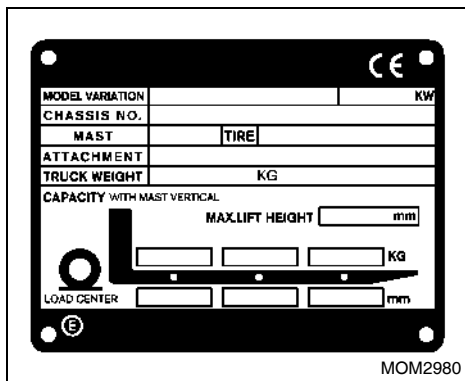

For countries where a forklift with the CE marking must be used.

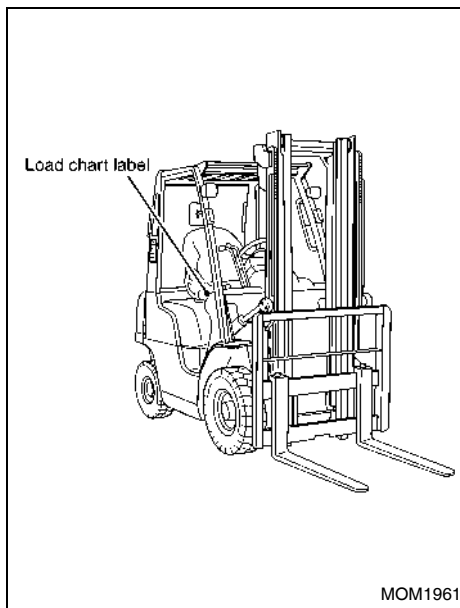

LOAD CHART LABEL

The load chart label is attached to the right side of the front panel.

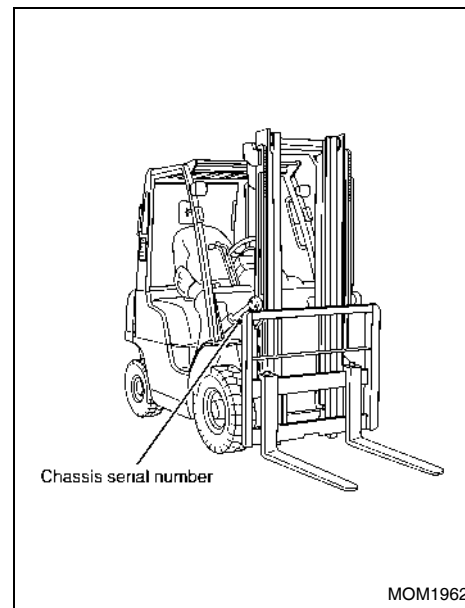

CHASSIS SERIAL NUMBER

The chassis serial number is stamped on the front panel.

IDENTIFICATION NUMBERS

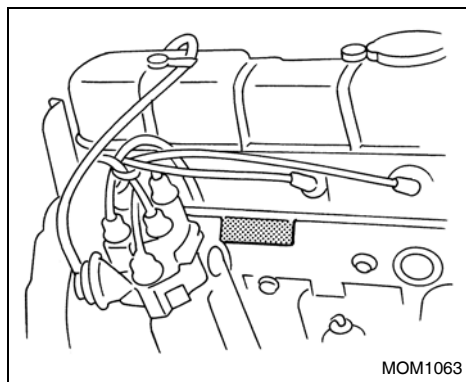

ENGINE SERIAL NUMBER

GASOLINE ENGINE (Carburetor
type)

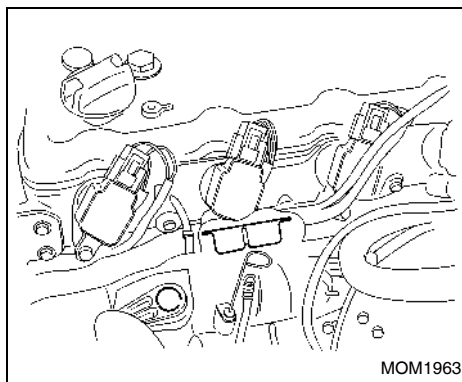

GASOLINE ENGINE (K15, K21, K25
EGI type)

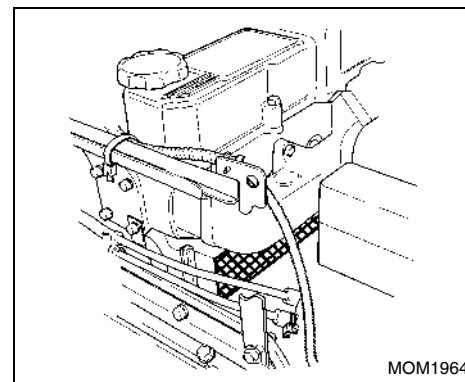

DIESEL ENGINE (S4Q2)

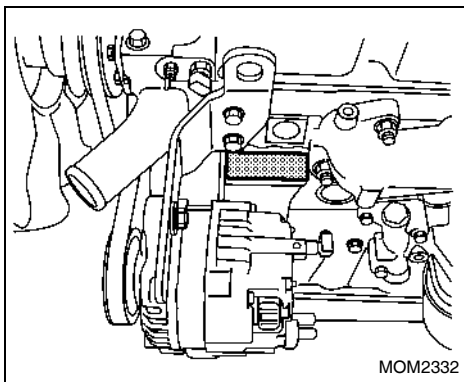

MOM2332

DIESEL ENGINE (QD32)

DIESEL PARTICLE FILTER [DPF] (OPTION FOR DIESEL FORKLIFT ONLY)

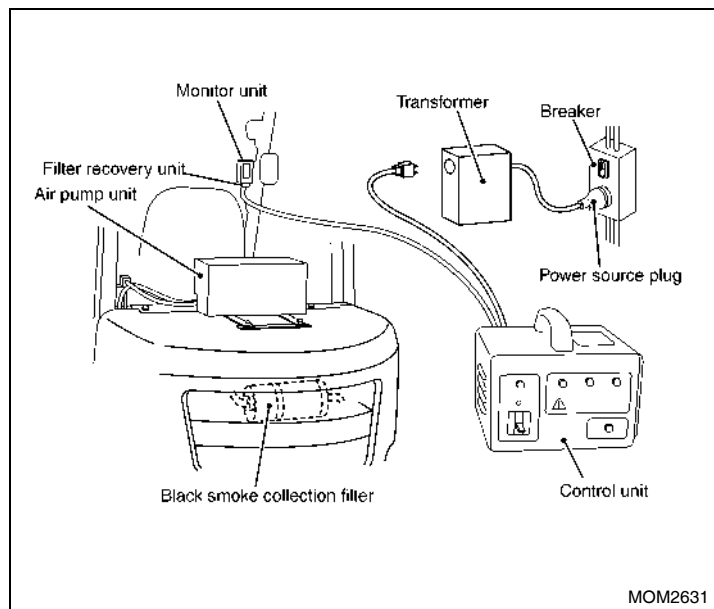

OVERVIEW OF DPF

Diesel Particle Filter (DPF) traps black smoke particles (“soot”) in the exhaust gas from the diesel engine.

The DPF system can regenerate the DPF by burning the accumulated soot in the DPF with the electrical heater integrated in the muffler.

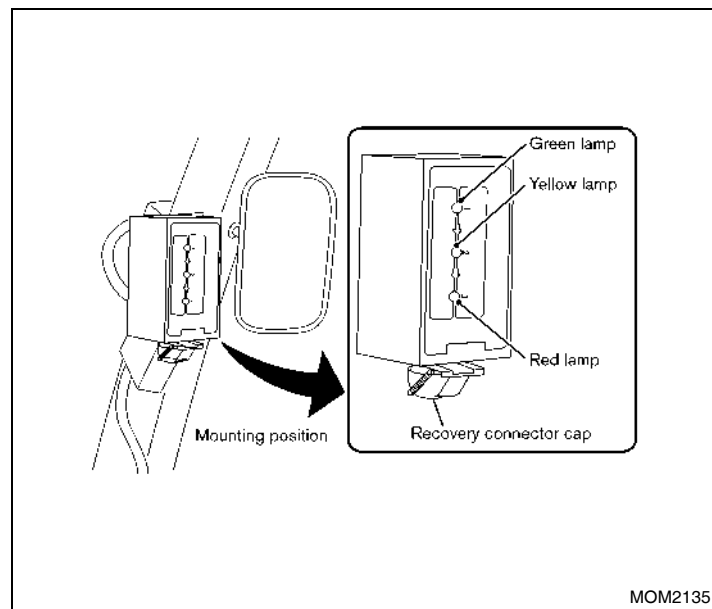

This DPF system consists of the monitor, the separate controller and the air pump unit.

The level of accumulated soot in the DPF can be confirmed by the monitor installed on the overhead guard pillar during forklift operation.

The remaining time to the completion of regeneration can be monitored by the same monitor when regenerating the DPF.

**WARNING:**

As soon as a malfunction is detected, notify the person responsible for maintenance and take the proper actions or consult an authorized UniCarriers FORKLIFT dealer to carry out repairs. Do not operate the forklift until the malfunction is corrected.

**CAUTION:**

Be sure to close the cap of the regeneration connector when regeneration is not being performed.

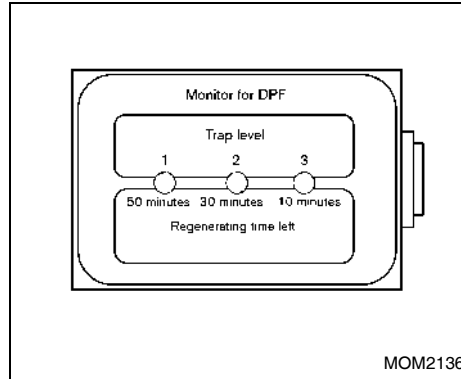
**THE MONITOR**

The 3-stage lamp in the monitor displays “**Trap level**”, the level of soot accumulated during forklift operation, and it displays “**Regenerating time left**”, the time remaining for regeneration when performing regeneration of the DPF.

Display of “Trap level”

The 3-stage lamp displays “Trap level” during forklift operation as shown in the following table.

Lamp	Trap Level	The condition of DPF
Green Lamp	ON 1	OK: Trap level is good
Yellow Lamp	ON 2	Caution: Recommend regeneration
Red Lamp	ON 3	Warning: Should regenerate immediately

NOTE:

- When the key switch is turned on, all lamps are temporarily illuminated for an initial check, and they turn off after 1 second.
- If all of the lamps blink at the same time, the condition is that the DPF is clogged, and the DPF should be checked and repaired by an authorized UniCarriers FORKLIFT dealer.

Lamp		The remaining time of regeneration
Green Lamp	ON	50 - 30 minutes
Yellow Lamp	ON	30 - 10 minutes
Red Lamp	ON	10 - 5 minutes

Display of “Regenerating time left”

The 3-stage lamp displays “Regenerating time left” during the DPF regeneration as shown in the above table.

NOTE:

When the start button is pushed after connecting the separated controller, all lamps are temporarily illuminated for an initial check, and they turn off after 1 second.

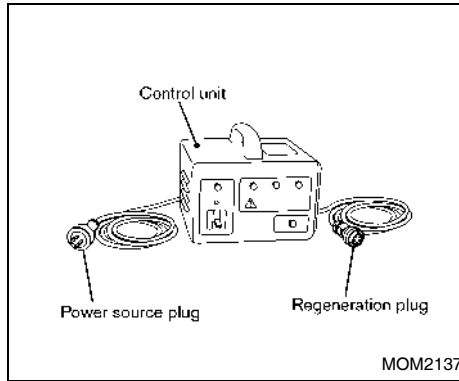

SEPARATE CONTROLLER

The separate controller is only used for regenerating the DPF.

The input plug is connected to an AC power supply, and the regeneration plug is connected to the regeneration connector on the monitor to operate this controller.

This controller displays the current status of the DPF regeneration.

Any malfunction detected by the separate controller is indicated by a warning buzzer and lamp.

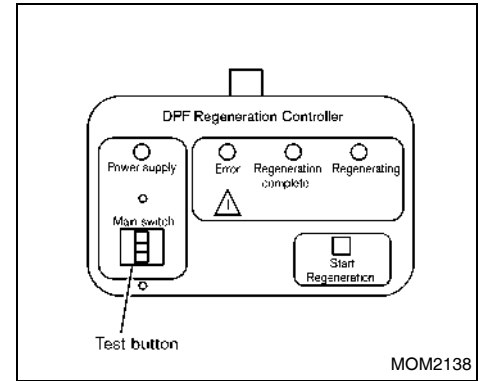

Input plug

This plug is connected to the AC power supply (AC 220V ±10%).

Regeneration plug

This plug is connected to the regeneration connector on the monitor.

Main switch

This switch activates the DPF regeneration system.

This switch also acts as the breaker of the AC power supply.

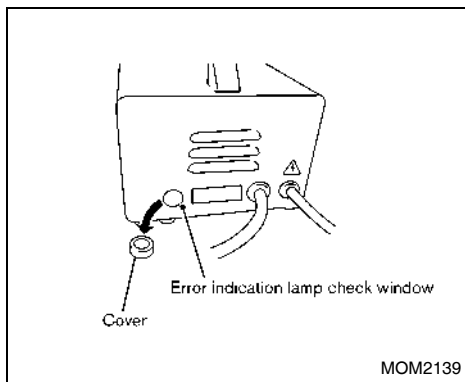

Test button

This button is used to check the breaker function of the main switch as follows.

- Connect the input plug to the AC power supply.
- Turn the main switch on.
- Push the test button.
- If the main switch is automatically changed to the "OFF" position, the breaker function is normal.

Power supply lamp (Yellow)

This lamp is illuminated when the main switch is turned on.

Start regeneration button (Blue)

This button is used for starting regeneration.

Regenerating lamp (White)

This lamp is illuminated during regeneration and will turn off when regeneration is complete.

Regeneration complete lamp (Green)

This lamp is illuminated when regeneration completes normally.

Error lamp (Red)

This lamp is illuminated when the controller detects any malfunction.

The warning buzzer will also sound at the same time.

Error indication lamp check window

The error indication lamp is checked through this window.

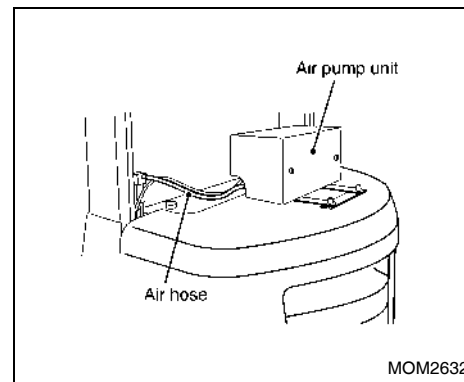

THE AIR PUMP UNIT

The air pump unit is mounted on the counterweight.

This unit provides the air for the DPF to burn the accumulated soot during regeneration.



WARNING:

As soon as a malfunction is detected, notify the person responsible for maintenance and take the proper actions or consult an authorized UniCarriers FORKLIFT dealer to carry out repairs. Do not operate the forklift until the malfunction is corrected.

**CAUTION:**

If the DPF is regenerated for a long period of time with the pump air filter or pump air hose clogged, the DPF system does not perform correctly and will be damaged.

NOTE:

- The pump air filter and air hose inside the air pump unit should be replaced periodically.
- The pump air filter should be replaced every 1 year or 2,000 hours, whichever comes first.
- The pump air hose should be replaced every 1 year.

TRAPPING SOOT**Procedure**

The following procedure is required for the DPF to trap soot properly.

1. Confirm that the regeneration plug is disconnected and the cap of the regeneration connector is closed.
2. Confirm that all lamps on the monitor are illuminated for the initial check when the key switch is turned on, and that all lamps turn off after 1 second.
3. Start the engine and confirm that none of the lamps blink and confirm that the lamps are illuminated according to the current accumulation level.
4. Confirm the condition of the lamps at certain intervals during forklift operation.
5. Perform regeneration when “Trap level 2” (Yellow) is illuminated to keep the DPF in good condition.
6. If the regeneration is not performed until “Trap level 3” (Red) is illuminated, perform the regeneration immediately.

Lamp		Trap Level	The condition of DPF
Green Lamp	ON	1	OK: Trap level is good
Yellow Lamp	ON	2	Caution: Recommend regeneration
Red Lamp	ON	3	Warning: Should regenerate immediately

Daily checks

The following items must be checked every day when operating the forklift.

1. Any black smoke from the muffler does not appear while the engine is running.
2. The time until “Trap level 2” (Yellow) is illuminated does not become significantly shorter.

(It should be more than 3 hours.)

**WARNING:**

As soon as a malfunction is detected, notify the person responsible for maintenance and take the proper actions or consult an authorized UniCarriers FORKLIFT dealer to carry out repairs. Do not operate the forklift until the malfunction is corrected.



CAUTION:

- Do not check lamps on the monitor during traveling and lifting. For safety reasons, check the lamps when not traveling and lifting.
- Try to perform regenerating DPF as soon as “Trap level 2” (Yellow) is illuminated.

REGENERATING DPF

Procedure

In order to regenerate the DPF, the separate controller must be connected to the monitor.

The time to complete the DPF regeneration takes approximately 50 minutes regardless of the amount of soot that is trapped.

The following procedure is required in order to perform regeneration of the DPF correctly.

1. Confirm that the engine is not running and the key is removed from the key switch.
2. Confirm that the circuit breaker of the AC power supply is turned off and the main switch of the separate controller is turned off.
3. Connect the input plug to the AC power supply.
4. Connect the regeneration plug to the regeneration connector on the monitor and make sure that the location of the mark on the plug and connector are correct.

Plug in until a clicking sound is heard. If the connector is not connected correctly, regeneration will not start.

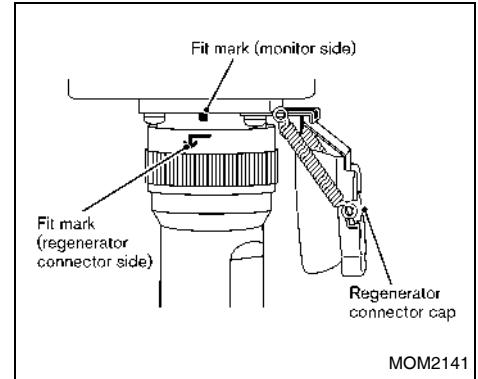

5. Turn on the circuit breaker of the AC power supply.
6. Turn on the main switch of the separate controller and confirm that the power supply lamp (Yellow) is illuminated.
7. Push the start regeneration button (Blue button).
8. The regenerating lamp (White) is illuminated, and the regeneration of the DPF starts.
 - When the start button is pushed, all lamps are illuminated for the initial check, and they turn off after 1 second.
 - The time to finish regenerating the DPF takes approximately 50 minutes regardless of the amount of soot that is trapped.

Lamp		The remaining time of regeneration
Green Lamp	ON	50 - 30 minutes
Yellow Lamp	ON	30 - 10 minutes
Red Lamp	ON	10 - 5 minutes

- The regeneration of the DPF should not be interrupted once started.
 - The remaining time to complete regeneration can be confirmed on the monitor.
9. If the regeneration completes normally, the regenerating lamp (White) turns off, and the regeneration complete lamp (Green) is illuminated.
 10. Turn off the main switch of the separate controller and confirm that the power supply lamp (Yellow) turns off.
 11. Turn off the circuit breaker of the AC power supply.

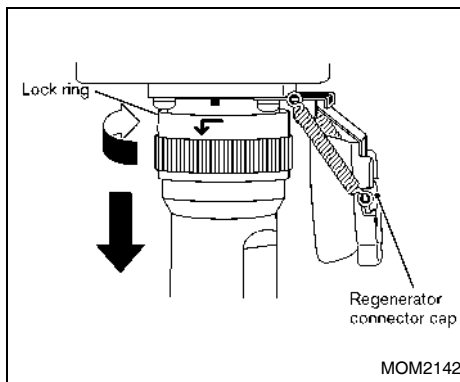

12. Disconnect the regeneration plug from the regeneration connector of the monitor by rotating the lock ring in the direction shown in the figure.
13. Close the cap of the regeneration connector.
14. Confirm that all lamps in the monitor are illuminated for the initial check when the key switch is turned on, and confirm that all lamps turn off after 1 second.
15. Start the engine and confirm that no lamps blink and confirm that only "Trap level 1" (Green) is illuminated.

⚠ WARNING:

- As soon as a malfunction is detected, notify the person responsible for maintenance and take the proper actions or consult an authorized UniCarriers FORKLIFT dealer to carry out repairs. Do not operate the forklift until the malfunction is corrected.
- Before starting the regeneration, park the forklift in a well ventilated location and make sure that there are no flammable items in the vicinity of the forklift.
- Do not touch the muffler during the regeneration to avoid any burn hazards.

⚠ CAUTION:

Make sure that the separate controller is free from any water and rain to avoid electrical damage and leakage.

Malfunction during regeneration

If any malfunction is detected by the separate controller during regeneration, the error lamp (Red) will be illuminated and the warning buzzer will also sound at the same time.

The following procedure is required for clarification of the malfunction.

1. Remove the cover of the error indication window on the rear side of the separate controller.
2. Confirm the condition of the error indication lamp through the error indication lamp check window and record the condition of this lamp.
3. Install the cover on the error indication window on the rear side of the separate controller.
4. Turn off the main switch of the separate controller and turn off the circuit breaker of the AC power supply.

Interruption of the regeneration during regenerating

Regeneration of the DPF should not be interrupted once it is started except in case of emergencies.

If the regeneration is interrupted, the regeneration should be performed again from the beginning.



WARNING:

- **Do not start the engine for at least 15 minutes in case the regeneration is interrupted.**
- **If the engine is started immediately after interrupting the regeneration, the DPF will be damaged.**

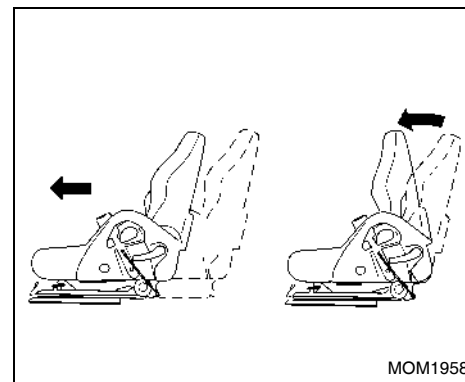

Swing-back type, slide type:

Slide the operator's seat to the frontmost position, fully incline the backrest forward, and open the top panel. Refer to "Top panel" on page 71.

SPECIFICATIONS

Main Truck Specifications

1F1 series

Item		Model	1F1A15U/WU [1F1M15U/WU]	P1F1A15JU/DU	P1F1A15U/WU	F1F1A15U [F1F1M15U]
Load capacity		kg (lb)	1500 (3000)	1500 (3000)	1500 (3000)	1500 (3000)
Load center		mm (in)	500 (19.7)	500 (19.7)	500 (19.7)	500 (19.7)
Maximum fork height		mm (in)	3000 (118.1)	3000 (118.1)	3000 (118.1)	3000 (118.1)
Free lift		mm (in)	155 (6.1)	155 (6.1)	155 (6.1)	155 (6.1)
Tilt angle	Forward	degree	6	6	6	6
	Backward	degree	12	12	12	12
Overall length (without fork length)		mm (in)	2135 (84.1)	2135 (84.1)	2135 (84.1)	2135 (84.1)
Overall width	Single tire	mm (in)	1065 (41.9)	1065 (41.9)	1065 (41.9)	1065 (41.9)
	Double tire	mm (in)	1480 (58.3)	1480 (58.3)	1480 (58.3)	1480 (58.3)
Overall height	Mast (lowered)	mm (in)	1995 (78.5)	1995 (78.5)	1995 (78.5)	1995 (78.5)
	Mast (extended) with backrest	mm (in)	3945 (155.3)	3945 (155.3)	3945 (155.3)	3945 (155.3)
	Overhead guard	mm (in)	2115 (83.3)	2115 (83.3)	2115 (83.3)	2115 (83.3)
Wheelbase		mm (in)	1400 (55.1)	1400 (55.1)	1400 (55.1)	1400 (55.1)
Front overhang		mm (in)	400 (15.7)	400 (15.7)	400 (15.7)	400 (15.7)
Rear overhang		mm (in)	460 (18.1)	460 (18.1)	460 (18.1)	460 (18.1)
Front tread	Single tire	mm (in)	890 (35.0)	890 (35.0)	890 (35.0)	890 (35.0)
	Double tire	mm (in)	1095 (43.1)	1095 (43.1)	1095 (43.1)	1095 (43.1)
Rear tread		mm (in)	900 (35.4)	900 (35.4)	900 (35.4)	900 (35.4)
Minimum turning radius	Outside	mm (in)	1950 (76.8)	1950 (76.8)	1950 (76.8)	1950 (76.8)
Fork length (standard)		mm (in)	1070 (42.1)	1070 (42.1)	1070 (42.1)	1070 (42.1)
Fork (width x thickness)		mm (in)	100 x 35 (3.9 x 1.4)	100 x 35 (3.9 x 1.4)	100 x 35 (3.9 x 1.4)	100 x 35 (3.9 x 1.4)
Ground clearance	Under mast	mm (in)	115 (4.5)	115 (4.5)	115 (4.5)	115 (4.5)
	Under power unit	mm (in)	135 (5.3)	135 (5.3)	135 (5.3)	135 (5.3)
	Under frame	mm (in)	150 (5.9)	150 (5.9)	150 (5.9)	150 (5.9)

1F1 series

Item			Model		1F1A15U/WU [1F1M15U/WU]	P1F1A15JU/DU	P1F1A15U/WU	F1F1A15U [F1F1M15U]
Lifting speed	2W lifting	Full load	mm/sec (FPM)	550 (108.3)	620 (122.0)	580 (114.2)	670 (131.9)	
		No load	mm/sec (FPM)	630 (124.0)	650 (127.9)	650 (127.9)	710 (139.8)	
	2F lifting	Full load	mm/sec (FPM)	530 (104.3)	550 (108.3)	530 (104.3)	600 (118.1)	
		No load	mm/sec (FPM)	570 (112.2)	590 (116.1)	590 (116.1)	640 (126.0)	
	3F lifting	Full load	mm/sec (FPM)	540 (106.3)	560 (110.2)	530 (104.3)	600 (118.1)	
		No load	mm/sec (FPM)	580 (114.2)	590 (116.1)	590 (116.1)	640 (126.0)	
Lowering speed	2W lifting	Full load	mm/sec (FPM)	500 (98.4)	500 (98.4)	500 (98.4)	500 (98.4)	
		No load	mm/sec (FPM)	500 (98.4)	500 (98.4)	500 (98.4)	500 (98.4)	
	2F lifting	Full load	mm/sec (FPM)	480 (94.5)	480 (94.5)	480 (94.5)	480 (94.5)	
		No load	mm/sec (FPM)	310 (61.0)	310 (61.0)	310 (61.0)	310 (61.0)	
	3F lifting	Full load	mm/sec (FPM)	480 (94.5)	480 (94.5)	480 (94.5)	480 (94.5)	
		No load	mm/sec (FPM)	370 (72.8)	370 (72.8)	370 (72.8)	370 (72.8)	
Travel speed	Forward	Full load	km/h (MPH)	19 (12)	19 (12)	19 (12)	19 (12)	
		No load	km/h (MPH)	19 (12)	19 (12)	19 (12)	19 (12)	
Drawbar pull	Full load (travel)		N (kg, lb)	12250 (1249, 2753) [10800 (1101, 2427)]	16450 (1677, 3698)	15200 (1550, 3417)	14240 (1452, 3201)	
	No load		N (kg, lb)	10600 (1081, 2382)	11000 (1122, 2472)	11000 (1122, 2472)	10700 (1091, 2405)	
Gradeability	Full load (travel)		tanθ (%)	35	42	46	34	
	No load		tanθ (%)	28	28	28	28	
Truck weight (no load)	Single tire		kg (lb)	2635 (5810)	2635 (5810)	2635 (5810)	2690 (5931)	
	Double tire		kg (lb)	2740 (6042)	2740 (6042)	2740 (6042)	2795 (6163)	
ENGINE	Model			K15	K21	K21	S4Q2	
	Displacement		cm ³ (cu in)	1486 (90.68)	2065 (126.01)	2065 (126.01)	2505 (152.86)	
	Rated output		kW (HP)/rpm	26 (35)/2450	41 (55)/2700	34 (46)/2200	36 (48)/2500	
	Rated torque		N·m (ft·lb)/rpm	109 (80)/2000	151 (111)/2000	158 (117)/1600	149 (110)/2000	

1F1 series

Item		Model	1F1A18U/WU	P1F1A18JU/DU	P1F1A18U/WU	F1F1A18U
Load capacity		kg (lb)	1750 (3500)	1750 (3500)	1750 (3500)	1750 (3500)
Load center		mm (in)	500 (19.7)	500 (19.7)	500 (19.7)	500 (19.7)
Maximum fork height		mm (in)	3000 (118.1)	3000 (118.1)	3000 (118.1)	3000 (118.1)
Free lift		mm (in)	155 (6.1)	155 (6.1)	155 (6.1)	155 (6.1)
Tilt angle	Forward	degree	6	6	6	6
	Backward	degree	12	12	12	12
Overall length (without fork length)		mm (in)	2135 (84.1)	2135 (84.1)	2135 (84.1)	2135 (84.1)
Overall width	Single tire	mm (in)	1065 (41.9)	1065 (41.9)	1065 (41.9)	1065 (41.9)
	Double tire	mm (in)	1480 (58.3)	1480 (58.3)	1480 (58.3)	1480 (58.3)
Overall height	Mast (lowered)	mm (in)	1995 (78.5)	1995 (78.5)	1995 (78.5)	1995 (78.5)
	Mast (extended) with backrest	mm (in)	3945 (155.3)	3945 (155.3)	3945 (155.3)	3945 (155.3)
	Overhead guard	mm (in)	2115 (83.3)	2115 (83.3)	2115 (83.3)	2115 (83.3)
Wheelbase		mm (in)	1400 (55.1)	1400 (55.1)	1400 (55.1)	1400 (55.1)
Front overhang		mm (in)	400 (15.7)	400 (15.7)	400 (15.7)	400 (15.7)
Rear overhang		mm (in)	485 (19.1)	485 (19.1)	485 (19.1)	485 (19.1)
Front tread	Single tire	mm (in)	890 (35.0)	890 (35.0)	890 (35.0)	890 (35.0)
	Double tire	mm (in)	1095 (43.1)	1095 (43.1)	1095 (43.1)	1095 (43.1)
Rear tread		mm (in)	900 (35.4)	900 (35.4)	900 (35.4)	900 (35.4)
Minimum turning radius	Outside	mm (in)	1990 (78.3)	1990 (78.3)	1990 (78.3)	1990 (78.3)
Fork length (standard)		mm (in)	1070 (42.1)	1070 (42.1)	1070 (42.1)	1070 (42.1)
Fork (width x thickness)		mm (in)	100 x 35 (3.9 x 1.4)	100 x 35 (3.9 x 1.4)	100 x 35 (3.9 x 1.4)	100 x 35 (3.9 x 1.4)
Ground clearance	Under mast	mm (in)	115 (4.5)	115 (4.5)	115 (4.5)	115 (4.5)
	Under power unit	mm (in)	135 (5.3)	135 (5.3)	135 (5.3)	135 (5.3)
	Under frame	mm (in)	150 (5.9)	150 (5.9)	150 (5.9)	150 (5.9)

1F1 series

Item			Model		1F1A18U/WU	P1F1A18JU/DU	P1F1A18U/WU	F1F1A18U
Lifting speed	2W lifting	Full load	mm/sec (FPM)	550 (108.3)	620 (122.0)	580 (114.2)	670 (131.9)	
		No load	mm/sec (FPM)	630 (124.0)	650 (127.9)	650 (127.9)	710 (139.8)	
	2F lifting	Full load	mm/sec (FPM)	530 (104.3)	550 (108.3)	530 (104.3)	600 (118.1)	
		No load	mm/sec (FPM)	570 (112.2)	590 (116.1)	590 (116.1)	640 (126.0)	
	3F lifting	Full load	mm/sec (FPM)	540 (106.3)	560 (110.2)	530 (104.3)	600 (118.1)	
		No load	mm/sec (FPM)	580 (114.2)	590 (116.1)	590 (116.1)	640 (126.0)	
Lowering speed	2W lifting	Full load	mm/sec (FPM)	500 (98.4)	500 (98.4)	500 (98.4)	500 (98.4)	
		No load	mm/sec (FPM)	500 (98.4)	500 (98.4)	500 (98.4)	500 (98.4)	
	2F lifting	Full load	mm/sec (FPM)	480 (94.5)	480 (94.5)	480 (94.5)	480 (94.5)	
		No load	mm/sec (FPM)	310 (61.0)	310 (61.0)	310 (61.0)	310 (61.0)	
	3F lifting	Full load	mm/sec (FPM)	480 (94.5)	480 (94.5)	480 (94.5)	480 (94.5)	
		No load	mm/sec (FPM)	370 (72.8)	370 (72.8)	370 (72.8)	370 (72.8)	
Travel speed	Forward	Full load	km/h (MPH)	19 (12)	19 (12)	19 (12)	19 (12)	
		No load	km/h (MPH)	19 (12)	19 (12)	19 (12)	19 (12)	
Drawbar pull	Full load (travel)		N (kg, lb)	12250 (1249, 2753)	16450 (1677, 3698)	15200 (1550, 3417)	14240 (1452, 3201)	
	No load		N (kg, lb)	11250 (1147, 2529)	11750 (1198, 2641)	11750 (1198, 2641)	11790 (1202, 2650)	
Gradeability	Full load (travel)		tanθ (%)	31	36	41	27	
	No load		tanθ (%)	24	24	24	21	
Truck weight (no load)	Single tire		kg (lb)	2835 (6251)	2835 (6251)	2835 (6251)	2890 (6372)	
	Double tire		kg (lb)	2940 (6483)	2940 (6483)	2940 (6483)	2995 (6604)	
ENGINE	Model			K15	K21	K21	S4Q2	
	Displacement		cm ³ (cu in)	1486 (90.68)	2065 (126.01)	2065 (126.01)	2505 (152.86)	
	Rated output		kW (HP)/rpm	26 (35)/2450	41 (55)/2700	34 (46)/2200	36 (48)/2500	
	Rated torque		N-m (ft-lb)/rpm	109 (80)/2000	151 (111)/2000	158 (117)/1600	149 (110)/2000	

1F2 series

Item		Model	P1F2A20JU/DU	P1F2A20U/WU	U1F2A20JU/DU	U1F2A20U/WU [U1F2M20U/WU]	Y1F2A20U [Y1F2M20U]
Load capacity		kg (lb)	2000 (4000)	2000 (4000)	2000 (4000)	2000 (4000)	2000 (4000)
Load center		mm (in)	500 (19.7)	500 (19.7)	500 (19.7)	500 (19.7)	500 (19.7)
Maximum fork height		mm (in)	3000 (118.1)	3000 (118.1)	3000 (118.1)	3000 (118.1)	3000 (118.1)
Free lift		mm (in)	155 (6.1)	155 (6.1)	155 (6.1)	155 (6.1)	155 (6.1)
Tilt angle	Forward	degree	6	6	6	6	6
	Backward	degree	12	12	12	12	12
Overall length (without fork length)		mm (in)	2220 (87.4)	2220 (87.4)	2220 (87.4)	2220 (87.4)	2220 (87.4)
Overall width	Single tire	mm (in)	1150 (45.3)	1150 (45.3)	1150 (45.3)	1150 (45.3)	1150 (45.3)
	Double tire	mm (in)	1640 (64.6)	1640 (64.6)	1640 (64.6)	1640 (64.6)	1640 (64.6)
Overall height	Mast (lowered)	mm (in)	1995 (78.5)	1995 (78.5)	1995 (78.5)	1995 (78.5)	1995 (78.5)
	Mast (extended) with backrest	mm (in)	4045 (159.3)	4045 (159.3)	4045 (159.3)	4045 (159.3)	4045 (159.3)
	Overhead guard	mm (in)	2115 (83.3)	2115 (83.3)	2115 (83.3)	2115 (83.3)	2115 (83.3)
Wheelbase		mm (in)	1600 (63.0)	1600 (63.0)	1600 (63.0)	1600 (63.0)	1600 (63.0)
Front overhang		mm (in)	455 (17.9)	455 (17.9)	455 (17.9)	455 (17.9)	455 (17.9)
Rear overhang		mm (in)	515 (20.3)	515 (20.3)	515 (20.3)	515 (20.3)	515 (20.3)
Front tread	Single tire	mm (in)	960 (37.8)	960 (37.8)	960 (37.8)	960 (37.8)	960 (37.8)
	Double tire	mm (in)	1205 (47.4)	1205 (47.4)	1205 (47.4)	1205 (47.4)	1205 (47.4)
Rear tread		mm (in)	975 (38.4)	975 (38.4)	975 (38.4)	975 (38.4)	975 (38.4)
Minimum turning radius	Outside	mm (in)	2145 (84.4)	2145 (84.4)	2145 (84.4)	2145 (84.4)	2145 (84.4)
Fork length (standard)		mm (in)	1070 (42.1)	1070 (42.1)	1070 (42.1)	1070 (42.1)	1070 (42.1)
Fork (width x thickness)		mm (in)	100 x 40 (3.9 x 1.6)	100 x 40 (3.9 x 1.6)	100 x 40 (3.9 x 1.6)	100 x 40 (3.9 x 1.6)	100 x 40 (3.9 x 1.6)
Ground clearance	Under mast	mm (in)	115 (4.5)	115 (4.5)	115 (4.5)	115 (4.5)	115 (4.5)
	Under power unit	mm (in)	135 (5.3)	135 (5.3)	135 (5.3)	135 (5.3)	135 (5.3)
	Under frame	mm (in)	155 (6.1)	155 (6.1)	155 (6.1)	155 (6.1)	155 (6.1)

1F2 series

Item			Model		P1F2A20JU/DU	P1F2A20U/WU	U1F2A20JU/DU	U1F2A20U/WU [U1F2M20U/WU]	Y1F2A20U [Y1F2M20U]
Lifting speed	2W lifting	Full load	mm/sec (FPM)	640 (126.0)	550 (108.3)	660 (129.9)	590 (116.1)	640 (126.0)	
		No load	mm/sec (FPM)	690 (135.8)	620 (122.0)	700 (137.8)	680 (133.8)	690 (135.8)	
	2F lifting	Full load	mm/sec (FPM)	600 (118.1)	520 (102.3)	620 (122.0)	550 (108.3)	600 (118.1)	
		No load	mm/sec (FPM)	650 (127.9)	580 (114.2)	670 (131.9)	640 (126.0)	650 (127.9)	
	3F lifting	Full load	mm/sec (FPM)	600 (118.1)	510 (100.4)	610 (120.1)	550 (108.3)	600 (118.1)	
		No load	mm/sec (FPM)	640 (126.0)	580 (114.2)	660 (129.9)	630 (124.0)	640 (126.0)	
Lowering speed	2W lifting	Full load	mm/sec (FPM)	500 (98.4)	500 (98.4)	500 (98.4)	500 (98.4)	500 (98.4)	
		No load	mm/sec (FPM)	500 (98.4)	500 (98.4)	500 (98.4)	500 (98.4)	500 (98.4)	
	2F lifting	Full load	mm/sec (FPM)	480 (94.5)	480 (94.5)	480 (94.5)	480 (94.5)	480 (94.5)	
		No load	mm/sec (FPM)	300 (59.0)	300 (59.0)	300 (59.0)	300 (59.0)	300 (59.0)	
	3F lifting	Full load	mm/sec (FPM)	480 (94.5)	480 (94.5)	480 (94.5)	480 (94.5)	480 (94.5)	
		No load	mm/sec (FPM)	330 (64.9)	330 (64.9)	330 (64.9)	330 (64.9)	330 (64.9)	
Travel speed	Forward	Full load	km/h (MPH)	19.5 (12.1)	19.5 (12.1)	19.5 (12.1)	19.5 (12.1)	19.5 (12.1)	
		No load	km/h (MPH)	19.5 (12.1)	19.5 (12.1)	19.5 (12.1)	19.5 (12.1)	19.5 (12.1)	
Drawbar pull	Full load (travel)		N (kg, lb)	17050 (1739, 3832)	15200 (1550, 3417)	18400 (1876, 4136)	17250 (1759, 3877) [17950 (1830, 4035)]	20700 (2111, 4653)	
	No load		N (kg, lb)	15300 (1560, 3439)	15300 (1560, 3439)	15300 (1560, 3439)	15300 (1560, 3439)	16050 (1637, 3608)	
Gradeability	Full load (travel)		tanθ (%)	32	33	35	39	36	
	No load		tanθ (%)	28	28	28	28	28	
Truck weight (no load)	Single tire		kg (lb)	3365 (7420)	3365 (7420)	3365 (7420)	3365 (7420)	3490 (7695)	
	Double tire		kg (lb)	3460 (7629)	3460 (7629)	3460 (7629)	3460 (7629)	3585 (7905)	
ENGINE	Model			K21	K21	K25	K25	QD32	
	Displacement		cm ³ (cu in)	2065 (126.01)	2065 (126.01)	2488 (151.82)	2488 (151.82)	3153 (192.40)	
	Rated output		kW (HP)/rpm	41 (55)/2700	34 (46)/2200	46.9 (63)/2700	40 (54)/2200	38 (51)/2000	
	Rated torque		N·m (ft·lb)/rpm	151 (111)/2000	158 (117)/1600	188 (139)/2000	186 (137)/1600	186 (137)/1800	

1F2 series

Item		Model	P1F2A25JU/DU	P1F2A25U/WU	U1F2A25JU/DU	U1F2A25U/WU [U1F2M25U/WU]	Y1F2A25U [Y1F2M25U]
Load capacity		kg (lb)	2500 (5000)	2500 (5000)	2500 (5000)	2500 (5000)	2500 (5000)
Load center		mm (in)	500 (19.7)	500 (19.7)	500 (19.7)	500 (19.7)	500 (19.7)
Maximum fork height		mm (in)	3000 (118.1)	3000 (118.1)	3000 (118.1)	3000 (118.1)	3000 (118.1)
Free lift		mm (in)	155 (6.1)	155 (6.1)	155 (6.1)	155 (6.1)	155 (6.1)
Tilt angle	Forward	degree	6	6	6	6	6
	Backward	degree	12	12	12	12	12
Overall length (without fork length)		mm (in)	2220 (87.4)	2220 (87.4)	2220 (87.4)	2220 (87.4)	2220 (87.4)
Overall width	Single tire	mm (in)	1150 (45.3)	1150 (45.3)	1150 (45.3)	1150 (45.3)	1150 (45.3)
	Double tire	mm (in)	1640 (64.6)	1640 (64.6)	1640 (64.6)	1640 (64.6)	1640 (64.6)
Overall height	Mast (lowered)	mm (in)	1995 (78.5)	1995 (78.5)	1995 (78.5)	1995 (78.5)	1995 (78.5)
	Mast (extended) with backrest	mm (in)	4045 (159.3)	4045 (159.3)	4045 (159.3)	4045 (159.3)	4045 (159.3)
	Overhead guard	mm (in)	2115 (83.3)	2115 (83.3)	2115 (83.3)	2115 (83.3)	2115 (83.3)
Wheelbase		mm (in)	1600 (63.0)	1600 (63.0)	1600 (63.0)	1600 (63.0)	1600 (63.0)
Front overhang		mm (in)	455 (17.9)	455 (17.9)	455 (17.9)	455 (17.9)	455 (17.9)
Rear overhang		mm (in)	515 (20.3)	515 (20.3)	515 (20.3)	515 (20.3)	515 (20.3)
Front tread	Single tire	mm (in)	960 (37.8)	960 (37.8)	960 (37.8)	960 (37.8)	960 (37.8)
	Double tire	mm (in)	1205 (47.4)	1205 (47.4)	1205 (47.4)	1205 (47.4)	1205 (47.4)
Rear tread		mm (in)	975 (38.4)	975 (38.4)	975 (38.4)	975 (38.4)	975 (38.4)
Minimum turning radius	Outside	mm (in)	2230 (87.8)	2230 (87.8)	2230 (87.8)	2230 (87.8)	2230 (87.8)
Fork length (standard)		mm (in)	1070 (42.1)	1070 (42.1)	1070 (42.1)	1070 (42.1)	1070 (42.1)
Fork (width x thickness)		mm (in)	100 x 40 (3.9 x 1.6)	100 x 40 (3.9 x 1.6)	100 x 40 (3.9 x 1.6)	100 x 40 (3.9 x 1.6)	100 x 40 (3.9 x 1.6)
Ground clearance	Under mast	mm (in)	115 (4.5)	115 (4.5)	115 (4.5)	115 (4.5)	115 (4.5)
	Under power unit	mm (in)	135 (5.3)	135 (5.3)	135 (5.3)	135 (5.3)	135 (5.3)
	Under frame	mm (in)	155 (6.1)	155 (6.1)	155 (6.1)	155 (6.1)	155 (6.1)

1F2 series

Item			Model		P1F2A25JU/DU	P1F2A25U/WU	U1F2A25JU/DU	U1F2A25U/WU [U1F2M25U/WU]	Y1F2A25U [Y1F2M25U]
Lifting speed	2W lifting	Full load	mm/sec (FPM)	660 (129.9)	550 (108.3)	660 (129.9)	590 (116.1)	640 (126.0)	
		No load	mm/sec (FPM)	700 (137.8)	620 (122.0)	700 (137.8)	680 (133.8)	690 (135.8)	
	2F lifting	Full load	mm/sec (FPM)	620 (122.0)	520 (102.3)	620 (122.0)	550 (108.3)	600 (118.1)	
		No load	mm/sec (FPM)	670 (131.9)	580 (114.2)	670 (131.9)	640 (126.0)	650 (127.9)	
	3F lifting	Full load	mm/sec (FPM)	610 (120.1)	510 (100.4)	610 (120.1)	550 (108.3)	600 (118.1)	
		No load	mm/sec (FPM)	660 (129.9)	580 (114.2)	660 (129.9)	630 (124.0)	640 (126.0)	
Lowering speed	2W lifting	Full load	mm/sec (FPM)	500 (98.4)	500 (98.4)	500 (98.4)	500 (98.4)	500 (98.4)	
		No load	mm/sec (FPM)	500 (98.4)	500 (98.4)	500 (98.4)	500 (98.4)	500 (98.4)	
	2F lifting	Full load	mm/sec (FPM)	480 (94.5)	480 (94.5)	480 (94.5)	480 (94.5)	480 (94.5)	
		No load	mm/sec (FPM)	300 (59.0)	300 (59.0)	300 (59.0)	300 (59.0)	300 (59.0)	
	3F lifting	Full load	mm/sec (FPM)	480 (94.5)	480 (94.5)	480 (94.5)	480 (94.5)	480 (94.5)	
		No load	mm/sec (FPM)	330 (64.9)	330 (64.9)	330 (64.9)	330 (64.9)	330 (64.9)	
Travel speed	Forward	Full load	km/h (MPH)	19.5 (12.1)	19.5 (12.1)	19.5 (12.1)	19.5 (12.1)	19.5 (12.1)	
		No load	km/h (MPH)	19.5 (12.1)	19.5 (12.1)	19.5 (12.1)	19.5 (12.1)	19.5 (12.1)	
Drawbar pull	Full load (travel)		N (kg, lb)	17050 (1739, 3832)	15200 (1550, 3417)	18400 (1876, 4136)	17250 (1759, 3877) [16750 (1708, 3765)]	20700 (2111, 4653) [16410 (1673, 3689)]	
	No load		N (kg, lb)	15300 (1560, 3439)	15300 (1560, 3439)	15300 (1560, 3439)	15300 (1560, 3439)	10100 (1030, 2270) [13860 (1413, 3115)]	
Gradeability	Full load (travel)		tanθ (%)	26	28	29	31	33	
	No load		tanθ (%)	23	24	23	24	23	
Truck weight (no load)	Single tire		kg (lb)	3730 (8225)	3730 (8225)	3730 (8225)	3730 (8225)	3850 (8489)	
	Double tire		kg (lb)	3825 (8434)	3825 (8434)	3825 (8434)	3825 (8434)	3945 (8699)	
ENGINE	Model			K21	K21	K25	K25	QD32	
	Displacement		cm ³ (cu in)	2065 (126.01)	2065 (126.01)	2488 (151.82)	2488 (151.82)	3153 (192.40)	
	Rated output		kW (HP)/rpm	41 (55)/2700	34 (46)/2200	46.9 (63)/2700	40 (54)/2200	38 (51)/2000	
	Rated torque		N·m (ft·lb)/rpm	151 (111)/2000	158 (117)/1600	188 (139)/2000	186 (137)/1600	186 (137)/1800	

1F2 series

Item		Model	UG1F2A30JU/DU	UG1F2A30U/WU	YG1F2A30U [YG1F2M30U]
Load capacity		kg (lb)	3000 (6000)	3000 (6000)	3000 (6000)
Load center		mm (in)	500 (19.7)	500 (19.7)	500 (19.7)
Maximum fork height		mm (in)	3000 (118.1)	3000 (118.1)	3000 (118.1)
Free lift		mm (in)	155 (6.1)	155 (6.1)	155 (6.1)
Tilt angle	Forward	degree	6	6	6
	Backward	degree	12	12	12
Overall length (without fork length)		mm (in)	2320 (91.3)	2320 (91.3)	2320 (91.3)
Overall width	Single tire	mm (in)	1250 (49.2)	1250 (49.2)	1250 (49.2)
	Double tire	mm (in)	1665 (65.6)	1665 (65.6)	1665 (65.6)
Overall height	Mast (lowered)	mm (in)	1995 (78.5)	1995 (78.5)	1995 (78.5)
	Mast (extended) with backrest	mm (in)	4140 (163.0)	4140 (163.0)	4140 (163.0)
	Overhead guard	mm (in)	2150 (84.6)	2150 (84.6)	2150 (84.6)
Wheelbase		mm (in)	1770 (66.9)	1770 (66.9)	1770 (66.9)
Front overhang		mm (in)	485 (19.1)	485 (19.1)	485 (19.1)
Rear overhang		mm (in)	530 (20.9)	530 (20.9)	530 (20.9)
Front tread	Single tire	mm (in)	1030 (40.6)	1030 (40.6)	1030 (40.6)
	Double tire	mm (in)	1210 (47.6)	1210 (47.6)	1210 (47.6)
Rear tread		mm (in)	980 (38.6)	980 (38.6)	980 (38.6)
Minimum turning radius	Outside	mm (in)	2330 (91.7)	2330 (91.7)	2330 (91.7)
Fork length (standard)		mm (in)	1070 (42.1)	1070 (42.1)	1070 (42.1)
Fork (width x thickness)		mm (in)	122 x 45 (4.8 x 1.8)	122 x 45 (4.8 x 1.8)	122 x 45 (4.8 x 1.8)
Ground clearance	Under mast	mm (in)	145 (5.7)	145 (5.7)	145 (5.7)
	Under power unit	mm (in)	165 (6.5)	165 (6.5)	165 (6.5)
	Under frame	mm (in)	185 (7.3)	185 (7.3)	185 (7.3)

1F2 series

Item		Model		UG1F2A30JU/DU	UG1F2A30U/WU	YG1F2A30U [YG1F2M30U]
Lifting speed	2W lifting	Full load	mm/sec (FPM)	530 (104.3)	500 (98.4)	540 (106.3)
		No load	mm/sec (FPM)	560 (110.2)	550 (108.3)	580 (114.2)
	2F lifting	Full load	mm/sec (FPM)	520 (102.3)	490 (96.4)	530 (104.3)
		No load	mm/sec (FPM)	550 (108.3)	540 (106.3)	570 (112.2)
	3F lifting	Full load	mm/sec (FPM)	510 (100.4)	480 (94.5)	520 (102.3)
		No load	mm/sec (FPM)	540 (106.3)	530 (104.3)	560 (110.2)
Lowering speed	2W lifting	Full load	mm/sec (FPM)	500 (98.4)	500 (98.4)	500 (98.4)
		No load	mm/sec (FPM)	500 (98.4)	500 (98.4)	500 (98.4)
	2F lifting	Full load	mm/sec (FPM)	470 (92.5)	470 (92.5)	470 (92.5)
		No load	mm/sec (FPM)	320 (63.1)	320 (63.1)	320 (63.1)
	3F lifting	Full load	mm/sec (FPM)	470 (92.5)	470 (92.5)	470 (92.5)
		No load	mm/sec (FPM)	360 (70.8)	360 (70.8)	360 (70.8)
Travel speed	Forward	Full load	km/h (MPH)	19.5 (12.1)	19.5 (12.1)	19 (12)
		No load	km/h (MPH)	19.5 (12.1)	19.5 (12.1)	19 (12)
Drawbar pull	Full load (travel)		N (kg, lb)	18200 (1856, 4091)	17000 (1734, 3821)	21670 (2210, 4871) [17480 (1783, 3929)]
	No load		N (kg, lb)	11800 (1203, 2652)	18500 (1887, 4158)	11800 (1203, 2652)
Gradeability	Full load (travel)		tanθ (%)	24	27	29
	No load		tanθ (%)	24	24	23
Truck weight (no load)	Single tire		kg (lb)	4280 (9437)	4280 (9437)	4400 (9702)
	Double tire		kg (lb)	4390 (9680)	4390 (9680)	4510 (9945)
ENGINE	Model			K25	K25	QD32
	Displacement		cm ³ (cu in)	2488 (151.82)	2488 (151.82)	3153 (192.40)
	Rated output		kW (HP)/rpm	46.9 (63)/2700	40 (54)/2200	38 (51)/2000
	Rated torque		N·m (ft·lb)/rpm	188 (139)/2000	186 (137)/1600	186 (137)/1800

1F2 series

Item		Model	UG1F2A35JU/DU	UG1F2A35U/WU	YG1F2A35U [YG1F2M35U]
Load capacity		kg (lb)	3500 (7000)	3500 (7000)	3500 (7000)
Load center		mm (in)	500 (19.7)	500 (19.7)	500 (19.7)
Maximum fork height		mm (in)	3000 (118.1)	3000 (118.1)	3000 (118.1)
Free lift		mm (in)	155 (6.1)	155 (6.1)	155 (6.1)
Tilt angle	Forward	degree	6	6	6
	Backward	degree	12	12	12
Overall length (without fork length)		mm (in)	2350 (92.5)	2350 (92.5)	2350 (92.5)
Overall width	Single tire	mm (in)	1280 (50.4)	1280 (50.4)	1280 (50.4)
	Double tire	mm (in)	1720 (67.7)	1720 (67.7)	1720 (67.7)
Overall height	Mast (lowered)	mm (in)	1995 (78.5)	1995 (78.5)	1995 (78.5)
	Mast (extended) with backrest	mm (in)	4140 (163.0)	4140 (163.0)	4140 (163.0)
	Overhead guard	mm (in)	2155 (84.8)	2155 (84.8)	2155 (84.8)
Wheelbase		mm (in)	1770 (66.9)	1770 (66.9)	1770 (66.9)
Front overhang		mm (in)	485 (19.1)	485 (19.1)	485 (19.1)
Rear overhang		mm (in)	595 (23.4)	595 (23.4)	595 (23.4)
Front tread	Single tire	mm (in)	1060 (41.7)	1060 (41.7)	1060 (41.7)
	Double tire	mm (in)	1230 (48.4)	1230 (48.4)	1230 (48.4)
Rear tread		mm (in)	980 (38.6)	980 (38.6)	980 (38.6)
Minimum turning radius	Outside	mm (in)	2420 (95.3)	2420 (95.3)	2420 (95.3)
Fork length (standard)		mm (in)	1070 (42.1)	1070 (42.1)	1070 (42.1)
Fork (width x thickness)		mm (in)	122 x 45 (4.8 x 1.8)	122 x 45 (4.8 x 1.8)	122 x 45 (4.8 x 1.8)
Ground clearance	Under mast	mm (in)	155 (6.1)	155 (6.1)	155 (6.1)
	Under power unit	mm (in)	170 (6.7)	170 (6.7)	170 (6.7)
	Under frame	mm (in)	190 (7.5)	190 (7.5)	190 (7.5)

1F2 series

Item		Model		UG1F2A35JU/DU	UG1F2A35U/WU	YG1F2A35U [YG1F2M35U]
Lifting speed	2W lifting	Full load	mm/sec (FPM)	450 (88.6)	400 (78.7)	440 (86.6)
		No load	mm/sec (FPM)	470 (92.5)	460 (90.5)	480 (94.5)
	2F lifting	Full load	mm/sec (FPM)	420 (82.7)	370 (72.8)	410 (80.7)
		No load	mm/sec (FPM)	440 (86.6)	430 (84.6)	450 (88.6)
	3F lifting	Full load	mm/sec (FPM)	420 (82.7)	370 (72.8)	410 (80.7)
		No load	mm/sec (FPM)	440 (86.6)	430 (84.6)	450 (88.6)
Lowering speed	2W lifting	Full load	mm/sec (FPM)	420 (82.7)	420 (82.7)	420 (82.7)
		No load	mm/sec (FPM)	360 (70.8)	360 (70.8)	360 (70.8)
	2F lifting	Full load	mm/sec (FPM)	390 (76.7)	390 (76.7)	390 (76.7)
		No load	mm/sec (FPM)	300 (59.0)	300 (59.0)	300 (59.0)
	3F lifting	Full load	mm/sec (FPM)	390 (76.7)	390 (76.7)	390 (76.7)
		No load	mm/sec (FPM)	300 (59.0)	300 (59.0)	300 (59.0)
Travel speed	Forward	Full load	km/h (MPH)	19 (12)	19 (12)	19 (12) [18 (11)]
		No load	km/h (MPH)	19 (12)	19 (12)	19 (12) [18 (11)]
Drawbar pull	Full load (travel)		N (kg, lb)	17300 (1764, 3889)	15700 (1601, 3529)	21670 (2210, 4871) [17480 (1783, 3929)]
	No load		N (kg, lb)	11700 (1193, 2630)	17650 (1800, 3967)	11800 (1203, 2652)
Gradeability	Full load (travel)		tanθ (%)	20	23	25
	No load		tanθ (%)	22	22	22
Truck weight (no load)	Single tire		kg (lb)	4605 (10154)	4605 (10154)	4730 (10430)
	Double tire		kg (lb)	4735 (10441)	4735 (10441)	4860 (10716)
ENGINE	Model			K25	K25	QD32
	Displacement		cm ³ (cu in)	2488 (151.82)	2488 (151.82)	3153 (192.40)
	Rated output		kW (HP)/rpm	46.9 (63)/2700	40 (54)/2200	38 (51)/2000
	Rated torque		N·m (ft·lb)/rpm	188 (139)/2000	186 (137)/1600	186 (137)/1800

A1F1/2 series

Item		Model	AP1F1A16JU/DU	AP1F2A25JU/DU
Load capacity		kg (lb)	1600 (3200)	2500 (5000)
Load center		mm (in)	500 (19.7)	500 (19.7)
Maximum fork height		mm (in)	3000 (118.1)	3000 (118.1)
Free lift		mm (in)	155 (6.1)	105 (4.1)
Tilt angle	Forward	degree	5	5
	Backward	degree	10	10
Overall length (without fork length)		mm (in)	2105 (82.9)	2245 (88.4)
Overall width		mm (in)	1035 (40.7)	1175 (46.3)
Overall height	Single tire	mm (in)	1990 (78.3)	1955 (77.0)
	Mast (lowered)	mm (in)	1990 (78.3)	1955 (77.0)
	Mast (extended) with backrest	mm (in)	3960 (155.9)	3960 (155.9)
Overhead guard		mm (in)	2105 (82.9)	2090 (82.3)
Wheelbase		mm (in)	1290 (50.8)	1500 (59.1)
Front overhang		mm (in)	390 (15.4)	425 (16.7)
Rear overhang		mm (in)	460 (18.1)	430 (16.9)
Front tread		mm (in)	870 (34.3)	975 (38.4)
Rear tread		mm (in)	885 (34.8)	930 (36.6)
Minimum turning radius		mm (in)	1850 (72.8)	2030 (79.9)
Fork length (standard)		mm (in)	1070 (42.1)	1070 (42.1)
Fork (width x thickness)		mm (in)	100 x 35 (3.9 x 1.4)	100 x 40 (3.9 x 1.6)
Ground clearance	Under mast	mm (in)	110 (4.3)	75 (3.0)
	Under power unit	mm (in)	95 (3.7)	65 (2.6)
	Under frame	mm (in)	140 (5.5)	130 (5.1)

A1F1/2 series

Item			Model		AP1F1A16JU/DU	AP1F2A25JU/DU
Lifting speed	2W lifting	Full load	mm/sec (FPM)	600 (118.1)	620 (122.0)	
		No load	mm/sec (FPM)	630 (124.0)	650 (127.9)	
	2F lifting	Full load	mm/sec (FPM)	530 (104.3)	560 (110.2)	
		No load	mm/sec (FPM)	570 (112.2)	620 (122.0)	
	3F lifting	Full load	mm/sec (FPM)	540 (106.3)	560 (110.2)	
		No load	mm/sec (FPM)	580 (114.2)	610 (120.1)	
Lowering speed	2W lifting	Full load	mm/sec (FPM)	500 (98.4)	500 (98.4)	
		No load	mm/sec (FPM)	500 (98.4)	500 (98.4)	
	2F lifting	Full load	mm/sec (FPM)	480 (94.5)	480 (94.5)	
		No load	mm/sec (FPM)	310 (61.0)	300 (59.0)	
	3F lifting	Full load	mm/sec (FPM)	480 (94.5)	480 (94.5)	
		No load	mm/sec (FPM)	370 (72.8)	330 (64.9)	
Travel speed	Forward	Full load	km/h (MPH)	17 (11)	17 (11)	
		No load	km/h (MPH)	17 (11)	17 (11)	
Drawbar pull	Full load (travel)		N (kg, lb)	16400 (1672, 3686)	16670 (1700, 3747)	
	No load		N (kg, lb)	10590 (1080, 2380)	9710 (990, 2182)	
Gradeability	Full load (travel)		tanθ (%)	39	27	
	No load		tanθ (%)	28	21	
Truck weight (no load)	Single tire		kg (lb)	2660 (5865)	3525 (7773)	
ENGINE	Model			K21	K21	
	Displacement		cm ³ (cu in)	2065 (126.01)	2065 (126.01)	
	Rated output		kW (HP)/rpm	41 (55)/2700	41 (55)/2700	
	Rated torque		N·m (ft·lb)/rpm	151 (111)/2000	151 (111)/2000	

NOISE LEVEL

The values are the A-weighted sound pressure level at the operator's position, L_{PAZ} and the uncertainty value, K_{PZ} according to EN12053: 2001.

Item \ Model	A1F1, A1F2	G1F2
L_{PAZ}	80 dB (A)	79 dB (A)
K_{PZ}	4 dB (A)	4 dB (A)

The whole body vibration $\bar{a}_{w,z}$ according to EN13059:2002

Vibration emission value: 1.0 m/s²

Uncertainty: 0.3 m/s²

NOTE:

Higher or lower noises can occur due to other noise sources and individual conditions such as operation mode, environment tire, or floor.

FUEL & OIL CAPACITY

Model			1F1 series compact vehicle			1F1 series			1F2 series compact vehicle			1F2 series					
			2.0, 2.5 ton (4000, 5000 lb)			2.75, 3.0, 3.5 ton (5500, 6000, 7000 lb)											
Item			ℓ	Imp	US	ℓ	Imp	US	ℓ	Imp	US	ℓ	Imp	US	ℓ	Imp	US
Fuel tank			42.0	9-1/4 gal	11-1/8 gal	47.6	10-1/2 gal	12-5/8 gal	58.0	12-3/4 gal	15-3/8 gal	66.7	14-5/8 gal	17-5/8 gal	72.1	15-7/8 gal	19 gal
Hydraulic oil tank			28.2	6-1/4 gal	7-1/2 gal	30	6-5/8 gal	7-7/8 gal	39.2	8-5/8 gal	10-3/8 gal	44.6	9-7/8 gal	11-3/4 gal	49.1	10-3/4 gal	13 gal
Transmission oil	Pneumatic tire model	1-speed	9.0	7-7/8 qt	9-1/2 qt	10.4	9-1/8 qt	11 qt	9.0	7-7/8 qt	9-1/2 qt	10.4	9-1/8 qt	11 qt	10.4	9-1/8 qt	11 qt
Differential oil			2.9	2-1/2 qt	3-1/8 qt	4.9	4-3/8 qt	5-1/8 qt	2.9	2-1/2 qt	3-1/8 qt	6.3	5-1/2 qt	6-5/8 qt	9.0	7-7/8 qt	9-1/2 qt

*1: Including differential oil

BULBS

Item	Wattage (W)	
Headlamp (QD32 dust proofing specification)	55 (27)	
Rear combination lamp	Stop/Tail	21/5
	Turn signal	21
	Back-up	21
Front turn signal lamp	23	
PATO lamp	35	
OPE lamp	55	

ENGINE

Item \ Model	K15		K21		K25		S4Q2		QD32			
Type	Gasoline						Diesel					
Cylinder arrangement	4-cylinder, in-line											
Valve mechanism	Overhead valve type											
Bore x Stroke	mm (in)		75.5 x 83.0 (2.972 x 3.268)		89.0 x 83.0 (3.504 x 3.268)		89.0 x 100 (3.504 x 3.937)		88.0 x 103 (3.46 x 4.06)		99.2 x 102 (3.9 x 4.0)	
Total displacement	cm ³ (cu in)		1486 (90.68)		2065 (126.01)		2488 (151.82)		2505 (152.86)		3153 (192.40)	
Compression ratio	9.0		8.7		8.7		22		22			
Firing order	1-3-4-2											

ENGINE OIL CAPACITY

Item \ Model	K15			K21			K25			S4Q2			QD32		
	ℓ	Imp qt	US qt	ℓ	Imp qt	US qt	ℓ	Imp qt	US qt	ℓ	Imp qt	US qt	ℓ	Imp qt	US qt
Engine oil (with oil filter)	3.7	3-1/4	3-7/8	3.8	3-3/8	4	3.8	3-3/8	4	8.5	7-1/2	9	7.2	6-3/8	7-5/8

Index

B

Battery	
Jump starting procedure	78
Brake	
Inching brake pedal	45
Parking brake lever	44
Bulbs	154

C

Chassis and body	98
Chassis serial number	128
Climbing	59

D

Daily care and inspection	80
Diesel engine	49

E

Engine	155
Diesel engine	49

F

Forks	60
Fuel	
Fuel & oil capacity	154
Fuel filter	97

I

Identification numbers	129
Inching brake pedal	45
Instruments and controls	20

L

Lifting up forklift	62
Load chart	127
Load control levers	54
Loading	61
Lubrication chart	107

M

Maintenance	91
Mirror	
Rearview mirror	75

N

Name of components	5
--------------------------	---

O

Oil	
Engine oil capacity	155
Fuel & oil capacity	154

P

Parking	
Parking brake lever	44, 53, 99
Stopping and parking	60
Periodic maintenance schedule	102, 125
Precautions for cold and hot weather	76
Precautions for using the LPG model	111

R

Rearview mirror	75
Recommended lubricants	96
Recommended SAE viscosity number	97

S

Seat adjustment	65, 68
Specifications	139
Starting	
Starting and operating	47
Steering	
Steering wheel	74, 89
Stopping and parking	60
Switch	
Switches and controls	37

T

Traction bar	64
Transportation	61
Traveling	59

Truck modification	3
Turning	59

U

Unloading	61
-----------------	----

MEMO

MEMO

Printing: September 2015
Printed in Japan



UNI CARRIERS
UniCarriers Corporation