



www.conairgroup.com

USERGUIDE
UGH014/0100

Thermolator[®] TW Series

Water Temperature Control Unit



Please record your equipment's model and serial number(s) and the date you received it in the spaces provided.

It's a good idea to record the model and serial number(s) of your equipment and the date you received it in the User Guide. Our service department uses this information, along with the manual number, to provide help for the specific equipment you installed.

Please keep this User Guide and all manuals, engineering prints and parts lists together for documentation of your equipment.

Date:
Manual Number: UGH014/0100
Serial number(s):
Model number(s):

DISCLAIMER: The Conair Group, Inc., shall not be liable for errors contained in this User Guide or for incidental, consequential damages in connection with the furnishing, performance or use of this information. Conair makes no warranty of any kind with regard to this information, including, but not limited to the implied warranties of merchantability and fitness for a particular purpose.

TABLE OF CONTENTS

INTRODUCTION	1-1
Purpose of the User Guide	1-2
How the guide is organized	1-2
Your responsibility as a user	1-2
ATTENTION: Read this so no one gets hurt	1-3
DESCRIPTION	2-1
What is the Thermolator TW?	2-2
Typical applications	2-2
How it works	2-3
Specifications	2-4
Features and options	2-5
INSTALLATION	3-1
Unpacking the boxes	3-2
Preparing for installation	3-3
Connecting the water supply	3-4
Optional purge valve hookups	3-5
Connecting the main power	3-6
Testing the installation	3-7
Initial setup	3-8
Changing temperature units	3-9
Setting SPI communication	3-10
Setting the security level	3-12
OPERATION	4-1
TW control features	4-2
The menu system	4-3
Starting the Thermolator	4-4
Stopping the Thermolator	4-5
Using the manual purge option	4-8
MAINTENANCE	5-1
Preventative maintenance schedule	5-2
Accessing the Thermolator enclosure	5-3
Performing an Autotune	5-4
TROUBLESHOOTING	6-1
Before beginning	6-2
A few words of caution	6-2
How to identify the cause of a problem	6-3
<i>Diagnostics</i>	
Controller alarms	6-4
Mechanical/electrical problems	6-10
Unit will not power up	6-12

TABLE OF CONTENTS

TROUBLESHOOTING (CONTINUED)6-1

Repair

Resetting overloads	6-13
Replacing the pump overload	6-13
Replacing the temperature controller	6-14
Replacing the heater contactor	6-15
Checking the thermocouple	6-16
Replacing the thermocouple	6-17
Repairing solenoid valves	6-18
Replacing heater elements	6-20
Removing the pump	6-22
Disassembling and assembling 3/4 to 2 Hp pumps	6-23
Dissassembling and assembling 3 to 7.5 Hp pumps	6-24

APPENDIX

Customer Service Information	A-1
Warranty Guarantee Information	A-2
Default Paramaters	B-1
Technical Information: Plumbing diagram	C-1
Technical Information: Pump Curves	C-2
Material Safety Data Sheets	D-1
Series 16 Temperature Controller Instruction Manual	

(included in binder pocket or instruction packet)

Additional manuals or information may be included in the appendix or instruction packet depending on the options installed on the unit.

PARTS/DIAGRAMS

Parts list	PD-1
TW wiring schematic	PD-5

INTRODUCTION

- *Purpose of the User Guide1-2*
- *How the guide is organized1-2*
- *Your responsibilities as a user .1-2*
- *ATTENTION: Read this so
no one gets hurt1-3*





PURPOSE OF THE USER GUIDE

This User Guide describes the Conair Thermolator® TW water temperature control units and explains step-by-step how to install, operate, maintain and repair this equipment.

Before installing this product, please take a few moments to read the User Guide and review the diagrams and safety information in the instruction packet. You also should review manuals covering associated equipment in your system. This review won't take long, and it could save you valuable installation and operating time later.

HOW THE GUIDE IS ORGANIZED

Symbols have been used to help organize the User Guide and call your attention to important information regarding safe installation and operation.

-  Symbols within triangles warn of conditions that could be hazardous to users or could damage equipment. Read and take precautions before proceeding.
-  Numbers within shaded squares indicate tasks or steps to be performed by the user.
-  A diamond indicates the equipment's response to an action performed by the user.
-  An open box marks items in a checklist.
-  A shaded circle marks items in a list.

YOUR RESPONSIBILITY AS A USER

You must be familiar with all safety procedures concerning installation, operation and maintenance of this equipment. Responsible safety procedures include:

- Thorough review of this User Guide, paying particular attention to hazard warnings, appendices and related diagrams.
- Thorough review of the equipment itself, with careful attention to voltage requirements, intended uses and warning labels.
- Thorough review of instruction manuals for associated equipment.
- Step-by-step adherence to instructions outlined in this User Guide.

We design equipment with the user's safety in mind. You can avoid the potential hazards identified on this machine by following the procedures outlined below and elsewhere in the User Guide.

 **ATTENTION:
READ THIS SO NO
ONE GETS HURT**



WARNING: Improper installation, operation or servicing may result in equipment damage or personal injury.

This equipment should be installed, adjusted, and serviced by qualified technical personnel who are familiar with the construction, operation and potential hazards of this type of equipment.

All wiring, disconnects and fuses should be installed by qualified electrical technicians in accordance with electrical codes in your region.

Always maintain a safe ground. A properly sized conductive ground wire from the incoming power supply must be connected to the chassis ground terminal inside the electrical enclosure. Improper grounding can result in personal injury and erratic machine operation.

Do not operate the equipment at power levels other than what is specified on the the equipment serial tag and data plate.



WARNING: Electrical shock hazard

This equipment is powered by three-phase main voltage, as specified on the machine serial tag and data plate.

Always disconnect and lock out the incoming main power source before opening the electrical enclosure or performing non-standard operating procedures, such as troubleshooting or maintenance. Only qualified personnel should perform procedures that require access to the electrical enclosure while power is on.



CAUTION: Hot surfaces

Surface temperatures inside the Thermolator can exceed 250° F (121° C). Always allow the unit to cool to below 100° F (38° C) before opening, servicing or disassembling the unit.

 **ATTENTION:**
READ THIS SO NO
ONE GETS HURT



WARNING: Hazardous substance

The electrical contactors in the Thermolator have mercury contactors. Mercury is considered a hazardous substance and must be dealt with accordingly. Material Safety Data Sheet (#7439-97) has been included in the instruction packet. This sheet explains the potential hazards, how to avoid them and how to clean up and dispose of the mercury if it spills.

DESCRIPTION

- *What is the Thermolator TW?* . . .2-2
- *Typical applications*2-2
- *How it works:*2-3
- *Specifications*2-4
- *Features and options*2-5

WHAT IS THE THERMOLATOR TW?

The Thermolator TW models circulate water at a temperature higher than the available water supply, to add or remove heat as needed to maintain a uniform temperature setpoint in the process.

The TW is available in single or multiple-zone configurations, using direct injection process heating and cooling. Multiple-zone models can control up to three temperatures at different locations in the process. Two- and three-zone models have common cooling water manifolds and electrical connections.

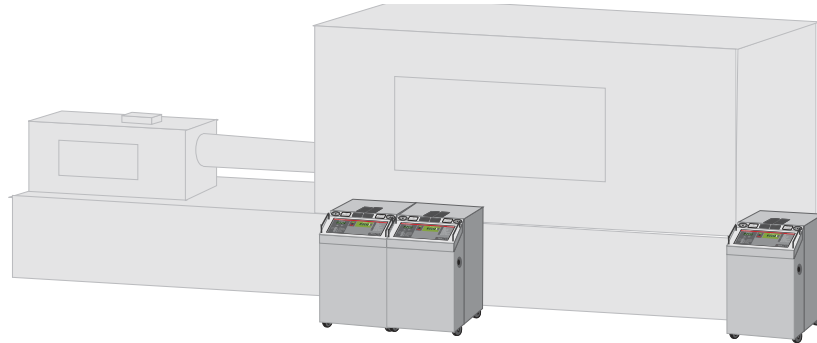

TYPICAL APPLICATIONS

The best model for your application depends on the process temperature you need to maintain and the quality of the cooling water supply.

TW direct injection (DI) models control the temperature by discharging heated process water and adding cooling water directly from the water supply. DI models are designed for:

- Process temperatures up to 250°F (121°C).
- Use with chiller water or properly treated and filtered tower or city water.

Direct injection models may be used with glycol/water process loop mixtures, as long as the glycol does not exceed 25% of the mixture. If your application requires a higher percentage of glycol, or you have a contaminated cooling water supply, ask your Conair representative about our closed-circuit or isolated circuit Thermolator TW-1 and TW-2 models.

IMPORTANT: Do not use deionized water or glycol mixtures containing additives in a Thermolator. Softened water or glycol mixtures with additives, such as automotive fluids, can damage the Thermolator. Glycol/water process loop mixtures should use only industrial-grade ethylene glycol.

Direct injection models maintain the process temperature by electrically heating and injecting cool water supplied to the Thermolator by a chiller, tower or other water source.

HOW IT WORKS: DIRECT INJECTION

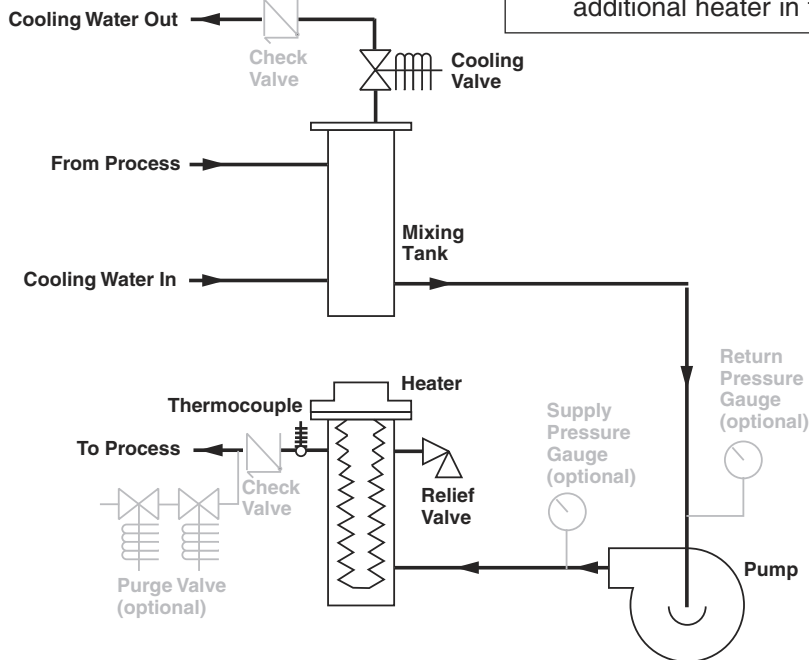
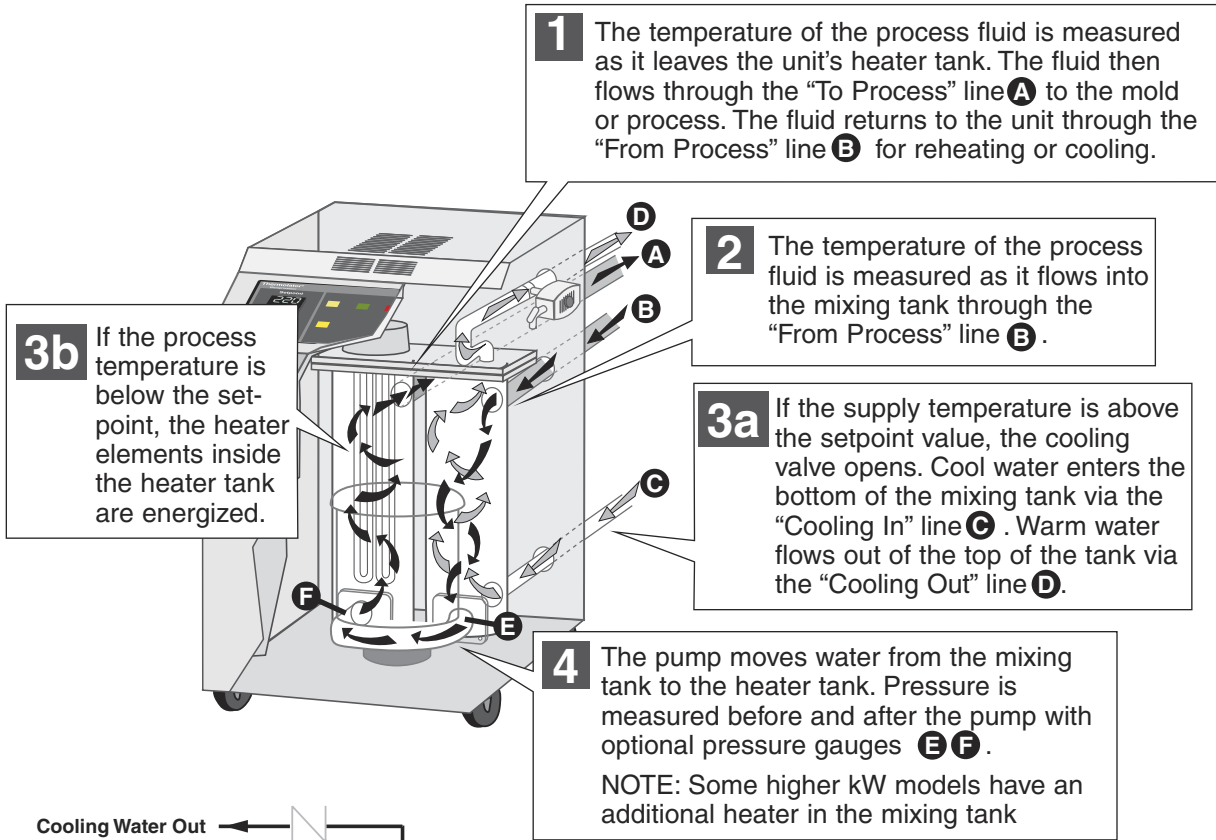

TW Direct Injection

Check valves included only with optional mold purge.

SPECIFICATIONS

Dimensions and performance characteristics vary according to the model, voltage and components selected. See the cabinet style reference chart to determine dimensional information for your specific model. Additional technical information can be found in the Appendix of this User Guide.

CABINET STYLE REFERENCE				
Heater	Voltage Selection	Single Zone	2 Zone	3 Zone
Direct Injection (DI)				
9, 12, 18 or 24 kW	208, 230, 460, 575	A	B	C
36 kW	460 or 575	A	B	C

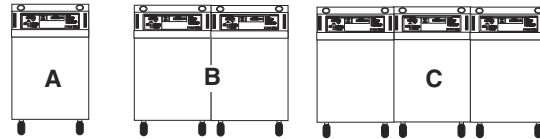

DIMENSIONS in. {mm}			
Cabinet Style	A	B	C
Height	28.0 {710}	28.0 {710}	28.0 {710}
Depth	22.5 {570}	22.5 {570}	22.5 {570}
Width	13.75 {350}	27.5 {700}	41.25 {1050}

SPECIFICATION NOTES	
Two-zone and three-zone models have common wiring and plumbing. Thermolators also can be ordered without heaters for certain applications.	
* Lower operating temperatures can be obtained with larger cooling valves. Consult your Conair representative.	
Specifications can change without notice. Consult Conair for the most current information.	

PERFORMANCE CHARACTERISTICS	
Models	TW-DI
Minimum Setpoint Temperature °F {°C}	35 {1.7}
Maximum Setpoint Temperature °F {°C}	250 {121}
Minimum Operating Temperature °F {°C}	About 20° {11°} above the cooling water inlet temperature*
Standard Cooling Valve Size inches {mm}	1/4 {6.35}
Available pump sizes	0.75, 1, 2, 3, 5 or 7.5 Hp {0.56, 0.75, 1.49, 2.24, 3.73 or 5.59 kW}
Available heater sizes	9, 12, 18, 24, 36 kW

WATER CONNECTIONS	
All models	
NPT inches (female)	
From process	1.25
Cooling water in/out	0.75

PUMP PERFORMANCE - Consult your Conair representative for pump performance characteristics at other operating points.						
Pump	3/4 HP {0.56 kW}	1 HP {0.75 kW}	2 HP {1.49 kW}	3 HP {2.24 kW}	5 HP {3.73 kW}	7.5 HP {5.59 kW}
Nominal Flow gpm {lpm}	40 {151}	45 {170}	55 {208}	80 {303}	100 {379}	115 {435}
Pressure@ Nominal Flow psi {kg/cm ² }	17 {1.2}	18 {1.3}	31 {2.2}	35 {2.5}	43 {3}	51 {3.6}

SHIPPING WEIGHT RANGES lbs {kg} Weights vary depending on cabinet size.						
Pump	Single Zone		2 Zone		3 Zone	
	Min	Max	Min	Max	Min	Max
0.75 HP {0.56 kW}	240 {109}	300 {136}	480 {218}	600 {272}	720 {327}	840 {381}
1 HP {0.75 kW}	240 {109}	300 {136}	480 {218}	600 {272}	720 {327}	840 {381}
2 HP {1.49 kW}	250 {113}	310 {141}	500 {226}	620 {282}	750 {336}	870 {396}
3 HP {2.24 kW}	260 {118}	320 {145}	520 {236}	640 {290}	780 {354}	900 {408}
5 HP {3.73 kW}	270 {122}	330 {150}	540 {244}	660 {300}	810 {366}	930 {423}
7.5 HP {5.59 kW}	280 {127}	340 {154}	560 {254}	680 {308}	840 {381}	960 {435}

TOTAL FULL LOAD AMPS PER ZONE All voltages are 3 phase, 60 Hz.																												
Heater	9 kW				12 kW				18 kW				24 kW				36 kW				0 heaters							
	Voltage		208V	230V	460V	575V	208V		230V	460V	575V	208V		230V	460V	575V	208V		230V	460V	575V	208V		230V	460V	575V		
Pump																												
0.75 HP {0.56 kW}	28.9	26.2	13.1	10.5	37.3	33.8	16.9	13.5	54.0	48.8	24.4	19.5	70.7	64.0	32	25.6	—	—	47.0	37.6	3.9	3.6	2.3	1.5				
1 HP {0.75 kW}	29.4	26.6	13.3	10.6	37.8	34.2	17.1	13.7	54.4	49.2	24.6	19.7	71.2	64.4	32.2	25.8	—	—	47.2	37.8	4.4	4.0	2.5	1.6				
2 HP {1.49 kW}	31.8	28.8	14.4	11.5	40.2	36.4	18.2	14.6	56.8	51.4	25.7	20.6	73.6	66.6	33.3	26.6	—	—	48.3	38.6	6.8	6.2	3.6	2.5				
3 HP {2.24 kW}	34.7	31.4	15.7	12.6	43.1	39.0	19.5	15.6	59.7	54.0	27.0	21.6	76.5	69.2	34.6	27.7	—	—	49.6	39.7	9.7	8.8	4.9	3.6				
5 HP {3.73 kW}	38.5	34.8	17.4	13.9	46.9	42.4	21.2	17.0	63.4	57.4	28.7	23	80.2	72.6	36.3	29.0	—	—	51.3	41.0	13.5	12.2	6.6	4.9				
7.5 HP {5.59 kW}	45.7	41.4	20.7	16.6	54.1	49.0	24.5	19.6	70.7	64.0	32.0	25.6	87.5	79.2	39.6	31.7	—	—	54.6	43.7	20.7	18.8	9.9	7.6				

FEATURES AND OPTIONS

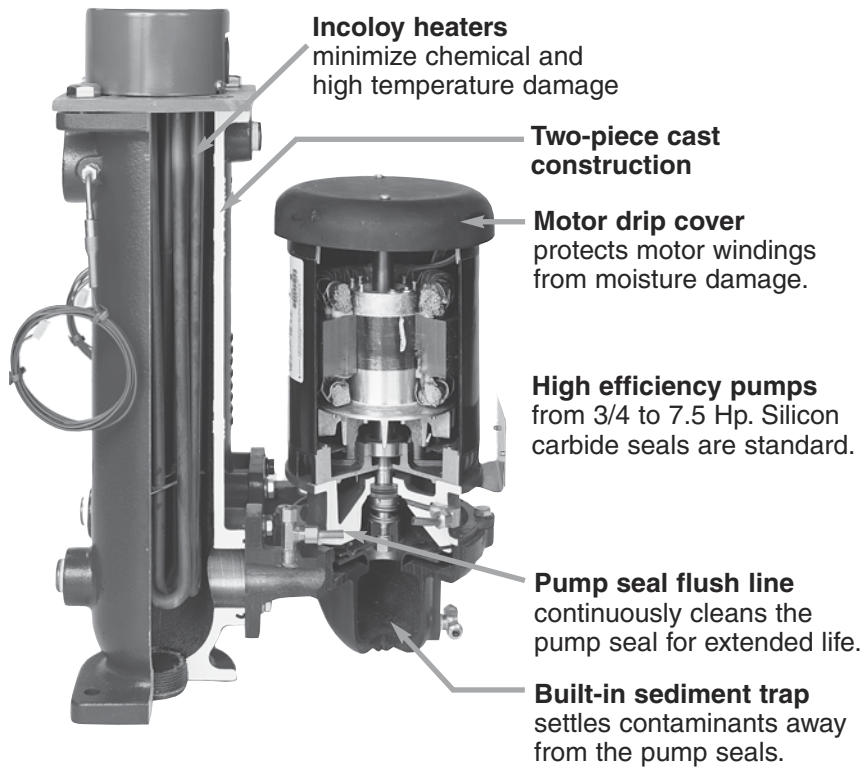

OPTIONS



Motorized Cooling Valve

Eliminates thermal shock from your process circuit by modulating the cooling water.



Compressed Air Mold Purge

Quickly evacuates fluid from the process circuit, allowing for faster, cleaner disconnection of the temperature controller from molds and hoses.



Alarm packages

The Thermolator control includes an output relay that can be connected to an optional external alarm package to call attention to alarm conditions.



Stacking Rack

Save floor space by stacking Thermolators two-high. The stacking rack can be used only with single-zone models in 28-inch high cabinets.

INSTALLATION

- *Unpacking the boxes3-2*
- *Preparing for installation3-3*
- *Connecting the water supply . .3-4*
- *Optional purge valve hookups .3-5*
- *Connecting the main power . . .3-6*
- *Testing the installation3-7*
- *Initial setup3-8*
- *Changing temperature units . . .3-9*
- *Setting SPI communication . . .3-10*
- *Setting the security level3-12*

UNPACKING THE BOXES

Thermolator TW models come fully assembled. If they were specified at the time of the order, the optional purge valve or motorized cooling valve is factory-installed.

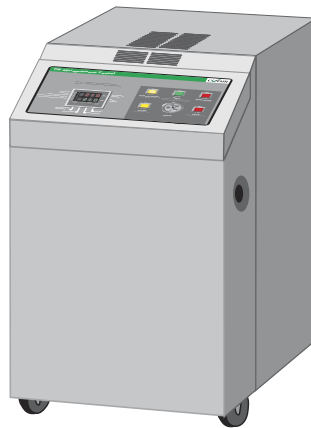

Thermolator

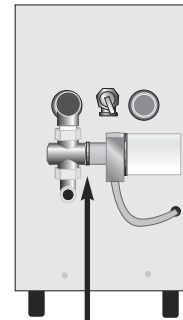

Motorized cooling valve
(optional)

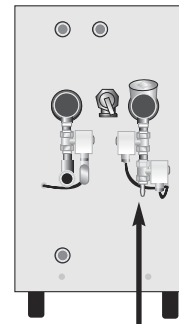

Compressed air mold purge
(optional)

- 1** Carefully remove the **Thermolator** and components from their shipping containers, and set upright.
- 2** Remove all **packing material**, protective paper, tape, and plastic. Check inside the electrical enclosure and behind the side panels for accessories or hardware that may have been placed there for shipping.
- 3** Carefully inspect all **components** to make sure no damage occurred during shipping, and that you have all the necessary hardware. If damage is found, notify the freight company immediately.
- 4** Take a moment to record **serial numbers** and specifications in the blanks provided on the back of the User Guide's title page. The information will be helpful if you ever need service or parts.
- 5** You are now ready to begin **installation**. Complete the preparation steps on the next page.

The Thermolator is easy to install, if you plan the location and prepare the area properly.

PREPARING FOR INSTALLATION

- 1 Position the Thermolator as close to the process machine as possible.**

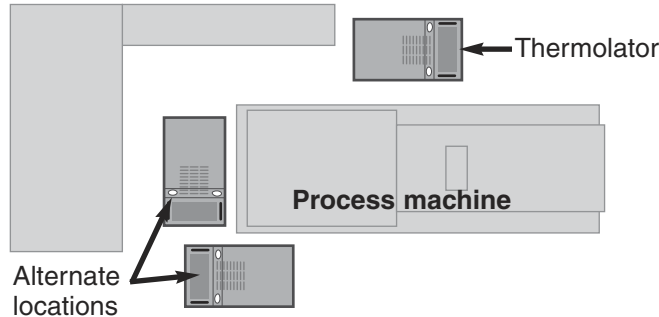

- 2 Make sure the installation area provides:**

❑ **A three-phase power source supplying the correct current** for your Thermolator model. Check the serial tag on the side of the electrical enclosure for the required voltage, phase, frequency, full load amps, disconnect fuse size and minimum wire connection size. Field wiring should be completed by qualified personnel to the planned location for the Thermolator. All electrical wiring should comply with your region's electrical codes.

❑ **A clean, well-ventilated environment.**

The room temperature should not exceed 120° F (48° C) with 95% non-condensing humidity and should not fall below 32° F (0° C).

❑ **Minimum clearance for safe operation and maintenance.** The diagram at right shows minimum clearance for operation. You also need enough clearance in the rear for water hookups. For maintenance, you should move the Thermolator to provide at least 36 inches on any side of the Thermolator.

❑ **A source of water for cooling.**

City, tower or chiller water may be used, as long as the supply pressure is at least 25 psi and not more than 85 psi.

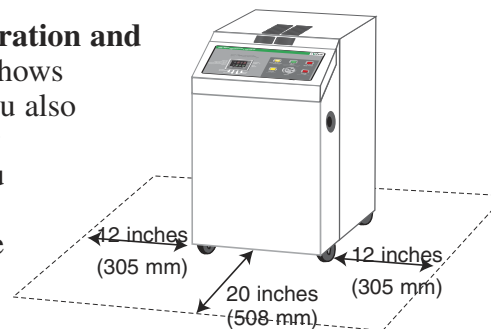

- 3 Install plumbing for process and cooling lines.**

You will need two 1¹/₄-inch NPT male fittings for the process inlet and outlet and two 3/4-inch NPT male fittings for the cooling inlet and outlet. Larger line sizes are acceptable as long as they are reduced at the Thermolator connections. Smaller line sizes are not recommended.

CONNECTING PROCESS AND WATER SUPPLY LINES

Tools for installation:

- ☐ Pipe wrench large enough for a 2-inch pipe
- ☐ Premium quality Teflon thread sealant

NOTE: We recommend that you install an external ball valve on the cooling water inlet of the Thermolator. This valve is required when the purge valve option is installed.

The Thermolator process inlets and outlets must be connected to the plumbing that will circulate the temperature-controlled water or fluid through the process. Cooling water inlets and outlets are connected to the cooling water supply.

- 1 Remove the shipping pipe plug** from the female connections on the back of the Thermolator.
- 2 Install pipe to the rear of the Thermolator.** Use male 1 $\frac{1}{4}$ -inch NPT piping for process connections and male $\frac{3}{4}$ inch NPT piping for water connections. Pipe and pipe threads must be clean and new. Clean threads with solvent, removing all oil, grease and dirt. Allow the threads to dry before proceeding.
- 3 Coat the pipe threads with thread sealant.** Follow the sealant manufacturer's directions.
- 4 Connect the male pipe to the appropriate female connection on the back of the unit.** Start by hand until the threads engage, then use a pipe wrench to tighten the connection only enough to prevent leaks. **Do not over-tighten!**

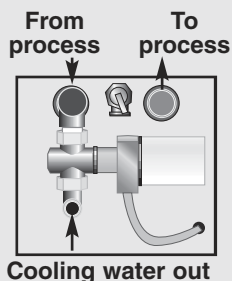
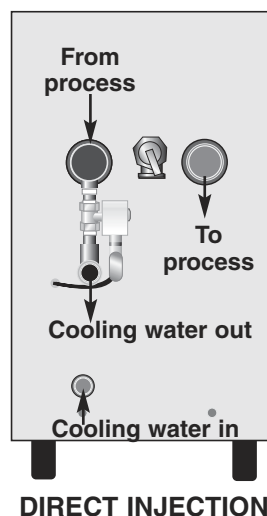

Motorized Cooling Valve

If you have the optional motorized cooling valve, connect the cooling water supply to the female $\frac{3}{4}$ inch NPT fitting on the valve. except as noted, all other connections should be made as described above.

OPTIONAL PURGE VALVE HOOKUPS

A purge valve is available as an option. This valve quickly evacuates fluid from the process circuit, allowing faster disconnection of the temperature controller from molds and hoses. An optional manual purge button controls this valve.

If this option is ordered with the Thermolator, purge control wiring and installation of the valve on the process line outlet of the unit is completed at the factory. You still must connect process and cooling water inlets and outlets, as well as a supply of non-lubricated compressed air.

- 1 Remove the shipping pipe plug** from the female connections on the back of the Thermolator.
- 2 Install an external ball valve on the cooling water inlet of the Thermolator.** This valve is required when a purge valve is used.
- 3 Install pipe to the rear of the Thermolator.** Use male $1\frac{1}{4}$ -inch NPT piping for process connections and male $\frac{3}{4}$ inch NPT piping for water connections. Pipe and pipe threads must be clean and new. Clean threads with solvent, removing all oil, grease and dirt. Allow the threads to dry before proceeding.
- 4 Coat the pipe threads with thread sealant.** Follow the sealant manufacturer's directions.
- 5 Connect the male pipe to the appropriate female connection on the back of the unit.** Connect cooling water lines as indicated on the previous page. Connect process lines as indicated below. Start by hand until the threads engage, then use a pipe wrench to tighten the connection only enough to prevent leaks. **Do not over-tighten!**

- 6 Connect the purge valve to the compressed air supply.** The air pressure should not exceed 100 psi.

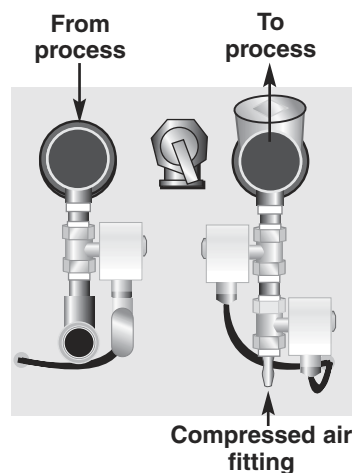

CONNECTING THE MAIN POWER SUPPLY

IMPORTANT: Always refer to the wiring diagrams that came with your temperature control unit before making electrical connections. The diagrams show the most accurate electrical component information.



WARNING: Electrical shock hazard

This equipment is powered by three-phase main voltage. Always disconnect and lock out the main power source before performing any work involving electrical connections. All wiring, disconnects and fusing should conform to your region's electrical codes and should be installed only by qualified personnel.

Before beginning, note the electrical specifications on the nameplate mounted to the side of the unit. The electrical hookup must match these specifications with +/- 10% maximum voltage variance. An improper power supply could damage the unit as well as seriously injure an operator.

The electrical hookup also should run through a fused disconnect sized for the nameplate amperage and conforming to Article 250 of the National Electrical Code.

- 1 Open the unit's electrical enclosure.**
- 2 Insert the main power wire** through the knockout hole in the right side of the enclosure.
- 3 Secure the power wire with a rubber compression fitting or strain relief.**
- 4 Connect the power wires to the terminals.**
Connect the three hot wires to L1, L2, and L3 on the terminal block.
- 5 Connect the ground wire** to the copper grounding mount.
If you have installed a disconnect device, follow the manufacturer's wiring instructions.

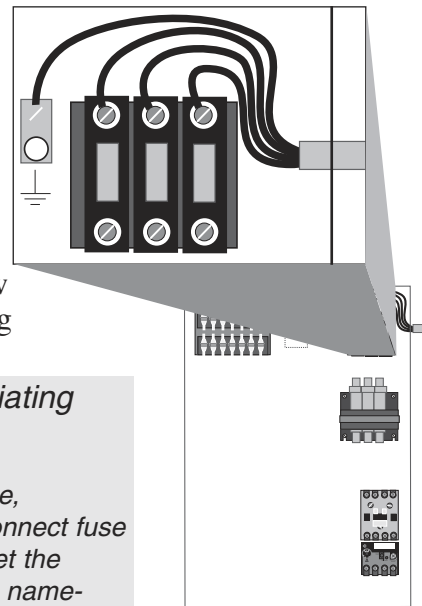

IMPORTANT! Before initiating power to the unit:

- Check the system for leaks.
- Verify that the voltage, phase, frequency, amperage, disconnect fuse and minimum wire size meet the specifications stated on the nameplate mounted on the side of the unit.
- Verify that resistance to ground on each phase is at least 1 meg ohm.



WARNING: Only qualified personnel should perform this procedure.

Parts of this test require opening the unit while it is energized. Only qualified personnel who have been trained in the use of electrical testing devices and in avoiding the safety hazards involved in safely troubleshooting this type of equipment should perform this test procedure.

TESTING THE INSTALLATION

- 1 Turn on the cooling water supply and check for leaks.** If any leaks appear, stop the test and fix the problem before continuing. The cooling water must be at least 25 PSI or the unit will not function. The optional FAULT light will turn on when power is applied. The light goes off when the pressure is correct.

- 2 Apply power to the unit, then press**



- ◆ The power button lights up to indicate the control has power.
- ◆ All LED segments on the display will light for a few seconds while the control performs a selftest. The control then displays the software version, followed by a configuration code (upper display) and communications protocol (lower display) if the SPI option is installed.

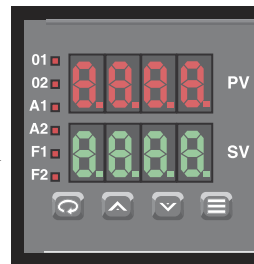

- 3 Check the rotation of the pump.** Remove the top access panel and the pump motor drip cover. Press and hold the START button until the pump starts. Quickly press Pump STOP button and look at the pump. Verify that the pump rotation matches the direction indicated on the rotation sticker on top of the pump motor.

- 4 Replace the drip cover and top access panel.**

- 5 Press and hold the START button until the vent cycle begins.**



If everything is working correctly:

- ◆ The START button lights.
- ◆ The unit initiates a 10-second venting sequence. The pump starts when the venting sequence is over.
- ◆ Normal operation begins. The heater turns on if the actual temperature is below setpoint. The cooling valve is active if the actual temperature is above setpoint.

The test is over. Proceed to initial setup if the unit operated normally; refer to the [TROUBLESHOOTING](#) section if it did not.

NOTE: If the rotation is incorrect, stop the test and disconnect power to the unit. Open the electrical enclosure and switch any two of the three power source wires on the terminal block. Return to Step 2 and check rotation again.

NOTE: If the vent cycle does not begin and the pump does not start, verify that the cooling water supply is connected properly and that the water pressure is at least 25 psi.

INITIAL SETUP

The temperature controller has been configured at the factory to satisfy most applications. But you can change some settings as needed, including:

- The temperature units.
- The security level allowing operator access to settings and parameters.
- The unit identification number (node address) and baud rate for the SPI communications option.

CAUTION: *The Thermolator will not operate correctly if certain factory-set parameters are changed. Parameters should be changed only by qualified technical personnel who are familiar with the operation of this type of equipment. If the Thermolator does not appear to be working correctly, verify the parameters against the list of factory settings.*

For a complete list of the factory-set parameters See **DEFAULT PARAMETERS** in the Appendix. For more detailed information about these parameters and instructions on returning the parameters to the initial factory setup, See the **SERIES 16C INSTRUCTION MANUAL** included with the instruction packet.

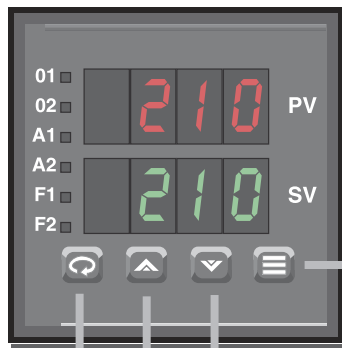

All parameters can be changed using the keypad and the menu system within the temperature controller.

Mode/Enter Key

Used to access operating modes, index through menu items and enter parameter settings.

Lower Key

Used to decrease values or toggle between setting choices.
(Hold for fast-step progression)

Raise Key

Used to increase values or toggle between setting choices.
(Hold for fast-step progression)

Menu Access Key

Used to enter or exit the menu system, index to the next menu and enter the Security Level menu.

The temperature units are factory-set as degrees Celsius, Kelvin or Fahrenheit, as specified when the unit was ordered.



CHANGING TEMPERATURE UNITS

To change this setting:

1 Place the controller in Standby mode.

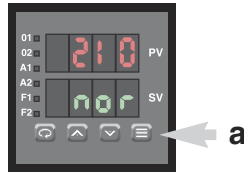
a. Press and hold  for three seconds until the operating mode appears in the lower display.



b. Press  or  until the Standby mode appears in the lower display.

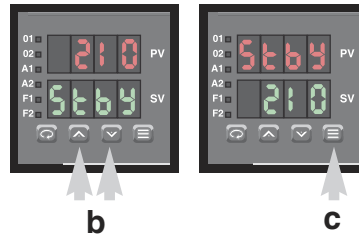

c. Press  again. The upper display will alternate between Standby and the process value. You are now in Standby mode.

2 Press and hold for three seconds to access the menu system.

3 Press until the dSPL (Display) menu appears.

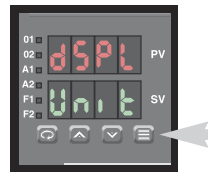

4 Press until Unit appears in the lower display.

5 Press or to select the temperature unit.

F = Fahrenheit
C = Celsius
CAY = Kelvin

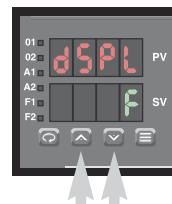

6 Press to index to the next menu with parameter settings you want to change.

If you do not want to change other parameter settings, press and hold  for three seconds to return to the normal operating mode.

SETTING SPI COMMUNICATION (OPTIONAL)

SPI compatible communication support is available as an option on TW Thermolators. The option includes a serial communications card and a serial port installed in the Thermolator.

You can use SPI communication to change or monitor the:

- Process temperature setpoint
- Process status (run and alarm conditions)
- Machine status
- Actual temperature to process

To use the SPI communication option, you must connect the Thermolator to the host machine and set the communication baud rate and node address using the setpoint select and adjustment buttons on the control panel.

1 Connect the host machine to the Thermolator.

Plug the male DB9 connector into the optional serial communications port on the Thermolator.

2 Apply power to the Thermolator.

3 Change the Security Level, if necessary.

The Security Level should be set to the Configuration (CnFg) level. See [SETTING THE SECURITY LEVEL](#).

4 Press and hold  for three seconds to access the menu system.

5 Press  again until the SErL (Serial) menu appears in the upper display.

6 Press  to select the ID number display.

The lower display will flash between Id.no and a numeric value.



7 Press the  or  key to set the unit address.

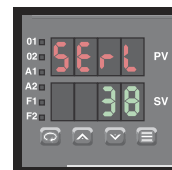

The address may be any number from 32 to 254, as long as the number has not been assigned to another machine connected to the same network.



SETTING SPI COMMUNICATION (OPTIONAL)

- 8** Press  to select the Baud display.
The lower display will flash between bAUD and the numeric value of the baud rate.



- 9** Press the  or  key to set the baud rate.
Baud rate may be set to 1200, 2400, 4800 or 9600 bps.
The Thermolator must be set to send and receive data at the same baud rate as the host machine.

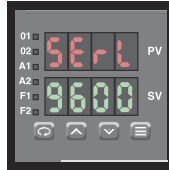

- 10** Press and hold  for three seconds to return to the normal operating display.

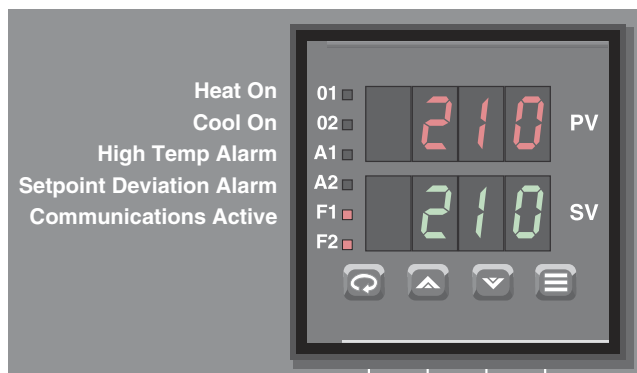

The red communication status lights (F1 and F2) on the temperature controller should flash when the unit is communicating with the host machine.

NOTE: For additional SPI programming information, see the [Series 16C Standard Options and Digital Communications User's Guide](#). This supplement is included with this instruction package if the SPI option is installed.

SETTING THE SECURITY LEVEL

The TW Thermolators provide the ability to protect system parameters from accidental or unauthorized changes. Six security levels are available, allowing various degrees of access to the menus, setpoint and operating mode selections.

We recommend selecting the most restrictive security level that suits your application. The security levels are:



Loc.O	Key Lockout. Highest security level. No access to any controller functions.
SP	Setpoint. Allows setpoint value or output percentage (manual mode) to be changed. No access to menus.
SP.PL	Setpoint Plus Mode. Allows changes to setpoint value, output percentage (manual mode) or the operating mode. No access to menus.
USEr	User. Allows access to all Setpoint Level privileges, as well as access to Operating Mode, Autotune and Control menus.
CnFg	Configuration. Allows access and changes to all parameters and menus except the Calibration menu. Access recommended only for trained service personnel.
FACT	Factory. Lowest security level. Allows access to all parameters, menus and calibration settings. Access recommended only for factory personnel.

To change or view a Security Level:

- 1 Press and hold  for about 10 seconds.**

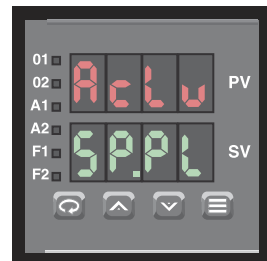
The controller will display AcLv in the upper display and the access level code in the lower display. (Ignore the menu label that appears in the upper display after three seconds.)



- 2 Press  or  to index through the security levels, stopping on the level that you want.**
- 3 Press  once to select the level and exit to the process value display.**

OPERATION

- *The TW control4-2*
- *The TW menu system4-3*
- *Starting the Thermolator4-4*
- *Stopping the Thermolator4-5*
- *Using the manual purge
option4-6*

THE TW CONTROL

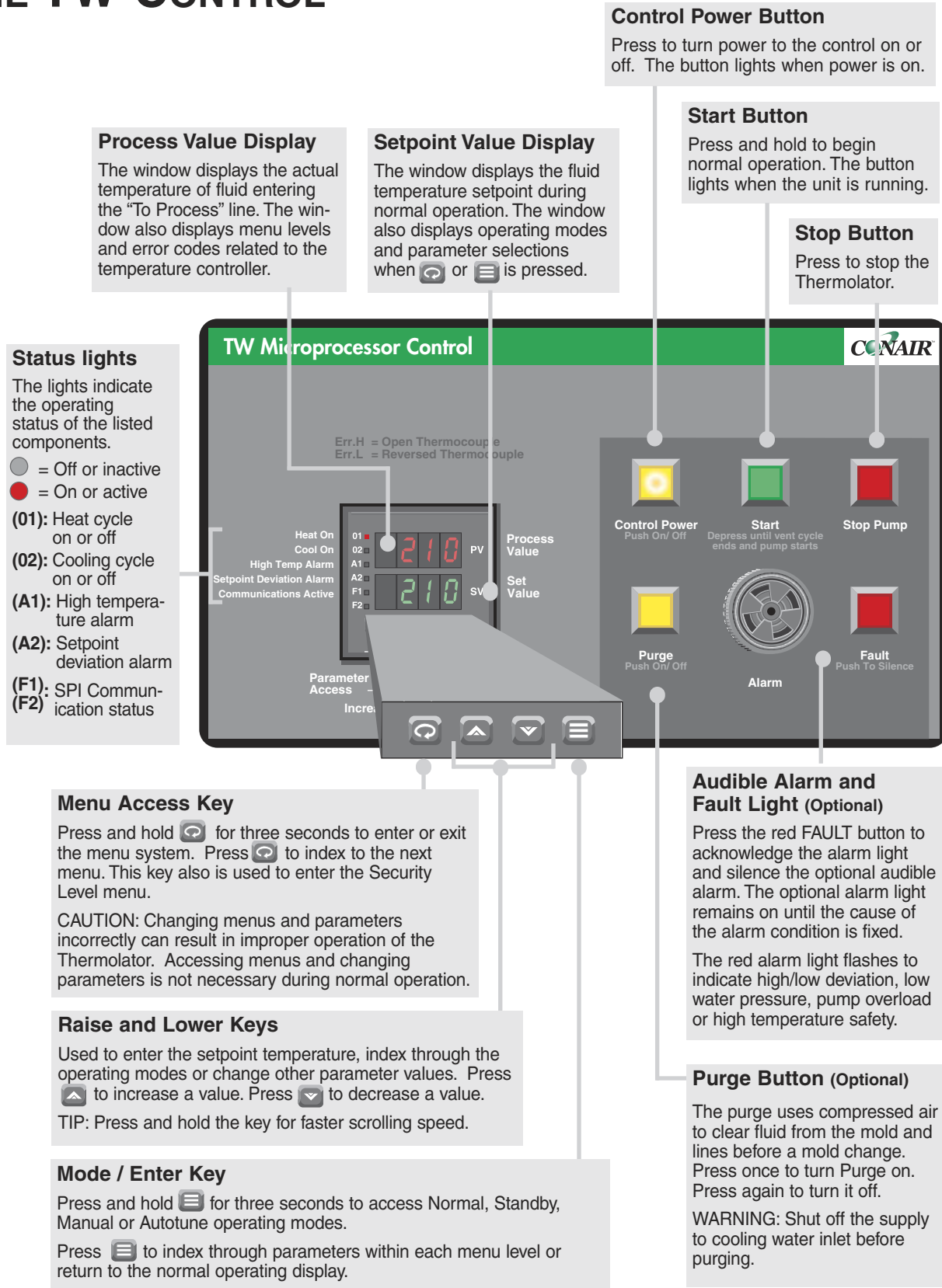

The TW temperature controller uses a menu system to access different operating modes or change system parameters. Please [SEE THE APPENDIX](#) for default parameter settings and detailed information on each of these modes and parameters

THE TW MENU SYSTEM

Operating Modes

nor	Normal. The unit operates with normal automatic control based on the parameters entered during initial setup. The setpoint temperature can be changed in this mode as long as the Security Level allows changes.
StbY	Standby. Use to disable control outputs. You must first be in Standby mode to initiate an Autotune. Standby mode also is recommended when you initially configure the controller.
Atun	Autotune. Use to ensure that the control continues to obtain good approximations of the PID constants used to compensate for the thermal lag of the system. An Autotune should be performed after the first two hours of operation and whenever process variables change. See PERFORMING AN AUTOTUNE.
FOP	Manual. This mode is used for testing only. Manual mode overrides automatic control, allowing you to control heat and cooling outputs by a fixed percentage of output power regardless of the temperature setpoint.

Press and hold  for three seconds to access operating modes.

NOTE: You must be in Standby mode to access Autotune.

Parameter Menus

InP	Input. Use to select sensor-related parameters, such as input type.
dSPL	Display. Use to set or change display units or decimal position.
OutP	Output. Use to specify output usage, control methods and alarms.
Ctrl	Control. Use to select parameters associated with control methods.
ALr	Alarm. Use to select alarm parameters.
tunE	Tune. Use to set autotune damping parameter.
r-S	Recipe. Use to set ramp and soak parameters.
SUPr	Supervisor. Use to set fail-safe and supervisory parameters.
CAL	Calibration. Use to recalibrate input.
OPtn	Option. Use to select an installed option, such as a serial communications card.
SErL	Serial Communications. This menu will appear only if the optional serial communications card is installed. Use to set node address and baud for SPI communication.

Press and hold  for three seconds to access the menus

Press  to index through the menus.

Press  to index through parameters under each menu item.

STARTING THE THERMOLATOR

IMPORTANT: If you are operating the Thermolator for the first time since installation, you should perform an Autotune after two hours of normal operation. You should perform the Auto Tune periodically to ensure that the control correctly calculates how much heat and cooling should be applied to maintain the process setpoint. See [PERFORMING AN AUTOTUNE](#).

Before starting the Thermolator, verify that the system has been installed correctly for your application. See the *INSTALLATION* section.

If the Security Level has been set to Lock Out you will not be able to change the setpoint temperature value. You may need to change the Security Level to modify any of the operating parameters, including the temperature setpoint.

1 Turn on the water supply to the Thermolator.

The supply pressure must be at least 25 psi. Check for leaks in the cooling water and process fluid lines before continuing.

2 Turn on main power to the Thermolator.

Press **CONTROL POWER**



◆ The power button lights to indicate the control has power.

◆ All LED segments on the display will light for a few seconds while the control performs a selftest. The control then displays the software version, followed by a configuration code (upper display) and communications protocol (lower display) if the SPI option is installed.

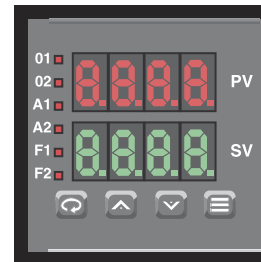

4 Set the temperature setpoint to 35° F.

Press  to increase or  to decrease the temperature setting.

5 Press and hold **START** until the vent cycle begins.

If everything is working correctly:

- ◆ The START button lights.
- ◆ The unit initiates a 10-second venting sequence. The pump starts after the venting cycle is over.
- ◆ Normal operation begins. The heater turns on if the actual temperature is below setpoint. The cooling valve is active if the actual temperature is above setpoint.

6 Set the setpoint to the desired temperature.

Press  to increase or  to decrease the temperature setting.

If the optional Fault light/ alarm turns on, press **FAULT**



to silence the optional audible alarm. Then see the [TROUBLESHOOTING](#) section.

STOPPING THE THERMOLATOR



WARNING: Electrical shock and hot surface hazards

Before attempting maintenance of any kind on the Thermolator, you must stop the unit; disconnect and lockout the main power supply; and allow the unit to cool to less than 100° F (38° C).





You must shut down the Thermolator whenever you:

- Change the water hookups.
- Shut down the process machine.
- Purge the process circuit of the water or fluid.
- Run the unit's diagnostic tests.
- Perform routine or preventative maintenance.
- See an alarm condition that requires troubleshooting.
- Relocate, ship or store the unit.



To shut down the unit for purging the process lines, diagnostic testing, routine maintenance or troubleshooting, press the Stop button. Then refer to the appropriate topic or section in this User Guide for additional instructions.

To shut down the unit to change water hookups:

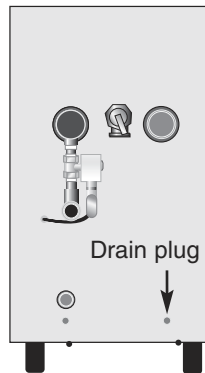
- 1 Press STOP**  **and CONTROL POWER**  .
- 2 Shut off the cooling water supply, and drain the unit of all fluid.** Use the two drain plugs on the back of the unit.
- 3 Once the unit is cool, remove the water hookups.**



To shut down the unit for relocation or storage:

- 1 Press STOP**  **and CONTROL POWER**  .
- 2 Drain the unit of all fluid.**
Drain the unit using the two drain plugs.
- 3 Disconnect the power supply and all water feeds.**

In shipment or storage, the Thermolator can withstand an environment between -40° F (-40° C) and 150° F (65° C) with 95% relative humidity non-condensing.

USING THE MANUAL PURGE OPTION

The TW Thermolator can be ordered with an optional purge valve, which clears the process lines of fluid using compressed air. The valve is operated by an optional manual purge button on the control panel

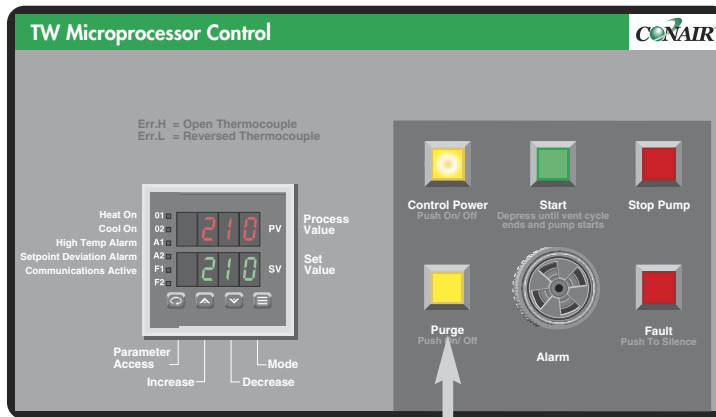

IMPORTANT: Before purging the process lines, be sure that the cooling water source feed is closed. If the feed is open and the air line has a higher pressure than the cooling water, air may be injected into the cooling water system. If the cooling water pressure is higher than the air line, cooling water may be injected into the air line.

1 Press **STOP PUMP**  to stop the Thermolator.

2 Shut off the cooling water supply valve.

3 Press **PURGE**  to start purging.

- ◆ The Purge button lights.
- ◆ The Vent and Cool outputs are activated.
- ◆ The STOP and RUN buttons are deactivated during the purge or when the cool delay off timer is active.

The time required to clear the process lines of fluid will vary according to the length of the process piping and the size of the tooling.

4 Press **PURGE**  again to stop purging.

MAINTENANCE

- *Maintenance schedule5-2*
- *Accessing the Thermolator enclosure5-3*
- *Performing an Autotune5-4*

PREVENTATIVE MAINTENANCE SCHEDULE

Thermolator TW water temperature controllers are essentially maintenance-free. However, to maintain the best performance, we recommend the following maintenance schedule.

- **Whenever process variables change**

- Perform an Autotune.**

The Autotune ensures that the control continues to obtain good approximations of the PID constants used to compensate for the thermal lag of the system.. You should perform an Auto Tune after the first two hours of operation and whenever the process changes, such as after a mold change; installation of different pipe sizes; or change in process setpoint. *See **PERFORMING AN AUTOTUNE.***

- **Daily**

- Check for leaks in cooling and process lines.**

Before and during operation, you should inspect the unit and all plumbing lines for leaks. If a leak develops, stop the Thermolator and repair it.

- Keep the unit and the area around it clean.**

Check for and remove lint, dust or other obstructions on the unit, especially around air intake areas. Keep the floor around the unit dry.

- **Quarterly (every 3 months)**

- Inspect power cords, wires and electrical connections.**

Check for loose or frayed wires, burned contacts, and signs of overheated wires. Check exterior power cords to the main power source and from the electrical box to the pump and heating elements. Check the ground wire and thermocouple connections. Replace any wire that appears damaged or has worn or cracked insulation.



WARNING: Electrical shock and hot surface hazards

Before attempting maintenance of any kind on the Thermolator, you must stop the unit; disconnect and lockout the main power supply; and allow the unit to cool to less than 100° F (38° C)



ACCESSING THE THERMOLATOR ENCLOSURE

To access the Thermolator enclosure:

Remove the top access panel by lifting straight up.
Remove the side panels by lifting straight up.

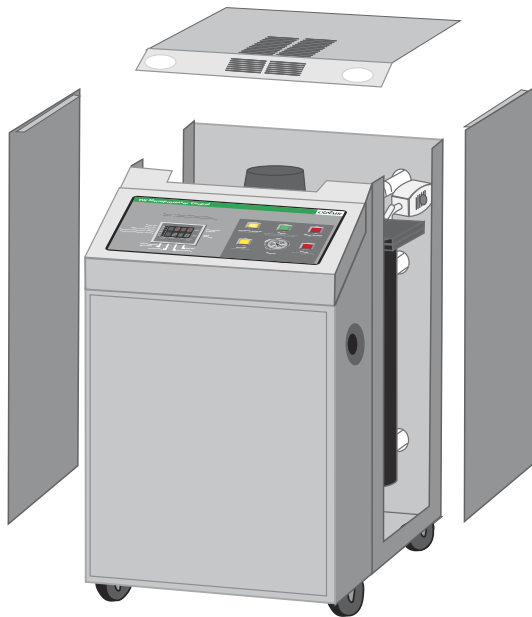

PERFORMING AN AUTOTUNE

You should perform an Autotune after the first two hours of operation and whenever process variables change (changes in cooling water pressure, piping or molds; large ambient swings; new setpoint temperature) to ensure that the control continues to obtain good approximations of the PID constants used to compensate for the thermal lag of the system.

To ensure a successful Autotune, verify that:

- ❑ **The Thermolator has been stopped and the process value is stable.** A fluctuating process value will fool the software into making inaccurate tuning decisions. If the process value is not stable, the Autotune terminates and the control displays an error.
- ❑ **The setpoint/process deviation is at least 25° F.** Tuning accuracy increases as the spread between the process and setpoint values increases. If the absolute value of setpoint minus the process temperature is not at least 25° F, the Autotune terminates and the control displays an error.



To perform an Autotune:

1 Press **STOP**  to stop the Thermolator.

2 Place the controller in Standby mode.

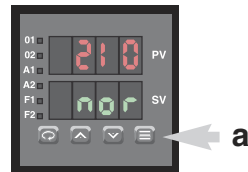
a. Press and hold  for three seconds until the operating mode appears in the lower display.



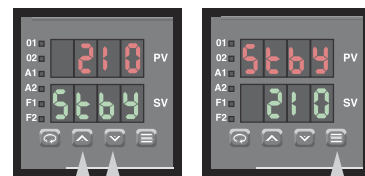

b. Press  or  until the Standby mode appears in the lower display.



c. Press  again. The upper display will alternate between Standby and the process value. You are now in Standby mode.

3 Enter a setpoint value, if one has not been set.





Press  or  until increase or decrease the setpoint.

4 Press and hold **START**  until the pump starts.

continued on next page

PERFORMING AN AUTO TUNE

5 Initiate the Autotune.

- Press and hold  again for three seconds until Ctrl and the operating mode are displayed.
- Press  or  until the Autotune mode appears in the lower display.
- Press  again. The upper display will alternate between “tunE” and the process value while the Autotune is underway.

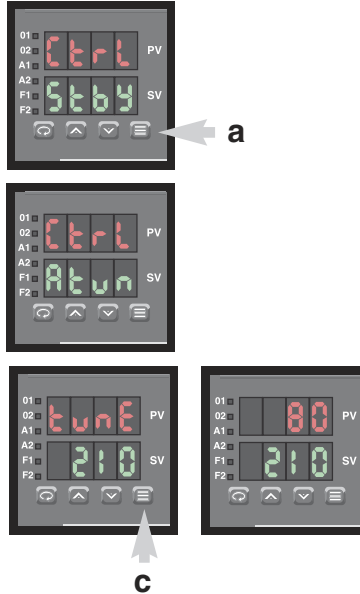

If Autotune is successful, the controller automatically starts controlling using the new PID parameters.

If a fault occurs during the Autotune, the control enters Standby mode and displays the appropriate error message.

ERROR CODE	ERROR DESCRIPTION
02	No PID device configured. Verify that Output 1 Type and Output 2 Type are configured as PID outputs.
03	Incorrect output action. Verify that the outputs are set up and wired correctly. Output 1 should be reverse acting for heating. Output 2 should be direct acting for cooling.
05	Insufficient setpoint/process deviation. If the absolute value of setpoint minus process value is less than 25° F. The Autotune cannot be started until the temperature difference is at least 25° F.
08	Tune timed out. Autotune will time out if a stable process value cannot be obtained. If this error occurs, verify that you followed every requirement under “To ensure a successful Auto Tune” and perform a second tune.
09	Invalid tune results. The most likely causes of this error is a tune started inappropriately or an external element (i.e., loose thermocouple) that upset the process while tuning was in progress. Verify that you followed every requirement under “To ensure a successful Auto Tune” and perform a second tune.

TROUBLESHOOTING

- *Before beginning*6-2
- *A few words of caution*6-2
- *How to identify the cause of a problem*6-3

DIAGNOSTICS

- *Controller alarms*6-4
- *Mechanical/electrical problems*6-10
- *Unit will not power up*6-12

REPAIR

- *Resetting overloads*6-13
- *Replacing the pump overload* .6-13
- *Replacing the temperature controller*6-14
- *Replacing the heater contactor*6-15
- *Checking and replacing thermocouples*6-16
- *Repairing solenoid valves*6-18
- *Replacing heater elements* . . .6-20
- *Removing the pump*6-22
- *Disassembling and assembling 3/4 - 2 HP pumps*6-23
- *Disassembling and assembling 3 - 7.5 HP pumps*6-24

BEFORE BEGINNING

You can avoid most problems by following the recommended installation, operation and maintenance procedures outlined in this User Guide. If you do have a problem, this section will help you determine what caused it and tell you how to fix it.

Before you begin troubleshooting:

- ❑ **Find the wiring, plumbing and other diagrams that were shipped with your equipment.** These diagrams are the best reference for correcting a problem. The diagrams also will note any custom features, such as special wiring, control or plumbing options, not covered in this User Guide.
- ❑ **Verify that you have manuals for other equipment in the process line.** Solving problems may require troubleshooting malfunctions or incorrect operating procedures on other pieces of equipment.
- ❑ **If an alarm is present, note any indicator lights and messages shown on the control panel.** These indicators will help you discover the cause of the problem more quickly.

A FEW WORDS OF CAUTION

The Thermolator is equipped with many safety devices. Do not remove or defeat them. Improper corrective action can lead to hazardous conditions, and should never be attempted to sustain production.



WARNING: This machine should be adjusted and serviced only by qualified technical personnel who are familiar with construction and operation of this type of equipment.



WARNING: Hot surfaces and liquids
Allow the Thermolator to cool to below 100° F (38° C) before servicing the unit.



DANGER: Voltage hazard.

Troubleshooting the electrical system of this equipment requires use of precision electronic measuring equipment, and may require access to the electrical enclosure while power is on. Exposure to potentially fatal voltage levels may be unavoidable. These troubleshooting procedures should be performed only by qualified electrical technicians who know how to use this precision electronic equipment and who understand the hazards involved.

Illuminated alarm lights and error codes on the temperature controller will alert you to many malfunctions. If the optional alarm package is installed, an audible alarm also will activate.

HOW TO IDENTIFY THE CAUSE OF A PROBLEM

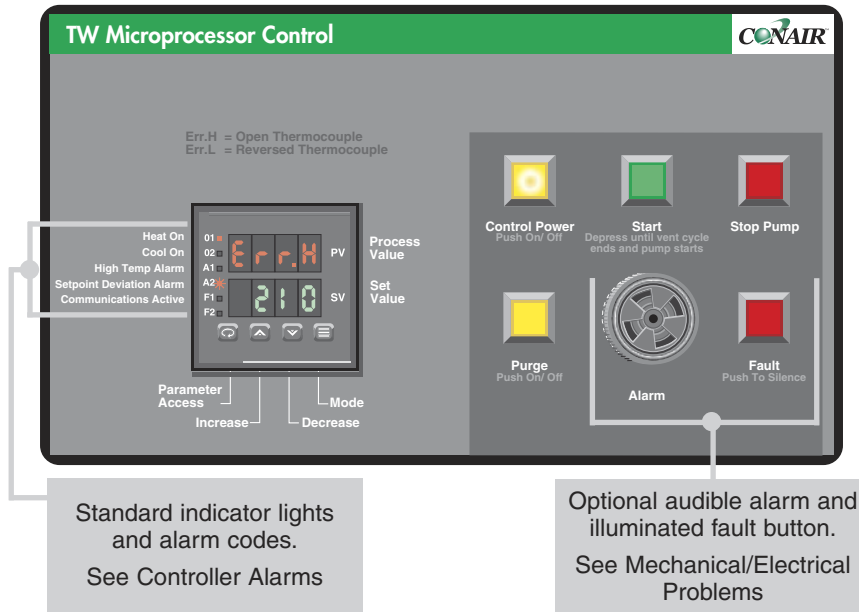

When an Alarm condition occurs:

- 1 Press  to silence optional audible alarm.
- 2 Note any indicator lights or error messages to help determine the cause of the problem.
- 3 Find the alarm or error code in the diagnostics tables in this section of the User Guide. Causes are listed in the order of most likely to least likely problem.
- 4 Determine and fix the cause of the alarm.





WARNING: Always disconnect and lock out the main power source before opening the Thermolator or its electrical enclosure.

Disconnect air and water supply lines as needed.

CONTROLLER ALARMS

The Thermolator has detected a problem that could lead to equipment damage or personal injury if it is not corrected.

- ◆ The controller displays a red alarm LED or an error code indicating the cause of the problem.
- ◆ If the optional alarm package is installed, the Fault button will illuminate and the audible alarm will activate.

Alarm	Possible cause	Solution
<p>High Temp. Alarm </p> <p>The actual temperature of water supplied to the process exceeds the 260° F safety limit that is programmed in the controller</p> <p> WARNING: Only qualified electrical service personnel should examine and correct problems that require opening the unit's electrical enclosure or checking electrical current to diagnose the cause of a problem.</p>	<p>Has water stopped flowing through the unit or between the supply outlet and return inlet?</p>	<ul style="list-style-type: none"> <input type="checkbox"/> Verify that the unit is running and that the pump is working. <input type="checkbox"/> Check for closed or defective cooling or vent valves and plugged lines. See Repairing Solenoid Valves.
	<p>Has the heater contactor failed?</p>	<p>Replace the contactor if defective. See Replacing the Heater Contactor.</p>
	<p>Has the optional electro-mechanical high temperature safety switch been installed on this unit?</p>	<p>If yes, verify the switch setting. A too-low setting will cause nuisance trips. Check the switch and replace if defective. See Checking and Replacing Switches.</p>
<p>Setpoint Deviation </p> <p>The Thermolator will not maintain the setpoint temperature, or takes too long to reach the setpoint temperature range. The actual temperature of water supplied to the process is outside the setpoint deviation alarm band.</p>	<p>Is the actual temperature of the process fluid more than 10° F higher than the setpoint temperature?</p>	<p>Follow the troubleshooting procedures in the table for a High Setpoint Deviation on page 6-5.</p>
	<p>Is the actual temperature of the process fluid more than 10° F lower than the setpoint temperature?</p>	<p>Follow the troubleshooting procedures in the table for a Low Setpoint Deviation on page 6-6.</p>

CONTROLLER ALARMS

The Thermolator has detected a problem that could lead to equipment damage or personal injury if it is not corrected.

- ◆ The controller displays a red alarm LED or an error code indicating the cause of the problem.
- ◆ If the optional alarm package is installed, the Fault button will illuminate and the audible alarm will activate.

Alarm	Possible cause	Solution
<p>High Setpoint Deviation</p> <p>The Thermolator will not cool down, or takes too long to cool down. The actual temperature of fluid supplied to the process is higher than the setpoint deviation allows.</p> <p> WARNING: The Thermolator should be tested and repaired only by qualified technicians equipped with the correct tools and trained in the maintenance and repair of electrical systems and industrial appliances.</p>	<p>Has water stopped flowing between supply outlet and return inlet?</p>	<p>Check for a plugged pipe or closed valve.</p>
	<p>Did the cooling valve fail closed?</p>	<p>Check the cooling valve. See Repairing Solenoid Valves or the Motorized Cooling Valve instructions.</p>
	<p>Is the temperature difference between the cooling water supply and the setpoint too small?</p>	<p>The temperature difference should be at least 25° F to achieve proper cooling. Increase the process setpoint, decrease the cooling water supply temperature or increase the cooling water supply pressure.</p>
	<p>Did a heater contactor fail closed?</p>	<p>With power on and the Heater LED lit: Check the amp draw on each of the three phase legs to the heater. All should match the FLA listed for the heater on the unit nameplate. Replace the heater contactor if there is a voltage imbalance greater than 10%. See Replacing the Heater Contactor.</p>
	<p>Is the cooling valve under-sized for the application?</p>	<p>Check the cooling load (Btu/hr) for which the valve was specified.</p>
	<p>Is the deviation temperature band too narrow?</p>	<p>Increase the deviation band. The recommended setting is the setpoint plus/minus 2° F to 10° F.</p>

CONTROLLER ALARMS

The Thermolator has detected a problem that could lead to equipment damage or personal injury if it is not corrected.

- ◆ The controller displays a red alarm LED or an error code indicating the cause of the problem.
- ◆ If the optional alarm package is installed, the Fault button will illuminate and the audible alarm will activate.

Alarm	Possible cause	Solution
<p>Low Setpoint Deviation</p> <p>The Thermolator will not heat to the setpoint temperature, or takes too long to reach the setpoint temperature. The actual temperature of fluid supplied to the process is lower than the setpoint deviation band allows.</p> <p> WARNING: The Thermolator should be tested and repaired only by qualified technicians equipped with the correct tools and trained in the maintenance and repair of electrical systems and industrial appliances.</p>	<p>Is the cooling valve stuck open or leaking water?</p> <p>Did a heater element fail?</p> <p>Did a heater contactor fail open?</p> <p>Is the deviation temperature band too narrow?</p> <p>Is the Thermolator under-sized for the application?</p>	<p>Disassemble the cooling valve and check for particles blocking the valve seat. Check the valve seat for excessive wear. Replace as required using a valve repair kit. See Repairing Solenoid Valves.</p> <p>With the unit powered down: Check for loose connections. Check resistance between the phase legs on the output side of the heater contactor. Readings should be within 0.25 ohms of each other. Replace the heater, if necessary. See Replacing Heater Elements.</p> <p>With power on and the Heater LED lit: Check the amp draw on each of the three phase legs to the heater. All should match the FLA listed for the heater on the unit nameplate. Replace the heater contactor if there is a voltage imbalance greater than 10%. See Replacing the Heater Contactor.</p> <p>Increase the deviation band setting. The recommended setting is the setpoint plus/minus 2° F to 10° F.</p> <p>Review specifications and selection guidelines that apply to heater and pump sizes in temperature control units.</p>

The Thermolator has detected a problem that could lead to equipment damage or personal injury if it is not corrected.

CONTROLLER ALARMS

- ◆ The controller displays a red alarm LED and/or an error code indicating the cause of the problem.

Alarm	Cause	Solution
<p>Err.H Open Sensor The thermocouple in the process supply line is not working correctly.</p>	Is the thermocouple wired correctly, or is the wire loose?	Check the wiring and wiring connections between the thermocouple and controller. Refer to the wiring diagrams that came with your unit.
	Is the input parameter in the controller set correctly?	Verify that the Input Sensor Type in the controller's Input menu is set to Ca for a Type K Thermocouple. Verify other input settings against the <i>DEFAULT PARAMETERS</i> table in the Appendix.
	Has the thermocouple failed?	Check the thermocouple and replace if necessary. See Checking and Replacing Thermocouple .
<p>Err.L Reversed Sensor The thermocouple in the process supply line has failed.</p> <p> WARNING: The Thermolator should be tested and repaired only by qualified technicians equipped with the correct tools and trained in the maintenance and repair of electrical systems and industrial appliances.</p>	Is the thermocouple wired correctly, or is the wire loose?	Check the wiring and wiring connections between the thermocouple and controller. Refer to the wiring diagrams that came with your unit.
	Is the input parameter in the controller set correctly?	Verify that the Input Sensor Type in the controller's Input menu is set to Ca for a Type K Thermocouple. Verify other input settings against the <i>DEFAULT PARAMETERS</i> table in the Appendix.
	Has the thermocouple failed?	Check the thermocouple and replace if necessary. See Checking and Replacing Thermocouple .

CONTROLLER ALARMS

The Thermolator has detected a problem that could lead to equipment damage or personal injury if it is not corrected.

- ◆ The controller displays a red alarm LED and/or an error code indicating the cause of the problem.

Alarm	Possible cause	Solution
<div data-bbox="277 520 402 590" style="border: 1px solid black; padding: 2px; display: inline-block; margin-bottom: 5px;">LPbr</div> <div data-bbox="415 527 505 590" style="margin-left: 5px;">Loop Break</div> <p data-bbox="274 598 548 867">The input is not changing or responding properly to the output action. This can be caused by a thermocouple, input, heater or load failure.</p> <div data-bbox="277 982 331 1037" style="text-align: center;">  </div> <p data-bbox="339 1010 505 1037">WARNING:</p> <p data-bbox="274 1050 548 1350">The Thermolator should be tested and repaired only by qualified technicians equipped with the correct tools and trained in the maintenance and repair of electrical systems and industrial appliances.</p>	<p data-bbox="583 527 925 625">Is the thermocouple wired correctly, or is the wire loose?</p>	<p data-bbox="967 527 1365 699">Check the wiring and wiring connections between the thermocouple and controller. Refer to the wiring diagrams that came with your unit.</p>
	<p data-bbox="583 724 938 787">Is the input parameter in the controller set correctly?</p>	<p data-bbox="967 724 1365 961">Verify that the Input Sensor Type in the controller's Input menu is set to Ca for a Type K Thermocouple. Verify other input settings against the <i>DEFAULT PARAMETERS</i> table in the Appendix.</p>
	<p data-bbox="583 989 867 1052">Has the thermocouple failed?</p>	<p data-bbox="967 989 1328 1125">Check the thermocouple and replace if necessary. See Checking and Replacing Thermocouple.</p>
	<p data-bbox="583 1150 938 1178">Did a heater element fail?</p>	<p data-bbox="967 1150 1365 1493">With the unit powered down: Check for loose connections. Check resistance between the phase legs on the output side of the heater contactor. Readings should be within 0.25 ohms of each other. Replace the heater, if necessary. See Replacing Heater Elements.</p>
	<p data-bbox="583 1522 894 1585">Did a heater contactor fail?</p>	<p data-bbox="967 1522 1365 1892">With power on and the Heater LED lit: Check the amp draw on each of the three phase legs to the heater. All should match the FLA listed for the heater on the unit nameplate. Replace the heater contactor if there is a voltage imbalance greater than 10%. See Replacing the Heater Contactor.</p>

The Thermolator has detected a non-recoverable error involving the microprocessor control.

- ◆ The controller displays an error code indicating the cause of the problem.

CONTROLLER ALARMS



Alarm	Possible cause	Solution
0100 Checksum Error	Electrical noise or a microprocessor problem caused a failure during power up or operation.	Press any key to perform a soft reset and reinitialize the controller. If the error persists, contact Conair service.
0101 RAM Error	Electrical noise or a microprocessor problem caused a failure during power up or operation.	Press any key to perform a soft reset and reinitialize the controller. If the error persists, contact Conair service.
0202 Defaults Loaded	Electrical noise or a microprocessor problem caused a failure during power up or operation.	Press any key to perform a soft reset and reinitialize the controller. If the error persists, contact Conair service.
0303 EEPROM Write Failure	Electrical noise or a microprocessor problem caused a failure during power up or operation.	Press any key to perform a soft reset and reinitialize the controller. If the error persists, contact Conair service.
38CS	Power fail resume feature disabled.	No further resume actions available.
36_ _ Invalid Interrupt “36” will be followed by a 2-digit code.	Electrical noise, CPU failure or software bug caused an internal software error.	Press any key to perform a soft reset and reinitialize the controller. If the error persists, contact Conair service.

MECHANICAL / ELECTRICAL PROBLEMS

The Thermolator has detected a problem that could lead to equipment damage or personal injury if it is not corrected.

◆ The Fault button illuminates and the audible alarm activates.

NOTE: These alarm indicators are present only if the optional alarm package is installed.



Alarm	Possible cause	Solution
 Low Water Pressure The cooling water pressure is less than 25 psi.	Is the water supply pressure at least 25 psi?	Verify that the water supply is on and delivering water at a pressure of at least 25 psi. Check for closed valve or faulty pump in the supply circuit.
	Did the pressure switch fail?	Watch optional gauges while turning cooling water on and off. If pressure vents automatically, check the cooling valve.
	Did the cooling valve fail?	Check the cooling valve. See Repairing Solenoid Valves or the Motorized Cooling Valve instructions.
 Pump Overload The pump motor overload has tripped. The contact is open.	Is the correct voltage supplied to the pump motor?	Supply voltage should match the rating on the pump name plate. If voltage is correct, check wiring connections.
	Is the required water flow greater than the pump's capacity?	<input type="checkbox"/> Review pump sizing for the application. <input type="checkbox"/> Decrease the water flow to the process.
	Is the motor overload faulty or set incorrectly?	Disconnect the power and open the electrical enclosure. Verify that the overload is set to trip at the proper amperage, which should not exceed the FLA. Manually trip and reset the overload. If the problem continues, replace the overload. See Resetting and Replacing Overloads.
	Is the pump working properly?	Replace the pump if supply voltage, wiring and overload settings are correct, but the pump continues to draw excessive current.

MECHANICAL / ELECTRICAL PROBLEMS

The Thermolator has detected a problem that could lead to equipment damage or personal injury if it is not corrected.

◆ The Fault button illuminates and the audible alarm activates.

NOTE: These alarm indicators are present only if the optional alarm package or optional devices are installed.

Alarm	Possible cause	Solution
<div data-bbox="250 527 329 625">  </div> <p data-bbox="337 527 516 632">High Temperature Safety</p> <p data-bbox="240 632 516 905">The actual temperature of water supplied to the process exceeds the 260° F limit of the optional electro-mechanical safety switch.</p> <div data-bbox="250 919 310 968">  </div> <p data-bbox="315 940 480 974">WARNING:</p> <p data-bbox="240 974 516 1268">Only qualified electrical service personnel should examine and correct problems that require opening the unit's electrical enclosure or checking electrical current to diagnose the cause of a problem.</p>	<p data-bbox="548 527 906 663">Has water stopped flowing through the unit or between the supply outlet and return inlet?</p>	<ul style="list-style-type: none"> <li data-bbox="932 527 1346 663">☐ Verify that the unit is running and that the pump is working properly. Check for correct pump rotation. <li data-bbox="932 663 1346 810">☐ Check for closed or defective cooling or vent valves and plugged lines. See Repairing Solenoid Valves.
	<p data-bbox="548 846 894 982">Is the optional electro-mechanical safety switch improperly set or defective?</p>	<p data-bbox="932 846 1321 1050">Check the switch setting. The maximum setpoint should be 260° F. A setting that is too low will cause nuisance trips. Check the switch and replace if defective.</p>
	<p data-bbox="548 1079 894 1152">Has the heater contactor failed?</p>	<p data-bbox="932 1079 1256 1184">Replace the contactor if defective. See Replacing the Heater Contactor.</p>
<p data-bbox="240 1297 516 1360">SPI Communication Failure</p> <p data-bbox="240 1409 516 1751">If the SPI option is installed, failure will be indicated only by a lack of activity in the F1 and F2 LED lights on the temperature controller when the unit should be communicating with the host machine.</p>	<p data-bbox="548 1297 873 1371">Is the unit connected to the host machine?</p>	<p data-bbox="932 1297 1330 1402">Verify that the Thermolator is connected properly to the host machine.</p>
	<p data-bbox="548 1440 894 1503">Are the network address and baud rate correct?</p>	<p data-bbox="932 1440 1321 1677">Verify the address and baud rate. The address assigned to the unit must not be used by any other machine on the network. The baud rate must match the host machine. See Setting SPI Communication.</p>
	<p data-bbox="548 1715 894 1810">Is something wrong with the communications cable?</p>	<p data-bbox="932 1715 1305 1883">Check the communication cable condition. The cable must conform to SPI standards. Check for loose cable connections.</p>

UNIT WILL NOT POWER UP

If you press the CONTROL POWER button and the control panel does not light, you have a problem with the main power circuit or the unit's temperature controller.



WARNING: Electrical Shock Hazard
Disconnect and lockout the main power supply before proceeding.

Symptom	Possible cause	Solution
Applying power and pressing the Power button on the control panel does not turn on the Thermolator or light the control panel.	Is power reaching the Thermolator?	<ul style="list-style-type: none"> <input type="checkbox"/> Verify that the main power supply and any customer-installed electrical disconnect or emergency stop devices are in the ON position. <input type="checkbox"/> Verify correct electrical connections between the unit and the control, and between the unit and the power supply. Replace any damaged wires or cables.
	Is the correct voltage reaching the Thermolator?	Check the electrical requirements on the unit nameplate. Verify correct main supply voltage to the unit and the secondary voltage supply from the transformer to unit components. Replace the transformer, if necessary.
The Power button on the control panel is illuminated, but the temperature controller does not operate.	Is power reaching the temperature controller?	<ul style="list-style-type: none"> <input type="checkbox"/> Verify that the 16C controller chassis is seated securely in its case housing. See Replacing the Temperature Controller. <input type="checkbox"/> Verify correct electrical connections between the temperature controller and control panel power supply. Refer to the wiring diagrams that came with your unit.
	The temperature controller has failed.	See Replacing the Temperature Controller.

The pump motor overload is located inside the unit's electrical enclosure.

RESETTING OVERLOADS

- 1 Disconnect and lockout the main power.**
- 2 Open the electrical enclosure door.** Turn the screw on the front panel counterclockwise to open.

- 3 Check the overload.**
If the yellow button is out, the overload has tripped. Press the blue button to reset the overload. Verify that the overload trip point does not exceed the FLA for the pump.

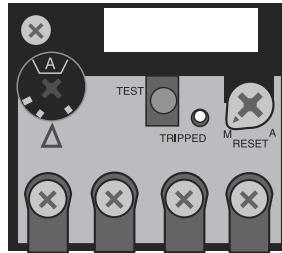

- 1 Disconnect and lockout the main power.**
- 2 Open the electrical enclosure door.** Turn the screw on the front panel counterclockwise to open.
- 3 Locate the pump overload module** attached to the pump motor starter.
- 4 Disconnect the three power leads** from the overload module to the pump motor. Note the placement of each lead and label as needed.

REPLACING THE PUMP OVERLOAD

- 5 Disconnect auxiliary wiring on the overload module.**
- 6 Remove the overload module.** Loosen the three screws that connect the overload module to the motor contactor. Pull the overload module down to release it from the starter.
- 7 Reverse these steps to install the new overload module.**
- 8 Set the module reset mode to M for manual.**
- 9 Set the proper FLA trip point.** Do not exceed the FLA for the pump motor.

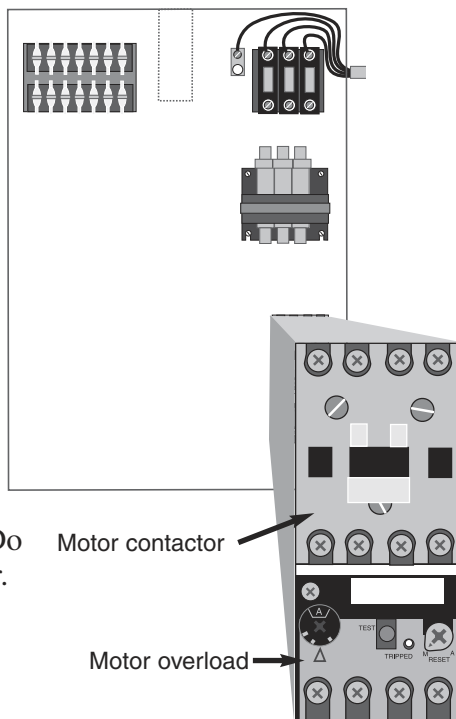

REPLACING THE TEMPERATURE CONTROLLER

IMPORTANT: Always refer to the wiring diagrams that came with your Thermolator to locate specific electrical components. Illustrations in the User Guide are intended to be representative only.

The temperature controller used in the Thermolator TW slides in and out of its casing for easy replacement.

- 1** Disconnect and lockout the main power supply.
- 2** Press the grips on each side of the front panel bezel until the tabs release.
- 3** Pull the controller chassis out of its casing.

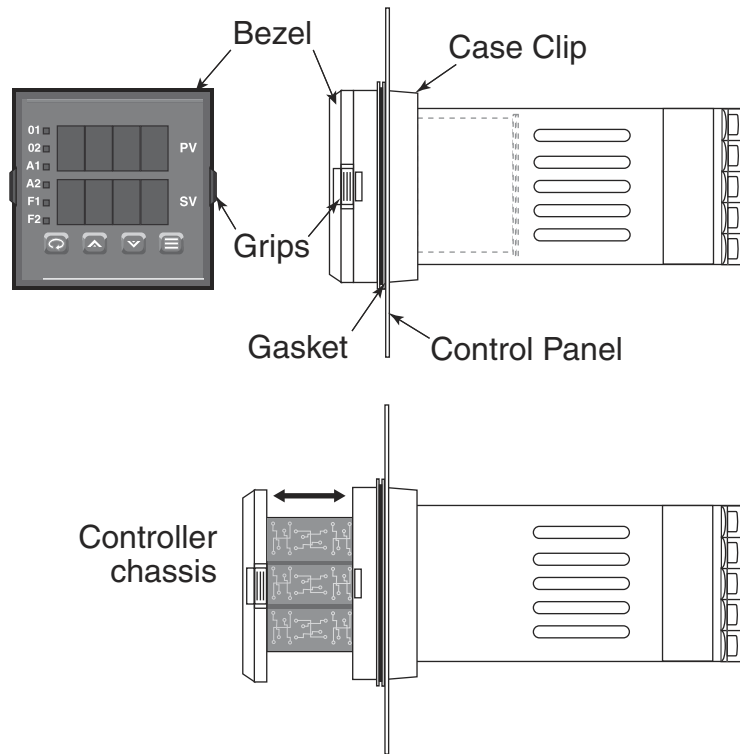

To reinstall or replace the controller:

- 4** Press the grips on each side of the bezel.
- 5** Carefully push the controller back into the casing until the tabs snap into place.
- 6** Program the new controller.
Use the [DEFAULT PARAMETER](#) settings found in the Appendix. For additional information on all the parameters, see the [SERIES 16C INSTRUCTION MANUAL](#) in the Appendix.



WARNING: Electrical Shock Hazard

Only qualified service personnel who have been trained on electrical testing and the procedures for avoiding the hazards should diagnose or correct problems that require opening the unit with power on.

Thermolators use mercury displacement heater contactors. The heater contactors should be replaced if:

- You have checked the amp draw on each of the three-phase legs and discovered a voltage imbalance greater than 10%.
- You have checked the continuity and found that resistance at the coil equals zero ohms.

To replace the heater contactor:

- 1 Disconnect and lockout the main power.**
- 2 Open the electrical enclosure door.** Turn the screw on the front panel counterclockwise to open.
- 3 Disconnect wires from the heater contactor.** Make sure you label the wires to ensure you can connect them correctly to the new contactor.
- 4 Remove the contactor** by removing the screws that hold it in place.
- 5 Discard the old contactor using the proper disposal procedure.** See [Material Safety Data Sheet #7439-97](#) in the *APPENDIX*.
- 6 Reverse this procedure to install the new contactor.** Make sure the wires are connected correctly.

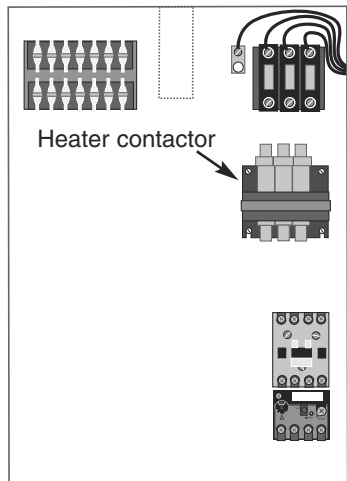

WARNING: Hazardous Substance

Thermolators use mercury displacement contactors. Mercury is considered a hazardous substance and must be dealt with accordingly. See [Material Safety Data Sheet #7439-97-6](#) for information on the how to avoid the potential hazards and how to clean up and dispose of mercury if it spills.

REPLACING THE HEATER CONTACTOR

IMPORTANT: Always refer to the wiring diagrams that came with your Thermolator to locate specific electrical components. Illustrations in the User Guide are intended to be representative only.

CHECKING THE THERMOCOUPLE



WARNING: Electrical Shock Hazard

Only qualified service personnel who have been trained on electrical testing and the procedures for avoiding the hazards should diagnose or correct problems that require opening the unit with power on.

The Thermolator uses a type 'K' thermocouple to monitor the supply process temperature. The thermocouple is installed in the wall of the heater tank at the "to process" outlet.

Sensor error codes (Err.H, Err.L or LPbr) displayed by the temperature controller may indicate thermocouple failure.

To check a thermocouple after a sensor error:

- 1 Disconnect and lockout the main power.**
- 2 Open the electrical enclosure door.** Turn the screw on the front panel counterclockwise to open.
- 3 Remove thermocouple wiring from the controller and install a jumper on the leads.** Refer to the wiring diagrams that came with your unit. Perform a continuity test on the thermocouple. If you detect an open circuit, replace the thermocouple.
- 4 Close the electrical enclosure and restore power to the unit.**
- 5 Restart the Thermolator.**
 - ◆ If error message disappears, replace the thermocouple.
 - ◆ If error message does not disappear, the controller may need to be replaced. Verify the input parameters in the controller, and verify the thermocouple wiring. If wiring and parameters are correct, replace the controller.

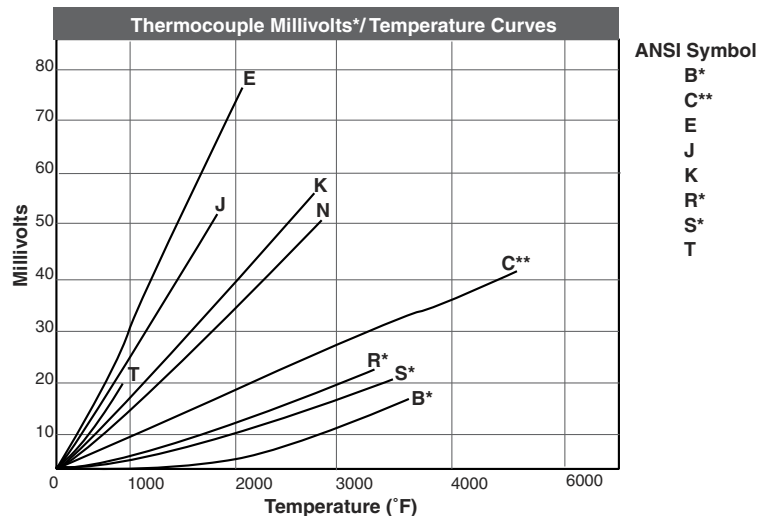



WARNING: Hot surfaces

Allow the Thermolator to cool to below 100° F (38° C) before servicing the unit.

REPLACING THE THERMOCOUPLE

To replace a thermocouple:

- 1** Disconnect and lockout the main power.
- 2** Shut off the cooling water infeed and drain the unit. Drain all water using the drain plugs located the bottom of the unit.
- 3** Remove the unit's top panel and open the electrical enclosure.
- 4** Remove the thermocouple. Loosen the compression nut to slide the thermocouple out of the casing. Disconnect the thermocouple wires at the controller.
- 5** Install the new thermocouple. Insert the tip of the new thermocouple at least 1 inch into the tank. tighten the compression nut. Thread the leads through the raceway leading to the electrical enclosure. Attach the thermocouple leads to the controller.

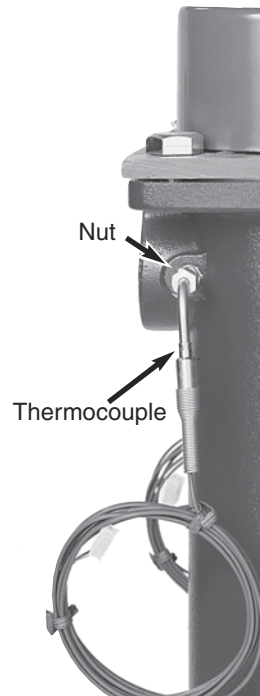

IMPORTANT: Always refer to the wiring diagrams that came with your Thermolator to locate specific electrical components. Illustrations in the User Guide are intended to be representative only.

REPAIRING SOLENOID VALVES

Every Thermolator has a solenoid valve assembly that controls the cooling water out flow. Solenoid valves also are found on the optional purge valve.



WARNING: Electrical shock and hot surface hazards



Before attempting maintenance of any kind on the Thermolator, you must stop the unit; disconnect and lockout the main power supply; and allow the unit to cool to 100° F (38° C)

- 1 Shut off the cooling water infeed.**
- 2 Drain the unit of all water** through the drain plug in the rear of the unit.
- 3 Remove the cooling water out feed.**
- 4 Disconnect and lockout main power.**
- 5 Remove the solenoid valve from the cooling water out line.**
- 6 Disassemble the solenoid valve.**
(See exploded views on next page.)
- 7 Inspect and clean or repair the valve body assembly.** Remove foreign particles and replace damaged parts as necessary.
- 8 Reassemble the valve and other components.** Reassemble in reverse order. Seal all pipe fittings with pipe sealant. Check that all flows are in the correct direction. Check for leaks before resuming operation.

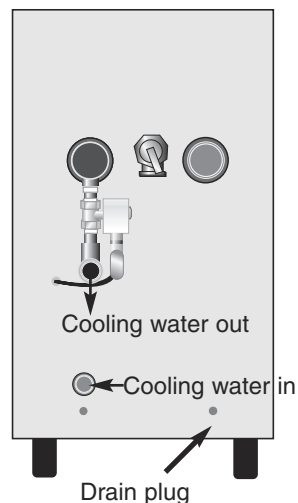

REPAIRING SOLENOID VALVES

*Indicates Parts Supplied in Solenoid Enclosure Kit

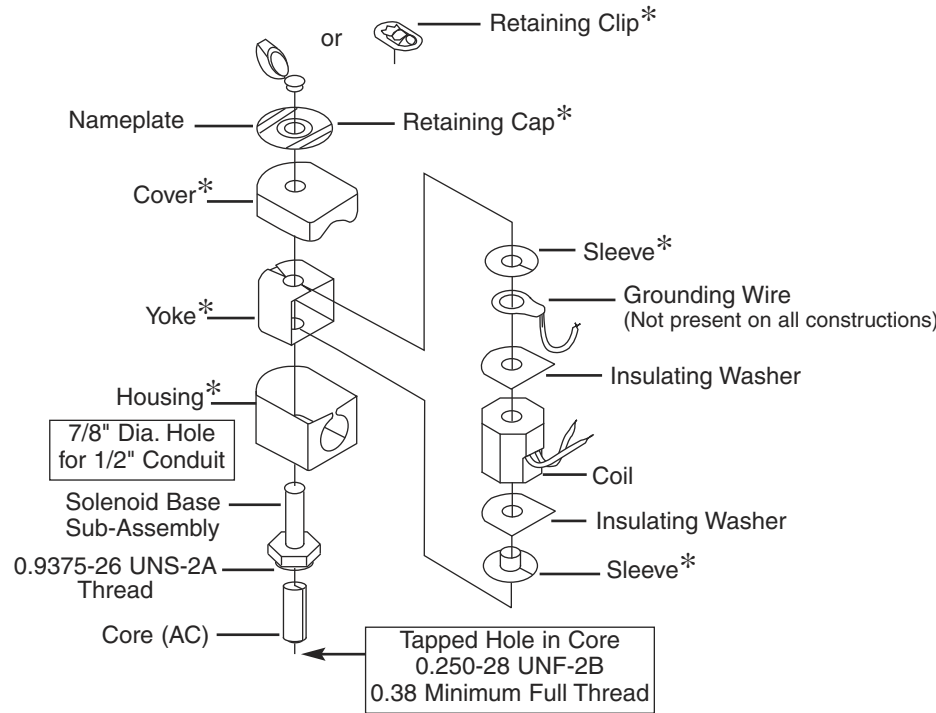

Alternate Construction with Nameplate on Housing

*Indicates Parts Supplied in Solenoid Enclosure Kit

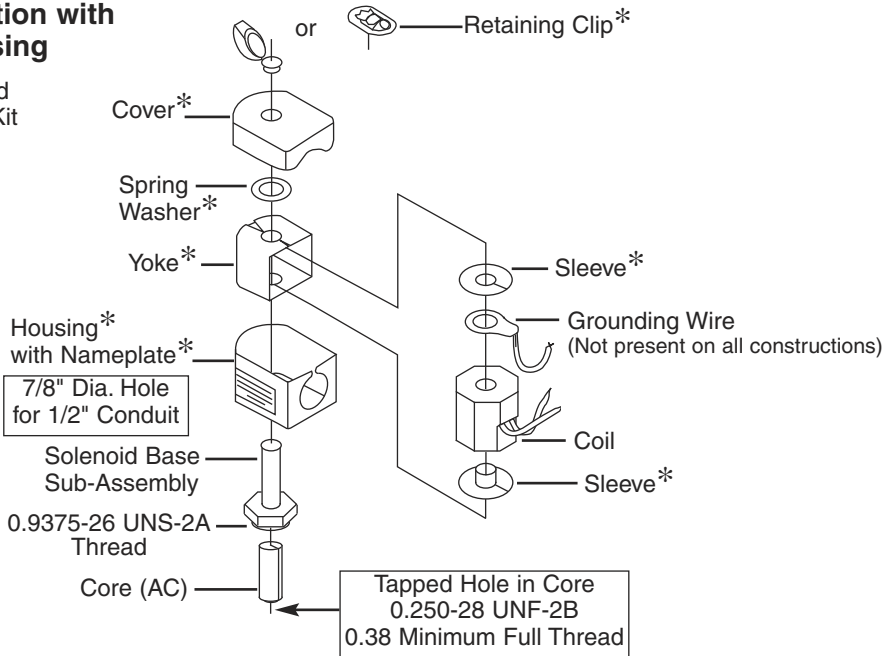

REPLACING HEATER ELEMENTS



WARNING: Electrical shock and hot surface hazards

Before attempting maintenance of any kind on the Thermolator, you must stop the unit; disconnect and lockout the main power supply; and allow the unit to cool to less than 100° F (38° C)



- 1 Disconnect and lockout the main power.**
- 2 Remove the top panel of the Thermolator.**

- 3 Remove the heater cap.**

Use a 1/4-inch open-end wrench to remove the three bolts that hold the cap to the heater tank.

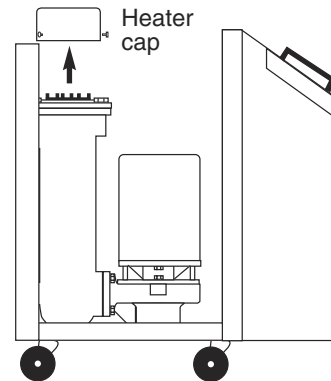

- 4 Remove the heater wiring harness.**

Label the wiring layout of the heater terminals; wires are labeled 2T1, 2T2, 2T3 and GND.

The wiring layout usually will be one of the following:

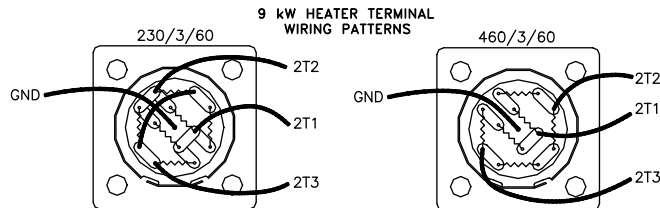

Then unscrew the locking screws on the wiring harness and remove the wires.

- 5 Shut off the cooling water infeed.**
- 6 Drain the Thermolator using the drain plugs located at the rear of the unit.**
- 7 Remove the four bolts that hold the heater element in place.** Use a 15/16-inch socket with 1/2-inch drive.

IMPORTANT: Always refer to the wiring diagrams that came with your Thermolator to locate specific electrical components. Illustrations in the User Guide are intended to be representative only.

REPLACING HEATER ELEMENTS

- 8** Lift the heating element out of the heater tube.
Lift the element straight up.

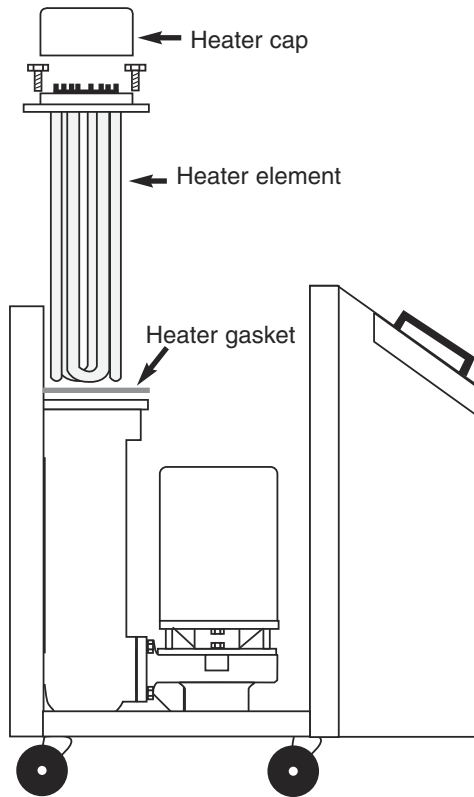

- 9** Clean the heater casting.
Remove any rust or solids that may have built up before inserting the heater elements.
- 10** Replace the heater gasket if it is worn or cracked.
Use a high temperature Teflon paste to ensure a good seal.
- 11** Reverse these steps to install the new heater element and reassemble the unit.

REMOVING THE PUMP



WARNING: Electrical shock and hot surface hazards

Before attempting maintenance of any kind on the Thermolator, you must stop the unit; disconnect and lockout the main power supply; and allow the unit to cool to less than 100° F (38° C)



1 Disconnect and lockout the main power.

2 Shut off the cooling water in feed.

3 Drain the unit of all fluid.
Remove the drain plug at the rear of the unit.

4 Remove the top and side panels of the Thermolator.

5 Remove the seal flush line.
Use a 1/2-inch open-end wrench to remove the vent line from the connection on the pump adapter.

6 Remove the pump assembly bolts. Use a 9/16-inch open-end box wrench to remove the bolts holding the pump to the volute case. The bolt in the rear will require a 9/16-inch crows foot wrench.

7 Lift the pump assembly straight up to remove.
The pump can now be replaced or disassembled for repair.

8 Reverse the steps to reassemble the unit.

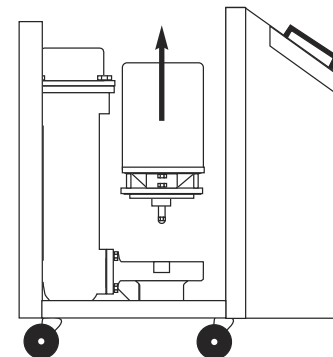
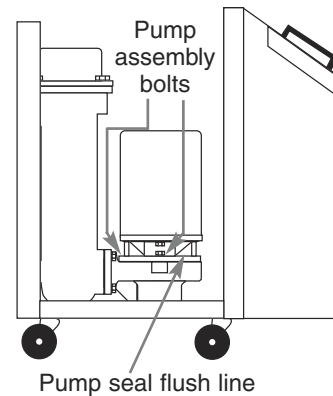
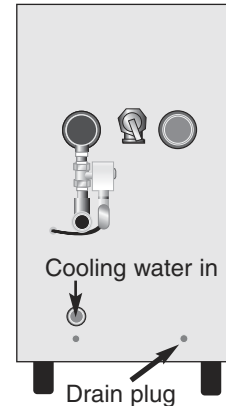

NOTE: Before restarting, close all drain openings using sealant on the threads and reprime the pump. Do not start until the pump is completely filled with water.

DISASSEMBLING AND ASSEMBLING 3/4 - 2 HP PUMPS

To replace a failed seal, you must disassemble the pump.

- 1 Remove the impeller nut.** Insert a screwdriver in one of the impeller waterway passages and back off the impeller nut.
- 2 Remove the impeller.** Insert a screwdriver in the slot of the motor shaft. Unscrew the impeller while holding the shaft against the rotation.
- 3 Remove the seal, gasket case, adapter and flinger.** See the exploded view for detail.

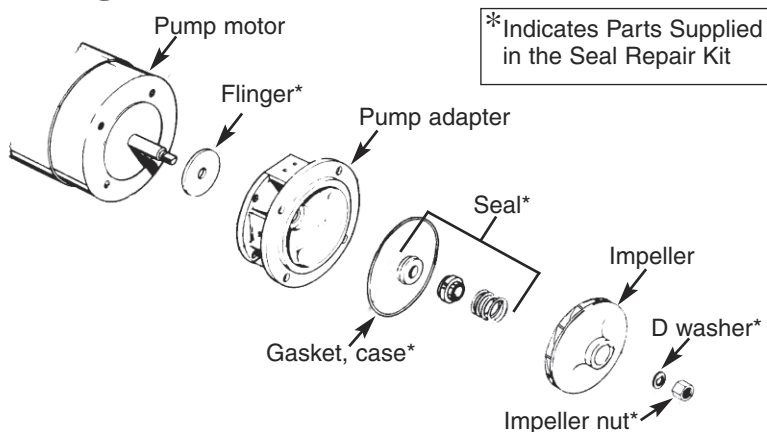

- 4 Clean the gasket and flange faces, seal seat cavity and shaft.** The shaft shoulder that fits against the impeller must be clean.
- 5 Replace the flinger.** Lubricate the seal seat cavity of the adapter and the flinger with soapy water solution before pressing the flinger squarely into the cavity. Do not chip or scratch the lapped seat face.
- 6 Remount the adapter to the motor.** Make sure the motor shaft does not dislocate or chip the seat of the seal.
- 7 Replace the remaining seal components.** Apply a soapy water solution to the motor shaft and the rubber bellows of the rotating seal. Be sure the rotating seal face stays in the holding collar during installation. Do not chip or scratch the lapped seat faces.
- 8 Reassemble the remaining components,** holding the shaft against rotation as previously described. Remove any burrs caused by the screwdriver on the impeller.
- 9 Reattach the pump to the volute case.** Make sure you replace any damaged gasket or O-ring between the pump assembly and volute case. Check for free rotation after assembly is completed.

NOTE: Before restarting, close all drain openings using sealant on the threads and refill the unit with fluid. Do not start the pump when the unit is dry.

DISASSEMBLING AND ASSEMBLING 3 - 7.5 HP PUMPS

To replace a failed seal, you must disassemble the pump.

- 1 Remove the impeller retaining assembly.** Insert a screwdriver in one of the impeller waterway passages to hold the impeller steady while removing the retainer.
- 2 Remove the impeller.** Be careful not to lose the key, spring and seal retainer. If the impeller is difficult to remove, you may need to use a bearing puller.
- 3 Remove the seal, adapter, shaft sleeve and flinger.** See the exploded view for detail.

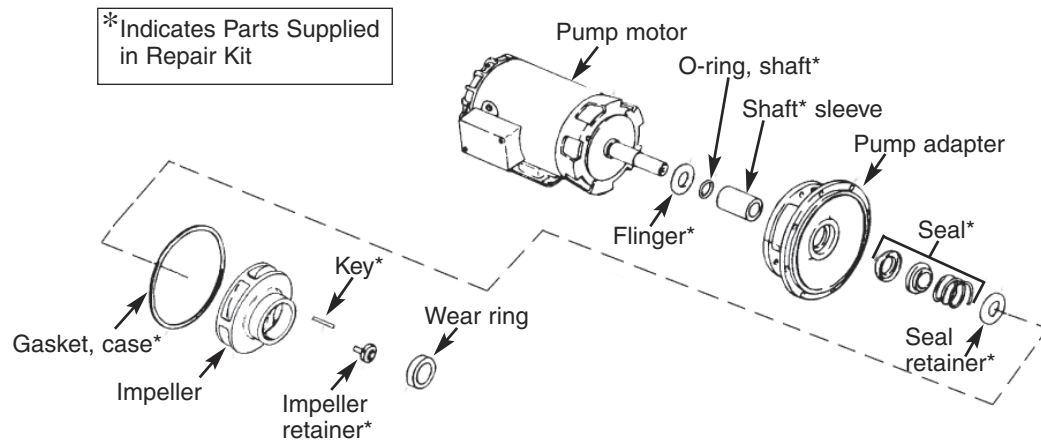

- 4 Clean the gasket and flange faces, seal seat cavity, shaft sleeve and motor shaft.** Replace the shaft sleeve if it is damaged or worn.
- 5 Replace the flinger.** Lubricate the seal seat cavity of the adapter and the flinger with soapy water solution before pressing the flinger squarely into the cavity. Do not chip or scratch the lapped seat face.
- 6 Remount the adapter to the motor.** Make sure the motor shaft does not dislocate or chip the seat of the seal.
- 7 Replace the remaining seal components.** Apply a soapy water solution to the motor shaft and the rubber bellows of the rotating seal. Slide the rotating member of the seal over the shaft sleeve. Replace the seal spring and seal retainer, making sure the rotating seal face stays in the holding collar during installation. Do not chip or scratch the lapped seat faces.
- 8 Place the key in the key seat and slide the impeller on the shaft.** Replace the impeller retaining nut. Remove any burrs caused by the screwdriver on the impeller.

-
- 9** **Reattach the pump to the volute case.** Make sure you replace any damaged gasket or O-ring between the pump assembly and volute case. Check for free rotation after assembly is completed.

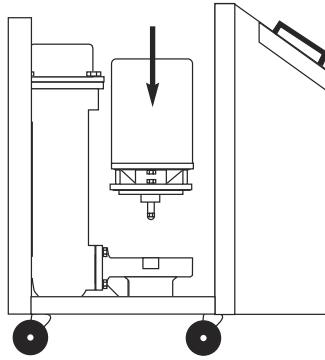

DISASSEMBLING AND ASSEMBLING 3 - 7.5 HP PUMPS

NOTE: Before restarting, close all drain openings using sealant on the threads and and refill the unit with fluid. Do not start the the pump when the unit is dry.

Conair has made the largest investment in customer support in the plastics industry. Our service experts are available to help with any problem you might have installing and operating your equipment. Your Conair sales representative also can help analyze the nature of your problem, assuring that it did not result from misapplication or improper use.

WE'RE HERE TO HELP

To contact Customer Service personnel, call:



HOW TO CONTACT CUSTOMER SERVICE

From outside the United States, call: 814-437-6861

You can commission Conair service personnel to provide on-site service by contacting the Customer Service Department. Standard rates include an on-site hourly rate, with a one-day minimum plus expenses.

If you do have a problem, please complete the following checklist before calling Conair:

- Make sure you have all model, serial and parts list numbers for your particular equipment. Service personnel will need this information to assist you.
- Make sure power is supplied to the equipment.
- Make sure that all connectors and wires within and between control systems and related components have been installed correctly.
- Check the troubleshooting guide of this manual for a solution.
- Thoroughly examine the instruction manual(s) for associated equipment, especially controls. Each manual may have its own troubleshooting guide to help you.
- Check that the equipment has been operated as described in this manual.
- Check accompanying schematic drawings for information on special considerations.

BEFORE YOU CALL ...

Additional manuals and prints for your Conair equipment may be ordered through the Customer Service or Parts Departments for a nominal fee.

EQUIPMENT GUARANTEE

Conair guarantees the machinery and equipment on this order, for a period as defined in the quotation from date of shipment, against defects in material and workmanship under the normal use and service for which it was recommended (except for parts that are typically replaced after normal usage, such as filters, liner plates, etc.). Conair's guarantee is limited to replacing, at our option, the part or parts determined by us to be defective after examination. The customer assumes the cost of transportation of the part or parts to and from the factory.

PERFORMANCE WARRANTY

Conair warrants that this equipment will perform at or above the ratings stated in specific quotations covering the equipment or as detailed in engineering specifications, provided the equipment is applied, installed, operated and maintained in the recommended manner as outlined in our quotation or specifications.

Should performance not meet warranted levels, Conair at its discretion will exercise one of the following options:

- Inspect the equipment and perform alterations or adjustments to satisfy performance claims. (Charges for such inspections and corrections will be waived unless failure to meet warranty is due to misapplication, improper installation, poor maintenance practices or improper operation.)
- Replace the original equipment with other Conair equipment that will meet original performance claims at no extra cost to the customer.
- Refund the invoiced cost to the customer. Credit is subject to prior notice by the customer at which time a Return Goods Authorization Number (RGA) will be issued by Conair's Service Department. Returned equipment must be well crated and in proper operating condition, including all parts. Returns must be prepaid.

Purchaser must notify Conair in writing of any claim and provide a customer receipt and other evidence that a claim is being made.

WARRANTY LIMITATIONS

Except for the Equipment Guarantee and Performance Warranty stated above, Conair disclaims all other warranties with respect to the equipment, express or implied, arising by operation of law, course of dealing, usage of trade or otherwise, including but not limited to the implied warranties of merchantability and fitness for a particular purpose.

The Thermolator will not operate correctly if certain factory-set parameters are changed. Parameters should be changed only by qualified technical personnel who are familiar with the operation of this type of equipment.

DEFAULT PARAMETERS

If the Thermolator does not appear to be working correctly, verify the parameters against the list of factory settings.

For more detailed information about these parameters and returning parameters to the initial factory setup, See the *SERIES 16C INSTRUCTION MANUAL* included with this instruction package.

Menu	Parameter	Description	Setting	Units
InP	TyPE	Input sensor type	Ca	(type K)
	Bias	Bias	0	
	SP.LL	Lower setpoint limit	35	°F
	SP.HL	Upper setpoint limit	250	°F
	I.FIL	Filtering	1.0	Seconds
DSPL	Dec.p	Decimal position	0	
	d.FIL	Display filter	0.1	Seconds
	Unit	Temperature units	F	Fahrenheit
	BLAn	Blanking	OFF	
OutP	O1.tY	Output 1 type	PId	
	O1.Ac	Output 1 action	rE	Reverse acting
	O1.cY	Output 1 cycle type	5	
	O1.LL	Output 1 low power limit	0%	
	O1.HL	Output 1 high power limit	100%	
	O2.tY	Output 2 type	PId	
	O2.Ac	Output 2 action	Dir	Direct acting
	O2.cY	Output 2 cycle type	10	Seconds
	O2.LL	Output 2 low power limit	0%	
	O2.HL	Output 2 high power limit	100%	
CnrL	Pb1	Proportional band 1	5	
	Pb2	Proportional band 2	5	
	DEr	Derivative action - rate	4	
	OFFS	Manual reset	OFF	
	Int	Integral action	21	
aLr	a1.aa	Alarm 1 alarm action	nor	Normal
	a1.ao	Alarm 1 alarm operation	Pro.H	Process high temp
	a1.dL	Alarm 1 delay	0	Seconds
	a1.IH	Alarm 1 inhibit	15	Seconds
	a1.SP	Alarm 1 setpoint	260	°F
	a2.aa	Alarm 2 alarm action	nor	Normal
	a2.ao	Alarm 2 alarm operation	nor.b	High/low deviation
	a2.dL	Alarm 2 delay	0	Seconds
	a2.IH	Alarm 2 inhibit	15	Seconds
	a2.SP	Alarm 2 setpoint	10	°F
TunE	dPnG	Damping for autotuning	nL	Normal
r-s	r.Pot	Ramp to setpoint menu	dIS	Disabled

PLUMBING DIAGRAM

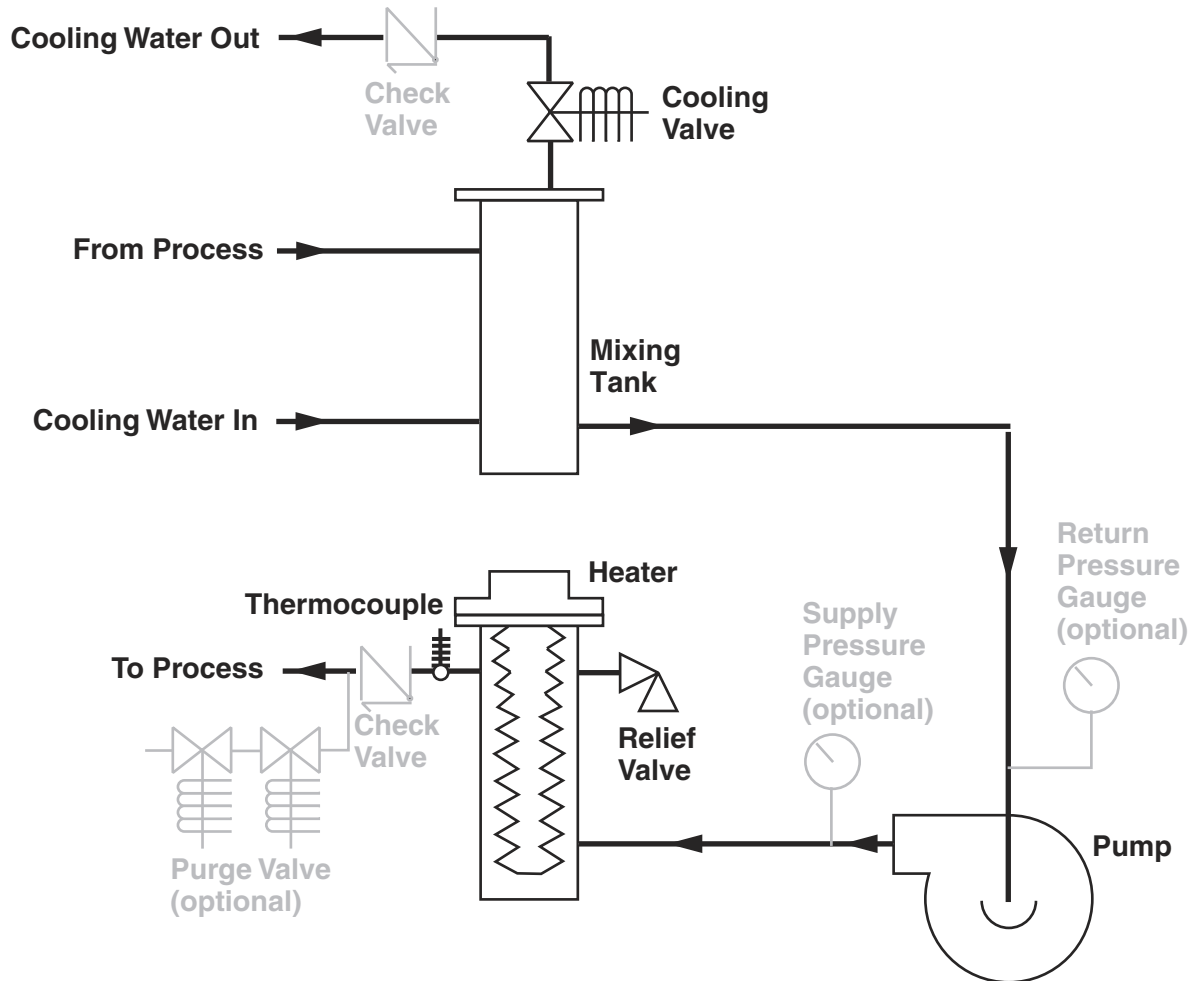

TW Direct Injection

Check valves included only with optional mold purge.

PUMP CURVES

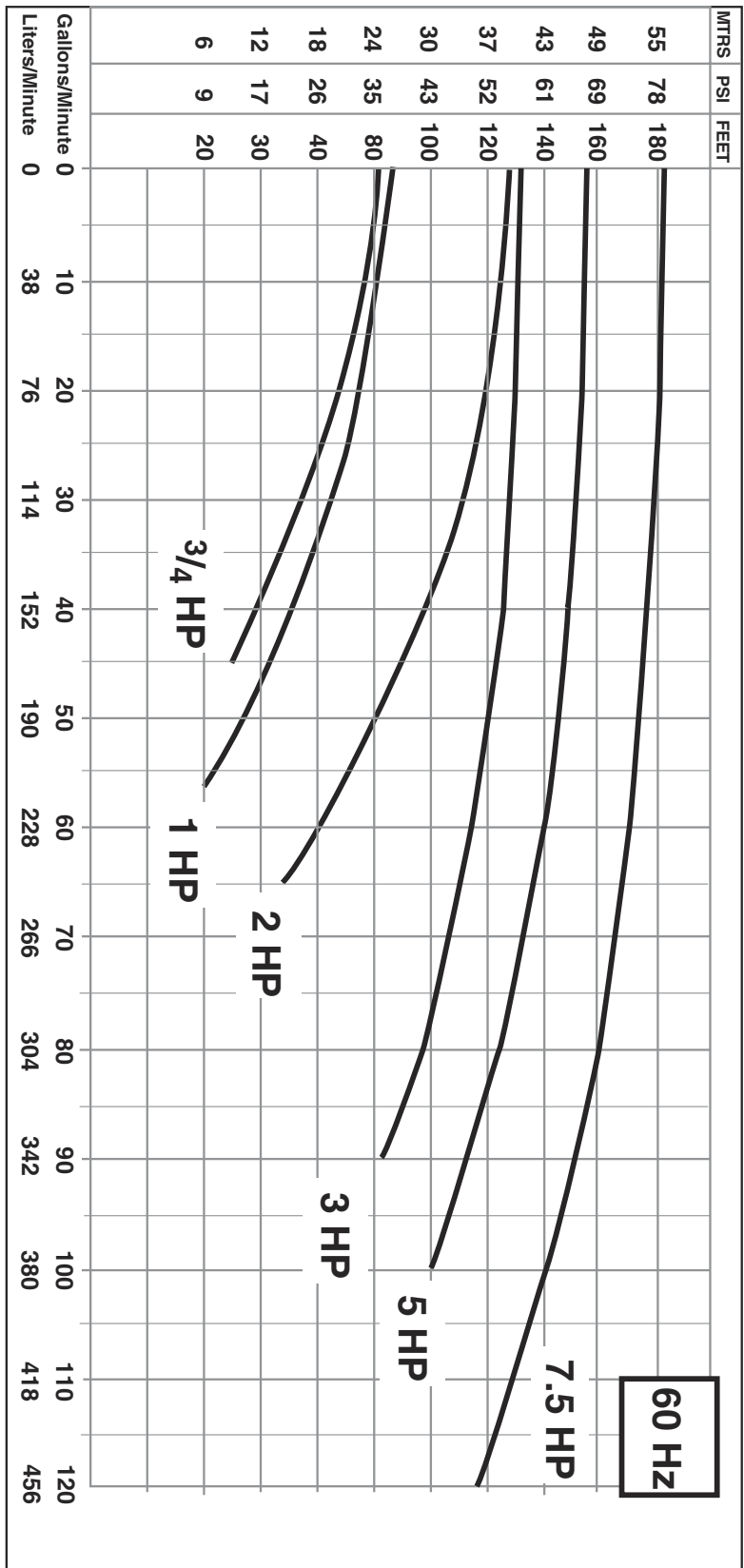

Material Safety Data Sheet

An explanation of the terms used in this document may be found in OSHA 29 CFR 1910.1200, which is available from OSHA regional or area offices.

MSDS: 7439-97-6 MERCURY

1. Chemical Identification		
Substance: Mercury	CAS-Number: 7439-97-6	
Chemical name: Mercury	Synonyms: Quicksilver; Liquid silver	
Formula: HG	Molecular weight: 200.59	
Trade name: Not applicable	Chemical family: Metal	
Supplier of MSDS information: The Conair Group Inc. One Conair Drive Pittsburgh, PA 15202 412-312-6000	Emergency contact: For CHEMTREC assistance call 800-424-9300 (in the U.S.) 703-527-3887 (international)	
2. Composition and Exposure Limits		
Material	Weight (%)	Exposure Limits
Mercury	100	0.05 mg/m ³ Threshold Limit Value(skin)/TWA
		0.1 mg/m ³ Permissible Exposure Limit (PEL)
3. Hazards Identification		
Hazard Ratings (0 = no hazard; 4 = extreme hazard):		
Health	- 4 Extreme (Poison)	Carcinogenic: NTP – No
Flammability	- 0 None	IARC – No
Reactivity	- 1 Slight	Z List – No
Contact	- 3 Severe (Life)	OSHA Reg – No
Personal Health Effects:		
WARNING	Mercury is a dangerous poison and an extreme contact hazard. Mercury may be absorbed by the skin or through the eyes. It may be fatal if swallowed or inhaled. It emits toxic vapors, especially when heated. Do not get mercury in your eyes, on your skin or on your clothing. Do not breathe mercury dust. Keep mercury in a tightly closed container. Use with adequate ventilation. Wash thoroughly after handling.	
Effects of overexposure	Mercury causes skin, digestive tract and severe respiratory tract irritation. It may affect the central nervous system and cause severe eye irritation. Inhalation of vapors may cause coughing, chest pains, nausea and vomiting. Chronic effects of overexposure may include kidney and/or liver damage, and central nervous system depression. Chronic effects of mercury poisoning include a buildup of the metal in the brain, liver and kidneys. Symptoms include headache, tremors, loose teeth, loss of appetite, blisters on the skin and impaired memory. This substance has caused adverse reproductive and fetal effects in animals.	
Target organs	Eyes, skin, respiratory system, central nervous system, kidneys and liver.	
Routes of entry	Inhalation, absorption, eye contact, skin contact.	
4. Emergency and First Aid Measures		
Call a physician immediately.		
If swallowed:	Immediately induce vomiting, if person is conscious.	
If inhaled:	Immediately remove exposed person to fresh air. If the person is not breathing, give artificial respiration. If breathing is difficult, give oxygen.	
In case of contact:	Immediately flush eyes or skin with plenty of water for at least 15 minutes, while removing contaminated clothing and shoes. Wash clothing before using again.	

MSDS: 7439-97-6 MERCURY

5. Fire and Explosion Data	
Fire and explosion hazards:	Mercury presents a slight fire and explosion hazard when exposed to heat or flame. Mercury vapors are heavier than air and may travel a considerable distance to a source of ignition and flash back.
Firefighting media:	Dry chemical, carbon dioxide, water spray or foam. For larger fires, use water spray, fog or alcohol foam. (1984 Emergency Response Guidebook, DOT P 5800.3).
Firefighting procedures:	Use agents suitable for type of fire. Use water in flooding amounts as a fog. Avoid breathing corrosive and poisonous vapors. Keep upwind. Move containers from the fire area if possible. Cool containers exposed to flames with water from side until well after fire is out. (1984 Emergency Response Guidebook, DOT P 5800.3).
6. Spill and Disposal Procedures	
EPA Hazardous Waste Number: U151 (Toxic Waste)	
If spilled or discharged:	Wear self-contained breathing apparatus and full protective clothing. Clean up the spill immediately. Collect and store using a suction pump with a capillary tube. Calcium polysulfide with excess sulfur should be sprinkled into cracks or inaccessible sites. Keep collected mercury in a tightly closed bottle for recovery or disposal.
Disposal procedure:	Dispose in accordance with all applicable federal, state, and local environmental regulations.
7. Storage and Handling Precautions	
Mercury should be stored in a secure poison area inside a tightly closed container.	
8. Exposure Control and Protective Equipment	
Ventilation:	Use general or local exhaust ventilation to meet TLV requirements.
Respiratory protection:	None required where appropriate ventilation conditions exist. If the TLV is exceeded, a self-breathing apparatus is advised.
Eye/skin protection:	Safety goggles and face shield, uniform, protective suit and rubber gloves are recommended.
9. Physical and Chemical Properties	
Appearance and odor: Silver-white, heavy, mobile liquid metal; odorless	
Boiling point: 675° F (357° C)	Melting point: -38° F (-39° C)
Specific gravity: 13.5	Vapor pressure: 0.002 mm HG
Vapor density: 1.01	Solubility in H₂O: negligible, less than 0.1%
Solubility in solvents: Sulfuric acid, nitric acid, lipids	
10. Stability and Reactivity Data	
Stability: Stable	Hazardous polymerization: Will not occur
Conditions to avoid:	Heat
Incompatibles:	Strong acids

IMPORTANT: Users of this equipment should study this MSDS carefully to become aware of and understand the hazards associated with the product. If necessary or appropriate, the reader should consider consulting reference works or individuals who are experts in ventilation, toxicology and fire prevention to use and understand the data in this MSDS. To promote safe handling, the reader should furnish this information to anyone whom he or she knows or believes will use this equipment.

PARTS & DIAGRAMS

- *Parts lists*PD-2
- *Wiring diagram*PD-5

RECOMMENDED SPARE PARTS

TW Thermolators

208-230/460V 9kW & 12kW units, ¼ HP through 7½ HP

MANUALS	
Part No.	Description
UGH014/0100	User Guide, Thermolator TW
QCH013/0200	Quick Card, Thermolator TW
TEMPERATURE CONTROLLER / OPERATOR INTERFACE	
Part No.	Description
20975301	Controller with standard alarms
20975302	Controller with SPI communication option
202017045407	Switch, amber, illuminated (control power; purge option)
09003372	Switch, red, non-illuminated (stop)
09003371	Switch, red, illuminated (fault option)
09003370	Switch, green, illuminated (start)
ELECTRICAL / ELECTROMECHANICAL COMPONENTS	
Part No.	Description
11001213	Thermolator transformer
09003621	Timer
09003622	Timer base
09003443	Relay
09003444	Relay base
11000400	Thermocouple, type K, standard temp unit, 6 feet
11000050	Water pressure switch
09001221	Process pressure gauge
09000328	Pressure relief valve, 150 PSI
09002108	High temperature control, mechanical, option
HEATER CONTACTORS	
Part No.	Description
20004401	Heater contactor for 9kW 208/230/460V
20004401	Heater contactor for 12kW 230/460V
20004501	Heater contactor for 12kW 208V
PUMP OVERLOADS	
Part No.	Description
20003908	Pump overload for: ¼ HP 460V
20003909	Pump overload for: 1 HP 460V
20003910	Pump overload for: ¼ HP 230V and 2 HP 460V
20003911	Pump overload for: ¼ HP 208V and 1 HP 208/230V
20003912	Pump overload for: 3 HP 460V
20003913	Pump overload for: 2 HP 208/230V and 5 HP 460V
20003914	Pump overload for: 3 HP 208/230V and 7½ HP 460V
09000346	Pump overload for: 5 HP 208/230V
09000347	Pump overload for: 7½ HP 208/230V
PUMP STARTERS	
Part No.	Description
20003801	Pump starter for: ¼ HP 208/230/460V
20003801	Pump starter for: 3 HP and 5 HP 460V
20003802	Pump starter for: 3 HP 208/230/460V
20003802	Pump starter for: 7½ HP 460V
20003803	Pump starter for: 5 HP 208/230V
20003804	Pump starter for: 7½ HP 230V
11002015	Pump starter for: 7½ HP 208V

TW Thermolators

208-230/460V, 9kW & 12kW units, ¾ HP through 7½ HP

RECOMMENDED SPARE PARTS

PUMP ASSEMBLIES	
Silicon carbide seal, open drip proof type motor	
Part No.	Description
09000958	¾ HP pump model 12CS (with stainless steel impeller)
09000959	1 HP pump model 12CS (with stainless steel impeller)
09000960	2 HP pump model 12CS (with stainless steel impeller)
09000961	3 HP pump model 50CS (with cast iron impeller)
09000962	5 HP pump model 50CS (with cast iron impeller)
09000963	7½ HP pump model 50CS (with cast iron impeller)
PUMP SEAL OVERHAUL KITS	
Part No.	Description
09000358	¾ HP through 2 HP silicon carbide seal - 12CS
09000359	3 HP through 7½ HP silicon carbide seal - 50CS
REPLACEMENT IMPELLERS	
Part No.	Description
09001417	¾ HP for 12CS model (stainless steel)
09001418	1 HP for 12CS model (stainless steel)
09001414	2 HP for 12C models (stainless steel)
09003313	3 HP for 50C model (cast iron)
09003314	5 HP for 50C model (cast iron)
09003315	7½ HP for 50C model (cast iron)
PUMP PARTS	
Part No.	Description
F92100319	motor pump adapter, ¾ HP through 2 HP
09001466	volute, ¾ HP through 2 HP
09003316	motor pump adapter, 3 HP through 7½ HP
09003107	volute, 3 HP through 7½ HP
PUMPMOTORS	
Part No.	Description
09001403	¾ HP 208/230/460V/3/60 ODP (Open Drip Proof)
09000378	1 HP 208/230/460V/3/60 ODP (Open Drip Proof)
09000381	2 HP 208/230/460V/3/60 ODP (Open Drip Proof)
09000384	3 HP 208/230/460V/3/60 ODP (Open Drip Proof)
09000387	5 HP 208/230/460V/3/60 ODP (Open Drip Proof)
09000390	7 ½ HP 208/230/460V/3/60 ODP (Open Drip Proof)
REPLACEMENT HEATERS	
Part No.	Description
11009001	9 KW 208V/3/60 mild steel
SET AS PARALLEL DELTA	
11009000	9 KW 230/460V/3/60, mild steel
11009002	12 KW 208V/3/60, mild steel
11009001	12 KW 230/460V/3/60, mild steel
09002814	Heater tube casting
09009957	Heater flange gasket
MISCELLANEOUS	
Part No.	Description
09040000	Caster

