

**FURUNO**

**Installation Manual**  
**MULTI-COLOR LCD RADAR**

Model **FR-8045/FR-8065/FR-8125/FR8255**

Product Name: MARINE RADAR

<b>SAFETY INSTRUCTIONS .....</b>	<b>i</b>
<b>SYSTEM CONFIGURATION .....</b>	<b>ii</b>
<b>EQUIPMENT LISTS.....</b>	<b>iii</b>
<b>1. HOW TO INSTALL THE SYSTEM .....</b>	<b>1</b>
1.1 Display Unit.....	1
1.2 Antenna Unit Installation .....	5
1.3 Power Supply Unit .....	19
<b>2. CABLE CONNECTION AND WIRING .....</b>	<b>20</b>
2.1 Standard Connection .....	20
2.2 Wiring the Power Supply Unit (FR-8255 only) .....	21
2.3 Data Signals.....	23
2.4 Input/Output Ports.....	23
<b>3. EQUIPMENT SETTINGS.....</b>	<b>25</b>
3.1 Setting the Language.....	25
3.2 How to Set the Purpose .....	26
3.3 How to Enter Initial Settings.....	27
<b>4. OPTIONAL EQUIPMENT .....</b>	<b>31</b>
4.1 ARP Kit ARP-11 .....	31
4.2 Connection of Buzzer and/or Remote Display .....	33
<b>PACKING LISTS .....</b>	<b>A-1</b>
<b>OUTLINE DRAWINGS .....</b>	<b>D-1</b>
<b>INTERCONNECTION DIAGRAMS.....</b>	<b>S-1</b>



**FURUNO ELECTRIC CO., LTD.**



[www.furuno.com](http://www.furuno.com)

All brand and product names are trademarks, registered trademarks or service marks of their respective holders.



# SAFETY INSTRUCTIONS

Read these safety instructions before you operate the equipment.

 <b>WARNING</b>	Indicates a condition that can cause death or serious injury if not avoided.
 <b>CAUTION</b>	Indicates a condition that can cause minor or moderate injury if not avoided.

 Warning, Caution	 Prohibitive Action	 Mandatory Action
--	--	--

**WARNING**

 **Do not open the equipment unless totally familiar with electrical circuits and service manual.**  
Only qualified personnel should work inside the equipment.

 **Wear a safety belt and hard hat when working on the antenna unit.**  
Serious injury or death can result if someone falls from the radar mast.

**Construct a suitable service platform from which to install the antenna unit.**  
Serious injury or death can result if someone falls from the radar mast.

**Turn off the power at the mains switchboard before beginning the installation.**  
Fire, electrical shock or serious injury can result if the power is left on or is applied while the equipment is being installed.

**CAUTION**

 Ground the equipment to prevent electrical shock and mutual interference.

**WARNING**

 **Radio Frequency Radiation Hazard**

The radar antenna emits electromagnetic radio frequency (RF) energy which can be harmful, particularly to your eyes. Never look directly into the antenna aperture from a close distance while the radar is in operation or expose yourself to the transmitting antenna at a close distance.

Distances at which RF radiation levels of 100 W/m<sup>2</sup> and 10 W/m<sup>2</sup> exist are given in the table below.

**Note:** If the antenna unit is installed at a close distance in front of the wheel house, your administration may require halt of transmission within a certain sector of antenna revolution. This is possible - Ask your FURUNO representative or dealer to provide this feature.

Model	100W/m <sup>2</sup>	10W/m <sup>2</sup>	
FR-8045	XN-12A	N/A	1.1m
	XN-13A	N/A	1.0m
FR-8065	XN-12A	N/A	1.9m
	XN-13A	N/A	1.7m
FR-8125	XN-12A	N/A	2.1m
	XN-13A	N/A	1.9m
FR-8255	XN-12A	0.6m	4.6m
	XN-13A	0.4m	3.1m

**CAUTION**

Observe the following compass safe distances to prevent deviation of a magnetic compass.

Model	Standard	Steering	
Display Unit RDP-154	1.00m	0.65m	
FR-8045 Antenna	0.95m	0.60m	
FR-8065 Antenna	RSB-0070	1.95m	1.25m
	RSB-0073	1.90m	1.20m
FR-8125 Antenna	RSB-0070	1.00m	0.60m
	RSB-0073	1.10m	0.70m
FR-8255 Antenna	RSB-0070	1.85m	1.25m
	RSB-0073	1.80m	1.15m
PSU-008	0.80m	0.50m	

# SYSTEM CONFIGURATION

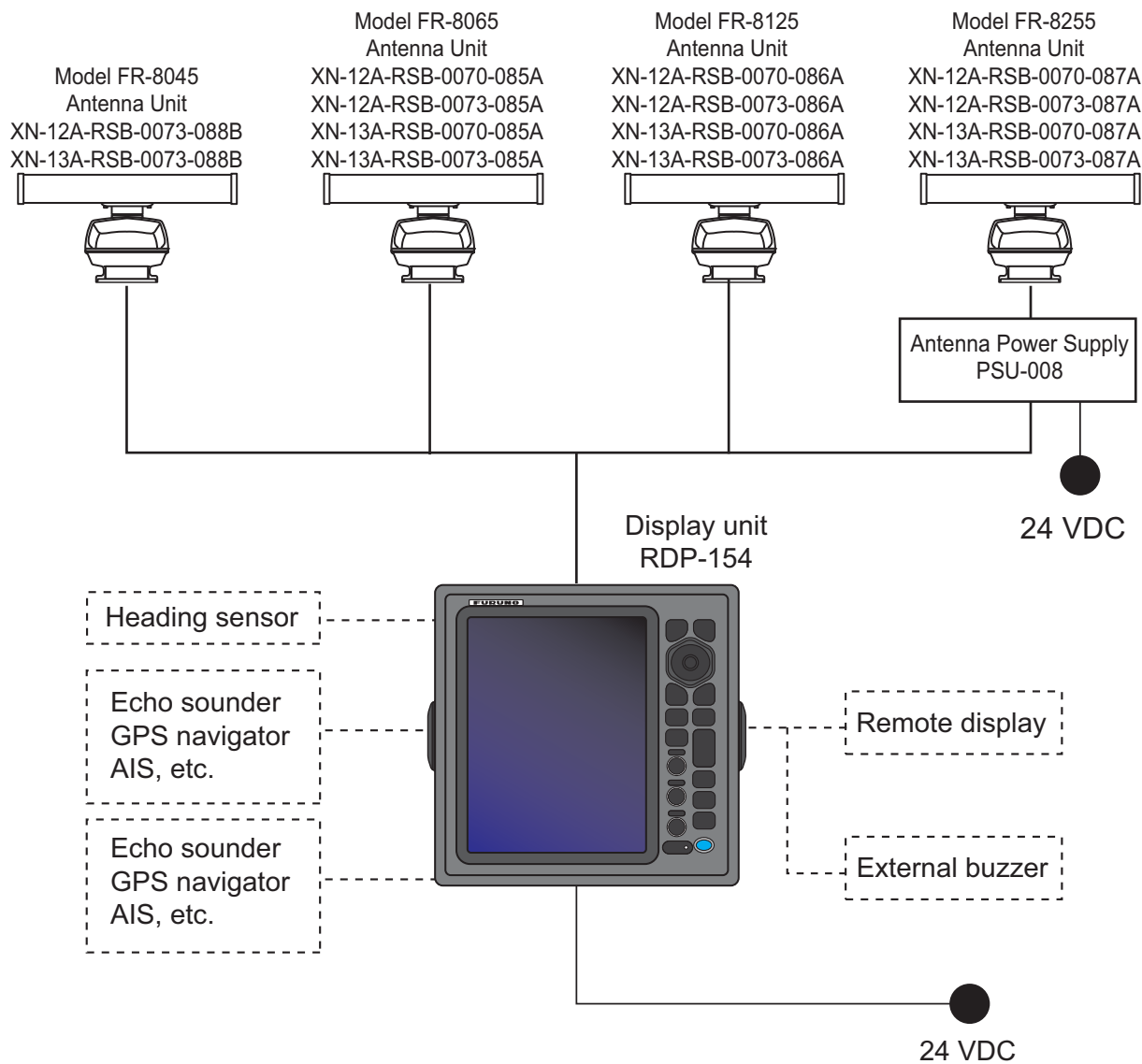

————— : Basic configuration

----- : Optional

**Note 1:** 12 VDC cannot be used with this equipment.

**Note 2:** When replacing the antenna, make sure the correct SPU board is used, referring to the table below.

Model	SPU Board
FR-8045	03P9586B
FR-8065/FR-8125/FR-8255	03P9586A

# EQUIPMENT LISTS

## Standard Supply

Name	Type	Code No.	Qty	Comments	
Display Unit	RDP-154	—	1		
Antenna Unit	RSB-0070/0073-085A	—	1	Radiator: XN-12A or XN-13A	
	RSB-0070/0073-086A	—			
	RSB-0070/0073-087A	—			
	RSB-0073-088B	—			
Power Unit	PSU-008	—	1	5m Cable	For FR-8255
Installation Materials	CP03-30700	000-090-471	1	10m Cable	For FR-8065/ or FR-8125
	CP03-30710	000-090-472		15m Cable	
	CP03-30720	000-090-473		20m Cable	
	CP03-30730	000-090-474		30m Cable	
	CP03-30500	000-083-620	1	10m Cable	For FR-8255
	CP03-30510	000-083-621		15m Cable	
	CP03-30520	000-083-622		20m Cable	
	CP03-30530	000-083-623		30m Cable	
	CP03-35600	000-024-717	1	For Display Unit (Screws, Code: 000-162-608-10, 5×20 SUS304)	
	CP03-33000	000-014-604	1	5m Cable	For FR-8045
	CP03-33010	000-014-605		10m Cable	
	CP03-33020	000-014-606		15m Cable	
	CP03-33030	000-014-607		20m Cable	
	CP03-33040	000-014-608		30m Cable	
	CP03-33801	001-141-670	1	For Antenna Unit: FR-8065/FR-8125/FR-8255	
	CP03-18401	008-503-360	1	For Antenna Unit: FR-8045	
	CP03-22901	008-219-760	1	For Radiator	
CP03-30600	000-084-769	1	For PSU-008		
Spare Parts	SP03-17701	001-258-000	1	For Display Unit: Fuse (Code: 000-155-826-10, FGBO 125V 10A PBF)	
	SP03-14501	008-444-420	1	For PSU-008	
Accessories	FP03-12301	001-258-020	1	LCD Cleaning Cloth (Code: 100-360-672-10, 19-028-3125-2)	

**Optional supply**

<b>Name</b>	<b>Type</b>	<b>Code No.</b>	<b>Qty</b>	<b>Comments</b>
Auto Plotter	ARP-11	008-523-050	1	
External Alarm Buzzer	OP03-21	000-030-097	1	
Signal Cable Assembly	MJ-B24LPF0010-100+R	000-147-880-12	1	For Remote Display Unit
	MJ-B24LPF0010-200+R	000-147-881-12		
	MJ-B24LPF0010-300+R	000-147-882-12		
	MJ-A7SPF0007-050C	000-154-028-10	1	For NMEA1/2
	MJ-A6SPF0007-100C	000-159-695-10	1	For Heading Sensor
	MJ-A10SPFW0001+R	001-074-600-10	1	For Remote Display Unit/ External Display splitter cable
Flush Mount Kit	OP03-228	001-258-030	1	

# 1. HOW TO INSTALL THE SYSTEM

---

## NOTICE

**Do not apply paint, anti-corrosive sealant or contact spray to plastic parts or equipment coating.**

These items contain products that can damage plastic parts and equipment coating.

## 1.1 Display Unit

Select a location for the display unit by following the information shown below.

- The unit is waterproof, but FURUNO recommends that you install the display unit in a cabinet.
- Keep the unit away from direct sunlight.
- The temperature and humidity must meet the requirements shown in the equipment specifications.
- Set the unit away from the exhaust pipes and vents.
- The installation location must have enough cool air.
- Install the unit where shock and vibration meet the requirements shown in the equipment specifications. If there is heavy vibration, vertically install the display unit on the hanger.
- Keep the unit away from equipment that creates an electromagnetic field, for example, motors and generators.
- For maintenance and checking, leave enough space at the sides and rear of the unit, referring to the outline drawing and provide some additional length in cables.
- Follow the recommended compass safe distances shown on page i to prevent the interference to a magnetic compass.

### 1.1.1 How to install the display unit

#### How to install the display unit on a desktop or overhead

Follow the procedure shown below to install the display unit on a desktop or overhead.

1. Unfasten the knob bolts and remove the display unit from the hanger.

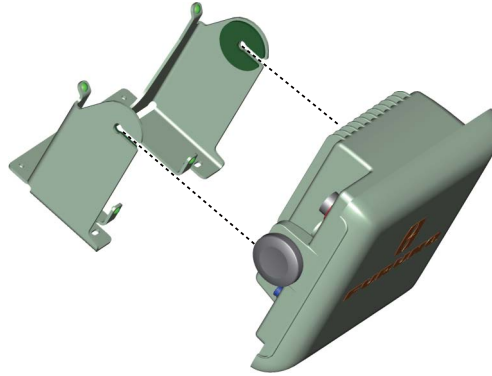

2. Fasten the hanger with four self-tapping screws.

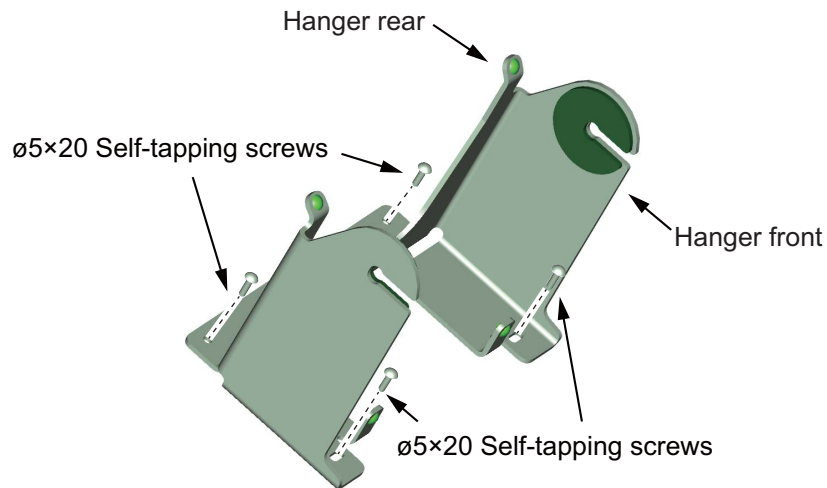

3. Screw the knob bolts into the display unit, leaving them slightly loose.

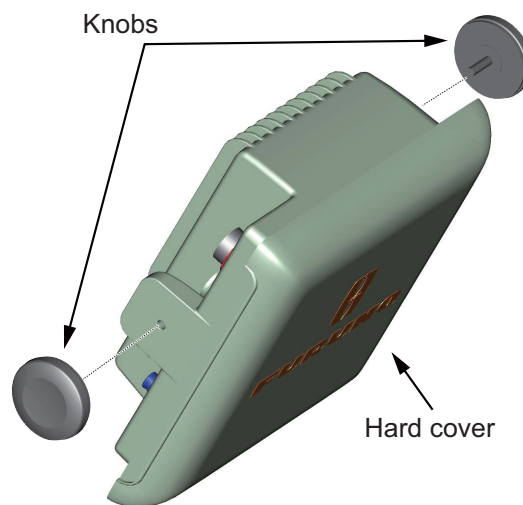

4. Connect all necessary cabling.
5. Set the display unit in the hanger, then fasten the knob bolts.

**Note:** For overhead installation, make sure the location is strong enough to hold the unit. If necessary, fasten the hanger with the bolts, nuts and washers (local supply).

## 1. HOW TO INSTALL THE SYSTEM

### **How to install the display unit in a console**

**Note 1:** Requires Flush Mount Kit OP03-228 (Option).

**Note 2:** The unit must be installed in a flat area of the console. Ensure there is ample room behind the unit once installed to allow access for maintenance.

Follow the procedure shown below to install the display unit in a console.

1. Prepare a hole in the installation location referring to the outline drawing at the back of this manual.
2. Unfasten the knob bolts and remove the display unit from the hanger.

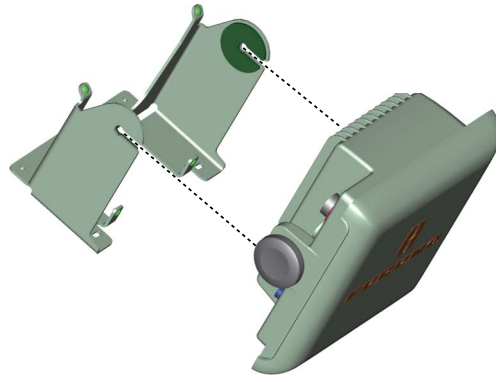

3. Fit the backing sponges, referring to the diagram below.

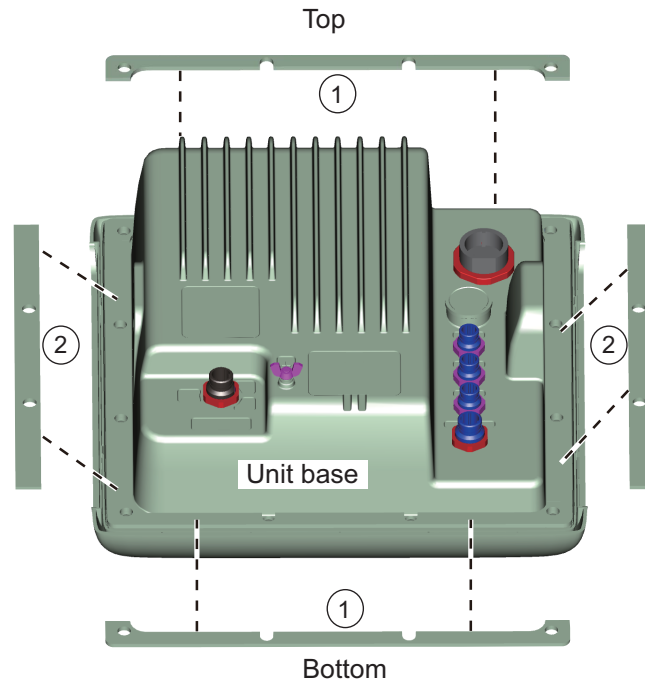

**Note 1:** Ensure the backing sponges are used correctly. 1 - Horizontal, 2 - Vertical.

**Note 2:** Take care to place the backing sponges around screw holes and ensure there are no gaps between the sponges at their joining points.

4. Connect all necessary cables to the unit, making sure to leave enough slack for maintenance and service.
5. Insert the unit into the console, making sure that all cabling attached to the unit is not damaged. Ensure the unit is secure before proceeding to the next step.



6. Adjust the flush-mounting fixture by loosening the wingnuts and wingscrews to allow the bolt free movement. Use the figure below for reference.

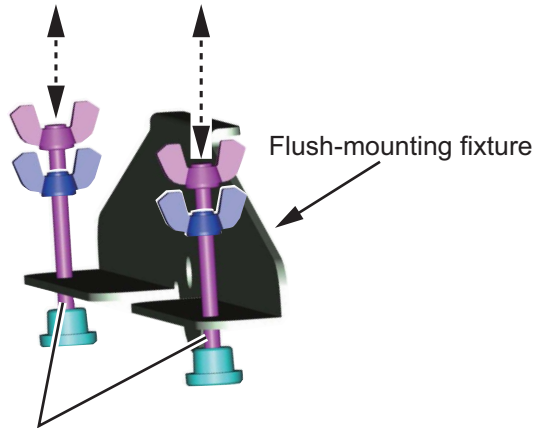

7. Attach the flush-mounting fixture to the unit referring to the diagram below.

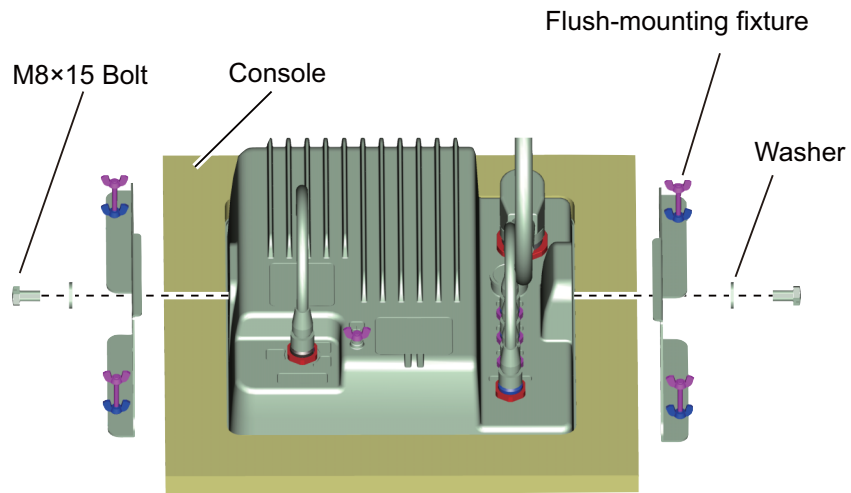

8. Fasten the four wingscrews until the footing is flush against the mounting area. See No. 2 in the figure below for reference.

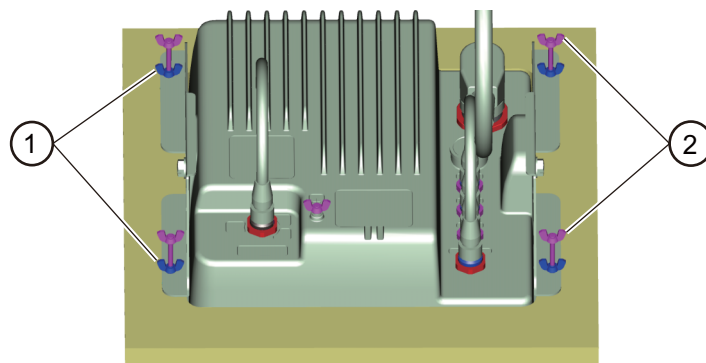

9. Tighten the four wingnuts until the unit is firmly secured. See No. 1 in the figure above for reference.

## 1.2 Antenna Unit Installation

### How to select the location for the antenna unit

- The antenna unit is installed either on top of the wheelhouse or a platform on the radar mast. Install the antenna unit where there is a good complete view. Any obstruction causes blind sectors. For example, a mast with a diameter smaller than the horizontal beamwidth of the radiator causes only a small blind sector. A horizontal spreader or crosstrees in the same horizontal plane creates a large obstruction. Install the antenna unit above, or below a horizontal spreader or crosstrees.
- You cannot put the antenna unit where there is a completely clear view in all directions. Make sure you check for blind sectors on the radar screen after you have installed the radar.
- To reduce the electrical interference, do not run the signal cable near other electrical equipment. Also do not run the cable in parallel to power cables.
- A magnetic compass gives error if the antenna unit is installed near the magnetic compass. See SAFETY INSTRUCTIONS for the compass safe distances to prevent the interference to a magnetic compass.
- Do not apply paint to the radiator aperture. The radar wave cannot be transmitted if there is paint on the radiator.
- If this radar is installed on a large vessel, follow the points shown below:
  - The length of the signal cable between the antenna unit and the display unit is max. 30 m.
  - The output from a funnel or exhaust vent decreases aerial performance and hot gases can damage the radiator. The antenna unit must not be installed where the temperature is more than 55°C.
- The antenna unit can be installed on the bridge, a common mast, or the radar mast.

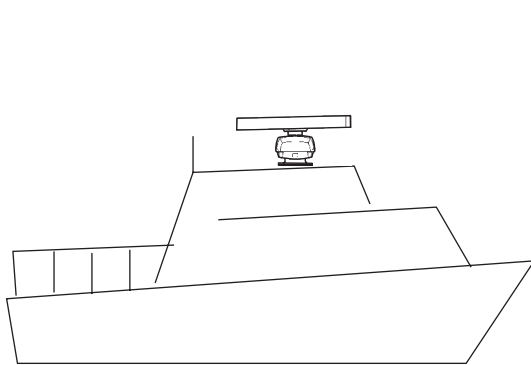

(a) On bridge

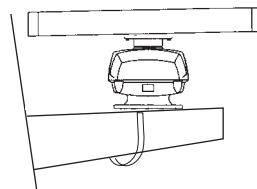

(b) Common mast

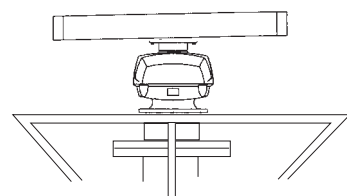

(c) Radar mast

## 1.2.1 Installation procedure

Refer to the outline drawing at the back of this manual for the dimensions. Make five holes in the platform. Four holes to fasten the antenna unit and one hole for the signal cable.

### How to fasten the radiator to the chassis

See the packing list at the back of this manual for the installation materials.

1. Remove the radiator cap from the radiator bracket.
2. Apply marine sealant to the surface of the antenna radiator and the radiator bracket. See the figure shown below for the location.

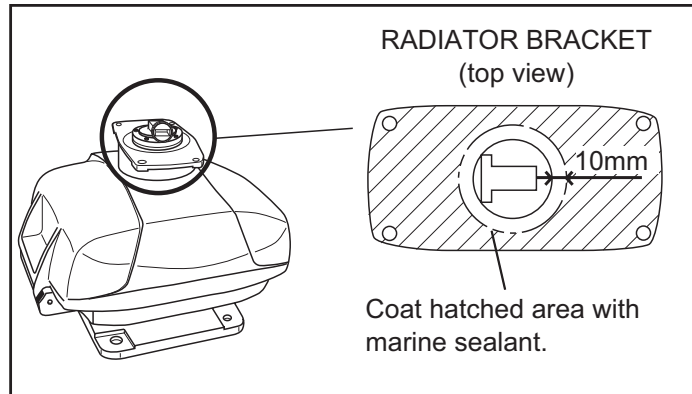

3. Apply the marine sealant to the threads in the four holes on the antenna radiator.
4. Apply the grease to the O-ring and set the O-ring to the radiator bracket.
5. Set the antenna radiator on the radiator bracket.
6. Apply the marine sealant to the radiator bolts (4 pieces). Fasten the antenna radiator to the radiator bracket with the radiator bolts, flat washers and spring washers.

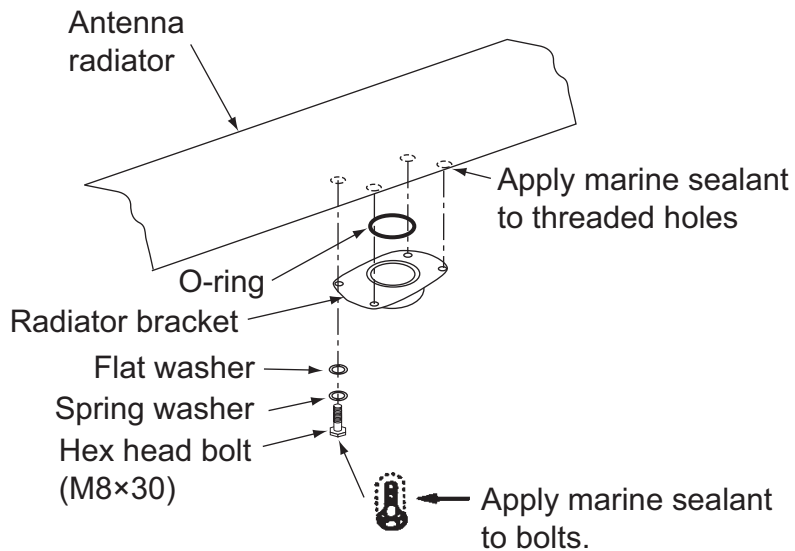

## 1. HOW TO INSTALL THE SYSTEM

### 1.2.2 How to install the antenna unit

You can install the antenna unit by one of the two methods shown below.

- Use the outside holes
- Use the inside holes

#### **How to use outside holes of the antenna housing**

Use the hex head bolts (supplied) to install the antenna unit as shown in the illustration below.

1. Put the rubber mat (supplied) on the platform.

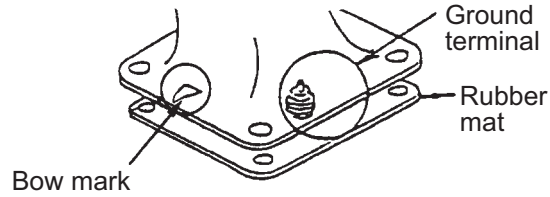

2. Put the antenna unit on the rubber mat. Align the position of the antenna unit as shown in the illustration below.

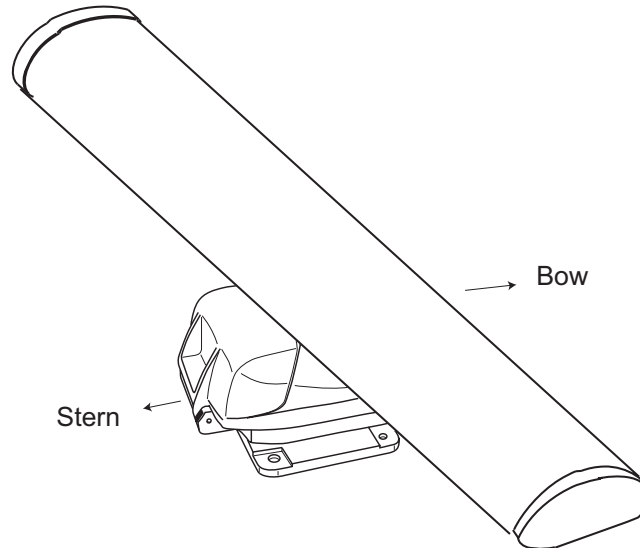
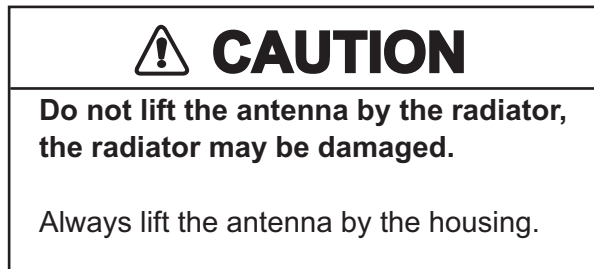

- Set four hex head bolts (M12×60, supplied) and seal washers (supplied) from the top of the antenna housing, as shown below.

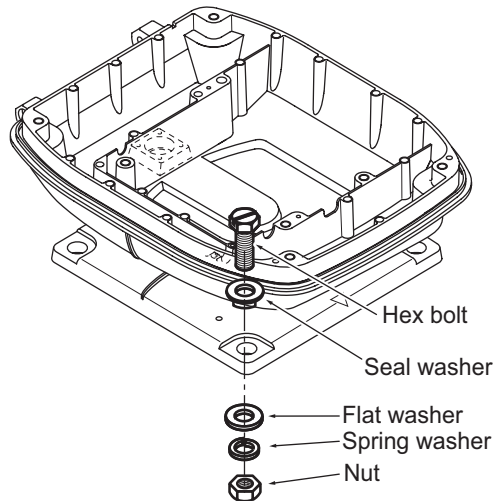

- Set the flat washers (M12, supplied), spring washers (supplied) and nuts (supplied) to the hex head bolts. Tighten by turning the nuts. Do not tighten by turning the hex head bolts, to prevent damage to the seal washers.

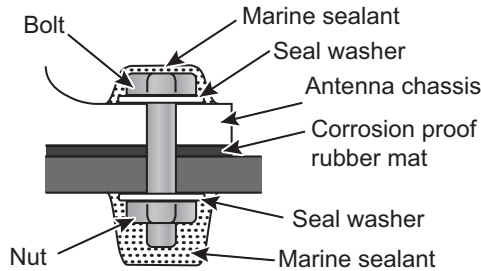

- Apply anti-corrosive sealant to the flat washers, spring washers, nuts and visible parts of bolts.
- Prepare the ground point on the platform. Use an M6×25 bolt, nut and flat washer (supplied). The ground point must be within 300 mm from the ground terminal on the antenna unit.
- Run the ground wire (RW-4747, 340 mm, supplied) between the ground terminal and the ground point.
- Apply marine sealant to the ground terminal and ground point as shown below.

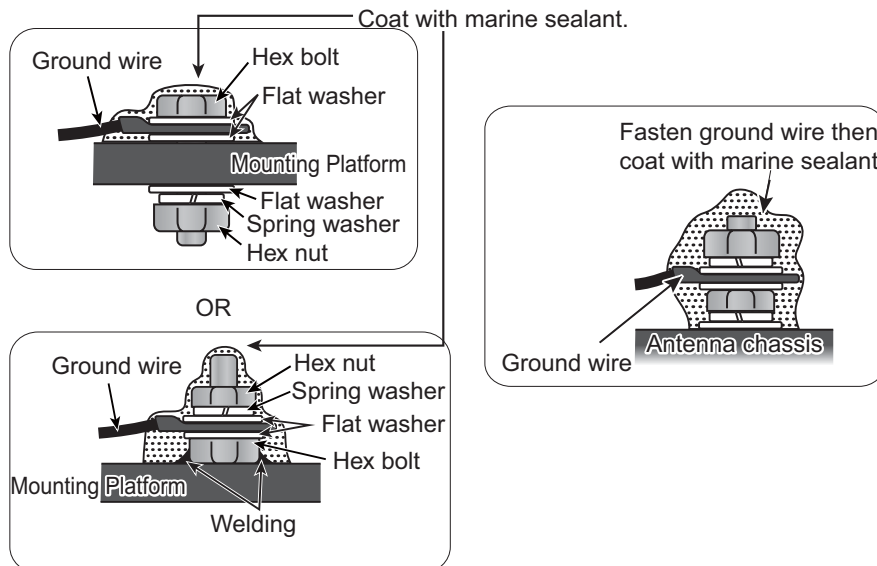

## 1. HOW TO INSTALL THE SYSTEM

### 1.2.3 How to use the inside holes of the antenna housing (FR-8045)

This method requires removal of the RF unit from the antenna unit to access the inside fixing holes. Use four hex head bolts, flat washers, spring washers and nuts (local supply) to install the antenna unit. Check the length of the bolts before you install.

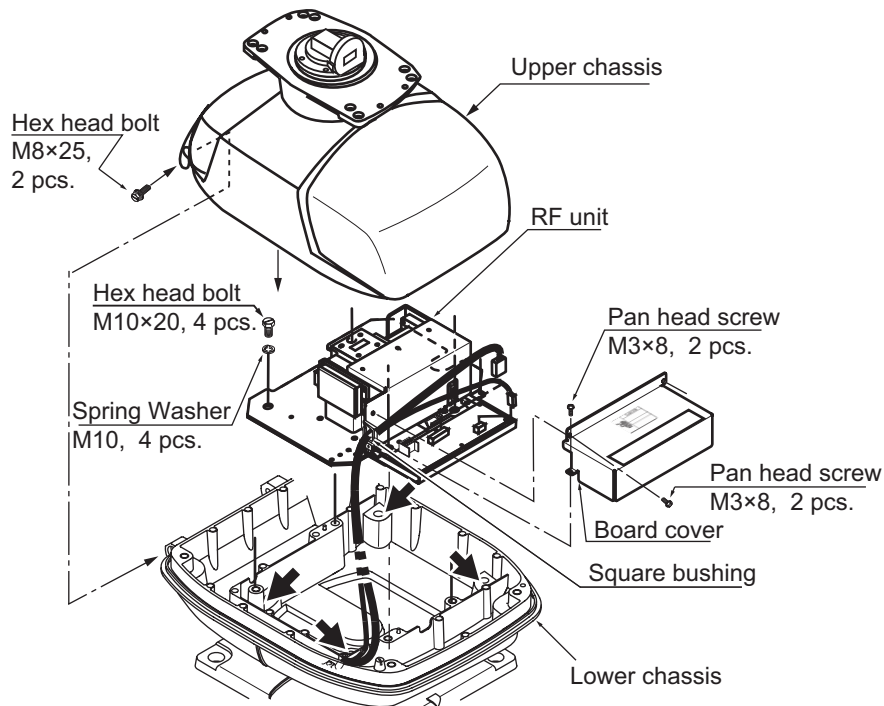

*Antenna unit chassis, upper chassis separated*

1. Unfasten four bolts on the cover to open the antenna unit.
2. Disconnect the connectors connected between the upper chassis and the lower chassis.
3. Remove two hex head bolts (M8×25) to separate the upper chassis from the lower chassis.
4. Loosen four pan head screws to remove the cover from the pc board.
5. Remove the connector from the RF unit.
6. Loosen four hex head bolts to remove the RF unit.
7. Set the corrosion-proof rubber mat (supplied) to the support platform.
8. Cut the rubber bushings in the fixing holes and put four bolts from the inside of the lower chassis. Fasten the lower chassis to the support platform with the spring washers, flat washers and nuts (local supply). Apply marine sealant to the flat washers, nuts and visible parts of bolts.
9. Assemble the RF unit, cover and chassis.
10. Set four caps (supplied) into the outside fixing holes.
11. Prepare the ground point on the platform. Use an M6×25 bolt, nut and flat washer (supplied). The ground point must be within 300 mm from the ground terminal on the antenna unit.
12. Run the ground wire (RW-4747, 340 mm, supplied) between the ground terminal and the ground point.
13. Apply the marine sealant to the ground terminal and ground point. See the illustration on page 8 for instructions.

### 1.2.4 How to connect the signal cable (FR-8045)

The signal cable runs from the display unit to the antenna unit. To reduce the electrical interference, do not run the signal cable near other electrical equipment. Also do not run the cable in parallel to power cables. Put the cable through the hole and apply sealing compound around the hole for waterproofing.

1. Loosen four bolts, open the antenna cover, and set the stay.

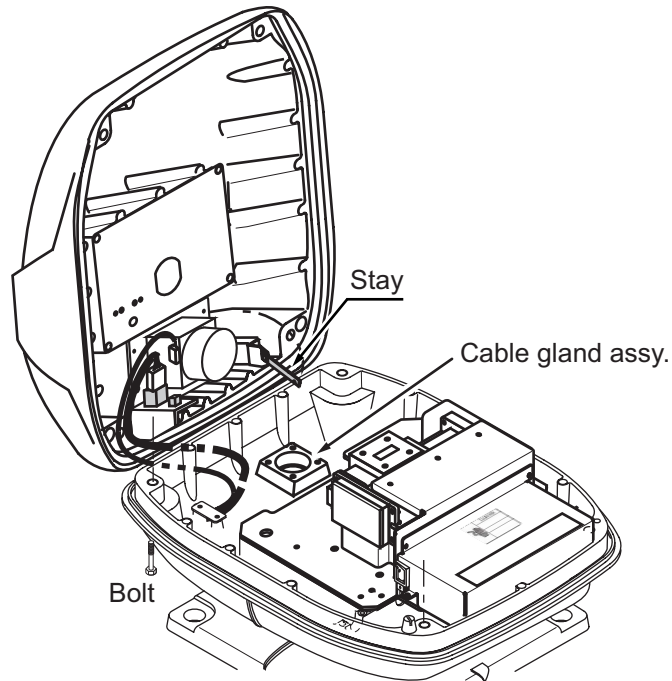

2. Loosen the cable gland assembly (plate, gasket, flat washer).
3. Put the signal cable with the connector through the bottom of the antenna unit chassis. Put the cable through the gland assembly as shown below.

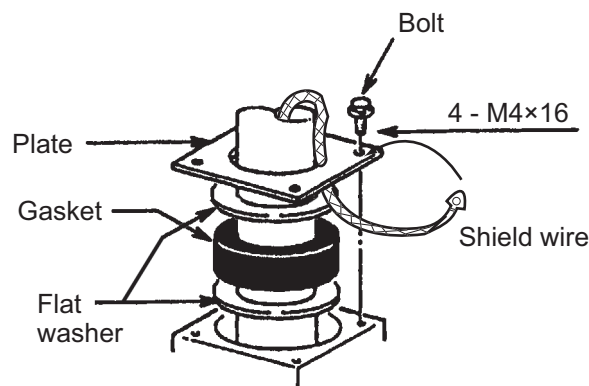

4. Fasten the crimp-on lug of the shield wire to one of the four fixing bolts of the cable gland assembly.

## 1. HOW TO INSTALL THE SYSTEM

- Put the signal cable so that no more than 4 cm of the sheath is visible, as shown in the figure below. Tighten the fixing bolts.

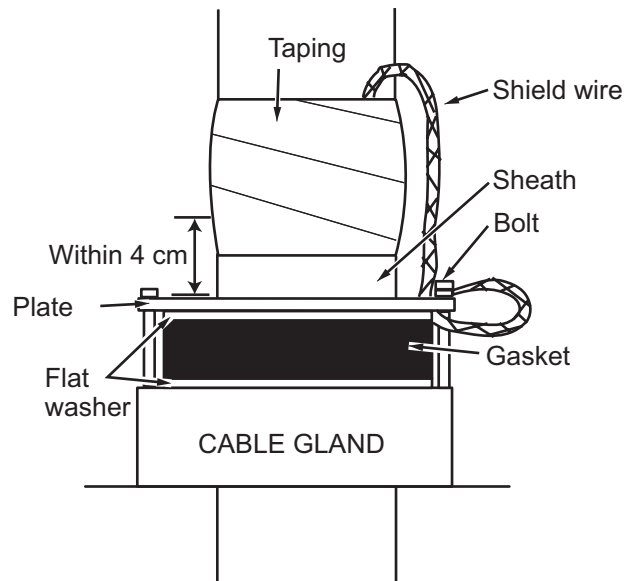

- Loosen four screws in the figure shown below and open the cover.

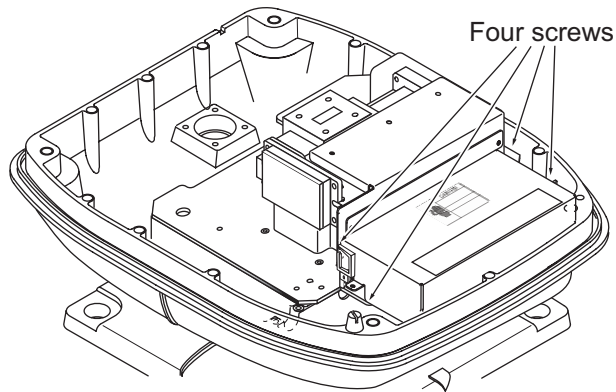

- Put the signal cable through the cable protector.

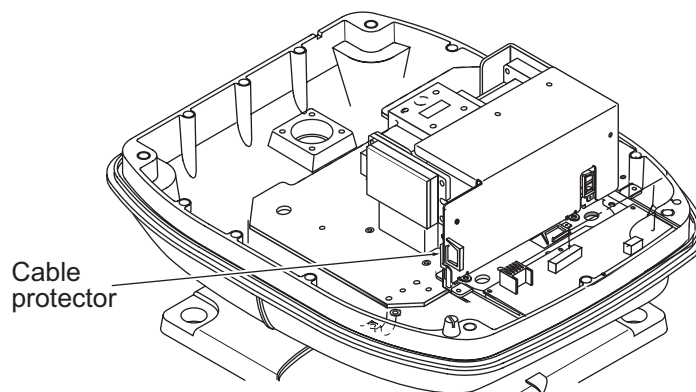

- Connect the signal cable to the RTB Board (03P9249). See the interconnection diagram and the figure shown on page 12.



9. Attach three EMI cores to the signal cable as shown below.

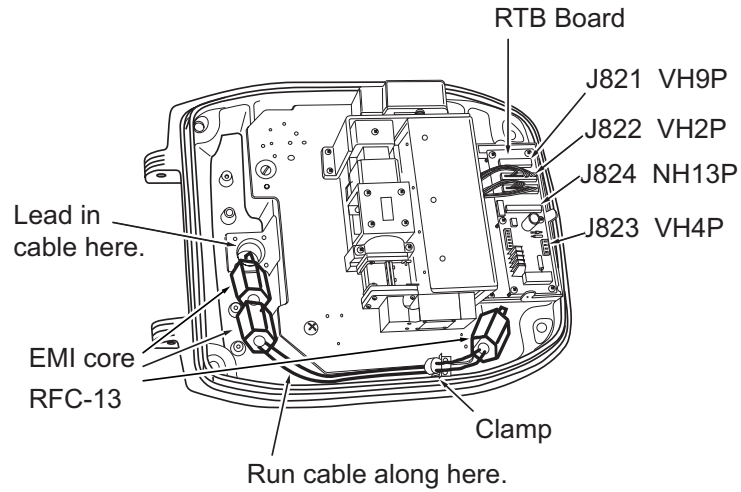

10. Fasten the signal cable with the cable clamp.

11. Undo the stay and close the cover. Securely fasten the scanner bolts.

**Note:** When you close the cover, set the gaskets to the grooves in the bottom chassis, then tighten the bolts.

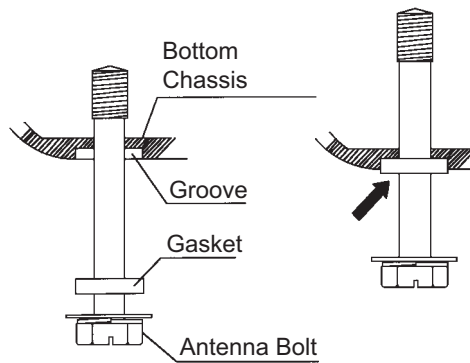

Torque :  $9.8 \pm 0.1$  Nm

## 1. HOW TO INSTALL THE SYSTEM

### 1.2.5 How to use the inside holes of the antenna housing (FR-8065/FR-8125/FR-8255)

This method requires removal of the RF unit in the antenna unit to access inside fixing holes. Use hex head bolts, flat washers, spring washers and nuts (local supply) to mount the antenna unit, confirming length of bolts.

1. Unfasten four antenna bolts on the cover to open the antenna unit.
2. Unfasten four screws on the RTB cover to remove it.
3. Unplug connector J827 and J834 on the RTB board
4. Separate upper chassis from lower chassis by removing two hex head bolts (M8x25).
5. Remove RF unit by unfastening four hex head bolts.

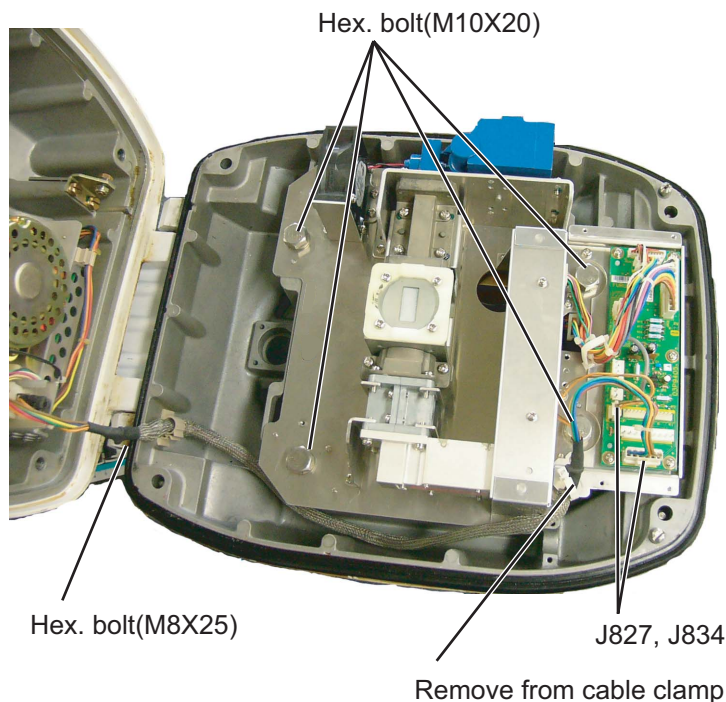

#### *Antenna unit, opened*

6. Lay the corrosion-proof rubber mat (supplied) on the mounting platform.
7. Fasten the lower chassis to the mounting platform with hex head bolts, spring washers, flat washers and nuts (local supply), and then coat flat washers, nuts and exposed parts of bolts with marine sealant. Cut a slit in the rubber bushing and insert bolt into the bushing. Do not use seal washers.
8. Reassemble RF unit, cover and chassis.
9. Set four knob caps (supplied) into outside fixing holes.
10. Do steps 6-8 in "Outside fixing holes" on page 8.

## 1.2.6 How to connect the signal cable (FR-8065/FR-8125/FR-8255)

Only the signal cable runs from the display unit (power supply unit in case of FR-8255) to the antenna unit. In order to minimize the chance of picking up electrical interference, avoid where possible routing the signal cable near other onboard electrical equipment. Also, avoid running the cable in parallel with power cables. Pass the cable through the hole and apply sealing compound around the hole for waterproofing.

### Fabricating the signal cable

This type of signal cable is used with other models of radar. For these models, the following fabrication is required.

1. Remove shrink tubing from the signal cable.

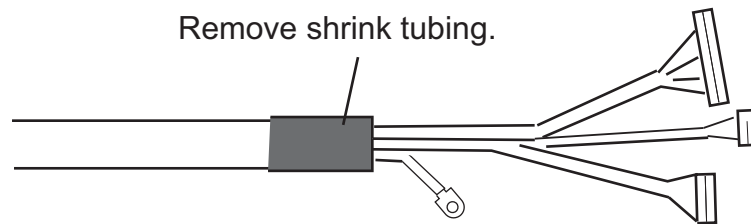

2. Remove vinyl sheath approx. 50 mm.

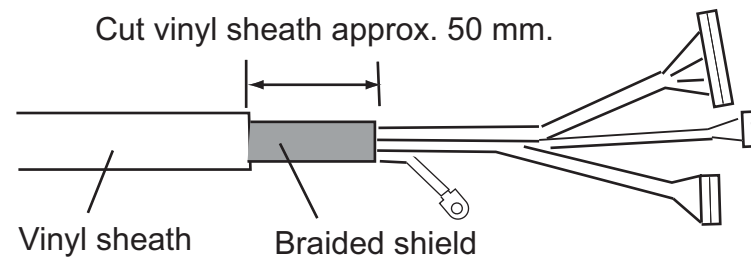

3. Wrap vinyl tape at the end of the vinyl sheath.

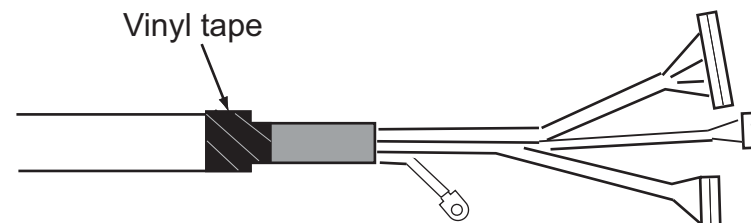

## 1. HOW TO INSTALL THE SYSTEM

### **Connecting the signal cable**

1. Open the antenna cover by loosening four bolts, and then fix the stay.

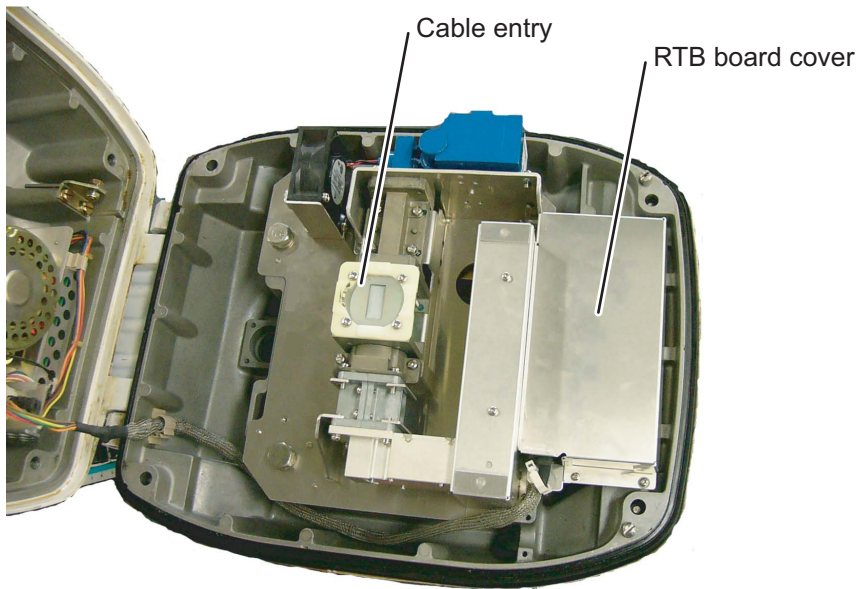

*Antenna unit chassis, cover opened*

2. Unfasten the cable gland assembly (plate, gasket, flat washer). The plate may be discarded.
3. Pass the signal cable with connector through the bottom of the antenna unit chassis. Pass the cable through the gland assembly as shown below.

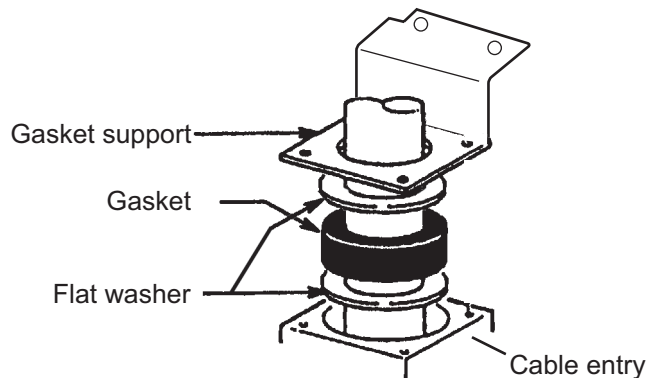

*Passing the signal cable through the cable gland assembly*

4. Fasten the gasket support with four bolts. Using one of the four bolts, fasten the crimp-on lug to the shield wire.

5. Fasten the shielded part of the signal cable with shield clamp (installation material) as shown below.

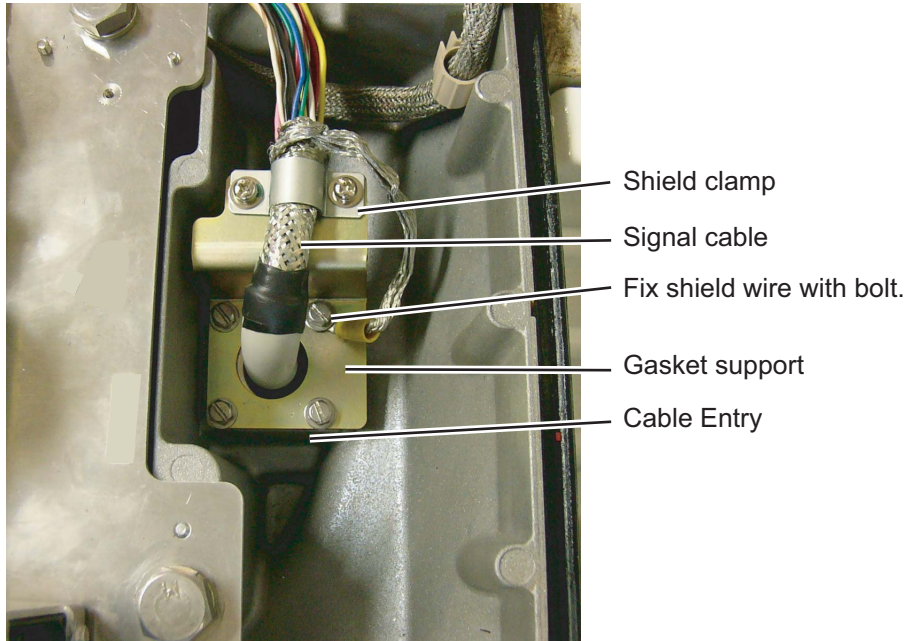

*How to fix signal cable in cable gland*

6. Unfasten four screws to remove the RTB board cover.
7. Connect the plugs of the signal cable to the RTB board.

FR-8065, FR8125 : J821, J823, J824, J822

FR-8255 : J821, J823, J824, J820

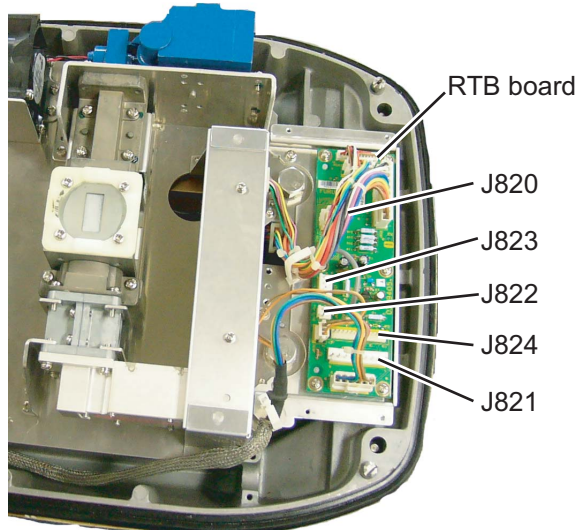

*Connecting to the RTB board*

8. Reattach the RTB board cover.

1. HOW TO INSTALL THE SYSTEM

9. Attach three EMI cores to the signal cable as shown below.

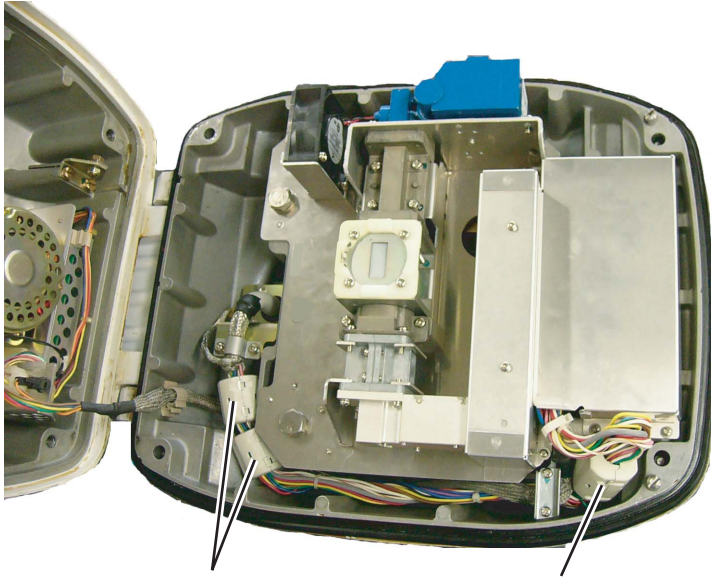

EMI Core RFC-13 (2 pcs) EMI Core RFC-H13 (1 pc)

*Antenna unit chassis, cover opened*

10. Fix the signal cable with the cable clamp as follows.  
a) Dismount the cable clamp plate and remove clamp and gasket.

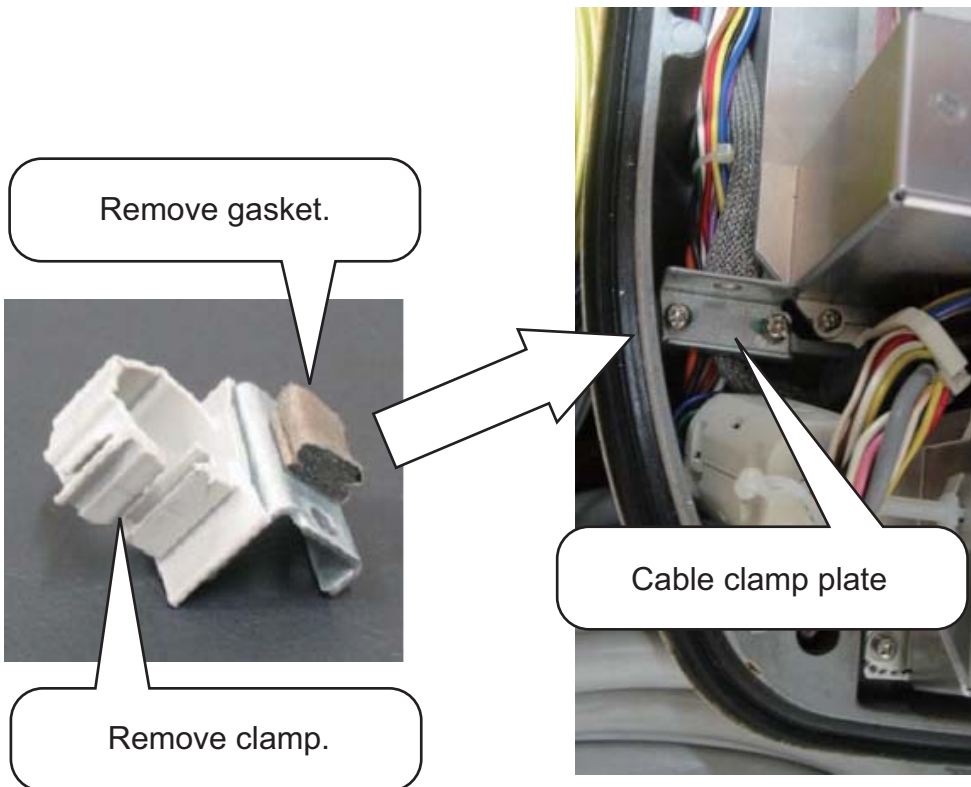

b) Run the signal cable as shown below.

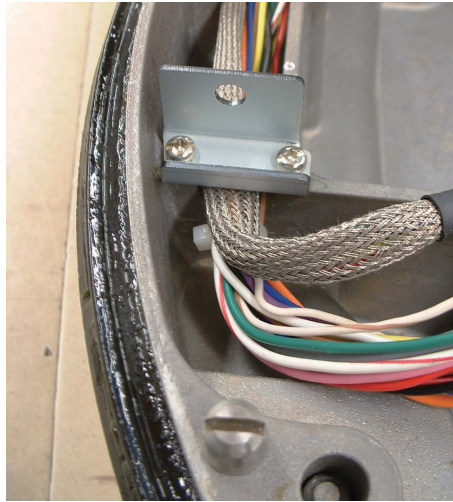

c) Fix the signal cable with cable clamp as shown below.

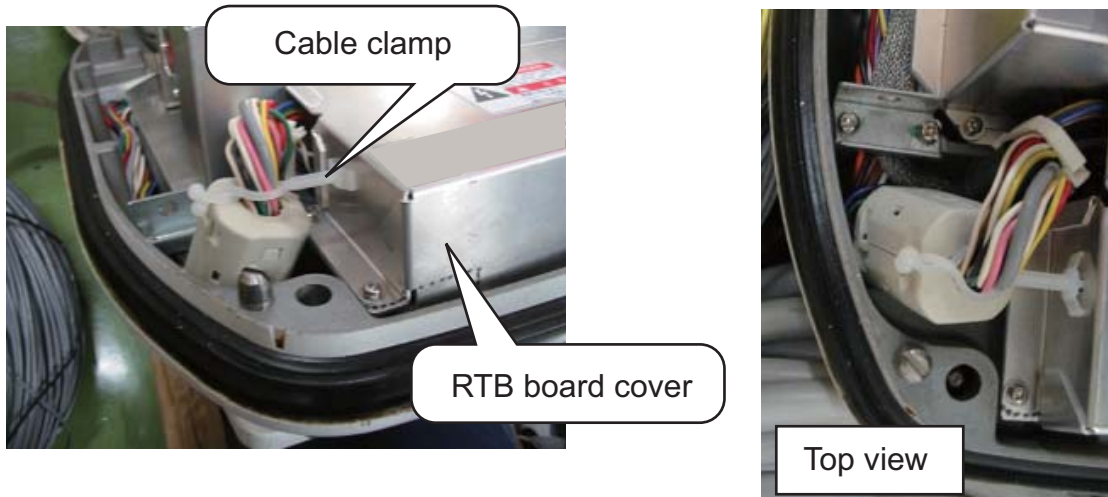

11. Release the stay and close the cover. Loosely fasten the antenna bolts; you will have to make some adjustments inside after completion of wiring.

**Note:** When you close the cover, set the gaskets to the grooves in the bottom chassis, then tighten the bolts.

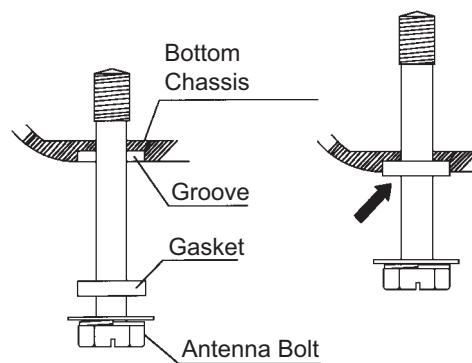

Torque :  $9.8 \pm 0.1$  Nm

### 1.3 Power Supply Unit

A power supply unit is shipped with the FR-8255, because of its high power consumption.

The power supply unit can be installed almost anywhere provided the location is dry, well-ventilated, sufficient maintenance space is provided and is installed within 5 m (cable length) from the display unit. To fix the unit, use four self-tapping screws (5x20).

**Note:** Do not install the power supply unit on the overhead; install it on the deck or bulkhead.

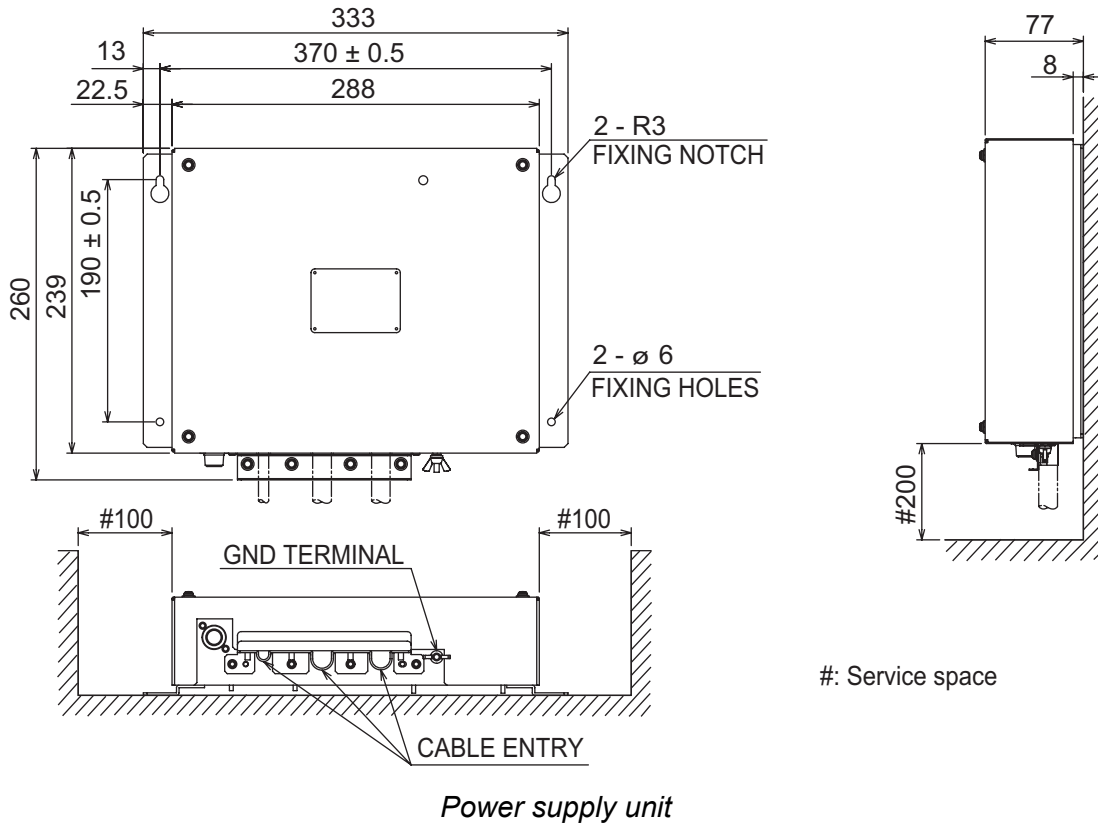



## 2. CABLE CONNECTION AND WIRING

### 2.1 Standard Connection

Connect all necessary cables, using the figure and table below for reference.

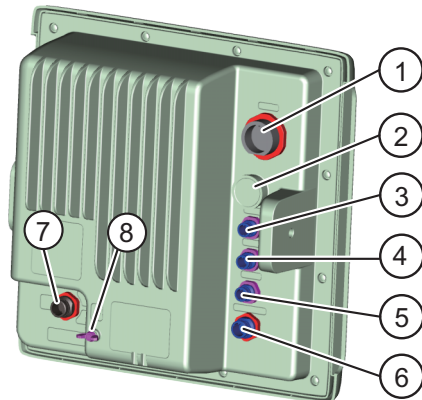

No.	Description	Cable Required
1	Antenna cable to antenna unit (FR-8045)	MJ-B24LPF0005- <sup>*</sup> +R <sup>*</sup> : 50/100/150/200/300
	Antenna cable to antenna unit. (FR-8065/8125)	MJ-B24LPF0012- <sup>*</sup> +R <sup>*</sup> : 100/150/200/300
	Antenna cable to antenna unit. (FR-8255)	<ul style="list-style-type: none"> <li>• MJ-B24LPF0011-050+R</li> <li>• RW-9771 (10m, 15m, 20m, 30m)</li> <li>• VL3P-VV-S2X2C-AA050</li> </ul>
2	USB (Used by service man only).	
3	Heading Sensor. (AD-10 format)	(MJ-A6SPF0007-100C)
4	NMEA1 input/output. (Navigational equipment)	(MJ-A7SPF0007-050C)
5	NMEA2 input/output. (Navigational equipment)	(MJ-A7SPF0007-050C)
6	Option. (External buzzer, Remote display)	(See section 4.2 for cabling.)
7	Power in. To ship's power (pos = white, neg = black)	(MJ-A3SPF0017-050ZC)
8	Grounding. Connect from here to ship's terminal.	IV-2sq.

## 2.2 Wiring the Power Supply Unit (FR-8255 only)

### 2.2.1 Cabling

1. Unfasten four screws to remove the cable clamp.
2. Unfasten four screws to remove the cover.
3. Attach the connectors of three cables as shown in the figure below.

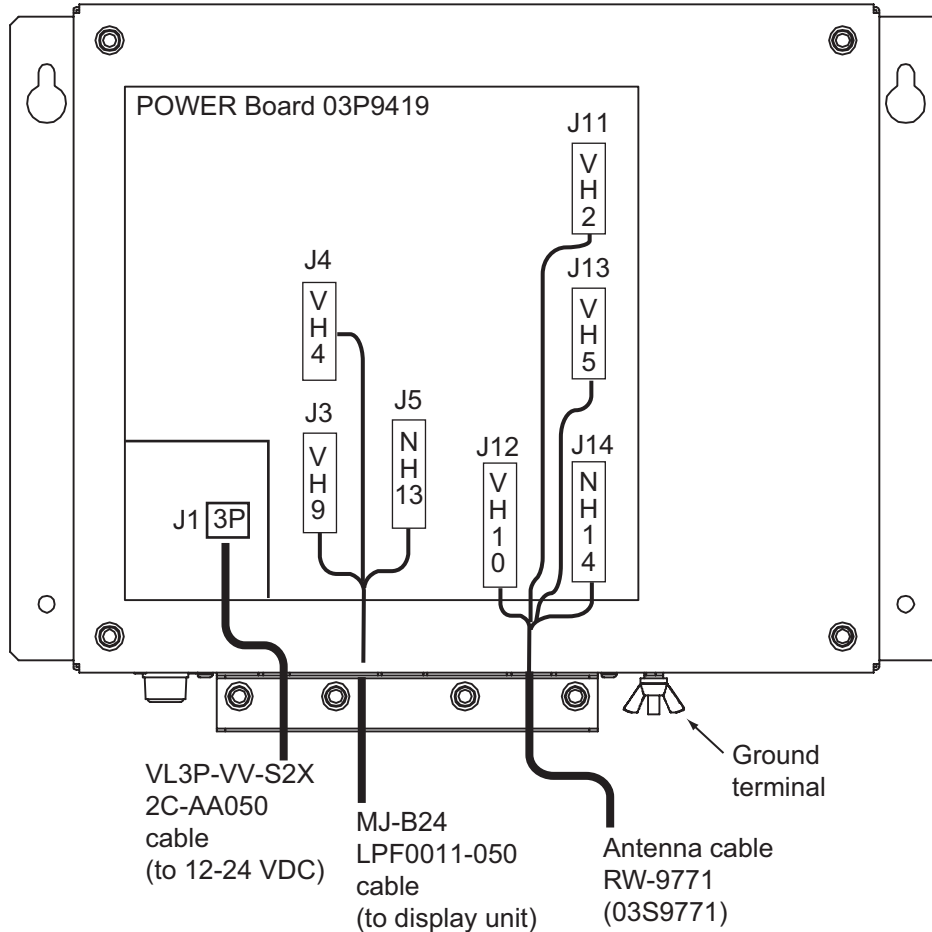

4. Lay three cables in respective slots referring to the figure above.
5. Reattach the cover and the cable clamp.
6. Connect a ground wire (local supply, IV-2sq) between the ground terminal and ship's ground.

### 2.2.2 Jumper block, slide switch setting

The jumper block JP1 and slide switch S112 on the PWR board (03P9419) must be set according to radar model. Open the unit, locate JP1 and S112 and set them as below.

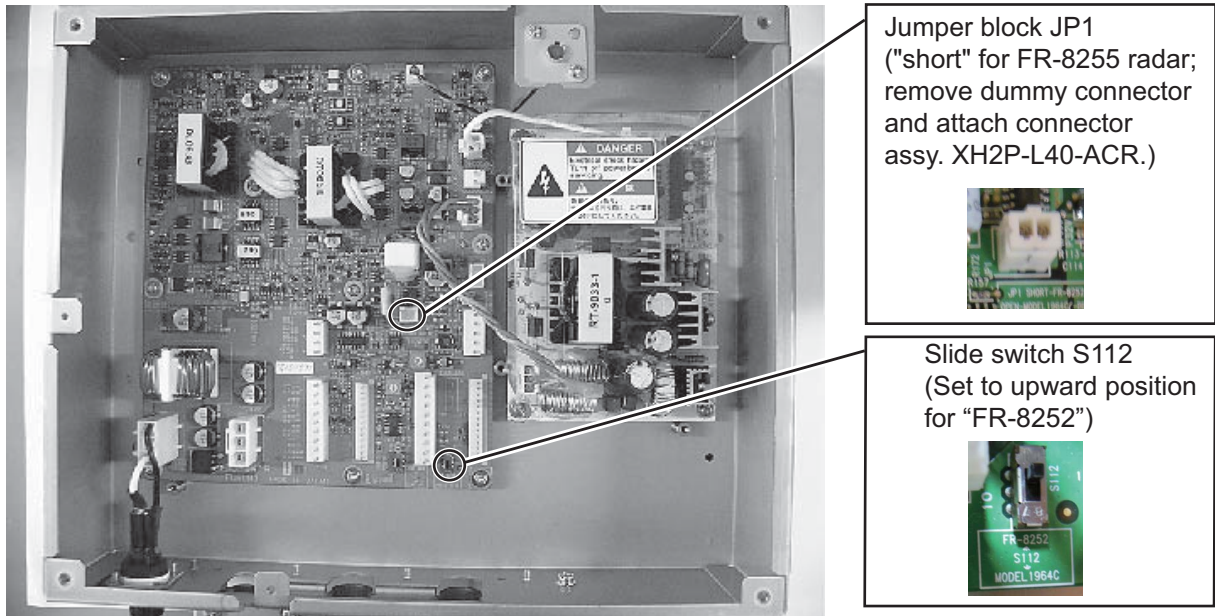

Jumperblock, slide switch	Function	Setting
JP1	Enables/disables motor slow start circuit.	Short (disable)
S112	TUNE voltage selector (0-12 V, 0-32 V)	Upward position (0-12 V)

### 2.2.3 Power requirement, replacement of fuses

#### Power requirement

The power for the power supply unit and display unit must be drawn from the same power switch on the power terminal board.

#### Replacement of fuses

The power supply unit is shipped with a 15 A fuse(for connection to 12 VDC battery). Replace the fuse with a 7 A (supplied) when the ship's battery is 24 VDC.

## 2.3 Data Signals

Position	GNS>GGA>RMC> GLL
Course true	VTG>RMC
Course magnetic	VTG>RMC (true)
Speed over the ground	VTG>RMC
Water speed and heading	VHW
Distance to waypoint	BWR>BWC>RMB
Destination waypoint, true	BWR>BWC>RMB
Destination waypoint, magnetic	BWR>BWC
Heading (true)	THS>HDT>VHW (true)>HDG>HDM>VHW (magnetic)
Heading (magnetic)	HDG> HDM>VHW (magnetic)THS>HDT>VHW (true)
Magnetic variation	HDG>RMC
Cross-track error	XTE>RMB
Depth	DPT>DBT
Temperature	MTW
Wind (true)	MWV>VWT
Wind (relative)	MWV>VWR
Time	ZDA

## 2.4 Input/Output Ports

### 2.4.1 HDG port

This port is for AD-10 format.

Parameter	Rating	Remarks	Circuit Diagram
Forward Current	50mA	Absolute Maximum	<p>The diagram shows a circuit for the HDG port. It features a 490Ω resistor connected between the input terminal GYRO_DATA_H and a diode. The diode is oriented with its cathode towards the input. The other terminal of the diode is connected to the input terminal GYRO_DATA_C. The output of the diode is connected to a Photocoupler.</p>
Reverse Voltage	6V	Absolute Maximum	
Forward Voltage	1.1V (TYP) 1.4V (MAX)	$I_F=4mA$	
Parameter	Rating	Remarks	Circuit Diagram
Forward Current	50mA	Absolute Maximum	<p>The diagram shows a circuit for the HDG port. It features a 490Ω resistor connected between the input terminal GYRO_CLK_H and a diode. The diode is oriented with its cathode towards the input. The other terminal of the diode is connected to the input terminal GYRO_CLK_C. The output of the diode is connected to a Photocoupler.</p>
Reverse Voltage	6V	Absolute Maximum	
Forward Voltage	1.1V (TYP) 1.4V (MAX)	$I_F=4mA$	

## 2.4.2 NMEA1 ports

### Transmitter

This port complies with “IEC 61162-1 Ed4”.

Parameter	Rating	Remarks	Circuit Diagram
“H” level output current	-60mA	Absolute Maximum	
“L” level output current	60mA	Absolute Maximum	
Differential output voltage	1.5V (MIN) 5V (MAX)	Load 54Ω	

### Receiver

This port complies with “IEC 61162-1 Ed4”.

Parameter	Rating	Remarks	Circuit Diagram
Forward Current	50mA	Absolute Maximum	
Reverse Voltage	6V	Absolute Maximum	
Forward Voltage	1.1V (TYP) 1.4V (MAX)	$I_F=4mA$	

## 2.4.3 NMEA2 ports

This port complies with “IEC 61162-1 Ed4”.

Circuit specification is the same as NMEA1 port.

# 3. EQUIPMENT SETTINGS

## 3.1 Setting the Language

After installation, on first power-up, select a language as follows:

1. Press the  /**BRILL** key to turn on the power.

"Now Initializing" appears and after a short time the window below appears.

Language	English
Langue	Français
Idioma	Español
Sprache	Deutsch
Lingua	Italiano
Idioma	Português
Sprog	Dansk
Språk	Svenska
Språk	Norsk
Kieli	Suomi
Γλώσσα	Ελληνικά
语言	中文
言語	日本語
ភាសា	ភាសា ខ្មែរ
언어	한국어
Язык	Русский

2. Use the **CursorPad** to select a language required and press the **ENTER** key. The window shown below appears.

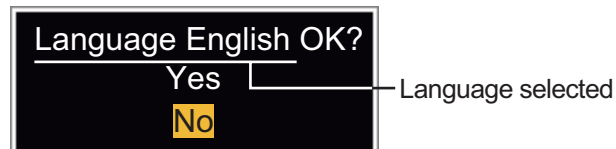

3. Select [Yes] and press the **ENTER** key.

## 3.2 How to Set the Purpose

1. Press the **MENU** key. The main menu will appear on the screen.
2. Press the **▲** or **▼** button to select [Factory]. The factory menu title bar will appear in gray color right side of the screen.
3. Hold down the **CANCEL/HL OFF** key and press the **MENU** key five times to activate the [Factory] menu.

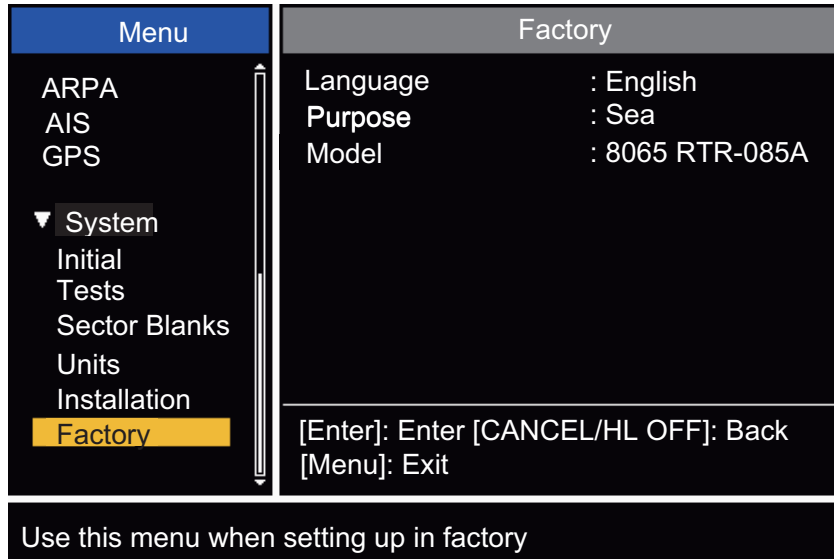

4. Press the **ENTER** key. The [Factory] menu becomes active and the cursor moves to the right-hand column.
5. Press **▲** or **▼** to select [Purpose].
6. Press the **ENTER** key to show the setting window.



7. Press **▲** or **▼** to select the purpose required.
8. Press the **ENTER** key to set the purpose.
9. Press **▼** to select [Model].
10. Press the **ENTER** key to show the setting window. The default setting is [8065 RTR-085A].  
**Note:** For FR-8045, the default is [8045 RTR-088A]. No adjustment is necessary, go to step 13.



11. Press **▲** or **▼** to select the appropriate model.
12. Press the **ENTER** key to set the model.
13. Press the **CANCEL/HL OFF** key to return to the main menu.

### 3.3 How to Enter Initial Settings

After you complete setting the radar purpose, enter the Initial Settings as follows:

1. On the main menu, press ▲ or ▼ to select [Installation].

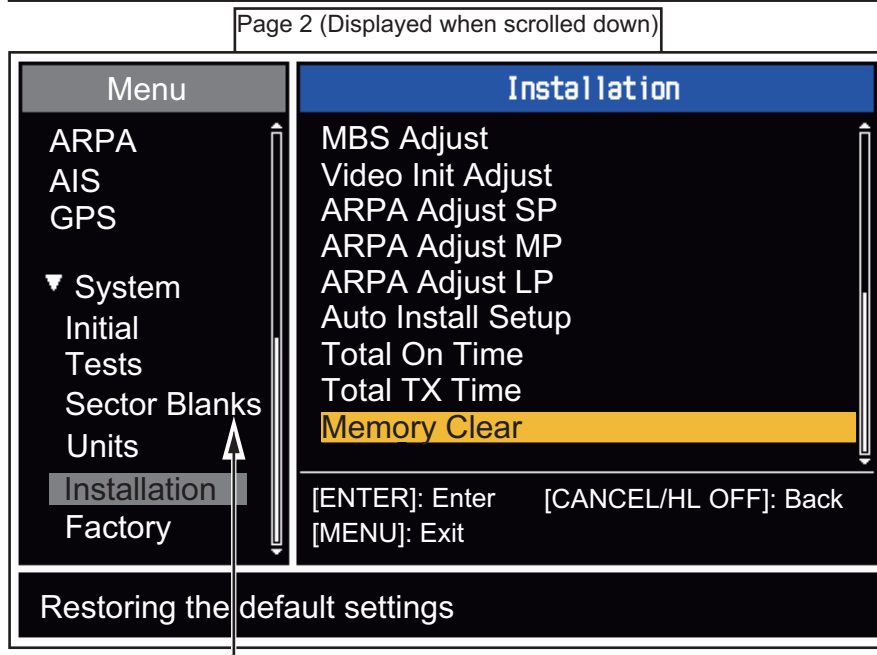
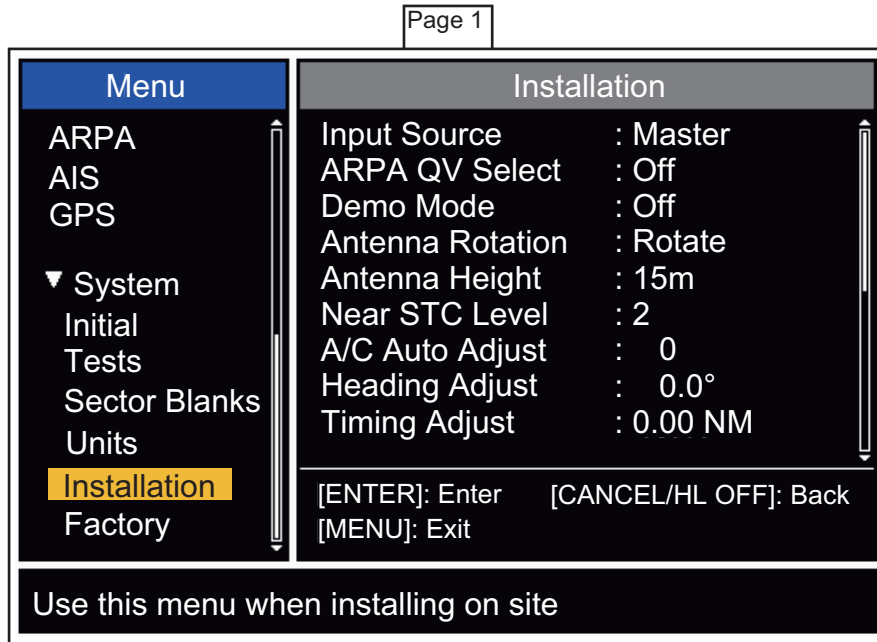

Set the [Sector Blank] to [Off] in order to execute [Auto Installation Setup] in the [Installation] menu.

2. Press the **ENTER** key. The [Installation] menu becomes active and the cursor moves to the right-hand column.
3. Press ▲ or ▼ to select an item from the [Installation] menu.
4. Press the **ENTER** key to show the settings window.
5. Press ▲ or ▼ to select an option.
6. Press the **ENTER** key to set the option.
7. Press the **MENU** key to close the main menu.



**Basic settings**

**[Input source]:** Select the input source from [Master] and [Slave]. The default setting is [Master].

**Master** The display unit operates as the main radar.

**Slave** The display unit operates as a remote display. For remote displays, adjust the [Video Init Adjust] and [Timing Adjust].  
(See page 30 and page 29, respectively.)

**[ARPA QV Select]:** Set to [On] to display quantized video on the screen. Set to [Off] for normal use.

**[Demo Mode]:** Set to [On] to active demo mode. Set to [Off] for normal use.

**[Antenna Rotation]:** [Rotate] (default setting) transmits the radar pulses by rotating the antenna. [Stop] transmits the radar pulses without rotating the antenna.

**[Antenna Height]:** Set the height of the antenna above the water surface. The options are 5, 10, 15, 20, 30, 40 and 50m. The default setting is 15m.

**[Near STC level]:** Set the STC curve to a near distance. The options are 1, 2, 3 and 4. "4" has the strongest effect.

**[A/C Auto Adjust]:** Adjust the performance of the automatic A/C.

**[Memory Clear]:** Restore the default settings. [Purpose], [Type] and [Source] are not changed. When turning on the power after a memory clear, the language selection window appears. (See page 25.)

**Heading adjustment**

Ensure you have installed the antenna unit correctly, so that the unit faces towards the bow of the ship. A target at the front of the ship, aligned with the bow, must appear on the heading line (zero degrees). If the target does not appear on the heading line, follow the procedure below to adjust the heading.

1. Set the ship toward an acceptable target (for example, a ship at anchor or a buoy) at a range between 0.125 and 0.25 nautical miles.
2. Transmit the radar at a range setting of 0.25 nautical miles and measure the bearing of that target relative to the ship using an EBL.
3. Open the [Installation] menu and select [Heading Adjust].
4. Press the **ENTER** key to show the setting window for [Heading Adjust]. (See figure below)

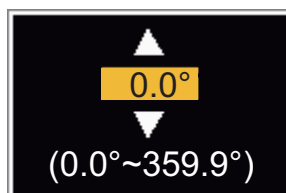

5. Press ▲ or ▼ to set the value measured in step 2. Check that the target appears on the heading line. If necessary repeat steps 1 to 5.
6. Press **ENTER** to complete the adjustment.

### 3. EQUIPMENT SETTINGS

#### **How to automatically set the equipment**

The equipment can automatically adjust the tuning, timing and video.

**Note:** Before you proceed, transmit the radar for more than 10 minutes on a long range and ensure [Sector Blank] is set to [OFF].

1. Transmit on the maximum range.
2. Select [Auto Install Setup] from the [Installation] menu and press **ENTER**.

The tuning adjustment begins automatically and the message "Tuning adjusting" appears during the tuning adjustment stage. After the tuning adjustment is complete, the timing and video are adjusted, in that order. The messages "Timing adjusting" and "Video adjusting" will appear during those stages of the [Auto Install Setup]. After all the adjustments are completed, the window disappears.

**Note:** If any of the results require adjustment for your conditions, use the manual adjustment procedures below to manually adjust them.

#### **Manual timing adjustment**

This adjustment gives correct radar performance on short ranges. The radar measures the time required for a transmitted echo to go to the target and return to the source. The received echo appears on the display according to the measured time. The sweep must start from the center of the display.

A trigger pulse created in the display unit goes to the antenna unit through the signal cable to activate the transmitter (magnetron). The time taken by the signal to move to the antenna unit changes, according to the length of the signal cable. During this period, the display unit must wait before the radar starts the sweep. When the display unit is not adjusted correctly, the echoes from a straight object will not appear as a straight line. The target appears "pushed" or "pulled" near the picture center. The ranges to objects are also shown at wrong distances. Below are examples of wrong and correct sweep timings.

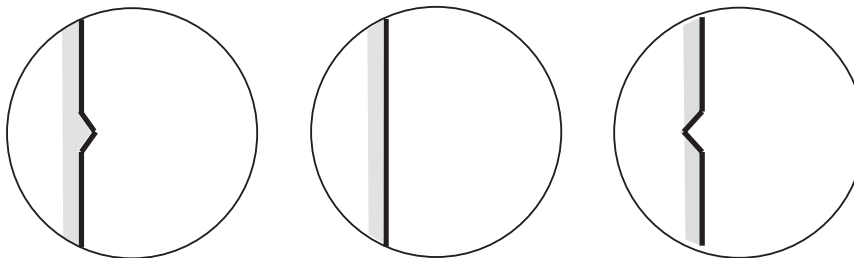

(1) Target pulled

(2) Correct

(3) Target pushed outward

1. Transmit on the shortest range, then adjust the gain and the A/C SEA.
2. Visibly select a target that creates a straight single line, such as harbor walls or straight piers.
3. Open the [Installation] menu and select [Timing Adjust].
4. Press **ENTER** to show the setting window.
5. Press **▲** or **▼** to until the target selected in step 2 is shown as a straight line.
6. Press **ENTER** to complete the adjustments.

**Manual MBS adjustment**

Reduce the main bang (black hole), which appears at the display on short ranges, as follows:

1. Transmit the radar on the shortest range.
2. Open the [Installation] menu and select [MBS Adjust].
3. Press **ENTER** to show the setting window.
4. Use the ▲ or ▼ to adjust the main bang (between 0 and 25).
5. Press **ENTER** to finish.

**Manual video adjustment**

Use the following procedure to manually adjust the video settings if necessary:

1. Transmit the radar and adjust the following settings:
 

Gain	85 to 90
A/C Sea	zero
A/C Rain	zero
Echo Average	OFF
Noise Rejector	OFF
Interference Rejector	2
2. Open the [Installation] menu and select [Video Init Adjust].
3. Press **ENTER** to show the setting window.
4. Press ▲ or ▼ to adjust the white noise on the display. The setting range is 0 to 31. A larger value increases the gain.
5. Press **ENTER** to finish.

**Note:** If the display is used as a remote display, set [Input Source] to [Slave]. follow the above procedure to adjust the video and take care to ensure the remote display output is similar to the master display output.

**ARPA adjustment**

During the sea trial, adjust the threshold level of the ARPA for short pulse, middle pulse and long pulse.

- Default setting is 2.
- If the ship echoes are difficult to acquire at setting level 2, adjust to level 1.
- If the ARPA symbol moves to a different echo at setting level 2, adjust to level 3.

# 4. OPTIONAL EQUIPMENT

## 4.1 ARP Kit ARP-11

The ARP kit provides automatic radar plotter functions to this radar.

### Necessary parts

Name	ARP kit
Type	ARP-11
Code No.	008-523-050

For the contents of the kit, see the packing list attached to the kit.

1. Unscrew 12 screws and five connector nuts at the rear of the display unit. (See the figure below.)

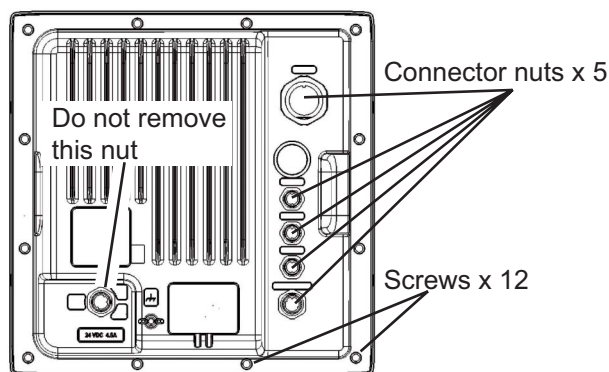

2. Lift the cover slowly and open it as shown below, taking care not to damage the SPU cables.

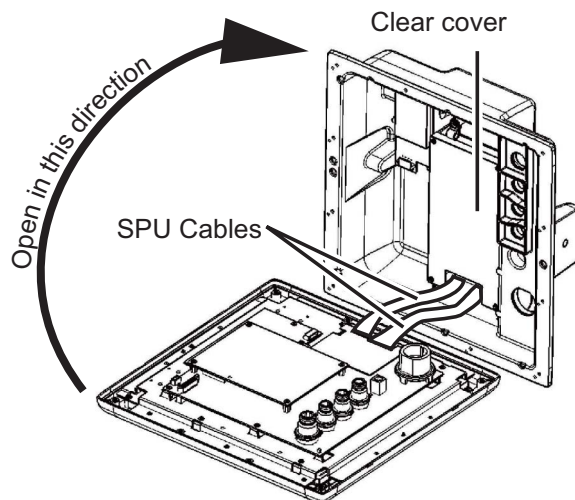

- Mate P107 on the ARP Circuit-board with J214 on the 03P9586 Board and fasten with four screws.

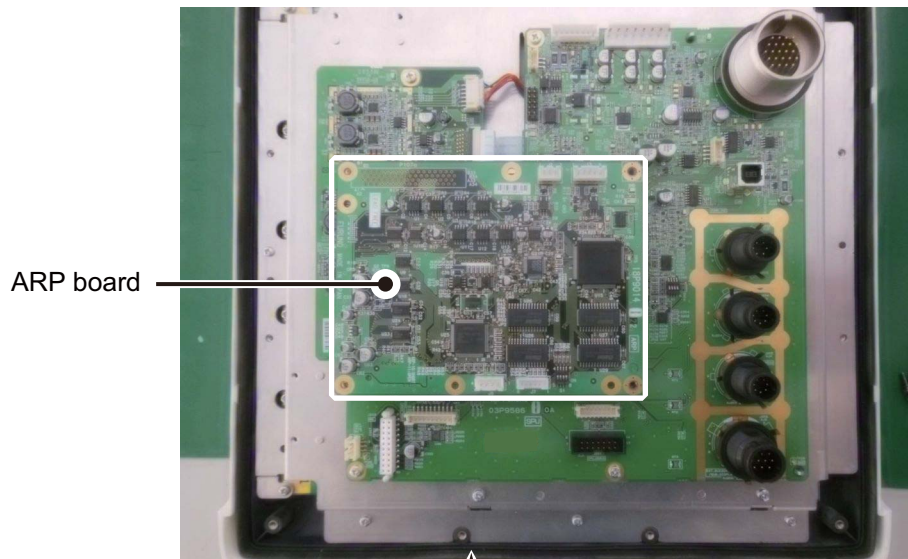

Confirm that the rubber gasket is set securely in the groove around the panel.

- Reassemble the display unit, taking care not to exceed the torque requirements for each connector nut. (See the figure below for nut torque.)

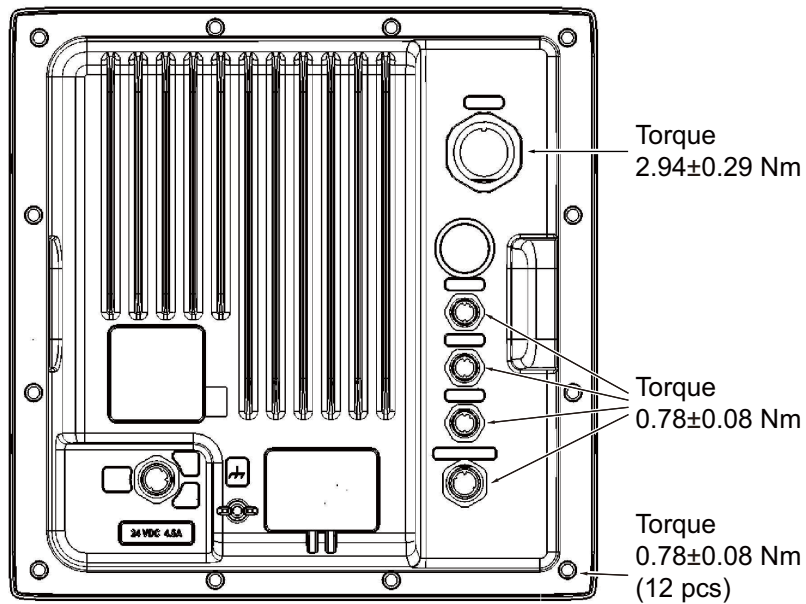

## 4.2 Connection of Buzzer and/or Remote Display

You will need the cables shown below to connect the optional external buzzer and remote display.

- Two-way cable MJ-A10SPFW0001 +R
- MJ-A7SPF0007-050C
- MJ-B24LPF0010-xxx+R (000: 100, 200, or 300)

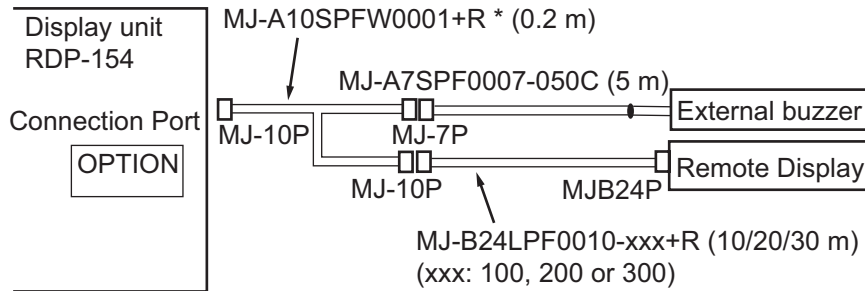

\*: This cable is not required to connect the remote display only.

### External buzzer

When a target enters, or exits, in the target zone, the optional external buzzer gives a loud alarm.

Type                   OP03-21  
Code No.               000-030-097

Name	Type	Code No.	Qty	Comment
Buzzer	PKB42SWH2940	000-153-221-10	1	One NH connector attached
Cable tie	CV-70N	000-162-185-10	4	
Heat-shrink-tube	3x0.25 BLK	000-165-283-10	1	40 mm
Double-sided tape	9760	000-800-851-00	1	25 mm × 25 mm

Attach the two-way cable and MJ-A7SPF0007-050C cable to the OPTION port at the rear of the display unit. See the above figure.

1. Cut the NH connector at the end of the external buzzer cable to an acceptable length.
2. Solder the external buzzer cable to the MJ-A7SPF0007-050C cable as shown below. Before you solder the cores, cut the heat-shrink-tube in half and set the tubes to the cores of the cable. Solder the cores, then set the tubes on the soldered point.

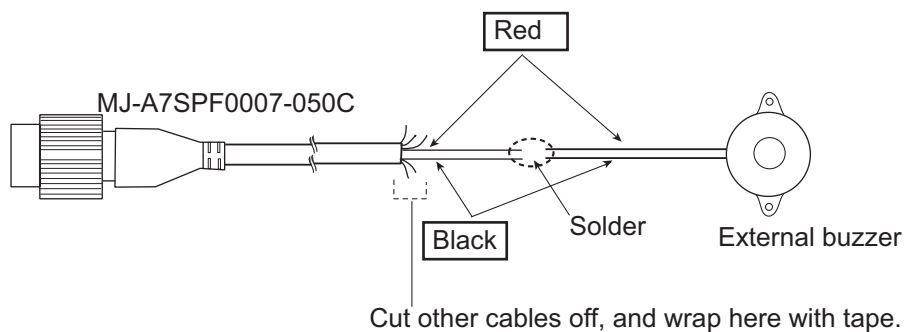





3. Fasten the buzzer with the double-sided tape or two self-tapping screws (3x15 or 3x20, local supply).

# PACKING LIST RDP-154

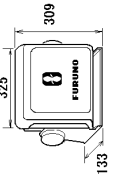
03HM-X-9851-1

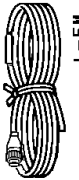
1/1

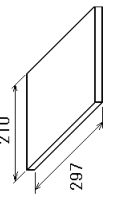
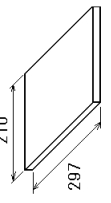
NAME	OUTLINE	DESCRIPTION/CODE No.	Q'TY
<b>ユニット</b>			
指示部		RDP-154-*	1
DISPLAY UNIT		000-024-819-00	**
<b>予備品</b>			
予備品		SP03-17701	1
SPARE PARTS		001-258-000-00	
<b>付属品</b>			
付属品		FP03-12301	1
ACCESSORIES		001-258-020-00	
<b>工事材料</b>			
ケーブル組品MJ		MJ-A3SPF0017-050ZC	1
CABLE ASSY.		000-157-995-10	
工事材料		CP03-35601	1
INSTALLATION MATERIALS		001-258-010-00	
<b>図書</b>			
技術認証要領		J32-00501-*	1
APPLICATION GUIDE		000-179-373-1*	
取扱説明書(和)		OMJ-36320-*	1
OPERATOR'S MANUAL (JP)		000-178-501-1*	(*1)



1.コード番号末尾の[\*\*]は、選択品の代表コードを表します。

1.CODE NUMBER ENDING WITH "\*\*" INDICATES THE CODE NUMBER OF REPRESENTATIVE MATERIAL.

2.(\*1)の書類は、和文仕様専用

2.(\*1) MARKED DOCUMENTS ARE FOR JAPANESE SET ONLY.

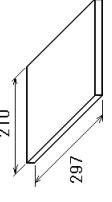
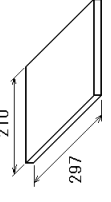
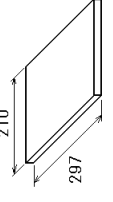
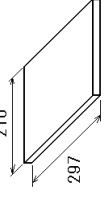
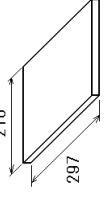
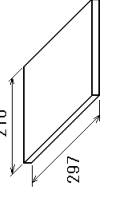
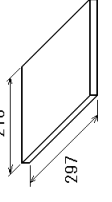
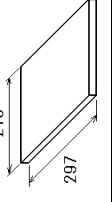
(略図の寸法は、参考値です。DIMENSIONS IN DRAWING FOR REFERENCE ONLY.)

NAME	OUTLINE	DESCRIPTION/CODE No.	Q'TY
取扱説明書(英)		OME-36320-*	1
OPERATOR'S MANUAL (EN)		000-178-502-1*	(*2)
取扱説明書(中)		OZS-36320-*	1
OPERATOR'S MANUAL (CN)		000-178-511-1*	(*3)
操作要領書(和)		OSJ-36320-*	1
OPERATOR'S GUIDE (JP)		000-178-503-1*	(*1)
操作要領書(多言語)		MLG-36320-*	1
OPERATOR'S GUIDE (MLG)		000-178-505-1*	(*2)
操作要領書(中)		NZS-36320-*	1
OPERATOR'S GUIDE (CN)		000-178-504-1*	(*3)
装備要領書(和)		IMJ-36320-*	1
INSTALLATION MANUAL (JP)		000-178-506-1*	(*1)
装備要領書(英)		IME-36320-*	1
INSTALLATION MANUAL (EN)		000-178-507-1*	(*2)
装備要領書(中)		IZS-36320-*	1
INSTALLATION MANUAL (CN)		000-178-512-1*	(*3)
フラッシュマウント型紙		C32-01308-*	1
FLUSH MOUNTING TEMPLATE		000-178-509-1*	

3.(\*2)の書類は、英文仕様専用

3.(\*2) MARKED DOCUMENTS ARE FOR ENGLISH SET ONLY.

4.(\*3)の書類は、中文仕様専用

4.(\*3) MARKED DOCUMENTS ARE FOR CHINESE SET ONLY.

型式/コード番号が2段の場合、下段より上段に代わる過渡期品であり、どちらが入っています。なお、品質は変わりません。

TWO TYPES AND CODES MAY BE LISTED FOR AN ITEM. THE LOWER PRODUCT MAY BE SHIPPED IN PLACE OF THE UPPER PRODUCT. QUALITY IS THE SAME.

C3632-Z01-B



# PACKING LIST

030T-X-9854 -1 1/1

RSB-0070-085A, RSB-0070-086A, RSB-0070-087A, RSB-0073-085A, RSB-0073-086A, RSB-0073-087A

OP03-228

A-3

NAME	OUTLINE	DESCRIPTION/CODE No.	QTY
<b>ユニット</b>			
空中線本体部 SCANNER UNIT		RSB-0070-08*A/-0073-08*A 001-125-220-00 **	1
<b>空中線部工材</b>			
空中線部工材 INSTALLATION MATERIALS		OP03-33801 001-141-670-00	1

コード番号末尾の「\*」は、選択品の代替コードを表します。  
CODE NUMBER ENDING WITH “\*” INDICATES THE CODE NUMBER OF REPRESENTATIVE MATERIAL.

型式コード番号が2段の場合、下段より上段に代わる過渡期品であり、どちらが入っています。なお、品質は変わりません。  
TWO TYPES AND CODES MAY BE LISTED FOR AN ITEM. THE LOWER PRODUCT MAY BE SHIPPED IN PLACE OF THE UPPER PRODUCT. QUALITY IS THE SAME.  
(略図の寸法は、参考値です。DIMENSIONS IN DRAWING FOR REFERENCE ONLY.)



C3539-Z04-B

# PACKING LIST

03HM-X-9852 -0 1/1

OP03-228

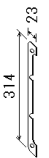
A-3

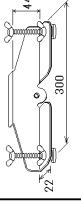
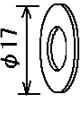
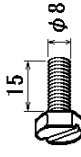
NAME	OUTLINE	DESCRIPTION/CODE No.	QTY
<b>フラッシュマウント部品</b>			
Fマウントフラッシュ FLUSH MOUNT SPONGE H		03-185-1603-1 100-381-961-10	2
Fマウントフラッシュ FLUSH MOUNT SPONGE V		03-185-1602-1 100-381-951-10	2
Fマウント金具組品 FLUSH MOUNT FIXTUREY		OP03-228-1 001-258-040-00	2
ミカキ丸平座金 FLAT WASHER		M8 SUS304 000-167-464-10	2
六角入りワッシャー HEXAGONAL HEAD BOLT		M8X15 SUS304 000-162-916-10	2

型式コード番号が2段の場合、下段より上段に代わる過渡期品であり、どちらが入っています。なお、品質は変わりません。  
TWO TYPES AND CODES MAY BE LISTED FOR AN ITEM. THE LOWER PRODUCT MAY BE SHIPPED IN PLACE OF THE UPPER PRODUCT. QUALITY IS THE SAME.  
(略図の寸法は、参考値です。DIMENSIONS IN DRAWING FOR REFERENCE ONLY.)

C3632-Z02-A



表 1 TABLE 1

寸法区分 (mm) DIMENSION	公差 (mm) TOLERANCE
$L \leq 50$	$\pm 1.5$
$50 < L \leq 100$	$\pm 2.5$
$100 < L \leq 500$	$\pm 3$
$500 < L \leq 1000$	$\pm 4$
$1000 < L \leq 2000$	$\pm 5$

表 2 TABLE 2

種類 TYPE	XN10A	XN12A	XN13A
空中線長 (A) ANT. LENGTH (mm)	1036 $\pm$ 10	1255 $\pm$ 10	1795 $\pm$ 10
回転安全空間 (B) ANT. CLEARANCE (mm)	1200	1400	1940
質量 (kg $\pm$ 10%) MASS	22	25	27

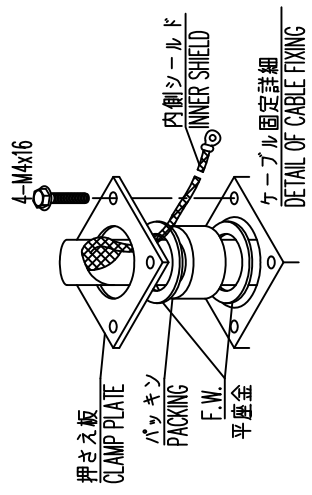
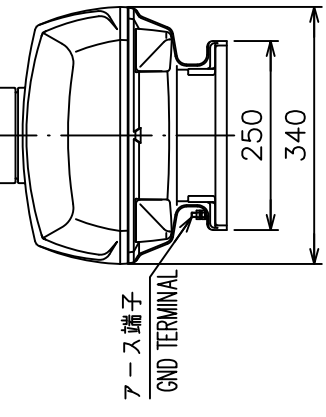
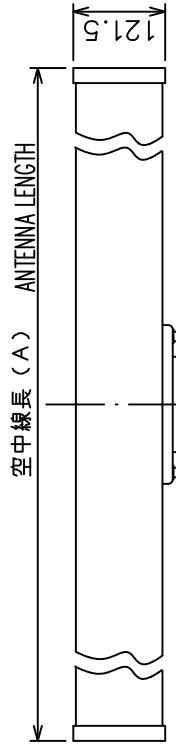
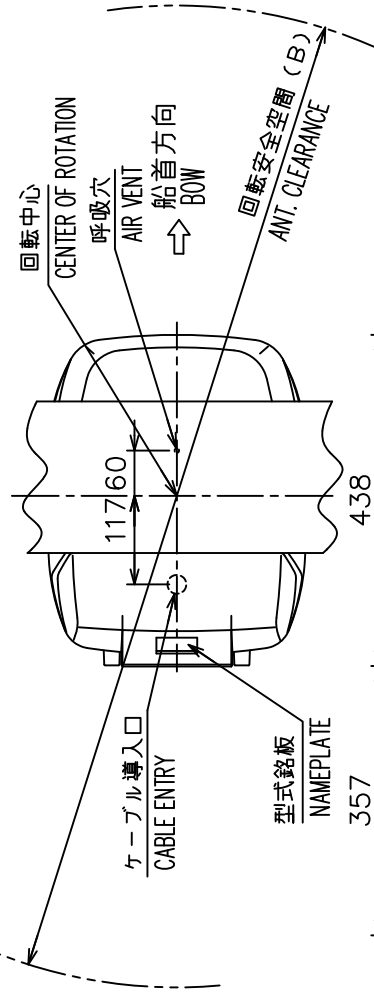

注記 1) 指定な寸法公差は表 1 による。  
2) 取付には M12 ボルトを使用のこと。  
3) 空中線部の取付台に  $\phi 25-30$  のケーブル導入口を開ける。

NOTE 1. TABLE 1 INDICATES TOLERANCE OF DIMENSIONS WHICH IS NOT SPECIFIED.  
2. USE M12 BOLTS FOR FIXING THE UNIT.  
3. MAKE A CABLE ENTRY HOLE  $\phi 25-30$  ON PLATFORM.

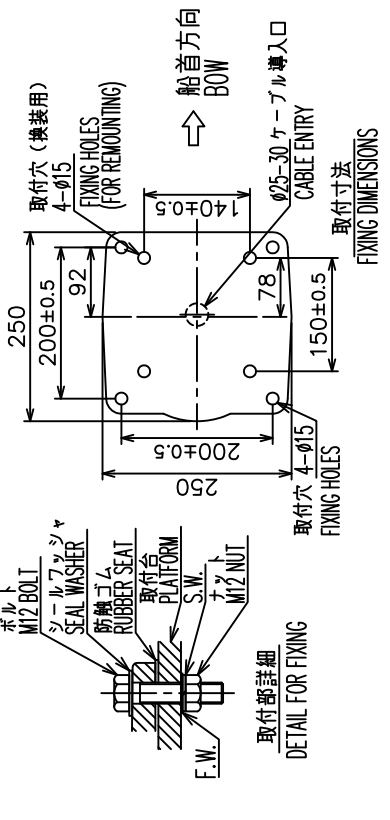
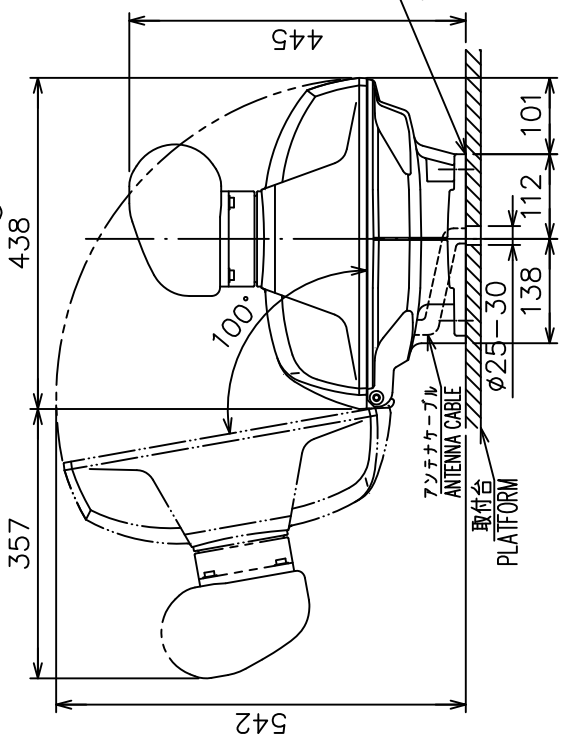

DRAWN	28/Oct/2013	T. YAMASAKI	TITLE	RSB-0070/0072/0073	
CHECKED	30/Oct/2013	H. MAKI	名称	空中線部	
APPROVED	30/Oct/2013	H. MAKI	OTHERS	MODEL 0642 MODEL 1054C Ver.	
SCALE	1/10	質量 表示参照 SEE TABLE 2	外寸図		
DWG.No.	C3539-G03-C	REF.No.	03-142-300G-6	NAME	ANTENNA UNIT
					OUTLINE DRAWING

表 1 TABLE 1

寸法区分 (mm) DIMENSION	公差 (mm) TOLERANCE
L ≤ 50	±1.5
50 < L ≤ 100	±2.5
100 < L ≤ 500	±3

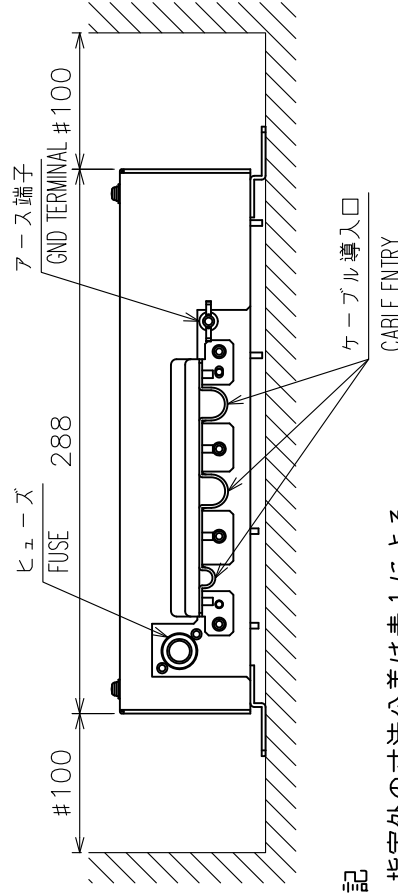
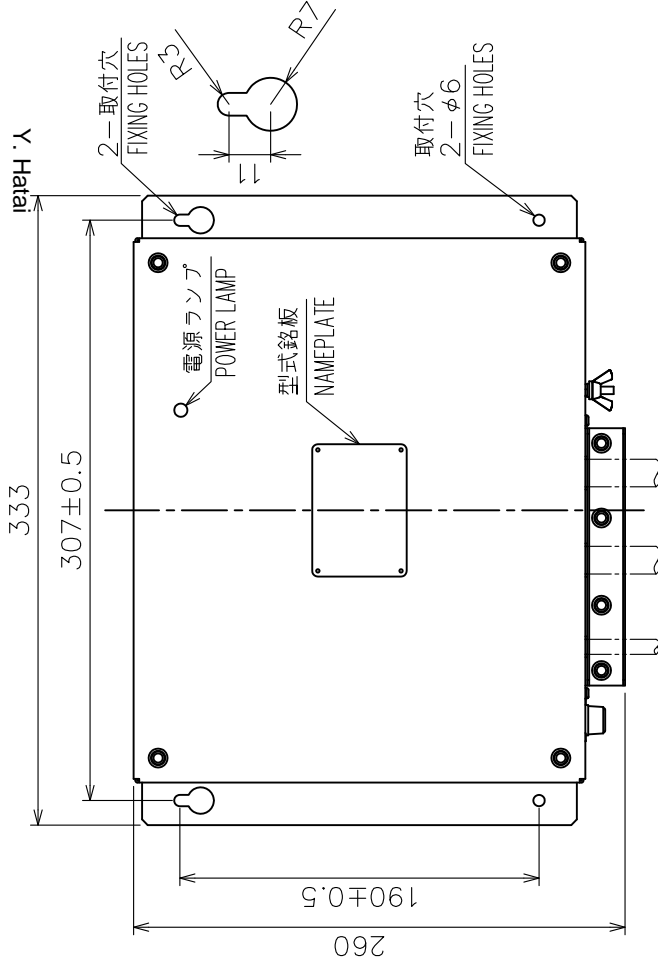
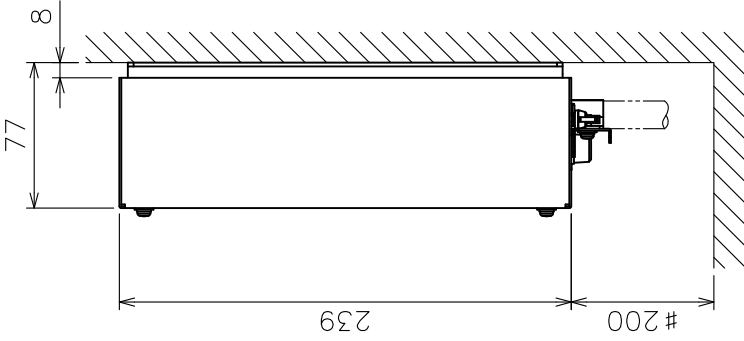

注 記

- 1) 指定外の寸法公差は表 1 による。
- 2) # 印寸法は最小サービス空間寸法とする。
- 3) 取付用ネジはトラスタス呼び径5×20を使用のこと。

NOTE

1. TABLE 1 INDICATES TOLERANCE OF DIMENSIONS WHICH IS NOT SPECIFIED.
2. #: MINIMUM SERVICE CLEARANCE.
3. USE TAPPING SCREWS  $\phi 5 \times 20$  FOR FIXING THE UNIT.

DRAWN	11/Jul/2014	I.YAMASAKI	TITLE	PSU-008
CHECKED	11/Jul/2014	H.MAKI	名称	空中線電源部
APPROVED	11/Jul/2014	H.MAKI	外寸図	
SCALE	1/4	MMS 2.7	NAME	POWER SUPPLY UNIT
DWG.No.	C3548-G01-B	19-025-400G-0	OUTLINE DRAWING	



表1 TABLE 1

寸法区分 (mm) DIMENSION	公差 (mm) TOLERANCE
L ≤ 50	±1.5
50 < L ≤ 100	±2.5
100 < L ≤ 500	±3

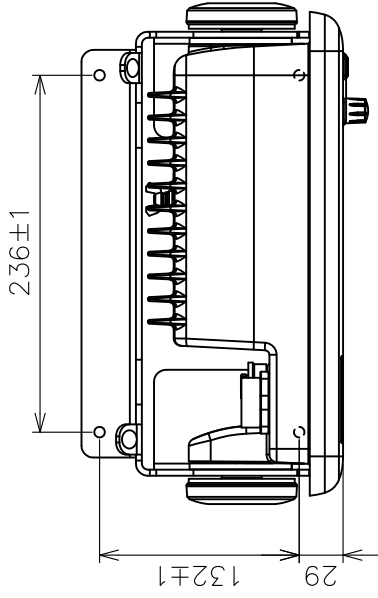
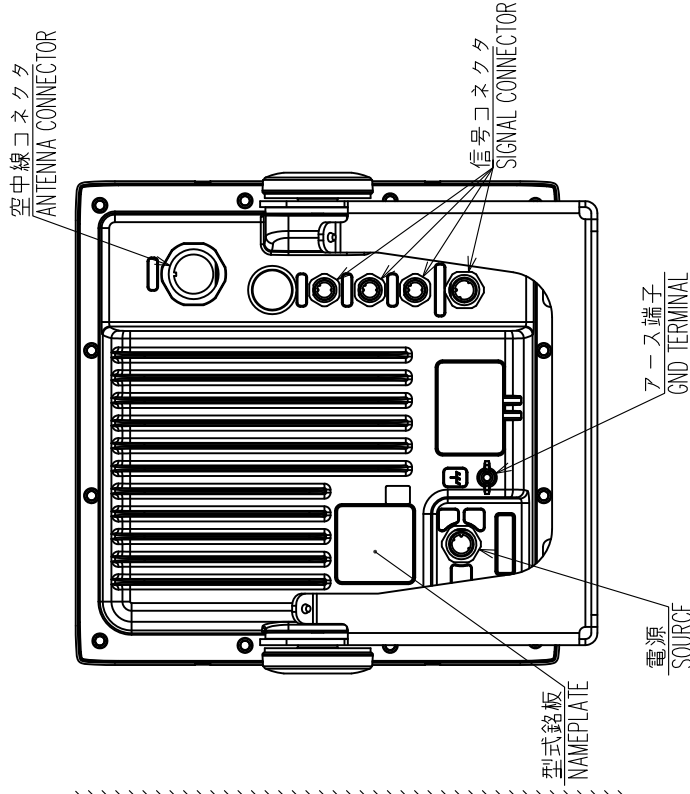
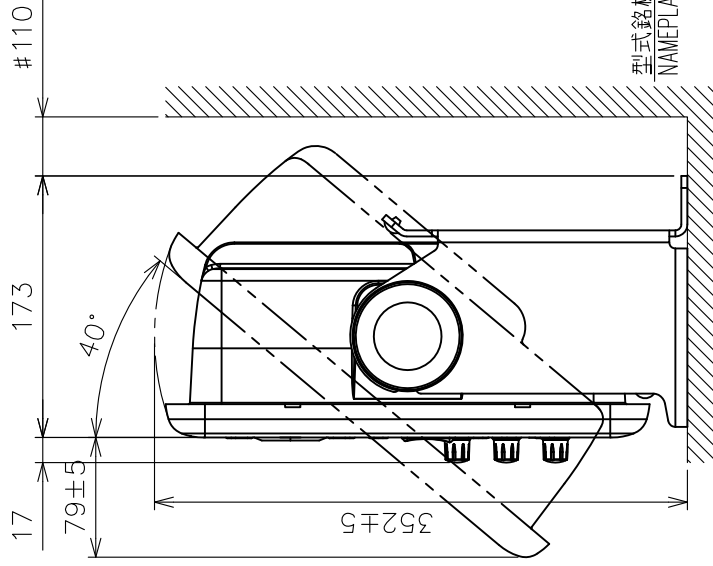
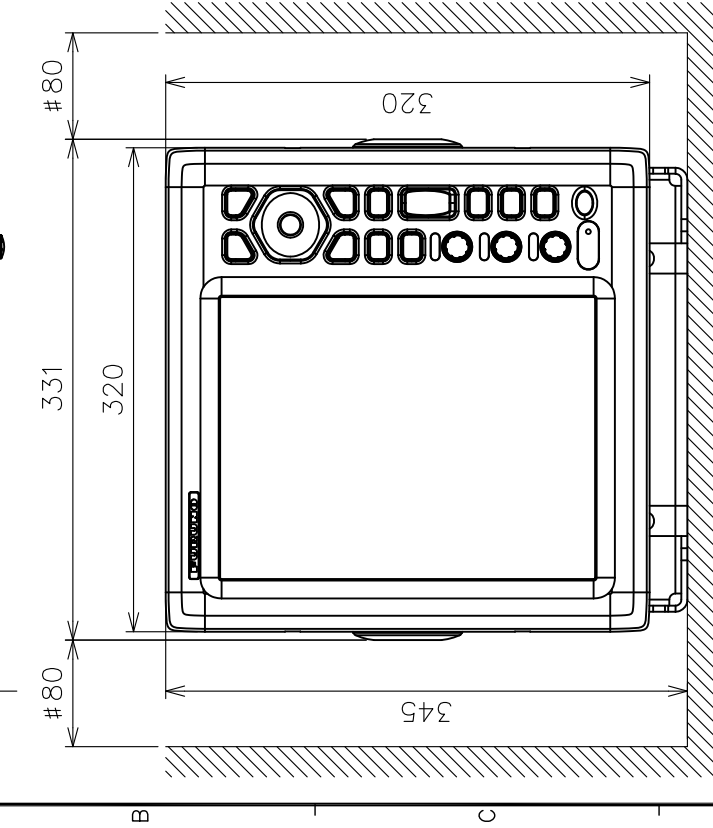

- 注記 1) 指定外の寸法公差は表1による。  
 2) #印寸法は最小サービスマウントとする。  
 3) 取付用ネジは + トラスタッピンネジ呼び径5×20を使用のこと。
- NOTE 1. TABLE 1 INDICATES TOLERANCE OF DIMENSIONS WHICH IS NOT SPECIFIED.  
 2. #: MINIMUM SERVICE CLEARANCE.  
 3. USE TAPPING SCREWS φ5x20 FOR FIXING THE UNIT.

DRAWN	25/Nov/2013	T.YAMASAKI	TITLE	RDP-154
CHECKED	25/Nov/2013	H.MAKI	名称	指示部 (卓上装備)
APPROVED	27/Nov/2013	H.MAKI	外寸図	
SCALE	1/5	WASS 5.8	NAME	DISPLAY UNIT (TABLETOP MOUNT)
DMC No.	C3637-G01-B	REF.No.	03-185-100G-1	OUTLINE DRAWING

表1 TABLE 1

寸法区分 (mm) DIMENSION	公差 (mm) TOLERANCE
L ≤ 50	±1.5
50 < L ≤ 100	±2.5
100 < L ≤ 500	±3

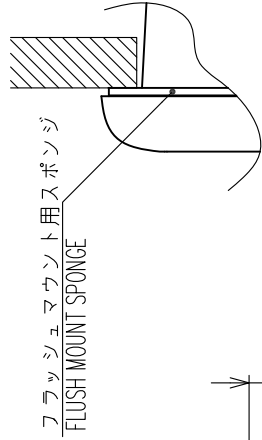

A部 詳細 (尺度: 1/3)  
DETAIL FOR A (SCALE: 1/3)

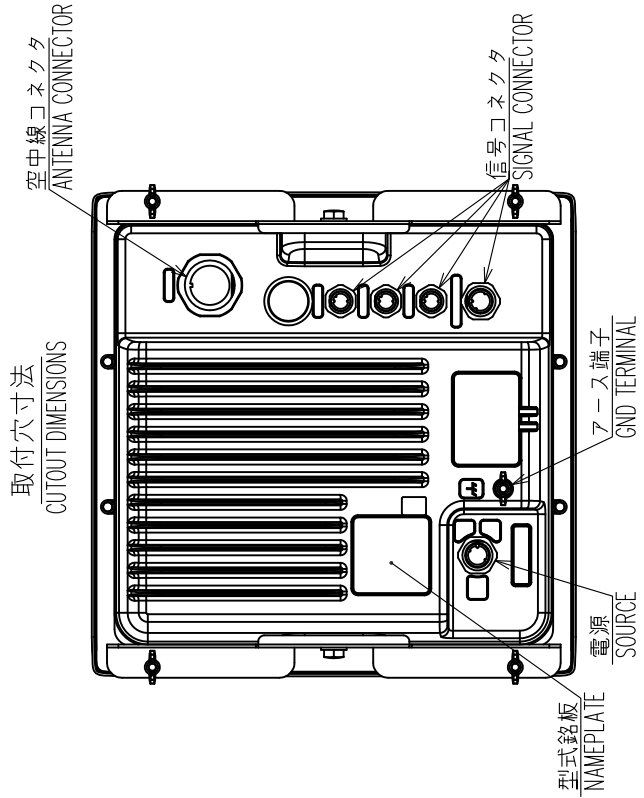
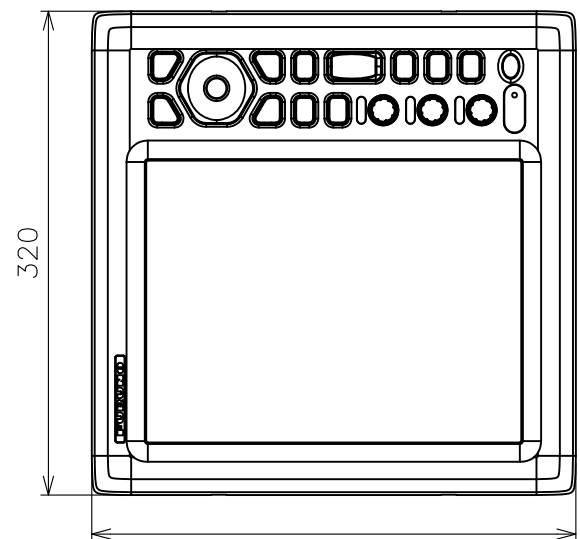
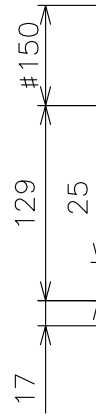
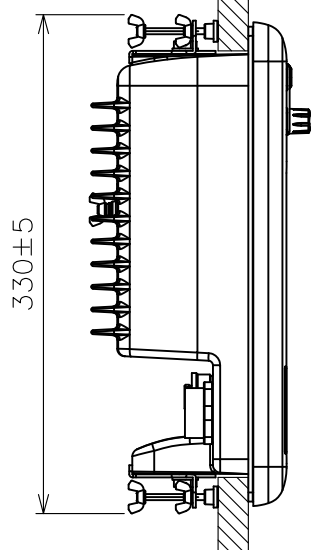

- 注記 1) 指定外の寸法公差は表1による。  
2) #印寸法は最小サービスクリアランスとする。  
3) 壁の厚さ (t) は最小10mm、最大20mmとする。
- NOTE 1. TABLE 1 INDICATES TOLERANCE OF DIMENSIONS WHICH IS NOT SPECIFIED.  
2. # MINIMUM SERVICE CLEARANCE.  
3. BULKHEAD THICKNESS (t): 10 ≤ t ≤ 20.

DRAWN	25/Nov/2013	T.YAMASAKI	TITLE	RDP-154
CHECKED	25/Nov/2013	H.MAKI	名称	指示部 (埋込装備)
APPROVED	27/Nov/2013	H.MAKI	NAME	外寸図
SCALE	1/5	WASS 5.3 t	REF.No.	03-185-110G-1
DMC.No.	C3632-G02-B			

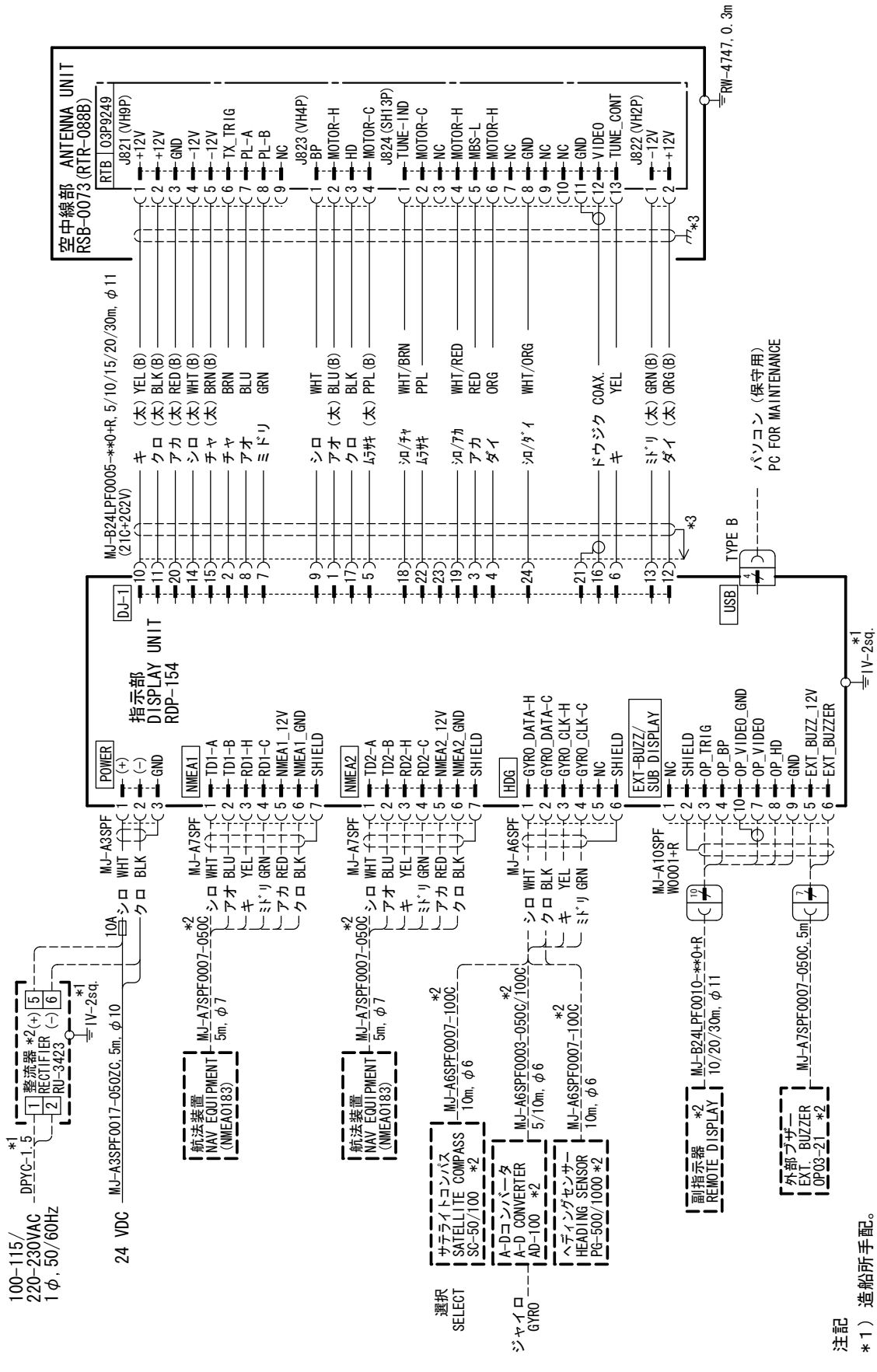

DRAWN	24/Feb./2014	T. YAMASAKI	TITLE	FR-8045
CHECKED	24/Feb./2014	H. MAKI	名称	船舶用レーダー
APPROVED	25/Feb./2014	H. MAKI	相互結線図	
SCALE	1/25	MASS	NAME	MARINE RADAR
DWG. No.	C3635-001-C	kg	REF. No.	03-185-6002-0
				INTERCONNECTION DIAGRAM

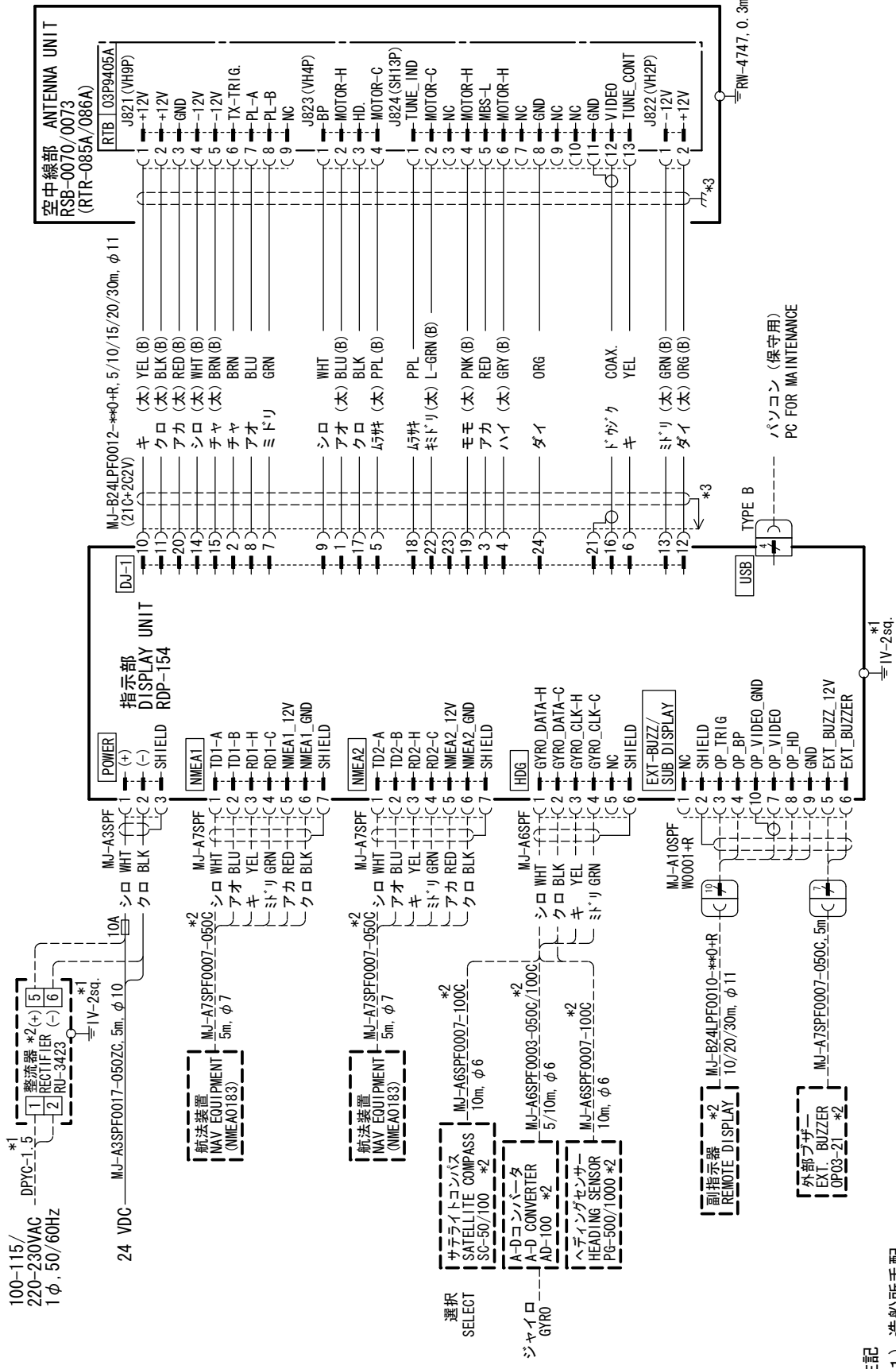

注記  
 \*1) 造船所手配。  
 \*2) オプション。  
 \*3) シールドは両端で完全にアースする。

NOTE  
 \*1: SHIPYARD SUPPLY.  
 \*2: OPTION.  
 \*3: GROUND SHIELD EFFECTIVELY AT BOTH ENDS.

DRAWN	24/Feb/2014	T. YAMASAKI	TITLE	FR-8065/8125
CHECKED	24/Feb/2014	H. MAKI	名称	船舶用レーダー
APPROVED	25/Feb/2014	H. MAKI		相互結線図
SCALE	1/25	kg	NAME	MARINE RADAR
DWG. No.	C3632-001-C	REF. No.	03-185-6003-0	INTERCONNECTION DIAGRAM



**ECF**

(Elemental Chlorine Free)

The paper used in this manual  
is elemental chlorine free.

**FURUNO ELECTRIC CO., LTD.**

9-52 Ashihara-cho,  
Nishinomiya, 662-8580, JAPAN

• FURUNO Authorized Distributor/Dealer

All rights reserved. Printed in Japan

Pub. No. IME-36320-B

(AKMU) FR-8045/8065/8125

A : JAN. 2014

B : AUG. 25, 2014



0 0 0 1 7 8 5 0 7 1 1