



GENUINE PARTS

INSTALLATION INSTRUCTIONS

1. DESCRIPTION: Auto-Dimming Inside Mirror with Compass and Homelink®

2. APPLICATION: Rogue (2008)

3. PART NUMBER: 999L1 VW002

4. KIT CONTENTS:

Item	Qty	Description	Service Part Number
A	1	Auto-Dimming Mirror with Compass and Homelink®	999L1 VW000S1
B	1	Parts Kit	999L1 VW003
C	1	Harness	
D	1	Wire Cover	
E	5	Wire Tie	
F	6	Foam Tape	
G	1	Posi-Tap™	
H	2	A-Pillar Clip	76988 3DN0A
I	1	Homelink® User Guide	
J	1	Manual, Installation Instruction Download	999V2 AW000

5. PRE-INSTALLATION CAUTION / NOTES:

WARNING

- Disconnect vehicle battery before installing Auto-Dimming Inside Mirror Kit to prevent possible shock injury during installation.

CAUTION

- Dealer installation recommended. This installation instruction will reference the service manual.
- Cut the excess wire tie(s) as flush with the head as possible. Face head of cable tie away from sheet metal and other objects.
- Use caution when removing / re-installing interior components to avoid damage, scratches, or breaking of mounting clips.

6. TOOLS REQUIRED:

- | | | |
|--------------------------|-------------------------|--------------------------|
| 1. Clean Rag | 4. 3mm Flat Screwdriver | 6. Phillip's Screwdriver |
| 2. Needle Nose Pliers | 5. Panel Removal Tool | 7. Side Cutters |
| 3. T-20 Torx Head Driver | | |

HOMELINK® AND THE HOMELINK HOUSE® ARE REGISTERED TRADEMARKS OF JOHNSON CONTROLS, INC.

Auto-Dimming Inside Mirror with Compass and Homelink®

7. VEHICLE PREPARATION:

- 1) Apply parking brake.
- 2) Record the customer radio presets.

Presets	1	2	3	4	5	6	
A							
B							
C							

- 3) Make sure that the shift lever is engaged in the "P" position.
- 4) Turn the ignition switch OFF.
- 5) Open engine hood.
- 6) Disconnect negative battery terminal.

8. INSTALLATION PROCEDURE:

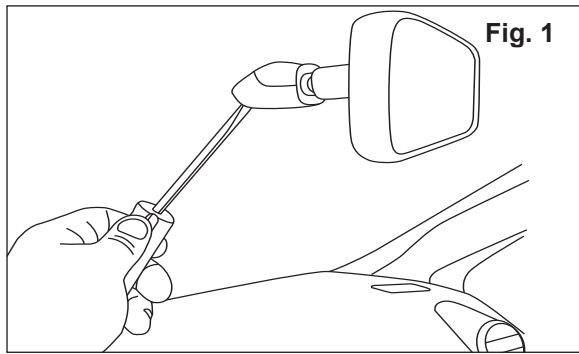

- 1) Removal of OE rearview mirror
 - a) Tape the end of a 3mm screwdriver with electrical tape (or equivalent) to prevent damage to windshield.
 - b) Insert the flat end of a 3mm screwdriver into the opening at the bottom of the mirror mount. **(Fig. 1)**
 - c) Push screwdriver up into the mount to disengage locking tab. **(Fig. 1)**
 - d) While still applying upward pressure with the screwdriver, grasp the mirror bracket and lift the mirror up towards the headliner and off the mirror mounting bracket. **(Fig. 1)**

Auto-Dimming Inside Mirror with Compass and Homelink®

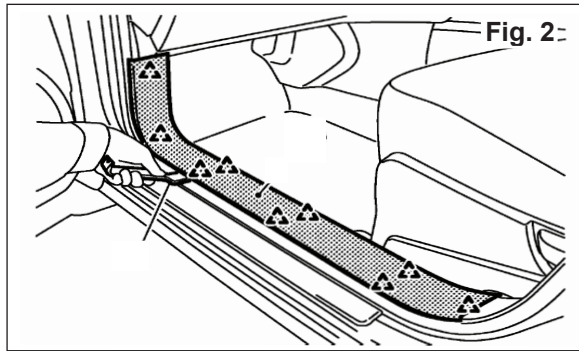

- 2) Remove driver side front kicking plate
 - a) Using panel removal tool, pry up at each clip location (4). **(Fig. 2)**
 - b) Lift the part up to remove.

- 3) Remove the following interior parts as shown in Fig. 3 (Refer to vehicle service manual)
 - a) LH Dash Side Lower Finisher
 - b) LH Instrument Side Mask
 - c) Door Mirror Remote Control Switch
 - d) LH Front Body Side Welt (Partially remove to assist in the removal of LH Front Pillar Finisher)

CAUTION

- During removal of clips, ensure proper extraction force is applied.

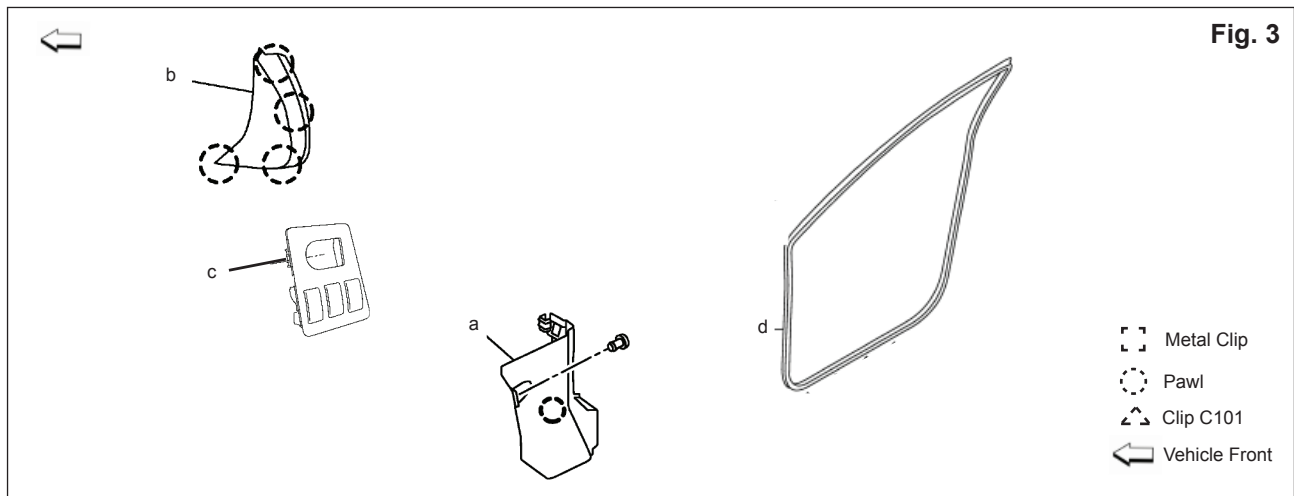

Auto-Dimming Inside Mirror with Compass and Homelink®

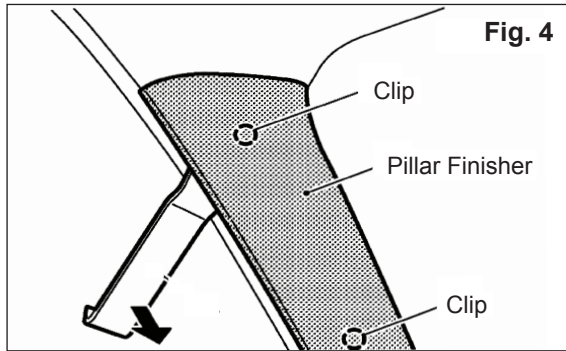

- 4) Remove LH front pillar finisher.
 - a) Disengage front pillar finisher fixing clips using panel removal tool. **(Fig. 4)**
 - b) Pull the front pillar finisher partially toward the vehicle.
 - c) Insert panel removal tool (A) between the front pillar finisher bottom side and body side to disengage the clip. **(Fig. 5)**
 - d) Once free, pull the front pillar finisher upwards and use a cutter knife to cut both clips.
 - e) Remove front pillar finisher.

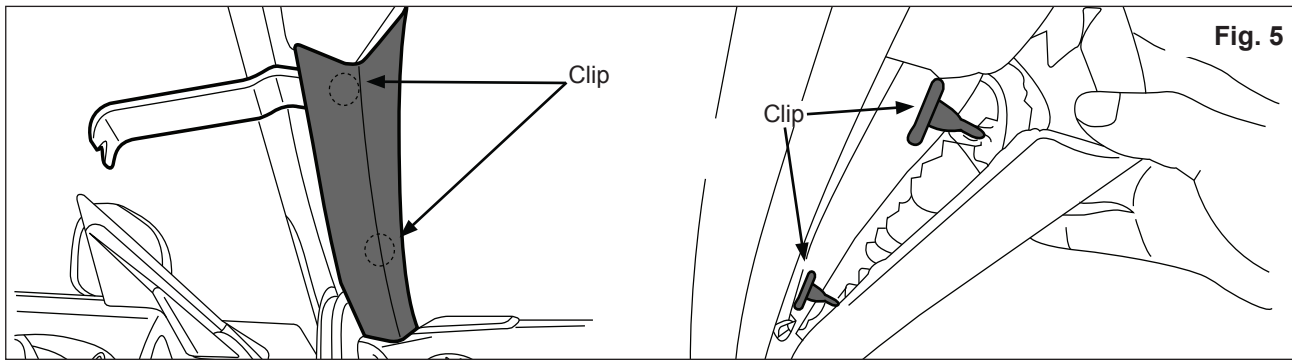

⚠ CAUTION

- Exercise caution when removing and installing LH front pillar finisher due to side airbag placement. Reference Figure 4 and 5 above for further detail.
- Do **NOT** re-use LH front pillar finisher clips. Both LH front pillar finisher clips (P/N 76988 3DN0A) **MUST** be replaced during re-installation of finisher.

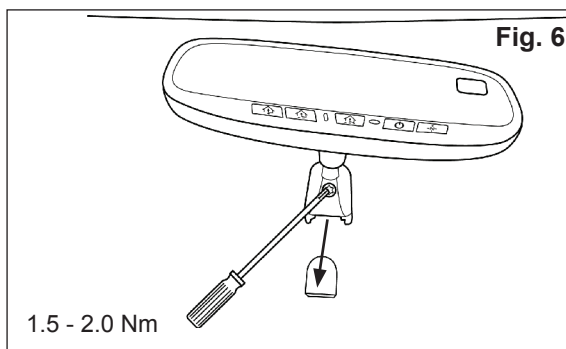

- 5) Install rearview mirror
 - a) Plug the harness connector into the back of the EC mirror.
 - b) Slide the mirror base over the button on the windshield. **(Fig. 6)**
 - c) Using a T-20 Torx head driver, tighten the screw on the mirror mount 1.5 - 2.0 Nm (1.3 ft - lbs) **(Fig. 6)**

Auto-Dimming Inside Mirror with Compass and Homelink®

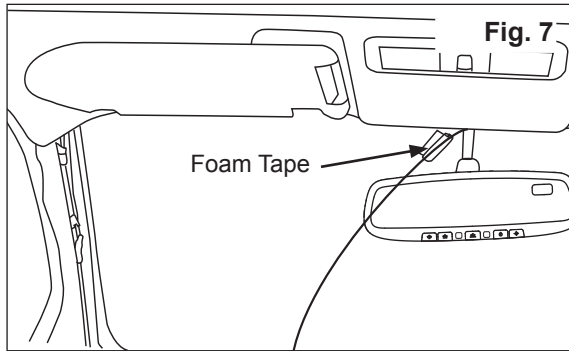

- d) Wrap 1 piece of foam tape around harness and using panel removal tool, tuck between headliner and roof above EC mirror. **(Fig. 7)**

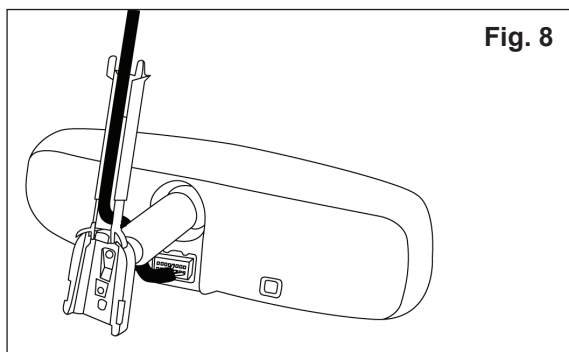

- e) Route the harness into the groove of the wire cover and attach to the mirror mount. **(Fig. 8)**
- f) Slide the forks on top of the wire cover, into the headliner. **(Fig. 8)**

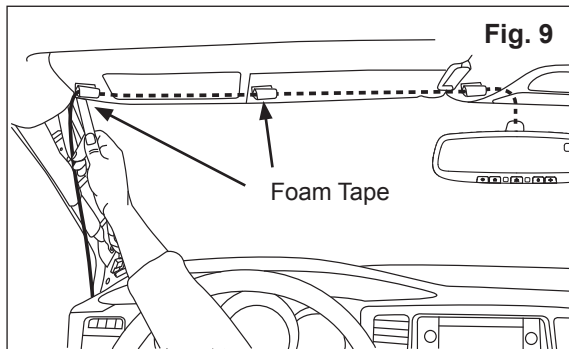

- g) Wrap a piece of foam tape around harness at center of sun visor and where the headliner bends towards driver-side door. **(Fig. 9)**
- h) Using panel removal tool, tuck the wire harness between the headliner and roof. **(Fig. 9)**

Auto-Dimming Inside Mirror with Compass and Homelink®

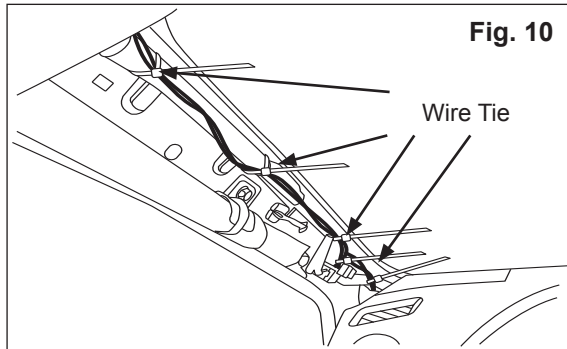

- i) Route harness down driver-side A-pillar and secure to existing vehicle harness with 4 wire ties. (Fig. 10)

⚠ CAUTION

- Do not tie wrap harness to clear drain tube.

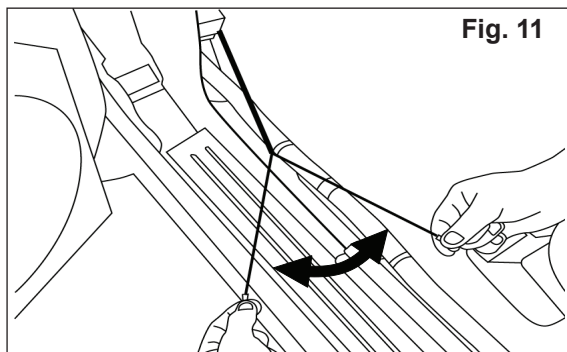

- j) Pull power and ground wires apart approximately 24 inches. (Fig. 11)

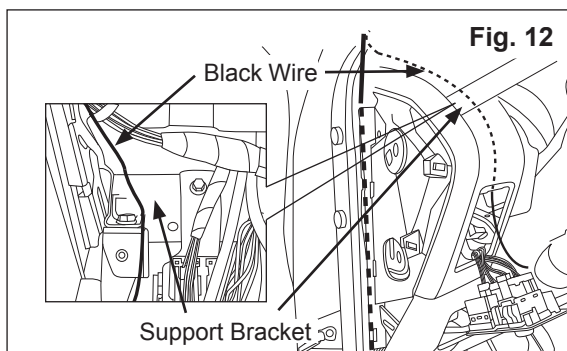

- k) Carefully route Black ignition wire **without** ring terminal through center dash panel, over the support bracket and out of the access port near the power mirror switch. (Fig. 12)

Auto-Dimming Inside Mirror with Compass and Homelink®

- 6) Secure gray end of the wire tap to **Sky Blue Wire**.
(Fig. 13)
 a) See steps 7 - 11 for wire tap installation instructions.

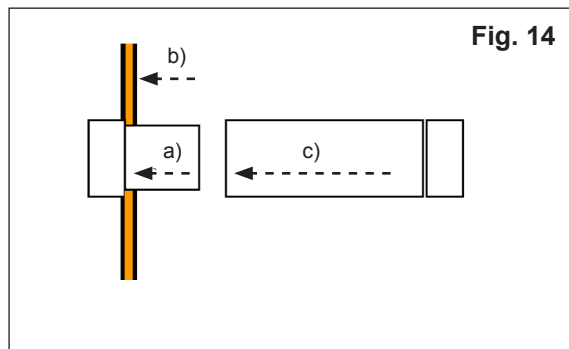
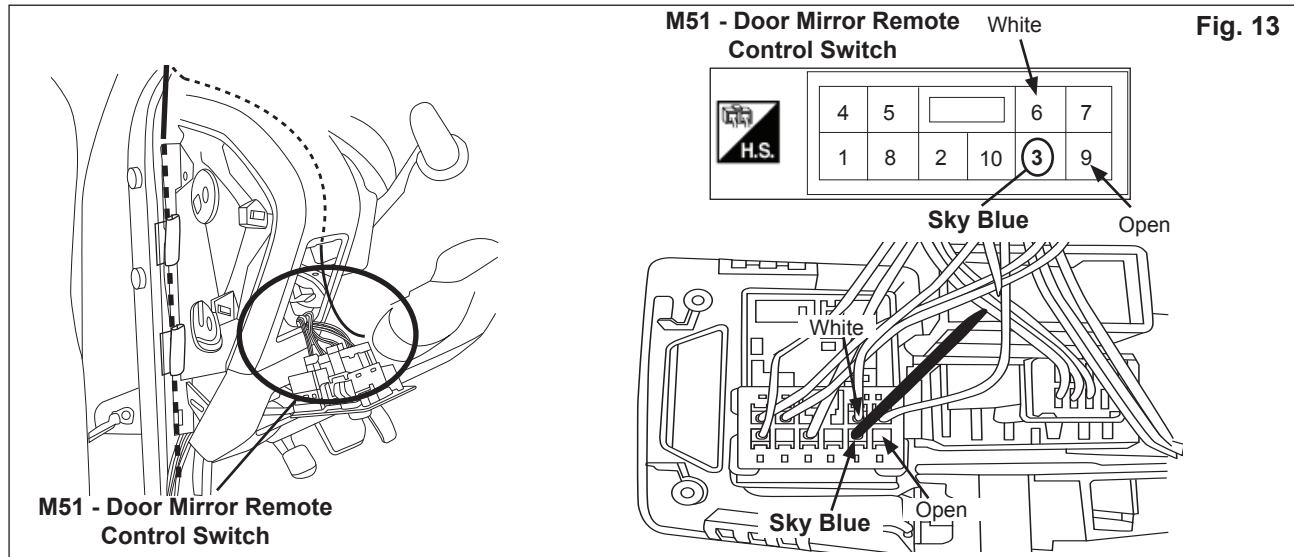

- 7) Tap Vehicle Wire. **(Fig. 14)**
 a) Remove cap (slot side) from tap body.
 b) Slide the cap around vehicle wire.
 c) Tighten the tap **TIGHT** with finger pressure.

NOTE:
 Do not re-use the tap for subsequent re-installation.

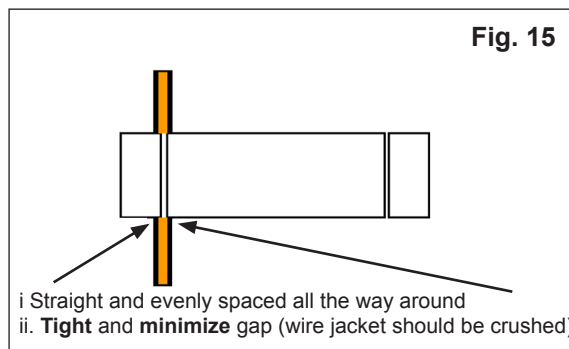

- 8) Inspect the Tap to Ensure Correct Installation.
(Fig. 15)

NOTE:
 Avoid putting pressure on the vehicle wire and tap for the rest of the installation.

Auto-Dimming Inside Mirror with Compass and Homelink®

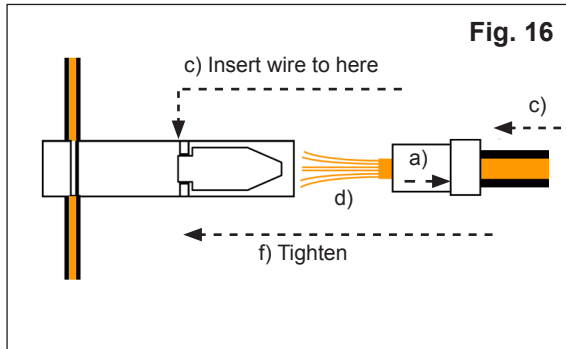

9) Tap Accessory Wire. (Fig. 16)

- Remove tap (non-pierce) side from tap.
- Remove the protective stub.
- Insert wire through the non-pierce side opening.
- Spread the individual strands into fan shape.
- Insert wire into the tap body and ensure that it is all the way in.
- Tighten the tap **TIGHT** with finger pressure.

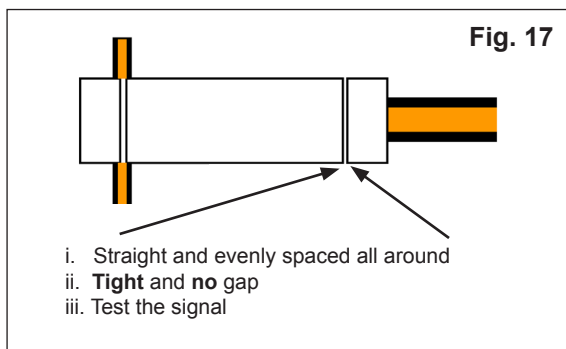

10) Confirm the Tapped Accessory Wire (Fig. 17)

- Inspect the tap to ensure correct installation.
- Test the signal to ensure that it is working properly.

NOTE:

Avoid putting pressure on the vehicle wire, tap, and accessory wire for the rest of the installation.

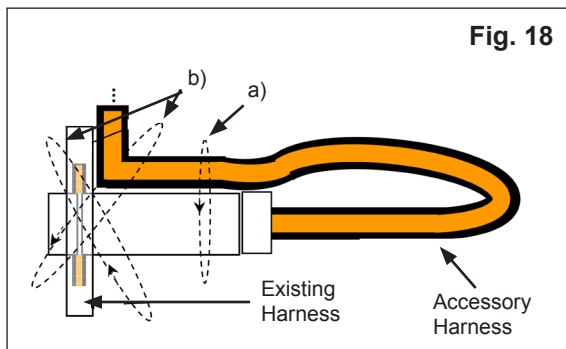

11) Secure the Tap (Fig. 18)

- Secure the tapped wire on the non-pierce side to the body of the posi-tap with electrical tape (2 revolutions).
- Secure the body to harness where vehicle wire is being tapped with electrical tape (2 revolutions).

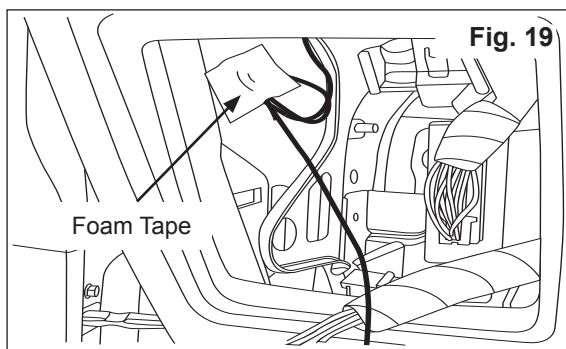

- Bundle excess Black wire **without** ring terminal and secure to plastic dash inner with 1 piece of foam tape. (Fig. 19)

Auto-Dimming Inside Mirror with Compass and Homelink®

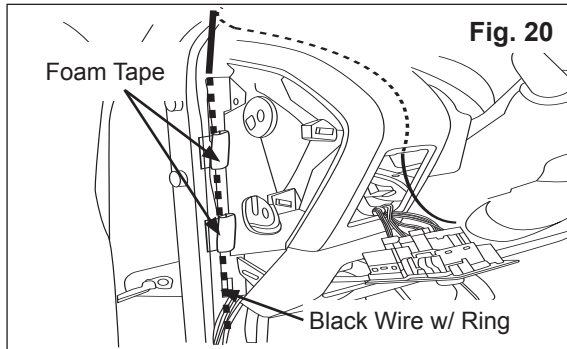

- d) Wrap 2 pieces of foam tape around Black wire **with** ring terminal and tuck between vehicle body and center dash. **(Fig. 20)**

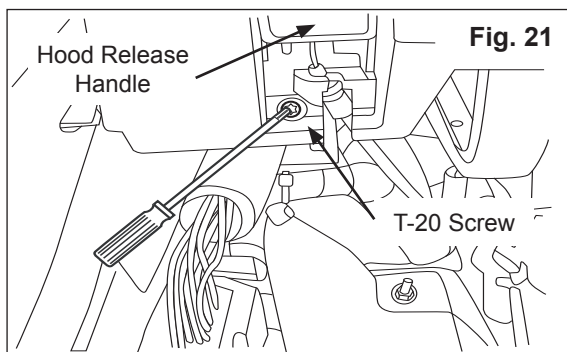

- e) Locate and remove the T-20 screw just below hood release handle near footwell area. **(Fig. 21)**

- f) Route Black wire **with** ring terminal to footwell area.

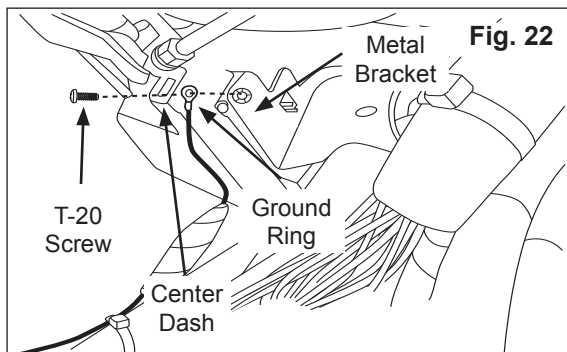

- g) Reinstall T-20 screw, ensuring Black ground wire ring terminal is installed between center dash and metal bracket to ensure continuity. **(Fig. 22)**

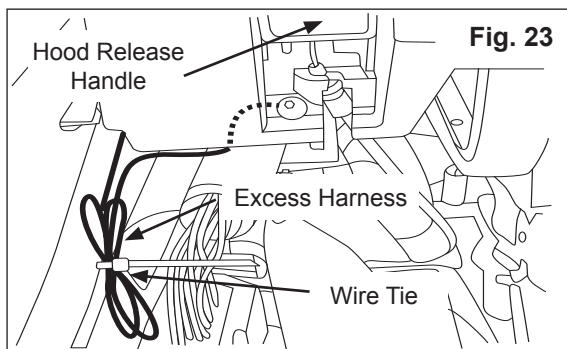

- h) Bundle excess Black wire **with** ring terminal in footwell area to existing vehicle harness with 1 wire tie. **(Fig. 23)**

Auto-Dimming Inside Mirror with Compass and Homelink®

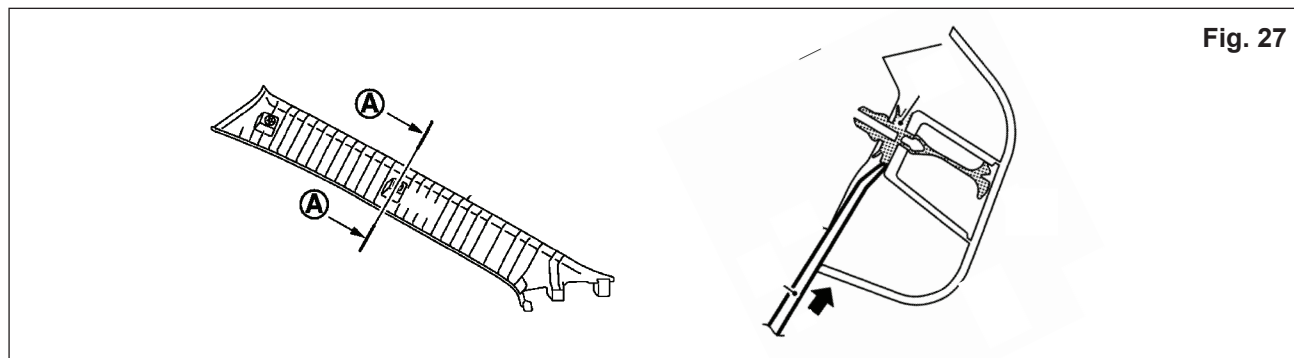
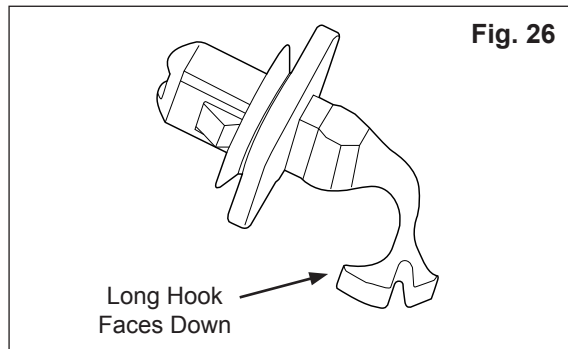
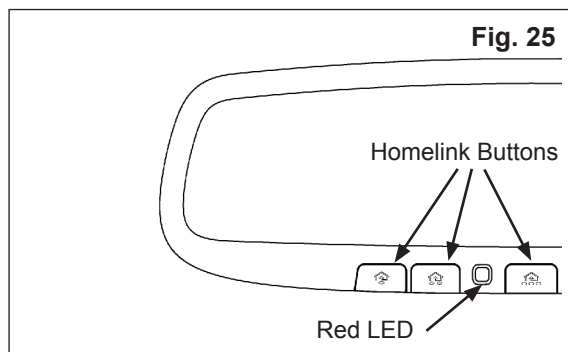
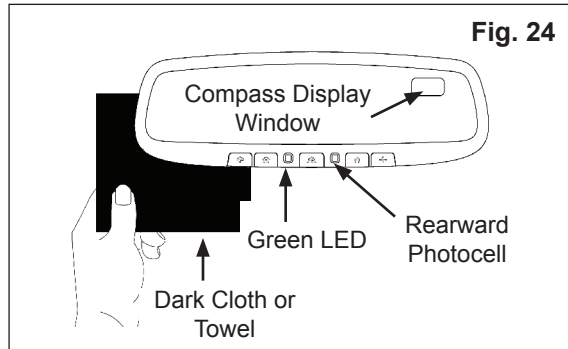

12) Testing

- Reconnect the vehicle's negative battery cable.
- Tighten negative battery terminal nut to 4.1 Nm.
- Turn the ignition switch to ON.
- Ensure vehicle is in a failure well lit area.
- Check to see that the green LED is illuminated. If it is not, press the "⏻" button to turn it on.
- Cover the forward-looking photocell (located below the wire harness connection on the back of the mirror) with a dark cloth or towel. After a few seconds, the mirror should begin to darken. Timing will vary with ambient light levels and a flashlight may be shined on the rearward photocell if needed, to accelerate effect.
- Remove the cover from the forward-looking photocell and the mirror will begin to clear.
- Push the "⏻" button to ensure compass display shows either a direction such as "NE" or a "C", and that it can be turned ON and OFF.
- Push each Homelink® button one at a time and verify that the LED indicator to the left of the center switch illuminates with a red LED.
- Testing is now complete.

13) Trim excess material off all wire ties.

14) Re-install the LH front pillar finisher

- Insert new clip (P/N 76988 3DN0A) into the finisher hole ensuring the long hook faces down. **(Fig. 26)**
- Insert the base of the finisher.
- Insert panel removal tool (A) between the front pillar finisher bottom side and body side and press clips into body. **(Fig. 27)**
- Push the finisher toward the vehicle body to attach.

Auto-Dimming Inside Mirror with Compass and Homelink®

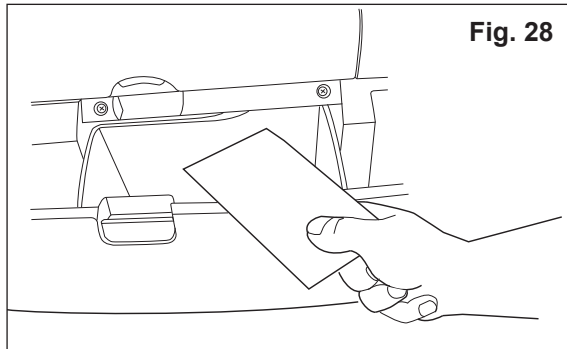

15) Final Assembly

- Reinstall in reverse order, all trim pieces removed during installation.
- Remove fingerprints, smudges, dirt, etc from mirror glass.
- Place the operation instruction card in the vehicle glovebox. **(Fig. 28)**
- Verify each reinstalled component for proper fit and function.
- Verify operation of all buttons disconnected during installation.

⚠ CAUTION

- Use caution when re-installing interior components to avoid damage, scratches, or breaking of mounting clips. Refer to the vehicle specific service manual for more information.

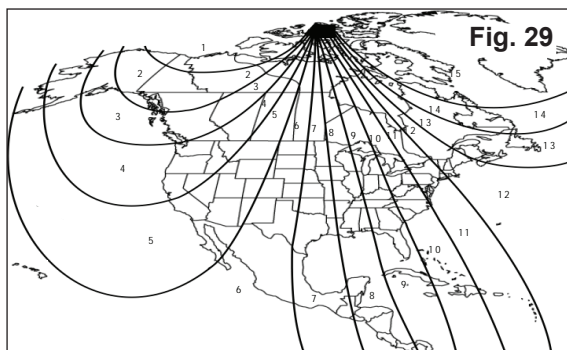

16) Set Compass Zone

- With the display turned "ON", push the "⏏" button for 3 seconds, until a number appears in display (numbers correspond to regional compass zones).
- Press and release "⏏" button to scroll through zone numbers.
- Release "⏏" button when correct zone number is displayed. Zone number will disappear and display will return to showing either a directional heading or a "C" after 5 seconds of no switch activity.

17) Calibrate Compass

- Drive vehicle in circles (360°) at 5 mph or less until compass display window shows a direction.

9. Post Installation Check Sheet

- Inspect the vehicle interior and exterior for damage.
- Confirm proper operation of vehicle systems.
- Reset radio presets to the recorded settings.
- If equipped, verify proper sunroof operation and perform the reset procedure if necessary. Refer to Service Manual requirements.
- Check the trim for proper flush fit after re-installing the interior components.

Posi-Tap™ is protected by patent # 5,228,875 5,695,369 5,868,589 6,692,313 Jap 2881414 Aus 708700 Tia 103534 Can 2204826 Mex 200626 Korea 477279 China Z197105562.9 & others pending.