

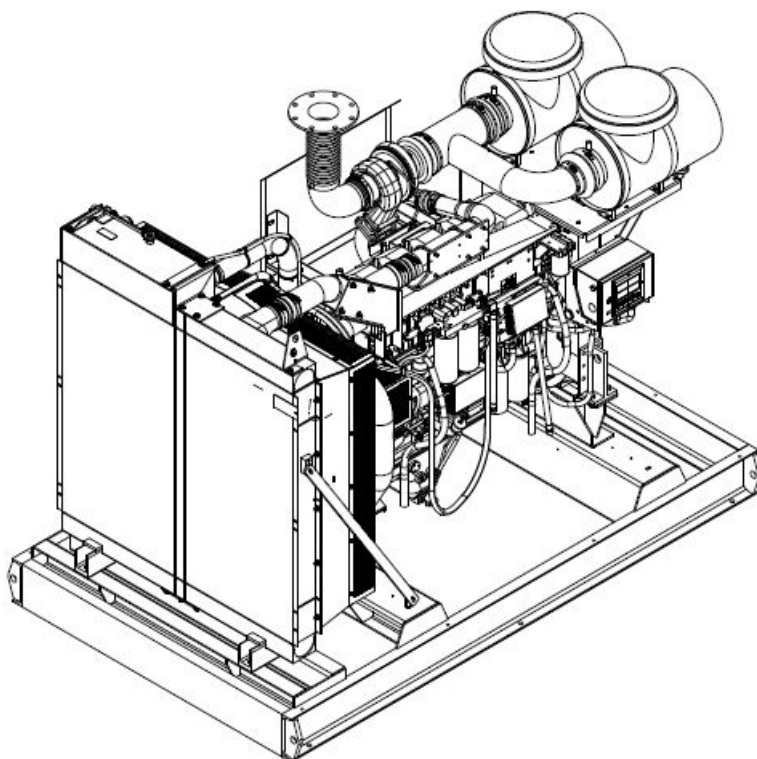

Fire Pump Drive Engines CFP23E Radiator-cooled Series

Operation and Maintenance Manual





This manual contains proprietary information to equipment produced by Cummins Sales and Service and Cummins Inc. and is being supplied solely for the purpose of operating, maintaining, and servicing the fire pump drive engine purchased from Cummins Sales and Service in De Pere, Wisconsin.

Please visit us at cumminsfirepower.com to view the English version of this manual in color, as well as experience a wealth of information about Cummins fire pump drive engines.



This product has been manufactured under the controls established by a Bureau Veritas Certification approved management system that conforms with ISO 9001:2015.



Fire Pump Drive Engine

Limited Warranty

Description

This limited warranty applies to all Cummins fire pump drive engines (hereinafter referred to as "Cummins" branded fire pump drive engines and associated accessories (hereinafter referred to as "Product")). This warranty covers any failures of the Product, under normal use and service, which result from a defect in material or factory workmanship.

Warranty Period:

The warranty start date for stationary Product is the date of initial start-up, demonstration or eighteen (18) months after factory ship date, whichever is sooner.

Base Engine Warranty Duration (whichever occurs first): 2 years/2000 hours.

Cummins Responsibilities:

In the event of a failure of the Product during the warranty period due to defects in material or workmanship, Cummins will only be responsible for the following costs:

- All parts and labor required to repair the Product.
- Reasonable travel expenses to and from the Product site location.
- Maintenance items that are contaminated or damaged by a warrantable failure.

Owner Responsibilities:

The owner will be responsible for the following:

- Notifying a Cummins distributor or dealer within thirty (30) days of the discovery of failure.
- Installing, operating, commissioning and maintaining the Product in accordance with Cummins published policies and guidelines.
- Providing evidence for date of commissioning.
- Providing sufficient access to and reasonable ability to remove the Product from the installation in the event of a warrantable failure.
- In addition, the owner will be responsible for:
 - Incremental costs and expenses associated with Product removal and reinstallation resulting from difficult or non-standard installations.
 - Costs associated with Fire Watch Protection during Product being repaired.
 - Costs associated with labor overtime and premium shipping requested by the owner.
 - All downtime expenses, fines, all applicable taxes, and other losses resulting from a warrantable failure.



Limitations:

This limited warranty does not cover Product failures resulting from:

- Inappropriate use relative to designated power rating or application guidelines.
- Normal wear and tear, negligence, accidents or misuse.
- Improper and/or unauthorized installation.
- Lack of maintenance or unauthorized repair.
- Noncompliance with any Cummins published guideline or policy.
- Use of improper or contaminated fuels, coolants or lubricants.
- Improper storage before and after commissioning.
- Owner's delay in making Product available after notification of potential Product problem.
- Replacement parts and accessories not authorized by Cummins.
- Owner or operator abuse or neglect such as: operation without adequate coolant or lubricants; over-fueling; over-speeding; lack of maintenance to lubricating, cooling or air intake systems; late servicing and maintenance; improper storage, starting, warm-up, run-in or shutdown practices, or for progressive damage resulting from a defective warning device.
- Damage to parts, fixtures, housings, attachments and accessory items that are not part of the fire pump package.

This limited warranty does not apply to:

- Costs of maintenance, adjustments, installation, commissioning or start-up.
- Starting batteries and enclosures.
- Components added to the Product after shipment from Cummins.
- Block heaters are warranted for one (1) year from date in service

Please contact your local Cummins Sales and Service for clarification concerning these limitations.

Extended Warranty

Cummins Inc. offers several levels of Extended Warranty Coverage (**Base Engine Only**). Please contact your local Cummins Distributor for details.

Cummins Right to Failed Components:

Failed components claimed under warranty remain the property of Cummins. Cummins has the right to reclaim any failed component that has been replaced under warranty.

THE WARRANTIES SET FORTH HEREIN ARE THE SOLE WARRANTIES MADE BY CUMMINS INC. IN REGARD TO THE PRODUCT. CUMMINS INC. MAKES NO OTHER WARRANTIES, EXPRESS OR IMPLIED, OR OF MERCHANTABILITY OR FITNESS FOR A PARTICULAR PURPOSE. IN NO EVENT IS CUMMINS INC. LIABLE FOR INCIDENTAL OR CONSEQUENTIAL DAMAGES.

This limited warranty shall be enforced to the maximum extent permitted by applicable law. This limited warranty gives the owner specific rights that may vary from state to state or from jurisdiction to jurisdiction.

See the Cummins Inc. warranty bulletins for additional base engine warranty details: [US & Canada: 3381321](#)
[International: 3381322](#).



Cummins fire pump drive engines have been manufactured under the controls established by a Bureau Veritas Certification approved management system that conforms with ISO 9001:2015.



Cummins Sales and Service
875 Lawrence Drive
DePere, Wisconsin 54115

www.cumminsfirepower.com



Table of Contents

Section 1 - Safety

1.1 Introduction	1-1
1.2 General Safety Precautions	1-1
1.3 Use of Advisory and Cautionary Statements	1-1
1.3.1 Advisory Statements	1-1
1.3.2 Cautionary Statements	1-2

Section 2 - Description

2.1 Introduction	2-1
2.2 Fire Pump Controller	2-1
2.3 Fire Pump Digital Panel (FPDP)	2-4
2.3.1 Engine STOP Button	2-5
2.3.2 Customer Access Port	2-5
2.3.3 Diagnostics Connector	2-5
2.3.4 Engine ECM Power Supply	2-5
2.3.5 Tachometer	2-5
2.3.6 Battery "A" and "B" Voltmeters	2-5
2.3.7 SCREEN Soft Key	2-5
2.3.8 RESET/STOP Switch	2-5
2.3.9 IDLE Soft Key	2-5
2.3.10 Crank Battery A and B Momentary Start Switches	2-5
2.3.11 ECM A/ECM B Selector Switch and Indicator Lamps	2-5
2.3.12 Automatic or Manual Mode of Operation Selector Switch and Indicator Lamps	2-6
2.3.13 MENU Soft Key	2-6
2.3.14 Hour Meter	2-6
2.3.15 Engine Oil Pressure Gauge	2-6
2.3.16 Coolant Temperature Gauge	2-6
2.4 FPDP Informational Displays	2-6
2.4.1 Fault Code Warning Displays	2-6
2.4.1.1 Yellow Warning Indicators	2-6
2.4.1.2 Red Warning Indicators	2-7
2.4.2 Overspeed Warning Indicator	2-8
2.4.3 VSPLC Information and Warnings	2-8
2.4.4 DPEM Fault Screens	2-9
2.5 Electronic Control Module (ECM)	2-10
2.6 Digital Panel Expansion Module (DPEM) (Optional)	2-10
2.7 Fuel Supply and Drain	2-11
2.8 High Pressure Injection (HPI) Fuel System	2-11
2.9 Fuel Cooling System	2-12
2.10 Air Intake System	2-13
2.11 Cooling Water System	2-14
2.12 Engine Oil System	2-16
2.13 Exhaust System	2-17

Table of Contents

Section 3 - Installation

3.1 Introduction	3-1
3.2 Receiving and Handling	3-1
3.3 Site Preparation	3-1
3.4 Drive Shaft Installation	3-1
3.5 Fuel Supply Installation	3-2
3.6 Battery Installation	3-3
3.7 Signal and Control Installation	3-4
3.7.1 FPDP Interface Terminal Strip	3-4
3.7.2 Battery Charger Interface	3-6
3.8 Coolant System Preparation	3-6
3.9 Radiator Cooling System Inspection	3-7
3.10 Lubricating Oil System Preparation	3-7
3.11 Variable Speed Pressure Limiting Control (VSPLC) Preparation	3-8
3.12 Pre-Start Inspections	3-8
3.13 Engine Monitoring	3-8
3.14 Field Acceptance Testing	3-9

Section 4 - Operation

4.1 Introduction	4-1
4.2 Starting and Stopping Procedures	4-1
4.2.1 Local Starting/Stopping Procedure	4-1
4.2.2 Emergency Starting/Stopping Procedure	4-1
4.3 Fire Pump Digital Panel (FPDP) Screens and Adjustments in Automatic Mode	4-3
4.3.1 The SCREEN Soft Key	4-3
4.3.2 The MENU Soft Key - Settings Menu	4-4
4.3.2.1 ENGINE SETUP Screen	4-4
4.3.2.2 OVERSPEED TEST Screen	4-6
4.3.2.3 IMPERIAL/SI VALUES Screen	4-7
4.3.2.4 ANALOG VALUES Screen	4-7
4.3.2.5 AUTOSWITCH Screen	4-8
4.3.2.6 FAULT CODES Screen	4-8
4.3.2.7 RPM ADJUSTMENT Screen	4-9
4.3.2.8 DPEM (Optional)	4-9
4.4 FPDP Screens and Adjustments in Manual Mode - IDLE Soft Key	4-10
4.5 Engine/Turbocharger Cool Down	4-10
4.5.1 Automatic Shutdown - Cool Down Timer	4-11
4.5.2 Automatic Shutdown - Engine Protection	4-11
4.5.3 Manual Shutdown - From the Fire Pump Controller	4-11
4.5.4 Manual Shutdown - From the FPDP	4-11

Section 5 - Maintenance

5.1 Introduction	5-1
5.2 Engine Operation Reports	5-1
5.3 Weekly Maintenance	5-3
5.3.1 General	5-3
5.3.2 Air Cleaner Filter and Piping	5-3
5.3.3 Cooling System	5-3
5.3.4 Engine Oil System	5-4
5.3.5 Fuel System	5-5
5.3.6 Engine Exhaust System	5-5
5.3.7 Electrical Supply and Controls	5-5
5.3.8 Crankcase Ventilation Hose	5-5



Table of Contents

5.3.9 Batteries	5-5
5.3.10 Engine Test Run	5-6
5.3.11 Engine Operation Checks	5-6
5.3.11.1 Crank Termination Setpoint	5-6
5.3.11.2 Engine Speed Adjustment	5-6
5.3.12 Engine Coolant Heater	5-6
5.4 Annual Maintenance	5-7
5.4.1 Electrical Components	5-7
5.4.2 Turbocharger Mounting Nuts	5-7
5.4.3 Engine Supports	5-7
5.4.4 Fuel Pumps and Filters	5-7
5.4.5 Engine Oil and Filter	5-8
5.4.6 Drive Shaft	5-10
5.4.7 Coolant Pump/Alternator Belt	5-10
5.4.8 Radiator Pressure Test	5-10
5.4.9 Turbocharger	5-11
5.5 Every Two Years	5-11
5.5.1 Coolant Pump	5-11
5.5.2 Radiator Cooling System	5-11
5.6 Every Four Years	5-13
5.6.1 Coolant Thermostat Removal/Installation	5-14
5.6.2 Coolant Pump/Alternator Belt Replacement	5-14
5.6.3 Radiator Cooling System	5-15
Section 6 - Troubleshooting	
6.1 Introduction	6-1
6.2 Engine Will Not Start	6-2
6.3 Engine Cranks But Will Not Start	6-3
6.4 Engine Starts But Continues to Crank	6-5
6.5 Engine Will Not Stop	6-6
6.6 Low Battery Voltage	6-7
6.7 Fault Code Charts - CFP11E, CFP15E/EVS, CFP23E/EVS, CFP30E	6-8
Section 7 - Component Parts and Assemblies	
7.1 Ordering Parts	7-1
7.2 Repairs and Technical Service	7-1
7.3 Recommended Spare Parts Inventory	7-1
7.4 Engine Data Sheet and Torque Values	7-1
CFP23E Engine Data	7-2
Cap Screw Markings and Torque Tables	7-7
7.5 CFP23E/EVS Radiator-cooled Assembly Drawings	7-9





This page is intentionally left blank.





Section 1 - Safety

1.1 Introduction

Cummins engine manuals should be considered part of the equipment. Keep the manuals with the equipment. If the equipment is traded or sold, give the manuals to the new owner.

All personnel responsible for operation and maintenance of the equipment should read and thoroughly understand this manual.

1.2 General Safety Precautions

Read and understand all of the safety precautions and warnings before performing any repair. Special safety precautions are included in the procedures when they apply. This list contains the general safety precautions that **must** be followed to provide personal safety:

- Perform a walk around inspection and alert all area personnel that the equipment will be starting before manual operation.
- Do not operate faulty or damaged equipment. Ensure that all hoses, pipe connections, clamps and guards are in place and securely fastened. Electrical components should be kept in good working condition and repaired immediately by qualified personnel.
- After performing maintenance, remove all tools and foreign materials and reinstall and securely fasten ALL guards, covers, and protective devices.
- Exposed in-running belt nips can cause severe personal injury or dismemberment. Ensure that guards are in place and securely fastened before operation.
- Rotating drive shafts can lacerate, dismember, or cause strangulation. Keep hands, body parts,

long hair, or loose-fitting clothing clear at all times.

- Never attempt to manually clean a machine while it is operating or in standby mode.
- Never open ports on tanks or piping while the engine is operating. Contact with pressurized agents can cause severe personal injury.
- Relieve all pressure in the air, oil, and the cooling systems before any lines, fittings, or related items are removed or disconnected.
- Engine fuel is flammable when in contact with electrical spark or flame sources. Remove all sources of spark or flame from the work area.
- Always use the same fastener part number (or equivalent) when replacing fasteners.
- Some state and federal agencies in the United States have determined that used engine oil can be carcinogenic and can cause reproductive toxicity. Dispose of waste oil in accordance with applicable requirements.

1.3 Use of Advisory and Cautionary Statements

1.3.1 Advisory Statements

Advisory statements used throughout this manual call attention to special information and correct operating procedures. These Advisory statements are delineated by the terms “NOTE” and “IMPORTANT” in uppercase letters:

NOTE: *A general advisory statement relating to equipment operation and maintenance procedures.*

IMPORTANT: *A specific advisory statement intended to prevent damage to the equipment or associated components.*



1.3.2 Cautionary Statements

Cautionary statements highlight particular safety precautions pertaining to personal injury and/or damage to the equipment. Cautionary statements are always preceded by the following symbols:

 **WARNING**

Indicates the presence of a hazard which CAN cause severe personal injury.

 **CAUTION**

Indicates the presence of a hazard which CAN cause personal injury, or cause equipment damage.

Section 2 - Description

2.1 Introduction

This manual contains information for the correct operation and maintenance of a Cummins fire pump drive engine. Read and follow all safety instructions in [Section 1 - Safety](#). Keep this manual with the equipment. If the equipment is traded or sold, give the manual to the new owner.

Cummins fire pump drive engines have been designed and tested in accordance with National Fire Protection Association (NFPA) 20 guidelines.

No deviations are permitted without prior written approval. These engines are to be used only for fire protection applications. [Figure 2-1](#) and [Figure 2-2](#) provide visual descriptions of the engine components for this fire pump drive engine.

Cummins Inc. reserves the right to make changes at any time. If any differences are found between an engine and the information in this manual, contact your local Cummins Authorized Repair Location.

The latest technology and the highest quality components were used to produce this engine. When replacement parts are needed, we recommend using only genuine Cummins parts.



CAUTION

Injury may result and warranty is voided if fuel rate, revolutions per minute (RPM), or altitudes

exceed published maximum values for this model and application.

2.2 Fire Pump Controller

The fire pump controller starts the engine automatically when the Fire Pump Digital Panel (FPDP) is in automatic mode and a remote fire demand signal is received. The fire pump controller automatically shuts down the engine when the fire demand signal is discontinued. The fire pump controller is optionally supplied by Cummins Sales and Service or Cummins Inc.

NOTE: *With the fire pump controller in **manual** mode, starting and stopping the fire pump drive engine can be controlled by the FPDP, located on the fire pump drive engine itself.*



CAUTION

Upon turning the fire pump controller to OFF, the fire pump drive engine may continue to run at a reduced speed to cool the engine down. To stop the fire pump drive engine at this point - in the case of an emergency - press the Engine STOP button on the FPDP rather than on the pump controller.



Description

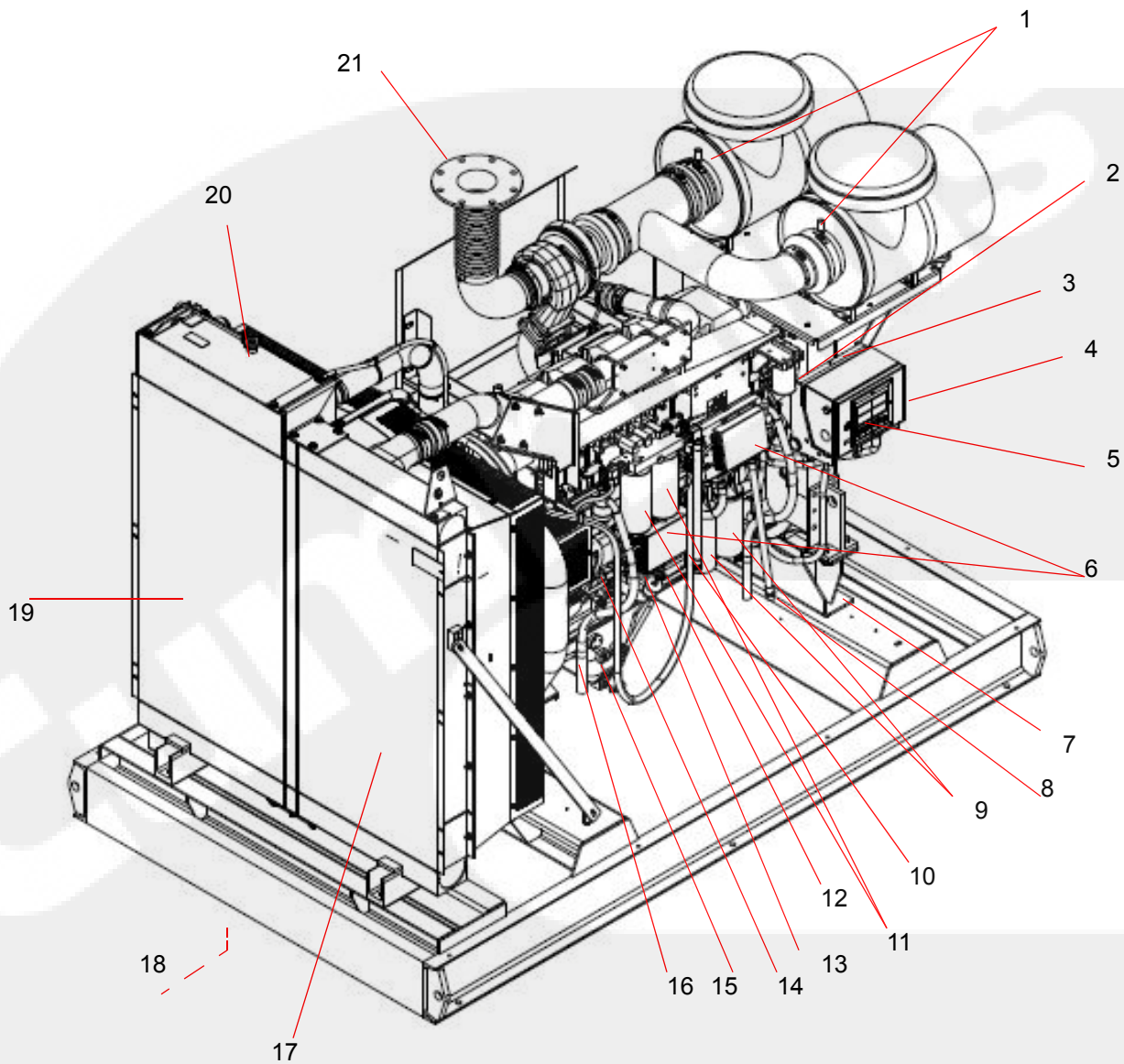

- | | | | |
|-----|-------------------------------------|-----|----------------------------|
| 1. | Air Cleaner Service Indicator (2) | 12. | Oil Level Dipstick |
| 2. | Coolant Filter | 13. | Oil Fill Port |
| 3. | ESN and Engine Speed Setting Decals | 14. | Alternator |
| 4. | Manual Start Instruction Decal | 15. | Oil Drain Valve |
| 5. | Fire Pump Digital Panel (FPDP) | 16. | Crankcase Ventilation Hose |
| 6. | Electronic Control Modules (ECMs) | 17. | Charge Air Cooler (CAC) |
| 7. | Engine Supports | 18. | Coolant Drain (not shown) |
| 8. | Fuel Return Line | 19. | Jacket Water Radiator |
| 9. | Oil Filter (2) | 20. | Coolant Fill Cap |
| 10. | Fuel Supply Line | 21. | Exhaust Flex Connection |
| 11. | Fuel Filter/Water Separator (2) | | |

Figure 2-1 Engine Components - Fire Pump Digital Panel (FPDP) Side

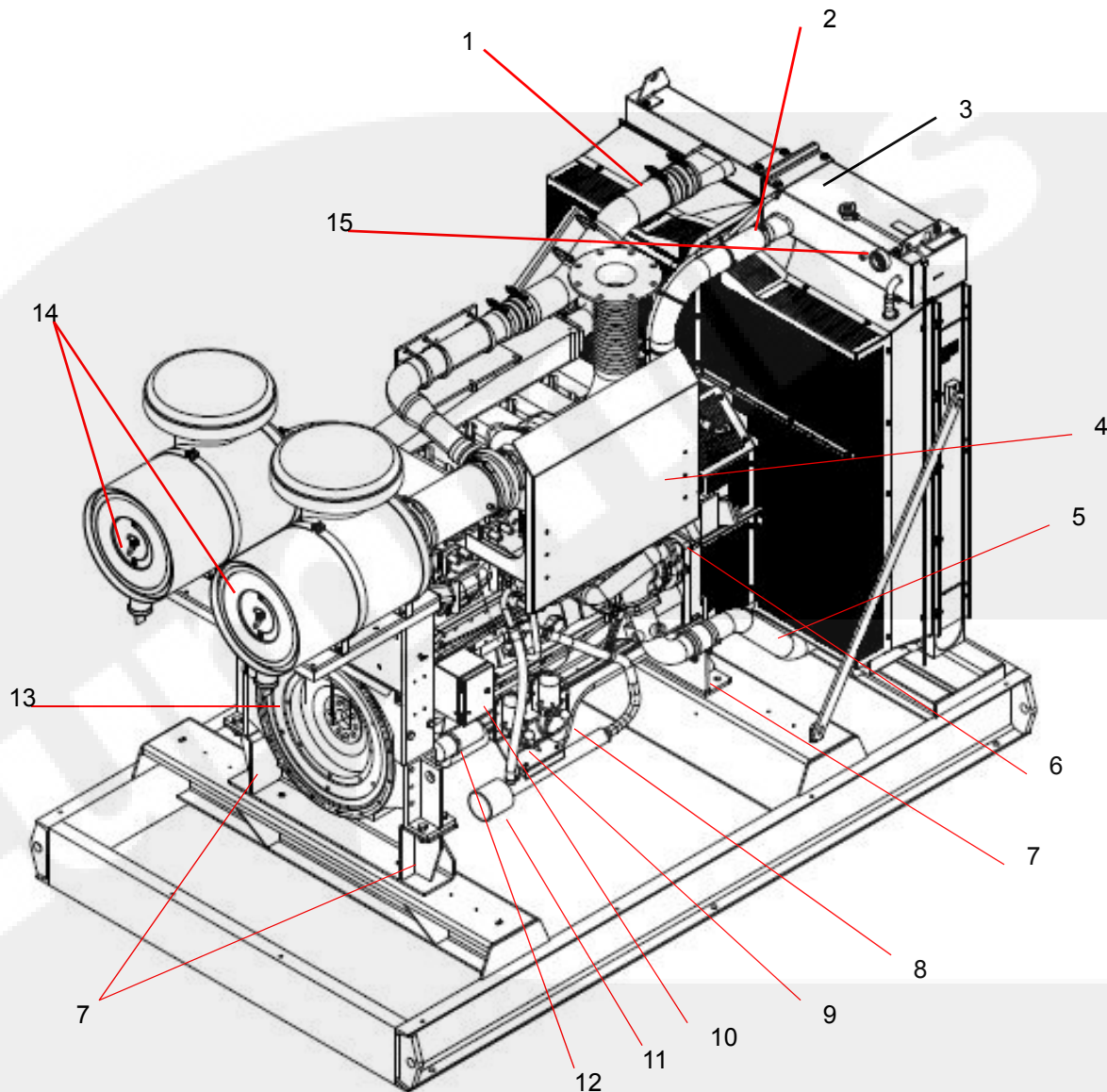

- | | |
|---------------------------------|--------------------------------------|
| 1. Charge Air Cooler (CAC) Tube | 9. Battery Starter Contactor A |
| 2. Upper Coolant Hose | 10. Terminal Box |
| 3. Coolant Expansion Tank | 11. Engine Coolant Heater |
| 4. Manifold Heat Shield | 12. Starter Motor |
| 5. Lower Coolant Hose/Tube | 13. Flywheel Housing |
| 6. Coolant Pump | 14. Air Cleaner Assembly (2) |
| 7. Engine Supports | 15. Expansion Tank Level Sight Gauge |
| 8. Battery Starter Contactor B | |

Figure 2-2 Engine Components - Turbocharger Side

Description

2.3 Fire Pump Digital Panel (FPDP)

The FPDP control panel (shown in Figure 2-3) is mounted on the left-hand side (or right-hand side - optional) of the flywheel end of the engine and contains controls for starting the engine, monitoring

engine performance, and controlling fire pump drive engine operation.

In **manual** mode, the FPDP and the Electronic Control Module (ECM) remain active as long as battery power is available. In **automatic** mode, starting and stopping of the engine is controlled by the fire pump controller.

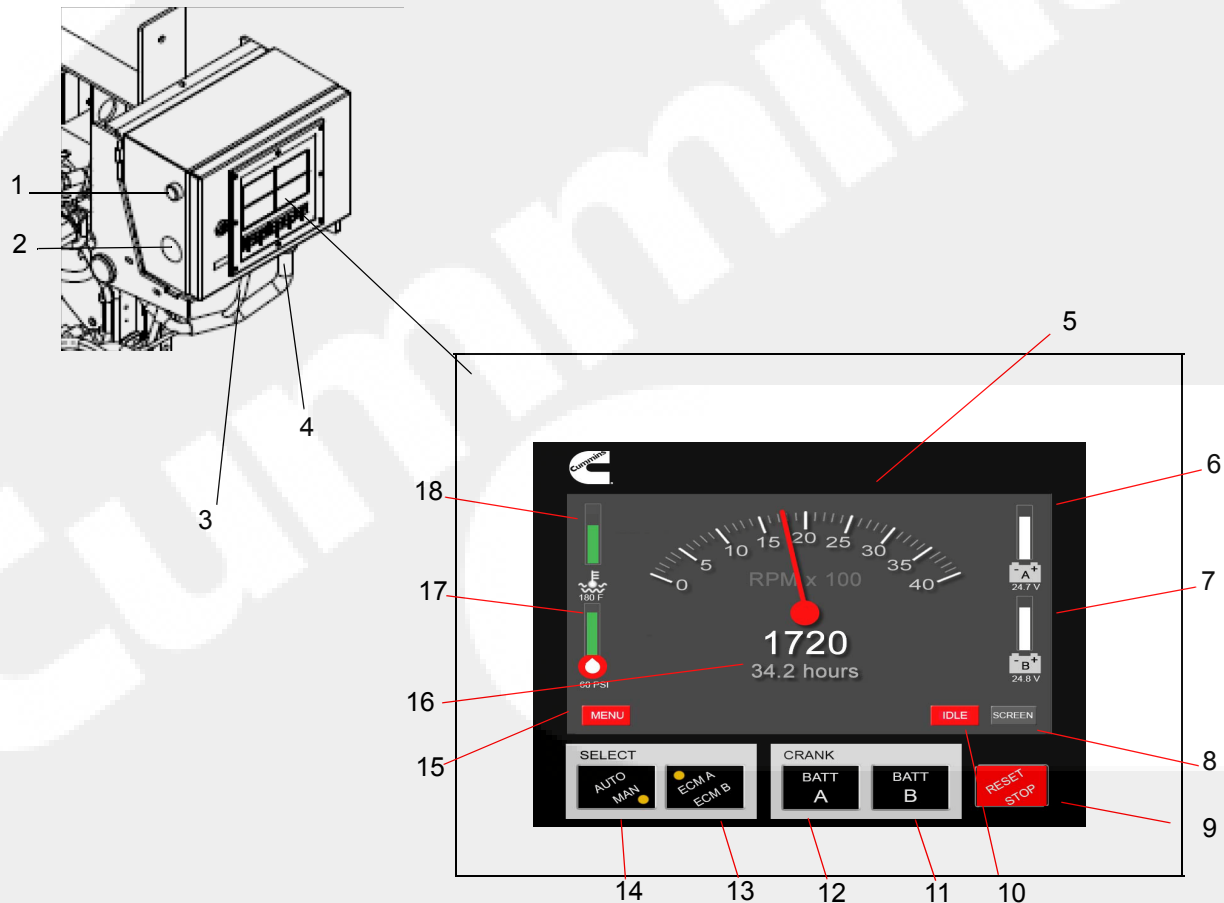

- | | |
|--|---|
| 1. Engine STOP Button | 11. Crank Battery B Momentary Start Switch |
| 2. Customer Access Port | 12. Crank Battery A Momentary Start Switch |
| 3. Diagnostics Connector | 13. ECM A/ECM B Selector Switch and Indicator Lamps |
| 4. Engine ECM Power Supply | 14. AUTO/MAN Mode Selector Switch and Indicator Lamps |
| 5. Tachometer | 15. MENU Soft Key |
| 6. Battery "A" Voltmeter | 16. Hour Meter |
| 7. Battery "B" Voltmeter | 17. Engine Oil Pressure Gauge |
| 8. SCREEN Soft Key | 18. Coolant Temperature Gauge |
| 9. RESET/STOP Switch | |
| 10. IDLE Soft Key (not applicable to mechanical engines) | |

Figure 2-3 FPDP Control Panel

2.3.1 Engine STOP Button

The Engine STOP Button (1) is located on the left side of the FPDP enclosure and is used to stop the operation of the engine in either manual or automatic mode. The button must be pressed and held until the engine has shut down.

NOTE: Upon release of the Engine STOP Button, the fire pump drive engine will attempt to restart, if there is still a "pump on demand" signal present from the fire pump controller. The engine must also be stopped at the fire pump controller.

2.3.2 Customer Access Port

The customer access knock-out (2) is located on the left side of the FPDP for ease of access. This is the only 1 in. (25.4 cm) knock-out provided for the pump controller interconnect.

IMPORTANT: If additional holes are placed in the FPDP, all warranty on the fire pump drive engine will be void.

2.3.3 Diagnostics Connector

The Diagnostics Connector (3) is located on the bottom of the FPDP enclosure and is strictly for use by Cummins service personnel.

2.3.4 Engine ECM Power Supply

The Engine ECM Power Supply plug-in (4) is located on the lower side of the FPDP to provide unswitched battery power to both ECM A and ECM B.

2.3.5 Tachometer

The Tachometer (5) displays the engine speed in revolutions per minute (RPM) whenever the engine is operating.

2.3.6 Battery "A" and "B" Voltmeters

The Battery "A" (6) and Battery "B" (7) Voltmeters display the charge status - or Voltage Direct Current (VDC) - of the relative battery connections.

2.3.7 SCREEN Soft Key

The SCREEN soft key (8) allows the user to switch to a detailed pop up list of additional analog values (when available): exhaust temperature; cooling loop temperature; cooling loop differential pressure; and J1939 values including: oil temperature; intake manifold temperature; and intake manifold pressure.

2.3.8 RESET/STOP Switch

The RESET/STOP Switch (9) serves multiple purposes:

- To shut off the engine by removing the ECM key-switch/Fuel Shutoff (FSO) valve until the engine speed decelerates to 0 RPM.
- To reset the fire pump drive engine after an over-speed fault has been activated, allowing subsequent restarts of the fire pump drive engine.

2.3.9 IDLE Soft Key

The IDLE soft key (10) allows the user to run an electronic engine at a reduced speed while the FPDP is in manual mode (See the [IDLE Soft Key Section in the Operation Section](#)). When the FPDP AUTO/MAN selector switch is in the MAN position (manual mode), the IDLE soft key will appear and display in red. When the engine idle command is active, the IDLE soft key will display in green.

NOTE: The IDLE soft key is only intended to be used for commissioning or service events.

2.3.10 Crank Battery A and B Momentary Start Switches

The CRANK BATT A (12) and CRANK BATT B (11) momentary start switches engage the starter when the FPDP is in MANUAL mode.

CRANK BATT A energizes battery contactor A and CRANK BATT B energizes battery contactor B. Both CRANK BATT A and CRANK BATT B buttons can be energized at the same time in the event both batteries are weak.

2.3.11 ECM A/ECM B Selector Switch and Indicator Lamps

The ECM A / ECM B selector switch and indicator lamps (13) illuminate in yellow, indicating which ECM is being used to control the engine.

If ECM A (normal position) is selected, ECM A is monitoring and controlling the engine.

If ECM B (alternate position) is selected, ECM B is monitoring and controlling the engine, and the FPDP will indicate that the engine is operating on the alternate ECM.

Description

2.3.12 Automatic or Manual Mode of Operation Selector Switch and Indicator Lamps

The AUTO/MAN selector switch and indicator lamps (14) illuminate in yellow, indicating the operational state of the FPDP.

The MAN selector switch (for manual operation) is only to be selected for engine setup, testing, and emergency and maintenance procedures. When the FPDP is in manual mode, the ECM keyswitch/FSO and raw water solenoids are always activated, except under an overspeed condition.

The AUTO selector switch (for automatic operation) is the normal state of the FPDP, in which the fire pump controller starts and stops the engine. In automatic mode, the fire pump drive engine shuts down or enters engine cool down upon loss of a signal from the fire pump controller.

2.3.13 MENU Soft Key

The MENU soft key (15) on the FPDP display allows the user to open the menu options. A complete list of FPDP screens and their functionality is outlined in the [Operation Section](#) of this manual.

2.3.14 Hour Meter

The Hour Meter (16) maintains a running total of the hours of engine operation (run time).

2.3.15 Engine Oil Pressure Gauge

Based on user parameter screen display selection, the Engine Oil Pressure Gauge (17) displays the engine oil pressure in pounds per square inch (PSI) or kPa. The Engine Oil Pressure Gauge displays by default in three different colors:

- green - when the engine oil pressure is greater than 25 PSI (172 kPa);
- yellow - when the engine oil pressure is between 17 PSI (117 kPa) and 25 PSI (172 kPa); and
- red - when the engine oil pressure is below 16 PSI (110 kPa). *NOTE: Engine oil pressure displayed in red will also be accompanied by a low oil pressure fault. Refer to TB-4.*

2.3.16 Coolant Temperature Gauge

Based on user parameter screen display selection, the Coolant Temperature Gauge (18) displays the engine coolant temperature in degrees Fahrenheit or

degrees Celsius. The Coolant Temperature Gauge displays in three different colors:

- green - when the coolant temperature is between 100-199 °F (38-93 °C);
- yellow - when the coolant temperature is between 200-211 °F (93-100 °C) OR below 100 °F (38 °C). *NOTE: when the coolant temperature is below 100 °F (38 °C), the yellow gauge will also be accompanied by a low coolant temperature fault. Refer to TB-312.; and*
- red - when the coolant temperature is greater than 212 °F (100 °C). *NOTE: the red gauge will also be accompanied by a high coolant temperature fault. Refer to TB-5.*

2.4 FPDP Informational Displays

2.4.1 Fault Code Warning Displays

Fault codes diagnosed by the ECM are displayed in a yellow or red International Organization for Standardization (ISO) symbol and/or overlay box which lies atop the tachometer signal (the engine speed is still digitally displayed) to alert the operator to service the engine as soon as possible. Only the first seven active ECM faults will be displayed in the overlay.

NOTE: To remove the overlay box from atop the tachometer, press the SCREEN Soft Key.

2.4.1.1 Yellow Warning Indicators

The yellow ISO symbol (shown in [Figure 2-4](#)) or the yellow ISO symbol AND a large yellow box covering the tachometer (shown in [Figure 2-5](#)) indicate an engine malfunction that requires timely operator attention.



Figure 2-4 Yellow Warning Indicator ISO Symbol Only

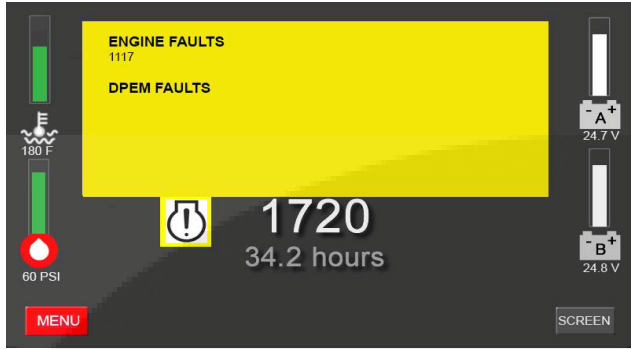

Figure 2-5 Yellow Warning Indicator Symbol and Overlay Box ISO

When applicable, the FPDP may display the Yellow Warning Indicator for any one of the following operational issues:

- The ECM has sensed a **non-mission disabling fault**. A three- or four-digit diagnostic fault code will display on the FPDP which can then be used to help diagnose the engine malfunction. Refer to the Fault Code Chart in the [Fault Codes Section](#) or contact your local Cummins Distributor.
- **Communications have been lost with the ECM**. The FPDP communicates with electronically-controlled engines via J1939. As shown in [Figure 2-6](#), if communications are lost, "J1939 Lost" will appear on the top left of the screen. The warning lamp will also illuminate and the text "NWF" (which stands for "Network Failure") will replace all digital J1939 values, except the tachometer, which will revert to using a mechanical speed sensor for engine speed detection.

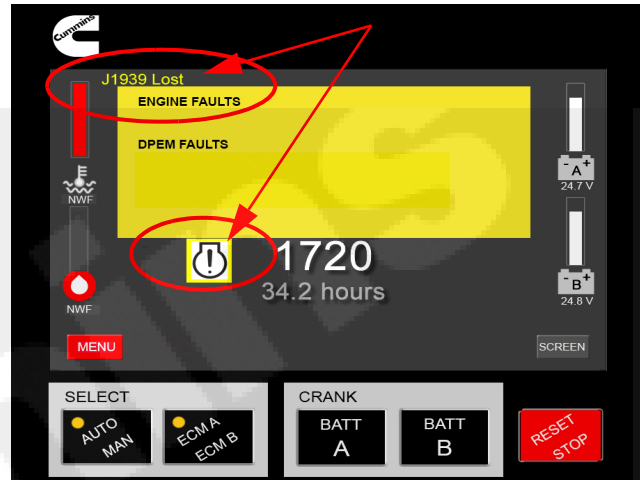

Figure 2-6 Loss of J1939 Communications

- **Communications have been lost with the Digital Panel Expansion Module (DPEM)**. As shown in [Figure 2-7](#), "DPEM Lost" will appear on the FPDP User Interface Screen if communications between the FPDP and DPEM are compromised.

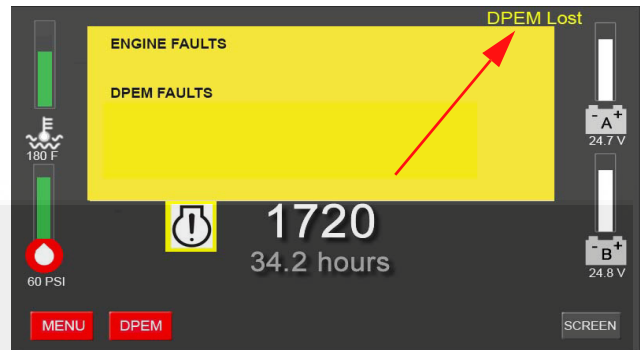

Figure 2-7 DPEM Lost Fault Screen

- A **DPEM alarm** has been activated.
- The pump discharge **pressure is greater than 115%** of the desired pressure in a Variable Speed Pressure Limiting Control (VSPLC)-enabled system (see [Figure 2-12](#)).

2.4.1.2 Red Warning Indicators

The red ISO symbol (shown in [Figure 2-8](#)) or the red ISO symbol AND a large red box covering the tachometer (shown in [Figure 2-9](#)) indicate an engine malfunction that requires immediate and decisive operator response. The FPDP will display the Red

Description

Warning Indicator when the ECM has sensed a fuel system or ECM-specific diagnostic fault. Refer to the Fault Code Chart in the [Fault Codes Section](#) or contact your local Cummins Distributor.

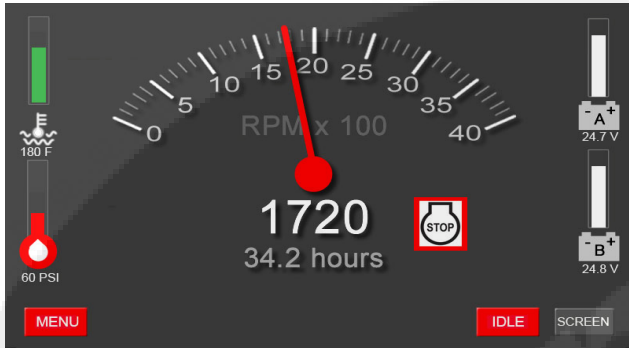

Figure 2-8 Red Warning Indicator ISO Symbol Only

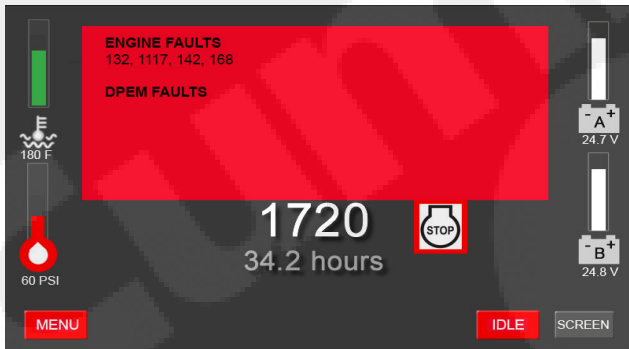

Figure 2-9 Red Warning Indicator ISO Symbol and Overlay Box

2.4.2 Overspeed Warning Indicator

As shown in [Figure 2-10](#), “ENGINE OVERSPEED” flashing in red at the top of the FPDP screen indicates that the engine has exceeded its rated RPM and that possible damage to the sprinkler system may occur. This malfunction requires immediate and decisive operator response. A three- or four-digit diagnostic fault code will display on the FPDP which can then be used to help diagnose the engine mal-

function. Refer to the Fault Code Chart in the [Fault Codes Section](#) or contact your local Cummins Distributor.

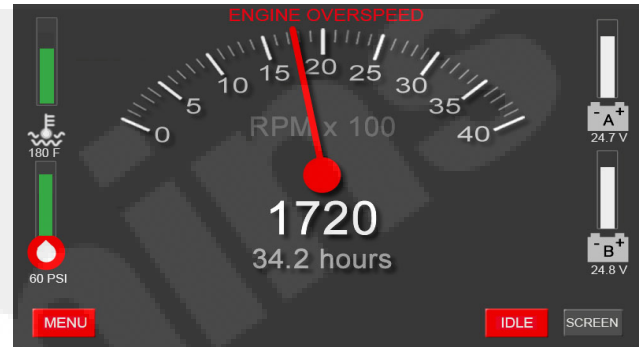

Figure 2-10 Overspeed Warning Indicator

2.4.3 VSPLC Information and Warnings

IMPORTANT: VSPLC capability is FM-approved and the fire pump drive engine must be ordered from Cummins as a variable speed engine; specific manufacturing tests are required for fixed and variable speed fire pump drive engines prior to installation.

VSPLC is a controls feature in which the FPDP varies the engine speed in an attempt to maintain a constant pump discharge pressure. The allowable speed range for a VSPLC engine is from low speed idle (LSI) to rated speed where LSI = 1200 RPM on all engines except the CFP15E (in which LSI = 1400 RPM).

The rated speed can be slightly increased or decreased, just as the fixed speed engine setpoint can be, by a Cummins representative.

As shown in [Figure 2-11](#), “VSPLC Active” and the VSPLC discharge pressure will be displayed in white at the bottom of the screen when VSPLC is enabled and active.



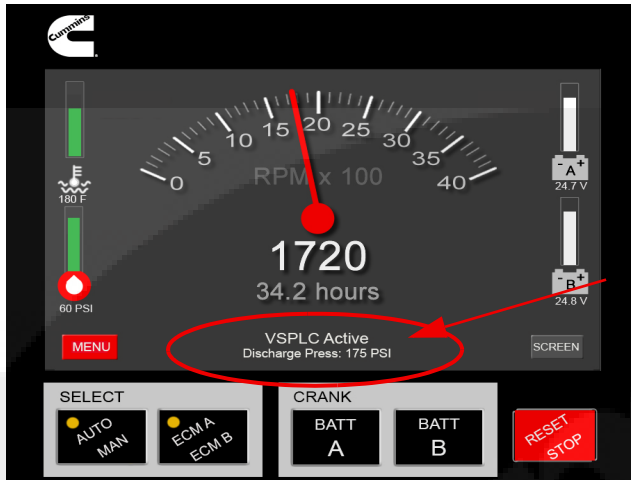

Figure 2-11 VSPLC Active Screen - White (Sample)

If VSPLC is active and the pump discharge pressure is greater than 115% of the setpoint:

- “VSPLC Active” and the VSPLC discharge pressure will be displayed in yellow at the bottom of the screen (shown in Figure 2-12)
- A yellow engine warning lamp icon will also appear on the screen (shown in Figure 2-12)
- A yellow overlay box will appear atop the tachometer signal (the engine speed is still digitally displayed) to alert the operator to service the engine at the earliest convenience

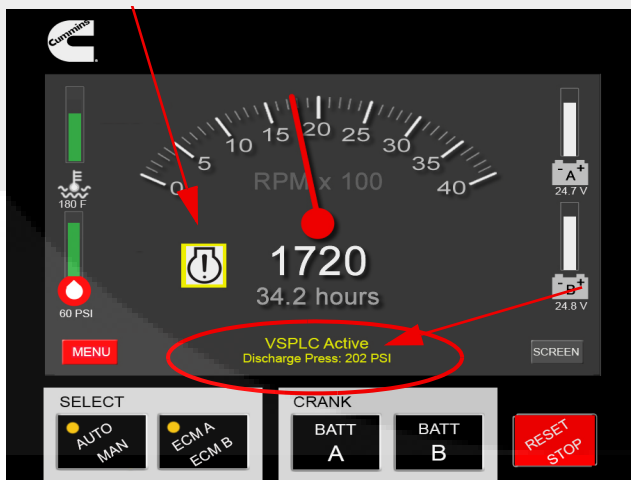

Figure 2-12 VSPLC Active Screen - Yellow (Sample)

In order to satisfy fire pump commissioning requirements, the engine will run at fixed speed only when the FPDP is in manual mode with TB-1 off. As shown in Figure 2-13, “VSPLC Inactive” and the VSPLC discharge pressure will be displayed in red at the bottom of the screen when VSPLC is not enabled and/or not active.



Figure 2-13 VSPLC Inactive Screen - Red (Sample)

NOTE: If TB-1 is activated from the fire pump controller during this time, the VSPLC mode will activate and control the engine speed based on the pump discharge pressure. “VSPLC Active” and the VSPLC discharge pressure will revert back to white at the bottom of the screen (shown in Figure 2-11).

2.4.4 DPEM Fault Screens

When an analog input parameter crosses the alarm setpoint or a switched input is active, the FPDP may display the DPEM fault one of two ways:

- **From the FPDP** - As shown in Figure 2-14, the warning symbol will illuminate and the overlay will activate in yellow with the text of the active fault.

Description

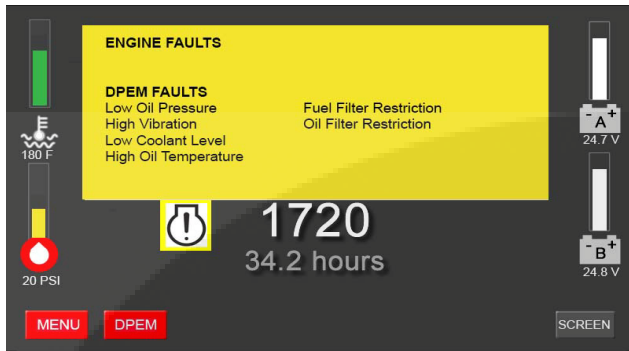

Figure 2-14 DPEM Fault Screen (Sample)

- **From the DPEM/remote location** - The terminal block interface inside of the DPEM has been created for connection to monitor alarms remotely. There is an LED next to each terminal block that will also illuminate if the relay is commanded closed.

Each set of four relays has a common dry contact associated for integration flexibility:

- Terminal Blocks 13-16 (R1-R4) are dedicated to switched inputs, with TB-17 being the common contact
- Terminal Blocks 18-21 (R5-R8) are dedicated to temperature inputs, with TB-22 being the common contact
- Terminal Blocks 23-26 (R9-R12) are dedicated to pressure inputs, with TB-27 being the common contact
- Terminal Blocks 28-31 (R13-R16) are dedicated to additional pressure inputs or J1939 setpoints, with TB-32 being the common contact

As shown in [Figure 2-15](#), “DPEM Lost” will appear on the FPDP screen if communications between the FPDP and DPEM are compromised.

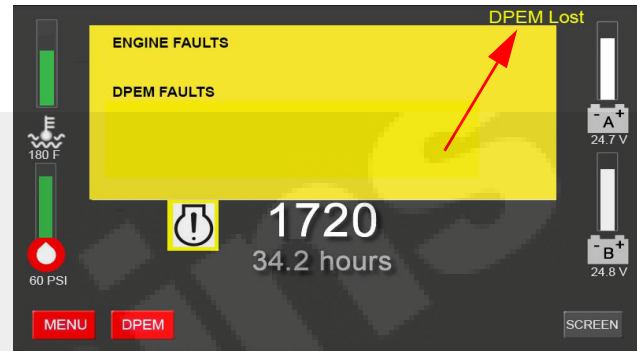

Figure 2-15 DPEM Lost Fault Screen (Sample)

2.5 Electronic Control Module (ECM)

The engine Operation and Maintenance manual provides detailed information about the ECM(s).

A second ECM is installed on electronic engines to satisfy the NFPA 20 requirement for a redundant means of electronic fuel injection. Switching of the sensor inputs and outputs to the respective ECM is controlled through the FPDP either manually (by means of the ECM A/B Selector Switch on the panel) or through an automated process called Autoswitching (refer to the Operation section of this manual for more information on Autoswitching).

NOTE: *Cummins electronically-controlled “engines” normally enable ECMs with derate and shutdown protection. Fire pump drive engines have the derates and shutdowns and disabled. Fire pump drive engines will run to destruction, making preventive maintenance even more essential for a fire pump drive engine.*

2.6 Digital Panel Expansion Module (DPEM) (Optional)

The Digital Panel Expansion Module (DPEM) is an optional electronic device that works in conjunction with the FPDP to provide options for monitoring and alarming custom inputs. As shown in [Figure 2-16](#), the DPEM is housed in a 316 stainless steel enclosure and contains a series of terminal blocks for customer connection to specified alarm points. One DPEM can be configured for any or all of the following:

- Four switched inputs;
- Three temperature inputs;

- One exhaust temperature input;
- Six pressure inputs; and/or
- J1939 parameters (when applicable).

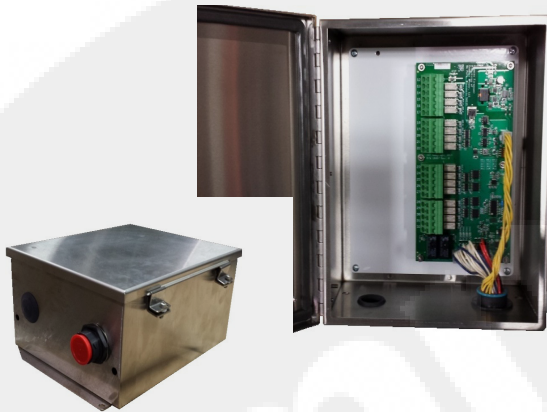

Figure 2-16 Digital Programming Expansion Module (DPEM)

2.7 Fuel Supply and Drain

As shown in Figure 2-1, the fuel supply and return connections are centrally located on the FPDP side. Refer to the [Engine Data Sheet](#) for the maximum allowable fuel tank supply locations above the fuel pump.

2.8 High Pressure Injection (HPI) Fuel System

The CFP23E comes with a gear type fuel pump driven by the engine.

As shown in [Figure 2-17](#), the fire pump drive engine is equipped with an electronic fuel system that delivers precise fuel quantities with precise injection timing at high injection pressures. The system consists of high-pressure unit injectors and the fuel supply system uses various system monitoring sensors. The system is controlled by ECMs for fueling and timing based on temperature, altitude, pressure, and throttle position.

With the HPI fuel system, fuel priming is required for conditions such as: initial start-up, running out of fuel, and maintenance of the fuel system components (e.g., filter change).

Description

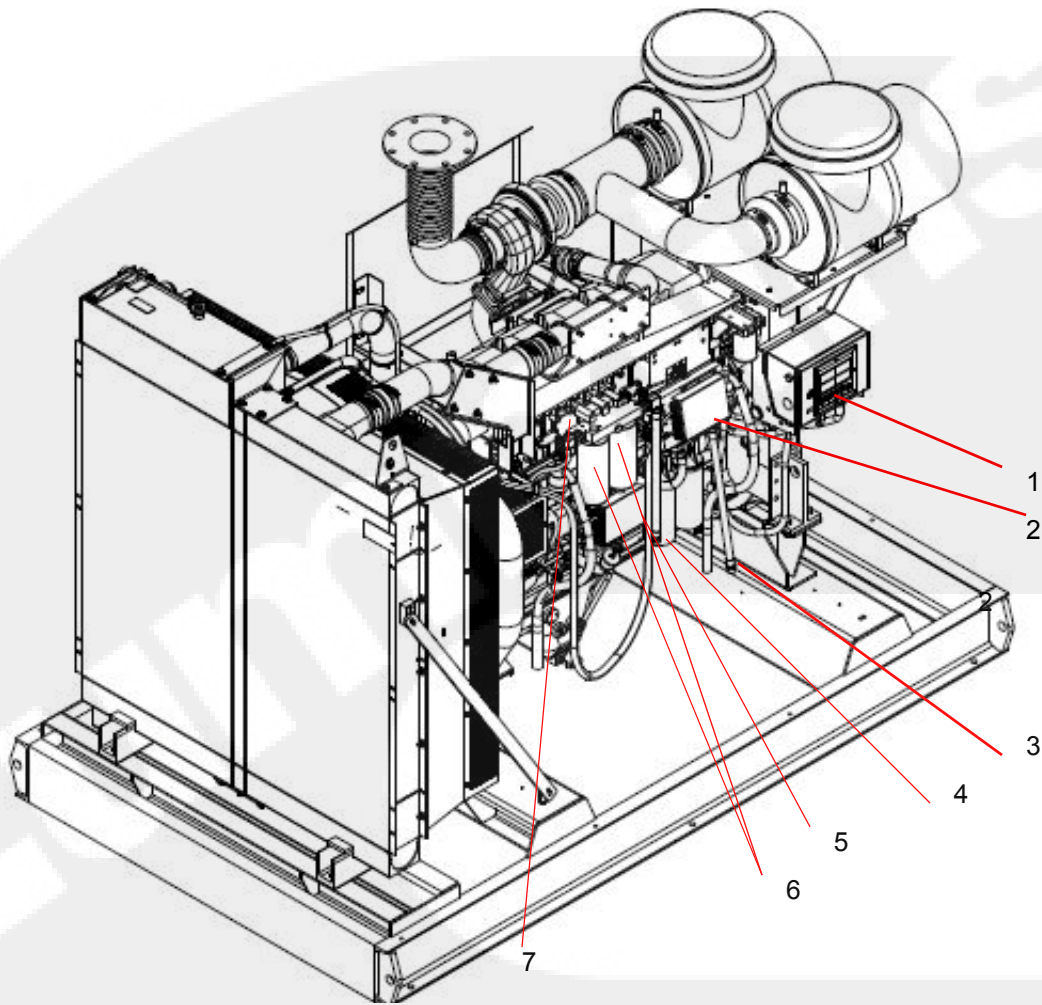

- | | |
|-----------------------------------|---------------------------|
| 1. Fire Pump Digital Panel (FPDP) | 5. ECM A |
| 2. ECM B | 6. Fuel Filter/Separators |
| 3. Fuel Return Line | 7. Fuel Pump |
| 4. Fuel Supply Line | |

Figure 2-17 Fuel System Components (typical)

2.9 Fuel Cooling System

The fuel cooler side of the radiator maintains fuel temperature to meet the maximum allowable fuel inlet temperature (shown on the fire pump drive engine data sheet). Performance of the fuel cooling system is critical to engine durability, performance, and emissions compliance.

2.10 Air Intake System

The air intake system supplies combustion air to the fire pump drive engine cylinders. The air filter prevents particulate matter from entering the air intake. As shown in Figure 2-18, combustion air drawn into

the system by the turbocharger is directed through the CAC side of the radiator for cooling before entering the intake manifold.

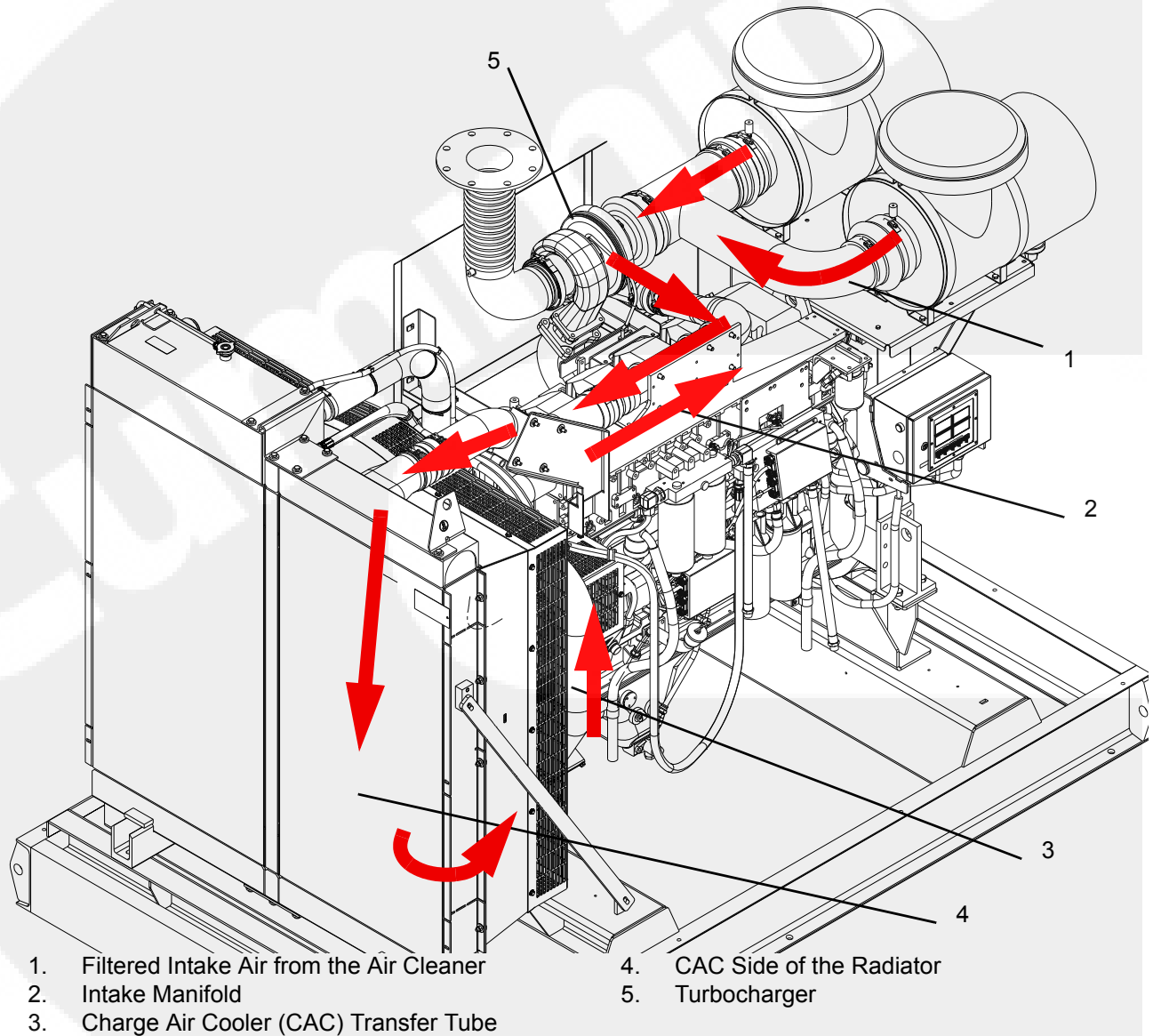

Figure 2-18 Engine Air Intake and Charge Air Cooling Flow Diagram (typical)

Description

2.11 Cooling Water System

The fire pump cooling system is configured with an engine radiator system. A fuel cooler (where supplied) and a water-to-air closed loop radiator system helps the engine meet emission levels while improving engine performance and efficiency. See the model specific Engine Data Sheet for specific operating temperatures and pressures.

As shown in [Figure 2-19](#), water enters the radiator cooling circuit through the inlet to the radiator. The coolant then moves through the cooling tubes in the radiator and into the engine water pump inlet. The coolant circulates through the engine jacket water circuit and out of the engine, then back to the radiator.

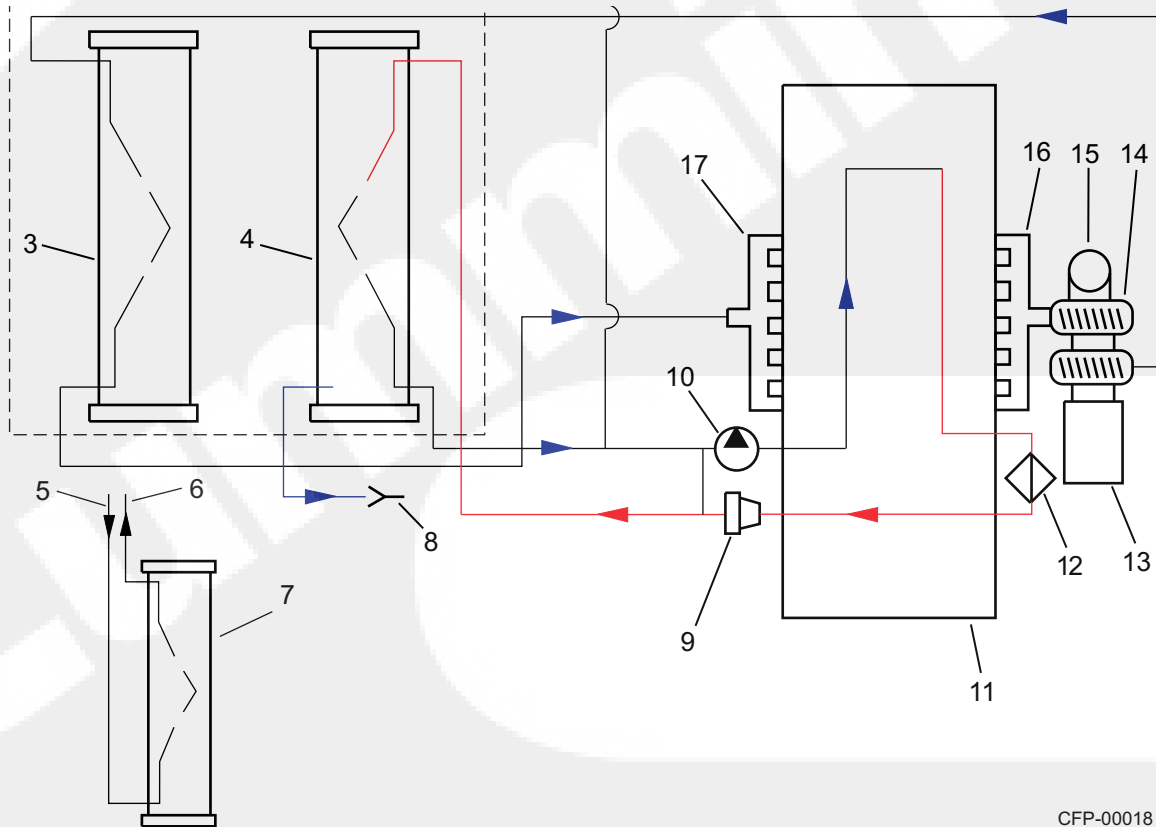

- | | |
|--|-----------------------------|
| 1. Coolant Pressure/Fill Cap | 9. Engine Thermostat |
| 2. Radiator Expansion Tank | 10. Coolant Pump |
| 3. Charge Air Cooler (CAC) Side of Radiator | 11. Engine Block |
| 4. JW Heat Exchanger Side of Radiator | 12. Coolant Filter |
| 5. Fuel Inlet | 13. Air Filter |
| 6. Fuel Outlet | 14. Turbocharger |
| 7. Fuel Cooler on Charge Air Cooler Side of Radiator | 15. Exhaust Flex Connection |
| 8. Drain Line | 16. Exhaust Manifold |
| | 17. Intake Manifold |

Figure 2-19 Engine Cooling System Flow Diagram (typical)

Air that enters the air cleaner gets transferred to the turbocharger and then is routed to the charge air cooler side of the radiator where it is cooled.

The fuel comes from the fuel tank and a portion of the fuel is transferred to the engine fuel pump, where it is moved through a fuel manifold, to be consumed in

engine combustion. The remainder is used to cool the fuel injectors.

The fuel used to cool the injectors is then plumbed to a fuel cooler on the side of the radiator which cools the fuel before it is returned to the fuel tank (where supplied).

IMPORTANT: *Monitor the oil pressure and coolant temperature gauges frequently. Refer to Lubricating Oil System Specifications or Cooling System Specifications in the Engine Data Sheets for recommended operating pressures and temperatures. Shut off the engine if any pressure or temperature does not meet the specifications.*

Maximum engine coolant temperature should not exceed the temperature listed on the Engine Data Sheet. The coolant expansion pressure/fill cap must meet the minimum pressure of 10 kPa (15 psi).

The engine coolant system contains a mixture of at least 50% antifreeze and 50% water. The coolant level should be maintained so it is visible in the coolant level sight gauge.



CAUTION

Continuous operation with low coolant temperature (below 70° C [158° F]) or high coolant temperature (above 107° C [225° F]) can damage the engine. Verify raw water pressure and flow.



Description

2.12 Engine Oil System

Figure 2-20 illustrates how the engine oil system lubricates moving internal engine parts (pistons, connecting rods, valves, cam shafts, shafts, and bearings). The oil pump circulates oil from the oil pan, through the oil filter, and into engine areas where friction may develop. Refer to the Cummins engine Operation and Maintenance Manual for additional information.

NOTE: Typically engine oil has been added during manufacture and testing procedures; however, shipping restrictions can affect whether the oil is maintained in the engine or drained for shipping. Check the oil level at the dipstick. Add oil as necessary to bring the oil level to the H (high) mark on the dipstick.

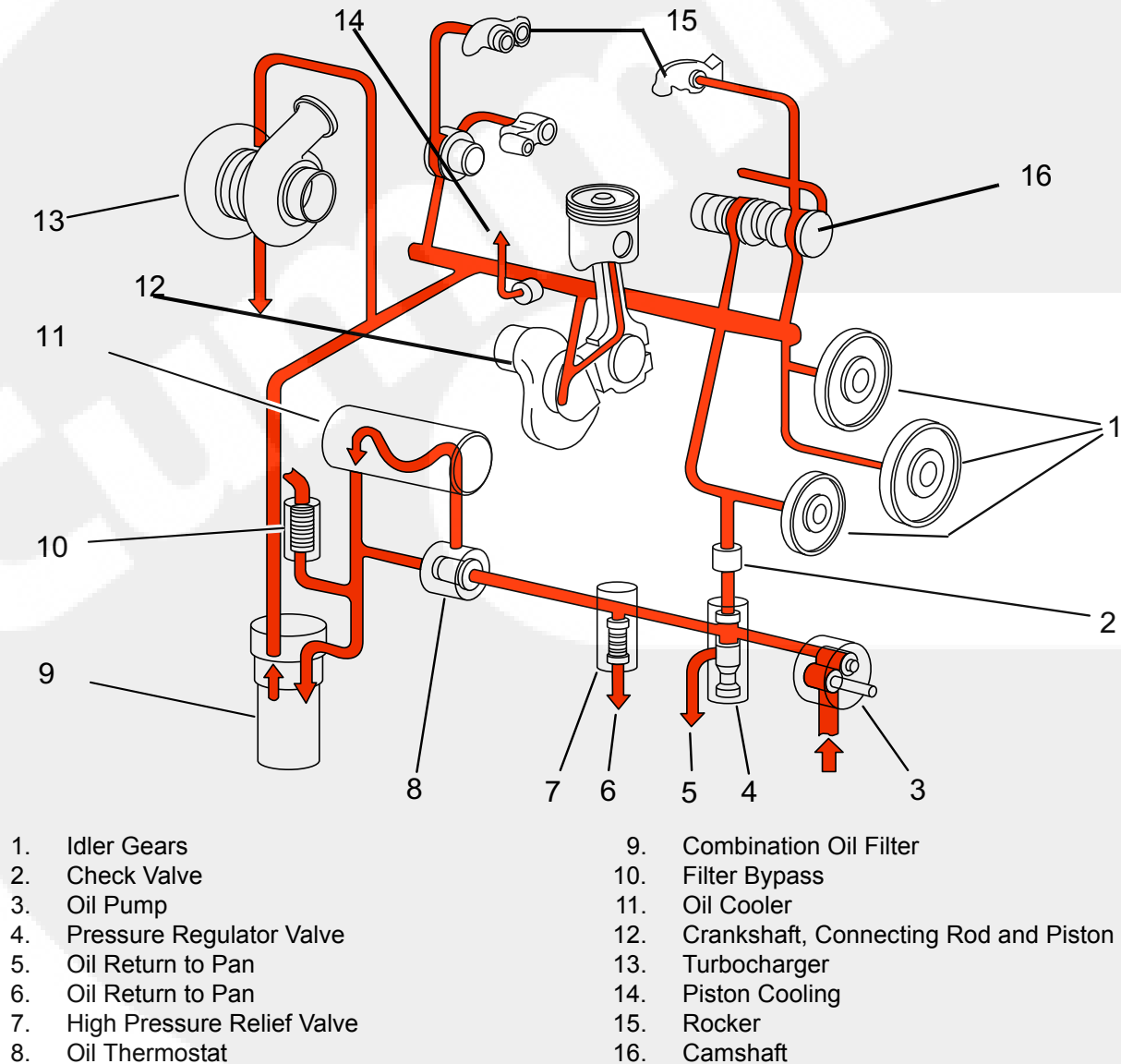
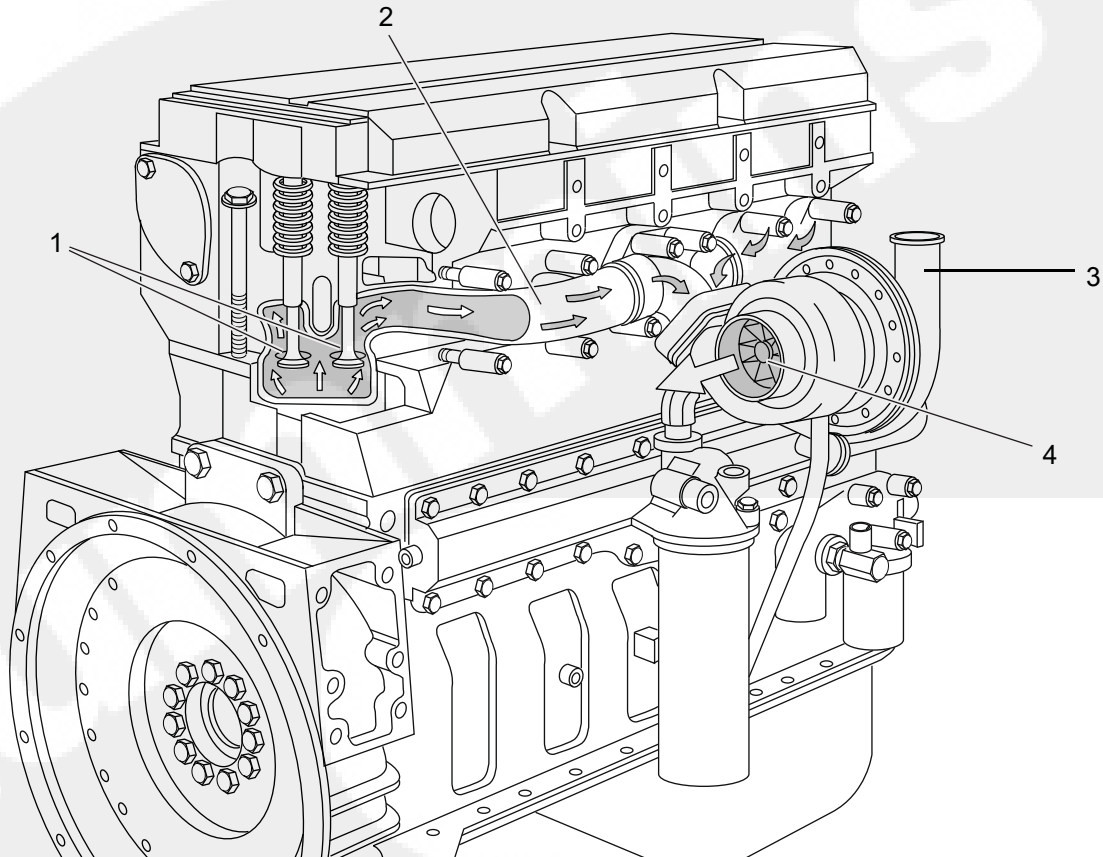

Figure 2-20 Engine Lubricating Oil System Flow Diagram (Typical)

2.13 Exhaust System

Figure 2-21 shows how the exhaust system removes engine exhaust from the cylinders after the combustion process and Figure 2-22 shows the turbocharger

exhaust flow for a wastegated engine. The exhaust discharges from the exhaust manifold, passes through (drives) the turbocharger, and exits through the exhaust connection.



- | | |
|----------------------------|--|
| 1. Exhaust Valve Ports | 3. Combustion Air to Charge Air Cooler |
| 2. Engine Exhaust Manifold | 4. Turbocharger Turbine |

Figure 2-21 Exhaust System Flow Diagram (typical)



Description

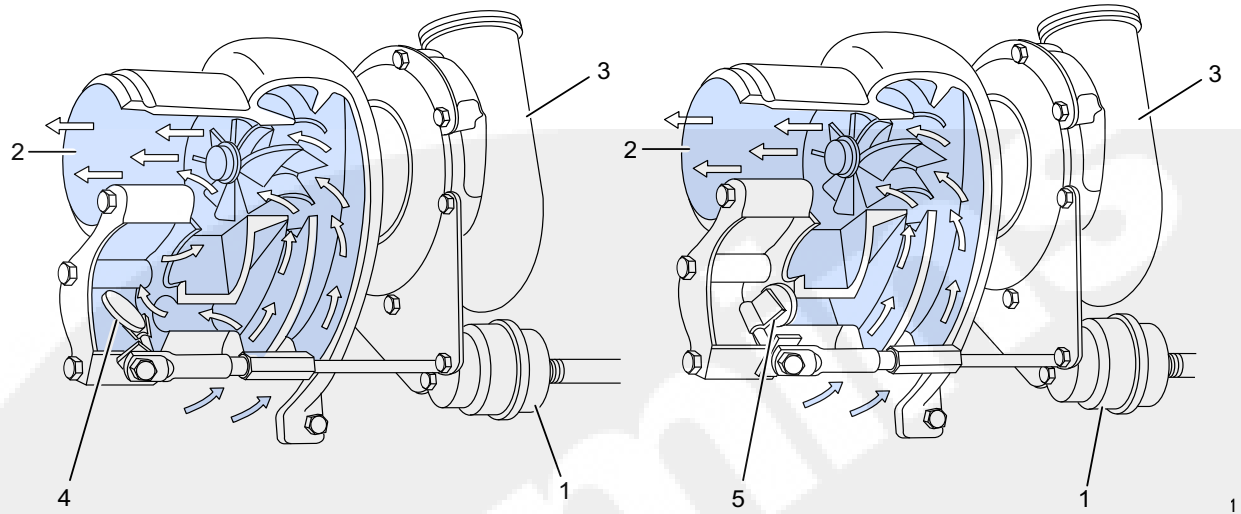

1. Wastegate Actuator Cylinder
2. Exhaust Flow to Flex Pipe
3. Combustion Air to Charge Air Cooler

4. Wastegate OPEN
5. Wastegate CLOSED

Figure 2-22 Turbocharger Exhaust Flow Diagram (typical)

Section 3 - Installation

3.1 Introduction

This section provides instructions for the initial installation, adjustment, and testing of the Cummins fire pump drive engine. Appropriate portions of this section should be used when returning the engine to operation after overhaul or major maintenance.

3.2 Receiving and Handling

Cummins fire pump drive engines are pre-assembled and tested before shipment. Parts not shipped attached to the engine are sometimes shipped individually. The equipment was thoroughly inspected and prepared for shipping before it was turned over to the carrier. Upon receipt of the fire pump drive engine from the shipper:

1. Inspect the equipment for damage that may have occurred in shipping; and
2. Check each item carefully against the shipping manifest or bill of lading.

3.3 Site Preparation

The site should be clean and relatively level. Clear the proposed equipment area of overhanging obstructions and obstacles protruding from the floor.

CAUTION

Avoid installation in a dusty or dirty environment. Provide adequate physical protection from other physical damage as may be present in the specific location.

3.4 Drive Shaft Installation

Drive shaft installation should be done by trained technicians familiar with local, state, and federal codes and regulations.

Refer to National Fire Protection Association (NFPA) 20 for installation and applicable local code requirements and NFPA 25 for inspection, testing, and maintenance requirements.

Follow these steps to install the drive shaft:

CAUTION

Ensure that the lifting device is capable of safely lifting the weight of the engine or the combined weight of the assembled pump base, drive line, and pump. Do not use the engine lifting points for assembly!

1. Ensure that the engine and pump are correctly aligned.
 - a. Ensure that the engine position is centered on the frame side to side within $\pm .76$ mm (.03 in) by measuring outside of the frame side to the engine support leg mounting pad. (Compare the two front engine supports and two back engine supports.)
 - b. As shown in [Figure 3-1](#), align the engine center line to the pump center line within $\pm .76$ mm (.03 in).
 - c. Ensure that the pump center line to the engine crankshaft center line (in vertical plane) is $2^\circ \pm 1^\circ$.
 - d. Ensure that the drive shaft mounting flanges are parallel.
2. As illustrated in [Figure 3-2](#), lubricate the grease fittings on the drive shaft universal joint.
3. Check that the fire pump drive engine is properly installed per the pump manufacturer's specifications.

Installation

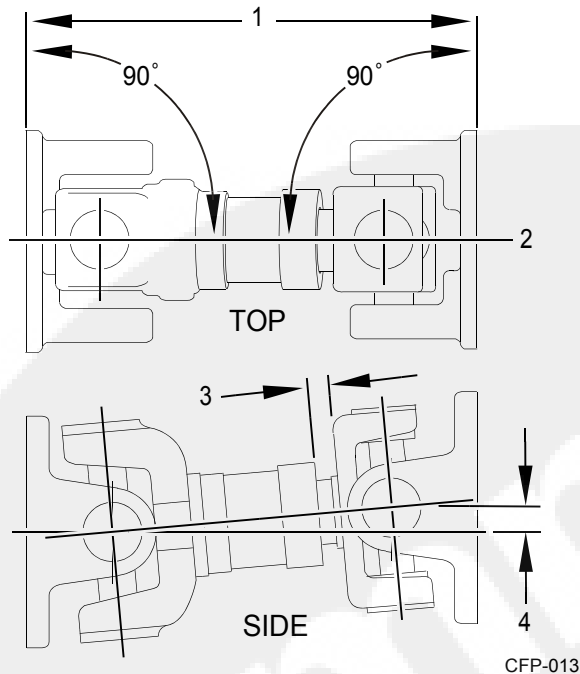

1. Planes must be parallel
2. Align both mounting center lines to $\pm .76$ mm (.03 in)
3. Distance to equal half of total travel
4. $2^\circ \pm 1^\circ$

Figure 3-1 Drive Shaft Alignment

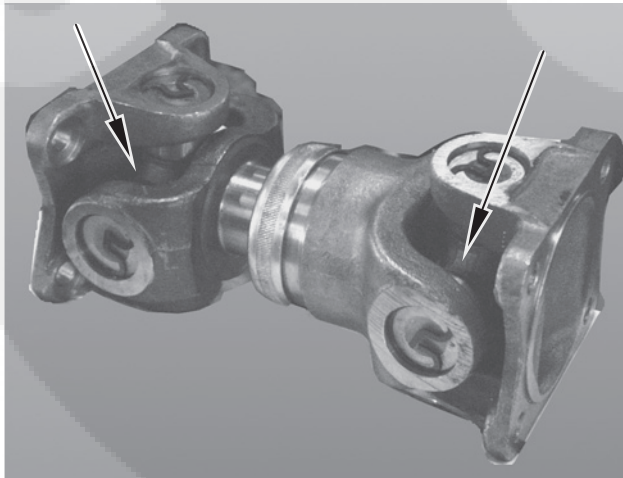

Figure 3-2 Drive Shaft Universal Joint Grease Fittings

NOTE: Cummins recommends using a good quality semi-synthetic, molybdenum-fortified National Lubricating Grease Institute (NLGI) #2 lithium complex grease.

NOTE: Some lubrication loss may occur during transport and storage. It is recommended that the drive shaft be re-lubricated upon installation.

3.5 Fuel Supply Installation

NOTE: It is the responsibility of the customer to provide and install a properly-rated fuel tank per NFPA 20 guidelines.

To properly install a fuel supply, follow these instructions:

1. Install an elevated no. 2 diesel fuel tank or other fuel supply arrangement which is compatible with American Society of Testing and Materials (ASTM) no. 2 diesel fuel specifications.

NOTE: The fuel supply line at the fuel tank must be higher than the fuel intake port on the engine fuel filter. Ensure that the fuel system is installed in a safe and effective manner.

2. Size the fuel tank for the maximum expected full-load engine operation period with the initial fuel level at the minimum level for refueling.
3. Install a fuel return line and route this line to the bottom of the fuel tank in order to minimize the return head.
4. Install a fuel supply line to the fire pump drive engine.

NOTE: For fuel line specifications, refer to the [Engine Data Sheet](#).

NOTE: DO NOT use copper or galvanized pipe for the fuel return or supply lines.

The fire pump drive engine fuel system has been primed during manufacturing and test procedures. The engine is equipped with an engine driven (gear) fuel pump.

An optional fuel pre-filter and a fuel filter/water separator is integrated into the fuel delivery system of the fire pump drive engine. To ensure that the filter/separator is free of water, open the fuel filter/water separator drain at the bottom of the filter and drain the fuel into a container until no water is present. Dispose of the contaminated fuel in accordance with local environmental regulations.

CAUTION

Due to the precise tolerances of diesel injection systems, it is extremely important that the fuel be kept clean and free of dirt or water. Dirt or water in the system can cause severe damage to both the fuel pump and the fuel injectors.

WARNING

Do not mix gasoline, alcohol, gasohol, ethanol, or methanol with diesel fuel. This mixture will cause severe engine damage or explosion.

CAUTION

Use ONLY no. 2 diesel (ASTM no. 2D) fuel. Any fuel other than no. 2 diesel fuel may affect emission levels. Any adjustment to compensate for reduced performance with a fuel system using alternate fuel is not warrantable. CumminsK Papsi

IMPORTANT: Monitor the oil pressure and coolant temperature gauges frequently. Refer to Lubricating Oil System Specifications or Cooling System Specifications in the [Engine Data Sheet](#) for recommended operating pressures and temperatures. Shut off the engine if any pressure or temperature does not meet the specifications.

NOTE: Maximum engine coolant temperature should not exceed the temperature listed on the [Engine Data Sheet](#). The coolant expansion pressure/fill cap must meet the minimum pressure of 10 kPa (15 psi).

The engine coolant system contains a mixture of at least 50% antifreeze and 50% water. The coolant level should be maintained so it is visible in the coolant level sight gauge.

3.6 Battery Installation

The minimum recommended Society of Automotive Engineers (SAE) reserve capacity (RC) and SAE cold cranking ampere (CCA) values for a particular engine can be found on the [Engine Data Sheet](#). RC and CCA definitions can be found in SAE Standard J537. Refer to NFPA 20 and FM 1333 standards for additional battery installation information.

WARNING

Battery electrolyte (sulfuric acid) is highly caustic and can burn clothing and skin. Wear impervious neoprene gloves and safety goggles, or a full face

shield, when working with the batteries.

IMPORTANT: Batteries must meet the requirement listed in the electrical system specifications. Batteries may be supplied by Cummins as an option, or may be supplied by the customer.

To properly install the batteries:

1. As shown in [Figure 3-3](#) or [Figure 3-4](#), install the Battery Cable Kit or equivalent customer-supplied wiring. Install battery sets in a well-ventilated or otherwise protected location.

WARNING

Batteries can emit explosive gases during charging. Always ventilate the compartment before servicing the batteries. To avoid arcing, remove the negative (-) battery cable first and attach the negative (-) battery cable last.

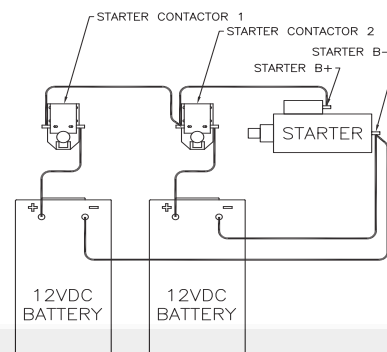

Figure 3-3 Series Battery Connection 12 VDC

2. Provide adequate room for servicing or replacing the batteries. Provide protection from extremes of temperature and weather.
3. Locate the batteries near the engine or increase the size of the conductors as required by applicable codes. Ensure that the batteries are configured properly for 12 - or 24 - VDC standard operations.
4. Check the battery cables and connections.

NOTE: Coat the terminals with petroleum jelly to prevent corrosion. Install the cables and tighten the battery connections.

Installation

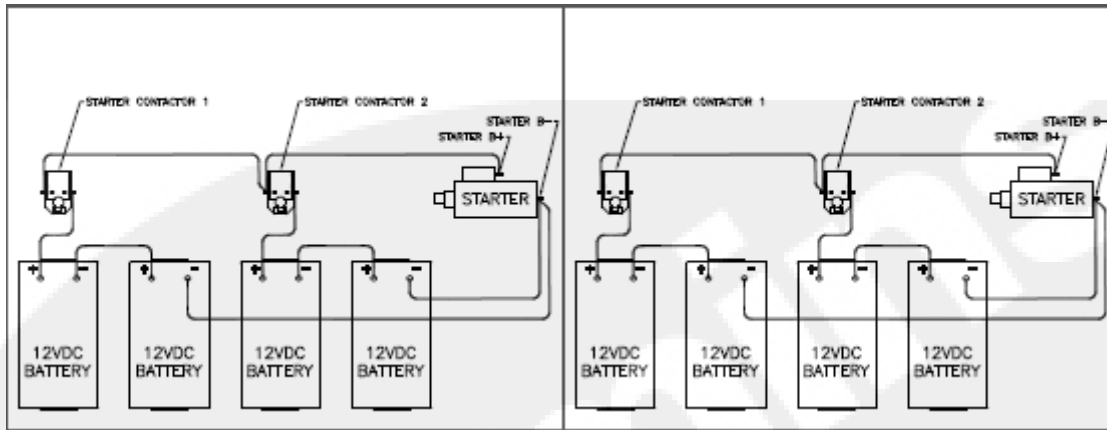

Figure 3-4 Series Battery Connection 24 VDC

3.7 Signal and Control Installation

The fire pump controller wires must be connected to the terminal blocks (TBs) on the FPDP Interface Terminal Strip and on the Battery Charger Interface. To complete the signal and control installation:

1. Ensure that the fire pump controller is properly installed and configured per the manufacturer's instructions.
2. Complete the fire pump controller wiring (customer-supplied) per the manufacturer's instructions.
3. Ensure electrical continuity and adequate insulation resistance for the installed wiring. Refer to the Operation - Engine Setup Screen section to conduct a Terminal Block Test from the FPDP.

3.7.1 FPDP Interface Terminal Strip

As shown in Figure 3-5, the TBs between the fire pump controller and the fire pump driver are standard UL and FM controller terminals and follow a direct one-to-one correspondence (some TBs are optional):

- a. TB-1 [Run Solenoid Circuit]: This B+ signal is necessary for fire pump operations while in the FPDP is in AUTO mode. The Electronic Control Module (ECM) keyswitch/Fuel Shut-off (FSO) and raw water solenoid are activated when voltage is present at TB-1. When TB-1 is removed while the engine is running, the FPDP will command electronic engines to idle for up to three minutes.
- b. TB-2 [Crank Termination Switch]: This B+ signal is provided by the FPDP to inform the pump controller that the engine is running. Crank Termination indicates that the engine has started and that the crank command from the fire pump controller should stop immediately.
- c. TB-3 [Overspeed Switch]: This B+ signal is provided by the FPDP when the engine speed has exceeded 115% of the rated engine speed. When overspeed occurs, the ECM keyswitch or FSO outputs and the raw water cooling loop solenoid are immediately deactivated in an attempt to stop the fire pump drive engine. The FPDP will not allow the engine to be restarted until after the overspeed alarm has been reset.
- d. TB-4 [Low Lubricant Pressure Switch]: A ground path is provided by the FPDP when the oil pressure has dropped below the 16 psi (110 kPa) setpoint when the engine is running. A ground path is also provided to indicate low oil pressure when the engine is NOT running.
- e. TB-5 [High Engine Temperature Signal]: A ground path is present when the engine is running and the coolant temperature is at or above 212 °F (100 °C).
- f. TB-9 [Main Battery Contactor One Coil or Battery Relay One Coil]: This B+ signal is driven from the fire pump controller to contactor A when desiring to crank the engine from

Battery A. Current in this circuit shall not exceed 10A continuous.

- g. **TB-10 [Main Battery Contactor Two Coil or Battery Relay Two Coil]:** This B+ signal is driven from the fire pump controller to contactor B when desiring to crank the engine from Battery B. Current in this circuit shall not exceed 10A continuous.
- h. **TB-301 [ECM Switch]:** A ground path is provided by the FPDP when the engine is operating on ECM B.
- i. **TB-302 [Fuel Injection Malfunction (FIM)]:** A ground path is provided by the FPDP when either of the ECMs triggers a fault code which can affect the performance of the Fuel Injection System. See the Troubleshooting section for possible fault causes and solutions.
- j. **TB-303 [ECM Warning]:** A ground path is provided by the FPDP when a single ECM has been diagnosed as failed.
- k. **TB-304 [ECM Failure]:** A ground path is provided by the FPDP when both ECMs have been diagnosed as failed.
- l. **TB-305 [Custom Output 1]:** A ground path is provided by the FPDP when the custom alarm is configured and activated.

NOTE: *If an Air Shutoff Valve is purchased, TB-305 is reserved for valve position feedback.*

- m. **Type K Thermocouple Input - optional:** The screws to the Type K thermal couple input may be loosened for installation of an exhaust temperature.
- n. **TB-306 [Custom Output 2]:** A ground path is provided by the FPDP when the custom alarm is configured and activated.
- o. **TB-307 [Custom Output 3]:** A ground path is provided by the FPDP when the custom alarm is configured and activated.

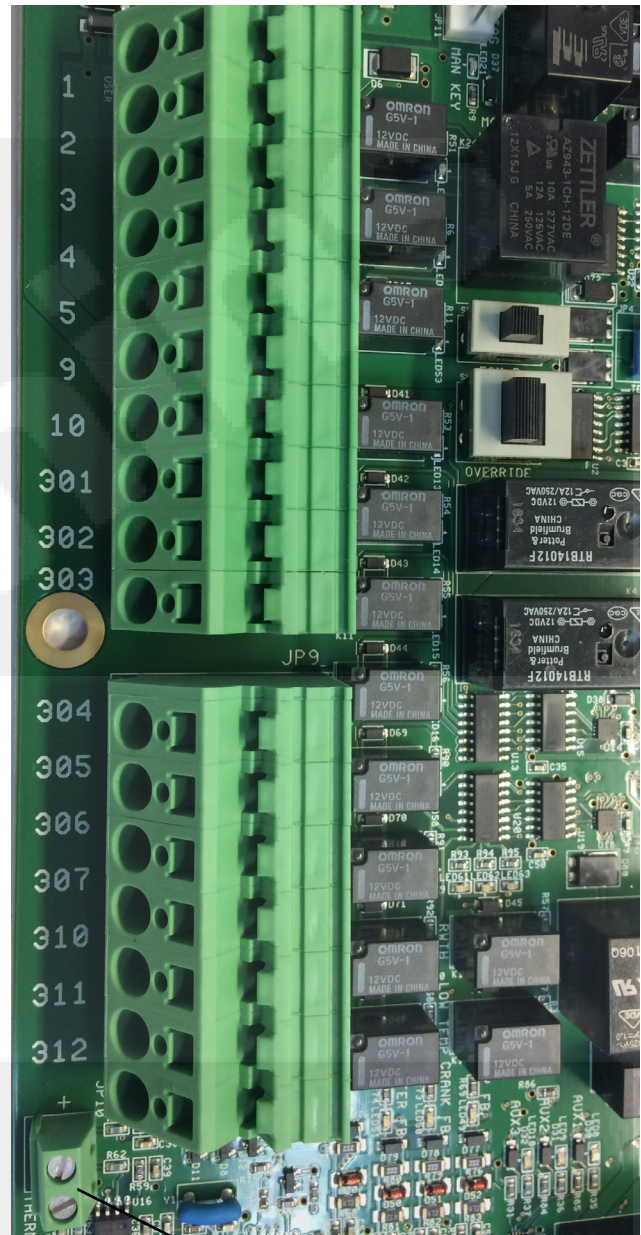

Thermocouple Input

Figure 3-5 FPDP Interface Terminal Strip

- p. **TB-310 [Raw Water High Inlet Temperature] - not applicable on radiator-cooled models -** A ground path is provided by the FPDP when high raw water temperature is sensed.
- q. **TB-311 [Clogged Raw Water Coolant Loop Strainer] - not applicable on radiator-cooled**

Installation

models - A ground path is provided by the FPDP when the raw water supply restriction is sensed.

- r. TB-312 [**Low Engine Temperature Signal**]: A ground path is provided by the FPDP when the engine coolant falls below 100 °F (37.8 °C).

3.7.2 Battery Charger Interface

As shown in Figure 3-6, the Battery Charger Interface provides power to the fire pump controller, as well as provides charging current to the fire pump drive engine batteries. The Battery Charger Interface includes:

- a. TB-6 [**Battery A Positive**]: The fire pump controller senses Battery A charge state and charges Battery A through TB-6.
- b. TB-8 [**Battery B Positive**]: The fire pump controller senses Battery B charge state and charges Battery B through TB-8.
- c. TB-11 [**Battery A and Battery B Negative**]: The fire pump controller uses TB-11 as a ground reference for incoming power, as well as to charge the fire pump drive engine batteries.

NOTE: *This is not intended to create a fully isolated battery negative or ground system. Current in each terminal block shall not exceed 30 amperes continuous.*

To complete the battery signal connections:

1. Provide the initial charge on the redundant batteries per the battery charger's instructions.
2. Check that both voltmeters on the FPDP indicate the approximate battery voltage.

NOTE: *Both sets of batteries can be used for starting the engine in the event that one set is low.*

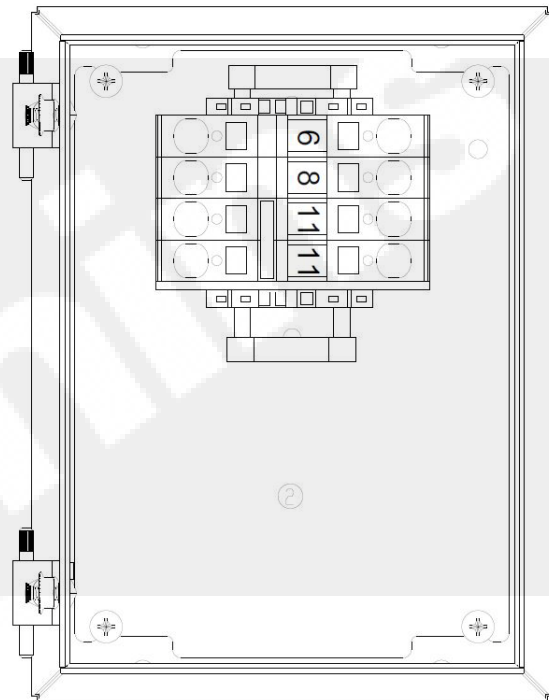

Figure 3-6 Battery Charger Interface

3.8 Coolant System Preparation

The fire pump drive engine cooling and lubrication system was initially filled during manufacture and testing. To properly prepare the coolant system:

CAUTION

Ensure that all coolant systems have been filled to the proper level before operation by checking the coolant level sight gauge on the radiator .

1. Inspect the engine coolant hoses and hose clamps and ensure that all coolant hoses and clamps are properly installed and water tight.
2. Ensure that the engine coolant heater maintains an engine coolant temperature of 49 °C (120 °F) or above.
3. Ensure that coolant is present in the engine coolant heater before plugging the heater element into a dedicated circuit. Add coolant, if necessary.

4. Inspect the radiator core weekly for external damage and contamination. Blow out all insects, dust, dirt, and debris such as leaves, bits of paper, etc. that may be on the front of the radiator core or lodged between the radiator core and the cooling fins and tubes.

NOTE: Contamination of the radiator core will affect the ability of the cooling system to transfer heat and properly cool the engine and intake manifold.

5. Add coolant, if necessary:

NOTE: Supplemental engine coolant should be a mixture of 50% ethylene glycol antifreeze and 50% water to avoid engine damage. For additional information, refer to the antifreeze information found in the Maintenance section.

- a. If the engine is equipped with a sight level gauge, ensure that the engine coolant level is visible at the center of the sight level gauge. Add coolant as required. **DO NOT OVER-FILL!**
- b. If the engine is not equipped with a sight level gauge, fill the cooling system with coolant to the bottom of the fill neck. Do not fill above the bottom of the fill neck. **NOTE:** Some radiators have two fill necks, both of which must be filled when the cooling system is drained.

6. Re-install the pressure/fill cap.

3.9 Radiator Cooling System Inspection

The radiator cooling system reduces the temperature of the compressed combustion air from the turbocharger before entering the air intake manifold.

Coolant circulated through the radiator system cools the fuel and the engine. The coolant is forced through the cooling system to the various components and is considered a closed loop system. It is essential to perform an inspection of the radiator cooling system according to these steps:

1. Inspect the radiator piping and hoses for loose/missing hose clamps, hose punctures, leaking manifold seals, or corrosion. Torque the hose clamps to the recommended torque value. Refer to the [Torque Tables](#).

2. Conduct a weekly visual inspection of the cooling fan. Check for cracks, loose rivets, and bent or loose fan blades.
3. Check the fan to make sure it is securely mounted. Tighten the capscrews to the recommended fastener torque. Replace any fan that is damaged.

WARNING

Personal injury can result from a fan blade failure. Never pull or pry on the fan. This can damage the fan blade(s) and cause fan failure.

WARNING

Do not remove the pressure/fill cap from a hot engine. Wait until the coolant temperature is below 50 °C (122 °F) before removing the pressure/fill cap. Heated coolant spray or steam can cause personal injury.

3.10 Lubricating Oil System Preparation

The fire pump drive engine and turbocharger were initially lubricated during manufacture and testing. To prepare the lubricating oil system for operation:

1. Check the oil level using the dip stick before operating the fire pump drive engine.
2. Fill the oil fill port to the “H” mark on the dipstick with lubricating oil.

NOTE: Do not use special “break-in” lubricating oils for new or rebuilt Cummins engines. Use the same type of oil during the “break-in” as used during normal operation.

CAUTION

Some regulatory and shipping restrictions may require that all lubricants, fuels, and coolants be drained for transport. Ensure that all cooling and lubrication systems have been filled to the proper level before operation.

NOTE: Using multi-viscosity lubricating oil can improve oil consumption control and improve engine cranking in cold temperatures while maintaining lubrication at high operating temperatures. Cummins recommends Premium Blue® 15W-40 oil for most climates.

Installation

CAUTION

Ensure that all cooling and lubrication systems have been filled to the proper level before operation.

3.11 Variable Speed Pressure Limiting Control (VSPLC) Preparation

NOTE: VSPLC capability is on electronic engines, only. This section is not applicable to mechanical engines.

As shown in [Figure 3-7](#), to prepare the fire pump drive engine for VSPLC capability, connect a 1/2 inch (12.7 mm) inside diameter pressure sensing line to the transducer located under the FPDP and the other end to between the pump discharge flange and the discharge check valve.

IMPORTANT: Cummins recommends that provisions be made within the VSPLC connection line to account for any engine vibration and movement.

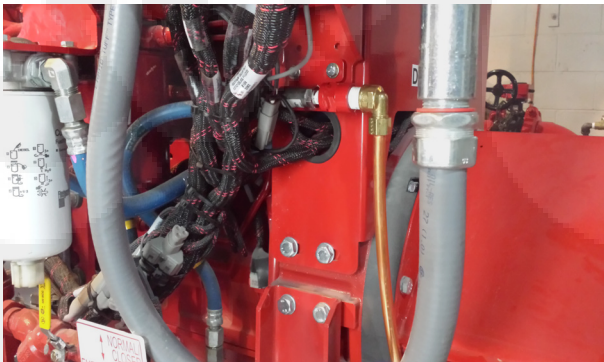

Figure 3-7 VSPLC Pressure Sensing Connection

3.12 Pre-Start Inspections

Prior to starting the fire pump drive engine for the first time, perform a visual inspection:

1. Check that there is no apparent damage and that all components are installed.
2. Check that the drive belt is properly installed.
3. Check that all hoses and tubes are properly installed.

4. Check that all electrical connections are properly installed.
5. Check that the fire pump drive engine is properly installed per the pump manufacturer's instructions, is correctly aligned, and is free to rotate.
6. Lubricate the grease fittings on the axillary drive shaft.

NOTE: Use the same type of oil as used in normal operation. Cummins recommends Premium Blue[®] 15W-40 oil for most climates.

WARNING

Before operating the equipment, complete all safety checks, remove all tools and foreign objects from the equipment, and ensure that all guards are in place and securely fastened. Alert area personnel that the equipment will be starting. Unintentional equipment start-up or contact with exposed or moving components can cause personal injury or equipment damage.

3.13 Engine Monitoring

When the engine starts, it is important to monitor the displays:

1. Immediately check that water flow is established through the radiator. The water flow should be established immediately, but some delay may occur before the flow exits the radiator drain connection.
2. *Ensure that cooling water is flowing* Ensure that the engine operating temperature stabilizes between applicable ranges as identified in the [Engine Data Sheet](#).
3. Operate the engine for eight to ten minutes.
4. Inspect the engine for leaks, unusual noises, or other indications of incorrect operation.
5. While running the engine, look for the following signals during operation and field testing:
 - Low engine lubricant pressure



CAUTION

If the oil pressure is not displayed on the gauge or if the low oil pressure message is displayed within fifteen seconds, STOP THE ENGINE IMMEDIATELY! Continued operation without proper lubrication will cause engine damage.

- High engine coolant temperature
 - Low engine temperature
 - High raw water temperature
6. Shut off the engine by pressing and holding the overspeed **RESET/STOP** switch.
 7. Shortly after the engine stops, check that the water flow stops automatically.
 8. Correct any problems found during the inspection before proceeding.

9. Check the engine lubricating oil level at the dip stick. Add oil, if necessary.
10. Check the coolant level sight gauge on the radiator. Add coolant, if necessary.
11. Perform engine speed control and safety system tests per the instructions in [Section 4 - Operation](#).

3.14 Field Acceptance Testing

The required installation tests are outlined in the NFPA 20 Standards and shall be performed to validate automatic and manual operational requirements for field acceptance testing.

1. Place the FPDP in MANUAL mode.
2. Start the fire pump drive engine and run a fixed speed test.

NOTE: *The maximum engine speed should only be altered by a Cummins technician.*



This page is intentionally left blank.



Section 4 - Operation

4.1 Introduction

This section outlines general operating information for starting and stopping the fire pump drive engine, as well as instructions for navigating the menu screens of the Fire Pump Digital Panel (FPDP). This manual is provided for your equipment and should be considered a part of that equipment. All personnel responsible for the operation and maintenance of the equipment should read and thoroughly understand this manual.

WARNING

Before preparing the equipment for normal service, complete all safety checks, remove all tools and foreign objects from the equipment, ensure all guards are in place and securely fastened, and alert area personnel that the equipment will be starting.

4.2 Starting and Stopping Procedures

By default, the fire pump drive engine will turn on automatically when low system water pressure is sensed by the pump controller. The engine will continue to operate as long as TB-1 is active. When the TB-1 signal is terminated by the fire pump controller, the engine will stop or enter a cool down procedure by lowering the engine speed.

For testing purposes, the fire pump drive engine can be turned on and off locally using the buttons on the FPDP (see the FPDP Description section). If the engine fails to start automatically in the event of a fire emergency, follow the Emergency Starting/Stopping Procedure outlined in Section 4.2.2.

4.2.1 Local Starting/Stopping Procedure

To start the engine locally from the FPDP:

1. Press the AUTO/MAN selector switch on the FPDP to place the engine in MANUAL mode.
2. Press the CRANK BATT A and/or CRANK BATT B button to crank the engine.

The engine may be stopped locally by pressing the RESET/STOP switch on the FPDP or by holding down the red Engine STOP button on the left side of the FPDP.

NOTE: Upon release of the Engine STOP Button, the fire pump drive engine will attempt to restart. If there is still a "pump on demand" signal present from the fire pump controller. The engine must also be stopped at the fire pump controller.

4.2.2 Emergency Starting/Stopping Procedure

The engine will start automatically in the event of a fire emergency. However, if it fails to start automatically, the engine can be started locally. The following procedure outlines an emergency manual mode electrical start:

1. Press the AUTO/MAN selector switch on the FPDP to place the engine in MANUAL mode.
2. As shown in [Figure 4-1](#), open the FPDP panel door and slide the key switch override to the "RIGHT" position. Verify that LED 49 - KEY FB (key feedback) switch is lit.



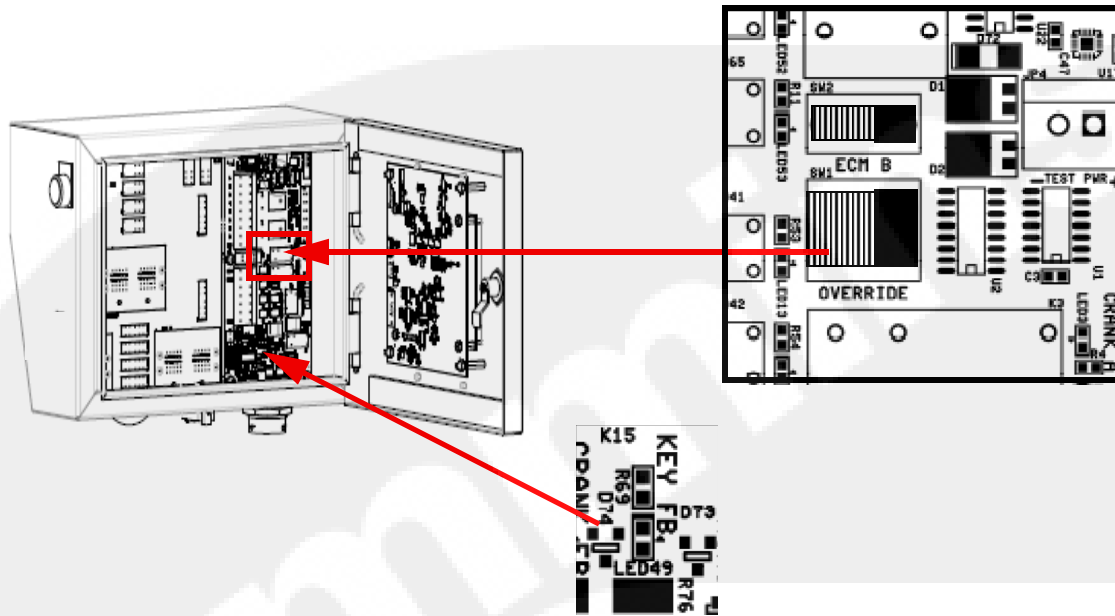

Figure 4-1 FPDP Override Switch

! CAUTION

To prevent damage to the starter, do not engage the starting motor more than fifteen seconds. Wait fifteen seconds between each attempt to start, up to six attempts.

3. As shown in [Figure 4-2](#), press downward on either the Battery A or Battery B contactor lever to start the engine. If crank contactor lever A does not engage the starter, repeat using crank contactor lever B. If the battery charge is low, press downward on both battery contactor levers at the same time. Release the contactor lever immediately after the engine starts.

IMPORTANT: *If the engine does not start after three attempts, check the fuel supply system. Absence of blue or white exhaust smoke during cranking indicates that no fuel is being delivered.*

4. Check that the engine starts and operates at the rated speed.

IMPORTANT: *Engine oil pressure must be indicated on the gauge within fifteen seconds after starting.*

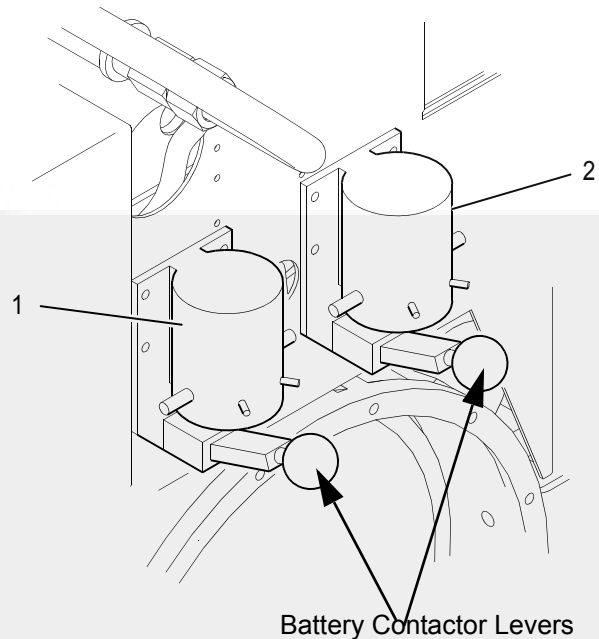

1. Battery A Starter Contactor
2. Battery B Starter Contactor

Figure 4-2 Manual Starter Contactors

The engine may be stopped locally by pressing the RESET/STOP button on the FPDP or by holding down the red ENGINE STOP button on the left side of the FPDP.

IMPORTANT: Upon release of the Engine STOP Button, the fire pump drive engine will attempt to restart, if there is still a “pump on demand” signal present from the FPDP. The engine must also be stopped at the fire pump controller.

4.3 Fire Pump Digital Panel (FPDP) Screens and Adjustments in Automatic Mode

The FPDP consists of an LCD touchpad that displays the fire pump drive engine tachometer, coolant temperature, oil pressure, Battery A voltage, Battery B voltage and hour meter, as well as includes two or three soft keys:

- SCREEN Soft Key
- MENU Soft Key
- IDLE Soft Key (electronic engines in MAN mode, only)

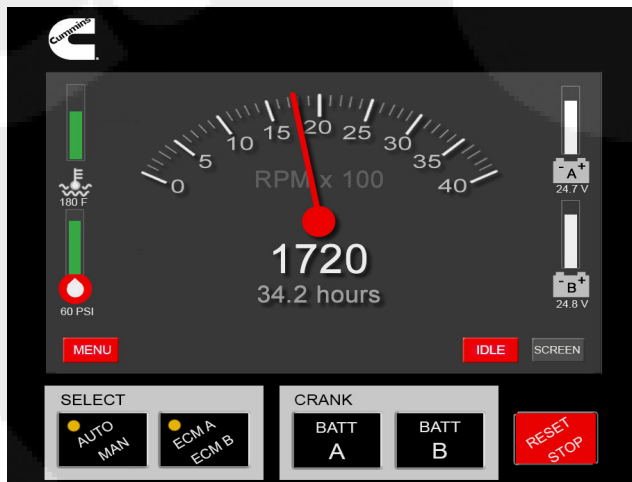

Figure 4-3 FPDP User Interface Screen (Electronic Engine)

NOTE: Electronic engines display tachometer, engine temperature and oil pressure values from J1939. Mechanical engines display parameters via sensors added by Cummins.

NOTE: When the key switch is not on, the coolant temperature defaults to “0 °F” (or “0 °C”) and the oil pressure defaults to “0 PSI” (or “0 kPa”).

The FPDP LCD will go into SLEEP MODE after fifteen minutes of inactivity by the user. The FPDP LCD will resume normal display features when the user presses a hard button or touches the LCD screen.

4.3.1 The SCREEN Soft Key

The SCREEN Soft Key, on the bottom right of the LCD, deactivates and activates an overlay box which lies atop the tachometer signal (the engine speed is still digitally displayed). The overlay is used to:

- Automatically - Warn the operator of ECM and/or DPEM faults, when applicable (see Section 4.3.2.6 FAULT CODES Screen); and/or
- Operator-selected - Display additional analog values not required by NFPA 20.

The overlay background color will display in gray, unless there is an active fault present. Fault overlays will display in the color of the most severe fault. To deactivate the Fault overlay, press the SCREEN Soft Key to make the overlay disappear from the LCD.

As shown below, the Analog Values overlay background color displays in gray.

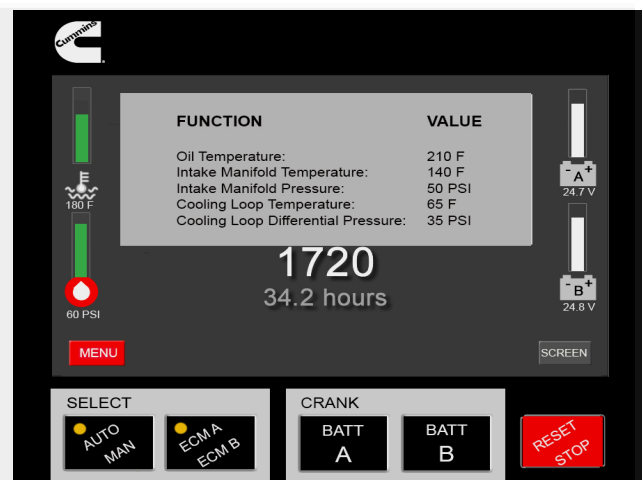

Figure 4-4 Analog Values Overlay (Electronic Engine)

Additional values that may be displayed include:

Operation

- Exhaust temperature (when a pyrometer is installed and terminated to the Power Board).
- Cooling loop raw water temperature and strainer status on FM-approved and UL-listed fire pump drivers. The Analog Values Overlay can assist in troubleshooting the cooling loop by identifying issues with the pressure sensors.
- J1939 parameters.

NOTE: The Oil Temperature value (from J1939) will only be shown on CFP11E and CFP15E.

NOTE: The Intake Manifold Pressure (from J1939) will be showing 0 PSI at no load.

NOTE: A thermocouple must be purchased and installed from Cummins in order for exhaust temperature values to display. If a thermocouple is not connected to the Power Board or the thermocouple input temperature is less than 200 °F, the Exhaust Temperature will display 0 °F.

To deactivate the Analog Values overlay, press the SCREEN Soft Key to make the overlay disappear from the LCD.

4.3.2 The MENU Soft Key - Settings Menu

If the operator presses the MENU Soft Key from the FPDP User Interface Screen, the Settings Menu Screen appears as shown below.

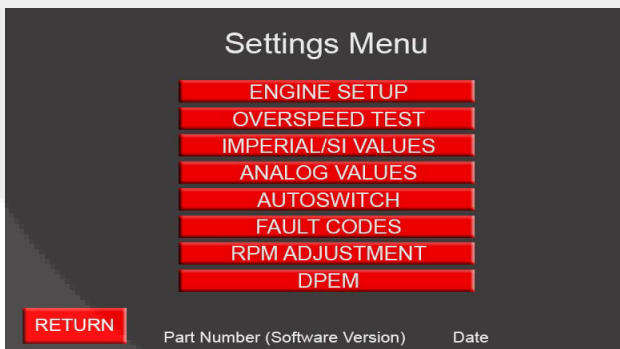

Figure 4-5 Settings Menu Screen (Electronic Engine)

The Settings Menu provides options for further operator input and monitoring of fire pump drive engine parameters. Press the corresponding soft key to access a sub-menu.

4.3.2.1 ENGINE SETUP Screen

The fire pump drive engine was preconfigured with custom options (if applicable) at the factory prior to shipping to the customer. The System Options screen provides a view of the custom configuration that has been set up for your fire pump drive engine. The Cummins Service Department must be notified if any of these parameters are adjusted in the field.

1. Starting at the User Interface Screen (Main Menu), press the MENU Soft Key.
2. As shown in Figure 4-6, press the soft number keys to enter password “806” in the Engine Setup Login screen.

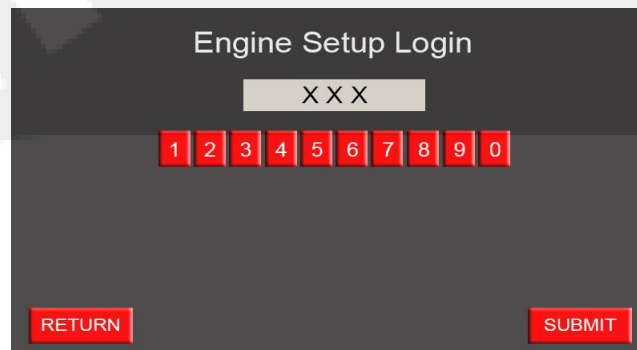

Figure 4-6 Engine Setup Login Screen (Typical)

3. Press SUBMIT to access the Engine Setup screen.

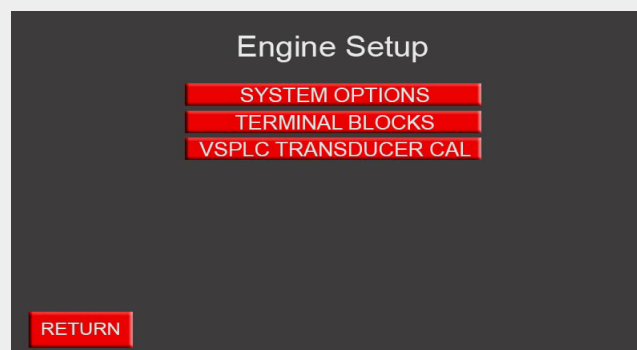

Figure 4-7 Engine Setup Screen (Electronic Engine)

4.3.2.1.1 Engine Setup Screen - SYSTEM OPTIONS

The System Options sub-menu displays the custom configurations of the fire pump drive engine. When



active, the soft buttons turn green in color and display "ON". Conversely, the soft button will turn red in color and display "OFF", if the feature is disabled. To change a numeric data field, tap the data field to access the popup keyboard and enter different data.

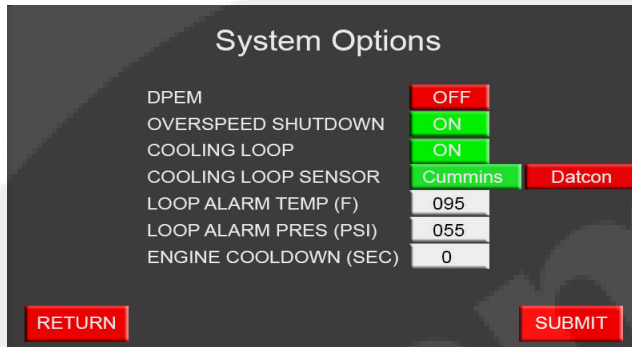

Figure 4-1 System Options Screen (Electronic Engine)

The custom options of the System Options sub-menu include:

DPEM – When active, the FPDP initiates communications with the Digital Panel Expansion Module (DPEM).

OVERSPEED SHUTDOWN – When active, the FPDP shuts the engine fueling off when the engine speed reaches or exceeds 115% of the configured rated speed.

COOLING LOOP – When active, the FPDP will monitor and diagnose the cooling loop parameters.

IMPORTANT: *The COOLING LOOP System Option shall be enabled for FM-approved fire pump drive engines.*

COOLING LOOP SENSOR– The FPDP is configured for two different sensors, a three-terminal 0-5V sensor labeled "Cummins" and a single post-resistive sensor labeled "Datcon". When active, the applicable soft key will display in green.

IMPORTANT: *The COOLING LOOP SENSOR System Option must match the cooling loop sensor installed on the engine for proper decoding and alarming of cooling loop parameters. Ensure that the toggle switch on the FPDP Interface Terminal Strip also matches the cooling loop sensor System Option.*

LOOP ALARM TEMP (F)– When active, the display shows the alarm setpoint for the raw water temperature entering the cooling loop. When the cooling loop is disabled, the alarm will show "XXX".

LOOP ALARM PRES (PSI)– When active, the display shows the alarm setpoint for diagnosing a clogged raw water strainer in the cooling loop. When the cooling loop is disabled, the alarm will show "XXX".

ENGINE COOLDOWN (SEC) (on electronic engines only) - When active, the operator shall denote a specific amount of seconds to idle the fire pump drive engine. When the engine cool down is disabled, the seconds shall be set to "0" (see 4.5 Engine/Turbocharger Cool Down).

Press either RETURN or SUBMIT to return to the Engine Setup menu.

4.3.2.1.2 Engine Setup Screen - TERMINAL BLOCK TEST

The TERMINAL BLOCKS sub-menu provides a convenient means of checking the signal integrity between the fire pump controller and the terminal block interface inside the FPDP.

As shown in Figure 4-1, any of the signals on the terminal block interface can be manually activated by pressing the respective red soft key. When the button turns green, the signal is active.

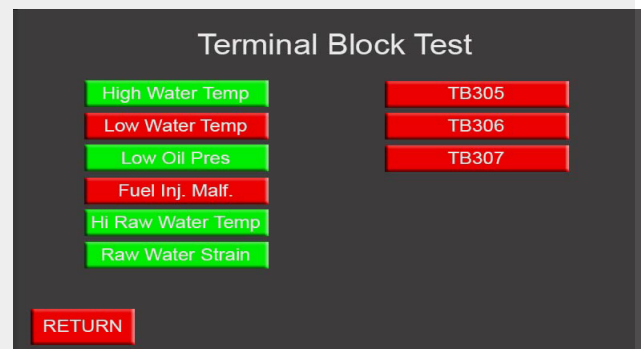

Figure 4-1 Terminal Block Test Screen (Sample)

To perform a Terminal Block Test:

1. Starting at the User Interface Screen (Main Menu), press the MENU soft key;

Operation

2. Press the ENGINE SETUP soft key from the Settings menu;
3. As shown in [Figure 4-6](#), press the soft number keys to enter password “806” in the Engine Setup Login screen.
4. Press the TERMINAL BLOCKS soft key from the Engine Setup menu;
5. Press the soft key corresponding to the terminal block requiring verification;
3. As shown in [Figure 4-6](#), press the soft number keys to enter password “806” in the Engine Setup Login screen.
4. Press the VSPLC TRANSDUCER CAL soft key from the Engine Setup menu.
5. As shown in [Figure 4-1](#), press the VSPLC Offset (PSI) data field to activate the popup keyboard and enter the desired pressure offset.

NOTE: If the selected terminal block soft key turns green, but the pump controller alarm does not activate, troubleshoot the terminal block connection for a B+ or ground signal (see the Section [FPDP Signal and Control Connections](#) or contact your local Cummins Sales and Service representative).

NOTE: For electronic engines, the Fuel Inj. Malf. (fuel injection malfunction) can only momentarily be set.

6. To exit the Terminal Block Test menu, press the RETURN soft key to return to the Engine Setup menu.

NOTE: Oil pressure and coolant temperature alarms will not latch upon backing out of the menu, but instead will be driven directly from datalink values.

4.3.2.1.3 Engine Setup Screen - VSPLC TRANSDUCER CAL

NOTE: The VSPLC TRANSDUCER CAL screen **only** applies to VSPLC fire pump drive engines. The settings in this menu are meaningless unless VSPLC is enabled.

To account for a system pressure differential, the operator may enter a pressure offset. This same pressure offset is used throughout the entire incoming pressure range. To access the VSPLC Transducer Configuration screen:

1. Starting at the User Interface Screen, press the MENU soft key.
2. Press the ENGINE SETUP soft key from the Settings menu.

NOTE: The software limits the pressure offset to +/- 10 PSI with a resolution of 0.1 PSI.

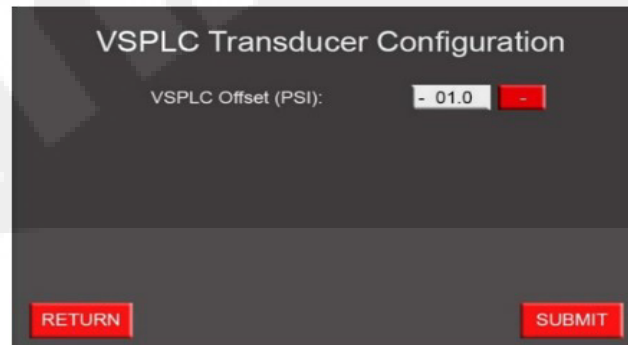

Figure 4-1 VSPLC Transducer Configuration

6. Press SUBMIT.
7. Press RETURN to return to the Engine Setup menu.

4.3.2.2 OVERSPEED TEST Screen

The Overspeed Test Screen allows the operator to simulate an overspeed shutdown for all engine models:

1. Starting at the User Interface Screen (Main Menu), press the MENU soft key.
2. Press the OVERSPEED TEST soft key from the Settings Menu.
3. If necessary, press Adjust Engine Speed (shown in [Figure 4-2](#)) and then use the INC and DEC buttons to increase or decrease the engine speed by increments of ten RPM.



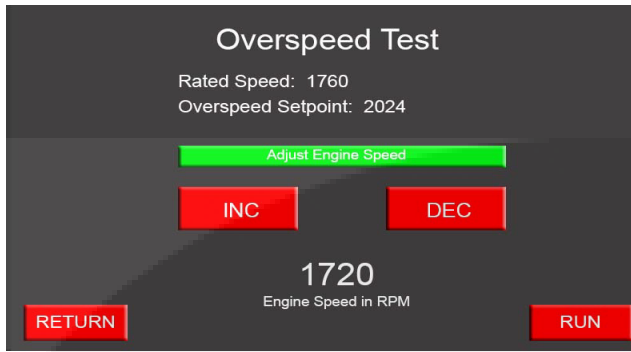

Figure 4-2 Overspeed Test - Adjust Engine Speed

4. Press the RUN soft button.



Figure 4-3 Overspeed Timer

5. When the timer expires (shown in Figure 4-3), “ENGINE OVERSPEED” written in red will flash at the top of the FPDP screen (shown in Figure 4-4).

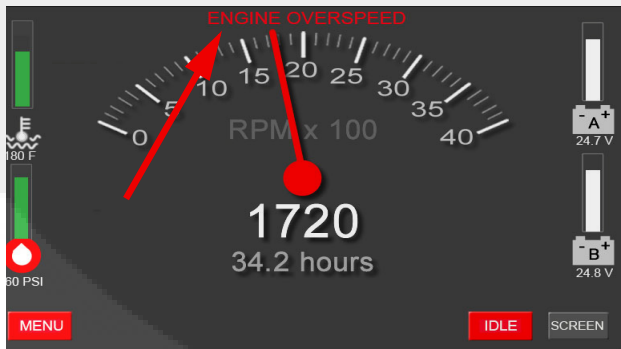

Figure 4-4 Overspeed Test Timer Expired (Sample)

6. The fire pump drive engine will enter MANUAL mode until reset.

7. Press the RESET/STOP Switch on the FPDP to reset the fire pump drive engine.

4.3.2.3 IMPERIAL/SI VALUES Screen

The Imperial/SI Values Screen, shown in Figure 4-5, allows the operator to select Imperial or *Système Internationale* (SI) (also known as metric) units of measurement. The default units of measure are Imperial units of degrees in Fahrenheit and pounds per square inch (PSI), but the user may elect degrees in Celsius or kilo Pascal (kPa).

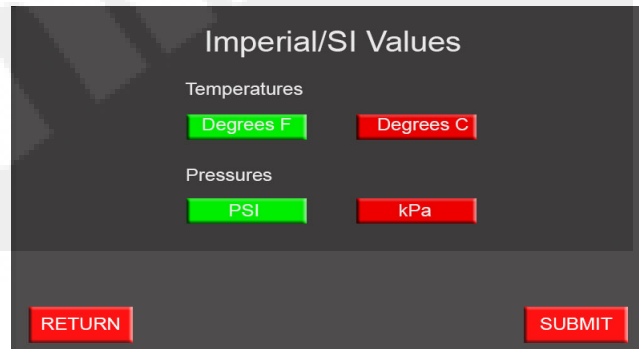

Figure 4-5 Parameter Units Screen (Typical)

To change the displayed units of measurement:

1. Starting at the User Interface Screen (Main Menu), press the MENU soft key.
2. Press the IMPERIAL/SI VALUES soft key from the Settings Menu.
3. Press the soft key for the desired unit of measure.
4. Press the SUBMIT soft key.
5. To exit the Imperial/SI Values menu, press the RETURN soft key.

4.3.2.4 ANALOG VALUES Screen

To view the information about the fire pump drive engine in digital format:

1. Starting at the User Interface Screen (Main Menu), press the MENU soft key.
2. Press the ANALOG VALUES soft key from the Settings Menu.

Operation

3. To exit the Analog Values screen (shown in [Figure 4-6](#)), press the RETURN soft key.

NOTE: The display choice of Imperial or SI values is made using the Imperial/SI Values Screen.

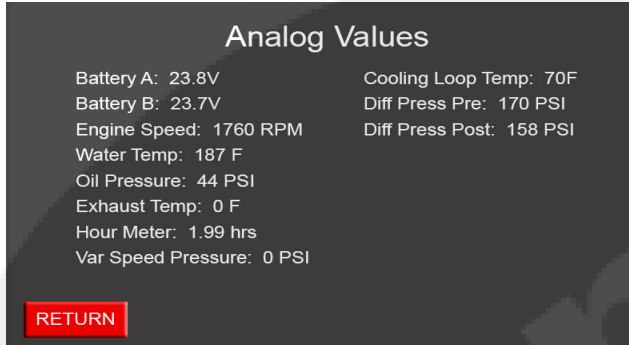

Figure 4-6 Analog Values Screen (Sample)

4.3.2.5 AUTOSWITCH Screen

The National Fire Protection Association (NFPA) 20 Standard, as well as Underwriters Laboratories (UL) and Factory Mutual (FM) Standards, requires redundancy for fire safety systems. If the fuel system is electronically-controlled, switching of ECMs must be controlled automatically. Cummins refers to this process as “ECM Autoswitching.” When the FPDP switches ECMs automatically, the fault code responsible for the last switch can be found on the Autoswitch Screen. The FPDP will activate the ECM keyswitch for fifteen seconds every thirty minutes to validate communications with the ECM.

IMPORTANT: In order to maintain NFPA 20 compliance, autoswitching must be **enabled**.

As shown in [Figure 4-7](#), the Autoswitch Settings screen allows the operator to disable or enable this autoswitch capability.

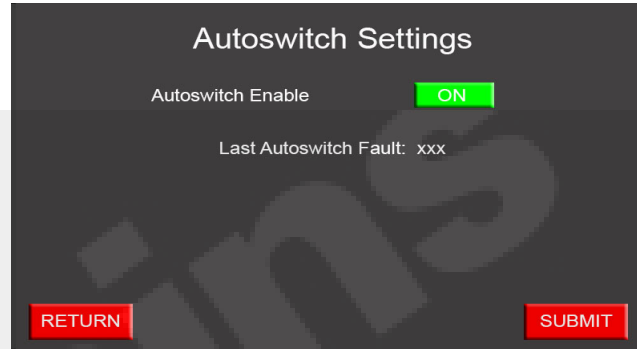

Figure 4-7 Autoswitch Settings Screen (Typical)

To change the autoswitch setting:

1. Starting at the User Interface Screen (Main Menu), press the MENU soft key.
2. Press the AUTOSWITCH soft key from the Settings Menu.
3. Press the ON/OFF soft key - the soft key displayed (in green) indicates which mode has been selected.
4. Press the SUBMIT soft key.
5. To exit the Autoswitch Settings screen, press the RETURN soft key.

4.3.2.6 FAULT CODES Screen

As shown in the Description Section, fault codes diagnosed by the ECM are displayed in a yellow or red overlay box which lies atop the tachometer signal (the engine speed is still digitally displayed) to alert the operator to service the engine as soon as possible. Only the first seven active ECM faults will be displayed in the overlay.

As shown in [Figure 4-8](#), the Fault Codes Screen displays the full list of active faults. To view the information about the fire pump drive engine active faults:

1. Starting at the User Interface Screen (Main Menu), press the MENU soft key.
2. Press the FAULT CODES soft key from the Settings Menu.
3. To exit the FAULT CODES menu, press the RETURN soft key.

For more information about fault codes and their meanings, see the Fault Code Section of this manual or contact your local Cummins Distributor.



Figure 4-8 Fault Codes Screen (Sample)

4.3.2.7 RPM ADJUSTMENT Screen

As shown in Figure 4-9, the RPM Adjustment Screen allows the operator to make on-site adjustments to **FIXED SPEED** fire pump drive engines. Each press of the INC soft key or the DEC soft key will increase or decrease the engine speed setpoint by 10 RPM (not to exceed +/-50 RPM) for electronic engines.

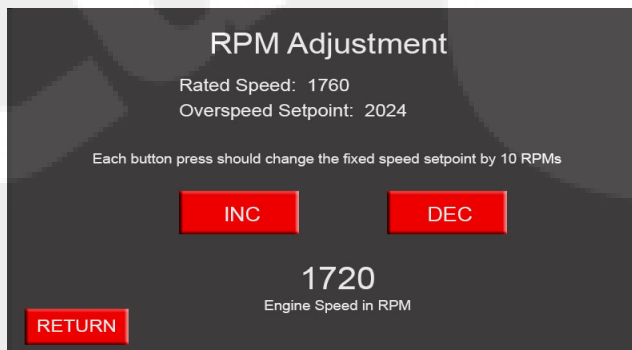

Figure 4-9 RPM Adjustment Screen (Typical)

The engine operating speed was factory set during manufacturing and test procedures. If the speed does not match the engine RPM shown on the factory setting plate, follow these steps to adjust the speed setting:

1. Starting at the User Interface Screen (Main Menu), press the ECM A Selector Switch.
2. Press the MENU soft key.
3. Press the RPM ADJUSTMENT soft key from the Settings Menu.

4. Press either the INC soft key or the DEC soft key to change the ECM RPM setpoint.
5. Press the RETURN soft key.
6. Press the RESET/STOP Switch on the FPDP and wait for thirty seconds.
7. Repeat Steps 1 through 5 for ECM B.

NOTE: The speed setpoint adjustments must be made on each ECM to experience the same system level of performance on the alternate ECM.

IMPORTANT: Never switch from ECM A to ECM B while the engine is running.

4.3.2.8 DPEM (Optional)

As shown in Figure 4-10, the DPEM Screen displays the function name, status, alarm setpoint, and relay associated with the alarm (if applicable) of any custom inputs that are configured on the fire pump drive engine. When an analog input parameter crosses the alarm setpoint or a switched input is active, all information associated with that parameter will turn red in color. To access the DPEM Screen:

1. Starting at the User Interface Screen (Main Menu), press the MENU soft key.
2. Press the DPEM soft key from the Settings Menu.
3. To exit the DPEM Screen, press the RETURN soft key.

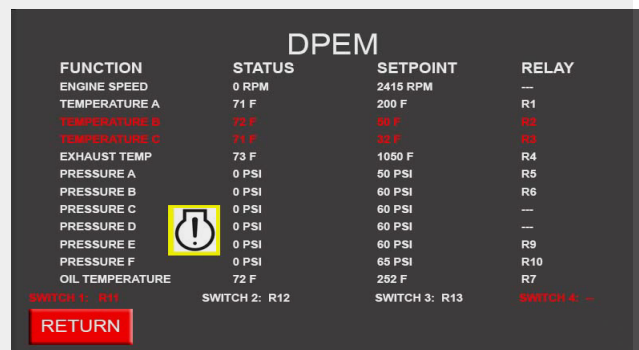

Figure 4-10 DPEM Screen (Sample)

Operation

If communications between the FPDP and DPEM are compromised, the DPEM screen may be accessed by pressing the DPEM soft key that appears on the User Interface Screen (Main Menu) (shown in [Figure 4-11](#)).

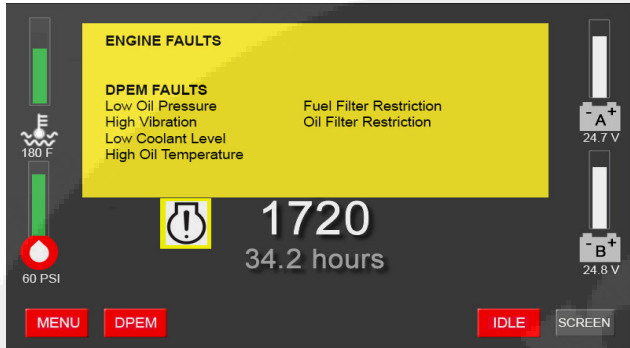

Figure 4-11 DPEM Soft Key

4.4 FPDP Screens and Adjustments in Manual Mode - IDLE Soft Key

NOTE: The IDLE soft key shown in [Figure 4-12](#) displays in red while the engine idle command is inactive. The IDLE soft key will display in green when the engine idle command is active.



Figure 4-12 IDLE Soft Key (Typical)

With the FPDP in manual mode and using the IDLE soft key, the FPDP can now command electronic engines to idle. The operator can choose to idle the fire pump drive engine to warm up the engine for weekly testing and/or to evaluate water leaks during commissioning. To manually place the fire pump drive engine in idle:

1. Select MAN on the AUTO/MAN Mode Switch on the FPDP to place the fire pump drive engine in manual mode.
2. Press the IDLE soft key on the screen.

NOTE: Engaging the IDLE soft key will turn the IDLE soft key display from red to green, engaging the engine idle command.

3. Press the BATT A or the BATT B Momentary Start Switch to start the engine.
4. To disengage manual engine idle, press the IDLE soft key on the screen. The IDLE soft key will return to red in color.

The engine will ramp to rated speed. The engine will also ramp to rated speed (for fixed speed applications) or enter a closed loop VSPLC mode, if enabled, when TB-1 becomes active while the engine is idling.

4.5 Engine/Turbocharger Cool Down

The FPDP has the ability to idle an electronic engine for up to three minutes when a shutdown has been commanded from the fire pump controller. The cool down feature promotes engine turbocharger longevity. During engine cool down, the FPDP will display "Engine Cooldown Active" (shown in [Figure 4-13](#)).

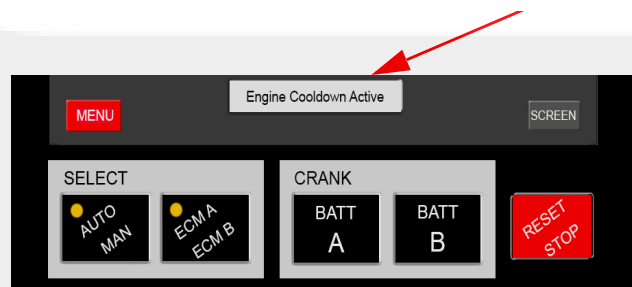

Figure 4-13 Engine/Turbocharger Cool Down (Typical)

During engine cool down, the fire pump drive engine may shutdown automatically - prior to the timer expiring - to protect the engine. The operator also has the option to shut down the engine manually from the fire pump controller or the FPDP during cool down, if necessary.

IMPORTANT: All fire pump drive engines are shipped from the factory with the cool down feature disabled. This feature must be manually enabled by the customer. Prior to enabling the cool down feature, ensure all operators are trained on the operation of this engine cool down feature.

4.5.1 Automatic Shutdown - Cool Down Timer

The fire pump drive engine will automatically shut-down when the Engine Cooldown timer expires.

4.5.2 Automatic Shutdown - Engine Protection

The FPDP will automatically shut the engine off and during engine cool down if:

- Low oil pressure is sensed;
- High coolant temperature is sensed; and/or
- Communications with the ECM are lost.

4.5.3 Manual Shutdown - From the Fire Pump Controller

During cool down, the fire pump drive engine can be shut down manually from the fire pump controller by:

1. Turning the fire pump controller switch to OFF (deactivating TB-1). NOTE: *The FPDP will keep the fire pump drive engine running to idle; AND*
2. Turning the fire pump controller from OFF to MAN (manual) and back to OFF (reactivating and deactivating TB-1). The fire pump drive engine will shut down.

4.5.4 Manual Shutdown - From the FPDP

The engine can also be shutdown manually by pressing the RESET/STOP Switch on the FPDP two times in succession.



This page is intentionally left blank.



Section 5 - Maintenance

5.1 Introduction

Before performing maintenance procedures, read and understand [Section 1 - Safety](#) of this manual. Improper performance or lack of critical information could result in personal injury or equipment damage.

Cummins encourages our customers to perform maintenance and repairs whenever necessary. However, servicing complex components within the normal warranty period may void the Cummins warranty and any specified warranty extended by the manufacturer of Original Equipment Manufacturer (OEM) products. See the warranty information at the beginning of this manual.

Maintenance procedures should be performed by skilled technicians who are familiar with the equipment, local regulations, and service procedures for fire pump drive engine and pump systems. Improper maintenance can damage the engine or the fire pump drive engine, or cause severe personal injury.

The National Fire Protection Association (NFPA) 25 Standard outlines the maintenance tests to be performed to validate automatic and manual operational requirements for field acceptance testing.

Cummins recommends that the engine be maintained according to the Cummins Operation and Maintenance manual for that engine family.

NOTE: *If your engine is equipped with a component or accessory not manufactured by Cummins, refer to the component manufacturer's vendor supplied literature for specific maintenance recommendations.*

5.2 Engine Operation Reports

The engine must always be maintained in top mechanical condition. Proper maintenance of the fire pump drive engine requires documenting regular running reports to include the following:

- Low engine oil pressure.
- Engine surge.
- Erratic operation or frequent shutdowns.
- Any warning lamps flashing or staying illuminated.
- Abnormal coolant or oil temperature.
- Unusual engine noise or vibration.
- Excessive smoke.
- Excessive use of coolant, fuel, or engine oil.
- Any fluid leaks.
- Loose, worn, or damaged parts.

The weekly running report also helps to make provisions for more extensive maintenance, as the reports indicate the necessity.

The Fault Codes displayed on the Fire Pump Digital Panel (FPDP) assist in recording operation irregularities. See [Section 6 - Troubleshooting](#) of the model-specific English manual for a listing of Fault Codes.



Maintenance

Maintenance Record Form

Table 5-1.

Engine Serial Number:			Engine Model:		
Owner's Name:			Equipment Name/Number:		
Date	Hours or Time Interval	Actual Hours	Check Performance	Performed By	Comments
<p><i>NOTE: All maintenance and inspections intervals are accumulative. When performing annual maintenance, also perform maintenance listed under daily, weekly, monthly, and three month intervals.</i></p>					



5.3 Weekly Maintenance

When the engine is running, be alert for mechanical problems that could create unsafe or hazardous conditions.

5.3.1 General

Each week, a general walk-around inspection should include the following areas:

1. Check fluid levels before starting the engine. Check oil pressure and coolant temperatures frequently. Most engine problems give an early warning.
2. Look and listen for changes in engine performance, sound, or appearance that will indicate that service or repair is needed. Be alert for misfires, vibration, excessive exhaust smoke, loss of power, or increases in oil or fuel consumption.
3. Check the engine appearance for excessive heat, wiring short circuits, excessive end-play, vibrations, excessive wear, excessive abrasion, damaged electrical wiring, or loose electrical wiring.
4. Check the engine for odors of diesel fuel, burning rubber, electrical system failure, exhaust fumes, or smoke.

WARNING

Engine fuel is highly flammable and represents an extreme hazard for fire or explosion when exposed to electrical sparks or open flame. Clean up spilled fuel immediately. Keep sources of electrical spark or open flame away from a fuel source.

5.3.2 Air Cleaner Filter and Piping

On a weekly basis, perform the following inspections:

1. Visually inspect the air intake filter and piping daily for blockage, damage to piping, loose clamps, or punctures that can allow debris to enter the engine. If there is a blockage, the service indicator will be activated. Refer to [Figure 2-2](#).

NOTE: Turbocharged engines must be operated at rated revolutions per minute (RPM) and full load to check maximum intake air restriction.

NOTE: Cummins recommends using an air cleaner filter element as listed on the [Engine Data Sheet](#).

CAUTION

Never operate the engine without an air cleaner. Intake air must be filtered to prevent dirt and debris from entering the engine and causing premature wear. Dirt or foreign objects could cause engine damage.

- a. If the red indicator flag is at the raised position in the window, clean or replace the air filter per the manufacturer's recommendation as required. Do not remove the felt washer from the indicator. The felt washer absorbs moisture.
- b. After the air cleaner has been serviced, push the flag in to reset the service indicator.

IMPORTANT: See the [Engine Data Sheet](#) for maximum intake air restriction.

2. Check for corrosion under the clamps and hoses of the intake system piping. Corrosion can allow corrosive products and dirt to enter the intake system. Disassemble and clean as required.
3. Replace any damaged air filter or hoses and tighten loose clamps, as necessary, to prevent the air system from leaking. Torque the hose clamps to the recommended torque value. Refer to the [Torque Tables](#).

5.3.3 Cooling System

CAUTION

Do not remove a coolant pressure/fill cap from a hot engine. Shut down the engine and wait until the coolant temperature is below 50 °C (120 °F) before removing the pressure cap. Heated coolant spray or steam can cause severe personal injury.

Maintenance

On a weekly basis, perform the following inspections on the cooling system:

1. Inspect the cooling water piping, radiator, engine coolant hoses, and hose clamps for loose fittings, leaks, damage, and corrosion.
 - a. Tighten the hose clamps, as necessary.
 - b. Check for cracks, holes, or other damage. Repair or replace as necessary.

CAUTION

Never use a sealing additive to stop leaks in the cooling system. This can result in cooling system plugging and inadequate coolant flow, causing the engine to overheat.

2. With the radiator at ambient temperature, press down, unscrew, and remove the pressure cap as shown in [Figure 2-1](#).
 - a. Ensure that the coolant level is visible by checking the coolant level sight gauge.
 - b. Add coolant, as required. **DO NOT OVER-FILL!**

NOTE: Supplemental engine coolant should be a mixture of 50% ethylene glycol antifreeze and 50% water to avoid engine damage.

3. Check the antifreeze concentration at least six times a year or whenever coolant is added to the cooling system by using a refractometer.
4. Drain a small amount of coolant from the return line petcock and inspect the coolant for excessive rust or particulate matter. Change the coolant more frequently if particles are present.

CAUTION

Do not mix coolant brands or chemical solutions, as this could damage the cooling system. Keep a record of the coolant concentration and manufacturer with the engine maintenance records.

5. Check for soft, overly-pliant hoses, oxidation, and loose hose clamps. Torque the hose clamps to the recommended torque value. Refer to the [Torque Tables](#). Replace damaged hoses and clamps as required.

6. Check the radiator for leaks, damage, and dirt buildup. Clean and repair as required.

5.3.4 Engine Oil System

WARNING

Perform the specific checks in this section only after the engine is fully stopped. Unless tests require engine operation, disconnect the battery leads from the batteries (negative terminal first). Contact with exposed or moving components can cause severe personal injury.

Inspect the engine oil system on a weekly basis following these steps:

1. For accurate dipstick readings, shut off the engine and wait approximately ten minutes to allow the oil in the upper portions of the engine to drain back into the crankcase.
2. As shown in [Figure 5-1](#), check the oil level at the engine dipstick.

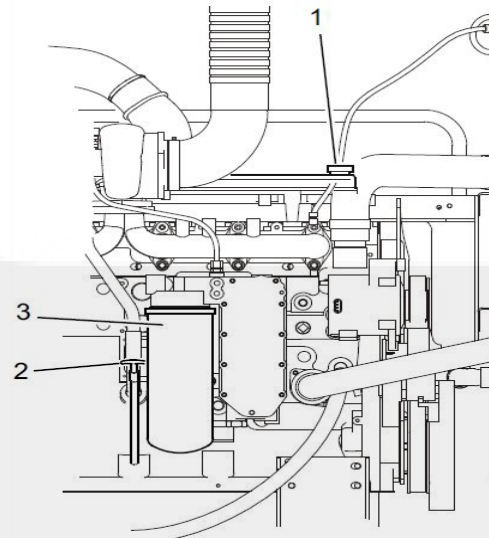

1. Oil Fill Port (on valve cover)
2. Oil Level Dipstick
3. Engine Oil Filter

Figure 5-1 Oil Level Dipstick

- If the oil level is greater than the high mark (H), drain the excess oil and recheck the level.
- If the oil level is consistently below normal after a fill, check for leaks, loose or damaged gaskets, or oil in the coolant system. If the oil level is

below the low mark (L), add the equivalent type oil.

NOTE: Cummins recommends using Premium Blue® 15W-40 Multi-viscosity Lubricating Oil or equivalent.

5.3.5 Fuel System

WARNING

Engine fuel is highly flammable and represents an extreme hazard for fire or explosion when exposed to electrical sparks or open flame. Clean up spilled fuel immediately. Keep sources of electrical spark or open flame away from a fuel source.

To inspect the fuel system:

1. Shut off the engine.
2. Inspect the fuel supply line, return line, filter and fittings for cracks or abrasions.
 - a. Ensure the lines are not rubbing against anything that could damage the fuel system hoses. Repair any leaks or alter line routing to eliminate wear immediately.
 - b. Relieve fuel line pressure by carefully loosening the fuel inlet line.

NOTE: Refer to the [Engine Data Sheet](#) for Cummins recommended replacement components.

5.3.6 Engine Exhaust System

With the engine operating, inspect the entire exhaust system: exhaust manifold, exhaust flex pipe, muffler, and piping.

Check for leaks at all connections, welds, gaskets, and joints. Make sure that the exhaust pipes are not heating surrounding areas excessively. Repair any leaks immediately.

5.3.7 Electrical Supply and Controls

Check the terminals on the starting batteries for clean and tight connections. Loose or corroded connections create resistance which can hinder starting. Inspect the FPDP harness connections to be sure they are secure.

5.3.8 Crankcase Ventilation Hose

Inspect the crankcase ventilation hose for wear, damage, sludge, blockage, or dirt buildup (refer to [Figure 2-1](#)). Clean the ventilation hose, if obstructed or blocked. Replace a worn or damaged hose.

5.3.9 Batteries

CAUTION

Batteries can emit explosive gases during charging. To reduce the possibility of personal injury, always ventilate the battery compartment before servicing the batteries.

CAUTION

To reduce the possibility of arcing, remove the negative (-) battery cable first and attach the negative (-) battery cable last.

For proper weekly maintenance of the batteries:

1. Keep the batteries clean by wiping them with a damp cloth whenever dirt appears excessive.
2. Use a battery hydrometer to check the specific gravity of the electrolyte in each battery cell. A fully-charged battery will have a specific gravity of 1.260. Replace the battery, if the specific gravity reading is below 1.215.
3. Check the battery wiring and cable connections for loose, corroded, worn, or damaged cables. Check both connectors at the alternator, battery connections, and engine grounding lug (near the starter motor).
 - a. If the battery cables are corroded, remove the battery cable clamps, starting with the negative (-) battery cable.
 - b. Use a fine emery cloth or a wire brush to clean the cable clamps and battery cables. The metal should be shiny.
 - c. Wash the battery terminals with a solution of baking soda and water (2 oz (1/4 cup) baking soda to 0.94 liter (1 qt) of water).
 - d. Be careful to prevent the solution from entering the battery cells, and flush the batteries with clean water when done.

Maintenance

- e. After cleaning the connections, coat the terminals with a light application of petroleum jelly.
- f. Reinstall and tighten the cable clamps.
5. Ensure that the oil pressure is greater than 69 kPa (10 psi).
6. Check that the coolant temperature is between 70 °C (158 °F) and 107 °C (225 °F).

WARNING

Battery electrolyte (sulfuric acid) is highly caustic and can burn clothing and skin, or cause blindness. Wear protective clothing, impervious neoprene gloves, safety goggles, or full-face shield when working with the batteries.

4. Check the electrolyte level in the batteries monthly. If low, fill the battery cells to the bottom of the filler neck with distilled water.
5. Check for continuity between terminals using a digital multimeter or other test equipment. Also check the insulation resistance to ground. Correct any electrical faults.
6. Reinstall the battery cables; attach the negative (-) battery cable last.

5.3.10 Engine Test Run

Start the engine at least once a week for a minimum of thirty minutes with as much load as possible. Periods of no-load operation should be held to a minimum, because unburned fuel tends to accumulate in the exhaust system. Refer to the operating instructions in [Section 4 - Operation](#).

Check that the engine starts and operates at the recommended fire pump drive engine speed specification and inspect the following:

1. Check that the engine oil pressure is indicated on the gauge within fifteen seconds after starting.
2. Check that the engine has attained a normal running temperature after running the engine for a minimum of thirty minutes.
3. Observe that the engine is operating at the proper operating speed. (If the engine is not operating at the proper speed, see [Section 5.3.11 Engine Operation Checks](#).)
4. Check for unusual engine noise. Listen for any unusual engine noise which can indicate that service is required.

7. Check that both battery voltmeters indicate 12 VDC for standard or 24 VDC for optional operating systems.
8. Check that the air filter service indicator has not popped-up, indicating an air filter blockage. Replace the air filter as required.

End the test run by pressing and holding the over-speed RESET/STOP switch until the engine stops.

5.3.11 Engine Operation Checks

The following service inspections ensure that the engine starts and operates properly under normal conditions.

WARNING

Before equipment operation, ALL guards, covers, and protective devices MUST BE in place and securely fastened. Serious personal injury could result from contact with exposed or moving components.

5.3.11.1 Crank Termination Setpoint

The speed switch crank termination setpoint is factory-set at 600 RPM and should not be changed from this value.

5.3.11.2 Engine Speed Adjustment

The electronic engine operating speed was factory set during manufacturing and test procedures. If the speed unintentionally does not match the engine RPM shown on the factory setting plate, refer to [Section 4 - Operation: RPM Adjustment Screen](#).

5.3.12 Engine Coolant Heater

NOTE: Perform this inspection procedure twenty-four hours after shutting off the engine.

The engine coolant heater must maintain an engine coolant temperature of 49 °C (120 °F) or above. The engine block must be warm to the touch (38 °C (100 °F)) in the water jacket areas (see [Figure 2-2](#)).

If the heater does not appear to be working correctly, contact a Cummins Authorized Repair Location.



5.4 Annual Maintenance

All checks or inspections listed under previous maintenance intervals must also be performed at the time of the annual maintenance, in addition to those listed *only* under the annual maintenance interval.

5.4.1 Electrical Components

CAUTION
AVOID SERVICING complex components such as: printed circuit boards, programmable controllers, and ECMs not specifically authorized by Cummins. Contact a Cummins Authorized Repair Location before performing any extensive maintenance.

CAUTION
To reduce the possibility of arcing, remove the negative (-) battery cable first and attach the negative (-) battery cable last.

The electrical components of the fire pump drive engine must be thoroughly inspected on an annual basis. Remove the battery terminal cables, starting with the negative (-) cable first and check the following:

1. Inspect the electrical wiring harness, electrical terminal connections, and electrical plug-ins for secure, clean electrical contacts, worn or damaged insulation, burnt wires, broken wires, and loose connections (see [Figure 2-1](#)).
 - a. Clean and tighten any loose electrical connections.
 - b. Repair or replace worn, damaged, burnt, or poorly insulated wiring immediately.

IMPORTANT: Refer to the vendor-supplied literature for recommended maintenance procedures.

2. Inspect the function of all gauges, voltmeters, switches, and warning lamps on the FPDP. Replace the FPDP if any are not functioning properly.
3. Reinstall the battery cables; attach the negative (-) battery cable last.

5.4.2 Turbocharger Mounting Nuts

As shown in [Figure 5-2](#), check the turbocharger mounting nuts and torque the mounting nuts to the recommended torque value. Refer to the [Torque Tables](#).

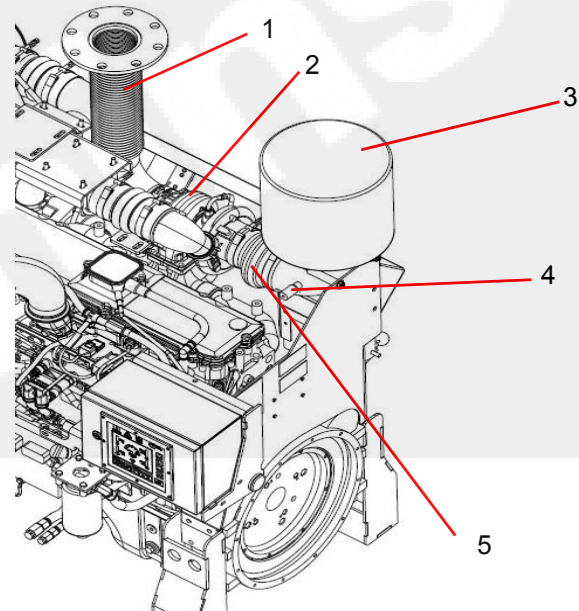

1. Exhaust Flex Connection
2. Turbocharger
3. Air Cleaner/Filter
4. Service Indicator
5. Air Cleaner Piping

Figure 5-2 Turbocharger (typical)

5.4.3 Engine Supports

CAUTION
Loose engine mount bolts or damaged brackets can cause engine misalignment or excessive vibration. These conditions can cause engine or pump damage.

Refer to [Figure 2-1](#) for the location of the engine supports and inspect all engine supports for cracks or loose hardware. Check the torque on the engine support mounting capscrews. Torque the engine mounting cap screws to the support bracket. Refer to the [Torque Tables](#) for recommended torque values.

5.4.4 Fuel Pumps and Filters

As shown in [Figure 5-3](#), inspect the fuel injection pump mounting nuts (including the support bracket) for loose or damaged hardware. Inspect the fuel line hoses and fuel filters for wear, damage, loose fittings,

Maintenance

and leaks. Repair or replace damaged hoses and filters as required.

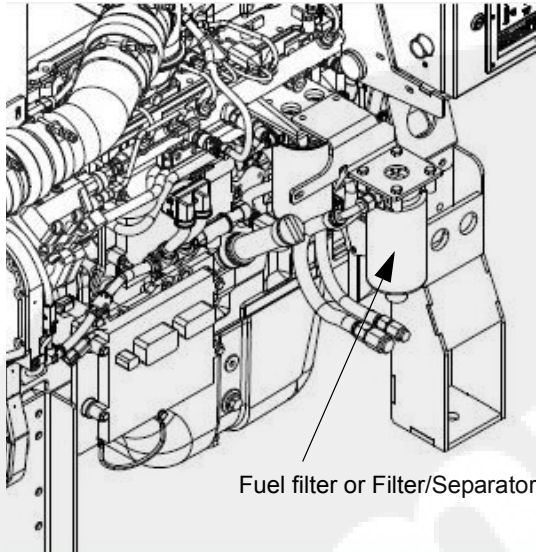

CFP-058-1

Figure 5-3 Fuel Pumps (typical)

! WARNING

Engine fuel is highly flammable and represents an extreme hazard for fire or explosion when exposed to electrical sparks or open flame. Clean up spilled fuel immediately. Keep sources of electrical spark or open flame away from a fuel source.

! WARNING

Do not open the fuel filter/water separator drain valve or dismantle the fuel lines on the high-pressure fuel system with the engine running. High pressure fuel spray from an operating engine can cause serious personal injury or fire hazard.

To change the fuel filters:

1. Shut off the engine.
2. Close any fuel valves (if equipped) to prevent fuel from draining or siphoning.
3. Clean the area around the fuel filter or fuel/water separator heads.

NOTE: Refer to the [Engine Data Sheet](#) for filter replacement recommendations.

4. Remove the spent filter canisters using a filter wrench.
5. Clean the filter mounting head surfaces of sludge buildup and foreign particles. Ensure mating gasket surfaces are clean.
6. Lubricate the gasket seals with clean SAE 15W-40 lubricating oil.
7. Center the filter ring on the threaded mounting nipple. Screw the filter canister onto the mounting flange until the gasket is snug against the mounting flange, then tighten an additional 1/4 turn.
8. Open the fuel supply valves (if equipped).

! CAUTION

Mechanical over-tightening can distort the threads or damage the filter element seal.

9. Press either the CRANK BATT A or CRANK BATT B button to start the engine to allow the fuel to flow through the system.
10. Depress the contactor switch for up to fifteen seconds or until the engine starts. Repeat up to three times, if necessary.

! CAUTION

To prevent damage to the starter, do not engage the starting motor more than fifteen seconds. Wait fifteen seconds between each start attempt.

IMPORTANT: If the engine does not start after three attempts, check the fuel supply system. Absence of blue or white exhaust smoke during cranking indicates no fuel is being delivered.

NOTE: Engines used in fire pumps or standby service are expected to immediately accelerate from crank to full load.

5.4.5 Engine Oil and Filter

Engine oil becomes contaminated and essential oil additives are depleted with use. The amount of contamination is related to the total amount of fuel and oil consumed. Change the oil at least once annually.

NOTE: For composite oil pans, always use a new sealing washer on the oil drain plug. Hold the external locking nut in place while tightening the oil drain plug.

IMPORTANT: If the engine oil is drained from the oil pan to make an engine repair, new oil must be used.

! WARNING

To reduce the possibility of personal injury, avoid direct contact of hot oil with your skin. Some state and federal agencies have determined that used engine oil can be carcinogenic. Prolonged, repeated contact can cause skin disorders or other bodily injury. Wash thoroughly after contact. Avoid inhalation of vapors and ingestion of used engine oil. Dispose of the oil in accordance with local environmental regulations.

To change the oil and filter to remove the contaminants suspended in the oil:

1. Operate the engine until the coolant temperature reaches 70 °C (158 °F). Shut the engine off.
2. Place an appropriate container under the oil pan drain plug. Refer to the [Engine Data Sheet](#) for oil pan capacity.
3. Remove the oil drain plug and drain the oil immediately to make sure all the oil and suspended contaminants are removed from the engine.
4. Remove the oil filter (see [Figure 5-4](#)) following these steps:
 - a. Clean the area around the engine oil filter canister. Use a filter wrench to remove the filter.
 - b. Remove and discard the O-ring seal if it has remained attached to the mounting flange. Clean the filter mounting flange with a clean lint-free cloth.
 - c. Apply a light film of 15W-40 lubricating oil to the replacement filter gasket before installing the filter.
5. Fill the oil filter with a high-quality 15W-40 multi-viscosity lubricating oil, such as Premium Blue®, or its equivalent.

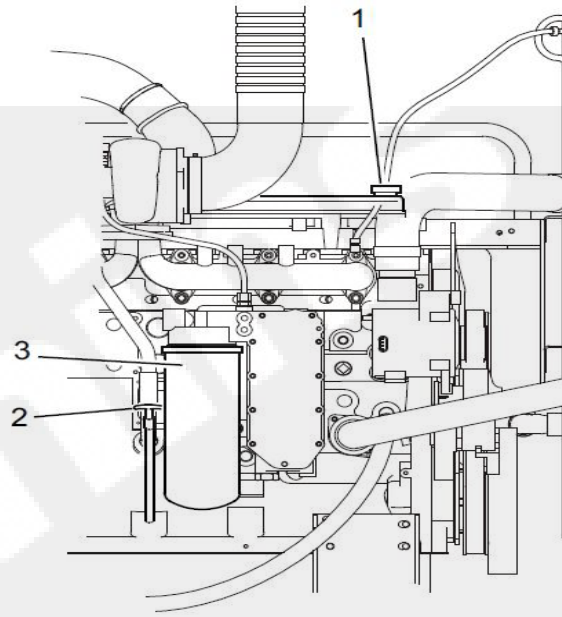

1. Oil Fill Port (on valve cover)
2. Oil Level Dipstick
3. Engine Oil Filter

Figure 5-4 Oil Filter and Oil Level Dipstick (Typical)

6. Center the filter ring on the threaded mounting nipple. Screw the filter canister onto the mounting flange until the gasket is snug against the mounting flange. Then tighten an additional 1/4 turn.

! CAUTION

Mechanical over-tightening can distort the threads or damage the filter element seal.

NOTE: Cummins recommends using oil filter replacement parts as outlined in the [Engine Data Sheet](#).

7. Check and clean the oil pan drain plug threads and sealing surface. Install the oil pan drain plug. Torque the plug according to the [Torque Tables](#).
8. Fill the engine to the proper level with clean, high quality 15W-40 oil at the fill port.

! CAUTION

If no oil pressure is noted within fifteen seconds after the engine is started, shut down the engine to reduce the possibility of internal damage.

Maintenance

- Restart the engine and let it run for approximately one to two minutes.
- Stop the engine.
- Wait approximately fifteen minutes to let the oil drain from the upper parts of the engine.
- Check the oil level again. Add oil as necessary to bring the oil level to the H (high) mark on the dipstick.

5.4.6 Drive Shaft

It is recommended that proper lubrication to drive shafts be completed on a regular schedule according to these steps:

- Remove the drive shaft guards.
- Wipe the grease fittings and grease gun nozzle with a clean cloth to avoid contamination.
- Add grease to the drive shaft universal joint grease fittings (see [Figure 3-2](#)).
- Wipe excess grease from the grease fittings.

NOTE: Cummins recommends using a good quality semi-synthetic, molybdenum-fortified NLGI #2 lithium complex grease which protects from -47 to 204 °C (-54 to 400 °F).

5.4.7 Coolant Pump/Alternator Belt

On some engine models, the pump and alternator belt drives both the pump and alternator.

To inspect the coolant pump and the alternator belt:

- Press the AUTO/MAN button on the FPDP to place the fire pump drive engine in MANUAL operation.
- Disconnect both batteries at their terminals. Remove the negative (-) cable first.
- Remove the belt guard capscrews and the belt guard. Set aside for re-installation. Visually inspect the belt for frayed, worn, missing pieces, or cracked belt surfaces. Check the belt for intersecting cracks.

CAUTION

Belt damage can be caused by: incorrect tension, incorrect size or length, pulley misalignment, incorrect installation, severe operating environment, and/or oil or grease on the belt or pulley.

NOTE: Transverse cracks (across the belt width) are acceptable. Longitudinal cracks (direction of belt length) that intersect with transverse cracks are not acceptable. Replace the belt if it is cracked, frayed, or damaged.

- If the belt condition is acceptable, check the belt tension. There are two ways to check the belt condition:

NOTE: Belts with glazed or shiny surfaces indicate belt slippage. Correctly installed and tensioned belts will show even pulley and belt wear.

CAUTION

Disconnect the batteries (negative cable first) before performing service on the fire pump drive engine or on any of its controls.

- Use the Cummins belt tension gauge (Part Number 3822524) to measure the drive belt tension in the center span of the belt between the idler and alternator pulleys. Ensure that the belt tension is set to the specifications outlined in the Engine Operation manual.
 - Use the deflection method and measure the belt tension in the center span of the belt between the alternator and idler pulleys. If the belt deflection is more than one belt thickness per foot of pulley center-to-center distance, adjust the belt tension.
- Reinstall the battery cables; attach the negative (-) battery cable last.

5.4.8 Radiator Pressure Test

If internal leakage in the radiator is suspected, a radiator pressure test may be performed prior to removal from the engine.

NOTE: Use Teflon™ tape or other pipe sealant when installing the test setup in order to prevent leaks.

NOTE: The size of fittings required on the water outlets and inlets are listed on the [Engine Data Sheet](#).



To test the radiator pressure:

1. Install an adapter at the water outlet of the radiator.
 2. Install a pressure test setup with 689 kPa (100 psi) pressure gauge at the water inlet to the radiator.
 3. Apply air pressure at 414 kPa (60 psi).
 - a. Isolate the pressure source and monitor the pressure gauge for five minutes.
 - b. There should be no change in pressure for the duration of the test.
 4. After testing, release the pressure. Remove the tubing adapters, plug, and test equipment.
 5. If leakage is detected, the radiator must be removed, repaired, or replaced, as necessary.
3. Inspect the turbocharger turbine wheel for cracks in the housing or turbine blades, missing blades, mechanical binding, eccentric motion, or excessive end-play.
 4. Replace the turbocharger if damage, excessive end-play, binding, wear, or eccentric motion is found. Contact a Cummins Authorized Repair Location for replacement.

IMPORTANT: *The turbocharger must be removed for replacement or rebuild if the clearance is beyond the limits, the housing is cracked, or the turbine wheel is damaged.*

5. Reinstall the air intake filter and exhaust piping. Tighten the clamps. Torque the loosened clamps to the recommended torque value. Refer to the [Torque Tables](#).

5.5 Every Two Years

All checks or inspections listed under daily or previous maintenance intervals must also be performed at this time, in addition to those listed under this maintenance interval.

5.5.1 Coolant Pump

Inspect the coolant pump for eccentric motion, mechanical binding, excessive end play, seal damage, and excessive grease or coolant leakage around the pump shaft.

Replace with a new or rebuilt pre-lubricated unit, as necessary. Contact a Cummins Authorized Repair Location for replacement.

5.5.2 Radiator Cooling System

[Figure 5-5](#) illustrates the radiator cooling system. The cooling system must be clean to work properly. If the system shows excessive mineral buildup, particulate matter, scale, oxidation, or oil contamination, drain and flush the cooling system. If the coolant is excessively dirty or is mixed with oil, contact a *Cummins* Authorized Repair Facility.

5.4.9 Turbocharger

As shown in [Figure 5-2](#), follow these steps to thoroughly inspect the turbocharger:

1. Visually inspect the air intake filter and piping according to the steps outlined in [Section 5.3.2](#).

NOTE: *Turbocharged engines must be operated at rated revolutions per minute (RPM) and full load to check maximum intake air restriction.*

NOTE: *Cummins recommends using an air cleaner filter element as listed on the [Engine Data Sheet](#).*



CAUTION

Never operate the engine without an air cleaner. Intake air must be filtered to prevent dirt and debris from entering the engine and causing premature wear. Dirt or foreign objects could cause engine damage.

2. Remove the air intake and exhaust piping from the turbocharger.



Maintenance

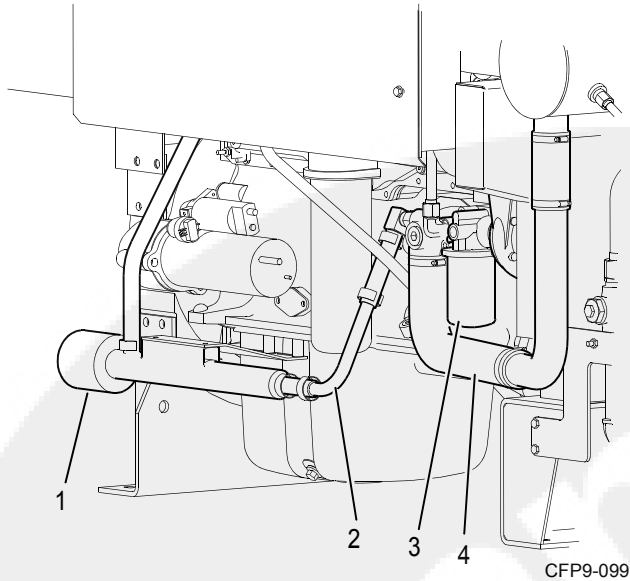

1. Engine Coolant Heater
2. Engine Coolant Heater Coolant Hose
3. Coolant Filter
4. Lower Coolant Tube

Figure 5-5 Engine Coolant Drain - Radiator

! WARNING

Do not remove the pressure/fill cap from a hot engine. Shut down the engine and wait until the coolant temperature is below 50° C (120° F) before removing the pressure cap. Heated coolant spray or steam can cause severe personal injury.

1. Disconnect both batteries at their terminals. Remove the negative (-) cable first.
2. Press down, unscrew, and remove the radiator pressure/fill cap. The cap must be removed to allow air to vent the cooling system during the draining process.
3. Disconnect the engine coolant heater power supply before draining the cooling system.
4. Place a container that will hold at least 57 liters (15 gal) of liquid under the lower coolant hose of the radiator.
5. Ensure that the coolant filter shut-off valves are OPEN.

6. Open the drain petcock on the lower coolant tube, allowing the coolant to drain into the waste contain
7. When the system is empty, move the container under the engine coolant heater.
8. Disconnect either end of the engine heater coolant hose and drain the engine heater.

! CAUTION

Coolant is toxic. Avoid prolonged and repeated skin contact with used antifreeze - wash thoroughly after contact. Prolonged, repeated contact can cause skin disorders. Dispose of waste anti-freeze in accordance with local environmental regulations.

9. Flush with clean fresh water or heavy-duty heat exchanger cleaner. Follow the manufacturer's directions on the product container.

NOTE: Some cooling system cleaners or commercial solvents require a soapy water rinse after use. Follow the directions on the cleaning solution or solvent.

! CAUTION

Over-concentration of antifreeze or use of high silicate antifreeze can damage the engine. Do not use more than 50% antifreeze in the mixture unless additional freeze protection is required. Antifreeze at 68% concentration provides the maximum freeze protection, and must never be exceed under any condition. Antifreeze protection decreases above 68%.

10. When the flushing water has fully drained, use a filter wrench to remove the water coolant filter from the filter housing.
 - a. Clean the filter housing gasket mount of dirt buildup, oxidation, or particulate matter with a clean cloth.
 - b. Coat the replacement filter gasket with a light coating of 15W-40 lubrication oil.
11. Center the filter ring on the threaded mounting nipple. Screw the filter canister onto the mounting flange until the gasket is snug against the mounting flange, then tighten and additional 1/4 turn. If using a soapy water solution, flush again

with clear water. Allow time for the water to fully drain.

glycol in most climates. Contact your local Cummins Authorized Repair Location for additional information.

CAUTION

Mechanical over-tightening can distort the threads or damage the filter element seal.

NOTE: Recommendations on filter replacements and fill rates can be found on the model specific [Engine Data Sheet](#).

12. Reconnect the engine heater coolant hose and close the drain petcock and the lower coolant tube petcock.

NOTE: During filling, air must be vented from the engine coolant passages. The air vents through the coolant filler port. The fill rate can be found in the model-specific [Engine Data Sheet](#).

13. Fill the coolant tanks with the proper antifreeze. Use a mixture of 50% water and 50% ethylene-glycol base or propylene-glycol antifreeze (or pre-mixed solution) to protect the engine to -37° C (-34° F) year-around.

CAUTION

Use soft or distilled water in the coolant mixture. Contaminants in hard water neutralize the corrosion inhibitor components. Water must not exceed 300-ppm hardness or contain more than 100 ppm of either chloride or sulfate.

CAUTION

Never use a sealing additive to stop leaks in the cooling system. This can result in cooling system blockage or restricted coolant flow, causing the engine to overheat.

NOTE: Cummins recommends using Fleetguard® ES COMPLETE™ Ethylene-Glycol (EG) or Fleetguard® Propylene-Glycol (PG) Plus™ antifreeze/coolants. Both products are available in concentrated or pre-mixed formulations. Use a 50% concentration level (40% to 60% range) of ethylene-glycol or propylene-

Ethylene-Glycol

Propylene-Glycol

40% = -23° C (-10° F)	40% = -21° C (-6° F)
50% = -37° C (-34° F)	50% = -33° C (-27° F)
60% = -54° C (-65° F)	60% = -54° C (-65° F)
68% = -71° C (-96° F)	68% = -63° C (-82° F)

CAUTION

The system must be filled properly to prevent air locks. During filling, air must be vented from the engine coolant passages.

14. Check the condition of the pressure/fill cap on the radiator.
 - a. If the pressure/fill cap seal is worn, damaged, missing, or the pressure spring is damaged or shows signs of sticking, replace the fill cap.
 - b. Reinstall the radiator fill cap.
15. Reinstall the battery cables; attach the negative (-) battery cable last.
16. Operate the engine until it reaches a temperature of 82° C (180° F), and check for coolant leaks.
17. Ensure that the coolant level is just below the fill neck.

5.6 Every Four Years

All maintenance checks and inspections listed in previous maintenance intervals must also be performed at this time.

Cummins recommends performing maintenance on valve lash settings.

CAUTION

Disconnect both batteries (negative cable first) before performing service on the fire pump drive engine or on any of its controls. Wear safety glasses when disconnecting batteries!

Maintenance

CAUTION

Valve lash maintenance should be performed by a skilled technician. Improper maintenance can damage the engine or cause severe personal injury. Contact your local Cummins Authorized Repair Location before performing any extensive maintenance.

5.6.1 Coolant Thermostat Removal/Installation

The thermostat regulates the temperature of the engine coolant circulating through the engine cooling system. Refer to the engine manual for complete instructions.

CAUTION

Always use the correct thermostat, and never operate the engine without a thermostat installed. The engine can overheat if operated without a thermostat because the path of least resistance for the coolant is through the bypass to the pump inlet.

1. As shown in [Figure 5-6](#), remove the upper coolant hose clamps and upper coolant hose at the thermostat housing.
2. Remove the (2) thermostat housing flange cap screws and the thermostat flange.
3. Remove the thermostat and gasket from the housing.
4. Clean the housing flange faces of dirt buildup, oxidation, and sludge.
5. If still in good condition, re-install the thermostat in the housing.

IMPORTANT: *Inspect the seal on the thermostat housing flange surface and - if damaged or cracked - apply a new seal.*

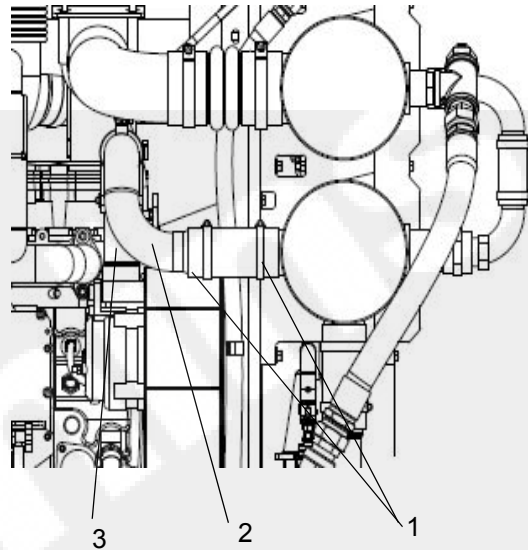

1. Hose Clamps
2. Upper Coolant Hose
3. Thermostat Housing

Figure 5-6 Thermostat Housing (typical)

NOTE: *Recommendations on thermostat replacement components can be found on the [Engine Data Sheet](#).*

6. Replace the thermostat flange and cap screws.

5.6.2 Coolant Pump/Alternator Belt Replacement

Replace the coolant pump/alternator belt if it is cracked, frayed, or has pieces of material missing.

1. Remove the belt guard.
2. Use a 3/8" drive ratchet or breaker bar to rotate the tensioner arm away from the belt and remove the belt.
3. Check the belt tensioner cap screw torque. For recommended torque values, refer to the [Torque Tables](#).
4. Check the tensioner arm, pulley, and stops for cracks. If any cracks are noticed, the tensioner must be replaced.
5. Verify that the tensioner arm stop is not in contact with the spring casing stop. If either stop is touching, the tensioner must be replaced.
6. Inspect the tensioner for evidence of the tensioner arm contacting the tensioner cap.

If there is evidence of the two areas making contact, the pivot tube bushing has failed and the tensioner must be replaced.

7. Check the tensioner bearing.
 - a. Rotate the belt tensioner pulley. The pulley should spin freely with no mechanical binding, eccentric motion, or excessive end-play.
 - b. If the arm rotates with mechanical binding, eccentric movement, or excessive end play, replace the tensioner.
8. Inspect the clearance between the tensioner spring case and the tensioner arm for uneven bearing wear.

If the clearance exceeds 3 mm (0.12 in) at any point, the tensioner must be replaced as a complete assembly. Contact a Cummins Authorized Repair Location for replacement.

NOTE: Experience has shown that tensioners generally will show a larger clearance gap near the lower portion of the spring case, resulting in the upper portion rubbing against the tensioner arm. Always replace the belt when a tensioner is replaced.

9. After checking the torque, use a 3/8" drive ratchet or breaker bar to rotate the tensioner slowly away from the area of belt contact.
10. Install the replacement drive belt.

CAUTION

To prevent pulley or belt damage, do not roll a belt over the pulley or pry it on with a tool. Move the tensioner arm away from the belt area before installing the drive belt.

11. Check the location of the drive belt on the belt tensioner pulley. The belt should be centered on, or centered close to, the middle of the pulley.
12. Reinstall the belt guard.

CAUTION

Unaligned belts, either too far forward or backward, can cause belt wear, belt roll-off failures or increase uneven tensioner bushing wear.

5.6.3 Radiator Cooling System

The radiator should be removed and cleaned internally at least once every four years.

1. Press the AUTO/MANUAL mode switch to select the MANUAL position.
2. Disconnect both batteries at their terminals. Remove negative (-) cable first. Install the negative (-) cable last.

CAUTION

Both batteries must be disconnected before performing service on the fire pump engine or on any of its controls. Wear safety glasses when disconnecting batteries!

3. Disconnect the inlet and outlet piping from the radiator. Refer to [Figure 2-2](#).

WARNING

Cleaning chemicals may be caustic and cause skin irritation. Follow the instructions on cleaning containers. Wear protective clothing, eye wear, and rubber gloves when working with cleaning solutions. Dispose of solvents and cleaning solutions properly.

WARNING

Do not remove the radiator cap from a hot engine. Hot steam will cause serious personal injury. Remove the coolant system pressure cap slowly and close the shut-off valve(s), if equipped, before removing the coolant filter. Failure to do so can result in personal injury from heated coolant spray.

4. Flush the radiator internally with cleaning solution. If the system shows mineral build-up, scale, rust, or oil, clean with a heavy-duty engine coolant cleaner and follow the manufacturer's directions.
5. Shake the radiator and lightly tap on the tank ends with a rubber mallet to dislodge trapped debris. Continue flushing until all debris is removed.

CAUTION

Wear appropriate eye and face protection when using compressed air. Flying debris and dirt can cause personal injury.

6. Rinse thoroughly with clean water.

Maintenance

7. Blow compressed air into the radiator in the opposite direction of normal air-flow until the radiator is dry internally.
8. If internal water leakage is suspect, perform a pressure test on the radiator.
9. Reinstall all water supply and drain fittings. Use Teflon™ pipe tape to prevent leaks. Torque the hose clamp screws to the recommended torque value. Refer to the [Cap Screw Markings and Torque Tables](#).
10. Fill the cooling system with the correct mixture of antifreeze and water, and the DCA4 units as outlined earlier in this section.
11. Operate the engine and check for coolant leaks. After the air has been purged from the system, check coolant level again.
12. After completing all service work, start the engine and check for air leaks, loose clamps, and blowby.
13. Inspect the cooling fan for cracks, loose rivets, and bent or loose fan blades.
14. Check that the fan is securely mounted. Tighten all loose cap screws as required.
15. Replace fan guards.

WARNING

Check the coolant level only when the engine is stopped. Wait until the coolant temperature is below 50° C (120° F) before removing the pressure cap. Failure to do so can cause personal injury from heated coolant spray.

Section 6 - Troubleshooting

6.1 Introduction

The following information is intended as a guide for some common non-technical equipment problems. The first part of this section includes troubleshooting charts that cross-reference the problem, the possible cause, and the solution. The second section includes complete Fault Code charts outlining a numerical listing of fault codes and their descriptions.

Many problems can be resolved using corrective maintenance, adjustment, or minor repair. Refer to the vendor supplied literature, electrical schematics, and mechanical prints for additional information.

For engine-related issues, refer to the engine Operation and Maintenance Manual or contact the Cummins Customer Assistance Center at 1-800-CUMMINS™ (1-800-286-6467).

WARNING

*The status checks should be performed **ONLY** by a qualified technician. Contact with exposed electrical components could cause extreme personal injury or death.*

CAUTION

AVOID SERVICING complex components such as: printed circuit boards, programmable controllers, and ECMs not specifically authorized by Cummins. Contact the Cummins Customer Service Department toll free at 1-800-343-7357 before performing any extensive maintenance.

CAUTION

Never climb or stand on the equipment frame, guards, or enclosures. Contact with exposed or moving components can cause personal injury or equipment damage.



Troubleshooting

6.2 Engine Will Not Start

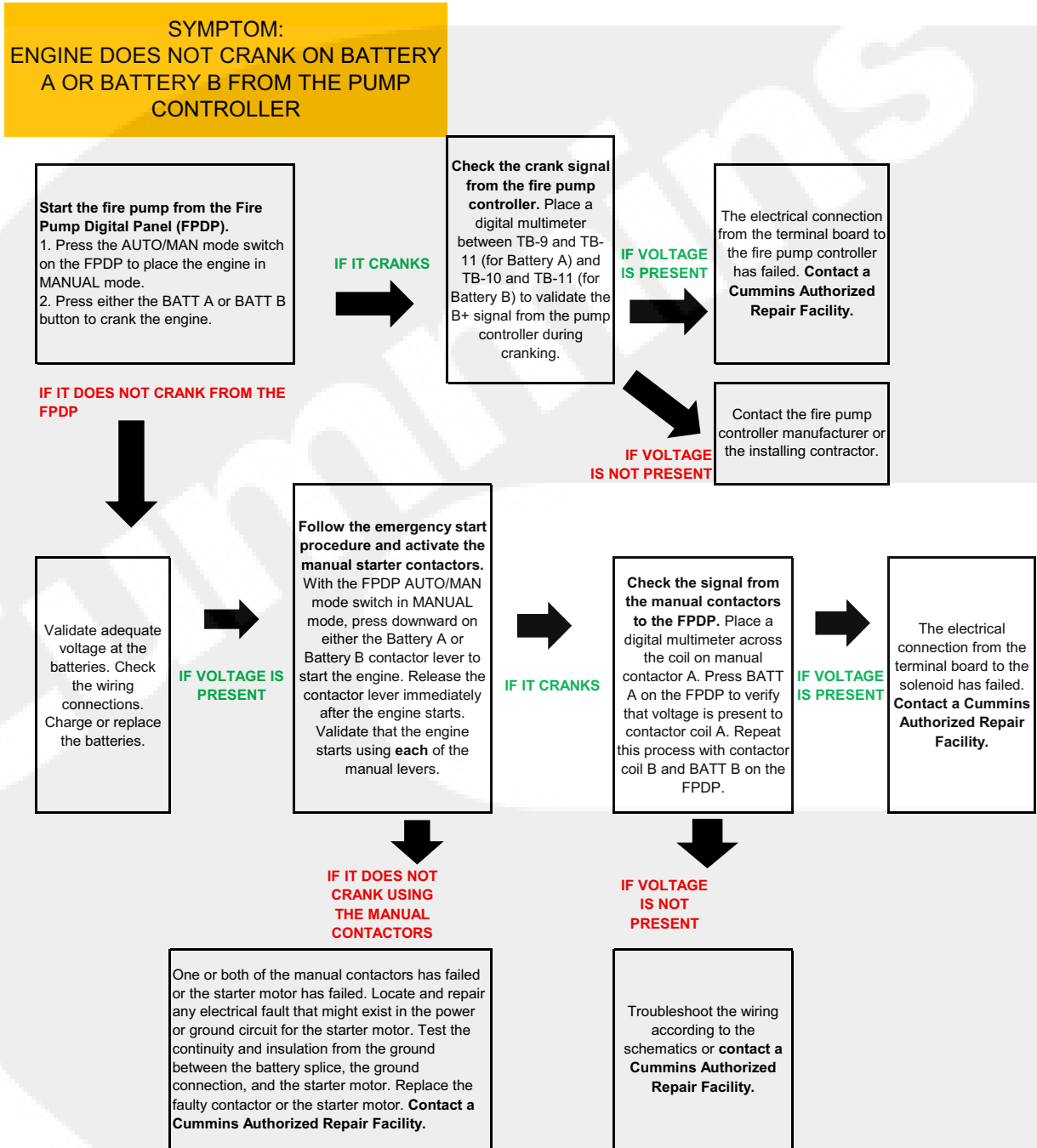

6.3 Engine Cranks But Will Not Start

SYMPTOM:
ENGINE CRANKS FROM THE PUMP CONTROLLER, BUT WILL NOT START (NO EXHAUST SMOKE)

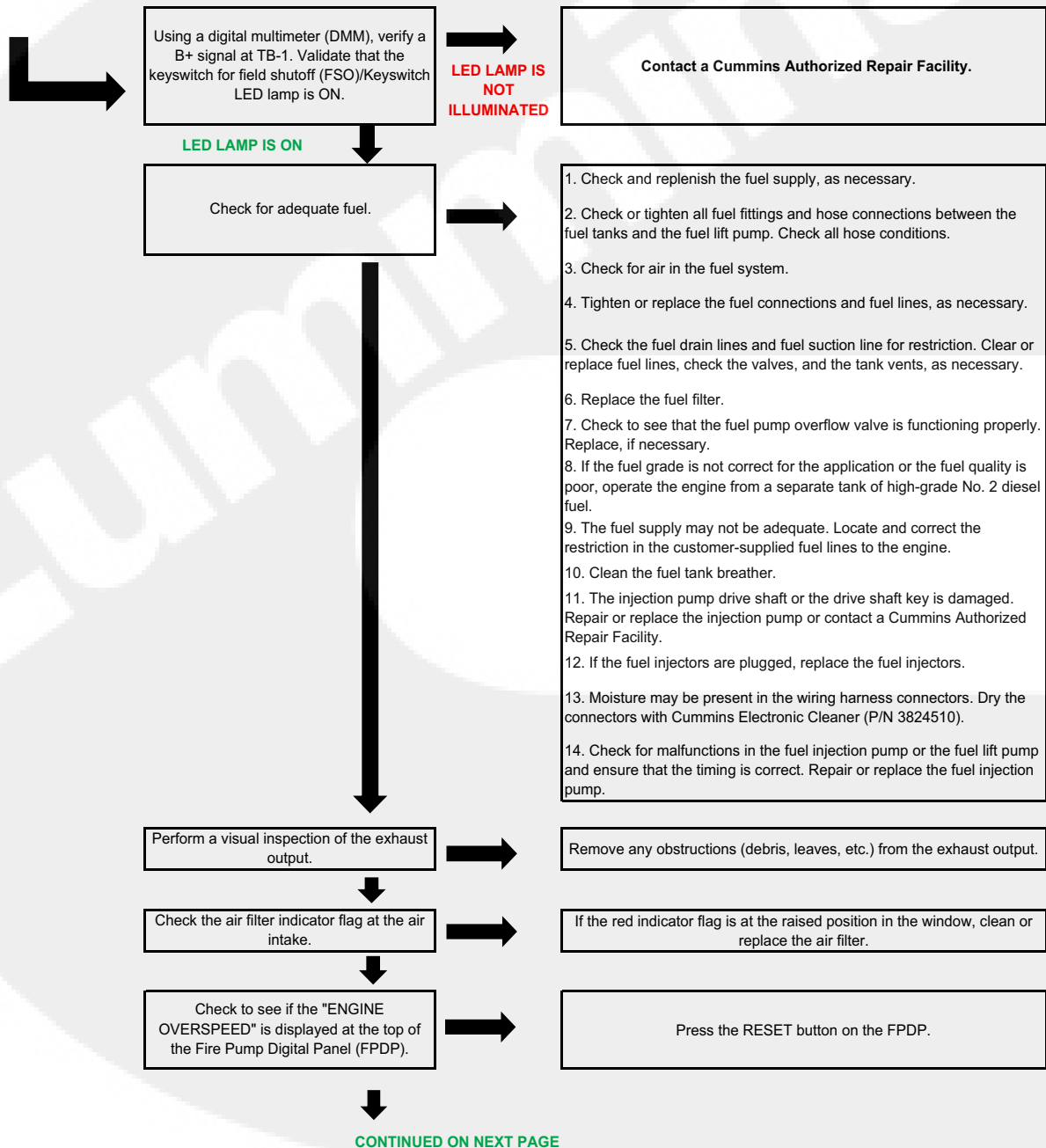

Troubleshooting

Engine Cranks But Will Not Start (cont.)

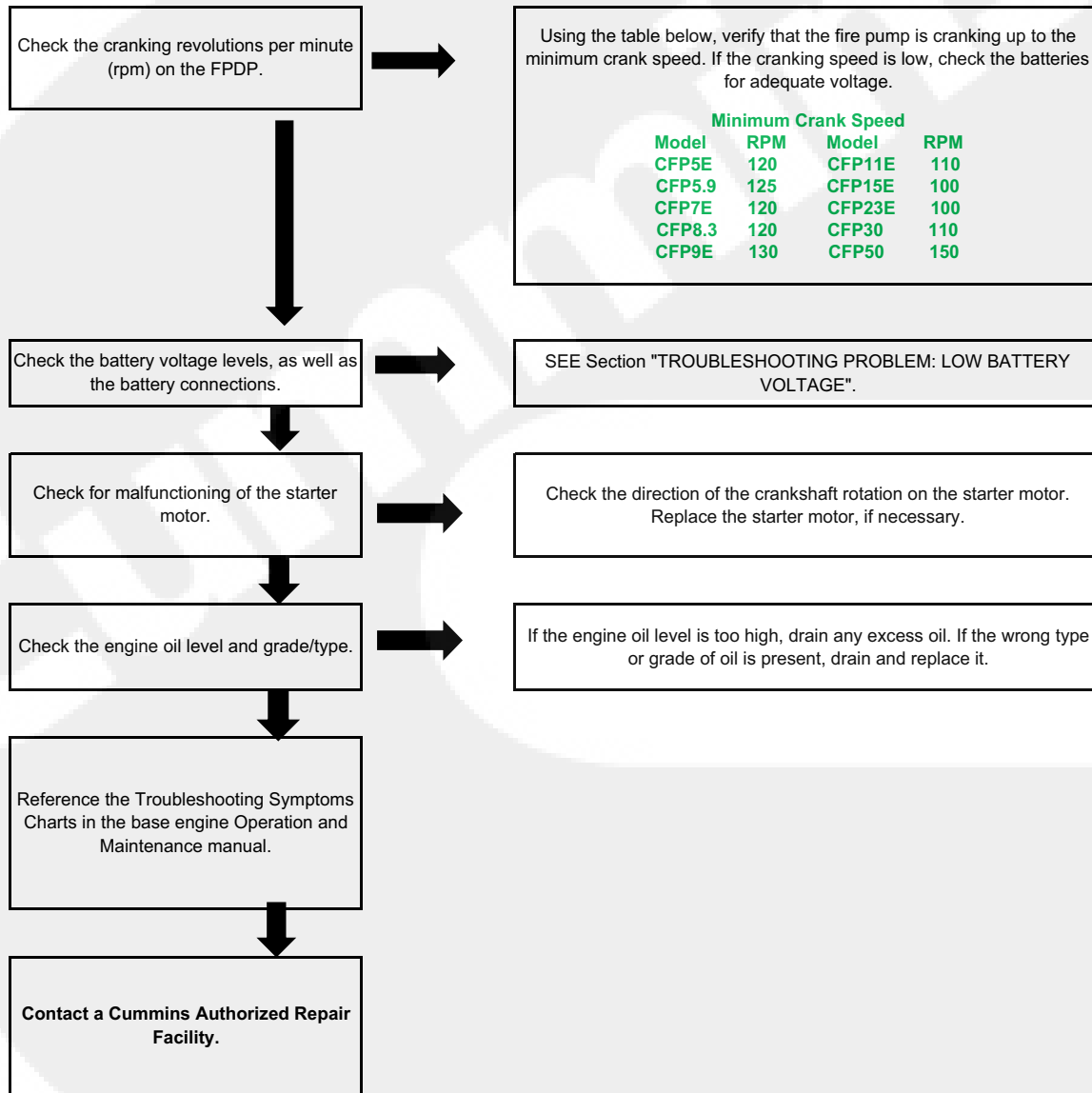

6.4 Engine Starts But Continues to Crank

STOP THE ENGINE AT THE FIRE PUMP CONTROLLER (PLACE THE CONTROLLER IN THE OFF POSITION) AND TROUBLESHOOT FROM THE FIRE PUMP DRIVE ENGINE:

PRIOR TO MAKING A SERVICE CALL, PERFORM A VISUAL INSPECTION:

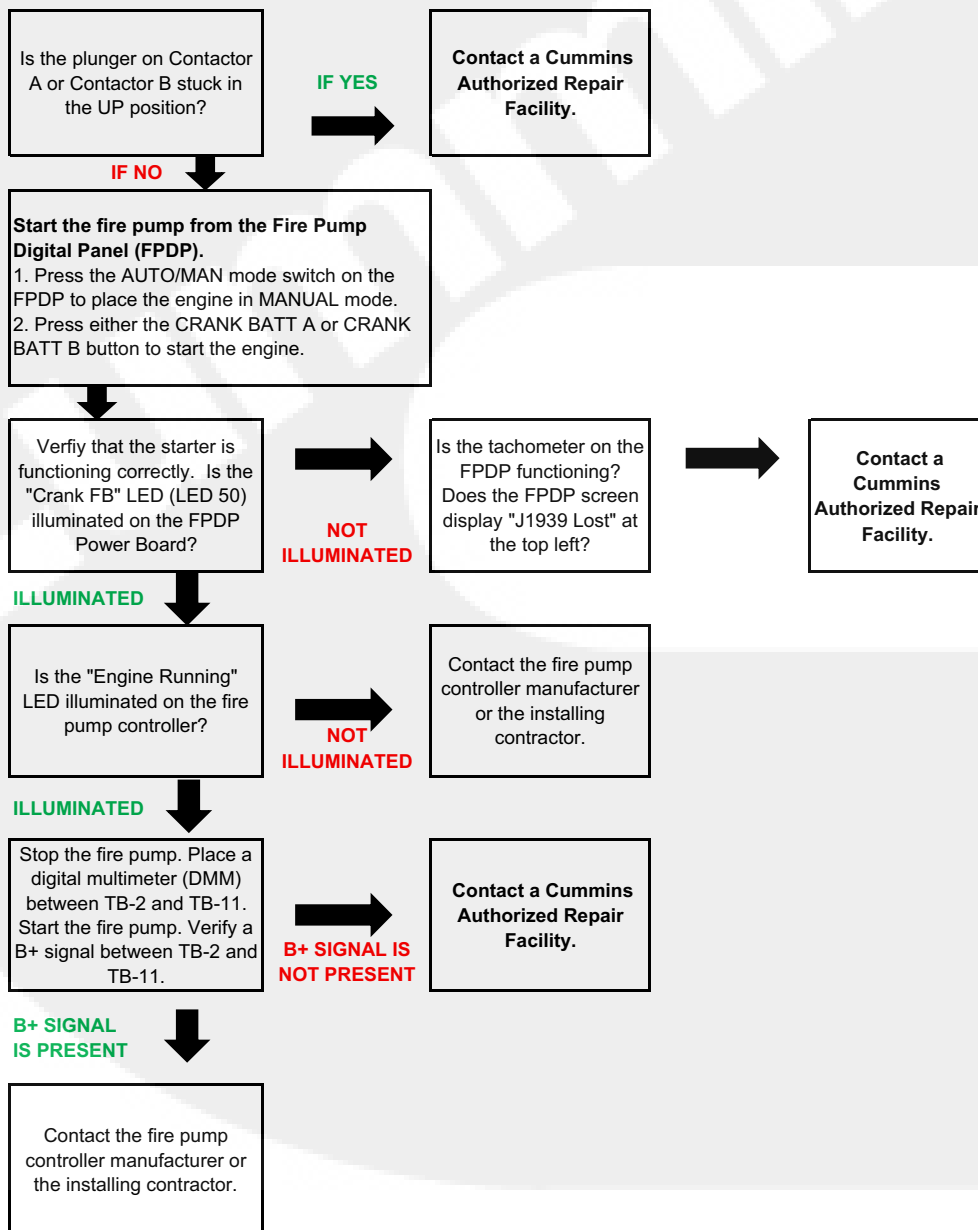

Troubleshooting

6.5 Engine Will Not Stop

TO STOP THE ENGINE:

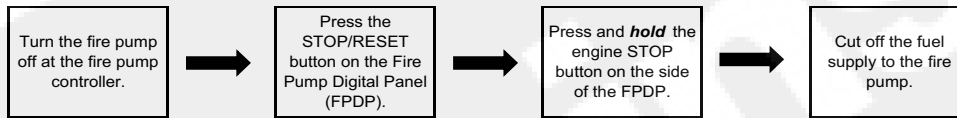

TO TROUBLESHOOT THIS PROBLEM, ONCE THE FIRE PUMP HAS STOPPED:

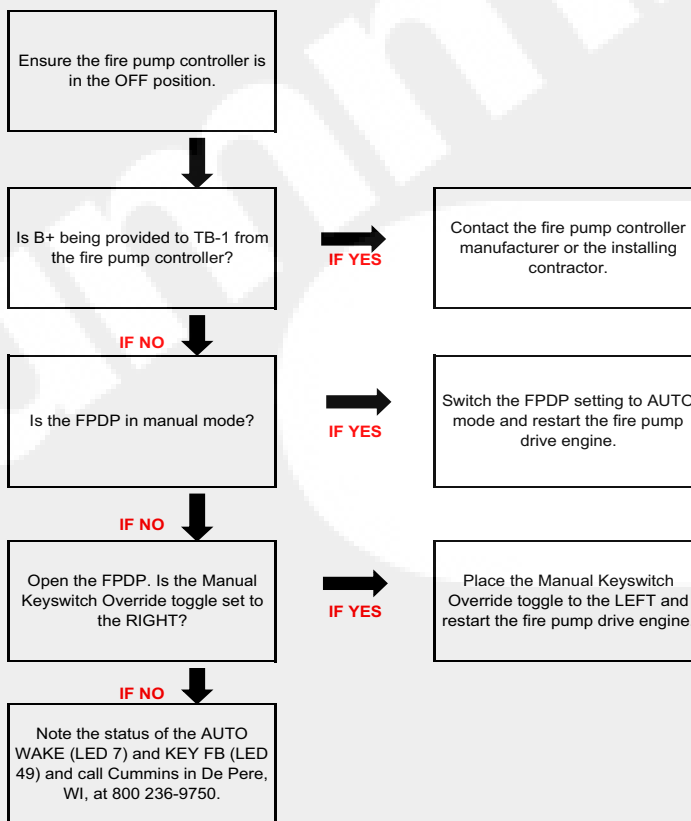

6.6 Low Battery Voltage

PROBLEM: LOW BATTERY VOLTAGE

SYMPTOM: The Fire Pump Digital Panel (FPDP) will momentarily "blink" upon starting or the fire pump drive engine is slow to crank. There is a high probability that the engine will not start.

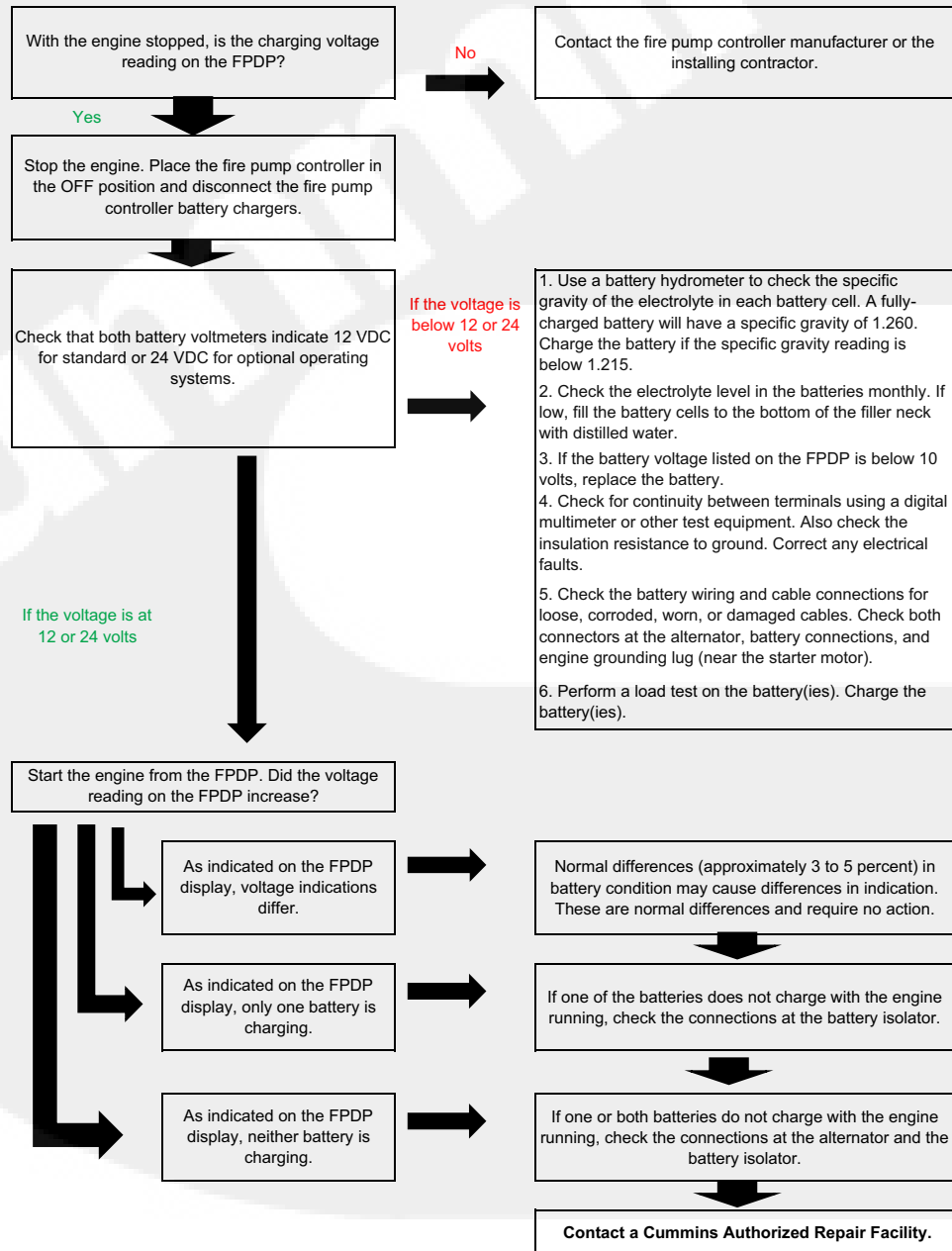

Troubleshooting

6.7 Fault Code Charts - CFP11E, CFP15E/EVS, CFP23E/EVS, CFP30E

The following tables specify the fault codes and their meanings for the CFP11E, CFP15E/EVS, CFP23E/EVS, and CFP30E model fire pump drive engines:



CUMMINS FAULT CODE	SPN	FMI	LAMP COLOR	CUMMINS DESCRIPTION
111	629	12	RED	Engine Control Module - Critical internal failure
112	635	7	RED	Engine Timing Actuator is not responding to ECM commands
113	635	3	YELLOW	Engine Timing Actuator Circuit - shorted high
114	635	4	YELLOW	Engine Timing Actuator Circuit - shorted low
115	190	2	RED	Engine Speed/Position Sensor Circuit - lost both of two signals from the magnetic pickup sensor
116	156	3	RED	Fuel Timing Pressure Sensor Circuit - shorted high
117	156	4	RED	Fuel Timing Pressure Sensor Circuit - shorted low
118	135	3	YELLOW	Fuel Pump Delivery Pressure Sensor Circuit - shorted high
119	135	4	YELLOW	Fuel Pump Delivery Pressure Sensor Circuit - shorted low
121	190	10	YELLOW	Engine Speed/Position Sensor Circuit - lost one of two signals from the magnetic pickup sensor
122	102	3	YELLOW	Intake Manifold Pressure Sensor #1 Circuit - shorted high
123	102	4	YELLOW	Intake Manifold Pressure Sensor #1 Circuit - shorted low
124	102	16	YELLOW	High Intake Manifold Pressure Left Bank
125	102	18		Low Intake Manifold Pressure Left Bank
126	1129	16	YELLOW	High Intake Manifold Pressure Right Bank
127	1129	18		Low Intake Manifold Pressure Left Bank
128	1129	3		Right Bank Intake Manifold Pressure Sensor Circuit Failed High
129	1129	4		Right Bank Intake Manifold Pressure Sensor Circuit Failed Low
131	91	3	RED	Accelerator Pedal Position Sensor Circuit - shorted high
132	91	4	RED	Accelerator Pedal Position Sensor Circuit - shorted low
133	974	3	RED	Remote Accelerator Pedal Position Sensor Circuit - shorted high
133	29	3	RED	Remote Accelerator Pedal Position Sensor Circuit - shorted high
134	974	4	RED	Remote Accelerator Pedal Position Sensor Circuit - shorted low
134	29	4	RED	Remote Accelerator Pedal Position Sensor Circuit - shorted low
135	100	3	YELLOW	Engine Oil Pressure Sensor Circuit - shorted high
136	1208	3		Pre Filter Oil Pressure Sensor Circuit Failed High
137	1208	4		Pre Filter Oil Pressure Sensor Circuit Failed Low
141	100	4	YELLOW	Engine Oil Pressure Sensor Circuit - shorted low
143	100	18	YELLOW	Engine Oil Pressure Low - Warning
143	100	1	RED	Engine Oil Pressure Low - Warning
144	110	3	YELLOW	Engine Coolant Temperature Sensor Circuit - shorted high
145	110	4	YELLOW	Engine Coolant Temperature Sensor Circuit - shorted low

Troubleshooting

CUMMINS FAULT CODE	SPN	FMI	LAMP COLOR	CUMMINS DESCRIPTION
147	91	8	RED	Accelerator Pedal Position Sensor Circuit - low frequency
148	91	8	RED	Accelerator Pedal Position Sensor Circuit - high frequency
151	110	0	RED	Engine Coolant Temperature High - Critical
153	105	3	YELLOW	Intake Manifold Temperature Sensor #1 Circuit - shorted high
154	105	4	YELLOW	Intake Manifold Temperature Sensor #1 Circuit - shorted low
155	105	0	RED	Intake Manifold Temperature #1 High - Critical
166	733	3	YELLOW	Rack Position Sensor #1 Circuit - shorted high
172	638	6	RED	Rack Actuator Position #1 Circuit - grounded circuit
173	638	7	YELLOW	Rack Actuator - mechanically stuck open
184	609	2	YELLOW	Engine Control Module Identification Input State Error
185	639	2	YELLOW	Engine Control Module Network Communication Error
187	620	4	YELLOW	Sensor Supply Voltage #2 Circuit - shorted low
211	1484	31		Additional OEM/Vehicle Diagnostic Codes have been logged.
212	175	3	YELLOW	Engine Oil Temperature Sensor Circuit - shorted high
213	175	4	YELLOW	Engine Oil Temperature Sensor Circuit - shorted low
214	175	0	RED	Engine Oil Temperature High - Critical
221	108	3	YELLOW	Ambient Air Pressure Sensor circuit - shorted high
222	108	4	YELLOW	Ambient Air Pressure Sensor circuit - shorted low
223	1265	4	YELLOW	Engine Oil Burn Valve Solenoid Circuit - shorted low
225	1266	4	YELLOW	Engine Oil Replacement Valve Solenoid Circuit - shorted low
227	620	3	YELLOW	Sensor Supply Voltage #2 Circuit - shorted high
231	109	3	YELLOW	Engine Coolant Pressure Sensor Circuit - shorted high
232	109	4	YELLOW	Engine Coolant Pressure Sensor Circuit - shorted low
233	109	1	RED	Engine Coolant Pressure Low - Warning
233	109	18	YELLOW	Engine Coolant Pressure Low - Warning
234	190	0	RED	Engine Speed High - Critical
235	111	1	RED	Engine Coolant Level Low - Critical
237	644	2	YELLOW	External Speed Input (Multiple Unit Synchronization) - data incorrect
241	84	2	YELLOW	Vehicle Speed Sensor Circuit - data incorrect
242	84	10	YELLOW	Vehicle Speed Sensor Circuit - tampering has been detected
245	647	4	YELLOW	Fan Clutch Circuit - shorted low
254	632	4	RED	Fuel Shutoff Valve Circuit - shorted low
255	632	3	YELLOW	Fuel Shutoff Valve Circuit - shorted high

CUMMINS FAULT CODE	SPN	FMI	LAMP COLOR	CUMMINS DESCRIPTION
259	632	7	RED	Fuel Shutoff Valve - Stuck Open
261	174	0	RED	Fuel Temperature High - Warning
263	174	3	YELLOW	Fuel Temperature Sensor Circuit - shorted high
265	174	4	YELLOW	Fuel Temperature Sensor Circuit - shorted low
284	1043	4	YELLOW	Engine Speed / Position Sensor #1 (Crankshaft) Supply Voltage Circuit - shorted low
285	639	9	YELLOW	SAE J1939 Multiplexing PGN Timeout Error
286	639	13	YELLOW	SAE J1939 Multiplexing Configuration Error
287	91	19	RED	SAE J1939 Multiplexing Accelerator Pedal Sensor System Error
288	974	19	RED	SAE J1939 Multiplexing Remote Throttle Data Error
292	1083	14	RED	Auxiliary Temperature Sensor Input #1 Engine Protection - Critical
293	1083	3	YELLOW	Auxiliary Temperature Sensor Input #1 Circuit - shorted high
294	1083	4	YELLOW	Auxiliary Temperature Sensor Input #1 Circuit - shorted low
295	108	2	YELLOW	Ambient Air Pressure Sensor Circuit - data incorrect
296	1084	14	RED	Auxiliary Pressure Sensor Input #2 Engine Protection - Critical
297	1084	3	YELLOW	Auxiliary Pressure Sensor Input #2 Circuit -shorted high
298	1084	4	YELLOW	Auxiliary Pressure Sensor Input #2 Circuit -shorted low
299	1384	31		Engine Shutdown Commanded by J1939
311	651	6	YELLOW	Injector Solenoid Valve Cylinder #1 Circuit - grounded circuit
312	655	6	YELLOW	Injector Solenoid Valve Cylinder #5 Circuit - grounded circuit
313	653	6	YELLOW	Injector Solenoid Valve Cylinder #3 Circuit - grounded circuit
314	656	6	YELLOW	Injector Solenoid Valve Cylinder #6 Circuit - grounded circuit
315	652	6	YELLOW	Injector Solenoid Valve Cylinder #2 Circuit - grounded circuit
316	931	3	YELLOW	Fuel Supply Pump Actuator Circuit - shorted high
318	931	7	YELLOW	Fuel Supply Pump Actuator - mechanically stuck
319	251	2		Real Time Clock - Power Interrupt
321	654	6	YELLOW	Injector Solenoid Valve Cylinder #4 Circuit - grounded circuit
322	651	5	YELLOW	Injector Solenoid Valve Cylinder #1 Circuit - open circuit
323	655	5	YELLOW	Injector Solenoid Valve Cylinder #5 Circuit - open circuit
324	653	5	YELLOW	Injector Solenoid Valve Cylinder #3 Circuit - open circuit
325	656	5	YELLOW	Injector Solenoid Valve Cylinder #6 Circuit - open circuit
331	652	5	YELLOW	Injector Solenoid Valve Cylinder #2 Circuit - open circuit
332	654	5	YELLOW	Injector Solenoid Valve Cylinder #4 Circuit - open circuit
341	630	2	YELLOW	Engine Control Module - data lost

Troubleshooting

CUMMINS FAULT CODE	SPN	FMI	LAMP COLOR	CUMMINS DESCRIPTION
342	630	13	RED	Engine Control Module - Out of Calibration
343	629	12	YELLOW	Engine Control Module - Warning Internal Hardware Failure
346	630	12	YELLOW	Engine Control Module - Warning Software error
349	191	16	YELLOW	Transmission Output Shaft (Tailshaft) Speed High - Warning
349	191	0	YELLOW	Transmission Output Shaft (Tailshaft) Speed High - Warning
352	1079	4	YELLOW	Sensor Supply Voltage #1 Circuit - shorted low
378	633	5	YELLOW	Fueling Actuator #1 Circuit - Open Circuit
379	633	6	YELLOW	Fueling Actuator #1 Circuit - Grounded Circuit
384	626	11	YELLOW	Start Assist Device Control Circuit Error (Ether Injection)
386	1079	3	YELLOW	Sensor Supply Voltage #1 Circuit - shorted high
387	1043	3	YELLOW	Accelerator Pedal Position Sensor Supply Voltage Circuit - shorted high
394	635	5	YELLOW	Timing Actuator #1 Circuit - Open Circuit
395	635	6	YELLOW	Timing Actuator #1 Circuit - grounded circuit
396	1244	5	YELLOW	Fueling Actuator #2 Circuit - open circuit
397	1244	6	YELLOW	Fueling Actuator #2 Circuit - grounded circuit
398	1245	5	YELLOW	Timing Actuator #2 Circuit - open circuit
399	1245	6	YELLOW	Timing Actuator #2 Circuit - Grounded Circuit
414	608	9	YELLOW	Data Communication error over the J1587 data link circuit
415	100	1	RED	Engine Oil Pressure Low - Critical
418	97	15		Water in Fuel Indicator High - Maintenance
419	1319	2	YELLOW	Intake Manifold Boost Pressure Imbalance
422	111	2	YELLOW	Engine Coolant Level Sensor Circuit - data incorrect
423	156	2	YELLOW	Fuel Timing Pressure or Timing Actuator stuck
426	639	2		SAE J1939 datalink - cannot transmit
427	639	9		SAE J1939 not fast enough
428	97	3	YELLOW	Water in Fuel Sensor Circuit - shorted high
429	97	4	YELLOW	Water in Fuel Sensor Circuit - shorted low
431	558	2	YELLOW	Accelerator Pedal Idle Validation Circuit - data incorrect
431	91	2	YELLOW	Accelerator Pedal Idle Validation Circuit - data incorrect
432	558	13	RED	Accelerator Pedal Idle Validation Circuit - Our of Calibration
432	91	13	RED	Accelerator Pedal Idle Validation Circuit - Our of Calibration
433	102	2	YELLOW	Intake Manifold Pressure Sensor Circuit - data incorrect
434	627	2	YELLOW	Power Lost without Ignition Off

CUMMINS FAULT CODE	SPN	FMI	LAMP COLOR	CUMMINS DESCRIPTION
435	100	2	YELLOW	Engine Oil Pressure Sensor Circuit - data incorrect
441	168	18	YELLOW	Battery #1 Voltage Low - Warning
441	168	1		Battery #1 Voltage Low - Warning
442	168	16	YELLOW	Battery #1 Voltage High- Warning
443	1043	4	YELLOW	Accelerator Pedal Position Sensor Supply Voltage Circuit - shorted low
449	94	16	YELLOW	Fuel Pressure High - Warning
451	157	3	YELLOW	Injector Metering Rail #1 Pressure Sensor Circuit - Shorted High
452	157	4	YELLOW	Injector Metering Rail #1 Pressure Sensor Circuit - Shorted Low
455	633	3	RED	Fuel Control Valve Circuit - shorted high
466	1188	4	YELLOW	Turbocharger #1 Wastegate Control Circuit - shorted low
467	635	2	YELLOW	Timing Rail Actuator Circuit - data incorrect
468	633	2	YELLOW	Fuel Rail Actuator Circuit - data incorrect
479	1318	9		Exhaust Port Temperature Bank Imbalance
482	94	18	YELLOW	Fuel Pressure Low - Warning
483	1349	3	YELLOW	Injector Metering Rail #2 Pressure Sensor Circuit - Shorted High
484	1349	4	YELLOW	Injector Metering Rail #2 Pressure Sensor Circuit - Shorted Low
485	1349	16	YELLOW	Injector Metering Rail #2 Pressure High - Warning
486	1349	18	YELLOW	Injector Metering Rail #2 Pressure Low - Warning
487	626	1		Start Assist Device - Canister Empty (Ether Injection)
489	191	18	YELLOW	Transmission Output Shaft (Tailshaft) Speed Low - Warning
489	191	1	YELLOW	Transmission Output Shaft (Tailshaft) Speed Low - Warning
496	1043	11	YELLOW	Engine Speed/Position Sensor #2 (Camshaft) Supply Voltage
497	1377	2	YELLOW	Multiple Unit Synchronization Switch Circuit - data incorrect
514	633	7	RED	Fuel Control Valve - mechanically stuck
524	113	2	YELLOW	OEM Alternate Droop Switch Validation - data incorrect
527	702	3	YELLOW	Auxiliary Input/Output #2 Circuit - shorted high
528	93	2	YELLOW	OEM Alternate torque validation switch - data incorrect
529	703	3	YELLOW	Auxiliary Input/Output #3 Circuit - shorted high
546	94	3	YELLOW	Fuel Delivery Pressure Sensor Circuit - shorted high
547	94	4	YELLOW	Fuel Delivery Pressure Sensor Circuit - shorted low
551	558	4	YELLOW	Accelerator Pedal Idle Validation Circuit - shorted low
551	91	4	RED	Accelerator Pedal Idle Validation Circuit - shorted low
553	157	16	YELLOW	Injector Metering Rail #1 Pressure High - Warning Level

Troubleshooting

CUMMINS FAULT CODE	SPN	FMI	LAMP COLOR	CUMMINS DESCRIPTION
554	157	2	YELLOW	Fuel Pressure Sensor Error
555	1264	16	YELLOW	Engine Blowby - Warning Level
555	1264	0	RED	Engine Blowby - Warning Level
581	1381	3	YELLOW	Fuel Supply Pump Inlet Pressure Sensor Circuit - shorted high
582	1381	4	YELLOW	Fuel Supply Pump Inlet Pressure Sensor Circuit - shorted low
583	1381	18	YELLOW	Fuel Supply Pump Inlet Pressure Low - warning level
595	103	16	YELLOW	Turbocharger #1 Speed High - warning level
596	167	16	YELLOW	Electrical Charging System Voltage High - warning level
597	167	18	YELLOW	Electrical Charging System Voltage Low - warning level
598	167	1	RED	Electrical Charging System Voltage Low - critical level
611	1383	31		Engine Hot Shutdown
612	99	1	RED	High Lubricating Oil Filter Restriction
617	1172	0		High Turbo Compressor Inlet Temperature LB
621	1137	18	YELLOW	Low #1 LB Cylinder Power
622	1138	18	YELLOW	Low #2 LB Cylinder Power
623	1139	18	YELLOW	Low #3 LB Cylinder Power
624	1140	18	YELLOW	Low #4 LB Cylinder Power
625	1141	18	YELLOW	Low #5 LB Cylinder Power
626	1142	18	YELLOW	Low #6 LB Cylinder Power
631	1329	1	YELLOW	Low #1 RB Cylinder Power
632	1329	1	YELLOW	Low #2 RB Cylinder Power
633	1329	1	YELLOW	Low #3 RB Cylinder Power
634	1329	1	YELLOW	Low #4 RB Cylinder Power
635	1329	1	YELLOW	Low #5 RB Cylinder Power
636	1329	1	YELLOW	Low #6 RB Cylinder Power
641	1137	0	RED	High #1 LB Cylinder Exhaust Temperature
642	1138	0	RED	High #2 LB Cylinder Exhaust Temperature
643	1139	0	RED	High #3 LB Cylinder Exhaust Temperature
644	1140	0	RED	High #4 LB Cylinder Exhaust Temperature
645	1141	0	RED	High #5 LB Cylinder Exhaust Temperature
646	1142	0	RED	High #6 LB Cylinder Exhaust Temperature
649	1378	0		Change Lubricating Oil and Filter

CUMMINS FAULT CODE	SPN	FMI	LAMP COLOR	CUMMINS DESCRIPTION
651	1143	0	RED	High #1 RB Cylinder Exhaust Temperature
	1145	0	RED	
652	1144	0	RED	High #2 RB Cylinder Exhaust Temperature
	1146	0	RED	
653	1145	0	RED	High #3 RB Cylinder Exhaust Temperature
	1147	0	RED	
654	1146	0	RED	High #4 RB Cylinder Exhaust Temperature
	1148	0	RED	
655	1147	0	RED	High #5 RB Cylinder Exhaust Temperature
	1149	0	RED	
656	1148	0	RED	High #6 RB Cylinder Exhaust Temperature
	1149	0	RED	
661	1323	0	YELLOW	High #1 LB Cylinder Power
662	1324	0	YELLOW	High #2 LB Cylinder Power
663	1325	0	YELLOW	High #3 LB Cylinder Power
664	1326	0	YELLOW	High #4 LB Cylinder Power
665	1327	0	YELLOW	High #5 LB Cylinder Power
666	1328	0	YELLOW	High #6 LB Cylinder Power
671	1137	4		Cylinder #1 LB Exhaust Temperature Sensor Failed Low
672	1138	4		Cylinder #2 LB Exhaust Temperature Sensor Failed Low
673	1139	4		Cylinder #3 LB Exhaust Temperature Sensor Failed Low
674	1140	4		Cylinder #4 LB Exhaust Temperature Sensor Failed Low
675	1141	4		Cylinder #5 LB Exhaust Temperature Sensor Failed Low
676	1142	4		Cylinder #6 LB Exhaust Temperature Sensor Failed Low
691	1172	3		LBF Turbo Comp Inlet Temperature Sensor Failed High
692	1172	4		LBF Turbo Comp Inlet Temperature Sensor Failed Low
711	1329	0	YELLOW	High #1 RB Cylinder Power
712	1330	0	YELLOW	High #2 RB Cylinder Power
713	1331	0	YELLOW	High #3 RB Cylinder Power
714	1332	0	YELLOW	High #4 RB Cylinder Power
715	1333	0	YELLOW	High #5 RB Cylinder Power
716	1334	0	YELLOW	High #6 RB Cylinder Power
719	1264	3	YELLOW	Crankcase Blowby Pressure Sensor Circuit - shorted high

Troubleshooting

CUMMINS FAULT CODE	SPN	FMI	LAMP COLOR	CUMMINS DESCRIPTION
721	1143	4		Cylinder #1 RB Exhaust Temperature Sensor Failed Low
	1145	4		
722	1144	4		Cylinder #2 RB Exhaust Temperature Sensor Failed Low
	1146	4		
723	1145	4		Cylinder #3 RB Exhaust Temperature Sensor Failed Low
	1147	4		
724	1146	4		Cylinder #4 RB Exhaust Temperature Sensor Failed Low
	1148	4		
725	1147	4		Cylinder #5 RB Exhaust Temperature Sensor Failed Low
	1149	4		
726	1148	4		Cylinder #6 RB Exhaust Temperature Sensor Failed Low
	1149	4		
729	1264	4	YELLOW	Crankcase Blowby Pressure Sensor Circuit - shorted low
753	723	2		Engine Speed/Position #2 - Cam sync error
758	1349	7	YELLOW	Injector Metering Rail #2 Pressure Malfunction
951	166	2		Cylinder Power Imbalance between cylinders
2155	611	4		Post-Filter Oil Pressure Sensor Circuit - shorted low





Section 7 - Component Parts and Assemblies

7.1 Ordering Parts

Replacement parts for the Cummins Inc. equipment are manufactured to the same quality standards and specifications as the original equipment. Unapproved substitution may result in poor performance, reduced service life, lost production, or unsafe operation.

Cummins Inc. relies on the best and most cost effective shipping methods, unless specific instructions or requirements are requested by the customer. When ordering parts, please be prepared to provide the following information.

- Model and serial number.
- Part description by name or number.
- Quantity required.
- Purchase order number.

NOTE: *A purchase order number is desirable, even if the part(s) are supplied on a Returned Goods Authorization (RGA) issue number. A purchase order number helps Cummins and its customer track the parts and necessary credits.*

7.2 Repairs and Technical Service

Personnel at Cummins Authorized Repair Locations can assist you with the correct operation and service of your engine. Cummins has a worldwide service network of more than 5,000 Distributors and Dealers who have been trained to provide sound advice, expert service, and complete parts support.

Check the telephone directory yellow pages or refer to the directory in this section for the nearest Cummins Authorized Repair Location.

The Cummins Customer Assistance Center provides a 24-hour, toll free telephone number to aid in technical and emergency service when a Cummins Authorized Repair Location cannot be reached or is unable to resolve an issue with a Cummins product.

If assistance is required, call Toll-Free: 1-800-DIESELS (1-800-343-7357). Includes all 50 states, Bermuda, Puerto Rico, Virgin Islands, and the Bahamas.

Outside of North America contact your Regional Office. Telephone numbers and addresses are listed in the International Directory.

Refer also to the Cummins Inc. web site at www.cummins.com.

7.3 Recommended Spare Parts Inventory

To minimize downtime and increase productivity, Cummins Inc. recommends maintaining a stock of spare parts critical to uninterrupted engine operation. Shipping costs can be lower using ground transportation rather than overnight or next day air freight. For this reason, Cummins Inc. can provide a list of recommended spare parts. Contact a Cummins Authorized Repair Location for additional information.

7.4 Engine Data Sheet and Torque Values

The following pages outline applicable reference material for the CFP23E fire pump drive engine. [Table 7-1.](#) represents the engine data for the CFP23E and all its ratings at the time of this printing. For a complete, up-to-date, Model Specification Sheet, refer to www.cumminsfirepower.com. [Table 7-2. Cap Screw Markings and Torque Tables](#) outlines the recommended cap screw markings and torque values for fire pump drive engines.



Component Parts and Assemblies

Table 7-1. CFP23E Engine Data

Air Induction System - F15-F35

Maximum Temperature Rise Between Ambient Air and Engine Air Inlet	30 °F (16.7 °C)
Maximum Inlet Restriction with Dirty Filter	25 in. H ₂ O (635 mm H ₂ O)
Recommended Air Cleaner Element - (Standard) Cummins Filtration	(1) primary element AF25544; (1) secondary element AF25545

Lubrication System - F15-F35

Oil Pressure Range at Rated	50-65 PSI (345-448 kPa)
Oil Capacity of Pan (High - Low)	15-12 qt. (56-46 L)
Total System Capacity	16.1 gal. (61 L)
Recommended Lube Oil Filter	(2) Cummins Filtration LF9325

Cooling System - F15-F35*

Raw Water Working Pressure Range at Heat Exchanger	60 PSI (413 kPa) MAX
Recommended Minimum Water Supply Pipe Size to Heat Exchanger	1.25 in. (31.75 mm)
Recommended Minimum Water Discharge Pipe Size From Heat Exchanger	1.50 in. (38.10 mm)
Coolant Water Capacity (Engine Only)	17.3 gal. (65.5 L)
Standard Thermostat - Type	Modulating
Standard Thermostat - Range	170-194 °F (76.5-90 °C)
Normal Operating Temperature	180-212 °F (82-100 °C)
Minimum Raw Water Flow:	
- with Water Temperatures to 60 °F (16 °C)	28 GPM (1.77 L/sec)
- with Water Temperatures to 80 °F (27 °C)	33 GPM (2.08 L/sec)
- with Water Temperatures to 100 °F (38 °C)	38 GPM (2.40 L/sec)
Recommended Cooling Water Filter	(1) Cummins Filtration WF2076

* A jacket water heater is mandatory on this engine. The recommended heater wattage is 3000 down to 40 °F (4 °C)

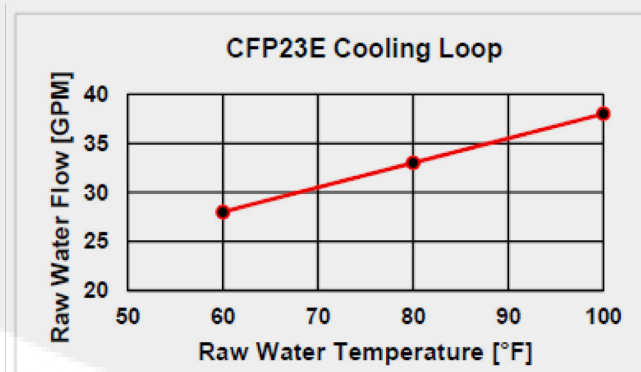

Exhaust System - F15-F35

Maximum Allowable Back Pressure by Complete Exhaust System	40.8 in. H ₂ O (10.2 kPa)
Exhaust Pipe Size Normally Acceptable	8 in. (203 mm)

Table 7-1. CFP23E Engine Data (Cont'd.)

Air Induction System - F10-F70

Maximum Temperature Rise Between Ambient Air and Engine Air Inlet	63 °F (35 °C)
Maximum Inlet Restriction with Dirty Filter	25 in. H ₂ O (635 mm H ₂ O)
Recommended Air Cleaner Element - (Standard) Cummins Filtration	(1) primary element AF25544; (1) secondary element AF25545

Lubrication System - F10-F70

Oil Pressure Range at Rated	50-65 PSI (345-448 kPa)
Oil Capacity of Pan (High - Low)	15-12 qt. (56-46 L)
Total System Capacity	16.1 gal. (61 L)
Recommended Lube Oil Filter	(2) Cummins Filtration LF9325

Cooling System - F10-F70*

Raw Water Working Pressure Range at Heat Exchanger	60 PSI (413 kPa) MAX
Recommended Minimum Water Supply Pipe Size to Heat Exchanger	1.25 in. (31.75 mm)
Recommended Minimum Water Discharge Pipe Size From Heat Exchanger	1.50 in. (38.10 mm)
Coolant Water Capacity (Engine Only)	17.3 gal. (65.5 L)
Standard Thermostat - Type	Modulating
Standard Thermostat - Range	170-194 °F (76.5-90 °C)
Normal Operating Temperature	180-212 °F (82-100 °C)
Minimum Raw Water Flow:	
- with Water Temperatures to 60 °F (16 °C)	28 GPM (1.77 L/sec)
- with Water Temperatures to 80 °F (27 °C)	33 GPM (2.08 L/sec)
- with Water Temperatures to 100 °F (38 °C)	38 GPM (2.40 L/sec)
Recommended Cooling Water Filter	(1) Cummins Filtration WF2076

* A jacket water heater is mandatory on this engine. The recommended heater wattage is 3000 down to 40 °F (4 °C)

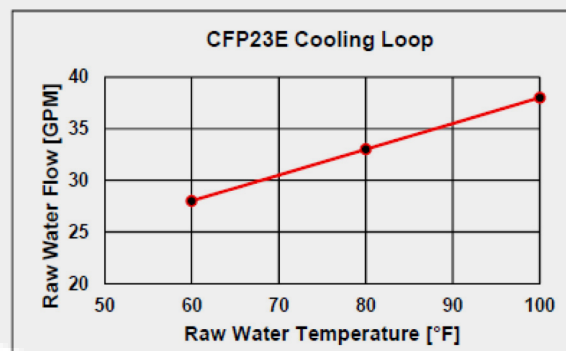

Exhaust System - F10-F70

Maximum Allowable Back Pressure by Complete Exhaust System	40.8 in. H ₂ O (10.2 kPa)
Exhaust Pipe Size Normally Acceptable	8 in. (203 mm)

Component Parts and Assemblies

Table 7-1. CFP23E Engine Data (Cont'd.)

Noise Emissions - The noise emission values are estimated sound pressure levels at 3.3 ft. (1 m).

Top	104.4 dBa
Right Side	105.0 dBa
Left Side	105.0 dBa
Front	103.0 dBa
Exhaust	121.0 dBa

Fuel Supply/Drain System

Operating Speed in RPM	1470		1760		1900		2100	
	CFP23E F-10 Fuel Rate - Gal/hr (L/hr)	28.7	(108.5)	32.6	(123.6)			
CFP23E/EVS F-15 Fuel Rate - Gal/hr (L/hr)	30.2	(114)	33.9	(128)	34.6	(131)	36.3	(138)
CFP23E F-20 Fuel Rate - Gal/hr (L/hr)	31.0	(117.3)	35.2	(133.3)				
CFP23E/EVS F-25 Fuel Rate - Gal/hr (L/hr)	31.0	(117)	34.8	(132)	35.5	(135)	37.3	(141)
CFP23E F-30 Fuel Rate - Gal/hr (L/hr)	32.9	(124.7)	37.5	(141.8)				
CFP23E/EVS F-35 Fuel Rate - Gal/hr (L/hr)	31.8	(120)	35.7	(135)	36.5	(138)	38.2	(145)
CFP23E F-40 Fuel Rate - Gal/hr (L/hr)	34.0	(128.6)	39.7	(150.5)				
CFP23E F-50 Fuel Rate - Gal/hr (L/hr)	34.2	(129.5)	43.3	(163.7)				
CFP23E F-36 Fuel Rate - Gal/hr (L/hr)	37.2	(140.7)	46.8	(177.0)				
CFP23E F-70 Fuel Rate - Gal/hr (L/hr)	38.8	(146.7)	50.3	(190.3)				

Fuel Type	No. 2 diesel only
Minimum Supply Line Size	1 in. (25.40 mm)
Minimum Drain Line Size	1 in. (25.40 mm)
Maximum Fuel Line Length Between Supply Tank & Fuel Pump	40 ft. (12 m)
Maximum Fuel Height above C/L Fuel Pump	96 in. (2.4 m)
Recommended Fuel Filter - Primary	(2) Cummins Filtration FS1006
Recommended Fuel Filter - Secondary	None
Maximum Restriction @ Lift Pump-Inlet - With Clean Filter	4.0 in. Hg (102 mm Hg)
Maximum Restriction @ Lift Pump-Inlet - With Dirty Filter	8.0 in. Hg (203 mm Hg)
Maximum Return Line Restriction - Without Check Valves	9 in. Hg (229 mm Hg)
Minimum Fuel Tank Vent Capability	100 ft ³ /hr (3 m ³ /hr)
Maximum Fuel Temperature @ Lift Pump Inlet	160 °F (71 °C)

Starting and Electrical System

Min. Recommended Battery Capacity - Cold Soak at 0 °F (-18 °C) or Above	24V
Engine Only - Cold Cranking Amperes	1400 CCA*
Engine Only - Reserve Capacity	460 minutes*

*Based on FM requirement for a minimum of 900 CCA and 430 Reserve Capacity Minutes

Battery Cable Size - Minimum of 2/0 AWG and Maximum Cable Length Not to Exceed 6 ft. (1.5 m)	24V
Maximum Resistance of Starting Circuit	0.002 Ohms
Typical Cranking Speed	120 RPM
Alternator (Standard), Internally Regulated	35 amps



Operating Conditions

Operating Speed in RPM	1470		1760		1900		2100	
CFP23E F-10								
Output - BHP (kW)	630	(470)	698	(520)				
Ventilation Air Required - CFM (litre/sec)	936	(442)	1203	(568)				
Exhaust Gas Flow - CFM (litre/sec)	2605	(1,230)	2842	(1,341)				
Exhaust Gas Temperature - °F (°C)	539	(282)	474	(245)				
Heat Rejection to Coolant - BTU/min. (kW)	6670	(117)	7668	(135)				
Heat Rejection to Ambient - BTU/min. (kW)	2004	(35)	2605	(46)				
CFP23E/EVS F-15								
Output - BHP (kW)	630	(470)	698	(520)	722	(538)	751	(560)
Ventilation Air Required - CFM (litre/sec)	1316	(621)	1581	(746)	1709	(807)	1892	(893)
Exhaust Gas Flow - CFM (litre/sec)	3626	(1711)	4103	(1937)	4334	(2045)	4663	(2201)
Exhaust Gas Temperature - °F (°C)	904	(485)	847	(453)	819	(437)	779	(415)
Heat Rejection to Coolant - BTU/min. (kW)	8288	(146)	9265	(163)	9736	(171)	10410	(183)
Heat Rejection to Ambient - BTU/min. (kW)	3463	(61)	3833	(67)	4012	(71)	4267	(75)
CFP23E F-20								
Output - BHP (kW)	676	(508)	753	(562)				
Ventilation Air Required - CFM (litre/sec)	1084	(512)	1393	(657)				
Exhaust Gas Flow - CFM (litre/sec)	3106	(1,466)	3289	(1,553)				
Exhaust Gas Temperature - °F (°C)	624	(329)	548	(287)				
Heat Rejection to Coolant - BTU/min. (kW)	7721	(136)	8876	(156)				
Heat Rejection to Ambient - BTU/min. (kW)	2320	(41)	3015	(53)				
CFP23E/EVS F-25								
Output - BHP (kW)	676	(504)	755	(563)	774	(577)	801	(597)
Ventilation Air Required - CFM (litre/sec)	1316	(621)	1581	(746)	1709	(807)	1892	(893)
Exhaust Gas Flow - CFM (litre/sec)	3626	(1711)	4103	(1937)	4334	(2045)	4663	(2201)
Exhaust Gas Temperature - °F (°C)	904	(485)	847	(453)	819	(437)	779	(415)
Heat Rejection to Coolant - BTU/min. (kW)	8288	(146)	9265	(163)	9736	(171)	10410	(183)
Heat Rejection to Ambient - BTU/min. (kW)	3463	(61)	3833	(67)	4012	(71)	4267	(75)
CFP23E F-30								
Output - BHP (kW)	724	(540)	801	(597)				
Ventilation Air Required - CFM (litre/sec)	1204	(568)	1547	(730)				
Exhaust Gas Flow - CFM (litre/sec)	3351	(1,582)	3655	(1,725)				
Exhaust Gas Temperature - °F (°C)	693	(367)	609	(321)				
Heat Rejection to Coolant - BTU/min. (kW)	8579	(151)	9862	(173)				
Heat Rejection to Ambient - BTU/min. (kW)	2578	(45)	3351	(59)				

Component Parts and Assemblies

CFP23E/EVS F-35								
Output - BHP (kW)	700	(522)	770	(574)	798	(595)	840	(626)
Ventilation Air Required - CFM (litre/sec)	1316	(621)	1581	(746)	1709	(807)	1892	(893)
Exhaust Gas Flow - CFM (litre/sec)	3626	(1711)	4103	(1937)	4334	(2045)	4663	(2201)
Exhaust Gas Temperature - °F (°C)	904	(485)	847	(453)	819	(437)	779	(415)
Heat Rejection to Coolant - BTU/min. (kW)	8288	(146)	9265	(163)	9736	(171)	10410	(183)
Heat Rejection to Ambient - BTU/min. (kW)	3463	(61)	3833	(67)	4012	(71)	4267	(75)
CFP23E F-40								
Output - BHP (kW)	747	(557)	850	(634)				
Ventilation Air Required - CFM (litre/sec)	1327	(626)	1705	(805)				
Exhaust Gas Flow - CFM (litre/sec)	3692	(1,743)	4026	(1,900)				
Exhaust Gas Temperature - °F (°C)	764	(407)	671	(355)				
Heat Rejection to Coolant - BTU/min. (kW)	9451	(166)	10864	(191)				
Heat Rejection to Ambient - BTU/min. (kW)	2840	(50)	3691	(65)				
CFP23E F-50								
Output - BHP (kW)	752	(560)	925	(690)				
Ventilation Air Required - CFM (litre/sec)	1475	(696)	1895	(894)				
Exhaust Gas Flow - CFM (litre/sec)	4104	(1,937)	4476	(2,113)				
Exhaust Gas Temperature - °F (°C)	849	(454)	746	(397)				
Heat Rejection to Coolant - BTU/min. (kW)	10506	(185)	12078	(212)				
Heat Rejection to Ambient - BTU/min. (kW)	3157	(55)	4103	(72)				
CFP23E F-60								
Output - BHP (kW)	817	(609)	1000	(746)				
Ventilation Air Required - CFM (litre/sec)	1600	(755)	2056	(970)				
Exhaust Gas Flow - CFM (litre/sec)	4452	(2,101)	4856	(2,292)				
Exhaust Gas Temperature - °F (°C)	921	(494)	809	(432)				
Heat Rejection to Coolant - BTU/min. (kW)	11397	(200)	13102	(230)				
Heat Rejection to Ambient - BTU/min. (kW)	3425	(60)	4451	(78)				
CFP23E F-70								
Output - BHP (kW)	852	(635)	1075	(802)				
Ventilation Air Required - CFM (litre/sec)	1720	(812)	2210	(1,043)				
Exhaust Gas Flow - CFM (litre/sec)	4786	(2,259)	5220	(2,464)				
Exhaust Gas Temperature - °F (°C)	990	(532)	870	(466)				
Heat Rejection to Coolant - BTU/min. (kW)	12252	(215)	14085	(248)				
Heat Rejection to Ambient - BTU/min. (kW)	3682	(65)	4785	(84)				



Table 7-2. Cap Screw Markings and Torque Tables

Cap Screw Markings and Torque Values



Always use a cap screw of the same measurement and strength as the cap screw being replaced. Using the wrong cap screws can result in engine damage.

Always use the torque values listed in the following tables when specific torque values are not available.

When the ft-lb value is less than 10, convert the ft-lb value to in-lb to obtain a better torque with an in-lb torque wrench. Example: 6 ft-lb equals 72 in-lb.

Metric Cap Screw Identification

Sample:	M8-1.25 x 25		
Value:	M8	1.25	X 25
Meaning:	Major thread diameter in millimeters	Distance between threads in millimeters	Length in millimeters

Metric Cap Screw Head Markings

Metric cap screws and nuts are identified by the grade number stamped on the head of the cap screw or on the surface of the nuts.

Commercial Steel Class	8.8	10.9	12.9
Cap Screw Head Markings			

US Customary Cap Screw Identification

Sample:	5/16 x 18 x 1-1/2		
Value:	5/16	18	1-1/2
Meaning:	Major thread diameter in inches	Number of threads per inch	Length in inches

U.S. Customary Cap Screw Head Markings

U.S. Customary cap screws are identified by radial lines stamped on the head of the cap screw.

SAE Grade 5 w/ three lines	SAE Grade 8

Component Parts and Assemblies

Metric Cap Screw Torque Values (lubricated threads)

Class:	8.8				10.9				12.9			
Diameter	Cast Iron		Aluminum		Cast Iron		Aluminum		Cast Iron		Aluminum	
mm	N•m	ft-lb	N•m	ft-lb	N•m	ft-lb	N•m	ft-lb	N•m	ft-lb	N•m	ft-lb
6	9	5	7	4	13	10	7	4	14	9	7	4
7	14	9	11	7	18	14	11	7	23	18	11	7
8	23	17	18	14	33	25	18	14	40	29	18	14
10	45	33	30	25	65	50	30	25	70	50	30	25
12	80	60	55	40	115	85	55	40	125	95	55	40
14	125	90	90	65	180	133	90	65	195	145	90	65
16	195	140	140	100	280	200	140	100	290	210	140	100
18	280	200	180	135	390	285	180	135	400	290	180	135
20	400	290	—	—	550	400	—	—	—	—	—	—

U.S. Customary Cap Screw Torque Values (lubricated threads)

Grade:	SAE Grade 5				SAE Grade 8			
Cap Screw Body Size	Cast Iron		Aluminum		Cast Iron		Aluminum	
	N•m	ft-lb	N•m	ft-lb	N•m	ft-lb	N•m	ft-lb
1/4-20	9	7	8	6	15	11	8	6
1/4-28	12	9	9	7	18	13	9	7
5/16-18	20	15	16	12	30	22	16	12
5/16-24	23	17	19	14	33	24	19	14
3/8-16	40	30	25	20	55	40	25	20
3/8-24	40	30	35	25	60	45	35	25
7/16-14	60	45	45	35	90	65	45	35
7/16-20	65	50	55	40	95	70	55	40
1/2-13	95	70	75	55	130	95	75	55
1/2-20	100	75	80	60	150	110	80	60
9/16-12	135	100	110	80	190	140	110	80
9/16-18	150	110	115	85	210	155	115	85
5/8-11	180	135	150	110	255	190	150	110
5/8-18	210	155	160	120	290	215	160	120
3/4-10	325	240	255	190	460	340	255	190
3/4-16	365	270	285	210	515	380	285	210
7/8-9	490	360	380	280	745	550	380	280
7/8-14	530	390	420	310	825	610	420	310
1-8	720	530	570	420	1100	820	570	420
1-14	800	590	650	480	1200	890	650	480



7.5 CFP23E/EVS Radiator-cooled Assembly Drawings

Please refer to our website at www.cumminsfirepower.com for the most up-to-date information.

Description	Drawing No.
Assembly, Fire Pump, G-Drive CFP23E F10-F70	Per Job, A058N349
Options, Engine, G-Drive, CFP23E F10-F70 (QSK23) Rad	A042D340
Assembly, Radiator	A058N381
Assembly, Air Intake	17669
Assembly, Guarding, CFP23E F10-F70	23293
Assembly, Coolant Heater	A042J192
Assembly, Sensors and Harnessing	A042H300
Assembly, Secondary ECM CFP23E F10-F70	A042G636
Assembly, Control Panel Mounting	21249
Assembly, All Components Top-level:	
Assembly, Panel, Digital Electronic	A042G185
Battery Contactors 24V	8824-24
Kit, Fuel Lines	A042A380
Assembly, Stub Shaft and Guarding	16768
Schematic, CFP23E	A042J126
Assembly, VSPLC (FM-approved option)	A042E428

This page is intentionally left blank.



8

7

6

5

4

3

2

1

BILL OF MATERIAL

ITEM	QTY	DESCRIPTION	PART NUMBER
1	2	CONTACTOR, MANUAL OVERRIDE, 24V; PN:535-0098, FIREPUMP	8824-24
2	1	DRIVESHAFT, APT225 SHORT COUPLED; U3200 SERIES	13508
3	1	COMPANION FLANGE, U3200 SF; 3.750 x.875	13509-11
4	1	ASSEMBLY, CONTROL PANEL MOUNTING; CFP POWER UNITS	21249
5	2	KIT,GASKET,NUT,BOLT; FULL FACE FIBER,8	23580-800
6	2	SHIELD, 8" FLANGE RAIN;	25814
7	1	COUPLING, TORSIONAL; CFP23E F10-50, F15-35	26285
8	1	ASSEMBLY, BATTERY; CFP15E	26802
9	231	URETHANE, CLEAR COAT;	26867
10	1	8" ELBOW, NELSON;	40680K
11	1	SILENCER, CRITICAL GRADE, SPARK ARRESTING;	49880U
12	1	CAP, RAIN,8.3 INCH;	89483A
13	1	KIT, FUEL LINE; CFP23E	A042A380
14	1	GUARD, SHAFT; SAE 0	A042A569
15	1	ASSEMBLY, AIR FILTER; CFP23E, PLASTIC HOUSINGS	A042B204
16	1	ASSEMBLY, ACCESSORY MOUNTING; CFP23E	A042B206
17	1	SKID, CFP23; 165.00" L x 92.00 W"	A042B759
18	1	ENCLOSURE, INTERFACE; BATTERY CHARGER FIRE PUMP	A042C868
19	77	HARDENER, CLEAR COAT;	A042E529
20	77	REDUCER, CLEAR COAT;	A042E530
21	1	FLEX, 8" FLANGE EXHAUST; CFP23E	A042E964
22	1	ASSEMBLY, SECONDARY ECM; CFP23E	A042G363
23	1	ASSEMBLY,SENSOR & HARNESSING; CFP23E	A042H300
24	1	CONTROL ASSEMBLY; FPDP ELECTRONIC CARBON STEEL	A042H780
25	1	ASSEMBLY, COOLANT HEATER; CFP23E	A042J192
26	1	ASSEMBLY, 24VDC ENGINE; CFP23E-F10/20/30/40/50/60/70	A042K090
27	1	ASSEMBLY, OIL TEMPERATURE; SWITCH GAUGE, CFP23E	A057W281
28	1	FRAME, RADIATOR COOLED; CFP23E	A058N351
29	3	BRACKET, SILENCER MOUNTING; CFP23E ENCLOSED	A058N369
30	1	ASSEMBLY, ENGINE MOUNT; CFP23E, RADIATOR COOLED	A058N377
31	1	ENCLOSURE, FIREPUMP, CFP23; LEVEL 2 SOUND ATTENUATION	A058N378
32	1	ASSEMBLY, RADIATOR; CFP23E, HERESITE COATING	A058N382
33	1	HARNESS, DPDM CFP23E-F20;	A058N566
34	1	PAINT, SPRAY BOMB; CUMMINS RED	A15730-A12
35	1	PLUG, 1/2 NPT;	LTL-SCSP12
36	3	MOUNTING BAND, 22"; NELSON P/N Q27245	Q27245

REV	REL NO	REVISION	DWN	CKD	APVD	DATE
-	2017-581	RELEASED	HE392		NE627	05SEP2017

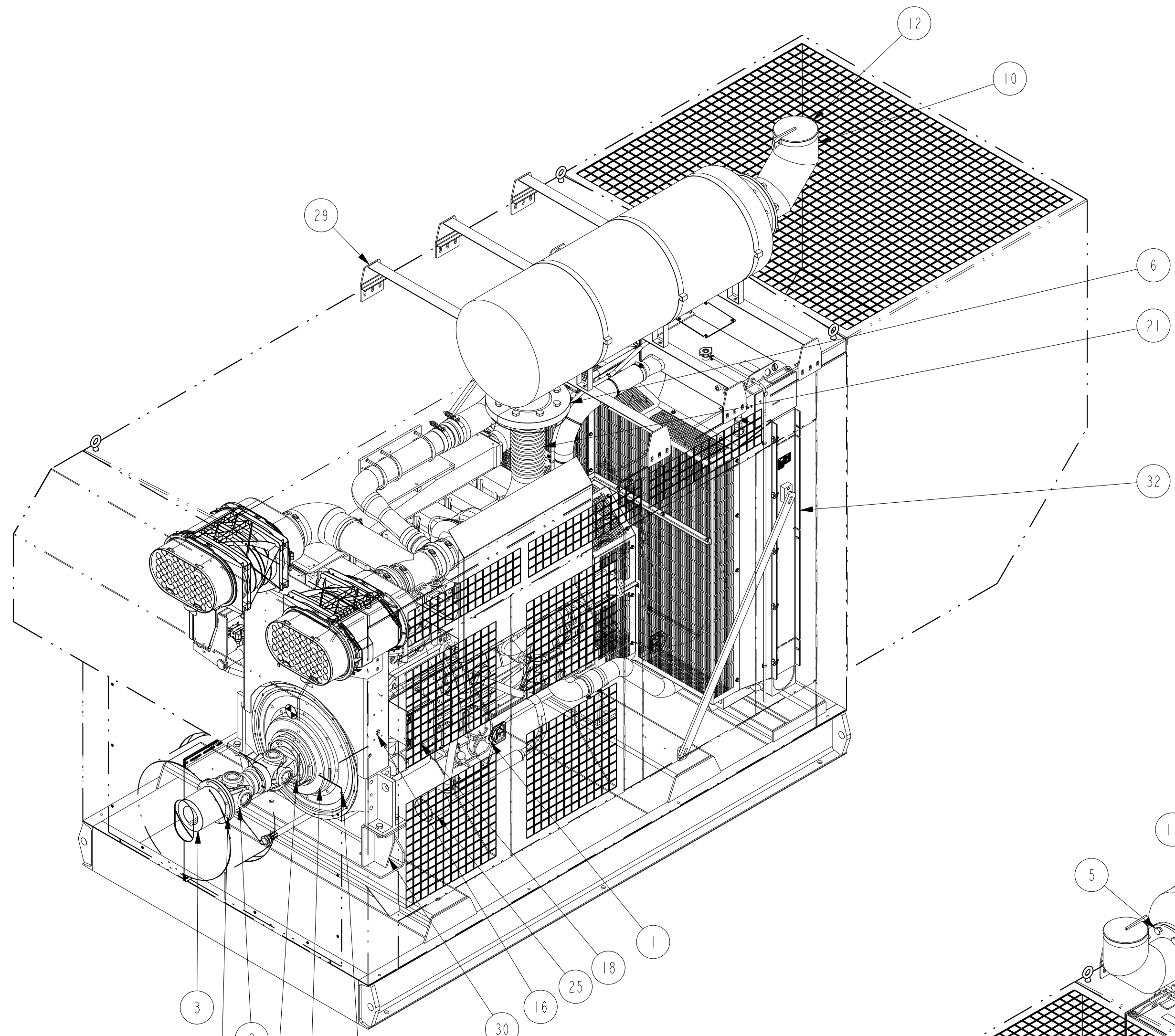

DRIVE SHAFT TO COMPANION FLANGE
M16-20 x 40mm LONG
GRADE 10.9, TORQUE TO 175 FT/LBS
(GRADE 12.9, TORQUE TO 210 FT/LBS)

DRIVE SHAFT TO U-JOINT ADAPTER
M16-20 x 40mm LONG
GRADE 10.9, TORQUE TO 175 FT/LBS
(GRADE 12.9, TORQUE TO 210 FT/LBS)

TORSIONAL COUPLING TO FLYWHEEL
1/2-13 x 1.88 LONG
GRADE 8, TORQUE TO 95 FT/LBS

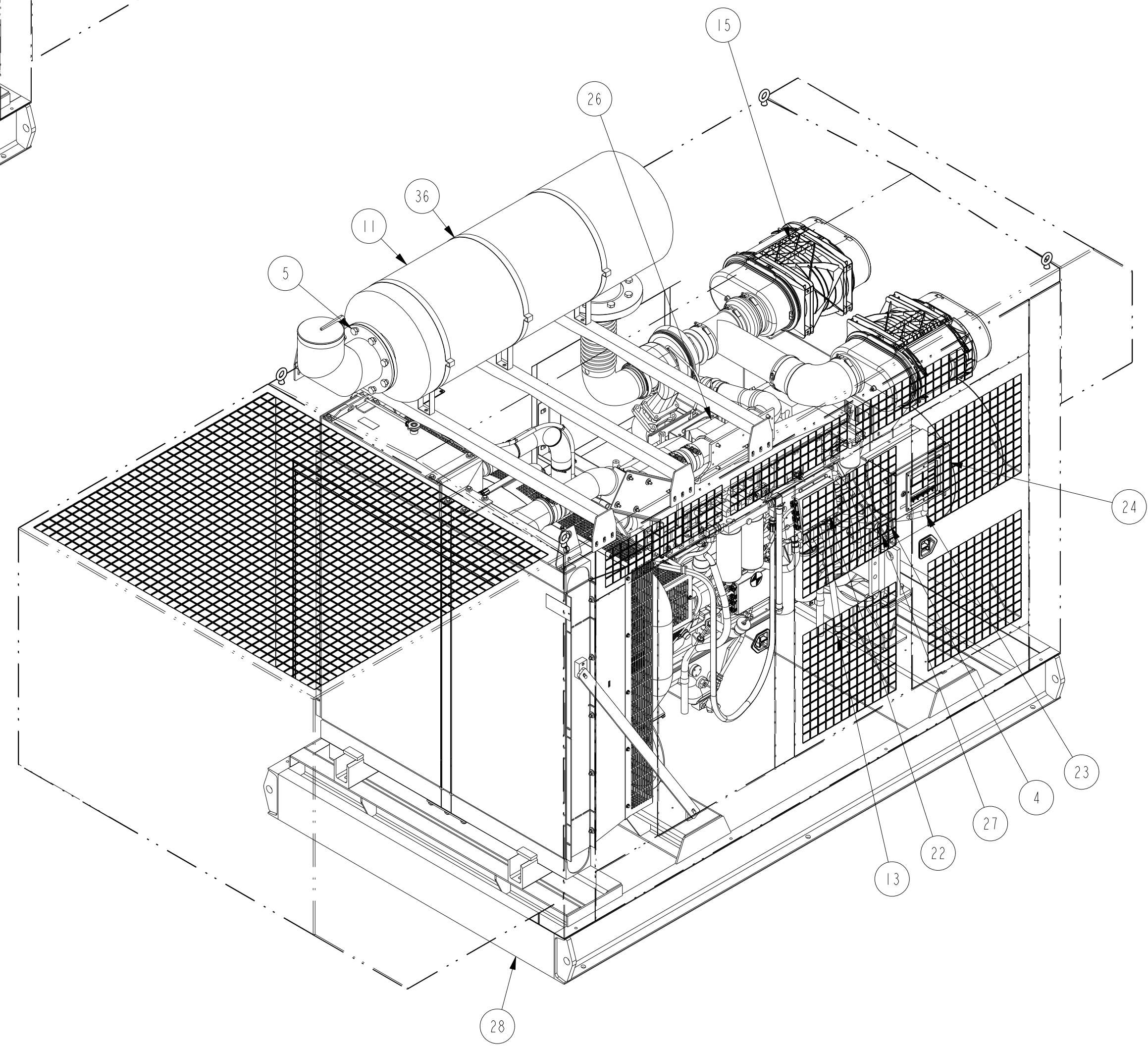

NOTE:
1. FINISH: COAT PER ES042 URETHANE CLEAR COAT

DIMENSIONS ARE IN: INCHES () ARE IN: .	DO NOT SCALE PRINT	CMI DATA CLASSIFICATION Cummins Confidential		Cummins Sales and Service	
DIMENSION TOLERANCES X.X: ±0.080IN OR 2.3mm X.XX: ±0.030IN OR 0.76mm X.XXX: ±0.015IN OR 0.38mm ANGULAR TOLERANCE: ±1°	SCALE 0.060	DWN HE392 CKD APVD NE627 DATE 16AUG2017		ITEM NAME ASSEMBLY, FIRE PUMP CFP23E-F20	ITEM NUMBER A058N349
<small>THIS DOCUMENT AND THE INFORMATION SHOWN THEREON IS CONFIDENTIAL AND PROPRIETARY AND SHALL NOT BE DISCLOSED TO OTHERS IN HARD COPY OR ELECTRONIC FORM, REPRODUCED BY ANY MEANS, OR USED FOR ANY PURPOSE WITHOUT WRITTEN CONSENT OF CUMMINS, INC.</small>			<small>FOR INTERPRETATION OF DIMENSIONING AND TOLERANCING, SEE ASME Y14.5-2009</small>	MUST CONFORM TO CES 10903	

8

7

6

5

4

3

2

1

REV	REL NO	REVISION	DWN	CKD	APVD	DATE
-	2017-581	SEE SHEET 1 FOR LATEST REVISION DETAILS	HE392		NE627	05SEP2017

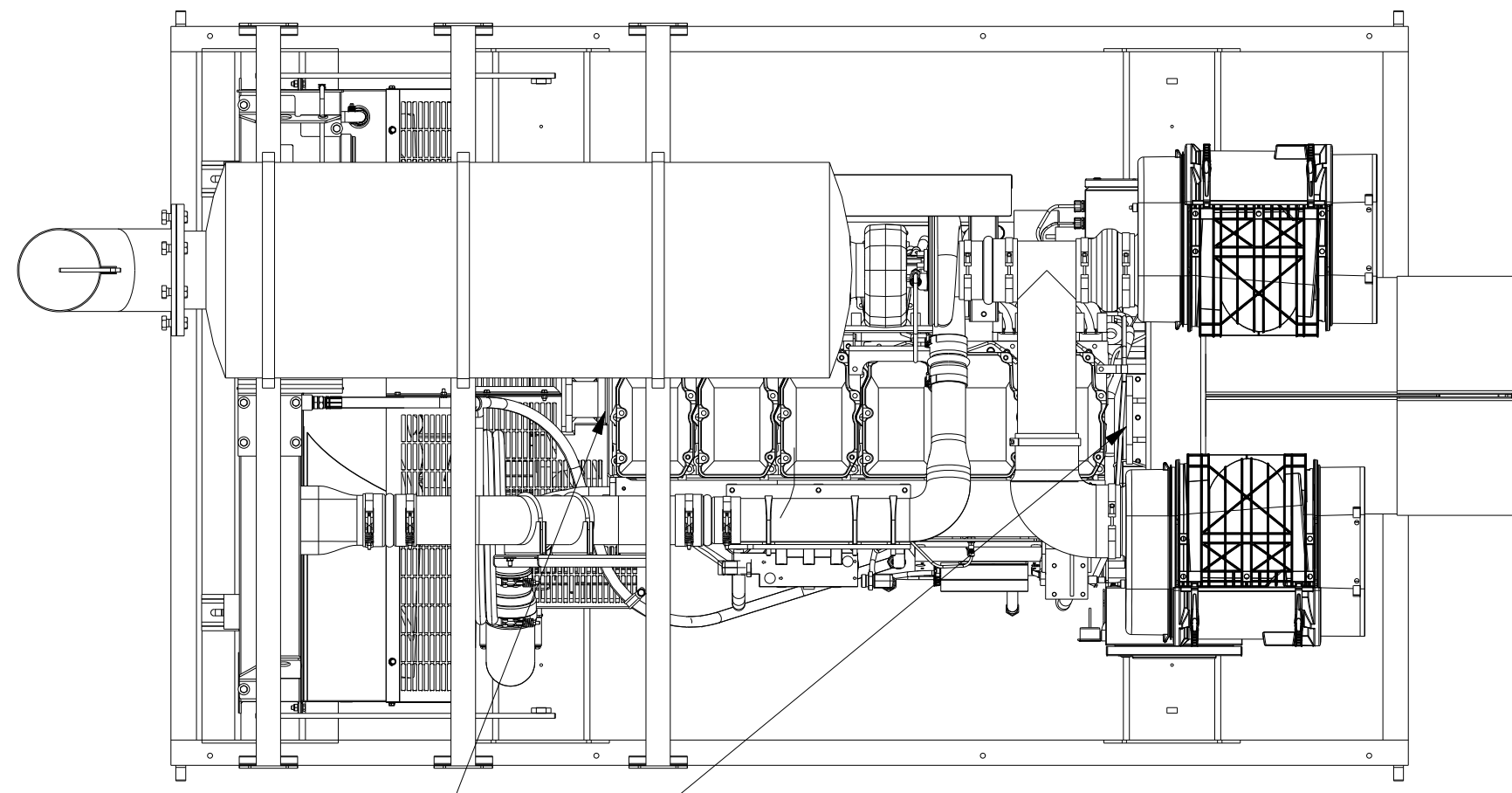

ENGINE ONLY
LIFTING POINTS

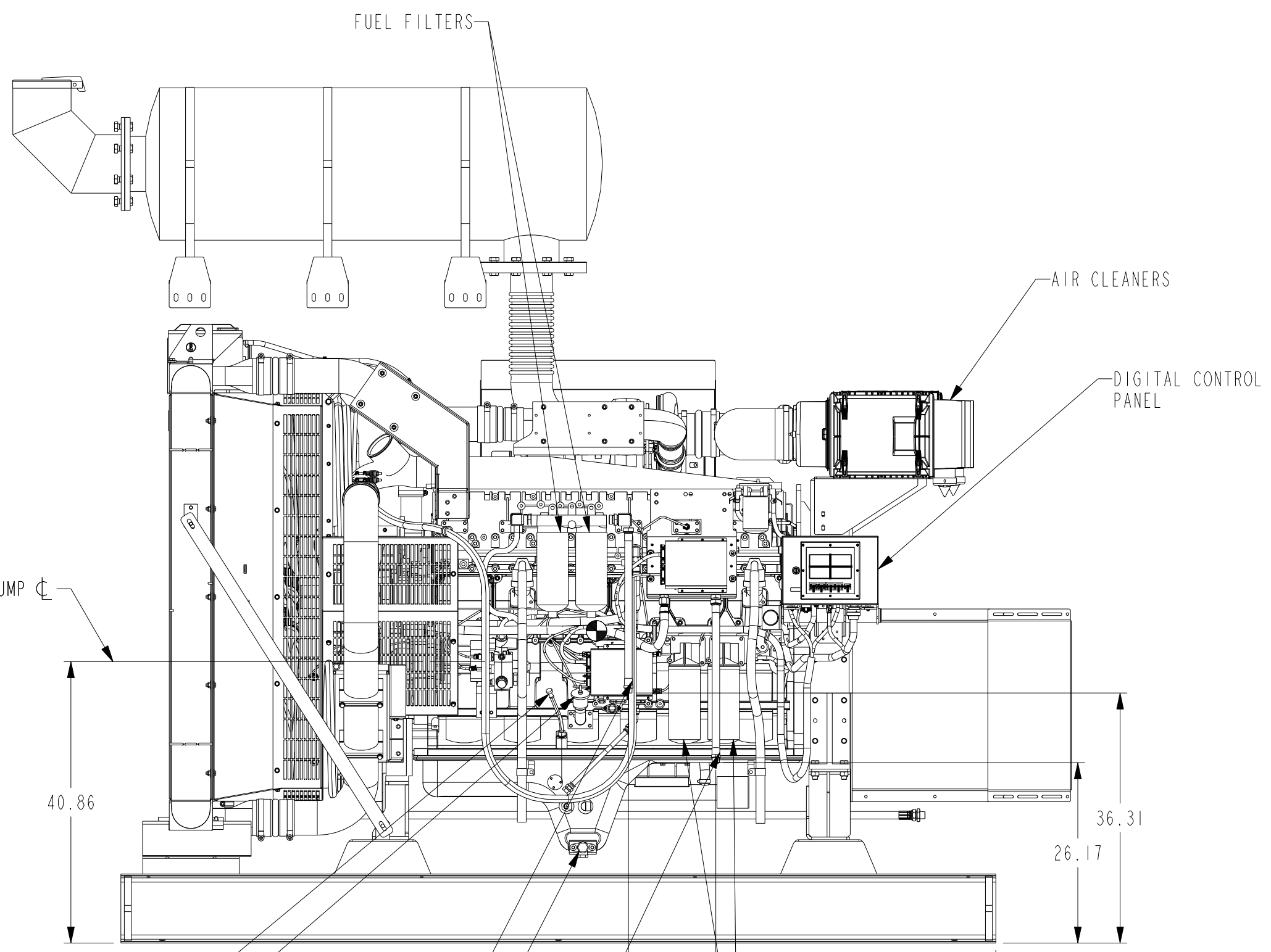

FUEL FILTERS

AIR CLEANERS

DIGITAL CONTROL PANEL

FUEL PUMP

40.86

36.31

26.17

40.64

53.33

LUBE OIL FILTERS

DIP STICK

LUBE OIL FILL

1" NPT FUEL SUPPLY
24" FUEL LINE EXTENSION

LUBE OIL DRAIN

1" NPT FUEL RETURN
24" FUEL LINE EXTENSION

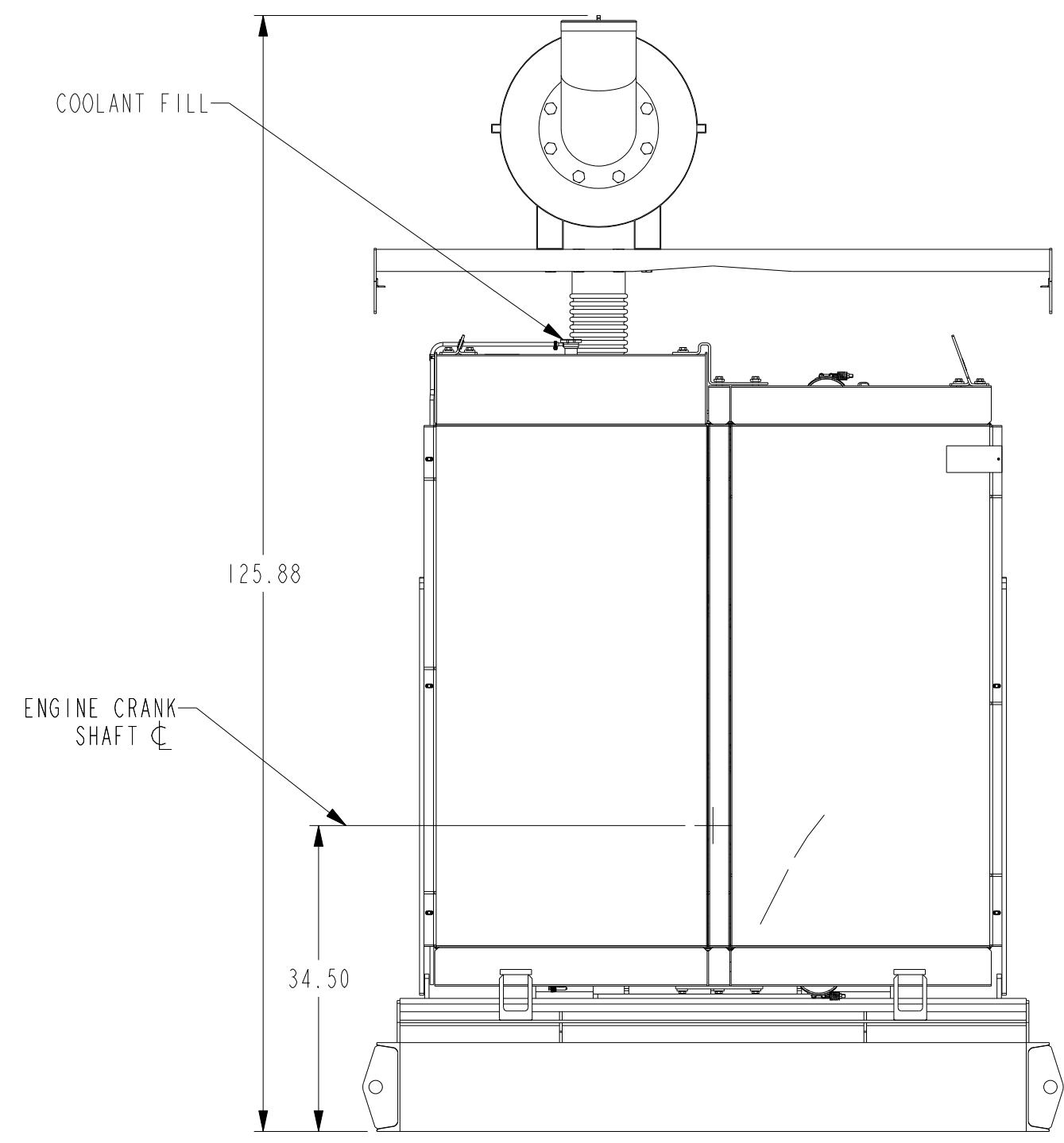

COOLANT FILL

125.88

ENGINE CRANK SHAFT

34.50

DIMENSIONS ARE IN: INCHES () ARE IN: . . .	DO NOT SCALE PRINT SCALE 0.060 	CMI DATA CLASSIFICATION Cummins Confidential DWN HE392 CKD APVD NE627 DATE 16AUG2017		Cummins Sales and Service	
				DIMENSION TOLERANCES X.X: ±0.080IN OR 2.3mm X.XX: ±0.030IN OR 0.76mm X.XXX: ±0.015IN OR 0.38mm ANGULAR TOLERANCE: ±1°	FOR INTERPRETATION OF DIMENSIONING AND TOLERANCING, SEE ASME Y14.5-2009

REV	REL NO	REVISION	DWN	CKD	APVD	DATE
-	2017-581	SEE SHEET 1 FOR LATEST REVISION DETAILS	HE392		NE627	05SEP2017

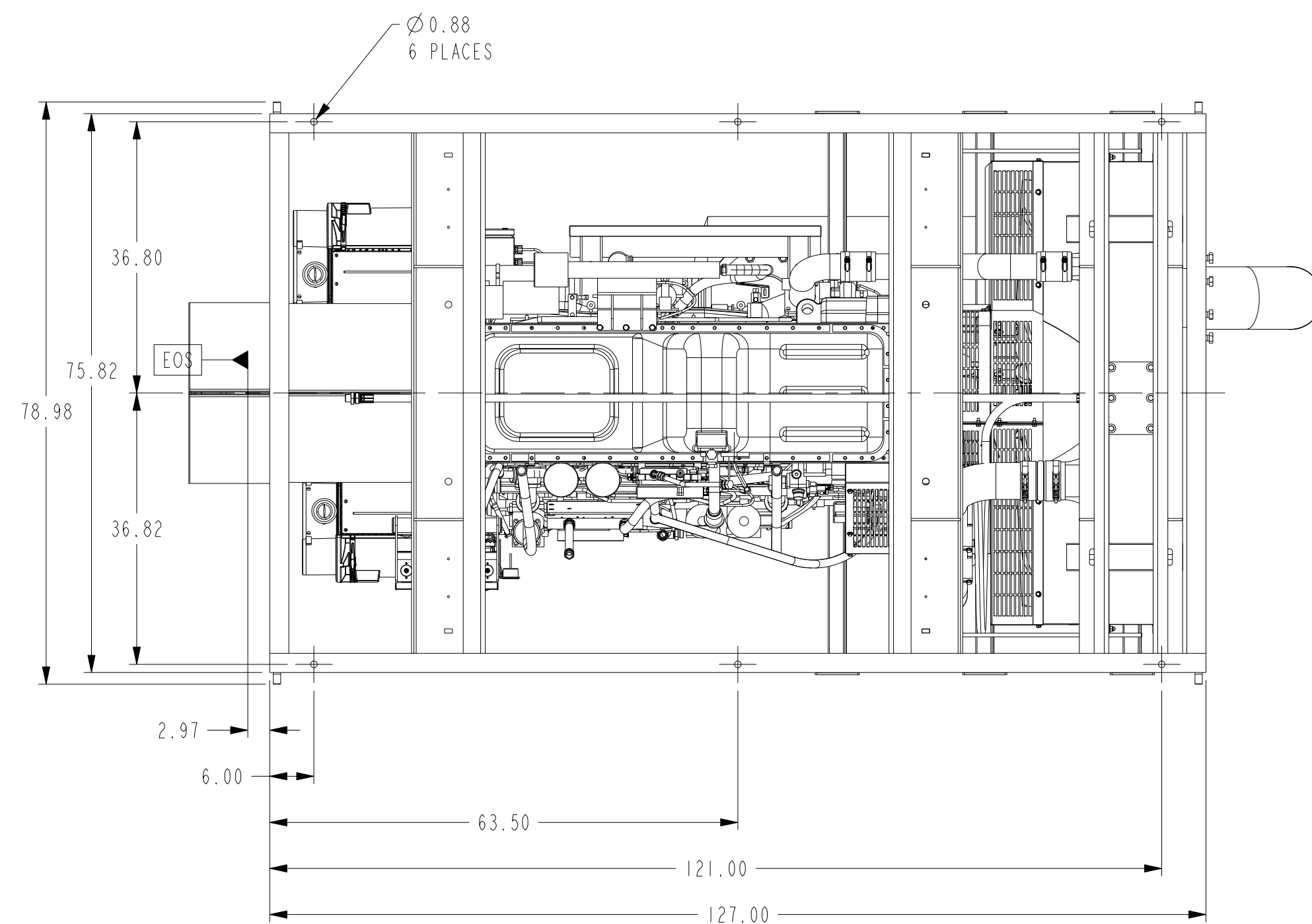
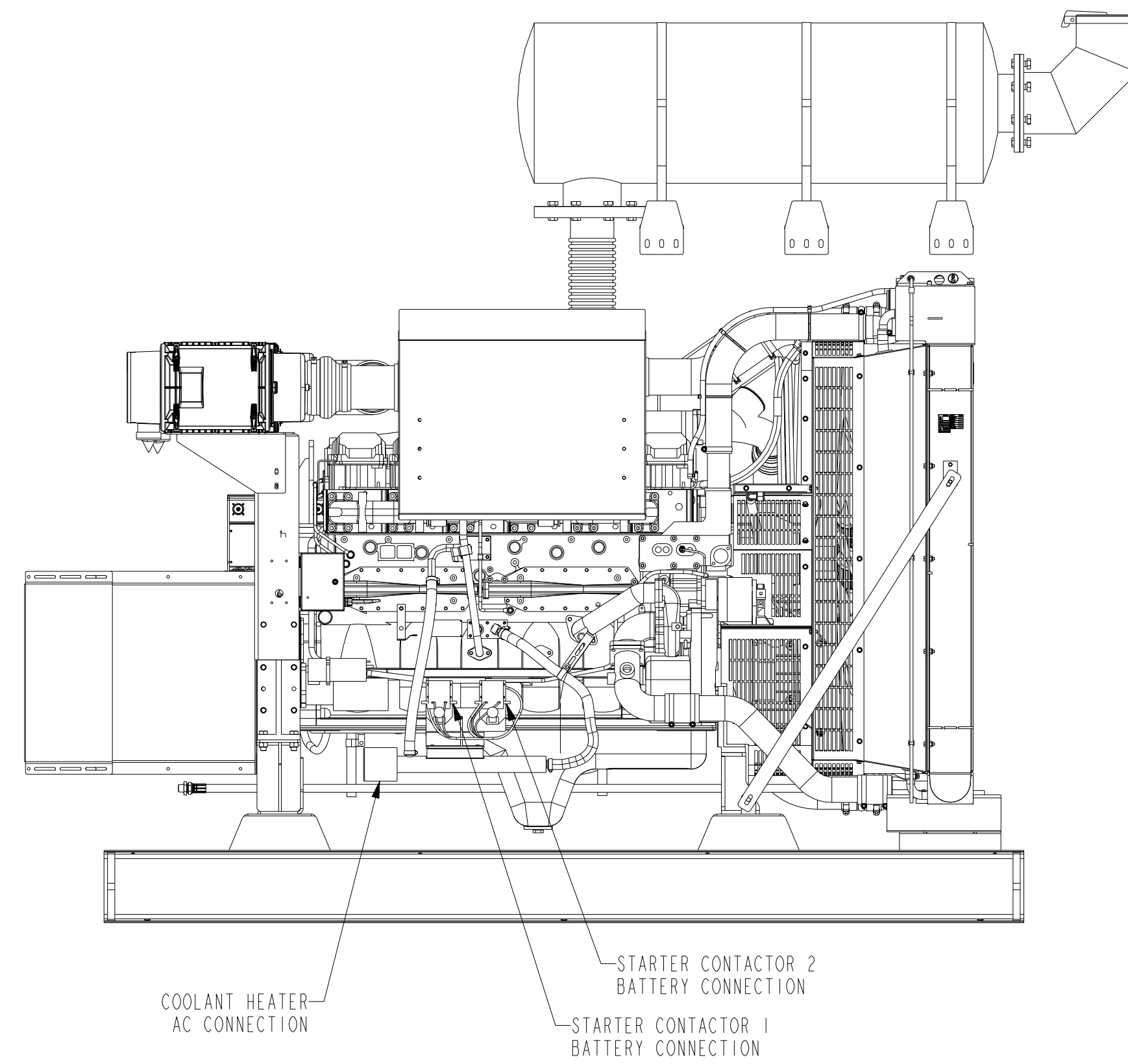
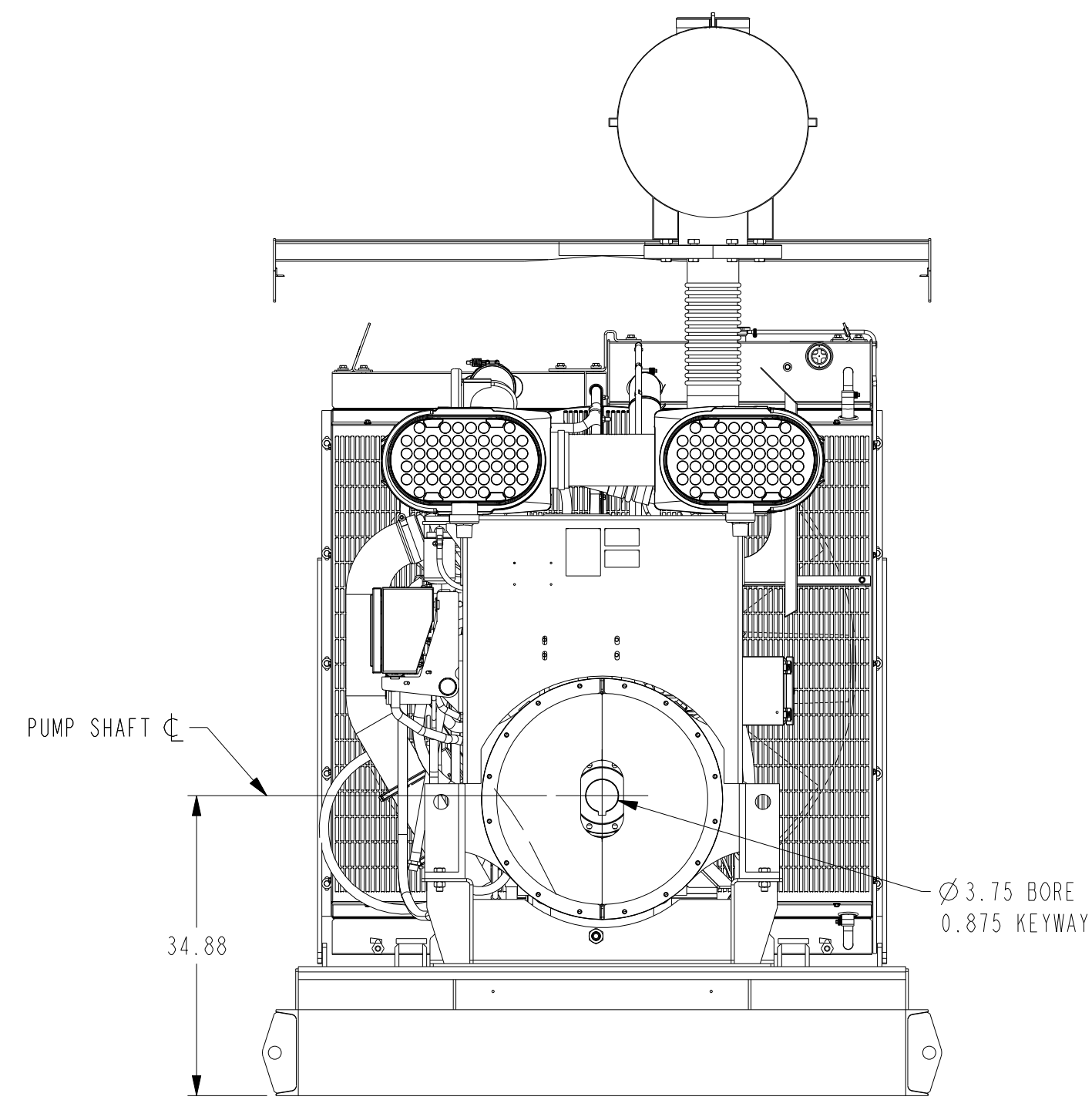

DIMENSIONS ARE IN: INCHES () ARE IN: . . .	DO NOT SCALE PRINT SCALE 0.060 	CMI DATA CLASSIFICATION Cummins Confidential DWN HE392 CKD APVD NE627 DATE 16AUG2017		Cummins Sales and Service	
				DIMENSION TOLERANCES X.X: \pm 0.080IN OR 2.3mm X.XX: \pm 0.030IN OR 0.76mm X.XXX: \pm 0.015IN OR 0.38mm ANGULAR TOLERANCE: \pm 1°	FOR INTERPRETATION OF DIMENSIONING AND TOLERANCING, SEE ASME Y14.5-2009

REV	REL NO	REVISION	DWN	CKD	APVD	DATE
-	2017-581	SEE SHEET 1 FOR LATEST REVISION DETAILS	HE392		NE627	05SEP2017

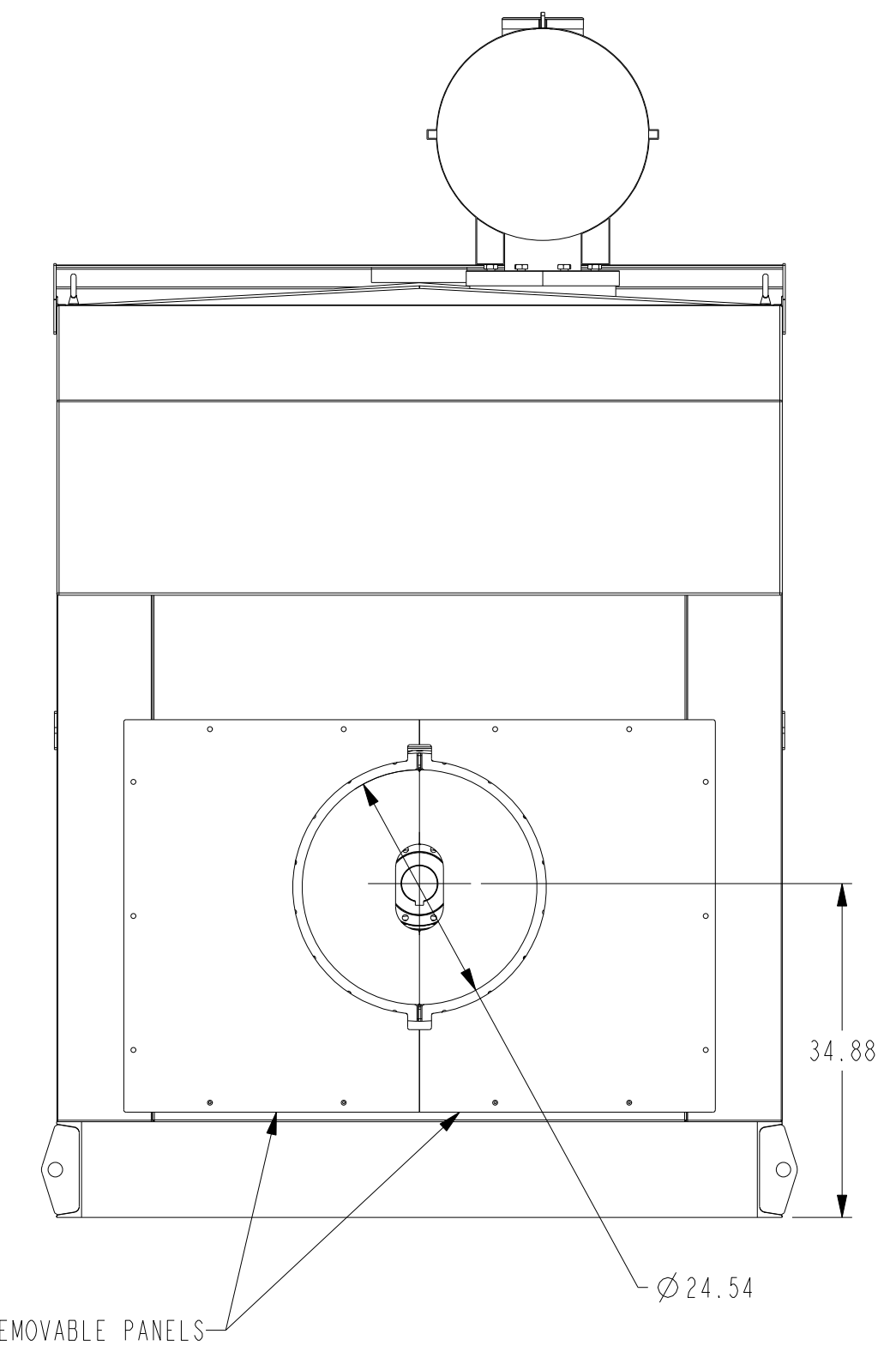
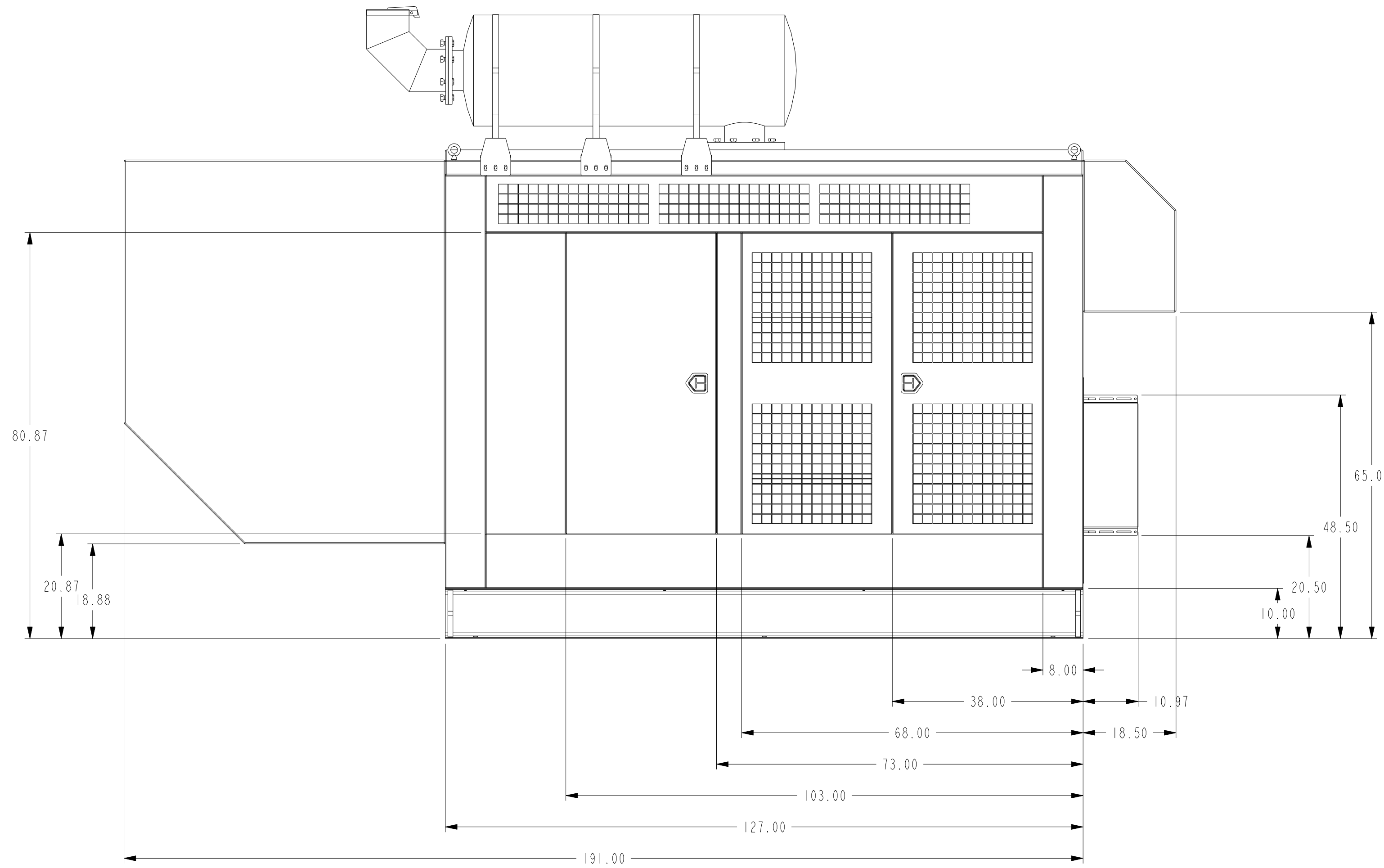
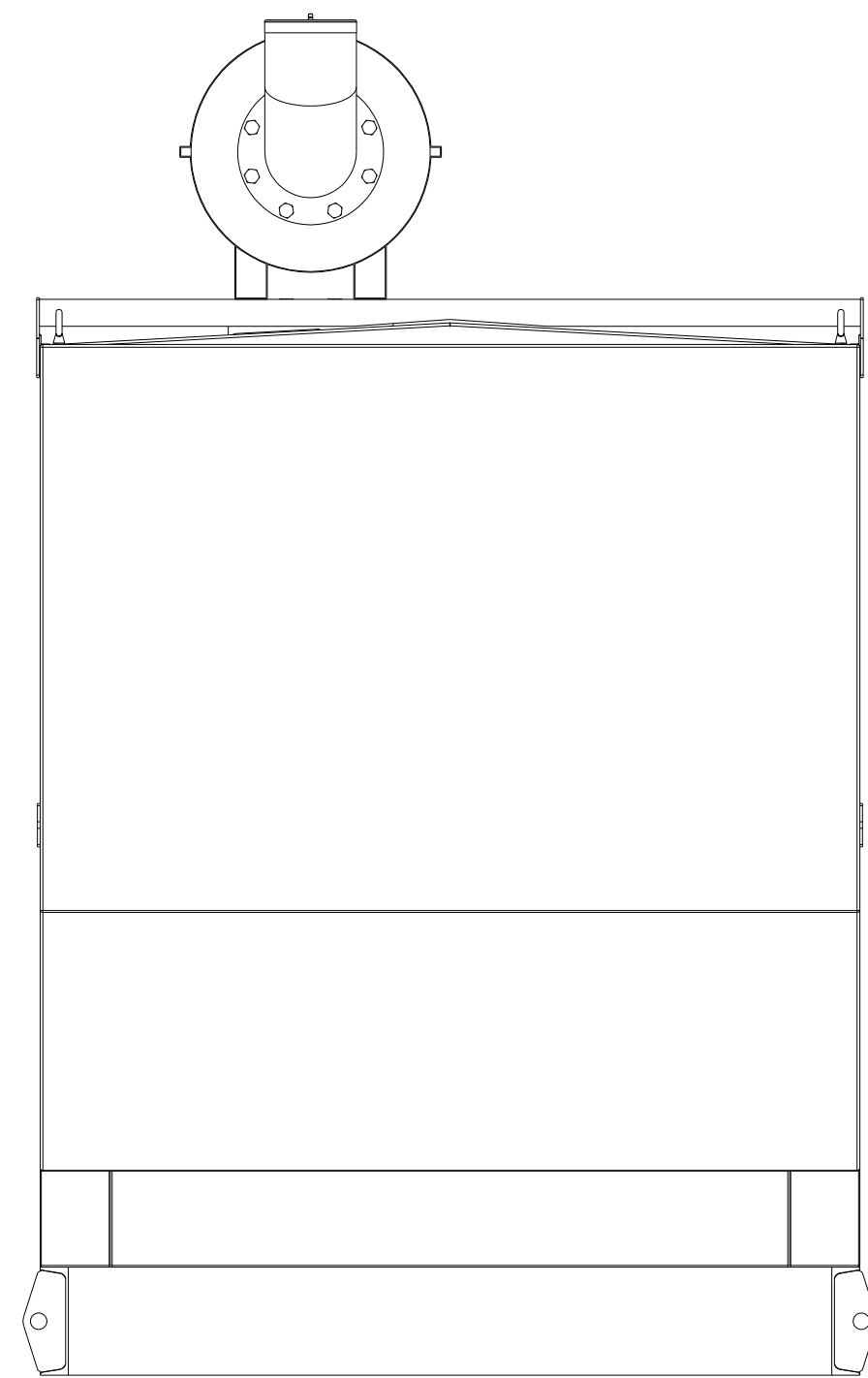

DIMENSIONS ARE IN: INCHES () ARE IN: . . .	DO NOT SCALE PRINT SCALE 0.060 	CMI DATA CLASSIFICATION Cummins Confidential DWN HE392 CKD APVD NE627 DATE 16AUG2017		Cummins Sales and Service	
				DIMENSION TOLERANCES X.X: ±0.080 IN OR 2.3mm X.XX: ±0.030 IN OR 0.76mm X.XXX: ±0.015 IN OR 0.38mm ANGULAR TOLERANCE: ±1°	FOR INTERPRETATION OF DIMENSIONING AND TOLERANCING, SEE ASME Y14.5-2009

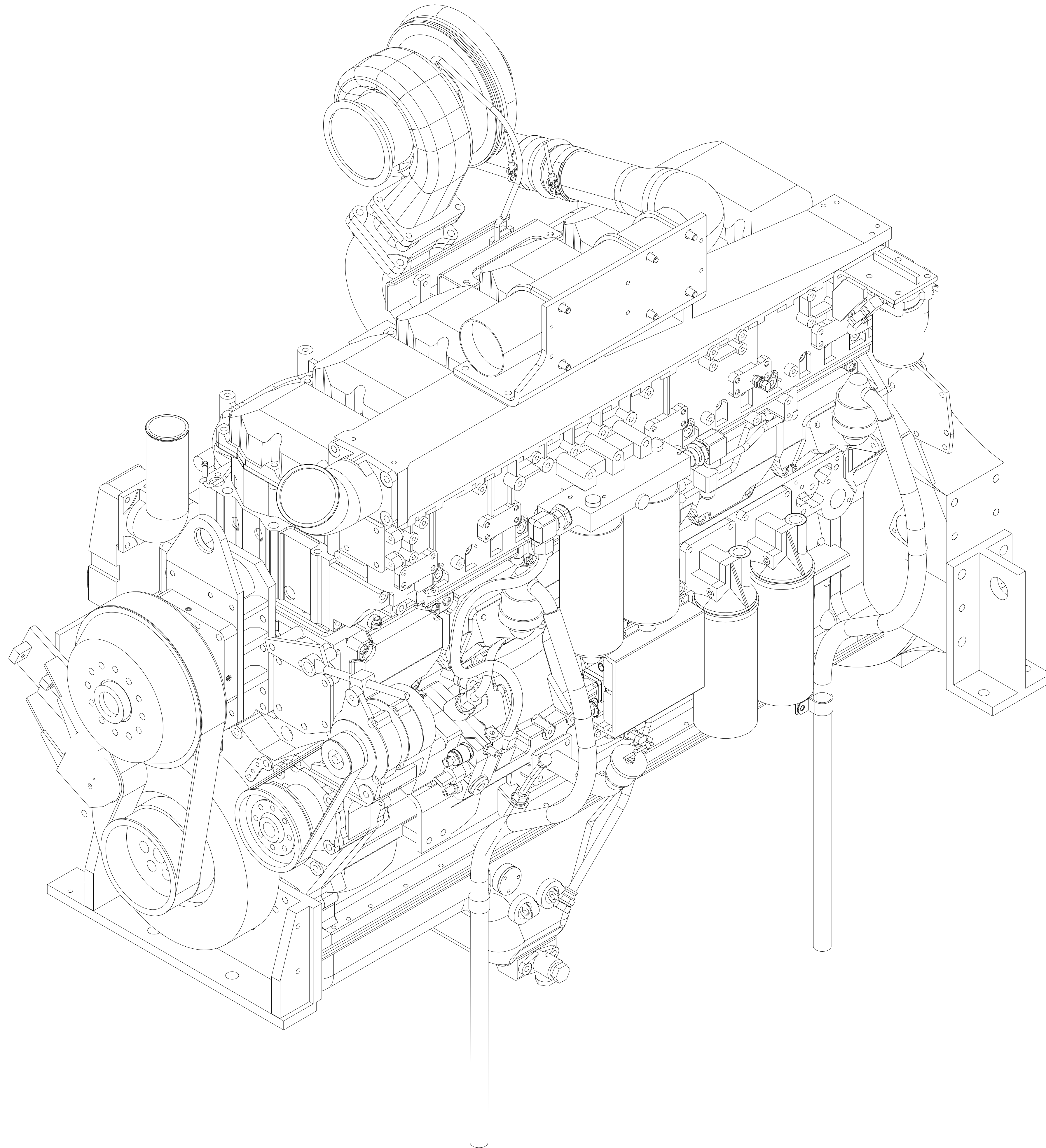

BILL OF MATERIAL			
ITEM	QTY	DESCRIPTION	PART NUMBER
1	1	BLOCK, CYLINDER	BB5714
2	1	ARRANGEMENT, CRC BREATHER	BR5012
3	1	COVER, CAM FOLLOWER	CM5707
4	1	DAMPER, VIBRATION	DA5706
5	1	DRIVE, FUEL PUMP	DP5707
6	1	ALTERNATOR	EE5094
7	1	MOUNTING, ALTERNATOR	EH5013
8	1	SUPPORT, FRONT ENGINE	EM5081
9	1	DRIVE, FAN	FA5103
10	1	FILTER, FUEL	FF5090
11	1	PLUMBING, FUEL FILTER	FF5769
12	1	HOUSING, FLYWHEEL	FH5074
13	1	PLUMBING, FLYWHEEL HOUSING	FH5775
14	1	PUMP, FUEL INJECTION	FP57003
15	1	PLUMBING, FUEL	FT5734
16	1	FLYWHEEL	FW5071
17	1	COVER, FRONT GEAR	GG5728
18	1	CONNECTION, AIR TRANSFER	IT5002
19	1	ARRANGEMENT, LIFTING	LA5002
20	1	COOLER, ENGINE OIL	LC5708
21	1	FILTER, LUBRICATING OIL	LF5088
22	1	GAUGE, OIL LEVEL	LG5703
23	1	PUMP, LUBRICATING OIL	LP5702
24	1	ARRANGEMENT, OIL FILL	OB5058
25	1	PAN, OIL	OP5145
26	1	PLUMBING, OIL PAN	OP5726
27	1	PARTS, PERFORMANCE	PP43352
28	1	TURBOCHARGER	PP5718
29	1	DRAIN, REMOTE OIL	RD5002
30	1	MOUNTING, STARTING MOTOR	SM5723
31	1	MOTOR, STARTING	ST5038
32	1	ARRANGEMENT, TURBOCHARGER	TB5076
33	1	MANIFOLD, AIR INTAKE	TB5795
34	1	HOUSING, THERMOSTAT	TH5709
35	1	PLUMBING, TURBOCHARGER	TP5725
36	1	COVER, VALVE	VC5704
37	1	RESISTOR, CORROSION	WF5032
38	1	CONNECTION, WATER INLET	WI5065
39	1	CONNECTION, WATER OUTLET	WO5036
40	1	PUMP, WATER	WP5702
41	1	ECM, CM500	4921411
42	1	APPROVAL, AGENCY	AP5129
43	1	DOCUMENTATION, DCN IPN	AP5705
44	1	COMPONENTS, BASE	BC5015
45	1	DRIVE, BARRING	CB5706
46	1	SOFTWARE, CUS INTERFACE	DO5480
47	1	THERMOSTAT	EC5705
48	1	CALIBRATION, FUEL PUMP	FCAB02800
49	1	RATING, FUEL	FR50069
50	1	MOUNTING, ENG CNT MODULE	PH57011
51	1	MODULE, ENGINE CONTROL	PH57027
52	1	LEVER, ROCKER	RL5703
53	1	SOFTWARE, CALIBRATION	SC50378
54	1	PAINT, RED	SS5025
55	1	HARNESS, ETR CNT MDL WRG	WR5702

This document contains confidential and trade secret information, is the property of Cummins Fire Power LLC and is to be used only for the purposes intended. It is not to be distributed, copied, or otherwise used without the express written permission of Cummins Fire Power LLC. If you are not an authorized user, you should not have received this document. If you have received this document in error, please notify Cummins Fire Power LLC immediately. This document is for informational purposes only and does not constitute an offer or any other financial product. Cummins Fire Power LLC is not a financial institution and does not provide financial services. Cummins Fire Power LLC is not a broker or dealer in securities. Cummins Fire Power LLC is not a registered investment advisor. Cummins Fire Power LLC is not a fiduciary. Cummins Fire Power LLC is not a financial planner. Cummins Fire Power LLC is not a financial advisor. Cummins Fire Power LLC is not a financial consultant. Cummins Fire Power LLC is not a financial analyst. Cummins Fire Power LLC is not a financial strategist. Cummins Fire Power LLC is not a financial tactician. Cummins Fire Power LLC is not a financial operator. Cummins Fire Power LLC is not a financial manager. Cummins Fire Power LLC is not a financial executive. Cummins Fire Power LLC is not a financial officer. Cummins Fire Power LLC is not a financial director. Cummins Fire Power LLC is not a financial supervisor. Cummins Fire Power LLC is not a financial controller. Cummins Fire Power LLC is not a financial administrator. Cummins Fire Power LLC is not a financial clerk. Cummins Fire Power LLC is not a financial assistant. Cummins Fire Power LLC is not a financial secretary. Cummins Fire Power LLC is not a financial receptionist. Cummins Fire Power LLC is not a financial messenger. Cummins Fire Power LLC is not a financial courier. Cummins Fire Power LLC is not a financial driver. Cummins Fire Power LLC is not a financial chauffeur. Cummins Fire Power LLC is not a financial valet. Cummins Fire Power LLC is not a financial concierge. Cummins Fire Power LLC is not a financial butler. Cummins Fire Power LLC is not a financial doorman. Cummins Fire Power LLC is not a financial porter. Cummins Fire Power LLC is not a financial bellhop. Cummins Fire Power LLC is not a financial valet. Cummins Fire Power LLC is not a financial driver. Cummins Fire Power LLC is not a financial chauffeur. Cummins Fire Power LLC is not a financial valet. Cummins Fire Power LLC is not a financial concierge. Cummins Fire Power LLC is not a financial butler. Cummins Fire Power LLC is not a financial doorman. Cummins Fire Power LLC is not a financial porter. Cummins Fire Power LLC is not a financial bellhop.

Cummins Fire Power
 CUMMINS FIRE POWER LLC
 CORPORATE OFFICE
 1600 BUREAU ROAD
 WHITE SEAR LAKE, MN
 WWW.CUMMINSFIREPOWER.COM

CUSTOM DESIGN AND UPGRADE CENTER
 875 LAWRENCE DRIVE
 DEPERE, WISCONSIN

ENGINE, CFP23E, RADIATOR COOLED
 1220 HP @ 1760 RPM - BC51062

DWG UNITS: IN/LB/S
 SCALE: 0.250
 EST WEIGHT:

DRAWN BY: PBS
PRO-ENGINEER
 SHEET 1 OF 1

DATE: 13JUL2015
 INIT ECO: 2015-425
 DRAWING NO: A042D340

REV	ECO	DESCRIPTION OF REVISION	REV BY	DATE

BILL OF MATERIALS			
ITEM	QTY	DESCRIPTION	PART NUMBER
1	2	BRACKET, HEAT SHIELD MOUNT; CFP23E	13134
2	1	HEAT SHIELD; CFP23E	13135
3	1	TAG; ENGINE WEIGHT	16825
4	1	ASSEMBLY, RADIATOR; CFP23E	A058N350
5	2	BRACE, RADIATOR;	A058N368

REV	REL NO	REVISION	DWN	CKD	APVD	DATE
-	2017-581	RELEASED	HE392		NE627	05SEP2017

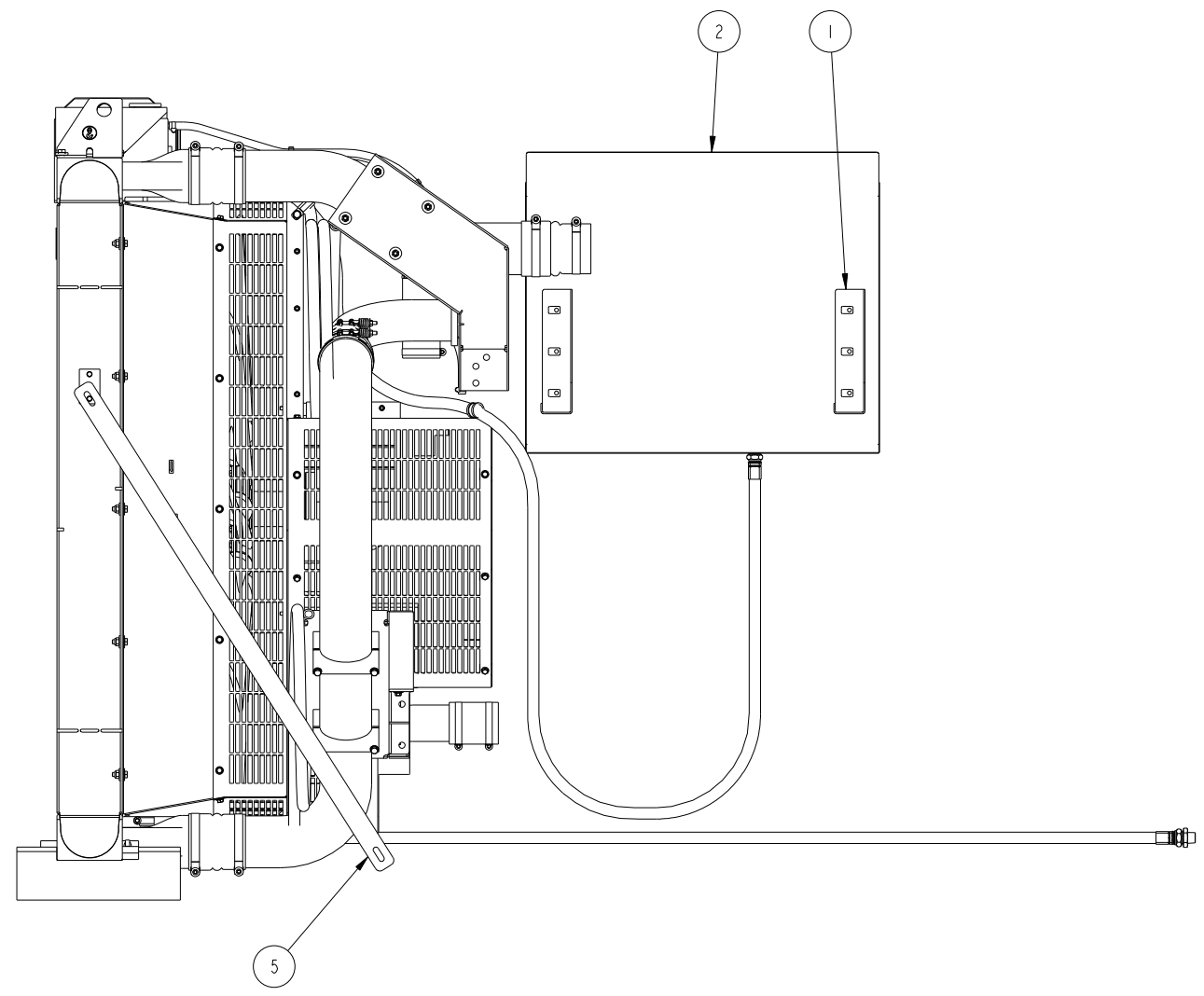
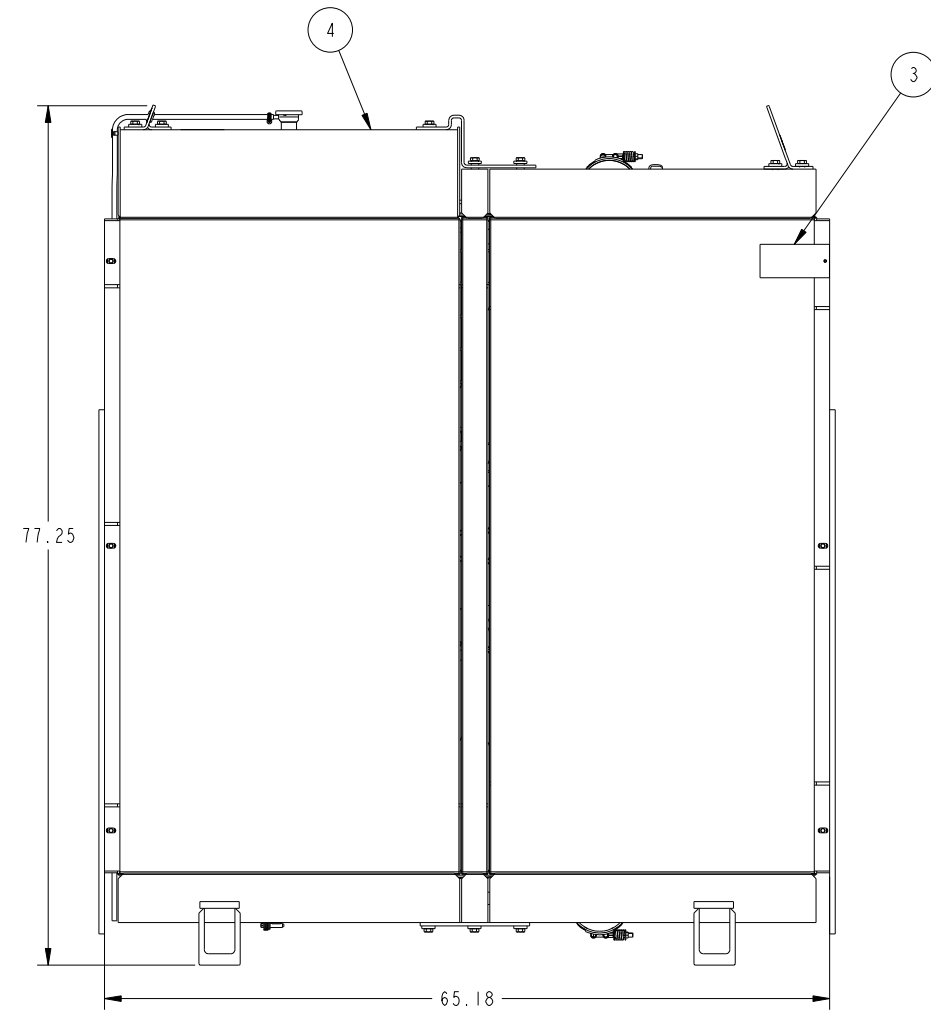

DIMENSIONS ARE IN: INCHES E 1 ARE IN: .	DO NOT SCALE PRINT	CMV DATA CLASSIFICATION Cummins Confidential		Cummins Sales and Service	
DIMENSION TOLERANCES X.I: ±0.0010 IN OR 2.3mm X.II: ±0.0010 IN OR 0.16mm X.III: ±0.0150 IN OR 0.38mm ANGULAR TOLERANCE: ±1°	SCALE .125	DWN HE392 CKD APVD NE627 DATE 05SEP2017		ITEM NAME ASSEMBLY, RADIATOR CFP23E	ITEM NUMBER A058N381
THIS DOCUMENT (AND THE INFORMATION SHOWN THEREON) IS CONFIDENTIAL AND PROPRIETARY AND SHALL NOT BE DISCLOSED TO OTHERS IN ANY MANNER OR BY ANY MEANS, OR REPRODUCED IN ANY MANNER, OR USED FOR ANY PURPOSE WITHOUT WRITTEN CONSENT OF CUMMINS INC.			FOR INTERPRETATION OF DIMENSIONING AND TOLERANCING, SEE ASME Y14.5-2009		MUST CONFORM TO CES 10903

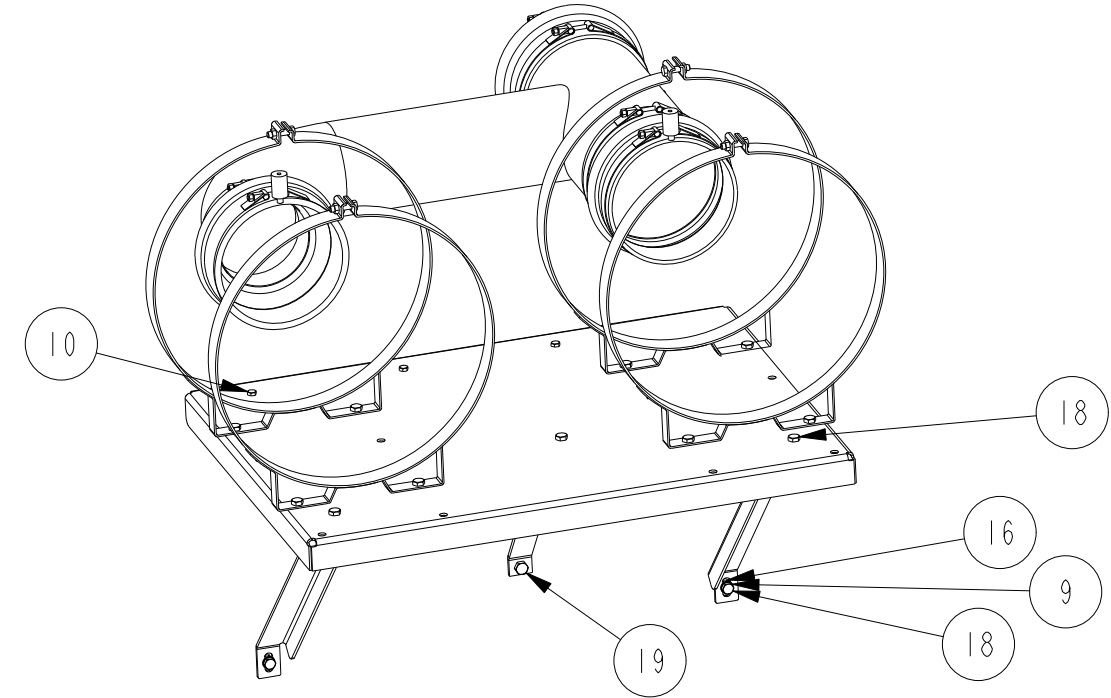
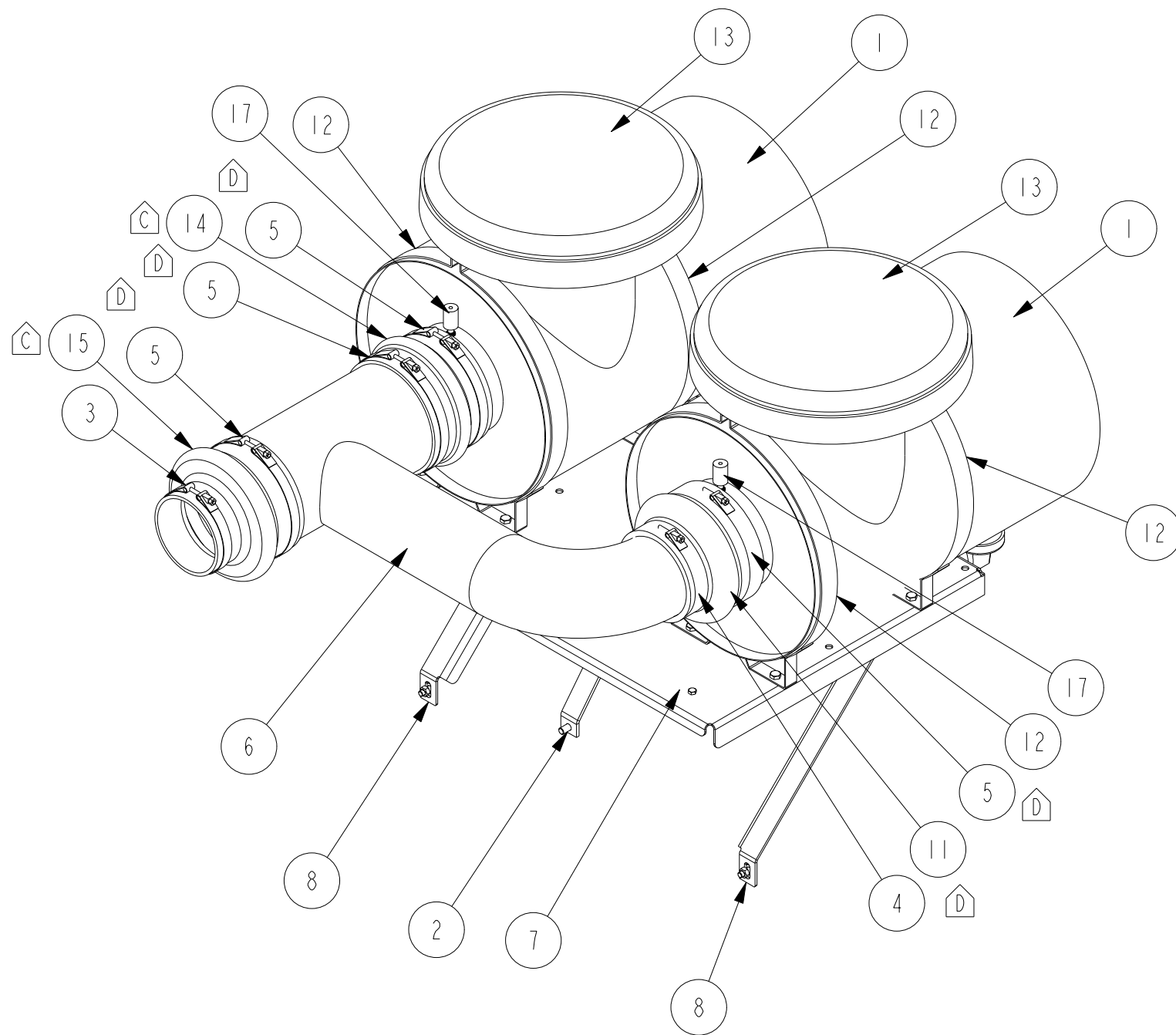

BILL OF MATERIAL

ITEM	QTY	DESCRIPTION	PART NUMBER
1	2	AIR HOUSING ASSEMBLY, FLEETGUARD AH19076	AH19076
2	1	BRACKET, STIFFENER, OPERATOR STATION, CFP23E FIREPUMP	13121
3	1	CLAMP, T-BOLT, 5.78-6.09	13164-0600
4	1	CLAMP, T-BOLT, 6.28-6.59	13164-0650
5	4	CLAMP, T-BOLT, 8.25-8.56	13164-0850
6	1	TUBE, AIR CLEANER, CFP23E	17693
7	1	BRACKET, AIR CLEANER, CFP23E	17694
8	2	BRACE, HD AIR CLEANER, CFP23E	18607
9	5	WASHER, FLAT, M10	20020-M10
10	3	SCREW, HH, 0.31-18x0.75	20231-075
11	1	HUMP HOSE, 8" TO 6"	3316626S
12	4	BRACKET, AIR CLEANER, 18.10 INCH ID	3918237S
13	2	INTAKE BONNET, 10", FLEETGUARD 3940356S OR EQUIV	3940356S
14	1	HOSE, HUMP, 8"x8"	3316614-S
15	1	HOSE, HUMP-REDUCER, 8.0" TO 5.5"	3316625-S
16	13	NUT, HEX, PT, M10-1.50	20140-M10
17	2	RESTRICTION INDICATOR, 1/8" NPT	RAX00-2352
18	13	SCREW, HH, M10-1.50x25	20310-025
19	1	SCREW, HH, M12-1.75x25	20312-025

This document contains confidential and trade secret information, is the property of Cummins Fire Power LLC and is given to the receiver in confidence. The receiver, by receiving and retaining of the document accepts the document in confidence and agrees that, except as authorized in writing by Cummins NPower, it will (1) not use the document or any copy thereof or the confidential or trade secret information therein, (2) not copy the document, (3) not disclose to others either the document or the confidential or trade secret information therein, and (4) upon completion of the need to retain the document, or upon demand, return the document, all copies thereof, and all material copied therefrom. COPYRIGHT Cummins Fire Power LLC



CUMMINS FIRE POWER LLC
CORPORATE OFFICE
1600 BUERKLE ROAD
WHITE BEAR LAKE, MN
WWW.CUMMINSFIREPOWER.COM

CUSTOM DESIGN
AND UPFIT CENTER
875 LAWRENCE DRIVE
DEPERE, WISCONSIN

D	2014-275	DELETE: 13164-0675, 13164-0875 ADD: 13164-0650, 13164-850	PBS	01MAY2014
C	2014-131	3316614-S REPLACED 89841K 3316625-S REPLACED 89855K	S DUBICK	25-FEB-14
REV	ECO	DESCRIPTION OF REVISION	REV BY	DATE

UNLESS OTHERWISE SPECIFIED ALL DIMENSION TOLERANCES ARE

ANGULAR DIMENSIONS ± 1°	MACHINED SURFACES	IMPERIAL UNITS	METRIC UNITS
		MACHINE TOLERANCES .XX ± 0.010 .XXX ± 0.005	MACHINE TOLERANCES .X ± 0.4 .XX ± 0.2
THIRD ANGLE PROJECTION	125	FORM TOLERANCES .XX ± 0.030 .XXX ± 0.015	FORM TOLERANCES .X ± 0.4 .XX ± 0.2
		FAB TOLERANCES .XX ± 0.060 .XXX ± 0.030	FAB TOLERANCES .X ± 0.5 .XX ± 0.3

SYSTEM, AIR CLEANER CFP23E

DWG UNITS: 1N/LB/S
SCALE: 0.100
EST WEIGHT: 0.000

DRAWN BY: DAN
PRO-ENGINEER

DATE: 23-AUG-10
INIT ECO: 2010-373

SHEET 1 OF 1
DRAWING NO: 17669

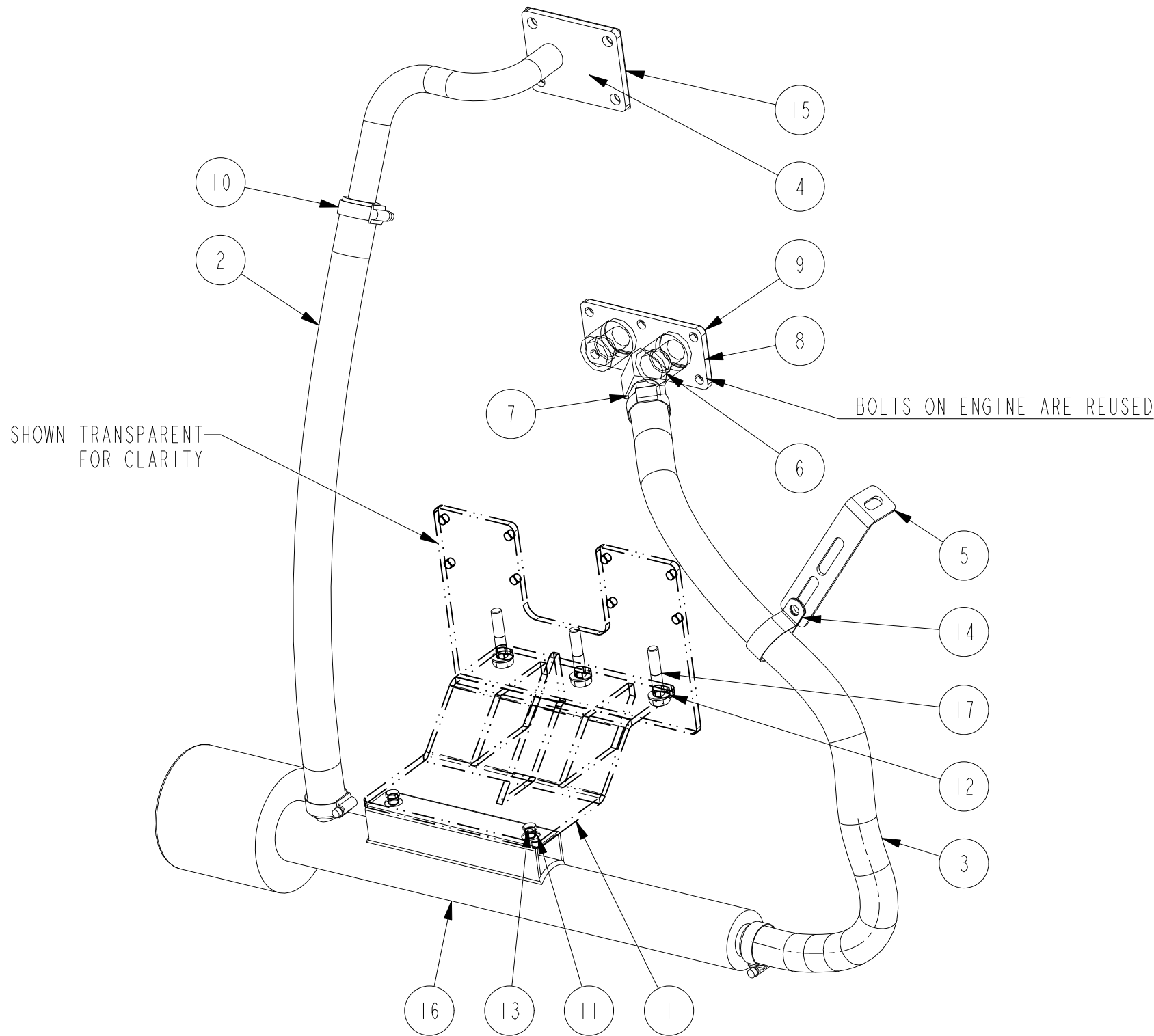

BILL OF MATERIAL			
ITEM	QTY	DESCRIPTION	PART NUMBER
1	1	BRACKET, COOLANT HEATER/CONTACTOR, CFP23E	14046
2	1	HOSE, 1.00IN IDX36IN, SILICONE, CUT TO 26.00 INCHES LONG	A042F061
3	1	HOSE, 1.00IN IDX36IN, SILICONE, CUT TO 29.00 INCHES LONG	A042F061
4	1	PLATE, COVER, CFP23E	A042J195
5	1	BRACKET, MOUNTING, TUBE SUPPORT, FIREPUMP	8657
6	1	ELB, 45 DEG, -12 NPT X -12 FMNPT	12532-12-12
7	1	FTG, STR, -16 BEAD X -12 NPT	12545-16-12
8	1	BRACKET, COOLANT HEATER CONNECT, CFP23E	13585
9	1	GASKET, COOLANT HEATER, CFP23E	13875
10	4	CLAMP, WORM, .81 - 1.50	14990-16
11	2	WASHER, FLAT, 0.25	20020
12	3	WASHER, FLAT, M10	20020-M10
13	2	SCREW, HH, 0.25-20x0.75	20225-075
14	1	CLAMP, LOOM, 1.50 ID	26963-24
15	1	GASKET, COVER PLATE, CUMMINS	3094281
16	1	HEATER, COOLANT, 4000W, ADJ. VOLTAGE, WATLOW CPBPH7S12	CPBPH7S12
17	3	SCREW, HH, M10-1.50x50	20310-050

This document contains confidential and trade secret information, is the property of Cummins Fire Power LLC and is given to the receiver in confidence. The receiver, by receiving and retaining of the document accepts the document in confidence and agrees that, except as authorized in writing by Cummins NPower, it will (1) not use the document or any copy thereof or the confidential or trade secret information therein, (2) not copy the document, (3) not disclose to others either the document or the confidential or trade secret information therein, and (4) upon completion of the need to retain the document, or upon demand, return the document, all copies thereof, and all material copied therefrom. COPYRIGHT Cummins Fire Power LLC



CUMMINS FIRE POWER LLC
CORPORATE OFFICE
1600 BUERKLE ROAD
WHITE BEAR LAKE, MN
WWW.CUMMINSFIREPOWER.COM

CUSTOM DESIGN
AND UPFIT CENTER
875 LAWRENCE DRIVE
DEPERE, WISCONSIN

UNLESS OTHERWISE SPECIFIED ALL DIMENSION TOLERANCES ARE			
ANGULAR DIMENSIONS ± 1°	MACHINED SURFACES	IMPERIAL UNITS .XX ± 0.010 .XXX ± 0.005	METRIC UNITS .X ± 0.4 .XX ± 0.2
THIRD ANGLE PROJECTION	125	FORM TOLERANCES .XX ± 0.030 .XXX ± 0.015	FORM TOLERANCES .X ± 0.8 .XX ± 0.4
REV	ECO	DESCRIPTION OF REVISION	REV BY DATE

REV	ECO	DESCRIPTION OF REVISION	REV BY	DATE
-----	-----	-------------------------	--------	------

ASSEMBLY, COOLANT HEATER CFP23E

DWG UNITS: IN/LB/S
SCALE: 0.210
EST WEIGHT: 113.480

DRAWN BY: PBS
PRO-ENGINEER

DATE: 16NOV2016
INIT ECO: 2016-668

SHEET 1 OF 1
DRAWING NO: A042J192

BILL OF MATERIAL			
ITEM	QTY	DESCRIPTION	PART NUMBER
1	1	HARNES,WIRE,ECM A/B, CFP23E, FPDP GEN 2	A042H301
2	1	HARNES,WIRE,PWR/INTERFACE, CFP23E,FPDP GEN 2	A042H302
3	1	HARNES,WIRE,SENSOR/ACTUATOR, CFP23E, FPDP GEN 2	A042J135
4	1	HARNES, SPEED SENSOR EXTENSION, CFP23E	13972
5	1	KIT, LOOSE WIRE, CFP23E/CFP30E	23939
6	1	SENSOR,ENGINE SPEED	4327239
7	2	SENSOR,PRESSURE	4921499

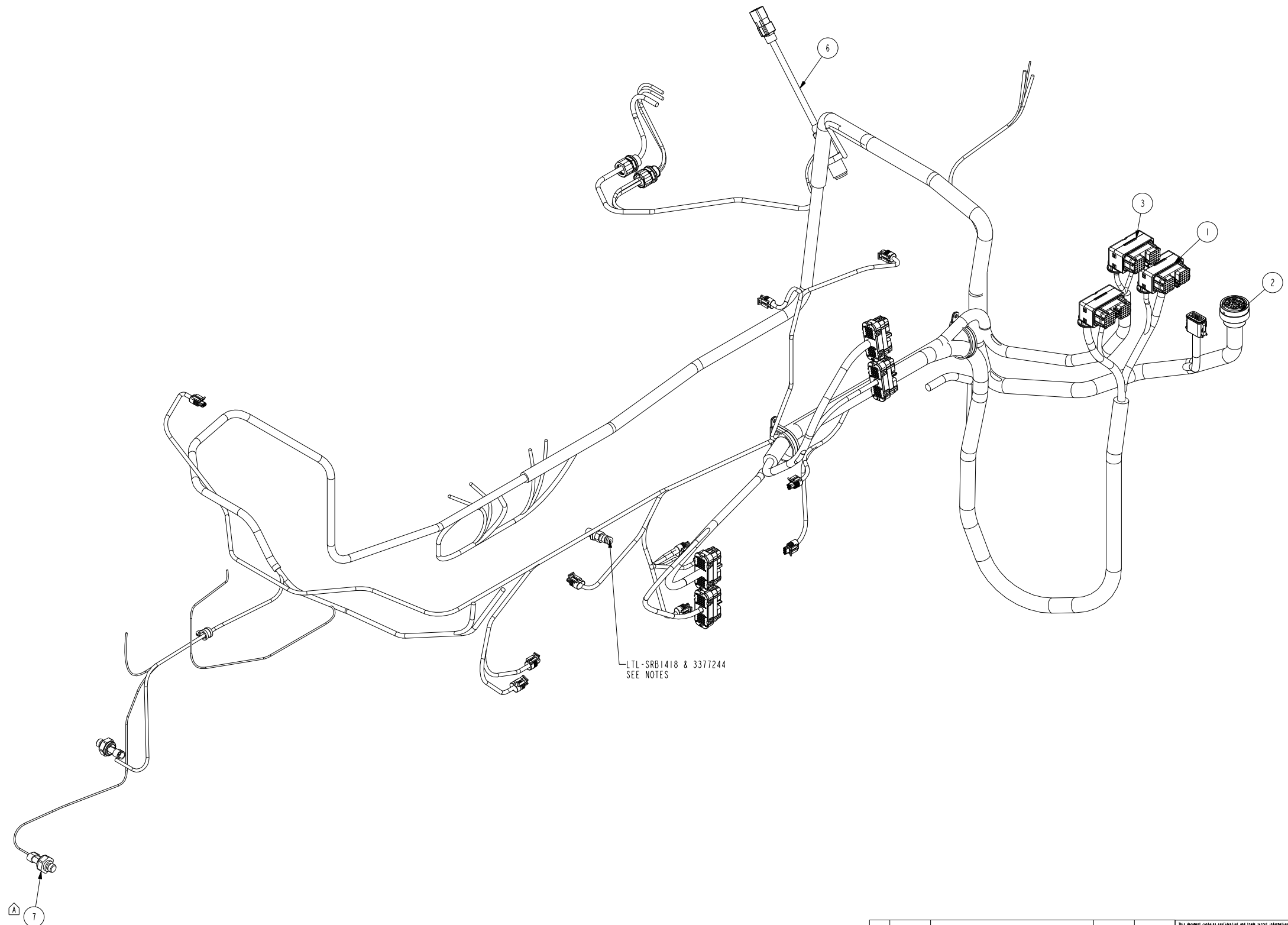

NOTES:
 1) DYNO TESTING ONLY: REMOVE PLUG FROM OIL GALLEY ON LEFT SIDE OF ENGINE AND KEEP FOR FUTURE USE. INSTALL LTL-SRB1418 & 3377244 TO DYNO TEST. WHEN FINISHED, REMOVE FITTINGS AND REPLACE WITH REMOVED PLUG. STORE LTL-SRB1418 & 3377244 FITTINGS FOR FUTURE USE IN TEST CELL AREA.

LTL-SRB1418 & 3377244
 SEE NOTES

<p>This document contains confidential and trade secret information, is the property of Cummins Power LLC and is loaned to the recipient in confidence. The recipient, by receiving and retaining this document, agrees to maintain the confidentiality of trade secret information therein. If you copy, the document, or its contents, in whole or in part, for any purpose other than that intended by Cummins Power LLC, you are in violation of the terms of this document, and you shall be liable for any damages, including reasonable attorneys' fees and costs of litigation, that may be incurred by Cummins Power LLC.</p>		<p>ASSEMBLY, SENSOR & HARNESSING CFP23E</p>	
<p>UNLESS OTHERWISE SPECIFIED ALL DIMENSION TOLERANCES ARE</p>		<p>DATE: 25JAN2017</p>	
<p>ANGULAR DIMENSIONS ± 1°</p>		<p>DWG UNITS: in/lb/s</p>	
<p>FINED ANGLE PROJECTION</p>		<p>PRO-ENGINEER</p>	
<p>125</p>		<p>SCALE: 0.280</p>	
<p>REV A 2017-137 ADD 4921499</p>		<p>EST WEIGHT: 0.000</p>	
<p>ECO DESCRIPTION OF REVISION</p>		<p>SHEET 1 OF 2</p>	
<p>REV BY DATE</p>		<p>DRAWING NO: A042H300</p>	

CUMMINS CONFIDENTIAL

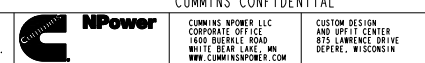

CUSTOM DESIGN AND UPFIT CENTER 875 LAWRENCE DRIVE DEPERE, WISCONSIN

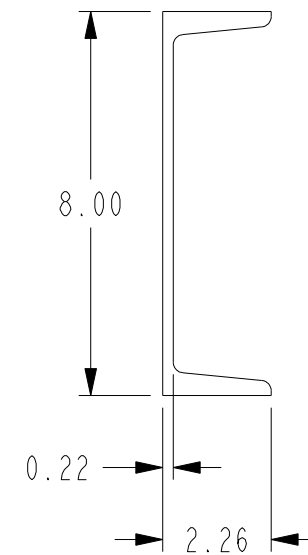
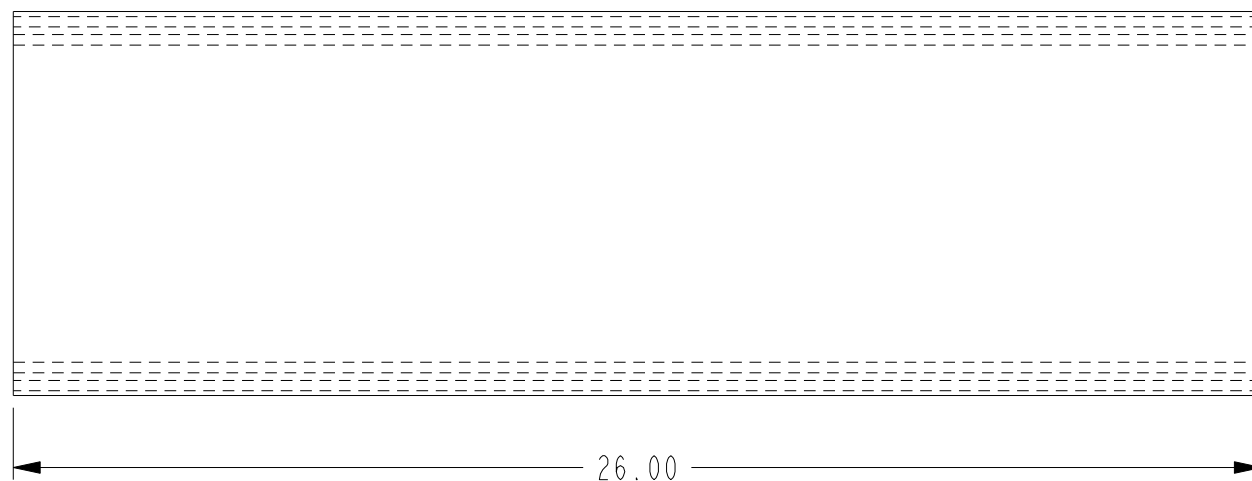

- NOTES:
 1. MATERIAL: CHANNEL, C8 x 11.5 ASTM A-36 STEEL
 2. FINISH: NONE

This document contains confidential and trade secret information, is the property of Cummins Fire Power LLC and is given to the receiver in confidence. The receiver, by receiving and retaining of the document accepts the document in confidence and agrees that, except as authorized in writing by Cummins NPower, it will (1) not use the document or any copy thereof or the confidential or trade secret information therein, (2) not copy the document, (3) not disclose to others either the document or the confidential or trade secret information therein, and (4) upon completion of the need to retain the document, or upon demand, return the document, all copies thereof, and all material copied therefrom. COPYRIGHT Cummins Fire Power LLC



CUMMINS FIRE POWER LLC
 CORPORATE OFFICE
 1600 BUERKLE ROAD
 WHITE BEAR LAKE, MN
 WWW.CUMMINSFIREPOWER.COM

CUSTOM DESIGN
 AND UPFIT CENTER
 875 LAWRENCE DRIVE
 DEPERE, WISCONSIN

UNLESS OTHERWISE SPECIFIED ALL DIMENSION TOLERANCES ARE

ANGULAR DIMENSIONS ± 1°	MACHINED SURFACES	IMPERIAL UNITS	METRIC UNITS
THIRD ANGLE PROJECTION	125	MACHINE TOLERANCES .XX = ± 0.010 .XXX = ± 0.005	MACHINE TOLERANCES .X = ± 0.4 .XX = ± 0.2
		FORM TOLERANCES .XX = ± 0.030 .XXX = ± 0.015	FORM TOLERANCES .X = ± 0.8 .XX = ± 0.4
		FAB TOLERANCES .XX = ± 0.060 .XXX = ± 0.030	FAB TOLERANCES .X = ± 1.5 .XX = ± 0.8

CHANNEL, END		DWG UNITS:	DRAWN BY: PBS	DATE: 31MAR2016
		SCALE: 0.250		INIT ECO: 2015-610
		EST WEIGHT: 24.905	SHEET 1 OF 1	DRAWING NO: A042G636

REV	ECO	DESCRIPTION OF REVISION	REV BY	DATE

BILL OF MATERIAL

ITEM	QTY	DESCRIPTION	PART NUMBER
1	1	MOUNT, OPERATOR STATION, CFP CONTROL PANEL	22318
2	2	ISOLATOR, PLATE MOUNT, 3 LB (YELLOW MARK)	15400
3	2	ISOLATOR, PLATE MOUNT, 6 LB (RED MARK)	15412
4	12	RIVET, ALUMINUM, STEEL SHANK, 0.156 DIA, 0.25-0.38 GRIP	15414
5	2	FENDER WASHER, 0.281 X 1.25	15421
6	4	SCREW, SELF LOCKING, 0.25-20 X 1.00, PH OR BH	15422

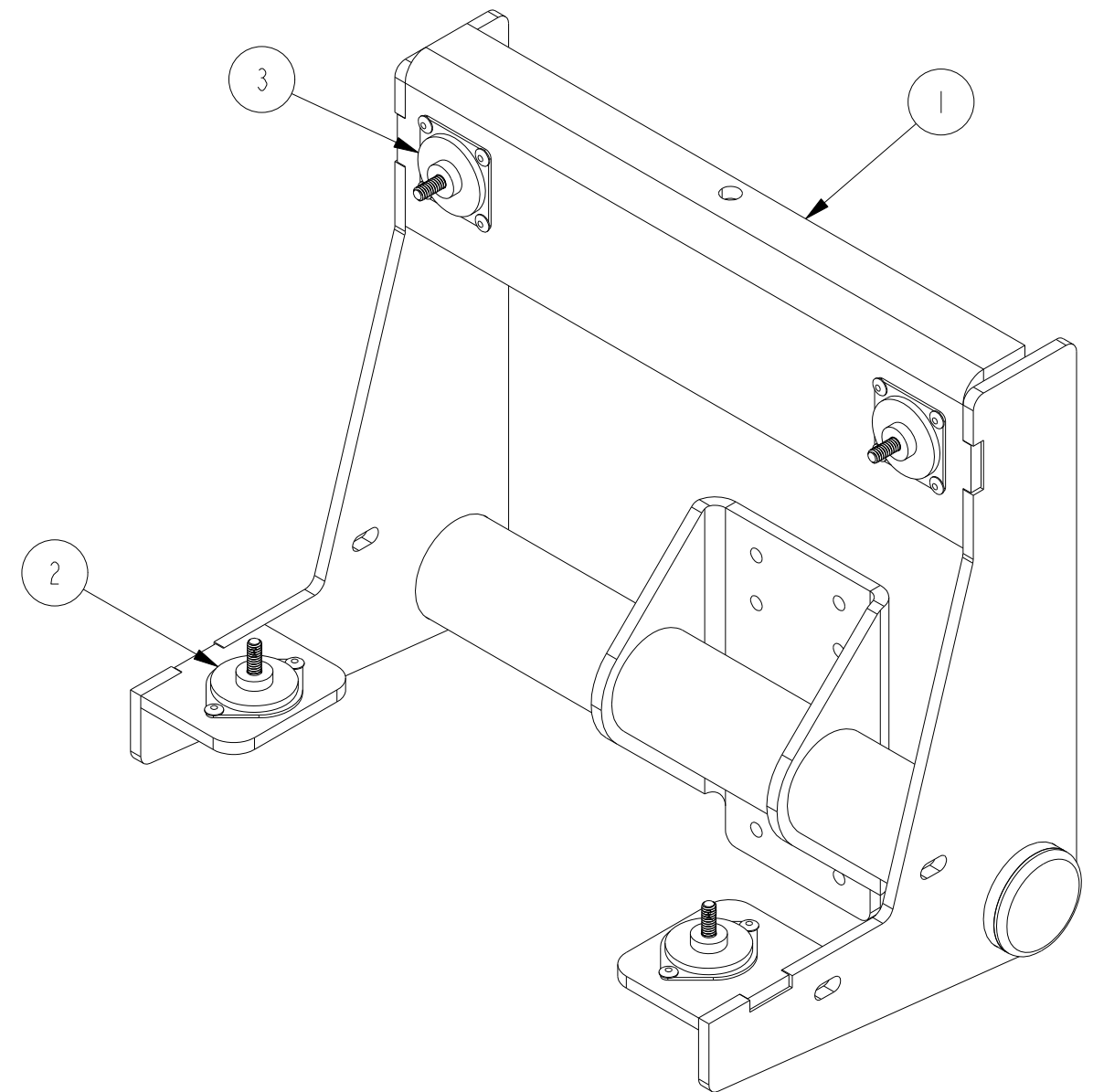
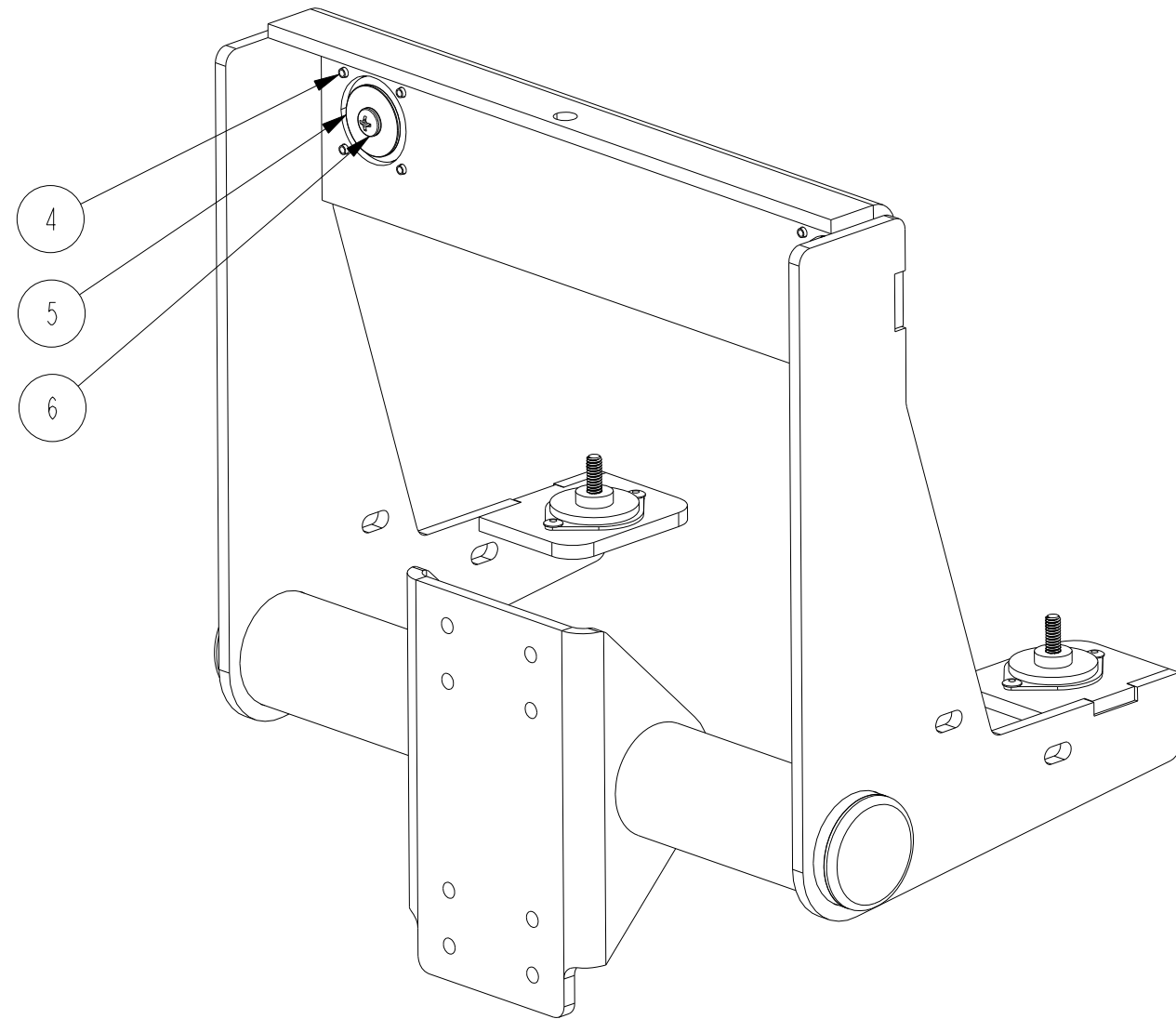

This document contains confidential and trade secret information, is the property of Cummins Fire Power LLC and is given to the receiver in confidence. The receiver, by receiving and retaining of the document accepts the document in confidence and agrees that, except as authorized in writing by Cummins NPower, it will (1) not use the document or any copy thereof or the confidential or trade secret information therein, (2) not copy the document, (3) not disclose to others either the document or the confidential or trade secret information therein, and (4) upon completion of the need to retain the document, or upon demand, return the document, all copies thereof, and all material copied therefrom. COPYRIGHT Cummins Fire Power LLC



CUMMINS FIRE POWER LLC
CORPORATE OFFICE
1600 BUERKLE ROAD
WHITE BEAR LAKE, MN
WWW.CUMMINSFIREPOWER.COM

CUSTOM DESIGN
AND UPFIT CENTER
875 LAWRENCE DRIVE
DEPERE, WISCONSIN

UNLESS OTHERWISE SPECIFIED ALL DIMENSION TOLERANCES ARE

ANGULAR DIMENSIONS ± 1°	MACHINED SURFACES	IMPERIAL UNITS	METRIC UNITS
THIRD ANGLE PROJECTION	125	MACHINE TOLERANCES .XX ± 0.010 .XXX ± 0.005	MACHINE TOLERANCES .X ± 0.4 .XX ± 0.2
		FORM TOLERANCES .XX ± 0.030 .XXX ± 0.015	FORM TOLERANCES .X ± 0.8 .XX ± 0.4
		FAB TOLERANCES .XX ± 0.060 .XXX ± 0.030	FAB TOLERANCES .X ± 1.5 .XX ± 0.8

ASSEMBLY, CONTROL PANEL MOUNTING
CFP POWER UNITS

DWG UNITS: IN/LB/S	DRAWN BY: S DUBICK PRO-ENGINEER	DATE: 26-SEP-12 INIT ECO: 2012-392
SCALE: 0.333	SHEET 1 OF 1	DRAWING NO: 21249
EST WEIGHT: 16.439		

REV	ECO	DESCRIPTION OF REVISION	REV BY	DATE

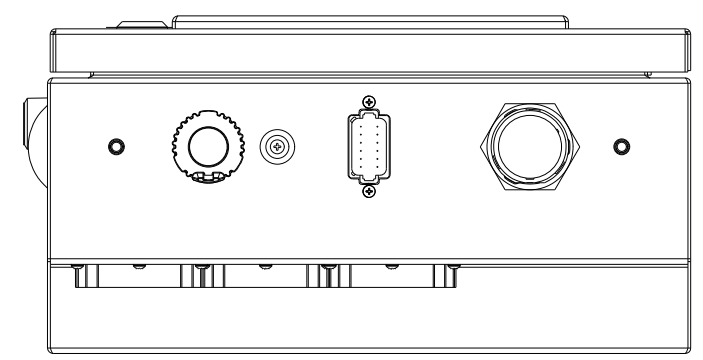
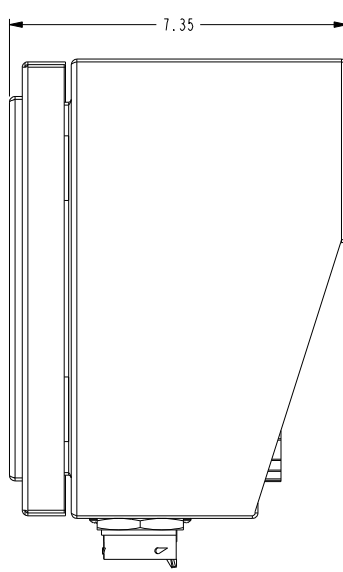
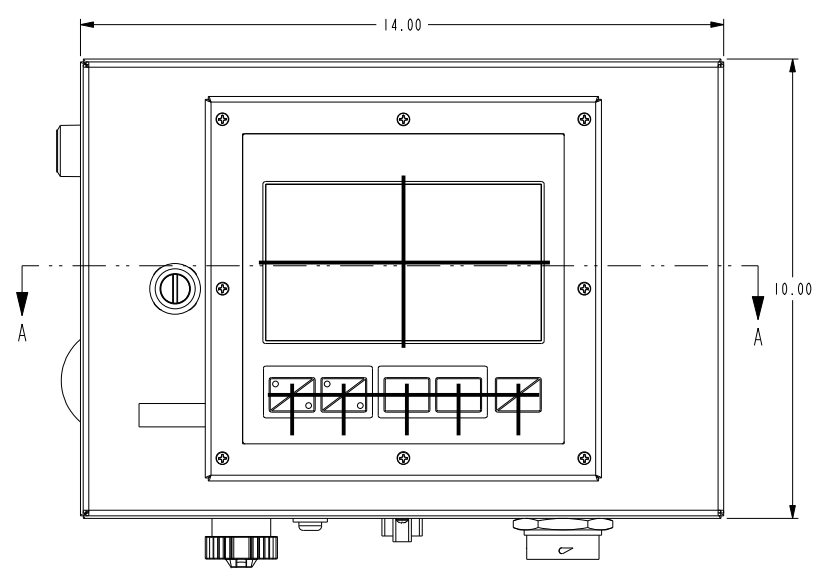
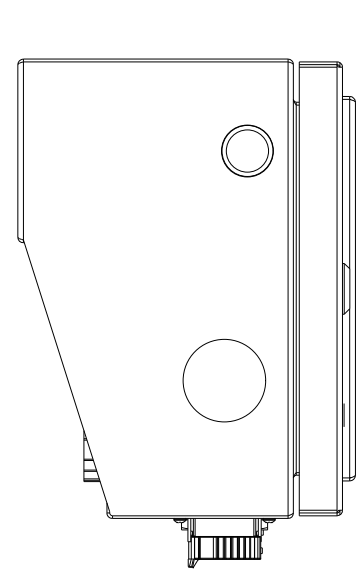
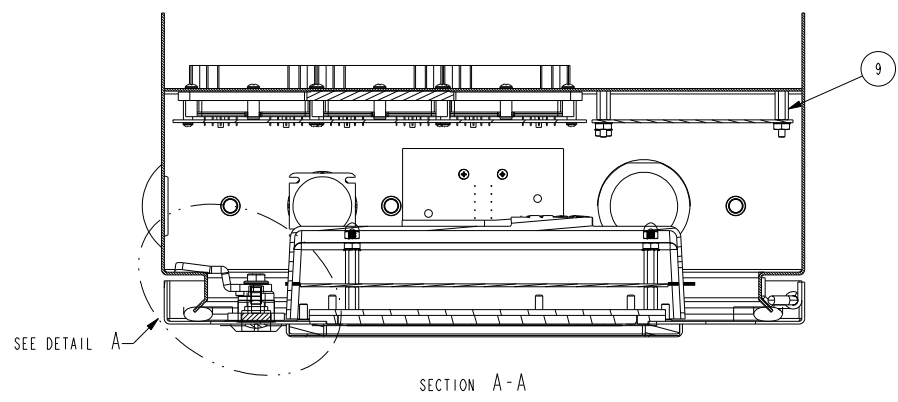
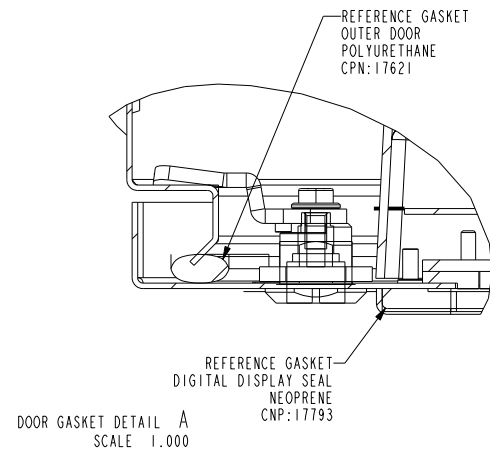

BILL OF MATERIAL			
ITEM	QTY	DESCRIPTION	PART NUMBER
1	1	POWER MODULE ECM , DIGITAL PANEL, ELECTRONIC	15155
2	1	ASSY, WIRING, DIGITAL PANEL, ENGINE STOP SWITCH	15160
3	1	DIAGNOSTICS, DIGITAL PANEL, RECEPTACLE AND CABLE	A042G193
4	1	ASSY,BULKHEAD WIRING, DIGITAL PANEL, BULKHEAD TO POWER PCB	A042G197
5	1	CABLE, DIGITAL PANEL, POWER PCB TO DISPLAY PCB	A042G198
6	1	SWITCH PCB, DIGITAL PANEL, MODULE, ECM	A042G207
7	1	CABINET, CONTROL PANEL	A042H232
8	1	BEZEL, FORMED, STEEL, CONTROL PANEL	15165
9	9	STANDOFF HEX M/F, 8-32, BRASS .63"L	15579
10	6	STANDOFF HEX M/F, 8-32, BRASS .75"L	15580
11	14	NUT, 8-32, W/TOOTH WASHER, ZNC -PLTD	15582
12	1	PLUG, LIQUID TIGHT, HEYCO, 3B37	15645
13	4	NUT, ACORN, SELF-LOCKING, 8-32, 18-8 STNL STL	17149
14	2	STANDOFF HEX M/F, 8-32, BRASS 1.25"L	17205
15	1	BEZEL, GASKET 1/4" x 3/4"	17793
16	1	TIE, WIRE, 4", NATURAL	3M101M-ND
17	1	SCREW, 1/4-20 STAINLESS STEEL	91772A537
18	1	WASHER, 1/4" STAINLESS STEEL	93852A102
19	8	SCREW, 6-32, 1/2" LONG , STAINLESS STEEL, BLACK OXIDE FINISH	96640A117
20	20	SCREW, 8-32, 1/2" LONG , STAINLESS STEEL	99461A240
21	1	MEMBRANE, KEYPAD	A042G192
22	1	COVER, DOOR PANEL	A042G194
23	1	PCB, DIGITAL PANEL, ELECTRONIC	A042G195
24	1	POWER PCB, DIGITAL PANEL, ELECTRONIC	A042G196
25	1	DISPLAY, COLOR TOUCH SCREEN	A042G199
26	1	STRAP, GROUND	A042G200
27	1	CABLE, DIGITAL PANEL, POWER PCB TO ECM SWITCH PCB	A042G202
28	1	LABEL, UL , ELECTRONIC CONTROL PANEL	A042G204
29	1	BEZEL, DISPLAY MOUNTING, FIRE PUMP DIGITAL PANEL	A042H037
30	1	COVER, DISPLAY, FIRE PUMP DIGITAL PANEL	A042H565
31	1	SWITCH, PUSHBUTTON, ABB CONTROL, CP110R-01	CP110R-01
32	1	CLIP, RIBBON CABLE, 25.6mm	FCM1-A-C14
33	1	COVER, HD10 W/LANYARD, DEUTSCH	HDC16-9-E004-L47N
34	1	HOLDER, TIE, ADHESIVE, NATURAL	RP302-ND

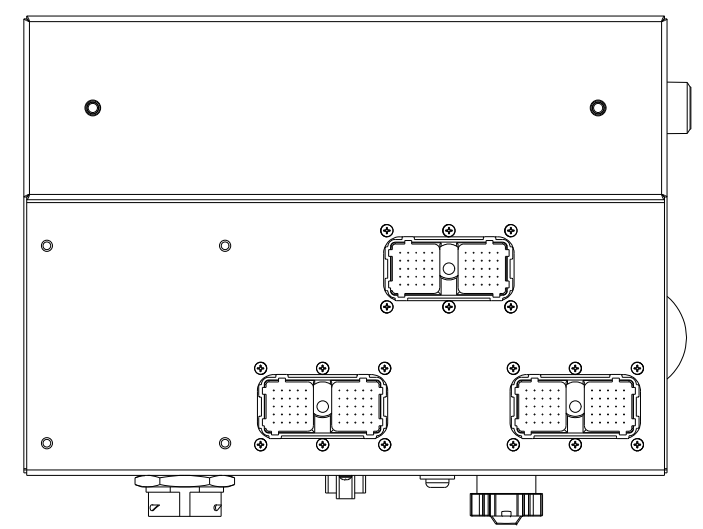

NOTES:
1. TYPE 4X INDOOR USE CONSTRUCTION
2. UPDATED SOFTWARE

This document contains confidential and trade secret information, is the property of Cummins Fire Power LLC and is to be used only for the intended purpose. The recipient of this document is authorized to use the information contained herein for the intended purpose only. Any other use, including copying, distribution, or disclosure, is strictly prohibited. If you are not the intended recipient, you should not disseminate, distribute, or copy this document. If you have received this document in error, please notify the sender immediately by e-mail at firepower@cumminsfirepower.com or by phone at 1-800-368-5777. Thank you for your cooperation.

Fire Power
CUMMINS FIRE POWER LLC
CORPORATE OFFICE
1600 BLUEBELL ROAD
WHITE BEAR LAKE, MN
WWW.CUMMINSFIREPOWER.COM

CUSTOM DESIGN
AND UPFIT CENTER
875 LAWRENCE DRIVE
DEPERE, WISCONSIN

UNLESS OTHERWISE SPECIFIED ALL DIMENSION TOLERANCES ARE		ANGULAR DIMENSIONS ± 1°		MACHINED SURFACES		IMPERIAL UNITS		METRIC UNITS		DWG UNITS:		DRAWN BY: PBS		DATE: 14SEP2016	
						IN/LB/S		IN/LB/S		SCALE: 0.500		SHEET 1 OF 2		INIT ECO: 2016-376	
REV A		2017-057		UPDATED PER A042H232		PBS		01FEB2017		EST WEIGHT: 28.994		DRAWING NO: A042G185			
REV ECO				DESCRIPTION OF REVISION		REV BY		DATE							

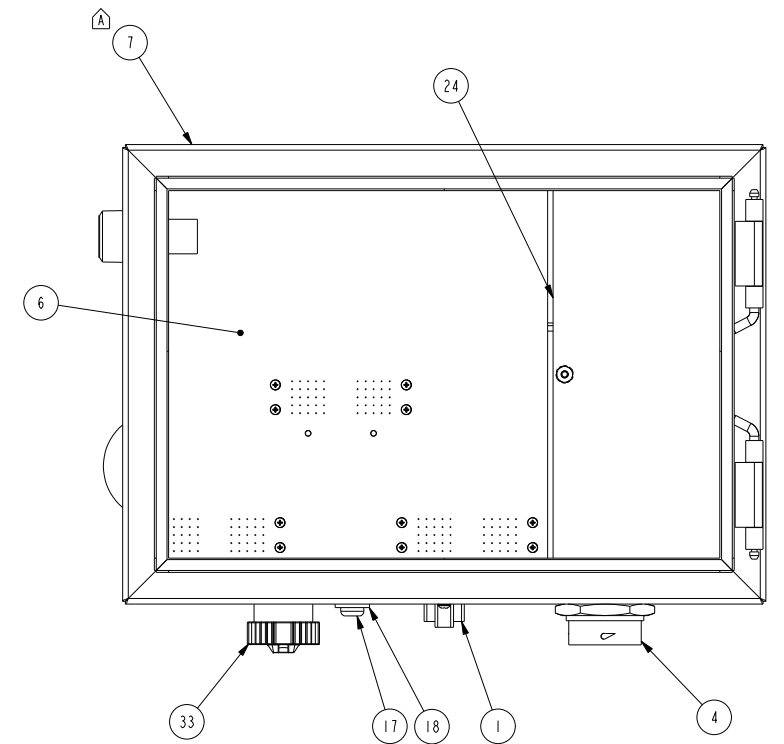
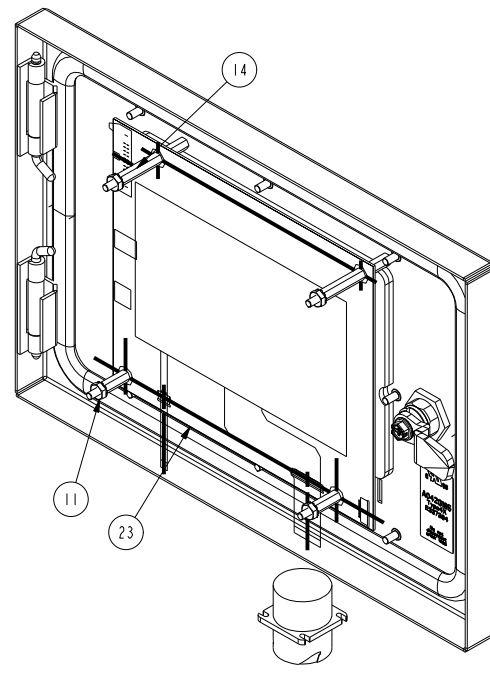
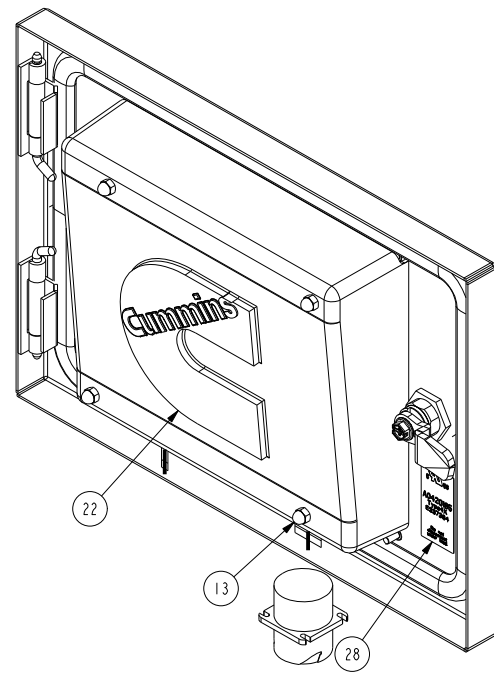
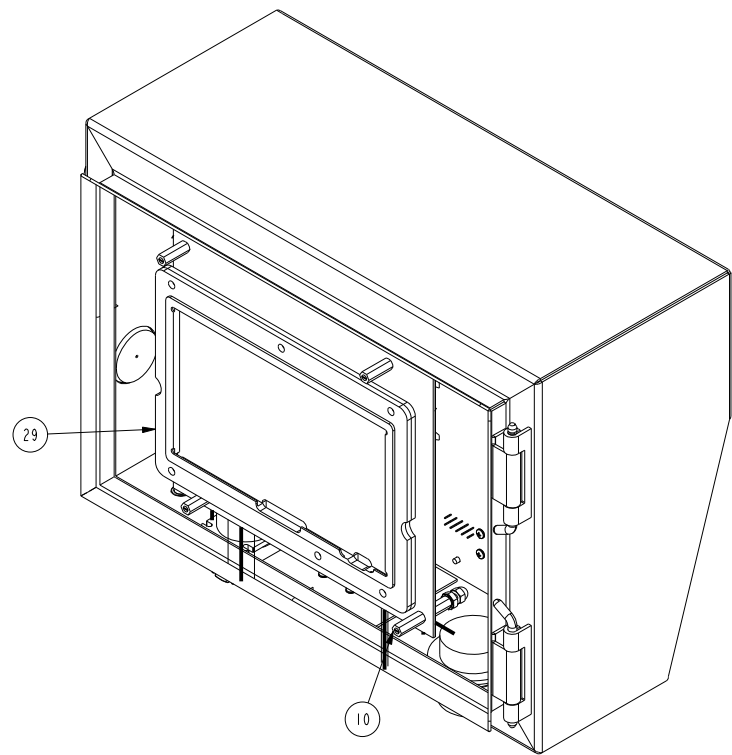
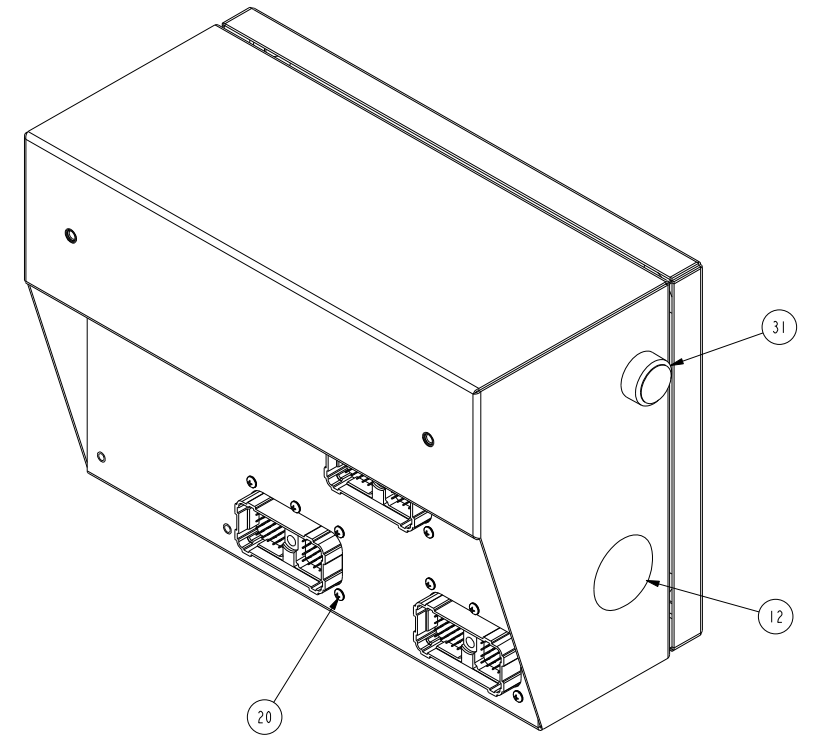
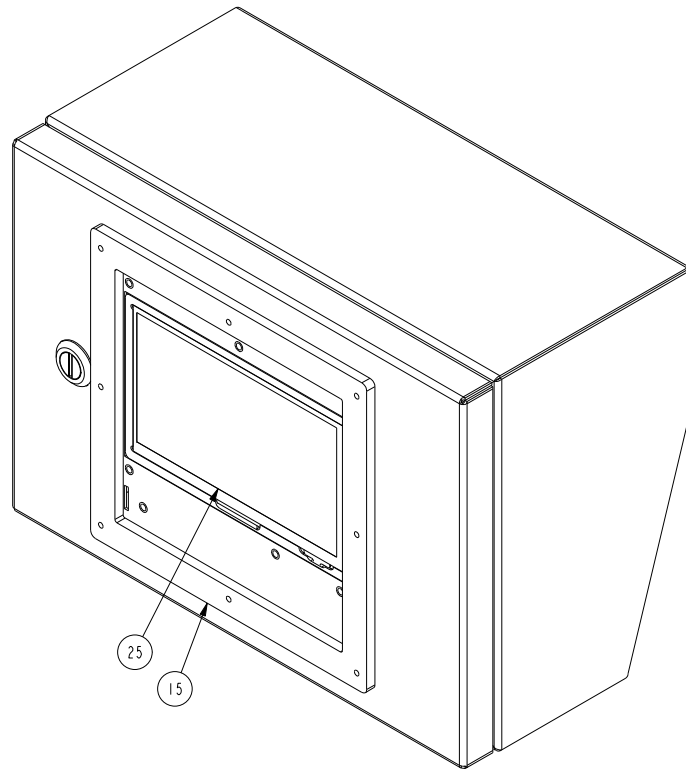
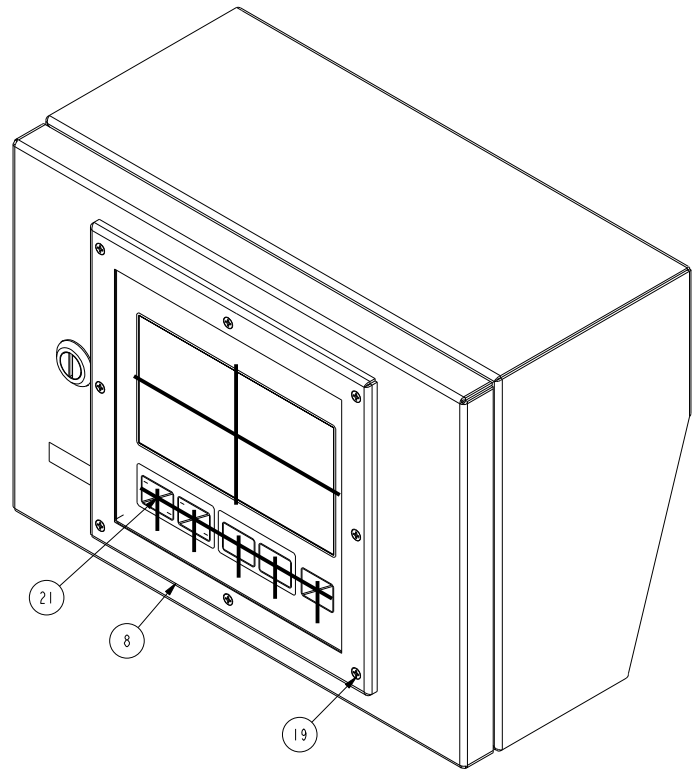

This document contains confidential and trade secret information, is the property of Cummins Fire Power, LLC and is loaned to the recipient for use only in connection with the project for which it is loaned. It is not to be distributed, copied, or otherwise used for any other purpose without the express written consent of Cummins Fire Power, LLC. If you are not the intended recipient, you should not disseminate, distribute or take any action in reliance on the contents hereof. If you have received this document in error, please notify the sender immediately by e-mail at corporate@firepower.com or by phone at 800.368.5273. This document is not intended to constitute an offer of insurance or any other financial product. For more information, please contact your broker or agent.

UNLESS OTHERWISE SPECIFIED ALL DIMENSION TOLERANCES ARE ANGULAR DIMENSIONS ± 1° MACHINED SURFACES ± 0.005" IMPERIAL METRIC SURFACES ± 0.125mm

125

Fire Power
CUMMINS FIRE POWER LLC
CORPORATE OFFICE
1600 BUECKLE ROAD
WHITE BEAR LAKE, WI
WWW.CUMMINSFIREPOWER.COM

ASSEMBLY, DIGITAL CONTROL PANEL
ELECTRONIC CFP ENGINES

DWG UNITS: IN/LB/S
SCALE: 0.500
EST WEIGHT: 28.994

DRAWN BY: PBS
PRO-ENGINEER
SHEET 2 OF 2

DATE: 14SEP2016
INIT ECO: 2016-376
DRAWING NO: A042G185

REV	ECO	DESCRIPTION OF REVISION	REV BY	DATE
A	2017-057	SEE SHEET 1 FOR LATEST REVISION DETAILS	PBS	01FEB2017

BILL OF MATERIAL

ITEM	QTY	DESCRIPTION	PART NUMBER
1	1	CONTACTOR, MANUAL OVERRIDE, 12V, PN:535-0127, FIREPUMP	8824-12
2	1	CONTACTOR, MANUAL OVERRIDE, 24V, PN:535-0098, FIREPUMP	8824-24

1 2 3 4 5 6 7

PRO0010

DESIGN APPROVAL DATE UNspecified TOLERANCES
 DES.ENG. JOK ±.005
 MFG.ENG. JOK ±.010
 Q.C. JOK Machine Finish ±.050
 SALES JOK Angles ±1°
 Concentricity .005 TIR
 Squareness .001 per ft.

This Drawing is the property of the Dumore Corporation. It must not be reproduced or copied without written permission.

PART NO. 535-0127
DUMORE CORPORATION
 1030 VETERANS ST. MAUSTON, WI 53948

DO NOT SCALE DRAWING REMOVE ALL BURRS BREAK SHARP CORNERS TITLE ASSEMBLY, SOLENOID

MATERIAL SPEC: Rec. per Piece Pattern No. RECEIVED AS DWG. BY CTH DATE 7/19/01 SCALE 1:2

REVISIONS
 RELEASED ECN # 25159 7/19/01 CTH

THE 535-0127 SOLENOID ASSEMBLY MUST BE INSTALLED IN A NEMA 2 ENVIRONMENT

ELECTRICAL SPECIFICATIONS
 VOLTS: 12 VDC
 CONTACT RATING: 400 AMPS (ROLLING CURRENT)
 800 AMPS (BREAKAWAY CURRENT)
 DUTY TYPE: INTERMITTENT
 CONTACT POSITION: NORMALLY OPEN

WHERE USED

3.00 ± .06
 2.34 ± .03
 17° - 20°
 5.74
 2.65 ± .03
 .275
 .255 TYP (4)
 .50 1.75
 6.00 ± .03

30° 30°
 10-32 UNF-2A THREAD TYP.(2)
 3/8-16 UNC-2A THREAD TYP.(2)
 U.L. & FACTORY MUTUAL DECAL.
 1.99 ± .03 TYP.
 1.90
 .354
 .334
 1.50
 3.00
 3.63 ± .03
 4.88 ± .06
 .28

ITEM:1 - 8824-12

1 2 3 4 5 6 7

SP4847

DESIGN APPROVAL DATE UNspecified TOLERANCES
 DES.ENG. JOK ±.005
 MFG.ENG. JOK ±.010
 Q.C. JOK Machine Finish ±.050
 SALES JOK Angles ±1°
 Concentricity .005 TIR
 Squareness .001 per ft.

This Drawing is the property of the Dumore Corporation. It must not be reproduced or copied without written permission.

PART NO. 535-0098
DUMORE CORPORATION
 1030 VETERANS ST. MAUSTON, WI 53948

DO NOT SCALE DRAWING REMOVE ALL BURRS BREAK SHARP CORNERS TITLE ASSEMBLY, SOLENOID

MATERIAL SPEC: Rec. per Piece Pattern No. RECEIVED AS DWG. BY MED DATE 2/16/89 SCALE 1:2
 Q.C. BY RS DATE 8/13/91

REVISIONS

THE 535-0098 SOLENOID ASSEMBLY MUST BE INSTALLED IN A NEMA 2 ENVIRONMENT

ELECTRICAL SPECIFICATIONS
 VOLTS: 24 VDC
 CONTACT RATING: 400 AMPS (ROLLING CURRENT)
 800 AMPS (BREAKAWAY CURRENT)
 DUTY TYPE: INTERMITTENT
 CONTACT POSITION: NORMALLY OPEN

3.00 ± .06
 2.34 ± .03
 17° - 20°
 5.74
 2.65 ± .03
 .275
 .255 TYP (4)
 .50 1.75
 6.00 ± .03

30° 30°
 10-32 UNF-2A THREAD TYP.(2)
 3/8-16 UNC-2A THREAD TYP.(2)
 U.L. & FACTORY MUTUAL DECAL.
 1.99 ± .03 TYP.
 1.90
 .354
 .334
 1.50
 3.00
 3.63 ± .03
 4.88 ± .06
 .28

ITEM:2 - 8824-24

This document contains confidential and trade secret information, is the property of Cummins Fire Power LLC and is given to the receiver in confidence. The receiver, by receiving and retaining of the document accepts the document in confidence and agrees that, except as authorized in writing by Cummins Fire Power, it will (1) not use the document or any copy thereof or the confidential or trade secret information therein, (2) not copy the document, (3) not disclose to others either the document or the confidential or trade secret information therein, and (4) upon completion of the need to retain the document, or upon demand, return the document, all copies thereof, and all material copied therefrom. COPYRIGHT Cummins Fire Power LLC

Cummins Fire Power

CUMMINS FIRE POWER LLC
 CORPORATE OFFICE
 1600 BUERKLE ROAD
 WHITE BEAR LAKE, MN
 WWW.CUMMINSFIREPOWER.COM

CUSTOM DESIGN AND UPFIT CENTER
 875 LAWRENCE DRIVE
 DEPERE, WISCONSIN

MANUAL SOLENOID

UNLESS OTHERWISE SPECIFIED ALL DIMENSION TOLERANCES ARE -

ANGULAR DIMENSIONS ± 1°	IMPERIAL UNITS	METRIC UNITS
THIRD ANGLE PROJECTION	MACHINE TOLERANCES .XX ± 0.010 .XX ± 0.005 FOM TOLERANCES .XX ± 0.020 .XX ± 0.015 FAB TOLERANCES .XX ± 0.050 .XX ± 0.030	MACHINE TOLERANCES .XX ± 0.2 .XX ± 0.1 FOM TOLERANCES .XX ± 0.4 .XX ± 0.3 FAB TOLERANCES .XX ± 0.8 .XX ± 0.6

DWG UNITS: IN/LB/S	DRAWN BY: CMC	DATE: 12JUNE2004
SCALE: 1.000	PRO-ENGINEER	INIT ECO: -
EST WEIGHT: 42238.628	SHEET 1 OF 1	DRAWING NO: 8824

REV	ECO	DESCRIPTION OF REVISION	REV BY	DATE
A	2011-068	UPDATED DRAWING FORMAT ADDED CNP LABEL TO PDF DRAWING	MAC	18FEB2011

BILL OF MATERIAL

ITEM	QTY	DESCRIPTION	PART NUMBER
1	1	HOSE, FUEL, ENG-COOLER, CFP23E	23342
2	1	HOSE, FUEL, ECM-COOLER, CFP23E	23343
3	2	FUEL LINE, 24" EXTENSION, #16 FEM JIC X #16 221FR X 1" NPT	23496-016

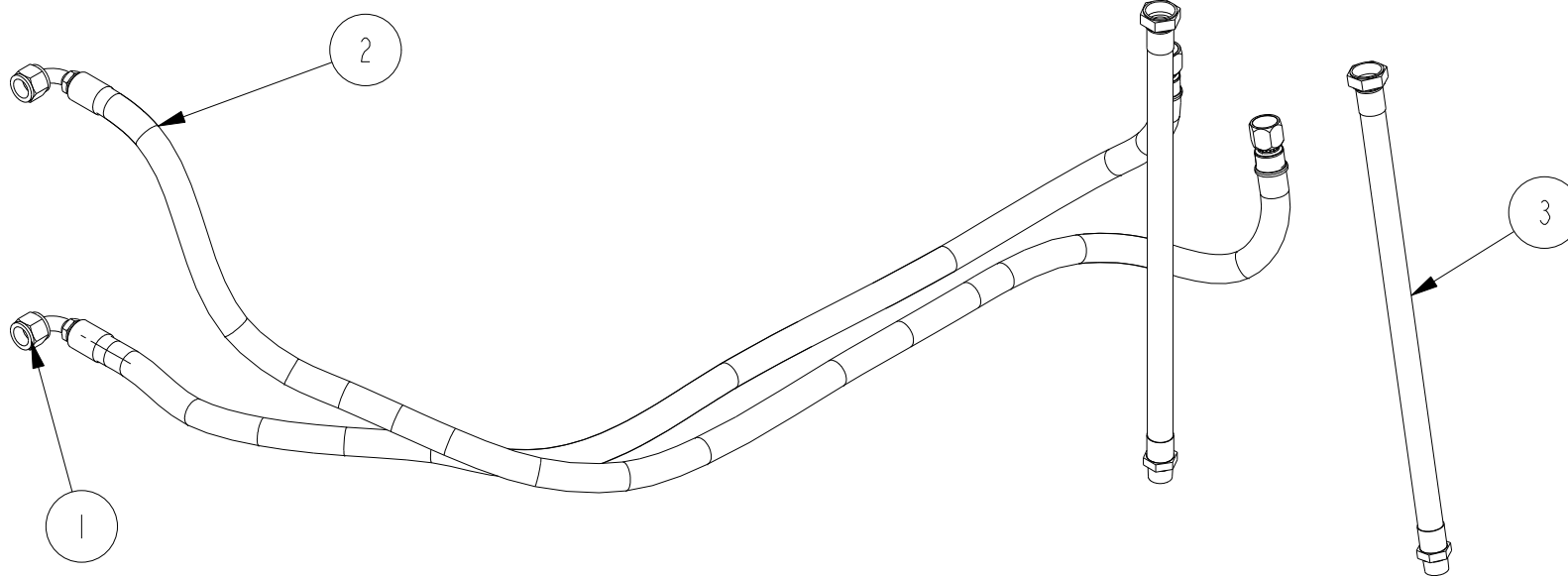

This document contains confidential and trade secret information, is the property of Cummins Fire Power LLC and is given to the receiver in confidence. The receiver, by receiving and retaining of the document accepts the document in confidence and agrees that, except as authorized in writing by Cummins Fire Power, it will (1) not use the document or any copy thereof or the confidential or trade secret information therein, (2) not copy the document, (3) not disclose to others either the document or the confidential or trade secret information therein, and (4) upon completion of the need to retain the document, or upon demand, return the document, all copies thereof, and all material copied therefrom. COPYRIGHT Cummins Fire Power LLC



CUMMINS FIRE POWER LLC
CORPORATE OFFICE
1600 BUERKLE ROAD
WHITE BEAR LAKE, MN
WWW.CUMMINSFIREPOWER.COM

CUSTOM DESIGN
AND UPFIT CENTER
875 LAWRENCE DRIVE
DEPERE, WISCONSIN

UNLESS OTHERWISE SPECIFIED
ALL DIMENSION TOLERANCES ARE

ANGULAR DIMENSIONS $\pm 1^\circ$

MACHINED SURFACES	IMPERIAL UNITS	METRIC UNITS
125	MACHINE TOLERANCES	MACHINE TOLERANCES
	.X ± 0.06	X ± 1.5
	.XX ± 0.010	XX ± 0.5
	.XXX ± 0.001	XXX ± 0.05
WELD TOLERANCES		WELDED TOLERANCES
.X ± 0.25		X ± 5
.XX ± 0.12		XX ± 3
.XXX ± 0.06		XXX ± 1.50

KIT, FUEL LINE
CFP23E

DWG UNITS:
IN/LB/S

DRAWN BY: PBS

PRO-ENGINEER

DATE: 04FEB2014

INIT ECO: 2014-071

EST WEIGHT: 15.233

SHEET

1 OF 1

DRAWING NO:

A042A380

REV	ECO	DESCRIPTION OF REVISION	REV BY	DATE

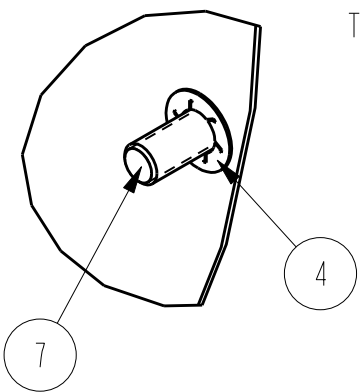

TYPICAL GUARDING FASTENERS
SCALE 0.500

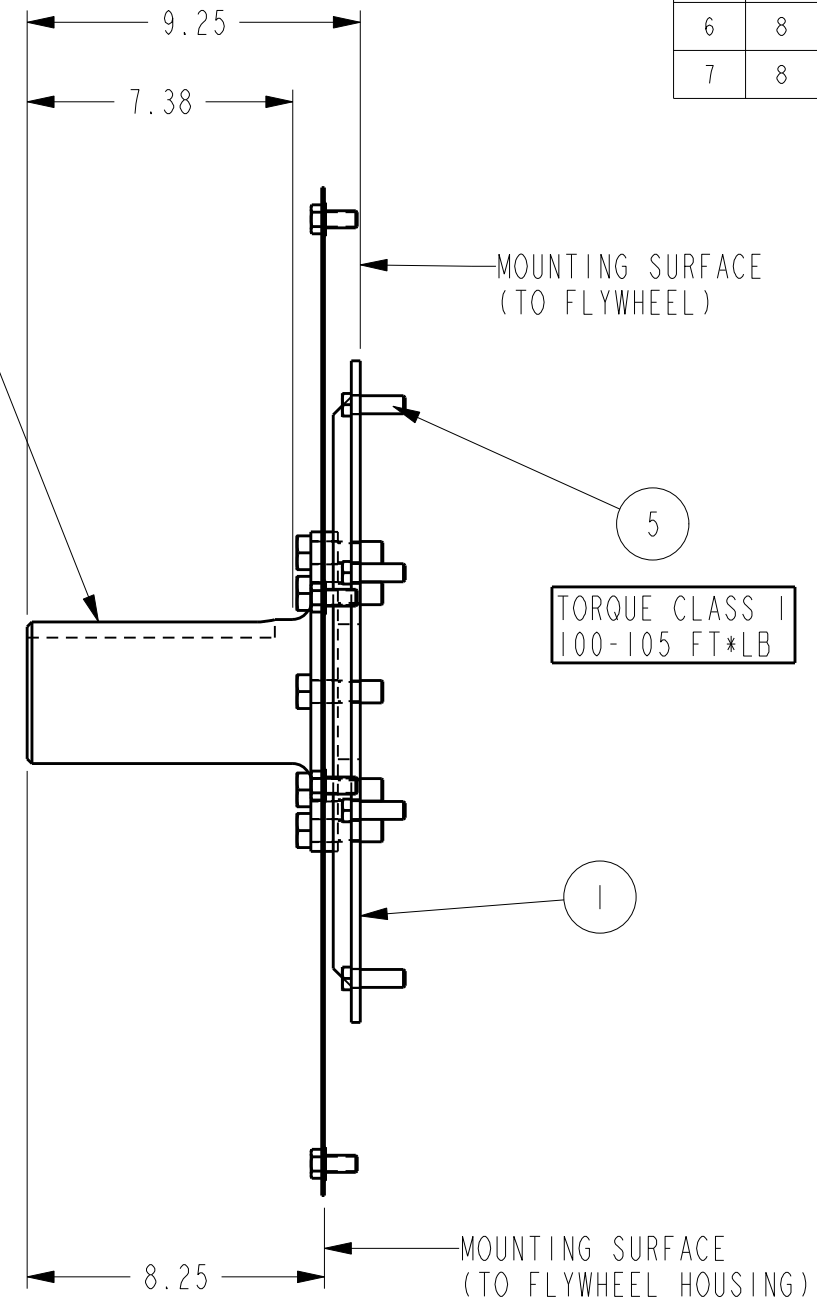
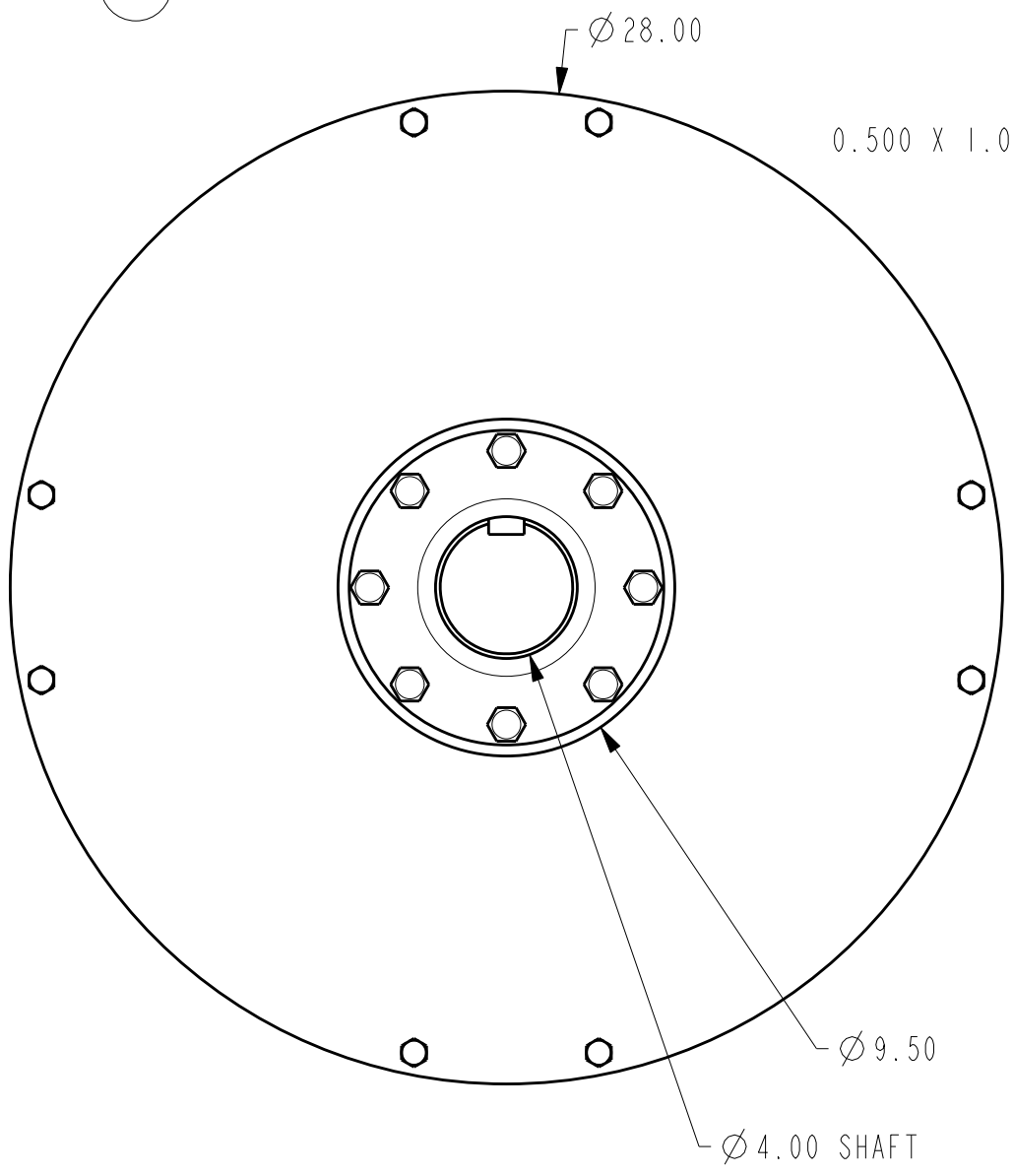

TORQUE CLASS 1
195-210 FT*LB

TORQUE CLASS 1
100-105 FT*LB

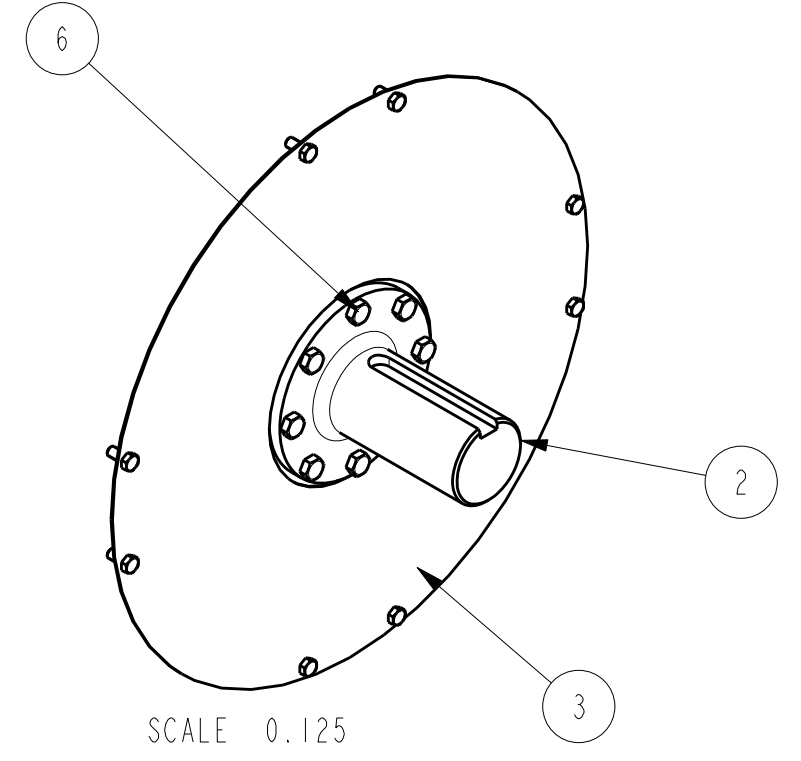

BILL OF MATERIAL			
ITEM	QTY	DESCRIPTION	PART NUMBER
1	1	ADAPTER, STUB SHAFT, SAE #1, CFP23E	13197
2	1	STUB SHAFT, 4" DIA. x 1" KEY, CFP23E	13198
3	1	GUARD, FLYWHEEL, SAE#0, CFP23E	13199
4	8	RETAINING WASHER, PUSHNUT, 1/2" BOLT	16662-08
5	8	SCREW, CAP, HEX HEAD, 1/2-13 UNC X 1.50"	HHCS_0500_0150
6	8	SCR,CAP,HEX,5/8-11 X 2.00, -	HHCS_0625_0200
7	8	HHCS m12 -1.75 X 25, COMMON HARDWARE	HHCS_M12_25

This document contains confidential and trade secret information, is the property of Cummins Fire Power LLC and is given to the receiver in confidence. The receiver, by receiving and retaining of the document accepts the document in confidence and agrees that, except as authorized in writing by Cummins NPower, it will (1) not use the document or any copy thereof or the confidential or trade secret information therein, (2) not copy the document, (3) not disclose to others either the document or the confidential or trade secret information therein, and (4) upon completion of the need to retain the document, or upon demand, return the document, all copies thereof, and all material copied therefrom. COPYRIGHT Cummins Fire Power LLC



CUMMINS FIRE POWER LLC
CORPORATE OFFICE
1600 BUERKLE ROAD
WHITE BEAR LAKE, MN
WWW.CUMMINSFIREPOWER.COM

CUSTOM DESIGN
AND UPFIT CENTER
875 LAWRENCE DRIVE
DEPERE, WISCONSIN

ASSEMBLY, STUB SHAFT
SAE #1 W/ 4.00" DIA SHAFT & GUARD

UNLESS OTHERWISE SPECIFIED ALL DIMENSION TOLERANCES ARE

ANGULAR DIMENSIONS ± 1° IMPERIAL UNITS METRIC UNITS

THIRD ANGLE PROJECTION	MACHINE TOLERANCES .XX ± 0.005 FOM TOLERANCES .XX ± 0.010 FAB TOLERANCES .XX ± 0.030	MACHINE TOLERANCES .XX ± 0.2 FOM TOLERANCES .XX ± 0.4 FAB TOLERANCES .XX ± 0.8
------------------------	---	---

DWG UNITS: IN/LB/S DRAWN BY: DAN DATE: 04-MAR-10

SCALE: 0.188 EST WEIGHT: 96.558 SHEET 1 OF 1 DRAWING NO: 16768

REV	ECO	DESCRIPTION OF REVISION	REV BY	DATE

FPDP GEN II

CS P/N A042G185
SS P/N A042G187

TO OVERLAY

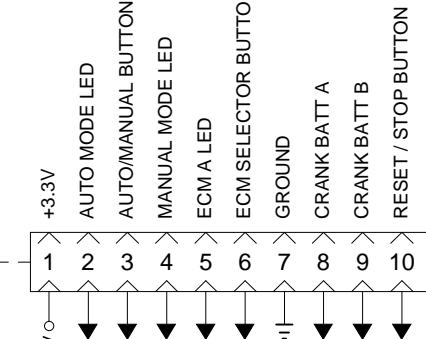

TO LCD TOUCHSCREEN

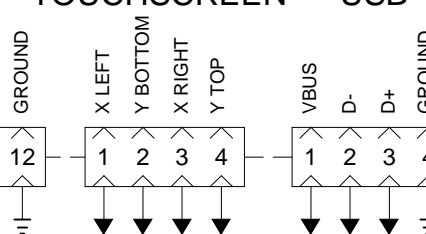

TO LCD



P/N A042G195 DISPLAY BOARD



P/N A042G207 ECM SWITCH BOARD

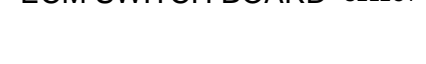

****SEE SHEETS 2 & 3 FOR REMAINDER OF ECM SWITCH BOARD SCHEMATIC****

TO ADDITIONAL SWITCH BOARDS

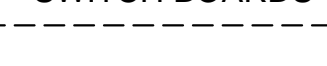

TO PUMP CONTROLLER



P/N A042G196 POWER BOARD



P/N A042C868

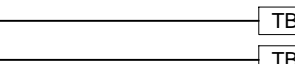

P/N A042H302

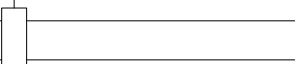

P/N 15155 ECM POWER BOARD



P/N A042J117

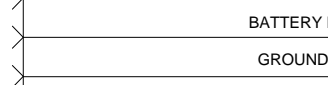

NOTE SEE SHEET 6 FOR BETTER VIEW OF POWER CIRCUITS

UNLESS OTHERWISE SPECIFIED ALL DIMENSION TOLERANCES ARE:

ANGULAR DIMENSIONS ± 1°	IMPERIAL UNITS	METRIC UNITS
0.005	0.005	0.125
0.010	0.010	0.250
0.015	0.015	0.375
0.020	0.020	0.500
0.030	0.030	0.750
0.040	0.040	1.000
0.050	0.050	1.250
0.060	0.060	1.500
0.070	0.070	1.750
0.080	0.080	2.000
0.090	0.090	2.250
0.100	0.100	2.500

THIRD ANGLE PROJECTION

SCALE: 1" = 1" (1:1)

EST WEIGHT:

CUMMINS NPower
CORPORATE OFFICE
1600 BUENLE ROAD
WHITE SEAS LAKE, ILL.
WWW.CUMMINSPOWER.COM

SHEMATICS, OVERALL, CFP23E
FPDP GEN II

DWG UNITS: INCH/LB/S
SCALE: 1" = 1" (1:1)
EST WEIGHT:

DRAWN BY: KAK
DATE: 22 NOV 2016
INIT ECO: 2016-694

CUSTOM DESIGN AND
UPFIT CENTER
875 LAWRENCE DRIVE
DEPERE, WISCONSIN

SHEET 1 OF 6 DRAWING NO: A042J126

A	2017-498	CHANGED FS0 DIODE MOUNT POSITION TO POSITION 1 AND CHANGED FS5 DIODE RETURN TO POSITION 2	TJB	4AUG2017
REV	ECO	DESCRIPTION OF REVISION	BY	DATE

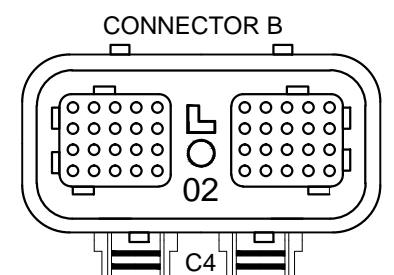
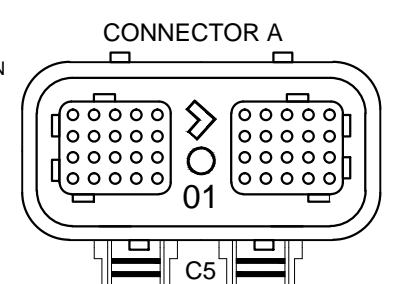
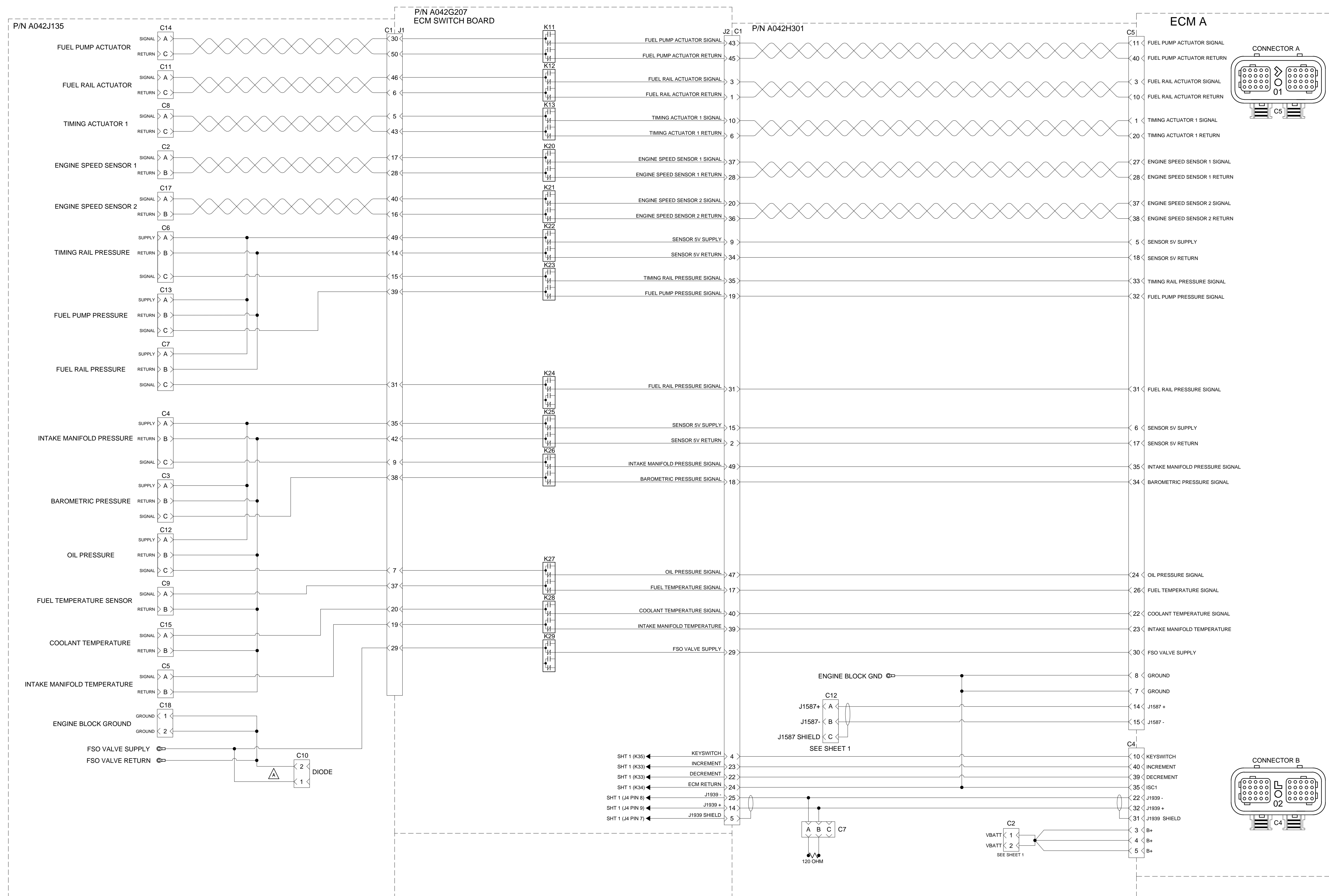

This document contains confidential and trade secret information, is the property of Cummins NPower LLC and is given to the receiver in confidence. The receiver, by accepting and installing it, shall be deemed to have agreed to maintain its confidentiality and shall not disclose it to any third party without the prior written consent of Cummins NPower. It will (1) not use the document or any part thereof for any purpose other than that intended, (2) not copy the document, (3) not disclose to others either the document or the confidential or trade secret information therein, and (4) not reproduce or transmit the document, or any portion, in any form or by any means, without the prior written consent of Cummins NPower. © 2016 Cummins NPower LLC.

UNLESS OTHERWISE SPECIFIED ALL DIMENSION TOLERANCES ARE:

ANGULAR DIMENSIONS ± 1°	IMPERIAL UNITS	METRIC UNITS
0.0005	0.0005	0.0127
0.0010	0.0010	0.0254
0.0015	0.0015	0.0381
0.0020	0.0020	0.0508
0.0030	0.0030	0.0762
0.0040	0.0040	0.1016
0.0050	0.0050	0.1270
0.0060	0.0060	0.1524
0.0070	0.0070	0.1778
0.0080	0.0080	0.2032
0.0090	0.0090	0.2286
0.0100	0.0100	0.2540
0.0120	0.0120	0.3048
0.0150	0.0150	0.3810
0.0200	0.0200	0.5080
0.0250	0.0250	0.6350
0.0300	0.0300	0.7620
0.0400	0.0400	1.0160
0.0500	0.0500	1.2700
0.0600	0.0600	1.5240
0.0800	0.0800	2.0320
0.1000	0.1000	2.5400
0.1200	0.1200	3.0480
0.1500	0.1500	3.8100
0.2000	0.2000	5.0800
0.2500	0.2500	6.3500
0.3000	0.3000	7.6200
0.4000	0.4000	10.1600
0.5000	0.5000	12.7000
0.6000	0.6000	15.2400
0.8000	0.8000	20.3200
1.0000	1.0000	25.4000

THIRD ANGLE PROJECTION

SCHEMATICS, OVERALL, CFP23E
FPDP GEN II

DWG UNITS: INCH/LB/S
SCALE: EST WEIGHT:

DRAWN BY: KAK
SHEET 2 OF 6
DRAWING NO: A042J126

DATE: 22 NOV 2016
INIT ECO: 2016-694

A	2017-498	SEE SHEET 1 FOR DETAILS	TJB	4AUG2017
REV	ECO	DESCRIPTION OF REVISION	BY	DATE

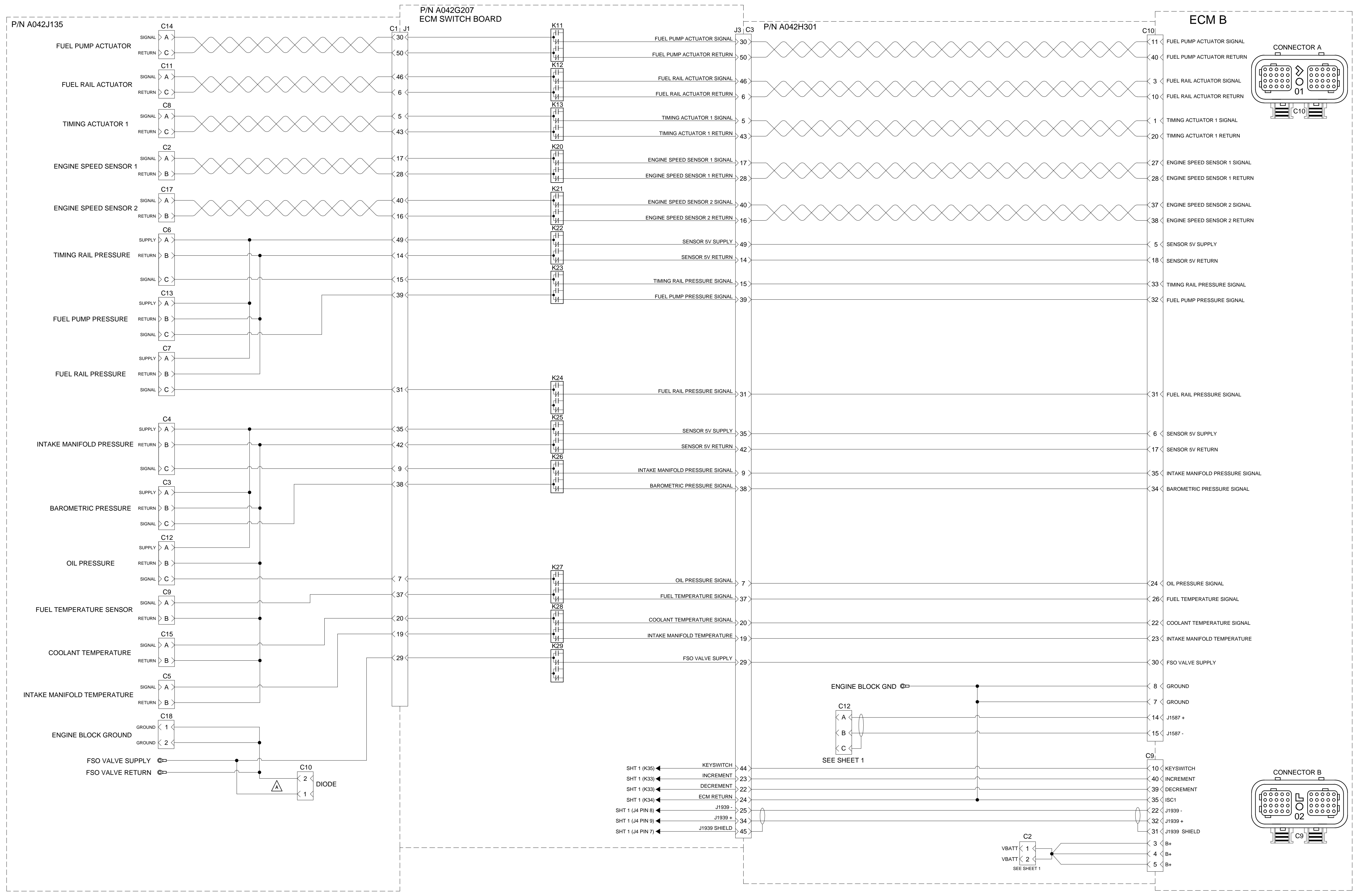

This document contains confidential and trade secret information, is the property of Cummins NPower LLC and is given to the receiver in confidence. The receiver is prohibited from disclosing this information to any third party without the prior written consent of Cummins NPower LLC. If you are not an authorized recipient, you should not disseminate, distribute, or copy this document. If you are an authorized recipient, you should not disseminate, distribute, or copy this document without the prior written consent of Cummins NPower LLC.

Cummins NPower

CUMMINS NPOWER LLC
CORPORATE OFFICE
1600 BUEKLE ROAD
WHITE SEAR LAKE, ILL.
WWW.CUMMINSPOWER.COM

CUSTOM DESIGN AND
UPFIT CENTER
875 LAWRENCE DRIVE
DEPORE, WISCONSIN

SCHEMATICS, OVERALL, CFP23E
FPDP GEN II

UNLESS OTHERWISE SPECIFIED ALL DIMENSION TOLERANCES ARE:
ANGULAR DIMENSIONS ± 1°
IMPERIAL UNITS: FRACTIONS
METRIC UNITS: DECIMALS

THIRD ANGLE PROJECTION

DWG UNITS: INCH/LB/S
SCALE: EST WEIGHT:

DRAWN BY: KAK
DATE: 22 NOV 2016

INIT ECO: 2016-694

SHEET 3 OF 6
DRAWING NO: A042J126

A	2017-498	SEE SHEET 1 FOR DETAILS	TJB	4AUG2017
REV	ECO	DESCRIPTION OF REVISION	BY	DATE

NO ASO OPTION WITH UP TO 3 SWITCHED INPUTS

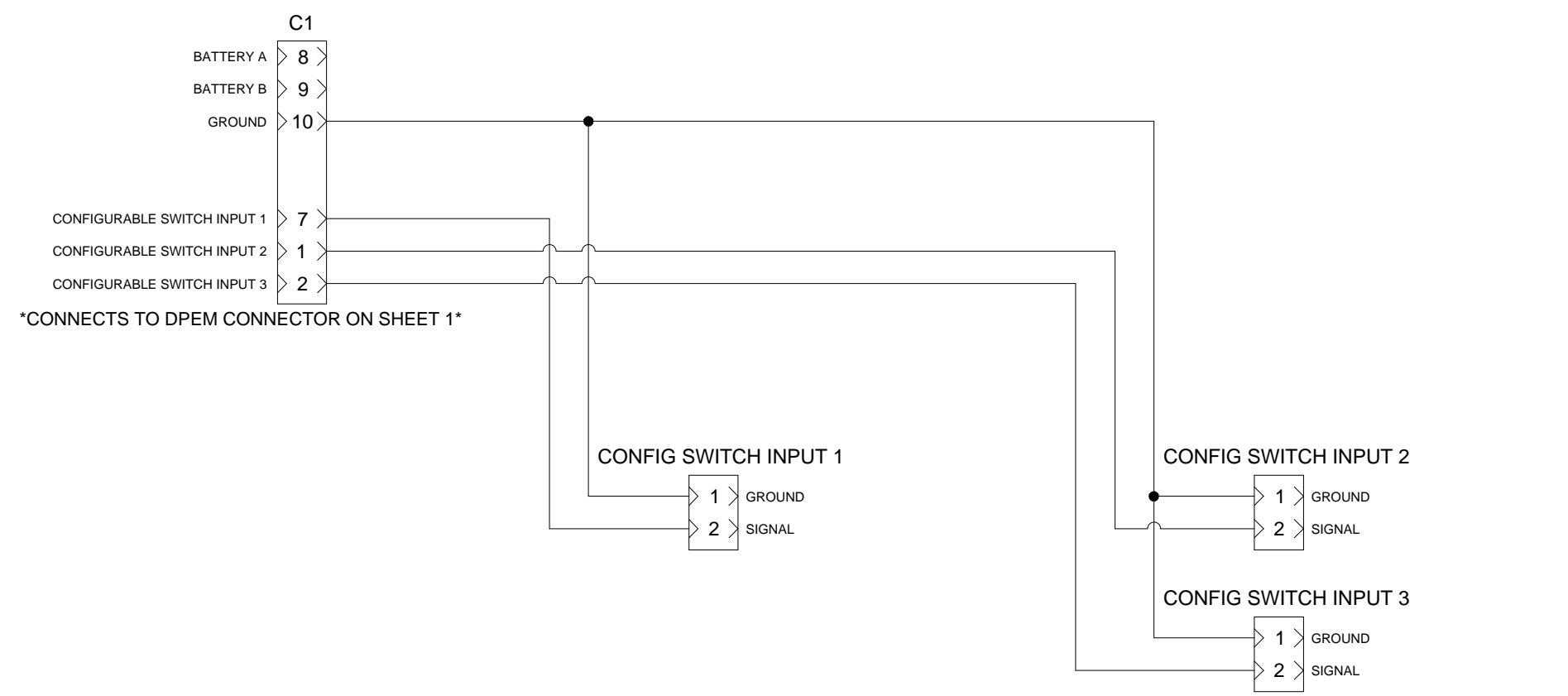

DPEM OPTION WITH NO ASO

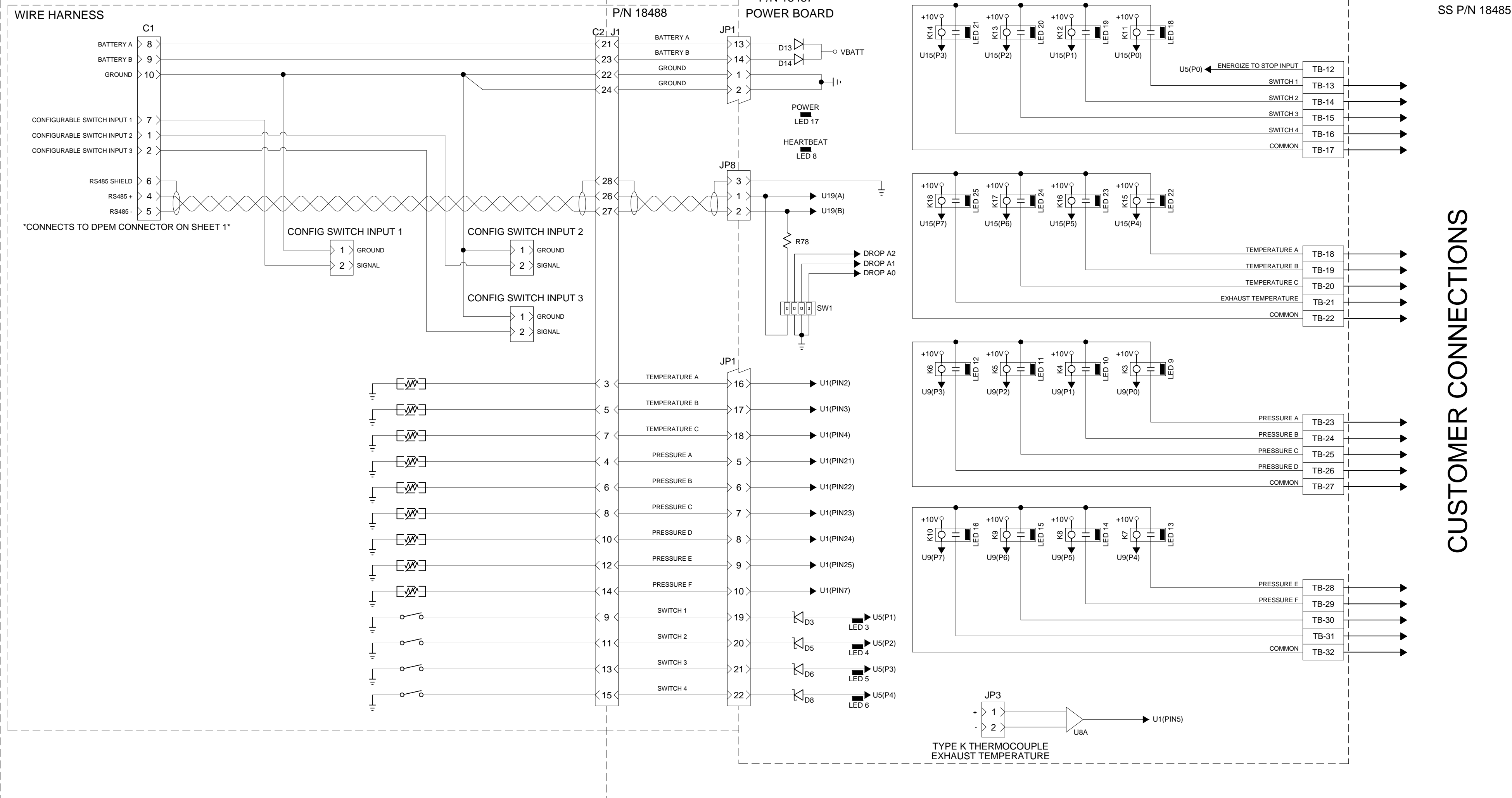

CUSTOMER CONNECTIONS

<small>This document contains confidential and trade secret information in the property of Cummins InPower LLC and is given to the receiver in confidence. The receiver is prohibited from disclosing this information to any third party without the written consent of Cummins InPower LLC. If you are not an intended recipient, you should not disseminate, distribute or copy this document. If you have received this document by mistake, please notify the sender immediately by e-mail at inpower@cummins.com. Cummins InPower LLC is not responsible for any actions taken in reliance on the information contained herein. © 2016 Cummins InPower LLC.</small>			CUMMINS INPOWER LLC CORPORATE OFFICE 1600 BUERKLE ROAD WHITE SEAR LAKE, IN WWW.CUMMINSINPOWER.COM	CUSTOM DESIGN AND UPLIFT CENTER 875 LAWRENCE DRIVE DEPOE, WISCONSIN
SCHEMATICS, OVERALL, CFP23E FPDP GEN II				
DWG UNITS: INCH/LB/S SCALE: EST WEIGHT:	DRAWN BY: KAK AUTO CAD	DATE: 22 NOV 2016 INIT ECO: 2016-694		
UNLESS OTHERWISE SPECIFIED ALL DIMENSION TOLERANCES ARE: ANGULAR DIMENSIONS ± 1° THIRD ANGLE PROJECTION				
A 2017-498 REV ECO	SEE SHEET 1 FOR DETAILS DESCRIPTION OF REVISION	TJB BY	4AUG2017 DATE	

A	2017-498	SEE SHEET 1 FOR DETAILS	TJB	4AUG2017
REV	ECO	DESCRIPTION OF REVISION	BY	DATE

IF AIR SHUT-OFF (ASO) IS SELECTED, THE UL/FM LISTING IS REMOVED AS THIS OPTION IS NOT ALLOWED PER THE STANDARDS.

ASO OPTION WITH UP TO 2 SWITCHED INPUTS

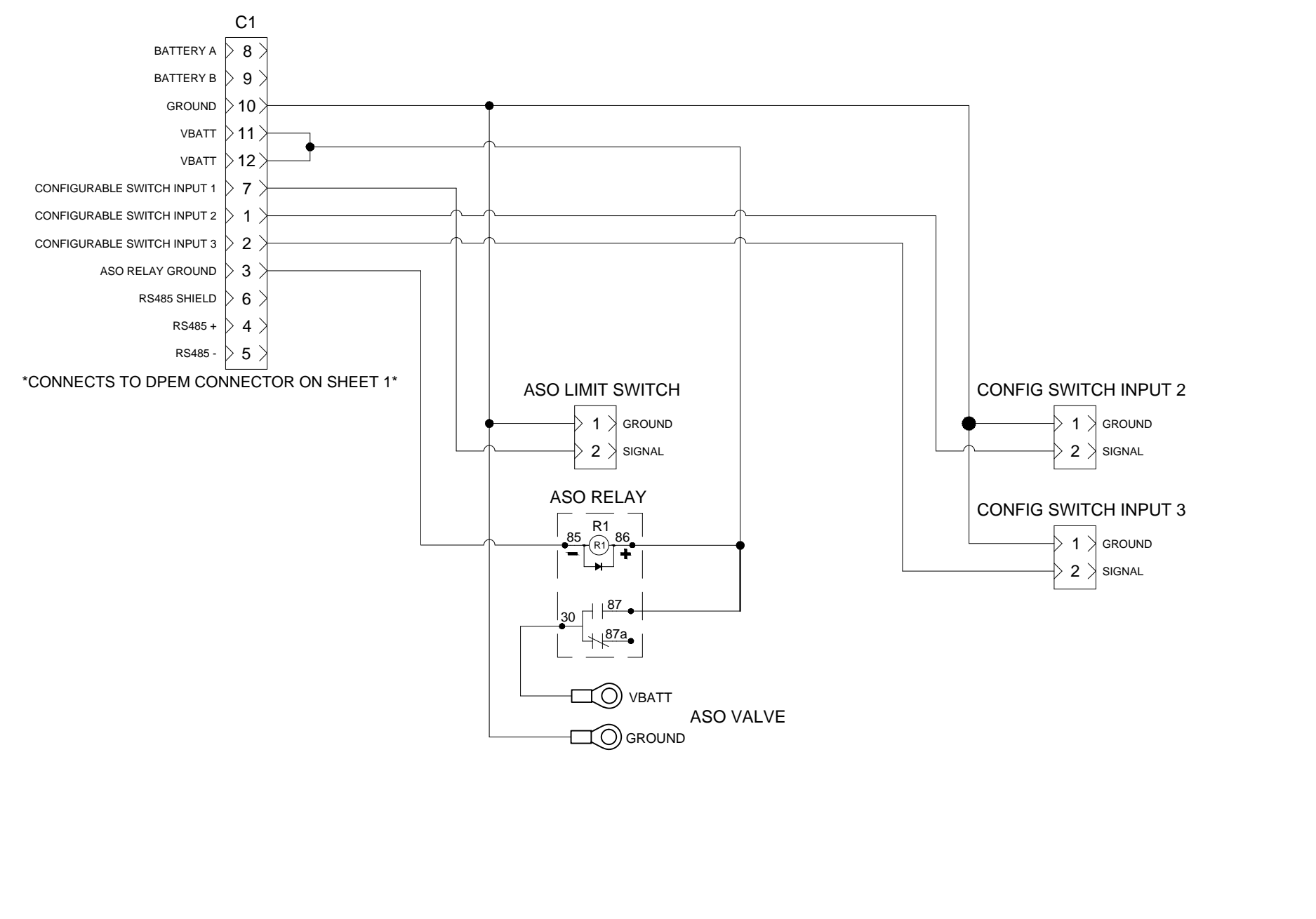

DPEM OPTION WITH ASO

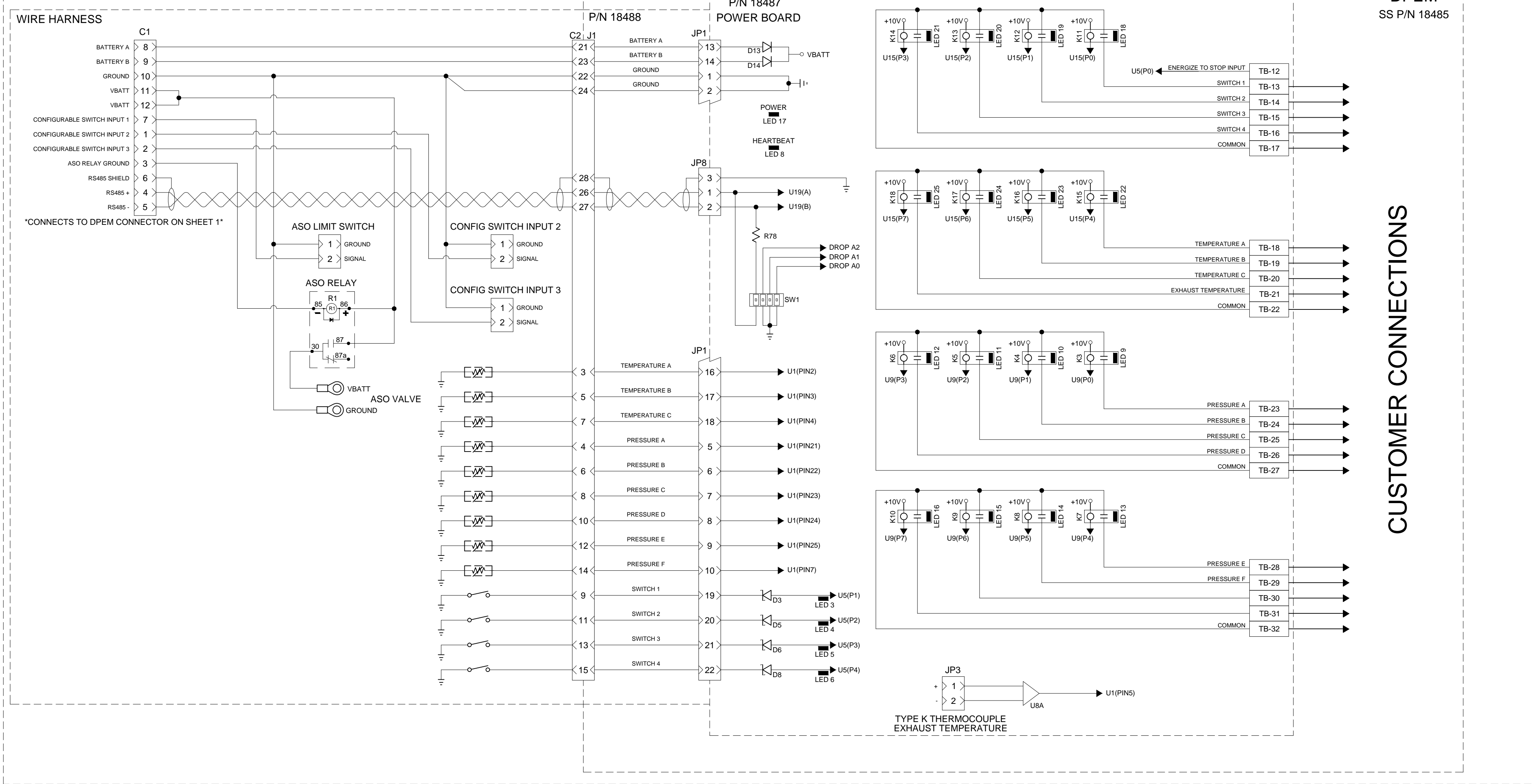

CUSTOMER CONNECTIONS

DPEM
SS P/N 18485

This document contains confidential and trade secret information in the property of Cummins NPower LLC and is given to the receiver in confidence. The receiver is prohibited from disclosing this information to any third party without the prior written consent of Cummins NPower LLC. If you are not an authorized recipient, you should not use this document. If you are an authorized recipient, you should not use this document for any purpose other than that for which it was intended. If you are not an authorized recipient, you should not use this document for any purpose other than that for which it was intended. If you are an authorized recipient, you should not use this document for any purpose other than that for which it was intended. © 2016 Cummins NPower LLC.

NPower
CUMMINS NPOWER LLC
CORPORATE OFFICE
1600 BUERKLE ROAD
WHITE SEAR LAKE, IN
WWW.CUMMINSNPOWER.COM

CUSTOM DESIGN AND
UPFIT CENTER
875 LAWRENCE DRIVE
DEPOE, WISCONSIN

SCHEMATICS, OVERALL, CFP23E
FPDP GEN II

ANGULAR DIMENSIONS ± 1°		IMPERIAL UNITS	METRIC UNITS	DWG UNITS:	DRAWN BY: KAK	DATE: 22 NOV 2016
THIRD ANGLE PROJECTION		INCH/LB/S	MM/KG	SCALE:	INIT ECO: 2016-694	
A	2017-498	SEE SHEET 1 FOR DETAILS	TJB	4AUG2017		
REV	ECO	DESCRIPTION OF REVISION	BY	DATE		

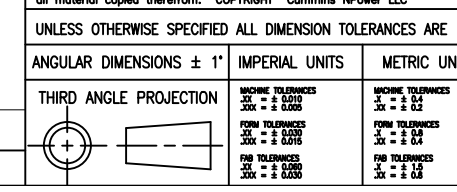

SHEET 5 OF 6
DRAWING NO: A042J126

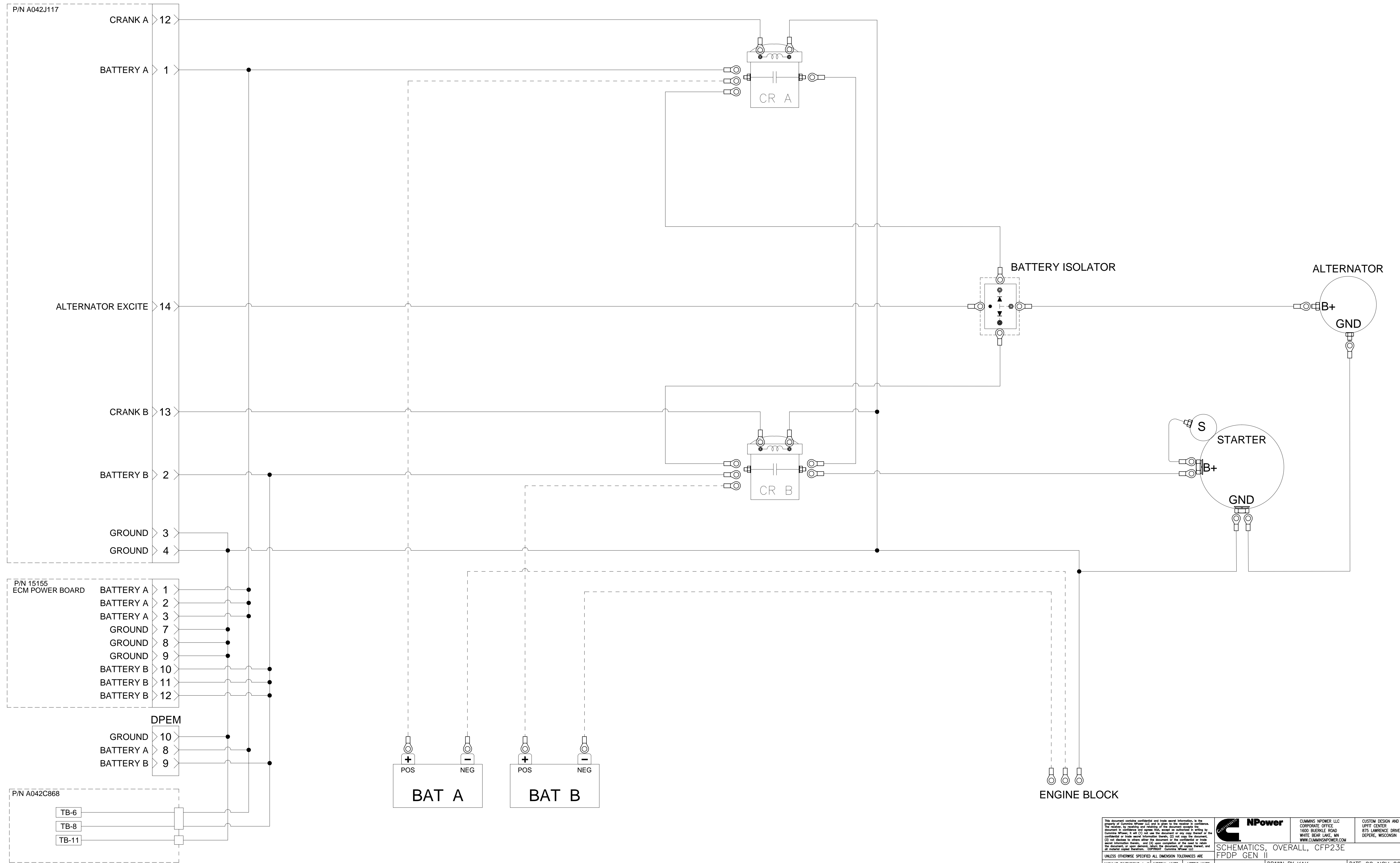

This document contains confidential and trade secret information, is the property of Cummins NPower LLC and is given to the receiver in confidence. The receiver, by accepting and installing of this document, accepts liability to Cummins NPower, it will (1) not use the document or any info thereof or the confidential or trade secret information therein, (2) not copy the document, (3) not disclose to others either the document or the confidential or trade secret information therein, and (4) use the information of the need for repair. The document, or any document, shall be destroyed or copied therefor, and all material copies therefrom, copyright © Cummins NPower LLC.

UNLESS OTHERWISE SPECIFIED ALL DIMENSION TOLERANCES ARE:
 ANGULAR DIMENSIONS ± 1°
 THIRD ANGLE PROJECTION
 IMPERIAL UNITS: INCH/LB/S
 METRIC UNITS: MM/KG

Cummins NPower
 CUMMINS NPOWER LLC
 CORPORATE OFFICE
 1600 BUERKLE ROAD
 WHITE SEAR LAKE, ILL.
 WWW.CUMMINSNPOWER.COM

CUSTOM DESIGN AND
 UPLIFT CENTER
 875 LAWRENCE DRIVE
 DEPERE, WISCONSIN

SCHMATICS, OVERALL, CFP23E
 FPDP GEN II

DWG UNITS: INCH/LB/S
 SCALE: EST WEIGHT:
 DRAWN BY: KAK
 AUTO CAD
 SHEET 6 OF 6
 DATE: 22 NOV 2016
 INIT ECO: 2016-694
 DRAWING NO: A042J126

A	2017-498	SEE SHEET 1 FOR DETAILS	TJB	4AUG2017
REV	ECO	DESCRIPTION OF REVISION	BY	DATE

BILL OF MATERIAL

ITEM	QTY	DESCRIPTION	PART NUMBER
1	1	BRACKET, PRESSURE TRANSMITTER	A042E427
2	1	TRANSMITTER, PRESSURE, DWYER: 626-13-GH-PI-E3-S4	A042E425

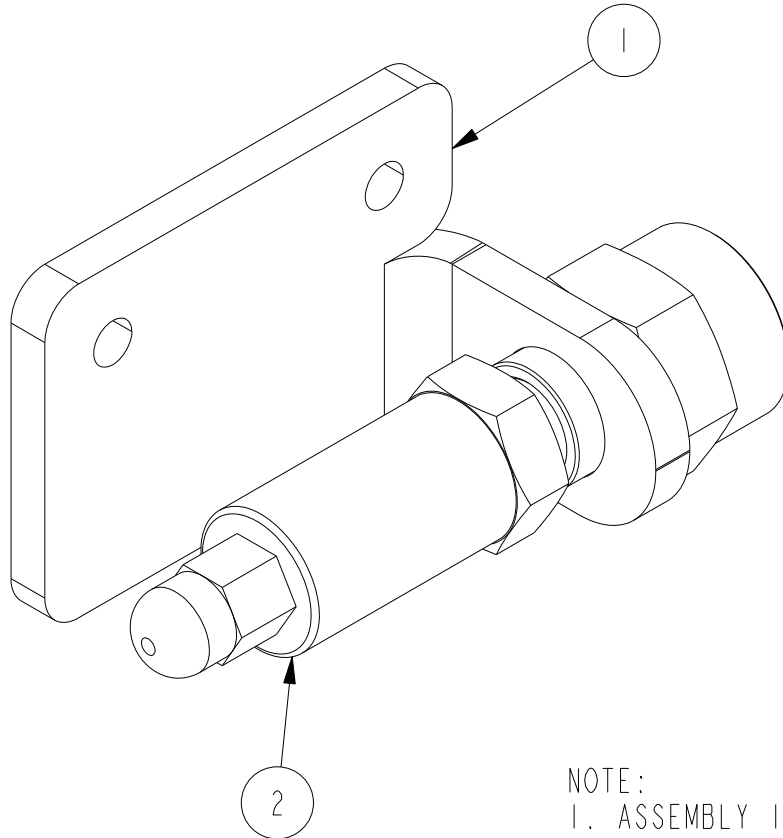

NOTE:
 1. ASSEMBLY INSTALLS BELOW THE DIGITAL CONTROL PANEL. USING THE SAME TWO HOLES AS THE DIGITAL CONTROL PANEL MOUNTING BRACKET.

This document contains confidential and trade secret information, is the property of Cummins FirePower LLC and is given to the receiver in confidence. The receiver, by receiving and retaining the document accepts the document in confidence and agrees that, except as authorized in writing by Cummins FirePower, it will (1) not use the document or any copy thereof or the confidential or trade secret information therein, (2) not copy the document, (3) not disclose to others either the document or the confidential or trade secret information therein, and (4) upon completion of the need to retain the document, or upon demand, return the document, all copies thereof, and all material copied therefrom. COPYRIGHT Cummins FirePower LLC



CUMMINS FIRE POWER LLC
 CORPORATE OFFICE
 1600 BUERKLE ROAD
 WHITE BEAR LAKE, MN
 WWW.CUMMINSFIREPOWER.COM

CUSTOM DESIGN
 AND UPFIT CENTER
 875 LAWRENCE DRIVE
 DEPERE, WISCONSIN

UNLESS OTHERWISE SPECIFIED
 ALL DIMENSION TOLERANCES ARE

ANGULAR DIMENSIONS ± 1°

MACHINED SURFACES	IMPERIAL UNITS	METRIC UNITS
125	MACHINE TOLERANCES	MACHINE TOLERANCES
	.X : ± 0.06	X : ± 1.5
	.XX : ± 0.010	XX : ± 0.5
WELD TOLERANCES	WELDED TOLERANCES	
.X : ± 0.25	X : ± 5	
.XX : ± 0.12	XX : ± 3	
.XXX : ± 0.06	XXX : ± 1.50	

ASSEMBLY, VSPLD
 PRESSURE TRANSMITTER

DWG UNITS: IN/LB/S	DRAWN BY: PBS PRO-ENGINEER	DATE: 09APR2015 INIT ECO: 2015-227
EST WEIGHT: 1.404	SHEET 1 OF 1	DRAWING NO: A042E428
SCALE: 1.000		

REV	ECO	DESCRIPTION OF REVISION	REV BY	DATE