

ARTICULATED BOOM LIFT MODEL TA34

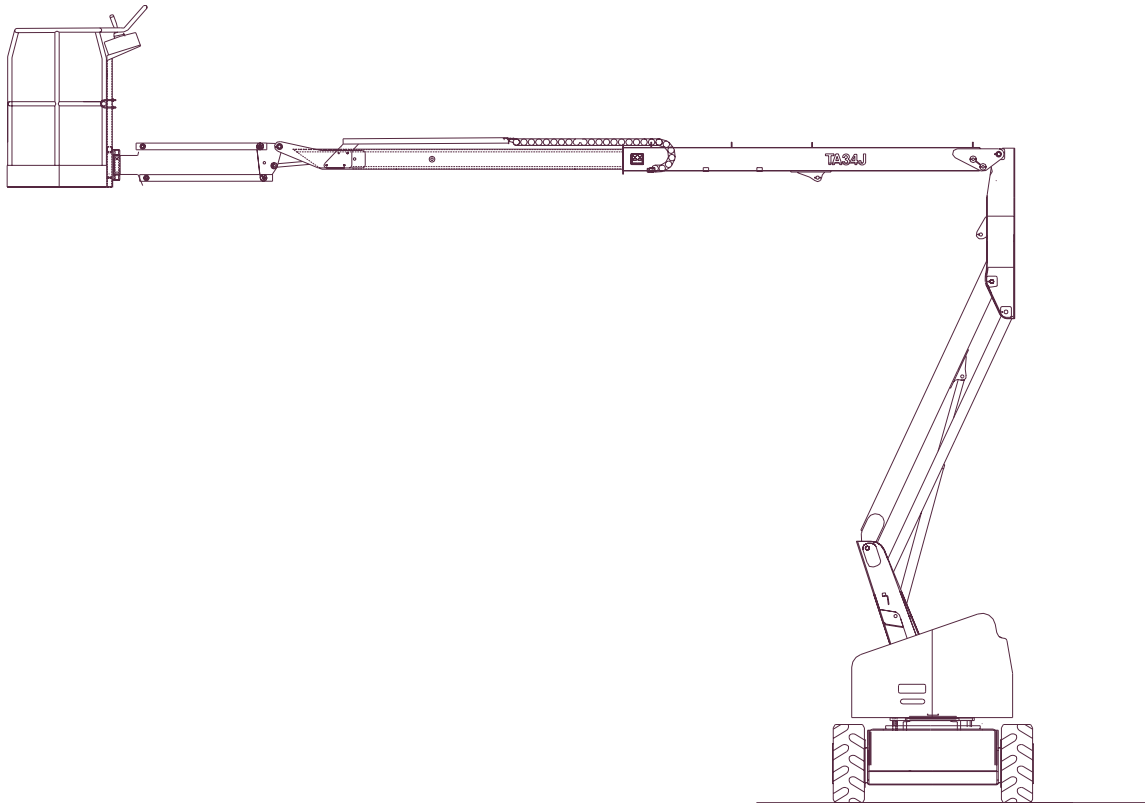

OPERATOR'S MANUAL

TEREX AERIALS
10600 W. Brown Deer Road
Milwaukee, WI 53224
U.S.A.
Telephone:(414) 362-9300
Facsimile:(414) 355-0832

TEREX AERIALS
Courtstown Industrial Park
Little Island,
Co. Cork, Ireland.
Telephone: (353) 21-353011
Facsimile: (353) 21-353368

TEREX AERIALS
106 12th Street S. E.
Waverly, IA 50677
U.S.A.
Telephone:(319) 352-3920
Facsimile:(319) 352-5727

INTRODUCTION

Owners, Users and Operators:

Terex Aerials appreciates your choice of our aerial lift for your application. Our number one priority is user safety, which is best achieved by our joint efforts.

We feel that you can make a major contribution to safety if you as the equipment user and operator:

1. **Comply** with OSHA, Federal, State and Local Regulations.
2. **Read, understand and follow** the instructions in this and other manuals supplied with this machine.
3. Use **good, safe work practices** in a common sense way.
4. Have only **trained operators** - directed by **informed and knowledgeable supervision** - running the machine.

If there is anything in this manual that is not clear or which you believe should be added, please send your comments to the Technical Publications Department, Terex Aerials, Courtstown Industrial Park, Little Island, Co. Cork Ireland. Telephone: +353-21-353011, Fax: +353-21-353368 or email: nscott@terex.ie

To help you recognize important safety information, we have identified warnings and instructions that directly impact on safety with following signals:



THESE SYMBOLS MEAN YOUR SAFETY IS INVOLVED! SEE NEXT PAGE FOR SPECIFIC INFORMATION. READ, UNDERSTAND AND FOLLOW ALL DANGER, WARNING AND CAUTION DECALS ON YOUR MACHINE.

INTRODUCTION



“DANGER” INDICATES AN IMMINENTLY HAZARDOUS SITUATION WHICH, IF NOT AVOIDED, WILL RESULT IN DEATH OR SERIOUS INJURY. THIS SIGNAL WORD IS LIMITED TO THE MOST EXTREME SITUATIONS.



“WARNING” INDICATES A POTENTIALLY HAZARDOUS SITUATION WHICH, IF NOT AVOIDED, COULD RESULT IN DEATH OR SERIOUS INJURY.



“Caution” indicates a potentially hazardous situation which, if not avoided, may result in minor or moderate injury. It is also used to alert against unsafe practices, and for property-damage-only situations.

One Final Note:

The best method to protect yourself and others from injury or death is to use common sense. If you are unsure of any operation, don't start until you are satisfied that it is safe to proceed and have discussed the situation with your supervisor.

Thank you!

CONTENTS

Section 1 - TA34 Specifications

Description	Page No.
1.1 Design Specifications	1-1
1.1.1 Closed Dimensions and Weights	1-1
1.1.2 Operating Dimenstions	1-1
1.1.3 Design Specifications	1-1
1.1.4 Working Envelope.	1-2
1.1.5 General Arrangement	1-3
1.2 Component Specifications.	1-4
1.2.1 Mechanical Components	1-4
1.2.2 Hydraulic Components	1-4
1.2.3 Oil	1-4
1.2.4 Equivalent Oils	1-4
1.2.5 Electrical Components.	1-5

Section 2 - Safety Precautions

Description	Page No.
2.1 Safety Rules and Precautions	2-1
2.2 Safety Features	2-7
2.2.1 Emergency Stop Push Buttons	2-7
2.2.2 Footswitch Control	2-7
2.2.3 Tilt Alarm	2-7
2.2.4 Movement Alarm	2-7
2.2.5 Torque Chart.	2-8

CONTENTS

Section 3 - Operating Procedures

Description	Page No.
3.1 Pre-use Checks	3-1
3.2 Ground Control Checks	3-2
3.3 Cage Control Checks	3-2
3.4 Unloading Procedures	3-3
3.5 Driving.	3-5
3.5.1 Drive Controls	3-5
3.5.1.1 Forward and Reverse	3-5
3.5.1.2 Drive Speed Control	3-9
3.5.1.3 Steering Control	3-9
3.6 Braking System	3-10
3.6.1 Brakes in Static Mode	3-10
3.6.2 Brakes in Drive Mode	3-10
3.6.3 Emergency Braking	3-10
3.7 Access Operations (Cage Control)	3-11
3.8 Access Operations (Ground Control)	3-12
3.9 After Use and Storage Instructions	3-14
3.10 Battery Charging.	3-15
3.10.1 Battery Charger on EU Machines	3-15
3.10.2 Battery Charger on US Machines	3-16
3.11 Battery Indicator.	3-17
3.12 Special Precautions (Cold Weather).	3-18
3.13 Special Precautions	3-19
3.13.1 Towing.	3-19
3.13.2 Wind Conditions.	3-19
3.13.3 Crane Operations	3-19
3.13.4 Driving on Slopes	3-19
3.13.5 Testing the Tilt Alarm	3-20

CONTENTS

Section 4 - Emergency Procedures & Systems

	Description	Page No.
4.1	Emergency Procedures	4-1
4.1.1	<u>Situation</u> : Platform elevated, operator not incapacitated, but unit will not operate properly using the platform controls.	4-1
4.1.2	<u>Situation</u> : Unit elevated, with operator incapacitated at platform controls.	4-2
4.1.3	<u>Situation</u> : Platform in contact with live power lines, and operator incapacitated.	4-2
4.2	Emergency Systems & Procedures	4-3
4.2.1	Emergency Pump	4-3
4.2.2	Emergency Rotation	4-3
4.2.3	Emergency Towing	4-4
4.3	Emergency Lowering	4-5
4.3.1	Emergency Lowering From Ground.	4-5

CONTENTS

Section 5 - Maintenance Schedules

Description	Page No.
5.1 General Information	5-1
5.1.1 Introduction	5-1
5.1.2 Hydraulic Oils	5-1
5.2 Servicing Check List (Basic Machine Only)	5-3
5.2.1 Servicing (Daily)	5-3
5.2.2 Servicing (Weekly)	5-4
5.2.3 Servicing (Monthly)	5-5
5.2.4 Servicing (Six Monthly)	5-6
5.2.5 Servicing (Yearly)	5-7
5.2.6 Servicing (Four Yearly)	5-7
5.3 Servicing.	5-8
5.3.1 Daily Routine Servicing.	5-8
5.3.1.1 Hydraulic Oil Level	5-8
5.3.1.2 Tyre Condition.	5-8
5.3.2 Weekly Routine Service.	5-8
5.3.2.1. Hydraulic System	5-8
5.3.2.2. Steering	5-8
5.3.2.3. Pivot Pins	5-9
5.3.3. Monthly Routine Servicing	5-10
5.3.3.1 Chassis Bolts.	5-10
5.3.3.2 Slewing Ring Gear Teeth	5-10
5.3.3.3 Lubrication.	5-10
5.3.3.4 Pivot Pin Security	5-10
5.3.4 Six Monthly Routine Servicing	5-11
5.3.4.1 Cage Levelling.	5-11
5.3.4.2 Boom Pivots	5-11
5.3.4.3 Boom Cylinders	5-11
5.3.4.4 Drive Hubs.	5-11
5.3.4.5 Pressure Line Filter	5-11
5.3.4.6 Machine Systems Test.	5-11

CONTENTS

Section 5 - Maintenance Schedules

	Description	Page No.
5.3.5	Yearly Routine Servicing	5-12
5.3.5.1	Hydraulic Oil	5-12
5.3.5.2	Hydraulic Oil Reservoir	5-12
5.3.5.3	Hydraulic Reservoir Refill Procedure	5-12
5.3.5.4	Structural Examination	5-12
5.3.5.5	Cage Mounting	5-12
5.3.5.6	Levelling Cylinders	5-12
5.3.6	Four Yearly Routine Servicing	5-13
5.3.6.1	Flexible Hoses	5-13
5.3.6.2	Pivot Pins and Bearings	5-13
5.3.6.3	Pin Replacement	5-13
5.3.6.3.1	Boom Pin Replacement	5-13
5.3.6.3.2	Tie Rail Pin Replacement	5-14
5.3.6.3.3	Lift Cylinder Pin Replacement	5-14
5.3.6.3.4	Self Levelling Cylinder Pin Replacement	5-14
5.3.6.3.5	Zoom Boom Cylinder Pin Replacement	5-14
5.3.6.4	Zoom Cylinder	5-15
5.3.6.5	Zoom Pads	5-15
5.3.6.5.1	Front Zoom Pad Replacement	5-15
5.3.6.5.2	Rear Zoom Boom Replacement	5-15
5.3.6.6	Lift Cylinder Seals	5-15
5.3.6.6.1	Seal Replacement - Cylinder In-place	5-16
5.3.6.6.2	Seal Replacement - Cylinder Removed	5-16
5.4	Lubrication	5-17
5.4.1	General Lubrication	5-17
5.4.2	Slew Bearing/Gear Lubricants	5-18
5.4.2.1	Slew Bearing Lubrication	5-18
5.4.2.2	Slew Gear Lubrication	5-18

SPECIFICATIONS

1.1 DESIGN SPECIFICATION

1.1.1 CLOSED DIMENSIONS AND WEIGHTS

Length	5.0m
Width	1.50 m
Height	1.97 m
Unladen Weight	4820 kg

1.1.2 OPERATING DIMENSIONS

Maximum Cage Floor Height	10.36 m
Maximum Working Height	12.36 m
Maximum Working Outreach	7.1 m
Standard Platform Dimensions	35 m x 0.72 m
Outside Turning Circle	3.10 m
Gradability	14%
Maximum Speed, Booms Stowed	4 km/hr (2.5 mph)
Maximum Speed, Booms Elevated	0.75 km/hr (0.5mph)
Ground Clearance	0.14 m
Maximum Wheel Loading.....	3000 kg

1.1.3 DESIGN SPECIFICATION

Safe Working Load (2 persons)	225 kg (500 lbs)
Maximum Horizontal Platform Pull	40 kg (88 lb)
Maximum Wind Speed	12.5 m/sec (28 mph - 45 km/hr)
Maximum Slope for Safe Operation	3°
Full Range Time Up Min.....	75±10 secs
Swing Left/Right	80±10 secs
Maximum Noise Emmission.....	70 dB(A) @ 3m
Temperature Operating Range.....	-5°C to +40°C

SPECIFICATIONS

1.1.4 WORKING ENVELOPE

The TA34 has a working height ability of 12.36 m. The following diagram shows the working envelope for the TA34. All dimensions are in metres.

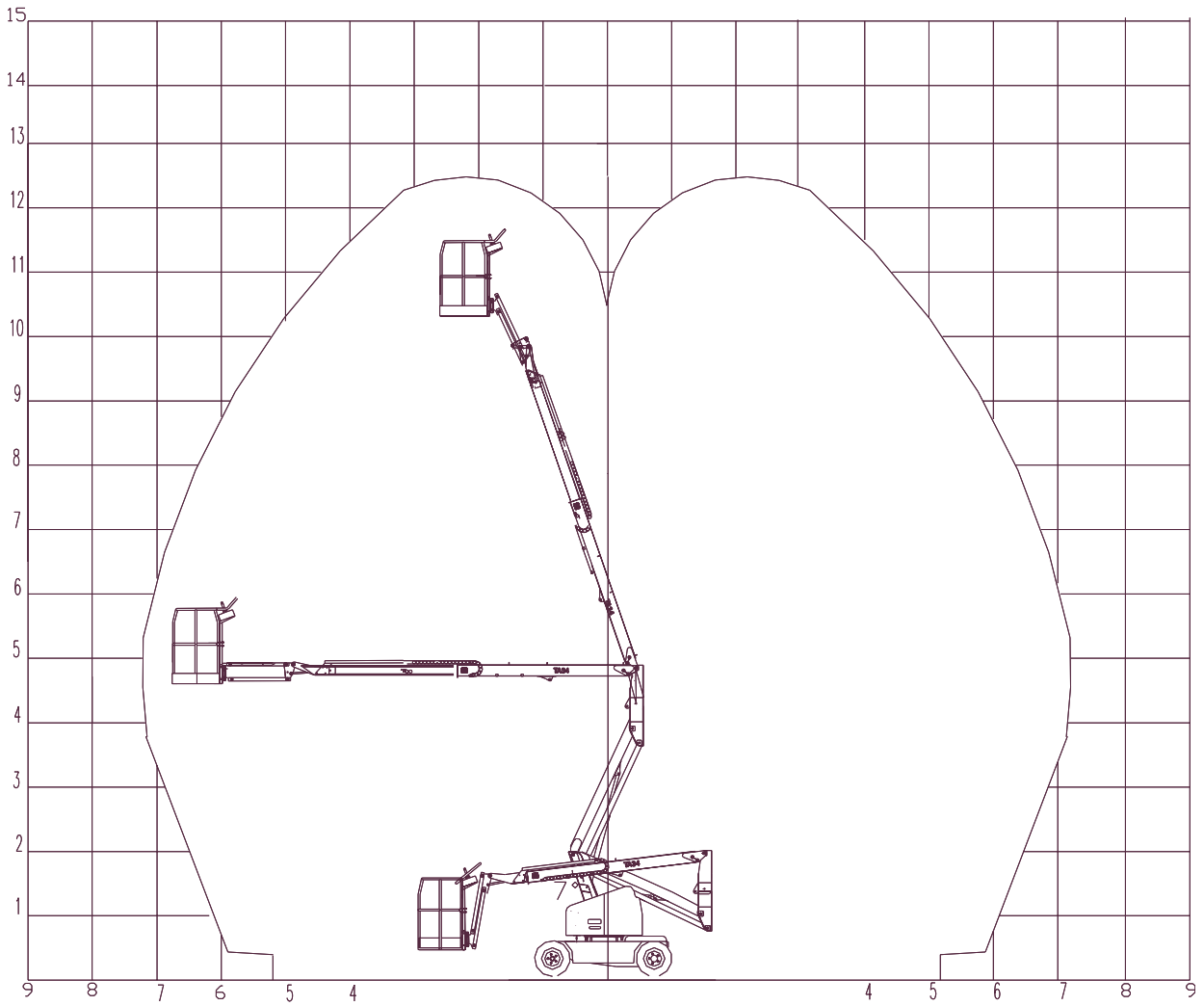

Figure 1.1 - TA34 Working Envelope

SPECIFICATIONS

1.1.5 GENERAL ARRANGEMENT

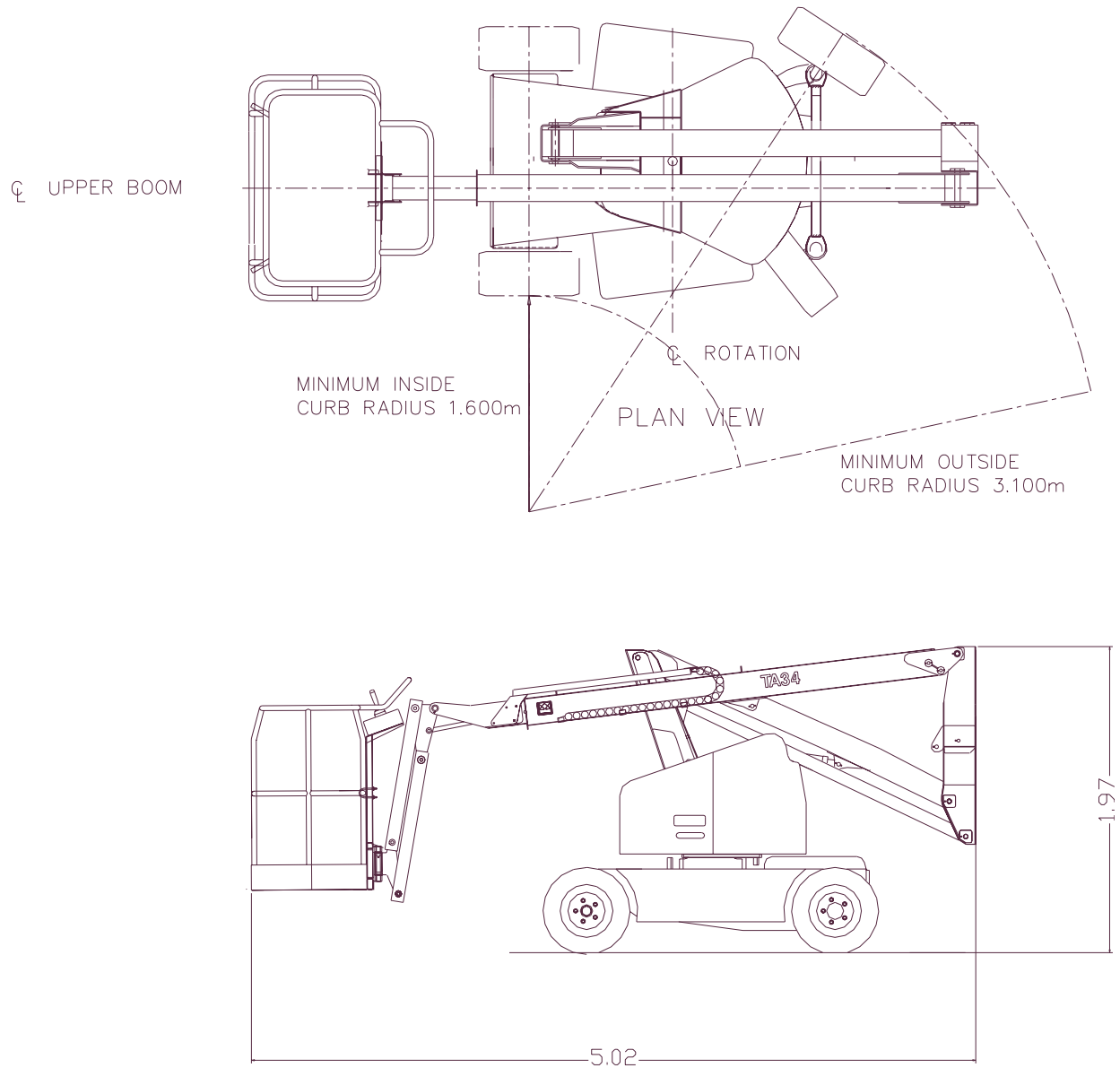

Figure 1.2 - TA34 General Arrangement.

SPECIFICATIONS

1.2 COMPONENT SPECIFICATIONS

1.2.1. MECHANICAL COMPONENTS

Tyre Type Solideal Black
 Tyre Size 23 x 10
 Gearbox 42.2 : 1 ratio
 Wheel Diameter 70 cms
 Brakes Oil Immersed discs integral inside the drive gearbox with and failsafe operation serve as both parking and service brakes. The brakes are released when the footswitch is depressed and the joystick is moved to either forward or reverse motion.

1.2.2 HYDRAULIC COMPONENTS

Lift Cylinders Double -acting with overcentre valves
 Hoses Thermoplastic
 Filtration Suction

1.2.3 OIL

Type Texaco Rando HDZ-32
 Oil Reservoir Capacity 9 Litres

1.2.4 EQUIVALENT OILS

SHELL	TELLUS T32
CASTROL	HYSPIN AWH 32
ESSO	UNIVERSE N32
CASTROL	HYSPIN AWS 22

SPECIFICATIONS

1.2.5 ELECTRICAL COMPONENTS

Pump Motor	48 V, 3 kW, 1200 rpm, Flow rate 10 l/min
Pump Pressure	155 bar (2250 psi)
Drive motor	48V, 1.5kW, series-wound reversible. Solid state controlled.
Hand Controller Type	Joystick
Batteries - Option 1	Eight 6V monoblock, 175 Amp-hour
Batteries - Option 2	Twenty-four 2V heavy duty, 217 Amp-hour
Battery Charger - Standard	Dart/AITB 48V, 25A charging Single 240V, 50Hz input

SAFETY PRECAUTIONS



2.1 SAFETY RULES AND PRECAUTIONS

ELECTROCUTION HAZARD! THIS MACHINE IS NOT INSULATED!! Maintain safe clearance from electrical lines and apparatus. You must allow for machine sway (side to side movement) when elevated, and electrical line movement. This machine does not provide protection from contact with or proximity to an electrically charged conductor.

You must **AVOID CONTACT** between any part of the machine, or its load, and any electrical line or apparatus carrying up to 300 volts.

You must maintain a **CLEARANCE OF AT LEAST 10 FEET (3.05 M)** between any part of the machine, or its load, and any electrical line or apparatus carrying over 300 volts up to 50,000 volts. One foot (30.5 cm) additional clearance is required for every additional 30,000 volts.

DEATH OR SERIOUS INJURY will result from contact with, or inadequate clearance from, any charged conductor.

Read and understand all safety and control information found on the machine and in this manual before operating the unit.

Only trained, competent personnel should operate the aerial work platform.

Be aware of all Government and Local rules which may apply to this machine and its safe operation.

SAFETY PRECAUTIONS



Approved safety belts must be worn at all times when operating the unit from the platform. In addition approved headgear and other protective equipment must be worn as required. (The appropriate equivalent government body should be consulted).

NEVER fasten safety belt to an adjacent structure while on the work platform.

Make sure that entry gate to platform is secured before operating unit from the platform.

DO NOT block the foot pedal or any function control in the operating position.

DO NOT exceed the platform capacity of the unit in any configuration. Review the section titled "MACHINE SPECIFICATIONS", earlier in this manual, regarding this model's capacities and dimensions.

SECURE all tools and other loose items to prevent injury to persons working on or below the work platform.

DO NOT use scaffolding, ladders or similar items to extend your reach while on the work platform.

DO NOT attempt to climb down the boom assembly, if the unit fails while the operator's platform is raised or extended.

Since the machine may be operated from its ground controls, precautions should be taken to prevent unauthorised personnel from operating the work platform with the ground controls while the platform is in use.

The "UNPOWERED EMERGENCY MOVEMENT" procedure (described later in this manual) required releasing the brakes and disconnecting the rear wheels, which results in there being no means to stop the unit's travel. Terex recommends using this procedure only in cases of emergency, and only for a short distance. Be on guard against unit runaway on sloping surfaces. Movement speed shall not exceed 3 MPH (5 KPH).

SAFETY PRECAUTIONS



DO NOT attempt to open any hydraulic line or component without first relieving system pressures and shutting off fluid flow from the tank.

DO NOT allow anyone to tamper with, service or operate the machine from the ground control station while personnel are on the platform, except in an emergency.

DO NOT alter, modify or disable any safety devices or interlocks.

DO NOT use the aerial work platform outdoors in electrical storms or in high wind situations. Maximum rated wind speed is 12.5 m/s.

DO NOT increase wind area of cage by addition of sheltering material

DO NOT raise the aerial work platform unless the unit is on a firm surface, and slope is within rated slope of the machine.

When working underneath elevated booms, ensure they are propped using chock provided for this purpose.

Use caution to prevent ropes, cords, hoses, etc. from becoming entangled in the unit's boom sections when being raised, lowered or repositioned.

Ensure that the area surrounding the mobile platform is clear of personnel and equipment before: driving the unit; raising, lowering or extending the boom, or swinging the superstructure; or tilting the platform.

Maintain a safe distance from overhead and ground obstacles, debris, drop-offs, holes, depressions, electrical wires and other hazards to travel.

SAFETY PRECAUTIONS



Limit travel speed according to conditions of the ground surface, congestion, slope, location of personnel or any other factors that could cause hazard of collision of injury to personnel.

DO NOT sit, stand or climb on platform rails.

DO NOT operate this machine while under the influence of any drugs or alcohol.

DO NOT operate this machine if you are bothered by heights, seizures, or dizzy spells.

DO NOT indulge in stunt driving or horseplay while operating this machine.

SAFETY PRECAUTIONS



Complete the “Operational Checklists” found in this manual (see Table of Contents) at designated intervals.

Always attach the unit to a winch when loading or unloading from a truck or trailer. Terex does not recommend unassisted loading or unloading of any aerial work platform.

With the platform swung away from the stowed position, use caution when selecting travel or steering direction. Travel and steer direction will be opposite to switch or lever movement. Refer to the directional arrow decals on the undercarriage of the unit for travel orientation.

Actuation of the red “EMERGENCY STOP” button will apply brakes immediately, causing unexpected platform movement as the machine comes to a sudden stop. Brace yourself.

Whenever releasing the brakes, ensure that the unit cannot roll.

Immediately report any erratic noises, vibrations or malfunctions of the unit to a supervisor. Machine shall be removed from service until diagnosis and any necessary repairs have been completed.

Operating this equipment without all safety and control decals in place can be hazardous.

SAFETY PRECAUTIONS



For transporting the machine, the platform or boom must not be tied to the trailer bed in any way.

DO NOT exceed the maximum platform horizontal pull of 400 N.

DO NOT use the boom or platform as a crane to lift oversized or hanging loads.

DO NOT raise, extend, retract, tilt, or lower the platform into stationary objects, as this will cause damage to mechanical and hydraulic components.

DO NOT use the platform or boom functions to push or tow the unit or another vehicle.

DO NOT use the boom as a crane or hoist.

Avoid sudden braking or steering, go slowly and leave more manoeuvring room during cold weather operation until the machine is warm.

Noise emission levels on this machine are less than 70 dB(A). @ 3m.

WASHING INSTRUCTIONS : Always direct the high pressure jets of water away from the upper control box, and electric components in general. When cleaning is required, clean with a damp cloth. We recommend that during machine transport, and while being washed, the upper control box is protected or that the upper control box cover (Part No. 33014-0071) is used..

SAFETY PRECAUTIONS

2.2 SAFETY FEATURES

2.2.1 EMERGENCY STOP PUSH BUTTONS

Two EMERGENCY STOP pushbuttons, one at the ground station and one in the cage, act as power on/off switches. Both switches must be ON to operate the machine. When either of the buttons is depressed, all functions stop immediately and the parking brake is automatically applied.

2.2.2 FOOTSWITCH CONTROL

The footswitch must be fully depressed before any machine operation can be carried out from the cage.

When the footswitch control is released, the electric supply to the hydraulic pump and the drive function is terminated and all machine functions stop.

2.2.3 TILT ALARM

The tilt alarm gives an audible warning when the machine is out of level by more than the degree for which the sensor has been rated.

2.2.4 MOVEMENT ALARM

The movement alarm is activated as soon as the machine is in drive mode.

SAFETY PRECAUTIONS

2.2.5 TORQUE CHART

ITEM	BOLT SPECIFICATION		REQUIRED TORQUE	
	Thread Size	Grade	Nm.	lbft.
Wheel Nut	M18	10.9	200	147.5
Slewing Bolt TA34	M12	10.9	120	88.23
Gearbox Bolt	M12	12.9	160	118
General Bolts	M8	8.8	27.5	20
General Bolts	M10	8.8	55	40.5
General Bolts	M12	8.8	95	70
General Bolts	M16	8.8	236	174
General Bolts	M8	10.9	39	29
General Bolts	M10	10.9	70	51.5
General Bolts	M12	10.9	134	99
General Bolts	M16	10.9	333	245.5
General Bolts	M10	12.9	85	62.5
General Bolts	M12	12.9	160	118

Figure 2.1 : Torque Setting Chart

OPERATING PROCEDURES



3.1. PRE-USE CHECKS

Before the TA34 is used at the start of a day, or after an extended period without use, the following checks should be carried out to ensure that the machine is in good condition and safe to use:

- (a) Check all battery electrolyte levels and connections.
- (b) Check that all labels are readable and secure.
- (c) Check the hydraulic oil level.
- (d) Check that the battery charger is disconnected from the mains supply.
- (e) Check tyres for damage.
- (f) Check wheel bolts for security.
- (g) Check the tilt alarm.
- (h) Check P.C.B card for any faults.

OPERATING PROCEDURES

3.2. GROUND CONTROL CHECKS



DO NOT OPERATE THE MACHINE IF THE GROUND CONTROL CHECKS REVEAL A FAULT.

Ensure that the following checks are carried out with the cage empty:

- (a) Test all operations (lift, rotate, etc.).
- (b) Check for the following:
 - (i) Uneven or jerky operation
 - (ii) Hydraulic oil leaks
 - (iii) Pivot pin security. Ensure that all securing bolts are in place on each locking point.

3.3. CAGE CONTROL CHECKS



DO NOT OPERATE THE MACHINE IF THE CAGE CONTROL CHECKS REVEAL A FAULT.

Ensure that the following checks are carried out on a level surface:

- (a) Carry out the checks described in section 3.2. Carefully observe boom speed.
- (b) Check the drive, and emergency braking.
- (c) Check the slow drive speed with the lower boom slightly elevated.
- (d) Check the fast drive speed with all the booms fully down.

OPERATING PROCEDURES

3.4. UNLOADING PROCEDURES



TO AVOID SERIOUS PERSONAL INJURY OR DEATH, ENSURE THAT THE MACHINE IS IN “CREEP “ DRIVE SPEED WHILE UNLOADING FROM A TRUCK OR TRAILER

Inspect the outside of the unit for damage (including the underside). Inspect all hoses, boom sections and cables for chafing or road damage. Confirm that all swing bearing bolts are tight (refer to specifications).

Unlock and open hydraulic compartment. Inspect all electrical and hydraulic connections for damage and security.

Connect battery cables to batteries if required. Check electrolyte levels.

Check fluid level on the hydraulic tank, and add fluid as required (see lubrication chart).

Replace plinth cover.

Attach the unit to a winch for the unloading procedure.

OPERATING PROCEDURES



ALWAYS ATTACH THE UNIT TO A WINCH WHEN LOADING OR UNLOADING FROM A TRUCK OR TRAILER. CONNECT WINCH TO THE TIE DOWN LUGS ON THE UNDERCARRIAGE. UNASSISTED LOADING OR UNLOADING OF ANY MOBILE PLATFORM IS NOT RECOMMENDED.

READ AND UNDERSTAND ALL SAFETY, CONTROL AND OPERATING INFORMATION FOUND ON THE MACHINE AND IN THIS MANUAL BEFORE OPERATING THE UNIT.

Remove all machines tie downs. Remove wheel chocks, if used. Turn the Power On keyswitch to Cage (platform) position.

Enter the platform. Test all platform functions.

Raise the boom so that the platform will clear any obstacles as the machine is driven down the loading ramp.

Carefully drive the unit off the truck or trailer with the assistance of a winch

Note: The brakes are automatically released for driving, and will automatically apply when the unit stops.

Before placing the unit into service, all operators must read and understand the contents of the Operator's Manual.

Upon initial unloading of the machine the PDI (Pre-Delivery Inspection Form) must be completed and returned in order to activate the Terex Limited Warranty.

OPERATING PROCEDURES

3.5. DRIVING



It should be noted that the machine is not equipped for highway use and should only be driven on the public highway in compliance with any statutory regulation.

The drive controls are located in the cage and the machine can be driven with the cage positioned at either end of the machine. If driving is attempted from the 'steering' end of the machine, all directions given to the controls will be reversed so the operator may find driving easier with the cage positioned at the 'drive' end. Arrows on the chassis show the true control direction. Before driving the machine, check the following;

3.5.1 DRIVE CONTROLS

The drive controls are located in the cage and consist of a joystick controller and a footswitch. These controls can be seen in figure 3.1 (See page 3-8).

3.5.1.1 Forward and Reverse

- (a) Check that power keyswitch at ground controls is switched to cage position.
- (b) At the cage controls, set the LIFT/DRIVE selector switch to DRIVE.
- (c) Fully depress the footswitch.
- (d) With the footswitch depressed, push the joystick forward to drive the machine forward, or pull the joystick back to drive the machine in reverse.

Note:- These directions are correct when the cage is at the rear of the machine (opposite end to the steered wheels) but will be reversed if the cage is to the front of the machine (see direction decal on main deck)..

Note:- Speed is proportional to joystick lever movement with the maximum speed being pre-set and automatically selected to high or low speed depending on whether the booms are stowed or raised.

OPERATING PROCEDURES

Note:- The steering is not self centring. The orientation of the steer wheels remains fixed until the steer switch is operated.

Note:- Ensure that the maximum travel speed is reduced to 0.75kph when the booms are elevated from the stowed position.

To stop the machine the joystick should be returned to the centre neutral position.

Note:- The machine will not stop instantaneously but will decelerate to a smooth stop whereupon the parking brake will apply.

SHOULD THE NEED ARISE THE MACHINE CAN BE BROUGHT TO AN ABRUPT STOP BY EITHER RELEASING THE FOOTSWITCH OR BY PUSHING THE EMERGENCY STOP BUTTON.

Note:- That in these circumstances all of the controls, including steer control, are inoperative.

OPERATING PROCEDURES



Never drive from a level surface on to a slope at full speed. Always reduce speed to 1 Km/h when approaching a slope.

Note:- Battery life will be optimised by smooth use of all drive controls. Continuing to depress the steer rocker switch when the steer wheels have reached their limit of travel should be avoided as this causes unnecessary battery drain.

Note:- To de-activate the brakes, the footswitch must be depressed and the joystick displaced simultaneously.



Warning:- When descending on a slope it is necessary to move the joystick in the reverse position to offer adequate braking (plugging).

OPERATING PROCEDURES

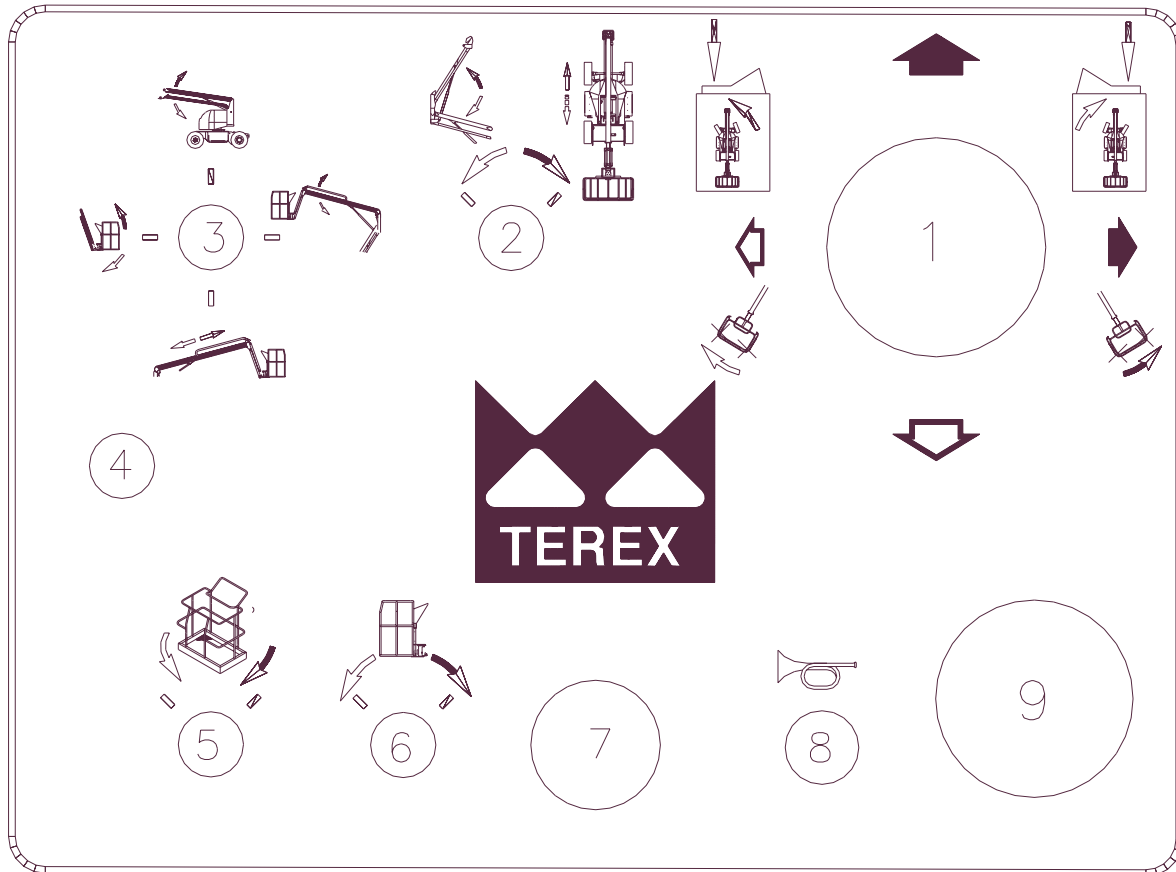

- | | | | |
|----|-------------------------------|----|------------------------------|
| 1) | Joystick | 6) | Cage tilt selector switch |
| 2) | Drive/Boom selection switch | 7) | EMERGENCY STOP push-button |
| 3) | Boom function selector switch | 8) | HORN push-button |
| 4) | Low charge indicator lamp | 9) | Battery Indicator/Hour Meter |
| 5) | Cage rotate function switch | | |

Figure 3.1 - Cage Controls

OPERATING PROCEDURES

3.5.1.2. Drive Speed Control

The drive speed of the machine is proportionally controlled by the amount of movement made to the joystick.

Note:- When elevated, the drive speed of the machine is automatically reduced.

3.5.1.3. Steering Control



**THE WHEELS ARE NOT SELF-CENTRING AND MUST BE ALIGNED BY USING THE JOYSTICK
ROCKER SWITCH**

Steering is achieved by depressing the rocker switch on top of the joystick controller to the left or right, as required.

Note: When ascending a slope with low batteries it is possible that steering will not operate. To steer stop driving and steer as required.

OPERATING PROCEDURES

3.6. BRAKING SYSTEM

The TA34 has a single braking system which serves as a parking brake when the machine is static, and as service brakes when the machine is in drive mode. The brakes are spring applied and hydraulically released.

3.6.1 BRAKES IN STATIC MODE

The machine will not stop instantaneously but will decelerate to a smooth stop whereupon the parking brake will apply.

3.6.2 BRAKES IN DRIVE MODE

The brakes are spring applied when the joystick is in the central (neutral) position and remain applied during lifting operations. Deceleration is achieved by moving the joystick controller to the central (neutral) position.

3.6.3 EMERGENCY BRAKING

Emergency braking is achieved by operating the EMERGENCY STOP button, or by releasing the footswitch.

OPERATING PROCEDURES

3.7. ACCESS OPERATIONS (CAGE CONTROL)

Cage Controls:-

Before entering the cage, the ground controls may be used to bring the cage to the most convenient position for access. The ground controls should, in any case, be checked as follows:

- (a) Ensure that the ground control emergency stop button is out.
- (b) Turn the key in the ground controls power selector switch to select cage control. Remove the key.

The operator may then enter the cage.

- (c) Ensure that the cage control emergency stop button is out.
- (d) Switch lift/drive selector to lift position.
- (e) Select required boom on 4 position boom selector switch.
- (f) Depress footswitch.

Available Control Functions:

- | | | | |
|---------------|--------|---------|---------------------------|
| - Lower Boom: | Up | Down | (Main joystick Y-axis) |
| - Upper Boom: | Up | Down | (Main joystick Y-axis) |
| - Tele-Boom | Extend | Retract | (Main joystick Y-axis) |
| - Fly-Boom | Extend | Retract | (Main joystick Y-axis) |
| - Rotate: | Left | Right | (Main joystick X-axis) |
| - Cage Level: | Front | Back | (Momentary Select Switch) |
| - Cage Rotate | Left | Right | (Momentary Select Switch) |

Note:- The footswitch must be activated at all times during cage access functions.

OPERATING PROCEDURES

3.8. ACCESS OPERATIONS (GROUND CONTROL)

Ground Controls:

Control from the ground is effected as follows:

- (a) Ensure that both ground and cage control emergency stop buttons are in the out (released) "power-on" position.
- (b) Insert the key into the control power selector switch and turn to ground control and hold in position while carrying out the following instructions. (Momentary operation)
- (c) Operate boom motions as required by referring to the control panel diagrams, and turning selection switch in the appropriate direction, hold until required position of booms is reached, all motion will stop once the switch is released.
- (d) When operations at the ground controls are complete turn the power selector switch key to the off position.

OPERATING PROCEDURES

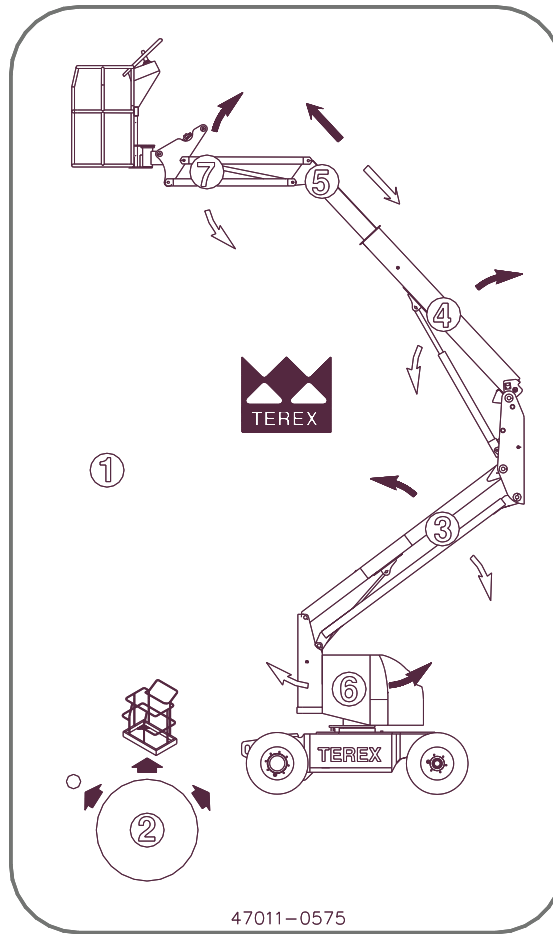

- | | |
|--------------------------------|---------------------------------|
| 1) EMERGENCY STOP push-button | 5) Tele-boom control switch |
| 2) CAGE GROUND selector switch | 6) Plinth rotate control switch |
| 3) Lower boom control switch | 7) Fly-boom control switch |
| 4) Second boom control switch | |

Figure 3.2 - Ground Controls

OPERATING PROCEDURES

3.9. AFTER USE AND STORAGE INSTRUCTIONS

When the machine is no longer required, and is to be stored, the following instructions are recommended.

(Note: Terex Aerials recommends indoor storage of the unit)

- (A) Insure all covers are fitted and secured.
- (B) Bring all booms to stowed position.
- (C) Disconnect all batteries
- (D) Ensure all Emergency Stop Push-buttons are fully depressed.
- (E) Remove all keys from switches.

Prior to re-using the unit after storage, all daily servicing checks (section 5.3.1) should be fully adhered to. After prolonged storage, weekly (section 5.3.2) and monthly (section 5.3.3) servicing checks should also be carried out.

OPERATING PROCEDURES

3.10. BATTERY CHARGING

The TA34 machine is supplied with one of two chargers.

A 48V 25 Amp charger for EU machines only

A 48V 25 Amp charger for US machines only

3.10.1 BATTERY CHARGING ON EU MACHINES

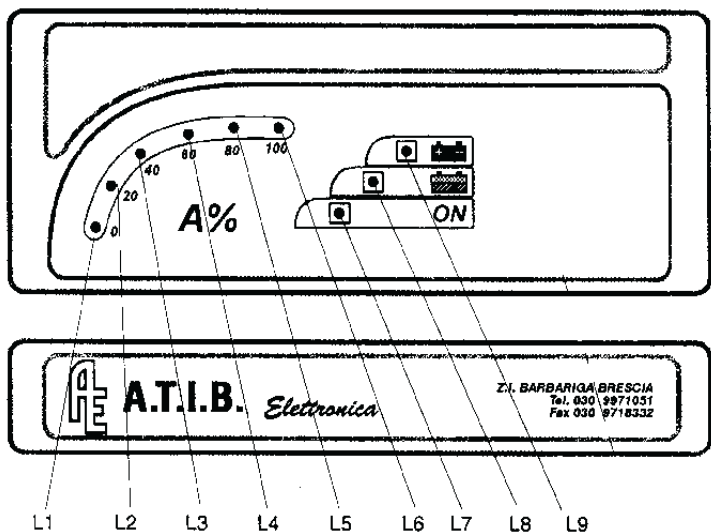

DIODE	COLOUR	FUNCTION
L1	RED	IN WORK
L2-6	RED	SHOWS CHARGING CURRENT IN %
L7	GREEN	BATTERY CHARGER IS SWITCHED ON
L8	YELLOW	BATTERY IS PARTIALLY DISCHARGED
L9	GREEN	BATTERY IS COMPLETELY DISCHARGED

To charge the batteries after they have been fully or partially discharged:

- (a) Press emergency stop button and remove key from lower controls.
- (b) Plug the battery charger lead (on rear of the chassis) into a power supply.
- (c) L7 LED should light to show charger is powered up.
- (d) L8 indicates battery is partially discharged and L9 indicates battery is completely discharged.
- (e) The LED's L2-6 shows charging current.
- (f) The charger will automatically turn off when batteries are charged.
- (g) Machine is fitted with an over-ride to prevent the machine being used while it is being charged.

OPERATING PROCEDURES

3.10.2 BATTERY CHARGING ON US MACHINES

To charge the batteries after they have been fully or partially discharged:

- (a) Press the emergency stop button and remove key from lower controls.
- (b) Plug the charger into an AC power supply having the same ratings as that of the charger (100V 60Hz).
- (c) The LED on the charger will light, indicating charge current is flowing.
- (d) The charger is equipped with an electronic timer. At the battery gassing threshold, (2.3 volts per cell) the timer will activate and run for three hours. During this period, the batteries are in a gassing or equalizing mode (205-206 volts per cell maximum). After three hours the charger will drop the batteries in a low float mode, indicated by a blinking LED. (2.26 volts per cell). Current in the float mode is less than 1 Amp). The charger may be left on indefinitely, but water level should be checked periodically on wet batteries.
- (e) To discontinue charging, unplug the AC power cord. Plugging the AC power back in will cause the charger to repeat the cycle.

OPERATING PROCEDURES

3.11. BATTERY INDICATOR

Important:-

The Battery Discharge Indicator (BDI) is a single piece instrument which combines a battery state of charge indicator with solid state hour meter.

The LED battery displays consists of 5 green, 3 yellow and ‘flashing’ red LED’s. The first red LED will flash when battery is within 10% of lockout discharge level, both red LED’s will flash alternatively at lockout. The LCD hour meter display consists of a flashing hour glass symbol to indicate the hour metre is counting plus six LCD digits to display 99,999.9 hours to the nearest 0.1 hour (six minutes). The hour meter incorporates a custom CMOS/EEPROM chip with a 10 year memory retention.

Machine connection is via a locking terminal connector to internationally available standard. Lift lockout at 80% discharge is effected through a normally closed safety relay. In addition the BDI acts as an ignition warning light. The 10 bar LED of the battery monitor is turned on and off by the key select switch.

It is recommended that the machine is taken out of service as soon as the 2 red flashing LED’s operate flashes and that the batteries are fully charged before any further machine operations are attempted.

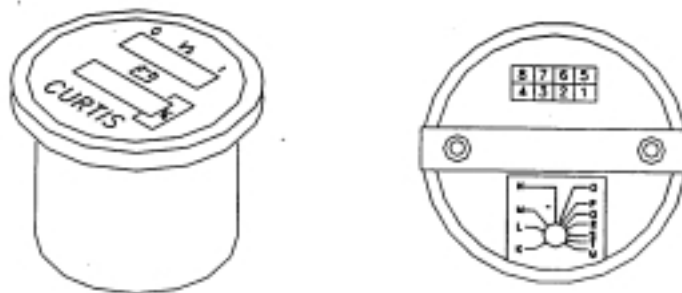

Figure 3.3 - Battery Discharge Indicator

VPC Multiplier

SETTING	K	L	M	N	O	P	Q	R	S	T	U
VOLTAGE PER CELL	1.57	1.63	1.68	1.73*	1.78	1.82	1.84	1.86	1.89	1.91	1.93

*: Factory setting.

When Battery voltage drops below the preselected value, the normally closed contact between 3 and 4 will open. This will eliminate the operation of the boom functions when the machine is in a stowed position.

OPERATING PROCEDURES

3.12. SPECIAL PRECAUTIONS (COLD WEATHER)



BRAKING IN ICY CONDITIONS: WHEN THE GROUND SURFACE IS ICY, CARE MUST BE TAKEN TO AVOID SUDDEN BRAKING. IT IS RECOMMENDED THAT ALL DRIVING OPERATIONS ARE CARRIED OUT SLOWLY AND A SAFE MARGIN OF ERROR IS ALLOWED FOR MANOEUVRING AROUND OBSTACLES. USE JOYSTICK GENTLY TO CONTROL THE MACHINE.

In very cold weather conditions, the hydraulic oil must be allowed to warm before full operation of the machine is attempted. Regular oil maintenance must be carried out to ensure that the hydraulic oil is kept free from water contamination. Emulsified water can freeze out of the oil as ice crystals, completely blocking the suction strainer and causing hydraulic pump damage. To prevent damage to the machine, the following steps should be taken,

- (a) Ensure that all control valves operate smoothly and return freely to the neutral position without sticking.
- (b) Ensure that the rotation drive teeth are not blocked by ice.
- (c) Ensure that the steering linkages are free from ice and that the steering operates smoothly.
- (d) Ensure that the cage floor is free from ice to allow a firm foot-hold without danger of slipping.

OPERATING PROCEDURES

3.13. SPECIAL PRECAUTIONS

3.13.1. TOWING

Machine can be towed by slinging chains around suitable support points. Do not exceed 5km/hr while towing the machine, as wheels may not camber correctly and the traction motor could be damaged.

3.13.2. WIND CONDITIONS

The unit must not be operated in wind speeds which are in excess of 12.5m/sec (28 mph- 45 km/hr). During normal machine operations, consideration should be given to nearby objects, especially when working in the close vicinity of buildings and electrical cables. Sudden gusts of wind could cause the machine to sway and trap the operator's arms/hands between the cage railing and any obstruction. It is recommended that a reasonable safe distance is kept between close obstructions and the cage assembly during all machine operations.

3.13.3. CRANE OPERATIONS

The TA40 is fitted with four lifting points in the form of eyes at each corner of the chassis. During lifting operations, take all instructions from the crane operator. Check identification plate.

3.13.4. DRIVING ON SLOPES



Caution:- To prevent damage to the drive motor, do not exceed the specified speeds when driving on slopes. When moving down slope move stick in reverse direction to motion to offer braking (plugging).

The operator must ensure that speeds are kept within the limits of 5 km/hr (3mph) with booms stowed and 0.75 km/hr (0.5 mph) with booms elevated.

OPERATING PROCEDURES

3.13.5. TESTING THE TILT ALARM



IF THE TILT ALARM SOUNDS WHILST ELEVATED, RETRACT AND LOWER BOOMS AND DRIVE TO A LEVEL LOCATION.

If a wire in the tilt alarm circuit becomes disconnected whilst the machine is in use, the alarm will sound continuously. If this occurs when the machine is elevated, zoom in immediately and lower the cage to the stowed position. **DO NOT USE THE MACHINE UNTIL THE FAULT HAS BEEN RECTIFIED.**

With key switched on and before you operate the machine, open rear cover and press down one side of sensor. This will sound the horn after a small time delay, if functioning properly.

If there is no horn sound, the sensor must be repaired immediately before machine can be operated.

EMERGENCY PROCEDURES

4.1. EMERGENCY PROCEDURES

It is not possible for us to foresee every emergency situation that could arise during operation of this machine. Information on the following pages describes three typical emergency situations and lists appropriate actions that can be taken.

When faced with an emergency, above all please remember:

Stay Calm.

Think through the situation before operating the machine.

Get help if necessary.

4.1.1 **SITUATION: Platform elevated, operator not incapacitated, but unit will not operate using the platform controls.**

POSSIBLE CONDITION:

One or more functions not operating correctly.

Unit movement from unselected control lever or switch.

Unit function will not stop unless power is switched off.

CORRECTIVE ACTION:

Remove foot from foot switch.

Evaluate the nature of the failure.

Switch to ground controls and operate.

If unable to return to the ground using the ground controls, contact an experienced operator to lower the machine using the emergency pump and lowering procedure (see "Emergency Pump" section 4.2.1).

Report the incident to your supervisor immediately.

EMERGENCY PROCEDURES

4.1.2 **SITUATION: Unit elevated, with operator incapacitated at platform controls.**

TRY TO DETERMINE THE CAUSE OF THE PROBLEM BEFORE YOU TOUCH THE MACHINE.

CORRECTIVE ACTION:

Have someone summon first aid or rescue squad.

Attempt to talk to the operator before taking any rescue measures.

Before attempting emergency lowering procedure, check to see if the operator is:

- a) in a pinned situation, or
- b) would be endangered if platform is moved.

After establishing that the machine is not in contact with live power lines, lower the platform or move the unit as necessary, using emergency procedures (see "Emergency Pump", section 4.2.1).

Render first aid to the operator.

Report the incident to your supervisor immediately.

IMPORTANT: Any incident involving personal injury must be immediately reported to the local Terex Aerials Distributorship as well as to Terex Aerials Inc.

4.1.3 **SITUATION: Platform in contact with live power lines and operator incapacitated.**

CORRECTIVE ACTION:

Have someone summon first aid or rescue squad.

Contact authorised personnel to disconnect power supply touching unit.

Before attempting emergency lowering, check to see if the operator is:

- a) in a pinned situation
- b) would be endangered if platform is moved.

AFTER POWER IS CUT, lower the platform or move the unit as necessary, using emergency procedures (see "Emergency Pump", section 4.2.1).

Render first aid to the operator.

Report the incident to your supervisor immediately.

IMPORTANT: Any incident involving personal injury must be immediately reported to the local Terex Aerials Distributorship as well as to Terex Aerials Inc.

EMERGENCY PROCEDURES

4.2 EMERGENCY SYSTEMS AND PROCEDURES

4.2.1 EMERGENCY PUMP

This machine has an emergency hand pump which can be used from the ground control station to operate the machine when the unit has lost power. The hand pump is located under the valve block. The lever is stowed in the plinth.

EMERGENCY OPERATION:

Insert handle into handpump (located on rear of plinth).

Through the aperture in the turn table cover, turn the knob (clockwise) on the desired function until the spool is shifted (knob stops turning)..

Operate the hand pump until the boom reaches the desired position. Repeat for each boom function.

Return each knob to its original position after use. (Turn counter clockwise fully).

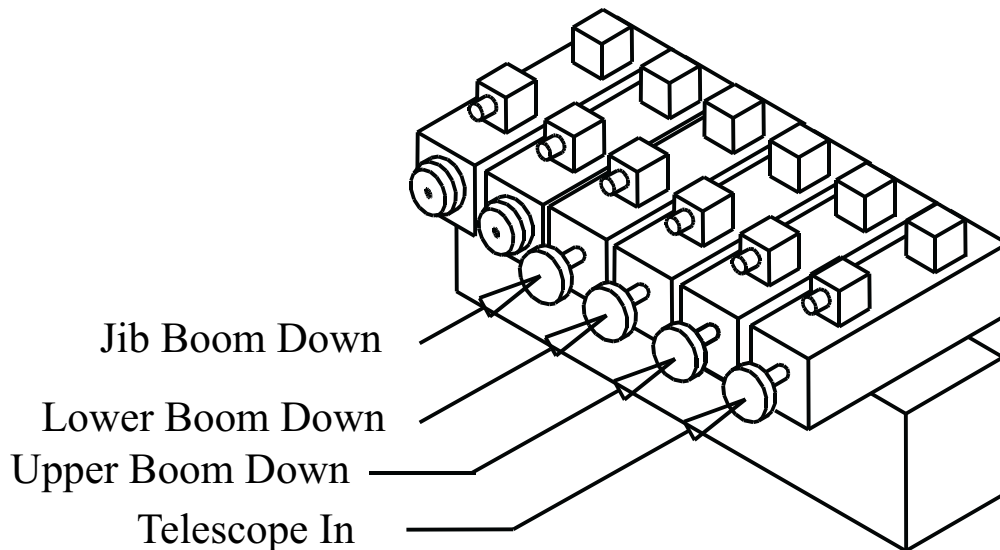

Figure 4.1 - Hydraulic control valve block

4.2.2 EMERGENCY ROTATION

The emergency rotation of the superstructure can be performed by either mechanical override or the emergency pump.

For the mechanical override procedure, use 1/2" square socket, extension and ratchet handle attached to the square extension shaft of the rotate drive gearbox.

For the emergency pump procedure, activate the emergency pump and select the screw override.

EMERGENCY PROCEDURES

4.2.3

EMERGENCY TOWING



The machine is not designed for sustained towing but may be towed over short distances, at low speed, should the need arise.

In order to tow the machine it is necessary to disengage the transmission. Doing this also disconnects the brakes so it is essential that the machine is first secured to prevent injury or damage.

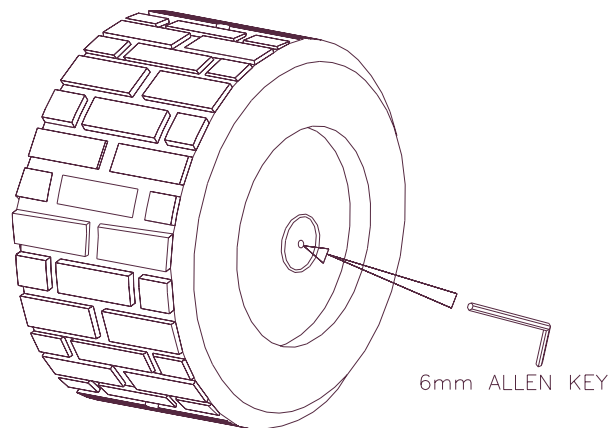

Figure 4.1 - Disengaging and Re-engaging the Transmission

To disengage the transmission and brakes it is necessary to screw the Disengage Plug fully in using of a 6mm hexagon (Allen) key, turning it clockwise (as in Figure 4.1)

To re-engage the transmission, the same plug is screwed anti-clockwise, until it is fully out.

Having disengaged the transmission the machine may be moved using a suitable vehicle or winch, pulling the machine from the slinging eyes on the chassis.

NOTE: At no time should the speed exceed 5 km/hr, (3 mph).

On downhill slopes it may be necessary to use a further vehicle to prevent run away.



It is very important that the transmissions is fully re-engaged otherwise the gear box will be damaged.

EMERGENCY PROCEDURES

4.3 EMERGENCY LOWERING

4.3.1 EMERGENCY LOWERING FROM GROUND

Emergency lowering may be necessary in the unlikely event of a power failure or due to failure of the cage controls.

The ground controls should be tried first and only if these are also inoperative should the emergency lowering system be used.

When using the emergency lowering system, the lower boom should be lowered first as follows:-

Select lower boom override on manifold block

Pump emergency hand pump

After lowering the lower boom the other booms may be lowered in the same way, by selecting the desired function.

NOTE: DESELECT THE PREVIOUS FUNCTION BEFORE SELECTING THE NEXT (unscrew selection knob)

NOTE: That if emergency lowering is necessary due to pump or hose failure but the controls themselves remain operative then it is possible to lower the booms using the emergency hand pump in conjunction with either the upper or lower controls as follows:

- (a) operate the emergency hand pump as before.
- (b) operate from the chosen control position as normal choosing only downward, inward and slewing functions.



CAUTION: If a machine fault necessitates the emergency lowering of the unit then the platform must be examined by a fully trained technician before the machine is returned to service.

DO NOT USE THE PLATFORM UNTIL IT HAS BEEN ESTABLISHED WHY THE EMERGENCY FUNCTIONS HAD TO BE USED.

MAINTENANCE SCHEDULES

5.1. GENERAL INFORMATION

5.1.1. INTRODUCTION

The TA34 has been specially designed to reduce maintenance to a minimum. It is essential that the specified servicing instructions are followed to ensure safety and reliability.

The hydraulic pump, motor, cylinders and pressure valves are self-lubrication internally. The turntable slewing ring is grease packed and the corrosion-resistant pivot pins and bearings are pre-lubricated and require attention only at six monthly intervals.

Note:- During the guarantee period, minor oil leaks may occur until the various hydraulic components and pipe fittings are “bedded-in”. During the first three months of operational use, all hydraulic components, hoses and pipe fittings must be inspected weekly for oil leaks etc. Corrective action should be taken as required.

5.1.2. HYDRAULIC OILS

The following table lists the recommended equivalent hydraulic oils for a TA40 machine

SHELL	SHELL TELLUS T32
MOBIL	DTE 13M
TEXACO	RANDO HDZ 32
CASTROL	HYPIN AWH 32
ESSO	UNIVISE N32

If a lubricant not listed in the table is to be used, the oil must comply with the following requirements:-

- (a) Highly refined mineral oil incorporating anti-oxidant, anti-dust, anti-foam, and anti-wear additives.
- (b) The oil must have good demulsibility, so that water is not circulated in the system.
- (c) The optimum viscosity range at operating temperature is 16/40 centi Stokes.
- (d) The viscosity index should preferably be 100, and not less than 90.

MAINTENANCE SCHEDULES

(e) the viscosity range will usually be:

Temperate	0°C	-	300cSt
Temperate	40°C	-	30cSt
Tropical	0°C	-	700cSt
Tropical	40°C	-	50cSt
Tropical	100°C	-	8cSt

(f) Mineral hydraulic oils produced by different companies will usually mix with each other satisfactorily. However, the oil producers should be consulted in case of doubt.

(g) For sub-zero temperatures, the use of Shell Tellus T15 or equivalent hydraulic fluid with viscosity index of 151E and pour point MINUS 50°C is recommended.

(h) For tropical temperatures, the use of BP Energol HLP 100 or equivalent is recommended.

HEALTH WARNING WHEN HANDLING HYDRAULIC OILS



REGULAR CONTACT WITH MINERAL OILS POSES A POTENTIAL HAZARD TO HEALTH. ALL PERSONS MUST BE AWARE OF THE CORRECT METHODS OF HANDLING THE OIL AND THE NEED FOR THOROUGH HYGIENE.

Mineral oil act as solvents on the natural oil in the skin. Frequent and prolonged skin contact can cause dermatitis or severe irritation. Normally, mineral hydraulic oils present no health hazard when used intelligently and it is recommended that protective clothing and proper washing facilities should be provided or be accessible.

If oil is splashed into the eyes, it must be washed out thoroughly using copious quantities of water. If irritation persists, medical advice must be sought.

MAINTENANCE SCHEDULES

5.2. SERVICING CHECK LIST (BASIC MACHINE ONLY)

All checks must be completed by operator before operating unit.

5.2.1. DAILY

- (a) Check hydraulic oil level (in power pack reservoir).
- (b) Check Tyre condition.
- (c) Check for hydraulic leaks.
- (d) Check hoses for chaffing.
- (e) Check that safety harness points are intact.
- (f) Check tilt alarm.
- (g) Check that all switches are not damaged.
- (h) Check cage controls for proper operation.
- (i) Check wheel nuts for tightness.
- (j) Check wheels for damage.

MAINTENANCE SCHEDULES

5.2.2 WEEKLY

In addition to the daily checks, the following checks should be carried out by an experienced technician :-

- (a) Inspect hydraulic system for leakage.
- (b) Check steering system for oil leakage and wear.
- (c) Check battery electrolyte levels.
- (d) Check pivot pin security.
- (e) Lubricate slew ring gear teeth.
- (f) Check the nylon zoom pads for wear as follows:-
 - (i) Fully zoom in and check the gap at the top of the zoom boom telescope, between the inner and the outer, at the rear of the zoom boom.
 - (ii) Fully zoom out and check the same gap at the top of the telescope, at the front of the zoom outer.
 - (iii) Renew the pads if the gap between the pad and the zoom outer is 5mm or more.
- (g) Grease cylinder pivot pins, steering pivot pins and slew ring (Figure 5.2, see also section 5.4).
- (h) Check wheel drive unit oil level.
- (i) Check rotation box securing bolts for tightness.
- (j) Ensure all labels are legible and in place.
- (k) Check all hoses and cables through slew ring for wear.
- (l) Check the manifold assembly. Operate the motor and carry out the following checks:-
 - (i) Check the security of blocks and solenoids.
 - (ii) Check the security and condition of hoses and cables.
- (m) Check the hydraulic oil tank as follows:-
 - (i) Check the tank for security
 - (ii) Check the tank for leakage.
 - (iii) Check that the hand pump is operational by screwing in one of the Manual Overrides and pumping the handle (remember to screw out when complete).
- (n) Check the battery and mountings as follows:
 - (i) Check the battery and mounting frame for signs of damage.
 - (ii) Check battery terminals for corrosion. Clean and apply Vaseline to terminals.
 - (iii) Check the battery electrolyte level and, if necessary, top-up with distilled or de-mineralised water.
- (o) Check the minor equipment as follows:-
 - (i) Check all minor equipment for security.
 - (ii) Check for oil leakage.
 - (iii) Check all cables for security and damage.

MAINTENANCE SCHEDULES

5.2.3 MONTHLY

In addition to the weekly checks, carry out the following:-

- (a) Check for hydraulic oil contamination.
- (b) Check chassis mounting bolts.
- (c) Lubricate all small pivots throughout the machine.
- (d) Check rotation gearbox oil level.
- (e) Ensure all boom/cylinder pins are positively secured in position.
- (f) Torque wheel nuts to that specified in the torque chart (Ref. Figure 2.1)
- (g) Check structure for any obvious defects.
- (h) Check condition of the slave cylinder.
- (i) Check all bushes for wear. Elevate the booms and check each pin in turn for rotation or movement. If wear is detected, the bush may need to be replaced.

The pins and bushes have been specially treated and should only require lubrication at 4 yearly intervals. Under certain conditions, lubrication may be required more frequently.

- (j) Check the slew bearing for any obvious defects. Generally, no user maintenance to the slew bearing is possible. The replacement of the slew bearing is a major operation and advice should be sought from Terex Aerials Ltd. Checks must be made to ensure that all securing bolts are tight. Any bolts found loose or sheared must be replaced. Slew ring play is measured at the perimeter of the ring, the maximum rock allowed is 1.7mm (Refer to Figure 5.1)
- (k) Check and maintain the superstructure as follows:-
 - (i) Steam clean the superstructure and inspect all welds and brackets.
 - (ii) Check for pins turning in their mountings. This will indicate sheared pin lock bolt. Refer to pin replacement procedures.

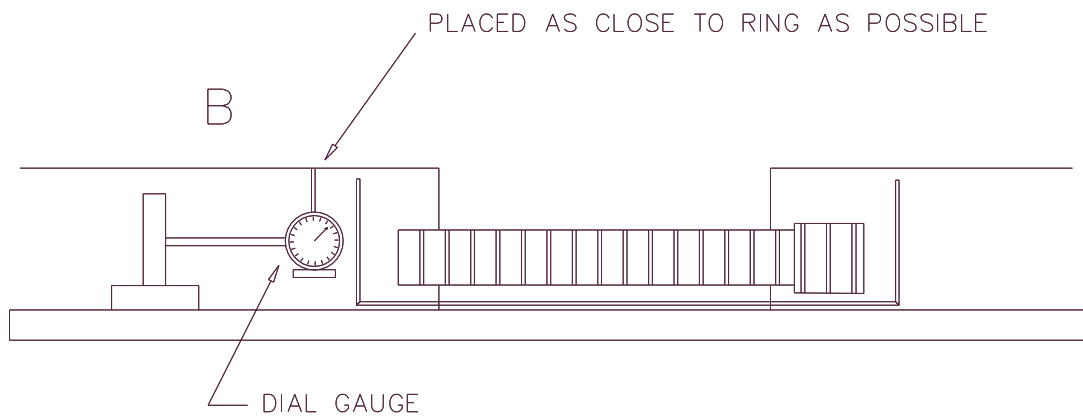

Figure 5.1 : Slew Ring Bearing Play Measurement

MAINTENANCE SCHEDULES

5.2.4 SIX MONTHLY

In addition to the monthly check, carry out the following:-

- (a) Check cage levelling.
- (b) Check cage pivots.
- (c) Check boom cylinders. The lift cylinder seals can be replaced with the cylinder mounted on the machine, or by removing the cylinder before removing the seals.
- (d) Replace hydraulic oil filter element.
- (e) Test all machine systems.

MAINTENANCE SCHEDULES

5.2.5 YEARLY

In addition to the 6 monthly check, carry out the following:-

- (a) Check zoom cylinders. The zoom cylinder is a double-acting type and must be removed from the machine before any thorough check can be carried out.
- (b) Grease slewing ring bearing.
- (c) Examine the hydraulic oil. Change if necessary.
- (d) Check hydraulic oil tank.
- (e) Examine machine structure for defects.
- (f) Examine cage mountings and structure.

5.2.6. FOUR YEARLY

In addition to the yearly checks, carry out the following.

- (a) Detailed examination of flexible hoses.
- (b) Detailed examination of all pivot pins and bearings.

MAINTENANCE SCHEDULES

5.3. SERVICING

Servicing to be carried out by a trained technician.

5.3.1 DAILY ROUTINE SERVICING

5.3.1.1. Hydraulic Oil Level

Before checking the oil level, ensure that the machine booms are stowed in the travelling position and the machine is standing on level ground. The oil level must be visible on the dip stick. Refer to the lubrication chart for the correct grade of oil if the reservoir requires topping up.

After checking the oil level, ensure the oil filler cap is fully secure to prevent water contamination or contamination by other impurities .

5.3.1.2. Tyre Condition

Check the condition of all four tyres.

5.3.2. WEEKLY ROUTINE SERVICING

5.3.2.1 Hydraulic System

Inspect the hydraulic system as follows:-

- (a) Pressurise the hydraulic circuit and inspect the system for any signs of oil leakage, particularly at flexible hoses, connections and hydraulic components.
- (b) Examine all pivot pins on booms, cylinders and the levelling system to ensure that they are positively secured in position.

5.3.2.2. Steering

Check the steering cylinder for oil leakage and the linkage for signs of wear.

MAINTENANCE SCHEDULES

5.3.2.3. Pivot Pins

Check all pivot pins for security. Grease those pivot pins as shown in Fig 5.2.

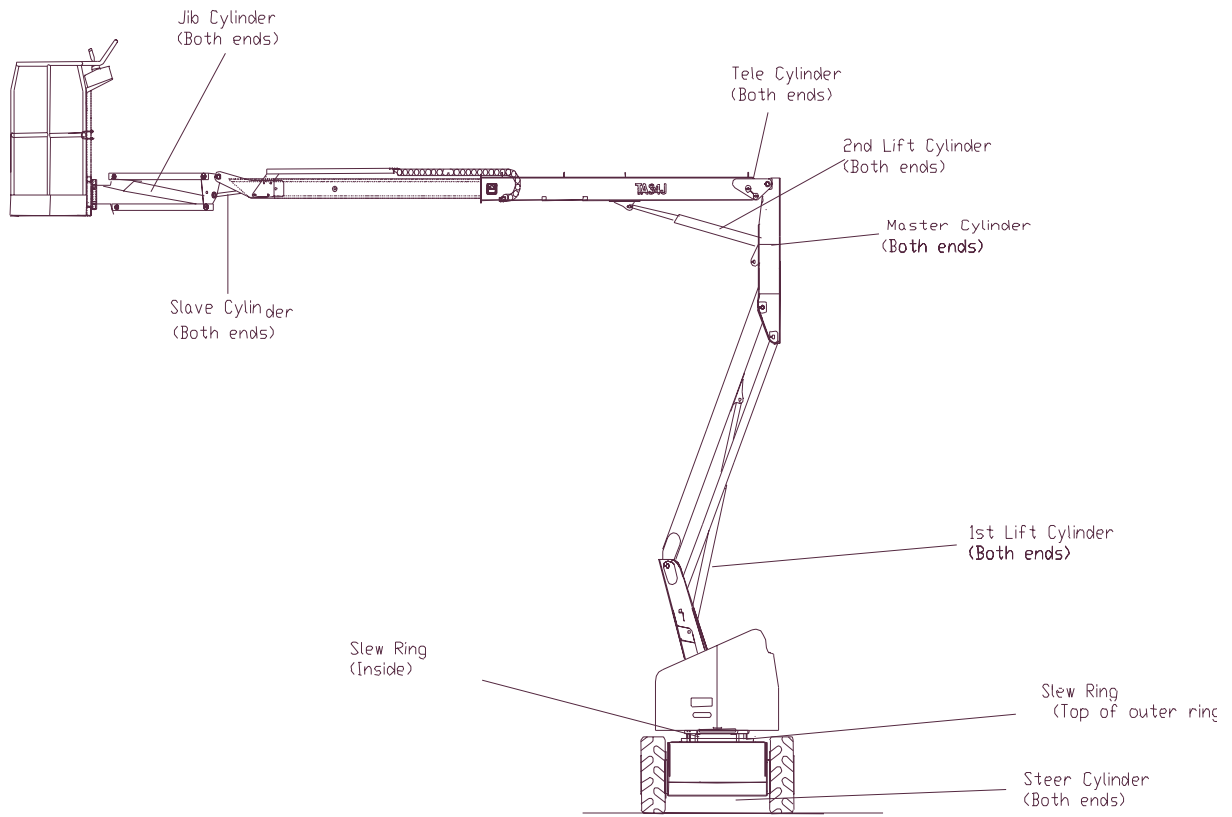

Figure 5.2 - Location of Grease Nipples

MAINTENANCE SCHEDULES

5.3.3. MONTHLY ROUTINE SERVICING

5.3.3.1. Chassis Bolts

Check all bolts for tightness.

5.3.3.2. Slewing Ring Gear Teeth

Remove any dirt from between the gear teeth and lubricate.

Note:- If solvents or a high-pressure washer are used for cleaning, re-grease the slewing ring bearings.

5.3.3.3. Lubrication

Lubricate all small pivots throughout the machine with any good quality medium grade oil.

5.3.3.4. Pivot Pin Security

Examine all pivot pins on booms, cylinders and levelling system and ensure that they are all positively secured in position.

MAINTENANCE SCHEDULES

5.3.4 SIX MONTHLY ROUTINE SERVICING

5.3.4.1. Cage Levelling

Check the cage levelling system as follows:-

- (a) Examine both levelling cylinders, particularly at the pivot points, for any sign of wear or damage. Ensure that the end fittings are secure.
- (b) Check cylinders and hose fittings for leaks.

5.3.4.2. Boom pivots

The main pivots on the booms, cylinders and levelling system are fitted with corrosion-resistant pins and per-lubricated bearings. Check the bushing for any signs of wear

The bushings are steel-backed, acetal co-polymer lined. If the bearings show any defect, they should be replaced with the correct type. Consult Terex Aerials Ltd.

5.3.4.3. Boom Cylinders

Check the boom cylinders as follows:-

- (a) Hydraulically test the cylinders at fully retracted and extended positions, Check that there is no movement between rod and bearing housing, or between cap and tube
- (b) Check all cylinders for oil leakage.

5.3.4.4 Drive Hubs

Check the oil level in the axle with the machine on level ground and, if necessary, top us with EP 90 oil.

5.3.4.5. Pressure Line Filter

Change the Pressure Line Filter element.

5.3.4.6. Machine Systems Test

Test the following systems:-

- (a) Drive motor.
- (b) Slewing ring.
- (c) Cage rotation worm drive.
- (d) All machine functions.

MAINTENANCE SCHEDULES

5.3.5 YEARLY ROUTINE SERVICING

5.3.5.1 Hydraulic Oil

Providing the hydraulic oil has been regularly maintained, it should only require changing at approximately two-yearly intervals. This is dependent on maintenance, amount of use, application, temperature, atmospheric conditions and other factors.

A cloudy appearance in the hydraulic oil indicates that water is present. A change from clear amber to dark brown, accompanied by a strong "burnt" smell, indicates overheating of the oil. The cause should be investigated and rectified. The presence of either requires a complete drain and refill of the entire hydraulic system.

5.3.5.2. Hydraulic Oil Reservoir

Carefully check the condition of the oil inside the reservoir to ensure that it flows easily and is a clear amber colour. In cases of gross contamination, it will be necessary to completely drain and refill the entire hydraulic system.

5.3.5.3. Hydraulic Reservoir Refill Procedure

Refilling the hydraulic oil tank requires approximately 13 litres of TEXACO RANDO HDZ 32 hydraulic oil (or equivalent). To refill the hydraulic tank, proceed as follows:-

- (a) Ensure that the oil temperature is sufficiently high to allow the oil to flow freely.
- (b) Place a suitable container under the drain tap or attached to a suitable hose to lead from the drain tap to the waste oil container.
- (c) Remove drain plug.
- (d) Remove the filler breather cap for internal inspection and cleaning.
- (e) Renew or clean the suction hose and replace drain plug.
- (f) Replace the filler breather cap.

5.3.5.4. Structural Examination

A thorough examination of the complete machine should be carried out for any signs of damage, corrosion, misalignment, material fractures, etc. Particular attention must be given to the condition of all welded joints.

5.3.5.5. Cage Mounting

Check the cage mounting as follows:-

- (a) Check that all mounting bolts are secure.
- (b) Check cage frame members are in good condition.

5.3.5.6. Levelling Cylinders

Check seals at rod and if in need of replacement change.

MAINTENANCE SCHEDULES

5.3.6 FOUR YEARLY ROUTINE SERVICING

Note:- The following recommendations are based on the advice of suppliers and the requirements of various national safety regulations. They should be applied with discretion, depending on such factors as the amount and type of use, environmental conditions, local safety regulations etc.

5.3.6.1. Flexible Hoses

Inspect all flexible hoses over their complete length. Renew any hoses showing looseness or corrosion at the end fittings, cracking, blistering or excessive wear of outer protective covering.

5.3.6.2. Pivot Pins and Bearings

All pivot pins have been treated with Tuffrite and only require lubrication checks at 4-yearly intervals.

All pivot pin bearings are steel-backed, acetal co-polmer lined and only require lubrication checks at 4-yearly intervals.

Note:- In tropical climates, pins and bearings may require more frequent lubrication.

The recommended lubricant for pivot pin bearings is MALACHITE LONGTERN 2 PLUS extreme pressure grease or equivalent.

Note:- There are no grease nipples for Boom pin bearing lubrication. The pins must be removed and lubricated by hand.

Cylinder pins are lubricated by greased nipples. These should be greased weekly or every 100 hrs.

5.3.6.3. Pin Replacement

To replace a pin, the following procedures should be adhered to,

5.3.6.3.1. Boom Pin Replacement

To replace a boom pin, proceed as follows;-

- (a) Support the boom and upper structure securely on a fork lift, or similar rigid platform.
- (b) Remove the pin locking bolts, pull out the buck pin.
- (c) Drive out the boom pin. Take care to ensure that the inside bore is not damaged during this procedure.
- (d) Fit new pin and refit buck pin and locking bolt. Lubricate the bolts before fitting.

Note:- It is very important to maintain the correct mating position between the boom and side plates during this operation. Any movement between the two parts will make pin fitting more difficult.

- (e) Apply grease to pins.

MAINTENANCE SCHEDULES

5.3.6.3.2 Tie-Rail Pin Replacement

To replace a tie-rail, proceed as follows;

- (a) Support the tie-rail securely on a fork lift, or similar rigid platform. Or tie to adjacent boom.

Note:- On removal of the pin, the tie-rail will fall from position if not held. Since the tie-rail is a relatively light components, it can be held in position manually while the new pin is fitted.

- (b) Remove the pin locking bolt, pull out the buck pin.
- (c) Drive out the boom pin. Take care to ensure that the inside bore is not damaged during this procedure.
- (d) Apply grease to the pin.
- (e) Fit new pin and refit buck pin and locking bolt. Lubricate the bolts before fitting.

5.3.6.3.3. Lift Cylinder Pin Replacement

To replace lift cylinder pin, proceed as follows:-

- (a) Support the Boom. Release the oil pressure to ensure there is no load on the cylinder.
- (b) Remove the pin locking bolts, support the cylinder and remove the pin.
- (c) Fit new pin and pin locking bolts. Lubricate the bolts before fitting.
- (d) Apply grease to the grease nipple lubricate the pin.

5.3.6.3.4. Self Levelling Cylinder Pin Replacement

To replace a self levelling cylinder pin, proceed as follows:-

- (a) Support the cage to ensure that there is no load on the self levelling cylinders. This also applies when changing pins on the rear levelling cylinder.
- (b) Remove the buck pin and its locking bolt and drive out the pin.
- (c) Fit new pin and replace the buck pin and its locking bolt. Lubricate the bolts before fitting.
- (d) Apply grease to the grease nipple lubricate the pin.

5.3.6.3.5. Zoom Boom Cylinder Pin Replacement

To replace a zoom boom cylinder pin, proceed as follows:-

Note:- If the zoom has been greased, the location recess may be filled and not visible.

- (a) Remove the pin locking bolts.
- (b) Support the cylinder and remove the pin. When changing the rod pin, it may be necessary to zoom out to reveal the pin location. This pin is held by two Circlips, one of which needs to be removed before the pin can be driven out.
- (c) Fit new pin and replace buck pin and locking bolt. Lubricate the bolts before fitting.
- (d) Apply grease to the pin.

MAINTENANCE SCHEDULES

5.3.6.4 Zoom Cylinder

Check condition of cylinder as follows:

- a) Remove the pins and hoses.
- b) Withdraw the cylinder backwards out of the zoom boom.
- c) Elevate the zoom boom to the horizontal position.

Note:- The zoom boom must be secured fully in to prevent the zoom inner from sliding out without the constraint of the zoom cylinder.

5.3.6.5 Zoom Pads

Zoom pads should be replaced as follows, depending on the type of pad:

5.3.6.5.1. Front Zoom Pad Replacement

To replace the front zoom pads, proceed as follows:-

- a) Support the inner zoom boom. Unscrew the pad holding screws and pull pads out of boom.
- b) Replace the pads by tapping gently into place.
- c) Replace holding screws and tighten into position.

5.3.6.5.2. Rear Zoom Boom Replacement

To replace the rear zoom pads, proceed as follows:-

- a) Extend the inner zoom boom until the front mount of the Tele-cylinder is accessible.
- b) Remove one Circlip from end pivot pin, drive out pin.
- c) Pull the inner boom backwards, until the pads are accessible at the rear of the zoom boom.
- d) Replace the pads and re-assemble the inner zoom boom in the reverse order.

5.3.6.6 Lift Cylinder Seals

Should the lift cylinder seals be damaged, they can be replaced as per the the following sections.

MAINTENANCE SCHEDULES

5.3.6.6.1 Seal Replacement - Cylinder In-place

To replace the lift cylinder seals without removing the cylinder from the machine, proceed as follows:-

- (a) Support the boom and release the cylinder pressure.
- (b) Clean the cylinder end and loosen the cylinder end cap. Undo the end cap several turns.
- (c) Remove the rod end pin and support the cylinder barrel. Undo the end cap end and withdraw it carefully over the piston rod. Take care to ensure that no dirt enters the system.

Note:- It is recommended that the bearing ring at the base of the piston rod is replaced when seals are replaced. Examine the rod of score marks and damage. This is most easily achieved by extending the cylinder and examining the protruding rod.

- (d) Replace the seals in the end cap and replace the end cap. Care should be taken during this procedure to ensure that no damage occurs to the rod surface.
- (e) Bleed the cylinder by allowing air to escape around the end cap threads.
- (f) Fully tighten the end cap.
- (g) Clean the over-centre valves and examine for signs of leakage.
- (h) Check for efficiency, by extending the cylinder and selecting descent, via the spool valves at either cage of ground.

5.3.6.6.2 Seal Replacement - Cylinder Removed

The cylinder can be removed from the machine before replacing the seals. The replacement procedure is the same as that detailed in section 5.3.6.6.1.

MAINTENANCE SCHEDULES

5.4 LUBRICATION

5.4.1 GENERAL LUBRICATION

The following table lists the recommended lubricants for the TA40:

<u>COMPONENT</u>	<u>LUBRICANT</u>	<u>FREQUENCY</u>	<u>REMARKS</u>
Drive Gearbox	EP 90	Check monthly Change yearly	
Starter Battery Terminals	Vaseline	Grease 6 monthly	Smear Electrical connections
Hydraulic Oil	TEXACO RANDO HDZ 32 or equivalent - refer to section 1	Check weekly Change yearly	Fill to 1 inch (2.54cms) below top of dip stick
Pins/Bearings	Molykote 2	Grease 4 yearly	Grease more freq. in tropical climates.
Wheel Bearings	LS 2	Grease Yearly	
Zoom Boom (Inner)	Molykote 2	Grease monthly	
Zoom Boom (Outer)	WD 40	Monthly	
Slew Ring	EP2	Refer to section 5.4.2.1	

MAINTENANCE SCHEDULES

5.4.2 Slew Bearing/Gear Lubricants

5.4.2.1. Slew Bearing Lubrication

Terex Aerials recommends lubrication of the slew bearing with an EP2 grease.

The slewing rings are equipped with greasing holes tapped to the European standard and suitable for:

- Centralised greasing.
- Standard greasing; straight or angled spherical head grease nipples
(AFNOR norms NFR 165-21 - DIN 3410)

Lubrication Frequency - Slew Bearing

- Regular Operation every 100 hours
- Intensive Operation every 50 hours

Note:- The slewing ring should be rotated through 360° after the lubrication operation and the lubricants should then be topped up.

5.4.2.2. Slew Gear Lubrication

The teeth must be thoroughly cleaned, particularly within the gaps between the teeth, before lubrication. For this operation we recommend a proprietary solvent.

Use a suitable caulking gun to apply a 6 mm diameter bead of grease around the full circumference of the gear. Brush the grease into the gear surfaces.

Lubrication Frequency- Slew Gear

- Approximately 50 hours.

Grease Characteristics - Slew Gear.

The grease used on the slew gears must comply with the following characteristics:

- Extreme pressure grease.
- Water and temperature resistant.
- Temperature range25° F to 400° F (-4°C to 200° C)

Terex Aerials Limited recommend the following grease for the slew gear.

- **KEYSTONE MOLY 25 OPEN GEAR COMPOUND (S.A.Part No. 10126400)**

It is possible to use other brands of grease provided that they offer greasing characteristics similar to the type listed above.