

1140138 - 1140143      1140144 - 1140149      1140156 - 1140161

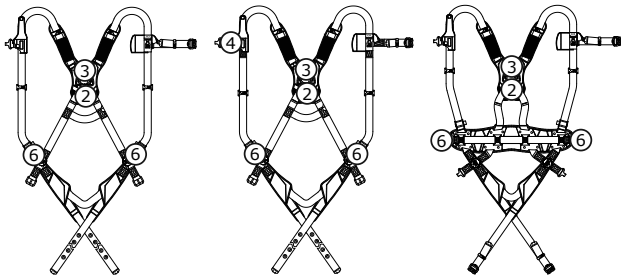

1140162 - 1140167      1140168 - 1140173      1140180 - 1140185

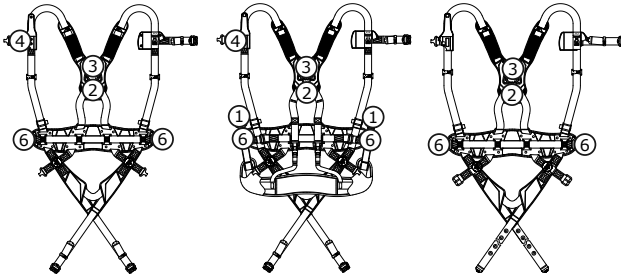

1140186 - 1140191      1140192 - 1140197      1140198 - 1140203

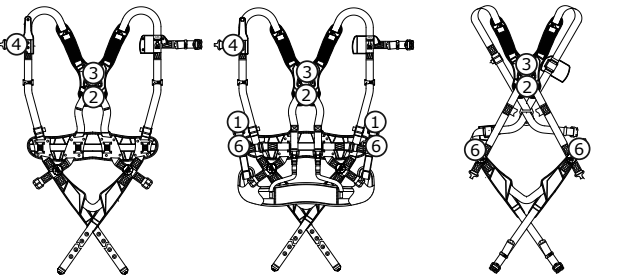

Models	Crossover	XS	SM	MED	LG	XL	2XL	①	②	③	④	⑤	⑥	⑦	⑧	⑨	⑩
								Suspension Seat	EZ-Link	Dorsal	Sternal	Shoulder	Hip	Quick Connect	Tongue Buckle	Shoulder Pads	Belt & Hip Pad
	Size						Attachment Elements				Buckles		Pads				
1140145			✓					✓	✓	✓		✓		✓	✓		
1140146				✓				✓	✓	✓		✓		✓	✓		
1140147					✓			✓	✓	✓		✓		✓	✓		
1140148						✓		✓	✓	✓		✓		✓	✓		
1140149							✓	✓	✓	✓		✓		✓	✓		
1140156		✓						✓	✓	✓				✓	✓	✓	✓
1140157			✓					✓	✓					✓	✓	✓	✓
1140158				✓				✓	✓					✓	✓	✓	✓
1140159					✓			✓	✓					✓	✓	✓	✓
1140160						✓		✓	✓					✓	✓	✓	✓
1140161							✓	✓	✓					✓	✓	✓	✓
1140162		✓						✓	✓	✓				✓	✓	✓	✓
1140163			✓					✓	✓	✓				✓	✓	✓	✓
1140164				✓				✓	✓	✓				✓	✓	✓	✓
1140165					✓			✓	✓	✓				✓	✓	✓	✓
1140166						✓		✓	✓	✓				✓	✓	✓	✓
1140167							✓	✓	✓	✓				✓	✓	✓	✓
1140168		✓						✓	✓	✓	✓		✓	✓	✓	✓	✓
1140169			✓					✓	✓	✓	✓		✓	✓	✓	✓	✓
1140170				✓				✓	✓	✓	✓		✓	✓	✓	✓	✓
1140171					✓			✓	✓	✓	✓		✓	✓	✓	✓	✓
1140172						✓		✓	✓	✓	✓		✓	✓	✓	✓	✓
1140173							✓	✓	✓	✓	✓		✓	✓	✓	✓	✓
1140180		✓						✓	✓						✓	✓	✓
1140181			✓					✓	✓						✓	✓	✓
1140182				✓				✓	✓						✓	✓	✓
1140183					✓			✓	✓						✓	✓	✓
1140184						✓		✓	✓						✓	✓	✓
1140185							✓	✓	✓						✓	✓	✓
1140186		✓						✓	✓	✓					✓	✓	✓
1140187			✓					✓	✓	✓					✓	✓	✓
1140188				✓				✓	✓	✓					✓	✓	✓
1140189					✓			✓	✓	✓					✓	✓	✓
1140190						✓		✓	✓	✓					✓	✓	✓
1140191							✓	✓	✓	✓					✓	✓	✓
1140192		✓						✓	✓	✓	✓				✓	✓	✓
1140193			✓					✓	✓	✓	✓				✓	✓	✓
1140194				✓				✓	✓	✓	✓				✓	✓	✓
1140195					✓			✓	✓	✓	✓				✓	✓	✓
1140196						✓		✓	✓	✓	✓				✓	✓	✓
1140197							✓	✓	✓	✓	✓				✓	✓	✓
1140198	✓	✓							✓	✓			✓	✓		✓	
1140199	✓		✓						✓	✓			✓	✓		✓	
1140200	✓			✓					✓	✓			✓	✓		✓	
1140201	✓				✓				✓	✓			✓	✓		✓	
1140202	✓					✓			✓	✓			✓	✓		✓	
1140203	✓						✓		✓	✓			✓	✓		✓	

2

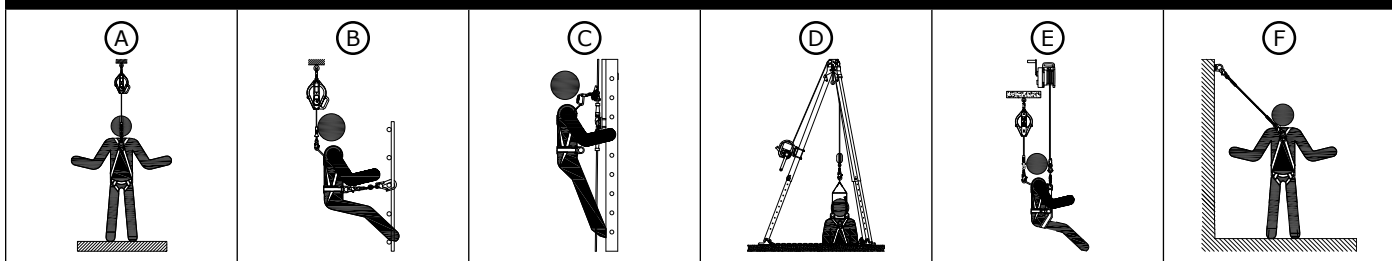

3

4

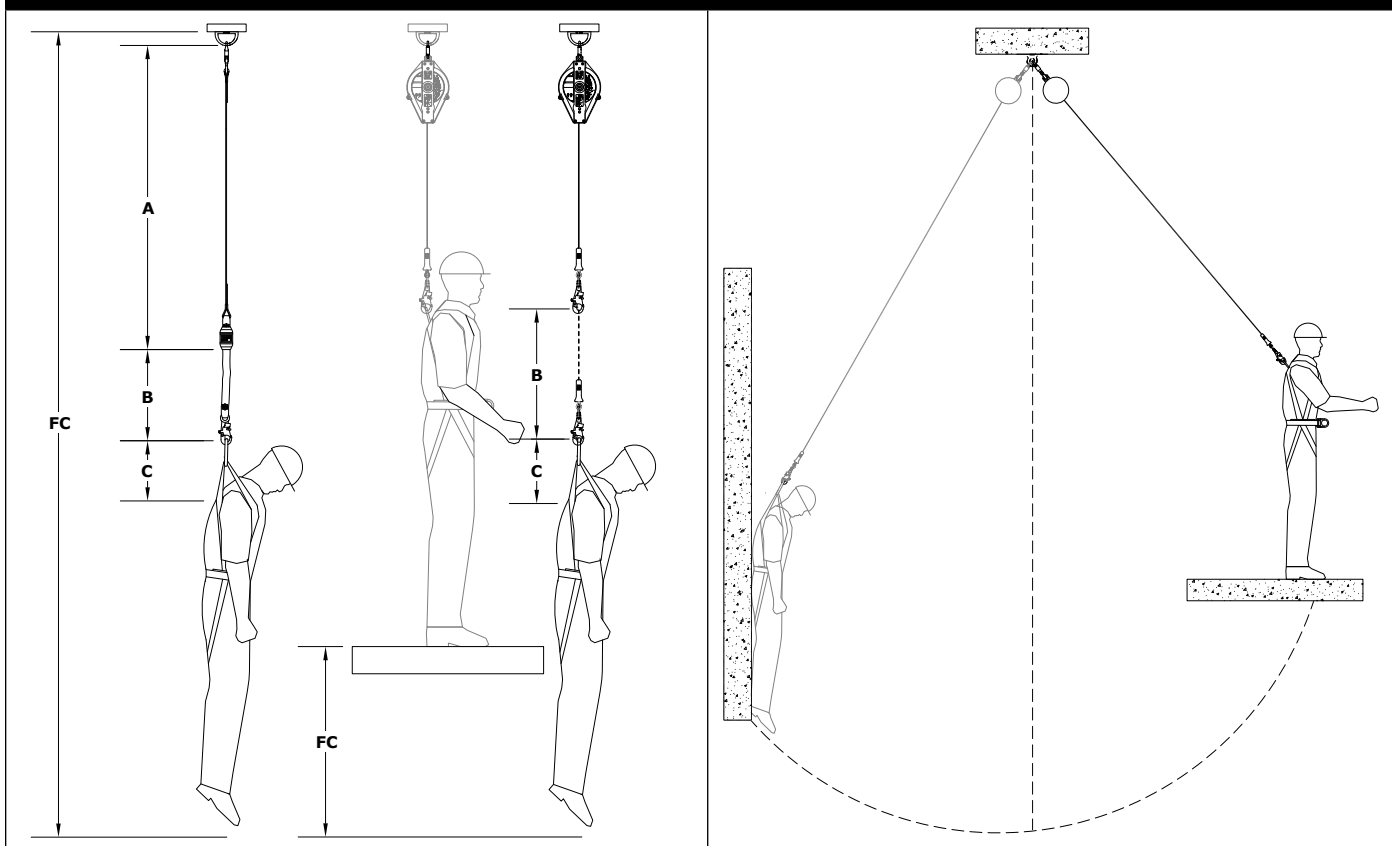

5

6

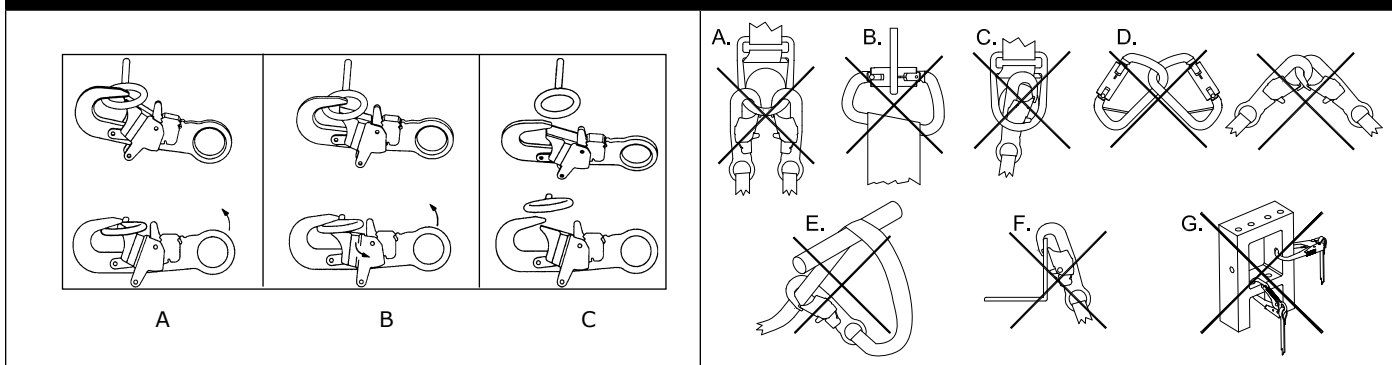

7

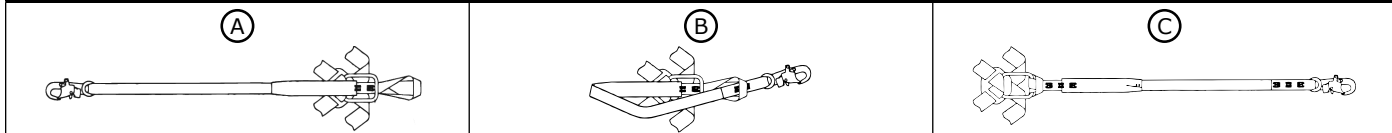

8

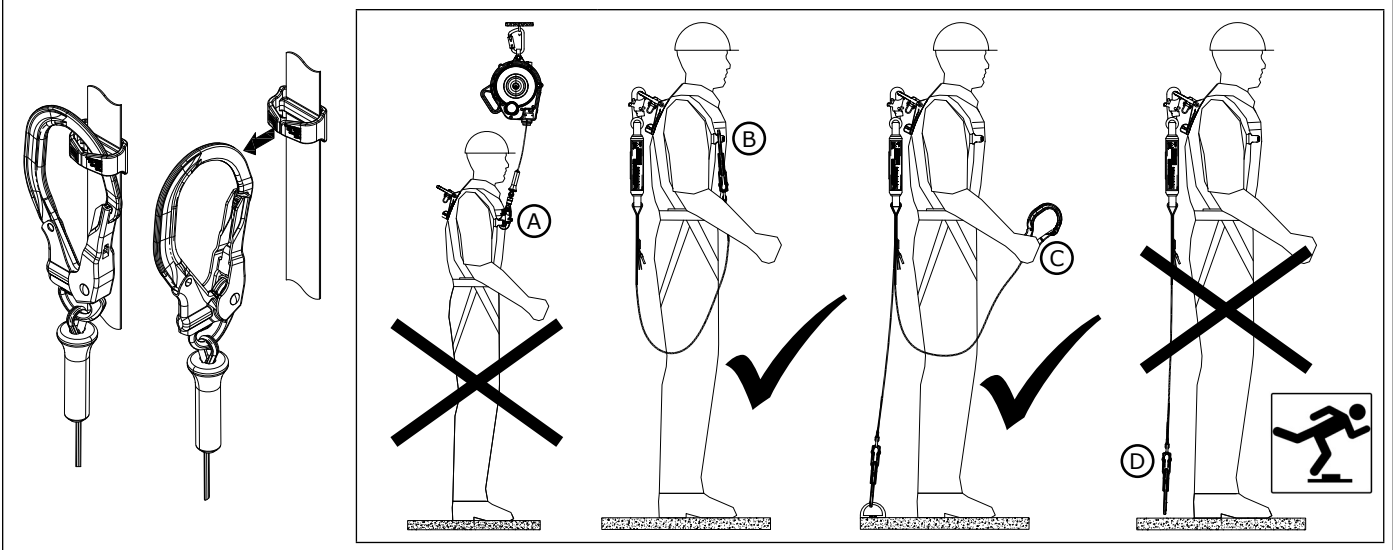

9

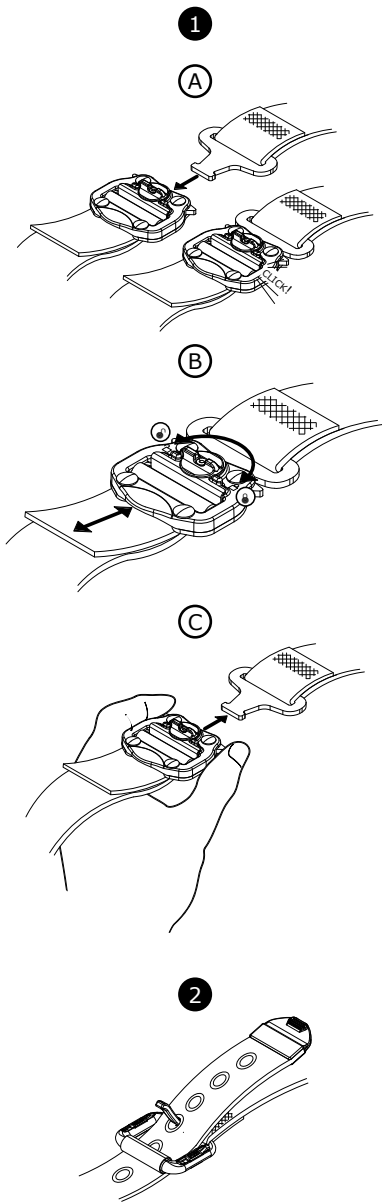

10

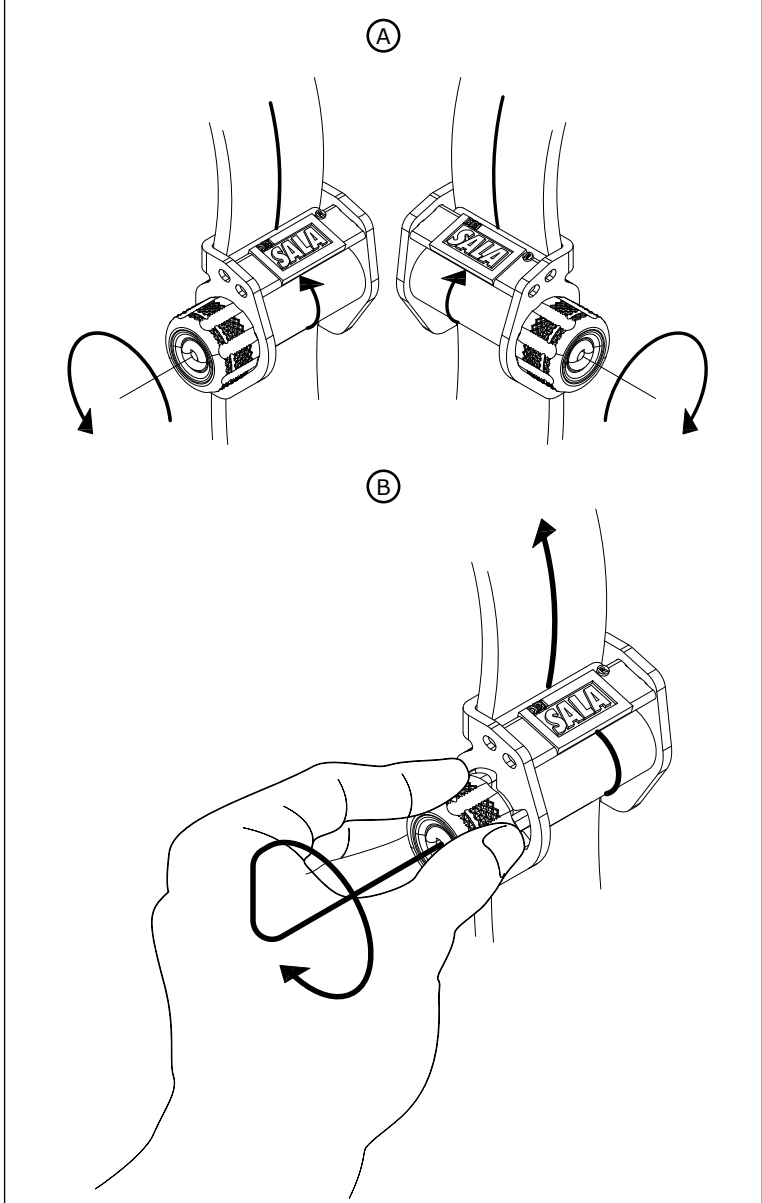

A

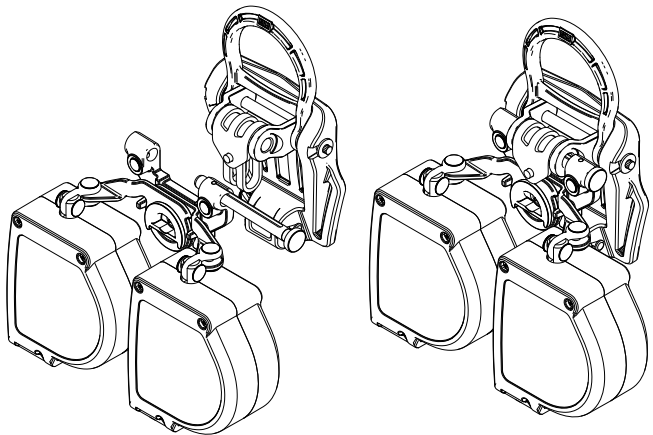

B

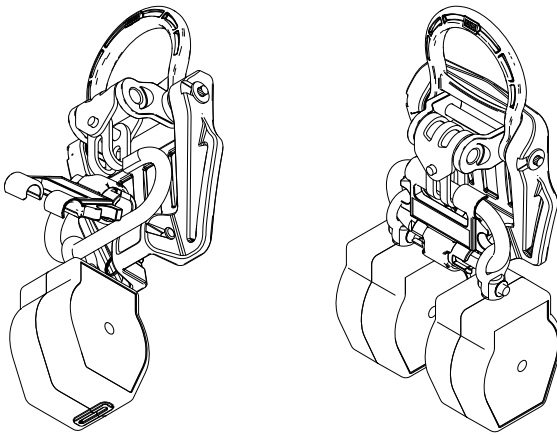

C

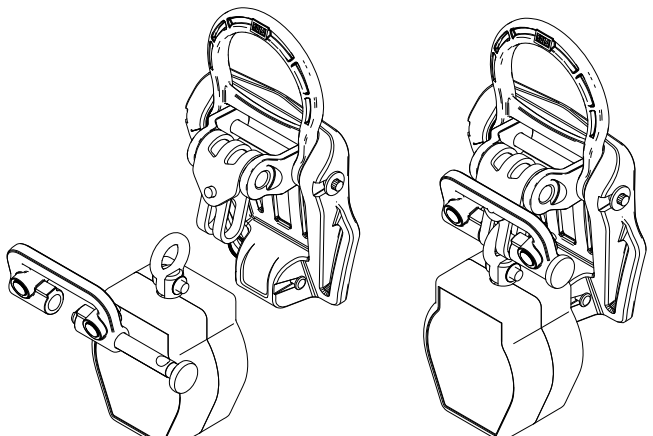

D

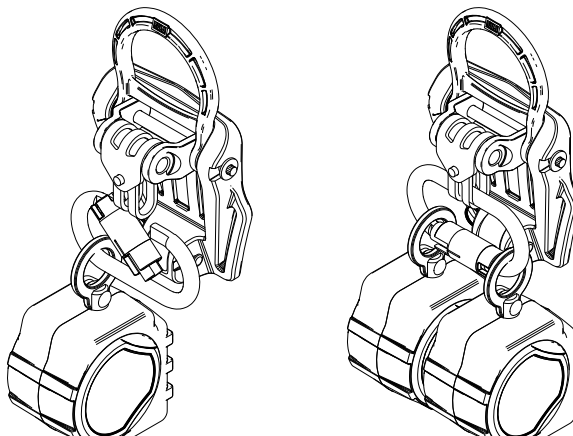

E

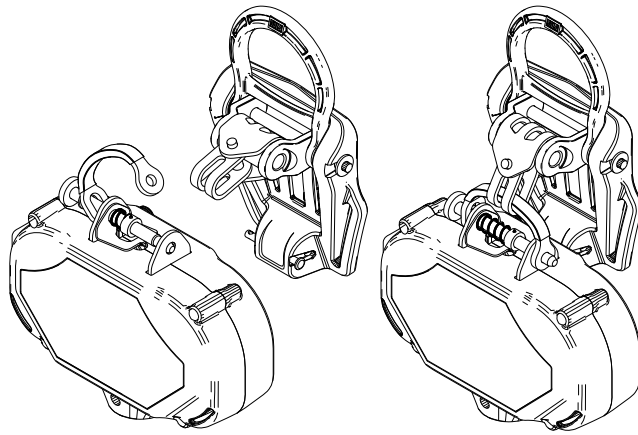

12

13

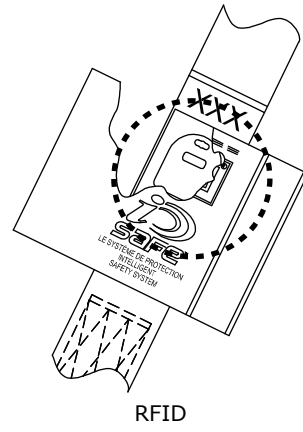

1



2



3

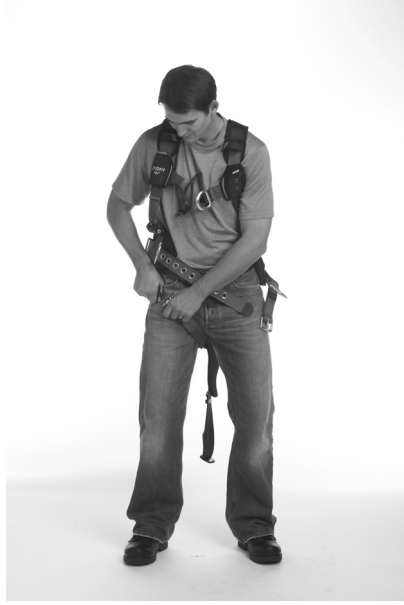

4



5



6







# SAFETY INFORMATION

**Please read, understand, and follow all safety information contained in these instructions prior to the use of this Full Body Harness. FAILURE TO DO SO COULD RESULT IN SERIOUS INJURY OR DEATH.**

**These instructions must be provided to the user of this equipment. Retain these instructions for future reference.**

## Intended Use:

This Full Body Harness is intended for use as part of a complete personal fall protection system.

Use in any other application including, but not limited to, material handling, recreational or sports related activities, or other activities not described in the User Instructions, is not approved by 3M and could result in serious injury or death.

This device is only to be used by trained users in workplace applications.

## **WARNING**

This Full Body Harness is part of a personal fall protection system. It is expected that all users be fully trained in the safe installation and operation of their personal fall protection system. **Misuse of this device could result in serious injury or death.** For proper selection, operation, installation, maintenance, and service, refer to these User Instructions and all manufacturer recommendations, see your supervisor, or contact 3M Technical Service.

- **To reduce the risks associated with working with a Full Body Harness which, if not avoided, could result in serious injury or death:**
  - Inspect the device before each use, at least annually, and after any fall event. Inspect in accordance with the User Instructions.
  - If inspection reveals an unsafe or defective condition, remove the device from service and destroy it.
  - Any device that has been subject to fall arrest or impact force must be immediately removed from service and destroyed.
  - Ensure the harness is worn correctly, appropriately sized, and properly adjusted.
  - Ensure all connecting subsystems (e.g. lanyards) are kept free from all hazards including, but not limited to, entanglement with other workers, yourself, moving machinery, or other surrounding objects.
  - Ensure that fall protection systems/subsystems assembled from components made by different manufacturers are compatible and meet the requirements of applicable standards, including the ANSI Z359 or other applicable fall protection codes, standards, or requirements. Always consult a Competent or Qualified Person before using these systems.
- **To reduce the risks associated with working at height which, if not avoided, could result in serious injury or death:**
  - Ensure your health and physical condition allow you to safely withstand all of the forces associated with working at height. Consult with your doctor if you have any questions regarding your ability to use this equipment.
  - Never exceed allowable capacity of your fall protection equipment.
  - Never exceed maximum free fall distance of your fall protection equipment.
  - Do not use any fall protection equipment that fails pre-use or other scheduled inspections, or if you have concerns about the use or suitability of the equipment for your application. Contact 3M Technical Services with any questions.
  - Some subsystem and component combinations may interfere with the operation of this equipment. Only use compatible connections. Consult 3M prior to using this equipment in combination with components or subsystems other than those described in the User Instructions.
  - Use extra precautions when working around moving machinery (e.g. top drive of oil rigs), electrical hazards, extreme temperatures, chemical hazards, explosive or toxic gases, sharp edges, or below overhead materials that could fall onto you or your fall protection equipment.
  - Use Arc Flash or Hot Works devices when working in high heat environments.
  - Avoid surfaces and objects that can damage the user or equipment.
  - Ensure there is adequate fall clearance when working at height.
  - Never modify or alter your fall protection equipment. Only 3M or parties authorized in writing by 3M may make repairs to the equipment.
  - Prior to use of fall protection equipment, ensure a rescue plan is in place which allows for prompt rescue if a fall event occurs.
  - If a fall event occurs, immediately seek medical attention for the worker who has fallen.
  - Do not use a body belt for fall arrest applications. Use only a Full Body Harness.
  - Minimize swing falls by working as directly below the anchorage point as possible.
  - If training with this device, a secondary fall protection system must be utilized in a manner that does not expose the trainee to an unintended fall hazard.
  - Always wear appropriate personal protective equipment when installing, using, or inspecting the device/system.

Before using this equipment, record the product identification information from the ID label in the "Inspection and Maintenance Log" at the back of this manual.

## DESCRIPTION

Figure 1 defines available ExoFit™ Nex™ Full Body Harness models. Harness models are available with various combinations of the following features:

	Figure 1 Reference:	Description:
<b>Sizes</b>	SM, MED, LG, XL, 2XL	Small, Medium, Large, Extra Large, Extra Extra Large
<b>Attachment Elements</b>	①	Suspension Seat
	②	EZ-Link
	③	Dorsal D-Ring
	④	Sternal D-Ring
	⑤	Shoulder D-Rings
	⑥	Hip D-Rings
<b>Buckles</b>	⑦	Duo-Lok Quick Connect
	⑧	Tongue Buckle
<b>Belt &amp; Pads</b>	⑨	Shoulder Pad
	⑩	Belt and Hip Pad
<b>Adjusters</b>	⑪	Revolver Torso Adjusters
<b>Other</b>	⑫	Lanyard Parking Attachments

## SPECIFICATIONS

Performance:	
Maximum Free Fall Distance	1.8 m (6 ft)
Maximum Arresting Force	6 kN (1,349 lbs)
Capacity	140 kg (310 lbs)

Materials:	
Webbing	Polyester - 27 kN (6,000 lbs) Tensile Strength Nylon - 31 kN (7,000 lbs) Tensile Strength
Pad Covers	Blend of Nylon and Polyester
Label Cover	Blend of Nylon and Polyester
Thread	Polyester Thread on Polyester Webbing Nylon Thread on Nylon Webbing
D-Rings	Aluminum Alloy - 22 kN (5,000 lbs) Tensile Strength
Tri-Lok Connectors	Aluminum Alloy, Stainless Steel, and Alloy Steel - 18 kN (4,000 lbs) Tensile Strength
Revolver Adjusters	Aluminum Alloy, Stainless Steel, Alloy Steel, and Nylon - 18 kN (4,000 lbs) Tensile Strength

## 1.0 APPLICATIONS

**1.1 PURPOSE:** Full Body Harnesses are to be used as components in Personal Fall Protection System designed to prevent a fall or safely arrest a fall (see Figure 2). Full Body Harnesses are used in the following applications:

(A)	<p><b>Fall Arrest:</b> Personal fall arrest systems typically include a Full Body Harness and a connecting subsystem (Energy Absorbing Lanyard, Self-Retracting Device, etc.). Maximum arresting force must not exceed 1,800 lbs (8 kN).</p> <p><i>Attachment Elements:</i> Dorsal (feet first with a 2 ft. maximum free fall when using a Self-Retracting Device or 6 ft. maximum free fall when using an Energy Absorbing Lanyard), Sternal (feet first with a 2 ft. maximum free fall), Frontal (feet first with a 2 ft. maximum free fall).</p>
(B)	<p><b>Work Positioning:</b> Work positioning systems typically include a Full Body Harness, positioning lanyard, and a back-up personal fall arrest system. For work positioning applications, connect the work positioning subsystem (example: lanyard, Y-lanyard, etc.) to the lower (hip level) side or belt mounted work positioning attachment anchorage elements (D-Rings). Never use these connection points for fall arrest.</p> <p><i>Attachment Elements:</i> Frontal, Hip.</p>
(C)	<p><b>Climbing:</b> The Full Body Harness is used as a component of a climbing system to prevent the user from falling when climbing a ladder or other climbing structure. Climbing systems typically include a Full Body Harness, vertical cable or rail attached to the structure, and climbing sleeve. For ladder climbing applications, harnesses equipped with a frontal D-Ring in the sternal location may be used for fall arrest on fixed ladder climbing systems.</p> <p><i>Attachment Elements:</i> Sternal</p>
(D)	<p><b>Rescue:</b> The Full Body Harness is used as a component of a rescue system. Rescue systems are configured depending on the type of rescue. For limited access (confined space) applications, harnesses equipped with D-Rings on the shoulders may be used for entry and egress into confined spaces where worker profile is an issue.</p> <p><i>Attachment Elements:</i> Dorsal, Sternal, Frontal, Shoulder</p>
(E)	<p><b>Controlled Descent:</b> For controlled descent applications, harnesses equipped with a single sternal level D-Ring, one or two frontal mounted D-Rings, or a pair of connectors originating below the waist (such as a seat sling) may be used for connection to a descent or evacuation system.</p> <p><i>Attachment Elements:</i> Dorsal Sternal, Frontal</p>
(F)	<p><b>Restraint:</b> The Full Body Harness is used as a component of a restraint system to prevent the user from reaching a fall hazard. Restraint systems typically include a Full Body Harness and a lanyard or restraint line.</p> <p><i>Attachment Elements:</i> Dorsal, Sternal, Frontal, Hip</p>
<input checked="" type="checkbox"/>	<p><b>Certain application and work conditions require the use of Full Body Harnesses with specific attributes:</b></p> <ul style="list-style-type: none"> <li>• Full body harnesses with Kevlar web should be used when working with tools, materials, or environments of high temperature (foundries, chemical manufacturing, steel fabrication, emergency rescue services, fire services, welders, oil industry, nuclear industry, explosives).</li> <li>• Harnesses with PVC coated hardware should be used when working in explosive or electrically conductive environments, or where surfaces must be protected from the hardware.</li> <li>• Harnesses with high visibility webbing should be used when increased visibility of the user is required.</li> </ul>

**1.2 STANDARDS:** Harnesses included in this manual conform to the standard(s) identified on the cover of this instruction.

**1.3 TRAINING:** It is the responsibility of the user and the purchaser of this equipment to assure that they are familiar with these instructions, trained in the correct care and use of, and are aware of the operating characteristics, application limits, and the consequences of improper use of this equipment.

**1.4 LIMITATIONS:** Always consider the following application limitations before using this equipment:

- **CAPACITY:** The Full Body Harness is designed for use by persons with a combined weight (clothing, tools, etc.) ranging from 130 lbs (59 kg) to 310 lbs (140 kg)<sup>1</sup>. Make sure all of the components in your system are rated to a capacity appropriate to your application.
- **FREE FALL:** Personal fall arrest systems used with this equipment must be rigged to limit the free fall to 6 feet (1.8 m)<sup>2</sup>. Restraint systems must be rigged so that no vertical free fall is possible. Work positioning systems must be rigged so that free fall is limited to 2 feet (.6 m) or less. Personnel riding systems must be rigged so that no vertical free fall is possible. Climbing systems must be rigged so that free fall is limited to 18 in. (.46 m) or less. Rescue systems must be rigged so that no vertical free fall is possible. See subsystem manufacturer's instructions for more information.
- **FALL CLEARANCE:** Figure 3 illustrates the components of a Fall Arrest. There must be sufficient Fall Clearance (FC) to arrest a fall before the user strikes the ground or other obstruction. Clearance is affected by a number of factors including: (A) Lanyard Length, (B) Lanyard Deceleration Distance or SRL Maximum Arrest Distance, (C) Harness Stretch and D-Ring/Connector Length and Settling (typically a Safety Factor of 1.5 ft). Refer to the instructions included with your Lanyard or Self-Retracting Device for specifics regarding Fall Clearance calculation.
- **SWING FALLS:** Swing Falls occur when the anchorage point is not directly above the point where a fall occurs (see Figure 4). The force of striking an object in a swing fall may cause serious injury or death. Minimize swing falls by working as directly below the anchorage point as possible. Do not permit a swing fall if injury could occur. Swing falls will significantly increase the clearance required when a Self-Retracting Device or other variable length connecting subsystem is used.
- **EXTENDED SUSPENSION:** A Full Body Harness is not intended for use in extended suspension applications. If the user is going to be suspended for an extended length of time it is recommended that some form of seat support be used. 3M recommends a seat board, suspension work seat, seat sling, or a boatswain chair. Contact 3M for more information on these items.
- **ENVIRONMENTAL HAZARDS:** Use of this equipment in areas with environmental hazards may require additional precautions to prevent injury to the user or damage to the equipment. Hazards may include, but are not limited to; heat, chemicals, corrosive environments, high voltage power lines, gases, moving machinery, and sharp edges. Although PVC coated and zinc plated hardware exhibit excellent corrosion resistance in chemical, acidic, alkaline, and atmospheric conditions, frequent inspections may be required. Consult with 3M if you question the use of this equipment in hazardous environments.
- **HARNESSES FOR HIGH TEMPERATURE ENVIRONMENTS:** Harnesses with Kevlar webbing are designed for use in high temperature environments, with limitations: Kevlar webbing begins to char at 800° to 900° Fahrenheit. Kevlar webbing can withstand limited contact exposure to temperatures up to 1,000° F. Polyester webbing loses strength at 300° to 400° F. PVC coating on hardware has a melting point of approximately 350° F. When working with tools, materials, or in high temperature environments, ensure that associated fall protection equipment can withstand high temperatures, or provide protection for those items.

<sup>1</sup> **Capacity:** 310 lbs (140 kg) is the maximum capacity allowed by ANSI/ASSE Z359.11. 3M harnesses are factory tested to a maximum capacity of 420 lbs (191 kg).

<sup>2</sup> **Fall Arrest Free Falls:** Free falls greater than 6 ft. (1.8 m) may be permitted when users are secured to the anchorage with a connecting subsystem which limits maximum arresting force to 1,800 lbs (8 kN) and is authorized for such use (i.e., DBI-SALA Force 2™ Lanyards).

## 2.0 SYSTEM USE

- 2.1 RESCUE PLAN:** When using this equipment and connecting subsystem(s), the employer must have a rescue plan and the means at hand to implement and communicate that plan to users<sup>3</sup>, authorized persons<sup>4</sup>, and rescuers<sup>5</sup>.
- 2.2 INSPECTION FREQUENCY:** The Full Body Harness shall be inspected by the user before each use and by a competent person<sup>6</sup> other than the user at intervals of no more than one year<sup>7</sup>. Inspection procedures are described in the "Inspection and Maintenance Log". Results of each Competent Person inspection should be recorded on copies of the "Inspection and Maintenance Log" or tracked with a Radio Frequency Identification (RFID) system (see "Inspection").
- 2.3 COMPATIBILITY OF COMPONENTS:** 3M equipment is designed for use with 3M approved components and subsystems only. Substitutions or replacements made with non-approved components or subsystems may jeopardize compatibility of equipment and may effect the safety and reliability of the complete system.

- 2.4 COMPATIBILITY OF CONNECTORS:** Connectors are compatible with connecting elements when they have been designed to work together in such a way that their sizes and shapes do not cause their gate mechanisms to inadvertently open regardless of how they become oriented. Contact Capital Safety if you have any questions about compatibility.

Connectors (hooks, carabiners, and D-Rings) must be capable of supporting at least 5,000 lbs. (22.2 kN). Connectors must be compatible with the anchorage or other system components. Do not use equipment that is not compatible. Non-compatible connectors may unintentionally disengage (See Figure 5). Connectors must be compatible in size, shape, and strength. If the connecting element to which a snap hook (shown) or carabiner attaches is undersized or irregular in shape, a situation could occur where the connecting element applies a force to the gate of the snap hook or carabiner. This force may cause the gate (of either a self-locking or a non-locking snap hook) to open, allowing the snap hook or carabiner to disengage from the connecting point. Self-locking snap hooks and carabiners are required.

- 2.5 MAKING CONNECTIONS:** Use only self-locking snap hooks and carabiners with this equipment. Use only connectors that are suitable for each application. Ensure all connections are compatible in size, shape and strength. Do not use equipment that is not compatible. Ensure all connectors are fully closed and locked.

3M connectors (snap hooks and carabiners) are designed to be used only as specified in each product's user's instructions. See Figure 6 for inappropriate connections. 3M snap hooks and carabiners should not be connected:

- A. To a D-Ring to which another connector is attached.
  - B. In a manner that would result in a load on the gate.
  - C. In a false engagement, where features that protrude from the snap hook or carabiner catch on the anchor, and without visual confirmation seems to be fully engaged to the anchor point.
  - D. To each other.
  - E. Directly to webbing or rope lanyard or tie-back (unless the manufacturer's instructions for both the lanyard and connector specifically allows such a connection).
  - F. To any object which is shaped or dimensioned such that the snap hook or carabiner will not close and lock, or that roll-out could occur.
  - G. In a manner that does not allow the connector to align properly while under load.
- 2.6 CONNECTING SUBSYSTEMS:** Connecting subsystems (self-retracting lifeline, lanyard, rope grab and lifeline, cable sleeve, etc.) must be suitable for your application (See section 1.1). See the subsystem manufacturer's instructions for additional information. Some harness models have web loop connection points. Do not use snap hooks to connect to web loops. Use a self-locking carabiner to connect to a web loop. Ensure the carabiner cannot cross-gate load (load against the gate rather than along the major axis of the carabiner). Some lanyards are designed to choke onto a web loop to provide a compatible connection. Lanyards may be sewn directly to the web loop forming a permanent connection. Do not make multiple connections onto one web loop, unless choking two lanyards onto a properly sized web loop. To choke the lanyard on a web loop (Figure 7): A) Insert the lanyard web loop through the web loop or D-Ring on the harness. B) Insert the appropriate end of the lanyard through the lanyard web loop. C) Pull the lanyard through the connecting web loop to secure.
- 2.7 LANYARD PARKING ATTACHMENT:** Figure 8 illustrates Lanyard Parking. The Lanyard Parking Attachment is for attaching the free end of a Lanyard or harness mounted Self-Retracting Device when not connected to an Anchorage Connection Point for purposes of fall protection. Lanyard Parking Attachments must never be used as a Fall Protection Attachment Element on the Harness for connecting a Lanyard or Self-Retracting Device (A).

When not connected to an Anchorage Connection Point, an unconnected Lanyard Leg must be properly parked on the harness (B) or secured in the user's hand as in 100% Tie-Off applications (C). Free hanging Lanyard Legs (D) can trip the user or catch on surrounding objects resulting in a fall.

<sup>3</sup> **User:** A person who performs activities at heights while protected by a personal fall protection system.

<sup>4</sup> **Authorized Person:** A person assigned by the employer to perform duties at a location where the person will be exposed to a fall hazard.

<sup>5</sup> **Rescuer:** Person or persons other than the rescue subject acting to perform an assisted rescue by operation of a rescue system.

<sup>6</sup> **Competent Person:** One who is capable of identifying existing and predictable hazards in the surroundings or working conditions which are unsanitary, hazardous, or dangerous to employees, and who has authorization to take prompt corrective measures to eliminate them.

<sup>7</sup> **Inspection Frequency:** Extreme working conditions (harsh environments, prolonged use, etc.) may require increasing the frequency of competent person inspections.

### 3.0 HARNESS USE



**3.1 BEFORE EACH USE** of this equipment inspect it according to the "Inspection and Maintenance Log" (Table 1).

**3.2 PLAN** your system before use. Consider all factors that will affect your safety during use of this equipment. The following list gives important points to consider when planning your system:

- **Anchorage:** Select an anchorage capable of sustaining the Static Load requirements of the intended fall protection application (see Section 1.1). The anchorage location should address Free Fall, Fall Clearance, Swing Fall, and Environmental limitations described in Section 1.4.
- **Sharp Edges:** Avoid working where system components may be in contact with, or abrade against, unprotected sharp edges.
- **After A Fall:** Components which have been subjected to the forces of arresting a fall must be removed from service and destroyed.
- **Rescue:** The employer must have a rescue plan when using this equipment. The employer must have the ability to perform a rescue quickly and safely.
- **Rescue Harness:** Rescue Harnesses are intended to be worn during normal work activities. Before using rescue attachment elements for the first time, the user should carry out a suspension test in safe conditions to ensure the harness is sized and fitted for optimal comfort during suspension.

**3.3 BUCKLES:** ExoFit Nex Full Body Harnesses are equipped with Duo-Lok™ Quick Connect Buckles for fastening and adjusting Leg Straps and Chest Straps. Harness Body Belts have a Tongue Buckle. See Figure 1 for the buckle types on your ExoFit Nex Harness. Figure 9 illustrates operation of each of the following buckles:

**1. Duo-Lok™ Quick Connect Buckles:**

- A. To fasten the Duo-Lok Quick Connect Buckle, insert the Tab into the Receptor until a click is heard.
- B. To adjust the attached Web Strap: Rotate the Webbing Lock to the Unlocked position . Pull the Web Strap forward or backward through the Buckle Slot to tighten or loosen. After adjustment, rotate the Webbing Lock to the Locked position .

*The Webbing Lock does not lock or unlock engagement or disengagement of the buckle end. It only prevents or allows passage of the excess Web Strap through the Buckle Slot.*

- C. To release the Duo-Lok Quick Connect Buckle: Squeeze the Lock Levers on each side of the Receptor. Pull the Tab out of the Receptor.

**2. Tongue Buckles:** Fasten and adjust Tongue Buckles by passing the Tongue through the Buckle Frame and inserting the Prong through the desired Grommet in the Tongue.

**3.4 ADJUSTMENTS:** ExoFit Nex Harnesses are equipped with a pair of Revolver™ Torso Adjusters for adjusting the Shoulder Straps. Figure 10 illustrates adjustment of the Revolver Torso Adjusters:

**1. Revolver™ Torso Adjusters:** To adjust the Shoulder Straps with the Revolver Torso Adjusters:

- A. Rotate the Revolver Ratchet Knobs as illustrated in Figure 10 to tighten the Shoulder Straps.
- B. Pull out and rotate the Revolver Ratchet Knobs as illustrated in Figure 10 to loosen the Shoulder Straps.

**3.5 EASY-LINK™ ATTACHMENTS:** ExoFit Nex Full Body Harnesses are equipped with a patented Easy-Link™ System that integrates the Dorsal D-Ring with attachment elements for Harness-Mounted Self-Retracting Devices (SRDs). Figure 11 illustrates attachment of the following 3M and Protecta Self-Retracting Devices: (A) 3M Nano-Lok™ Edge SRDs, (B) 3M Twin Nano-Lok™ SRDs, (C) 3M Single Nano-Lok™ SRDs, (D) Protecta Twin Rebel™ SRDs, (E) 3M Twin Talon™ SRD. Other manufacturers' SRDs can also be mounted on the ExoFit Nex Harness in similar fashion. See the SRD manufacturer's instructions for requirements and installation instructions specific to the SRD.

*Contact 3M with any questions or concerns regarding compatibility of your SRD with the Easy-Link System.*

**3.6 DONNING AND FITTING THE EXOFIT NEX FULL BODY HARNESS:** Figure 14 illustrates donning and fitting of the ExoFit Nex Full Body Harness. Prior to each use, inspect the harness per the checklist on the "Inspection and Maintenance Log (Table 1)". To don and fit the harness:

*Procedures for buckling and adjusting the straps on you ExoFit Nex Harness will vary with the harness model. See Sections 3.3 thru 3.4 and Figures 9 thru 10 for details.*

1. Lift up and hold the harness by the back Dorsal D-Ring on the Easy-Link System. Ensure the straps are not twisted.
2. Grasp the Shoulder Straps and slip the harness onto one arm. The Dorsal D-Ring will be located on your back side. Ensure that the straps are not tangled and hang freely. Slip your free arm into the harness and position the Shoulder Straps on top of your shoulders. The Chest Strap and Chest Buckle will be positioned on the front side when worn properly.
3. Reach between your legs and grasp the Leg Strap on your right side. Bring the strap up between your legs; buckle to the mating receptor on you right hip, and adjust the Leg Strap for a snug comfortable fit (see Section 3.3 for buckle operation). When properly adjusted, tuck the loose end of the Leg Strap under the Strap Keeper.

Repeat this process to buckle and adjust the left Leg Strap.

4. Adjust and buckle the Tongue Buckle Waist Belt (see Section 3.3 for Tongue Buckle operation).
5. Buckle and adjust the Chest Strap (see Section 3.3 for buckle operation). The Chest Strap should be 6 in. (15 cm) down from the top of your shoulders. When properly adjusted, tuck the loose end of the Chest Strap under the Strap Keeper.
6. Adjust the Shoulder Straps for a Snug Fit with the Revolver Torso Adjusters (see Section 3.4 for Torso Adjuster operation). Left and right sides of Shoulder Straps should be adjusted to the same length and the Chest Strap should be centered on your lower chest, 6 in. (15 cm) down from the shoulders. The back Dorsal D-Ring should be centered between your Shoulder Blades. The front Sternal D-Ring, if present, should be located laterally within 2 in. (51 mm) of the vertical centerline of the harness (see Section 3.6 for Store-Away D-Ring adjustment).

**3.7 USE OF FALL ARREST D-RING OR ATTACHMENT ELEMENT:** For Fall Arrest applications connect to the Dorsal D-ring or attachment element on your back, between your shoulder blades. Side D-rings, if present, are for Positioning or Restraint applications only. Shoulder D-rings are for Rescue or Retrieval applications only. The front Sternal D-ring is for Ladder Climbing or Positioning. D-rings on a Suspension Seat are for Suspension or Positioning applications only. (See Section 1.1.).

**3.8 MAKING CONNECTIONS:** When using a hook to connect to an anchorage or when coupling components of the system together, ensure roll-out cannot occur. Roll-out occurs when interference between the hook and mating connector causes the hook gate to unintentionally open and release. Self-locking snap hooks and carabiners should be used to reduce the possibility of roll-out. Do not use hooks or connectors that will not completely close over the attachment object. See subsystem manufacturer's instructions for more information on making connections.

**3.9 CONNECTING SYSTEM COMPONENTS:** After fitting the ExoFit Nex Harness the user may then connect to other system components. Follow the guidelines in Section 2 and the manufacturer's instructions included with the component.

**3.10 SUSPENSION TRAUMA STRAP:** The ExoFit Nex Full Body Harness is equipped with Suspension Trauma Straps (Figure 14) to help prolong allowable suspension time in the event of a fall from height. They should only be used in situations where a fall has occurred or for training. To use the Suspension Trauma Straps:

1. Unzip the Trauma Strap Pouch on each hip of the harness and deploy the Suspension Straps (Figure 12A).
2. Raise the ends of the straps to access the hook and loops. Insert the hook into the loop that provides the desired strap length.
3. Lower the Suspension Strap and step onto the strap to alleviate pressure of the harness leg straps on the legs (Figure 12B). Adjust the hook/loop combination for optimal comfort.

<input checked="" type="checkbox"/> <i>Maintain an upright position following suspension. Do not lay down. Seek medical attention following a suspension.</i>
---

## 4.0 INSPECTION

- 4.1 **RFID TAG:** The Radio Frequency Identification (RFID) tag on the ExoFit Nex Harness (see Figure 13) can be used in conjunction with a handheld reading device and the web based portal to simplify inspection and inventory control and provide records for your fall protection equipment.
- 4.2 **INSPECTION FREQUENCY:** The ExoFit Nex Full Body Harness must be inspected at the intervals defined in Section 2.2. Inspection procedures are described on the "Inspection and Maintenance Log" (Table 1).
- 4.3 **DEFECTS:** If inspection reveals a defective condition, remove unit from service immediately and destroy.
- 4.4 **PRODUCT LIFE:** The functional life of ExoFit Nex Harnesses is determined by work conditions and maintenance. As long as the product passes inspection criteria, it may remain in service.

## 5.0 MAINTENANCE, SERVICING, STORAGE

### 5.1 CLEANING INSTRUCTIONS: Clean the ExoFit Nex Full Body Harness as follows:

1. Spot clean the harness with water and a mild soap solution.

Use a bleach-free detergent when washing the harness and pads. Fabric softener or dryer sheets **SHOULD NOT** be used when laundering and drying the harness and pads.

2. Water temperature for wash and rinse must not exceed 160° F (70° C).
3. The harness and pads may be air dried or tumble dried on low heat not exceeding 200° F (90° C).

More information on cleaning is available from 3M. If you have questions concerning the condition of your harness, or have any doubt about putting it into service, contact 3M.

- 5.2 **AUTHORIZED SERVICE:** Additional maintenance and servicing procedures must be completed by a factory authorized service center. Authorization must be in writing. Do not attempt to disassemble the unit.
- 5.3 **STORAGE AND TRANSPORT:** Store and transport the ExoFit Nex Full Body Harness in a cool, dry, clean environment out of direct sunlight. Avoid areas where chemical vapors may exist. Thoroughly inspect the harness after extended storage.

### 6.0 LABELING:

Figure 15 illustrates product labels and their location on the ExoFit Nex Full Body Harness. All labeling must be present and fully legible.

**Table 1 – Inspection and Maintenance Log**

<b>Serial Number(s):</b>	<b>Date Purchased:</b>
<b>Model Number:</b>	<b>Date of First Use:</b>

**Inspection Date:** \_\_\_\_\_ **Inspected By:** \_\_\_\_\_

<b>Component:</b>	<b>Inspection: (See Section 2.2 for Inspection Frequency)</b>	<b>User</b>	<b>Competent Person</b>
Harness Hardware (Diagram 1)	Inspect harness hardware including buckles (1), adjusters (2), D-rings (3), Easy-Link (4), loop keepers (5), lanyard parking (6), etc. These items must not be damaged, broken, or distorted, and must be free of sharp edges, burrs, cracks, worn parts, or corrosion. PVC coated hardware must be free of cuts, rips, tears, holes, etc. in the coating to ensure non-conductivity. Ensure buckles and adjusters work smoothly.	<input type="checkbox"/>	<input type="checkbox"/>
Webbing & Stitching (Diagram 2)	Inspect webbing; material must be free of frayed, cut, or broken fibers. Check for tears, abrasions, mold, burns, or discoloration. Inspect stitching; Check for pulled or cut stitches. Broken stitches may be an indication that the harness has been impact loaded and must be removed from service.	<input type="checkbox"/>	<input type="checkbox"/>
Stitched Impact Indicators (Diagram 3)	The Stitched Impact Indicators are sections of webbing lapped back on themselves and secured with a specific stitch pattern. The stitch pattern is designed to release when the harness arrests a fall or is exposed to equivalent force. <b>If an Impact Indicator has been activated (indicated), the harness must be removed from service and destroyed.</b>	<input type="checkbox"/>	<input type="checkbox"/>
Labels	All labels should be present and fully legible. See Figure 17.	<input type="checkbox"/>	<input type="checkbox"/>
System & Subsystem Components	Inspect each system component or subsystem according to the manufacturer's instructions.	<input type="checkbox"/>	<input type="checkbox"/>

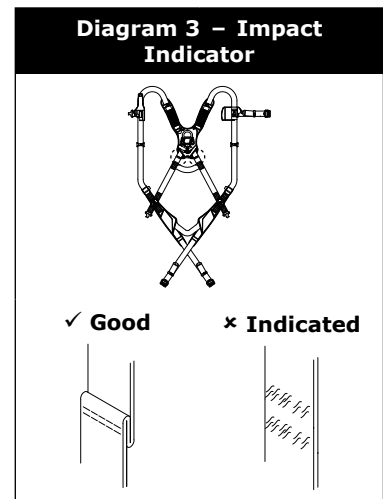
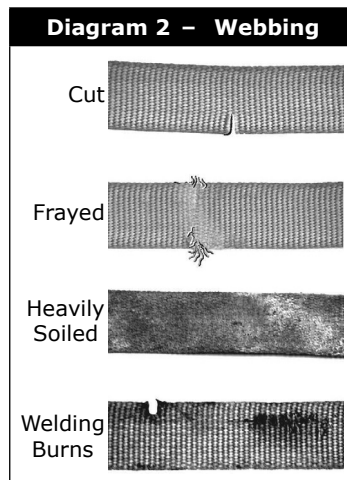
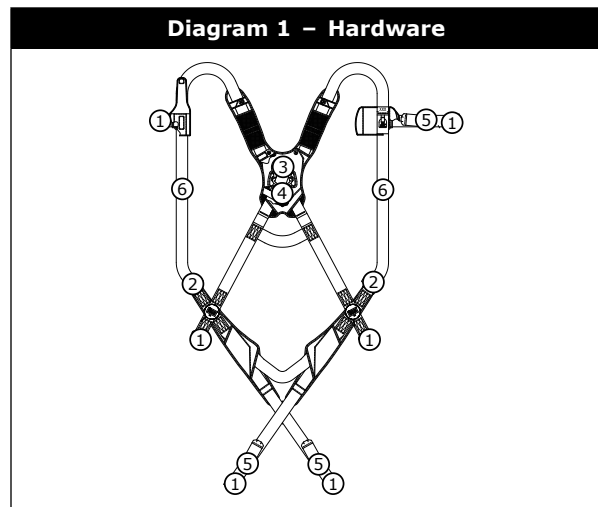

<b>Corrective Action/Maintenance:</b>	Approved By:
	Date:
<b>Corrective Action/Maintenance:</b>	Approved By:
	Date:
<b>Corrective Action/Maintenance:</b>	Approved By:
	Date:
<b>Corrective Action/Maintenance:</b>	Approved By:
	Date:
<b>Corrective Action/Maintenance:</b>	Approved By:
	Date:
<b>Corrective Action/Maintenance:</b>	Approved By:
	Date:
<b>Corrective Action/Maintenance:</b>	Approved By:
	Date:
<b>Corrective Action/Maintenance:</b>	Approved By:
	Date:



① **NOTE:** *These are general requirements and information provided by ANSI/ASSE Z359, the Manufacturer of this equipment may impose more stringent restrictions on the use of the products they manufacture, see the Manufacturer's instructions.*

1. It is essential that the users of this type of equipment receive proper training and instruction, including detailed procedures for the safe use of such equipment in their work application. ANSI/ASSE Z359.2, Minimum Requirements for a Comprehensive Managed Fall Protection Program, establishes guidelines and requirements for an employer's managed fall protection program, including policies, duties and training; fall protection procedures; eliminating and controlling fall hazards; rescue procedures; incident investigations; and evaluating program effectiveness.
2. Correct fit of a Full Body Harness is essential to proper performance. Users must be trained to select the size and maintain the fit of their Full Body Harness.
3. Users must follow manufacturer's instructions for proper fit and sizing, paying particular attention to ensure that buckles are connected and aligned correctly, leg straps and shoulder straps are kept snug at all times, chest straps are located in the middle chest area and leg straps are positioned and snug to avoid contact with the genitalia should a fall occur.
4. Full Body Harnesses which meet ANSI/ASSE Z359.11 are intended to be used with other components of a Personal fall Arrest system that limit maximum arrest forces to 1800 pounds (8 kn) or less.
5. Suspension intolerance, also called suspension trauma or orthostatic intolerance, is a serious condition that can be controlled with good harness design, prompt rescue and post fall suspension relief devices. A conscious user may deploy a suspension relief device allowing the user to remove tension from around the legs, freeing blood flow, which can delay the onset of suspension intolerance. An attachment element extender is not intended to be attached directly to an anchorage or anchorage connector for fall arrest. An energy absorber must be used to limit maximum arrest forces to 1800 pounds (8 kn). the length of the attachment element extender may affect free fall distances and free fall clearance calculations.
6. Full Body Harness (FBH) Stretch, the amount the FBH component of a personal fall arrest system will stretch and deform during a fall, can contribute to the overall elongation of the system in stopping a fall. it is important to include the increase in fall distance created by FBH Stretch, as well as the FBH connector length, the settling of the user's body in the FBH and all other contributing factors when calculating total clearance required for a particular fall arrest system.
7. When not in use, unused lanyard legs that are still attached to a Full Body Harness D-Ring should not be attached to a work positioning element or any other structural element on the Full Body Harness unless deemed acceptable by the competent person and manufacturer of the lanyard. this is especially important when using some types of "Y" style lanyards, as some load may be transmitted to the user through the unused lanyard leg if it is not able to release from the harness. the lanyard parking attachment is generally located in the sternal area to help reduce tripping and entanglement hazards.
8. Loose ends of straps can get caught in machinery or cause accidental disengagement of an adjuster. All Full Body Harnesses shall include keepers or other components which serve to control the loose ends of straps.
9. Due to the nature of soft loop connections, it is recommended that soft loop attachments only be used to connect with other soft loops or carabiners. Snaphooks should not be used unless approved for the application by the manufacturer.

**Sections 10-16 provide additional information concerning the location and use of various attachments that may be provided on this FBH.**

- 10. Dorsal** – the dorsal attachment element shall be used as the primary fall arrest attachment, unless the application allows the use of an alternate attachment. the dorsal attachment may also be used for travel restraint or rescue. When supported by the dorsal attachment during a fall, the design of the Full Body Harness shall direct load through the shoulder straps supporting the user, and around the thighs. Supporting the user, post fall, by the dorsal attachment will result in an upright body position with a slight lean to the front with some slight pressure to the lower chest. considerations should be made when choosing a sliding versus fixed dorsal attachment element. Sliding dorsal attachments are generally easier to adjust to different user sizes, and allow a more vertical rest position post fall, but can increase FBH Stretch.
- 11. Sternal** – the sternal attachment may be used as an alternative fall arrest attachment in applications where the dorsal attachment is determined to be inappropriate by a competent person, and where there is no chance to fall in a direction other than feet first. Accepted practical uses for a sternal attachment include, but are not limited to, ladder climbing with a guided type fall arrester, ladder climbing with an overhead self-retracting lifeline for fall arrest, work positioning and rope access. the sternal attachment may also be used for travel restraint or rescue.

When supported by the sternal attachment during a fall, the design of the Full Body Harness shall direct load through the shoulder straps supporting the user, and around the thighs. Supporting the user, post fall, by the sternal attachment will result in roughly a sitting or cradled body position with weight concentrated on the thighs, buttocks and lower back. Supporting the user during work positioning by this sternal attachment will result in an approximate upright body position.

if the sternal attachment is used for fall arrest, the competent person evaluating the application should take measures to ensure that a fall can only occur feet first. This may include limiting the allowable free fall distance. it may be possible for a sternal attachment incorporated into an adjustable style chest strap to cause the chest strap to slide up and possibly choke the user during a fall, extraction, suspension, etc. The competent person should consider Full Body Harness models with a fixed sternal attachment for these applications.

- 12. Frontal** – the frontal attachment serves as a ladder climbing connection for guided type fall arresters where there is no chance to fall in a direction other than feet first, or may be used for work positioning. Supporting the user, post fall or during work positioning, by the frontal attachment will result in a sitting body position, with the upper torso upright, with weight concentrated on the thighs and buttocks. When supported by the frontal attachment the design of the Full Body Harness shall direct load directly around the thighs and under the buttocks by means of the sub-pelvic strap.
- if the frontal attachment is used for fall arrest, the competent person evaluating the application should take measures to ensure that a fall can only occur feet first. This may include limiting the allowable free fall distance.
- 13. Shoulder** – the shoulder attachment elements shall be used as a pair, and are an acceptable attachment for rescue and entry/retrieval. the shoulder attachment elements shall not be used for fall arrest. it is recommended that the shoulder attachment elements be used in conjunction with a yoke which incorporates a spreader element to keep the Full Body Harness shoulder straps separate.
- 14. Waist, Rear** – the waist, rear attachment shall be used solely for travel restraint. the waist, rear attachment element shall not be used for fall arrest. Under no circumstances is it acceptable to use the waist, rear attachment for purposes other than travel restraint. the waist, rear attachment shall only be subjected to minimal loading through the waist of the user, and shall never be used to support the full weight of the user.
- 15. Hip** – the hip attachment elements shall be used as a pair, and shall be used solely for work positioning. the hip attachment elements shall not be used for fall arrest. Hip attachments are often used for work positioning by arborists, utility workers climbing poles and construction workers tying rebar and climbing on form walls. Users are cautioned against using the hip attachment elements (or any other rigid point on the Full Body Harness) to store the unused end of a fall arrest lanyard, as this may cause a tripping hazard, or, in the case multiple leg lanyards, could cause adverse loading to the Full Body Harness and the wearer through the unused portion of the lanyard.
- 16. Suspension Seat** – the suspension seat attachment elements shall be used as a pair, and shall be used solely for work positioning. the suspension seat attachment elements shall not be used for fall arrest. Suspension seat attachments are often used for prolonged work activities where the user is suspended, allowing the user to sit on the suspension seat formed between the two attachment elements. An example of this use would be window washers on large buildings.

### ***User Inspection, Maintenance, and Storage of Equipment***

Users of personal fall arrest systems shall, at a minimum, comply with all manufacturer instructions regarding the inspection, maintenance and storage of the equipment. the user's organization shall retain the manufacturer's instructions and make them readily available to all users. See ANSI/ASSE Z359.2, Minimum Requirements for a Comprehensive Managed Fall Protection Program, regarding user inspection, maintenance and storage of equipment.

1. In addition to the inspection requirements set forth in the manufacturer's instructions, the equipment shall be inspected by the user before each use and, additionally, by a competent person, other than the user, at interval of no more than one year for:
  - **Absence** or illegibility of markings.
  - **Absence** of any elements affecting the equipment form, fit or function.
  - **Evidence** of defects in, or damage to, hardware elements including cracks, sharp edges, deformation, corrosion, chemical attack, excessive heating, alteration and excessive wear.
  - **Evidence** of defects in or damage to strap or ropes including fraying, unsplicing, unlaying, kinking, knotting, roping, broken or pulled stitches, excessive elongation, chemical attack, excessive soiling, abrasion, alteration, needed or excessive lubrication, excessive aging and excessive wear.
2. Inspection criteria for the equipment shall be set by the user's organization. Such criteria for the equipment shall equal or exceed the criteria established by this standard or the manufacturer's instructions, whichever is greater.
3. When inspection reveals defects in, damage to, or inadequate maintenance of equipment, the equipment shall be permanently removed from service or undergo adequate corrective maintenance, by the original equipment manufacturer or their designate, before return to service.

### ***Maintenance and Storage***

1. Maintenance and storage of equipment shall be conducted by the user's organization in accordance with the manufacturer's instructions. Unique issues, which may arise due to conditions of use, shall be addressed with the manufacturer.
2. Equipment which is in need of, or scheduled for, maintenance shall be tagged as unusable and removed from service.
3. Equipment shall be stored in a manner as to preclude damage from environmental factors such as temperature, light, UV, excessive moisture, oil, chemicals and their vapors or other degrading elements.

The follow models also apply to this instruction:

1100381	1113022	1113115	1113234	1113326	1113410	1113514	1113593	1113672	1113763
1100382	1113023	1113118	1113240	1113327	1113411	1113515	1113594	1113673	1113764
1100383	1113024	1113120	1113241	1113328	1113412	1113516	1113595	1113674	1113765
1100384	1113025	1113121	1113242	1113329	1113413	1113517	1113596	1113675	1113766
1100385	1113026	1113124	1113243	1113330	1113414	1113518	1113597	1113676	1113767
1100397	1113027	1113124H	1113244	1113331	1113415	1113519	1113598	1113677	1113768
1100920	1113028	1113127	1113245	1113332	1113416	1113520	1113599	1113678	1113769
1100921	1113030	1113127H	1113246	1113333	1113417	1113521	1113600	1113679	1113770
1100922	1113031	1113129	1113250	1113334	1113418	1113522	1113601	1113680	1113771
1100923	1113032	1113130	1113251	1113335	1113419	1113523	1113602	1113681	1113772
1101739	1113033	1113130H	1113252	1113336	1113420	1113524	1113603	1113682	1113773
1101742	1113034	1113133	1113253	1113337	1113421	1113525	1113604	1113683	1113774
1101743	1113036	1113135	1113254	1113338	1113422	1113526	1113605	1113684	1113775
1101744	1113037	1113136	1113255	1113339	1113423	1113527	1113606	1113685	1113776
1101749	1113038	1113137	1113256	1113345	1113424	1113528	1113607	1113686	1113777
1101759	1113039	1113138	1113257	1113346	1113425	1113529	1113608	1113687	1113778
1101919	1113040	1113139	1113258	1113347	1113426	1113530	1113609	1113688	1113779
1101921	1113043	1113140	1113259	1113348	1113427	1113531	1113610	1113689	1113780
1101922	1113045	1113142	1113260	1113350	1113428	1113532	1113611	1113690	1113781
1101923	1113046	1113143	1113261	1113351	1113429	1113533	1113612	1113691	1113782
1101924	1113049	1113145	1113262	1113352	1113434	1113534	1113613	1113692	1113783
1101962	1113052	1113148	1113263	1113353	1113435	1113535	1113614	1113693	1113784
1102016	1113055	1113150	1113269	1113354	1113436	1113536	1113615	1113694	1113785
1102017	1113058	1113151	1113270	1113355	1113437	1113537	1113616	1113695	1113786
1102018	1113060	1113151H	1113271	1113356	1113438	1113538	1113617	1113696	1113787
1102019	1113061	1113154	1113272	1113357	1113439	1113539	1113618	1113697	1113788
1102023	1113061H	1113154H	1113273	1113358	1113443	1113540	1113619	1113698	1113789
1102024	1113064	1113157	1113274	1113359	1113444	1113541	1113620	1113703	1113794
1102705	1113064H	1113157H	1113275	1113360	1113459	1113542	1113621	1113704	1113795
1102706	1113067	1113160	1113276	1113361	1113460	1113543	1113622	1113705	1113796
1102707	1113067H	1113160H	1113277	1113362	1113461	1113544	1113623	1113706	1113797
1102708	1113068	1113163	1113278	1113363	1113462	1113545	1113624	1113707	1113798
1102709	1113069	1113164	1113279	1113364	1113467	1113546	1113625	1113708	1113799
1102714	1113070	1113166	1113280	1113365	1113468	1113547	1113626	1113709	1113800
1103070	1113070H	1113167	1113281	1113366	1113469	1113548	1113627	1113710	1114000
1103071	1113071	1113168	1113282	1113367	1113470	1113549	1113628	1113711	1114000H
1103072	1113072	1113170	1113283	1113368	1113471	1113550	1113629	1113712	1114001
1103072H	1113073	1113171	1113284	1113369	1113472	1113551	1113630	1113713	1114001H
1103073	1113073H	1113172	1113285	1113370	1113473	1113552	1113631	1113714	1114002
1103073H	1113074H	1113173	1113286	1113371	1113474	1113553	1113632	1113715	1114002H
1103074	1113075	1113180	1113287	1113372	1113475	1113554	1113633	1113716	1114004
1103084	1113076	1113181	1113288	1113373	1113476	1113555	1113634	1113717	1114004H
1103085	1113076H	1113182	1113289	1113374	1113477	1113556	1113635	1113718	1114005
1103086	1113077	1113185	1113290	1113375	1113478	1113557	1113636	1113719	1114005H
1103087	1113078	1113186	1113290H	1113375H	1113479	1113558	1113637	1113720	1114006
1103088	1113079	1113187	1113291	1113376	1113480	1113559	1113638	1113721	1114006H
1103089	1113079H	1113188	1113291H	1113376H	1113481	1113560	1113639	1113722	1114008
1103094	1113080	1113189	1113292	1113377	1113482	1113561	1113640	1113723	1114008H
1103095	1113081	1113190	1113292H	1113377H	1113483	1113562	1113641	1113724	1114009
1103581	1113082	1113190H	1113293	1113378	1113484	1113563	1113642	1113725	1114009H
1112426	1113082H	1113191	1113293H	1113378H	1113485	1113564	1113643	1113726	1114010
1112427	1113083	1113191H	1113294	1113379	1113486	1113565	1113644	1113727	1114010H
1112428	1113085	1113192	1113295	1113380	1113487	1113566	1113645	1113728	1114030
1112429	1113085H	1113192H	1113296	1113381	1113488	1113567	1113646	1113729	1114031
1112430	1113086H	1113193	1113297	1113382	1113489	1113568	1113647	1113730	1114032
1113000	1113087H	1113193H	1113298	1113383	1113490	1113569	1113648	1113731	1114033
1113001	1113088	1113194	1113303	1113384	1113491	1113570	1113649	1113740	1114058
1113001H	1113088H	1113195	1113304	1113385	1113492	1113571	1113650	1113741	1114058H
1113004	1113090	1113196	1113305	1113386	1113493	1113572	1113651	1113742	1114059
1113004H	1113091	1113197	1113306	1113387	1113494	1113573	1113652	1113743	1114059H
1113007	1113092	1113198	1113307	1113388	1113495	1113574	1113653	1113744	1114067
1113007H	1113093	1113199	1113308	1113389	1113496	1113575	1113654	1113745	1114068
1113008	1113094	1113200	1113309	1113393	1113497	1113576	1113655	1113746	1114069
1113009	1113095	1113201	1113310	1113394	1113498	1113577	1113656	1113747	1114070
1113010	1113096	1113202	1113311	1113395	1113499	1113578	1113657	1113748	1114071
1113010H	1113097	1113203	1113312	1113396	1113500	1113579	1113658	1113749	1114072
1113011	1113098	1113204	1113313	1113397	1113501	1113580	1113659	1113750	1114073
1113012	1113099H	1113205	1113314	1113398	1113502	1113581	1113660	1113751	1114074
1113013	1113100	1113206	1113315	1113399	1113503	1113582	1113661	1113752	1114092
1113013H	1113101H	1113207	1113316	1113400	1113504	1113583	1113662	1113753	
1113014	1113102H	1113208	1113317	1113401	1113505	1113584	1113663	1113754	
1113014H	1113103	1113209	1113318	1113402	1113506	1113585	1113664	1113755	
1113015	1113104H	1113220	1113319	1113403	1113507	1113586	1113665	1113756	
1113016	1113105	1113228	1113320	1113404	1113508	1113587	1113666	1113757	
1113016C	1113106	1113229	1113321	1113405	1113509	1113588	1113667	1113758	
1113018	1113106H	1113230	1113322	1113406	1113510	1113589	1113668	1113759	
1113019	1113107H	1113231	1113323	1113407	1113511	1113590	1113669	1113760	
1113020	1113109	1113232	1113324	1113408	1113512	1113591	1113670	1113761	
1113021	1113112	1113233	1113325	1113409	1113513	1113592	1113671	1113762	

## U.S. PRODUCT WARRANTY, LIMITED REMEDY AND LIMITATION OF LIABILITY

**WARRANTY:** THE FOLLOWING IS MADE IN LIEU OF ALL WARRANTIES OR CONDITIONS, EXPRESS OR IMPLIED, INCLUDING THE IMPLIED WARRANTIES OR CONDITIONS OF MERCHANTABILITY OR FITNESS FOR A PARTICULAR PURPOSE.

Unless otherwise provided by applicable law, 3M fall protection products are warranted against factory defects in workmanship and materials for a period of one year from the date of installation or first use by the original owner.

**LIMITED REMEDY:** Upon written notice to 3M, 3M will repair or replace any product determined by 3M to have a factory defect in workmanship or materials. 3M reserves the right to require product be returned to its facility for evaluation of warranty claims. This warranty does not cover product damage due to wear, abuse, misuse, damage in transit, failure to maintain the product or other damage beyond 3M's control. 3M will be the sole judge of product condition and warranty options.

This warranty applies only to the original purchaser and is the only warranty applicable to 3M's fall protection products. Please contact 3M's customer service department at 800-328-6146 or via email at 3MfallProtection@mmm.com for assistance.

**LIMITATION OF LIABILITY:** TO THE EXTENT PERMITTED BY APPLICABLE LAW, 3M IS NOT LIABLE FOR ANY INDIRECT, INCIDENTAL, SPECIAL OR CONSEQUENTIAL DAMAGES INCLUDING, BUT NOT LIMITED TO LOSS OF PROFITS, IN ANY WAY RELATED TO THE PRODUCTS REGARDLESS OF THE LEGAL THEORY ASSERTED.

# 3M



Fall Protection

### USA

3833 SALA Way  
Red Wing, MN 55066-5005  
Toll Free: 800.328.6146  
Phone: 651.388.8282  
Fax: 651.388.5065  
3Mfallprotection@mmm.com

### Brazil

Rua Anne Frank, 2621  
Boqueirão Curitiba PR  
81650-020  
Brazil  
Phone: 0800-942-2300  
falecoma3m@mmm.com

### Mexico

Calle Norte 35, 895-E  
Col. Industrial Vallejo  
C.P. 02300 Azcapotzalco  
Mexico D.F.  
Phone: (55) 57194820  
3msaludocupacional@mmm.com

### Colombia

Compañía Latinoamericana de Seguridad S.A.S.  
Carrera 106 #15-25 Interior 105 Manzana 15  
Zona Franca - Bogotá, Colombia  
Phone: 57 1 6014777  
fallprotection-co@mmm.com

### Canada

260 Export Boulevard  
Mississauga, ON L5S 1Y9  
Phone: 905.795.9333  
Toll-Free: 800.387.7484  
Fax: 888.387.7484  
3Mfallprotection-ca@mmm.com

### EMEA (Europe, Middle East, Africa)

**EMEA Headquarters:**  
5a Merse Road  
North Moons Moat  
Redditch, Worcestershire  
B98 9HL UK  
Phone: + 44 (0)1527 548 000  
Fax: + 44 (0)1527 591 000  
informationfallprotection@mmm.com

### France:

Le Broc Center  
Z.I. 1re Avenue - BP15  
06511 Carros Le Broc Cedex  
France  
Phone: + 33 04 97 10 00 10  
Fax: + 33 04 93 08 79 70  
informationfallprotection@mmm.com

### Australia & New Zealand

95 Derby Street  
Silverwater  
Sydney NSW 2128  
Australia  
Phone: +(61) 2 8753 7600  
Toll-Free : 1800 245 002 (AUS)  
Toll-Free : 0800 212 505 (NZ)  
Fax: +(61) 2 8753 7603  
anzfallprotectionsales@mmm.com

### Asia

**Singapore:**  
1 Yishun Avenue 7  
Singapore 768923  
Phone: +65-6450 8888  
Fax: +65-6552 2113  
TotalFallProtection@mmm.com

### Shanghai:

19/F, L'Avenue, No.99 Xian Xia Rd  
Shanghai 200051, P R China  
Phone: +86 21 62539050  
Fax: +86 21 62539060  
3MFallProtection-CN@mmm.com

### Korea:

3M Korea Ltd  
20F, 82, Uisadang-daero,  
Yeongdeungpo-gu, Seoul  
Phone: +82-80-033-4114  
Fax: +82-2-3771-4271  
TotalFallProtection@mmm.com

### Japan:

3M Japan Ltd  
6-7-29, Kitashinagawa, Shinagawa-ku, Tokyo  
Phone: +81-570-011-321  
Fax: +81-3-6409-5818  
psd.jp@mmm.com

**3M.com/FallProtection**

