



GPD 506 / Modbus[®] RTU Technical Manual

efesotomasyon.com



Technical References

Refer to the following publications for further information about the GPD 506/P5:

- GPD 506/P5 Technical Manual
Publication TM 4506
- RS-232C/485 Interface Card Installation Sheet
Publication 02Y00025-0409

Refer to the following Modicon publication for technical information on Modbus RTU protocol:

- Modicon Modbus Protocol Reference Guide
Publication PI-MBUS-300 Rev. D

Support

Technical Support Center-

Provide telephone assistance related to installation, start-up, programming, and troubleshooting drives and communication products. For technical phone support call: (800) YASKAWA (800-927-5292)

Contents

	Technical References / Support	i
	Contents	1
Chapter 1	GPD 506/P5 and Serial Communication	1-1
	Introduction to GPD 506 Modbus RTU Communication	1-2
	Standard RS-232 C/D Serial Communication	1-2
	The RS-232 C/D to RS-485 Converter Board	1-3
	Figure 1-1. The CM086 Board	1-3
Chapter 2	RS-232 C/D Serial Communication	2-1
	RS-232 C/D Serial Communication	2-2
	Figure 2-1. RS-232 C/D Pin-out at 2CN Connector	2-2
Chapter 3	Installation of CM086 Board	3-1
	Installation Procedure	3-2
	Figure 3-1. Position of the CM086 Board on the GPD 506	3-2
Chapter 4	Wiring of the CM086 Board	4-1
	Connection of Multiple Drives	4-2
	Figure 4-1. CM086 Connection Diagram	4-2
	Wiring Instructions	4-3
	Figure 4-2. Shield Termination	4-3
	Table 4-1. Functions of Terminal Block TC1	4-3
	Table 4-2. Applicable Wire Sizes for Terminal Block TC1	4-3
	Terminating Resistors	4-4
	Figure 4-3. SW1 Location on the CM086 Board	4-4
Chapter 5	Setting GPD 506 Parameters for Communication	5-1
	Run/Stop and Frequency Selection	5-2
	Communication Set up Parameters	5-3
	“ENTER” Command	5-5
Chapter 6	The Message Format	6-1
	Message Functions	6-2
	Read Multiple Registers - 03h	6-3
	Loop-back Test - 08h	6-6
	Write Multiple Registers - 10h	6-8
	No Response Message	6-11
	CRC-16	6-11
Chapter 7	Registers	7-1
	Simultaneous Broadcast Registers	7-2
	Command Registers	7-3
	Monitor Registers	7-4
	Drive Parameter Registers	7-8
	Special Registers	7-20

Chapter 8	Error Codes and Troubleshooting	8-1
	Communication Error (CE)	8-2
	Modbus Error Codes	8-2
	Figure 8-1. Fault Response Message	8-2
Chapter 9	Command Priority	9-1
	Command Priority	9-2
	Table 9-1. Set up for Serial Communication Control	9-3
	Table 9-2. Set up for External Terminals Control	9-4
	Table 9-3. Set up for Digital Operator Control	9-5
Appendix A	Product Specifications	A-1
Appendix B	Spare Parts List	B-1
Appendix C	RS232-C/D Comments	C-1

Chapter 1

GPD 506/P5 and Serial Communication

- Introduction to GPD 506/P5 Modbus RTU Communication
- Standard RS-232 C/D Serial Communication
- The RS-232 C/D to RS-485 Converter Board
- Figure 1-1. The CM086 Board

Introduction to GPD 506/P5 Modbus RTU Communication

This manual describes the set-up and protocol for Modbus Communication. The GPD 506 offers RS-232 C/D serial communication as standard, and RS-485 as an option.

The Modbus RTU protocol requires that the controller communicates using a master-slave technique, in which only one device (the master) can initiate transactions. The other devices (the slaves) respond by supplying the requested data to the master, or by taking the action requested. The GPD 506 drive must act in the slave mode.

A complete understanding of drive programming and operation is required before attempting serial communication operation. A full discussion of programming and operation is covered in the GPD 506 technical manual - TM 4506.

GPD 506 / Modbus RTU Specifications

The data that may be sent or received from the drive consists of:

- Run Command
- Frequency Reference
- Fault Contents
- Drive Status
- Drive Parameter Settings

The following table illustrates whether the serial communication specifications are fixed or user selectable. If the specification is fixed, the fixed value is shown in the last column. If the specification is selectable, the range of allowed values is shown in the last column.

Communication Specification	Fixed or Selectable	Range
Baud Rate	Selectable	2400, 4800, or 9600 bps
Data Bit	Fixed	8
Parity	Selectable	None, Even, or Odd
Stop Bit	Fixed	1
Nodes	RS-232 C/D	point-to-point only
Nodes	Selectable for RS-485	maximum of 31 nodes

Standard RS-232 C/D Serial Communication

The GPD506 drive offers RS-232 C/D serial communications as a standard feature of the drive. RS-232 C/D has a maximum transmission distance of 50 feet. RS-232 C/D allows point-to-point communications only. The specifications for wiring and pin outs for RS-232 C/D are presented in Chapter 2.

The RS-232 C/D to RS-485 Converter Board

The GPD 506 offers RS-485 serial communications as an option. RS-485 allows a maximum transmission distance of 4000 feet and is capable of multi-drop (multiple devices) communication.

To obtain RS-485 communications an optional converter board must be purchased. This RS-232 C/D to RS-485 Converter Board is represented by MagneTek part number CM086.

Read this manual thoroughly before installation, operation, maintenance, and inspection of the CM086 Option Board.

CAUTION

The CM086 option board employs CMOS technology. Use proper electrostatic discharge (ESD) procedures when handling this board to avoid possible damage due to static electricity.

The CM086 board is used to convert the drive's RS-232 C/D standard function to offer RS-485 interface. The following diagram illustrates the CM086 board. (The figure is not actual size.)

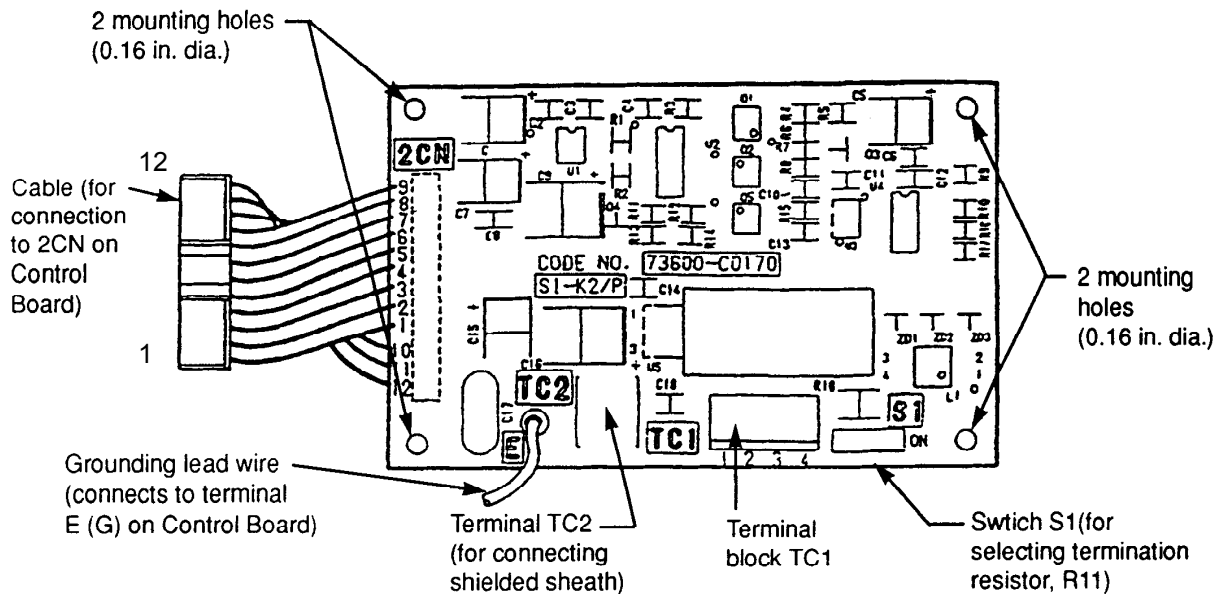

Figure 1-1. The CM086 Board

Chapter 2

RS-232 C/D Serial Communication

- RS-232 C/D Serial Communication
- Figure 2-1. RS-232 C/D Pin out at the 2CN Connector

RS-232 C/D Serial Communication

RS-232 C/D Serial Communication is accessed through connector 2CN on the GPD 506 control board. Pin 1 on the 2CN connector is for the transmission of data, Pin 2 is for the receipt of data, and pins 6 and 7 are for the ground connection. The RS-232 C/D pin out is shown in the diagram below.

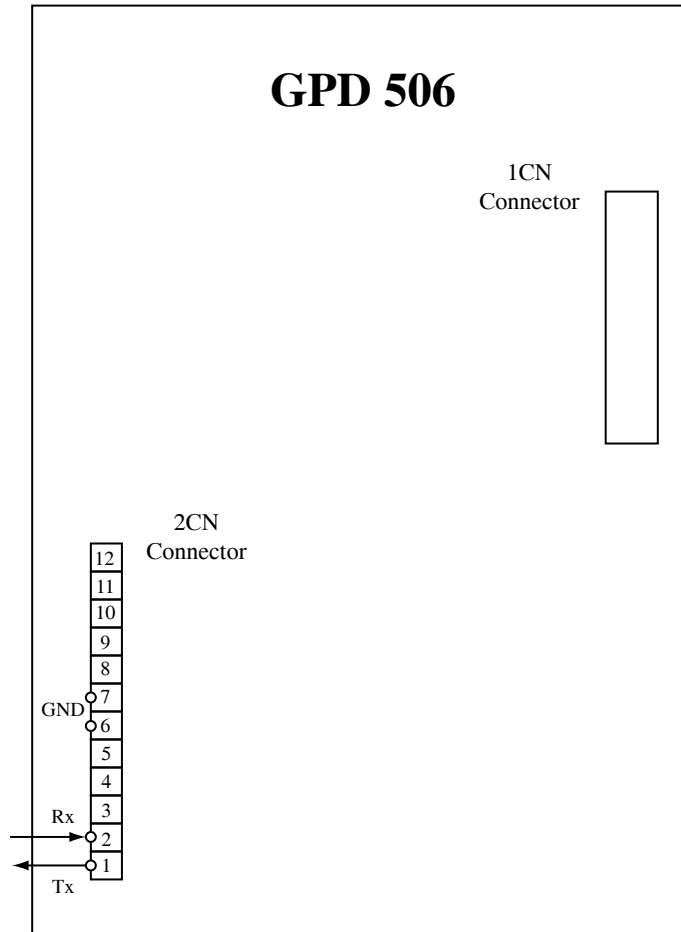

Figure 2-1. RS-232 C/D Pin-out at 2CN Connector

Cable Specifications:

- cable should be a shielded, thin twisted wire 22-28 AWG
- cable pin out is as follows:

Computer - 9 Pin Female D shell	GPD 506 – 12 Pin Female Connector for 2CN
3 - Tx	2 - Rx
2 - Rx	1 - Tx
5 - GND	6 and 7 - GND

-pin out for devices other than a computer (PC), such as a PLC, may vary.

Chapter 3

Installation of the CM086 Board

- Installation Procedure
- Figure 3-1. Position of the CM086 Board on the GPD 506 control board

Installation Procedure

These procedures should be followed when installing the CM086 board into the GPD 506 drive.

1. Turn the main power OFF to the drive, and wait the specified length of time shown on the front cover. Remove the front cover of the drive to verify that the CHARGE lamp is off.
2. Position the CM086 board onto the control board of the drive, lining up the four (4) spacer holes on the board with the four (4) plastic stand-offs on the drive. Snap the CM086 board onto the stand-offs tightly.
3. Plug the connector from the CM086 board into location 2CN on the control board. Be sure to correctly align the connection locking tab with its mating part on 2CN.
4. Connect the green wire (labeled 'E') from the CM086 board to the ground wire post or ground terminal (also labeled 'E') on the drive.
5. After installing the CM086 board onto the drive, connect with peripheral devices and replace the cover of the drive.

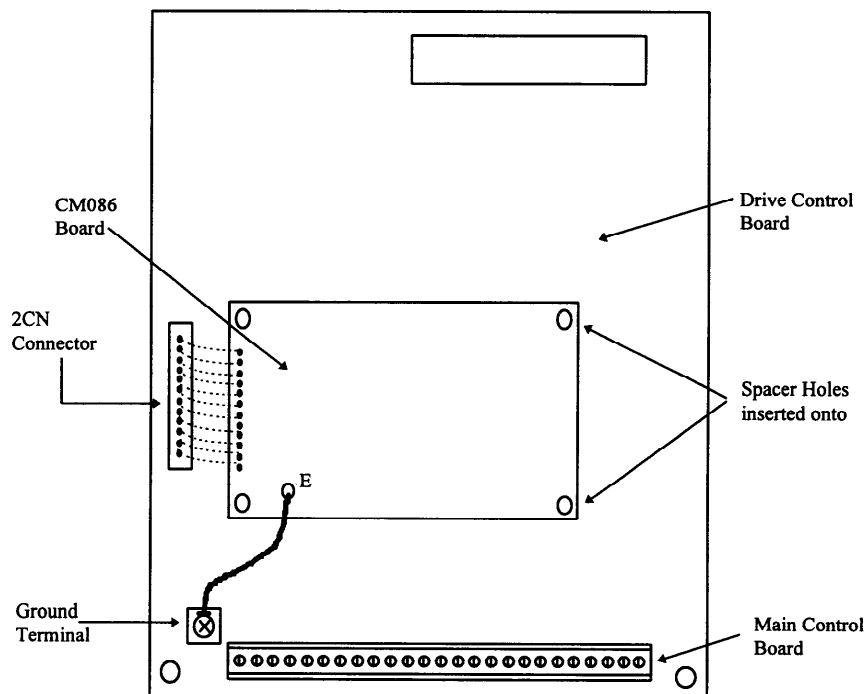

Figure 3-1. Position of the CM086 Board on the GPD 506 Drive

Chapter 4

Wiring of the CM086 Board

- Connection of Multiple Drives
- Figure 4-1. CM086 Connection Diagram
- Wiring Instructions
- Figure 4-2. Shielded Wire Termination
- Table 4-1. Functions on Terminal Block TC1
- Table 4-2. Applicable Wire Size for TC1
- Terminating Resistor
- Figure 4-3. SW1 Location on the CM086 Board

Connection of Multiple Drives

With the RS-485 Conversion Board (CM086), multiple drives may be connected together for a multiple drive communication system. The following diagram illustrates the connection between multiple CM086 boards.

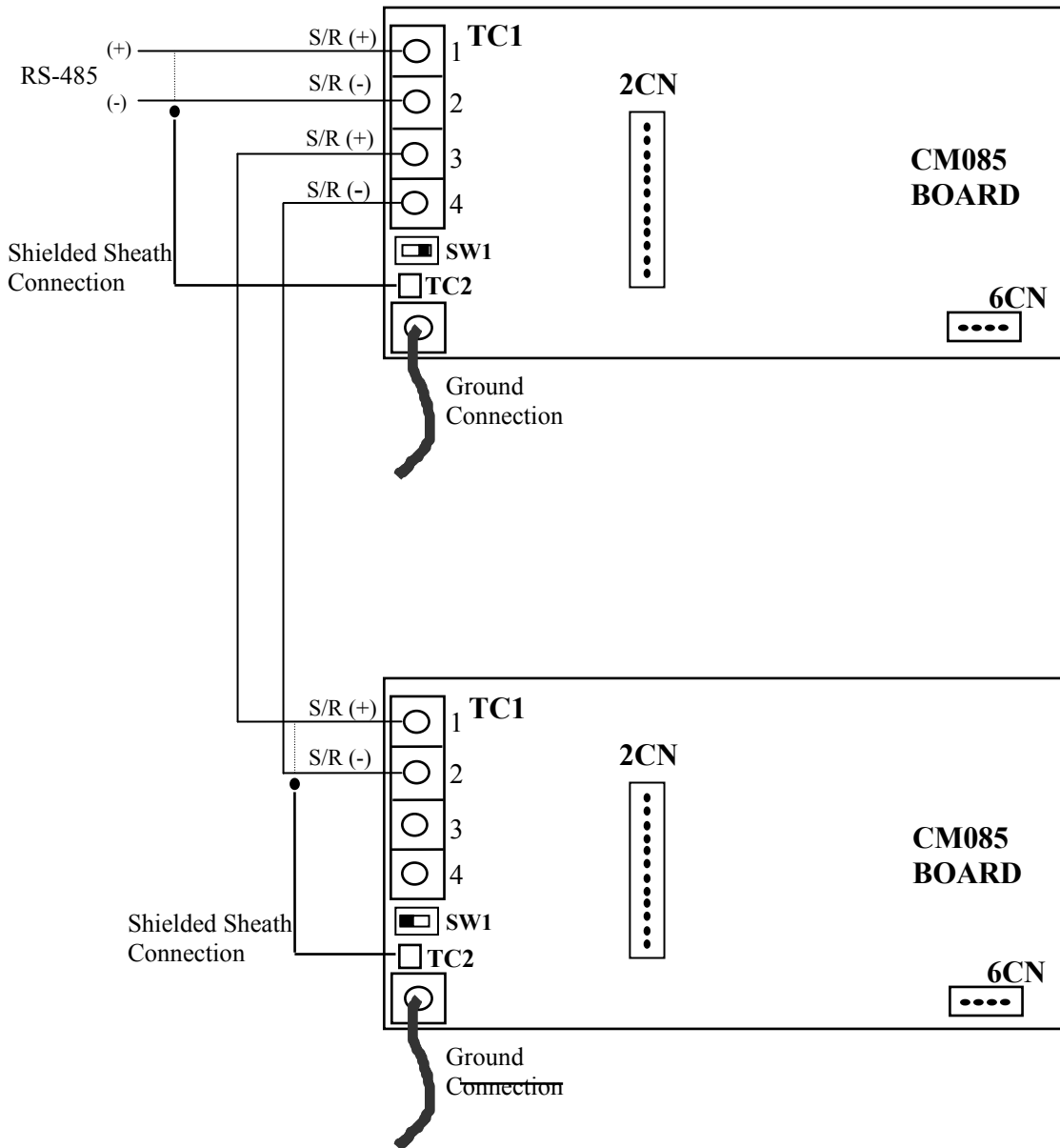

Figure 4-1. CM086 Connection Diagram

Wiring Instructions

1. Locate terminal block at TC1 on the CM086 board. (See Figure 1-1 in this manual.) TC1 should have 4 terminal locations (1, 2, 3 and 4) on it.
2. A twisted shielded wire should be used for connection to TC1. The shielded wire should be separated and connected per the drawing below to eliminate interference due to noise.

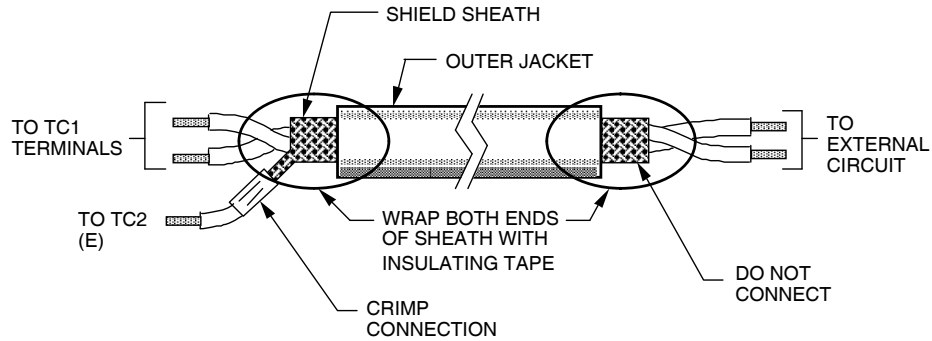

Figure 4-2. Shielded Wire Termination

3. The TC1 terminal block functions are described in the table below.

Terminal Block Symbol	Pin No.	Functions		Remarks
TC1	1	S/R (+)	RS-485 input/output (+)	Use as input at parallel connection
	2	S/R (-)	RS-485 input/output (-)	
	3	S/R (+)	RS-485 input/output (+)	Use as output at parallel connection
	4	S/R (-)	RS-485 input/output (-)	
TC2	Shield connection terminal			-

Table 4-1. Functions of Terminal Block TC1

4. It is important that an appropriate wire size is selected. When the wire gauge is too thick, it may apply pressure to the CM086 board and cause failure. When the wire gauge is too thin, it may lead to incomplete contact or a break in the wire. The table below indicates the suggested wire size to be used at TC1.

	[mm ²]	AWG	I [A]	VAC [V]
Twisted wire	1.0	16	12	125
Single wire	1.5	16	12	125
UL	-	22-16	10	300
CSA	-	28-16	10	300
CSA	-	28-16	10	150

Table 4-2. Applicable Wire Sizes for Terminal Block TC1

5. When stripping the wire end to be connected at TC1, approximately 5.5 mm of wire should be exposed to make a good connection.
- 6.

Terminating Resistors

Dip Switch SW1 is located on the lower right hand corner of the CM086 board. (See below) When SW1 is on, a termination resistor (100 Ohms) is connected between S/R (+) and S/R (-).

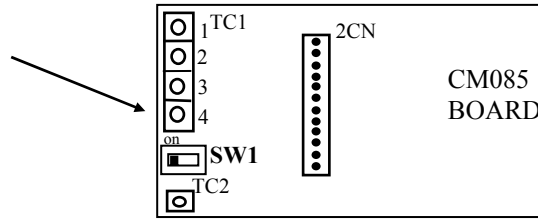
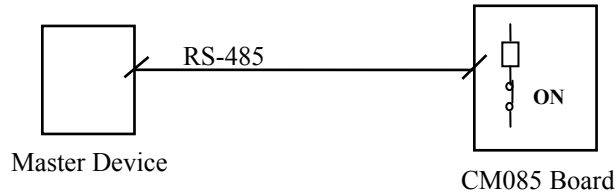
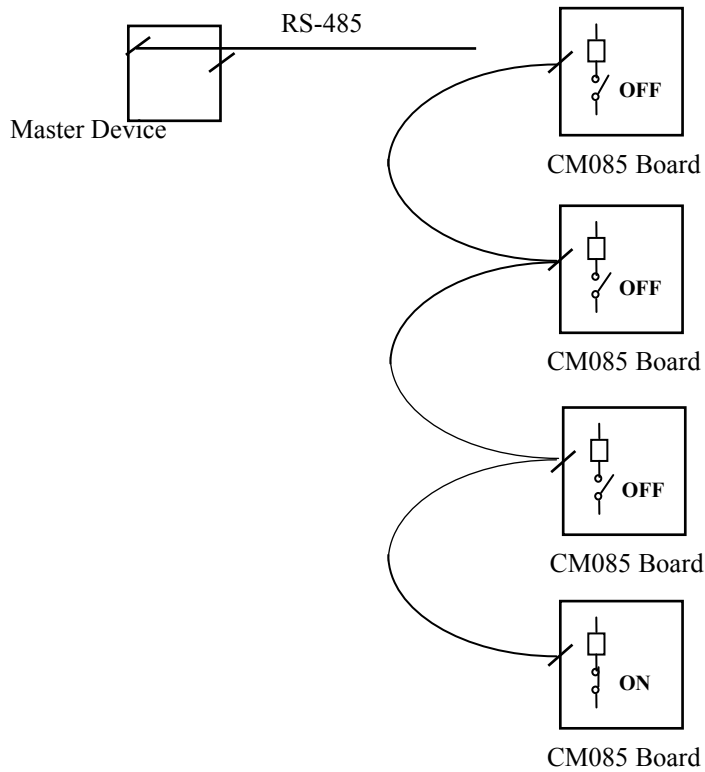

Figure 4-3. SW1 Location on the CM086 Board

For one-to-one connections of the CM086 card and a master device set SW1 to ON as shown below.



If multiple CM086 cards are connected to a master device, set SW1 on the last CM086 board to ON as shown below.



Chapter 5

Setting GPD 506 Parameters for Communication

- Run/Stop and Frequency Selection
- Communication Set up Parameters
- 'ENTER' Command

Run/Stop and Frequency Selection

The run/stop command and frequency reference command can be accessed through serial communication, the digital operator, or the external terminals. The origin of the run/stop command does not have to be the same as the origin for the frequency reference command. Parameter n002 allows you to set up the origin of the run/stop and frequency reference. Parameter n002 is Modbus register number 102h. The chart shown below illustrates the possible run/stop and frequency reference selections.

Setting Value of n002 (in hex)	Run/Stop Command	Frequency Reference Command
0	Digital Operator	Digital Operator
1	External Terminals	Digital Operator
2	Digital Operator	External Terminals
3	External Terminals	External Terminals
4	Digital Operator	Serial Communication
5	External Terminals	Serial Communication
6	Serial Communication	Serial Communication
7	Serial Communication	Digital Operator
8	Serial Communication	External Terminals
9-F	unused	unused

The default setting of parameter n002 is '3'.

Communication Set up Parameters

The GPD 506 has parameters used to set up for serial communication rather than dip switches. These communication set up parameters are numbers n101 through n106.

Parameter n101 and n102 determine how the drive will respond to a communication error (CE). A communication error can occur only after communication has been established between the master and the drive. The drive waits for the master to initiate communication.

The message data is always checked for CRC, parity, overrun, framing, and overflow. If the data has discrepancies in any of these areas a communication error will occur. If the drive does not receive a message (addressed to its appropriate slave address set up in parameter n104) within a period of 2 seconds, a time-out occurs. A time-out can also cause a communication error if it is enabled (via parameter n101).

Parameter n101 - Modbus Time-out Detection Selection

A time-out is a loss of communications for 2 seconds. Parameter n101 (or Modbus Register 165h) is used to enable or disable the Time-out Detection.

0 = Time-out Detection is disabled.

1 = Time-out Detection is enabled.

The default setting of parameter n101 is a '1'.

Parameter n102 - Modbus Communication Error Stop Method Selection

Parameter n102 (or Modbus Register 166h) is used to determine the method of stopping the motor if there is a communication error. The table below indicates the stopping methods that can be used when a communication error occurs.

Setting Value (in hex)	Stopping Method
0	Decelerate to stop (at decel time 1)
1	Coast to stop
2	Decelerate to stop (at decel time 2)
3	Continue Operation (Alarm display)

The default setting of parameter n102 is a '1'.

Parameter n103 - Modbus Frequency Unit Selection

Parameter n103 (or Modbus Register 167h) is used to select the units that the frequency should be given in. The table below indicates the units that may be used to represent frequency.

Setting Value (in hex)	Units for Frequency
0	0.1 Hz
1	0.01 Hz
2	100% / 30000
3	0.01%

The default setting of parameter n103 is a '0'.

Parameter n104 - Modbus Slave Address

Parameter n104 (or Modbus Register 168h) is used to set the Modbus slave address of the that particular GPD 506 drive. The slave address can be any number from 1 to 31 (dec.) or 1 to 1F (hex). However, two nodes may not have the same address. The default setting for parameter n104 is a '1'.

Parameter n105 - Modbus Baud Rate Selection

Parameter n105 (or Modbus Register 169h) is used to select the baud rate. The table below indicates the baud rates that may be selected.

Setting Value (in hex)	Baud Rate Selection
0	2400 bps
1	4800 bps
2	9600 bps

The default setting of parameter n105 is a '2'.

Parameter n106 - Modbus Parity Selection

Parameter n106 (or Modbus Register 16Ah) is used to select the parity. The table below indicates the parity that may be selected.

Setting Value (in hex)	Parity Selection
0	No parity
1	Even parity
2	Odd parity

The default setting of parameter n106 is a '0'.

<p style="text-align: center;">Note: Power must be cycled to the drive, to make the serial communication set up parameters effective.</p>

'ENTER' Command

The GPD 506 has two types of memory: 'Volatile' and 'Non-Volatile'. Data held in the Volatile memory will be lost when power is removed from the drive. Data held in Non-Volatile memory will be retained when power is removed from the drive. Different types of registers are stored in different areas of memory.

Command Data:

The command registers (001h to 009h) are stored in Volatile memory. When writing to a command register the new data becomes active immediately. In the case of a power loss all data stored in these registers will **not** be retained.

Monitor Data:

The monitor registers (020h to 03Dh) are stored in Volatile memory. These registers can not be written to (read only registers). Any data read from the monitor registers will **not** be retained during a power loss situation.

Parameter Data:

The parameter registers (101h to 174h) are stored in Non-Volatile memory. When writing new data to parameter registers, the new data is written immediately, however the new data is stored in Volatile memory. Sending the 'ENTER' command will save the new data in Non-Volatile memory. The new data takes effect after the drive has been stopped and restarted, except for registers 112h to 115h, in which case the data is effective immediately.

The 'ENTER' command is accomplished by writing the value of '0' to register 900h.

If power loss occurs after the new data has been saved into Non-Volatile memory, by using the 'ENTER' command, the data will be retained.

NOTE
Use the 'ENTER' command only when necessary! The life of the Non-Volatile EEPROM on the GPD 506 will support a finite number of operations. This means that the 'ENTER' command can only be used a maximum of a 100,000 times to store data in the EEPROM. After the specified number of operations, the EEPROM may fault (CPF4) requiring the GPD 506 control board to be replaced.

efesotomasyon.com

Chapter 6

The Message Format

- Message Functions
- Read Multiple Registers
- Loop Back Test
- Write Multiple Registers
- No Response Message
- CRC-16

Message Functions

In communicating to the GPD 506 drive via Modbus RTU, there are three message functions available. The master specifies the function to be executed by the slave according to the function code. The following table shows the types of function codes available, and the length (quantity) and contents of the message according to the function.

Function Code (hex)	Function	Command Message		Response Message (Normal)	
		min. (bytes)	max. (bytes)	min. (bytes)	max. (bytes)
03h	Read Multiple Registers	8	8	7	21
08h	Loop-back test	8	8	8	8
10h	Write Multiple Registers	11	25	8	8

The message format varies depending upon the function of the message. For each function, there is a command message from the master and a response message initiated from the slave. The following sections review the format of the command message and the response message for each function.

Read Multiple Registers - 03h

The multiple register read function (03h) allows the master to request information from the slave. The command message of a multiple register read is structured as shown below.

Command Message

SLAVE ADDRESS		02h
FUNCTION CODE		03h
START- ING REGISTER NO.	UPPER	00h
	LOWER	20h
QTY.	UPPER	00h
	LOWER	04h
CRC-16	LOWER	45h
	UPPER	F0h

Each GPD 506 slave address is set in advance by the drive parameter n104. Valid slave addresses must be in the range of 1 to 31 decimal (1 to 1F hex). No two slaves may have the same address. The master addresses the slave by placing the slave address in the address field of the message. In the command message above, the slave is addressed at 2.

The function code of this message is 03h (read multiple registers).

The starting number is the first register to be read. In the command message above the starting register is 20h, indicating that the first register is the Status Signal. A listing of the GPD 506 registers is shown in Chapter 7, Registers.

The quantity indicates how many consecutive registers are to be read. The quantity may range from 1 to 8 registers. If the quantity is greater than 8, an error code of '3' is returned in the fault response message. In this command message, there are four consecutive registers to be read: 20h-Status Signal, 21h-Drive Fault Contents, 22h-Communication Data Link Status, and 23h-Frequency Reference.

A CRC-16 value is generated from a calculation using the values of the address, function code, and data sections of the message. The procedure for calculating a CRC-16 is presented at the end of this chapter. When the slave receives the command message, it calculates a CRC-16 value and compares it to the one in CRC-16 field of the command message. If these two CRC-16 values are the same, the slave has received the proper command message. If the two CRC-16 values are not the same, the slave will not respond.

If the command message has a valid slave address, function code, starting register, and quantity value, the slave will respond with a normal response message. If the command message has an invalid slave address, function code, starting register, and/or quantity the slave will respond with a fault response message.

Normal Response Message

SLAVE ADDRESS		02h	
FUNCTION CODE		03h	
NO. OF DATA BYTES		08h	
START- ING REGISTER CONTENTS	UPPER	00h	The starting register, 20h (Status Signal), has a value of 4. (Drive Ready)
	LOWER	04h	
NEXT REGISTER CONTENTS	UPPER	00h	The next register, 21h (Drive Fault Content), has a value of 0 (no drive faults).
	LOWER	00h	
NEXT REGISTER CONTENTS	UPPER	00h	The next register, 22h (Communication Data Link Status), has a value of 0 (no communication errors).
	LOWER	00h	
NEXT REGISTER CONTENTS	UPPER	17h	The next register, 23h (Frequency Reference), has a value of 1770h or 6000 dec. (60.00 Hz).
	LOWER	70h	
CRC-16	LOWER	ACh	
	UPPER	1Ch	

The normal response message contains the same slave address and function code as the command message, indicating to the master, which slave is responding and to what type of function it is responding.

The number of data bytes is the number of data bytes returned in the response message. The number of data bytes is actually the quantity (in the command message) multiplied by 2, since there are two bytes of data in each register.

The data section of the response message contains 8 upper and 8 lower bits of data for each register that has been read from the drive.

A CRC-16 value is generated from a calculation using the values of the address, function code, number of data bytes, and register data sections of the message. The procedure for calculating a CRC-16 value is presented at the end of this chapter. When the master receives the response message, it calculates a CRC-16 value and compares it to the one in the CRC-16 field of the response message. If these two CRC-16 values are the same the master has received the proper response message.

Fault Response Message

SLAVE ADDRESS		02h
80h + FUNC. CODE		83h
ERROR CODE		02h
CRC-16	LOWER	30h
	UPPER	F1h

The fault response message contains the same slave address as the command message, indicating to the master which slave is responding.

The function code of a fault response message is actually a value of 80h plus the original function code of 03h. This indicates to the master that the message is a fault response message, instead of a normal response message.

The error code indicates where the error occurred in the command message. The value of 2h in the error code field of this fault response message, indicates that the command message requested data be read from an invalid register. A complete listing of the error codes is shown in Chapter 8, Troubleshooting and Error Codes.

A CRC-16 value is generated from a calculation using the values of the address, function code, and error code sections of the message. The procedure for calculating a CRC-16 value is described at the end of this chapter. When the master receives the fault response message it calculates a CRC-16 value and compares it to the one in the CRC-16 field of the fault response message. If these two CRC-16 values are the same the master has received the proper fault response message.

Loop-back Test - 08h

The loop-back test function (08h) is used for checking signal transmission between master and slaves. The command message format is shown below.

Command Message

SLAVE ADDRESS		01h
FUNCTION CODE		08h
TEST CODE	UPPER	00h
	LOWER	00h
DATA	UPPER	A5h
	LOWER	37h
CRC-16	LOWER	DAh
	UPPER	8Dh

Each GPD 506's slave address is set in advance by the drive parameter n106. Valid slave addresses must be in the range of 1 to 31 decimals (1 to 1F hex). No two slaves may have the same address. The master addresses the slave by placing the slave address in the address field of the message. In the command message above, the slave is addressed at 1.

The function code of this message is 08h (loop-back test).

The test code must be set to '0000'. This function specifies that the data passed in the command message is to be returned (looped back) in the response message.

The data section contains arbitrary data values. These data values are used to verify that the slave receives the correct data.

A CRC-16 value is generated from a calculation using the values of the address, function code, test code, and data sections of the message. The procedure for calculating a CRC-16 is described at the end of this chapter. When the slave receives the command message it calculates a CRC-16 value and compares it to the one in CRC-16 field of the command message. If these two CRC-16 values are the same the slave has received the proper command message. If these two CRC-16 values are not the same the slave does not respond.

If the command message has a valid slave address, function code, test code, and data value, the slave will respond with a normal response message. If the command message has an invalid slave address, function code, test code, and/or data value the slave will respond with a fault response message.

Normal Response Message

SLAVE ADDRESS		01h
FUNCTION CODE		08h
TEST CODE	UPPER	00h
	LOWER	00h
DATA	UPPER	A5h
	LOWER	37h
CRC-16	LOWER	DAh
	UPPER	8Dh

A normal response message for the loop-back test should be identical to the command message.

Fault Response Message

SLAVE ADDRESS		01h
80h + FUNC. CODE		88h
ERROR CODE		01h
CRC-16	LOWER	87h
	UPPER	C0h

The fault response message contains the same slave address as the command message, indicating to the master which slave is responding.

The function code of a fault response message is actually a value of 80h plus the original function code of 08h. This indicates to the master that the message is a fault response message, instead of a normal response message.

The error code indicates where the error occurred in the command message. A complete listing of the error codes is shown in Chapter 8, Troubleshooting and Error Codes.

A CRC-16 value is generated from a calculation using the values of the address, function code, and data sections of the message. The procedure for calculating a CRC-16 value is described at the end of this chapter. When the master receives the fault response message it calculates a CRC-16 value and compares it to the one in the CRC-16 field of the fault response message. If these two CRC-16 values are the same the master has received the proper fault response message.

Write Multiple Registers - 10h

The multiple register write function (10h) allows the master to write data to the drive's registers. The multiple register write message format is shown below.

Command Message

SLAVE ADDRESS		01h
FUNCTION CODE		10h
START- ING REGISTER NO.	UPPER	00h
	LOWER	01h
QTY.	UPPER	00h
	LOWER	02h
NO. OF DATA BYTES		04h
DATA TO FIRST REGISTER	UPPER	00h
	LOWER	01h
DATA TO NEXT REGISTER	UPPER	17h
	LOWER	70h
CRC-16	LOWER	6Dh
	UPPER	B7h

The first register, 01h (Operation Command) has a value of 01h or 1 dec. (forward run command)

The next register, 02h (Frequency Reference) has a value of 1770h or 6000 dec. (60.00 Hz)

Each GPD 506's slave address is set in advance by the drive parameter n104. Valid slave addresses must be in the range of 1 to 31 decimals (1 to 1F hex). No two slaves may have the same address. The master addresses the slave by placing the slave address in the address field of the message. In the command message above, the slave is addressed at 1.

By setting the slave address to zero (0), the master can send operation signals (register 001h) and frequency reference (register 002h) to all slaves on the network. The master can send a single transmission to all the slaves simultaneously. This is called simultaneous broadcasting. In a simultaneous broadcast message all of the slaves on the network act upon one message. Simultaneous Broadcast registers are shown in Chapter 7, Registers.

The function code of this message is 10h (write multiple registers).

The starting register number is the first register to be written to. In the command message above the starting number is 01h, indicating that the first register is the frequency reference. A listing of the GPD 506's registers is shown in Chapter 7, Registers.

The quantity indicates how many consecutive registers are to be written to. The quantity may range from 1 to 8 registers. If the quantity is greater than 8, an error code of '3' is returned in the fault response message. In this command message there is two consecutive registers to be written to: 001h-Operation Command and 002h- Frequency Reference.

The number of data bytes is the number of bytes of data to be written to the drive. The number of data bytes is actually the quantity multiplied by 2, since there are two bytes of data in each register.

The data section of the response message contains 8 upper and 8 lower bits of data for each register that is being written to.

A CRC-16 value is generated from a calculation using the values of the address, function code, starting register number, quantity, number of data bytes, and data sections of the message. The procedure for calculating a CRC-16 is described at the end of this chapter. When the slave receives the command message, it calculates a CRC-16 value and compares it to the one in CRC-16 field of the command message. If these two CRC-16 values are the same the slave has received the proper command message. If these two CRC-16 values are not the same the slave does not respond.

If the command message has a valid slave address, function code, starting register number, quantity, number of data bytes, and data values, the slave will respond with a normal response message. If the command message has an invalid slave address, function code, starting register number, quantity, number of data bytes, and/or data values the slave will respond with a fault response message.

Normal Response Message

SLAVE ADDRESS		02h
FUNCTION CODE		03h
START- ING REGISTER NO.	UPPER	00h
	LOWER	20h
QTY.	UPPER	00h
	LOWER	04h
CRC-16	LOWER	45h
	UPPER	F0h

The normal response message contains the same slave address and function code as the command message, indicating to the master what slave is responding and to what type of function it is responding.

The starting number is the first register that was written to. In the response message above the starting number is 01h, indicating that the first register is the operation command.

The quantity indicates how many consecutive registers were written to.

A CRC-16 value is generated from a calculation using the values of the address, function code, starting register number, and quantity value of the message. The procedure for calculating a CRC-16 value is described at the end of this chapter. When the master receives the response message, it calculates a CRC-16 value and compares it to the one in the CRC-16 field of the response message. If these two CRC-16 values are the same the master has received the proper response message.

Fault Response Message

SLAVE ADDRESS		01h
80h + FUNC. CODE		90h
ERROR CODE		02h
CRC-16	LOWER	CDh
	UPPER	C1h

The fault response message contains the same slave address as the command message, indicating to the master which slave is responding.

The function code of a fault response message is actually a value of 80h plus the original function code of 10h. This indicates to the master that the message is a fault response message, instead of a normal response message.

The error code indicates where the error occurred in the command message. The value of 2h in the error code field of this fault response message indicates that the command message requested data to be written to an invalid register. A complete listing of the error codes is shown in Chapter 8, Troubleshooting and Error Codes.

A CRC-16 value is generated from a calculation using the values of the address, function code, and error code sections of the message. The procedure for calculating a CRC-16 value is described at the end of this chapter. When the master receives the fault response message, it calculates a CRC-16 value and compares it to the one in the CRC-16 field of the response message. If these two CRC-16 values are the same the master has received the proper response message.

No Response Message

The slave disregards the command message and does not return the respond message in the following cases:

1. In simultaneous broadcasting of data (slave address field is 0), all slaves execute but do not respond.
2. When a communication error (overrun, framing, parity, or CRC-16) is detected in the command message.
3. When the slave address in the command message does not coincide with the address set in the slave.
4. When the time interval of data composing the message exceeds the GPD 506's set 2 second time-out detection period.
5. When the command message data length is not proper.

CRC-16

At the end of the message, the data for CRC error checking is sent in order to detect errors in signal transmission. In Modbus RTU, the error check is conducted in the form of a CRC-16 (Cyclical Redundancy Check). The CRC field checks the contents of the entire message. It is applied regardless of any parity check method used for the individual characters of the message.

The CRC field is two bytes, containing 16-bit binary value. The CRC value is calculated by the transmitting device, which appends the CRC to the message. The receiving device recalculates a CRC during receipt of the message, and compares the calculated value to the actual value it received in the CRC field. If the two values are not equal, an error results.

The CRC is started by first preloading a 16-bit register to all 1's. Then a process begins of applying successive 8-bit bytes of the message to the current contents of the register. Only the eight bits of data in each character are used for generating the CRC. Start and stop bits, and the parity bit (if one is used) do not apply to the CRC.

During generation of the CRC, each 8-bit character is exclusive 'OR'ed with the register contents. Then the result is shifted in the direction of the least significant bit (LSB), with a zero filled into the most significant bit (MSB) position. The LSB is extracted and examined. If the LSB is a 1, the register is then exclusive 'OR'ed with a preset, fixed value (A001h). If the LSB is a 0, no exclusive OR takes place.

This process is repeated until eight shifts have been performed. After the last (eighth) shift, the next 8-bit byte is exclusive 'OR'ed with the register's current value, and the process repeats for eight more shifts as described above. The final content of the register, after all the bytes of the message have been applied, is the CRC value.

For applications using a host computer, a detailed example of a CRC generation using Quick Basic is shown on the following page.

Typical CRC-16 Calculation Program in Quick Basic:

```
crcsum# = &HFFFF&  
crcshift# = &H0&  
crrconst# = &HA001&
```

```
CLS  
PRINT "*****"  
PRINT  
PRINT "          CRC-16 calculator"  
PRINT  
PRINT "*****"  
PRINT "If entering data in hex, precede the data with '&H'"  
PRINT "  Example: 32decimal = 20hex = &H20"  
PRINT "*****"  
PRINT  
  
INPUT "Enter the number of bytes in the message: ", maxbyte  
  
FOR bytenum = 1 TO maxbyte STEP 1  
  PRINT "Enter byte "; bytenum; ":"  
  INPUT byte&  
  byte& = byte& AND &HFF&  
  crcsum# = (crcsum# XOR byte&) AND &HFFFF&  
  FOR shift = 1 TO 8 STEP 1  
    crcshift# = (INT(crcsum# / 2)) AND &H7FFF&  
    IF crcsum# AND &H1& THEN  
      crcsum# = crcshift# XOR crrconst#  
    ELSE  
      crcsum# = crcshift#  
    END IF  
  NEXT shift  
NEXT bytenum  
  
lower& = crcsum# AND &HFF&  
upper& = (INT(crcsum# / 256)) AND &HFF&  
  
PRINT "Lower byte (1st) = ", HEX$(lower&)  
PRINT "Upper byte (2nd) = ", HEX$(upper&)
```

CRC-16 Calculation Example:

A two byte message for a read-out of a specified coil status is as follows.

0000 0010	Slave Address = 2
0000 0111	Function Code = 7

The actual CRC calculation would look like this:

CRCTMP	FLAG	
1111 1111 1111 1111		Initial Value
<u> 0000 0010</u>		Slave Address
1111 1111 1111 1101		Result of EX OR
0111 1111 1111 1110	1	Shift #1
<u>1010 0000 0000 0001</u>		CRC-16 Lower 16
1101 1111 1111 1111		Result of EX OR
0110 1111 1111 1111	1	Shift #2
<u>1010 0000 0000 0001</u>		CRC-16 Lower 16
1100 1111 1111 1110		Result of EX OR
0110 0111 1111 1111	0	Shift #3
0011 0011 1111 1111	1	Shift #4
<u>1010 0000 0000 0001</u>		CRC-16 Lower 16
1001 0011 1111 1110		Result of EX OR
0100 1001 1111 1111	0	Shift #5
0010 0100 1111 1111	1	Shift #6
<u>1010 0000 0000 0001</u>		CRC-16 Lower 16
1000 0100 1111 1110		Result of EX OR
0100 0100 0111 1111	0	Shift #7
0010 0001 0011 1111	1	Shift #8
<u>1010 0000 0000 0001</u>		CRC-16 Lower 16
1000 0001 0011 1110		Result of EX OR
<u> 0000 0111</u>		Function Code
1000 0001 0011 1001		Result of EX OR
0100 0000 1001 1100	1	Shift #1
<u>1010 0000 0000 0001</u>		CRC-16 Lower 16
1110 0000 1001 1101		Result of EX OR
0111 0000 0100 1110	1	Shift #2
<u>1010 0000 0000 0001</u>		CRC-16 Lower 16
1101 0000 0100 1111		Result of EX OR
0110 1000 0010 0111	1	Shift #3
<u>1010 0000 0000 0001</u>		CRC-16 Lower 16
1100 1000 0010 0110		Result of EX OR
0110 0100 0001 0011	0	Shift #4
0011 0010 0000 1001	1	Shift #5
<u>1010 0000 0000 0001</u>		CRC-16 Lower 16
1001 0010 0000 1000		Result of EX OR
0100 1001 0000 0100	0	Shift#6
<u>0010 0100 1000 0010</u>		
<u>0001 0010 0100 0001</u>	0	Shift #8
<u> 1 2 4 1</u>		
CRC-16 (Upper 8)		CRC-16 (Lower 8)

After calculating the CRC-16 upper and lower values they are inserted into the message format as shown below.

0000 0010	Slave Address = 2
0000 0111	Function Code = 7
0100 0001	CRC-16 Lower = 41h
0001 0010	CRC-16 Lower = 12h

Chapter 7

Registers

- Simultaneous Broadcast Registers
- Command Registers
- Monitor Registers
- Drive Parameter Registers
- Special Registers

Simultaneous Broadcast Registers (Write only)

REGISTER (in hex)	FUNCTION	BIT NO.	DATA SET	DESCRIPTION
001	Operational Signals	0	0	Stop
			1	Run
		1	0	Forward Run
			1	Reverse Run
		2		not used
		3		not used
		4	1	External Fault
		5	1	Fault Reset
	6		not used	
	7		not used	
002	Frequency Reference			Reference unit determined by n103 (1)

Notes:

1. Frequency Reference unit (n103) default setting is '0' (0.1Hz / 1).

efesotomasyon.com

Command Registers (Read / Write)

REGISTER (in hex)	FUNCTION	BIT NO.	DATA SET	DESCRIPTION
001	Operational Signals	0	0	Stop
			1	Run
		1	0	Forward Run
			1	Reverse Run
		2	1	External Fault
		3	1	Fault Reset
		4	1	Multi-function Input 1 is selected (closed terminal S3)
		5	1	Multi-function Input 2 is selected (closed terminal S4)
002	Frequency Reference	6	1	Multi-function Input 3 is selected (closed terminal S5)
		7	1	Multi-function Input 4 is selected (closed terminal S6)
				Reference unit determined by n103 (1)
			0	will return zeros
003	Not Supported		0	will return zeros
004	Not Supported		0	will return zeros
005	Not Supported		0	will return zeros
006	Not Supported		0	will return zeros
007	Not Supported		0	will return zeros
008	Not Supported		0	will return zeros
009	Multi-function Contact Output	0	1	Multi-function Output 1 (MA-MC) (2)
		1	1	Multi-function Output 2 (M1-M2) (3)
		2-15		Not Used
00A	Not Supported			will return zeros
00B-01F	Not Supported			will return zeros

Notes:

1. Frequency Reference unit (n103) default setting is '0' (0.1Hz / 1).
2. Effective when n041 = 15.
3. Effective when n042 = 15.

Monitor Registers (Read only)

REGISTER (in hex)	FUNCTION	BIT NO.	DATA SET	DESCRIPTION		
020h	Status Signal	0	0	Stop Command		
			1	Run Command		
		1	0	Forward Command		
			1	Reverse Command		
		2	1	Drive Ready		
		3	1	Drive Faulted		
		4	1	Data Setting Error		
		5	1	Multi-function Output Set 1 (MA-MC)		
		6	1	Multi-function Output Set 2 (M1-M2)		
		7		not used		
		8-15			will return zeros	
		021h	Drive Fault Contents	0	1	Overcurrent (oC), Ground Fault (GF), Load Short Circuit(SC)
				1	1	Overvoltage (uV)
				2	1	Drive Overload (oL2)
				3	1	Drive Overheat (oH1, oH2)
4				not used		
5	1			Main Circuit Fault		
6	1			Braking Transistor Fault (rr), Braking Transistor Overheat Fault (rH)		
7	1			External Fault (EF0, EF2-EF6)		
8	1			Hardware Fault (CFFx)		
9	1			Motor Overload (oL1, oL3)		
10				not used		
11	1			During Undervoltage		
12	1			Power Loss (Uu1, Uu2, Uu3)		
13	1			Input Phase (SPI), Output Phase (SPo)		
14				not used		
15		not used				

Monitor Registers (continued)

REGISTER (in hex)	FUNCTION	BIT NO.	DATA SET	DESCRIPTION
022h	Communication Data Link Status	0	1	Write in Progress
		1		.not used
		2		not used
		3	1	Upper/Lower Fault
		4	1	Consistency Fault
		5		not used
		6		not used
		7		not used
8		not used		
9-15			will return zeros	
023h	Frequency Reference	0-15		units depend on constant n105 (1)
024h	Output Frequency	0-15		units depend on constant n105 (1)
025h	Not Used			will return zeros
026h	Not Used			will return zeros
027h	Output Current	0-15		(1 Amp/10) (2)
028h	Output Motor Voltage	0-15		(1 Volt/1)
029h	Reserved	0-15		
02Ah	Reserved	0-15		
02Bh	External Terminal Input Value	0	1	Input terminal S1 is closed
		1	1	Input terminal S2 is closed
		2	1	Input terminal S3 is closed
		3	1	Input terminal S4 is closed
		4	1	Input terminal S5 is closed
		5	1	Input terminal S6 is closed
		6	1	not used
7	1	not used		

Notes:

1. Frequency Reference unit (n103) default setting is '0' (0.1Hz / 1).
2. Value in register divided by 10 equals actual amps.

Monitor Registers (continued)

REGISTER (in hex)	FUNCTION	BIT NO.	DATA SET	DESCRIPTION
02Ch	Drive Status	0	1	Run Command Received
		1	1	During Zero Speed
		2	1	During Frequency Coincidence
		3	1	Arbitrary Frequency Coincidence
		4	1	Output Frequency \leq n075 (1)
		5	1	Output Frequency \geq n075 (1)
		6	1	Drive Ready
		7	1	Undervoltage Detected
		8	1	During Baseblock
		9	0	Frequency Reference Mode (Communication selected)
			1	Frequency Reference Mode (External Terminals, Digital Operator selected)
		10	0	Run Command Mode (Communication selected)
			1	Run Command Mode (External Terminals, Digital Operator selected)
		11	1	Overtorque Detection
		12	1	Frequency Reference Missing
13		not used		
14	1	Major Fault		
15	1	Communication Error		
02Dh	Multi-function Output Terminal Monitor	0	1	Multi-function Output #1 Status
		1	1	Multi-function Output #2 Status
		2-15		will return zeros
02Eh	Not Used			will return zeros
02Fh	Not Used			will return zeros
030h	Not Used			will return zeros
031h	Main CKT DC Voltage	0-15		(1 Volt/1)
032h-03Ch	Reserved			will return zeros
03Dh	Communication Error	0	1	CRC Error
		1	1	Data Length Error
		2		not used
		3	1	Parity Error
		4	1	Overrun Error
		5	1	Frame Error
		6	1	Time-out Error
7-15			not used	

Monitor Registers (continued)

REGISTER (in hex)	FUNCTION	BIT NO.	DATA SET	DESCRIPTION
032h	Heatsink Temperature			1 C/1
033h	KWh Meter, Lower 4 Digits			n115 ≤ 30 – 0.1 kWh/1
034h	KWh Meter, Upper 4 Digits			n115 > 30 – 1.0 kWh/1
035h	Elapsed Timer, Lower 4 Digits			1 Hr/1
036h	Elapsed Timer, Upper 4 Digits			1 Hr/1
037h	Output Power			0.1 kW/1
038h	PID Feedback			0.1 Hz/1

Notes:

1. Constant n075 is the Desired Frequency Detection Level (settable from 0-400Hz).

Drive Parameter Registers (Read/Write)

REGISTER (in hex)	PARAMETER	PARAMETER FUNCTION	PARAMETER SETTING	LIMITS / DESCRIPTION	INITIAL VALUE				
101h	n001	Parameter Selection / Initialization	0	n001 read & set; n002-n116 read only	1				
			1	n001-n035 read & set; n036-n116 read only					
			2	n001-n053 read & set; n054-n116 read only					
			3	n001-n116 read & set					
			8	initialize for 2-wire control					
			9	initialize for 3-wire control					
			102h	n002		Operation Mode Selection	Run Command		3
							0	Operator	
							1	External Terminals	
2	Operator								
3	External Terminals								
4	Operator								
5	External Terminals								
6	Serial Comm.								
7	Serial Comm.								
8	Serial Comm.								
103h	n003	Input Voltage	150.0-255.0 Volts (230V drive) 150.0-510.0 Volts (460V drive)	230.0 460.0					
104h	n004	Stop Method	0	Ramp to stop	0				
			1	Coast to stop					
			2	Coast to stop (Timer 1)					
			3	Coast to stop (Timer 2)					
105h	n005	Power Rotation	0	Counter clockwise	0				
			1	Clockwise					

Registers

Drive Parameter Registers continued (Read/Write)

REGISTER (in hex)	PARAMETER	PARAMETER FUNCTION	PARAMETER SETTING	LIMITS / DESCRIPTION	INITIAL VALUE
106h	n006	Reverse Prohibit	0 1	Reverse Run Enabled Reverse Run Disabled	0
107h	n007	LOCAL/REMOTE key function	0 1	Disabled Enabled	1
108h	n008	STOP key function	0 1	STOP key enabled when n002 set for Digital Operator STOP key enabled regardless of programming	1
109h	n009	Frequency Reference Setting Method from Digital Operator	0 1	ENTER key does NOT have to be pressed to write in new data values ENTER key does have to be pressed to write in new data values	1
10Ah	n010	V/f Pattern Selection	0 1	Fixed pattern Custom V/f pattern	0
10Bh	n011	Frequency – Max.		50.0 – 400.0 Hz	60.0
10Ch	n012	Voltage – Max. (drive output)		0.1 to 255.0 V (230V drive) 0.1 to 510.0 V (460V drive)	230.0 460.0 (1)
10Dh	n013	Frequency - Max. Voltage Point		0.2 to 400.0 Hz	60.0 (1)
10Eh	n014	Frequency - Midpoint		0.1 to 399.9 Hz	3.0 (1)
10Fh	n015	Voltage - Midpoint		0.1 to 255.0 V (230V drive) 0.1 to 510.0 V (460V drive)	17.2 34.5 (1)
110h	n016	Frequency - Min. (drive output)		0.1 to 10.0 Hz	1.5 (1)
111h	n017	Voltage - Min.		0.1 to 50.0 V (230V drive) 0.1 to 100.0 V (460V drive)	11.5 23.0 (1)

Notes:

1. Initial value differs depending on V/f curve selected (n010 setting). Values shown are initial values when n010 is set to '1'.

Drive Parameter Registers continued (Read/Write)

REGISTER (in hex)	PARAMETER	PARAMETER FUNCTION	PARAMETER SETTING	LIMITS / DESCRIPTION	INITIAL VALUE
112h	n018	Acceleration Time 1		0.0 to 3600 seconds	10.0
113h	n019	Deceleration Time 1		0.0 to 3600 seconds	10.0
114h	n020	Acceleration Time 2		0 to 255 seconds	10.0
115h	n021	Deceleration Time 2		0 to 255 seconds	10.0
116h	n022	S - curve Selection	0	No S - curve	1
			1	0.2 sec	
			2	0.5 sec	
			3	1.0 sec	
117h	n023	Digital Operator Display Mode	0	0.1Hz	0
			1	0.1%	
			2-39	rpm	
			40-4999	custom	
118h	n024	Frequency Reference 1		0.0 to 400.0 Hz (1)	0.0
119h	n025	Frequency Reference 2		0.0 to 400.0 Hz (1)	0.0
11Ah	n026	Frequency Reference 3		0.0 to 400.0 Hz (1)	0.0
11Bh	n027	Frequency Reference 4		0.0 to 400.0 Hz (1)	0.0
11Ch	n028	Frequency Reference 5		0.0 to 400.0 Hz (1)	0.0
11Dh	n029	Frequency Reference 6		0.0 to 400.0 Hz (1)	0.0
11Eh	n030	Jog Reference		0.0 to 400.0 Hz (1)	6.0
11Fh	n031	Frequency Reference – Upper Limit		0 to 109%	100
120h	n032	Frequency Reference – Lower Limit		0 to 100%	0
121h	n033	Motor Rated Current	motor FLA (within 10 to 100% of drive rated current)		(2,3)

Notes:

1. Range and increment may change due to a 'custom' setting of n024.
2. Drive rated current is the 100% level. Setting range is 20 to 200% of the GPD506 rated current.
3. Initial value depends on GPD 506 capacity.

Drive Parameter Registers continued (Read/Write)

REGISTER (in hex)	PARAMETER	PARAMETER FUNCTION	PARAMETER SETTING	LIMITS / DESCRIPTION	INITIAL VALUE
122h	n034	Electronic Thermal Overload Protection (for OL1 fault)	0	No Protection	1
			1	Standard Motor (8 min.)	
			2	Standard Motor (5 min.)	
			3	Blower-cooled Motor (8 min.)	
			4	Blower-cooled Motor (5 min.)	
123h	n035	Overheat Stop Method (for OH1 fault)	0	Ramp to Stop - Decel 1 (fault)	3
			1	Coast to Stop (fault)	
			2	Ramp to Stop - Decel 2 (fault)	
			3	Continue Operation at 80% (alarm)	

Drive Parameter Registers continued (Read/Write)

(Continued from previous page)

124h	n036	Multi-function Input Selection (Terminal S2)	
0		Reverse Run (2-wire sequence)	<div style="display: flex; justify-content: center; align-items: center;"> <div style="margin-right: 10px;">0</div> <div style="text-align: left;">(1; if 3-wire)*</div> </div>
1		Forward/Reverse (3-wire sequence)	
2		External Fault (N.O.)	
3		External Fault (N.C.)	
4		Fault Reset	
5		Remote / Local Selection	
6		Serial Comm/Digital Operator (Freq. Ref. & run/stop command)	
7		Fast Stop Command -Decel 2 (N.O.)	
8		Fast Stop Command -Decel 2 (N.C.)	
9		Auto Frequency Ref. Selection	
10		Multi-step Speed Ref. – Command A	
11		Multi-step Speed Ref. – Command B	
12		Multi-step Speed Ref. – Command C	
13		Jog Command	
14		Accel/Decel Time Change Command	
15		External Base Block (N.O.)	
16		External Base Block (N.C.)	
17		Speed Search from Max. Frequency	
18		Speed Search from Set Frequency	
19		Parameter Change Enable	
20		I Value Reset (PID)	
21		PID Control Off	
22		Timer Function	
23		OH3 (pre-alarm input)	
24		Analog Reference Sample/Hold	
25		Inertia Ridethrough (N.O.)	
26		Inertia Ridethrough (N.C.)	
27		Accel/ Decel Ramp Hold	
28		PID changeover	
29		Up/ Down Command (1)	

Drive Parameter Registers continued (Read/Write)

(Continued from previous page)

REGISTER (in hex)	PARAMETER	PARAMETER FUNCTION	PARAMETER SETTING	LIMITS / DESCRIPTION	INITIAL VALUE
125h	n037	Multi-function Input Selection (Terminal S3)	2-24 same as n036	When n036 is set to '1'; '—' will be displayed & no value may be entered.	2
126h	n038	Multi-function Input Selection (Terminal S4)	2-24 same as n036		4 (2; if 3-wire)*
127h	n039	Multi-function Input Selection (Terminal S5)	2-24 same as n036		9 (4; if 3-wire)*
128h	n040	Multi-function Input Selection (Terminal S6)	2-26 same as n036	When n040 is set to '29'; n039 setting is prohibited	10 (9; if 3-wire)*
129h	n041	Multi-function Output (Terminals MA-MB-MC) (settings 0-17)	0	Fault	
			1	During Running	
			2	Speed Agree	
			3	Desired Speed Agree	0
			4	Frequency Detection 1	
			5	Frequency Detection 2	
			6	Overtorque Detection (N.O.)	
			7	Overtorque Detection (N.C.)	
			8	During Baseblock	
			9	Operation Mode	
			10	Ready	
			11	Timer Function	
			12	During Auto Re-start	1
			13	OL pre-alarm (80% of OL1 or OL2)	
			14	Frequency Reference Loss	
			15	Closed by Serial Communications	
12Ah	n042	Multi-function Output (Terminals M1-M2) (settings 0-17)	16	PID Feedback Loss	

Drive Parameter Registers continued (Read/Write)

(Continued from previous page)

REGISTER (in hex)	PARAMETER	PARAMETER FUNCTION	PARAMETER SETTING	LIMITS / DESCRIPTION	INITIAL VALUE
12Bh	n043	Auto Analog Input Selection	17	OH1 Alarm (only if n035 set to '3')	
			0	FV – Master; FI –Auxiliary Auto/ Manual switch enable - Yes	0
			1	FV – Auxiliary; FI – Master Auto/ Manual switch enable - Yes	
			2	FV – Fault Reset; FI – Master Auto/ Manual switch enable - No	
12Ch	n044	Manual Analog Input Selection (Terminal FI)	0	0-10V input (Jumper J1 must be cut on control PCB)	1
12Dh	n045	Frequency Reference Retention (for Up/Down; Sample/Hold)	0	4-20mA input	
			1	Not Retained	0
12Eh	n046	Frequency Reference Loss Detection	0	Retained in Freq. Reference 1 (n024)	0
			1	No Detection Continue to run at value set in (n047)	0
12Fh	n047	Freq. Ref. Level at loss of Freq. Detection		0-100%	80
130h	n048	Freq. Reference Gain (Term. FV)		0 to 200%	100%
131h	n049	Freq. Reference Bias (Term. FV)		-100% to +100%	0
132h	n050	Freq. Reference Gain (Term. FI)		0 to 200%	100%
133h	n051	Freq. Reference Bias (Term. FI)		-100% to +100%	0
134h	n052	Multi-function Analog Output (Terminals AM & AC)	0	Output Frequency (Hz)	
			1	Output Current (A)	0
			2	Output Power (kW)	
			3	DC Bus Voltage (V DC)	
135h	n053	Analog Monitor Gain		0.01 to 2.00	1.00
136h	n054	Carrier Frequency	1 to 6	x 2.5 kHz	
			7 to 9	asynchronous	(1)

Drive Parameter Registers continued (Read/Write)

(Continued from previous page)

REGISTER (in hex)	PARAMETER	PARAMETER FUNCTION	PARAMETER SETTING	LIMITS / DESCRIPTION	INITIAL VALUE
137h	n055	Momentary Power Loss Ridethrough Method Selection	0	Not Provided	0
			1	Continuous Operation (power recovery within 2 seconds)	
			2	Continuous Operation (after power recovery within control logic time)	
138h	n056	Speed Search Operation Level		0 to 200%	150%
139h	n057	Minimum Base Block Time		0.5 to 5.0 seconds	(1)
13Ah	n058	V/f Reduction Level during Speed Search		0 to 100%	(1)
13Bh	n059	Momentary Power Loss Ridethrough Time		0.0 to 2.0 seconds	(1)
13Ch	n060	No. of Auto. Restart Attempts		0 to 10	0

Notes:

1. Initial Value depends on GPD 506 capacity.

Drive Parameter Registers continued (Read/Write)

REGISTER (in hex)	PARAMETER	PARAMETER FUNCTION	PARAMETER SETTING	LIMITS / DESCRIPTION	INITIAL VALUE
13Dh	n061	Fault Contact Selection at Auto Restart	0	Closed during auto. restart	0
			1	Open during auto. restart	
13Eh	n062	Prohibit Frequency 1		0.0 to 400.0 Hz	0
13Fh	n063	Prohibit Frequency 2		0.0 to 400.0 Hz	0
140h	n064	Prohibit Frequency Deadband		0.0 to 25.5 Hz	1.0
141h	n065	Elapsed Timer Selection	0	Accumulated time during power on	1
			1	Accumulated time during running	
142h	n066	Elapsed Timer 1		0 to 9999 hours	0
143h	n067	Elapsed Timer 2		0 to 27 (x 10,000 hours)	0
144h	n068	DC Injection Current		0 to 100% (100%=drive rated current)	50
145h	n069	DC Injection Time at Stop		0.0 to 10.0 seconds	0.0
146h	n070	DC Injection Time at Start		0.0 to 10.0 seconds	0.0
147h	n071	Torque Compensation Gain		0.0 to 3.0	1.0
148h	n072	Stall Prevention during Decel	0	Disabled	1
			1	Enabled	
149h	n073	Stall Prevention Level during Accel		30 to 200% (@200% disabled during Accel)	(1)
14Ah	n074	Stall Prevention Level at Set Freq.		30 to 200% (@200% disabled during running)	(1)
14Bh	n075	Speed Coincide Frequency		0.0 to 400.0 Hz	0.0
14Ch	n076	Frequency Agreed Detect. Width		0.0 to 25.5 Hz	2.0
14Dh	n077	Overtorque/ Undertorque Detection (OL3)	0	Detection disabled	
			1	Overtorque detect only at set frequency; operation continues	
			2	Overtorque detect during all frequency conditions; operation continues	
			3	Overtorque detect only at set frequency; coast to stop	0

Notes:

1. Initial value depends on GPD 506 capacity.

Drive Parameter Registers continued (Read/Write)

		(Continued from previous page)				
				4	Overtorque detect during all frequency conditions; coast to stop	
				5	Undertorque detect only at a set frequency; operation continues	
				6	Undertorque detect during all frequency conditions; operation continues	
				7	Undertorque detect only at set frequency; coast to stop	
				8	Undertorque detect during all frequency conditions; coast to stop	
14Eh	n078	Overtorque/ Undertorque Det. level		30 to 200%	of drive rated current	160
14Fh	n079	Overtorque/ Undertorque Det. delay time			0.0 to 10.0 seconds	0.1
150h	n080	On-delay Timer			0.0 to 25.5 seconds	0.0
151h	n081	Off-delay Timer			0.0 to 25.5 seconds	0.0
152h	n082	DB Resistor Overheat Function (rH)		0	No DB protection calculated or provided	0
				1	Protection provided for installed MagneTek option DB resistor	
153h	n083	Input Phase Loss Det. Level (SPI)		0 to 100%	(@100% detection is disabled)	7
154h	n084	PID Selection		0	PID disabled	0
				1	PID enabled	
				2	PI with Feed Forward	
				3	PID w/ reversed feedback	
155h	n085	Feedback Calibration			0.00 to 10.00	1.00
156h	n086	Proportional Gain			0.0 to 10.0	1.0
157h	n087	Integral Time			0.0 to 100.0 seconds	10.0
158h	n088	Derivative Time			0.00 to 1.00 seconds	0.00

Drive Parameter Registers continued (Read/Write)

REGISTER (in hex)	PARAMETER	PARAMETER FUNCTION	PARAMETER SETTING	LIMITS / DESCRIPTION	INITIAL VALUE
159h	n089	Limit of Integral Value (PID)		0 to 109%	100
15Ah	n090	Feedback Loss Detection (PID)	0	Detection disabled	0
			1	Detection enabled	
			2	Detection enabled w/ fault condition	
15Bh	n091	Feedback Loss Det. Level (PID)		0 to 100%	0
15Ch	n092	Feedback Loss Det. Delay Time(PID)		0.0 to 25.5 seconds	1.0
15Dh	n093	PID Output Selection	0	Not inverted	0
			1	Inverted	
15Eh	n094	Sleep function start level		0.00 to 400.0 Hz	0.00
15Fh	n095	Sleep function delay time		0.0 to 25.5	0.0
160h	n096	Energy Saving Selection	0	Energy Saving disabled	0
			1	Energy Saving enabled	
161h	n097	Energy Saving Gain (K2)		0.00 to 655.0	(1)
162h	n098	Energy Saving Voltage		0 to 120%	75
		Lower Limit at 60 Hz			
163h	n099	Energy Saving Voltage		0 to 25%	12
		Lower Limit at 6 Hz			
164h	n100	Time of average kW		1 to 250 (1=25ms)	1
165h	n101	Modbus Timeout Detection	0	Time out detection is disabled	1
			1	Time out detection is enabled	
166h	n102	Stop Method on Modbus Communication Error (CE)	0	Ramp to stop-Decel 1 (fault)	1
			1	Coast to stop (fault)	
			2	Ramp to stop-Decel 2 (fault)	
			3	Continue operation (alarm)	

Notes:

1. Initial value depends on GPD 506 capacity.

Drive Parameter Registers continued (Read/Write)

167h	n103	Modbus Frequency Reference Unit	0 1 2 3	0.1 Hz/ 1 0.01 Hz/ 1 100%/ 30000 0.01%/ 1	0
168h	n104	Modbus Slave Address		0 to 31	1
169h	n105	Modbus Baud Rate Selection	0 1 2	2400 bps 4800 bps 9600 bps	2
16Ah	n106	Modbus Parity Selection	0 1 2	No parity Even parity Odd parity	0
16Bh	n107	Slip Compensation Gain		0.0 to 9.9%	0.0
16Ch	n108	No-load motor current		0 to 99%	30
16Dh	n109	Slip Comp. Primary Delay Time Constant		0.0 to 25.5 seconds	2.0
16Eh	n110	Operator Connection Fault Detection Selection	0 1	Cycle Stop Immediate	0
16Fh	n111	Local/ Remote Changeover Fault Detection Selection	0 1	Disabled Enabled	0
170h	n112	Low frequency OL start point		0.0 to 6.0 Hz	6.0
171h	n113	Continuous operation level at 0.0 Hz		25 to 100%	50
172h	n114	Square Root N Monitor Gain		0 to 99	0
173h	n115	KVA selection		00-35	(1)
174h	n116	CT/ VT Selection	0 1	Constant Torque Variable Torque	(1)

Notes:

1. Initial value depends on GPD 506 capacity.

Special Registers (Read / Write)

REGISTER	FUNCTION	DATA SET	DESCRIPTION
900h	Enter Command	0	Writes data into non-volatile memory

Chapter 8

Error Codes and Troubleshooting

- Communication Error (CE)
- Modbus Error Codes
- Figure 8-1. Fault Response Message

Communication Error

Once the data sent from the PLC is received by the drive, the received data is checked for CRC, parity, overrun, framing, and receiving buffer overflow. If all checked items pass, the data has been received normally. A communication error (CE) is declared if any data item cannot be received within 2 seconds.

The GPD 506 drive will operate according to the setting of parameter n102 when a communication error (CE) occurs. The settings of n102 are as follows:

n104 Setting	Description
0	Deceleration (n019) to stop after CE occurs, and the Digital Operator flashes 'CE'.
1	Coast to stop after CE occurs, and the Digital Operator flashes 'CE'.
2	Deceleration (n021) to stop after CE occurs, and the Digital Operator flashes 'CE'.
3	Operation continues after CE occurs, and the Digital Operator flashes 'CE'.

The default setting of n102 is '1'.

Modbus Error Codes

If there is an error in the command message, an error code will be returned in the response message. A fault response message is structured as follows:

SLAVE ADDRESS	xxh	
80h + FUNC. CODE	xxh	
ERROR CODE	03h	
CRC-16	UPPER	xxh
	LOWER	xxh

Figure 8-1. Fault Response Message

The following table indicates the fault code for the specific type of fault that occurred.

Error Code	Name	Fault Content
01h	Function Error	Unregistered Function Code
02h	Register No. Error	Unregistered Register Number
03h	No. of Errors	Number of errors > 16
21h	Write-in Limit Error	Upper/Lower limit exceeded in write-in data
22h	Write-in Error	Write-in is disabled for the register specified

Chapter 9

Command Priority

- Command Priority
- Table 9-1. Set up for Serial Communication Control
- Table 9-2. Set up for External Terminal Control
- Table 9-3. Set up for Digital Operator Control

Command Priority

The setting of parameter n002 determines the origin of frequency reference and operation commands. This was discussed in detail in chapter 5, Setting GPD 506 Parameters for Communication. Some commands may be accessed by a source other than the one set up by parameter n002, as illustrated in the tables 1, 2, and 3 on the following pages.

How to use the Command Priority Tables:

First, determine the source of control you wish to use for your GPD506 drive. Then the n002 parameter should be set up for the desired control you have chosen. (See the table below for parameter settings.) Select the appropriate Command Priority table on the following pages based upon what type of operation your drive is set up for.

n002 Setting	Operation Command Reference	Frequency Reference	Use Table:
0	Digital Operator	Digital Operator	9-3
1	External Terminals	Digital Operator	9-2
2	Digital Operator	External Terminals	9-3
3	External Terminals	External Terminals	9-2
4	Digital Operator	Serial Communication	9-3
5	External Terminals	Serial Communication	9-2
6	Serial Communication	Serial Communication	9-1
7	Serial Communication	Digital Operator	9-1
8	Serial Communication	External Terminals	9-1

The left hand column of the Command Priority tables is the source of the operation command (serial communication, external terminals, and the Digital Operator). The middle column lists the functions or commands, and the right most column indicates whether the functions are operational or not available from each source.

Table 9-1: Set up for Serial Communication Control

The first table indicates the functions or commands that can be accessed via serial communication, external terminals, or the digital operator when drive parameter n002 is set up for serial communication (n002 = 6, 7, or 8). The 'O' indicates that the function is Operable from that source, and 'n/a' indicates that the function is not available from that source.

From	Data Code	Bit No.	Data Description	Function Availability
SERIAL COMM.	001h	0	Run Command	O
		1	Forward / Reverse	O
		2	External Fault	O
		3	Fault Reset	O (1)
		4	Multi-function Input (terminal S3)	O
		5	Multi-function Input (terminal S4)	O
		6	Multi-function Input (terminal S5)	O
		7	Multi-function Input (terminal S6)	O
	8-15	unused	-	
	003h-008h		unused	-
	009h	0	Multi-function Output 1 (MA - MC)	O (2)
		1	Multi-function Output 2 (M1 - M2)	O (3)
		2	unused	
3-7		unused	-	
EXTERNAL TERMINALS	Forward Run (2 wire); Run Command (3 wire)			n/a
	Reverse Run (2 wire); Stop Command (3 wire)			n/a
	Multi-function input terminal S2			(4)
	Multi-function input terminal S3			(4)
	Multi-function input terminal S4			(4)
	Multi-function input terminal S5			(4)
	Multi-function input terminal S6			(4)
DIGITAL OPERATOR	Run Command			n/a
	Stop Command			O (5)
	Fault Reset			O (1)
	Local / Remote			O (1,6)

Notes:

1. Effective when run command received from PLC is '0' while in stopped condition.
2. Effective when n041 is '15'.
3. Effective when n042 is '15'.
4. The availability of the multi-function input terminals vary depending upon the settings of n036, n037, n038, n039, and n040 (the multi-function input settings). See technical manual TM 4506.
5. Effective only when n008 is '1'.
6. Effective only when n007 is '1'.

Table 9-2: Set up for External Terminals Control

Table two indicates the functions or commands that can be accessed via serial communication, external terminals, or the digital operator when drive parameter n002 is set up for external terminal control (n002 = 1,3, or 5). The 'O' indicates that the function is Operable from that source, and 'n/a' indicates that the function is not available from that source.

From	Data Code	Bit No.	Data Description	Function Availability
SERIAL COMM.	001h	0	Run Command	n/a
		1	Forward / Reverse	n/a
		2	External Fault	O
		3	Fault Reset	O (1)
		4	Multi-function Input (terminal S3)	O
		5	Multi-function Input (terminal S4)	O
		6	Multi-function Input (terminal S5)	O
		7	Multi-function Input (terminal S6)	O
	8-15	unused	-	
	003h-008h		unused	-
	009h	0	Multi-function Output 1 (MA - MC)	O (6)
		1	Multi-function Output 2 (M1 - M2)	O (7)
		2	unused	-
3-7		unused	-	
EXTERNAL TERMINALS	Forward Run (2 wire); Run Command (3 wire)			O
	Reverse Run (2 wire); Stop Command (3 wire)			O
	Multi-function input terminal S2			(5)
	Multi-function input terminal S3			(5)
	Multi-function input terminal S4			(5)
	Multi-function input terminal S5			(5)
	Multi-function input terminal S6			(5)
DIGITAL OPERATOR	Run Command			n/a
	Stop Command			O (3)
	Fault Reset			O (1)
	Local / Remote			O (1,4)

Notes:

- Effective only when external terminal satisfies the following conditions:
 - 2 wire mode* - Both forward run (term.1) and reverse run (term.2) commands are closed, or open in stopped condition.
 - 3 wire mode* - Run command (term.1) or stop command (term.2) is open in stopped condition.
- Effective only when in stopped condition.
- Effective only when n008 is '1'.
- Effective only when n007 is '1'.
- The availability of the multi-function input terminals vary depending upon the settings of n036, n037, n038, n039 (the multi-function input settings), and n040. See technical manual TM 4506.
- Effective when n041 is '15'.
- Effective when n042 is '15'.

Table 9-3: Set up for Digital Operator Control

Table three indicates the functions or commands that can be accessed via serial communication, external terminals, or the digital operator when drive parameter n002 is set up for digital operator control (n002 = 0, 2, or 4). The 'O' indicates that the function is Operable from that source, and 'n/a' indicates that the function is not available from that source.

From	Data Code	Bit No.	Data Description	Function Availability
SERIAL COMM.	001h	0	Run Command	n/a
		1	Forward / Reverse	n/a
		2	External Fault	O
		3	Fault Reset	O (1)
		4	Multi-function Input (terminal S3)	O
		5	Multi-function Input (terminal S4)	O
		6	Multi-function Input (terminal S5)	O
		7	Multi-function Input (terminal S6)	O
	8-15	unused	-	
	003h-008h		unused	-
	009h	0	Multi-function Output 1 (MA - MC)	O (3)
		1	Multi-function Output 2 (M1 - M2)	O (4)
		2	unused	-
		3-7	unused	-
EXTERNAL TERMINALS	Forward Run (2 wire); Run Command (3 wire)			n/a
	Reverse Run (2 wire); Stop Command (3 wire)			n/a
	Multi-function input terminal S2			(2)
	Multi-function input terminal S3			(2)
	Multi-function input terminal S4			(2)
	Multi-function input terminal S5			(2)
	Multi-function input terminal S6			(2)
DIGITAL OPERATOR	Run Command			O
	Stop Command			O
	Fault Reset			O (1)
	Local / Remote			n/a

- Notes:
- Effective only when in stopped condition.
- The availability of the multi-function input terminals vary depending upon the settings of n036, n037, n038, n039, and n040 (the multi-function input settings). See technical manual TM 4506.
- Effective when n041 is '15'.
- Effective when n042 is '15'.

Appendix A

Product Specifications

The following table indicates the environmental specifications for the CM086 Board.

(CM086) RS-232 to RS-485 Converter Board for GPD 506	
Ambient Temperature	-10 to +40 degrees C (+14 to +104 degrees F)
Storage Temperature	-20 to +60 degrees C (-4 to +140 degrees F)
Relative Humidity	90% non-condensing
Altitude	3300 feet
Vibration	1G at less than 20 Hz, 0.2 G at 20 - 50 Hz

Notes:

Appendix B

Spare Parts List

Description	Source	Part Number
GPD 506 / Modbus RTU		
RS-232 to RS-485 Converter Board	Yaskawa	CM086
RS-232 Connector Kit for 2CN	Yaskawa	CM088
GPD 506 / Modbus RTU Technical Manual	Yaskawa	TM 4026
Miscellaneous		
GPD 506 Technical Manual	Yaskawa	TM 4506

Notes:

Appendix C

RS232-C/D Connections

RS232-C DTE (Male) Connector				RS232-C DCE (Female) Connector					
Protective Ground	1	●	14	Secondary TD	Secondary TD	14	○	1	Protective Ground
Transmit Data	2	●	15	Transmitter Signal Element Timing	Transmitter Signal Element Timing	15	○	2	Transmit Data
Receive Data	3	●	16	Secondary RD	Secondary RD	16	○	3	Receive Data
Request to Send	4	●	17	Receiver Signal Element Timing	Receiver Signal Element Timing	17	○	4	Request to Send
Clear to Send	5	●	18	Unassigned	Unassigned	18	○	5	Clear to Send
Data St Ready	6	●	19	Secondary RTS	Secondary RTS	19	○	6	Data St Ready
Signal Ground	7	●	20	Data Terminal Ready	Data Terminal Ready	20	○	7	Signal Ground
Carrier Detect	8	●	21	Signal Quality Detector	Signal Quality Detector	21	○	8	Carrier Detect
Reserved	9	●	22	Ring Indicator	Ring Indicator	22	○	9	Reserved
Reserved	10	●	23	Data Signal Rate Selector	Data Signal Rate Selector	23	○	10	Reserved
Unassigned	11	●	24	Transmit signal element Timing	Transmit signal element Timing	24	○	11	Unassigned
Secondary CD	12	●	25	Unassigned	Unassigned	25	○	12	Secondary CD
Secondary CTS	13	●					○	13	Secondary CTS

RS232-C (25 pin D-Shell)

RS232-D DTE (Male) Connector				RS232-D DCE (Female) Connector					
Carrier Detect	1	●	6	Data Set Ready	Data Set Ready	6	○	1	Carrier Detect
Receive Data	2	●	7	Request to Send	Request to Send	7	○	2	Receive Data
Transmit Data	3	●	8	Clear to Send	Clear to Send	8	○	3	Transmit Data
Data Terminal Ready	4	●	9	Ring Indicator	Ring Indicator	9	○	4	Data Terminal Ready
Signal Ground	5	●					○	5	Signal Ground

RS232-D (9 pin D-Shell)

Note: RS232-D differs from RS232-C in connector type and pinout only.

GPD 506/P5 ModbusRTU

Yaskawa technical support is available to provide telephone assistance for **installation, programming, & troubleshooting** of Yaskawa drives. All support is available during normal business hours. Emergency breakdown support is available on a 24 hour / 7 day basis.

Help us help you. When you call, please have the following information available.

- Have this manual at hand. The support associate will refer to it.
- Drive model and all nameplate data.
- Motor type, brand, and all nameplate data.

For Troubleshooting, additional information may be required.

- Power distribution information (type – delta, wye; power factor correction; other major switching devices used; voltage fluctuations)
- Installation wiring (separation of power & control wire; wire type/class used; distance between drive and motor, grounding.
- Use of any devices between the drive & motor (output chokes, etc.).

Please phone us at: 1-800-YASKAWA (927-5292) for technical support.

Additional technical information is available at www.yaskawa.com.



Data subject to change without notice. NCL, GPD, and VCD are trademarks of Yaskawa, Inc.
Modicon, ModConnect, Modbus, Modbus Plus and 984 are trademarks of Modicon, Inc.



Yaskawa America, Inc.
2121 Norman Drive South, Waukegan, IL 60084, U.S.A.
Phone: 1-847-887-7000 or (800) YASKAWA (927-5292)
Internet: <http://www.yaskawa.com>