

# Test Solutions - Programming Manual

## Programmable Attenuators



- RC8DAT Series** USB & Ethernet 8-Channel Attenuators
- RC4DAT Series** USB & Ethernet 4-Channel Attenuators
- RCDAT Series** USB & Ethernet Programmable Attenuators
- RUDAT Series** USB & RS232 Programmable Attenuators
- ZVVA Series** USB & RS232 Programmable Attenuators

**Mini-Circuits®**

PO Box 350166, Brooklyn, NY 11235-0003  
+1 718-934-4500 | testsolutions@minicircuits.com  
[www.minicircuits.com](http://www.minicircuits.com)

## **Important Notice**

This guide is owned by Mini-Circuits and is protected by copyright, trademark and other intellectual property laws.

The information in this guide is provided by Mini-Circuits as an accommodation to our customers and may be used only to promote and accompany the purchase of Mini-Circuits' Parts. This guide may not be reproduced, modified, distributed, published, stored in an electronic database, or transmitted and the information contained herein may not be exploited in any form or by any means, electronic, mechanical recording or otherwise, without prior written permission from Mini-Circuits.

This guide is subject to change, qualifications, variations, adjustments or modifications without notice and may contain errors, omissions, inaccuracies, mistakes or deficiencies. Mini-Circuits assumes no responsibility for, and will have no liability on account of, any of the foregoing. Accordingly, this guide should be used as a guideline only.

## **Trademarks**

Microsoft, Windows, Visual Basic, Visual C# and Visual C++ are registered trademarks of Microsoft Corporation. LabVIEW and CVI are registered trademarks of National Instruments Corporation. Delphi is a registered trademark of Delphi Technologies, Inc. MATLAB is a registered trademark of The MathWorks, Inc. Agilent VEE is a registered trademark of Agilent Technologies, Inc. Linux is a registered trademark of Linus Torvalds. Mac is a registered trademark of Apple Inc. Python is a registered trademark of Python Software Foundation Corporation.

All other trademarks cited within this guide are the property of their respective owners. Neither Mini-Circuits nor the Mini-Circuits PTE (portable test equipment) series are affiliated with or endorsed or sponsored by the owners of the above referenced trademarks.

Mini-Circuits and the Mini-Circuits logo are registered trademarks of Scientific Components Corporation.

## **Mini-Circuits**

13 Neptune Avenue

Brooklyn, NY 11235, USA

Phone: +1-718-934-4500

Email: [testsolutions@minicircuits.com](mailto:testsolutions@minicircuits.com)

Web: [www.minicircuits.com](http://www.minicircuits.com)

<b>1 - Overview .....</b>	<b>8</b>
<b>1.1 - Control Methods .....</b>	<b>8</b>
<b>2 - SCPI Commands for Programmable Attenuator Control .....</b>	<b>9</b>
<b>2.1 - Cascading Multiple Attenuators for Daisy-Chain Control .....</b>	<b>9</b>
<b>2.2 - SCPI - General Commands .....</b>	<b>11</b>
2.2 (a) - Get Model Name .....	11
2.2 (b) - Get Serial Number .....	12
2.2 (c) - Set Start-Up Attenuation Mode .....	13
2.2 (d) - Get Start-Up Attenuation Mode .....	14
2.2 (e) - Store Last Attenuation Value .....	15
2.2 (f) - Set USB Address .....	16
2.2 (g) - Get USB Address .....	17
2.2 (h) - Get Firmware Version .....	18
<b>2.3 - SCPI - ZVVA / RUDAT / RCDAT (Single Channel) Attenuation Functions .....</b>	<b>19</b>
2.3 (a) - Set Attenuation .....	19
2.3 (b) - Read Attenuation .....	20
2.3 (c) - Set Start-Up Attenuation Value .....	21
2.3 (d) - Get Start-Up Attenuation Value .....	22
2.3 (e) - Set Attenuation Mode (RCDAT-40G-30) .....	23
2.3 (f) - Query Attenuation Mode (RCDAT-40G-30) .....	24
<b>2.4 - SCPI - RC4DAT &amp; RC8DAT (Multi-Channel) Attenuation Functions .....</b>	<b>25</b>
2.4 (a) - Set Attenuation .....	26
2.4 (b) - Set Attenuation Per Channel .....	27
2.4 (c) - Read Attenuation .....	28
2.4 (d) - Set Channel Start-Up Attenuation Value .....	29
2.4 (e) - Get Channel Start-Up Attenuation Value .....	30
<b>2.5 - SCPI - Daisy-Chain Options .....</b>	<b>31</b>
2.5 (a) - Assign Addresses .....	31
2.5 (b) - Count Number of Slaves .....	32
<b>2.6 - SCPI - Attenuation Hopping Commands .....</b>	<b>33</b>
2.6 (a) - Hop Mode - Set Number of Points .....	35
2.6 (b) - Hop Mode - Get Number of Points .....	36
2.6 (c) - Hop Mode - Set Active Channels .....	37
2.6 (d) - Hop Mode - Get Active Channels .....	38
2.6 (e) - Hop Mode - Set Sequence Direction .....	39
2.6 (f) - Hop Mode - Get Sequence Direction .....	40
2.6 (g) - Hop Mode - Set Indexed Point .....	41
2.6 (h) - Hop Mode - Get Indexed Point .....	42
2.6 (i) - Hop Mode - Set Point Dwell Time Units .....	43
2.6 (j) - Hop Mode - Set Point Dwell Time .....	44
2.6 (k) - Hop Mode - Get Point Dwell Time .....	45
2.6 (l) - Hop Mode - Set Point Attenuation .....	46
2.6 (m) - Hop Mode - Set Channel Point Attenuation .....	47
2.6 (n) - Hop Mode - Get Point Attenuation .....	48
2.6 (o) - Hop Mode - Get Channel Point Attenuation .....	49
2.6 (p) - Hop Mode - Turn On / Off .....	50
<b>2.7 - SCPI - Attenuation Sweeping / Fading Commands .....</b>	<b>51</b>
2.7 (a) - Sweep Mode - Set Sweep Direction .....	53
2.7 (b) - Sweep Mode - Get Sweep Direction .....	54
2.7 (c) - Sweep Mode - Set Dwell Time Units .....	55
2.7 (d) - Sweep Mode - Set Dwell Time .....	56

2.7 (e) - Sweep Mode - Get Dwell Time .....	57
2.7 (f) - Sweep Mode - Set Active Channels .....	58
2.7 (g) - Sweep Mode - Get Active Channels.....	59
2.7 (h) - Sweep Mode - Set Start Attenuation.....	60
2.7 (i) - Sweep Mode - Set Channel Start Attenuation.....	61
2.7 (j) - Sweep Mode - Get Start Attenuation .....	62
2.7 (k) - Sweep Mode - Get Channel Start Attenuation .....	63
2.7 (l) - Sweep Mode - Set Stop Attenuation .....	64
2.7 (m) - Sweep Mode - Set Channel Stop Attenuation .....	65
2.7 (n) - Sweep Mode - Get Stop Attenuation.....	66
2.7 (o) - Sweep Mode - Get Channel Stop Attenuation .....	67
2.7 (p) - Sweep Mode - Set Step Size.....	68
2.7 (q) - Sweep Mode - Set Channel Step Size .....	69
2.7 (r) - Sweep Mode - Get Step Size.....	70
2.7 (s) - Sweep Mode - Get Channel Step Size .....	71
2.7 (t) - Sweep Mode - Turn On / Off .....	72
<b>2.8 - SCPI - Ethernet Configuration Commands .....</b>	<b>73</b>
2.8 (a) - Set Static IP Address.....	74
2.8 (b) - Get Static IP Address.....	75
2.8 (c) - Set Static Subnet Mask.....	76
2.8 (d) - Get Static Subnet Mask.....	77
2.8 (e) - Set Static Network Gateway .....	78
2.8 (f) - Get Static Network Gateway .....	79
2.8 (g) - Set HTTP Port .....	80
2.8 (h) - Get HTTP Port .....	81
2.8 (i) - Set Telnet Port .....	82
2.8 (j) - Get Telnet Port.....	83
2.8 (k) - Enable Custom Telnet Prompt .....	84
2.8 (l) - Query Telnet Prompt Type.....	85
2.8 (m) - Set Custom Telnet Prompt Text.....	86
2.8 (n) - Get Custom Telnet Prompt Text .....	87
2.8 (o) - Set Password Requirement.....	88
2.8 (p) - Get Password Requirement.....	89
2.8 (q) - Set Password.....	90
2.8 (r) - Get Password.....	91
2.8 (s) - Set DHCP Status.....	92
2.8 (t) - Get DHCP Status .....	93
2.8 (u) - Get MAC Address.....	94
2.8 (v) - Get Current Ethernet Configuration .....	95
2.8 (w) - Enable / Disable Ethernet Interface.....	96
2.8 (x) - Check Ethernet Interface .....	97
2.8 (y) - Update Ethernet Settings.....	98
<b>3 - Ethernet Control API.....</b>	<b>99</b>
3.1 - Configuring Ethernet Settings .....	99
3.2 - HTTP Communication .....	100
3.3 - SSH Communication .....	100
3.4 - Telnet Communication .....	101
3.5 - Device Discovery Using UDP .....	102
<b>4 - USB Control API for Microsoft Windows .....</b>	<b>103</b>
4.1 - DLL API Options.....	103
4.1 (a) - .NET Framework 4.5 DLL (Recommended) .....	103

4.1 (b) - .NET Framework 2.0 DLL (Legacy Support).....	103
4.1 (c) - ActiveX COM Object DLL (Legacy Support) .....	104
<b>4.2 - Referencing the DLL.....</b>	<b>106</b>
<b>4.3 - Note on DLL Use in Python / MatLab .....</b>	<b>107</b>
<b>4.4 - DLL Function Definitions.....</b>	<b>108</b>
4.4 (a) - DLL Functions for USB Control.....	108
4.4 (b) - DLL Functions for ZVVA / RUDAT / RCDAT (Single Channel) Models.....	108
4.4 (c) - DLL Functions for RC4DAT & RC8DAT (Multi-Channel) Models.....	108
4.4 (d) - DLL Functions for Ethernet Configuration .....	109
4.4 (e) - DLL Functions for Attenuation Hopping .....	110
4.4 (f) - DLL Functions for Attenuation Sweeping / Fading .....	110
<b>4.5 - DLL Function Explanations - USB Control.....</b>	<b>111</b>
4.5 (a) - Get List of Connected Serial Numbers .....	111
4.5 (b) - Get List of Available Addresses.....	112
4.5 (c) - Connect to Attenuator .....	113
4.5 (d) - Connect to Attenuator by Address .....	114
4.5 (e) - Disconnect from Attenuator .....	115
4.5 (f) - Read Model Name .....	116
4.5 (g) - Read Serial Number .....	117
4.5 (h) - Set USB Address.....	118
4.5 (i) - Get USB Address .....	119
4.5 (j) - Set Start-Up Attenuation Mode.....	120
4.5 (k) - Get Start-Up Attenuation Mode .....	121
4.5 (l) - Store Last Attenuation Value .....	122
4.5 (m) - Send SCPI Command.....	123
4.5 (n) - Get USB Connection Status.....	124
4.5 (o) - Get Status (Antiquated) .....	125
4.5 (p) - Get Firmware .....	126
<b>4.6 - DLL Function Explanations - ZVVA / RUDAT / RCDAT (Single Channel) Models.....</b>	<b>127</b>
4.6 (a) - Set Attenuation .....	127
4.6 (b) - Read Attenuation.....	128
4.6 (c) - Set Start-Up Attenuation Value.....	129
4.6 (d) - Get Start-Up Attenuation Value .....	130
<b>4.7 - DLL - RC4DAT (Multi-Channel) Attenuation Functions .....</b>	<b>131</b>
4.7 (a) - Set Attenuation - Single Channel .....	131
4.7 (b) - Set Attenuation - All Channels Same Value .....	132
4.7 (c) - Get Attenuation Value - Single Channel.....	133
4.7 (d) - Get Attenuation Value - All Channels .....	134
4.7 (e) - Set Channel Start-Up Attenuation Value .....	135
4.7 (f) - Get Channel Start-Up Attenuation Value .....	136
<b>4.8 - DLL Function Explanations - Ethernet Configuration.....</b>	<b>137</b>
4.8 (a) - Get Ethernet Configuration.....	137
4.8 (b) - Get IP Address.....	139
4.8 (c) - Get MAC Address .....	141
4.8 (d) - Get Network Gateway .....	143
4.8 (e) - Get Subnet Mask.....	145
4.8 (f) - Get TCP/IP Port .....	147
4.8 (g) - Get Telnet Port.....	148
4.8 (h) - Query Telnet Prompt Type .....	149
4.8 (i) - Get Custom Telnet Prompt Text .....	150
4.8 (j) - Get DHCP Status.....	151
4.8 (k) - Get Password Status .....	152

4.8 (l) - Get Password .....	153
4.8 (m) - Save IP Address.....	154
4.8 (n) - Save Network Gateway.....	155
4.8 (o) - Save Subnet Mask.....	156
4.8 (p) - Save TCP/IP Port .....	157
4.8 (q) - Save Telnet Port.....	158
4.8 (r) - Enable Custom Telnet Prompt.....	159
4.8 (s) - Set Custom Telnet Prompt Text .....	160
4.8 (t) - Use DHCP.....	161
4.8 (u) - Use Password.....	162
4.8 (v) - Set Password .....	163
4.8 (w) - Enable / Disable Ethernet Interface.....	164
4.8 (x) - Check Ethernet Interface .....	165
<b>4.9 - DLL Function Explanations - Attenuation Hopping.....</b>	<b>166</b>
4.9 (a) - Hop Mode - Set Number of Points.....	167
4.9 (b) - Hop Mode - Get Number of Points.....	168
4.9 (c) - Hop Mode - Get Maximum Number of Points.....	169
4.9 (d) - Hop Mode - Set Sequence Direction.....	170
4.9 (e) - Hop Mode - Get Sequence Direction .....	171
4.9 (f) - Hop Mode - Get Maximum Dwell Time.....	172
4.9 (g) - Hop Mode - Get Minimum Dwell Time.....	173
4.9 (h) - Hop Mode - Single Channel - Set Hop.....	174
4.9 (i) - Hop Mode - Single Channel - Get Hop.....	175
4.9 (j) - Hop Mode - Multi-Channel - Set Active Channels .....	176
4.9 (k) - Hop Mode - Multi-Channel - Get Active Channels.....	177
4.9 (l) - Hop Mode - Multi-Channel Hop - Set Hop Point for All Channels .....	178
4.9 (m) - Hop Mode - Multi-Channel - Get Hop Point for All Channels.....	179
4.9 (n) - Hop Mode - Turn On / Off.....	181
<b>4.10 - DLL Function Explanations - Attenuation Sweeping / Fading .....</b>	<b>183</b>
4.10 (a) - Sweep Mode - Set Sweep Direction.....	184
4.10 (b) - Sweep Mode - Get Sweep Direction.....	185
4.10 (c) - Sweep Mode - Set Dwell Time .....	186
4.10 (d) - Sweep Mode - Get Dwell Time .....	187
4.10 (e) - Sweep Mode - Get Maximum Dwell Time .....	189
4.10 (f) - Sweep Mode - Get Minimum Dwell Time .....	190
4.10 (g) - Sweep Mode - Single Channel - Set Start Attenuation .....	191
4.10 (h) - Sweep Mode - Single Channel - Get Start Attenuation .....	192
4.10 (i) - Sweep Mode - Single Channel - Set Stop Attenuation.....	193
4.10 (j) - Sweep Mode - Single Channel - Get Stop Attenuation .....	194
4.10 (k) - Sweep Mode - Single Channel - Set Step Size .....	195
4.10 (l) - Sweep Mode - Single Channel - Get Step Size .....	196
4.10 (m) - Sweep Mode - Multi-Channel - Set Active Channels.....	197
4.10 (n) - Sweep Mode - Multi-Channel - Get Active Channels .....	198
4.10 (o) - Sweep Mode - Multi-Channel - Set Channel Start Attenuation.....	199
4.10 (p) - Sweep Mode - Multi-Channel - Get Channel Start Attenuation.....	200
4.10 (q) - Sweep Mode - Multi-Channel - Set Channel Stop Attenuation .....	201
4.10 (r) - Sweep Mode - Multi-Channel - Get Channel Stop Attenuation .....	202
4.10 (s) - Sweep Mode - Multi-Channel - Set Channel Step Size .....	203
4.10 (t) - Sweep Mode - Multi-Channel - Get Channel Step Size .....	204
4.10 (u) - Sweep Mode - Turn On / Off .....	205
<b>5 - USB Control via Direct Programming (Linux) .....</b>	<b>207</b>
5.1 (a) - USB Interrupt Code Concept.....	207

<b>5.2 - Interrupts - General Commands.....</b>	<b>207</b>
5.2 (a) - Get Device Model Name .....	208
5.2 (b) - Get Device Serial Number.....	209
5.2 (c) - Send SCPI Command .....	210
5.2 (d) - Get Firmware .....	212
5.2 (e) - Set Attenuation.....	213
5.2 (f) - Read Attenuation.....	214
<b>5.3 - Interrupts - Ethernet Configuration Commands .....</b>	<b>216</b>
5.3 (a) - Set Static IP Address.....	217
5.3 (b) - Set Static Subnet Mask .....	218
5.3 (c) - Set Static Network Gateway .....	219
5.3 (d) - Set HTTP Port .....	220
5.3 (e) - Set Telnet Port .....	221
5.3 (f) - Enable Custom Telnet Prompt.....	222
5.3 (g) - Set Custom Telnet Prompt Text.....	223
5.3 (h) - Use Password.....	224
5.3 (i) - Set Password.....	225
5.3 (j) - Use DHCP .....	226
5.3 (k) - Get Static IP Address.....	227
5.3 (l) - Get Static Subnet Mask.....	228
5.3 (m) - Get Static Network Gateway .....	229
5.3 (n) - Get HTTP Port .....	230
5.3 (o) - Get Telnet Port.....	231
5.3 (p) - Query Telnet Prompt Type .....	232
5.3 (q) - Get Custom Telnet Prompt Text .....	233
5.3 (r) - Get Password Status.....	234
5.3 (s) - Get Password.....	235
5.3 (t) - Get DHCP Status .....	236
5.3 (u) - Get Dynamic Ethernet Configuration .....	237
5.3 (v) - Get MAC Address .....	239
5.3 (w) - Reset Ethernet Configuration .....	240
<b>6 - Serial Control Using RS232 Communication .....</b>	<b>241</b>
<b>6.1 - Summary of ASCII Commands.....</b>	<b>241</b>
<b>6.2 - Description of ASCII Commands.....</b>	<b>242</b>
6.2 (a) - Get Device Model Name .....	242
6.2 (b) - Get Device Serial Number.....	243
6.2 (c) - Set Attenuation .....	244
6.2 (d) - Read Attenuation (Integer).....	245
6.2 (e) - Read Attenuation (Decimal) .....	246
6.2 (f) - Send SCPI Command.....	247

## 1 - Overview

This Programming Manual is intended for customers wishing to create their own interface for Mini-Circuits' USB and Ethernet controlled, programmable attenuators. The contents apply to:

- ZVVA Series (USB & RS232 controlled) variable attenuators
- RUDAT Series (USB & RS232 controlled) single channel attenuators
- RCDAT Series (USB & Ethernet controlled) single channel attenuators
- RC4DAT & RC8DAT Series (USB & Ethernet controlled) 4 & 8-channel attenuators

The full software and documentation package including a GUI program, DLL files, user guide and programming examples is available for download from the Mini-Circuits website at:

<https://www.minicircuits.com/softwaredownload/patt.html>

For details and specifications of individual models please see:

<https://www.minicircuits.com/WebStore/RF-Programmable-Step-Attenuators.html>

Files made available for download from the Mini-Circuits website are subject to Mini-Circuits' terms of use which are available on the website.

### 1.1 - Control Methods

Communication with the device can use any of the following approaches:

1. For Ethernet connected models, using HTTP or Telnet communication over an Ethernet TCP / IP connection (see [Ethernet Control API](#)), which is largely independent of the operating system.  
Note: SSH communication is not supported as standard on all models. Please contact [testsolutions@minicircuits.com](mailto:testsolutions@minicircuits.com) for details.
2. Using the provided API files (ActiveX or .Net objects) for USB control on Microsoft Windows operating systems (see [USB Control API for Microsoft Windows](#))
3. Using USB interrupt codes for direct programming on Linux operating systems (see [USB Control via Direct Programming \(Linux\)](#))
4. For RS232 connected models, using serial communication (see [Serial Control Using RS232 Communication](#))

In all cases the full functionality of the system is accessible using a command set based on SCPI (see [SCPI Commands for Programmable Attenuator Control](#)).

## 2 - SCPI Commands for Programmable Attenuator Control

The recommended method for setting states and querying the system is a series of commands based on SCPI (Standard Commands for Programmable Instruments). These commands can be sent using any of the APIs detailed in this manual.

The SCPI commands / queries are case insensitive and sent as an ASCII text string (up to 63 characters). The response from the system is also in the form of an ASCII text string.

### 2.1 - Cascading Multiple Attenuators for Daisy-Chain Control

Mini-Circuits' RCDAT-30G-30, RCDAT-40G-30 and RC4DAT-8G-120H programmable attenuators include Mini-Circuits' novel daisy-chain control interface with dynamic addressing. This allows multiple attenuators to be connected into a Master / Slave chain via their respective Serial Out and Serial In control connections. All attenuators in the chain can then be controlled via the USB or Ethernet interface of the Master (the first attenuator in the chain).

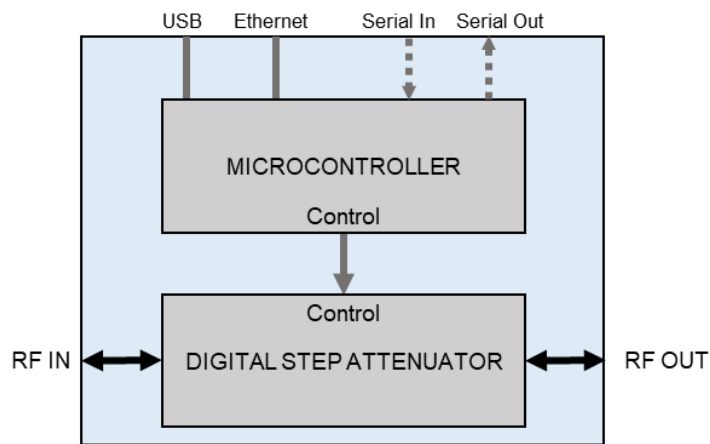

RCDAT-30G-30 block diagram showing all RF and control connections

Each attenuator in the chain is dynamically assigned an address when the control connection (USB or Ethernet) is established with the Master. The Master address is always 00, with each subsequent Slave in the chain assigned a 2 digit address in sequence from 01 to  $nn$ .

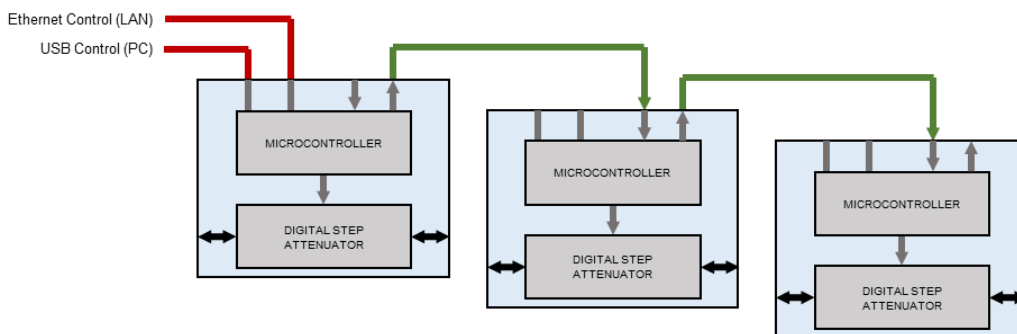

Connection diagram showing 3 x RCDAT-30G-30 attenuators connected into a Master / Slave chain

If new attenuators are subsequently added to the daisy-chain, or the order is changed, then the following commands can be issued to refresh the addresses and check the number of connected attenuators. See [SCPI - Daisy-Chain Options](#) for full details.

`:AssignAddresses` Re-assign the addresses for the complete daisy-chain, starting from the 00 for the Master  
`:NumberOfSlaves` Check the number of slave devices connected in the daisy-chain

The full list of SCPI control commands / queries for identifying and controlling the attenuators are summarised in the following sections. These commands can be directed to any Slave unit by including the 2 digit address at the beginning of the string in the format shown below. Any commands sent without an address component will be directed to the Master (address 00).

`:[address]:COMMAND`

For example:

`:MN?` Return the model name of the Master attenuator (address 00)  
`:00:MN?` Return the model name of the Master attenuator (address 00)  
`:01:MN?` Return the model name of the first Slave attenuator (address 01)  
`:02:MN?` Return the model name of the second Slave attenuator (address 02)

As the DC supply to the Slave attenuators can also be passed along the daisy-chain it is beneficial to reduce the current consumption of the Slaves so that fewer additional power inputs are needed. This can be achieved by disabling the Ethernet interface on each Slave unit as only the Master would require this interface to be active. The command is summarised below with full details at [Enable / Disable Ethernet Interface](#). The model datasheet contains full details of the daisy-chaining process.

`:nn:ETHERNET:Config:EthernetEnabled:0` Disable the Ethernet interface for Slave *nn*

## 2.2 - SCPI - General Commands

	Description	Command/Query
<b>a</b>	Get Model Name	:MN?
<b>b</b>	Get Serial Number	:SN?
<b>c</b>	Set Start-Up Attenuation Mode	:STARTUPATT:INDICATOR:[Mode]
<b>d</b>	Get Start-Up Attenuation Mode	:STARTUPATT:INDICATOR?
<b>e</b>	Store Last Attenuation Value	:LASTATT:STORE:INITIATE
<b>f</b>	Set USB Address	:SETADD:[Address]
<b>g</b>	Get USB Address	:ADD?
<b>h</b>	Get Firmware Version	:FIRMWARE?

### 2.2 (a) - Get Model Name

Returns the full Mini-Circuits part number of the attenuator.

#### Command Syntax

:MN?

#### Return String

MN=[model]

Variable	Description
[model]	Full model name of the attenuator

#### Examples

String to Send	String Returned
:MN?	MN=RCDAT-6000-90

HTTP Implementation: <http://10.10.10.10/:MN?>

#### See Also

[Get Serial Number](#)

## 2.2 (b) - Get Serial Number

Returns the serial number of the attenuator.

### Command Syntax

`:SN?`

### Return String

`SN=[serial]`

Variable	Description
<code>[serial]</code>	Serial number of the attenuator

### Examples

String to Send	String Returned
<code>:SN?</code>	<code>SN=11401010001</code>

HTTP Implementation: `http://10.10.10.10/:SN?`

### See Also

[Get Model Name](#)

## 2.2 (c) - Set Start-Up Attenuation Mode

Sets the start-up mode to be used by the attenuator, this specifies how the initial attenuation value will be chosen when DC power is applied.

### Requirements

Model Name	Serial Number	Firmware
RC8DAT series	All	All
RC4DAT series	All	All
RCDAT series	All	A6 or later
RUDAT series	All	A6 or later
ZVVA series	All	A6 or later

### Command Syntax

**:STARTUPATT:INDICATOR:[Mode]**

Variable	Value	Description
[Mode]	L	Last Attenuation - The attenuation will be set to the same level as when the device was last powered off
	F	Fixed Attenuation - The attenuation will be set to a user-defined value
	N	Default - The attenuator will assume the factory default state (maximum attenuation)

### Return String

**[Status]**

Variable	Value	Description
[Status]	0	Command failed
	1	Command completed successfully

### Examples

String to Send	String Returned
<b>:STARTUPATT:INDICATOR:L</b>	1
<b>:STARTUPATT:INDICATOR:F</b>	1
<b>:STARTUPATT:INDICATOR:N</b>	1

HTTP Implementation: `http://10.10.10.10/:STARTUPATT:INDICATOR:F`

### See Also

- [Get Start-Up Attenuation Mode](#)
- [Set Start-Up Attenuation Value](#)
- [Get Start-Up Attenuation Value](#)
- [Set Channel Start-Up Attenuation Value](#)
- [Get Channel Start-Up Attenuation Value](#)

## 2.2 (d) - Get Start-Up Attenuation Mode

Returns the start-up mode currently in use by the attenuator; this specifies how the initial attenuation value will be chosen when DC power is applied.

### Command Syntax

`:STARTUPATT:INDICATOR?`

### Requirements

Model Name	Serial Number	Firmware
RC8DAT series	All	All
RC4DAT series	All	All
RCDAT series	All	A6 or later
RUDAT series	All	A6 or later
ZVVA series	All	A6 or later

### Return String

[Mode]

Variable	Value	Description
[Mode]	L	Last Attenuation - The attenuation will be set to the same level as when the device was last powered off
	F	Fixed Attenuation - The attenuation will be set to a user-defined value
	N	Default - The attenuator will assume the factory default state (maximum attenuation)

### Examples

String to Send	String Returned
<code>:STARTUPATT:INDICATOR?</code>	L
<code>:STARTUPATT:INDICATOR?</code>	F
<code>:STARTUPATT:INDICATOR?</code>	N

HTTP Implementation: <http://10.10.10.10/:STARTUPATT:INDICATOR?>

### See Also

[Set Start-Up Attenuation Mode](#)  
[Set Start-Up Attenuation Value](#)  
[Get Start-Up Attenuation Value](#)  
[Set Channel Start-Up Attenuation Value](#)  
[Get Channel Start-Up Attenuation Value](#)

## 2.2 (e) - Store Last Attenuation Value

Saves the final attenuation value to internal memory; necessary before powering off the device when it has been configured to load the last known attenuation on next power up. If this is not the last command before powering off in this mode, the attenuator will re-start with the maximum attenuation value when it is next powered on.

### Requirements

Model Name	Serial Number	Firmware
RC8DAT series	All	All
RC4DAT series	All	All
RCDAT series	All	C3 or later
RUDAT series	All	C3 or later
ZVVA series	All	C3 or later

### Command Syntax

`:LASTATT:STORE:INITIATE`

### Return String

`[Status]`

Variable	Value	Description
<code>[Status]</code>	0	Command failed
	1	Command completed successfully

### Examples

String to Send	String Returned
<code>:LASTATT:STORE:INITIATE</code>	1

HTTP Implementation: `http://10.10.10.10/:LASTATT:STORE:INITIATE`

### See Also

[Set Start-Up Attenuation Mode](#)  
[Get Start-Up Attenuation Mode](#)

## 2.2 (f) - Set USB Address

Sets the device address to be used for USB communication (1 to 255).

### Command Syntax

**:SETADD:** [Address]

Variable	Value	Description
[Address]	1-255	The USB address

### Return String

[Status]

Variable	Value	Description
[Status]	0	Command failed or invalid address set
	1	Command completed successfully

### Examples

String to Send	String Returned
:SETADD:15	1

HTTP Implementation: <http://10.10.10.10/:SETADD:15>

### See Also

[Get USB Address](#)

## 2.2 (g) - Get USB Address

Returns the device address to be used for USB communication.

### Command Syntax

`:ADD?`

### Return String

`[Address]`

Variable	Value	Description
<code>[Address]</code>	1-255	The USB address

### Examples

String to Send	String Returned
<code>:ADD?</code>	15

HTTP Implementation: `http://10.10.10.10/:ADD?`

### See Also

[Set USB Address](#)

## 2.2 (h) - Get Firmware Version

Returns the internal firmware version number.

### Command Syntax

`:FIRMWARE?`

### Return String

`[Firmware]`

Variable	Description
<code>[Firmware]</code>	The firmware version number

### Examples

String to Send	String Returned
<code>:FIRMWARE?</code>	B1

HTTP Implementation: `http://10.10.10.10/:FIRMWARE?`

## 2.3 - SCPI - ZVVA / RUDAT / RCDAT (Single Channel) Attenuation Functions

	Description	Command/Query
a	Set Attenuation	:SETATT=[Att]
b	Read Attenuation	:ATT?
c	Set Start-Up Attenuation Value	:STARTUPATT:VALUE:[Att]
d	Get Start-Up Attenuation Value	:STARTUPATT:VALUE?
e	Set Attenuation Mode	:ATT_MODE[mode]
f	Query Attenuation Mode	:ATT_MODE?

### 2.3 (a) - Set Attenuation

Sets the attenuation for a single channel attenuator.

#### Applies To

ZVVA, RCDAT and RUDAT models

#### Command Syntax

**:SETATT=[Att]**

Variable	Description
[Att]	The attenuation to set

#### Return String

**[Status]**

Variable	Value	Description
[Status]	0	Command failed or invalid attenuation set
	1	Command completed successfully
	2	Requested attenuation was higher than the allowed range, the attenuation was set to the device's maximum allowed value

#### Examples

String to Send	String Returned
:SETATT=130	2
:SETATT=12.75	1

HTTP Implementation: `http://10.10.10.10/:SETATT=12.75`

#### See Also

[Read Attenuation](#)

## 2.3 (b) - Read Attenuation

Returns the current attenuation for a single channel attenuator.

### Applies To

ZVVA, RCDAT and RUDAT models

### Command Syntax

`:ATT?`

### Return String

`[Attenuation]`

Variable	Description
<code>[Attenuation]</code>	The attenuation in dB

### Examples

String to Send	String Returned
<code>:ATT?</code>	15.0 25.25 10.0 57.75

HTTP Implementation: <http://10.10.10.10/:ATT?>

### See Also

[Set Attenuation](#)

### 2.3 (c) - Set Start-Up Attenuation Value

Sets the attenuation value to be loaded when a single channel is first powered up. Only applies when the attenuator's start-up mode is set to "Fixed Attenuation".

#### Applies To

ZVVA, RUDAT and RCDAT models with firmware version A6 or later

#### Command Syntax

`:STARTUPATT:VALUE:[Att]`

Variable	Description
[Att]	The initial attenuation level to be loaded on start-up

#### Return String

[Status]

Variable	Value	Description
[Status]	0	Command failed
	1	Command completed successfully

#### Examples

String to Send	String Returned
<code>:STARTUPATT:VALUE:12.75</code>	1

HTTP Implementation: `http://10.10.10.10/:STARTUPATT:VALUE:12.75`

#### See Also

- [Set Start-Up Attenuation Mode](#)
- [Get Start-Up Attenuation Mode](#)
- [Get Start-Up Attenuation Value](#)

### 2.3 (d) - Get Start-Up Attenuation Value

Gets the attenuation value to be loaded when a single channel is first powered up. Only applies when the attenuator's start-up mode is set to "Fixed Attenuation".

#### Applies To

ZVVA, RUDAT and RCDAT models with firmware version A6 or later

#### Command Syntax

`:STARTUPATT:VALUE?`

#### Return String

`[Att]`

Variable	Description
<code>[Att]</code>	The initial attenuation level to be loaded on start-up

#### Examples

String to Send	String Returned
<code>:STARTUPATT:VALUE?</code>	12.75

HTTP Implementation: `http://10.10.10.10/:STARTUPATT:VALUE?`

#### See Also

- [Set Start-Up Attenuation Mode](#)
- [Get Start-Up Attenuation Mode](#)
- [Set Start-Up Attenuation Value](#)

### 2.3 (e) - Set Attenuation Mode (RCDAT-40G-30)

Sets which attenuation mode to use for RCDAT-40G-30, allowing best accuracy for either 0-30 dB attenuation in 1 dB steps (mode 1) or 0-29 dB in 0.5 dB steps (mode 2).

#### Applies To

RCDAT-40G-30

#### Command Syntax

`:ATT_MODE: [mode]`

Variable	Value	Description
[mode]	1	Attenuation from 0-30 dB in 1 dB steps
	2	Attenuation from 0-29 dB in 0.5 dB steps

#### Return String

`[Status]`

Variable	Value	Description
[Status]	0	Command failed
	1	Command completed successfully

#### Examples

String to Send	String Returned
<code>:ATT_MODE:1</code>	1
<code>:ATT_MODE:2</code>	1

HTTP Implementation: `http://10.10.10.10/:ATT_MODE:1`

#### See Also

[Query Attenuation Mode \(RCDAT-40G-30\)](#)

### 2.3 (f) - Query Attenuation Mode (RCDAT-40G-30)

Queries which attenuation mode is in use for RCDAT-40G-30, allowing best accuracy for either 0-30 dB attenuation in 1 dB steps (mode 1) or 0-29 dB in 0.5 dB steps (mode 2).

#### Applies To

RCDAT-40G-30

#### Command Syntax

`:ATT_MODE?`

#### Return String

`[mode]`

Variable	Value	Description
<code>[mode]</code>	1	Attenuation from 0-30 dB in 1 dB steps
	2	Attenuation from 0-29 dB in 0.5 dB steps

#### Examples

String to Send	String Returned
<code>:ATT_MODE?</code>	1
<code>:ATT_MODE?</code>	2

HTTP Implementation: `http://10.10.10.10/:ATT_MODE?`

#### See Also

[Set Attenuation Mode \(RCDAT-40G-30\)](#)

## 2.4 - SCPI - RC4DAT & RC8DAT (Multi-Channel) Attenuation Functions

	Description	Command/Query
<b>a</b>	Set Attenuation	:CHAN:[Channels]:SETATT:[Att]
<b>b</b>	Set Attenuation Per Channel	:SetAttPerChan:[Ch <sub>0</sub> :Att <sub>0</sub> ... _Ch <sub>n</sub> :Att <sub>n</sub> ]
<b>c</b>	Read Attenuation	:ATT?
<b>f</b>	Set Channel Start-Up Attenuation Value	:CHAN:[Channels]:STARTUPATT:VALUE:[Att]
<b>e</b>	Get Channel Start-Up Attenuation Value	:CHAN:[Channel]:STARTUPATT:VALUE?

## 2.4 (a) - Set Attenuation

Sets all selected channels of a multi-channel programmable attenuator to the same attenuation.

### Applies To

RC4DAT & RC8DAT Series

### Command Syntax

```
:CHAN: [Channels] :SETATT: [Att]
```

Variable	Description
[Channels]	The channel to set. Multiple channels can be sent by listing each channel number separated by a colon
[Att]	The attenuation to set for all channels listed above

### Return String

```
[Status]
```

Variable	Value	Description
[Status]	0	Command failed or invalid attenuation set
	1	Command completed successfully

### Examples

String to Send	String Returned
:CHAN:2:SETATT:15.75	1
:CHAN:1:3:4:SETATT:10	1

HTTP Implementation: <http://10.10.10.10/:CHAN:2:SETATT:15.75>

### See Also

[Set Attenuation Per Channel](#)  
[Read Attenuation](#)

## 2.4 (b) - Set Attenuation Per Channel

Sets multiple channels within a multi-channel attenuator with independent attenuation values. Takes a series of “channel number:attenuation value” pairs to specify the combination of channels and attenuations, with each pair separated by an underscore (\_) character. Each channel number and attenuation value is separated by a colon (:). It is not necessary to provide pairs for all channels, just the channels that are to be updated.

### Applies To

Model Name	Serial Number	Firmware
RC8DAT-8G-95	All	All
RC4DAT-8G-95	Up to 11910159999	D4 or later
	From 12001010001	All
RC4DAT-6G-95	Up to 11910299999	D4 or later
	From 11910300001	All
RC4DAT-6G-60	Up to 12007129999	D4 or later
	From 12007130001	All
RC4DAT-6G-30	Up to 12007129999	D4 or later
	From 12007239999	All
All Other Models	All	All

### Command Syntax

```
:SetAttPerChan: [Ch0] : [Att0] ... _ [Chn] : [Attn]
```

Variable	Description
[Ch <sub>0</sub> ]	The channel number for the first channel to be set
[Att <sub>0</sub> ]	The attenuation value (dB) for the first channel to be set
...	
[Ch <sub>n</sub> ]	The channel number for the n <sup>th</sup> channel to be set
[Att <sub>n</sub> ]	The attenuation value (dB) for the n <sup>th</sup> channel to be set

### Return String

```
[Status]
```

Variable	Value	Description
[Status]	0	Command failed or invalid attenuation set
	1	Command completed successfully

### Examples

String to Send	String Returned
<code>:SetAttPerChan:1:11.25_2:22.75_3:33_4:44.5</code>	1
<code>:SetAttPerChan:1:11.25_4:44.5</code>	1

HTTP Implementation: [http://10.10.10.10/:SetAttPerChan:1:11.25\\_4:44.5](http://10.10.10.10/:SetAttPerChan:1:11.25_4:44.5)

### See Also

[Set Attenuation](#)

[Read Attenuation](#)

## 2.4 (c) - Read Attenuation

Returns the current attenuation for all channels of a multi-channel attenuator.

### Command Syntax

`:ATT?`

### Return String

`[CH1_Att] [CH2_Att] [CH3_Att] [CH4_Att]`

Variable	Description
<code>[CH1_Att]</code>	Channel 1 attenuation (dB)
<code>[CH2_Att]</code>	Channel 2 attenuation (dB)
<code>[CH3_Att]</code>	Channel 3 attenuation (dB)
<code>[CH4_Att]</code>	Channel 4 attenuation (dB)

### Examples

String to Send	String Returned
<code>:ATT?</code>	15.0 25.25 10.0 57.75

HTTP Implementation: <http://10.10.10.10/:ATT?>

### See Also

[Set Attenuation](#)

[Set Attenuation Per Channel](#)

## 2.4 (d) - Set Channel Start-Up Attenuation Value

Sets the start up attenuation value for a single channel or channels within the multi-channel attenuator (the attenuation value to be loaded when DC power is applied). Only applies when the attenuator's start-up mode is set to "Fixed Attenuation".

### Applies To

RC4DAT & RC8DAT Series

### Command Syntax

`:CHAN:[Channels]:STARTUPATT:VALUE:[Att]`

Variable	Description
[Channels]	The channel to set. Multiple channels can be sent by listing each channel number separated by a colon
[Att]	The initial attenuation level to be loaded on start-up

### Return String

[Status]

Variable	Value	Description
[Status]	0	Command failed
	1	Command completed successfully

### Examples

String to Send	String Returned
<code>:CHAN:1:STARTUPATT:VALUE:12.75</code>	1
<code>:CHAN:1:2:STARTUPATT:VALUE:12.75</code>	1

HTTP Implementation: `http://10.10.10.10/:CHAN:1:STARTUPATT:VALUE:12.75`

### See Also

- [Set Start-Up Attenuation Mode](#)
- [Get Start-Up Attenuation Mode](#)
- [Get Channel Start-Up Attenuation Value](#)

## 2.4 (e) - Get Channel Start-Up Attenuation Value

Returns the start-up attenuation value for a single channel within the multi-channel attenuator (the attenuation value to be loaded when DC power is applied). Only applies when the attenuator's start-up mode is set to "Fixed Attenuation".

### Applies To

RC4DAT & RC8DAT Series

### Command Syntax

**:CHAN:** [Channel] **:STARTUPATT:VALUE?**

Variable	Description
<span style="color: green;">[Channel]</span>	The channel to query

### Return String

[Att]

Variable	Description
<span style="color: green;">[Att]</span>	The initial attenuation level to be loaded on start-up

### Examples

String to Send	String Returned
<b>:CHAN:2:STARTUPATT:VALUE?</b>	12.75

HTTP Implementation: <http://10.10.10.10/:CHAN:2:STARTUPATT:VALUE?>

### See Also

[Set Start-Up Attenuation Mode](#)  
[Get Start-Up Attenuation Mode](#)  
[Set Channel Start-Up Attenuation Value](#)

## 2.5 - SCPI - Daisy-Chain Options

These functions apply to Mini-Circuits' RCDAT-30G-30, RCDAT-40G-30 and RC4DAT-8G-120H programmable attenuators with daisy-chaining capability.

	Description	Command/Query
a	<a href="#">Assign Address</a>	:AssignAddresses
b	<a href="#">Count Number of Slaves</a>	:NumberOfSlaves?

### 2.5 (a) - Assign Addresses

Refreshes the distinct software address of each attenuator module connected within a Master / Slave daisy-chain.

The Master will automatically detect and issue addresses to all connected Slave units as soon as the USB or Ethernet connection to the Master is initiated. If any changes are made to the SPI connections between Master and Slaves after this point then the AssignAddresses command should be used to reissue addresses to all connected Slave switch modules.

Note: addresses are always issued in the order that Slaves are connected to the Master through the Serial Out / In control connections so changing the order of connection of Slave units also changes their addresses.

#### Applies To

RCDAT-30G-30 / RCDAT-40G-30 / RC4DAT-8G-120H

#### Command Syntax

`:AssignAddresses`

#### Return String

`[status]`

Variable	Description
<code>[status]</code>	Indication of whether the command was executed successfully

#### See Also

[Count Number of Slaves](#)

## 2.5 (b) - Count Number of Slaves

Refreshes the number of attenuator “slaves” connected to the Master attenuator when multiple devices have been connected in a serial control “daisy-chain”.

### Applies To

RCDAT-30G-30 / RCDAT-40G-30 / RC4DAT-8G-120H

### Command Syntax

`:NumberOfSlaves?`

### Return String

`[count]`

Variable	Description
<code>[count]</code>	The number of slaves connected into the Master

### See Also

[Assign Addresses](#)

## 2.6 - SCPI - Attenuation Hopping Commands

	Description	Command/Query
<b>a</b>	Hop - Set Number of Points	:HOP:POINTS:[NoOfPoints]
<b>b</b>	Hop - Get Number of Points	:HOP:POINTS?
<b>c</b>	Hop - Set Active Channels	:HOP:ACTIVECHANNELS:[CH_Value]
<b>d</b>	Hop - Get Active Channels	:HOP:ACTIVECHANNELS?
<b>e</b>	Hop - Set Sequence Direction	:HOP:DIRECTION:[Direction]
<b>f</b>	Hop - Get Sequence Direction	:HOP:DIRECTION?
<b>g</b>	Hop - Set Indexed Point	:HOP:POINT:[PointNo]
<b>h</b>	Hop - Get Indexed Point	:HOP:POINT?
<b>i</b>	Hop - Set Point Dwell Units	:HOP:DWELL_UNIT:[Units]
<b>j</b>	Hop - Set Point Dwell Time	:HOP:DWELL:[Time]
<b>k</b>	Hop - Get Point Dwell Time	:HOP:DWELL?
<b>l</b>	Hop - Set Point Attenuation	:HOP:ATT:[Att]
<b>m</b>	Hop - Set Channel Point Attenuation	:HOP:CHAN:[Channel]:ATT:[Att]
<b>n</b>	Hop - Get Point Attenuation	:HOP:ATT?
<b>o</b>	Hop - Get Channel Point Attenuation	:HOP:CHAN:[Channel]:ATT?
<b>p</b>	Hop - Turn On / Off	:HOP:MODE:[on_off]

Once an attenuation sequence is programmed and enabled, it is managed by the attenuator's internal microprocessor; this supports very fast sequences with minimum dwell times in the order of 600  $\mu$ s. It is not possible to query any attenuator parameters whilst the sequence is active so any subsequent command / query to the device will disable the sequence.

An alternative implementation method is to control the sequence and timing from your program, only sending "set attenuation" commands to the attenuator at the appropriate times. The advantage of this approach is that the program is able to query and keep track of the current attenuation state. The disadvantage is that the communication delays inherent in USB / Ethernet communication dictate a minimum dwell time in the order of milliseconds with this approach, rather than microseconds.

An example sequence of commands to configure a hop sequence is shown below:

```
:HOP:POINTS:10           // Create a hop sequence with 10 points
:HOP:ACTIVECHANNELS:15   // Set which channels to include in the hop
:HOP:DIRECTION:0         // Hop from first to last value in the list

// Set the first point
:HOP:POINT:0             // Index the first point in the sequence
:HOP:DWELL_UNIT:U // Set the dwell time in microseconds
:HOP:DWELL:800           // Set a dwell time of 800 µs
:HOP:CHAN:1:ATT:0        // Set attenuation for channel 1 on this hop
:HOP:CHAN:2:ATT:10       // Set attenuation for channel 2 on this hop
:HOP:CHAN:3:ATT:20       // Set attenuation for channel 3 on this hop
:HOP:CHAN:4:ATT:30       // Set attenuation for channel 4 on this hop

// Set points 2-9
// ...

// Set the last (tenth) point
:HOP:POINT:9             // Index the tenth point in the sequence
:HOP:DWELL_UNIT:U // Set the dwell time in microseconds
:HOP:DWELL:1600          // Set a dwell time of 1600 µs
:HOP:CHAN:1:ATT:50       // Set attenuation for channel 1 on this hop
:HOP:CHAN:2:ATT:60       // Set attenuation for channel 2 on this hop
:HOP:CHAN:3:ATT:70       // Set attenuation for channel 3 on this hop
:HOP:CHAN:4:ATT:80       // Set attenuation for channel 4 on this hop

:HOP:MODE:ON             // Enable the hop sequence

// Any subsequent command / query sent will stop the sequence
```

## 2.6 (a) - Hop Mode - Set Number of Points

Sets the number of points to be used in the attenuation hop sequence.

### Requirements

Model Name	Serial Number	Firmware
RC8DAT-8G-95	All	H4 or later
RC4DAT-8G-95	Up to 11910159999	E9 or later
	From 12001010001	H4 or later
RC4DAT-6G-95	Up to 11910299999	E9 or later
	From 11910300001	H4 or later
RC4DAT-6G-60	Up to 12007129999	E9 or later
	From 12007130001	H4 or later
RC4DAT-6G-30	Up to 12007129999	E9 or later
	From 12007239999	H4 or later
RCDAT, RUDAT & ZVVA series	All	E9 or later
All Other Models	All	All

### Command Syntax

`:HOP:POINTS:[NoOfPoints]`

Variable	Value	Description
<code>[NoOfPoints]</code>	1-1000	The number of points to set in the hop sequence

### Return String

`[Status]`

Variable	Value	Description
<code>[Status]</code>	0	Command failed
	1	Command completed successfully

### Examples

String to Send	String Returned
<code>:HOP:POINTS:10</code>	1

HTTP Implementation: `http://10.10.10.10/:HOP:POINTS:10`

### See Also

- [Hop Mode - Get Number of Points](#)
- [Hop Mode - Set Sequence Direction](#)
- [Hop Mode - Get Sequence Direction](#)

## 2.6 (b) - Hop Mode - Get Number of Points

Returns the number of points to be used in the attenuation hop sequence.

### Requirements

Model Name	Serial Number	Firmware
RC8DAT-8G-95	All	H4 or later
RC4DAT-8G-95	Up to 11910159999	E9 or later
	From 12001010001	H4 or later
RC4DAT-6G-95	Up to 11910299999	E9 or later
	From 11910300001	H4 or later
RC4DAT-6G-60	Up to 12007129999	E9 or later
	From 12007130001	H4 or later
RC4DAT-6G-30	Up to 12007129999	E9 or later
	From 12007239999	H4 or later
RCDAT, RUDAT & ZVVA series	All	E9 or later
All Other Models	All	All

### Command Syntax

`:HOP:POINTS?`

### Return String

`[NoOfPoints]`

Variable	Value	Description
<code>[NoOfPoints]</code>	1-1000	The number of points in the hop sequence

### Examples

String to Send	String Returned
<code>:HOP:POINTS?</code>	10

HTTP Implementation: `http://10.10.10.10/:HOP:POINTS?`

### See Also

- [Hop Mode - Set Number of Points](#)
- [Hop Mode - Set Sequence Direction](#)
- [Hop Mode - Get Sequence Direction](#)

## 2.6 (c) - Hop Mode - Set Active Channels

Sets which channels are to be included in the hop sequence for a multi-channel attenuator. This function does not apply to single channel models (ZVVA, RUDAT and RCDAT Series).

### Applies To

RC4DAT & RC8DAT Series

### Command Syntax

`:HOP:ACTIVECHANNELS:[CH_Value]`

Variable	Description
[CH_Value]	Integer value indicating the combination of channels to be included in the HOP. Each channel is represented by an integer: Channel 1 = 1 Channel 2 = 2 Channel 3 = 4 Channel 4 = 8 Channel 5 = 16 Channel 6 = 32 Channel 7 = 64 Channel 8 = 128 CH_Value is the sum of the above integer values for the channels to be included in the hop sequence. For example, to include channels 1, 2 and 4 in the sequence: CH_Value = 1 + 2 + 8 = 11

### Return String

[Status]

Variable	Value	Description
[Status]	0	Command failed
	1	Command completed successfully

### Examples

String to Send	String Returned
<code>:HOP:ACTIVECHANNELS:11</code>	1

HTTP Implementation: <http://10.10.10.10/:HOP:ACTIVECHANNELS:11>

### See Also

[Hop Mode - Get Active Channels](#)

## 2.6 (d) - Hop Mode - Get Active Channels

Returns which channels are to be included in the hop sequence for a multi-channel attenuator. This function does not apply to single channel models (ZVVA, RUDAT and RCDAT Series).

### Applies To

RC4DAT & RC8DAT Series

### Command Syntax

`:HOP:ACTIVECHANNELS?`

### Return String

`[CH_Value]`

Variable	Description
<code>[CH_Value]</code>	<p>Integer value corresponding to a 4-bit binary string, with each bit representing a channel in the multi-channel attenuator:</p> <ul style="list-style-type: none"> <li>Bit 3 (MSB) = Channel 4</li> <li>Bit 2 = Channel 3</li> <li>Bit 1 = Channel 2</li> <li>Bit 0 (LSB) = Channel 1</li> </ul> <p>A bit value of 1 indicates the channel is included in the hop whereas a bit value of 0 indicates it is not. For example:</p> <ul style="list-style-type: none"> <li>CH_Value = 11 (decimal) = 1011 (binary)</li> <li>Channel 4 = 1 (included in hop)</li> <li>Channel 3 = 0 (not included in hop)</li> <li>Channel 2 = 1 (not included in hop)</li> <li>Channel 1 = 1 (included in hop)</li> </ul>

### Examples

String to Send	String Returned
<code>:HOP:ACTIVECHANNELS?</code>	11

HTTP Implementation: <http://10.10.10.10/:HOP:ACTIVECHANNELS?>

### See Also

[Hop Mode - Set Active Channels](#)

## 2.6 (e) - Hop Mode - Set Sequence Direction

Sets the direction in which the attenuator will progress through the list of attenuation hops.

### Requirements

Model Name	Serial Number	Firmware
RC4DAT-8G-95	Up to 11910159999	B1 or later
	From 12001010001	All
RC4DAT-6G-95	Up to 11910299999	B1 or later
	From 11910300001	All
RC4DAT-6G-60	Up to 12007129999	B1 or later
	From 12007130001	All
RC4DAT-6G-30	Up to 12007129999	B1 or later
	From 12007239999	All
RCDAT, RUDAT & ZVVA series	All	B1 or later
All Other Models	All	All

### Command Syntax

**:HOP:DIRECTION: [Direction]**

Variable	Value	Description
[Direction]	0	Forward - The list of attenuation hops will be loaded from index 1 to index n
	1	Backwards - The list of attenuation hops will be loaded from index n to index 1
	2	Bi-directionally - The list of attenuation hops will be loaded in the forward and then reverse directions

### Return String

**[Status]**

Variable	Value	Description
[Status]	0	Command failed
	1	Command completed successfully

### Examples

String to Send	String Returned
:HOP:DIRECTION:0	1

HTTP Implementation: `http://10.10.10.10/:HOP:DIRECTION:0`

### See Also

- [Hop Mode - Set Number of Points](#)
- [Hop Mode - Get Number of Points](#)
- [Hop Mode - Get Sequence Direction](#)

## 2.6 (f) - Hop Mode - Get Sequence Direction

Returns the direction in which the attenuator will progress through the list of attenuation hops.

### Requirements

Model Name	Serial Number	Firmware
RC4DAT-8G-95	Up to 11910159999	B1 or later
	From 12001010001	All
RC4DAT-6G-95	Up to 11910299999	B1 or later
	From 11910300001	All
RC4DAT-6G-60	Up to 12007129999	B1 or later
	From 12007130001	All
RC4DAT-6G-30	Up to 12007129999	B1 or later
	From 12007239999	All
RCDAT, RUDAT & ZVVA series	All	B1 or later
All Other Models	All	All

### Command Syntax

`:HOP:DIRECTION?`

### Return String

`[Direction]`

Variable	Value	Description
<code>[Direction]</code>	0	Forward - The list of attenuation hops will be loaded from index 1 to index n
	1	Backwards - The list of attenuation hops will be loaded from index n to index 1
	2	Bi-directionally - The list of attenuation hops will be loaded in the forward and then reverse directions

### Examples

String to Send	String Returned
<code>:HOP:DIRECTION?</code>	0

HTTP Implementation: `http://10.10.10.10/:HOP:DIRECTION?`

### See Also

- [Hop Mode - Set Number of Points](#)
- [Hop Mode - Get Number of Points](#)
- [Hop Mode - Set Sequence Direction](#)

## 2.6 (g) - Hop Mode - Set Indexed Point

Defines which point in the hop sequence is currently indexed, this allows the parameters for that point to be configured (attenuation value and dwell time).

### Requirements

Model Name	Serial Number	Firmware
RC4DAT-8G-95	Up to 11910159999	B1 or later
	From 12001010001	All
RC4DAT-6G-95	Up to 11910299999	B1 or later
	From 11910300001	All
RC4DAT-6G-60	Up to 12007129999	B1 or later
	From 12007130001	All
RC4DAT-6G-30	Up to 12007129999	B1 or later
	From 12007239999	All
RCDAT, RUDAT & ZVVA series	All	B1 or later
All Other Models	All	All

### Command Syntax

`:HOP:POINT:[PointNo]`

Variable	Description
<code>[PointNo]</code>	The index number of the point in the hop sequence, from 0 to (n-1), where n is the number of points in the sequence

### Return String

`[Status]`

Variable	Value	Description
<code>[Status]</code>	0	Command failed
	1	Command completed successfully
	2	Point out of range (max number of points indexed instead)

### Examples

String to Send	String Returned
<code>:HOP:POINT:3</code>	1

HTTP Implementation: `http://10.10.10.10/:HOP:POINT:3`

### See Also

- [Hop Mode - Get Indexed Point](#)
- [Hop Mode - Set Point Attenuation](#)
- [Hop Mode - Set Channel Point Attenuation](#)
- [Hop Mode - Set Point Dwell Time Units](#)
- [Hop Mode - Set Point Dwell Time](#)

## 2.6 (h) - Hop Mode - Get Indexed Point

Returns the number of the indexed attenuation point within the hop sequence.

### Requirements

Model Name	Serial Number	Firmware
RC4DAT-8G-95	Up to 11910159999	B1 or later
	From 12001010001	All
RC4DAT-6G-95	Up to 11910299999	B1 or later
	From 11910300001	All
RC4DAT-6G-60	Up to 12007129999	B1 or later
	From 12007130001	All
RC4DAT-6G-30	Up to 12007129999	B1 or later
	From 12007239999	All
RCDAT, RUDAT & ZVVA series	All	B1 or later
All Other Models	All	All

### Command Syntax

`:HOP:POINT?`

### Return String

`[PointNo]`

Variable	Description
<code>[PointNo]</code>	The index number of the point in the hop sequence, from 0 to (n-1), where n is the number of points in the sequence

### Examples

String to Send	String Returned
<code>:HOP:POINT?</code>	3

HTTP Implementation: `http://10.10.10.10/:HOP:POINT?`

### See Also

- [Hop Mode - Set Indexed Point](#)
- [Hop Mode - Set Point Attenuation](#)
- [Hop Mode - Set Channel Point Attenuation](#)
- [Hop Mode - Set Point Dwell Time Units](#)
- [Hop Mode - Set Point Dwell Time](#)

## 2.6 (i) - Hop Mode - Set Point Dwell Time Units

Sets the units to be used for the dwell time of the indexed point in the hop sequence.

### Requirements

Model Name	Serial Number	Firmware
RC4DAT-8G-95	Up to 11910159999	B1 or later
	From 12001010001	All
RC4DAT-6G-95	Up to 11910299999	B1 or later
	From 11910300001	All
RC4DAT-6G-60	Up to 12007129999	B1 or later
	From 12007130001	All
RC4DAT-6G-30	Up to 12007129999	B1 or later
	From 12007239999	All
RCDAT, RUDAT & ZVVA series	All	B1 or later
All Other Models	All	All

### Command Syntax

```
:HOP:DWELL_UNIT:[Units]
```

Variable		Description
[Units]	U	Dwell time in microseconds ( $\mu$ s)
	M	Dwell time in milliseconds (ms)
	S	Dwell time in seconds (s)

### Return String

```
[Status]
```

Variable	Value	Description
[Status]	0	Command failed
	1	Command completed successfully

### Examples

String to Send	String Returned
:HOP:DWELL_UNIT:U	1
:HOP:DWELL_UNIT:M	1
:HOP:DWELL_UNIT:S	1

HTTP Implementation: [http://10.10.10.10/:HOP:DWELL\\_UNIT:U](http://10.10.10.10/:HOP:DWELL_UNIT:U)

### See Also

[Hop Mode - Set Point Dwell Time](#)  
[Hop Mode - Get Point Dwell Time](#)

## 2.6 (j) - Hop Mode - Set Point Dwell Time

Sets the dwell time of the indexed point in the hop sequence. The dwell time units are defined separately.

### Requirements

Model Name	Serial Number	Firmware
RC4DAT-8G-95	Up to 11910159999	B1 or later
	From 12001010001	All
RC4DAT-6G-95	Up to 11910299999	B1 or later
	From 11910300001	All
RC4DAT-6G-60	Up to 12007129999	B1 or later
	From 12007130001	All
RC4DAT-6G-30	Up to 12007129999	B1 or later
	From 12007239999	All
RCDAT, RUDAT & ZVVA series	All	B1 or later
All Other Models	All	All

### Command Syntax

`:HOP:DWELL:[Time]`

Variable	Description
<code>[Time]</code>	The dwell time of the indexed point

### Return String

`[Status]`

Variable	Value	Description
<code>[Status]</code>	0	Command failed
	1	Command completed successfully

### Examples

String to Send	String Returned
<code>:HOP:DWELL:650</code>	1

HTTP Implementation: <http://10.10.10.10/:HOP:DWELL:650>

### See Also

[Hop Mode - Set Point Dwell Time Units](#)

[Hop Mode - Get Point Dwell Time](#)

## 2.6 (k) - Hop Mode - Get Point Dwell Time

Gets the dwell time (including the units) of the indexed point in the hop sequence.

### Requirements

Model Name	Serial Number	Firmware
RC4DAT-8G-95	Up to 11910159999	B1 or later
	From 12001010001	All
RC4DAT-6G-95	Up to 11910299999	B1 or later
	From 11910300001	All
RC4DAT-6G-60	Up to 12007129999	B1 or later
	From 12007130001	All
RC4DAT-6G-30	Up to 12007129999	B1 or later
	From 12007239999	All
RCDAT, RUDAT & ZVVA series	All	B1 or later
All Other Models	All	All

### Command Syntax

`:HOP:DWELL?`

### Return String

`[Dwell] [Units]`

Variable	Value	Description
<code>[Dwell]</code>		The dwell time of the indexed point
<code>[Units]</code>	<code>uSec</code>	Dwell time in microseconds ( $\mu$ s)
	<code>mSec</code>	Dwell time in milliseconds (ms)
	<code>Sec</code>	Dwell time in seconds (s)

### Examples

String to Send	String Returned
<code>:HOP:DWELL?</code>	<code>625 uSec</code>
<code>:HOP:DWELL?</code>	<code>50 mSec</code>
<code>:HOP:DWELL?</code>	<code>2 Sec</code>

HTTP Implementation: `http://10.10.10.10/:HOP:DWELL?`

### See Also

[Hop Mode - Set Point Dwell Time Units](#)

[Hop Mode - Set Point Dwell Time](#)

## 2.6 (I) - Hop Mode - Set Point Attenuation

Sets the attenuation of the indexed hop point.

### Applies To

Model Name	Serial Number	Firmware
RCDAT, RUDAT & ZVVA series	All	B1 or later

### Command Syntax

`:HOP:ATT:[Att]`

Variable	Description
<code>[Att]</code>	The attenuation of the indexed hop point

### Return String

`[Status]`

Variable	Value	Description
<code>[Status]</code>	0	Command failed
	1	Command completed successfully

### Examples

String to Send	String Returned
<code>:HOP:ATT:75.5</code>	1

HTTP Implementation: `http://10.10.10.10/:HOP:ATT:75.5`

### See Also

[Hop Mode - Set Channel Point Attenuation](#)

[Hop Mode - Get Point Attenuation](#)

## 2.6 (m) - Hop Mode - Set Channel Point Attenuation

Sets the attenuation value of the indexed hop point for a specific channel within a multi-channel attenuator.

### Applies To

RC4DAT & RC8DAT Series

### Command Syntax

```
:HOP:CHAN: [Channel] :ATT: [Att]
```

Variable	Description
[Channel]	The channel to set
[Att]	The attenuation of the indexed hop point

### Return String

```
[Status]
```

Variable	Value	Description
[Status]	0	Command failed
	1	Command completed successfully

### Examples

String to Send	String Returned
<code>:HOP:ATT:75.5</code>	1

HTTP Implementation: `http://10.10.10.10/:HOP:ATT:75.5`

### See Also

[Hop Mode - Set Point Attenuation](#)

[Hop Mode - Get Channel Point Attenuation](#)

## 2.6 (n) - Hop Mode - Get Point Attenuation

Returns the attenuation of the indexed hop point.

### Applies To

Model Name	Serial Number	Firmware
RCDAT, RUDAT & ZVVA series	All	B1 or later

### Command Syntax

`:HOP:ATT?`

### Return String

`[Attenuation]`

Variable	Description
<code>[Attenuation]</code>	The attenuation of the indexed hop point

### Examples

String to Send	String Returned
<code>:HOP:ATT?</code>	75.50

HTTP Implementation: `http://10.10.10.10/:HOP:ATT?`

### See Also

[Hop Mode - Set Point Attenuation](#)

[Hop Mode - Get Channel Point Attenuation](#)

## 2.6 (o) - Hop Mode - Get Channel Point Attenuation

### Description

Sets the attenuation value of the indexed hop point for a specific channel within a multi-channel attenuator.

### Applies To

RC4DAT & RC8DAT Series

### Command Syntax

```
:HOP:CHAN:[Channel]:ATT?
```

Variable	Description
[Channel]	The channel to set (1 to 4)

### Return String

```
[Attenuation]
```

Variable	Description
[Attenuation]	The attenuation of the indexed hop point

### Examples

String to Send	String Returned
:HOP:ATT?	75.50
:HOP:CHAN:1:ATT?	75.50

HTTP Implementation: <http://10.10.10.10/:HOP:ATT?>

### See Also

[Hop Mode - Set Channel Point Attenuation](#)

[Hop Mode - Get Point Attenuation](#)

## 2.6 (p) - Hop Mode - Turn On / Off

Enables or disables the hop sequence according to the previously configured parameters.

Once an attenuation sequence is programmed and enabled, it is managed by the attenuator's internal microprocessor; this supports very fast sequences with minimum dwell times in the order of 600  $\mu$ s. It is not possible to query any attenuator parameters whilst the sequence is active so any subsequent command / query to the device will disable the sequence.

An alternative implementation method is to control the sequence and timing from your program, only sending "set attenuation" commands to the attenuator at the appropriate times. The advantage of this approach is that the program is able to query and keep track of the current attenuation state. The disadvantage is that the communication delays inherent in USB / Ethernet communication dictate a minimum dwell time in the order of milliseconds with this approach, rather than microseconds.

### Requirements

Model Name	Serial Number	Firmware
RC4DAT-8G-95	Up to 11910159999	B1 or later
	From 12001010001	All
RC4DAT-6G-95	Up to 11910299999	B1 or later
	From 11910300001	All
RC4DAT-6G-60	Up to 12007129999	B1 or later
	From 12007130001	All
RC4DAT-6G-30	Up to 12007129999	B1 or later
	From 12007239999	All
RCDAT, RUDAT & ZVVA series	All	B1 or later
All Other Models	All	All

### Command Syntax

`:HOP:MODE:[On_Off]`

Variable	Value	Description
[On_Off]	ON	Enable the hop sequence using the previously configured list of attenuation hops
	OFF	Disable the hop sequence

### Return String

`[Status]`

Variable	Value	Description
[Status]	0	Command failed
	1	Command completed successfully

### Examples

String to Send	String Returned
<code>:HOP:MODE:ON</code>	1
<code>:HOP:MODE:OFF</code>	1

HTTP Implementation: <http://10.10.10.10/:HOP:MODE:ON>

## 2.7 - SCPI - Attenuation Sweeping / Fading Commands

	Description	Command/Query
a	Sweep - Set Direction	SWEEP:DIRECTION:[Direction]
b	Sweep - Get Direction	SWEEP:DIRECTION?
c	Sweep - Set Dwell Units	SWEEP:DWELL_UNIT:[Units]
d	Sweep - Set Dwell Time	SWEEP:DWELL:[Time]
e	Sweep - Get Dwell Time	SWEEP:DWELL?
f	Sweep - Set Active Channels	SWEEP:ACTIVECHANNELS:[CH_Value]
g	Sweep - Get Active Channels	SWEEP:ACTIVECHANNELS?
h	Sweep - Set Start Attenuation	SWEEP:START:[Att]
i	Sweep - Set Channel Start Attenuation	SWEEP:CHAN:[Channel]:START:[Att]
j	Sweep - Get Start Attenuation	SWEEP:START?
k	Sweep - Get Channel Start Attenuation	SWEEP:CHAN:[Channel]:START?
l	Sweep - Set Stop Attenuation	SWEEP:STOP:[Att]
m	Sweep - Set Channel Stop Attenuation	SWEEP:CHAN:[Channel]:STOP:[Att]
n	Sweep - Get Stop Attenuation	SWEEP:STOP?
o	Sweep - Get Channel Stop Attenuation	SWEEP:CHAN:[Channel]:STOP?
p	Sweep - Set Step Size	SWEEP:STEP_SIZE:[Att]
q	Sweep - Set Channel Step Size	SWEEP:CHAN:[Channel]:STEP_SIZE:[Att]
r	Sweep - Get Step Size	SWEEP:STEP_SIZE?
s	Sweep - Get Channel Step Size	SWEEP:CHAN:[Channel]:STEP_SIZE?
t	Sweep - Turn On / Off	SWEEP:MODE:[on_off]

Once an attenuation sequence is programmed and enabled, it is managed by the attenuator's internal microprocessor; this supports very fast sequences with minimum dwell times in the order of 600  $\mu$ s. It is not possible to query any attenuator parameters whilst the sequence is active so any subsequent command / query to the device will disable the sequence.

An alternative implementation method is to control the sequence and timing from your program, only sending "set attenuation" commands to the attenuator at the appropriate times. The advantage of this approach is that the program is able to query and keep track of the current attenuation state. The disadvantage is that the communication delays inherent in USB / Ethernet communication dictate a minimum dwell time in the order of milliseconds with this approach, rather than microseconds.

An example sequence of commands to configure a sweep sequence is shown below:

```
:SWEEP:DIRECTION:0           // Sweep from start value to stop value
:SWEEP:DWELL_UNIT:U          // Set the dwell time in microseconds
:SWEEP:DWELL:800             // Set a dwell time of 800  $\mu$ s
:SWEEP:ACTIVECHANNELS:15    // Set which channels to include
:SWEEP:CHAN:1:START:0        // Set start value for channel 1 (0 dB)
:SWEEP:CHAN:2:START:0        // Set start value for channel 2 (0 dB)
:SWEEP:CHAN:3:START:0        // Set start value for channel 3 (0 dB)
:SWEEP:CHAN:4:START:0        // Set start value for channel 4 (0 dB)
:SWEEP:CHAN:1:STOP:65        // Set stop value for channel 1 (65 dB)
:SWEEP:CHAN:2:STOP:65        // Set stop value for channel 2 (65 dB)
:SWEEP:CHAN:3:STOP:65        // Set stop value for channel 3 (65 dB)
:SWEEP:CHAN:4:STOP:65        // Set stop value for channel 4 (65 dB)
:SWEEP:CHAN:1:STEP:0.25      // Set step size for chan1 (0.25 dB)
:SWEEP:CHAN:2:STEP:0.25      // Set step size for chan 2 (0.25 dB)
:SWEEP:CHAN:3:STEP:0.25      // Set step size for chan3 (0.25 dB)
:SWEEP:CHAN:4:STEP:0.25      // Set step size for chan4 (0.25 dB)
:SWEEP:MODE:ON               // Enable the sweep

// Any subsequent command / query sent will stop the sequence
```

## 2.7 (a) - Sweep Mode - Set Sweep Direction

Sets the direction in which the attenuation level will sweep.

### Requirements

Model Name	Serial Number	Firmware
RC4DAT-8G-95	Up to 11910159999	B1 or later
	From 12001010001	All
RC4DAT-6G-95	Up to 11910299999	B1 or later
	From 11910300001	All
RC4DAT-6G-60	Up to 12007129999	B1 or later
	From 12007130001	All
RC4DAT-6G-30	Up to 12007129999	B1 or later
	From 12007239999	All
RCDAT, RUDAT & ZVVA series	All	B1 or later
All Other Models	All	All

### Command Syntax

**:SWEEP:DIRECTION: [Direction]**

Variable	Value	Description
[Direction]	0	Forward - Sweep from "Start" to "Stop" value
	1	Backwards - Sweep from "Stop" to "Start" value
	2	Bi-directionally - Sweep in the forward and then reverse directions

### Return String

**[Status]**

Variable	Value	Description
[Status]	0	Command failed
	1	Command completed successfully

### Examples

String to Send	String Returned
:SWEEP:DIRECTION:0	1

HTTP Implementation: <http://10.10.10.10/:SWEEP:DIRECTION:0>

### See Also

[Sweep Mode - Get Sweep Direction](#)

## 2.7 (b) - Sweep Mode - Get Sweep Direction

Returns the direction in which the attenuation level will sweep.

### Requirements

Model Name	Serial Number	Firmware
RC4DAT-8G-95	Up to 11910159999	B1 or later
	From 12001010001	All
RC4DAT-6G-95	Up to 11910299999	B1 or later
	From 11910300001	All
RC4DAT-6G-60	Up to 12007129999	B1 or later
	From 12007130001	All
RC4DAT-6G-30	Up to 12007129999	B1 or later
	From 12007239999	All
RCDAT, RUDAT & ZVVA series	All	B1 or later
All Other Models	All	All

### Command Syntax

`:SWEEP:DIRECTION?`

### Return String

`[Direction]`

Variable	Value	Description
<code>[Direction]</code>	0	Forward - Sweep from "Start" to "Stop" value
	1	Backwards - Sweep from "Stop" to "Start" value
	2	Bi-directionally - Sweep in the forward and then reverse directions

### Examples

String to Send	String Returned
<code>:SWEEP:DIRECTION?</code>	0

HTTP Implementation: <http://10.10.10.10/:SWEEP:DIRECTION?>

### See Also

[Sweep Mode - Set Sweep Direction](#)

## 2.7 (c) - Sweep Mode - Set Dwell Time Units

Sets the units to be used for the sweep dwell time.

### Requirements

Model Name	Serial Number	Firmware
RC4DAT-8G-95	Up to 11910159999	B1 or later
	From 12001010001	All
RC4DAT-6G-95	Up to 11910299999	B1 or later
	From 11910300001	All
RC4DAT-6G-60	Up to 12007129999	B1 or later
	From 12007130001	All
RC4DAT-6G-30	Up to 12007129999	B1 or later
	From 12007239999	All
RCDAT, RUDAT & ZVVA series	All	B1 or later
All Other Models	All	All

### Command Syntax

```
:SWEEP:DWELL_UNIT:[Units]
```

Variable		Description
[Units]	U	Dwell time in microseconds ( $\mu$ s)
	M	Dwell time in milliseconds (ms)
	S	Dwell time in seconds (s)

### Return String

```
[Status]
```

Variable	Value	Description
[Status]	0	Command failed
	1	Command completed successfully

### Examples

String to Send	String Returned
:SWEEP:DWELL_UNIT:U	1
:SWEEP:DWELL_UNIT:M	1
:SWEEP:DWELL_UNIT:S	1

HTTP Implementation: [http://10.10.10.10/:SWEEP:DWELL\\_UNIT:U](http://10.10.10.10/:SWEEP:DWELL_UNIT:U)

### See Also

[Sweep Mode - Set Point Dwell Time](#)

[Sweep Mode - Get Dwell Time](#)

## 2.7 (d) - Sweep Mode - Set Dwell Time

Sets the dwell time to be used for the sweep. The dwell time units are defined separately.

### Requirements

Model Name	Serial Number	Firmware
RC4DAT-8G-95	Up to 11910159999	B1 or later
	From 12001010001	All
RC4DAT-6G-95	Up to 11910299999	B1 or later
	From 11910300001	All
RC4DAT-6G-60	Up to 12007129999	B1 or later
	From 12007130001	All
RC4DAT-6G-30	Up to 12007129999	B1 or later
	From 12007239999	All
RCDAT, RUDAT & ZVVA series	All	B1 or later
All Other Models	All	All

### Command Syntax

`:SWEEP:DWELL:[Time]`

Variable	Description
<code>[Time]</code>	The dwell time of the indexed point

### Return String

`[Status]`

Variable	Value	Description
<code>[Status]</code>	0	Command failed
	1	Command completed successfully

### Examples

String to Send	String Returned
<code>:SWEEP:DWELL:650</code>	1

HTTP Implementation: `http://10.10.10.10/:SWEEP:DWELL:650`

### See Also

[Sweep Mode - Set Dwell Time Units](#)  
[Sweep Mode - Get Dwell Time](#)

## 2.7 (e) - Sweep Mode - Get Dwell Time

Gets the dwell time (including the units) of the attenuation sweep.

### Requirements

Model Name	Serial Number	Firmware
RC4DAT-8G-95	Up to 11910159999	B1 or later
	From 12001010001	All
RC4DAT-6G-95	Up to 11910299999	B1 or later
	From 11910300001	All
RC4DAT-6G-60	Up to 12007129999	B1 or later
	From 12007130001	All
RC4DAT-6G-30	Up to 12007129999	B1 or later
	From 12007239999	All
RCDAT, RUDAT & ZVVA series	All	B1 or later
All Other Models	All	All

### Command Syntax

`:SWEEP:DWELL?`

### Return String

`[Dwell] [Units]`

Variable	Value	Description
<code>[Dwell]</code>		The dwell time of the sweep
<code>[Units]</code>	<code>uSec</code>	Dwell time in microseconds ( $\mu$ s)
	<code>mSec</code>	Dwell time in milliseconds (ms)
	<code>Sec</code>	Dwell time in seconds (s)

### Examples

String to Send	String Returned
<code>:SWEEP:DWELL?</code>	<code>625 uSec</code>
<code>:SWEEP:DWELL?</code>	<code>50 mSec</code>
<code>:SWEEP:DWELL?</code>	<code>2 Sec</code>

HTTP Implementation: <http://10.10.10.10/:SWEEP:DWELL?>

### See Also

[Sweep Mode - Set Dwell Time Units](#)

[Sweep Mode - Set Dwell Time](#)

## 2.7 (f) - Sweep Mode - Set Active Channels

Sets which channels are to be included in the sweep for a multi-channel attenuator. This function does not apply to single channel models (ZVVA, RUDAT and RCDAT Series).

### Applies To

RC4DAT & RC8DAT Series

### Command Syntax

`:SWEEP:ACTIVECHANNELS:[CH_Value]`

Variable	Description
[CH_Value]	Integer value indicating the combination of channels to be included in the sweep. Each channel is represented by an integer: Channel 1 = 1 Channel 2 = 2 Channel 3 = 4 Channel 4 = 8 CH_Value is the sum of the above integer values for the channels to be included in the sweep. For example, to include channels 1, 2 and 4 in the sequence: CH_Value = 1 + 2 + 8 = 11

### Return String

[Status]

Variable	Value	Description
[Status]	0	Command failed
	1	Command completed successfully

### Examples

String to Send	String Returned
<code>:SWEEP:ACTIVECHANNELS:11</code>	1

HTTP Implementation: <http://10.10.10.10/:SWEEP:ACTIVECHANNELS:11>

### See Also

[Sweep Mode - Get Active Channels](#)

## 2.7 (g) - Sweep Mode - Get Active Channels

Returns which channels are to be included in the sweep for a multi-channel attenuator. This function does not apply to single channel models (ZVVA, RUDAT and RCDAT Series).

### Applies To

RC4DAT & RC8DAT Series

### Command Syntax

`:SWEEP:ACTIVECHANNELS?`

### Return String

`[CH_Value]`

Variable	Description
<code>[CH_Value]</code>	<p>Integer value corresponding to a 4-bit binary string, with each bit representing a channel in the multi-channel attenuator:</p> <ul style="list-style-type: none"> <li>Bit 3 (MSB) = Channel 4</li> <li>Bit 2 = Channel 3</li> <li>Bit 1 = Channel 2</li> <li>Bit 0 (LSB) = Channel 1</li> </ul> <p>A bit value of 1 indicates the channel is included in the sweep whereas a bit value of 0 indicates it is not. For example:</p> <p>CH_Value = 11 (decimal) = 1011 (binary)</p> <ul style="list-style-type: none"> <li>Channel 4 = 1 (included in sweep)</li> <li>Channel 3 = 0 (not included in sweep)</li> <li>Channel 2 = 1 (not included in sweep)</li> <li>Channel 1 = 1 (included in sweep)</li> </ul>

### Examples

String to Send	String Returned
<code>:SWEEP:ACTIVECHANNELS?</code>	11

HTTP Implementation: <http://10.10.10.10/:SWEEP:ACTIVECHANNELS?>

### See Also

[Sweep Mode - Set Active Channels](#)

## 2.7 (h) - Sweep Mode - Set Start Attenuation

Sets the first attenuation level to be loaded during the sweep.

### Applies To

Model Name	Serial Number	Firmware
RCDAT, RUDAT & ZVVA series	All	B1 or later

### Command Syntax

`:SWEEP:START:[Att]`

Variable	Description
<code>[Att]</code>	The initial attenuation level to set

### Return String

`[Status]`

Variable	Value	Description
<code>[Status]</code>	0	Command failed
	1	Command completed successfully

### Examples

String to Send	String Returned
<code>:SWEEP:START:0</code>	1

HTTP Implementation: `http://10.10.10.10/:SWEEP:START:0`

### See Also

- [Sweep Mode - Set Channel Start Attenuation](#)
- [Sweep Mode - Get Start Attenuation](#)
- [Sweep Mode - Set Stop Attenuation](#)
- [Sweep Mode - Set Step Size](#)

## 2.7 (i) - Sweep Mode - Set Channel Start Attenuation

Sets the first attenuation level to be loaded during the sweep for a specific channel within a multi-channel attenuator.

### Applies To

RC4DAT & RC8DAT Series

### Command Syntax

```
:SWEEP:CHAN: [Channel] :START: [Att]
```

Variable	Description
[Channel]	The channel to set
[Att]	The initial attenuation level to set

### Return String

```
[Status]
```

Variable	Value	Description
[Status]	0	Command failed
	1	Command completed successfully

### Examples

String to Send	String Returned
<code>:SWEEP:CHAN:1:START:0</code>	1

HTTP Implementation: <http://10.10.10.10/:SWEEP:CHAN:1:START:0>

### See Also

- [Sweep Mode - Set Start Attenuation](#)
- [Sweep Mode - Get Channel Start Attenuation](#)
- [Sweep Mode - Set Channel Stop Attenuation](#)
- [Sweep Mode - Set Channel Step Size](#)

## 2.7 (j) - Sweep Mode - Get Start Attenuation

Returns the first attenuation level to be loaded during the sweep.

### Applies To

Model Name	Serial Number	Firmware
RCDAT, RUDAT & ZVVA series	All	B1 or later

### Command Syntax

`:SWEEP:START?`

### Return String

`[Attenuation]`

Variable	Description
<code>[Attenuation]</code>	The initial attenuation level to be set during the sweep

### Examples

String to Send	String Returned
<code>:SWEEP:START?</code>	0.0

HTTP Implementation: `http://10.10.10.10/:SWEEP:START?`

### See Also

- [Sweep Mode - Set Start Attenuation](#)
- [Sweep Mode - Get Channel Start Attenuation](#)
- [Sweep Mode - Get Stop Attenuation](#)
- [Sweep Mode - Get Step Size](#)

## 2.7 (k) - Sweep Mode - Get Channel Start Attenuation

Returns the first attenuation level to be loaded during the sweep for a specific channel within a multi-channel attenuator.

### Applies To

RC4DAT & RC8DAT Series

### Command Syntax

```
:SWEEP:CHAN:[Channel]:START?
```

Variable	Description
[Channel]	The channel to query (1 to 4)

### Return String

```
[Attenuation]
```

Variable	Description
[Attenuation]	The initial attenuation level to be set during the sweep

### Examples

String to Send	String Returned
<code>:SWEEP:CHAN:1:START?</code>	0.0

HTTP Implementation: `http://10.10.10.10/:SWEEP:CHAN:1:START?`

### See Also

- [Sweep Mode - Set Channel Start Attenuation](#)
- [Sweep Mode - Get Start Attenuation](#)
- [Sweep Mode - Get Channel Stop Attenuation](#)
- [Sweep Mode - Get Channel Step Size](#)

## 2.7 (I) - Sweep Mode - Set Stop Attenuation

Sets the final attenuation level to be loaded during the sweep.

### Requirements

Model Name	Serial Number	Firmware
RCDAT, RUDAT & ZVVA series	All	B1 or later

### Command Syntax

**:SWEEP:START:[Att]**

Variable	Description
[Att]	The final attenuation level to set

### Return String

**[Status]**

Variable	Value	Description
[Status]	0	Command failed
	1	Command completed successfully

### Examples

String to Send	String Returned
<b>:SWEEP:STOP:65.75</b>	1

HTTP Implementation: <http://10.10.10.10/:SWEEP:STOP:65.75>

### See Also

- [Sweep Mode - Get Stop Attenuation](#)
- [Sweep Mode - Set Start Attenuation](#)
- [Sweep Mode - Set Channel Stop Attenuation](#)
- [Sweep Mode - Set Step Size](#)

## 2.7 (m) - Sweep Mode - Set Channel Stop Attenuation

Sets the final attenuation level to be loaded during the sweep for a specific channel within a multi-channel attenuator.

### Applies To

RC4DAT & RC8DAT Series

### Command Syntax

```
:SWEEP:CHAN: [Channel] :STOP: [Att]
```

Variable	Description
[Channel]	The channel to set
[Att]	The final attenuation level to set

### Return String

```
[Status]
```

Variable	Value	Description
[Status]	0	Command failed
	1	Command completed successfully

### Examples

String to Send	String Returned
<code>:SWEEP:CHAN:1:STOP:90</code>	1

HTTP Implementation: <http://10.10.10.10/:SWEEP:CHAN:1:STOP:90>

### See Also

- [Sweep Mode - Set Channel Start Attenuation](#)
- [Sweep Mode - Set Stop Attenuation](#)
- [Sweep Mode - Get Channel Stop Attenuation](#)
- [Sweep Mode - Set Channel Step Size](#)

## 2.7 (n) - Sweep Mode - Get Stop Attenuation

Returns the final attenuation level to be loaded during the sweep.

### Requirements

Model Name	Serial Number	Firmware
RCDAT, RUDAT & ZVVA series	All	B1 or later

### Command Syntax

`:SWEEP:STOP?`

### Return String

`[Attenuation]`

Variable	Description
<code>[Attenuation]</code>	The final attenuation level to be set during the sweep

### Examples

String to Send	String Returned
<code>:SWEEP:STOP?</code>	65.75

HTTP Implementation: `http://10.10.10.10/:SWEEP:STOP?`

### See Also

- [Sweep Mode - Set Stop Attenuation](#)
- [Sweep Mode - Get Start Attenuation](#)
- [Sweep Mode - Get Channel Stop Attenuation](#)
- [Sweep Mode - Get Step Size](#)

## 2.7 (o) - Sweep Mode - Get Channel Stop Attenuation

Returns the final attenuation level to be loaded during the sweep for a specific channel within a multi-channel attenuator.

### Applies To

RC4DAT & RC8DAT Series

### Command Syntax

```
:SWEEP:CHAN:[Channel]:STOP?
```

Variable	Description
[Channel]	The channel to query (1 to 4)

### Return String

```
[Attenuation]
```

Variable	Description
[Attenuation]	The final attenuation level to be set during the sweep

### Examples

String to Send	String Returned
<code>:SWEEP:CHAN:1:STOP?</code>	0.0

HTTP Implementation: `http://10.10.10.10/:SWEEP:STOP?`

### See Also

- [Sweep Mode - Get Channel Start Attenuation](#)
- [Sweep Mode - Set Channel Stop Attenuation](#)
- [Sweep Mode - Get Stop Attenuation](#)
- [Sweep Mode - Get Channel Step Size](#)

## 2.7 (p) - Sweep Mode - Set Step Size

Sets the attenuation step size that will be used to increment the attenuation from the start to stop levels (or decrement from stop to start if the sweep is running in the reverse direction).

### Applies To

Model Name	Serial Number	Firmware
RCDAT, RUDAT & ZVVA series	All	B1 or later

### Command Syntax

`:SWEEP:STEPSize: [Att]`

Variable	Description
<code>[Att]</code>	The attenuation step size

### Return String

`[Status]`

Variable	Value	Description
<code>[Status]</code>	0	Command failed
	1	Command completed successfully

### Examples

String to Send	String Returned
<code>:SWEEP:STEPSize:0.5</code>	1

HTTP Implementation: `http://10.10.10.10/:SWEEP:STEPSize:0.5`

### See Also

- [Sweep Mode - Get Step Size](#)
- [Sweep Mode - Set Start Attenuation](#)
- [Sweep Mode - Set Stop Attenuation](#)
- [Sweep Mode - Set Channel Step Size](#)

## 2.7 (q) - Sweep Mode - Set Channel Step Size

Sets the attenuation step size for a multi-channel attenuator that will be used to increment the attenuation from the start to stop levels (or decrement from stop to start if the sweep is running in the reverse direction).

### Applies To

RC4DAT & RC8DAT Series

### Command Syntax

`:SWEEP:CHAN:[Channel]:STEPsize:[Att]`

Variable	Description
[Channel]	The channel to set
[Att]	The attenuation step size

### Return String

`[Status]`

Variable	Value	Description
[Status]	0	Command failed
	1	Command completed successfully

### Examples

String to Send	String Returned
<code>:SWEEP:CHAN:1:STEPsize:0.5</code>	1

HTTP Implementation: `http://10.10.10.10/:SWEEP:CHAN:1:STEPsize:0.5`

### See Also

- [Sweep Mode - Set Channel Start Attenuation](#)
- [Sweep Mode - Set Channel Stop Attenuation](#)
- [Sweep Mode - Set Step Size](#)
- [Sweep Mode - Get Channel Step Size](#)

## 2.7 (r) - Sweep Mode - Get Step Size

Returns the attenuation step size that will be used to increment the attenuation from the start to stop levels (or decrement from stop to start if the sweep is running in the reverse direction).

### Applies To

Model Name	Serial Number	Firmware
RCDAT, RUDAT & ZVVA series	All	B1 or later

### Command Syntax

`:SWEEP:STEPSIZE?`

### Return String

`[Attenuation]`

Variable	Description
<code>[Attenuation]</code>	The attenuation step size

### Examples

String to Send	String Returned
<code>:SWEEP:STEPSIZE?</code>	0.50

HTTP Implementation: <http://10.10.10.10/:SWEEP:STEPSIZE?>

### See Also

- [Sweep Mode - Set Step Size](#)
- [Sweep Mode - Get Start Attenuation](#)
- [Sweep Mode - Get Stop Attenuation](#)
- [Sweep Mode - Get Channel Step Size](#)

## 2.7 (s) - Sweep Mode - Get Channel Step Size

Returns the attenuation step size for a multi-channel attenuators that will be used to increment the attenuation from the start to stop levels (or decrement from stop to start if the sweep is running in the reverse direction).

### Applies To

RC4DAT & RC8DAT series

### Command Syntax

```
:SWEEP:CHAN:[Channel]:STEPSize?
```

Variable	Description
[Channel]	The channel to query (1 to 4)

### Return String

```
[Attenuation]
```

Variable	Description
[Attenuation]	The attenuation step size

### Examples

String to Send	String Returned
<code>:SWEEP:CHAN:1:STEPSize?</code>	0.50

HTTP Implementation: `http://10.10.10.10/:SWEEP:CHAN:1:STEPSize?`

### See Also

- [Sweep Mode - Get Channel Start Attenuation](#)
- [Sweep Mode - Get Channel Stop Attenuation](#)
- [Sweep Mode - Set Channel Step Size](#)
- [Sweep Mode - Get Step Size](#)

## 2.7 (t) - Sweep Mode - Turn On / Off

Enables or disable the attenuation sweep sequence according to the parameters set.

Once an attenuation sequence is programmed and enabled, it is managed by the attenuator's internal microprocessor; this supports very fast sequences with minimum dwell times in the order of 600  $\mu$ s. It is not possible to query any attenuator parameters whilst the sequence is active so any subsequent command / query to the device will disable the sequence.

An alternative implementation method is to control the sequence and timing from your program, only sending "set attenuation" commands to the attenuator at the appropriate times. The advantage of this approach is that the program is able to query and keep track of the current attenuation state. The disadvantage is that the communication delays inherent in USB / Ethernet communication dictate a minimum dwell time in the order of milliseconds with this approach, rather than microseconds.

### Requirements

Model Name	Serial Number	Firmware
RC4DAT-8G-95	Up to 11910159999	B1 or later
	From 12001010001	All
RC4DAT-6G-95	Up to 11910299999	B1 or later
	From 11910300001	All
RC4DAT-6G-60	Up to 12007129999	B1 or later
	From 12007130001	All
RC4DAT-6G-30	Up to 12007129999	B1 or later
	From 12007239999	All
RCDAT, RUDAT & ZVVA series	All	B1 or later
All Other Models	All	All

### Command Syntax

`:SWEEP:MODE:[On_Off]`

Variable	Value	Description
[On_Off]	ON	Enable the sweep sequence according to the previously configured parameters
	OFF	Disable the sweep sequence

### Return String

`[Status]`

Variable	Value	Description
[Status]	0	Command failed
	1	Command completed successfully

### Examples

String to Send	String Returned
<code>:SWEEP:MODE:ON</code>	1
<code>:SWEEP:MODE:OFF</code>	1

HTTP Implementation: <http://10.10.10.10/:SWEEP:MODE:ON>

## 2.8 - SCPI - Ethernet Configuration Commands

	Description	Command/Query
a	Set Static IP Address	:ETHERNET:CONFIG:IP:[ip]
b	Get Static IP Address	:ETHERNET:CONFIG:IP?
c	Set Static Subnet Mask	:ETHERNET:CONFIG:SM:[mask]
d	Get Static Subnet Mask	:ETHERNET:CONFIG:SM?
e	Set Static Network Gateway	:ETHERNET:CONFIG:NG:[gateway]
f	Get Static Network Gateway	:ETHERNET:CONFIG:NG?
g	Set HTTP Port	:ETHERNET:CONFIG:HTPORT:[port]
h	Get HTTP Port	:ETHERNET:CONFIG:HTPORT?
i	Set Telnet Port	:ETHERNET:CONFIG:TELNETPORT:[port]
j	Get Telnet Port	:ETHERNET:CONFIG:TELNETPORT?
k	Enable Custom Telnet Prompt	:ETHERNET:CONFIG:TELNETPROMPTENABLED:[state]
l	Query Telnet Prompt Type	:ETHERNET:CONFIG:TELNETPROMPTENABLED?
m	Set Custom Telnet Prompt Text	:ETHERNET:CONFIG:TELNETPROMPTTEXT:[text]
n	Get Custom Telnet Prompt Text	:ETHERNET:CONFIG:TELNETPROMPTTEXT?
o	Set Password Requirement	:ETHERNET:CONFIG:PWDENABLED:[enabled]
p	Get Password Requirement	:ETHERNET:CONFIG:PWDENABLED?
q	Set Password	:ETHERNET:CONFIG:PWD:[pwd]
r	Get Password	:ETHERNET:CONFIG:PWD?
s	Set DHCP Status	:ETHERNET:CONFIG:DHCPENABLED:[enabled]
t	Get DHCP Status	:ETHERNET:CONFIG:DHCPENABLED?
u	Get MAC Address	:ETHERNET:CONFIG:MAC?
v	Get Current Ethernet Configuration	:ETHERNET:CONFIG:LISTEN?
w	Enable / Disable Ethernet	:ETHERNET:CONFIG:ETHERNETENABLED:[state]
x	Check Ethernet Interface	:ETHERNET:CONFIG:ETHERNETENABLED?
y	Update Ethernet Settings	:ETHERNET:CONFIG:INIT

## 2.8 (a) - Set Static IP Address

Sets the IP address to be used by the attenuator for Ethernet communication when using static IP settings. DHCP must be disabled for this setting to apply, otherwise a dynamic IP address will be in use. Changes to the Ethernet configuration only take effect after the [Update Ethernet Settings](#) command has been issued.

### Requirements

Model Name	Serial Number	Firmware
RC4DAT-8G-95	Up to 11910159999	C8 or later
	From 12001010001	All
RC4DAT-6G-95	Up to 11910299999	C8 or later
	From 11910300001	All
RC4DAT-6G-60	Up to 12007129999	C8 or later
	From 12007130001	All
RC4DAT-6G-30	Up to 12007129999	C8 or later
	From 12007239999	All
RCDAT series	All	C8 or later
All Other Models	All	All

### Command Syntax

```
:ETHERNET:CONFIG:IP: [ip]
```

Variable	Description
[ip]	The static IP address to be used by the attenuator; must be valid and available on the network

### Return String

```
[status]
```

Variable	Value	Description
[status]	0	Command failed
	1	Command completed successfully

### Examples

String to Send	String Returned
:ETHERNET:CONFIG:IP:192.100.1.1	1

HTTP Implementation:

```
http://10.10.10.10/:ETHERNET:CONFIG:IP:192.100.1.1
```

### See Also

[Get Static IP Address](#)  
[Set Static Subnet Mask](#)  
[Set Static Network Gateway](#)  
[Update Ethernet Settings](#)

## 2.8 (b) - Get Static IP Address

Returns the IP address to be used by the attenuator for Ethernet communication when static IP settings are in use. DHCP must be disabled for this setting to apply, otherwise a dynamic IP address will be in use.

### Requirements

Model Name	Serial Number	Firmware
RC4DAT-8G-95	Up to 11910159999	C8 or later
	From 12001010001	All
RC4DAT-6G-95	Up to 11910299999	C8 or later
	From 11910300001	All
RC4DAT-6G-60	Up to 12007129999	C8 or later
	From 12007130001	All
RC4DAT-6G-30	Up to 12007129999	C8 or later
	From 12007239999	All
RCDAT series	All	C8 or later
All Other Models	All	All

### Command Syntax

`:ETHERNET:CONFIG:IP?`

### Return String

`[ip]`

Variable	Description
<code>[ip]</code>	The static IP address to be used by the attenuator

### Examples

String to Send	String Returned
<code>:ETHERNET:CONFIG:IP?</code>	<code>192.100.1.1</code>

HTTP Implementation:

`http://10.10.10.10/:ETHERNET:CONFIG:IP?`

### See Also

- [Set Static IP Address](#)
- [Get Static Subnet Mask](#)
- [Get Static Network Gateway](#)
- [Get Current Ethernet Configuration](#)

## 2.8 (c) - Set Static Subnet Mask

Sets the subnet mask to be used by the attenuator for Ethernet communication when using static IP settings. DHCP must be disabled for this setting to apply, otherwise a dynamic IP address will be in use. Changes to the Ethernet configuration only take effect after the [Update Ethernet Settings](#) command has been issued.

### Requirements

Model Name	Serial Number	Firmware
RC4DAT-8G-95	Up to 11910159999	C8 or later
	From 12001010001	All
RC4DAT-6G-95	Up to 11910299999	C8 or later
	From 11910300001	All
RC4DAT-6G-60	Up to 12007129999	C8 or later
	From 12007130001	All
RC4DAT-6G-30	Up to 12007129999	C8 or later
	From 12007239999	All
RCDAT series	All	C8 or later
All Other Models	All	All

### Command Syntax

```
:ETHERNET:CONFIG:SM: [mask]
```

Variable	Description
[mask]	The subnet mask for communication on the network

### Return String

```
[status]
```

Variable	Value	Description
[status]	0	Command failed
	1	Command completed successfully

### Examples

String to Send	String Returned
<b>:ETHERNET:CONFIG:SM:255.255.255.0</b>	1

HTTP Implementation:

```
http://10.10.10.10/:ETHERNET:CONFIG:SM:255.255.255.0
```

### See Also

[Set Static IP Address](#)  
[Get Static Subnet Mask](#)  
[Set Static Network Gateway](#)  
[Update Ethernet Settings](#)

## 2.8 (d) - Get Static Subnet Mask

Returns the subnet mask to be used by the attenuator for Ethernet communication when static IP settings are in use. DHCP must be disabled for this setting to apply, otherwise a dynamic IP address will be in use.

### Requirements

Model Name	Serial Number	Firmware
RC4DAT-8G-95	Up to 11910159999	C8 or later
	From 12001010001	All
RC4DAT-6G-95	Up to 11910299999	C8 or later
	From 11910300001	All
RC4DAT-6G-60	Up to 12007129999	C8 or later
	From 12007130001	All
RC4DAT-6G-30	Up to 12007129999	C8 or later
	From 12007239999	All
RCDAT series	All	C8 or later
All Other Models	All	All

### Command Syntax

`:ETHERNET:CONFIG:SM?`

### Return String

`[mask]`

Variable	Description
<code>[mask]</code>	The subnet mask for communication on the network

### Examples

String to Send	String Returned
<code>:ETHERNET:CONFIG:SM?</code>	<code>255.255.255.0</code>

HTTP Implementation:

`http://10.10.10.10/:ETHERNET:CONFIG:SM?`

### See Also

- [Get Static IP Address](#)
- [Set Static Subnet Mask](#)
- [Get Static Network Gateway](#)
- [Get Current Ethernet Configuration](#)

## 2.8 (e) - Set Static Network Gateway

Sets the IP address of the network gateway to be used by the attenuator for Ethernet communication when using static IP settings. DHCP must be disabled for this setting to apply, otherwise a dynamic IP address will be in use. Changes to the Ethernet configuration only take effect after the [Update Ethernet Settings](#) command has been issued.

### Requirements

Model Name	Serial Number	Firmware
RC4DAT-8G-95	Up to 11910159999	C8 or later
	From 12001010001	All
RC4DAT-6G-95	Up to 11910299999	C8 or later
	From 11910300001	All
RC4DAT-6G-60	Up to 12007129999	C8 or later
	From 12007130001	All
RC4DAT-6G-30	Up to 12007129999	C8 or later
	From 12007239999	All
RCDAT series	All	C8 or later
All Other Models	All	All

### Command Syntax

`:ETHERNET:CONFIG:NG:[gateway]`

Variable	Description
<code>[gateway]</code>	IP address of the network gateway

### Return String

`[status]`

Variable	Value	Description
<code>[status]</code>	0	Command failed
	1	Command completed successfully

### Examples

String to Send	String Returned
<code>:ETHERNET:CONFIG:NG:192.100.1.0</code>	1

HTTP Implementation:

<http://10.10.10.10/:ETHERNET:CONFIG:NG:192.168.100.1.0>

### See Also

[Set Static IP Address](#)  
[Set Static Subnet Mask](#)  
[Get Static Network Gateway](#)  
[Update Ethernet Settings](#)

## 2.8 (f) - Get Static Network Gateway

Returns the IP address of the network gateway to be used by the attenuator for Ethernet communication when static IP settings are in use. DHCP must be disabled for this setting to apply, otherwise a dynamic IP address will be in use.

### Requirements

Model Name	Serial Number	Firmware
RC4DAT-8G-95	Up to 11910159999	C8 or later
	From 12001010001	All
RC4DAT-6G-95	Up to 11910299999	C8 or later
	From 11910300001	All
RC4DAT-6G-60	Up to 12007129999	C8 or later
	From 12007130001	All
RC4DAT-6G-30	Up to 12007129999	C8 or later
	From 12007239999	All
RCDAT series	All	C8 or later
All Other Models	All	All

### Command Syntax

`:ETHERNET:CONFIG:NG?`

### Return String

`[gateway]`

Variable	Description
<code>[gateway]</code>	IP address of the network gateway

### Examples

String to Send	String Returned
<code>:ETHERNET:CONFIG:NG?</code>	<code>192.168.1.0</code>

HTTP Implementation:

`http://10.10.10.10/:ETHERNET:CONFIG:NG?`

### See Also

- [Get Static IP Address](#)
- [Get Static Subnet Mask](#)
- [Set Static Network Gateway](#)
- [Get Current Ethernet Configuration](#)

## 2.8 (g) - Set HTTP Port

Sets the IP port to be used for HTTP communication. Changes to the Ethernet configuration only take effect after the [Update Ethernet Settings](#) command has been issued.

### Requirements

Model Name	Serial Number	Firmware
RC4DAT-8G-95	Up to 11910159999	C8 or later
	From 12001010001	All
RC4DAT-6G-95	Up to 11910299999	C8 or later
	From 11910300001	All
RC4DAT-6G-60	Up to 12007129999	C8 or later
	From 12007130001	All
RC4DAT-6G-30	Up to 12007129999	C8 or later
	From 12007239999	All
RCDAT series	All	C8 or later
All Other Models	All	All

### Command Syntax

`:ETHERNET:CONFIG:HTPORT:[port]`

Variable	Description
<code>[port]</code>	IP port to be used for HTTP communication. The port will need to be included in all HTTP commands if any other than the default port 80 is selected.

### Return String

`[status]`

Variable	Value	Description
<code>[status]</code>	0	Command failed
	1	Command completed successfully

### Examples

String to Send	String Returned
<code>:ETHERNET:CONFIG:HTPORT:8080</code>	1

HTTP Implementation:

`http://10.10.10.10/:ETHERNET:CONFIG:HTPORT:8080`

### See Also

- [Get HTTP Port](#)
- [Set Telnet Port](#)
- [Update Ethernet Settings](#)

## 2.8 (h) - Get HTTP Port

Gets the IP port to be used for HTTP communication.

### Requirements

Model Name	Serial Number	Firmware
RC4DAT-8G-95	Up to 11910159999	C8 or later
	From 12001010001	All
RC4DAT-6G-95	Up to 11910299999	C8 or later
	From 11910300001	All
RC4DAT-6G-60	Up to 12007129999	C8 or later
	From 12007130001	All
RC4DAT-6G-30	Up to 12007129999	C8 or later
	From 12007239999	All
RCDAT series	All	C8 or later
All Other Models	All	All

### Command Syntax

```
:ETHERNET:CONFIG:HTPORT?
```

### Return String

```
[port]
```

Variable	Description
<b>[port]</b>	IP port to be used for HTTP communication

### Examples

String to Send	String Returned
<b>:ETHERNET:CONFIG:HTPORT?</b>	<b>8080</b>

HTTP Implementation:

```
http://10.10.10.10/:ETHERNET:CONFIG:HTPORT?
```

### See Also

[Set HTTP Port](#)  
[Get Telnet Port](#)

## 2.8 (i) - Set Telnet Port

Sets the IP port to be used for Telnet communication. Changes to the Ethernet configuration only take effect after the [Update Ethernet Settings](#) command has been issued.

### Requirements

Model Name	Serial Number	Firmware
RC4DAT-8G-95	Up to 11910159999	C8 or later
	From 12001010001	All
RC4DAT-6G-95	Up to 11910299999	C8 or later
	From 11910300001	All
RC4DAT-6G-60	Up to 12007129999	C8 or later
	From 12007130001	All
RC4DAT-6G-30	Up to 12007129999	C8 or later
	From 12007239999	All
RCDAT series	All	C8 or later
All Other Models	All	All

### Command Syntax

`:ETHERNET:CONFIG:TELNETPORT:[port]`

Variable	Description
<code>[port]</code>	IP port to be used for Telnet communication. The port will need to be included when initiating a Telnet session if other than the default port 23 is selected.

### Return String

`[status]`

Variable	Value	Description
<code>[status]</code>	0	Command failed
	1	Command completed successfully

### Examples

String to Send	String Returned
<code>:ETHERNET:CONFIG:TELNETPORT:21</code>	1

HTTP Implementation:

`http://10.10.10.10/:ETHERNET:CONFIG:TELNETPORT:21`

### See Also

[Set HTTP Port](#)  
[Get Telnet Port](#)  
[Update Ethernet Settings](#)

## 2.8 (j) - Get Telnet Port

Gets the IP port to be used for Telnet communication.

### Requirements

Model Name	Serial Number	Firmware
RC4DAT-8G-95	Up to 11910159999	C8 or later
	From 12001010001	All
RC4DAT-6G-95	Up to 11910299999	C8 or later
	From 11910300001	All
RC4DAT-6G-60	Up to 12007129999	C8 or later
	From 12007130001	All
RC4DAT-6G-30	Up to 12007129999	C8 or later
	From 12007239999	All
RCDAT series	All	C8 or later
All Other Models	All	All

### Command Syntax

```
:ETHERNET:CONFIG:TELNETPORT?
```

### Return String

```
[port]
```

Variable	Description
[port]	IP port to be used for Telnet communication

### Examples

String to Send	String Returned
<b>:ETHERNET:CONFIG:TELNETPORT?</b>	<b>1</b>

HTTP Implementation:

```
http://10.10.10.10/:ETHERNET:CONFIG:TELNETPORT?
```

### See Also

[Get HTTP Port](#)  
[Set Telnet Port](#)

## 2.8 (k) - Enable Custom Telnet Prompt

When enabled, a custom text string will be returned as a prompt when the attenuator is ready to receive the next Telnet command. The custom prompt is disabled by default so only a new line character is returned. Changes to the Ethernet configuration only take effect after the [Update Ethernet Settings](#) command has been issued.

### Requirements

Model Name	Serial Number	Firmware
RC4DAT-8G-95	Up to 11910159999	C8 or later
	From 12001010001	All
RC4DAT-6G-95	Up to 11910299999	C8 or later
	From 11910300001	All
RC4DAT-6G-60	Up to 12007129999	C8 or later
	From 12007130001	All
RC4DAT-6G-30	Up to 12007129999	C8 or later
	From 12007239999	All
RCDAT series	All	C8 or later
All Other Models	All	All

### Command Syntax

`:ETHERNET:CONFIG:TELNETPROMPTENABLED:[state]`

Variable	Value	Description
[state]	0	Custom Telnet prompt disabled (new line character will be returned)
	1	Custom Telnet prompt enabled (see <a href="#">Set Custom Telnet Prompt Text</a> to set the text)

### Return String

[status]

Variable	Value	Description
[status]	0	Command failed
	1	Command completed successfully

### Examples

String to Send	String Returned
<code>:ETHERNET:CONFIG:TELNETPROMPTENABLED:0</code>	1
<code>:ETHERNET:CONFIG:TELNETPROMPTENABLED:1</code>	1

HTTP Implementation:

<http://10.10.10.10/:ETHERNET:CONFIG:TELNETPROMPTENABLED:1>

### See Also

[Query Telnet Prompt Type](#)  
[Set Custom Telnet Prompt Text](#)  
[Get Custom Telnet Prompt Text](#)  
[Update Ethernet Settings](#)

## 2.8 (I) - Query Telnet Prompt Type

Indicates whether the custom Telnet prompt is enabled. When enabled, a custom text string will be returned as a prompt when the attenuator is ready to receive the next Telnet command. The custom prompt is disabled by default so only a new line character is returned.

### Requirements

Model Name	Serial Number	Firmware
RC4DAT-8G-95	Up to 11910159999	C8 or later
	From 12001010001	All
RC4DAT-6G-95	Up to 11910299999	C8 or later
	From 11910300001	All
RC4DAT-6G-60	Up to 12007129999	C8 or later
	From 12007130001	All
RC4DAT-6G-30	Up to 12007129999	C8 or later
	From 12007239999	All
RCDAT series	All	C8 or later
All Other Models	All	All

### Command Syntax

`:ETHERNET:CONFIG:TELNETPROMPTENABLED?`

### Return String

`[STATE]`

Variable	Value	Description
<code>[state]</code>	0	Custom Telnet prompt disabled (new line character will be returned)
	1	Custom Telnet prompt enabled (see <a href="#">Set Custom Telnet Prompt Text</a> to set the text)

### Examples

String to Send	String Returned
<code>:ETHERNET:CONFIG:TELNETPROMPTENABLED?</code>	1

HTTP Implementation:

`http://10.10.10.10/:ETHERNET:CONFIG:TELNETPROMPTENABLED?`

### See Also

[Enable Custom Telnet Prompt](#)  
[Set Custom Telnet Prompt Text](#)  
[Get Custom Telnet Prompt Text](#)

## 2.8 (m) - Set Custom Telnet Prompt Text

Sets the text string (up to 10 characters) which will be used as a Telnet prompt when the custom prompt is enabled. Changes to the Ethernet configuration only take effect after the [Update Ethernet Settings](#) command has been issued.

### Requirements

Model Name	Serial Number	Firmware
RC4DAT-8G-95	Up to 11910159999	C8 or later
	From 12001010001	All
RC4DAT-6G-95	Up to 11910299999	C8 or later
	From 11910300001	All
RC4DAT-6G-60	Up to 12007129999	C8 or later
	From 12007130001	All
RC4DAT-6G-30	Up to 12007129999	C8 or later
	From 12007239999	All
RCDAT series	All	C8 or later
All Other Models	All	All

### Command Syntax

**:ETHERNET:CONFIG:TELNETPROMPTTEXT: [text]**

Variable	Description
[text]	A text string (up to 10 characters) to be used as a prompt during Telnet communication, or 1 of 2 special cases: 1. <b>MN</b> - The device's model name will be used 2. <b>SN</b> - The device's serial number will be used

### Return String

[status]

Variable	Value	Description
[status]	0	Command failed
	1	Command completed successfully

### Examples

String to Send	String Returned
:ETHERNET:CONFIG:TELNETPROMPTTEXT:MN	1
:ETHERNET:CONFIG:TELNETPROMPTTEXT:SN	1
:ETHERNET:CONFIG:TELNETPROMPTTEXT:RCDAT	1

HTTP Implementation: <http://10.10.10.10/:ETHERNET:CONFIG:TELNETPROMPTTEXT:RCDAT>

### See Also

- [Enable Custom Telnet Prompt](#)
- [Query Telnet Prompt Type](#)
- [Get Custom Telnet Prompt Text](#)
- [Update Ethernet Settings](#)

## 2.8 (n) - Get Custom Telnet Prompt Text

Returns the text string (up to 10 characters) which will be used as a Telnet prompt when the custom prompt is enabled.

### Requirements

Model Name	Serial Number	Firmware
RC4DAT-8G-95	Up to 11910159999	C8 or later
	From 12001010001	All
RC4DAT-6G-95	Up to 11910299999	C8 or later
	From 11910300001	All
RC4DAT-6G-60	Up to 12007129999	C8 or later
	From 12007130001	All
RC4DAT-6G-30	Up to 12007129999	C8 or later
	From 12007239999	All
RCDAT series	All	C8 or later
All Other Models	All	All

### Command Syntax

`:ETHERNET:CONFIG:TELNETPROMPTTEXT?`

### Return String

`[text]`

Variable	Description
<code>[text]</code>	The text string (up to 10 characters) to be used as a prompt during Telnet communication, or 1 of 2 special cases: <ol style="list-style-type: none"> <li><code>MN</code> - The device's model name will be used</li> <li><code>SN</code> - The device's serial number will be used</li> </ol>

### Examples

String to Send	String Returned
<code>:ETHERNET:CONFIG:TELNETPROMPTTEXT?</code>	<code>RCDAT</code>

HTTP Implementation:

`http://10.10.10.10/:ETHERNET:CONFIG:TELNETPROMPTTEXT?`

### See Also

[Enable Custom Telnet Prompt](#)  
[Query Telnet Prompt Type](#)  
[Set Custom Telnet Prompt Text](#)

## 2.8 (o) - Set Password Requirement

Sets whether or not a password is required for Ethernet communication. Changes to the Ethernet configuration only take effect after the [Update Ethernet Settings](#) command has been issued.

### Requirements

Model Name	Serial Number	Firmware
RC4DAT-8G-95	Up to 11910159999	C8 or later
	From 12001010001	All
RC4DAT-6G-95	Up to 11910299999	C8 or later
	From 11910300001	All
RC4DAT-6G-60	Up to 12007129999	C8 or later
	From 12007130001	All
RC4DAT-6G-30	Up to 12007129999	C8 or later
	From 12007239999	All
RCDAT series	All	C8 or later
All Other Models	All	All

### Command Syntax

`:ETHERNET:CONFIG:PWDENABLED:[enabled]`

Variable	Value	Description
<code>[enabled]</code>	0	Password not required for Ethernet communication
	1	Password required for Ethernet communication

### Return String

`[status]`

Variable	Value	Description
<code>[status]</code>	0	Command failed
	1	Command completed successfully

### Examples

String to Send	String Returned
<code>:ETHERNET:CONFIG:PWDENABLED:1</code>	1

HTTP Implementation:

<http://10.10.10.10/:ETHERNET:CONFIG:PWDENABLED:1>

### See Also

[Get Password Requirement](#)

[Set Password](#)

[Get Password](#)

[Update Ethernet Settings](#)

## 2.8 (p) - Get Password Requirement

Indicates whether or not a password is required for Ethernet communication.

### Requirements

Model Name	Serial Number	Firmware
RC4DAT-8G-95	Up to 11910159999	C8 or later
	From 12001010001	All
RC4DAT-6G-95	Up to 11910299999	C8 or later
	From 11910300001	All
RC4DAT-6G-60	Up to 12007129999	C8 or later
	From 12007130001	All
RC4DAT-6G-30	Up to 12007129999	C8 or later
	From 12007239999	All
RCDAT series	All	C8 or later
All Other Models	All	All

### Command Syntax

`:ETHERNET:CONFIG:PWDENABLED?`

### Return String

`[enabled]`

Variable	Value	Description
<code>[enabled]</code>	0	Password not required for Ethernet communication
	1	Password required for Ethernet communication

### Examples

String to Send	String Returned
<code>:ETHERNET:CONFIG:PWDENABLED?</code>	1

HTTP Implementation:

`http://10.10.10.10/:ETHERNET:CONFIG:PWDENABLED?`

### See Also

[Set Password Requirement](#)  
[Set Password](#)  
[Get Password](#)

## 2.8 (q) - Set Password

Sets the password for Ethernet communication. The password will only be required for communication with the device when password security is enabled. Changes to the Ethernet configuration only take effect after the [Update Ethernet Settings](#) command has been issued.

### Requirements

Model Name	Serial Number	Firmware
RC4DAT-8G-95	Up to 11910159999	C8 or later
	From 12001010001	All
RC4DAT-6G-95	Up to 11910299999	C8 or later
	From 11910300001	All
RC4DAT-6G-60	Up to 12007129999	C8 or later
	From 12007130001	All
RC4DAT-6G-30	Up to 12007129999	C8 or later
	From 12007239999	All
RCDAT series	All	C8 or later
All Other Models	All	All

### Command Syntax

`:ETHERNET:CONFIG:PWD:[pwd]`

Variable	Description
[pwd]	Password to set for Ethernet communication (not case sensitive)

### Return String

`[status]`

Variable	Value	Description
[status]	0	Command failed
	1	Command completed successfully

### Examples

String to Send	String Returned
<code>:ETHERNET:CONFIG:PWD:PASS-123</code>	1

HTTP Implementation:

<http://10.10.10.10/:ETHERNET:CONFIG:PWD:PASS-123>

### See Also

[Set Password Requirement](#)  
[Get Password Requirement](#)  
[Get Password](#)  
[Update Ethernet Settings](#)

## 2.8 (r) - Get Password

Returns the password for Ethernet communication. The password will only be required for communication with the device when password security is enabled

### Requirements

Model Name	Serial Number	Firmware
RC4DAT-8G-95	Up to 11910159999	C8 or later
	From 12001010001	All
RC4DAT-6G-95	Up to 11910299999	C8 or later
	From 11910300001	All
RC4DAT-6G-60	Up to 12007129999	C8 or later
	From 12007130001	All
RC4DAT-6G-30	Up to 12007129999	C8 or later
	From 12007239999	All
RCDAT series	All	C8 or later
All Other Models	All	All

### Command Syntax

`:ETHERNET:CONFIG:PWD?`

### Return String

`[pwd]`

Variable	Description
<code>[pwd]</code>	Password for Ethernet communication (not case sensitive)

### Examples

String to Send	String Returned
<code>:ETHERNET:CONFIG:PWD?</code>	<code>PASS-123</code>

HTTP Implementation:

<http://10.10.10.10/:ETHERNET:CONFIG:PWD?>

### See Also

[Set Password Requirement](#)  
[Get Password Requirement](#)  
[Set Password](#)

## 2.8 (s) - Set DHCP Status

Enables or disables DHCP (Dynamic Host Control Protocol). When enabled the attenuator will request a valid IP address from the network's DHCP server. When disabled, the attenuator's static IP settings will be used. Changes to the Ethernet configuration only take effect after the [Update Ethernet Settings](#) command has been issued.

### Requirements

Model Name	Serial Number	Firmware
RC4DAT-8G-95	Up to 11910159999	C8 or later
	From 12001010001	All
RC4DAT-6G-95	Up to 11910299999	C8 or later
	From 11910300001	All
RC4DAT-6G-60	Up to 12007129999	C8 or later
	From 12007130001	All
RC4DAT-6G-30	Up to 12007129999	C8 or later
	From 12007239999	All
RCDAT series	All	C8 or later
All Other Models	All	All

### Command Syntax

`:ETHERNET:CONFIG:DHCPENABLED:[enabled]`

Variable	Value	Description
<code>[enabled]</code>	0	DHCP disabled (static IP settings will be used)
	1	DHCP enabled (IP address will be requested from DHCP server on the network)

### Return String

`[status]`

Variable	Value	Description
<code>[status]</code>	0	Command failed
	1	Command completed successfully

### Examples

String to Send	String Returned
<code>:ETHERNET:CONFIG:DHCPENABLED:1</code>	1

HTTP Implementation:

`http://10.10.10.10/:ETHERNET:CONFIG:DHCPENABLED:1`

### See Also

[Set Static IP Address](#)

[Get DHCP Status](#)

[Update Ethernet Settings](#)

## 2.8 (t) - Get DHCP Status

Indicates whether or not DHCP (Dynamic Host Control Protocol) is enabled. When enabled the attenuator will request a valid IP address from the network's DHCP server. When disabled, the attenuator's static IP settings will be used.

### Requirements

Model Name	Serial Number	Firmware
RC4DAT-8G-95	Up to 11910159999	C8 or later
	From 12001010001	All
RC4DAT-6G-95	Up to 11910299999	C8 or later
	From 11910300001	All
RC4DAT-6G-60	Up to 12007129999	C8 or later
	From 12007130001	All
RC4DAT-6G-30	Up to 12007129999	C8 or later
	From 12007239999	All
RCDAT series	All	C8 or later
All Other Models	All	All

### Command Syntax

**:ETHERNET:CONFIG:DHCPENABLED?**

### Return String

**[enabled]**

Variable	Value	Description
[enabled]	0	DHCP disabled (static IP settings will be used)
	1	DHCP enabled (IP address will be requested from DHCP server on the network)

### Examples

String to Send	String Returned
<b>:ETHERNET:CONFIG:DHCPENABLED?</b>	<b>1</b>

HTTP Implementation:

<http://10.10.10.10/:ETHERNET:CONFIG:DHCPENABLED?>

### See Also

- [Set Static IP Address](#)
- [Set DHCP Status](#)
- [Get Current Ethernet Configuration](#)

## 2.8 (u) - Get MAC Address

Returns the MAC (Media Access Control) address of the attenuator (a physical hardware address).

### Requirements

Model Name	Serial Number	Firmware
RC4DAT-8G-95	Up to 11910159999	C8 or later
	From 12001010001	All
RC4DAT-6G-95	Up to 11910299999	C8 or later
	From 11910300001	All
RC4DAT-6G-60	Up to 12007129999	C8 or later
	From 12007130001	All
RC4DAT-6G-30	Up to 12007129999	C8 or later
	From 12007239999	All
RCDAT series	All	C8 or later
All Other Models	All	All

### Command Syntax

`:ETHERNET:CONFIG:MAC?`

### Return String

`[mac]`

Variable	Description
<code>[mac]</code>	MAC address of the attenuator

### Examples

String to Send	String Returned
<code>:ETHERNET:CONFIG:MAC?</code>	<code>D0-73-7F-82-D8-01</code>

HTTP Implementation:

<http://10.10.10.10/:ETHERNET:CONFIG:MAC?>

### See Also

- [Get Static IP Address](#)
- [Get Static Subnet Mask](#)
- [Get Static Network Gateway](#)
- [Get Current Ethernet Configuration](#)

## 2.8 (v) - Get Current Ethernet Configuration

Returns the Ethernet configuration (IP address, subnet mask and network gateway) that is currently active for the device. If DHCP is enabled this will be the settings issued dynamically by the network's DHCP server. If DHCP is disabled this will be the user configured static IP settings.

### Requirements

Model Name	Serial Number	Firmware
RC4DAT-8G-95	Up to 11910159999	C8 or later
	From 12001010001	All
RC4DAT-6G-95	Up to 11910299999	C8 or later
	From 11910300001	All
RC4DAT-6G-60	Up to 12007129999	C8 or later
	From 12007130001	All
RC4DAT-6G-30	Up to 12007129999	C8 or later
	From 12007239999	All
RCDAT series	All	C8 or later
All Other Models	All	All

### Command Syntax

**:ETHERNET:CONFIG:LISTEN?**

### Return String

**[ip]; [mask]; [gateway]**

Variable	Description
[ip]	Active IP address of the device
[mask]	Subnet mask for the network
[gateway]	IP address of the network gateway

### Examples

String to Send	String Returned
<b>:ETHERNET:CONFIG:LISTEN?</b>	<b>192.100.1.1;255.255.255.0;192.100.1.0</b>

HTTP Implementation:

<http://10.10.10.10/:ETHERNET:CONFIG:LISTEN?>

### See Also

- [Get Static IP Address](#)
- [Get Static Subnet Mask](#)
- [Get Static Network Gateway](#)
- [Update Ethernet Settings](#)

## 2.8 (w) - Enable / Disable Ethernet Interface

Enables or disables the Ethernet interface. Disabling the Ethernet interface reduces current consumption but further communication would only be possible by USB. Changes to the Ethernet configuration only take effect after the [Update Ethernet Settings](#) command has been issued.

### Requirements

RCDAT-30G-30 / RCDAT-40G-30 / RCDAT-6G-120H / RC4DAT-8G-120H

### Command Syntax

`:ETHERNET:CONFIG:ETHERNETENABLED:[state]`

Variable	Value	Description
[state]	0	Ethernet interface disabled
	1	Ethernet interface enabled

### Return String

`[status]`

Variable	Value	Description
[status]	0	Command failed
	1	Command completed successfully

### Examples

String to Send	String Returned
<code>:01:ETHERNET:CONFIG:ETHERNETENABLED:0</code>	1
<code>:02:ETHERNET:CONFIG:ETHERNETENABLED:0</code>	1

HTTP Implementation:

<http://10.10.10.10/:01:ETHERNET:CONFIG:ETHERNETENABLED:0>

### See Also

[Check Ethernet Interface](#)  
[Update Ethernet Settings](#)

## 2.8 (x) - Check Ethernet Interface

Indicates whether or not the Ethernet interface is enabled. When disabled, communication will only be possible with the USB connection to the attenuator.

### Requirements

RCDAT-30G-30 / RCDAT-40G-30 / RCDAT-6G-120H / RC4DAT-8G-120H

### Command Syntax

`:ETHERNET:CONFIG:ETHERNETENABLED?`

### Return String

`[state]`

Variable	Value	Description
<code>[state]</code>	0	Ethernet interface disabled
	1	Ethernet interface enabled

### Examples

String to Send	String Returned
<code>:ETHERNET:CONFIG:ETHERNETENABLED?</code>	1

HTTP Implementation:

`http://10.10.10.10/:ETHERNET:CONFIG:ETHERNETENABLED?`

### See Also

[Enable / Disable Ethernet Interface](#)

## 2.8 (y) - Update Ethernet Settings

Resets the Ethernet controller so that any recently applied changes to the Ethernet configuration can be loaded. Any subsequent commands / queries to the attenuator will need to be issued using the new Ethernet configuration.

Note: If a connection cannot be established after the INIT command has been issued it may indicate that an invalid configuration was created (for example a static IP address which clashes with another device on the network). The Ethernet settings can always be overwritten by connecting to the system using the USB connection.

### Requirements

Model Name	Serial Number	Firmware
RC4DAT-8G-95	Up to 11910159999	C8 or later
	From 12001010001	All
RC4DAT-6G-95	Up to 11910299999	C8 or later
	From 11910300001	All
RC4DAT-6G-60	Up to 12007129999	C8 or later
	From 12007130001	All
RC4DAT-6G-30	Up to 12007129999	C8 or later
	From 12007239999	All
RCDAT series	All	C8 or later
All Other Models	All	All

### Command Syntax

**:ETHERNET:CONFIG:INIT**

### Return String

[status]

Variable	Value	Description
[status]	0	Command failed
	1	Command completed successfully

### Examples

String to Send	String Returned
:ETHERNET:CONFIG:INIT	1

HTTP Implementation:

<http://10.10.10.10/:ETHERNET:CONFIG:INIT>

### See Also

[Get Current Ethernet Configuration](#)

## 3 - Ethernet Control API

Control of the system via Ethernet TCP / IP networks involves sending the SCPI commands / queries detailed above via HTTP or Telnet. SSH is also available as an option on some models for secure communication (please contact [testsolutions@minicircuits.com](mailto:testsolutions@minicircuits.com) for details).

In addition, UDP is supported for discovering available systems on the network.

These protocols are widely supported and straightforward to implement in most programming environments. Any Internet browser can be used as a console / tester for HTTP control by typing the full URL directly into the address bar. Telnet and SSH are supported by a number of console applications, including PuTTY.

### 3.1 - Configuring Ethernet Settings

The device can be configured manually with a static IP address or automatically by the network using DHCP (Dynamic Host Control Protocol):

- Dynamic IP (factory default setting)
  - Subnet Mask, Network Gateway and local IP Address are assigned by the network server on each connection
  - The only user controllable parameters are:
    - TCP/IP Port for HTTP communication (the default is port 80)
    - SSH port, default is port 22
    - Telnet port, default is port 23
    - Password (up to 20 characters; default is no password)
- Static IP
  - All parameters must be specified by the user:
    - IP Address (must be a legal and unique address on the local network)
    - Subnet Mask (subnet mask of the local network)
    - Network gateway (the IP address of the network gateway/router)
    - TCP/IP port (used for HTTP communication), default is port 80
    - SSH port, default is port 22
    - Telnet port, default is port 23
    - Password (up to 20 characters; default is no password)

## 3.2 - HTTP Communication

The basic format of the HTTP command to set the attenuator is:

<http://ADDRESS:PORT/PWD;COMMAND>

Where

- `http://` is required
- ADDRESS = IP address (required)
- PORT = TCP/IP port (can be omitted if port 80 is used)
- PWD = Password (can be omitted if password security is not enabled)
- COMMAND = Command to send to the attenuator

Example 1:

<http://192.168.100.100:800/PWD=123;SETATT=10.25>

Explanation:

- The attenuator has IP address 192.168.100.100 and uses port 800
- Password security is enabled and set to “123”
- The command is to set the attenuation to 10.25dB (see below for the full explanation of all commands/queries)

Example 2:

<http://10.10.10.10/SETATT=0>

Explanation:

- The attenuator has IP address 10.10.10.10 and uses the default port 80
- Password security is disabled
- The command is to set the attenuation to 0dB (see below for the full explanation of all commands/queries)

## 3.3 - SSH Communication

Note: SSH communication is not supported as standard on all models, please contact [testsolutions@minicircuits.com](mailto:testsolutions@minicircuits.com) for details.

SSH allows secure communication with the system, using the configured SSH port (default is port 22) and password. The user name is `ssh_user`.

SSH is widely supported and can be implemented in most programming environments. Alternatively, a client such as PuTTY can be used as a console to quickly establish an SSH connection and control the system.

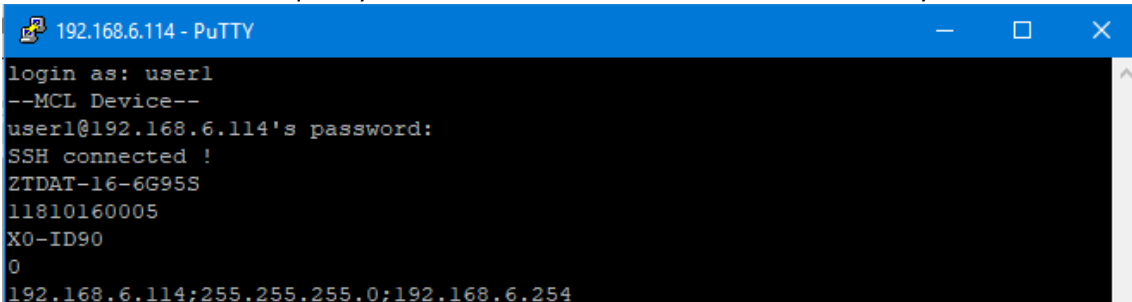

```
192.168.6.114 - PuTTY
login as: user1
--MCL Device--
user1@192.168.6.114's password:
SSH connected !
ZTDAT-16-6G95S
11810160005
X0-ID90
0
192.168.6.114;255.255.255.0;192.168.6.254
```

### 3.4 - Telnet Communication

Communication is started by creating a Telnet connection to the system's IP address. On successful connection the "line feed" character will be returned. If the system has a password enabled then this must be sent as the first command after connection.

Each command must be terminated with the carriage return and line-feed characters (\r\n). Responses will be similarly terminated. A basic example of the Telnet communication structure using the Windows Telnet Client is summarized below:

- 1) Set up Telnet connection to an attenuator with IP address 192.168.9.73

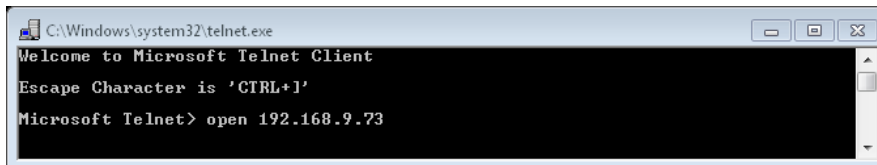

```

C:\Windows\system32\telnet.exe
Welcome to Microsoft Telnet Client
Escape Character is 'CTRL+I'
Microsoft Telnet> open 192.168.9.73
    
```

- 2) The "line feed" character is returned indicating the connection was successful:



```

Telnet 192.168.9.73
-
    
```

- 3) The password (if enabled) must be sent as the first command; a return value of 1 indicates success:



```

Telnet 192.168.9.73
PWD=123
1
    
```

- 4) Any number of commands and queries can be sent as needed:

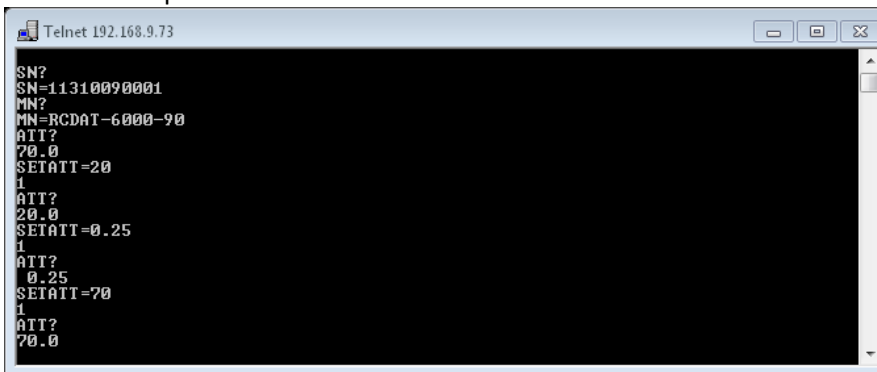

```

Telnet 192.168.9.73
SN?
SN=11310090001
MN?
MN=RCDAT-6000-90
ATT?
70.0
SETATT=20
I
ATT?
20.0
SETATT=0.25
I
ATT?
0.25
SETATT=70
I
ATT?
70.0
    
```

The below example demonstrates the communication when a custom Telnet prompt has been enabled. In this case the user set the prompt as "SN" which means the device's serial number is used. The attenuator therefore responds with 11406170049> (the serial number of the specific device under test) when it is ready to receive the next communication:

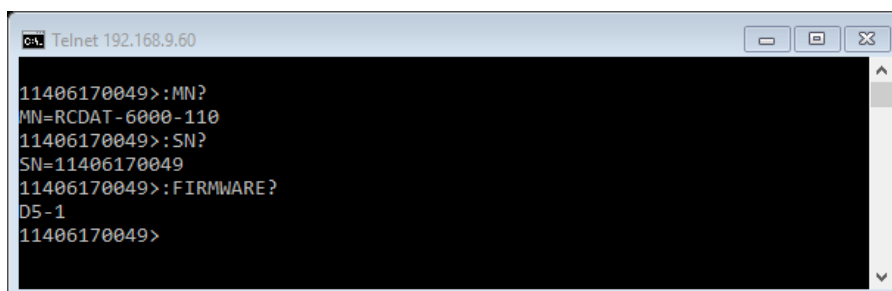

```

Telnet 192.168.9.60
11406170049>:MN?
MN=RCDAT-6000-110
11406170049>:SN?
SN=11406170049
11406170049>:FIRMWARE?
D5-1
11406170049>
    
```

### 3.5 - Device Discovery Using UDP

Limited support of UDP is provided for the purpose of “device discovery.” This allows a user to request the IP address and configuration of all Mini-Circuits multi-channel attenuator systems connected on the network; full control of those units is then accomplished using SSH, HTTP or Telnet, as detailed previously.

Alternatively, the IP configuration can be identified or changed by connecting the attenuator with the USB interface (see [Configuring Ethernet Settings](#)).

Note: UDP is a simple transmission protocol that provides no method for error correction or guarantee of receipt.

#### UDP Ports

Mini-Circuits’ programmable attenuators are configured to listen on UDP port 4950 and answer on UDP port 4951. Communication on these ports must be allowed through the computer’s firewall in order to use UDP for device discovery. If the attenuator’s IP address is already known it is not necessary to use UDP.

#### Transmission

The command [MCLDAT?](#) should be broadcast to the local network using UDP protocol on port 4950.

#### Receipt

All Mini-Circuits programmable attenuators that receive the request will respond with the following information (each field separated by CrLf) on port 4951:

- Model Name
- Serial Number
- IP Address/Port
- Subnet Mask
- Network Gateway
- MAC Address

#### Example

Sent Data:

[MCLDAT?](#)

Received Data:

```
Model Name: RCDAT-6000-60
Serial Number: 11302120001
IP Address=192.168.9.101 Port: 80
Subnet Mask=255.255.0.0
Network Gateway=192.168.9.0
Mac Address=D0-73-7F-82-D8-01
```

```
Model Name: RCDAT-6000-60
Serial Number: 11302120002
IP Address=192.168.9.102 Port: 80
Subnet Mask=255.255.0.0
Network Gateway=192.168.9.0
Mac Address=D0-73-7F-82-D8-02
```

## 4 - USB Control API for Microsoft Windows

Mini-Circuits' API for USB control from a computer running Microsoft Windows is provided in the form of a DLL file. 3 DLL options are provided to offer the widest possible support, with the same functionality in each case.

- 1) .Net Framework 4.5 DLL
  - a. This is the recommended API for most modern operating systems
- 2) .Net Framework 2.0 DLL
  - a. Provided for legacy support of older computers / operating systems, with an installed version of the .Net framework prior to 4.5
- 3) ActiveX com object
  - a. Provided for legacy support of older systems and programming environments which do not support .Net

The latest version of each DLL file can be downloaded from the Mini-Circuits website at:

<https://www.minicircuits.com/softwaredownload/patt.html>

### 4.1 - DLL API Options

#### 4.1 (a) - .NET Framework 4.5 DLL (Recommended)

The recommended API option for USB control from most modern programming environments running on Windows.

**Filename: mcl\_RUDAT\_NET45.dll**

##### Requirements

- 1) Microsoft Windows with .Net framework 4.5 or later
- 2) Programming environment with ability to support .Net components

##### Installation

- 1) Download the latest DLL file from the Mini-Circuits website
- 2) Copy the .dll file to the preferred directory (the recommendation is to use the same folder as the programming project, or C:\WINDOWS\SysWOW64
- 3) Right-click on the DLL file in the save location and select Properties to check that Windows has not blocked access to the file (check "Unblock" if the option is shown)
- 4) **No registration or further installation action is required**

#### 4.1 (b) - .NET Framework 2.0 DLL (Legacy Support)

Provided for support of systems with an older version of the .Net framework installed (prior to 4.5).

**Filename: mcl\_RUDAT64.dll**

##### Requirements

- 1) Microsoft Windows with .Net framework 2.0 or later
- 2) Programming environment with ability to support .Net components

##### Installation

- 1) Download the latest DLL file from the Mini-Circuits website:
- 2) Copy the .dll file to the preferred directory (the recommendation is to use the same folder as the programming project, or C:\WINDOWS\SysWOW64
- 3) Right-click on the DLL file in the save location and select Properties to check that Windows has not blocked access to the file (check "Unblock" if the option is shown)
- 4) **No registration or further installation action is required**

#### 4.1 (c) - ActiveX COM Object DLL (Legacy Support)

Provided for support of programming environments which do not support .Net components.

Filename: mcl\_RUDAT.dll

#### Requirements

- 1) Microsoft Windows
- 2) Programming environment with support for ActiveX components

#### Installation

1. Download the latest DLL file from the Mini-Circuits website
2. Copy the DLL file to the correct directory:
  - a. 32-bit PC: C:\WINDOWS\System32
  - b. 64-bit PC: C:\WINDOWS\SysWOW64
3. Open the Command Prompt:
  - a. For Windows XP®:
    - i. Select “All Programs” and then “Accessories” from the Start Menu
    - ii. Click on “Command Prompt” to open
  - b. For later Windows versions the Command Prompt will need to be run in “Elevated” mode (as an administrator):
    - i. Open the Start Menu/Start Screen and type “Command Prompt”
    - ii. Right-click on the shortcut for the Command Prompt
    - iii. Select “Run as Administrator”
    - iv. Enter the administrator credentials if requested
4. Use regsvr32 to register the DLL:
  - a. 32-bit PC: \WINDOWS\System32\Regsvr32 \WINDOWS\System32\mcl\_rudat.dll
  - b. 64-bit: \WINDOWS\SysWOW64\Regsvr32 \WINDOWS\SysWOW64\mcl\_rudat.dll
5. Hit enter to confirm and a message box will appear to advise of successful registration.

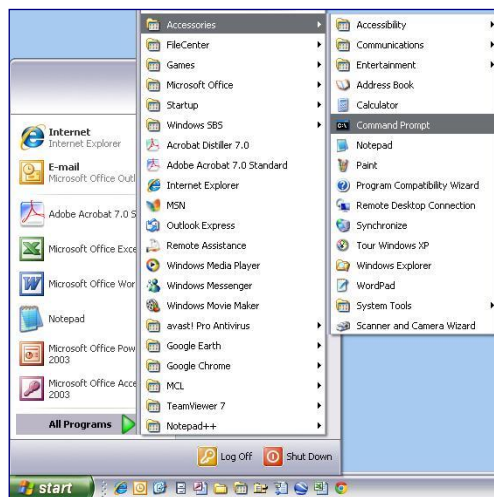

Fig 4.1-a: Opening the Command Prompt in Windows XP

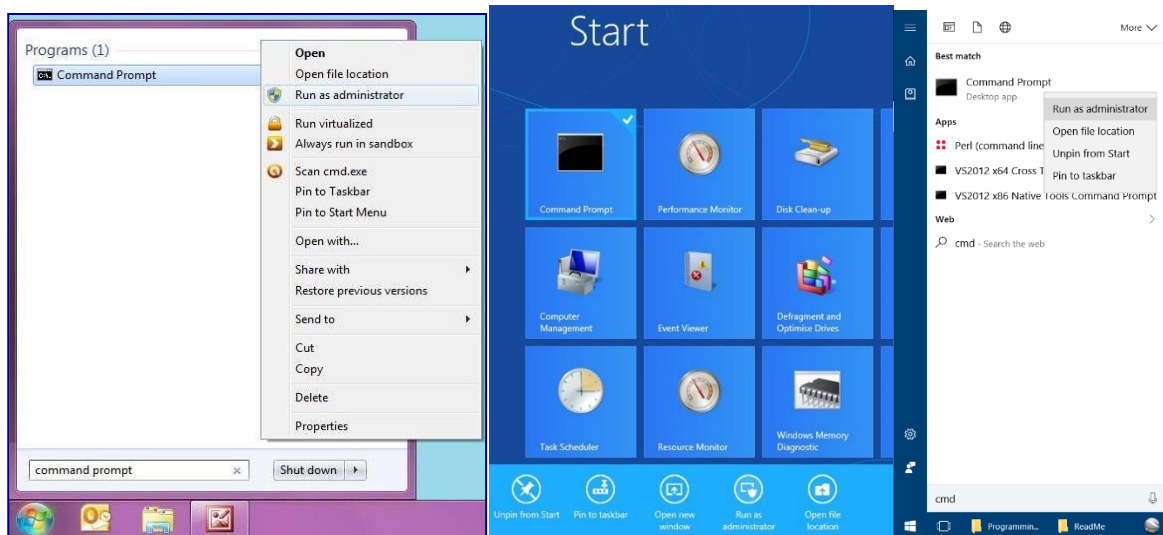

Fig 4.1-b: Opening the Command Prompt in Windows 7 (left), Windows 8 (middle) and Windows 10 (right)

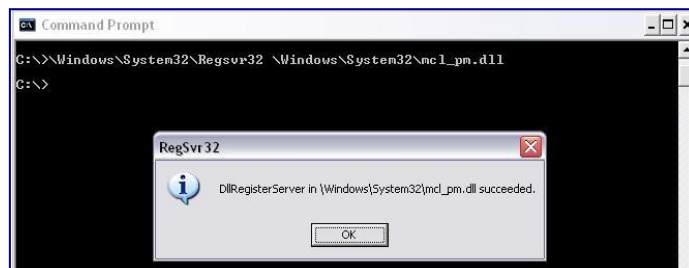

Fig 4.1-c: Registering the DLL in a 32-bit environment

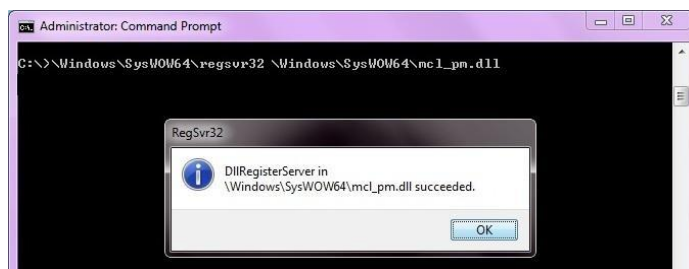

Fig 4.1-d: Registering the DLL in a 64-bit environment

## 4.2 - Referencing the DLL

Most programming environments require a reference to be set to the relevant DLL file, either in the IDE menu or within the program. Multiple instances of the DLL control class can then be created (referred to as MyPTE1 and MyPTE2 below) in order to connect to as many devices as needed

### Example Declarations Using the .NET 4.5 DLL (mcl\_RUDAT\_NET45.dll)

(For operation with the .Net 2.0 DLL, replace "mcl\_RUDAT\_NET45" with "mcl\_RUDAT64")

Python	<pre>import clr      # Import the pythonnet CLR library clr.AddReference('mcl_RUDAT_NET45') from mcl_RUDAT_NET45 import USB_RUDAT MyPTE1 = USB_RUDAT() MyPTE2 = USB_RUDAT()</pre>
Visual Basic	<pre>Public MyPTE1 As New mcl_RUDAT_NET45.USB_RUDAT Public MyPTE2 As New mcl_RUDAT_NET45.USB_RUDAT</pre>
Visual C++	<pre>mcl_RUDAT_NET45::USB_RUDAT ^MyPTE1 = gcnew mcl_RUDAT_NET45::USB_RUDAT(); mcl_RUDAT_NET45::USB_RUDAT ^MyPTE2 = gcnew mcl_RUDAT_NET45::USB_RUDAT();</pre>
Visual C#	<pre>mcl_RUDAT_NET45.USB_RUDAT MyPTE1 = new mcl_RUDAT_NET45.USB_RUDAT(); mcl_RUDAT_NET45.USB_RUDAT MyPTE2 = new mcl_RUDAT_NET45.USB_RUDAT();</pre>
MatLab	<pre>MCL_ATT = NET.addAssembly('C:\Windows\SysWOW64\mcl_RUDAT_NET45.dll') MyPTE1 = mcl_RUDAT_NET45.USB_RUDAT MyPTE2 = mcl_RUDAT_NET45.USB_RUDAT</pre>

### Example Declarations using the ActiveX DLL (mcl\_RUDAT.dll)

Visual Basic	<pre>Public MyPTE1 As New MCL_RUDAT.USB_DAT Public MyPTE2 As New MCL_RUDAT.USB_DAT</pre>
Visual C++	<pre>MCL_RUDAT::USB_DAT ^MyPTE1 = gcnew MCL_RUDAT::USB_DAT(); MCL_RUDAT::USB_DAT ^MyPTE2 = gcnew MCL_RUDAT::USB_DAT();</pre>
Visual C#	<pre>public MCL_RUDAT.USB_DAT MyPTE1 = new MCL_RUDAT.USB_DAT(); public MCL_RUDAT.USB_DAT MyPTE2 = new MCL_RUDAT.USB_DAT();</pre>
MatLab	<pre>MyPTE1 = actxserver(MCL_RUDAT.USB_DAT) MyPTE2 = actxserver(MCL_RUDAT.USB_DAT)</pre>

### 4.3 - Note on DLL Use in Python / MatLab

Some functions are defined within Mini-Circuits' DLLs with arguments to be passed by reference. This allows the variables (with their updated values) to be used later within the program, after the DLL function has executed. This methodology fits with many programming environments (including C#, C++ and VB) but is interpreted slightly differently by Python and MatLab:

- Typical operation (C#, C++, VB):
  - The function has an integer return value to indicate success / failure (1 or 0)
  - One or more variables are passed to the function by reference so that the updated values are available to the program once function execution has completed
- Python implementation:
  - Any parameters passed by reference to a function can be ignored (an empty string can be provided in place of the variable)
  - The return value from the function will change from the single integer value as defined in this manual, to a tuple
  - The tuple format will be [function\_return\_value, function\_parameter]
- MatLab implementation:
  - Any parameters passed by reference to a function can be ignored (an empty string can be provided in place of the variable)
  - The return value from the function will change from the single integer value as defined in this manual to an array of values
  - The function must be assigned to an array variable of the correct size, in the format [function\_return\_value, function\_parameter]

The examples below illustrate how a function of this type is defined in the DLL and how that same function is implemented in C#, Python and MatLab.

<b>Definition</b>	<code>int Read_SN(ByRef string SN)</code>
Visual C#	<pre>status = MyPTE1.Read_SN(ref(SN)); if(status &gt; 0) {     MessageBox.Show("The connected device is " + SN); }</pre>
Python	<pre>status = MyPTE1.Read_SN("") if status[0] &gt; 0:     SN = str(status[1])     print('The connected device is ', SN)</pre>
MatLab	<pre>[status, SN] = MyPTE1.Read_SN('') if status &gt; 0     h = msgbox('The connected device is ', SN) end</pre>

## 4.4 - DLL Function Definitions

The following functions are defined in both of the DLL files. Please see the following sections for a full description of their structure and implementation.

### 4.4 (a) - DLL Functions for USB Control

- a) int `Get_Available_SN_List`(ByRef string `SN_List`)
- b) int `Get_Available_Address_List`(ByRef string `Add_List`)
- c) int `Connect`(Optional string `SN`)
- d) int `ConnectByAddress`(Optional int `Address`)
- e) void `Disconnect`()
- f) int `Read_ModelName`(ByRef string `ModelName`)
- g) int `Read_SN`(ByRef string `SN`)
- h) int `Set_Address`(int `Address`)
- i) int `Get_Address`()
- j) int `Set_StartUpAttIndicator`(int `Indicator`)
- k) int `Get_StartUpAttIndicator`()
- l) int `InitiateStoreLastAtt`()
- m) int `Send_SCPI`(string `SndSTR`, ByRef string `RetSTR`)
- n) int `GetUSBConnectionStatus`()
- o) int `GetStatus`()
- p) int `GetExtFirmware`(ByRef int `A0`, ByRef int `A1`, ByRef int `A2`,  
ByRef string `Firmware`)

### 4.4 (b) - DLL Functions for ZVVA / RUDAT / RCDAT (Single Channel) Models

- a) int `SetAttenuation`(ByRef float `TotalAtt`) (ActiveX)  
int `SetAttenuation`(float `TotalAtt`) (.NET)
- b) int `Read_Att`(ByRef float `CAtt1`)
- c) int `Set_StartUpAtt`(single `AttVal`)
- d) single `Get_StartUpAtt`()

### 4.4 (c) - DLL Functions for RC4DAT & RC8DAT (Multi-Channel) Models

- a) int `SetChannelAtt`(int `Channel`, float `TotalAtt`)
- b) int `SetChannelsAtt`(float `Att1`, int `CH1`, int `CH2`,  
int `CH3`, int `CH4`)
- c) float `ReadChannelAtt`(int `Channel`)
- d) int `Read4ChannelsAtt`(ByRef float `C1Att`, ByRef float `C2Att`,  
ByRef float `C3Att`, ByRef float `C4Att`)
- e) int `Set_ChannelStartupAtt`(int `Channel`, int `StartupAtt`)
- f) int `Get_ChannelStartupAtt`(int `Channel`)

#### 4.4 (d) - DLL Functions for Ethernet Configuration

```
a) int GetEthernet_CurrentConfig(ByRef int IP1, int IP2,
                                ByRef int IP3, ByRef int IP4, ByRef int Mask1,
                                ByRef int Mask2, ByRef int Mask3, ByRef int Mask4,
                                ByRef int Gateway1, ByRef int Gateway2,
                                ByRef int Gateway3, ByRef int Gateway4)
b) int GetEthernet_IPAddress (ByRef int b1, ByRef int b2,
                              ByRef int b3, int b4)
c) int GetEthernet_MACAddress (ByRef int MAC1 , ByRef int MAC2,
                               ByRef int MAC3, ByRef int MAC4,
                               ByRef int MAC5, ByRef int MAC6)
d) int GetEthernet_NetworkGateway (ByRef int b1, ByRef int b2,
                                    ByRef int b3, ByRef int b4)
e) int GetEthernet_SubNetMask (ByRef int b1, ByRef int b2,
                               ByRef int b3, ByRef int b4)
f) int GetEthernet_TCPIPPort (ByRef int port)
g) int GetEthernet_TelnetPort (ByRef int port)
h) int GetEthernet_TelnetPromptEn ()
i) int GetEthernet_TelnetPromptText (ByRef string PromptText)
j) int GetEthernet_UseDHCP ()
k) int GetEthernet_UsePWD ()
l) int GetEthernet_PWD (ByRef string Pwd)
m) int SaveEthernet_IPAddress (int b1, int b2, int b3, int b4)
n) int SaveEthernet_NetworkGateway (int b1, int b2, int b3, int b4)
o) int SaveEthernet_SubnetMask (int b1, int b2, int b3, int b4)
p) int SaveEthernet_TCPIPPort (int port)
q) int SaveEthernet_TelnetPort (int port)
r) int SaveEthernet_TelnetPromptEn (int en)
s) int SaveEthernet_TelnetPromptText (string PromptText)
t) int SaveEthernet_UseDHCP (int UseDHCP)
u) int SaveEthernet_UsePWD (int UsePwd)
v) int SaveEthernet_PWD (string Pwd)
w) int SaveEthernet_EnableEthernet (int EnableEth)
x) int GetEthernet_EnableEthernet ()
```

#### 4.4 (e) - DLL Functions for Attenuation Hopping

```
a) int Hop_SetNoOfPoints(int HopNoOfPoints)
b) int Hop_GetNoOfPoints()
c) int Hop_GetMaxNoOfPoints()
d) int Hop_SetDirection(int HopDirection)
e) int Hop_GetDirection()
f) int Hop_GetMaxDwell()
g) int Hop_GetMinDwell()
h) int Hop_SetPoint(int PointNo, float HopPower, int HopDwT,
                    int HopDwTUnits)
i) int Hop_GetPoint(int PointNo, ByRef float HopPower,
                    ByRef int HopDwT, ByRef int HopDwTUnits)
j) int Hop_SetActiveChannels(int CH1_YesNO, int CH2_YesNO,
                             int CH3_YesNO, int CH4_YesNO)
k) int Hop_GetActiveChannels(ByRef int CH1_YesNO,
                             ByRef int CH2_YesNO, ByRef int CH3_YesNO, ByRef int CH4_YesNO)
l) int Hop_SetPoint4Channels(int PointNo, float HopAtt1,
                             float HopAtt2, float HopAtt3, float HopAtt4,
                             int HopDwT, int HopDwTUnits)
m) int Hop_GetPoint4Channels(int PointNo, ByRef float HopAtt1,
                             ByRef float HopAtt2, ByRef float HopAtt3,
                             ByRef float HopAtt4, ByRef string HopDwT)
n) int Hop_SetMode(int On_Off)
```

#### 4.4 (f) - DLL Functions for Attenuation Sweeping / Fading

```
a) int Sweep_SetDirection(int SweepDirection)
b) int Sweep_GetDirection()
c) int Sweep_SetDwell(int Dwell, int Dwell_Units)
d) int Sweep_GetDwell()
e) int Sweep_GetMaxDwell()
f) int Sweep_GetMinDwell()
g) int Sweep_SetStartAtt(single Att)
h) single Sweep_GetStartAtt()
i) int Sweep_SetStopAtt(single Att)
j) single Sweep_GetStopAtt()
k) int Sweep_SetStepSize(single Att)
l) single Sweep_GetStepSize()
m) int Sweep_SetActiveChannels(int CH1_YesNO, int CH2_YesNO,
                               int CH3_YesNO, int CH4_YesNO)
n) int Sweep_GetActiveChannels(ByRef int CH1_YesNO,
                               ByRef int CH2_YesNO, ByRef int CH3_YesNO, ByRef int CH4_YesNO)
o) int Sweep_SetChannelStartAtt(int Channel, float Att)
p) float Sweep_GetChannelStartAtt(int Channel)
q) int Sweep_SetChannelStopAtt(int Channel, float Att)
r) float Sweep_GetChannelStopAtt(int Channel)
s) int Sweep_SetChannelStepSize(int Channel, float Att)
t) float Sweep_GetChannelStepSize(int Channel)
u) int Sweep_SetMode(int On_Off)
```

## 4.5 - DLL Function Explanations - USB Control

### 4.5 (a) - Get List of Connected Serial Numbers

#### Declaration

```
int Get_Available_SN_List(ByRef String SN_List)
```

#### Description

Returns a list of serial numbers for all connected programmable attenuators.

#### Parameters

Data Type	Variable	Description
String	SN_List	Variable passed by reference, to be updated with a list of all connected serial numbers, separated by a single space, for example "11301210001 11301210002 11301210003".

#### Return Values

Data Type	Value	Description
int	0	Command failed
int	1	Command completed successfully

#### Examples

##### Visual Basic

```
If MyPTE1.Get_Available_SN_List(SN_List) > 0 Then
    array_SN() = Split(SN_List, " ")
    ' Split the list into an array of serial numbers
    For i As Integer = 0 To array_SN.Length - 1
        ' Loop through the array and use each serial number
    Next
End If
```

##### Visual C++

```
if (MyPTE1->Get_Available_SN_List(SN_List) > 0)
{
    // split the List into array of SN's
}
}
```

##### Visual C#

```
if (MyPTE1.Get_Available_SN_List(ref(SN_List)) > 0)
{
    // split the List into array of SN's
}
}
```

##### Matlab

```
[status, SN_List]= MyPTE1.Get_Available_SN_List(SN_List)
if status > 0
    % split the List into array of SN's
end
```

#### See Also

[Get Device Serial Number](#)

## 4.5 (b) - Get List of Available Addresses

### Declaration

```
int Get_Available_Address_List(ByRef String Add_List)
```

### Description

Returns a list of USB addresses for all connected programmable attenuators.

### Parameters

Data Type	Variable	Description
String	Add_List	Variable passed by reference, to be updated with a list of all connected addresses separated by a single space character, for example, "5 101 254 255"

### Return Values

Data Type	Value	Description
int	0	Command failed
int	Non zero	The number of devices connected

### Examples

#### Visual Basic

```
If MyPTE1.Get_Available_Add_List(Add_List) > 0 Then
    ' Get list of available addresses
    array_Ad() = Split(Add_List, " ")
    ' Split the list into an array of addresses
    For i As Integer = 0 To array_Ad.Length - 1
        ' Loop through the array and use each address
    Next
End If
```

#### Visual C++

```
if (MyPTE1->Get_Available_Address_List(Add_List) > 0);
{
    // split the List into array of Addresses
}
```

#### Visual C#

```
if (MyPTE1.Get_Available_Address_List(ref(Add_List)) > 0)
{
    // split the List into array of Addresses
}
```

#### Matlab

```
[status, Add_List]= MyPTE1.Get_Available_Address_List(Add_List)
if status > 0
    % split the List into array of Addresses
end
```

### See Also

[Connect to Attenuator by Address](#)

[Set USB Address](#)

[Get USB Address](#)

## 4.5 (c) - Connect to Attenuator

### Declaration

```
int Connect(Optional String SN)
```

### Description

This function is called to initialize the connection to a programmable attenuator. If multiple attenuators are connected to the same computer, then the serial number should be included, otherwise this can be omitted. The connection process can take a few milliseconds so it is recommended that the connection be made once at the beginning of the routine and left open until the attenuator is no longer needed. The attenuator should be disconnected on completion of the program using the [Disconnect](#) function.

### Parameters

Data Type	Variable	Description
String	SN	Optional. The serial number of the programmable attenuator. Can be omitted if only one attenuator is connected.

### Return Values

Data Type	Value	Description
int	0	No connection was possible
	1	Connection successfully established
	2	Connection already established (Connect has been called more than once). The attenuator will continue to operate normally.

### Examples

#### Visual Basic

```
status = MyPTE1.Connect(SN)
```

#### Visual C++

```
status = MyPTE1->Connect(SN);
```

#### Visual C#

```
status = MyPTE1.Connect(SN);
```

#### Matlab

```
status = MyPTE1.Connect(SN)
```

### See Also

[Connect to Attenuator by Address](#)

[Disconnect from Attenuator](#)

## 4.5 (d) - Connect to Attenuator by Address

### Declaration

```
int ConnectByAddress (Optional int Address)
```

### Description

This function is called to initialize the USB connection to a programmable attenuator by referring to a user defined address. The address is an integer number from 1 to 255 which can be assigned using the [Set\\_Address](#) function (the factory default is 255). The connection process can take a few milliseconds so it is recommended that the connection be made once at the beginning of the routine and left open until the attenuator is no longer needed. The attenuator should be disconnected on completion of the program using the [Disconnect](#) function.

### Parameters

Data Type	Variable	Description
int	Address	Optional. A short containing the address of the attenuator. Can be omitted if only one device is connected but must be included otherwise.

### Return Values

Data Type	Value	Description
int	0	No connection was possible
	1	Connection successfully established
	2	Device already connected

### Examples

#### Visual Basic

```
status = MyPTE1.ConnectByAddress (5)
```

#### Visual C++

```
status = MyPTE1->ConnectByAddress (5) ;
```

#### Visual C#

```
status = MyPTE1.ConnectByAddress (5) ;
```

#### Matlab

```
status = MyPTE1.connectByAddress (5)
```

### See Also

[Connect to Attenuator](#)

[Disconnect from Attenuator](#)

## 4.5 (e) - Disconnect from Attenuator

### Declaration

```
Void Disconnect ()
```

### Description

This function is called to close the connection to the programmable attenuator. It is strongly recommended that this function is used prior to ending the program. Failure to do so may result in a connection problem with the device. Should this occur, shut down the program and unplug the attenuator from the computer, then reconnect the attenuator before attempting to start again.

### Parameters

Data Type	Variable	Description
None		

### Return Values

Data Type	Value	Description
None		

### Examples

**Visual Basic**

```
MyPTE1.Disconnect ()
```

**Visual C++**

```
MyPTE1->Disconnect ();
```

**Visual C#**

```
MyPTE1.Disconnect ();
```

**Matlab**

```
MyPTE1.Disconnect
```

### See Also

[Connect to Attenuator](#)

[Connect to Attenuator by Address](#)

## 4.5 (f) - Read Model Name

### Declaration

```
int Read_ModelName (ByRef String ModelName)
```

### Description

This function is called to determine the Mini-Circuits part number of the connected programmable attenuator. The user passes a string variable which is updated with the part number.

### Parameters

Data Type	Variable	Description
String	ModelName	Required. A string variable that will be updated with the Mini-Circuits part number for the programmable attenuator.

### Return Values

Data Type	Value	Description
int	0	Command failed
	1	Command completed successfully

### Examples

#### Visual Basic

```
If MyPTE1.Read_ModelName (ModelName) > 0 Then
    MsgBox ("The connected attenuator is " & ModelName)
    ' Display a message stating the model name
End If
```

#### Visual C++

```
if (MyPTE1->Read_ModelName (ModelName) > 0 )
{
    MessageBox::Show ("The connected attenuator is " + ModelName);
    // Display a message stating the model name
}
```

#### Visual C#

```
if (MyPTE1.Read_ModelName (ref (ModelName)) > 0 )
{
    MessageBox.Show ("The connected attenuator is " + ModelName);
    // Display a message stating the model name
}
```

#### Matlab

```
[status, ModelName]= MyPTE1.Read_ModelName (ModelName)
if status > 0
    h = msgbox ('The connected attenuator is ', ModelName)
    % Display a message stating the model name
end
```

### See Also

[Read Serial Number](#)

## 4.5 (g) - Read Serial Number

### Declaration

```
int Read_SN(ByRef String SN)
```

### Description

This function is called to determine the serial number of the connected programmable attenuator. The user passes a string variable which is updated with the serial number.

### Parameters

Data Type	Variable	Description
String	ModelName	Required. String variable that will be updated with the serial number for the programmable attenuator.

### Return Values

Data Type	Value	Description
int	0	Command failed
	1	Command completed successfully

### Examples

#### Visual Basic

```
If MyPTE1.Read_SN(SN) > 0 Then
    MsgBox ("The connected generator is " & SN)
    'Display a message stating the serial number
End If
```

#### Visual C++

```
if (MyPTE1->Read_SN(SN) > 0 )
{
    MessageBox::Show("The connected generator is " + SN);
    // Display a message stating the serial number
}
```

#### Visual C#

```
if (MyPTE1.Read_SN(ref(SN)) > 0 )
{
    MessageBox.Show("The connected generator is " + SN);
    // Display a message stating the serial number
}
```

#### Matlab

```
[status, SN]= MyPTE1.Read_SN(SN)
if status > 0
    h = msgbox('The connected generator is ', SN)
    % Display a message stating the serial number
end
```

### See Also

[Read Model Name](#)

[Get List of Connected Serial Numbers](#)

## 4.5 (h) - Set USB Address

### Declaration

```
int Set_Address (int Address)
```

### Description

This function sets the internal address of the attenuator connected via USB (the factory default address is 255). This allows the user to connect by a short address rather than serial number in future.

### Parameters

Data Type	Variable	Description
int	Address	Required. An integer value from 1 to 255

### Return Values

Data Type	Value	Description
int	0	Command failed
	Non zero	Command completed successfully

### Examples

#### Visual Basic

```
status = MyPTE1.Set_Address(1)
```

#### Visual C++

```
status = MyPTE1->Set_Address(1);
```

#### Visual C#

```
status = MyPTE1.Set_Address(1);
```

#### Matlab

```
status = MyPTE1.Set_Address(1)
```

### See Also

[Get USB Address](#)

[Get List of Available Addresses](#)

[Connect to Attenuator by Address](#)

## 4.5 (i) - Get USB Address

### Declaration

```
int Get_Address ()
```

### Description

This function returns the USB address of the connected attenuator.

### Parameters

Data Type	Variable	Description
None		

### Return Values

Data Type	Value	Description
int	0	Command failed
int	1-255	Address of the attenuator

### Examples

**Visual Basic**

```
addr = MyPTE1.Get_Address ()
```

**Visual C++**

```
addr = MyPTE1->Get_Address ();
```

**Visual C#**

```
addr = MyPTE1.Get_Address ();
```

**Matlab**

```
addr = MyPTE1.Get_Address
```

### See Also

[Set USB Address](#)

[Get List of Available Addresses](#)

[Connect to Attenuator by Address](#)

## 4.5 (j) - Set Start-Up Attenuation Mode

### Declaration

```
int Set_StartUpAttIndicator(int Indicator)
```

### Description

Sets the start-up mode to be used by the attenuator, this specifies how the initial attenuation value will be chosen when DC power is applied.

Note: See [Store Last Attenuation Value](#) if operating in "Last Attenuation" mode.

### Requirements

Firmware version A6 or later

### Parameters

Data Type	Variable	Description
int	Indicator	A numeric code indicating the start-up attenuation mode: 76 = Last Attenuation - The attenuation will be set to the same level as when the device was last powered off 70 = Fixed Attenuation - The attenuation will be set to a pre-defined value 78 = Default - The attenuator will assume the factory default state (maximum attenuation)

### Return Values

Data Type	Value	Description
int	0	Command failed
	1	Command completed successfully

### Examples

#### Visual Basic

```
Status = MyPTE1.Set_StartUpAttIndicator(70)
```

#### Visual C++

```
Status = MyPTE1->Set_StartUpAttIndicator(70);
```

#### Visual C#

```
Status = MyPTE1.Set_StartUpAttIndicator(70);
```

#### Matlab

```
Status = MyPTE1.Set_StartUpAttIndicator(70)
```

### See Also

[Get Start-Up Attenuation Mode](#)  
[Set Start-Up Attenuation Value](#)  
[Get Start-Up Attenuation Value](#)  
[Store Last Attenuation Value](#)

## 4.5 (k) - Get Start-Up Attenuation Mode

### Declaration

```
int Get_StartUpAttIndicator ()
```

### Description

Returns the start-up mode to be used by the attenuator, this specifies how the initial attenuation value will be chosen when DC power is applied.

### Requirements

Model Name	Serial Number	Firmware
RC4DAT or RC8DAT series	All	All
RCDAT, RUDAT or ZVVA series	All	A6 or later

### Parameters

Data Type	Variable	Description
none		

### Return Values

Data Type	Value	Description
int	76	Last Attenuation - The attenuation will be set to the same level as when the device was last powered off
	70	Fixed Attenuation - The attenuation will be set to a pre-defined value
	78	Default - The attenuator will assume the factory default state (maximum attenuation)

### Examples

```

Visual Basic
Mode = MyPTE1.Get_StartUpAttIndicator ()
Visual C++
Mode = MyPTE1->Get_StartUpAttIndicator ();
Visual C#
Mode = MyPTE1.Get_StartUpAttIndicator ();
Matlab
Mode = MyPTE1.Get_StartUpAttIndicator ()
    
```

### See Also

[Set Start-Up Attenuation Mode](#)  
[Set Start-Up Attenuation Value](#)  
[Get Start-Up Attenuation Value](#)  
[Store Last Attenuation Value](#)

## 4.5 (I) - Store Last Attenuation Value

### Declaration

```
int InitiateStoreLastAtt ()
```

### Description

Saves the current attenuation value to permanent memory so that it can be recalled when the attenuator is next powered back on. Only applies when the attenuator is configured to power-up in "Last Attenuation" mode.

### Requirements

Model Name	Serial Number	Firmware
RC4DAT or RC8DAT series	All	All
RCDAT, RUDAT or ZVVA series	All	C3 or later

### Return Values

Data Type	Value	Description
Short	0	Command failed
	1	Command completed successfully

### Example

```

Visual Basic
    status = MyPTE1.InitiateStoreLastAtt()
Visual C++
    status = MyPTE1->InitiateStoreLastAtt();
Visual C#
    status = MyPTE1.InitiateStoreLastAtt();
Matlab
    status = MyPTE1.InitiateStoreLastAtt()
    
```

### See Also

[Set Start-Up Attenuation Mode](#)

[Get Start-Up Attenuation Mode](#)

## 4.5 (m) - Send SCPI Command

### Declaration

```
Short Send_SCPI(String SndSTR, ByRef String RetSTR)
```

### Description

This function sends a SCPI command to the programmable attenuator and collects the returned acknowledgement. SCPI (Standard Commands for Programmable Instruments) is a common method for communicating with and controlling instrumentation products.

### Parameters

Data Type	Variable	Description
String	SndSTR	The SCPI command / query to send
String	RetSTR	String variable which will be updated with the attenuator's response to the command / query

### Return Values

Data Type	Value	Description
Short	0	Command failed
	1	Command completed successfully

### Examples

#### Visual Basic

```
Status = MyPTE1.Send_SCPI("MN?", RetStr)
' Send SCPI command to return the model name
```

#### Visual C++

```
Status = MyPTE1->Send_SCPI("MN?", RetStr);
// Send SCPI command to return the model name
```

#### Visual C#

```
Status = MyPTE1.Send_SCPI("MN?", RetStr);
// Send SCPI command to return the model name
```

#### Matlab

```
[Status, RetStr] = MyPTE1.Send_SCPI("MN?", RetStr)
% Send SCPI command to return the model name
```

### See Also

[Summary of SCPI Commands / Queries](#)

## 4.5 (n) - Get USB Connection Status

### Declaration

```
int GetUSBConnectionStatus ()
```

### Description

This function checks whether the USB connection to the programmable attenuator is still active.

### Parameters

Data Type	Variable	Description
None		

### Return Values

Data Type	Value	Description
int	0	No connection
int	1	USB connection to programmable attenuator is active

### Examples

#### Visual Basic

```
If MyPTE1.GetUSBConnectionStatus = 1 Then
    ' programmable attenuator is connected
End If
```

#### Visual C++

```
if (MyPTE1->GetUSBConnectionStatus() == 1)
{
    // programmable attenuator is connected
}
```

#### Visual C#

```
if (MyPTE1.GetUSBConnectionStatus() == 1)
{
    // programmable attenuator is connected
}
```

#### Matlab

```
usbstatus = MyPTE1.GetUSBConnectionStatus
if usbstatus == 1
    % programmable attenuator is connected
end
```

### See Also

[Get Firmware Version](#)

## 4.5 (o) - Get Status (Antiquated)

### Declaration

```
int GetStatus ()
```

### Description

This function is antiquated; please use [Get USB Connection Status](#) instead. GetStatus checks whether the USB connection to the attenuator is active.

### Parameters

Data Type	Variable	Description
None		

### Return Values

Data Type	Value	Description
int	0	No connection
int	1	USB connection to attenuator is active

### Example

```
Visual Basic  
Status = MyPTE1.GetStatus ()  
Visual C++  
Status = MyPTE1->GetStatus ();  
Visual C#  
Status = MyPTE1.GetStatus ();  
Matlab  
Status = MyPTE1.GetStatus ()
```

### See Also

[Get USB Connection Status](#)

## 4.5 (p) - Get Firmware

### Declaration

```
int GetExtFirmware (ByRef int A0, ByRef int A1, ByRef int A2,
                   ByRef string Firmware)
```

### Description

This function returns the internal firmware version of the attenuator along with three reserved variables for factory use.

### Parameters

Data Type	Variable	Description
int	A0	Required. User defined variable for factory use only.
int	A1	Required. User defined variable for factory use only.
int	A2	Required. User defined variable for factory use only.
String	Firmware	Required. User defined variable which will be updated with the current firmware version, for example "B3".

### Return Values

Data Type	Value	Description
int	0	Command failed
int	1	Command completed successfully

### Examples

#### Visual Basic

```
If MyPTE1.GetExtFirmware(A0, A1, A2, Firmware) > 0 Then
    MsgBox ("Firmware version is " & Firmware)
End If
```

#### Visual C++

```
if (MyPTE1->GetExtFirmware(A0, A1, A2, Firmware) > 0 )
{
    MessageBox::Show("Firmware version is " + Firmware);
}
```

#### Visual C#

```
if (MyPTE1.GetExtFirmware(ref(A0, A1, A2, Firmware)) > 0 )
{
    MessageBox.Show("Firmware version is " + Firmware);
}
```

#### Matlab

```
[status, A0, A1, A2, Firmware]=MyPTE1.GetExtFirmware(A0, A1, A2, Firmware)
if status > 0
    h = msgbox('Firmware version is ', Firmware)
end
```

## 4.6 - DLL Function Explanations - ZVVA / RUDAT / RCDAT (Single Channel) Models

### 4.6 (a) - Set Attenuation

#### Declaration - ActiveX

```
int SetAttenuation (ByRef Float TotalAtt)
```

#### Declaration - .NET

```
int SetAttenuation (Float TotalAtt)
```

#### Description

This function sets the RF attenuation level. The allowed attenuation range and precision is defined in the individual model datasheets.

#### Applies To

ZVVA, RUDAT and RCDAT models

#### Parameters

Data Type	Variable	Description
Float	TotalAtt	Required. Numeric value indicating the attenuation to set.

#### Return Values

Data Type	Value	Description
int	0	Command failed or invalid attenuation set
	1	Command completed successfully
	2	Requested attenuation was higher than the allowed range, the attenuation was set to the device's maximum allowed value

#### Examples

##### Visual Basic

```
Status = MyPTE1.SetAttenuation (TotalAtt)
```

##### Visual C++

```
Status = MyPTE1->SetAttenuation (TotalAtt) ;
```

##### Visual C#

```
Status = MyPTE1.SetAttenuation (TotalAtt) ;
```

##### Matlab

```
Status = MyPTE1.SetAttenuation (TotalAtt)
```

#### See Also

[Read Attenuation](#)

## 4.6 (b) - Read Attenuation

### Declaration

```
int Read_Att (ByRef Float CAtt1)
```

### Description

This function indicates the current attenuation setting.

### Applies To

ZVVA, RUDAT and RCDAT models

### Parameters

Data Type	Variable	Description
Float	CAtt1	Required. User defined variable which will be updated with the current attenuation setting.

### Return Values

Data Type	Value	Description
int	0	Command failed
	1	Command completed successfully

### Examples

#### Visual Basic

```
Status = MyPTE1.Read_Att(Att)
```

#### Visual C++

```
Status = MyPTE1->Read_Att(Att);
```

#### Visual C#

```
Status = MyPTE1.Read_Att(Att);
```

#### Matlab

```
[Status, Att] = MyPTE1.Read_Att(Att)
```

### See Also

[Set Attenuation](#)

## 4.6 (c) - Set Start-Up Attenuation Value

### Declaration

```
int Set_StartUpAtt(single AttVal)
```

### Description

Sets the attenuation value to be loaded when the attenuator is first powered up in "Fixed Attenuation" start-up mode.

### Applies To

Model Name	Serial Number	Firmware
RCDAT, RUDAT or ZVVA series	All	A6 or later

### Parameters

Data Type	Variable	Description
single	AttVal	The initial attenuation level to be loaded on start-up

### Return Values

Data Type	Value	Description
int	0	Command failed
	1	Command completed successfully

### Examples

#### Visual Basic

```
Status = MyPTE1.Set_StartUpAtt(25.75)
```

#### Visual C++

```
Status = MyPTE1->Set_StartUpAtt(25.75);
```

#### Visual C#

```
Status = MyPTE1.Set_StartUpAtt(25.75);
```

#### Matlab

```
Status = MyPTE1.Set_StartUpAtt(25.75)
```

### See Also

[Set Start-Up Attenuation Mode](#)

[Get Start-Up Attenuation Mode](#)

[Get Start-Up Attenuation Value](#)

## 4.6 (d) - Get Start-Up Attenuation Value

### Declaration

```
single Get_StartUpAtt ()
```

### Description

Gets the attenuation value to be loaded when the attenuator is first powered up in "Fixed Attenuation" start-up mode.

### Applies To

Model Name	Serial Number	Firmware
RCDAT, RUDAT or ZVVA series	All	A6 or later

### Parameters

Data Type	Variable	Description
none		

### Return Values

Data Type	Value	Description
single	AttVal	The initial attenuation level to be loaded on start-up

### Examples

#### Visual Basic

```
Att = MyPTE1.Get_StartUpAtt ()
```

#### Visual C++

```
Att = MyPTE1->Get_StartUpAtt ();
```

#### Visual C#

```
Att = MyPTE1.Get_StartUpAtt ();
```

#### Matlab

```
Att = MyPTE1.Get_StartUpAtt ()
```

### See Also

[Set Start-Up Attenuation Mode](#)  
[Get Start-Up Attenuation Mode](#)  
[Set Start-Up Attenuation Value](#)  
[Store Last Attenuation Value](#)

## 4.7 - DLL - RC4DAT (Multi-Channel) Attenuation Functions

These functions apply to RC4DAT models only

### 4.7 (a) - Set Attenuation - Single Channel

#### Declaration

```
int SetChannelAtt(int Channel, float Att)
```

#### Description

Sets the attenuation for a single channel within the multi-channel attenuator.

#### Applies To

RC4DAT & RC8DAT Series

#### Parameters

Data Type	Variable	Description
int	Channel	The channel number
float	Att	The attenuation value (dB) to set

#### Return Values

Data Type	Value	Description
int	0	Command failed
	1	Command completed successfully

#### Examples

##### Visual Basic

```
Status = MyPTE1.SetChannelAtt(2, 15.75)
```

##### Visual C++

```
Status = MyPTE1->SetChannelAtt(2, 15.75);
```

##### Visual C#

```
Status = MyPTE1.SetChannelAtt(2, 15.75);
```

##### Matlab

```
Status = MyPTE1.SetChannelAtt(2, 15.75)
```

#### See Also

[Set Attenuation - All Channels](#)

[Get Attenuation Value - Single Channel](#)

[Get Attenuation Value - All Channels](#)

## 4.7 (b) - Set Attenuation - All Channels Same Value

### Declaration

```
int SetChannelsAtt(float Att, int CH1, int CH2, int CH3, int CH4)
```

### Description

Sets up to 4 channels of the multi-channel attenuator to the same attenuation value.

### Applies To

RC4DAT Series

### Parameters

Data Type	Variable	Description
float	Att	The attenuation value (dB) to set
int	CH1	1 to set CH1, 0 to leave channel 1 unchanged
int	CH2	1 to set CH2, 0 to leave channel 3 unchanged
int	CH3	1 to set CH3, 0 to leave channel 3 unchanged
int	CH4	1 to set CH4, 0 to leave channel 4 unchanged

### Return Values

Data Type	Value	Description
int	0	Command failed
	1	Command completed successfully

### Examples

#### Visual Basic

```
Status = MyPTE1.SetChannelsAtt(15.75, 1, 1, 0, 1)
' Set channels 1, 2 and 4 to 15.75 dB
```

#### Visual C++

```
Status = MyPTE1->SetChannelAtt(15.75, 1, 1, 0, 1);
// Set channels 1, 2 and 4 to 15.75 dB
```

#### Visual C#

```
Status = MyPTE1.SetChannelAtt(15.75, 1, 1, 0, 1);
// Set channels 1, 2 and 4 to 15.75 dB
```

#### Matlab

```
Status = MyPTE1.SetChannelAtt(15.75, 1, 1, 0, 1)
% Set channels 1, 2 and 4 to 15.75 dB
```

### See Also

[Set Attenuation - Single Channel](#)

[Get Attenuation Value - Single Channel](#)

[Get Attenuation Value - All Channels](#)

## 4.7 (c) - Get Attenuation Value - Single Channel

### Declaration

```
float ReadChannelAtt(int Channel)
```

### Description

Returns the value for a single channel within the multi-channel attenuator.

### Applies To

RC4DAT & RC8DAT Series

### Parameters

Data Type	Variable	Description
int	Channel	The channel number

### Return Values

Data Type	Value	Description
float	AttVal	The attenuation level (dB) for the specified channel

### Examples

#### Visual Basic

```
Att = MyPTE1.ReadChannelAtt(3)
```

#### Visual C++

```
Att = MyPTE1->ReadChannelAtt(3);
```

#### Visual C#

```
Att = MyPTE1.ReadChannelAtt(3);
```

#### Matlab

```
Att = MyPTE1.ReadChannelAtt(3)
```

### See Also

[Set Attenuation - Single Channel](#)

[Set Attenuation - All Channels](#)

[Get Attenuation Value - All Channels](#)

## 4.7 (d) - Get Attenuation Value - All Channels

### Declaration

```
int Read4ChannelsAtt (ByRef float C1Att, ByRef float C2Att,
                    ByRef float C3Att, ByRef float C4Att)
```

### Description

Returns the attenuation values for all channels within the multi-channel attenuator.

### Applies To

RC4DAT Series

### Parameters

Data Type	Variable	Description
float	C1Att	Reference to a variable which will be updated with the attenuation value for channel 1
float	C2Att	Reference to a variable which will be updated with the attenuation value for channel 2
float	C3Att	Reference to a variable which will be updated with the attenuation value for channel 3
float	C4Att	Reference to a variable which will be updated with the attenuation value for channel 4

### Return Values

Data Type	Value	Description
int	0	Command failed
	1	Command completed successfully

### Examples

#### Visual Basic

```
status = MyPTE1.Read4ChannelsAtt(Att1, Att2, Att3, Att4)
```

#### Visual C++

```
status = MyPTE1->Read4ChannelsAtt(Att1, Att2, Att3, Att4);
```

#### Visual C#

```
status = MyPTE1.Read4ChannelsAtt(ref(Att1), ref(Att2), ref(Att3), ref(Att4));
```

#### Matlab

```
[status,Att1,Att2,Att3,Att4]=MyPTE1.Read4ChannelsAtt(Att1, Att2, Att3, Att4)
```

### See Also

[Set Attenuation - Single Channel](#)

[Set Attenuation - All Channels](#)

[Get Attenuation Value - Single Channel](#)

## 4.7 (e) - Set Channel Start-Up Attenuation Value

### Declaration

```
int Set_ChannelStartUpAtt(int Channel, int StartUpAtt)
```

### Description

Sets the start up attenuation value for a single channel within the multi-channel attenuator (the attenuation value to be loaded when DC power is applied).

### Applies To

RC4DAT & RC8DAT Series

### Parameters

Data Type	Variable	Description
int	Channel	The channel number
int	StartUpAtt	The initial attenuation value (dB) to be loaded on start-up

### Return Values

Data Type	Value	Description
int	0	Command failed
	1	Command completed successfully

### Examples

#### Visual Basic

```
Status = MyPTE1.Set_ChannelStartUpAtt(3, 25.75)
```

#### Visual C++

```
Status = MyPTE1->Set_ChannelStartUpAtt(3, 25.75);
```

#### Visual C#

```
Status = MyPTE1.Set_ChannelStartUpAtt(3, 25.75);
```

#### Matlab

```
Status = MyPTE1.Set_ChannelStartUpAtt(3, 25.75)
```

### See Also

[Get Channel Start-Up Attenuation Value](#)

## 4.7 (f) - Get Channel Start-Up Attenuation Value

### Declaration

```
int Get_ChannelStartUpAtt(int Channel)
```

### Description

Returns the start up attenuation value for a single channel within the multi-channel attenuator (the attenuation value to be loaded when DC power is applied).

### Applies To

RC4DAT & RC8DAT Series

### Parameters

Data Type	Variable	Description
int	Channel	The channel number

### Return Values

Data Type	Value	Description
int	AttVal	The initial attenuation value (dB) to be loaded on start-up

### Examples

#### Visual Basic

```
Att = MyPTE1.Get_ChannelStartUpAtt(3)
```

#### Visual C++

```
Att = MyPTE1->Get_ChannelStartUpAtt(3);
```

#### Visual C#

```
Att = MyPTE1.Get_ChannelStartUpAtt(3);
```

#### Matlab

```
Att = MyPTE1.Get_ChannelStartUpAtt(3)
```

### See Also

[Set Channel Start-Up Attenuation Value](#)

## 4.8 - DLL Function Explanations - Ethernet Configuration

### 4.8 (a) - Get Ethernet Configuration

#### Declaration

```
int GetEthernet_CurrentConfig(
    ByRef int IP1, ByRef int IP2, ByRef int IP3, ByRef int IP4,
    ByRef int Mask1, ByRef int Mask2, ByRef int Mask3, ByRef int Mask4,
    ByRef int Gateway1, ByRef int Gateway2,
    ByRef int Gateway3, ByRef int Gateway4)
```

#### Requirements

RC Series programmable attenuator with RJ45 network interface.

#### Description

This function returns the current IP configuration of the connected attenuator in a series of user defined variables. The settings checked are IP address, subnet mask and network gateway.

#### Parameters

Data Type	Variable	Description
int	IP1	Required. Integer variable which will be updated with the first (highest order) octet of the IP address.
int	IP2	Required. Integer variable which will be updated with the second octet of the IP address.
int	IP3	Required. Integer variable which will be updated with the third octet of the IP address.
int	IP4	Required. Integer variable which will be updated with the last (lowest order) octet of the IP address.
int	Mask1	Required. Integer variable which will be updated with the first (highest order) octet of the subnet mask.
int	Mask2	Required. Integer variable which will be updated with the second octet of the subnet mask.
int	Mask3	Required. Integer variable which will be updated with the third octet of the subnet mask.
int	Mask4	Required. Integer variable which will be updated with the last (lowest order) octet of the subnet mask.
int	Gateway1	Required. Integer variable which will be updated with the first (highest order) octet of the network gateway.
int	Gateway2	Required. Integer variable which will be updated with the second octet of the network gateway.
int	Gateway3	Required. Integer variable which will be updated with the third octet of the network gateway.
int	Gateway4	Required. Integer variable which will be updated with the last (lowest order) octet of the network gateway.

## Return Values

Data Type	Value	Description
int	0	Command failed
int	1	Command completed successfully

## Example

### Visual Basic

```

If MyPTE1.GetEthernet_CurrentConfig(IP1, IP2, IP3, IP4, M1, M2, M3, M4,
    _ GW1, GW2, GW3, GW4) > 0 Then

    MsgBox ("IP address: " & IP1 & "." & IP2 & "." & IP3 & "." & IP4)
    MsgBox ("Subnet Mask: " & M1 & "." & M2 & "." & M3 & "." & M4)
    MsgBox ("Gateway: " & GW1 & "." & GW2 & "." & GW3 & "." & GW4)

End If

```

### Visual C++

```

if (MyPTE1->GetEthernet_CurrentConfig(IP1, IP2, IP3, IP4, M1, M2, M3, M4,
    _ GW1, GW2, GW3, GW4) > 0)
{
    MessageBox::Show("IP address: " + IP1 + "." + IP2 + "." + IP3 + "."
        + IP4);
    MessageBox::Show("Subnet Mask: " + M1 + "." + M2 + "." + M3+ "." +
        M4);
    MessageBox::Show("Gateway: " + GW1 + "." + GW2 + "." + GW3 + "." +
        GW4);
}

```

### Visual C#

```

if (MyPTE1.GetEthernet_CurrentConfig(IP1, IP2, IP3, IP4, M1, M2, M3, M4,
    _ GW1, GW2, GW3, GW4) > 0)
{
    MessageBox.Show("IP address: " + IP1 + "." + IP2 + "." + IP3 + "."
        + IP4);
    MessageBox.Show("Subnet Mask: " + M1 + "." + M2 + "." + M3+ "." +
        M4);
    MessageBox.Show("Gateway: " + GW1 + "." + GW2 + "." + GW3 + "." +
        GW4);
}

```

### Matlab

```

[status, IP1, IP2, IP3, IP4, M1, M2, M3, M4, GW1, GW2, GW3, GW4] =
MyPTE1.GetEthernet_CurrentConfig(IP1, IP2, IP3, IP4, M1, M2, M3, M4, GW1,
GW2, GW3, GW4)
if status > 0
    h = msgbox ("IP address: ", IP1, ".", IP2, ".", IP3, ".", IP4)
    h = msgbox ("Subnet Mask: ", M1, "." & M2, "." & M3, ".", M4)
    h = msgbox ("Gateway: ", GW1, ".", GW2, ".", GW3, ".", GW4)
end

```

## See Also

[Get MAC Address](#)  
[Get TCP/IP Port](#)

## 4.8 (b) - Get IP Address

### Declaration

```
int GetEthernet_IPAddress (ByRef int b1, ByRef int b2, ByRef int b3,
                           ByRef int b4)
```

### Description

This function returns the current IP address of the connected attenuator in a series of user defined variables (one per octet).

### Requirements

RC Series programmable attenuator with RJ45 network interface.

### Parameters

Data Type	Variable	Description
int	IP1	Required. Integer variable which will be updated with the first (highest order) octet of the IP address (for example "192" for the IP address "192.168.1.0").
int	IP2	Required. Integer variable which will be updated with the second octet of the IP address (for example "168" for the IP address "192.168.1.0").
int	IP3	Required. Integer variable which will be updated with the third octet of the IP address (for example "1" for the IP address "192.168.1.0").
int	IP4	Required. Integer variable which will be updated with the last (lowest order) octet of the IP address (for example "0" for the IP address "192.168.1.0").

### Return Values

Data Type	Value	Description
int	0	Command failed
int	1	Command completed successfully

### Example

**Visual Basic**

```
If MyPTE1.GetEthernet_CurrentConfig(IP1, IP2, IP3, IP4) > 0 Then
    MsgBox ("IP address: " & IP1 & "." & IP2 & "." & IP3 & "." & IP4)
End If
```

**Visual C++**

```
if (MyPTE1->GetEthernet_CurrentConfig(IP1, IP2, IP3, IP4) > 0)
{
    MessageBox::Show("IP address: " + IP1 + "." + IP2 + "." + IP3 + "."
        + IP4);
}
```

**Visual C#**

```
if (MyPTE1.GetEthernet_CurrentConfig(IP1, IP2, IP3, IP4) > 0)
{
    MessageBox.Show("IP address: " + IP1 + "." + IP2 + "." + IP3 + "."
        + IP4);
}
```

**Matlab**

```
[status, IP1, IP2, IP3, IP4] = MyPTE1.GetEthernet_CurrentConfig(IP1, IP2,
IP3, IP4)
if status > 0
    h = msgbox ("IP address: ", IP1, ".", IP2, ".", IP3, ".", IP4)
end
```

**See Also**[Get Ethernet Configuration](#)[Get TCP/IP Port](#)[Save IP Address](#)[Save TCP/IP Port](#)

## 4.8 (c) - Get MAC Address

### Declaration

```
int GetEthernet_MACAddress (ByRef int MAC1, ByRef int MAC2,
    ByRef int MAC3, ByRef int MAC4, ByRef int MAC5, ByRef int MAC6)
```

### Description

Returns the MAC (media access control) address, the physical address, of the connected attenuator as a series of decimal values (one for each of the 6 numeric groups).

### Requirements

RC Series programmable attenuator with RJ45 network interface.

### Parameters

Data Type	Variable	Description
int	MAC1	Passed by reference to be updated with the decimal value of the first section of the MAC address. For example: MAC address =11:47:165:103:137:171 MAC1=11
int	MAC2	Passed by reference to be updated with the decimal value of the second section of the MAC address. For example: MAC address =11:47:165:103:137:171 MAC2=47
int	MAC3	Passed by reference to be updated with the decimal value of the third section of the MAC address. For example: MAC address =11:47:165:103:137:171 MAC3=165
int	MAC4	Passed by reference to be updated with the decimal value of the fourth section of the MAC address. For example: MAC address =11:47:165:103:137:171 MAC4=103
int	MAC5	Passed by reference to be updated with the decimal value of the fifth section of the MAC address. For example: MAC address =11:47:165:103:137:171 MAC5=137
int	MAC6	Passed by reference to be updated with the decimal value of the sixth section of the MAC address. For example: MAC address =11:47:165:103:137:171 MAC6=171

## Return Values

Data Type	Value	Description
int	0	Command failed
int	1	Command completed successfully

## Example

### Visual Basic

```
If MyPTE1.GetEthernet_MACAddress(M1, M2, M3, M4, M5, M6) > 0 Then
    MsgBox ("MAC address: " & M1 & ":" & M2 & ":" & M3 & ":" & M4 & ":" & M5 & ":" & M6)
End If
```

### Visual C++

```
if (MyPTE1->GetEthernet_MACAddress(M1, M2, M3, M4, M5, M6) > 0)
{
    MessageBox::Show("MAC address: " + M1 + "." + M2 + "." + M3 + "." + M4 + "." + M5 + "." + M6);
}
}
```

### Visual C#

```
if (MyPTE1.GetEthernet_MACAddress(M1, M2, M3, M4, M5, M6) > 0)
{
    MessageBox.Show("MAC address: " + M1 + "." + M2 + "." + M3 + "." + M4 + "." + M5 + "." + M6);
}
}
```

### Matlab

```
[status, M1, M2, M3, M4, M5, M6] = MyPTE1.GetEthernet_MACAddress(M1, M2, M3, M4, M5, M6)
if status > 0
    h = msgbox ("MAC address: ", M1, ".", M2, ".", M3, ".", M4, ".", M5, ".", M6)
end
```

## See Also

[Get Ethernet Configuration](#)

## 4.8 (d) - Get Network Gateway

### Declaration

```
int GetEthernet_NetworkGateway (ByRef int b1, ByRef int b2,
                                ByRef int b3, ByRef int b4)
```

### Description

This function returns the IP address of the network gateway to which the attenuator is currently connected. A series of user defined variables are passed to the function to be updated with the IP address (one per octet).

### Requirements

RC Series programmable attenuator with RJ45 network interface.

### Parameters

Data Type	Variable	Description
int	IP1	Required. Integer variable which will be updated with the first (highest order) octet of the IP address (for example "192" for the IP address "192.168.1.0").
int	IP2	Required. Integer variable which will be updated with the second octet of the IP address (for example "168" for the IP address "192.168.1.0").
int	IP3	Required. Integer variable which will be updated with the third octet of the IP address (for example "1" for the IP address "192.168.1.0").
int	IP4	Required. Integer variable which will be updated with the last (lowest order) octet of the IP address (for example "0" for the IP address "192.168.1.0").

### Return Values

Data Type	Value	Description
int	0	Command failed
int	1	Command completed successfully

## Example

### Visual Basic

```
If MyPTE1.GetEthernet_NetworkGateway(IP1, IP2, IP3, IP4) > 0 Then
    MsgBox ("Gateway: " & IP1 & "." & IP2 & "." & IP3 & "." & IP4)
End If
```

### Visual C++

```
if (MyPTE1->GetEthernet_NetworkGateway(IP1, IP2, IP3, IP4) > 0)
{
    MessageBox::Show("Gateway: " + IP1 + "." + IP2 + "." + IP3 + "."
                    + IP4);
}
```

### Visual C#

```
if (MyPTE1.GetEthernet_NetworkGateway(IP1, IP2, IP3, IP4) > 0)
{
    MessageBox.Show("Gateway: " + IP1 + "." + IP2 + "." + IP3 + "."
                    + IP4);
}
```

### Matlab

```
[status, IP1, IP2, IP3, IP4] = MyPTE1.GetEthernet_NetworkGateway(IP1, IP2,
IP3, IP4)
if status > 0
    h = msgbox ("Gateway: ", IP1, ".", IP2, ".", IP3, ".", IP4)
end
```

## See Also

[Get Ethernet Configuration](#)

[Save Network Gateway](#)

## 4.8 (e) - Get Subnet Mask

### Declaration

```
int GetEthernet_SubNetMask (ByRef int b1, ByRef int b2, ByRef int b3,
                             ByRef int b4)
```

### Description

This function returns the subnet mask used by the network gateway to which the attenuator is currently connected. A series of user defined variables are passed to the function to be updated with the subnet mask (one per octet).

### Requirements

RC Series programmable attenuator with RJ45 network interface.

### Parameters

Data Type	Variable	Description
int	b1	Required. Integer variable which will be updated with the first (highest order) octet of the subnet mask (for example "255" for the subnet mask "255.255.255.0").
int	b2	Required. Integer variable which will be updated with the second octet of the subnet mask (for example "255" for the subnet mask "255.255.255.0").
int	b3	Required. Integer variable which will be updated with the third octet of the subnet mask (for example "255" for the subnet mask "255.255.255.0").
int	b4	Required. Integer variable which will be updated with the last (lowest order) octet of the subnet mask (for example "0" for the subnet mask "255.255.255.0").

### Return Values

Data Type	Value	Description
int	0	Command failed
int	1	Command completed successfully

## Example

### Visual Basic

```
If MyPTE1.GetEthernet_SubNetMask(b1, b2, b3, b4) > 0 Then
    MsgBox ("Subnet mask: " & b1 & "." & b2 & "." & b3 & "." & b4)
End If
```

### Visual C++

```
if (MyPTE1->GetEthernet_SubNetMask(b1, b2, b3, b4) > 0)
{
    MessageBox::Show("Subnet mask: " + b1 + "." + b2 + "." + b3 + "."
                    + b4);
}
```

### Visual C#

```
if (MyPTE1.GetEthernet_SubNetMask(b1, b2, b3, b4) > 0)
{
    MessageBox.Show("Subnet mask: " + b1 + "." + b2 + "." + b3 + "."
                    + b4);
}
```

### Matlab

```
[status, b1, b2, b3, b4] = MyPTE1.GetEthernet_SubNetMask(b1, b2, b3, b4)
if status > 0
    h = msgbox ("Subnet mask: ", b1, ".", b2, ".", b3, ".", b4)
end
```

## See Also

[Get Ethernet Configuration](#)

[Save Subnet Mask](#)

## 4.8 (f) - Get TCP/IP Port

### Declaration

```
int GetEthernet_TCPIPPort (ByRef int port)
```

### Description

Returns the TCP/IP port used by the attenuator for HTTP communication (default is port 80). Port 23 is reserved for Telnet communication and cannot be set as the HTTP port.

### Requirements

RC Series programmable attenuator with RJ45 network interface.

### Parameters

Data Type	Variable	Description
int	port	Required. Integer variable which will be updated with the TCP/IP port.

### Return Values

Data Type	Value	Description
int	0	Command failed
int	1	Command completed successfully

### Example

#### Visual Basic

```
If MyPTE1.GetEthernet_TCPIPPort(port) > 0 Then
    MsgBox ("Port: " & port)
End If
```

#### Visual C++

```
if (MyPTE1->GetEthernet_TCPIPPort(port) > 0)
{
    MessageBox::Show("Port: " + port);
}
```

#### Visual C#

```
if (MyPTE1.GetEthernet_TCPIPPort(port) > 0)
{
    MessageBox.Show("Port: " + port);
}
```

#### Matlab

```
[status, port] = MyPTE1.GetEthernet_TCPIPPort(port)
if status > 0
    h = msgbox ("Port: ", port)
end
```

### See Also

[Save TCP/IP Port](#)  
[Get Telnet Port](#)

## 4.8 (g) - Get Telnet Port

### Declaration

```
int GetEthernet_TelnetPort (ByRef int port)
```

### Description

Returns the port used by the attenuator for Telnet communication (default is port 23).

### Requirements

RC Series programmable attenuator with firmware C7 or above.

### Parameters

Data Type	Variable	Description
int	port	Required. Integer variable which will be updated with the Telnet port.

### Return Values

Data Type	Value	Description
int	0	Command failed
int	1	Command completed successfully

### Example

```
Visual Basic
If MyPTE1.GetEthernet_TelnetPort(port) > 0 Then
    MsgBox ("Port: " & port)
End If

Visual C++
if (MyPTE1->GetEthernet_TelnetPort(port) > 0)
{
    MessageBox::Show("Port: " + port);
}

Visual C#
if (MyPTE1.GetEthernet_TelnetPort(port) > 0)
{
    MessageBox.Show("Port: " + port);
}

Matlab
[status, port] = MyPTE1.GetEthernet_TelnetPort(port)
if status > 0
    h = msgbox ("Port: ", port)
end
```

### See Also

[Save Telnet Port](#)  
[Get TCP/IP Port](#)

## 4.8 (h) - Query Telnet Prompt Type

### Declaration

```
int GetEthernet_TelnetPromptEn ()
```

### Description

Indicates whether the custom Telnet prompt is enabled. When enabled, a custom text string will be returned as a prompt when the attenuator is ready to receive the next Telnet command. The custom prompt is disabled by default so only a new line character is returned.

### Requirements

RC Series programmable attenuator with firmware D5 or above.

### Return Values

Data Type	Value	Description
int	0	Custom Telnet prompt disabled (new line character will be returned)
int	1	Custom Telnet prompt enabled (see <a href="#">Set Custom Telnet Prompt Text</a> to set the text)

### Example

#### Visual Basic

```
If MyPTE1.GetEthernet_TelnetPromptEn() > 0 Then
    MsgBox ("Custom Telnet prompt enabled")
End If
```

#### Visual C++

```
if (MyPTE1->GetEthernet_TelnetPromptEn() > 0)
{
    MessageBox::Show("Custom Telnet prompt enabled");
}
```

#### Visual C#

```
if (MyPTE1.GetEthernet_TelnetPromptEn() > 0)
{
    MessageBox.Show("Custom Telnet prompt enabled");
}
```

#### Matlab

```
[status, port] = MyPTE1.TelnetPort_TelnetPromptEn()
if status > 0
    h = msgbox ("Custom Telnet prompt enabled")
end
```

### See Also

[Get Custom Telnet Prompt Text](#)

[Enable Custom Telnet Prompt](#)

[Set Custom Telnet Prompt Text](#)

## 4.8 (i) - Get Custom Telnet Prompt Text

### Declaration

```
int GetEthernet_TelnetPromptText (ByRef string PromptText)
```

### Description

Returns the text string (up to 10 characters) which will be used as a Telnet prompt when the custom prompt is enabled.

### Requirements

RC Series programmable attenuator with firmware D5 or above.

### Parameters

Data Type	Variable	Description
string	PromptText	The text string (up to 10 characters) to be used as a prompt during Telnet communication, or 1 of 2 special cases: <ol style="list-style-type: none"> <li><b>MN</b> - The device's model name will be used</li> <li><b>SN</b> - The device's serial number will be used</li> </ol>

### Return Values

Data Type	Value	Description
int	0	Command failed
int	1	Command completed successfully

### Example

#### Visual Basic

```
If MyPTE1.GetEthernet_TelnetPromptText(prompttext) > 0 Then
    MsgBox ("Prompt: " & prompttext)
End If
```

#### Visual C++

```
if (MyPTE1->GetEthernet_TelnetPromptText(prompttext) > 0)
{
    MessageBox::Show("Prompt: " + prompttext);
}
```

#### Visual C#

```
if (MyPTE1.GetEthernet_TelnetPromptText(ref(prompttext)) > 0)
{
    MessageBox.Show("Prompt: " + prompttext);
}
```

#### Matlab

```
[status, prompttext] = MyPTE1.GetEthernet_TelnetPromptText(prompttext)
if status > 0
    h = msgbox ("Prompt: ", prompttext)
end
```

### See Also

[Query Telnet Prompt Type](#)  
[Enable Custom Telnet Prompt](#)  
[Set Custom Telnet Prompt Text](#)

## 4.8 (j) - Get DHCP Status

### Declaration

```
int GetEthernet_UseDHCP ()
```

### Description

This function indicates whether the attenuator is using DHCP (dynamic host control protocol), in which case the IP configuration is derived from a network server; or user defined “static” IP settings.

### Parameters

Data Type	Variable	Description
None		

### Return Values

Data Type	Value	Description
int	0	DHCP not in use (IP settings are static and manually configured)
int	1	DHCP in use (IP settings are assigned automatically by the network)

### Example

#### Visual Basic

```
DHCPstatus = MyPTE1.GetEthernet_UseDHCP ()
```

#### Visual C++

```
DHCPstatus = MyPTE1->GetEthernet_UseDHCP ();
```

#### Visual C#

```
DHCPstatus = MyPTE1.GetEthernet_UseDHCP ();
```

#### Matlab

```
DHCPstatus = MyPTE1.GetEthernet_UseDHCP
```

### See Also

[Get Ethernet Configuration](#)

[Use DHCP](#)

## 4.8 (k) - Get Password Status

### Declaration

```
int GetEthernet_UsePWD ()
```

### Description

This function indicates whether the attenuator is currently configured to require a password for HTTP/Telnet communication.

### Parameters

Data Type	Variable	Description
None		

### Return Values

Data Type	Value	Description
int	0	Password not required
int	1	Password required

### Example

```

Visual Basic
    PWDstatus = MyPTE1.GetEthernet_UsePWD ()
Visual C++
    PWDstatus = MyPTE1->GetEthernet_UsePWD ();
Visual C#
    PWDstatus = MyPTE1.GetEthernet_UsePWD ();
Matlab
    PWDstatus = MyPTE1.GetEthernet_UsePWD
    
```

### See Also

- [Get Password](#)
- [Use Password](#)
- [Set Password](#)

## 4.8 (I) - Get Password

### Declaration

```
int GetEthernet_PWD (ByRef String Pwd)
```

### Description

Returns the password used by the attenuator for HTTP/Telnet communication. The password will be returned even if the device is not currently configured to require a password.

### Requirements

RC Series programmable attenuator with RJ45 network interface.

### Parameters

Data Type	Variable	Description
String	Pwd	Passed by reference, to be updated with the password

### Return Values

Data Type	Value	Description
int	0	Command failed
int	1	Command completed successfully

### Example

#### Visual Basic

```
If MyPTE1.GetEthernet_PWD(pwd) > 0 Then
    MsgBox ("Password: " & pwd)
End If
```

#### Visual C++

```
if (MyPTE1->GetEthernet_PWD(pwd) > 0) {
    MessageBox::Show("Password: " + pwd);
}
```

#### Visual C#

```
if (MyPTE1.GetEthernet_PWD(pwd) > 0) {
    MessageBox.Show("Password: " + pwd);
}
```

#### Matlab

```
[status, pwd] = MyPTE1.GetEthernet_PWD(pwd)
if status > 0
    h = msgbox ("Password: ", pwd)
end
```

### See Also

[Get Password Status](#)  
[Use Password](#)  
[Set Password](#)

## 4.8 (m) - Save IP Address

### Declaration

```
int SaveEthernet_IPAddress(int b1, int b2, int b3, int b4)
```

### Description

This function sets a static IP address to be used by the connected attenuator.

Note: this could subsequently be overwritten automatically if DHCP is enabled (see [Use DHCP](#)).

### Parameters

Data Type	Variable	Description
int	IP1	Required. First (highest order) octet of the IP address to set (for example "192" for the IP address "192.168.1.0").
int	IP2	Required. Second octet of the IP address to set (for example "168" for the IP address "192.168.1.0").
int	IP3	Required. Third octet of the IP address to set (for example "1" for the IP address "192.168.1.0").
int	IP4	Required. Last (lowest order) octet of the IP address to set (for example "0" for the IP address "192.168.1.0").

### Return Values

Data Type	Value	Description
int	0	Command failed
int	1	Command completed successfully

### Example

#### Visual Basic

```
status = MyPTE1.SaveEthernet_IPAddress(192, 168, 1, 0)
```

#### Visual C++

```
status = MyPTE1->SaveEthernet_IPAddress(192, 168, 1, 0);
```

#### Visual C#

```
status = MyPTE1.SaveEthernet_IPAddress(192, 168, 1, 0);
```

#### Matlab

```
status = MyPTE1.SaveEthernet_IPAddress(192, 168, 1, 0)
```

### See Also

[Get Ethernet Configuration](#)

[Get IP Address](#)

## 4.8 (n) - Save Network Gateway

### Declaration

```
int SaveEthernet_NetworkGateway(int b1, int b2, int b3, int b4)
```

### Description

This function sets the IP address of the network gateway to which the attenuator should connect.

Note: this could subsequently be overwritten automatically if DHCP is enabled (see [Use DHCP](#)).

### Parameters

Data Type	Variable	Description
int	IP1	Required. First (highest order) octet of the network gateway IP address (for example "192" for the IP address "192.168.1.0").
int	IP2	Required. Second octet of the network gateway IP address (for example "168" for the IP address "192.168.1.0").
int	IP3	Required. Third octet of the network gateway IP address (for example "1" for the IP address "192.168.1.0").
int	IP4	Required. Last (lowest order) octet of the network gateway IP address (for example "0" for the IP address "192.168.1.0").

### Return Values

Data Type	Value	Description
int	0	Command failed
int	1	Command completed successfully

### Example

#### Visual Basic

```
status = MyPTE1.SaveEthernet_NetworkGateway(192, 168, 1, 0)
```

#### Visual C++

```
status = MyPTE1->SaveEthernet_NetworkGateway(192, 168, 1, 0);
```

#### Visual C#

```
status = MyPTE1.SaveEthernet_NetworkGateway(192, 168, 1, 0);
```

#### Matlab

```
status = MyPTE1.SaveEthernet_NetworkGateway(192, 168, 1, 0)
```

### See Also

[Get Ethernet Configuration](#)

[Get Network Gateway](#)

## 4.8 (o) - Save Subnet Mask

### Declaration

```
int SaveEthernet_SubnetMask(int b1, int b2, int b3, int b4)
```

### Description

This function sets the subnet mask of the network to which the attenuator should connect.

Note: this could subsequently be overwritten automatically if DHCP is enabled (see [Use DHCP](#)).

### Parameters

Data Type	Variable	Description
int	IP1	Required. First (highest order) octet of the subnet mask (for example "255" for the subnet mask "255.255.255.0").
int	IP2	Required. Second octet of the subnet mask (for example "255" for the subnet mask "255.255.255.0").
int	IP2	Required. Third octet of the subnet mask (for example "255" for the subnet mask "255.255.255.0").
int	IP4	Required. Last (lowest order) octet of the subnet mask (for example "0" for the subnet mask "255.255.255.0").

### Return Values

Data Type	Value	Description
int	0	Command failed
int	1	Command completed successfully

### Example

#### Visual Basic

```
status = MyPTE1.SaveEthernet_SubnetMask(255, 255, 255, 0)
```

#### Visual C++

```
status = MyPTE1->SaveEthernet_SubnetMask(255, 255, 255, 0);
```

#### Visual C#

```
status = MyPTE1.SaveEthernet_SubnetMask(255, 255, 255, 0);
```

#### Matlab

```
status = MyPTE1.SaveEthernet_SubnetMask(255, 255, 255, 0)
```

### See Also

[Get Ethernet Configuration](#)

[Get Subnet Mask](#)

## 4.8 (p) - Save TCP/IP Port

### Declaration

```
int SaveEthernet_TCPIPPort(int port)
```

### Description

This function sets the TCP/IP port used by the attenuator for HTTP communication. The default is port 80.

Note: Port 23 is reserved for Telnet communication and cannot be set as the HTTP port.

### Parameters

Data Type	Variable	Description
int	port	Required. Numeric value of the TCP/IP port.

### Return Values

Data Type	Value	Description
int	0	Command failed
int	1	Command completed successfully

### Example

#### Visual Basic

```
status = MyPTE1.SaveEthernet_TCPIPPort(70)
```

#### Visual C++

```
status = MyPTE1->SaveEthernet_TCPIPPort(70);
```

#### Visual C#

```
status = MyPTE1.SaveEthernet_TCPIPPort(70);
```

#### Matlab

```
status = MyPTE1.SaveEthernet_TCPIPPort(70)
```

### See Also

[Get TCP/IP Port](#)  
[Save Telnet Port](#)

## 4.8 (q) - Save Telnet Port

### Declaration

```
int SaveEthernet_TelnetPort(int port)
```

### Description

This function sets the port used by the attenuator for Telnet communication. The default is port 23

### Applies To

RC series programmable attenuators with firmware C7 or later.

### Parameters

Data Type	Variable	Description
int	port	Required. Numeric value of the Telnet port.

### Return Values

Data Type	Value	Description
int	0	Command failed
int	1	Command completed successfully

### Example

```
Visual Basic  
status = MyPTE1.SaveEthernet_TelnetPort(22)  
Visual C++  
status = MyPTE1->SaveEthernet_TelnetPort(22);  
Visual C#  
status = MyPTE1.SaveEthernet_TelnetPort(22);  
Matlab  
status = MyPTE1.SaveEthernet_TelnetPort(22)
```

### See Also

[Save TCP/IP Port](#)  
[Get Telnet Port](#)

## 4.8 (r) - Enable Custom Telnet Prompt

### Declaration

```
int SaveEthernet_TelnetPromptEn(int en)
```

### Description

When enabled, a custom text string will be returned as a prompt when the attenuator is ready to receive the next Telnet command. The custom prompt is disabled by default so only a new line character is returned.

### Applies To

RC series programmable attenuators with firmware D5 or later.

### Parameters

Data Type	Variable	Description
int	en	0 = Custom Telnet prompt disabled (new line character will be returned) 1 = Custom Telnet prompt enabled (see <a href="#">Set Custom Telnet Prompt Text</a> to set the text)

### Return Values

Data Type	Value	Description
int	0	Command failed
int	1	Command completed successfully

### Example

#### Visual Basic

```
status = MyPTE1.SaveEthernet_TelnetPromptEn(1)
```

#### Visual C++

```
status = MyPTE1->SaveEthernet_TelnetPromptEn(1);
```

#### Visual C#

```
status = MyPTE1.SaveEthernet_TelnetPromptEn(1);
```

#### Matlab

```
status = MyPTE1.SaveEthernet_TelnetPromptEn(1)
```

### See Also

[Query Telnet Prompt Type](#)  
[Get Custom Telnet Prompt Text](#)  
[Set Custom Telnet Prompt Text](#)

## 4.8 (s) - Set Custom Telnet Prompt Text

### Declaration

```
int SaveEthernet_TelnetPromptText(string PromptText)
```

### Description

Sets the text string (up to 10 characters) which will be used as a Telnet prompt when the custom prompt is enabled.

### Applies To

RC series programmable attenuators with firmware D5 or later.

### Parameters

Data Type	Variable	Description
string	PromptText	A text string (up to 10 characters) to be used as a prompt during Telnet communication, or 1 of 2 special cases: <ol style="list-style-type: none"> <li>MN - The device's model name will be used</li> <li>SN - The device's serial number will be used</li> </ol>

### Return Values

Data Type	Value	Description
int	0	Command failed
int	1	Command completed successfully

### Example

#### Visual Basic

```
status = MyPTE1.SaveEthernet_TelnetPromptText("MN")
```

#### Visual C++

```
status = MyPTE1->SaveEthernet_TelnetPromptText("MN");
```

#### Visual C#

```
status = MyPTE1.SaveEthernet_TelnetPromptText("MN");
```

#### Matlab

```
status = MyPTE1.SaveEthernet_TelnetPromptText("MN")
```

### See Also

[Query Telnet Prompt Type](#)  
[Get Custom Telnet Prompt Text](#)  
[Enable Custom Telnet Prompt](#)

## 4.8 (t) - Use DHCP

### Declaration

```
int SaveEthernet_UseDHCP (int UseDHCP)
```

### Description

This function enables or disables DHCP (dynamic host control protocol). When enabled the IP configuration of the attenuator is assigned automatically by the network server; when disabled the user defined “static” IP settings apply.

### Parameters

Data Type	Variable	Description
int	UseDHCP	Required. Integer value to set the DHCP mode: 0 - DHCP disabled (static IP settings used) 1 - DHCP enabled (IP setting assigned by network)

### Return Values

Data Type	Value	Description
int	0	Command failed
int	1	Command completed successfully

### Example

```

Visual Basic
    status = MyPTE1.SaveEthernet_UseDHCP (1)
Visual C++
    status = MyPTE1->SaveEthernet_UseDHCP (1) ;
Visual C#
    status = MyPTE1.SaveEthernet_UseDHCP (1) ;
Matlab
    status = MyPTE1.SaveEthernet_UseDHCP (1)

```

### See Also

[Get DHCP Status](#)

## 4.8 (u) - Use Password

### Declaration

```
int SaveEthernet_UsePWD (int UsePwd)
```

### Description

This function enables or disables the password requirement for HTTP/Telnet communication with the attenuator.

### Parameters

Data Type	Variable	Description
int	UseDHCP	Required. Integer value to set the password mode: 0 – Password not required 1 – Password required

### Return Values

Data Type	Value	Description
int	0	Command failed
int	1	Command completed successfully

### Example

#### Visual Basic

```
status = MyPTE1.SaveEthernet_UsePWD(1)
```

#### Visual C++

```
status = MyPTE1->SaveEthernet_UsePWD(1);
```

#### Visual C#

```
status = MyPTE1.SaveEthernet_UsePWD(1);
```

#### Matlab

```
status = MyPTE1.SaveEthernet_UsePWD(1)
```

### See Also

[Get Password Status](#)

[Get Password](#)

[Set Password](#)

## 4.8 (v) - Set Password

### Declaration

```
int SaveEthernet_PWD (String Pwd)
```

### Description

This function sets the password used by the attenuator for HTTP/Telnet communication. The password will not affect attenuator operation unless [Use Password](#) is also enabled.

### Parameters

Data Type	Variable	Description
String	Pwd	Required. The password to set (20 characters maximum).

### Return Values

Data Type	Value	Description
int	0	Command failed
int	1	Command completed successfully

### Example

```

Visual Basic
    status = MyPTE1.SaveEthernet_PWD ("123")
Visual C++
    status = MyPTE1->SaveEthernet_PWD ("123");
Visual C#
    status = MyPTE1.SaveEthernet_PWD ("123");
Matlab
    status = MyPTE1.SaveEthernet_PWD ("123")

```

### See Also

- [Get Password Status](#)
- [Get Password](#)
- [Use Password](#)

## 4.8 (w) - Enable / Disable Ethernet Interface

### Declaration

```
int SaveEthernet_EnableEthernet(int EnableEth)
```

### Description

Enables or disables the Ethernet interface. Disabling the Ethernet interface reduces current consumption of RCDAT-30G-30 / RCDAT-40G-30 attenuators but further communication would only be possible by USB.

### Requirements

RCDAT-30G-30 / RCDAT-40G-30

### Parameters

Data Type	Variable	Description
int	EnableEth	Required. Integer value to enable (1) or disable (0) the Ethernet interface.

### Return Values

Data Type	Value	Description
int	0	Command failed
int	1	Command completed successfully

### Example

#### Visual Basic

```
status = MyPTE1.SaveEthernet_EnableEthernet(1)
```

#### Visual C++

```
status = MyPTE1->SaveEthernet_EnableEthernet(1);
```

#### Visual C#

```
status = MyPTE1.SaveEthernet_EnableEthernet(1);
```

#### Matlab

```
status = MyPTE1.SaveEthernet_EnableEthernet(1)
```

### See Also

[Check Ethernet Interface](#)

## 4.8 (x) - Check Ethernet Interface

### Declaration

```
int GetEthernet_EnableEthernet ()
```

### Description

Indicates whether or not the Ethernet interface is enabled. When disabled, communication will only be possible with the USB connection to the attenuator.

### Requirements

RCDAT-30G-30 / RCDAT-40G-30

### Return Values

Data Type	Value	Description
int	0	Ethernet interface disabled
int	1	Ethernet interface enabled

### Example

```
Visual Basic  
status = MyPTE1.GetEthernet_EnableEthernet ()  
Visual C++  
status = MyPTE1->GetEthernet_EnableEthernet ();  
Visual C#  
status = MyPTE1.GetEthernet_EnableEthernet ();  
Matlab  
status = MyPTE1.GetEthernet_EnableEthernet ()
```

### See Also

[Enable / Disable Ethernet Interface](#)

## 4.9 - DLL Function Explanations - Attenuation Hopping

Once an attenuation sequence is programmed and enabled, it is managed by the attenuator's internal microprocessor; this supports very fast sequences with minimum dwell times in the order of 600  $\mu$ s. It is not possible to query any attenuator parameters whilst the sequence is active so any subsequent command / query to the device will disable the sequence.

An alternative implementation method is to control the sequence and timing from your program, only sending "set attenuation" commands to the attenuator at the appropriate times. The advantage of this approach is that the program is able to query and keep track of the current attenuation state. The disadvantage is that the communication delays inherent in USB / Ethernet communication dictate a minimum dwell time in the order of milliseconds with this approach, rather than microseconds.

## 4.9 (a) - Hop Mode - Set Number of Points

### Declaration

```
int Hop_SetNoOfPoints (int NoOfPoints)
```

### Description

Sets the number of points to be used in the attenuation hop sequence.

### Requirements

Model Name	Serial Number	Firmware
RC8DAT-8G-95	All	H4 or later
RC4DAT-8G-95	Up to 11910159999	E9 or later
	From 12001010001	H4 or later
RC4DAT-6G-95	Up to 11910299999	E9 or later
	From 11910300001	H4 or later
RC4DAT-6G-60	Up to 12007129999	E9 or later
	From 12007130001	H4 or later
RC4DAT-6G-30	Up to 12007129999	E9 or later
	From 12007239999	H4 or later
RCDAT, RUDAT & ZVVA series	All	E9 or later

### Parameters

Data Type	Variable	Description
int	NoOfPoints	The number of points to set in the hop sequence

### Return Values

Data Type	Value	Description
int	0	Command failed
	1	Command completed successfully

### Examples

#### Visual Basic

```
Status = MyPTE1.Hop_SetNoOfPoints(3)
```

#### Visual C++

```
Status = MyPTE1->Hop_SetNoOfPoints(3);
```

#### Visual C#

```
Status = MyPTE1.Hop_SetNoOfPoints(3);
```

#### Matlab

```
Status = MyPTE1.Hop_SetNoOfPoints(3)
```

### See Also

[Hop Mode - Get Number of Points](#)

[Hop Mode - Get Maximum Number of Points](#)

## 4.9 (b) - Hop Mode - Get Number of Points

### Declaration

```
int Hop_GetNoOfPoints ()
```

### Description

Returns the number of points to be used in the attenuation hop sequence.

### Requirements

Model Name	Serial Number	Firmware
RC8DAT-8G-95	All	H4 or later
RC4DAT-8G-95	Up to 11910159999	E9 or later
	From 12001010001	H4 or later
RC4DAT-6G-95	Up to 11910299999	E9 or later
	From 11910300001	H4 or later
RC4DAT-6G-60	Up to 12007129999	E9 or later
	From 12007130001	H4 or later
RC4DAT-6G-30	Up to 12007129999	E9 or later
	From 12007239999	H4 or later
RCDAT, RUDAT & ZVVA series	All	E9 or later

### Parameters

Data Type	Variable	Description
none		

### Return Values

Data Type	Value	Description
int	1 - 1000	The number of points in the hop sequence

### Examples

#### Visual Basic

```
Points = MyPTE1.Hop_GetNoOfPoints ()
```

#### Visual C++

```
Points = MyPTE1->Hop_GetNoOfPoints ();
```

#### Visual C#

```
Points = MyPTE1.Hop_GetNoOfPoints ();
```

#### Matlab

```
Points = MyPTE1.Hop_GetNoOfPoints ()
```

### See Also

[Hop Mode - Set Number of Points](#)

[Hop Mode - Get Maximum Number of Points](#)

## 4.9 (c) - Hop Mode - Get Maximum Number of Points

### Declaration

```
int Hop_GetMaxNoOfPoints ()
```

### Description

Returns the maximum number of points that can be used in the attenuation hop sequence.

### Requirements

Model Name	Serial Number	Firmware
RC8DAT-8G-95	All	H4 or later
RC4DAT-8G-95	Up to 11910159999	E9 or later
	From 12001010001	H4 or later
RC4DAT-6G-95	Up to 11910299999	E9 or later
	From 11910300001	H4 or later
RC4DAT-6G-60	Up to 12007129999	E9 or later
	From 12007130001	H4 or later
RC4DAT-6G-30	Up to 12007129999	E9 or later
	From 12007239999	H4 or later
RCDAT, RUDAT & ZVVA series	All	E9 or later

### Parameters

Data Type	Variable	Description
none		

### Return Values

Data Type	Value	Description
int	MaxPoints	The maximum number of hop points

### Examples

```

Visual Basic
    MaxPoints = MyPTE1.Hop_GetMaxNoOfPoints ()

Visual C++
    MaxPoints = MyPTE1->Hop_GetMaxNoOfPoints ();

Visual C#
    MaxPoints = MyPTE1.Hop_GetMaxNoOfPoints ();

Matlab
    MaxPoints = MyPTE1.Hop_GetMaxNoOfPoints ()
    
```

### See Also

[Hop Mode - Set Number of Points](#)

[Hop Mode - Get Number of Points](#)

## 4.9 (d) - Hop Mode - Set Sequence Direction

```
int Hop_SetDirection(int Direction)
```

### Description

Sets the direction in which the attenuator will progress through the list of attenuation hops.

### Requirements

Model Name	Serial Number	Firmware
RC8DAT-8G-95	All	All
RC4DAT-8G-95	Up to 11910159999	B1 or later
	From 12001010001	All
RC4DAT-6G-95	Up to 11910299999	B1 or later
	From 11910300001	All
RC4DAT-6G-60	Up to 12007129999	B1 or later
	From 12007130001	All
RC4DAT-6G-30	Up to 12007129999	B1 or later
	From 12007239999	All
RCDAT, RUDAT & ZVVA series	All	B1 or later

### Parameters

Data Type	Variable	Description
int	Direction	Numeric value indicating the direction: 0 = Forward - The list of attenuation hops will be loaded from index 1 to index n 1 = Backwards - The list of attenuation hops will be loaded from index n to index 1 2 = Bi-directionally - The list of attenuation hops will be loaded in the forward and then reverse directions

### Return Values

Data Type	Value	Description
int	0	Command failed
	1	Command completed successfully

### Examples

#### Visual Basic

```
Status = MyPTE1.Hop_SetDirection(1)
```

#### Visual C++

```
Status = MyPTE1->Hop_SetDirection(1);
```

#### Visual C#

```
Status = MyPTE1.Hop_SetDirection(1);
```

#### Matlab

```
Status = MyPTE1.Hop_SetDirection(1)
```

### See Also

[Hop Mode - Get Sequence Direction](#)

## 4.9 (e) - Hop Mode - Get Sequence Direction

```
int Hop_GetDirection()
```

### Description

Returns the direction in which the attenuator will progress through the list of attenuation hops.

### Requirements

Model Name	Serial Number	Firmware
RC8DAT-8G-95	All	All
RC4DAT-8G-95	Up to 11910159999	B1 or later
	From 12001010001	All
RC4DAT-6G-95	Up to 11910299999	B1 or later
	From 11910300001	All
RC4DAT-6G-60	Up to 12007129999	B1 or later
	From 12007130001	All
RC4DAT-6G-30	Up to 12007129999	B1 or later
	From 12007239999	All
RCDAT, RUDAT & ZVVA series	All	B1 or later

### Parameters

Data Type	Variable	Description
none		

### Return Values

Data Type	Value	Description
int	0	Forward - The list of attenuation hops will be loaded from index 1 to index n
	1	Backwards - The list of attenuation hops will be loaded from index n to index 1
	2	Bi-directionally - The list of attenuation hops will be loaded in the forward and then reverse directions

### Examples

#### Visual Basic

```
Points = MyPTE1.Hop_GetDirection()
```

#### Visual C++

```
Points = MyPTE1->Hop_GetDirection();
```

#### Visual C#

```
Points = MyPTE1.Hop_GetDirection();
```

#### Matlab

```
Points = MyPTE1.Hop_GetDirection()
```

### See Also

[Hop Mode - Set Sequence Direction](#)

## 4.9 (f) - Hop Mode - Get Maximum Dwell Time

```
int Hop_GetMaxDwell ()
```

### Description

Returns the maximum dwell time that can be used for any point in the attenuation hop sequence.

### Requirements

Model Name	Serial Number	Firmware
RC8DAT-8G-95	All	All
RC4DAT-8G-95	Up to 11910159999	B1 or later
	From 12001010001	All
RC4DAT-6G-95	Up to 11910299999	B1 or later
	From 11910300001	All
RC4DAT-6G-60	Up to 12007129999	B1 or later
	From 12007130001	All
RC4DAT-6G-30	Up to 12007129999	B1 or later
	From 12007239999	All
RCDAT, RUDAT & ZVVA series	All	B1 or later

### Parameters

Data Type	Variable	Description
none		

### Return Values

Data Type	Value	Description
int	MaxDwell	Maximum hop dwell time

### Examples

#### Visual Basic

```
MaxDwell = MyPTE1.Hop_GetMaxDwell ()
```

#### Visual C++

```
MaxDwell = MyPTE1->Hop_GetMaxDwell ();
```

#### Visual C#

```
MaxDwell = MyPTE1.Hop_GetMaxDwell ();
```

#### Matlab

```
MaxDwell = MyPTE1.Hop_GetMaxDwell ()
```

### See Also

[Hop Mode - Get Minimum Dwell Time](#)

## 4.9 (g) - Hop Mode - Get Minimum Dwell Time

```
int Hop_GetMinDwell ()
```

### Description

Returns the minimum dwell time that can be used for any point in the attenuation hop sequence.

### Requirements

Model Name	Serial Number	Firmware
RC8DAT-8G-95	All	All
RC4DAT-8G-95	Up to 11910159999	B1 or later
	From 12001010001	All
RC4DAT-6G-95	Up to 11910299999	B1 or later
	From 11910300001	All
RC4DAT-6G-60	Up to 12007129999	B1 or later
	From 12007130001	All
RC4DAT-6G-30	Up to 12007129999	B1 or later
	From 12007239999	All
RCDAT, RUDAT & ZVVA series	All	B1 or later

### Parameters

Data Type	Variable	Description
none		

### Return Values

Data Type	Value	Description
int	MinDwell	Minimum hop dwell time

### Examples

#### Visual Basic

```
MinDwell = MyPTE1.Hop_GetMinDwell ()
```

#### Visual C++

```
MinDwell = MyPTE1->Hop_GetMinDwell ();
```

#### Visual C#

```
MinDwell = MyPTE1.Hop_GetMinDwell ();
```

#### Matlab

```
MinDwell = MyPTE1.Hop_GetMinDwell ()
```

### See Also

[Hop Mode - Get Maximum Dwell Time](#)

## 4.9 (h) - Hop Mode - Single Channel - Set Hop

```
int Hop_SetPoint(int Point, single Att, int Dwell, int Dw_Units)
```

### Description

Sets the attenuation level and dwell time for a specific point with in the hop sequence of a single channel (ZVVA / RUDAT / RCDAT) attenuator.

### Applies To

Model Name	Serial Number	Firmware
RCDAT, RUDAT & ZVVA series	All	B1 or later

### Parameters

Data Type	Variable	Description
int	Point	The index number of the point within the sequence (from 1 to the number of points set)
single	Att	The attenuation level to set for this point
int	Dwell	The dwell time for this point
int	Dw_Units	Numeric code indicating the dwell time units: 117 = Dwell time in microseconds ( $\mu$ s) 109 = Dwell time in milliseconds (ms) 115 = Dwell time in seconds (s)

### Return Values

Data Type	Value	Description
int	0	Command failed
	1	Command completed successfully

### Examples

#### Visual Basic

```
Status = MyPTE1.Hop_SetPoint(1, 10.75, 600, 115)
```

#### Visual C++

```
Status = MyPTE1->Hop_SetPoint(1, 10.75, 600, 115);
```

#### Visual C#

```
Status = MyPTE1.Hop_SetPoint(1, 10.75, 600, 115);
```

#### Matlab

```
Status = MyPTE1.Hop_SetPoint(1, 10.75, 600, 115)
```

### See Also

[Hop Mode - Single Channel - Get Hop](#)

## 4.9 (i) - Hop Mode - Single Channel - Get Hop

### Declaration

```
int Hop_GetPoint(int Point, ByRef single Att, ByRef int Dwell,
                ByRef int Dw_Units)
```

### Description

Gets the attenuation level and dwell time for a specific point with in the hop sequence of a single channel (ZVVA / RUDAT / RCDAT) attenuator.

### Applies To

Model Name	Serial Number	Firmware
RCDAT, RUDAT & ZVVA series	All	B1 or later

### Parameters

Data Type	Variable	Description
int	Point	The index number of the point within the sequence (from 1 to the number of points set)
single	Att	Variable passed by reference to be updated with the attenuation level set for this point
int	Dwell	Variable passed by reference to be updated with the dwell time set for this point
int	Dw_Units	Variable passed by reference to be updated with a numeric code indicating the dwell time units for this point: 117 = Dwell time in microseconds ( $\mu$ s) 109 = Dwell time in milliseconds (ms) 115 = Dwell time in seconds (s)

### Return Values

Data Type	Value	Description
int	0	Command failed
	1	Command completed successfully

### Examples

#### Visual Basic

```
Status = MyPTE1.Hop_GetPoint(1, Att, Dwell, Dw_Units)
```

#### Visual C++

```
Status = MyPTE1->Hop_GetPoint(1, Att, Dwell, Dw_Units);
```

#### Visual C#

```
Status = MyPTE1.Hop_GetPoint(1, Att, Dwell, Dw_Units);
```

#### Matlab

```
[Status, Att, Dwell, Dw_Units] = MyPTE1.Hop_GetPoint(1, Att, Dwell, Dw_Units)
```

### See Also

[Hop Mode - Single Channel - Set Hop](#)

## 4.9 (j) - Hop Mode - Multi-Channel - Set Active Channels

### Declaration

```
int Hop_SetActiveChannels (int CH1_YesNo, int CH2_YesNo,
                           int CH3_YesNo, int CH4_YesNo)
```

### Description

Sets which of the 4 channels of a multi-channel attenuator are to be included in the attenuation hop sequence.

### Applies To

RC4DAT Series

### Parameters

Data Type	Variable	Description
int	CH1_YesNo	1 to include CH1 in the hop, 0 to leave unchanged
int	CH2_YesNo	1 to include CH2 in the hop, 0 to leave unchanged
int	CH3_YesNo	1 to include CH3 in the hop, 0 to leave unchanged
int	CH4_YesNo	1 to include CH4 in the hop, 0 to leave unchanged

### Return Values

Data Type	Value	Description
int	0	Command failed
	1	Command completed successfully

### Examples

#### Visual Basic

```
Status = MyPTE1.Hop_SetActiveChannels(1, 1, 0, 0)
' Configure a hop for channels 1 and 2 only
```

#### Visual C++

```
Status = MyPTE1->Hop_SetActiveChannels(1, 1, 0, 0);
// Configure a hop for channels 1 and 2 only
```

#### Visual C#

```
Status = MyPTE1.Hop_SetActiveChannels(1, 1, 0, 0);
// Configure a hop for channels 1 and 2 only
```

#### Matlab

```
Status = MyPTE1.Hop_SetActiveChannels(1, 1, 0, 0)
% Configure a hop for channels 1 and 2 only
```

### See Also

[Hop Mode - Multi-Channel - Get Active Channels](#)

## 4.9 (k) - Hop Mode - Multi-Channel - Get Active Channels

### Declaration

```
int Hop_GetActiveChannels (ByRef int CH1_YesNo, ByRef int CH2_YesNo,
                          ByRef int CH3_YesNo, ByRef int CH4_YesNo)
```

### Description

Checks which of the 4 channels of a multi-channel attenuator are to be included in the attenuation hop sequence.

### Applies To

RC4DAT Series

### Parameters

Data Type	Variable	Description
int	CH1_YesNo	Reference to a variable which will be updated with the status of CH1 (1 if it included in the hop, 0 otherwise)
int	CH2_YesNo	Reference to a variable which will be updated with the status of CH2 (1 if it included in the hop, 0 otherwise)
int	CH3_YesNo	Reference to a variable which will be updated with the status of CH3 (1 if it included in the hop, 0 otherwise)
int	CH4_YesNo	Reference to a variable which will be updated with the status of CH4 (1 if it included in the hop, 0 otherwise)

### Return Values

Data Type	Value	Description
int	0	Command failed
	1	Command completed successfully

### Examples

#### Visual Basic

```
Status = MyPTE1.Hop_GetActiveChannels(CH1, CH2, CH3, CH4)
' Check which channels are to be included in the hop
```

#### Visual C++

```
Status = MyPTE1->Hop_GetActiveChannels(CH1, CH2, CH3, CH4);
// Check which channels are to be included in the hop
```

#### Visual C#

```
Status=MyPTE1.Hop_GetActiveChannels(ref(CH1),ref(CH2),ref(CH3),ref(CH4));
// Check which channels are to be included in the hop
```

#### Matlab

```
[Status,CH1,CH2,CH3,CH4]=MyPTE1.Hop_GetActiveChannels(CH1, CH2, CH3, CH4)
% Check which channels are to be included in the hop
```

### See Also

[Hop Mode - Multi-Channel - Set Active Channels](#)

## 4.9 (I) - Hop Mode - Multi-Channel Hop - Set Hop Point for All Channels

### Declaration

```
int Hop_SetPoint4Channels(int PointNo, float HopAtt1, float HopAtt2,
                        float HopAtt3, float HopAtt4, int Dwell, int DwellUnits)
```

### Description

Sets the attenuation values to be loaded for each channel and the dwell time for a specific point within the hop sequence.

### Applies To

RC4DAT Series

### Parameters

Data Type	Variable	Description
int	PointNo	The ndex number of the hop within the hop sequence
float	HopAtt1	Attenuation to set for CH1 at this point in the hop sequence
float	HopAtt2	Attenuation to set for CH2 at this point in the hop sequence
float	HopAtt3	Attenuation to set for CH3 at this point in the hop sequence
float	HopAtt4	Attenuation to set for CH4 at this point in the hop sequence
int	Dwell	The dwell time for this point in the hop sequence
int	DwellUnits	Numeric code indicating the dwell time units: 117 = Dwell time in microseconds ( $\mu$ s) 109 = Dwell time in milliseconds (ms) 115 = Dwell time in seconds (s)

### Return Values

Data Type	Value	Description
int	0	Command failed
	1	Command completed successfully

### Examples

#### Visual Basic

```
Status = MyPTE1.Hop_SetPoint4Channels(2, 20.25, 10.75, 0, 0, 20, 109)
' Set the attenuation values with 20 ms dwell time for hop point 2
```

#### Visual C++

```
Status = MyPTE1->Hop_SetPoint4Channels(2, 20.25, 10.75, 0, 0, 20, 109);
// Set the attenuation values with 20 ms dwell time for hop point 2
```

#### Visual C#

```
Status = MyPTE1.Hop_SetPoint4Channels(2, 20.25, 10.75, 0, 0, 20, 109);
// Set the attenuation values with 20 ms dwell time for hop point 2
```

#### Matlab

```
Status = MyPTE1.Hop_SetPoint4Channels(2, 20.25, 10.75, 0, 0, 20, 109)
% Set the attenuation values with 20 ms dwell time for hop point 2
```

### See Also

[Hop Mode - Multi-Channel - Get Hop Point for All Channels](#)

## 4.9 (m) - Hop Mode - Multi-Channel - Get Hop Point for All Channels

### Declaration

```
int Hop_GetPoint4Channels(int PointNo, ByRef float HopAtt1,
                          ByRef float HopAtt2, ByRef float HopAtt3, ByRef float HopAtt4,
                          ByRef int Dwell, ByRef int DwellUnits)
```

### Description

Returns the attenuation values to be loaded for each channel and the dwell time for a specific point within the hop sequence.

### Applies To

RC4DAT Series

### Parameters

Data Type	Variable	Description
int	PointNo	The index number of the hop within the hop sequence
float	HopAtt1	Reference to a variable which will be updated with the attenuation for CH1 at this point in the hop sequence
float	HopAtt2	Reference to a variable which will be updated with the attenuation for CH2 at this point in the hop sequence
float	HopAtt3	Reference to a variable which will be updated with the attenuation for CH3 at this point in the hop sequence
float	HopAtt4	Reference to a variable which will be updated with the attenuation for CH4 at this point in the hop sequence
int	Dwell	Reference to a variable which will be updated with the dwell time for this point in the hop sequence
int	DwellUnits	Reference to a variable which will be updated with a numeric code indicating the dwell time units: 117 = Dwell time in microseconds ( $\mu$ s) 109 = Dwell time in milliseconds (ms) 115 = Dwell time in seconds (s)

### Return Values

Data Type	Value	Description
int	0	Command failed
	1	Command completed successfully

## Examples

### Visual Basic

```
Status = MyPTE1.Hop_GetPoint4Channels(2, CH1, CH2, CH3, CH4, DWT, DWTU)  
' Get the details for point 2 in the hop sequence
```

### Visual C++

```
Status = MyPTE1->Hop_GetPoint4Channels(2, CH1, CH2, CH3, CH4, DWT, DWTU);  
// Get the details for point 2 in the hop sequence
```

### Visual C#

```
Status  
=MyPTE1.Hop_GetPoint4Channels(ref(CH1),ref(CH2),ref(CH3),ref(CH4),  
                                ref(DWT),ref(DWTU));  
  
// Get the details for point 2 in the hop sequence
```

### Matlab

```
[Status, CH1, CH2, CH3, CH4, DWT, DWTU]  
= MyPTE1.Hop_GetPoint4Channels(2, CH1, CH2, CH3, CH4, DWT, DWTU)  
% Get the details for point 2 in the hop sequence
```

## See Also

[Hop Mode - Multi-Channel Hop - Set Hop Point for All Channels](#)

## 4.9 (n) - Hop Mode - Turn On / Off

```
int Hop_SetMode(int On_Off)
```

### Description

Enables or disables the hop sequence according to the previously configured parameters.

Once an attenuation sequence is programmed and enabled, it is managed by the attenuator's internal microprocessor; this supports very fast sequences with minimum dwell times in the order of 600  $\mu$ s. It is not possible to query any attenuator parameters whilst the sequence is active so any subsequent command / query to the device will disable the sequence.

An alternative implementation method is to control the sequence and timing from your program, only sending "set attenuation" commands to the attenuator at the appropriate times. The advantage of this approach is that the program is able to query and keep track of the current attenuation state. The disadvantage is that the communication delays inherent in USB / Ethernet communication dictate a minimum dwell time in the order of milliseconds with this approach, rather than microseconds.

### Requirements

Model Name	Serial Number	Firmware
RC8DAT-8G-95	All	All
RC4DAT-8G-95	Up to 11910159999	B1 or later
	From 12001010001	All
RC4DAT-6G-95	Up to 11910299999	B1 or later
	From 11910300001	All
RC4DAT-6G-60	Up to 12007129999	B1 or later
	From 12007130001	All
RC4DAT-6G-30	Up to 12007129999	B1 or later
	From 12007239999	All
RCDAT, RUDAT & ZVVA series	All	B1 or later

### Parameters

Data Type	Variable	Description
int	On_Off	Numeric value to enable/disable the hop sequence: 0 = Disable the hop sequence 1 = Enable the hop sequence

### Return Values

Data Type	Value	Description
int	0	Command failed
	1	Command completed successfully

## Examples

**Visual Basic**

```
Status = MyPTE1.Hop_SetMode(1)
```

**Visual C++**

```
Status = MyPTE1->Hop_SetMode(1);
```

**Visual C#**

```
Status = MyPTE1.Hop_SetMode(1);
```

**Matlab**

```
Status = MyPTE1.Hop_SetMode(1)
```

## 4.10 - DLL Function Explanations - Attenuation Sweeping / Fading

Once an attenuation sequence is programmed and enabled, it is managed by the attenuator's internal microprocessor; this supports very fast sequences with minimum dwell times in the order of 600  $\mu$ s. It is not possible to query any attenuator parameters whilst the sequence is active so any subsequent command / query to the device will disable the sequence.

An alternative implementation method is to control the sequence and timing from your program, only sending "set attenuation" commands to the attenuator at the appropriate times. The advantage of this approach is that the program is able to query and keep track of the current attenuation state. The disadvantage is that the communication delays inherent in USB / Ethernet communication dictate a minimum dwell time in the order of milliseconds with this approach, rather than microseconds.

## 4.10 (a) - Sweep Mode - Set Sweep Direction

```
int Sweep_SetDirection(int Direction)
```

### Description

Sets the direction in which the attenuator will sweep between the start and stop attenuation values.

### Requirements

Model Name	Serial Number	Firmware
RC8DAT-8G-95	All	All
RC4DAT-8G-95	Up to 11910159999	B1 or later
	From 12001010001	All
RC4DAT-6G-95	Up to 11910299999	B1 or later
	From 11910300001	All
RC4DAT-6G-60	Up to 12007129999	B1 or later
	From 12007130001	All
RC4DAT-6G-30	Up to 12007129999	B1 or later
	From 12007239999	All
RCDAT, RUDAT & ZVVA series	All	B1 or later

### Parameters

Data Type	Variable	Description
int	Direction	Numeric value indicating the direction: 0 = Forward - Sweep from start to stop attenuation 1 = Backwards - Sweep from stop to start attenuation 2 = Bi-directionally - Sweep in the forward and then reverse directions

### Return Values

Data Type	Value	Description
int	0	Command failed
	1	Command completed successfully

### Examples

#### Visual Basic

```
Status = MyPTE1.Sweep_SetDirection(1)
```

#### Visual C++

```
Status = MyPTE1->Sweep_SetDirection(1);
```

#### Visual C#

```
Status = MyPTE1.Sweep_SetDirection(1);
```

#### Matlab

```
Status = MyPTE1.Sweep_SetDirection(1)
```

### See Also

[Sweep Mode - Get Sweep Direction](#)

## 4.10 (b) - Sweep Mode - Get Sweep Direction

```
int Sweep_GetDirection()
```

### Description

Returns the direction in which the attenuator will sweep between the start and stop attenuation values.

### Requirements

Model Name	Serial Number	Firmware
RC8DAT-8G-95	All	All
RC4DAT-8G-95	Up to 11910159999	B1 or later
	From 12001010001	All
RC4DAT-6G-95	Up to 11910299999	B1 or later
	From 11910300001	All
RC4DAT-6G-60	Up to 12007129999	B1 or later
	From 12007130001	All
RC4DAT-6G-30	Up to 12007129999	B1 or later
	From 12007239999	All
RCDAT, RUDAT & ZVVA series	All	B1 or later

### Parameters

Data Type	Variable	Description
none		

### Return Values

Data Type	Value	Description
int	0	Forward - Sweep from start to stop attenuation
	1	Backwards - Sweep from stop to start attenuation
	2	Bi-directionally - Sweep in the forward and then reverse directions

### Examples

#### Visual Basic

```
Points = MyPTE1.Sweep_GetDirection()
```

#### Visual C++

```
Points = MyPTE1->Sweep_GetDirection();
```

#### Visual C#

```
Points = MyPTE1.Sweep_GetDirection();
```

#### Matlab

```
Points = MyPTE1.Sweep_GetDirection()
```

### See Also

[Sweep Mode - Set Sweep Direction](#)

## 4.10 (c) - Sweep Mode - Set Dwell Time

```
int Sweep_SetDwell(int Dwell, int Dwell_Units)
```

### Description

Sets the dwell time to be used for each attenuation step within the sweep.

### Requirements

Model Name	Serial Number	Firmware
RC8DAT-8G-95	All	All
RC4DAT-8G-95	Up to 11910159999	B1 or later
	From 12001010001	All
RC4DAT-6G-95	Up to 11910299999	B1 or later
	From 11910300001	All
RC4DAT-6G-60	Up to 12007129999	B1 or later
	From 12007130001	All
RC4DAT-6G-30	Up to 12007129999	B1 or later
	From 12007239999	All
RCDAT, RUDAT & ZVVA series	All	B1 or later

### Parameters

Data Type	Variable	Description
int	Dwell	The dwell time
int	Dwell_Units	Numeric code indicating the dwell time units: 117 = Dwell time in microseconds ( $\mu$ s) 109 = Dwell time in milliseconds (ms) 115 = Dwell time in seconds (s)

### Return Values

Data Type	Value	Description
int	0	Command failed
	1	Command completed successfully

### Examples

#### Visual Basic

```
Status = MyPTE1.Sweep_SetDwell(650, 117)
```

#### Visual C++

```
Status = MyPTE1->Sweep_SetDwell(650, 117);
```

#### Visual C#

```
Status = MyPTE1.Sweep_SetDwell(650, 117);
```

#### Matlab

```
Status = MyPTE1.Sweep_SetDwell(650, 117)
```

### See Also

[Sweep Mode - Get Dwell Time](#)

[Sweep Mode - Get Maximum Dwell Time](#)

[Sweep Mode - Get Minimum Dwell Time](#)

#### 4.10 (d) - Sweep Mode - Get Dwell Time

```
int Sweep_GetDwell (ByRef int Dwell, ByRef int Dwell_Units)
```

#### Description

Returns the dwell time to be used for each attenuation step within the sweep.

#### Requirements

Model Name	Serial Number	Firmware
RC8DAT-8G-95	All	All
RC4DAT-8G-95	Up to 11910159999	B1 or later
	From 12001010001	All
RC4DAT-6G-95	Up to 11910299999	B1 or later
	From 11910300001	All
RC4DAT-6G-60	Up to 12007129999	B1 or later
	From 12007130001	All
RC4DAT-6G-30	Up to 12007129999	B1 or later
	From 12007239999	All
RCDAT, RUDAT & ZVVA series	All	B1 or later

#### Parameters

Data Type	Variable	Description
int	Dwell	Variable passed by reference, to be updated with the dwell time
int	Dwell_Units	Variable passed by reference, to be updated with a numeric value indicating the dwell time units: 117 = Dwell time in microseconds ( $\mu$ s) 109 = Dwell time in milliseconds (ms) 115 = Dwell time in seconds (s)

#### Return Values

Data Type	Value	Description
int	0	Command failed
	1	Command completed successfully

#### Examples

```

Visual Basic
    Status = MyPTE1.Sweep_GetDwell(Dwell, Dw_Units)
Visual C++
    Status = MyPTE1->Sweep_GetDwell(Dwell, Dw_Units);
Visual C#
    Status = MyPTE1.Sweep_GetDwell(Dwell, Dw_Units);
Matlab
    [Status, Dwell, Dw_Units] = MyPTE1.Sweep_GetDwell(Dwell, Dw_Units)
    
```

**See Also**

[Sweep Mode - Set Dwell Time](#)

[Sweep Mode - Get Maximum Dwell Time](#)

[Sweep Mode - Get Minimum Dwell Time](#)

## 4.10 (e) - Sweep Mode - Get Maximum Dwell Time

```
int Sweep_GetMaxDwell ()
```

### Description

Returns the maximum dwell time that can be used for each attenuation step within the sweep.

### Requirements

Model Name	Serial Number	Firmware
RC8DAT-8G-95	All	All
RC4DAT-8G-95	Up to 11910159999	B1 or later
	From 12001010001	All
RC4DAT-6G-95	Up to 11910299999	B1 or later
	From 11910300001	All
RC4DAT-6G-60	Up to 12007129999	B1 or later
	From 12007130001	All
RC4DAT-6G-30	Up to 12007129999	B1 or later
	From 12007239999	All
RCDAT, RUDAT & ZVVA series	All	B1 or later

### Parameters

Data Type	Variable	Description
none		

### Return Values

Data Type	Value	Description
int	MaxDwell	Maximum sweep dwell time

### Examples

#### Visual Basic

```
MaxDwell = MyPTE1.Sweep_GetMaxDwell ()
```

#### Visual C++

```
MaxDwell = MyPTE1->Sweep_GetMaxDwell ();
```

#### Visual C#

```
MaxDwell = MyPTE1.Sweep_GetMaxDwell ();
```

#### Matlab

```
MaxDwell = MyPTE1.Sweep_GetMaxDwell ()
```

### See Also

[Sweep Mode - Set Dwell Time](#)

[Sweep Mode - Get Dwell Time](#)

[Sweep Mode - Get Minimum Dwell Time](#)

## 4.10 (f) - Sweep Mode - Get Minimum Dwell Time

```
int Sweep_GetMinDwell ()
```

### Description

Returns the minimum dwell time that can be used for each attenuation step within the sweep.

### Requirements

Model Name	Serial Number	Firmware
RC8DAT-8G-95	All	All
RC4DAT-8G-95	Up to 11910159999	B1 or later
	From 12001010001	All
RC4DAT-6G-95	Up to 11910299999	B1 or later
	From 11910300001	All
RC4DAT-6G-60	Up to 12007129999	B1 or later
	From 12007130001	All
RC4DAT-6G-30	Up to 12007129999	B1 or later
	From 12007239999	All
RCDAT, RUDAT & ZVVA series	All	B1 or later

### Parameters

Data Type	Variable	Description
none		

### Return Values

Data Type	Value	Description
int	MinDwell	Minimum sweep dwell time

### Examples

```

Visual Basic
    MinDwell = MyPTE1.Sweep_GetMinDwell ()

Visual C++
    MinDwell = MyPTE1->Sweep_GetMinDwell ();

Visual C#
    MinDwell = MyPTE1.Sweep_GetMinDwell ();

Matlab
    MinDwell = MyPTE1.Sweep_GetMinDwell ()
    
```

### See Also

[Sweep Mode - Set Dwell Time](#)  
[Sweep Mode - Get Dwell Time](#)  
[Sweep Mode - Get Maximum Dwell Time](#)

## 4.10 (g) - Sweep Mode - Single Channel - Set Start Attenuation

```
int Sweep_SetStartAtt(single Att)
```

### Description

Sets the first attenuation level to be loaded during the sweep for a single channel attenuator.

### Applies To

Model Name	Serial Number	Firmware
RCDAT, RUDAT & ZVVA series	All	B1 or later

### Parameters

Data Type	Variable	Description
single	Att	The initial attenuation value to be loaded during the sweep

### Return Values

Data Type	Value	Description
int	0	Command failed
	1	Command completed successfully

### Examples

#### Visual Basic

```
Status = MyPTE1.Sweep_SetStartAtt(0)
```

#### Visual C++

```
Status = MyPTE1->Sweep_SetStartAtt(0);
```

#### Visual C#

```
Status = MyPTE1.Sweep_SetStartAtt(0);
```

#### Matlab

```
Status = MyPTE1.Sweep_SetStartAtt(0)
```

### See Also

[Sweep Mode - Single Channel - Get Start Attenuation](#)

## 4.10 (h) - Sweep Mode - Single Channel - Get Start Attenuation

```
single Sweep_GetStartAtt()
```

### Description

Returns the first attenuation level to be loaded during the sweep for a single channel attenuator.

### Applies To

Model Name	Serial Number	Firmware
RCDAT, RUDAT & ZVVA series	All	B1 or later

### Parameters

Data Type	Variable	Description
none		

### Return Values

Data Type	Value	Description
single	Att	The initial attenuation to be loaded during the sweep

### Examples

```

Visual Basic
    Att = MyPTE1.Sweep_GetStartAtt()
Visual C++
    Att = MyPTE1->Sweep_GetStartAtt();
Visual C#
    Att = MyPTE1.Sweep_GetStartAtt();
Matlab
    Att = MyPTE1.Sweep_GetStartAtt()
    
```

### See Also

[Sweep Mode - Single Channel - Set Start Attenuation](#)

## 4.10 (i) - Sweep Mode - Single Channel - Set Stop Attenuation

```
int Sweep_SetStopAtt(single Att)
```

### Description

Sets the final attenuation level to be loaded during the sweep for a single channel attenuator.

### Applies To

Model Name	Serial Number	Firmware
RCDAT, RUDAT & ZVVA series	All	B1 or later

### Parameters

Data Type	Variable	Description
single	Att	The final attenuation value to be loaded during the sweep

### Return Values

Data Type	Value	Description
int	0	Command failed
	1	Command completed successfully

### Examples

```

Visual Basic
    Status = MyPTE1.Sweep_SetStopAtt(25.75)
Visual C++
    Status = MyPTE1->Sweep_SetStopAtt(25.75);
Visual C#
    Status = MyPTE1.Sweep_SetStopAtt(25.75);
Matlab
    Status = MyPTE1.Sweep_SetStopAtt(25.75)
    
```

### See Also

[Sweep Mode - Single Channel - Get Stop Attenuation](#)

## 4.10 (j) - Sweep Mode - Single Channel - Get Stop Attenuation

```
single Sweep_GetStopAtt()
```

### Description

Returns the final attenuation level to be loaded during the sweep for a single channel attenuator.

### Applies To

Model Name	Serial Number	Firmware
RCDAT, RUDAT & ZVVA series	All	B1 or later

### Parameters

Data Type	Variable	Description
none		

### Return Values

Data Type	Value	Description
single	Att	The final attenuation to be loaded during the sweep

### Examples

```

Visual Basic
    Att = MyPTE1.Sweep_GetStopAtt()
Visual C++
    Att = MyPTE1->Sweep_GetStopAtt();
Visual C#
    Att = MyPTE1.Sweep_GetStopAtt();
Matlab
    Att = MyPTE1.Sweep_GetStopAtt()
    
```

### See Also

[Sweep Mode - Single Channel - Set Stop Attenuation](#)

## 4.10 (k) - Sweep Mode - Single Channel - Set Step Size

```
int Sweep_SetStepSize(single Att)
```

### Description

Sets the attenuation step size that will be used to increment the attenuation from the start to stop levels (or decrement from stop to start if the sweep is running in the reverse direction).

### Applies To

Model Name	Serial Number	Firmware
RCDAT, RUDAT & ZVVA series	All	B1 or later

### Parameters

Data Type	Variable	Description
single	Att	The attenuation step size

### Return Values

Data Type	Value	Description
int	0	Command failed
	1	Command completed successfully

### Examples

```

Visual Basic
    Status = MyPTE1.Sweep_SetStepSize(0.75)
Visual C++
    Status = MyPTE1->Sweep_SetStepSize(0.75);
Visual C#
    Status = MyPTE1.Sweep_SetStepSize(0.75)
Matlab
    Status = MyPTE1.Sweep_SetStepSize(0.75)
    
```

### See Also

[Sweep Mode - Single Channel - Get Step Size](#)

## 4.10 (I) - Sweep Mode - Single Channel - Get Step Size

```
single Sweep_GetStepSize ()
```

### Description

Returns the attenuation step size that will be used to increment the attenuation from the start to stop levels (or decrement from stop to start if the sweep is running in the reverse direction).

### Applies To

Model Name	Serial Number	Firmware
RCDAT, RUDAT & ZVVA series	All	B1 or later

### Parameters

Data Type	Variable	Description
none		

### Return Values

Data Type	Value	Description
single	Att	The attenuation step size

### Examples

```

Visual Basic
Att = MyPTE1.Sweep_GetStepSize ()
Visual C++
Att = MyPTE1->Sweep_GetStepSize ();
Visual C#
Att = MyPTE1.Sweep_GetStepSize ();
Matlab
Att = MyPTE1.Sweep_GetStepSize ()
    
```

### See Also

[Sweep Mode - Single Channel - Set Step Size](#)

## 4.10 (m) - Sweep Mode - Multi-Channel - Set Active Channels

```
int Sweep_SetActiveChannels(int CH1_YesNo, int CH2_YesNo,
                           int CH3_YesNo, int CH4_YesNo)
```

### Description

Sets which of the 4 channels of a multi-channel attenuator are to be included in an attenuation sweep sequence.

### Applies To

RC4DAT Series

### Parameters

Data Type	Variable	Description
int	CH1_YesNo	1 to include CH1 in the sweep, 0 to leave unchanged
int	CH2_YesNo	1 to include CH2 in the sweep, 0 to leave unchanged
int	CH3_YesNo	1 to include CH3 in the sweep, 0 to leave unchanged
int	CH4_YesNo	1 to include CH4 in the sweep, 0 to leave unchanged

### Return Values

Data Type	Value	Description
int	0	Command failed
	1	Command completed successfully

### Examples

#### Visual Basic

```
Status = MyPTE1.Sweep_SetActiveChannels(1, 1, 0, 0)
' Configure a sweep for channels 1 and 2 only
```

#### Visual C++

```
Status = MyPTE1->Sweep_SetActiveChannels(1, 1, 0, 0);
// Configure a sweep for channels 1 and 2 only
```

#### Visual C#

```
Status = MyPTE1.Sweep_SetActiveChannels(1, 1, 0, 0);
// Configure a sweep for channels 1 and 2 only
```

#### Matlab

```
Status = MyPTE1.Sweep_SetActiveChannels(1, 1, 0, 0)
% Configure a sweep for channels 1 and 2 only
```

### See Also

[Sweep Mode - Multi-Channel - Get Active Channels](#)

## 4.10 (n) - Sweep Mode - Multi-Channel - Get Active Channels

```
int Sweep_GetActiveChannels (ByRef int CH1_YesNo, ByRef int CH2_YesNo,
                             ByRef int CH3_YesNo, ByRef int CH4_YesNo)
```

### Description

Checks which of the 4 channels of a multi-channel attenuator are to be included in an attenuation sweep sequence.

### Applies To

RC4DAT Series

### Parameters

Data Type	Variable	Description
int	CH1_YesNo	Reference to a variable which will be updated with the status of CH1 (1 if it included in the sweep, 0 otherwise)
int	CH2_YesNo	Reference to a variable which will be updated with the status of CH2 (1 if it included in the sweep, 0 otherwise)
int	CH3_YesNo	Reference to a variable which will be updated with the status of CH3 (1 if it included in the sweep, 0 otherwise)
int	CH4_YesNo	Reference to a variable which will be updated with the status of CH4 (1 if it included in the sweep, 0 otherwise)

### Return Values

Data Type	Value	Description
int	0	Command failed
	1	Command completed successfully

### Examples

#### Visual Basic

```
Status = MyPTE1.Sweep_GetActiveChannels(CH1, CH2, CH3, CH4)
' Check which channels are to be included in the sweep
```

#### Visual C++

```
Status = MyPTE1->Sweep_GetActiveChannels(CH1, CH2, CH3, CH4);
// Check which channels are to be included in the sweep
```

#### Visual C#

```
Status=MyPTE1.Sweep_GetActiveChannels(ref(CH1),ref(CH2),ref(CH3),ref(CH4));
// Check which channels are to be included in the sweep
```

#### Matlab

```
[Status,CH1,CH2,CH3,CH4]=MyPTE1.Sweep_GetActiveChannels(CH1, CH2, CH3, CH4)
% Check which channels are to be included in the sweep
```

### See Also

[Sweep Mode - Multi-Channel - Set Active Channels](#)

## 4.10 (o) - Sweep Mode - Multi-Channel - Set Channel Start Attenuation

```
int Sweep_SetChannelStartAtt(int Channel, float Att)
```

### Description

Sets the initial attenuation value for a single channel within a multi-channel attenuator sweep.

### Applies To

RC4DAT & RC8DAT Series

### Parameters

Data Type	Variable	Description
int	Channel	The channel number (1 to 4)
float	Att	The starting attenuation value (dB) for the above channel during a multo-channel sweep

### Return Values

Data Type	Value	Description
int	0	Command failed
	1	Command completed successfully

### Examples

#### Visual Basic

```
Status = MyPTE1.Sweep_SetChannelStartAtt(2, 15.75)
```

#### Visual C++

```
Status = MyPTE1->Sweep_SetChannelStartAtt(2, 15.75);
```

#### Visual C#

```
Status = MyPTE1.Sweep_SetChannelStartAtt(2, 15.75);
```

#### Matlab

```
Status = MyPTE1.Sweep_SetChannelStartAtt(2, 15.75)
```

### See Also

[Sweep Mode - Multi-Channel - Get Channel Start Attenuation](#)

## 4.10 (p) - Sweep Mode - Multi-Channel - Get Channel Start Attenuation

```
float Sweep_GetChannelStartAtt(int Channel)
```

### Description

Gets the initial attenuation value for a single channel within a multi-channel attenuator sweep.

### Applies To

RC4DAT & RC8DAT Series

### Parameters

Data Type	Variable	Description
int	Channel	The channel number (1 to 4)

### Return Values

Data Type	Value	Description
float	Att	The starting attenuation value (dB) for the above channel during a multo-channel sweep

### Examples

#### Visual Basic

```
Status = MyPTE1.Sweep_GetChannelStartAtt(2)
```

#### Visual C++

```
Status = MyPTE1->Sweep_GetChannelStartAtt(2);
```

#### Visual C#

```
Status = MyPTE1.Sweep_GetChannelStartAtt(2);
```

#### Matlab

```
Status = MyPTE1.Sweep_GetChannelStartAtt(2)
```

### See Also

[Sweep Mode - Multi-Channel - Set Channel Start Attenuation](#)

## 4.10 (q) - Sweep Mode - Multi-Channel - Set Channel Stop Attenuation

```
int Sweep_SetChannelStopAtt(int Channel, float Att)
```

### Description

Sets the final attenuation value for a single channel within a multi-channel attenuator sweep.

### Applies To

RC4DAT & RC8DAT Series

### Parameters

Data Type	Variable	Description
int	Channel	The channel number (1 to 4)
float	Att	The final attenuation value (dB) for the above channel during a multi-channel sweep

### Return Values

Data Type	Value	Description
int	0	Command failed
	1	Command completed successfully

### Examples

#### Visual Basic

```
Status = MyPTE1.Sweep_SetChannelStopAtt(2, 90)
```

#### Visual C++

```
Status = MyPTE1->Sweep_SetChannelStopAtt(2, 90);
```

#### Visual C#

```
Status = MyPTE1.Sweep_SetChannelStopAtt(2, 90);
```

#### Matlab

```
Status = MyPTE1.Sweep_SetChannelStopAtt(2, 90)
```

### See Also

[Sweep Mode - Multi-Channel - Set Channel Stop Attenuation](#)

## 4.10 (r) - Sweep Mode - Multi-Channel - Get Channel Stop Attenuation

```
float Sweep_GetChannelStopAtt(int Channel)
```

### Description

Gets the final attenuation value for a single channel within a multi-channel attenuator sweep.

### Applies To

RC4DAT & RC8DAT Series

### Parameters

Data Type	Variable	Description
int	Channel	The channel number (1 to 4)

### Return Values

Data Type	Value	Description
float	Att	The final attenuation value (dB) for the above channel during a multi-channel sweep

### Examples

#### Visual Basic

```
Status = MyPTE1.Sweep_GetChannelStopAtt(2)
```

#### Visual C++

```
Status = MyPTE1->Sweep_GetChannelStopAtt(2);
```

#### Visual C#

```
Status = MyPTE1.Sweep_GetChannelStopAtt(2);
```

#### Matlab

```
Status = MyPTE1.Sweep_GetChannelStopAtt(2)
```

### See Also

[Sweep Mode - Multi-Channel - Set Channel Stop Attenuation](#)

## 4.10 (s) - Sweep Mode - Multi-Channel - Set Channel Step Size

```
int Sweep_SetChannelStepSize(int Channel, float Att)
```

### Description

Sets the step size for a single channel within a multi-channel attenuator sweep.

### Applies To

RC4DAT & RC8DAT Series

### Parameters

Data Type	Variable	Description
int	Channel	The channel number (1 to 4)
float	Att	The attenuation size (dB) for the above channel during a multi-channel sweep

### Return Values

Data Type	Value	Description
int	0	Command failed
	1	Command completed successfully

### Examples

#### Visual Basic

```
Status = MyPTE1.Sweep_SetChannelStepSize(2, 0.5)
```

#### Visual C++

```
Status = MyPTE1->Sweep_SetChannelStepSize(2, 0.5);
```

#### Visual C#

```
Status = MyPTE1.Sweep_SetChannelStepSize(2, 0.5);
```

#### Matlab

```
Status = MyPTE1.Sweep_SetChannelStepSize(2, 0.5)
```

### See Also

[Sweep Mode - Multi-Channel - Get Channel Step Size](#)

## 4.10 (t) - Sweep Mode - Multi-Channel - Get Channel Step Size

```
float Sweep_GetChannelStepSize (int Channel)
```

### Description

Gets the step size for a single channel within a multi-channel attenuator sweep.

### Applies To

RC4DAT & RC8DAT Series

### Parameters

Data Type	Variable	Description
int	Channel	The channel number (1 to 4)

### Return Values

Data Type	Value	Description
float	Att	The attenuation step size (dB) for the above channel during a multo-channel sweep

### Examples

#### Visual Basic

```
Status = MyPTE1.Sweep_GetChannelStepSize (2)
```

#### Visual C++

```
Status = MyPTE1->Sweep_GetChannelStepSize (2);
```

#### Visual C#

```
Status = MyPTE1.Sweep_GetChannelStepSize (2);
```

#### Matlab

```
Status = MyPTE1.Sweep_GetChannelStepSize (2)
```

### See Also

[Sweep Mode - Multi-Channel - Set Channel Step Size](#)

## 4.10 (u) - Sweep Mode - Turn On / Off

```
int Sweep_SetMode (int On_Off)
```

### Description

Enables or disables the attenuation sweep according to the previously configured parameters.

### Notes:

- Once an attenuation sequence is programmed and enabled, it is managed by the attenuator's internal microprocessor; this supports very fast sequences with minimum dwell times in the order of 600  $\mu$ s. It is not possible to query any attenuator parameters whilst the sequence is active so any subsequent command / query to the device will disable the sequence.
- An alternative implementation method is to control the sequence and timing from your program, only sending "set attenuation" commands to the attenuator at the appropriate times. The advantage of this approach is that the program is able to query and keep track of the current attenuation state. The disadvantage is that the communication delays inherent in USB / Ethernet communication dictate a minimum dwell time in the order of milliseconds with this approach, rather than microseconds.

### Requirements

Model Name	Serial Number	Firmware
RC8DAT-8G-95	All	All
RC4DAT-8G-95	Up to 11910159999	B1 or later
	From 12001010001	All
RC4DAT-6G-95	Up to 11910299999	B1 or later
	From 11910300001	All
RC4DAT-6G-60	Up to 12007129999	B1 or later
	From 12007130001	All
RC4DAT-6G-30	Up to 12007129999	B1 or later
	From 12007239999	All
RCDAT, RUDAT & ZVVA series	All	B1 or later

### Parameters

Data Type	Variable	Description
int	On_Off	Numeric value to enable/disable the hop sequence: 0 = Disable the hop sequence 1 = Enable the hop sequence

### Return Values

Data Type	Value	Description
int	0	Command failed
	1	Command completed successfully

## Examples

**Visual Basic**

```
Status = MyPTE1.Sweep_SetMode(1)
```

**Visual C++**

```
Status = MyPTE1->Sweep_SetMode(1);
```

**Visual C#**

```
Status = MyPTE1.Sweep_SetMode(1);
```

**Matlab**

```
Status = MyPTE1.Sweep_SetMode(1)
```

## 5 - USB Control via Direct Programming (Linux)

Mini-Circuits' API DLL files require a programming environment which supports either .NET or ActiveX. Where this is not available (for example on a Linux operating system) the alternative method is “direct” USB programming using USB interrupts.

### 5.1 (a) - USB Interrupt Code Concept

To open a connection to Mini-Circuits programmable attenuators, the Vendor ID and Product ID are required:

- Mini-Circuits Vendor ID: 0x20CE
- Programmable Attenuator Product ID: 0x23

Communication with the attenuator is carried out by way of USB Interrupt. The transmitted and received buffer sizes are 64 Bytes each:

- Transmit Array = [Byte 0][Byte1][Byte2]...[Byte 63]
- Returned Array = [Byte 0][Byte1][Byte2]...[Byte 63]

In most cases, the full 64 byte buffer size is not needed so any unused bytes become “don’t care” bytes; they can take on any value without affecting the operation of the attenuator.

Worked examples can be found in the [Programming Examples & Troubleshooting Guide](#), downloadable from the Mini-Circuits website. The examples use the libhid and libusb libraries to interface with the programmable attenuator as a USB HID (Human Interface Device).

### 5.2 - Interrupts - General Commands

The commands that can be sent to the programmable attenuator are summarized in the table below and detailed on the following pages.

	Description	Command Code (Byte 0)
<b>a</b>	<a href="#">Get Device Model Name</a>	40
<b>b</b>	<a href="#">Get Device Serial Number</a>	41
<b>c</b>	<a href="#">Send SCPI Command</a>	1
<b>d</b>	<a href="#">Get Firmware</a>	99
<b>e</b>	<a href="#">Set Attenuation</a>	19
<b>f</b>	<a href="#">Read Attenuation</a>	18

## 5.2 (a) - Get Device Model Name

### Description

Returns the Mini-Circuits part number of the programmable attenuator.

### Transmit Array

Byte	Data	Description
0	40	Interrupt code for Get Device Model Name
1- 63	Not significant	"Don't care" bytes, can be any value

### Returned Array

Byte	Data	Description
0	40	Interrupt code for Get Device Model Name
1 to (n-1)	Model Name	Series of bytes containing the ASCII code for each character in the model name
n	0	Zero value byte to indicate the end of the model name
(n+1) to 63	Not significant	"Don't care" bytes, can be any value

### Example

The following array would be returned for RUDAT-6000-30 (see the [Programming Examples & Troubleshooting Guide](#) for conversions between decimal, binary and ASCII characters):

Byte	Data	Description
0	40	Interrupt code for Get Device Model Name
1	82	ASCII character code for R
2	85	ASCII character code for U
3	68	ASCII character code for D
4	68	ASCII character code for A
5	84	ASCII character code for T
6	45	ASCII character code for -
7	54	ASCII character code for 6
8	48	ASCII character code for 0
9	48	ASCII character code for 0
10	48	ASCII character code for 0
11	45	ASCII character code for -
12	51	ASCII character code for 3
13	48	ASCII character code for 0
14	0	Zero value byte to indicate end of string

### See Also

[Get Device Serial Number](#)  
 SCPI: [Get Model Name](#)

## 5.2 (b) - Get Device Serial Number

### Description

Returns the serial number of the programmable attenuator.

### Transmit Array

Byte	Data	Description
0	41	Interrupt code for Get Device Serial Number
1 - 63	Not significant	"Don't care" bytes, can be any value

### Returned Array

Byte	Data	Description
0	41	Interrupt code for Get Device Serial Number
1 to (n-1)	Serial Number	Series of bytes containing the ASCII code for each character in the serial number
n	0	Zero value byte to indicate the end of the serial number
(n+1) to 63	Not significant	"Don't care" bytes, can be any value

### Example

The following example indicates that the connected programmable attenuator has serial number 11309220111 (see the [Programming Examples & Troubleshooting Guide](#) for conversions between decimal, binary and ASCII characters):

Byte	Data	Description
0	41	Interrupt code for Get Device Serial Number
1	49	ASCII character code for 1
2	49	ASCII character code for 1
3	51	ASCII character code for 3
4	48	ASCII character code for 0
5	57	ASCII character code for 9
6	50	ASCII character code for 2
7	50	ASCII character code for 2
8	48	ASCII character code for 0
9	49	ASCII character code for 1
10	49	ASCII character code for 1
11	49	ASCII character code for 1
12	0	Zero value byte to indicate end of string

### See Also

[Get Device Model Name](#)  
 SCPI: [Get Serial Number](#)

## 5.2 (c) - Send SCPI Command

### Description

This function sends a SCPI command to the programmable attenuator and collects the returned acknowledgement. SCPI (Standard Commands for Programmable Instruments) is a common method for communicating with and controlling instrumentation products.

### Transmit Array

Byte	Data	Description
0	1	Interrupt code for Send SCPI Command
1 - 63	SCPI Transmit String	The SCPI command to send represented as a series of ASCII character codes, one character code per byte

### Returned Array

Byte	Data	Description
0	1	Interrupt code for Send SCPI Command
1 to (n-1)	SCPI Return String	The SCPI return string, one character per byte, represented as ASCII character codes
n	0	Zero value byte to indicate the end of the SCPI return string
(n+1) to 63	Not significant	"Don't care" bytes, can be any value

## Example

The SCPI command to request the model name is `:MN?` (see [Get Model Name](#))

The ASCII character codes representing the 4 characters in this command should be sent in bytes 1 to 4 of the transmit array as follows (see the [Programming Examples & Troubleshooting Guide](#) for conversions between decimal, binary and ASCII characters):

Byte	Data	Description
0	1	Interrupt code for Send SCPI Command
1	49	ASCII character code for :
2	77	ASCII character code for M
3	78	ASCII character code for N
4	63	ASCII character code for ?

The returned array for RUDAT-6000-30 would be as follows:

Byte	Data	Description
0	1	Interrupt code for Send SCPI Command
1	82	ASCII character code for R
2	85	ASCII character code for U
3	68	ASCII character code for D
4	68	ASCII character code for A
5	84	ASCII character code for T
6	45	ASCII character code for -
7	54	ASCII character code for 6
8	48	ASCII character code for 0
9	48	ASCII character code for 0
10	48	ASCII character code for 0
11	45	ASCII character code for -
12	51	ASCII character code for 3
13	48	ASCII character code for 0
14	0	Zero value byte to indicate end of string

## See Also

[Summary of SCPI Commands / Queries](#)

## 5.2 (d) - Get Firmware

### Description

This function returns the internal firmware version of the programmable attenuator.

### Transmit Array

Byte	Data	Description
0	99	Interrupt code for Get Firmware
1 - 63	Not significant	“Don’t care” bytes, can be any value

### Returned Array

Byte	Data	Description
0	99	Interrupt code for Get Firmware
1	Reserved	Internal code for factory use only
2	Reserved	Internal code for factory use only
3	Reserved	Internal code for factory use only
4	Reserved	Internal code for factory use only
5	Firmware Letter	ASCII code for the first character in the firmware revision identifier
6	Firmware Number	ASCII code for the second character in the firmware revision identifier
7 - 63	Not significant	“Don’t care” bytes, could be any value

### Example

The below returned array indicates that the system has firmware version “C3” (see the [Programming Examples & Troubleshooting Guide](#) for conversions between decimal, binary and ASCII characters):

Byte	Data	Description
0	99	Interrupt code for Get Firmware
1	49	Not significant
2	77	Not significant
3	78	Not significant
4	63	Not significant
5	67	ASCII character code for C
6	51	ASCII character code for 3

### See Also

SCPI: [Get Firmware](#)

## 5.2 (e) - Set Attenuation

### Description

This function sets the RF attenuation level. The allowed attenuation range and precision is defined in the individual model datasheets.

### Transmit Array

Byte	Data	Description
0	19	Interrupt code for Set Attenuation
1	Att_Byte0	First byte of the attenuation (dB) to set: $\text{Att\_Byte0} = \text{INTEGER}(\text{Attenuation})$
2	Att_Byte1	Second byte of the attenuation (dB) to set: $\text{Att\_Byte1} = (\text{Attenuation} - \text{Att\_Byte0}) * 4$
3	Channel_No	The attenuator channel to set (for single channel models the channel number is 1)
4 - 63	Not significant	"Don't care" bytes, can be any value

### Returned Array

Byte	Data	Description
0	19	Interrupt code for Set Attenuation
1 - 63	Not significant	"Don't care" bytes, could be any value

### Example

To set RUDAT-6000-90 to 43.75 dB, the transmit array is:

Byte	Data	Description
0	19	Interrupt code for Set Attenuation
1	43	$\text{Att\_Byte0} = \text{INTEGER}(43.75)$ $= 43$
2	3	$\text{Att\_Byte1} = (43.75 - 43) * 4$ $= 3$
3	1	Channel 1 for single channel models

### See Also

[Read Attenuation](#)

## 5.2 (f) - Read Attenuation

### Description

This function returns the current attenuation setting.

### Transmit Array

Byte	Data	Description
0	18	Interrupt code for Read Attenuation
1 - 63	Not significant	"Don't care" bytes, can be any value

### Returned Array

Byte	Data	Description
0	18	Interrupt code for Read Attenuation
1	CH1_Att_Byte0	First byte of the attenuation (dB) for channel 1 (note: single channel models only have channel 1)
2	CH1_Att_Byte1	Second byte of the attenuation (dB) for channel 1 (note: single channel models only have channel 1) Attenuation = CH1_Att_Byte0 + (CH1_Att_Byte1 / 4)
3	CH2_Att_Byte0	First byte of the attenuation (dB) for channel 2 (note: not relevant to single channel models)
4	CH2_Att_Byte1	Second byte of the attenuation (dB) for channel 2 (note: not relevant to single channel models) Attenuation = CH2_Att_Byte0 + (CH2_Att_Byte1 / 4)
5	CH3_Att_Byte0	First byte of the attenuation (dB) for channel 3 (note: not relevant to single channel models)
6	CH3_Att_Byte1	Second byte of the attenuation (dB) for channel 3 (note: not relevant to single channel models) Attenuation = CH3_Att_Byte0 + (CH3_Att_Byte1 / 4)
7	CH4_Att_Byte0	First byte of the attenuation (dB) for channel 4 (note: not relevant to single channel models)
8	CH4_Att_Byte1	Second byte of the attenuation (dB) for channel 4 (note: not relevant to single channel models) Attenuation = CH4_Att_Byte0 + (CH4_Att_Byte1 / 4)
9 - 63	Not significant	"Don't care" bytes, could be any value

## Examples

The following return array would indicate an attenuation of 75.75 dB for RCDAT-6000-90 (single channel model):

Byte	Data	Description
0	18	Interrupt code for Read Attenuation
1	75	
2	3	Attenuation = $75 + (3 / 4)$ = 75.75 dB

The following return array would indicate an attenuations of 75.75dB, 50.25 dB, 0 dB and 5 dB respectively for channels 1 to 4 of RC4DAT & RC8DAT Series (4 channel model):

Byte	Data	Description
0	18	Interrupt code for Read Attenuation
1	75	
2	3	CH1 Attenuation = $75 + (3 / 4)$ = 75.75 dB
3	50	
4	1	CH2 Attenuation = $50 + (1 / 4)$ = 50.25 dB
5	0	
6	0	CH3 Attenuation = $0 + (0 / 4)$ = 0 dB
7	5	
8	0	CH4 Attenuation = $5 + (0 / 4)$ = 5 dB

## See Also

[Set Attenuation](#)

### 5.3 - Interrupts - Ethernet Configuration Commands

These commands and queries apply to Mini-Circuits' RC series of programmable attenuators for configuring the Ethernet parameters.

	Description	Command Code	
		Byte 0	Byte 1
<b>a</b>	Set Static IP Address	250	201
<b>b</b>	Set Static Subnet Mask	250	202
<b>c</b>	Set Static Network Gateway	250	203
<b>d</b>	Set HTTP Port	250	204
<b>e</b>	Set Telnet Port	250	214
<b>f</b>	Enable Custom Telnet Prompt	250	210
<b>g</b>	Set Custom Telnet Prompt Text	250	211
<b>h</b>	Use Password	250	205
<b>i</b>	Set Password	250	206
<b>j</b>	Use DHCP	250	207
<b>k</b>	Get Static IP Address	251	201
<b>l</b>	Get Static Subnet Mask	251	202
<b>m</b>	Get Static Network Gateway	251	203
<b>n</b>	Get HTTP Port	251	204
<b>o</b>	Get Telnet Port	251	214
<b>p</b>	Query Telnet Prompt Type	251	210
<b>q</b>	Get Custom Telnet Prompt Text	251	211
<b>r</b>	Get Password Status	251	205
<b>s</b>	Get Password	251	206
<b>t</b>	Get DHCP Status	251	207
<b>u</b>	Get Dynamic Ethernet Configuration	253	
<b>v</b>	Get MAC Address	252	
<b>w</b>	Reset Ethernet Configuration	101	101

### 5.3 (a) - Set Static IP Address

#### Description

Sets the static IP address to be used when DHCP (dynamic host control protocol) is disabled.

#### Transmit Array

Byte	Data	Description
0	250	Interrupt code for Set Ethernet Configuration
1	201	Interrupt code for Set IP Address
2	IP_Byte0	First byte of IP address
3	IP_Byte1	Second byte of IP address
4	IP_Byte2	Third byte of IP address
5	IP_Byte3	Fourth byte of IP address
6 - 63	Not significant	Any value

#### Returned Array

Byte	Data	Description
0	250	Interrupt code for Set Ethernet Configuration
1 - 63	Not significant	Any value

#### Example

To set the static IP address to 192.168.100.100, the transmit array is:

Byte	Data	Description
0	250	Interrupt code for Set Ethernet Configuration
1	201	Interrupt code for Set IP Address
2	192	First byte of IP address
3	168	Second byte of IP address
4	100	Third byte of IP address
5	100	Fourth byte of IP address

#### See Also

- [Use DHCP](#)
- [Get Static IP Address](#)
- [Reset Ethernet Configuration](#)

### 5.3 (b) - Set Static Subnet Mask

#### Description

Sets the static subnet mask to be used when DHCP (dynamic host control protocol) is disabled.

#### Transmit Array

Byte	Data	Description
0	250	Interrupt code for Set Ethernet Configuration
1	202	Interrupt code for Set Subnet Mask
2	IP_Byte0	First byte of subnet mask
3	IP_Byte1	Second byte of subnet mask
4	IP_Byte2	Third byte of subnet mask
5	IP_Byte3	Fourth byte of subnet mask
6 - 63	Not significant	Any value

#### Returned Array

Byte	Data	Description
0	250	Interrupt code for Set Ethernet Configuration
1 - 63	Not significant	Any value

#### Example

To set the static subnet mask to 255.255.255.0, the transmit array is:

Byte	Data	Description
0	250	Interrupt code for Set Ethernet Configuration
1	202	Interrupt code for Set Subnet Mask
2	255	First byte of subnet mask
3	255	Second byte of subnet mask
4	255	Third byte of subnet mask
5	0	Fourth byte of subnet mask

#### See Also

- [Use DHCP](#)
- [Get Static Subnet Mask](#)
- [Reset Ethernet Configuration](#)

### 5.3 (c) - Set Static Network Gateway

#### Description

Sets the network gateway IP address to be used when DHCP (dynamic host control protocol) is disabled.

#### Transmit Array

Byte	Data	Description
0	250	Interrupt code for Set Ethernet Configuration
1	203	Interrupt code for Set Network Gateway
2	IP_Byte0	First byte of network gateway IP address
3	IP_Byte1	Second byte of network gateway IP address
4	IP_Byte2	Third byte of network gateway IP address
5	IP_Byte3	Fourth byte of network gateway IP address
6 - 63	Not significant	Any value

#### Returned Array

Byte	Data	Description
0	250	Interrupt code for Set Ethernet Configuration
1 - 63	Not significant	Any value

#### Example

To set the static IP address to 192.168.100.0, the transmit array is:

Byte	Data	Description
0	250	Interrupt code for Set Ethernet Configuration
1	203	Interrupt code for Set Network Gateway
2	192	First byte of IP address
3	168	Second byte of IP address
4	100	Third byte of IP address
5	0	Fourth byte of IP address

#### See Also

[Use DHCP](#)  
[Get Static Network Gateway](#)  
[Reset Ethernet Configuration](#)

### 5.3 (d) - Set HTTP Port

#### Description

Sets the port to be used for HTTP communication (default is port 80).

#### Transmit Array

Byte	Data	Description
0	250	Interrupt code for Set Ethernet Configuration
1	204	Interrupt code for Set HTTP Port
2	Port_Byte0	First byte (MSB) of HTTP port value: Port_Byte0 = INTEGER (Port / 256)
3	Port_Byte1	Second byte (LSB) of HTTP port value: Port_byte1 = Port - (Port_Byte0 * 256)
4 - 63	Not significant	Any value

#### Returned Array

Byte	Data	Description
0	250	Interrupt code for Set Ethernet Configuration
1 - 63	Not significant	Any value

#### Example

To set the HTTP port to 8080, the transmit array is:

Byte	Data	Description
0	250	Interrupt code for Set Ethernet Configuration
1	204	Interrupt code for Set HTTP Port
2	31	Port_Byte0 = INTEGER (8080 / 256)
3	144	Port_byte1 = 8080 - (31 * 256)

#### See Also

- [Set Telnet Port](#)
- [Get HTTP Port](#)
- [Get Telnet Port](#)
- [Reset Ethernet Configuration](#)

### 5.3 (e) - Set Telnet Port

#### Description

Sets the port to be used for Telnet communication (default is port 23).

#### Transmit Array

Byte	Data	Description
0	250	Interrupt code for Set Ethernet Configuration
1	214	Interrupt code for Set Telnet Port
2	Port_Byte0	First byte (MSB) of Telnet port value: Port_Byte0 = INTEGER (Port / 256)
3	Port_Byte1	Second byte (LSB) of Telnet port value: Port_byte1 = Port - (Port_Byte0 * 256)
4 - 63	Not significant	Any value

#### Returned Array

Byte	Data	Description
0	250	Interrupt code for Set Ethernet Configuration
1 - 63	Not significant	Any value

#### Example

To set the Telnet port to 22, the transmit array is:

Byte	Data	Description
0	250	Interrupt code for Set Ethernet Configuration
1	214	Interrupt code for Set Telnet Port
2	0	Port_Byte0 = INTEGER (22 / 256)
3	22	Port_byte1 = 22 - (0 * 256)

#### See Also

- [Set HTTP Port](#)
- [Get HTTP Port](#)
- [Get Telnet Port](#)
- [Reset Ethernet Configuration](#)

### 5.3 (f) - Enable Custom Telnet Prompt

When enabled, a custom text string will be returned as a prompt when the attenuator is ready to receive the next Telnet command. The custom prompt is disabled by default so only a new line character is returned.

#### Applies To

Model Name	Serial Number	Firmware
RC8DAT-8G-95	All	All
RC4DAT-8G-95	Up to 11910159999	D5 or later
	From 12001010001	All
RC4DAT-6G-95	Up to 11910299999	D5 or later
	From 11910300001	All
RC4DAT-6G-60	Up to 12007129999	D5 or later
	From 12007130001	All
RC4DAT-6G-30	Up to 12007129999	D5 or later
	From 12007239999	All
RCDAT series	All	D5 or later

#### Transmit Array

Byte	Data	Description
0	250	Interrupt code for Set Ethernet Configuration
1	210	Interrupt code for Enable Custom Telnet Prompt
2	Mode	0 = Custom Telnet prompt disabled (new line character will be returned) 1 = Custom Telnet prompt enabled (see <a href="#">Set Custom Telnet Prompt Text</a> to set the text)
3 - 63	Not significant	Any value

#### Returned Array

Byte	Data	Description
0	250	Interrupt code for Set Ethernet Configuration
1 - 63	Not significant	Any value

#### Example

To enable a custom Telnet prompt, the transmit array is:

Byte	Data	Description
0	250	Interrupt code for Set Ethernet Configuration
1	210	Interrupt code for Enable Custom Telnet Prompt
2	1	Enable custom Telnet prompt

#### See Also

[Set Custom Telnet Prompt Text](#)  
[Query Telnet Prompt Type](#)  
[Get Custom Telnet Prompt Text](#)

### 5.3 (g) - Set Custom Telnet Prompt Text

Sets the text string (up to 10 characters) which will be used as a Telnet prompt when the custom prompt is enabled.

#### Applies To

Model Name	Serial Number	Firmware
RC8DAT-8G-95	All	All
RC4DAT-8G-95	Up to 11910159999	D5 or later
	From 12001010001	All
RC4DAT-6G-95	Up to 11910299999	D5 or later
	From 11910300001	All
RC4DAT-6G-60	Up to 12007129999	D5 or later
	From 12007130001	All
RC4DAT-6G-30	Up to 12007129999	D5 or later
	From 12007239999	All
RCDAT series	All	D5 or later

#### Transmit Array

Byte	Data	Description
0	250	Interrupt code for Set Ethernet Configuration
1	211	Interrupt code for Set Custom Telnet Prompt Text
2-63	String	The text string to set as the Telnet prompt, represented as a series of ASCII character codes, one character code per byte. The final byte should be zero value to indicate the end of the string. Special cases can also be used: <a href="#">MN</a> - The device's model name will be used <a href="#">SN</a> - The device's serial number will be used

#### Returned Array

Byte	Data	Description
0	250	Interrupt code for Set Ethernet Configuration
1 - 63	Not significant	Any value

#### Example

To enable a custom Telnet prompt of "RCDAT", the transmit array is:

Byte	Data	Description
0	250	Interrupt code for Set Ethernet Configuration
1	211	Interrupt code for Set Custom Telnet Prompt Text
2	82	ASCII character code for R
3	67	ASCII character code for C
4	68	ASCII character code for D
5	68	ASCII character code for A
6	84	ASCII character code for T
7	0	Zero value byte to indicate the end of the string
14	0	Zero value byte to indicate end of string

#### See Also

- [Enable Custom Telnet Prompt](#)
- [Query Telnet Prompt Type](#)
- [Get Custom Telnet Prompt Text](#)

## 5.3 (h) - Use Password

### Description

Enables or disables the requirement to password protect the HTTP / Telnet communication.

### Transmit Array

Byte	Data	Description
0	250	Interrupt code for Set Ethernet Configuration
1	205	Interrupt code for Use Password
2	PW_Mode	0 = password not required (default) 1 = password required
3 - 63	Not significant	Any value

### Returned Array

Byte	Data	Description
0	250	Interrupt code for Set Ethernet Configuration
1 - 63	Not significant	Any value

### Example

To enable the password requirement for Ethernet communication, the transmit array is:

Byte	Data	Description
0	250	Interrupt code for Set Ethernet Configuration
1	205	Interrupt code for Use Password
2	1	Enable password requirement

### See Also

- [Set Password](#)
- [Get Password Status](#)
- [Get Password](#)
- [Reset Ethernet Configuration](#)

### 5.3 (i) - Set Password

#### Description

Sets the password to be used for Ethernet communication (when password security is enabled, maximum 20 characters).

#### Transmit Array

Byte	Data	Description
0	250	Interrupt code for Set Ethernet Configuration
1	206	Interrupt code for Set Password
2	PW_Length	Length (number of characters) of the password
3 to n	PW_Char	Series of ASCII character codes (1 per byte) for the Ethernet password
n + 1 to 63	Not significant	Any value

#### Returned Array

Byte	Data	Description
0	250	Interrupt code for Set Ethernet Configuration
1 to 63	Not significant	Any value

#### Example

To set the password to *Pass\_123*, the transmit array is:

Byte	Data	Description
0	250	Interrupt code for Set Ethernet Configuration
1	206	Interrupt code for Set Password
2	8	Length of password (8 characters)
3	80	ASCII character code for P
4	97	ASCII character code for a
5	115	ASCII character code for s
6	115	ASCII character code for s
7	95	ASCII character code for _
8	49	ASCII character code for 1
9	50	ASCII character code for 2
10	51	ASCII character code for 3

#### See Also

- [Use Password](#)
- [Get Password Status](#)
- [Get Password](#)
- [Reset Ethernet Configuration](#)

## 5.3 (j) - Use DHCP

### Description

Enables or disables DHCP (dynamic host control protocol). With DHCP enabled, the attenuators Ethernet / IP configuration is assigned by the network and any user defined static IP settings are ignored. With DHCP disabled, the user defined static IP settings are used.

### Transmit Array

Byte	Data	Description
0	250	Interrupt code for Set Ethernet Configuration
1	207	Interrupt code for Use DHCP
2	DHCP_Mode	0 = DCHP disabled (static IP settings in use) 1 = DHCP enabled (default - dynamic IP in use)
3 - 63	Not significant	Any value

### Returned Array

Byte	Data	Description
0	250	Interrupt code for Set Ethernet Configuration
1 - 63	Not significant	Any value

### Example

To enable DHCP for Ethernet communication, the transmit array is:

Byte	Data	Description
0	250	Interrupt code for Set Ethernet Configuration
1	207	Interrupt code for Use DHCP
2	1	Enable DHCP

### See Also

[Use DHCP](#)  
[Get DHCP Status](#)  
[Get Dynamic Ethernet Configuration](#)  
[Reset Ethernet Configuration](#)

### 5.3 (k) - Get Static IP Address

#### Description

Gets the static IP address (configured by the user) to be used when DHCP (dynamic host control protocol) is disabled.

#### Transmit Array

Byte	Data	Description
0	251	Interrupt code for Get Ethernet Configuration
1	201	Interrupt code for Get IP Address
2 - 63	Not significant	Any value

#### Returned Array

Byte	Data	Description
0	251	Interrupt code for Get Ethernet Configuration
1	IP_Byte0	First byte of IP address
2	IP_Byte1	Second byte of IP address
3	IP_Byte2	Third byte of IP address
4	IP_Byte3	Fourth byte of IP address
5 - 63	Not significant	Any value

#### Example

The following returned array would indicate that a static IP address of 192.168.100.100 has been configured:

Byte	Data	Description
0	251	Interrupt code for Get Ethernet Configuration
1	192	First byte of IP address
2	168	Second byte of IP address
3	100	Third byte of IP address
4	100	Fourth byte of IP address

#### See Also

[Use DHCP](#)  
[Set Static IP Address](#)

## 5.3 (I) - Get Static Subnet Mask

### Description

Gets the subnet mask (configured by the user) to be used when DHCP (dynamic host control protocol) is disabled.

### Transmit Array

Byte	Data	Description
0	251	Interrupt code for Get Ethernet Configuration
1	202	Interrupt code for Get Subnet Mask
2 - 63	Not significant	Any value

### Returned Array

Byte	Data	Description
0	251	Interrupt code for Get Ethernet Configuration
1	IP_Byte0	First byte of subnet mask
2	IP_Byte1	Second byte of subnet mask
3	IP_Byte2	Third byte of subnet mask
4	IP_Byte3	Fourth byte of subnet mask
5 - 63	Not significant	Any value

### Example

The following returned array would indicate that a subnet mask of 255.255.255.0 has been configured:

Byte	Data	Description
0	251	Interrupt code for Get Ethernet Configuration
1	255	First byte of subnet mask
2	255	Second byte of subnet mask
3	255	Third byte of subnet mask
4	0	Fourth byte of subnet mask

### See Also

[Use DHCP](#)  
[Set Static Subnet Mask](#)

### 5.3 (m) - Get Static Network Gateway

#### Description

Gets the static IP address (configured by the user) of the network gateway to be used when DHCP (dynamic host control protocol) is disabled.

#### Transmit Array

Byte	Data	Description
0	251	Interrupt code for Get Ethernet Configuration
1	203	Interrupt code for Get Network Gateway
2 - 63	Not significant	Any value

#### Returned Array

Byte	Data	Description
0	251	Interrupt code for Get Ethernet Configuration
1	IP_Byte0	First byte of IP address
2	IP_Byte1	Second byte of IP address
3	IP_Byte2	Third byte of IP address
4	IP_Byte3	Fourth byte of IP address
5 - 63	Not significant	Any value

#### Example

The following returned array would indicate that a network gateway IP address of 192.168.100.0 has been configured:

Byte	Data	Description
0	251	Interrupt code for Get Ethernet Configuration
1	192	First byte of IP address
2	168	Second byte of IP address
3	100	Third byte of IP address
4	0	Fourth byte of IP address

#### See Also

[Use DHCP](#)  
[Set Static Network Gateway](#)

### 5.3 (n) - Get HTTP Port

#### Description

Gets the port to be used for HTTP communication (default is port 80).

#### Transmit Array

Byte	Data	Description
0	251	Interrupt code for Get Ethernet Configuration
1	204	Interrupt code for Get HTTP Port
2 - 63	Not significant	Any value

#### Returned Array

Byte	Data	Description
0	251	Interrupt code for Get Ethernet Configuration
1	Port_Byte0	First byte (MSB) of HTTP port value:
2	Port_Byte1	Second byte (LSB) of HTTP port value: Port = (Port_Byte0 * 256) + Port_Byte1
3 - 63	Not significant	Any value

#### Example

The following returned array would indicate that the HTTP port has been configured as 8080:

Byte	Data	Description
0	251	Interrupt code for Get Ethernet Configuration
1	31	
2	144	Port = (31 * 256) + 144 = 8080

#### See Also

[Set HTTP Port](#)  
[Set Telnet Port](#)  
[Get Telnet Port](#)

### 5.3 (o) - Get Telnet Port

#### Description

Gets the port to be used for Telnet communication (default is port 23).

#### Transmit Array

Byte	Data	Description
0	251	Interrupt code for Get Ethernet Configuration
1	214	Interrupt code for Get Telnet Port
2 - 63	Not significant	Any value

#### Returned Array

Byte	Data	Description
0	251	Interrupt code for Get Ethernet Configuration
1	Port_Byte0	First byte (MSB) of Telnet port value:
2	Port_Byte1	Second byte (LSB) of Telnet port value: Port = (Port_Byte0 * 256) + Port_Byte1
3 - 63	Not significant	Any value

#### Example

The following returned array would indicate that the Telnet port has been configured as 22:

Byte	Data	Description
0	251	Interrupt code for Get Ethernet Configuration
1	0	
2	22	Port = (0 * 256) + 22 = 22

#### See Also

[Set HTTP Port](#)  
[Set Telnet Port](#)  
[Get HTTP Port](#)

### 5.3 (p) - Query Telnet Prompt Type

Indicates whether the custom Telnet prompt is enabled. When enabled, a custom text string will be returned as a prompt when the attenuator is ready to receive the next Telnet command. The custom prompt is disabled by default so only a new line character is returned.

#### Requirements

Model Name	Serial Number	Firmware
RC8DAT-8G-95	All	All
RC4DAT-8G-95	Up to 11910159999	D5 or later
	From 12001010001	All
RC4DAT-6G-95	Up to 11910299999	D5 or later
	From 11910300001	All
RC4DAT-6G-60	Up to 12007129999	D5 or later
	From 12007130001	All
RC4DAT-6G-30	Up to 12007129999	D5 or later
	From 12007239999	All
RCDAT series	All	D5 or later

#### Transmit Array

Byte	Data	Description
0	251	Interrupt code for Get Ethernet Configuration
1	210	Interrupt code for Query Telnet Prompt Type
2 - 63	Not significant	Any value

#### Returned Array

Byte	Data	Description
0	251	Interrupt code for Get Ethernet Configuration
1	Mode	0 = Custom Telnet prompt disabled (new line character will be returned) 1 = Custom Telnet prompt enabled (see <a href="#">Set Custom Telnet Prompt Text</a> to set the text)
2 - 63	Not significant	Any value

#### Example

The following returned array would indicate that a custom Telnet prompt has been enabled:

Byte	Data	Description
0	251	Interrupt code for Get Ethernet Configuration
1	1	Custom Telnet prompt enabled

#### See Also

[Enable Custom Telnet Prompt](#)  
[Set Custom Telnet Prompt Text](#)  
[Get Custom Telnet Prompt Text](#)

### 5.3 (q) - Get Custom Telnet Prompt Text

Returns the text string (up to 10 characters) which will be used as a Telnet prompt when the custom prompt is enabled.

#### Requirements

Model Name	Serial Number	Firmware
RC8DAT-8G-95	All	All
RC4DAT-8G-95	Up to 11910159999	D5 or later
	From 12001010001	All
RC4DAT-6G-95	Up to 11910299999	D5 or later
	From 11910300001	All
RC4DAT-6G-60	Up to 12007129999	D5 or later
	From 12007130001	All
RC4DAT-6G-30	Up to 12007129999	D5 or later
	From 12007239999	All
RCDAT series	All	D5 or later

#### Transmit Array

Byte	Data	Description
0	251	Interrupt code for Get Ethernet Configuration
1	211	Interrupt code for Get Custom Telnet Prompt Text
2 - 63	Not significant	Any value

#### Returned Array

Byte	Data	Description
0	251	Interrupt code for Get Ethernet Configuration
1-63	String	The text string that will be used as the Telnet prompt, represented as a series of ASCII character codes, one character code per byte. The final byte will be zero value to indicate the end of the string. Special cases also exist: <a href="#">MN</a> - The device's model name will be used <a href="#">SN</a> - The device's serial number will be used

#### Example

The following returned array would indicate that the custom Telnet prompt text is "RCDAT":

Byte	Data	Description
0	251	Interrupt code for Get Ethernet Configuration
1	82	ASCII character code for R
2	67	ASCII character code for C
3	68	ASCII character code for D
4	68	ASCII character code for A
5	84	ASCII character code for T
6	0	Zero value byte to indicate the end of the string

#### See Also

- [Enable Custom Telnet Prompt](#)
- [Set Custom Telnet Prompt Text](#)
- [Query Telnet Prompt Type](#)

### 5.3 (r) - Get Password Status

#### Description

Checks whether the attenuators has been configured to require a password for HTTP / Telnet communication.

#### Transmit Array

Byte	Data	Description
0	251	Interrupt code for Get Ethernet Configuration
1	205	Interrupt code for Get Password Status
2 - 63	Not significant	Any value

#### Returned Array

Byte	Data	Description
0	251	Interrupt code for Set Ethernet Configuration
1	PW_Mode	0 = password not required (default) 1 = password required
2 - 63	Not significant	Any value

#### Example

The following returned array indicates that password protection is enabled:

Byte	Data	Description
0	251	Interrupt code for Get Ethernet Configuration
1	1	Password protection enabled

#### See Also

[Use Password](#)  
[Set Password](#)  
[Get Password](#)

### 5.3 (s) - Get Password

#### Description

Gets the password to be used for Ethernet communication (when password security is enabled, maximum 20 characters).

#### Transmit Array

Byte	Data	Description
0	251	Interrupt code for Get Ethernet Configuration
1	206	Interrupt code for Get Password
2 to 63	Not significant	Any value

#### Returned Array

Byte	Data	Description
0	251	Interrupt code for Get Ethernet Configuration
1	PW_Length	Length (number of characters) of the password
2 to n	PW_Char	Series of ASCII character codes (1 per byte) for the Ethernet password
n to 63	Not significant	Any value

#### Example

The following returned array indicated that the password has been set to *Pass\_123*:

Byte	Data	Description
0	251	Interrupt code for Get Ethernet Configuration
1	8	Length of password (8 characters)
2	80	ASCII character code for P
3	97	ASCII character code for a
4	115	ASCII character code for s
5	115	ASCII character code for s
6	95	ASCII character code for _
7	49	ASCII character code for 1
8	50	ASCII character code for 2
9	51	ASCII character code for 3

#### See Also

[Use Password](#)  
[Set Password](#)  
[Get Password Status](#)

### 5.3 (t) - Get DHCP Status

#### Description

Checks whether DHCP (dynamic host control protocol) is enabled or disabled. With DHCP enabled, the attenuators Ethernet / IP configuration is assigned by the network and any user defined static IP settings are ignored. With DHCP disabled, the user defined static IP settings are used.

#### Transmit Array

Byte	Data	Description
0	251	Interrupt code for Get Ethernet Configuration
1	207	Interrupt code for Get DHCP Status
2 - 63	Not significant	Any value

#### Returned Array

Byte	Data	Description
0	251	Interrupt code for Set Ethernet Configuration
1	DCHP_Mode	0 = DCHP disabled (static IP settings in use) 1 = DHCP enabled (default - dynamic IP in use)
2 - 63	Not significant	Any value

#### Example

The following returned array indicates that DHCP is enabled:

Byte	Data	Description
0	251	Interrupt code for Get Ethernet Configuration
1	1	DHCP enabled

#### See Also

[Use DHCP](#)  
[Get Dynamic Ethernet Configuration](#)

### 5.3 (u) - Get Dynamic Ethernet Configuration

#### Description

Returns the IP address, subnet mask and default gateway currently used by the programmable attenuator. If DHCP is enabled then these values are assigned by the network DHCP server. If DHCP is disabled then these values are the static configuration defined by the user.

#### Transmit Array

Byte	Data	Description
0	253	Interrupt code for Get Dynamic Ethernet Configuration
1 - 63	Not significant	Any value

#### Returned Array

Byte	Data	Description
0	253	Interrupt code for Get Dynamic Ethernet Configuration
1	IP_Byte0	First byte of IP address
2	IP_Byte1	Second byte of IP address
3	IP_Byte2	Third byte of IP address
4	IP_Byte3	Fourth byte of IP address
5	SM_Byte0	First byte of subnet mask
6	SM_Byte1	Second byte of subnet mask
7	SM_Byte2	Third byte of subnet mask
8	SM_Byte3	Fourth byte of subnet mask
9	NG_Byte0	First byte of network gateway IP address
10	NG_Byte1	Second byte of network gateway IP address
11	NG_Byte2	Third byte of network gateway IP address
12	NG_Byte3	Fourth byte of network gateway IP address
13 - 63	Not significant	Any value

## Example

The following returned array would indicate the below Ethernet configuration is active:

- IP Address: 192.168.100.100
- Subnet Mask: 255.255.255.0
- Network Gateway: 192.168.100.0

Byte	Data	Description
0	253	Interrupt code for Get Dynamic Ethernet Configuration
1	192	First byte of IP address
2	168	Second byte of IP address
3	100	Third byte of IP address
4	100	Fourth byte of IP address
5	255	First byte of subnet mask
6	255	Second byte of subnet mask
7	255	Third byte of subnet mask
8	0	Fourth byte of subnet mask
9	192	First byte of network gateway IP address
10	168	Second byte of network gateway IP address
11	100	Third byte of network gateway IP address
12	0	Fourth byte of network gateway IP address

## See Also

[Use DHCP](#)

[Get DHCP Status](#)

### 5.3 (v) - Get MAC Address

#### Description

Returns the MAC address of the programmable attenuator.

#### Transmit Array

Byte	Data	Description
0	252	Interrupt code for Get MAC Address
1 - 63	Not significant	Any value

#### Returned Array

Byte	Data	Description
0	252	Interrupt code for Get MAC Address
1	MAC_Byte0	First byte of MAC address
2	MAC_Byte1	Second byte of MAC address
3	MAC_Byte2	Third byte of MAC address
4	MAC_Byte3	Fourth byte of MAC address
5	MAC_Byte4	Fifth byte of MAC address
6	MAC_Byte5	Sixth byte of MAC address
7 - 63	Not significant	Any value

#### Example

The following returned array would indicate a MAC address (in decimal notation) of 11:47:165:103:137:171:

Byte	Data	Description
0	252	Interrupt code for Get MAC Address
1	11	First byte of MAC address
2	47	Second byte of MAC address
3	165	Third byte of MAC address
4	103	Fourth byte of MAC address
5	137	Fifth byte of MAC address
6	171	Sixth byte of MAC address

#### See Also

[Get Dynamic Ethernet Configuration](#)

### 5.3 (w) - Reset Ethernet Configuration

#### Description

Forces the programmable attenuator to reset and adopt the latest Ethernet configuration. Must be sent after any changes are made to the configuration.

#### Transmit Array

Byte	Data	Description
0	101	Reset Ethernet configuration sequence
1	101	Reset Ethernet configuration sequence
2	102	Reset Ethernet configuration sequence
3	103	Reset Ethernet configuration sequence
4 - 63	Not significant	Any value

#### Returned Array

Byte	Data	Description
0	101	Confirmation of reset Ethernet configuration sequence
1 - 63	Not significant	Any value

## 6 - Serial Control Using RS232 Communication

Mini-Circuits' ZVVA and RUDAT programmable attenuator series have a 9-pin D-Sub connector for serial RS232 communication. To create a connection to the programmable attenuator, the following settings should be used:

- Baud = 9600
- Parity = N
- Data\_Bits = 8

The 9-pin D-Sub connector of the attenuator should be connected to the computer's RS232 port. DC power can be supplied either through the USB port or pin 1 of the D-Sub connector (model dependent, see user manual for confirmation).

Communication with the attenuator is based on sending and receiving ASCII data over the RS232 port. Each command must be followed by a Carriage Return character.

### 6.1 - Summary of ASCII Commands

The commands that can be sent to the programmable attenuator are summarized in the table below and detailed on the following pages.

	Description	Command	Comments
<b>a</b>	Get Device Model Name	M\r	
<b>b</b>	Get Device Serial Number	S\r	
<b>c</b>	Set Attenuation	B[a]E\r	a = attenuation
<b>d</b>	Read Attenuation (Integer)	R\r	
<b>e</b>	Read Attenuation (Decimal)	A\r	
<b>f</b>	Send SCPI Command	P[c]\r	c = SCPI command

## 6.2 - Description of ASCII Commands

### 6.2 (a) - Get Device Model Name

This function determines the Mini-Circuits model name of the connected attenuator.

#### Command

**M**

#### Return Value

[mn]

Where:

[mn] = model name of the attenuator

#### Example

Send the text command "M\r".

The response will be of the format "RUDAT-6000-30".

#### See Also

[Get Device Serial Number](#)

## 6.2 (b) - Get Device Serial Number

This function returns the serial number of the connected attenuator.

### Command

**S**

### Return Value

[sn]

Where:

[sn] = serial number of the attenuator

### Example

Send the text command "S\r".

The response will be of the format "11301050025".

### See Also

[Get Device Model Name](#)

## 6.2 (c) - Set Attenuation

This function sets the RF attenuation level. The allowed attenuation range and precision is defined in the individual model datasheets.

### Command

**B [a] E**

Where:

[a] = attenuation value to set

### Return Value

**ACK**

### Example

To set the RF attenuation to 20.25dB:

- [a] = 20.25

Send the text command "B20.25E\r".

### See Also

[Read Attenuation \(Integer\)](#)

[Read Attenuation \(Decimal\)](#)

## 6.2 (d) - Read Attenuation (Integer)

Returns the current RF attenuation value in terms of the number of attenuation steps set. To calculate the decimal attenuation value:

$$\text{Attenuation} = \text{Returned Value} \times \text{Minimum Step Size}$$

### Command

**R**

### Return Value

[a]

Where:

[a] = attenuation divided by minimum step size

### Example

Send the text command "R\r".

A response of "82" indicates the following attenuation values, depending on the model:

- Models with 0.1 dB step size:
  - Attenuation =  $82 \times 0.1 = 8.2$  dB
- Models with 0.25 dB step size:
  - Attenuation =  $82 \times 0.25 = 20.5$  dB
- Models with 0.5 dB step size:
  - Attenuation =  $82 \times 0.5 = 41$  dB

### See Also

[Set Attenuation](#)

[Read Attenuation \(Decimal\)](#)

## 6.2 (e) - Read Attenuation (Decimal)

This function returns the current RF attenuation setting precisely (including decimal places).

### Command

**A**

### Return Value

[a]

Where:

[a] = attenuation

### Example

Send the text command "A\r".

The response would be in the format "20.25" to indicate the attenuation is set at 20.25dB.

### See Also

[Set Attenuation](#)

[Read Attenuation \(Integer\)](#)

## 6.2 (f) - Send SCPI Command

This function sends a SCPI command to the programmable attenuator and collects the returned acknowledgement. SCPI (Standard Commands for Programmable Instruments) is a common method for communicating with and controlling instrumentation products and in this case provides access to an enhanced set of functions / operations for the attenuator.

### Command

**P** [c]

Where:

[c] = SCPI command to send

### Return Value

[r]

Where:

[r] = SCPI response

### Example

To query the model name using SCPI:

- [c] = :MN?

Send the text command "P:MN?\r".

The response would be in the format of "MN=RCDAT-6000-90" for model RCDAT-6000-60.

### See Also

[Summary of SCPI Commands / Queries](#)