

# Centrometal

## HEATING TECHNIQUE

Centrometal d.o.o. - Glavna 12, 40306 Macinec, Croatia, tel: +385 40 372 600, fax: +385 40 372 611

ENG

## Technical manual



## Controller CPREG-Touch - USER



THE FIRST COMMISSIONING MUST BE CARRIED OUT BY AN AUTHORIZED PERSON, OTHERWISE THE PRODUCT WARRANTY IS NOT VALID.

CPREG-Touch

*EKO-CK P + Cm pelet-set 14-90*  
*EKO-CKB P + Cm pelet-set 14-50*

BOOK 2/2



These instructions are an integral part of this product. All rights reserved. Reproduction of content of this document and transfer to third parties is not allowed without written approval from manufacturer.

Make sure the instructions are always with the device, even if its sale / transfer of another owner to the user or staff authorized for maintenance or repairs to consult.



**READ THESE INSTRUCTIONS CAREFULLY BEFORE INSTALLING THE BOILER TO HEATING SYSTEM.**



**Boiler must not be used by children or disabled persons (either physically or mentally), as well as by person without knowledge or experience, unless they are under control or trained by a person responsible for their safety. Children must be supervised in the vicinity of the product.**



**Boiler must not operate in flammable and explosive environment.**



**Before any work on the boiler, electric energy must be switched off.**



**Please note that the installation can only be performed by a qualified heating contractor or service organization. Any work on electrical and fuel carrying components must be done by a qualified service technician.**

**Commissioning and maintenance can only be performed by a authorized service center. Any work on electrical and fuel carrying components must be done by a qualified service technician.**

## INTRODUCTION

CPREG-Touch Digital controller is an integral part of pellet heating equipment EKO-CK (B) P + Cm Pellet-set. It is installed on boilers EKO-CK P and EKO-CKB P and is connected to pellet burners CPPL 14-90 kW which leads as needed for heating and preparation of domestic hot water (DHW).

### Boiler control CPREG-Touch characteristics:

microprocessor control, safety thermostat, safety pressure, microswitch for lower boiler door, controller turns the burner ON and OFF according to set temperatures and operating modes, regulates the pellet supply via the pellet feeder, operation according to (heating and DHW) or (only DHW) mode, notes the current boiler status on the screen, error writings on the screen

Boiler controller components used by a user:

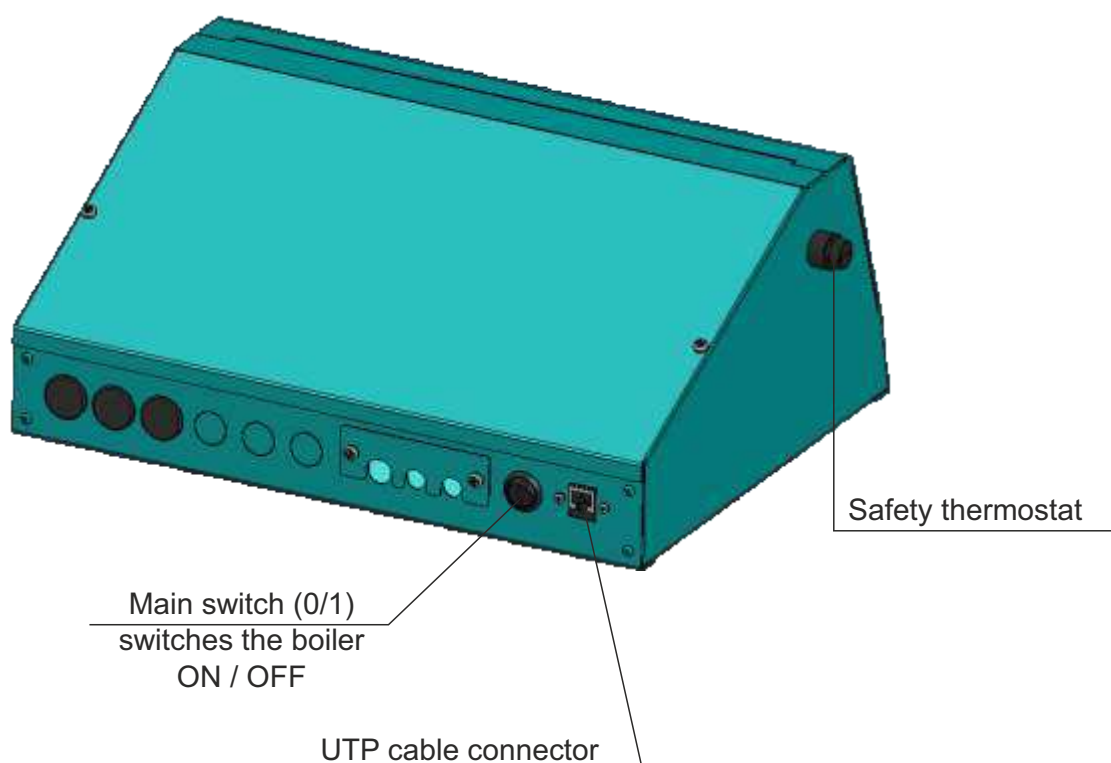

## EQUIPMENT COMPONENTS FOR PELLET BURNINGS CM PELET-SET

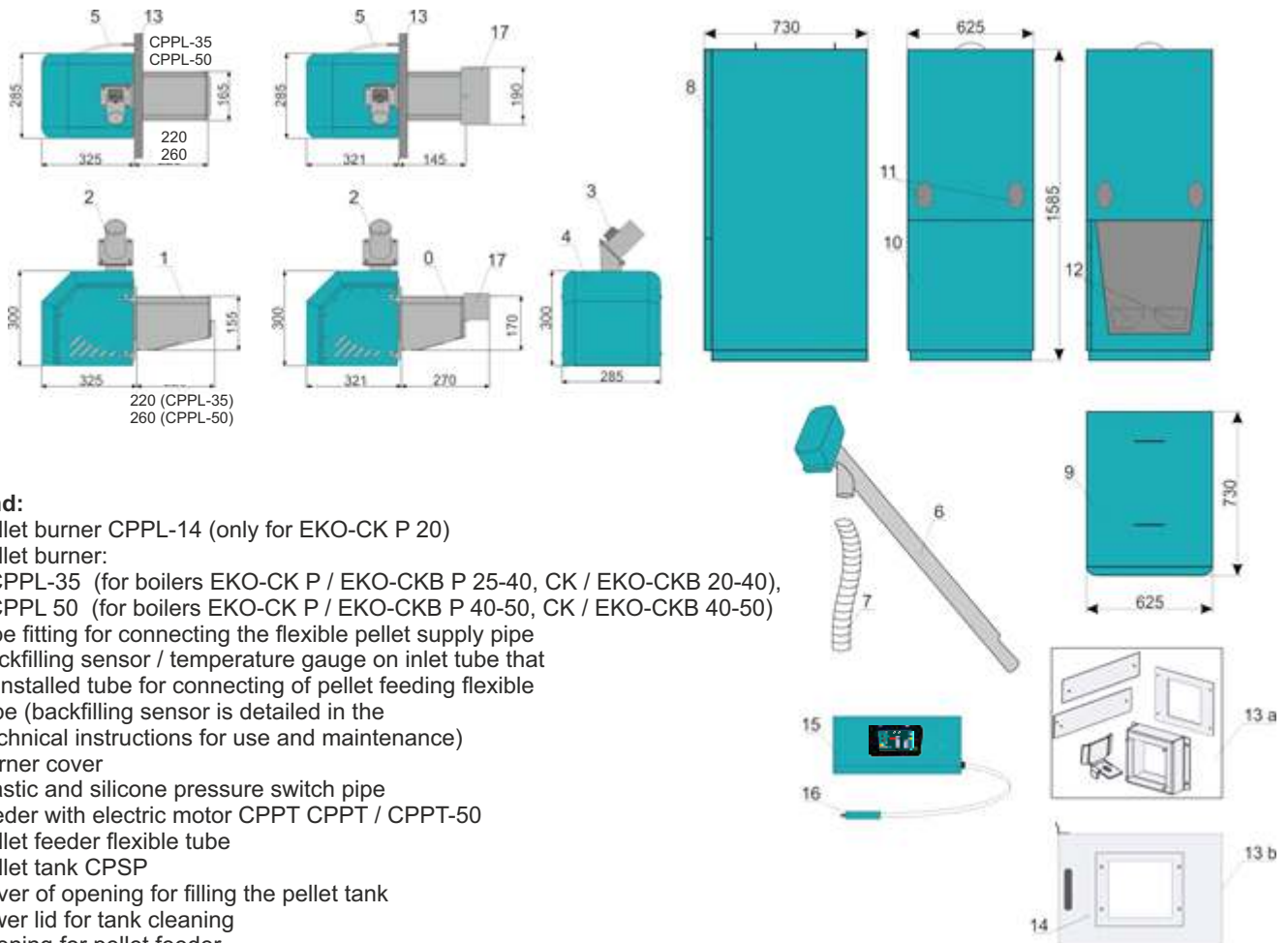

**Legend:**

0. pellet burner CPPL-14 (only for EKO-CK P 20)
1. pellet burner:
  - CPPL-35 (for boilers EKO-CK P / EKO-CKB P 25-40, CK / EKO-CKB 20-40),
  - CPPL 50 (for boilers EKO-CK P / EKO-CKB P 40-50, CK / EKO-CKB 40-50)
2. pipe fitting for connecting the flexible pellet supply pipe
3. backfilling sensor / temperature gauge on inlet tube that is installed tube for connecting of pellet feeding flexible tube (backfilling sensor is detailed in the Technical instructions for use and maintenance)
4. burner cover
5. plastic and silicone pressure switch pipe
6. feeder with electric motor CPPT CPPT / CPPT-50
7. pellet feeder flexible tube
8. pellet tank CPSP
9. cover of opening for filling the pellet tank
10. lower lid for tank cleaning
11. opening for pellet feeder
12. openings for tank cleaning
- 13.a) set for installation of pellet burner (only new boiler models)
- 13.b) lower boiler door adapted for pellet burner CPDV (for boilers EKO-CK P / EKO-CKB P (EKO-CK/CKB)) (only old boiler models)
14. connector for pressure switch silicone pipe on the lower boiler door CPDV
15. boiler control unit CPREG-Touch
16. micro switch for lower boiler door
17. ceramic nozzle (only CPPL-14)

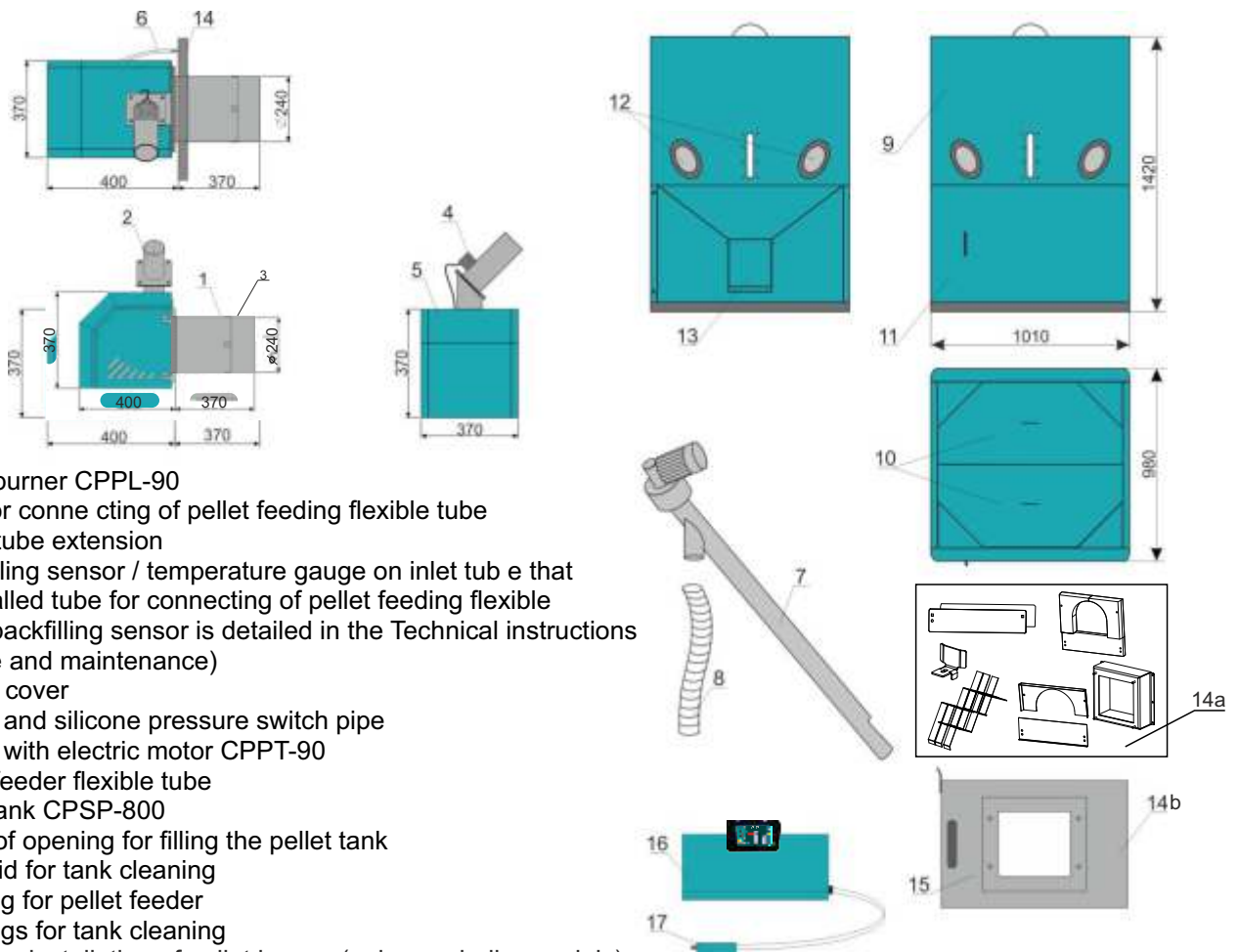

**Legend:**

1. pellet burner CPPL-90
2. tube for connecting of pellet feeding flexible tube
3. flame tube extension
4. Backfilling sensor / temperature gauge on inlet tube that is installed tube for connecting of pellet feeding flexible tube (backfilling sensor is detailed in the Technical instructions for use and maintenance)
5. burner cover
6. plastic and silicone pressure switch pipe
7. feeder with electric motor CPPT-90
8. pellet feeder flexible tube
9. pellet tank CPSP-800
10. cover of opening for filling the pellet tank
11. lower lid for tank cleaning
12. opening for pellet feeder
13. openings for tank cleaning
14. a) set for installation of pellet burner (only new boiler models)
14. b) lower boiler door adapted for pellet burner CPDV 60/70 for burner CPPL-90 (for boilers EKO-CK P 60 and 70) and CPDV 90/110 (for boilers EKO-CK P 90) (only old boiler models)
15. connector for pressure switch silicone pipe on the lower boiler door CPDV
16. boiler control unit CPREG-Touch
17. micro switch for lower boiler door

## STATUS OF DELIVERY

- **temperature sensors PT1000** (2 pcs. for storage tank, 2 pcs. flow line, 1 pcs. domestic hot water and 1 pcs. outdoor sensor)
- **code key** (14kW / 20-35kW / 40-50kW / 60-90kW), in a nylon bag (an authorized service technician must install the correct code key depending on the burner power to which the CPREG-Touch control is connected))

### Temperature sensors that come with controller:

- 1 x sensor boiler (PT 1000)-PVC, factory installed
- 1 x outdoor sensor (PT 1000), in its own cardboard box
- 5 x sensor (PT 1000)-PVC, (including 2 x (PVC handhold, PVC shoelace, paste for mounting sensors on the pipe)), in a nylon bag

### Safety thermostat (STB) (factory installed to the controller):

- STB thermostat switch-off temperature 110-9 °C

## ADDITIONAL EQUIPMENT

**CAL set for alarm (speaker / light )**



**Cm Wifi-box (Internet boiler operation monitoring)**



**GSM module for the alarm alert by mobile network**



**CM2K modul for steering 2+ heating circuits**



**Vacuum supply of pellets**



**CMNET module for steering the boiler cascades**



**Room corrector (CSK)**



**Room corrector (CSK-Touch)**



- air cleaning
- burner flap (14-50)
- pellet level sensor in the tank CPSP / CPSP 70-110

## **INSTALLATION OF THE PELLETT CONTROLLER**

### **INSTALLATION OF THE PELLETT CONTROLLER TO THE BOILER**

- remove the perforated part of the upper boiler cover and through the hole place the safety thermostat sensor and boiler temperature sensor (regulation) in the boiler sleeve (on EKO-CK P + Cm Pelet-set on upper part of the boiler, on the EKO-CKB P + Cm Pelet-set from the front side of the boiler - run the sensors to the sleeve on the lateral side of the boiler).
- connect the 4-pole and 6-pole connectors to the burner and fasten the connectors to the burner body bolts. Attach the wire cable between the regulation and the burner to the boiler with the supplied plastic retainers (secure the cable holder to the boiler using the 3,9 x 16 mm lattice bolts).
- in the lower left or right corner of the front lower boiler cover insert the microswitch (1) (depending on the direction of opening the lower boiler openings) (3), fasten it with 2 screws, adjust the microswitch cover (2) as shown and tighten it with the screw. Check that the pellet door (4), when closed, presses the microswitch (see figure below).
- according to the technical instructions for the assembly of the pellet tank and pellet transporter prepare the pellet tank CPSP and place it on the right or left side of the boiler on the horizontal surface. The boiler and the tank must be set to the same level and you need to align the front side cover of the tank with the front side cover of the boiler.
- in the pellet tank place the pellet transporter for feeding of the pellet CPPT and with a transparent flexible tube connect it with the pellet burner CPPL. One end of the transparent flexible tube is touched to the burner (to the feeding tube) to the filling sensor / temperature gauge on the inlet pipe in the burner, and the other end to the transporter so that the tube can not fall off. The transparent tube must be as flat as possible between the transporter and the burner so that the pellets can freely descend from the transporter to the burner (in case the pellets are retained in the tube, the tube must be leveled or if necessary, shorten the PVC tube).
- The power cable for the screw conveyor (CPPT) should be connected to the connector (2) at the rear of the CPREG-Touch control unit.
- connect the CPREG-Touch controller power supply to the appropriate input on the printed circuit board (PCB) in the CPREG-Touch control unit. The power supply of the CPREG-Touch control **MUST NOT** be connected via the factory-installed pump thermostat on the back of the boiler cover.
- connect the built-in pumps and accessories to the appropriate outputs on the CPREG-Touch controller board according to el. schemes (connection of certain elements to certain outputs depends on the selected configuration and additional equipments).

Safety elements of the CPREG-Touch controller:

- safety thermostat via controller CPREG-Touch switch off the fan operation of the burner and pellet transporter when temperature in the boiler goes over 110°C (+0°C / -9°C).

### Microswitch installation

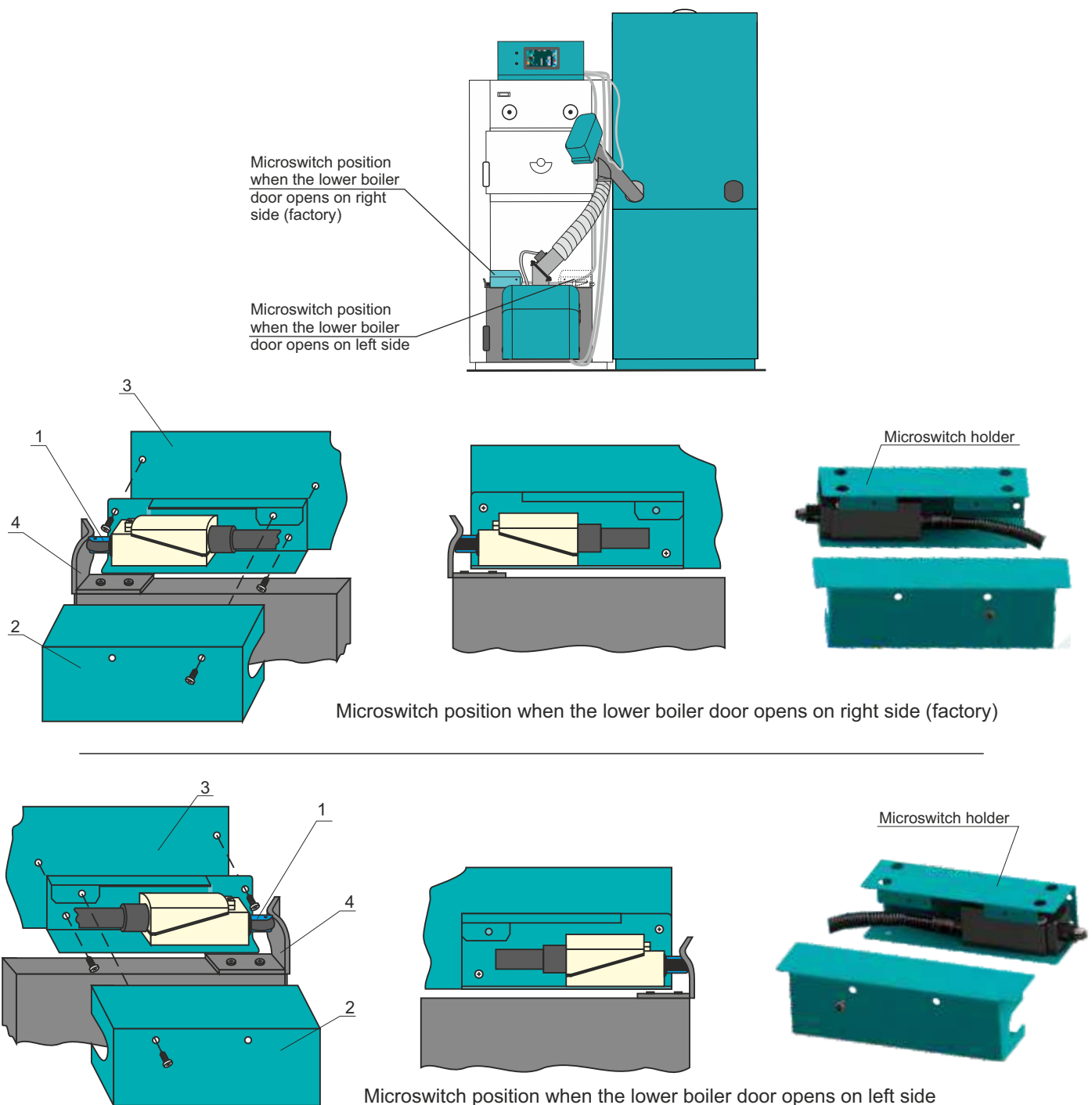

At standard delivery (lower boiler door opens on right side) microswitch is installed on front lower side of boiler casing cover (casing cover side have prepared holes for installing microswitch with holder).

At installation on boiler on which is changed lower boiler door opening direction (lower boiler door opens on left side) is necessary to dismantle microswitch from holder (it's fasten to holder with two screw and two nuts), rotate it on opposite direction and fasten it with same screws and nuts.

After that, microswitch is install to lower front right side of boiler casing cover (casing cover side have prepared holes for installing microswitch).

## INSTALLATION OF CODE KEY IN CONTROLLER (PERFORMED ONLY BY AN AUTHORIZED SERVICER)

- Prior to switching on the control unit for the first time, the authorized service technician must install the correct code key (depending on the burner power (14kW / 20-35kW / 40-50kW / 60-90kW) to which the CPREG-Touch control unit is connected) in the place intended for the code key on the control board. (picture a)

Code keys are delivered in a nylon bag with CPREG-Touch controller.

Mark on code key	Burner power
14	14 kW
35	20-35 kW
50	40-50 kW
90	60-90 kW

Picture a) Example of code key installation 20-35kW

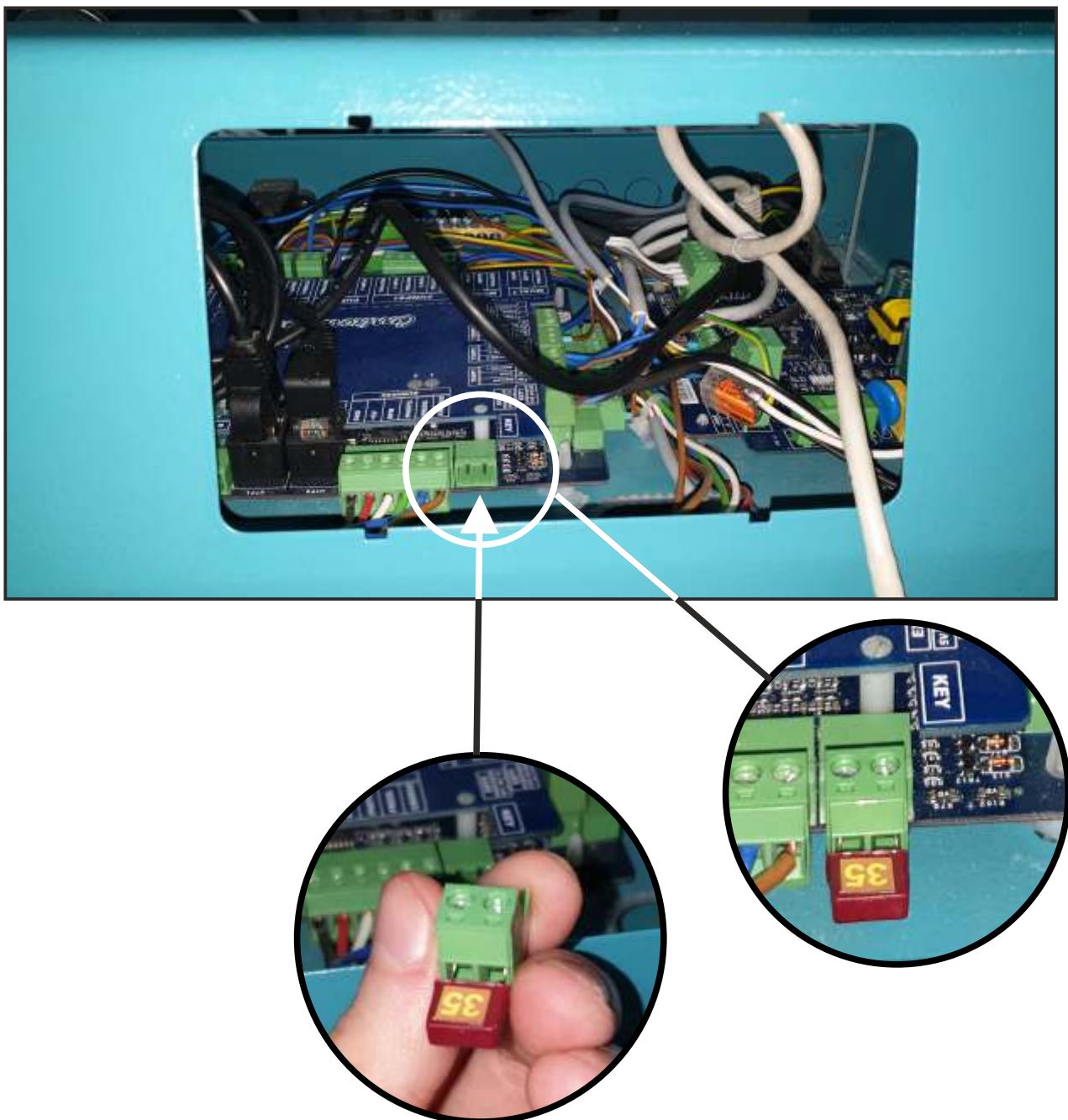

### TYPE OF HEATING SYSTEMS - CLOSED AND OPEN HEATING SYSTEMS

Basic scheme of EKO-CK (B) P + Cm Pelet-set boiler installation **on closed** heating system

Scheme 1)

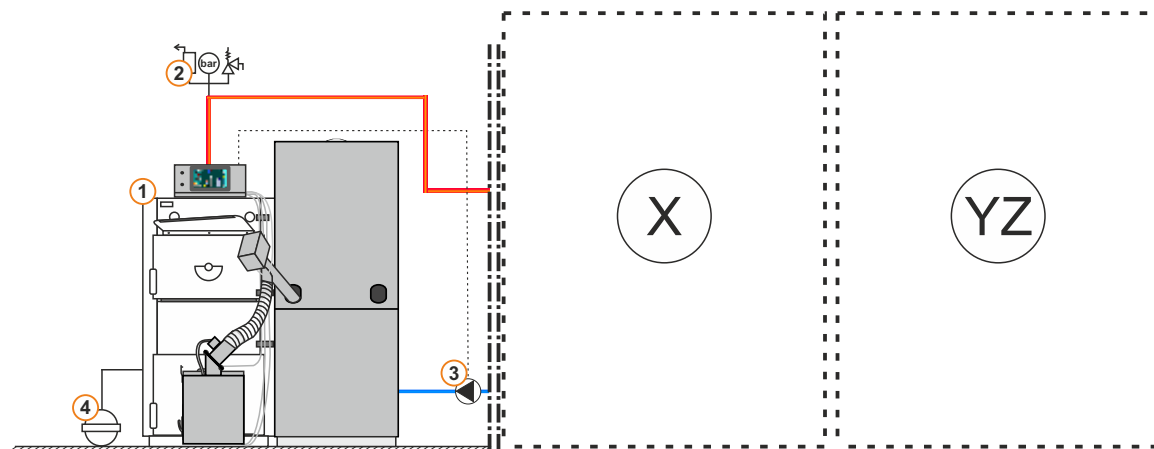

Basic scheme of EKO-CK (B) P + Cm Pelet-set boiler installation **on open** heating system

Scheme 2)

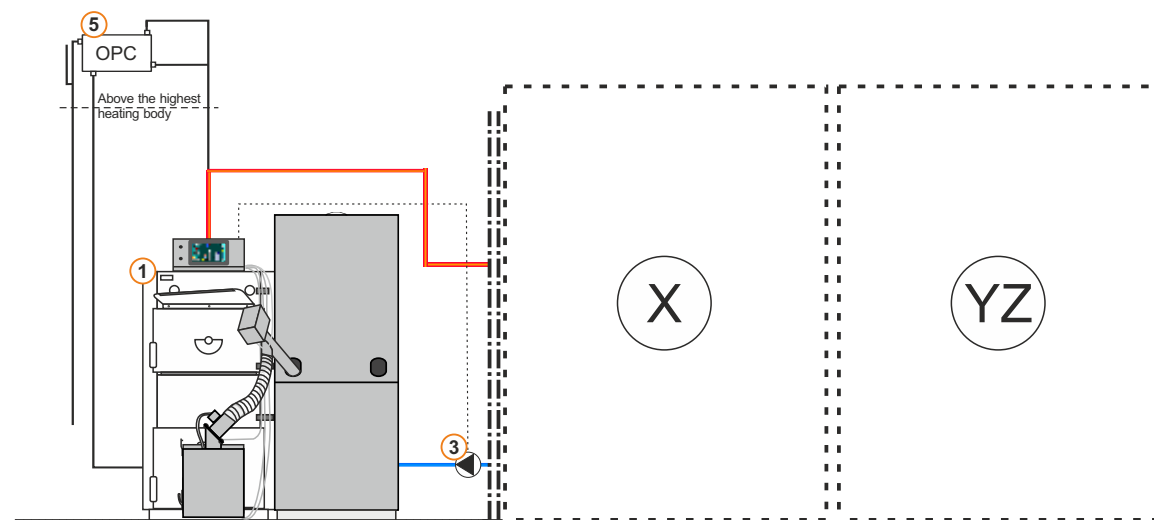

#### Legend:

1. Boiler EKO-CK P + Cm Pelet-set (14-90) or boiler EKO-CKB P + Cm Pelet-set (14-50)
  2. Safety-vent group (safety valve 2,5 bar)
  3. Pump P1
  4. Closed expansion vessel (approximately 10% of the total volume of the installation)
  5. Open expansion vessel (approximately 7% of the total volume of the installation)
- X. - Installation of the boiler on heating system and backflow protection  
YZ. - Heating circuits and DHW

#### REMARK:

Boilers EKO-CKB P + Cm Pelet-set must have a install expansion vessel and safety valve for DHW. The manual shut-off valves are not shown on the schemas.

All boilers can be installed on a close or open heating system. Below the instructions, all schemes are shown with installation on an close heating system.

**HEATING SYSTEM AND BACKFLOW PROTECTION INSTALLATION SCHEME (first mark X, configuration  YZ)**

**Scheme 1) - configurations  A YZ**

A - boiler connection to the ACCUMULATION TANK via 3-way thermostatic valve (60°C backflow protection)

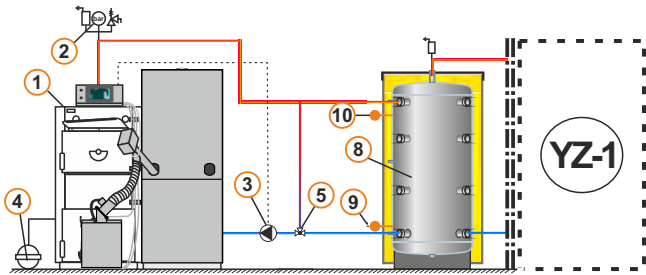

**Scheme 2) - configurations  B YZ**

B - boiler connection to the ACCUMULATION TANK via 3-way valve with actuator (backflow protection)

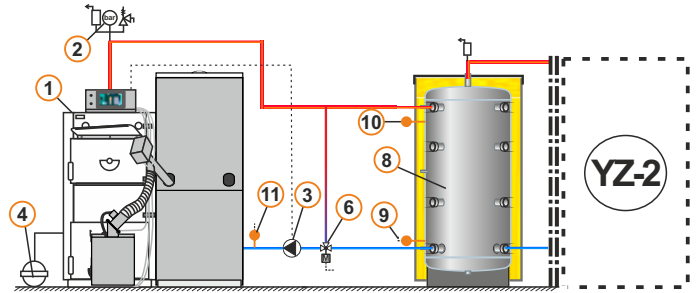

**Scheme 3) - configurations  C YZ**

C - boiler connection to the HYDRAULIC CROSSOVER via 3-way thermostatic valve (60°C backflow protection)

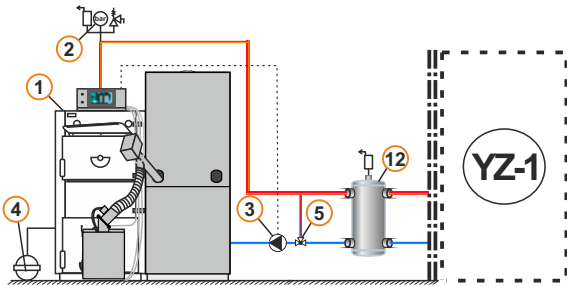

**Scheme 4) - configurations  D YZ**

D - boiler connection to the HYDRAULIC CROSSOVER via 3-way valve with actuator (backflow protection)

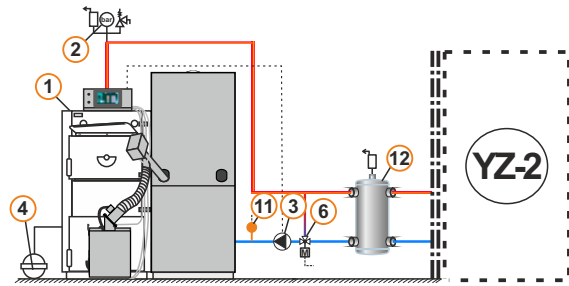

**Scheme 5) - configurations  E YZ**

E - boiler connection to the HYDRAULIC CROSSOVER+SENSOR via 3-way thermostatic valve (60°C backflow protection)

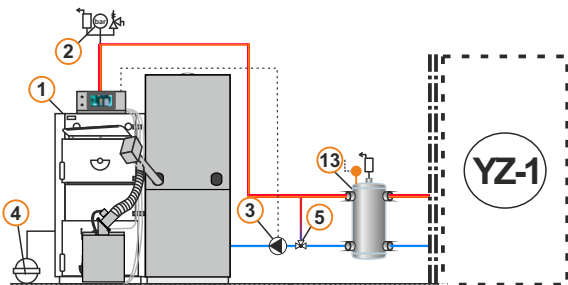

**Scheme 6) - configurations  F YZ**

F - boiler connection to the HYDRAULIC CROSSOVER+SENSOR via 3-way valve with actuator (backflow protection)

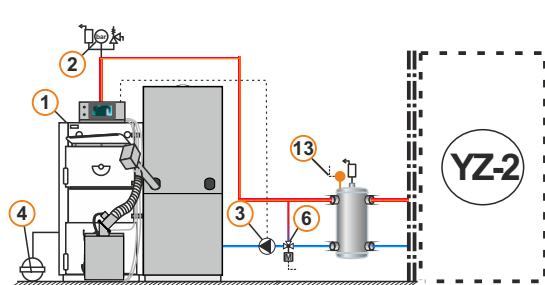

# Boiler installation with the central heating installation

## Scheme 7) - configurations **H** YZ

H - boiler connection to the 4-WAY VALVE with actuator (backflow protection)

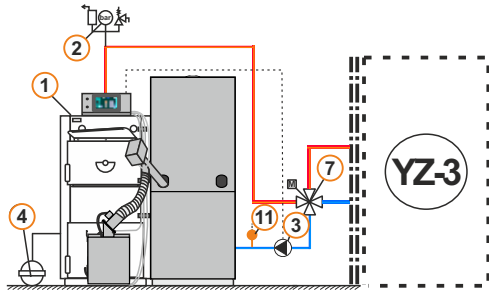

## Scheme 8) - configurations **I** YZ

I - boiler connection to the ACCUMULATION TANK via 4-way valve with actuator (backflow protection)

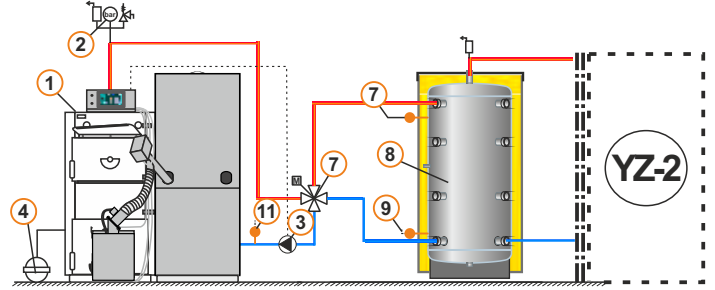

## Scheme 9) - konfiguracije **J** YZ

J - boiler connection to the HIDRAULIC CROSSOVER via 4-way valve with actuator (backflow protection)

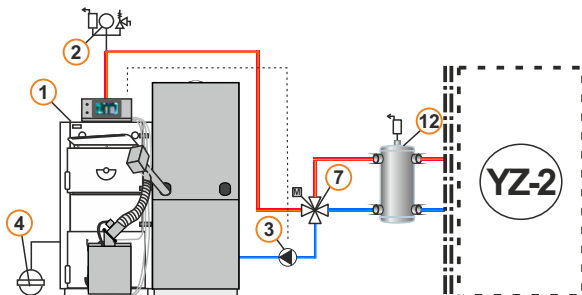

## Scheme 10) - configurations **K** YZ

K - boiler connection to the HYDRAULIC CROSSOVER + SENSOR via 4-way valve with actuator (backflow protection)

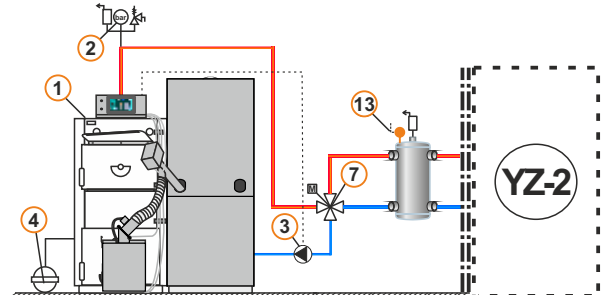

### Legend:

1. Boiler EKO-CK (B) P + Cm Pelet-set
  2. Safety-vent group (safety valve 2,5 bar)
  3. Pump P1
  4. Closed expansion vessel
  5. (variant - 1) - backflow protection:  
- 3-way mixing valve (min. 60 C )
  6. (variant - 2) - backflow protection:  
- 3-way mixing valve with actuator
  7. (variant - 3 / variant - 4 if the heating circuits and DHW are directly connected to 4-way mixing valve)  
- Backflow protection  
- 4-way mixing valve with actuator
  8. Accumulation tank
  9. Lower sensor of the accumulation tank (BUFFER2)
  10. Upper sensor of the accumulation tank (BUFFER1)
  11. Backflow sensor
  12. Hydraulic crossover HS
  13. Hydraulic crossover HS + sensor HS (BUFFER1)
- YZ-1 - Heating circuits and DHW - (variant - 1 - backflow protection)  
 YZ-2 - Heating circuits and DHW - (variant - 2 - backflow protection)  
 YZ-3 - Heating circuits and DHW - (variant - 3 - backflow protection)  
 YZ-4 - Heating circuits and DHW - (variant - 4 - backflow protection)

### Remark:

Manual shut-off valves and expansion vessel for DHW are not shown on the schemas.

## HEATING CIRCUITS AND DHW (second and third configuration symbols X Y Z)

**Important:** For easy managing use YZ - variants from the previous point 5.5)

### a) 1 heating circuit with mixing valve

POSSIBLE FOR: YZ-1 YZ-2 YZ-3 YZ-4

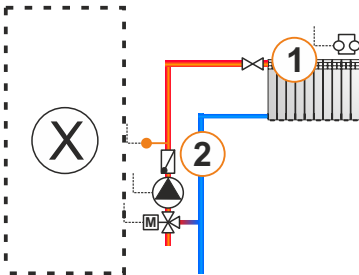

Possible configurations: X 01, X 71, X 81

X = "A", "B", "C", "D", "E", "F", "H", "I", "J", "K"

### b) 2 heating circuits with mixing valve

POSSIBLE FOR: YZ-1 - - YZ-4

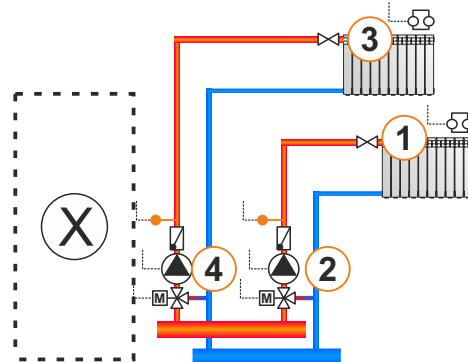

Possible configurations: X 02, X 72, X 82

X = "A", "C", "E"

### c) the DHW tank circuit

POSSIBLE FOR: YZ-1 YZ-2 YZ-3 YZ-4

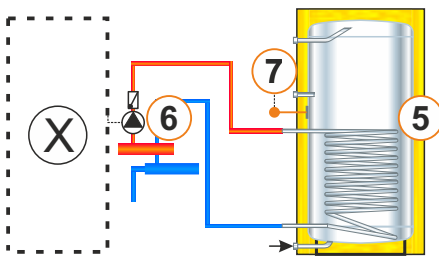

Possible configurations: X 10

X = "A", "B", "C", "D", "E", "F", "H", "I", "J", "K"

### d) 1 heating circuit with mixing valve and DHW tank

POSSIBLE FOR: YZ-1 YZ-2 YZ-3 YZ-4

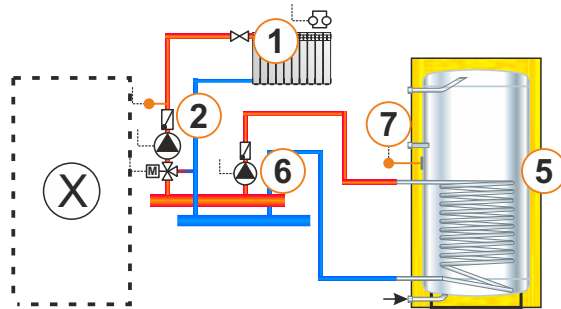

Possible configurations: X 11

X = "A", "B", "C", "D", "E", "F", "H", "I", "J", "K"

### e) 2 heating circuits with mixing valve and DHW tank

POSSIBLE FOR: YZ-1 - - YZ-4

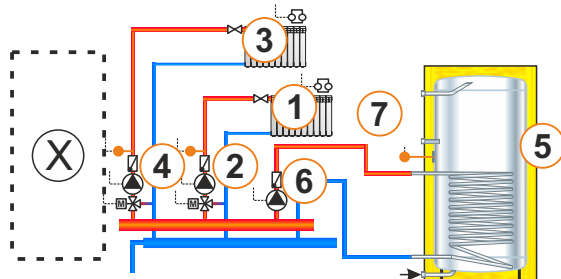

Possible configurations: X 12

X = "A", "C", "E"

### f) the DHW tank circuit with recirculation

POSSIBLE FOR: YZ-1 YZ-2 YZ-3 YZ-4

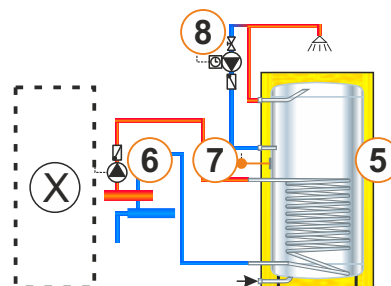

Possible configurations: X 20

X = "A", "B", "C", "D", "E", "F", "H", "I", "J", "K"

# Boiler installation with the central heating installation

## g) 1 heating circuit and DHW tank with recirculation

POSSIBLE FOR: 

YZ-1	YZ-2	YZ-3	YZ-4
------	------	------	------

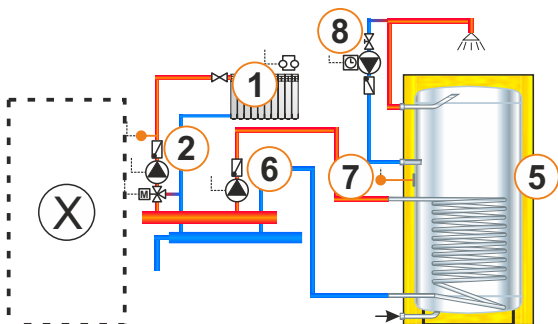

Possible configurations: 

X	21
---	----

X
---

 = "A", "B", "C", "D", "E", "F", "H", "I", "J", "K"

## h) 2 heating circuits and DHW tank with recirculation

POSSIBLE FOR: 

YZ-1	-	-	YZ-4
------	---	---	------

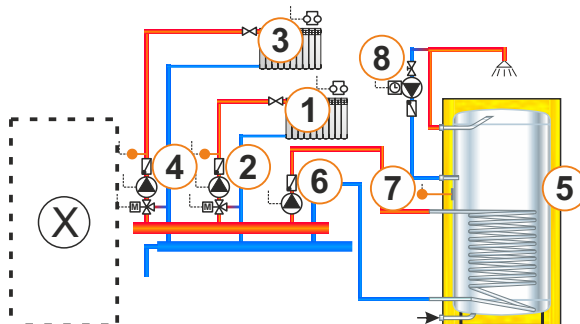

Possible configurations: 

X	02	X	72	X	82
---	----	---	----	---	----

X
---

 = "A", "C", "E"

## \*i) direct heating circuits with pump (one or two heating circuits, depends on the selection)

POSSIBLE FOR: 

-	-	-	YZ-4
---	---	---	------

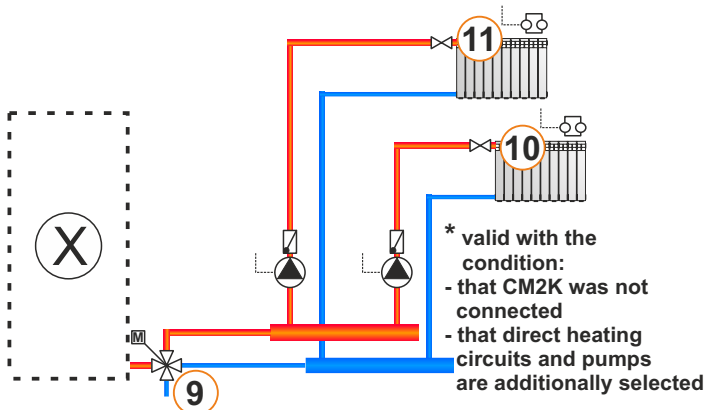

Possible configurations: 

H	00	H	70
---	----	---	----

Remark:  
Possible selection: room corrector or room thermostat

## \*j) direct heating circuits without pump (one or two heating circuits, depends on the selection)

POSSIBLE FOR: 

-	-	-	YZ-4
---	---	---	------

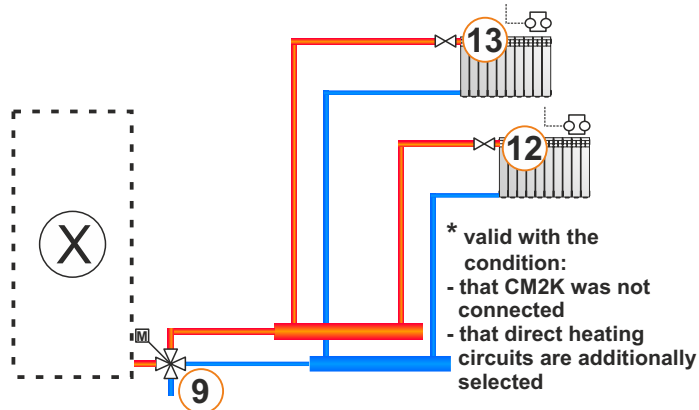

Possible configurations: 

H	00	H	70
---	----	---	----

Remark:  
Possible selection: room corrector or room thermostat

## \*k) direct heating circuits with pump + DHW (one or two heating circuits, depends on the selection)

POSSIBLE FOR: 

-	-	-	YZ-4
---	---	---	------

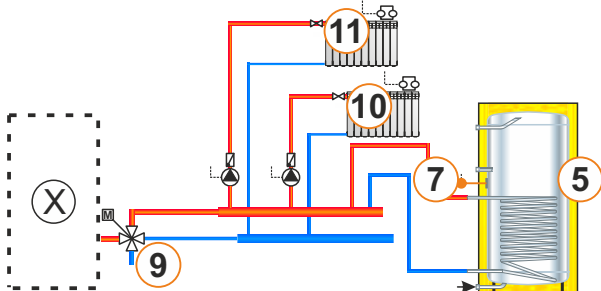

Possible configurations: 

H	10
---	----

Remark:  
Possible selection: room corrector or room thermostat

## \*l) direct heating circuits without pump + DHW (one or two heating circuits, depends on the selection)

POSSIBLE FOR: 

-	-	-	YZ-4
---	---	---	------

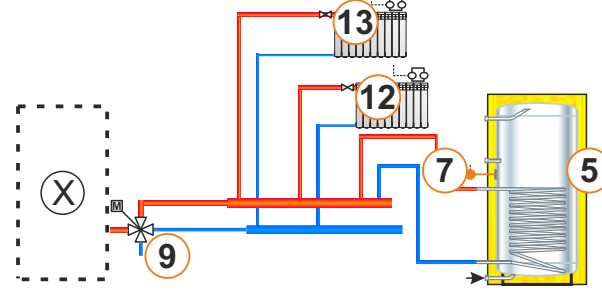

Possible configurations: 

H	10
---	----

Remark:  
Possible selection: room corrector or room thermostat

**\*m) Direct heating circuits with pump + DHW with recirculation (one or two heating circuits, depends on the selection)**

POSSIBLE FOR: 

-	-	-	YZ-4
---	---	---	------

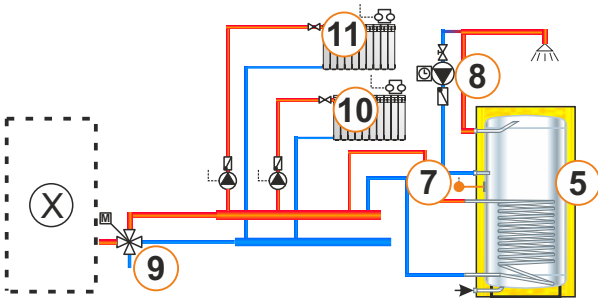

\* valid with the condition:  
 - that CM2K was not connected  
 - that direct heating circuits and pumps are additionally selected

Possible configurations:

**H 20**

Remark:  
 Possible selection: room corrector or room thermostat

**\*n) direct heating circuits without pump + DHW with recirculation (one or two heating circuits, depends on the selection)**

POSSIBLE FOR: 

-	-	-	YZ-4
---	---	---	------

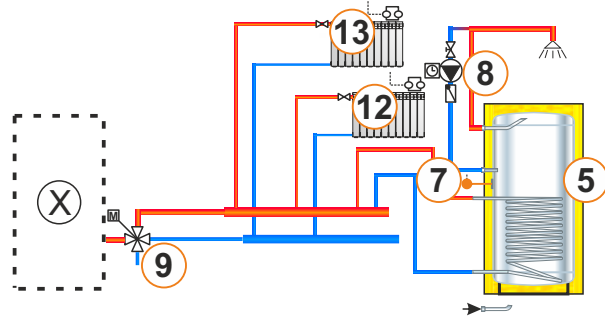

\* valid with the condition:  
 - that CM2K was not connected  
 - that direct heating circuits are additionally selected

Possible configurations:

**H 20**

Remark:  
 Possible selection: room corrector or room thermostat

**Legend:**

- 1 - 1. mixing heating circuit (radiator, floor...)
- 2 - Sensor 1. mixing circuit (**CIRCUIT1**) + pump (**P4**) + actuator (**MVAL1**)
- 3 - 2. mixing heating circuit (radiator, floor...)
- 4 - Sensor 2. mixing circuit (**CIRCUIT2**) + pump (**P5**) + actuator (**MVAL2**)
- 5 - DHW tank
- 6 - DHW tank pump (**P2**)
- 7 - DHW tank sensor (**DHW**)
- 8 - DHW recirculation (**P3**)
- 9 - 4-way mixing valve + actuator (**MVAL2**)
- 10 - Direct heating circuit (radiator) with room thermostat or room corrector + pump (**P4**)
- 11 - Direct heating circuit (radiator) with room thermostat or room corrector + pump (**P5**)
- 12 - Direct heating circuit (radiator) with room thermostat or room corrector + pump
- 13 - Direct heating circuit (radiator) with room thermostat or room corrector + pump

**Remark:**

Manual shut-off valves and expansion vessel for DHW are not shown on the schemas.

**INSTALLATION OF A 3-WAY / 4-WAY MIXING VALVE WITH ACTUATOR**

A three-way or four-way mixing valve with a motor in the backflow protection function can be installed on the left or right side of the boiler, see examples of installation on the right side of the boiler (Example 1 and Example 2). Example 1 shows a 3-way mixing valve, and Example 2 shows a four-way mixing valve. Installing the mixing valve on the left side of the boiler is the mirror image shown in Example 1 and Example 2. The direction of opening of the actuator must be in accordance with the actual direction of opening for the individual situation, the electric diagram of this technical instructions and directions "Close MV!" and "Open MV!" in a manual control test.

**Installation of the 3-way / 4-way mixing valve (backflow protection)**

**Example 1: 3-way mixing valve**

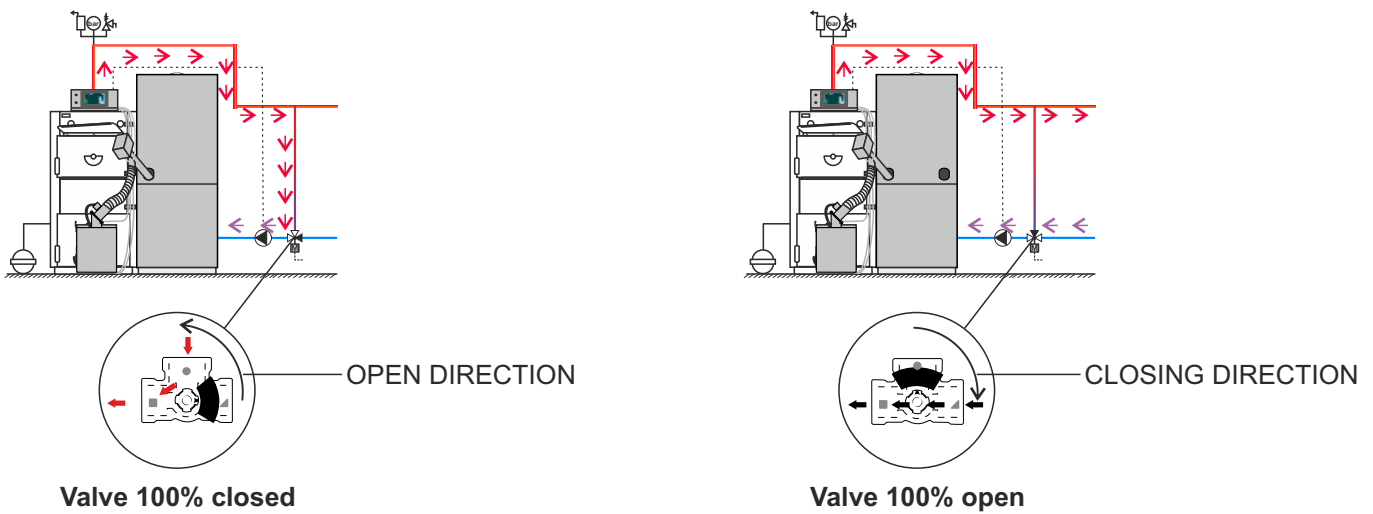

**Example 2: 4-way mixing valve**

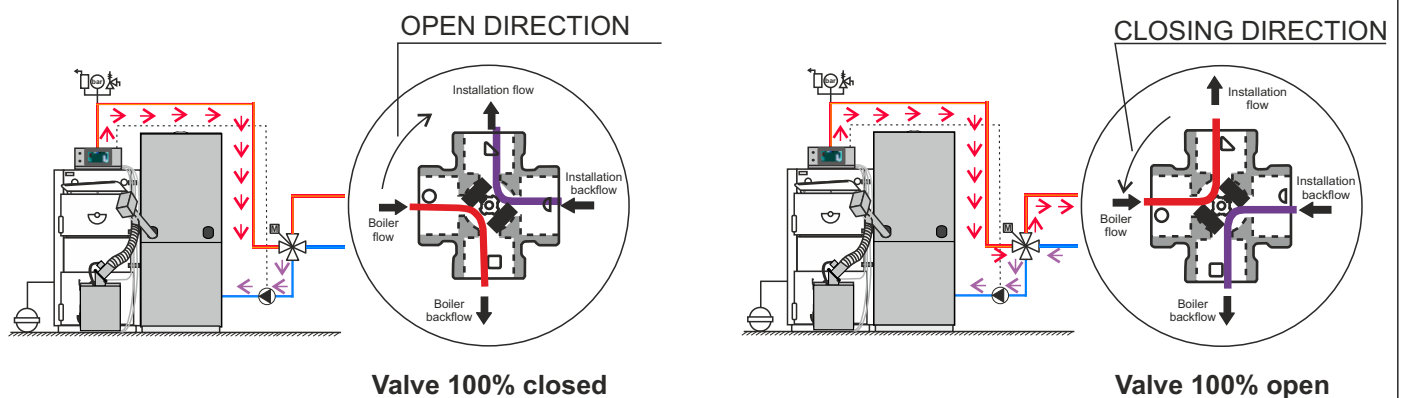

### Actuator installation (backflow protection)

An example of the ESBE actuator installation on a 4-way mixing valve (the pre-installation of a 3-way mixing valve is the same).

1. Engine position when valve is closed.

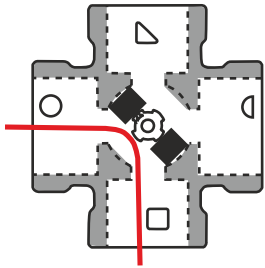

2. Valve position (valve closed) - axle marking (A).

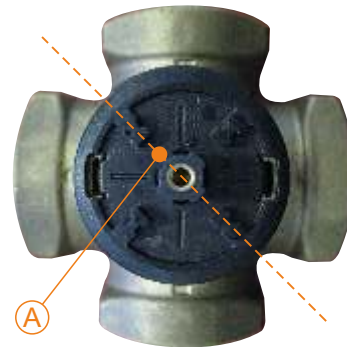
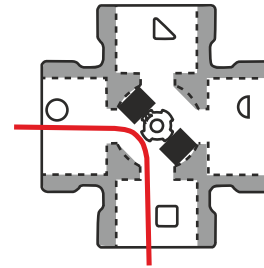

3. The position of the motor-drive clutch position before the drive is installed; the clutch mark (B).

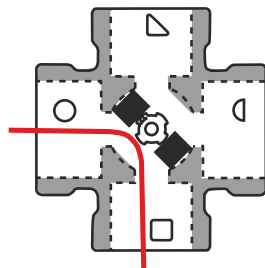
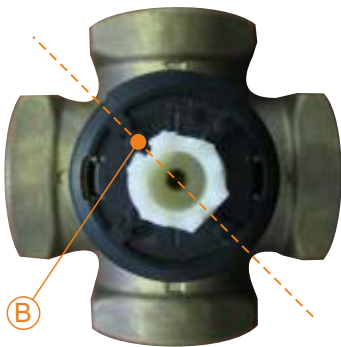

4. Install the actuator as shown in the figure below (the moving part of the actuator must be facing the green stop (C) with the handle of the handle (D)).



5. Tighten the drive clamping screw (when the bolt clamps, the propulsion part of the drive will rotate from right to bottom to the end position)



6. Position the drive handle, tilt it to the left until it reaches the crank position, to set it to DOWN - automatic operation

Drive handle



## Installation of a 3-way / 4-way mixing valve with actuator

7. Position of the drive in the DOWN position (drive handle pressed) - automatic operation; boiler ready for operation



**Valve 100% closed**

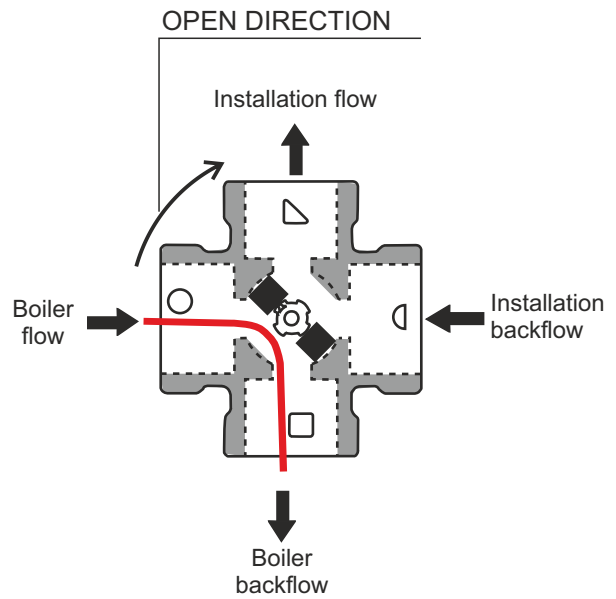

**Valve 100% open**

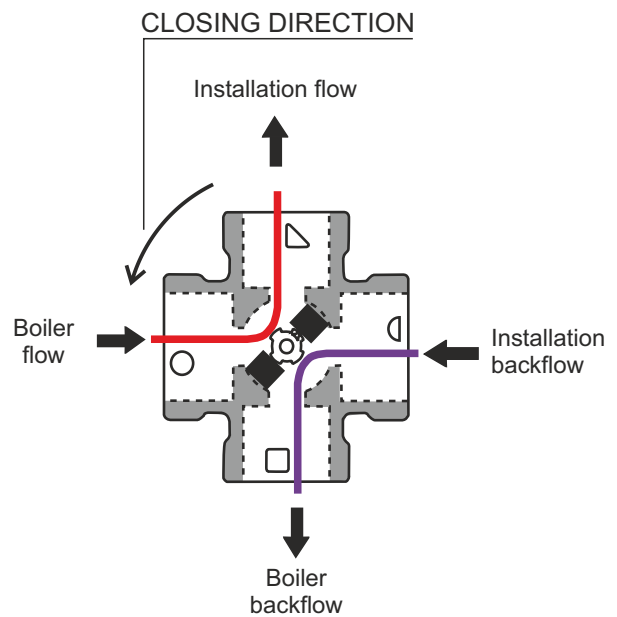

## SWITCHING ON / DISPLAY

After switching the main switch on, the language selection and software version will appear on the screen. You can choose between different languages. To select the preferred language press a flag on display.



If the option "LANGUAGE SELECTION" is "OFF" in the main menu under the name "DISPLAY", the initial message will appear on the screen (see the picture below) and it will stay as long as is set in the submenu "INITIAL MESSAGE TIME" or until you press the "OK" button.



**Touchscreen must not be pressed while switching the main switch on, otherwise the controller will show a firmware update mode, which is used by an authorized person only. If this happens, please switch the main switch off and switch it back on without pressing the touchscreen.**

## THE MAIN MENU

The main menu is used to select a preferred submenu. To enter into a certain menu press an icon on the screen. To switch between the "Main menu" and "Boiler working display" press the "VIEW SELECTION" button. To display drop-down menu (if it is enabled) use the "SHORTCUTS" button.

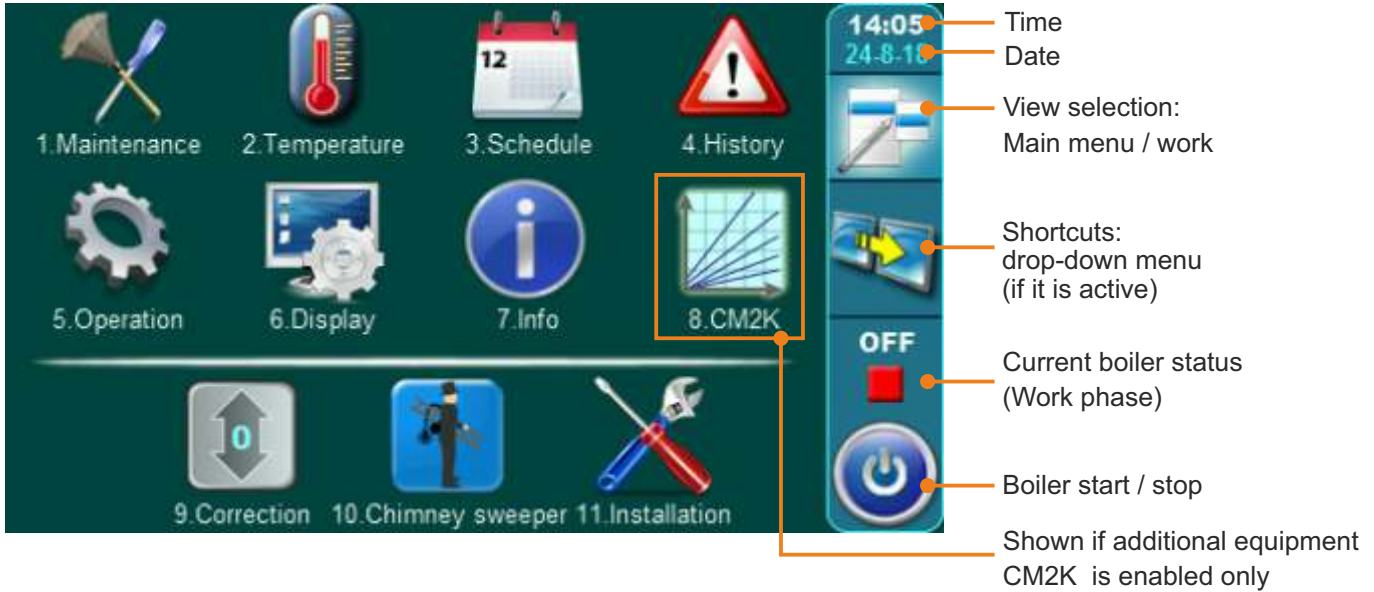

## SYMBOLS



Button "ON / OFF"  
options: on / off boiler operation"



Button "VIEW SELECTION"  
options: main menu / home screen



Button "SHORTCUTS": Drop-down menu (if it is active)"



Button "ENTER"



Button "BACK"



Button "PREVIOUS SCREEN"



Button "NEXT SCREEN"



Button "OK"

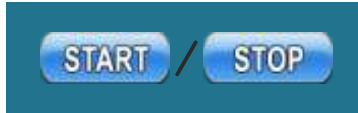

Tipka "START"/"STOP"

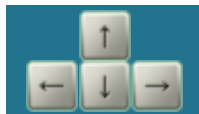

Navigation buttons:  
"LEFT", "RIGHT", "UP", "DOWN"



Button "DELETE"



Button "FACTORY SETTINGS"

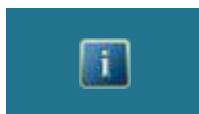

Button "INFORMATION"



Button "COPY"



Button "PASTE"

**SYMBOLS**

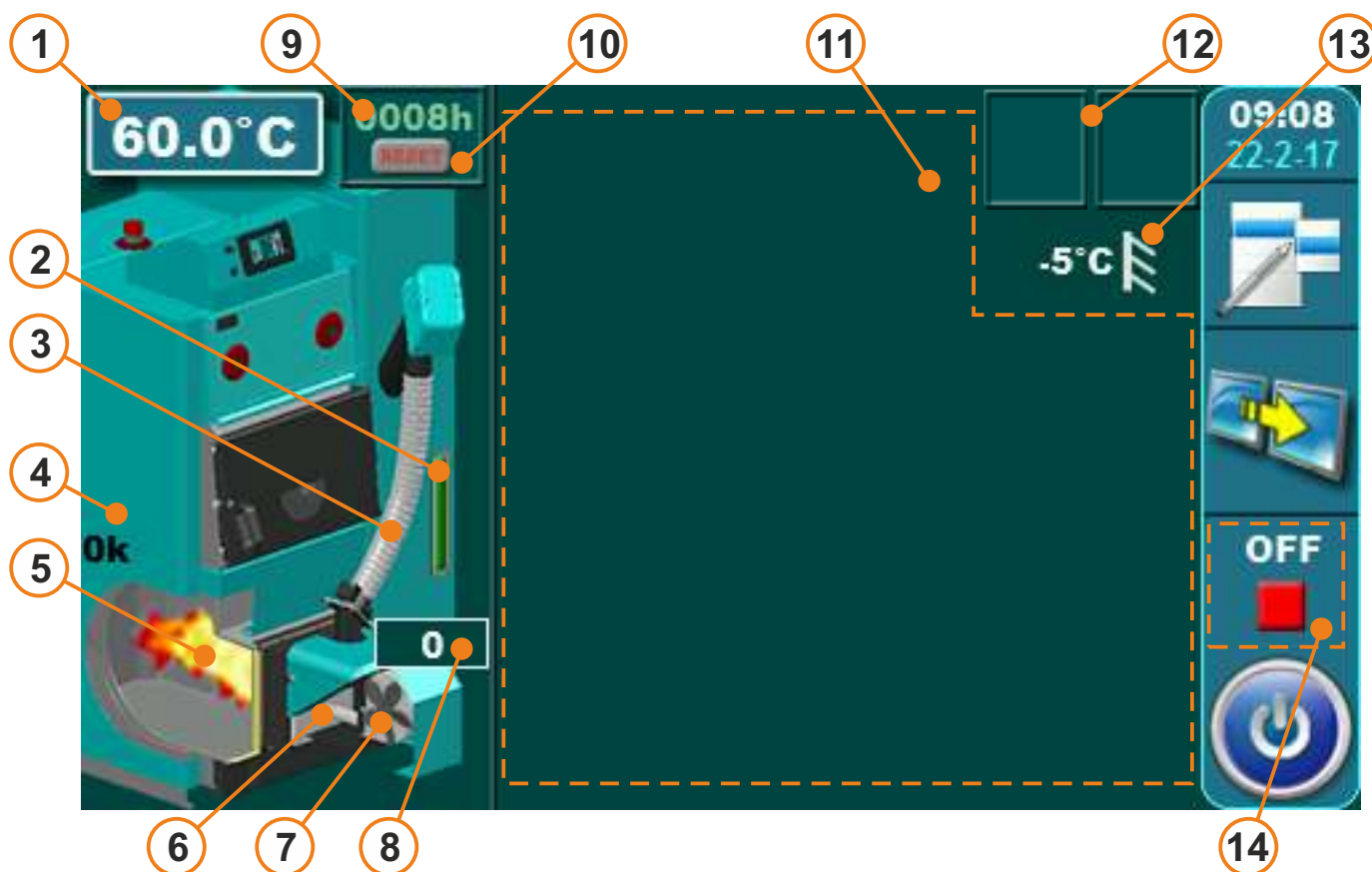

**Symbols:**

- 1 - Boiler temperature
- 2 - Fuel level \*
- 3 - Transporter is working
- 4 - Photocell
- 5 - Flame symbol
- 6 - Igniter is working
- 7 - Burner fan is working
- 8 - Burner fan rpm
- 9 - Burner working hours counter
- 10 - Burner working hours reset button
- 11 - Dynamic configuration view  
(view depends on set configuration)
- 12 - Heating mode / Freeze guard /  
Additional equipment view (cascade, wifi...)
- 13 - Outside temperature
- 14 - Boiler working stage

\* - additional equipment  
on screen only if additional equipment  
is installed and enabled (fuel level sensor)

**Boiler type display:**

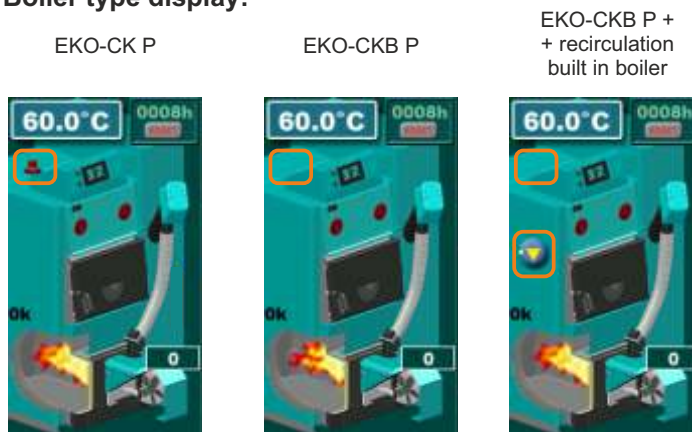

Pump (no demand to work)



Pump has demand to work (when there is demand to work, given by a customer, yellow rectangle appears inside the pump symbol, but pump doesn't work if all the conditions are not fulfilled; i.e. too low temperature in the boiler, otherwise it works). It rotates while working, it doesn't rotate while not working.

**SYMBOLS**



Room thermostat

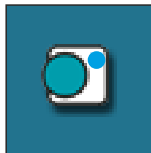

Next to the room thermostat symbol bright blue circle (the room thermostat has requested for operating the pump, the pump does not work if you have not met all the conditions for its operation, for example. low temp. in the boiler, otherwise normally works)



Room corrector symbol show current measured room temperature (20.0°C), set room temperature in controller + set room corrector correction (20.0+5.0°C).



Heating circuit

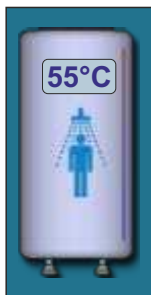

Domestic hot water tank with current temperature



External control – there is a demand



External control – there is no demand



View button / Drop-down menu (all existing elements of automatic / remote boiler start are enabled)



Cascade



View button / Drop-down menu (some of existing elements of automatic / remote boiler start are enabled)



All elements of automatic / remote boiler start are disabled (ON/OFF button is crossed in red)

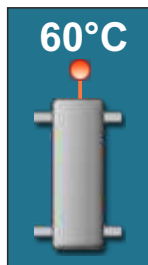

Hydraulic crossover with the current temperature (there are configuration without temp. sensor)



Accumulation tank with current temperature at top of the tank and at the bottom of the tank.



Heating (working mode)



Heating + DHW (working mode)



DHW (working mode)



Cm WiFi-box - not connected



Cm WiFi-box - connected



Option "Freeze guard" is enabled



"Freeze guard" triggered one of the pumps.



The burner start due to "freezing guard" is disabled in drop down menu, freezing protection system works without possibility for burner to work (use the boiler water without the possibility to heat it).



Since freezing guard is enabled, burner is started from the OFF phase. Snowflake disappears if burner is started by schedule, external start, Wifi monitoring, CMGSM, by pressing the ON/OFF button or if it goes to the OFF phase.

### SYMBOLS, THE PARAMETERS ADJUSTING



3-way thermostatic mixing valve  
+ pump



3-way mixing valve with actuator and  
return flow temp. sensor  
+ pump

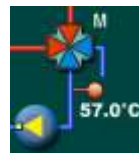

4-way mixing valve with actuator and  
return flow temp. sensor  
+ pump



Current status of existing elements of automatic / remote start is shown on the screen (ON/OFF in a drop-down menu):

#### Shown in the picture:

- Schedule: enabled (status ON)
- Freezing guard: enabled (status ON)
- External control: enabled (status ON)
- WiFi/CM GSM: enabled (status ON)

#### By switching of a certain button to OFF:

- Schedule: disabled
- Freezing guard: boiler start for freezing protection is disabled, but freezing protection is working in a way it can perform without starting the boiler and a half of snowflake and an exclamation mark appear in the upper right corner of the screen
- External control: start from an external source is disabled and crossed external start icon is shown on the screen
- WiFi/CM GSM: boiler start/stop by WiFi/CM GSM module is disabled, other WiFi/CM GSM options are enabled

### THE PARAMETERS ADJUSTING

There are 4 different menu types for adjusting the parameters:

A - this menu is used to set the parameters that have numerical values (°C, RPM, time...)

**example:** adjust the burner fan rpm, adjusting the boiler temp. etc...

B - this menu is used to set parameters that must be selected (marked) to be enabled and there can be multiple selected (enabled) items

NOTE: some enabled options disable another one (they can't be enabled at the same time)

**example:** enable additional equipment: flap, air cleaning, CM2K, Cm-WiFi-box...

C - this menu is used to set the parameters that must be selected but there can be only one selected item

**example:** set the type of the DHW sensor

D - this menu is used to set the parameters where are many items to be adjusted

**example:** adjust the burner working parameters on power P2



A



B



C

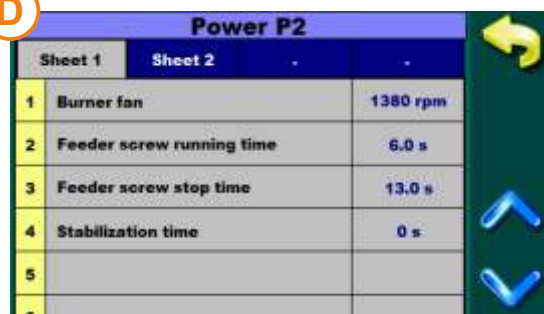

D

**THE PARAMETERS ADJUSTING METHODS (examples)**

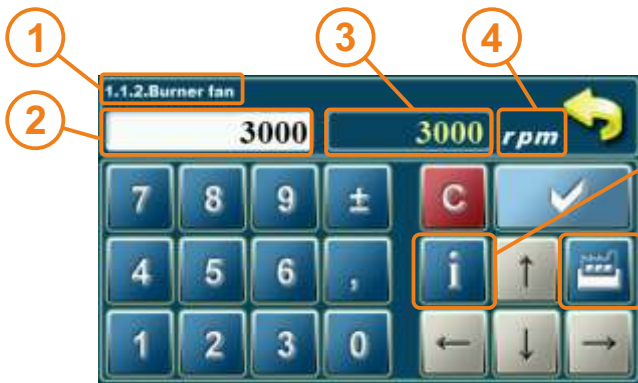

- 1 - parameter you are adjusting
- 2 - value adjustment box
- 3 - set value
- 4 - value type
- 5 - info button (displays factory, min. and max. values)
- 6 - resets the current value to the factory value

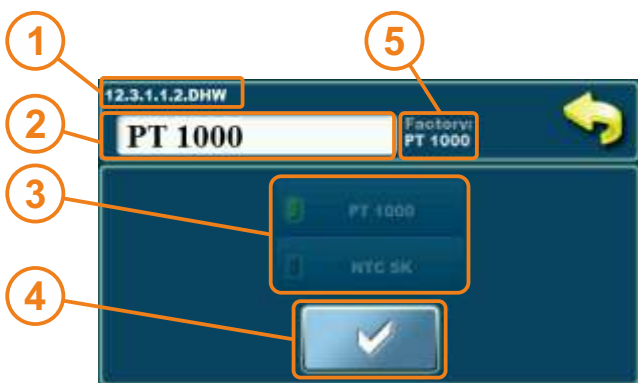

- 1 - parameter you are adjusting
- 2 - value adjustment box
- 3 - selected option (only one option can be selected)
- 4 - confirm button
- 5 - factory value

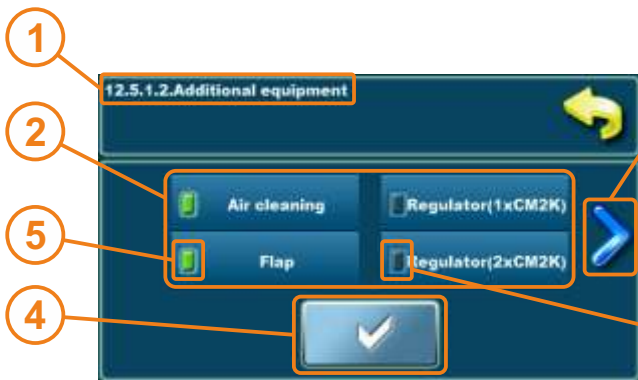

- 1 - parameter you are adjusting
- 2 - items that can be enabled
- 3 - next page button
- 4 - confirm button
- 5 - selected (enabled) item
- 6 - deselected (disabled) item

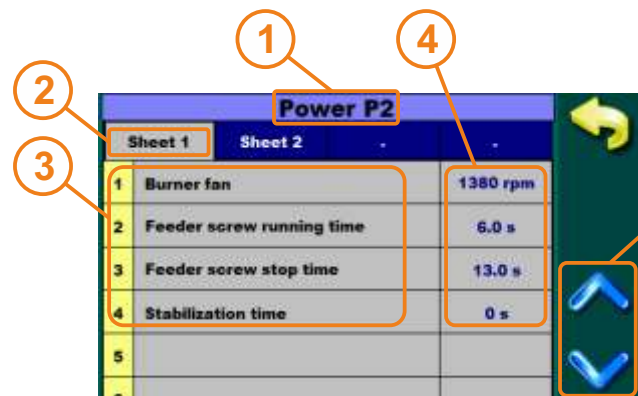

- 1 - parameter you are adjusting
- 2 - switch between sheets (only for parameters which have multiple sheets)
- 3 - parameter description
- 4 - parameter current value (press 2 times to enter adjusting mode)
- 5 - up/down scroll buttons

### BURNER START PROCEDURE (START IS ENABLED)

**The ways to activate "start is enabled" of the burner (burner goes from the OFF phase to the A0 phase (burner starts) or to the S7-3 waiting phase (STANDBY)):**

- manual activation by pressing the ON/OFF button
- activation by schedule (if enabled)
- activation by WiFi or CM GSM module (additional equipment) (if it is enabled in drop-down menu and in "Work mode"/"Additional equipment"/"Internet supervision")

**burner in the waiting phase s7-3 (standby) – causes:**

- set boiler temperature is reached (controller waits the boiler temperature to drop below set difference)
- there is no heating demand (from heating circuits and/or DHW tank) (controller is set to start according to the heating demands)
- external control, that is enabled, turned the boiler off

**Notes:**

Burner may get into the S7-3 waiting phase right after start is activated (from the OFF phase) because one or more of the S7-3 waiting phase causes are fulfilled.

### BURNER STOP PROCEDURE / CONTROLLER STOP PROCEDURE

**Correct ways to stop (turn off) the burner (get to the OFF phase):**

- manual burner stop (turn off) by pressing ON/OFF button if burner is in any phase except the OFF phase (no matter if external control is enabled or disabled)
- burner stop (turn off) by schedule (if enabled) (no matter if external control is enabled or disabled)
- burner stop (turn off) by WiFi or CM GSM (additional equipment) (no matter if external control is enabled or disabled)

**Correct controller stop (turn off) procedure (main switch 0/1)**

- first thing to do is to get the burner into the OFF phase – the burner is turned off (unless it is already in that phase)
- switch off the main switch 0/1 (put it into the 0 position)



#### IMPORTANT NOTES!

- the main switch (0/1) on the controller is not intended for switching the controller on and off
- the burner must be in the OFF phase before switching the controller off on the main switch

## 1.0. MAINTENANCE

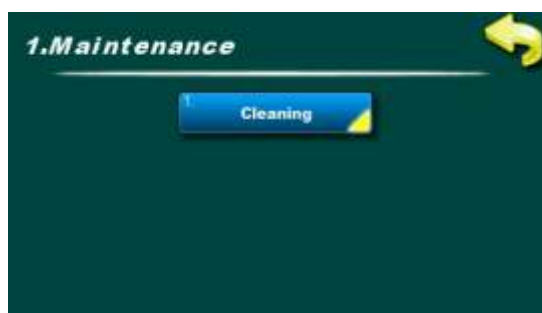

**NOTE:** Burner cleaning option is not a replacement for manual burner and burner grate cleaning. Burner cleaning must be carried out regularly, according to the technical manual.

### 1.1. CLEANING THE BURNER



Under "**CLEANING**" menu are two options:

**Cleaning:** this option is used to start the burner fan on the set RPMs to clean the burner grate (note: depending of the pellets quality grate will be more or less clean. After this procedure, burner grate should be removed and cleaned and the burner head should also be cleaned.)

**Burner fan:** this option sets the burner fan RPMs during cleaning

#### 1.1.1. CLEANING – basic equipment



Press the "**START**" button to start the burner fan for 10 min. After pressing the "START" button countdown is started for 10 min, after which burner fan stops automatically

#### 1.1.1. CLEANING – installed additional equipment – burner air cleaning



Press "**AIR VALVE**" button to open the electro-magnetic valve and to clean the burner with compressed air. After pressing the "AIR VALVE" countdown is started for 60 sec in which time "AIR VALVE" button is disabled to allow compressor to fill its tank.

### 1.1.2. BURNER FAN



This option is used to adjust burner fan RPMs during cleaning procedure.

**Possible adjustment:**

- **Factory adjustment: 3000 rpm**
- Minimal adjustment value: 500 rpm
- Maximal adjustment value: 3000 rpm

## 2.0. TEMPERATURE



Temperature menu shows only items applicable to the set configuration. In next section of the manual all available configurations and schemes are listed.

Available temperature settings will be described at every individual configuration and scheme in "**CONFIGURATIONS**" section of this manual.

**NOTE:** this is only representation picture, actual possible adjustment depends on set configuration.

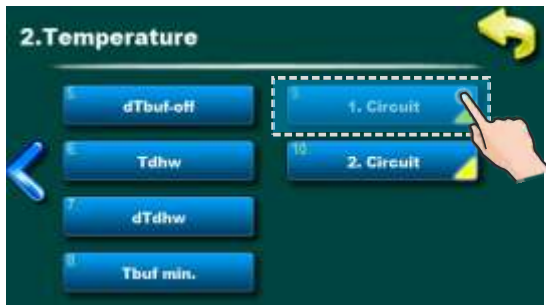

**Possible adjustment:**

Factory: 20.0°C

Option: 5.0 - 30.0°C

This sets up the first heating circuit daily room temperature.

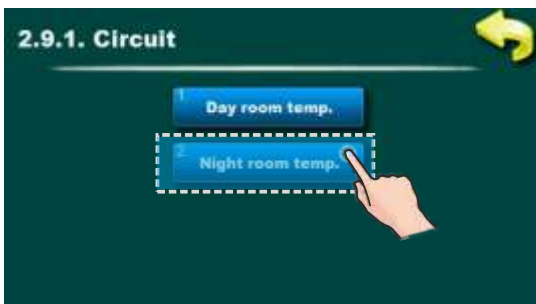

**Possible adjustment:**

Factory: 20.0°C

Option: 5.0 - 30.0°C

This sets up the first heating circuit night room temperature.

### 3.0. SCHEDULE



This option is used to set a working time of the burner, DHW tank heating, DHW recirculation pump and to change daytime and night time temperature of the first and the second heating circuit.

**NOTE:**

This manual shows the screen with the largest possible number of the basic boiler controller devices where schedule is available. An actual number of the devices with ordinal device numbers depends on chosen a selected configuration.

### 3.1. SCHEDULE - BOILER



This option is used to select a one of the three **SCHEDULE** tables you have set or to select **Schedule: OFF**

**Possible adjustment: "SCHEDULE ":**

- Factory: OFF
- Table 1, Table 2, Table 3

**NOTE:**

You can adjust three different tables according to your needs, but one table can be active at the moment only.

### 3.1.2. TABLE 1/2/3



This option is used to set "**SCHEDULE TABLES**". Each table can be set individually. You can set ON/OFF 3 times during 1 day and every day can be individually set.

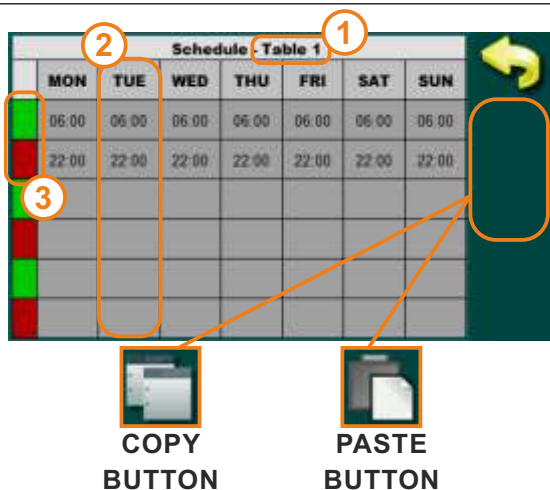

- 1 - current table you are adjusting (table 1 / table 2 / table 3)
- 2 - day of the week
- 3 - green - burner start (on)  
red - burner stop (off)

Press the box to adjust the time  
 You can adjust 3 start and stop during 1 day  
 You can copy/paste from one day to another by pressing the "day box" of the day which you want to copy, press the **"COPY"** button and press the desired "day box" and press **"PASTE"** button.

### 3.2. DHW



This option is used to select a one of the three **SCHEDULE** tables you have set or to select **Schedule: OFF**

**Setting up the table "SCHEDULE":**

- Factory: OFF
- Table 1, Table 2, Table 3

**NOTE:**

You can adjust three different tables according to your needs, but one table can be active at the moment only. Each table can be set individually. You can set 3 starts and 3 stops of an active DHW period in a day.

### 3.3. RECIRCULATION



This option is used to select a one of the three **SCHEDULE** tables you have set or to select **Schedule: OFF**

**Setting up the table "SCHEDULE":**

- Factory: OFF
- Table 1, Table 2, Table 3

**NOTE:**

You can adjust three different tables according to your needs, but one table can be active at the moment only. Each table can be set individually. You can set 3 starts and 3 stops of an active DHW recirculation period in a day.

### 3.4. SCHEDULE – 1st heating circuit



This option is used for adjusting periods when room temperature is maintained. "Day temperature"/"Night temperature" or "Table" where switching from "Day temperature" to "Night temperature" is defined.

**Possible adjustment:**

- Factory: Day temperature
- Day temperature, Night temperature, Table

**NOTE:**

It is possible to adjust one table with different settings. In the table it is possible to set the three switch to "Day temperature" and three switch to "Night temperature" in one day..

### 3.5. SCHEDULE – 2st heating circuit

This option is used for adjusting periods when room temperature is maintained. "Day temperature"/"Night temperature" or "Table" where switching from "Day temperature" to "Night temperature" is defined.

**Possible adjustment:**

- Factory: Day temperature
- Day temperature, Night temperature, Table

**NOTE:**

It is possible to adjust one table with different settings. In the table it is possible to set the three switch to "Day temperature" and three switch to "Night temperature" in one day.

## 4.0. HISTORY



This option is used to see the history of the occurred "ERRORS" and "WARNINGS"

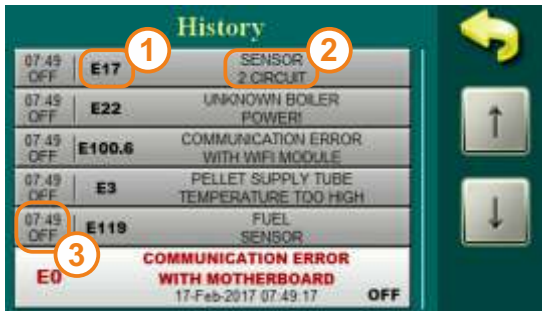

This option is used to see the history of the occurred "ERRORS".

- 1 - error code
- 2 - description of the error
- 3 - time and error of operation phase

Errors codes are marked with the letter "E".

List and the description of the errors can be found at the end of these instructions.



This option is used to see the history of the occurred "WARNINGS"

- 1 - error code
- 2 - description of the error
- 3 - time and working stage when warning occurred

Warning codes are marked with letter "W"

List and the description of the warnings can be found at the end of these instructions.

## 5. OPERATION MODE



This menu is used to set various parameters, enable/disable various additional equipment and functions, various work modes, manual test etc.... This menu is designed for end user.

**NOTE:**

some of the options in this menu are GREYED OUT (disabled) and they can't be changed.

They are only shown to see settings/values of some options.

View in this menu depend of selected options and additional equipment.

### 5.1. FORCED SHUTDOWN



This option is used to forced shut down of the burner in any working stage. Before pressing the "FORCED SHUTDOWN" you must switch off the burner on the "ON/OFF" switch and confirm "STOP" action on the main display.

**NOTE:** after "FORCED SHUTDOWN" you must open the boiler door with burner, and clean the burner grate before starting the burner again.

### 5.2. MANUAL TEST



This menu is used to check the relay outputs, the connection to the electrical parts and the operation of the electrical parts of the boiler. Pressing the Start button starts the selected component, pressing the Stop component button stops functioning.

Parts:

- **burner fan:** you can check the operation of the burner fan in 2 speed (maximum RPM and 1700 rpm) - when you turn on the test, the measured RPM is displayed on the screen. If max. RPM printed more than 3000, measurer RPM is not well positioned or is defective

- **pellet transporter:** the operation of the pellet transporter can be checked

- **el. Heater + burner fan:** the burner heater function (igniter) can be checked - to protect the burner el. heater, the burner fan is automatically switched on when the heater is switched on

- **pump P1 / DHW / RECIRCULATION:** the operation of all connected pumps can be checked

- **1.circuit / 2. circuit:** it is possible to check the operation of all mixing heating circuit elements (pumps, opening / closing of actuator)

- **mixing valve (with actuator (backflow protection))-** it is possible to check the operation of the mixing valve actuator (backflow protection)

- when in the manual test (mixing valve) is pushed button "START" (close MV!) valve must close the water flow from the heating installation into boiler and open the bypass (case1 and case 3 or mirror image if the mixing valve is installed on the left side of the boiler).

- when in the manual test (mixing valve) is pushed button "START" (open MV!) valve must open the water flow from the heating installation into boiler and close the bypass (case2 and case 4 or mirror image if the mixing valve is installed on the left side of the boiler).

- **additional equipment:** menu for manual test of the installed additional equipment

**NOTE:** The display in this menu and the "ADDITIONAL EQUIPMENT" menu depends on the configuration selected and the installed additional equipment.

**Case 1. 3-way mixing valve with actuator is 100% closed.**

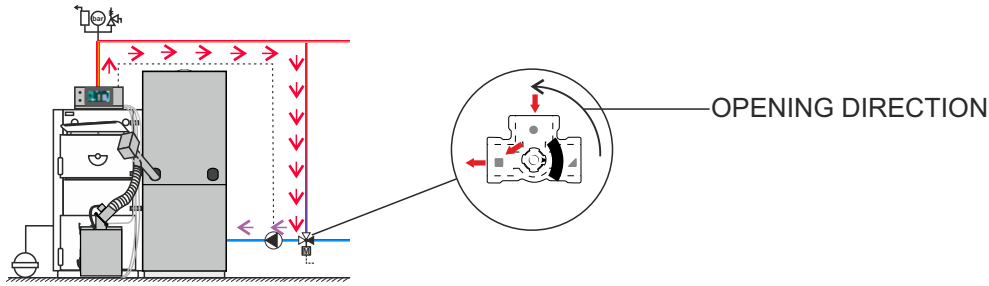

**Case 2. 3-way mixing valve with actuator is 100% open.**

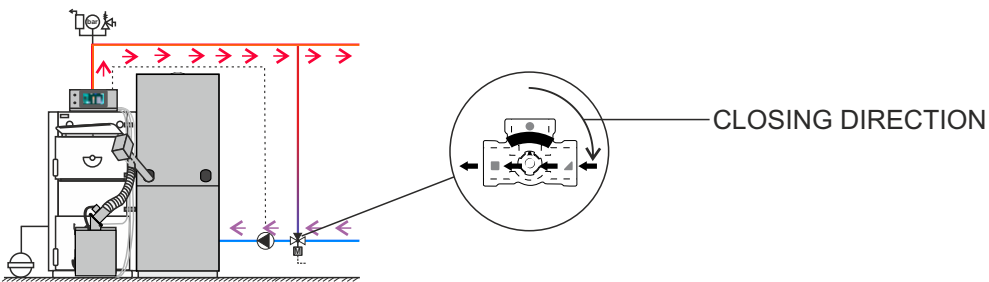

**Case 3. 4-way mixing valve with actuator is 100% closed.**

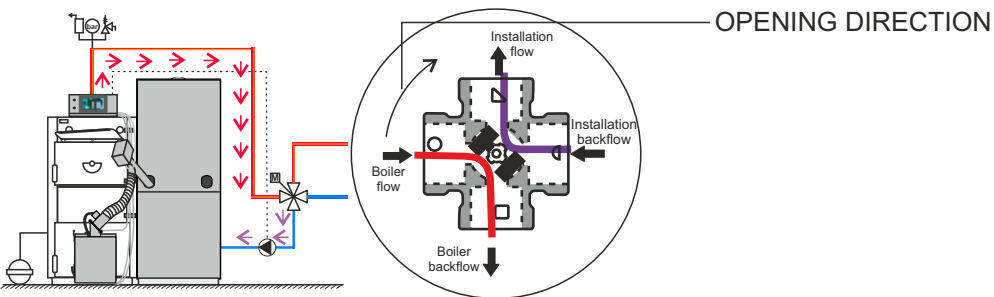

**Case 4. 4-way mixing valve with actuator is 100% open**

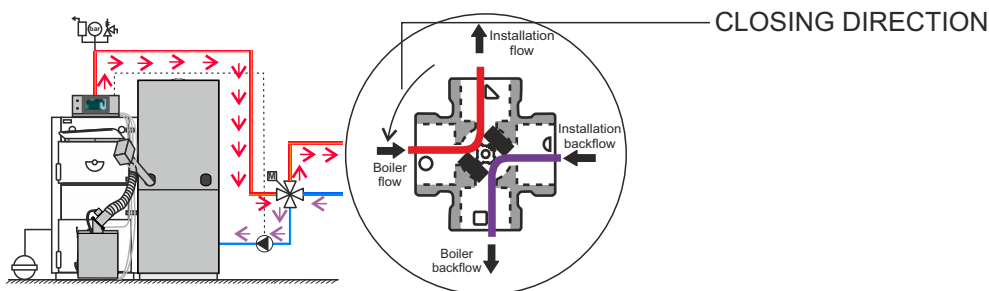

### 5.3. PELLETT TRANSPORTER



**NOTE:**

If the transporter is empty, it must be filled before the burner is started.

**Filling feeder screw:**

This option is used to initially filling of the transporter. It can also be used if the transporter is emptied. We recommend that you start the procedure and wait for the process to complete to make sure the transporter is full (20 min.). Before starting this option, disconnect the plastic flexible tube from the burner and place the bucket / bag underneath. After finishing the process, empty the pellet / bucket bag into the pellet tank and connect the plastic flexible tube back to the burner.

**Filling at start check:**

This option is used to control the initially filling of the burner. By pressing the "START" key the transporter will start working and continue continuously until the set time has elapsed (the counter starts to count down). The specified time is set in the Initial Charge parameter in the "INSTALLATION" menu. After the transporter has stopped working it is necessary to open the burner door and check if the pellets are covered. El. heater for correct ignition (open the lower door and close them after checking (microswitch)) - follow the instructions on the screen. After completion of the control and eventual correction of the initial charge time (+ 10%), the control automatically records the done change, the boiler starts automatically without initial charge! (so you do not need to clean the pellet grate manually). If you do not want to start automatically after the control, the "5. Operation mode-> 5.1.Forced Shutdown" may turn off the burner, but after that you must clean the burner grate.

**Possible Reasons for Correction:**

If the pellets are not covered the el. heater, the pellet transporter may be either insufficiently filled or the initial filling time should be extended (in steps of 10 seconds).

### 5.4. WEIGHING CHECK



This option is used to check pellet delivery amount.

You can set the transporter working time (1) after which you want to weight the pellet.

On screen is displayed factory amount and last measuring which can be done only by authorized serviceman (if has been done, if not factory and last weighing is the same).

In order to weigh more precisely weighing must be repeated at least 3 times.

## 5.5. SAVE/LOAD



This option is used to save parameters, load / load service parameters and delete saved parameters.

SAVE - save current settings

LOAD - load saved setting

LOAD SERVICE - load setting authorized serviceman saved

DELETE - delete saved settings

You can save multiple setting under different names and you can load and delete saved setting.

## 5.6. STANDARD EQUIPMENT



This option is used for view (adjusting) standard equipment of Cm Pelet-set\_Touch.

Options:

- **sensors** - it is only possible to view the type of sensor (PT1000 – factory or NTC 5K)
- **photocell** - it is only possible to preview the photocell settings
- **1st circuit / 2nd circuit** - the user settings of the heating circuits can be adjusted
- **DHW**- DHW can be set (on / off) and if recirculation is switch on can be set also "Recirculation operation time" and "Recirculation pause".
- **mixing valve** - (with actuator (backflow protection)) it is possible to check the settings: "Valve time" (opening time of 0-100%, all configuration with mixing valve), "Min. opening" (after the temperature of the backflow exceeds 60 ° C the mixing valve opens to a set percentage, if the temperature of the recovery falls again below 60 ° C the mixing valve closes, this is only possible for the "H" configurations that actively activate the mixing valve).

**NOTE:**

- some of the options in this menu are DISABLED and could not be changed. It only serves to view the set value. The display in this menu depends on the selected configuration (XYZ).

### 5.6.1. SENSORS



This option is used for view the selected sensors type (NTC 5K or PT1000).

**Factory: PT1000**

Options: Pt1000 / NTC 5K

### 5.6.2. PHOTOCCELL



This option is used to view the selected photocell parameters.

### 5.6.3/5.6.4. 1. CIRCUIT / 2. CIRCUIT

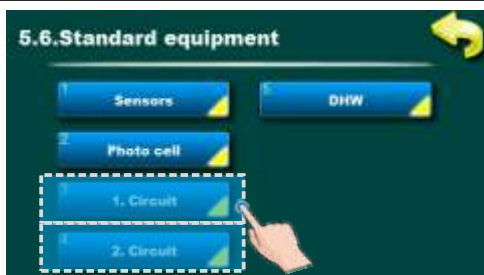





This option is used for adjusting the mixing heating circuits.

**NOTE:**

some parameters are shown in "OPERATION" menu but can't be changed. They can be changed only in "INSTALLATION" menu which is under PIN (only for authorized serviceman).

**5.6.3.1 - 5.6.4.2 1. CIRCUIT / 2. CIRCUIT**

It's possible to view all enabled mixing heating circuits (set temperatures, measured temperatures, heating type, working of the pumps etc...). To enter this view press  /  button and then .

If there are more than 2 mixing heating circuits enabled you can switch view between them with   buttons.

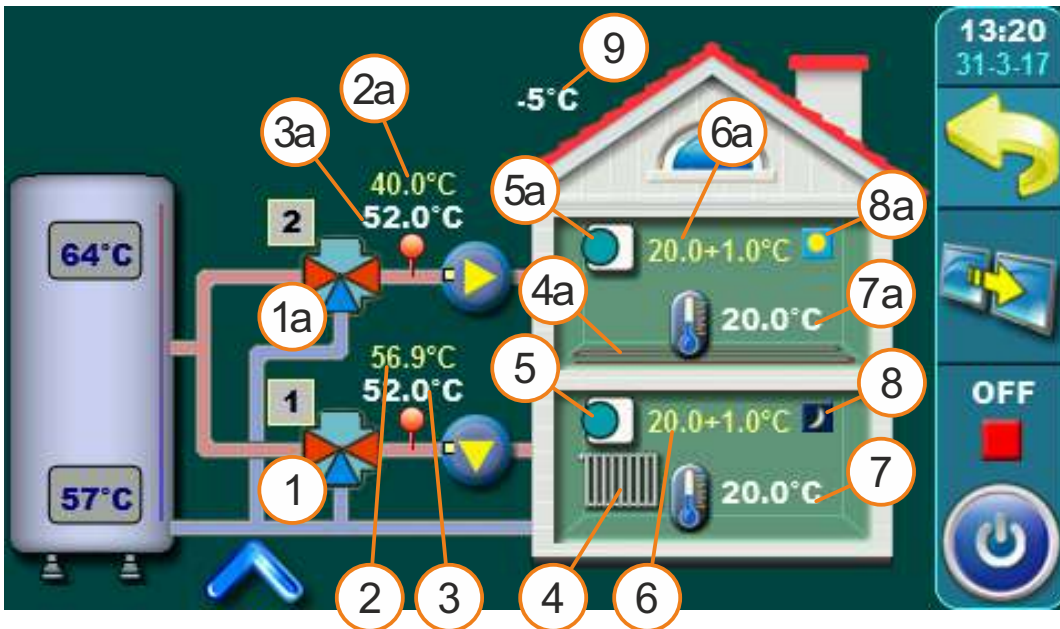
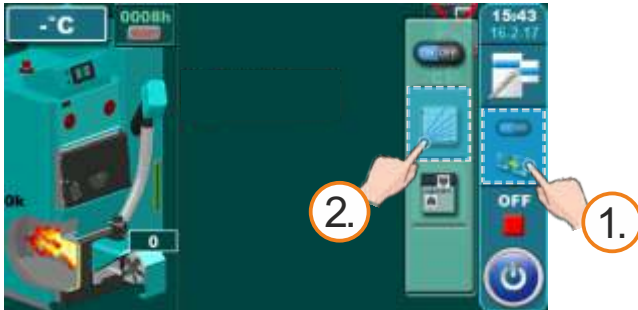

This schematic view is only possible to view, it is not possible to turn on / off / adjust individual elements.

General:

Specific elements can be individually adjusted and displayed for each heating circuit.

For example: Turn on / off the heating circuit, turn on / off the room corrector, select the type of heating circuit for each circuit (radiator / floor), select the operation mode (daily / night).

- |   |  |
|---|--|
| 1 - Mixing valve (1.circuit)  | 6 - The desired temperature + deviation by room corrector (1.circuit)                              |
| 2 - The calculated flow temperature (1.circuit)                         | 7 - Current measured room temperature (shown only if the room corrector is turned on) in 1.circuit |
| 3 - Current measured flow temperature (1.circuit)                       | 8 - Mode (1.circuit) (day / night)   |
| 4 - Heating type on 1. circuit (radiators or floor heating)             | 9 - Outer temperature (outer sensor)   |
| 5 - Room corrector „CSK“ on 1. circuit (if turned off, icon disappears) |  |



**Elements 1a - 8a have the same meaning as elements 1 to 8 (described above) refer only to the 2nd heating circuit or or any heating mixing circuit involved with respect to the number of circuits included.**

**SETTING PARAMETERS FOR EACH HEATING CIRCUIT**

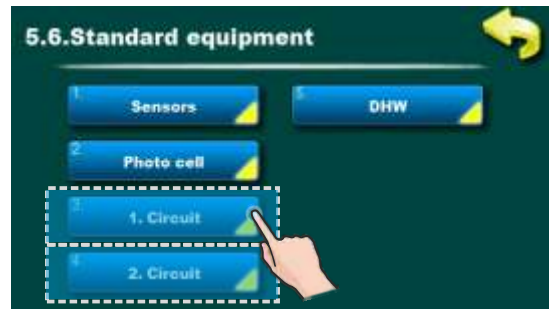

Regulation can control up to two mixing heating circuits. They must be enabled and set under "INSTALLATION" menu. To make adjustment of each circuits go to the "OPERATION" menu then "STANDARD EQUIPMENT" menu.

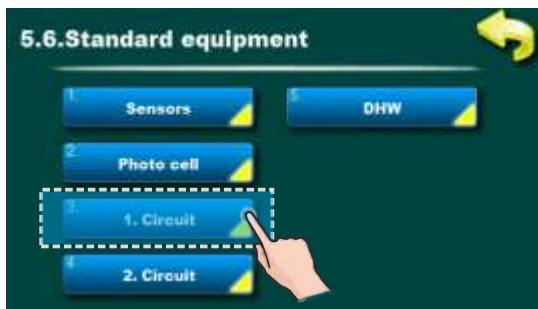

**Possible selection:**

Factory: **ON**

Option: ON, OFF

By using this option you can enable/disable heating circuits.

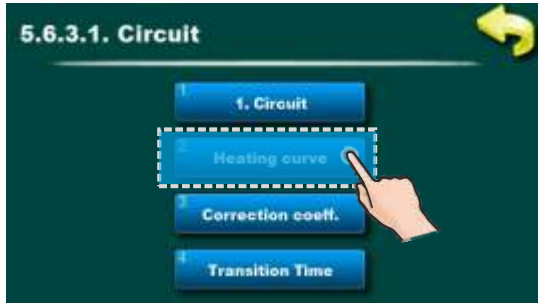

**Possible selection:**

Factory: **1.0**

Option: 0.1 - 4.0

By using this option you can set heating curve value.

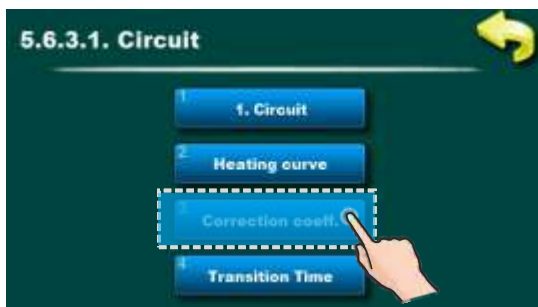

**Possible selection:**

Factory: **1.0**

Option: 0,1 - 5,0

By using this option you can set correction value.

## 5.7. ADDITIONAL EQUIPMENT



This option is used to view the setting / setting of additional equipment that is not in the basic delivery (for most of the equipment the setting lowers on / off and detailed adjustment is performed by the authorized service person).

Options:

- **Air cleaning** - turn on/off air cleaning
- **Flap** - turn on/off burner flap (only for preview)
- **CM2K** - turn on/off CM2K (only for preview)
- **External control** - turn on/off external control (start) (only for preview)
- **Cascade** - turn on/off the cascade and setting up certain options
- **CAL** - turn on/off alarm alert and setting up certain options
- **CM-GSM** - turn on/off CM-GSM module
- **Internet supervision** - turn on/off internet supervision and setting up certain options
- **CMSR100** - turn on/off fuel level sensor and reserve time (only for preview)
- **Suction system** - turn on/off suction system and setting up certain options
- **CSK-Tocuh** - turn on/off CSK-Touch and setting up certain options



**NOTE:**

additional equipment must be enabled under "**INSTALLATION**" menu (PIN required) and only then is shown in this menu.

Some of the items shown here can be adjusted only under "**INSTALLATION**" menu and can be changed only by authorized serviceman.

### 5.7.1. INTERNET SUPERVISION

This option is used to connect regulation to the internet trough Cm Wifi-box via WiFi network. Cm WiFi-box is additional equipment and is not part of standard delivery.

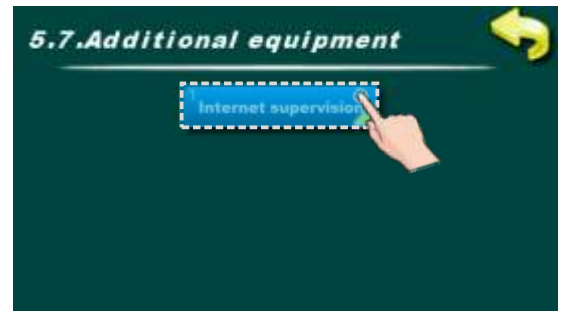

This option is used to enable/disable Cm WiFi-box and set its parameters.

**NOTE: view in this menu depends of enabled additional equipment.**



Internet supervision options:

- **Factory: "Sup. + control"**  
- options: "OFF" / "Supervision" / «Sup.+control»

WiFi network name - this option is used to enter the name of the WiFi network you want to connect

WiFi password - this option is used to enter password of the WiFi network you want to connect

Time sync. - this option is used to synchronise time between web portal and boiler

Time zone - this option is used to set the time zone if boiler time zone is different from web portal time zone

Connection reset - this option is used to reset the connection between Cm WiFi-box and boiler

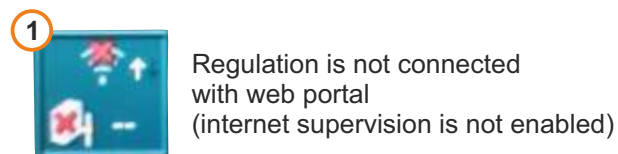
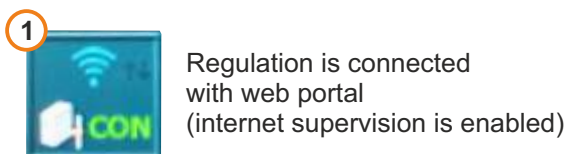
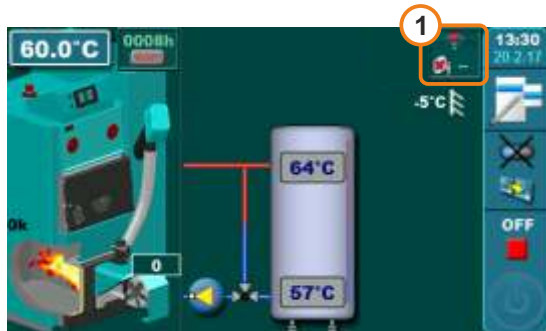

### IMPORTANT NOTES



**CM WiFi-box requires active DHCP server of Access Point (e.g. router) because manual setting of network parameters is not possible. For more informations contact administrator of your local network.**



**For detailed configuration of the Cm WiFi-box please refer to the Cm WiFi-box manual received with the Cm WiFi box.**

**5.7.2. CSK-TOUCH (ADDITIONAL EQUIPMENT) - only for authorized service technicians - possible from the software version "v1.26d"**

The CSK-Touch digital room corrector enables room temperature control and the heating circuit is switched ON and OFF according to the set room temperature and schedules. In addition to measuring and correcting the room temperature, this room corrector allows you to turn the boiler on and off, set the min. accumulation (buffer) tank temperatures and boiler and domestic hot water (DHW) temperatures if any, and setting of schedules for the heating circuit.

**CSK-Touch can be connected directly to Pelet-set Touch boilers only via the CM WiFi box or via a router using the CM WiFi box. Wire connection directly to the boiler is not possible.**

The digital room corrector can be connected to Pelet-set Touch via a CM2K module (if any). The connection to CM2K can be: wired (2 wires), wireless via a CM WiFi box or via a home router. For more details on how to connect the CSK-Touch, see "Technical instructions for installation, use and maintenance CSKTouch digital room corrector".



To configure the CSK-Touch corrector, it is necessary to configure the heating mixing circuits (on the boiler and/or CM2K module), which must be done by an authorized service technician (by entering the PIN in the Installation menu.)

In menu 11, when configuring an individual heating circuit in the "Corrector" menu, it is necessary to select "CSK-Touch" and select its unique address in the "Addr. dig. corrector" menu.

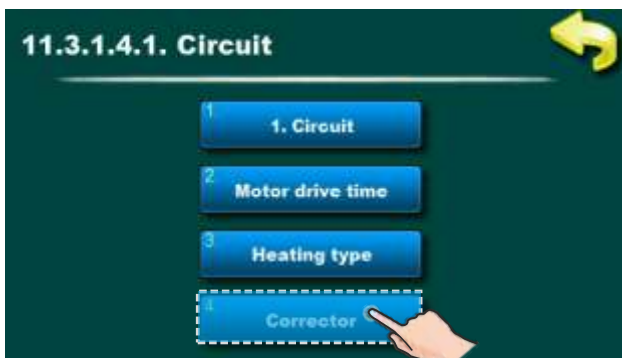

Enable the corrector in the heating circuit



Select the type of corrector used



Select a unique address dig. corrector

## CSK-Touch (additional equipment)



After configuring the heating circuits on the CM2K module, it is necessary to open the INFO menu in the CSK-Touch menu and copy/remember the CSK-Touch WiFi ID (1) and Address Codes (2) (depending on the number of installed correctors) that need to be entered in each CSK -Touch when configuring it.



CSK Touch WiFi ID : 335E6F5E (1)

Addr.	Addr. code	Conn. type	Status	Signal	Packets
1	Y A o o	Wired	✓	-	209
2	Wm X X	Router	✓	-42dB	153
3	O i d d	Addr. 1	✓	-38dB	427
4	0 B G G	-	✗	-	0
5	9 1 9 9	-	✗	-	0
6	Wb Y Y	-	✗	-	0
7	2 z WW	-	✗	-	0
8	q K O O	-	✗	-	0

(2)

According to the user's wishes, certain actions that are factory-enabled for all digital room correctors can be disabled on an individual digital room corrector.



For each corrector can be enabled / disabled:

- CSK-Touch view configuration
- Boiler temperature
- Boiler control
- Boiler Schedule
- Circuit 1...Circuit 8.



### Note:

Circuit 1 (1) and Circuit 2 (2) are boiler circuits (direct connection to the boiler - basic equipment, but a CM-WiFi box is required)  
 Circuit 1+ (3) ... Circuit 6+ (8) are CM2K module circuits (additional equipment).

For details see instructions: **Technical instructions** for installation, use and maintenance **CSK-Touch** digital room corrector

### 5.8.1. FREEZE GUARD



**Possible selection:**

**Factory:** OFF

Options: OFF, ON

While Freeze guard option is enabled, controller monitors minimum set temperature of each sensor in boiler and equipment attached to controller and, in case that Toutside option is enabled, controller also monitors minimum outside temperature. If temperature drops below set value, controller starts pumps and the boiler if needed.

While Freeze guard option is enabled and particular pump are selected in submenu Option, if particular system components are disabled (ie. DHW tank...), those components are display in grey on the Main screen. The pumps that supply those disabled components will be started due to Freeze guard option. The pumps started due to Freeze guard option have no additional marking in their symbols.

In case the Freeze guard option is enabled, but a heating circuit is disabled, a number by the heating circuit is crossed and the heating circuit is started due to Freez guard option.

### 5.8.2. TOUTSIDE

While Freeze guard option is enabled, controller monitors minimum set temperature of each sensor connected to the controller and the minimum set outside temperature. While Toutside is disabled, the Freeze guard option will monitor minimum set temperature of the boiler and equipment only.

Enabling and disabling of this option can be provide under INSTALLER (PIN), a customer has just possibility to view this option.

### 5.8.3. OPTION

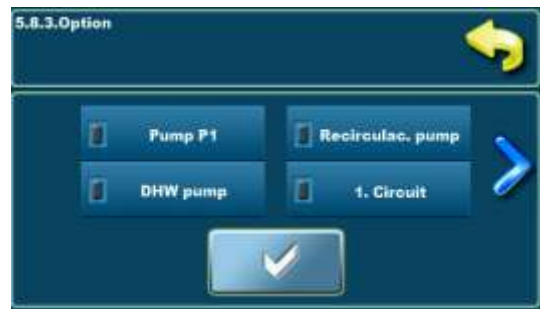

If both Freeze guard and Toutisde options are enabled, a customer has an opportunity to enable particular pump (each pump must be selected separately) while minimum outside temperature drops below set value. In menu are displayed all active pumps that can be selected. If there is a defect on outside temperatruue sensor or if it is disabled, but Toutside option is enabled, the situation will be considered as fulfilled outside temperature condition and the pumps will be enabled to work.

### 5.8.4. TEMPERATURE

Freeze guard (set temperatures preview):

**Tsensor\_min** - minimum temperature of an each sensor to start the Freeze guard

**dTsensor\_min** - minimum temperature difference of an each sensor

**Toutside\_min** - minimum outside temperature to star the Freeze guard

## 5.9. WORK MODE



This option enables to set working mode

**Possible selection:**

- **Factory: Heating+DHW** (unless the basic equipment doesn't have any heating circuit)
- Options: Heating+DHW, AUTO DHW<>Heat. + DHW, DHW

**Heating+DHW** - this mode is possible if there are both heating circuits and DHW, the heating and DHW tank are controlled according to set conditions.

**AUTO DHW<>Heat.+DHW** - This mode is possible if there are both heating circuits and DHW, the controller changes Heating+DHW and DHW mode according to set conditions (outside temperature) and it automatically adjusts the system to the selected working mode and to the selected working mode conditions.

**DHW** - this mode is possible if there are both heating circuits and DHW, but DHW mode is manually or automatically selected, or there are no heating circuits, just DHW.

**Note:**

If DHW is used in configurations X7Y and X8Y over CM2K module, in DHW mode DHW over CM2K is disabled. If a customer wants to use DHW over CM2K, all heating circuits must be manually disabled in CM2K and Heating+DHW mode must be selected.

### 5.10.1. EXTINGUISHING FOR CLEANING

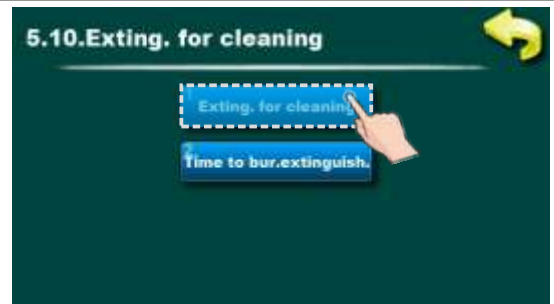

This option is used for enabling and disabling Extinguishing for cleaning option. If this option is enabled the burner automatically starts extinguishing phase for grate cleaning / blowing an ash off the grate after continuous working time in the set time "Time to burner extinguishing" (if burner extinguishing conditions are not fulfilled, the burner is automatically started again after extinguishing phase).

**Note:**

Depending on a pellet quality, that are used, it is recommended to occasionally switch the burner off and clean the burner grate with fan (or air cleaning – additional equipment).

**Possible selection:**

- **Factory: ON**
- Options: ON, OFF

### 5.10.2. TIME TO BURNER EXTINGUISHING

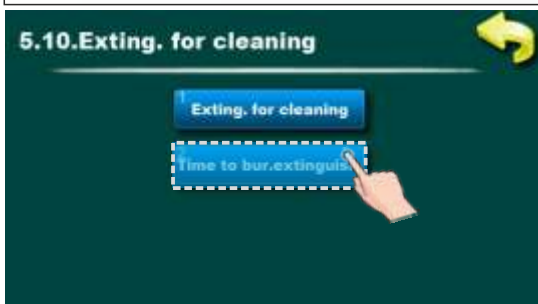

This option is used to set time for burner shut down. In case of continuous burner working for this time, burner will shut down (in this process it will clean the grate, with burner fan or air cleaning if it's installed). After burner shutdown process, burner will start again and this counter will be reset. Also at every shut down, this counter is reset.

**Possible selection:**

- **Factory: 180 min (OFF)**

- Options: 45 - 360 min

### 5.11. MODULATION



This option is used to show set parameters of modulation.

**Possible selection (parameters can be changed in INSTALATION menu (under PIN) only) :**

- **Factory: ON**

- Options: ON / OFF

If the option "MODULATION" is enabled it can be see set parameters of the modulation.

**Modulation beginning** - set how many °C below set boiler temp. modulation will start (options: -4°C, -3°C, -2°C, -1°C)

**Modulation percentage** - set in how many steps (percentages of power) modulation will work (options depends of the set burner power)

**Burner power:**

power **90, 35 kW** have **4 steps** of modulation (80/65/50/30%)

power **70, 50, 30, 25 kW** have **3 steps** of modulation (80/60/50%)

power **60, 40, 20, 14 kW** have **2 steps** of modulation (75/50%)



### 6. DISPLAY



This option is used to set display/sound parameters.

Options:

- **Screensaver** - a time period after which screensaver shows for protecting the screen due to displaying the same image for a long time. By touching the screen Screensaver disappears and the next screensaver time period countdown starts after the last touch. If there is an "Error/Warning" Screensaver disappears and the next screensaver time period countdown starts after an error/warning is confirmed to be seen by a customer or after the last touch.

- **Language selection** - this menu enables or disables displaying of the language selection screen as an initial screen after the controller is switched on. If 'OFF' is selected, the controller will be switched on in the pre-set language and after a certain period of time, 'Initial message time', the main screen will appear. During the first commissioning, an authorized serviceman will select preferred language and disable Language selection option to allow the controller to automatically start after electricity gets back. If Language selection is not disabled, after electricity gets back, the controller will wait a customer to select the preferred language and then continue to work.

- **Initial message time** - time period setup after controller is switched on in case the Language selection option is disabled (after that time main screen will be displayed). Time is counted if Language selection option is disabled only.

## Display, info, correction

- **Show timers** - this option allows a customer to have the timer of each working phase displayed in the main screen. This option makes it easier to monitor working phases of the burner and other components.

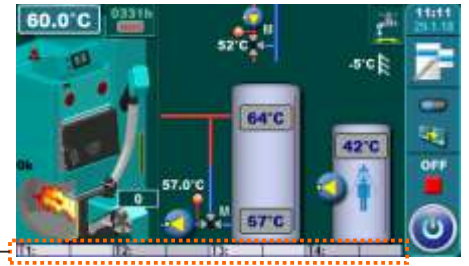

- **Date & Time** - current time and date adjusting. If those parameters are not correct, the scheduled times will not work properly. If time gets reset to 00:00 and date is 1.1.2000. it is necessary to replace the battery on the controller display (CR1220).

- **Sound volume** - to set one of the 3 volume levels or turn the sound off.

- **Sound type** - to select one of the 10 types of the sound.

## 7. INFO



This option is used to see various informations regarding regulation and burner.

Options:

- **Statistics** - here are shown working times of various boiler elements (burner working time / burner working time in DHW mode / burner working time in Freeze protection mode / number of burner starts / burner fan working time / igniter work time / number of igniter starts / transporter work time / pump P1 work time)
- **Software version** - it can be see burner power (14kW, 20-35kW, 40/50kW ili 90kW), regulation software version and WiFi ID number (if Cm WiFi-box is installed)
- **Selected configuration** - it can be see currently selected configuration
- **Current file** - it can be see which saved file is currently in use
- **Select burner power** - it can be see currently set burner power (it can be selected by an authorized serviceman only – under PIN)

## 9. CORRECTION



This option is used make correction of pellet delivery. You can decrease delivery by 3 steps. Steps are factory configured. Icon changes according the set step.

"0" - no correction

"1" -> screw feeder supply reduction by 10%

"2" -> screw feeder supply reduction by 20%

"3" -> screw feeder supply reduction by 30%

It is recommended that the customer uses this option if there is, because of the type or quality of pellets, larger amount of sediment left on the burner grate after burning cycle (with regular grate cleaning) or if the customer, during weighing (article 5.4. Weighing check), finds out that screw feeder delivers more pellets than the value entered in "Weighing check" table under "Last weighing".

## 10. CHIMNEY SWEEPER



This option is used to enable and set "**CHIMNEY SWEEPER MODE**"

Options:

- **Chimney sweeper** - it can be enabled or disabled "Chimney Sweeper" mode
- **Power** - it can be set burner power for "Chimney Sweeper" mode
- **Minimum boiler temperature** - it can be set the minimum boiler temperature for "CS" mode

**"Chimney sweeper MODE"** - this mode enables you make flue gas measurement on selected burner power and set minimum boiler temperature. In this mode boiler will be excluded from cascade, external control etc. and work only according boiler temperature. Also in this mode modulation temperatures are lower so burner will modulate later, to enable longer measurement on set power.

## 11. INSTALLATION



This menu is used only by authorized servicemen.  
For entry in "INSTALLATION" menu is necessary to input PIN.

### 12. BURNER WORKING STAGES



Burner working stage

- OFF** - burner doesn't work (OFF - burner will not start)
- A0** - burner start - only burner fan is working
- A1** - start of start up safety time measuring, start of igniter working
- A2** - start of transporter working (initial filling)
- A3** - end of initial filling (transporter stops), waiting for the flame (in case flame doesn't appear in set time error E2 will appear, ignition fail)
- A4** - start of time measuring until entering into the transition stages and additional working time measuring of electric igniter; a flame loss monitoring is started and if there is no flame for more than 4 minutes, the controller gets the burner working mode back to stage A3 (electric igniter is working)
- A5** - end of additional igniter working, start of time measuring to enter transition stage PP1
- PP1** - transition stage 1
- PP2** - transition stage 2
- PP3\*** - transition stage 3\*
- PP4\*** - transition stage 4\*
- PP5\*** - transition stage 5\*
- A6** - the burner working mode before reaching the nominal power (fan spins at higher rate than the set value); if there is a flame loss for longer than 15 seconds, the controller gets the burner working mode back to stage A3 (electric igniter is working)
- P** - (factory selected) burner nominal power
- PX\*\*\*** - burner nominal power (P6, P5, P4, P3, P2 - depends of the burner set power)
- M4\*\*** - modulation stage 4
- M3\*\*** - modulation stage 3
- M2\*\*** - modulation stage 2
- M1\*\*** - modulation stage 1
- PFON230** - power failure and power return stage - (burner tries to establish normal work after power supply failure and return of the power supply)
  - F1** - (factory selected for CPPL 60/70/90 kW) overload phase of the pellet inlet pipe overload sensor
  - S7** - (factory selected) the first step in the burner extinguishing phase
    - the screw feeder doesn't work, the fan works as in previous phase (if it spins within factory / authorized serviceman min / max value), duration: (factory setting) 7 minutes
  - S7-1** - (factory OFF, this option can be chosen instead option S7 by an authorized serviceman) - the first step in the burner extinguishing phase
    - the screw feeder doesn't work, the fan works as in previous phase (if it spins within factory / authorized serviceman min / max value), duration time is until flame loss is spotted or up to (factory setting) 5 minutes
  - S7-2** - the second step in the burner extinguishing phase
    - the fan spins at maximum rate, duration: (factory setting) 2 minutes
  - S7-3** - STANDBY (phase) – the burner waits for some of the start conditions (temperature difference in the boiler, hydraulic crossover temperature, buffer tank temperature, demand in heating circuit(s), DHW tank heating demand...)
- \* - transition phase number depends on selected / installed burner heating power
- \*\* - (factory selected) modulation number depends on selected / installed burner power and (on) selected modulation level
- \*\*\* - (disabled by default, an option that can be selected instead of modulation option by an authorized serviceman) the nominal (the maximum rated) heating power depends on selected / installed burner heating power

### 13. HEATING CONFIGURATION (markings on the display)

CONFIGURATION MARKINGS IN GENERAL: XYZ

**Marking description on the individual positions:**

**X \_ \_** - the mark on the first position indicates the mode of the boiler connection on the heating installation (return line safety):

- A** - marks the boiler connection with the ACCUMULATION TANK via the 3 way thermostatic valve (return line safety 60°C)
- B** - marks the boiler connection with the ACCUMULATION TANK via the 3 way valve with actuator (return line safety 60°C)
- C** - marks the boiler connection with the HYDRAULIC CROSSOVER via the 3 way thermostatic valve (return line safety 60°C)
- D** - marks the boiler connection with the HYDRAULIC CROSSOVER via the 3 way valve with actuator (return line safety)
- E** - marks the boiler connection with the HYDRAULIC CROSSOVER + SENSOR via the 3 way thermostatic valve (return line safety 60°C)
- F** - marks the boiler connection with the HYDRAULIC CROSSOVER + SENSOR via the 3 way valve with actuator (return line safety)
- H** - marks the boiler connection with the 4 WAY VALVE WITH ACTUATOR (return line safety)
- I** - marks the boiler connection with the ACCUMULATION TANK via the 4 way valve with actuator (return line safety)
- J** - marks the boiler connection with the HYDRAULIC CROSSOVER via the 4 way valve with actuator (return line safety)
- K** - marks the boiler connection with the HYDRAULIC CROSSOVER + SENSOR via the 4 way valve with actuator (return line safety)

**\_ Y \_** - the mark on the second position indicates if the basic boiler controller steers the production of DHW and recirculation of the DHW and in which form ( it is not taken into account one or more CM2K – modules for two heating circuits / DHW ) :

- 0** - there is no DHW and no recirculation of DHW
- 1** - a DHW tank exists beyond the boiler
- 2** - a DHW tank exists beyond the boiler and the recirculation of DHW
- 7** - a DHW tank is embedded in the boiler
- 8** - a DHW tank is embedded in the boiler and the recirculation of DHW exists

**\_ \_ Z** - the mark on the third position indicates if basic regulation steers the central heating circuits, if it steers describes the type and number of circuits (does not consider one or more CM2K modules for two heating circuits / DHW):

- 0** - boiler regulation does not steer central heating circuits with mixing valves, but with additional selection it can be operated with one or two central heating circuits
- 1** - the boiler regulation steer with one central heating circuit with the mixing valve
- 2** - the boiler regulation steer with two central heating circuit with the mixing valve

**Several examples of selected configurations (to help you understand the above description)**

**Example 1:**

**Configuration A21** - boiler connected with ACCUMULATION TANK via a 3-way thermostatic valve (60 °C return flow protection), DHW tank and DHW recirculation and single central heating circuit steer with mixing valve

**Example 2:**

**Configuration F01** -boiler connected with HYDRAULIC CROSSOVER + SENSOR via a 3-way valve with motor (backflow protection), and single central heating circuit control with mixing valve.

**Example 3:**

**Configuration H00** - boiler connected with 4-WAY MIXING VALVE WITH ACTUATOR (backflow protection) and there is a possibility of controlling one or two direct central heating circuits (if one or more CM2K modules with two heating circuits / DHW are not installed)

## Heating configuration (markings on the display)

---

### Example 4:

**Configuration H10** - boiler connected with 4-WAY MIXING VALVE WITH ACTUATOR (backflow protection), DHW tank and there is a possibility of controlling one or two direct central heating circuits (if one or more CM2K modules with two heating circuits / DHW are not installed).

### Example 5:

**Configuration H20** - boiler connected with 4-WAY MIXING VALVE WITH ACTUATOR (backflow protection), DHW tank with DHW recirculation and there is a possibility of controlling one or two direct central heating circuits (if one or more CM2K modules are not installed for two heating circuits / DHW).

### Example 6:

**Configuration H70** - boiler connected with 4-WAY MIXING VALVE WITH ACTUATOR (backflow protection), DHW tank installed in the boiler and there is a possibility of controlling one or two direct central heating circuits (if one or more CM2K modules with two heating circuits are not installed / DHW).

### Example 7:

**Configuration H80** - boiler connected with 4-WAY MIXING VALVE WITH ACTUATOR (backflow protection), DHW tank installed in the boiler, controlled and recirculated DHW and there is a possibility of controlling one or two direct central heating circuits (if no one or more CM2K modules with two heating circuits are installed / DHW).

### Example 8:

**Configuration H01** - boiler connected with 4-WAY MIXING VALVE WITH ACTUATOR (backflow protection) and steers one central heating circuit with a motor mixing valve (there is no control of one or two direct central heating circuits).

### Example 9:

**Configuration J71** - boiler connected with HYDRAULIC CROSSOVER via 4-way mixing valve with actuator (backflow protection), DHW tank built into the boiler and steer one central heating circuit with a mixing valve with actuator.

### Remark:

**Only configuration of H00, H10, H20, H70, H80 can be defined for directing one or two direct heating circuits with or without a pump, room corrector or room thermostat only in the absence of one or more CM2K modules for two circuits heating / DHW.**

The "CONFIGURATIONS" designations indicate only the heating and DHW circuits from the basic boiler equipment, they do not include the built-in heating / DHW circuits through the installation of additional equipment - additional CM2K heating controllers or some others. Viewing the selected configuration is possible by entering the MAIN MENU in "7. Info" / "7.3 Selected configuration".

13.1. CONFIGURATION A-0-0

EKO-CK P



**Temperatures:** Tboiler: 80°C (80-90°C)  
 dTboiler: 10°C (5-15°C)  
 Tbuf: 80°C (70-80°C)  
 dTbuf: 10°C (5-30°C)  
 dTbuf-off: 5°C (3-50°C)

13.2. CONFIGURATION A-0-1

EKO-CK P

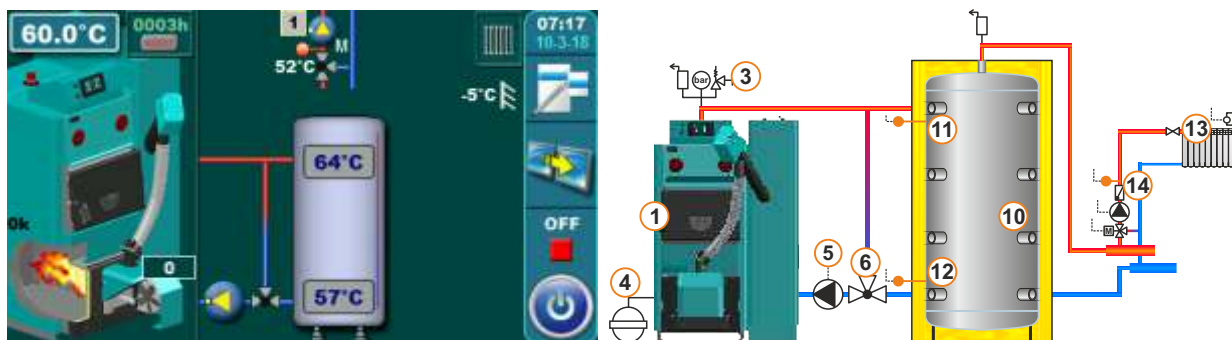

**Temperatures:** Tboiler: 80°C (80-90°C)  
 dTboiler: 10°C (5-15°C)  
 Tbuf: 80°C (70-80°C)  
 dTbuf: 10°C (5-30°C)  
 dTbuf-off: 5°C (3-50°C)

Tbuf min.: 20°C (5-85°C)

1. Circuit:  
 Const. temp. day: 60°C (20-90°C)  
 Const. temp. night: 60°C (20-90°C)  
 Day room temp.: 20°C (5-30°C)  
 Night room temp.: 20°C (5-30°C)

13.3. CONFIGURATION A-0-2

EKO-CK P

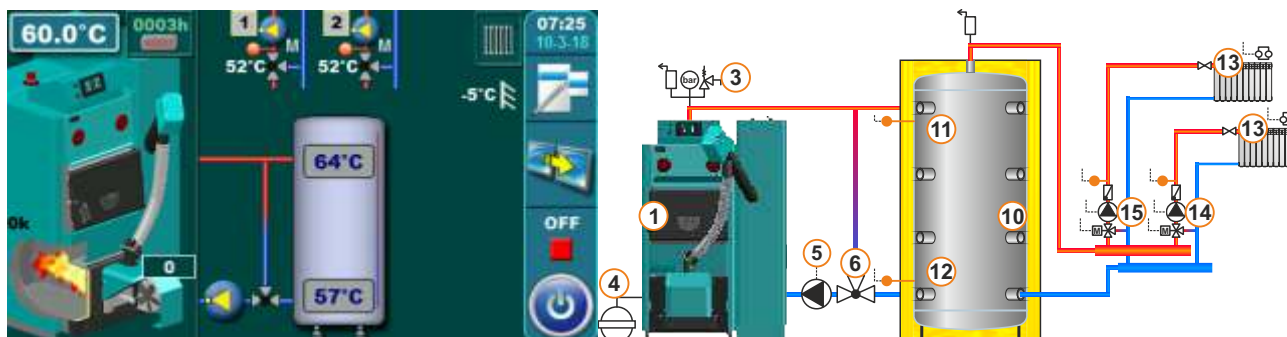

**Temperatures:** Tboiler: 80°C (80-90°C)  
 dTboiler: 10°C (5-15°C)  
 Tbuf: 80°C (70-80°C)  
 dTbuf: 10°C (5-30°C)  
 dTbuf-off: 5°C (3-50°C)

Tbuf min.: 20°C (5-85°C)

1. Circuit, 2. Circuit:  
 Const. temp. day: 60°C (20-90°C)  
 Const. temp. night: 60°C (20-90°C)  
 Day room temp.: 20°C (5-30°C)  
 Night room temp.: 20°C (5-30°C)

13.4. CONFIGURATION A-1-0

EKO-CK P

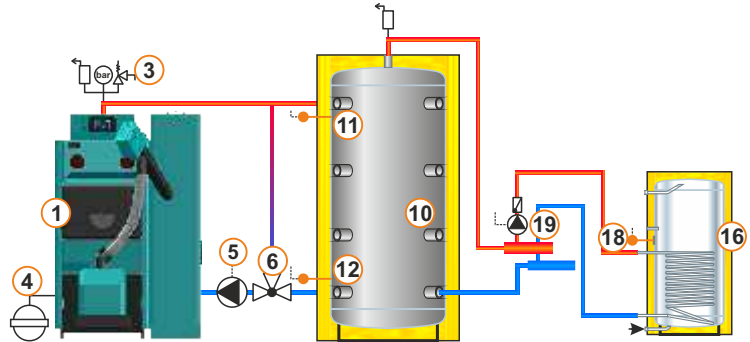
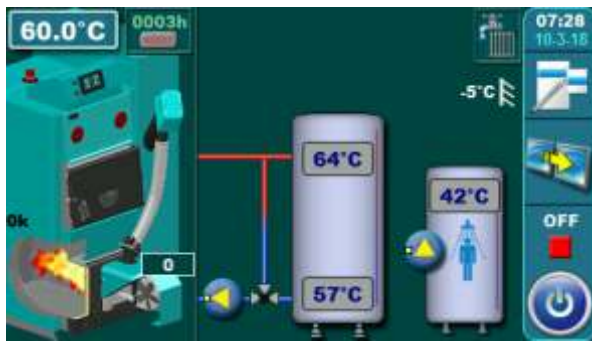

**Temperatures:** Tboiler: 80°C (80-90°C)  
dTboiler: 10°C (5-15°C)  
Tbuf: 80°C (70-80°C)  
dTbuf: 10°C (5-30°C)  
dTbuf-off: 5°C (3-50°C)

Tdhw: 50°C (10-70°C)  
dTdhw: 5°C (5-50°C)  
Tbuf min.: 20°C (5-85°C)

13.5. CONFIGURATION A-1-1

EKO-CK P

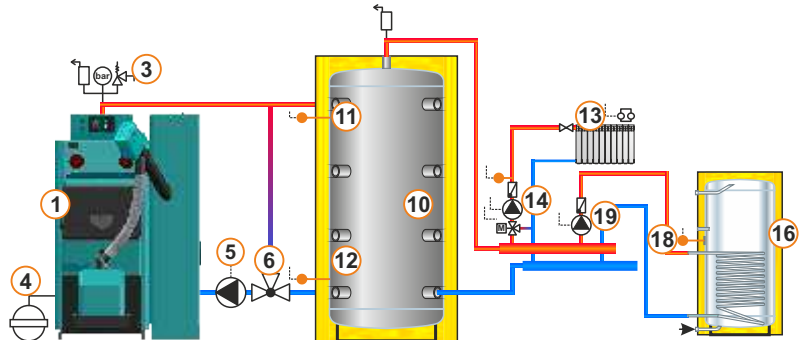
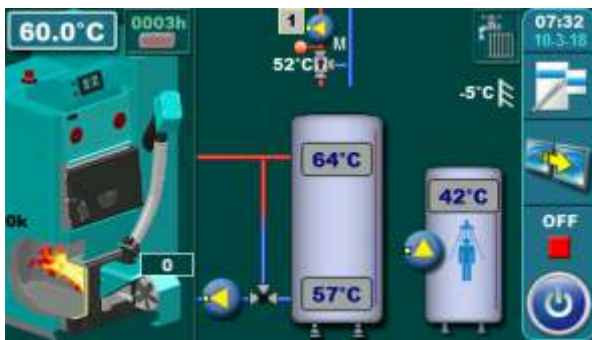

**Temperatures:** Tboiler: 80°C (80-90°C)  
dTboiler: 10°C (5-15°C)  
Tbuf: 80°C (70-80°C)  
dTbuf: 10°C (5-30°C)  
dTbuf-off: 5°C (3-50°C)

Tdhw: 50°C (10-70°C)  
dTdhw: 5°C (5-50°C)  
Tbuf min.: 20°C (5-85°C)

1. Circuit:  
Const. temp. day: 60°C (20-90°C)  
Const. temp. night: 60°C (20-90°C)  
Day room temp.: 20°C (5-30°C)  
Night room temp.: 20°C (5-30°C)

13.6. CONFIGURATION A-1-2

EKO-CK P

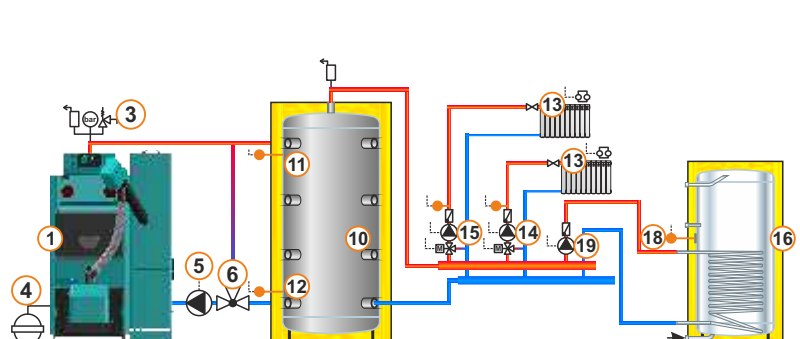
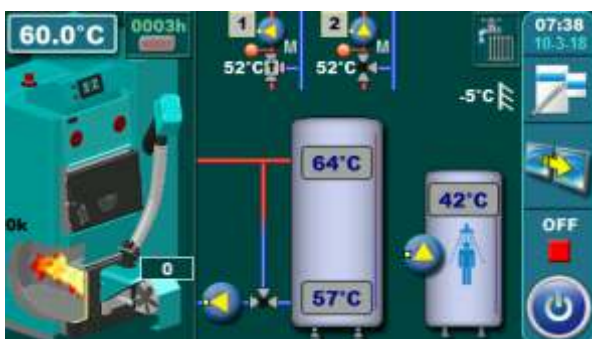

**Temperatures:** Tboiler: 80°C (80-90°C)  
dTboiler: 10°C (5-15°C)  
Tbuf: 80°C (70-80°C)  
dTbuf: 10°C (5-30°C)  
dTbuf-off: 5°C (3-50°C)

Tdhw: 50°C (10-70°C)  
dTdhw: 5°C (5-50°C)  
Tbuf min.: 20°C (5-85°C)

1. Circuit, 2. Circuit:  
Const. temp. day: 60°C (20-90°C)  
Const. temp. night: 60°C (20-90°C)  
Day room temp.: 20°C (5-30°C)  
Night room temp.: 20°C (5-30°C)

13.7. CONFIGURATION A-2-0

EKO-CK P

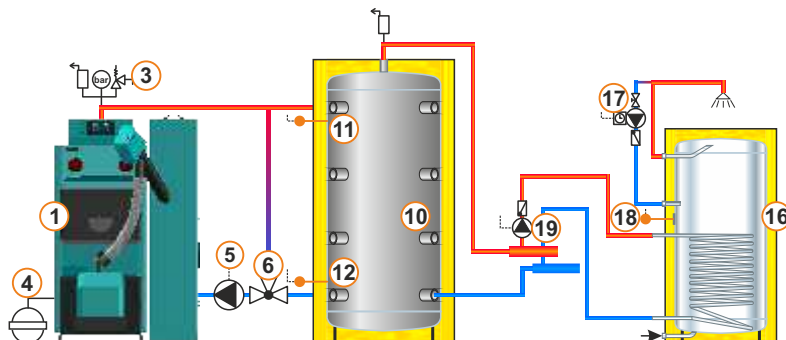
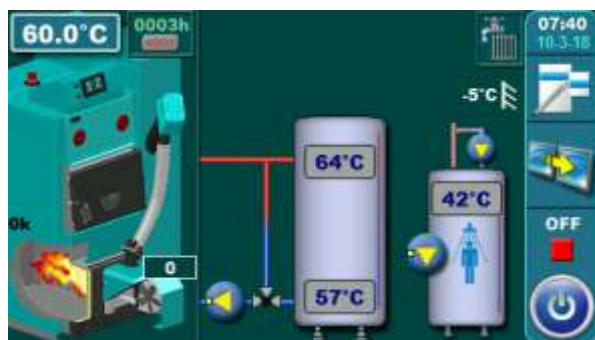

**Temperatures:** Tboiler: 80°C (80-90°C)  
 dTboiler: 10°C (5-15°C)  
 Tbuf: 80°C (70-80°C)  
 dTbuf: 10°C (5-30°C)  
 dTbuf-off: 5°C (3-50°C)

Tdhw: 50°C (10-70°C)  
 dTdhw: 5°C (5-50°C)  
 Tbuf min.: 20°C (5-85°C)

13.8. CONFIGURATION A-2-1

EKO-CK P

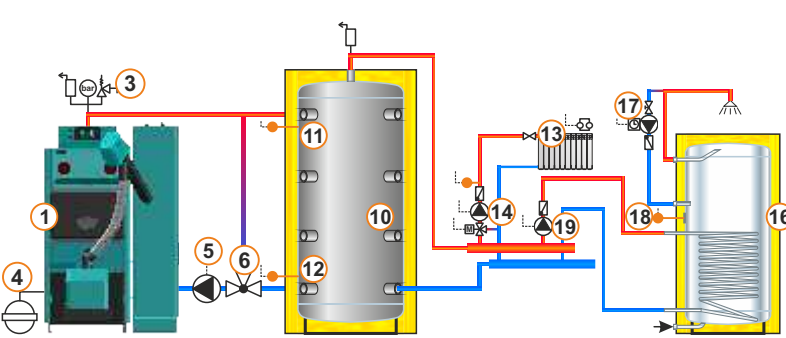
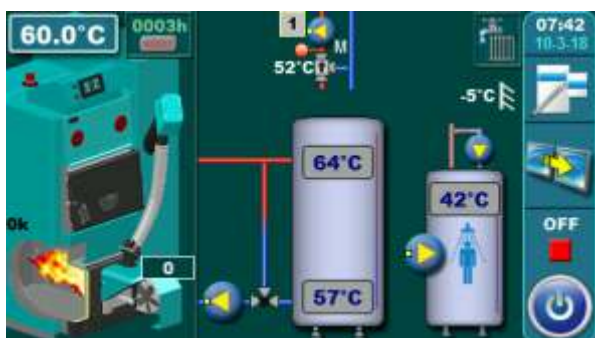

**Temperatures:** Tboiler: 80°C (80-90°C)  
 dTboiler: 10°C (5-15°C)  
 Tbuf: 80°C (70-80°C)  
 dTbuf: 10°C (5-30°C)  
 dTbuf-off: 5°C (3-50°C)

Tdhw: 50°C (10-70°C)  
 dTdhw: 5°C (5-50°C)  
 Tbuf min.: 20°C (5-85°C)

1. Circuit:  
 Const. temp. day: 60°C (20-90°C)  
 Const. temp. night: 60°C (20-90°C)  
 Day room temp.: 20°C (5-30°C)  
 Night room temp.: 20°C (5-30°C)

13.9. CONFIGURATION A-2-2

EKO-CK P

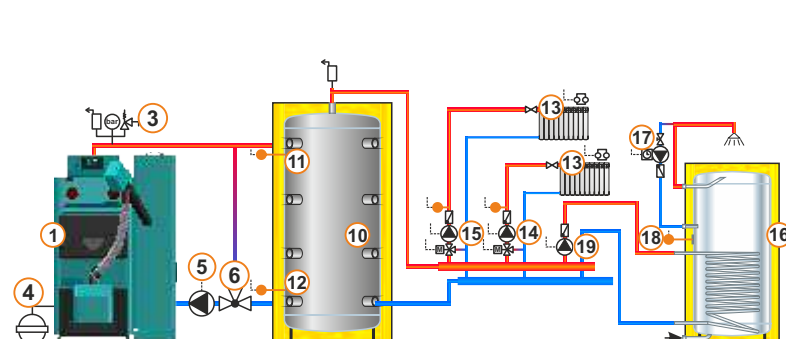
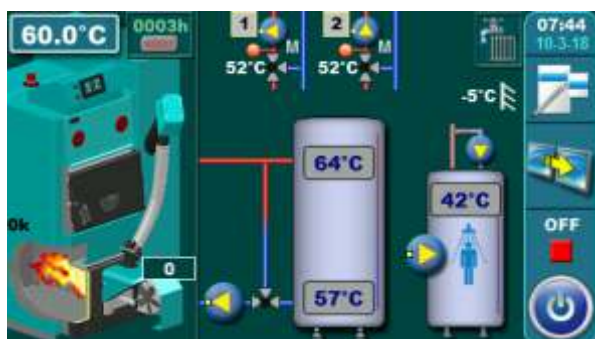

**Temperatures:** Tboiler: 80°C (70-90°C)  
 dTboiler: 10°C (5-15°C)  
 Tbuf: 80°C (70-80°C)  
 dTbuf: 10°C (5-30°C)  
 dTbuf-off: 5°C (3-50°C)

Tdhw: 50°C (10-60°C)  
 dTdhw: 5°C (5-50°C)  
 Tbuf min.: 20°C (5-85°C)

1. Circuit, 2 Circuit:  
 Const. temp. day: 60°C (20-90°C)  
 Const. temp. night: 60°C (20-90°C)  
 Day room temp.: 20°C (5-30°C)  
 Night room temp.: 20°C (5-30°C)

## 13.10. CONFIGURATION A-7-0

EKO-CKB P

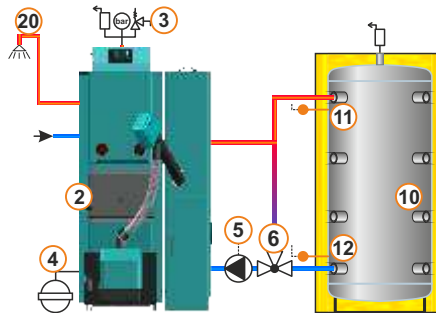
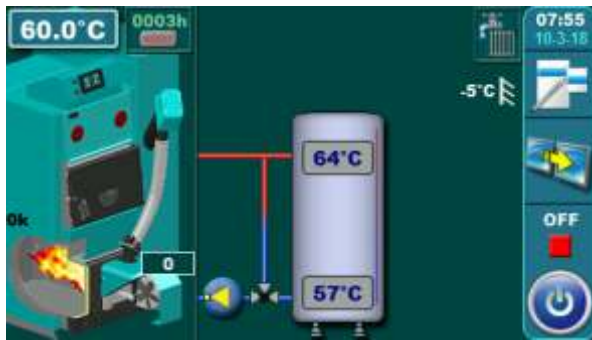

### Temperatures:

Tboiler:

- Mode: -> Heating+DHW: 80°C (80-90°C)
- > DHW: 70°C (70-80°C)

dTboiler:

- Mode: - Heating+DHW: 10°C (5-15°C)
- DHW: 10°C (5-10°C)

Tdhw:

- Mode: - Heating+DHW: Tdhw=Tboiler=80°C
- DHW: Tdhw=Tboiler=70°C

dTdhw:

- Mode: - Heating+DHW: 15°C (10-40°C)
- DHW: 15°C (10-40°C)

Tbuf: 80°C (70-80°C)

- dTbuf: 10°C (5-30°C)
- dTbuf-off: 5°C (3-50°C)

## 13.11. CONFIGURATION A-7-1

EKO-CKB P

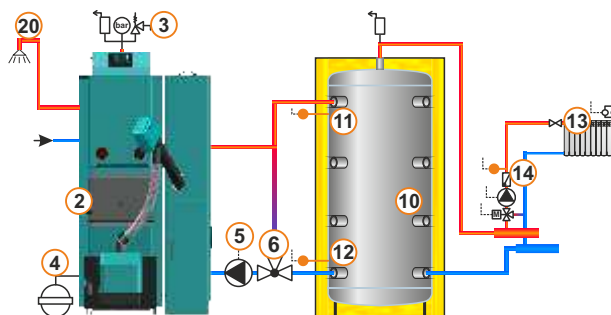
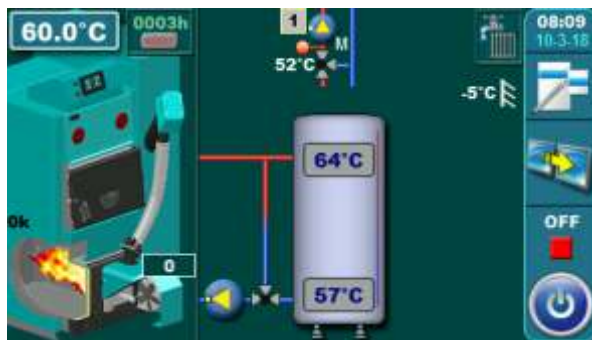

### Temperatures:

Tboiler:

- Mode: -> Heating+DHW: 80°C (80-90°C)
- > DHW: 70°C (70-80°C)

dTboiler:

- Mode: - Heating+DHW: 10°C (5-15°C)
- DHW: 10°C (5-10°C)

Tdhw:

- Mode: - Heating+DHW: Tdhw=Tboiler=80°C
- DHW: Tdhw=Tboiler=70°C

dTdhw:

- Mode: - Heating+DHW: 15°C (10-40°C)
- DHW: 15 (10-40°C)

Tbuf: 80°C (70-80°C)

- dTbuf: 10°C (5-30°C)
- dTbuf-off: 5°C (3-50°C)
- Tbuf min.: 20°C (5-85°C)

Circuit 1:

- Const. temp. day: 60°C (20-90°C)
- Const. temp. night: 60°C (20-90°C)
- Day room temp.: 20°C (5-30°C)
- Night room temp.: 20°C (5-30°C)

## 13.12. CONFIGURATION A-7-2

EKO-CKB P

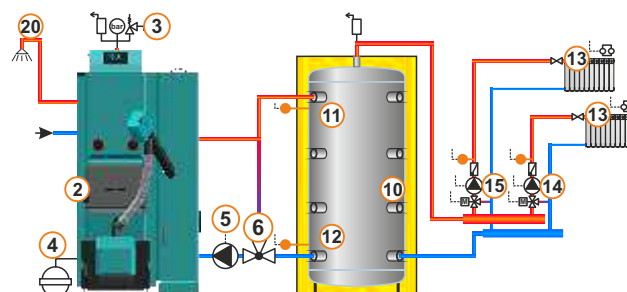
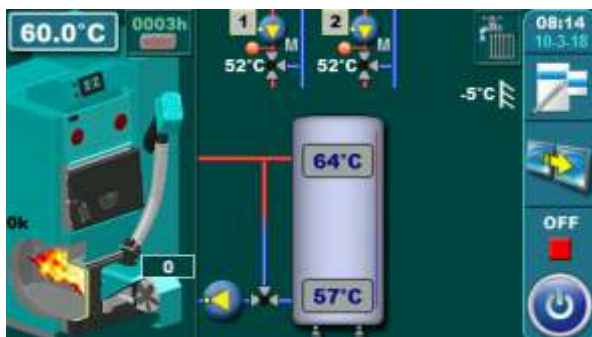

### Temperatures:

Tboiler:

- Mode: -> Heating+DHW: 80°C (80-90°C)
- > DHW: 70°C (70-80°C)

dTboiler:

- Mode: - Heating+DHW: 10°C (5-15°C)
- DHW: 10°C (5-10°C)

Tdhw:

- Mode: - Heating+DHW: Tdhw=Tboiler=80°C
- DHW: Tdhw=Tboiler=70°C

dTdhw:

- Mode: - Heating+DHW: 15°C (10-40°C)
- DHW: 15°C (10-40°C)

Tbuf: 80°C (70-80°C)

- dTbuf: 10°C (5-30°C)
- dTbuf-off: 5°C (3-50°C)
- Tbuf min.: 20°C (5-85°C)

Circuit 1, Circuit 2:

- Const. temp. day: 60°C (20-90°C)
- Const. temp. night: 60°C (20-90°C)
- Day room temp.: 20°C (5-30°C)
- Night room temp.: 20°C (5-30°C)

13.13. CONFIGURATION A-8-0

EKO-CKB P

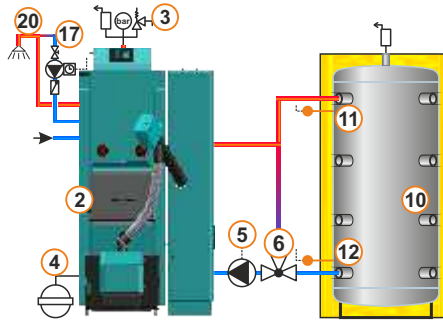
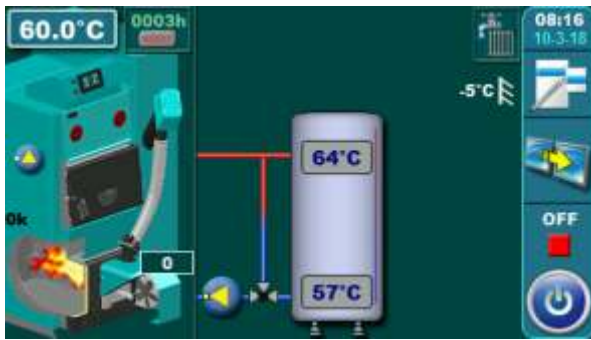

**Temperatures:** Tboiler:  
 - Mode: -> Heating+DHW: 80°C (80-90°C)  
 -> DHW: 70°C (70-80°C)  
 dTboiler:  
 - Mode: - Heating+DHW: 10°C (5-15°C)  
 - DHW: 10°C (5-10°C)

Tdhw:  
 - Mode: - Heating+DHW: Tdhw=Tboiler=80°C  
 - DHW: Tdhw=Tboiler=70°C  
 dTdhw:  
 - Mode: - Heating+DHW: 15°C (10-40°C)  
 - DHW: 15°C (10-40°C)

Tbuf: 80°C (70-80°C)  
 dTbuf: 10°C (5-30°C)  
 dTbuf-off: 10°C (3-50°C)

13.14. CONFIGURATION A-8-1

EKO-CKB P

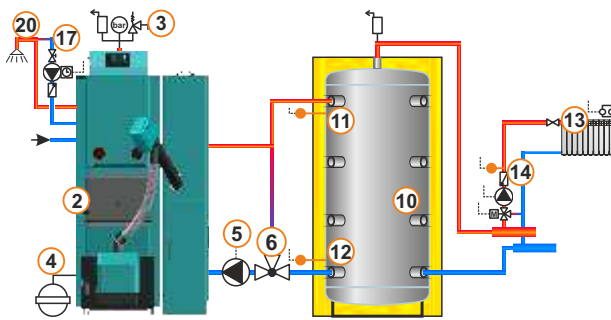
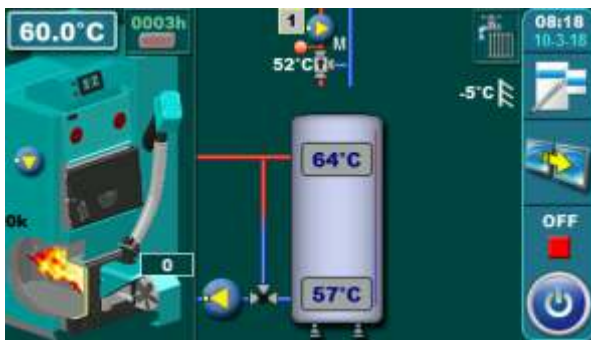

**Temperatures:**

Tboiler:  
 - Mode: -> Heating+DHW: 80°C (80-90°C)  
 -> DHW: 70°C (70-80°C)  
 dTboiler:  
 - Mode: - Heating+DHW: 10°C (5-15°C)  
 - DHW: 10°C (5-10°C)

Tdhw:  
 - Mode: - Heating+DHW: Tdhw=Tboiler=80°C  
 - DHW: Tdhw=Tboiler=70°C  
 dTdhw:  
 - Mode: - Heating+DHW: 15°C (10-40°C)  
 - DHW: 15°C (10-40°C)

Tbuf: 80°C (70-80°C)  
 dTbuf: 10°C (5-30°C)  
 dTbuf-off: 5°C (3-50°C)  
 Tbuf min.: 20°C (5-85°C)

Circuit 1:  
 Const. temp. day: 60°C (20-90°C)  
 Const. temp. night: 60°C (20-90°C)  
 Day room temp.: 20°C (5-30°C)  
 Night room temp.: 20°C (5-30°C)

13.15. CONFIGURATION A-8-2

EKO-CKB P

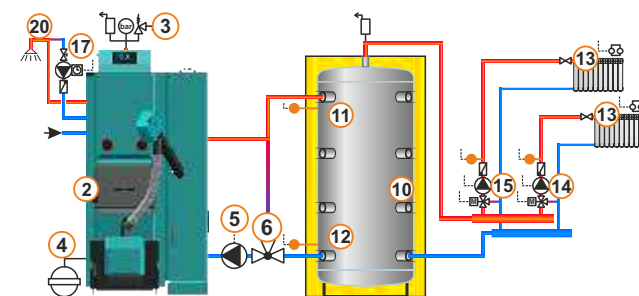
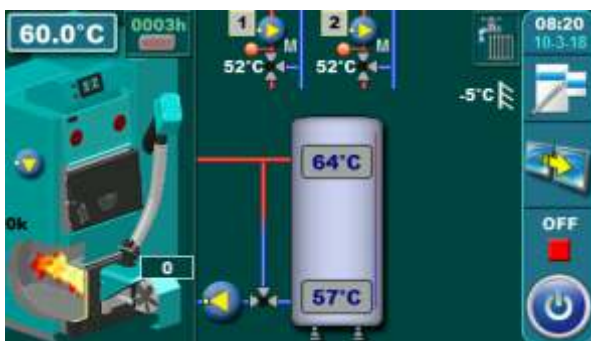

**Temperatures:**

Tboiler:  
 - Mode: -> Heating+DHW: 80°C (80-90°C)  
 -> DHW: 70°C (70-80°C)  
 dTboiler:  
 - Mode: - Heating+DHW: 10°C (5-15°C)  
 - DHW: 10°C (5-10°C)

Tdhw:  
 - Mode: - Heating+DHW: Tdhw=Tboiler=80°C  
 - DHW: Tdhw=Tboiler=70°C  
 dTdhw:  
 - Mode: - Heating+DHW: 15°C (10-40°C)  
 - DHW: 15°C (10-40°C)

Tbuf: 80°C (70-80°C)  
 dTbuf: 10°C (5-30°C)  
 dTbuf-off: 20°C (3-50°C)  
 Tbuf min.: 20°C (5-85°C)

Circuit 1, Circuit 2:  
 Const. temp. day: 60°C (20-90°C)  
 Const. temp. night: 60°C (20-90°C)  
 Day room temp.: 20°C (5-30°C)  
 Night room temp.: 20°C (5-30°C)

13.16. CONFIGURATION B-0-0

EKO-CK P

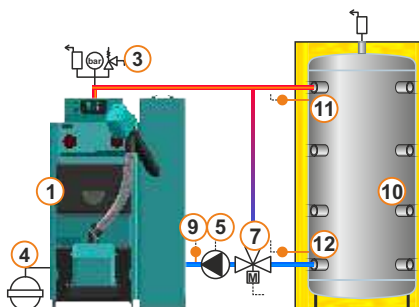
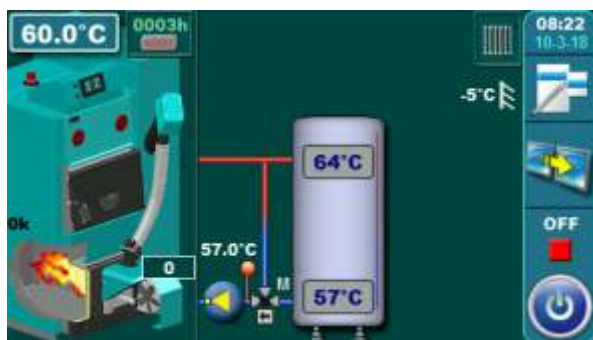

**Temperatures:** Tboiler: 80°C (80-90°C)  
 dTboiler: 10°C (5-15°C)  
 Tbuf: 80°C (70-80°C)  
 dTbuf: 10°C (5-30°C)  
 dTbuf-off: 5°C (3-50°C)

13.17. CONFIGURATION B-0-1

EKO-CK P

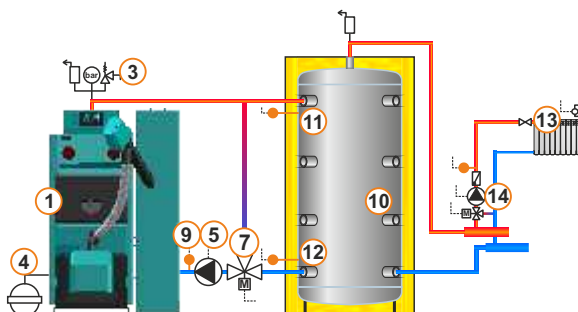
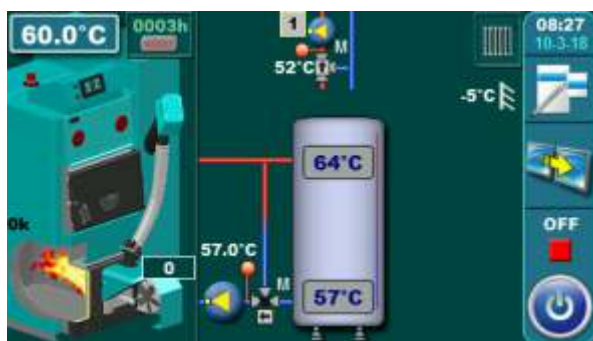

**Temperatures:** Tboiler: 80°C (80-90°C)  
 dTboiler: 10°C (5-15°C)  
 Tbuf: 80°C (70-80°C)  
 dTbuf: 10°C (5-30°C)  
 dTbuf-off: 5°C (3-50°C)

Tbuf min.: 20°C (5-85°C)

1. Circuit:  
 Const. temp. day: 60°C (20-90°C)  
 Const. temp. day: 60°C (20-90°C)  
 Day room temp.: 20°C (5-30°C)  
 Night room temp.: 20°C (5-30°C)

13.18. CONFIGURATION B-1-0

EKO-CK P

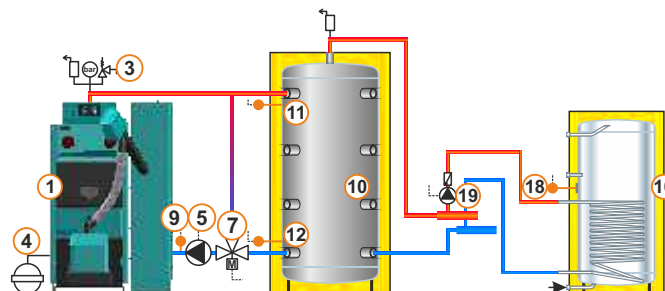
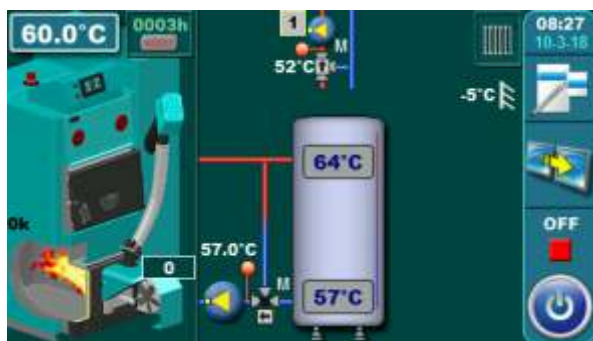

**Temperatures:** Tboiler: 80°C (80-90°C)  
 dTboiler: 10°C (5-15°C)  
 Tbuf: 80°C (70-80°C)  
 dTbuf: 10°C (5-30°C)  
 dTbuf-off: 5°C (3-50°C)

Tdhw: 50°C (10-70°C)  
 dTdhw: 5°C (10-70°C)

13.19. CONFIGURATION B-1-1

EKO-CK P

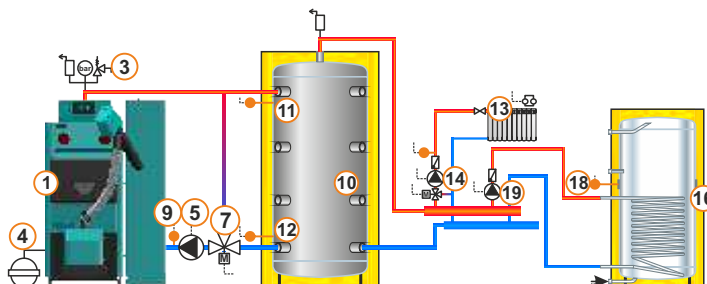
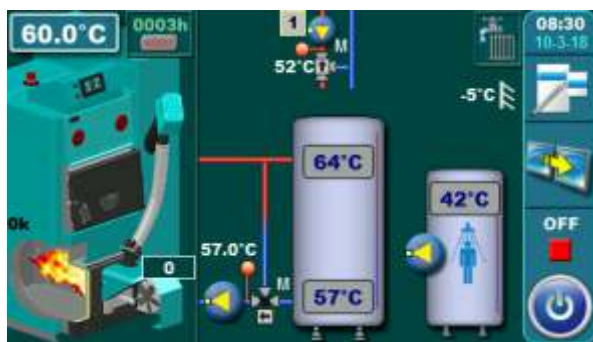

**Temperatures:** Tboiler: 80°C (80-90°C)  
dTboiler: 10°C (5-15°C)  
Tbuf: 80°C (70-80°C)  
dTbuf: 10°C (5-30°C)  
dTbuf-off: 5°C (3-50°C)

Tdhw: 50°C (10-70°C)  
dTdhw: 5°C (5-50°C)  
Tbuf min.: 20°C (5-85°C)

1. Circuit:  
Const. temp. day: 60°C (20-90°C)  
Const. temp. night: 60°C (20-90°C)  
Day room temp.: 20°C (5-30°C)  
Night room temp.: 20°C (5-30°C)

13.20. CONFIGURATION B-2-0

EKO-CK P

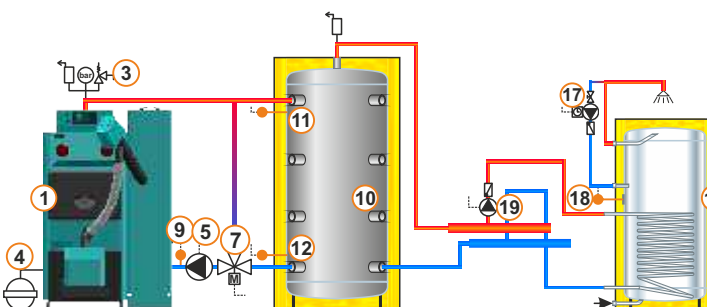
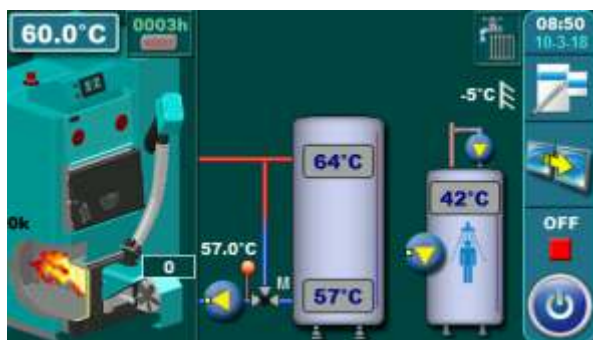

**Temperatures:** Tboiler: 80°C (80-90°C)  
dTboiler: 10°C (5-15°C)  
Tbuf: 80°C (70-80°C)  
dTbuf: 10°C (5-30°C)  
dTbuf-off: 5°C (3-50°C)

Tdhw: 50°C (10-70°C)  
dTdhw: 5°C (5-50°C)

13.21. CONFIGURATION B-2-1

EKO-CK P

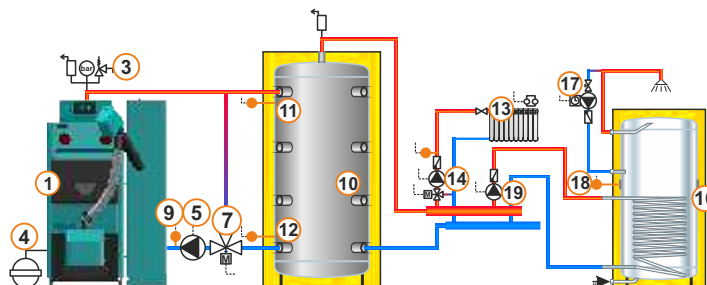
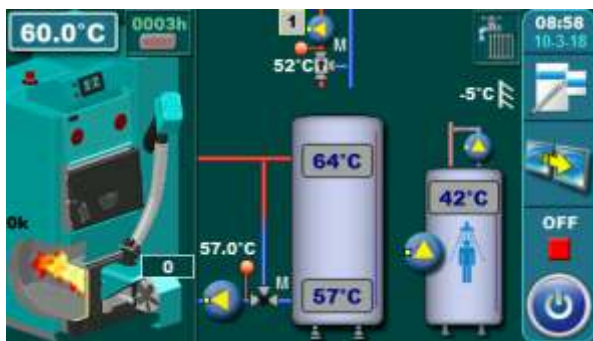

**Temperatures:** Tboiler: 80°C (80-90°C)  
dTboiler: 10°C (5-15°C)  
Tbuf: 80°C (70-80°C)  
dTbuf: 10°C (5-30°C)  
dTbuf-off: 5°C (3-50°C)

Tdhw: 50°C (10-70°C)  
dTdhw: 5°C (5-50°C)  
Tbuf min.: 20°C (5-85°C)

1. Circuit:  
Const. temp. day: 60°C (20-90°C)  
Const. temp. night: 60°C (20-90°C)  
Day room temp.: 20°C (5-30°C)  
Night room temp.: 20°C (5-30°C)

## 13.22. CONFIGURATION B-7-0

EKO-CKB P

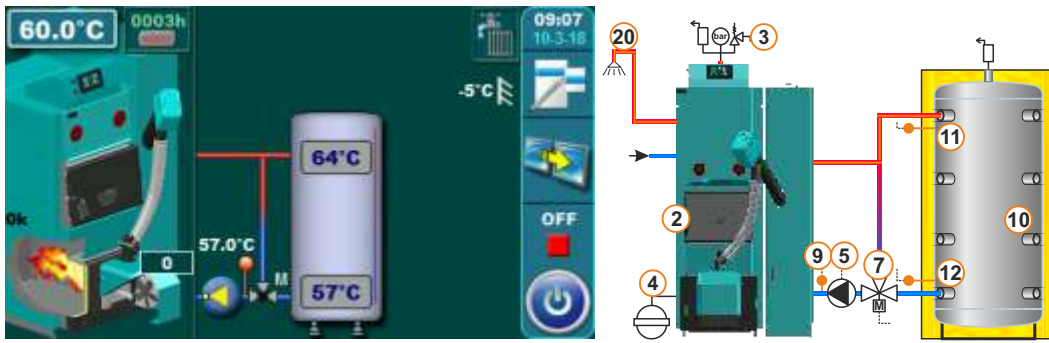

### Temperatures:

Tboiler:

- Mode: -> Heating+DHW: 80°C (80-90°C)
- > DHW: 70°C (70-80°C)

dTboiler:

- Mode: - Heating+DHW: 10°C (5-15°C)
- DHW: 10°C (5-10°C)

Tdhw:

- Mode: - Heating+DHW: Tdhw=Tboiler=80°C
- DHW: Tdhw=Tboiler=70°C

dTdhw:

- Mode: - Heating+DHW: 15°C (10-40°C)
- DHW: 15°C (10-40°C)

Tbuf: 80°C (70-80°C)

- dTbuf: 10°C (5-30°C)
- dTbuf-off: 10°C (3-50°C)

## 13.23. CONFIGURATION B-7-1

EKO-CKB P

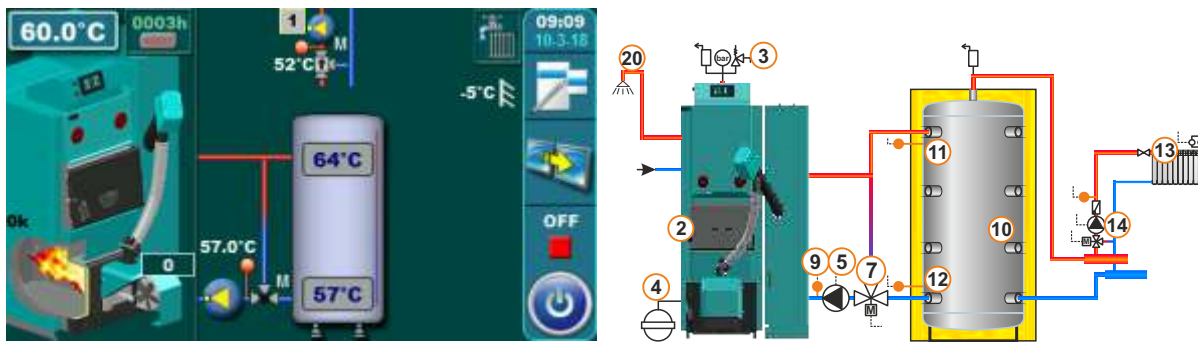

### Temperatures:

Tboiler:

- Mode: -> Heating+DHW: 80°C (80-90°C)
- > DHW: 70°C (70-80°C)

dTboiler:

- Mode: - Heating+DHW: 10°C (5-15°C)
- DHW: 10°C (5-10°C)

Tdhw:

- Mode: - Heating+DHW: Tdhw=Tboiler=80°C
- DHW: Tdhw=Tboiler=70°C

dTdhw:

- Mode: - Heating+DHW: 15°C (10-40°C)
- DHW: 15°C (10-40°C)

Tbuf: 80°C (70-80°C)

- dTbuf: 10°C (5-30°C)
- dTbuf-off: 5°C (3-50°C)
- Tbuf min.: 20°C (5-85°C)

Circuit 1:

- Const. temp. day: 60°C (20-90°C)
- Const. temp. night: 60°C (20-90°C)
- Day room temp.: 20°C (5-30°C)
- Night room temp.: 20°C (5-30°C)

## 13.24. CONFIGURATION B-8-0

EKO-CKB P

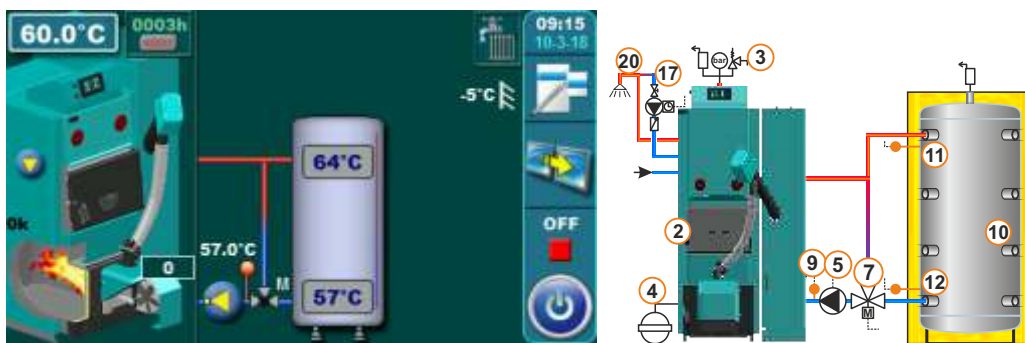

### Temperatures:

Tboiler:

- Mode: -> Heating+DHW: 80°C (80-90°C)
- > DHW: 70°C (70-80°C)

dTboiler:

- Mode: - Heating+DHW: 10°C (5-15°C)
- DHW: 10°C (5-10°C)

Tdhw:

- Mode: - Heating+DHW: Tdhw=Tboiler=80°C
- DHW: Tdhw=Tboiler=70°C

dTdhw:

- Mode: - Heating+DHW: 15°C (10-40°C)
- DHW: 15°C (10-40°C)

Tbuf: 80°C (70-80°C)

- dTbuf: 10°C (5-30°C)
- dTbuf-off: 10°C (3-50°C)

13.25. CONFIGURATION B-8-1

EKO-CKB P

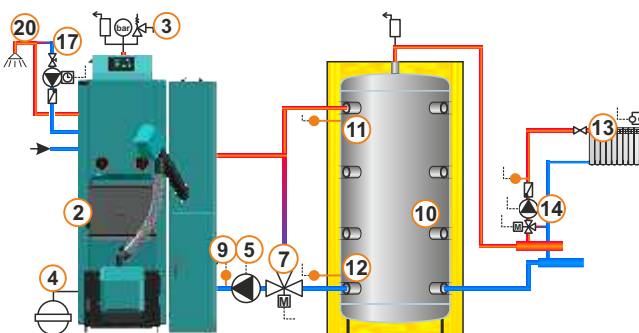
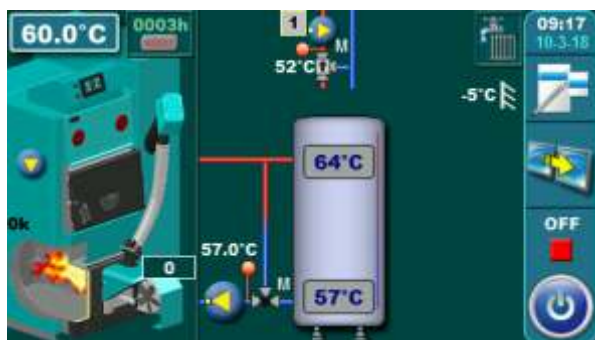

**Temperatures:**

- |  |   |  |  |
|--|---|--|--|
| Tboiler:<br>- Mode: -> Heating+DHW: 80°C (80-90°C)<br>-> DHW: 70°C (70-80°C) | Tdhw:<br>- Mode: - Heating+DHW: Tdhw=Tboiler=80°C<br>- DHW: Tdhw=Tboiler=70°C | Tbuf: 80°C (70-80°C)<br>dTbuf: 10°C (5-30°C)<br>Tbuf min.: 20°C (5-85°C) | Circuit 1:<br>Const. temp. day: 60°C (20-90°C)<br>Const. temp. night: 60°C (20-90°C)<br>Day room temp.: 20°C (5-30°C)<br>Night room temp.: 20°C (5-30°C) |
| dTboiler:<br>- Mode: - Heating+DHW: 10°C (5-15°C)<br>- DHW: 10°C (5-10°C)    | dTdhw:<br>- Mode: - Heating+DHW: 15°C (10-40°C)<br>- DHW: 15°C (10-40°C)      |  |  |

13.26. CONFIGURATION C-0-0

EKO-CK P

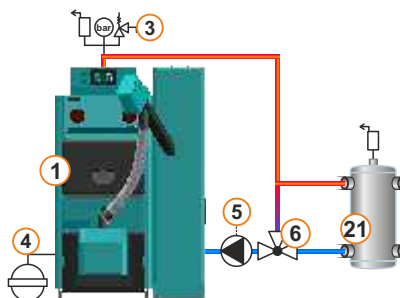
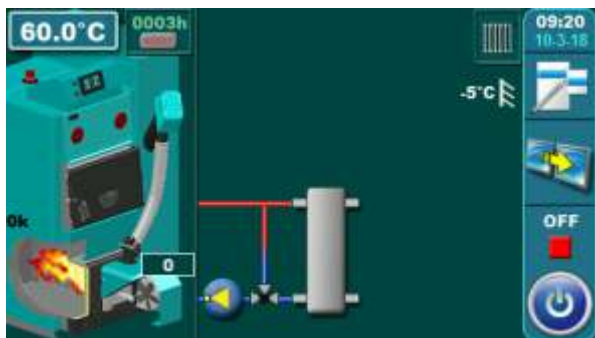

- Temperatures:** Tboiler: 80°C (70-90°C)  
dTboiler: 10°C (5-15°C)

13.27. CONFIGURATION C-0-1

EKO-CK P

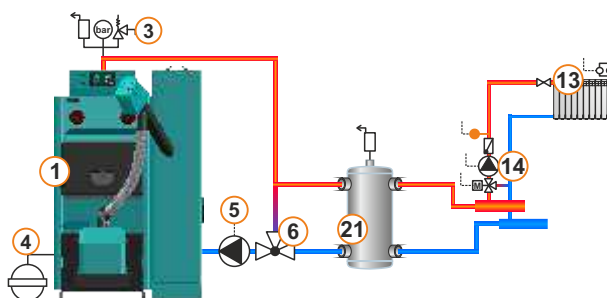
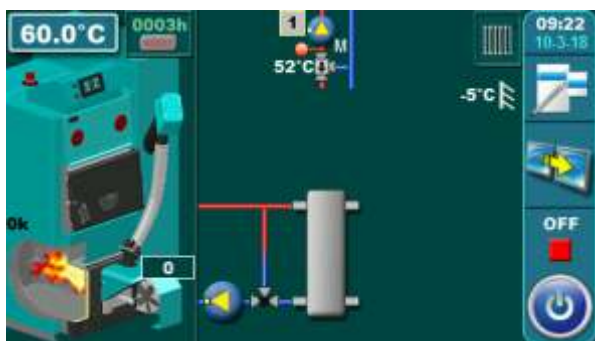

- Temperatures:** Tboiler: 80°C (70-90°C)  
dTboiler: 10°C (5-15°C)
- Circuit 1:  
Const. temp. day: 60°C (20-90°C)  
Const. temp. night: 60°C (20-90°C)  
Day room temp.: 20°C (5-30°C)  
Night room temp.: 20°C (5-30°C)

13.28. CONFIGURATION C-0-2

EKO-CK P

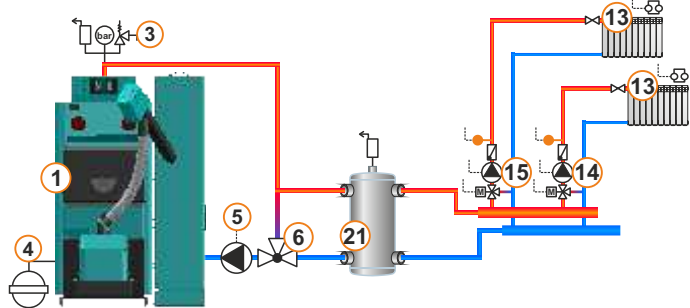
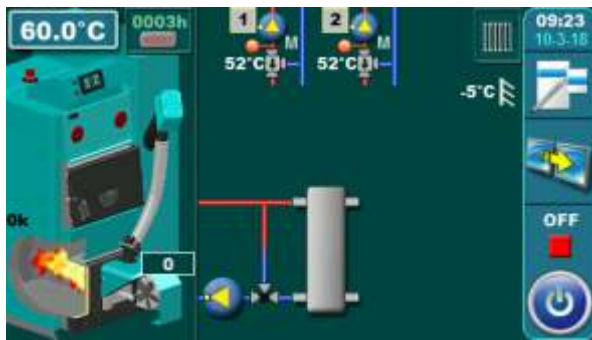

**Temperatures:** Tboiler: 80°C (70-90°C)  
dTboiler: 10°C (5-15°C)

1. Circuit, 2. Circuit:  
Const. temp. day: 60°C (20-90°C)  
Const. temp. night: 60°C (20-90°C)  
Day room temp.: 20°C (5-30°C)  
Night room temp.: 20°C (5-30°C)

13.29. CONFIGURATION C-1-0

EKO-CK P

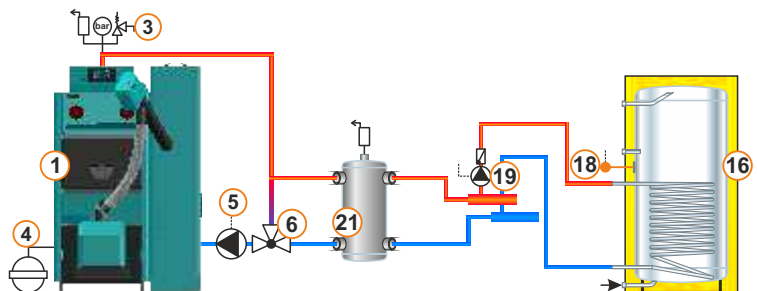
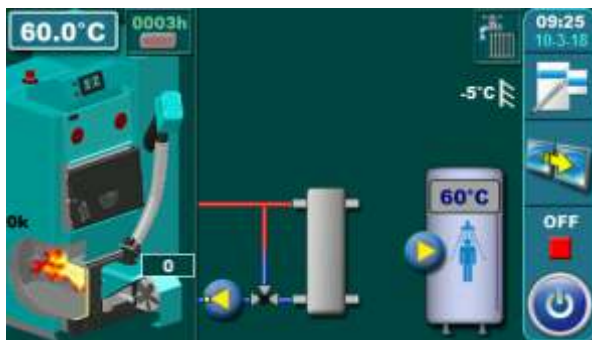

**Temperatures:** Tboiler: 80°C (70-90°C)  
dTboiler: 10°C (5-15°C)  
Tdhw: 50°C (10-70°C)  
dTdhw: 5°C (5-50°C)

13.30. CONFIGURATION C-1-1

EKO-CK P

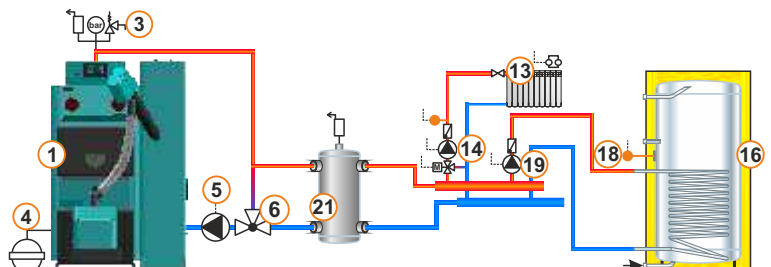
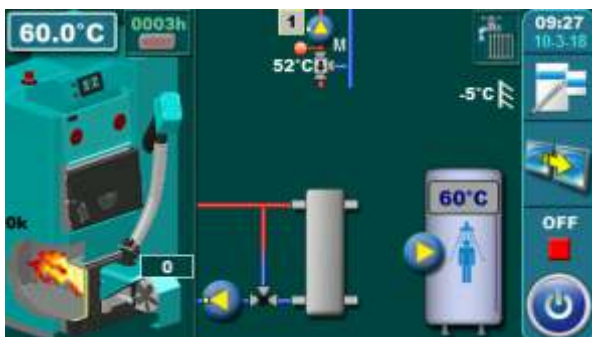

**Temperatures:** Tboiler: 80°C (70-90°C)  
dTboiler: 10°C (5-15°C)  
Tdhw: 50°C (10-70°C)  
dTdhw: 5°C (5-50°C)

Circuit 1:  
Const. temp. day: 60°C (20-90°C)  
Const. temp. night: 60°C (20-90°C)  
Day room temp.: 20°C (5-30°C)  
Night room temp.: 20°C (5-30°C)

13.31. CONFIGURATION C-1-2

EKO-CK P

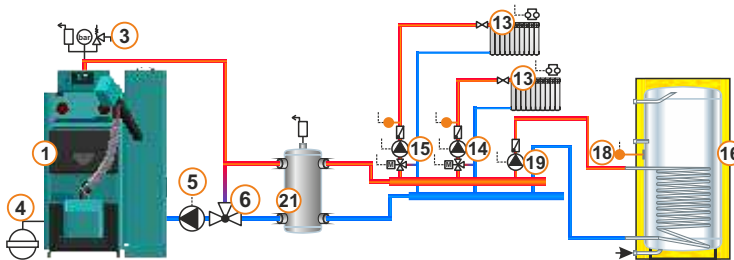
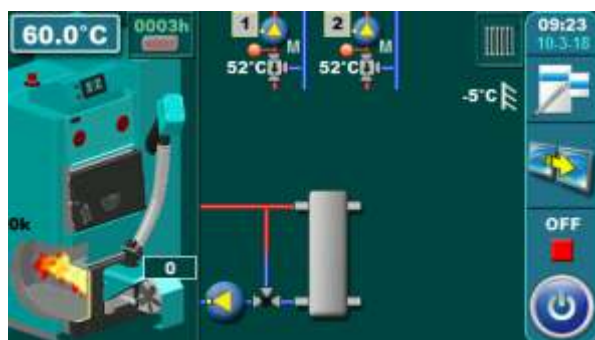

**Temperatures:** Tboiler: 80°C (70-90°C)  
dTboiler: 10°C (5-15°C)  
Tdhw: 50°C (10-70°C)  
dTdhw: 5°C (5-50°C)

1. Circuit, 2. Circuit:  
Const. temp. day: 60°C (20-90°C)  
Const. temp. night: 60°C (20-90°C)  
Day room temp.: 20°C (5-30°C)  
Night room temp.: 20°C (5-30°C)

13.32. CONFIGURATION C-2-0

EKO-CK P

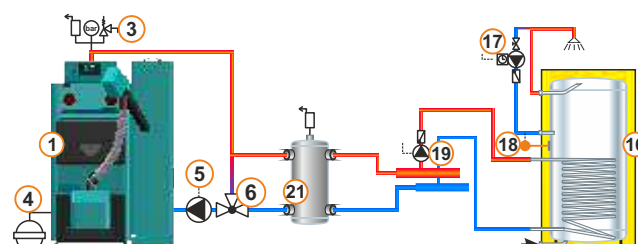
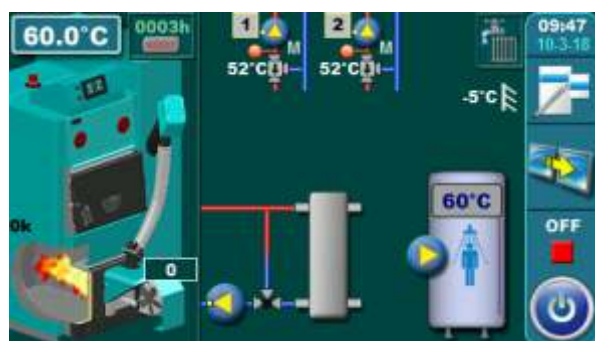

**Temperatures:** Tboiler: 80°C (70-90°C)  
dTboiler: 10°C (5-15°C)  
Tdhw: 50°C (10-70°C)  
dTdhw: 5°C (5-50°C)

13.33. CONFIGURATION C-2-1

EKO-CK P

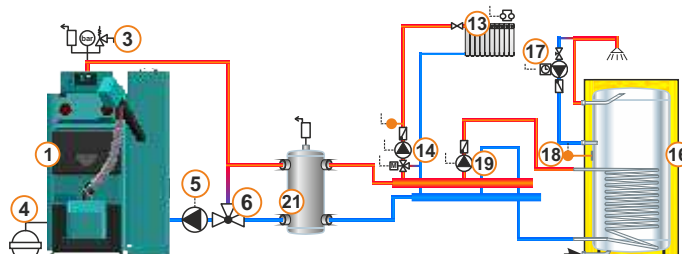
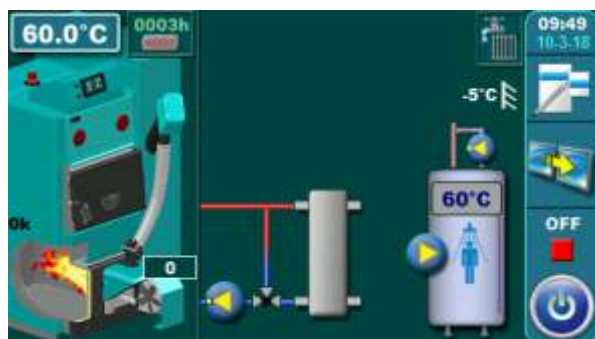

**Temperatures:** Tboiler: 80°C (70-90°C)  
dTboiler: 10°C (5-15°C)  
Tdhw: 50°C (10-70°C)  
dTdhw: 5°C (5-50°C)

1. Circuit:  
Const. temp. day: 60°C (20-90°C)  
Const. temp. night: 60°C (20-90°C)  
Day room temp.: 20°C (5-30°C)  
Night room temp.: 20°C (5-30°C)

13.34. CONFIGURATION C-2-2

EKO-CK P

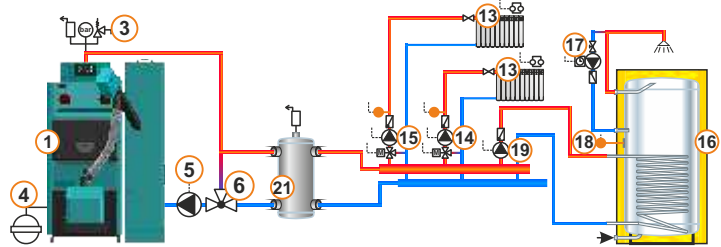
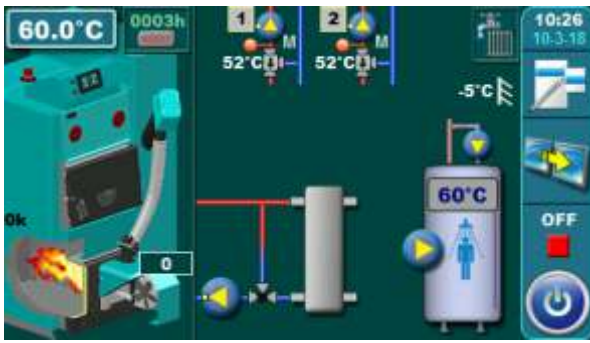

**Temperatures:** Tboiler: 80°C (70-90°C)  
 dTboiler: 10°C (5-15°C)  
 Tdhw: 50°C (10-70°C)  
 dTdhw: 5°C (5-50°C)

1. Circuit, 2. Circuit:  
 Const. temp. day: 60°C (20-90°C)  
 Const. temp. night: 60°C (20-90°C)  
 Day room temp.: 20°C (5-30°C)  
 Night room temp.: 20°C (5-30°C)

13.35. CONFIGURATION C-7-0

EKO-CKB P

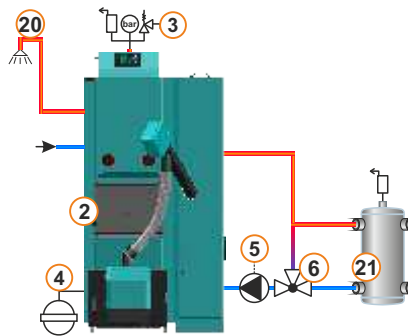
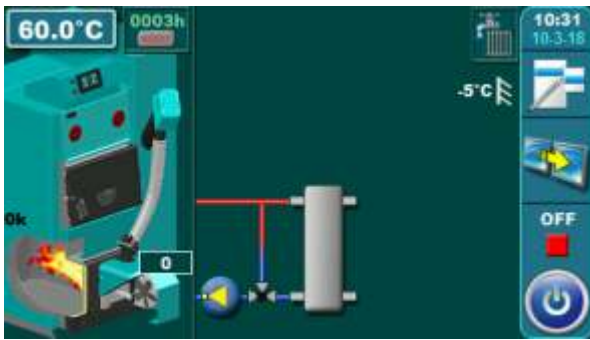

**Temperatures:** Tboiler:  
 - Mode: -> Heating+DHW: 80°C (70-90°C)  
           -> DHW: 70°C (70-80°C)  
 dTboiler: - Heating+DHW: 10°C (5-15°C)  
 - Mode: - DHW: 10°C (5-10°C)

Tdhw:  
 - Mode: - Heating+DHW: Tdhw=Tboiler=80°C  
           - DHW: Tdhw=Tboiler=70°C  
 dTdhw: - Heating+DHW: 15°C (10-40°C)  
 - Mode: - DHW: 15 (10-40°C)

13.36. CONFIGURATION C-7-1

EKO-CKB P

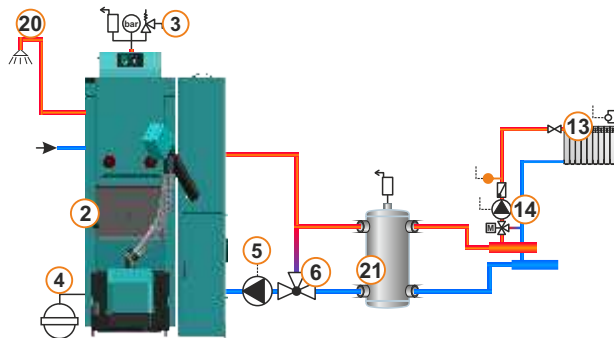
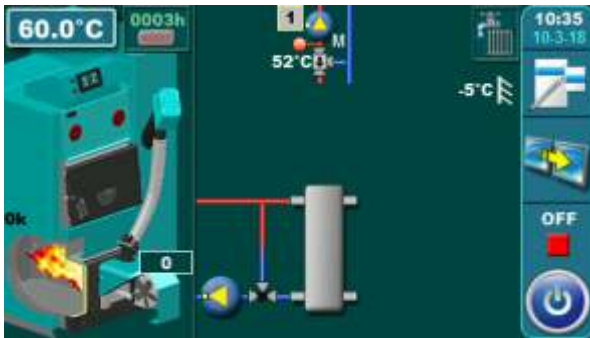

**Temperatures:** Tboiler:  
 - Mode: -> Heating+DHW: 80°C (70-90°C)  
           -> DHW: 70°C (70-80°C)  
 dTboiler:  
 - Mode: - Heating+DHW: 10°C (5-15°C)  
           - DHW: 10°C (5-10°C)

Tdhw:  
 - Mode: - Heating+DHW: Tdhw=Tboiler=80°C  
           - DHW: Tdhw=Tboiler=70°C  
 dTdhw:  
 - Mode: - Heating+DHW: 15°C (10-40°C)  
           - DHW: 15°C (10-40°C)

1. Circuit:  
 Const. temp. day: 60°C (20-90°C)  
 Const. temp. night: 60°C (20-90°C)  
 Day room temp.: 20°C (5-30°C)  
 Night room temp.: 20°C (5-30°C)

13.37. CONFIGURATION C-7-2

EKO-CKB P

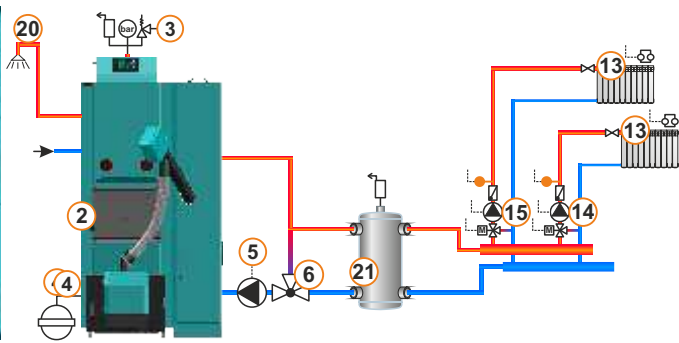
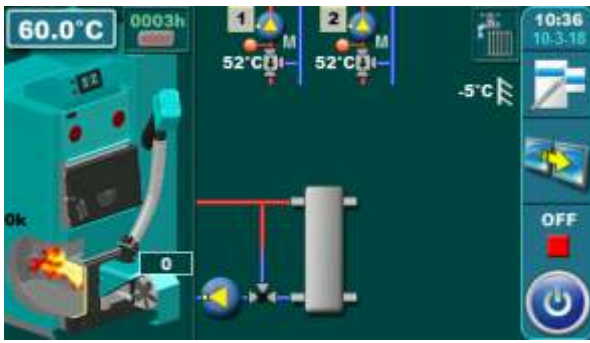

**Temperatures:** Tboiler:  
 - Mode: -> Heating+DHW: 80°C (70-90°C)  
 -> DHW: 70°C (70-80°C)  
 dTboiler:  
 - Mode: - Heating+DHW: 10°C (5-15°C)  
 - DHW: 10°C (5-10°C)

Tdhw:  
 - Mode: - Heating+DHW: Tdhw=Tboiler=80°C  
 - DHW: Tdhw=Tboiler=70°C  
 dTdhw:  
 - Mode: - Heating+DHW: 15°C (10-40°C)  
 - DHW: 15°C (10-40°C)

1. Circuit, 2. Circuit:  
 Const. temp. day: 60°C (20-90°C)  
 Const. temp. night: 60°C (20-90°C)  
 Day room temp.: 20°C (5-30°C)  
 Night room temp.: 20°C (5-30°C)

13.38. CONFIGURATION C-8-0

EKO-CKB P

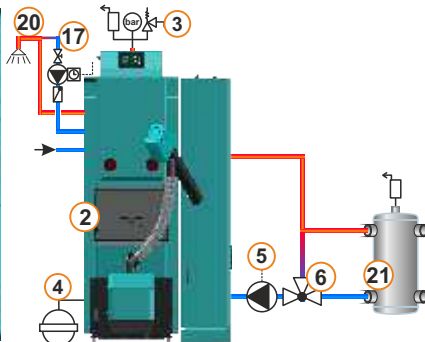
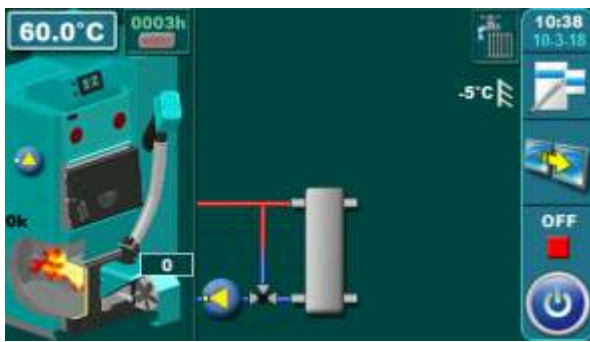

**Temperatures:** Tboiler:  
 - Mode: -> Heating+DHW: 80°C (70-90°C)  
 -> DHW: 70°C (70-80°C)  
 dTboiler: - Heating+DHW: 10°C (5-15°C)  
 - Mode: - DHW: 10°C (5-10°C)

Tdhw:  
 - Mode: - Heating+DHW: Tdhw=Tboiler=80°C  
 - DHW: Tdhw=Tboiler=70°C  
 dTdhw: - Heating+DHW: 15°C (10-40°C)  
 - Mode: - DHW: 15 (10-40°C)

13.39. CONFIGURATION C-8-1

EKO-CKB P

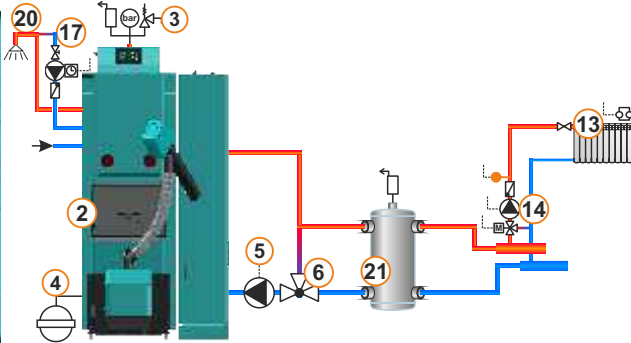
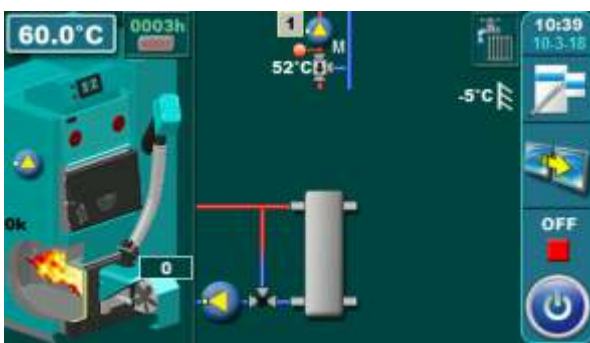

**Temperatures:**  
 Tboiler:  
 - Mode: -> Heating+DHW: 80°C (70-90°C)  
 -> DHW: 70°C (70-80°C)  
 dTboiler:  
 - Mode: - Heating+DHW: 10°C (5-15°C)  
 - DHW: 10°C (5-10°C)

Tdhw:  
 - Mode: - Heating+DHW: Tdhw=Tboiler=80°C  
 - DHW: Tdhw=Tboiler=70°C  
 dTdhw:  
 - Mode: - Heating+DHW: 15°C (10-40°C)  
 - DHW: 15°C (10-40°C)

1. Circuit :  
 Const. temp. day: 60°C (20-90°C)  
 Const. temp. night: 60°C (20-90°C)  
 Day room temp.: 20°C (5-30°C)  
 Night room temp.: 20°C (5-30°C)

13.40. CONFIGURATION C-8-2

EKO-CKB P

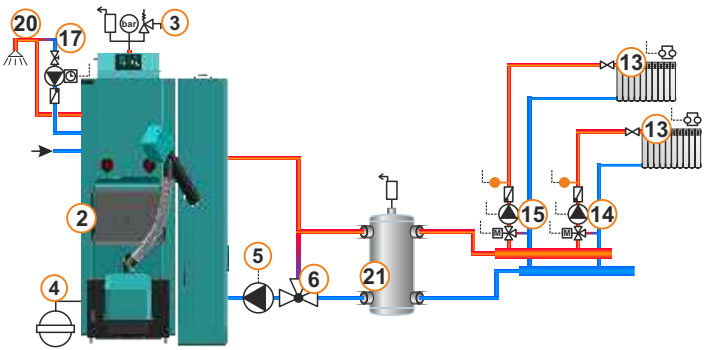
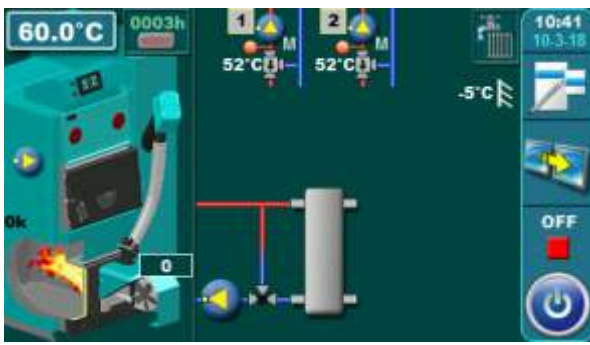

**Temperatures:** Tboiler:  
 - Mode: -> Heating+DHW: 80°C (70-90°C)  
 -> DHW: 70°C (70-80°C)  
 dTboiler:  
 - Mode: - Heating+DHW: 10°C (5-15°C)  
 - DHW: 10°C (5-10°C)

Tdhw:  
 - Mode: - Heating+DHW: Tdhw=Tboiler=80°C  
 - DHW: Tdhw=Tboiler=70°C  
 dTdhw:  
 - Mode: - Heating+DHW: 15°C (10-40°C)  
 - DHW: 15°C (10-40°C)

1. Circuit, 2. Circuit:  
 Const. temp. day: 60°C (20-90°C)  
 Const. temp. night: 60°C (20-90°C)  
 Day room temp.: 20°C (5-30°C)  
 Night room temp.: 20°C (5-30°C)

13.41. CONFIGURATION D-0-0

EKO-CK P

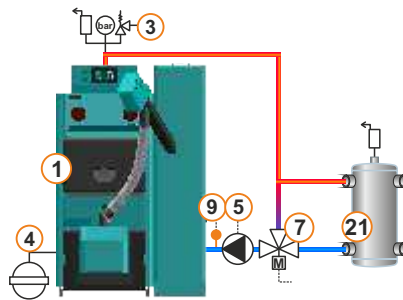
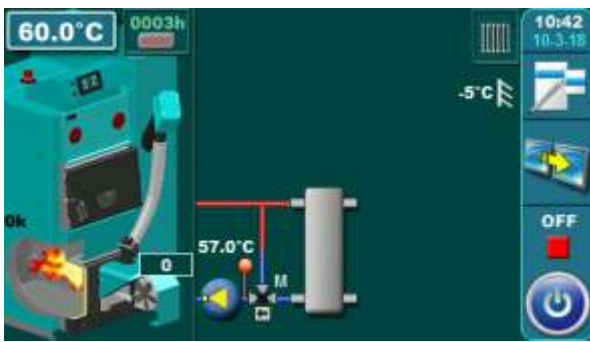

**Temperatures:** Tboiler: 80°C (70-90°C)  
 dTboiler: 10°C (5-15°C)

13.42. CONFIGURATION D-0-1

EKO-CK P

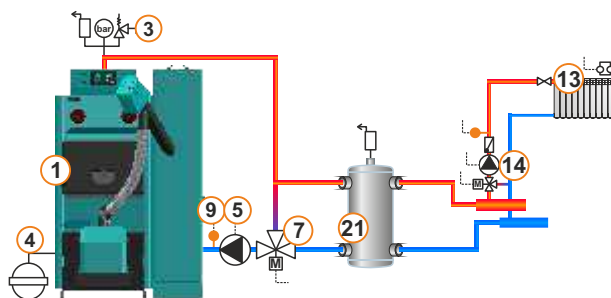
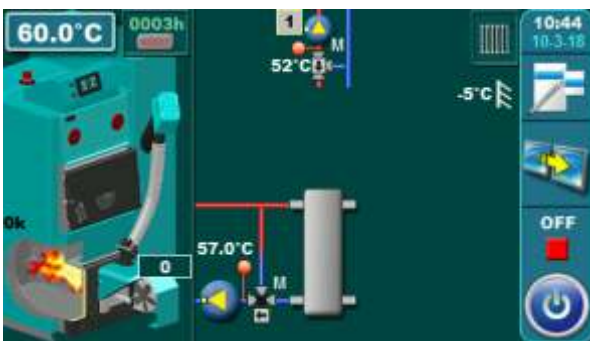

**Temperatures:** Tboiler: 80°C (70-90°C)  
 dTboiler: 10°C (5-15°C)

1. Circuit:  
 Const. temp. day: 60°C (20-90°C)  
 Const. temp. night: 60°C (20-90°C)  
 Day room temp.: 20°C (5-30°C)  
 Night room temp.: 20°C (5-30°C)

13.43. CONFIGURATION D-1-0

EKO-CK P

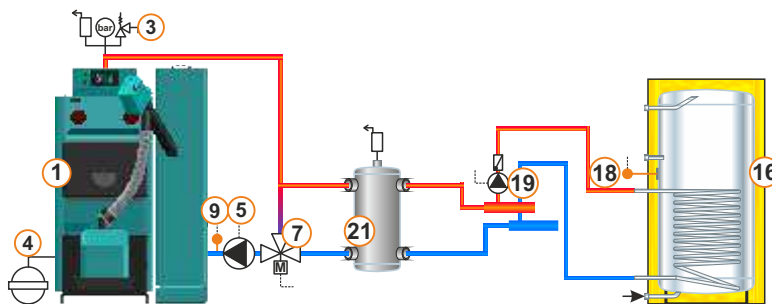
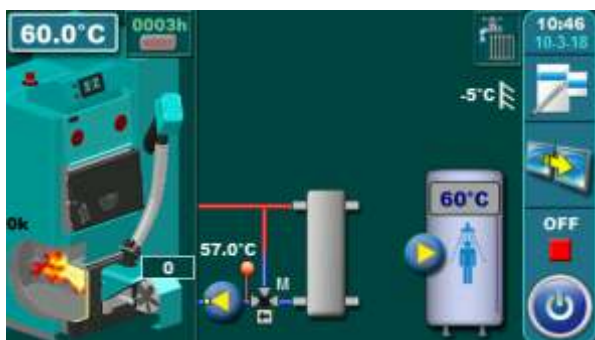

**Temperatures:** Tboiler: 80°C (70-90°C)  
 dTboiler: 10°C (5-15°C)  
 Tdhw: 50°C (10-70°C)  
 dTdhw: 5°C (5-50°C)

13.44. CONFIGURATION D-1-1

EKO-CK P

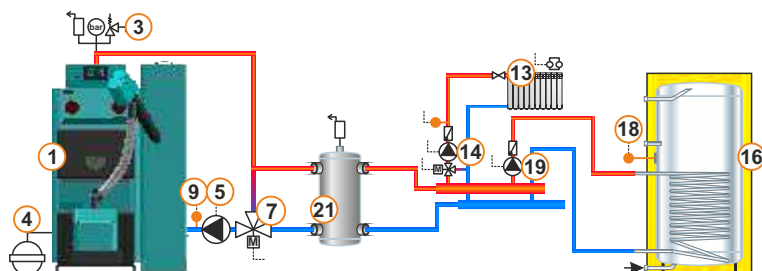
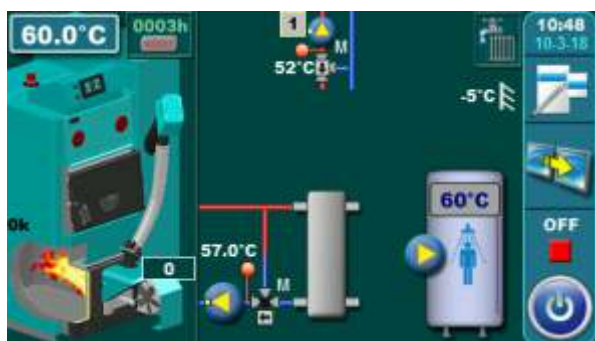

**Temperatures:** Tboiler: 80°C (70-90°C)  
 dTboiler: 10°C (5-15°C)  
 Tdhw: 50°C (10-70°C)  
 dTdhw: 5°C (5-50°C)

1. Circuit:  
 Const. temp. day: 60°C (20-90°C)  
 Const. temp. night: 60°C (20-90°C)  
 Day room temp.: 20°C (5-30°C)  
 Night room temp.: 20°C (5-30°C)

13.45. CONFIGURATION D-2-0

EKO-CK P

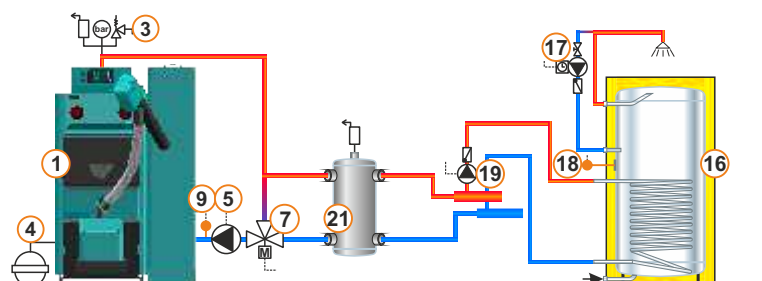
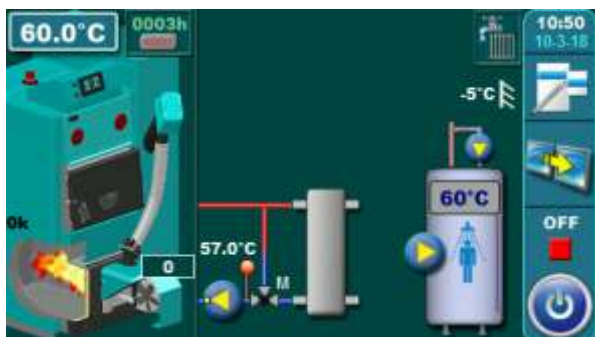

**Temperatures:** Tboiler: 80°C (70-90°C)  
 dTboiler: 10°C (5-15°C)  
 Tboiler: 50°C (10-70°C)  
 dTboiler: 5°C (5-50°C)

13.46. CONFIGURATION D-2-1

EKO-CK P

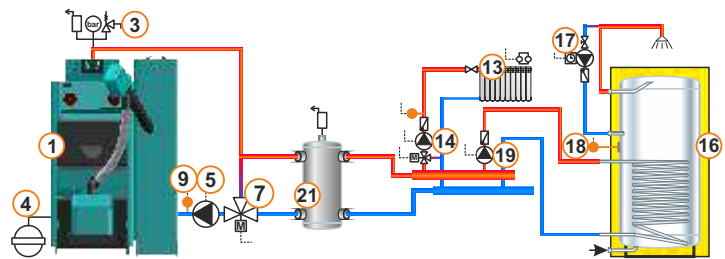
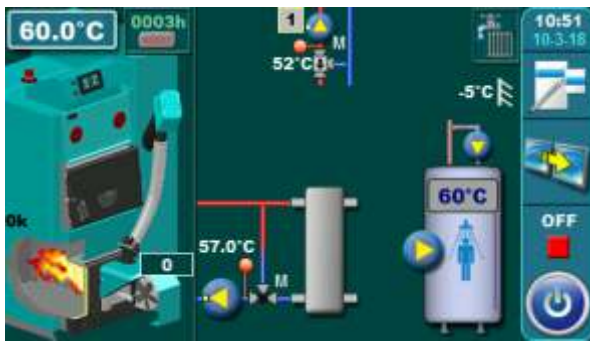

**Temperatures:** Tboiler: 80°C (70-90°C)  
 dTboiler: 10°C (5-15°C)  
 Tdhw: 50°C (10-70°C)  
 dTdhw: 5°C (5-50°C)

1. Circuit:  
 Const. temp. day: 60°C (20-90°C)  
 Const. temp. night: 60°C (20-90°C)  
 Day room temp.: 20°C (5-30°C)  
 Night room temp.: 20°C (5-30°C)

13.47. CONFIGURATION D-7-0

EKO-CKB P

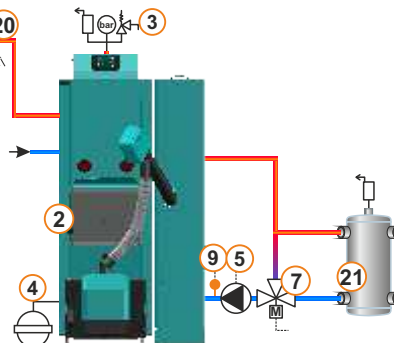
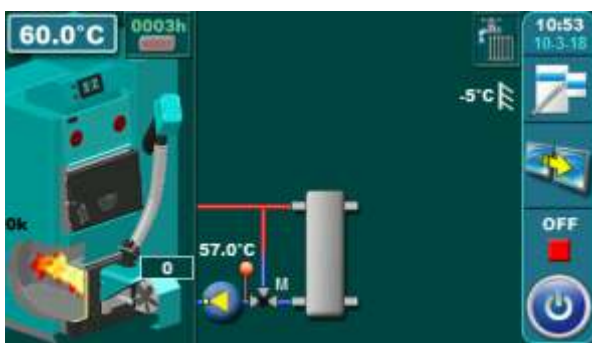

**Temperatures:** Tboiler:  
 - Mode: -> Heating+DHW: 80°C (70-90°C)  
 -> DHW: 70°C (70-80°C)  
 dTboiler:  
 - Mode: - Heating+DHW: 10°C (5-15°C)  
 - DHW: 10°C (5-10°C)

Tdhw:  
 - Mode: - Heating+DHW: Tdhw=Tboiler=80°C  
 - DHW: Tdhw=Tboiler=70°C  
 dTdhw:  
 - Mode: - Heating+DHW: 15°C (10-40°C)  
 - DHW: 15°C (10-40°C)

13.48. CONFIGURATION D-7-1

EKO-CKB P

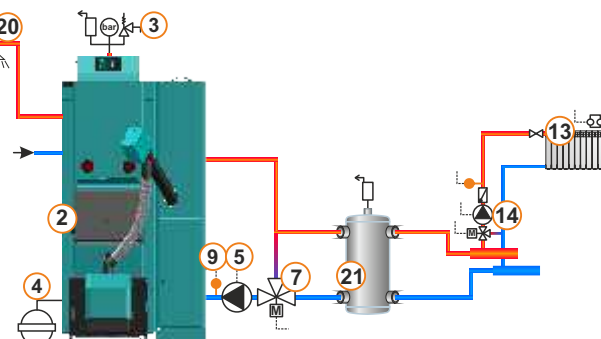
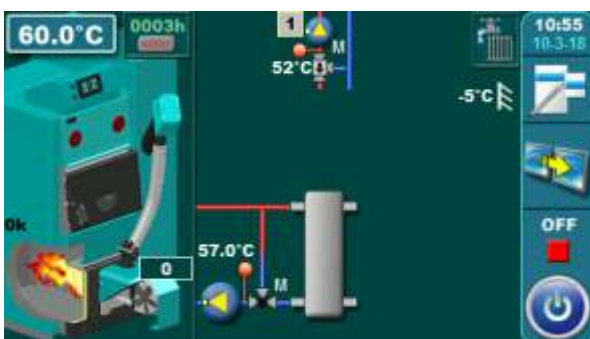

**Temperatures:** Tboiler:  
 - Mode: -> Heating+DHW: 80°C (70-90°C)  
 -> DHW: 70°C (70-80°C)  
 dTboiler:  
 - Mode: - Heating+DHW: 10°C (5-15°C)  
 - DHW: 10°C (5-10°C)

Tdhw:  
 - Mode: - Heating+DHW: Tdhw=Tboiler=80°C  
 - DHW: Tdhw=Tboiler=70°C  
 dTdhw:  
 - Mode: - Heating+DHW: 15°C (10-40°C)  
 - DHW: 15°C (10-40°C)

1. Circuit:  
 Const. temp. day: 60°C (20-90°C)  
 Const. temp. night: 60°C (20-90°C)  
 Day room temp.: 20°C (5-30°C)  
 Night room temp.: 20°C (5-30°C)

13.49. CONFIGURATION D-8-0

EKO-CKB P

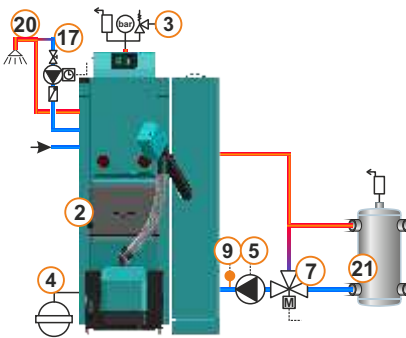
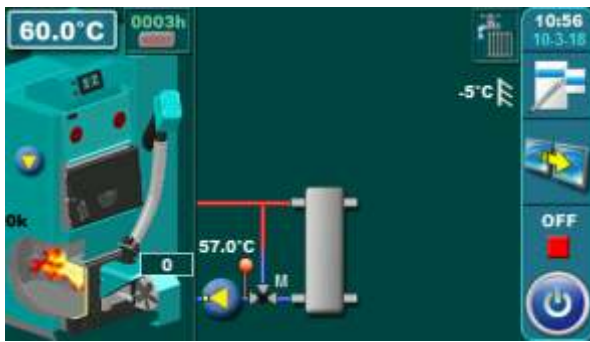

**Temperatures:** Tboiler:  
 - Mode: -> Heating+DHW: 80°C (70-90°C)  
 -> DHW: 70°C (70-80°C)  
 dTboiler:  
 - Mode: - Heating+DHW: 10°C (5-15°C)  
 - DHW: 10°C (5-10°C)

Tdhw:  
 - Mode: - Heating+DHW: Tdhw=Tboiler=80°C  
 - DHW: Tdhw=Tboiler=70°C  
 dTdhw:  
 - Mode: - Heating+DHW: 15°C (10-40°C)  
 - DHW: 15°C (10-40°C)

13.50. CONFIGURATION D-8-1

EKO-CKB P

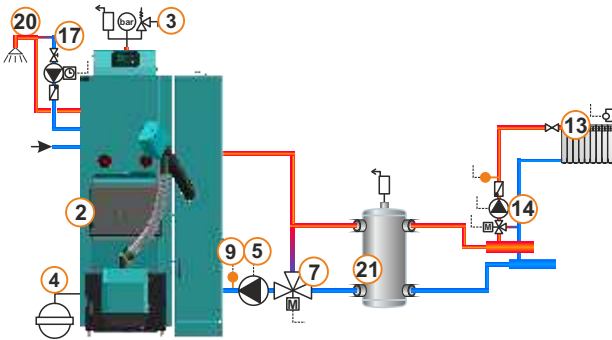
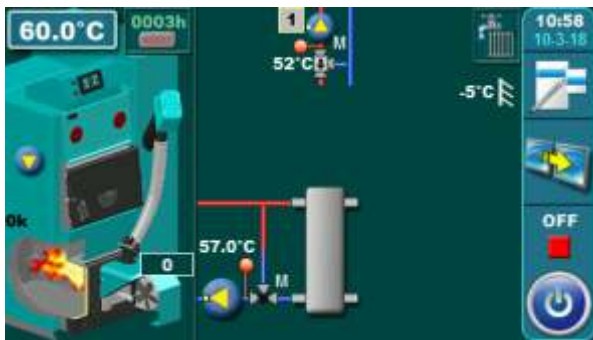

**Temperatures:** Tboiler:  
 - Mode: -> Heating+DHW: 80°C (70-90°C)  
 -> DHW: 70°C (70-80°C)  
 dTboiler:  
 - Mode: - Heating+DHW: 10°C (5-15°C)  
 - DHW: 10°C (5-10°C)

Tdhw:  
 - Mode: - Heating+DHW: Tdhw=Tboiler=80°C  
 - DHW: Tdhw=Tboiler=70°C  
 dTdhw:  
 - Mode: - Heating+DHW: 15°C (10-40°C)  
 - DHW: 15°C (10-40°C)

1. Circuit:  
 Const. temp. day: 60°C (20-90°C)  
 Const. temp. night: 60°C (20-90°C)  
 Day room temp.: 20°C (5-30°C)  
 Night room temp.: 20°C (5-30°C)

13.51. CONFIGURATION E-0-0

EKO-CK P

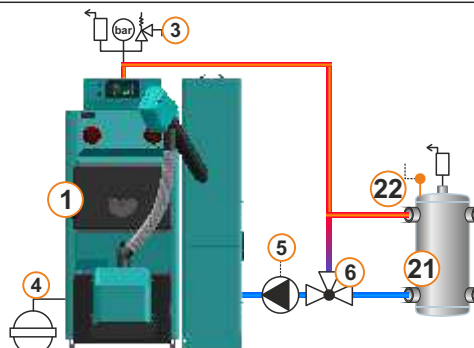
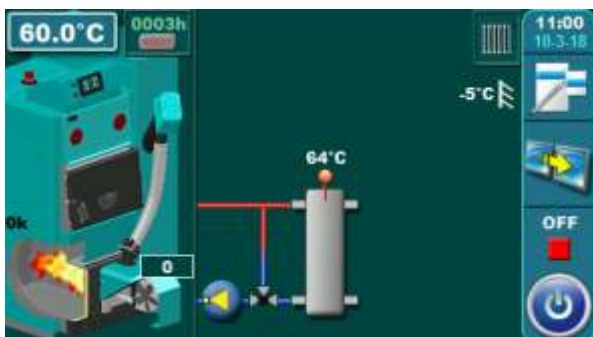

**Temperatures:** Tboiler: 80°C (75-90°C)  
 dTboiler: 10°C (5-15°C)  
 Tcro: 75°C (70-80°C)

13.52. CONFIGURATION E-0-1

EKO-CK P

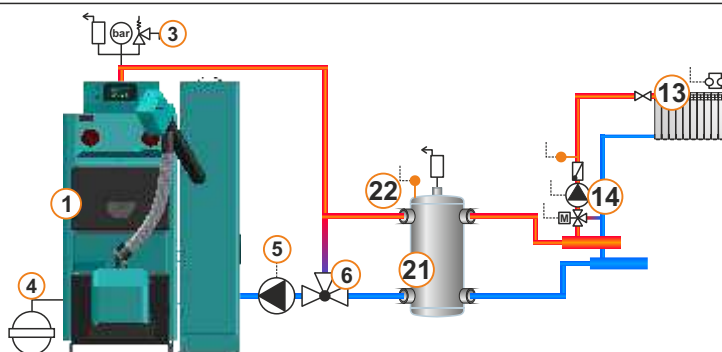
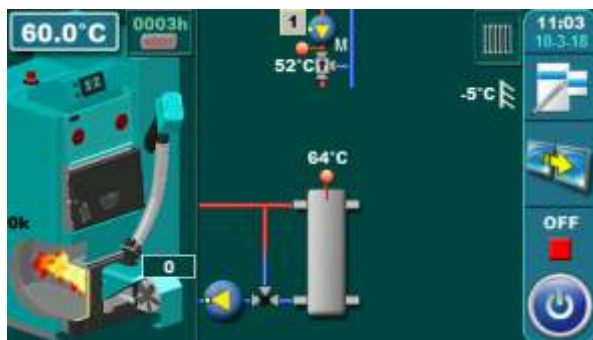

**Temperatures:** Tboiler: 80°C (75-90°C)  
dTboiler: 10°C (5-15°C)  
Tcro: 75°C (70-80°C)

1. Circuit:  
Const. temp. day: 60°C (20-90°C)  
Const. temp. night: 60°C (20-90°C)  
Day room temp.: 20°C (5-30°C)  
Night room temp.: 20°C (5-30°C)

13.53. CONFIGURATION E-0-2

EKO-CK P

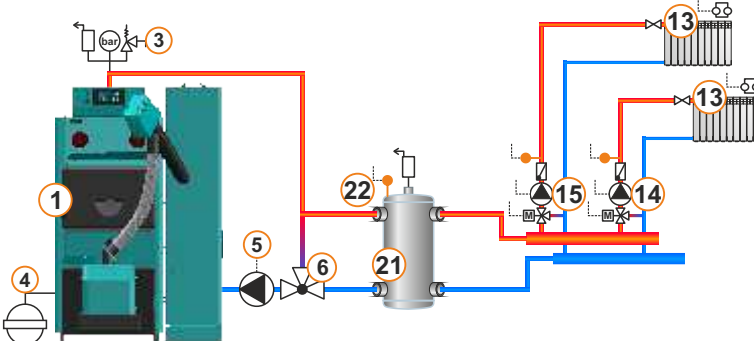
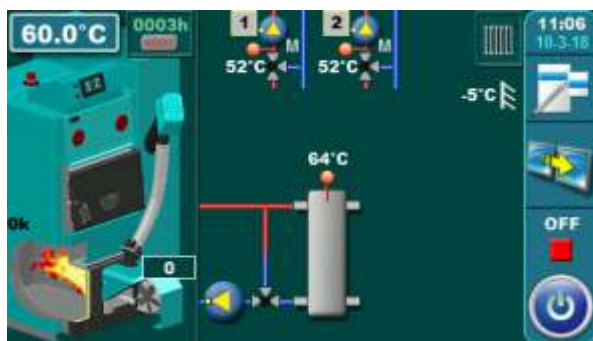

**Temperatures:** Tboiler: 80°C (75-90°C)  
dTboiler: 10°C (5-15°C)  
Tcro: 75°C (70-80°C)

1. Circuit, 2. Circuit:  
Const. temp. day: 60°C (20-90°C)  
Const. temp. night: 60°C (20-90°C)  
Day room temp.: 20°C (5-30°C)  
Night room temp.: 20°C (5-30°C)

13.54. CONFIGURATION E-1-0

EKO-CK P

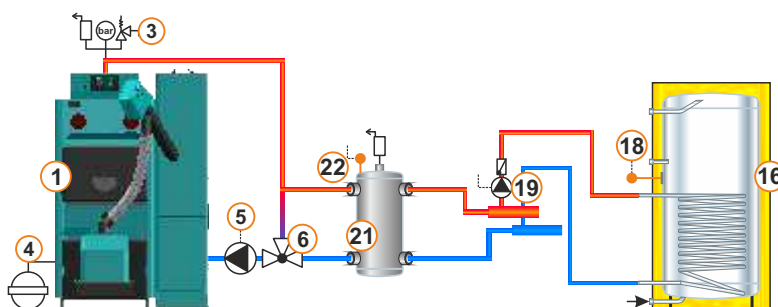
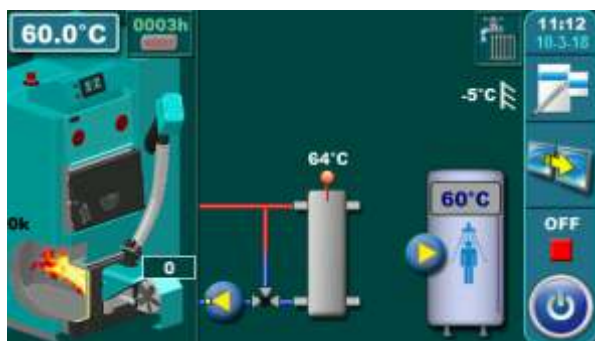

**Temperatures:** Tboiler: 80°C (75-90°C)  
dTboiler: 10°C (5-15°C)  
Tcro: 75°C (70-80°C)  
Tdhw: 50°C (10-73°C)  
dTdhw: 5°C (5-50°C)

13.55. CONFIGURATION E-1-1

EKO-CK P

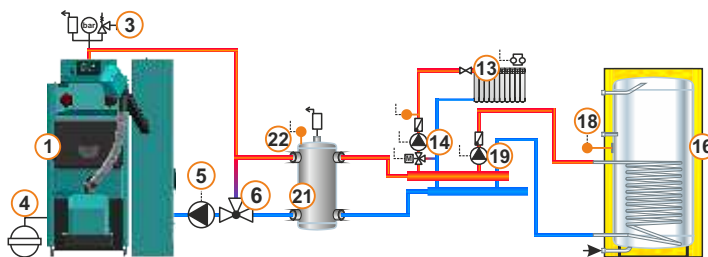
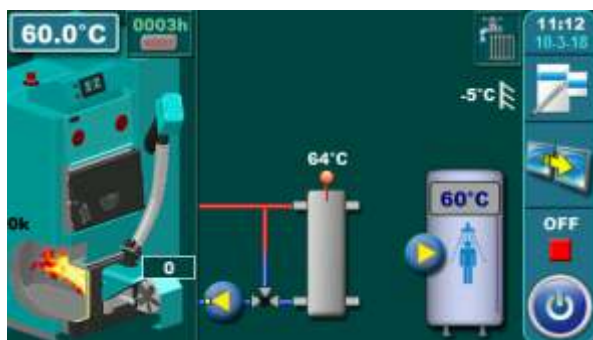

**Temperatures:** Tboiler: 80°C (75-90°C)  
 dTboiler: 10°C (5-15°C)  
 Tcro: 75°C (70-80°C)  
 Tdhw: 50°C (10-73°C)  
 dTdhw: 5°C (5-50°C)

1. Circuit:  
 Const. temp. day: 60°C (20-90°C)  
 Const. temp. night: 60°C (20-90°C)  
 Day room temp.: 20°C (5-30°C)  
 Night room temp.: 20°C (5-30°C)

13.56. CONFIGURATION E-1-2

EKO-CK P

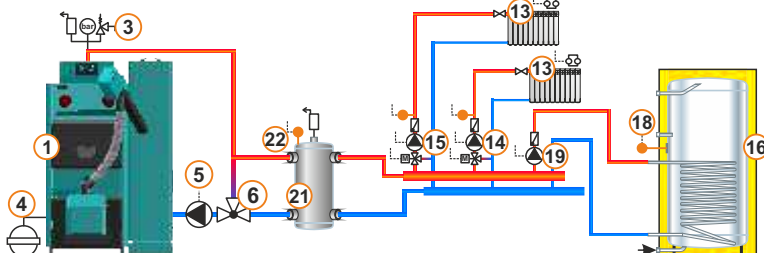
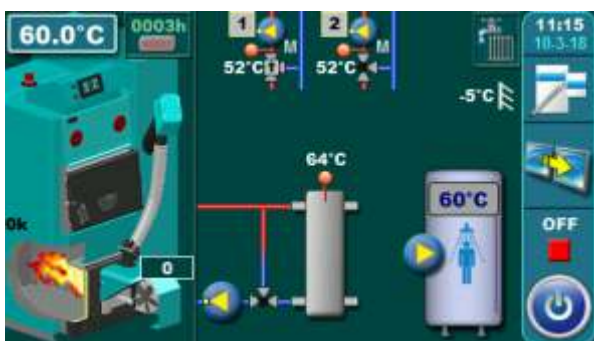

**Temperatures:** Tboiler: 80°C (75-90°C)  
 dTboiler: 10°C (5-15°C)  
 Tcro: 75°C (70-80°C)  
 Tdhw: 50°C (10-73°C)  
 dTdhw: 5°C (5-50°C)

1. Circuit, 2. Circuit:  
 Const. temp. day: 60°C (20-90°C)  
 Const. temp. night: 60°C (20-90°C)  
 Day room temp.: 20°C (5-30°C)  
 Night room temp.: 20°C (5-30°C)

13.57. CONFIGURATION E-2-0

EKO-CK P

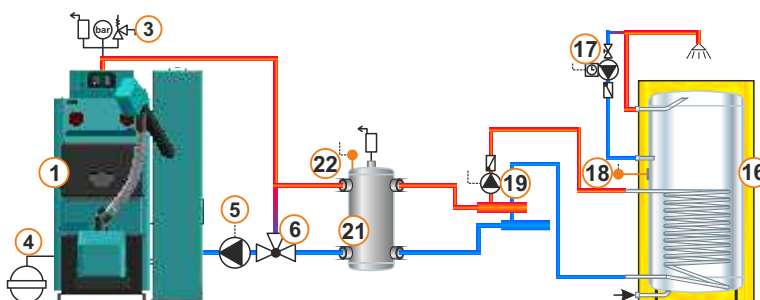
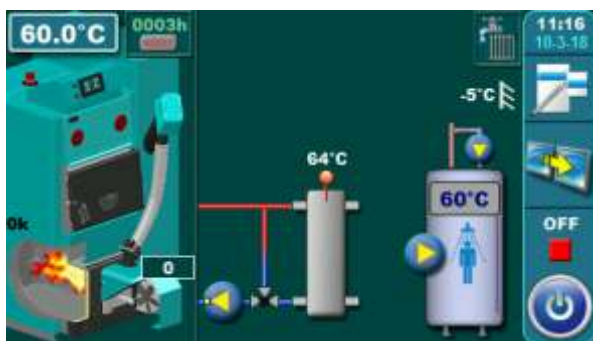

**Temperatures:** Tboiler: 80°C (75-90°C)  
 dTboiler: 10°C (5-15°C)  
 Tcro: 75°C (70-80°C)  
 Tdhw: 50°C (10-73°C)  
 dTdhw: 5°C (5-50°C)

13.58. CONFIGURATION E-2-1

EKO-CK P

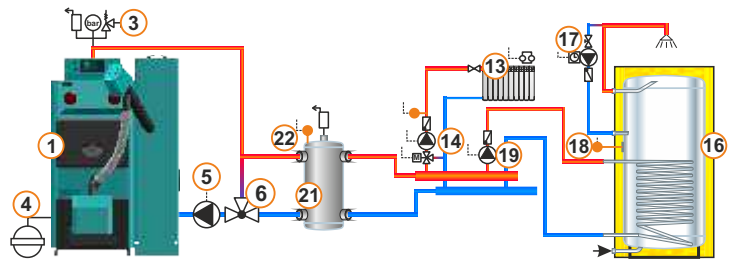
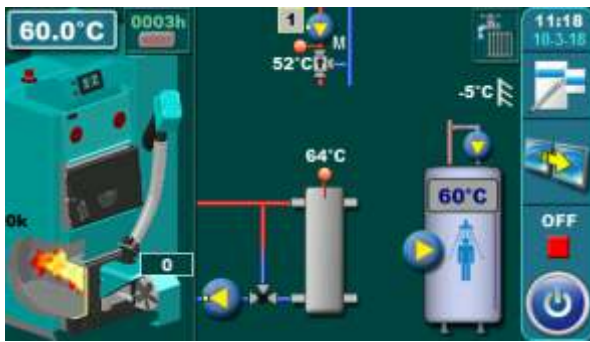

**Temperatures:** Tboiler: 80°C (75-90°C)  
 dTboiler: 10°C (5-15°C)  
 Tcro: 75°C (70-80°C)  
 Tdhw: 50°C (10-73°C)  
 dTdhw: 5°C (5-50°C)

1. Circuit:  
 Const. temp. day: 60°C (20-90°C)  
 Const. temp. night: 60°C (20-90°C)  
 Day room temp.: 20°C (5-30°C)  
 Night room temp.: 20°C (5-30°C)

13.59. CONFIGURATION E-2-2

EKO-CK P

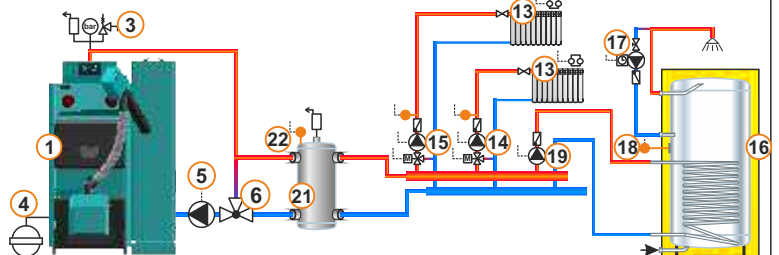
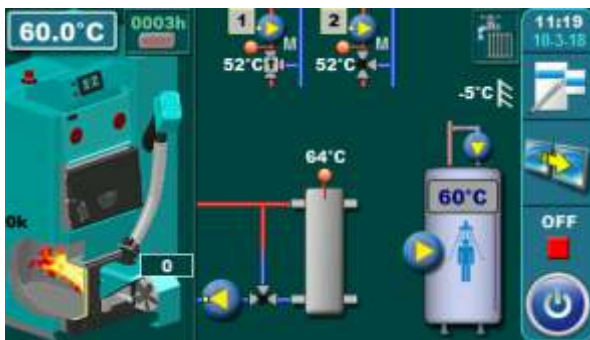

**Temperatures:** Tboiler: 80°C (75-90°C)  
 dTboiler: 10°C (5-15°C)  
 Tcro: 75°C (70-80°C)  
 Tdhw: 50°C (10-73°C)  
 dTdhw: 5°C (5-50°C)

1. Circuit, 2. Circuit:  
 Const. temp. day: 60°C (20-90°C)  
 Const. temp. night: 60°C (20-90°C)  
 Day room temp.: 20°C (5-30°C)  
 Night room temp.: 20°C (5-30°C)

13.60. CONFIGURATION E-7-0

EKO-CKB P

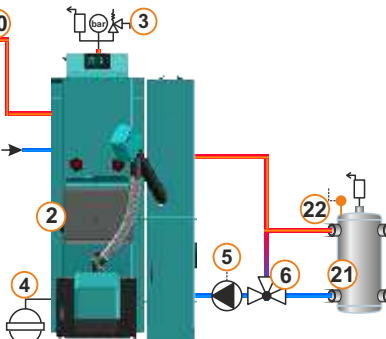
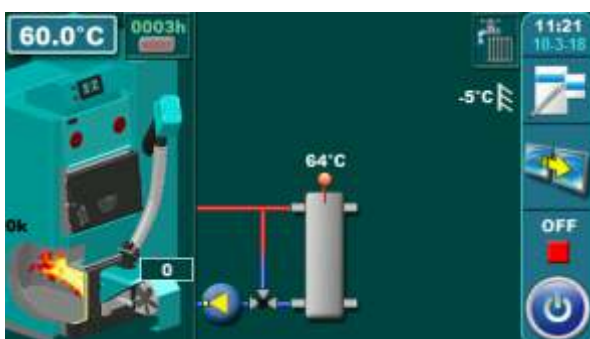

**Temperatures:** Tboiler:  
 - Mode: -> Heating+DHW: 80°C (75-90°C)  
 -> DHW: 70°C (75-80°C)  
 dTboiler:  
 - Mode: - Heating+DHW: 10°C (5-15°C)  
 - DHW: 10°C (5-10°C)

Tdhw:  
 - Mode: - Heating+DHW: Tdhw=Tboiler=80°C  
 - DHW: Tdhw=Tboiler=70°C  
 dTdhw:  
 - Mode: - Heating+DHW: 15°C (10-40°C)  
 - DHW: 15°C (10-40°C)

Tcro: 75°C (70-80°C)

13.61. CONFIGURATION E-7-1

EKO-CKB P

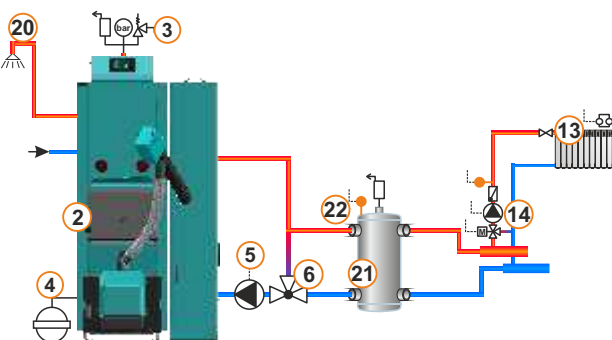
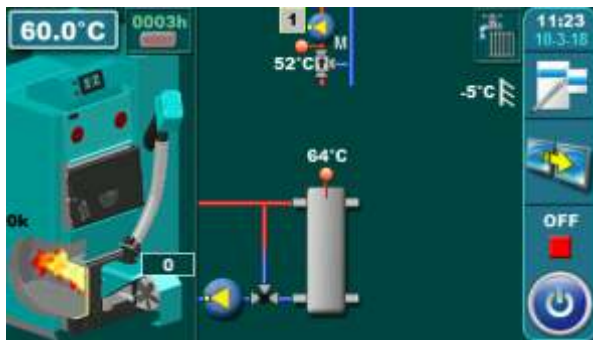

**Temperatures:** Tboiler:  
 - Mode: -> Heating+DHW: 80°C (75-90°C)  
 -> DHW: 70°C (75-80°C)  
 dTboiler:  
 - Mode: - Heating+DHW: 10°C (5-15°C)  
 - DHW: 10°C (5-10°C)

Tdhw:  
 - Mode: - Heating+DHW: Tdhw=Tboiler=80°C  
 - DHW: Tdhw=Tboiler=70°C  
 dTdhw:  
 - Mode: - Heating+DHW: 15°C (10-40°C)  
 - DHW: 15°C (10-40°C)

Tcro: 75°C (70-80°C)

Circuit 1:  
 Const. temp. day: 60°C (20-90°C)  
 Const. temp. night: 60°C (20-90°C)  
 Day room temp.: 20°C (5-30°C)  
 Night room temp.: 20°C (5-30°C)

13.62. CONFIGURATION E-7-2

EKO-CKB P

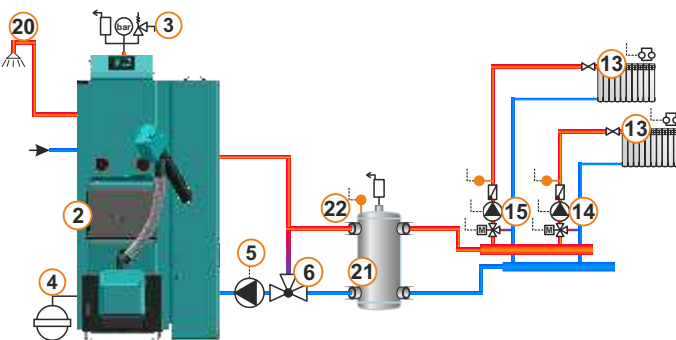
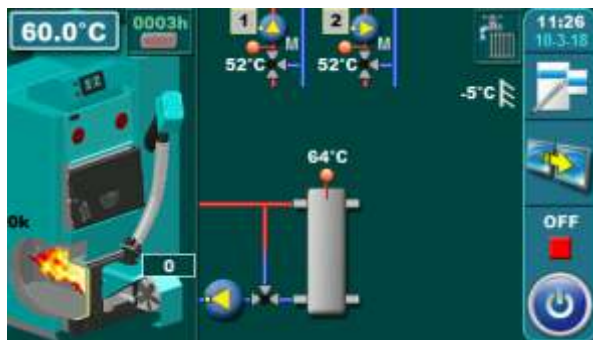

**Temperatures:** Tboiler:  
 - Mode: -> Heating+DHW: 80°C (75-90°C)  
 -> DHW: 70°C (75-80°C)  
 dTboiler:  
 - Mode: - Heating+DHW: 10°C (5-15°C)  
 - DHW: 10°C (5-10°C)

Tdhw:  
 - Mode: - Heating+DHW: Tdhw=Tboiler=80°C  
 - DHW: Tdhw=Tboiler=70°C  
 dTdhw:  
 - Mode: - Heating+DHW: 15°C (10-40°C)  
 - DHW: 15°C (10-40°C)

Tcro: 75°C (70-80°C)

Circuit 1, Circuit 2:  
 Const. temp. day: 60°C (20-90°C)  
 Const. temp. night: 60°C (20-90°C)  
 Day room temp.: 20°C (5-30°C)  
 Night room temp.: 20°C (5-30°C)

13.63. CONFIGURATION E-8-0

EKO-CKB P

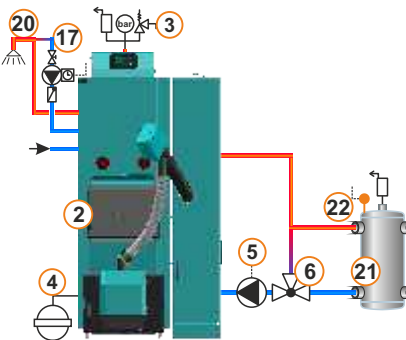
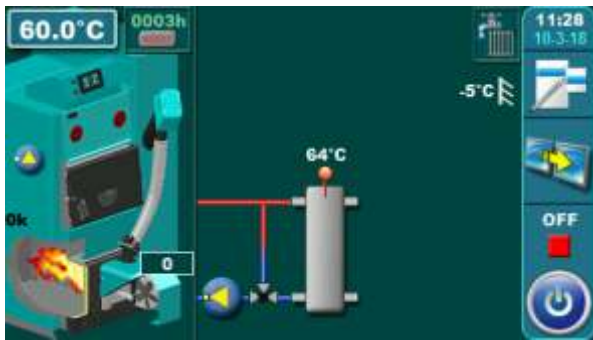

**Temperatures:** Tboiler:  
 - Mode: -> Heating+DHW: 80°C (75-90°C)  
 -> DHW: 70°C (75-80°C)  
 dTboiler:  
 - Mode: - Heating+DHW: 10°C (5-15°C)  
 - DHW: 10°C (5-10°C)

Tdhw:  
 - Mode: - Heating+DHW: Tdhw=Tboiler=80°C  
 - DHW: Tdhw=Tboiler=70°C  
 dTdhw:  
 - Mode: - Heating+DHW: 15°C (10-40°C)  
 - DHW: 15°C (10-40°C)

Tcro: 75°C (70-80°C)

13.64. CONFIGURATION E-8-1

EKO-CKB P

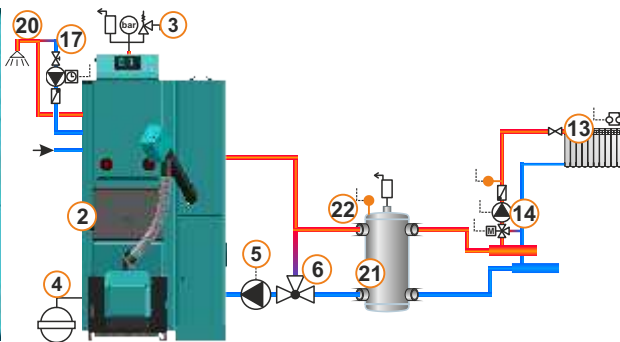
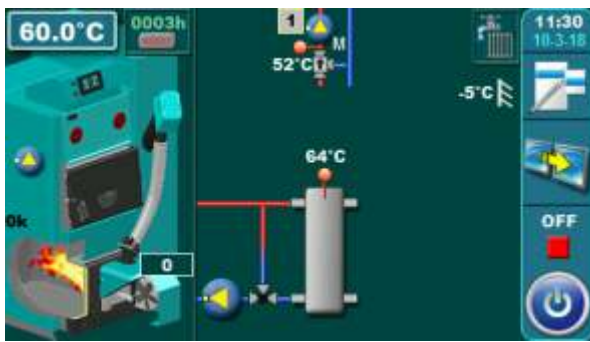

**Temperatures:** Tboiler:  
 - Mode: -> Heating+DHW: 80°C (75-90°C)  
 -> DHW: 70°C (75-80°C)  
 dTboiler:  
 - Mode: - Heating+DHW: 10°C (5-15°C)  
 - DHW: 10°C (5-10°C)

Tdhw:  
 - Mode: - Heating+DHW: Tdhw=Tboiler=80°C  
 - DHW: Tdhw=Tboiler=70°C  
 dTdhw:  
 - Mode: - Heating+DHW: 15°C (10-40°C)  
 - DHW: 15°C (10-40°C)

Tcro: 75°C (70-80°C)

Circuit 1:  
 Const. temp. day: 60°C (20-90°C)  
 Const. temp. night: 60°C (20-90°C)  
 Day room temp.: 20°C (5-30°C)  
 Night room temp.: 20°C (5-30°C)

13.65. CONFIGURATION E-8-2

EKO-CKB P

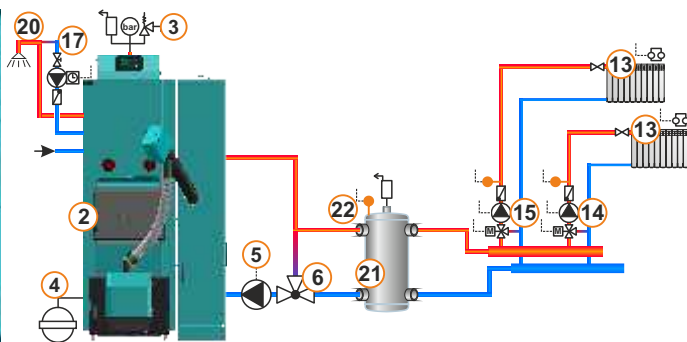
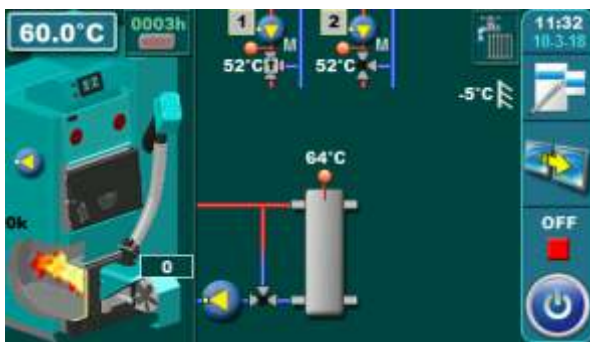

**Temperatures:** Tboiler:  
 - Mode: -> Heating+DHW: 80°C (75-90°C)  
 -> DHW: 70°C (75-80°C)  
 dTboiler:  
 - Mode: - Heating+DHW: 10°C (5-15°C)  
 - DHW: 10°C (5-10°C)

Tdhw:  
 - Mode: - Heating+DHW: Tdhw=Tboiler=80°C  
 - DHW: Tdhw=Tboiler=70°C  
 dTdhw:  
 - Mode: - Heating+DHW: 15°C (10-40°C)  
 - DHW: 15°C (10-40°C)

Tcro: 75°C (70-80°C)

Circuit 1, Circuit 2:  
 Const. temp. day: 60°C (20-90°C)  
 Const. temp. night: 60°C (20-90°C)  
 Day room temp.: 20°C (5-30°C)  
 Night room temp.: 20°C (5-30°C)

13.66. CONFIGURATION F-0-0

EKO-CK P

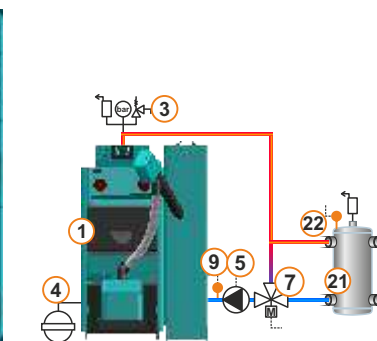
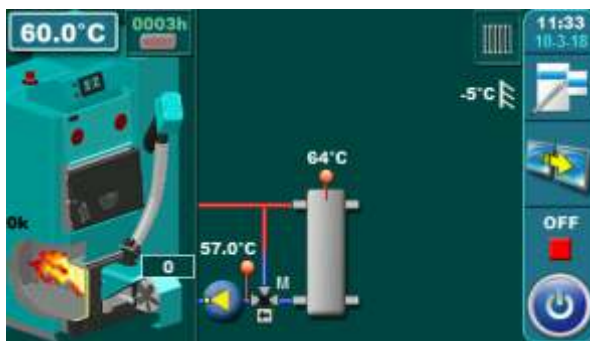

**Temperatures:** Tboiler: 80°C (75-90°C)  
 dTboiler: 10°C (5-15°C)  
 Tcro: 75°C (70-80°C)

13.67. CONFIGURATION F-0-1

EKO-CK P

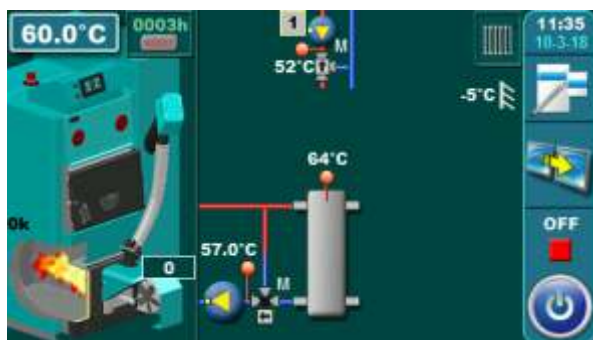

**Temperatures:** Tboiler: 80°C (75-90°C)  
dTboiler: 10°C (5-15°C)  
Tcro: 75°C (70-80°C)

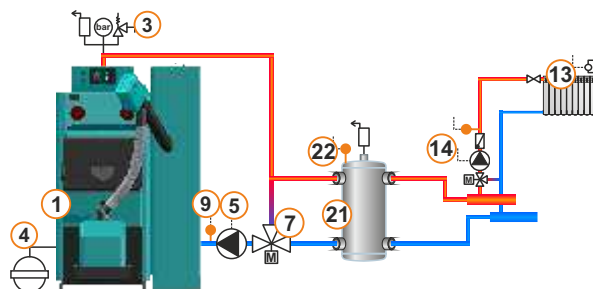

Circuit 1:  
Const. temp. day: 60°C (20-90°C)  
Const. temp. night: 60°C (20-90°C)  
Day room temp.: 20°C (5-30°C)  
Night room temp.: 20°C (5-30°C)

13.68. CONFIGURATION F-1-0

EKO-CK P

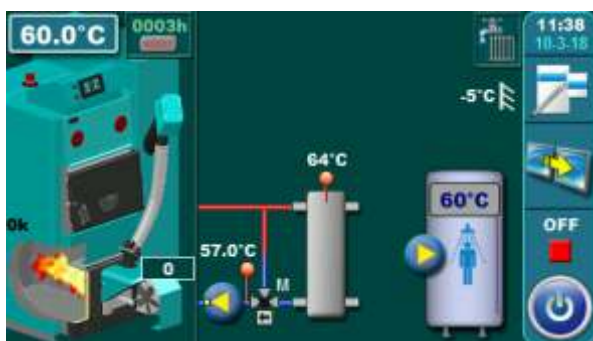

**Temperatures:** Tboiler: 80°C (75-90°C)  
dTboiler: 10°C (5-15°C)  
Tcro: 75°C (70-80°C)  
Tdhw: 50°C (10-73°C)  
dTdhw: 5°C (5-50°C)

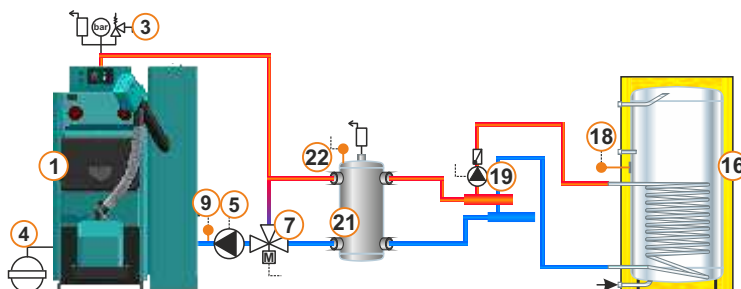

13.69. CONFIGURATION F-1-1

EKO-CK P

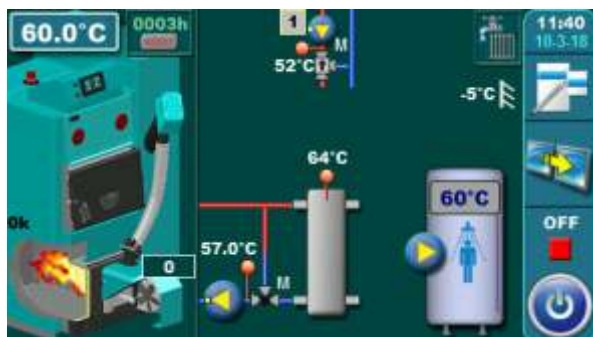

**Temperatures:** Tboiler: 80°C (75-90°C)  
dTboiler: 10°C (5-15°C)  
Tcro: 75°C (70-80°C)  
Tdhw: 50°C (10-73°C)  
dTdhw: 5°C (5-50°C)

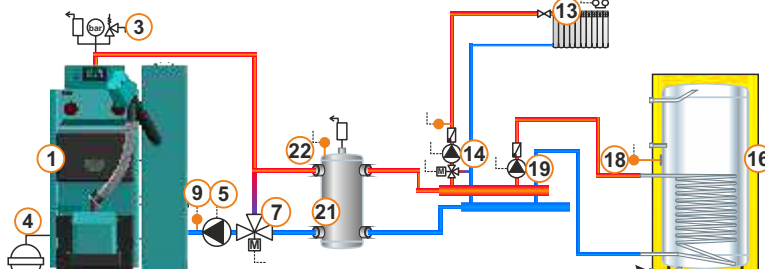

Circuit 1:  
Const. temp. day: 60°C (20-90°C)  
Const. temp. night: 60°C (20-90°C)  
Day room temp.: 20°C (5-30°C)  
Night room temp.: 20°C (5-30°C)

13.70. CONFIGURATION F-2-0

EKO-CK P

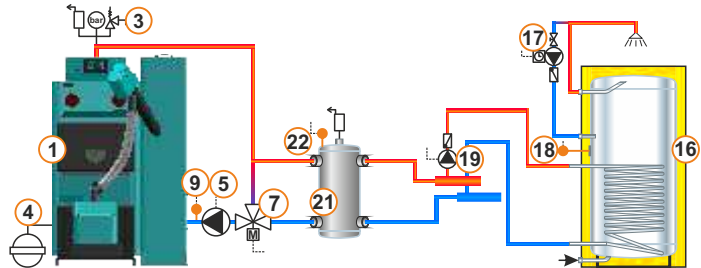
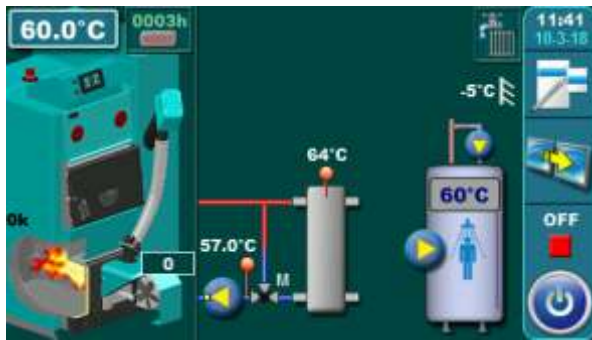

**Temperatures:** Tboiler: 80°C (75-90°C)  
 dTboiler: 10°C (5-15°C)  
 Tcro: 75°C (70-80°C)  
 Tdhw: 50°C (10-73°C)  
 dTdhw: 5°C (5-50°C)

13.71. CONFIGURATION F-2-1

EKO-CK P

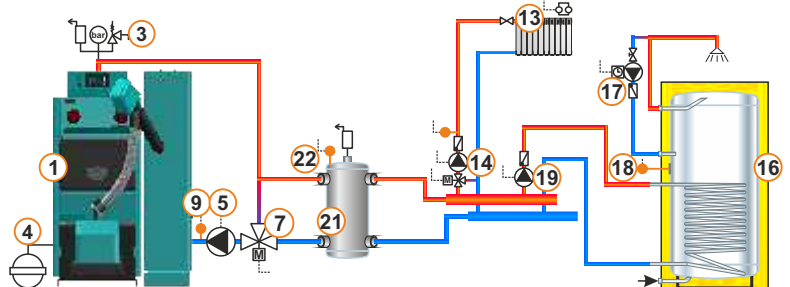
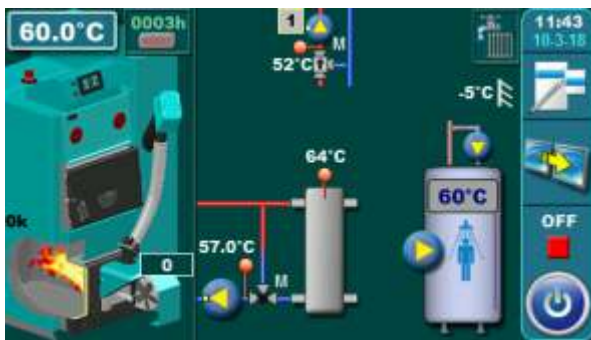

**Temperatures:** Tboiler: 80°C (75-90°C)  
 dTboiler: 10°C (5-15°C)  
 Tcro: 75°C (70-80°C)  
 Tdhw: 50°C (10-73°C)  
 dTdhw: 5°C (5-50°C)

Circuit 1:  
 Const. temp. day: 60°C (20-90°C)  
 Const. temp. night: 60°C (20-90°C)  
 Day room temp.: 20°C (5-30°C)  
 Night room temp.: 20°C (5-30°C)

13.72. CONFIGURATION F-7-0

EKO-CKB P

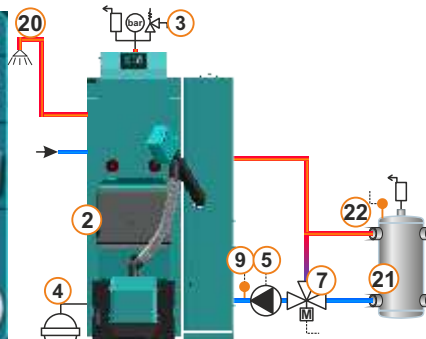
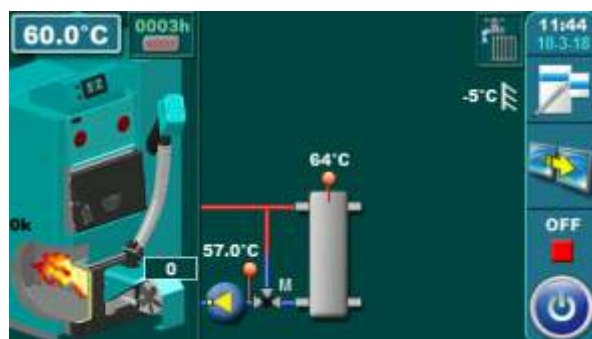

**Temperatures:** Tboiler:  
 - Mode: -> Heating+DHW: 80°C (75-90°C)  
 -> DHW: 70°C (75-80°C)  
 dTboiler:  
 - Mode: - Heating+DHW: 10°C (5-15°C)  
 - DHW: 10°C (5-10°C)

Tdhw:  
 - Mode: - Heating+DHW: Tdhw=Tboiler=80°C  
 - DHW: Tdhw=Tboiler=70°C  
 dTdhw:  
 - Mode: - Heating+DHW: 15°C (10-40°C)  
 - DHW: 15°C (10-40°C)

Tcro: 75°C (70-80°C)

13.73. CONFIGURATION F-7-1

EKO-CKB P

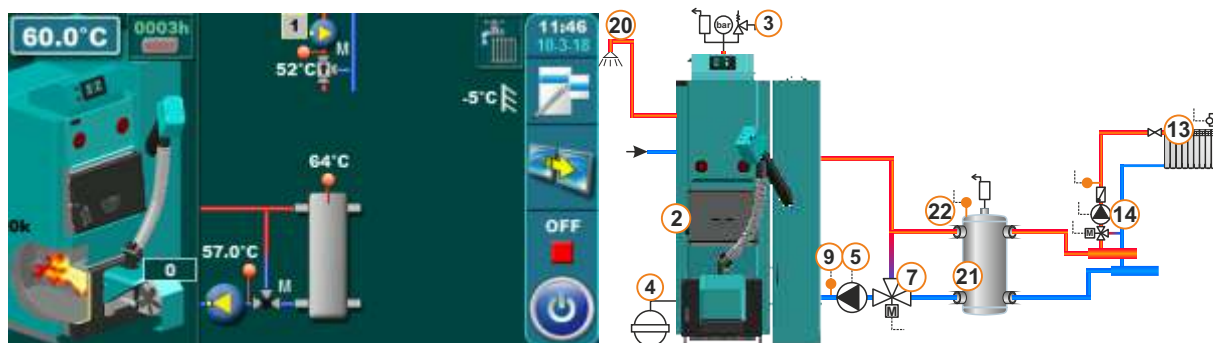

**Temperatures:**

**Tboiler:**  
 - Mode: -> Heating+DHW: 80°C (75-90°C)  
 -> DHW: 70°C (75-80°C)  
**dTboiler:**  
 - Mode: - Heating+DHW: 10°C (5-15°C)  
 - DHW: 10°C (5-10°C)

**Tdhw:**  
 - Mode: - Heating+DHW: Tdhw=Tboiler=80°C  
 - DHW: Tdhw=Tboiler=70°C  
**dTdhw:**  
 - Mode: - Heating+DHW: 15°C (10-40°C)  
 - DHW: 15°C (10-40°C)

Tcرو: 75°C (70-80°C)

**Circuit 1:**  
 Const. temp. day: 60°C (20-90°C)  
 Const. temp. night: 60°C (20-90°C)  
 Day room temp.: 20°C (5-30°C)  
 Night room temp.: 20°C (5-30°C)

13.74. CONFIGURATION F-8-0

EKO-CKB P

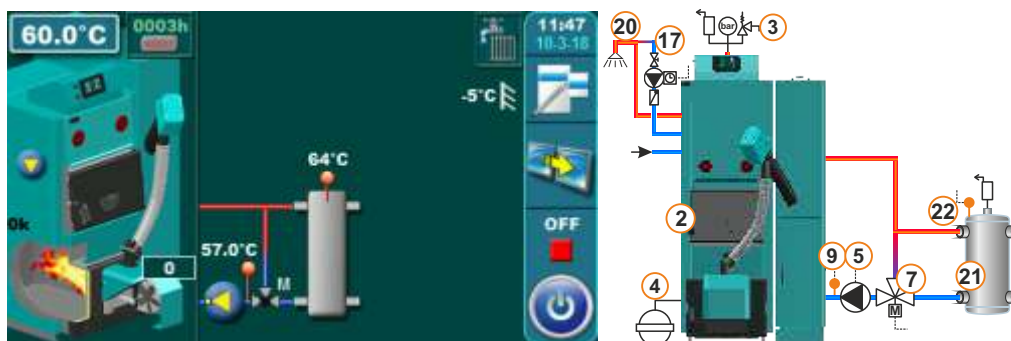

**Temperatures:**

**Tboiler:**  
 - Mode: -> Heating+DHW: 80°C (75-90°C)  
 -> DHW: 70°C (75-80°C)  
**dTboiler:**  
 - Mode: - Heating+DHW: 10°C (5-15°C)  
 - DHW: 10°C (5-10°C)

**Tdhw:**  
 - Mode: - Heating+DHW: Tdhw=Tboiler=80°C  
 - DHW: Tdhw=Tboiler=70°C  
**dTdhw:**  
 - Mode: - Heating+DHW: 15°C (10-40°C)  
 - DHW: 15°C (10-40°C)

Tcرو: 75°C (70-80°C)

13.75. CONFIGURATION F-8-1

EKO-CKB P

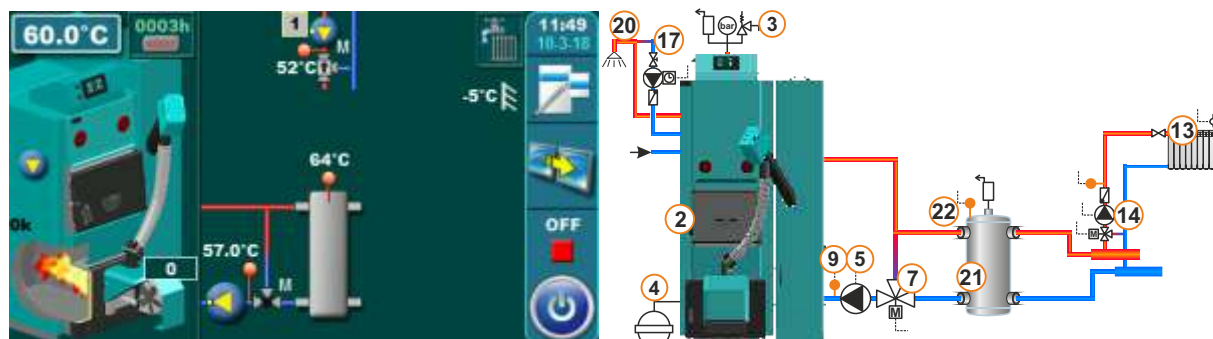

**Temperatures:**

**Tboiler:**  
 - Mode: -> Heating+DHW: 80°C (75-90°C)  
 -> DHW: 70°C (75-80°C)  
**dTboiler:**  
 - Mode: - Heating+DHW: 10°C (5-15°C)  
 - DHW: 10°C (5-10°C)

**Tdhw:**  
 - Mode: - Heating+DHW: Tdhw=Tboiler=80°C  
 - DHW: Tdhw=Tboiler=70°C  
**dTdhw:**  
 - Mode: - Heating+DHW: 15°C (10-40°C)  
 - DHW: 15°C (10-40°C)

Tcرو: 75°C (70-80°C)

**Circuit 1:**  
 Const. temp. day: 60°C (20-90°C)  
 Const. temp. night: 60°C (20-90°C)  
 Day room temp.: 20°C (5-30°C)  
 Night room temp.: 20°C (5-30°C)

13.76. CONFIGURATION H-0-0

EKO CK P

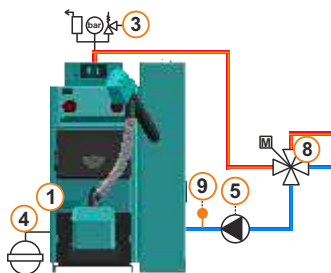
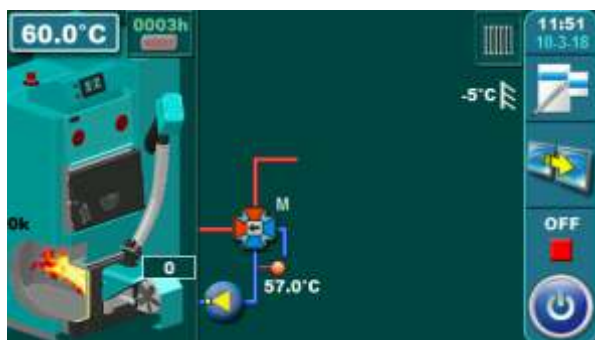

Temperatures: Tboiler: 80°C (70-90°C)  
dTboiler: 10°C (5-15°C)

13.76.1. CONFIGURATION H-0-0

\*EKO-CK P

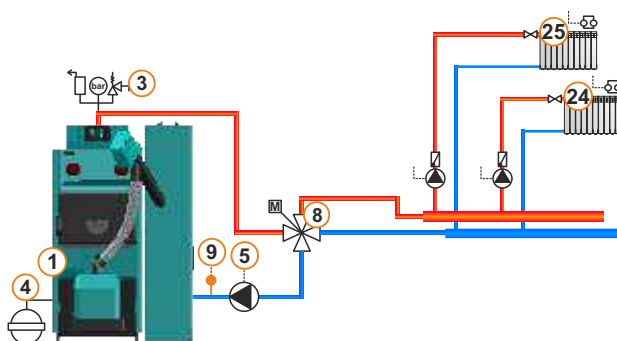
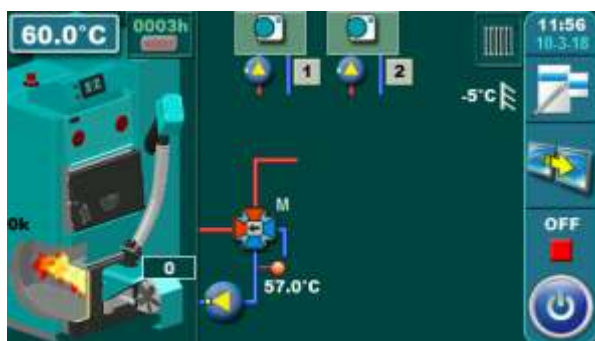

Temperatures: Tboiler: 80°C (70-90°C)  
dTboiler: 10°C (5-15°C)

\*DIRECT HEATING CIRCUITS WITH PUMPS

13.76.2. CONFIGURATION H-0-0

\*EKO-CK P

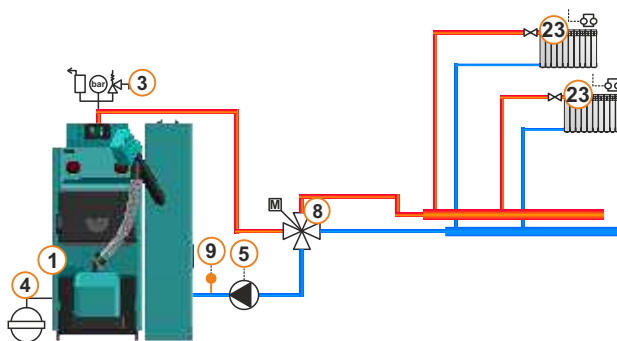
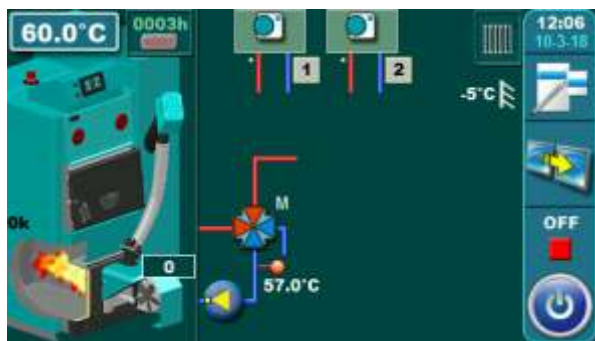

Temperatures: Tboiler: 80°C (70-90°C)  
dTboiler: 10°C (5-15°C)

\*DIRECT HEATING CIRCUITS WITHOUT PUMPS

13.77. CONFIGURATION H-0-1

EKO-CK P

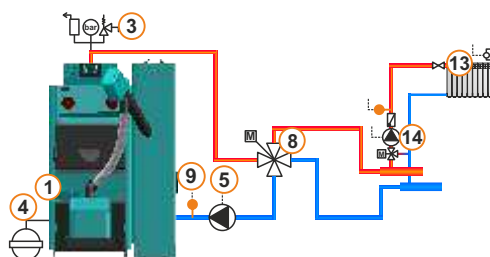
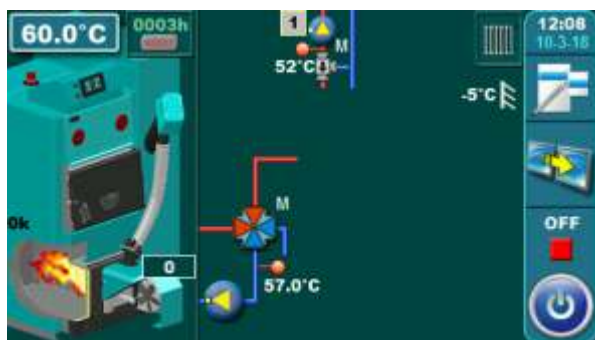

**Temperatures:** Tboiler: 80°C (70-90°C)  
dTboiler: 10°C (5-15°C)

Circuit 1:  
Const. temp. day: 60°C (20-90°C)  
Const. temp. night: 60°C (20-90°C)  
Day room temp.: 20°C (5-30°C)  
Night room temp.: 20°C (5-30°C)

13.78. CONFIGURATION H-1-0

EKO-CK P

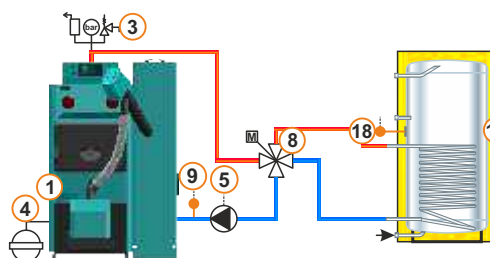
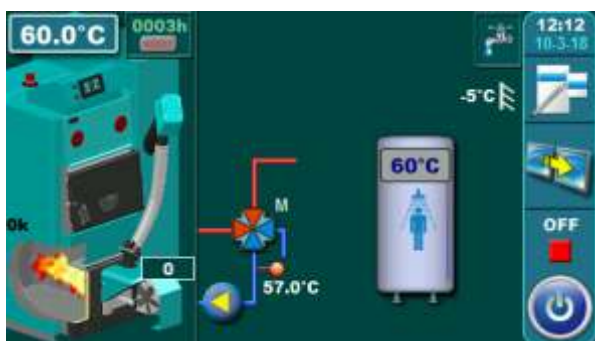

**Temperatures:** Tboiler: 80°C (70-90°C)  
dTboiler: 10°C (5-15°C)  
Tdhw: 50°C (10-70°C)  
dTdhw: 5°C (5-50°C)

13.78.1. CONFIGURATION H-1-0

\*EKO-CK P

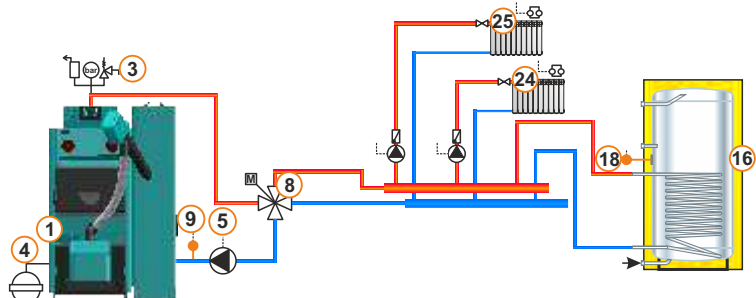
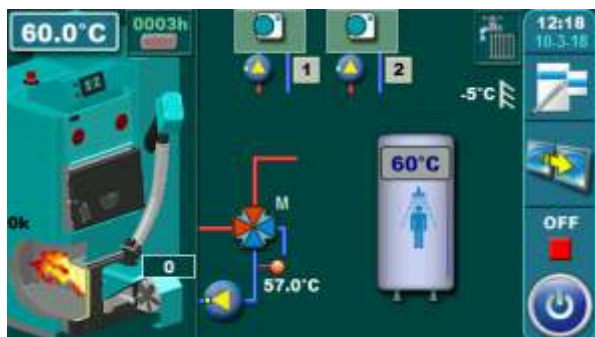

**Temperatures:** Tboiler: 80°C (70-90°C)  
dTboiler: 10°C (5-15°C)  
Tdhw: 50°C (10-70°C)  
dTdhw: 5°C (5-50°C)

\*DIRECT HEATING CIRCUITS WITH PUMPS

13.78.2. CONFIGURATION H-1-0

\*EKO-CK P

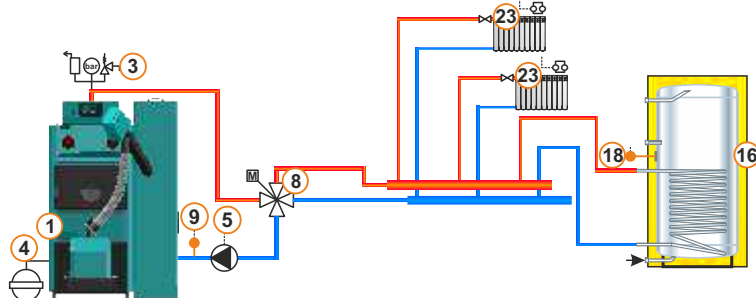
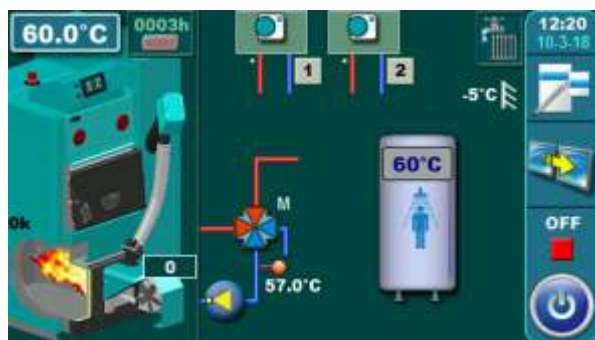

**Temperatures:** Tboiler: 80°C (70-90°C)  
 dTboiler: 10°C (5-15°C)  
 Tdhw: 50°C (10-70°C)  
 dTdhw: 5°C (5-50°C)

\*DIRECT HEATING CIRCUITS WITHOUT PUMPS

13.79. CONFIGURATION H-1-1

EKO-CK P

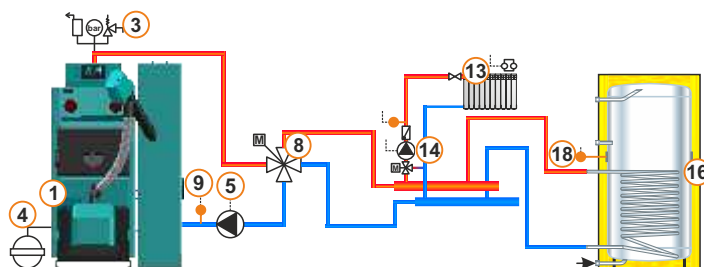
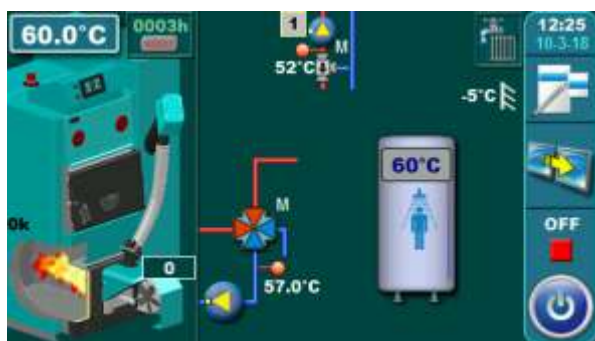

**Temperatures:** Tboiler: 80°C (70-90°C)  
 dTboiler: 10°C (5-15°C)  
 Tdhw: 50°C (10-70°C)  
 dTdhw: 5°C (5-50°C)

Circuit 1:  
 Const. temp. day: 60°C (20-90°C)  
 Const. temp. night: 60°C (20-90°C)  
 Day room temp.: 20°C (5-30°C)  
 Night room temp.: 20°C (5-30°C)

13.80. CONFIGURATION H-2-0

EKO-CK P

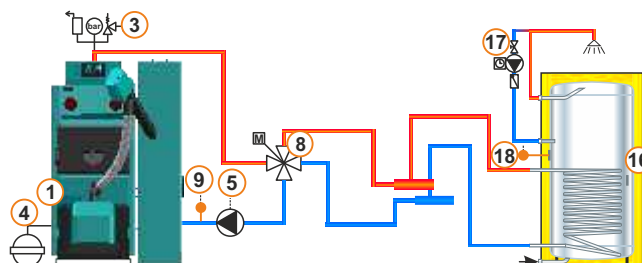
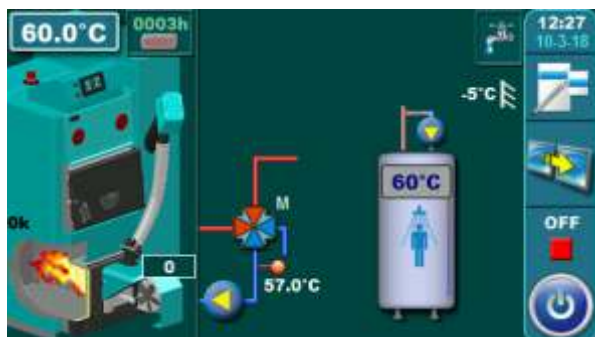

**Temperatures:** Tboiler: 80°C (70-90°C)  
 dTboiler: 10°C (5-15°C)  
 Tdhw: 50°C (10-70°C)  
 dTdhw: 5°C (5-50°C)

13.80.1. CONFIGURATION H-2-0

\*EKO-CK P

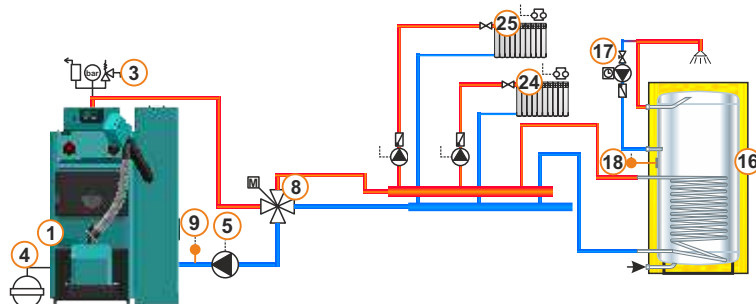
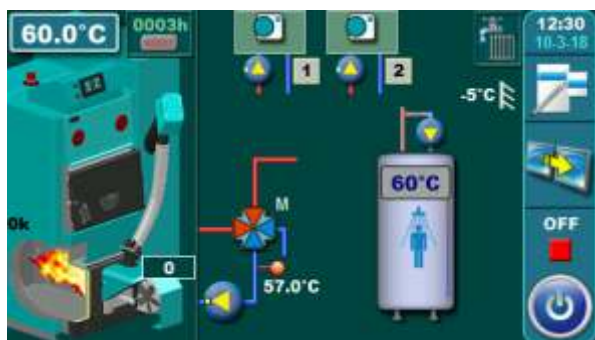

**Temperatures:** Tboiler: 80°C (70-90°C)  
 dTboiler: 10°C (5-15°C)  
 Tdhw: 50°C (10-70°C)  
 dTdhw: 5°C (5-50°C)

\*DIRECT HEATING CIRCUITS WITH PUMPS

13.80.2. CONFIGURATION H-2-0

\*EKO-CK P

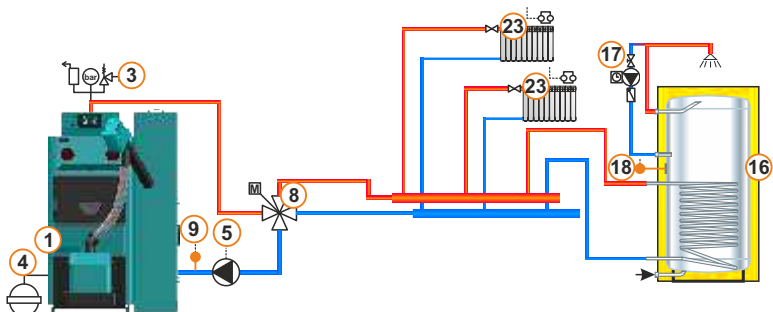
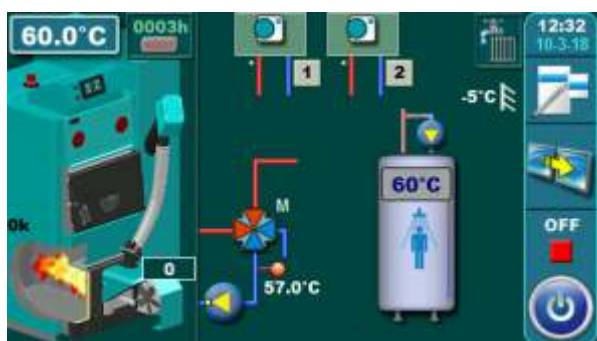

**Temperatures:** Tboiler: 80°C (70-90°C)  
 dTboiler: 10°C (5-15°C)  
 Tdhw: 50°C (10-70°C)  
 dTdhw: 5°C (5-50°C)

\*DIRECT HEATING CIRCUITS WITHOUT PUMPS

13.81. CONFIGURATION H-2-1

EKO-CK P

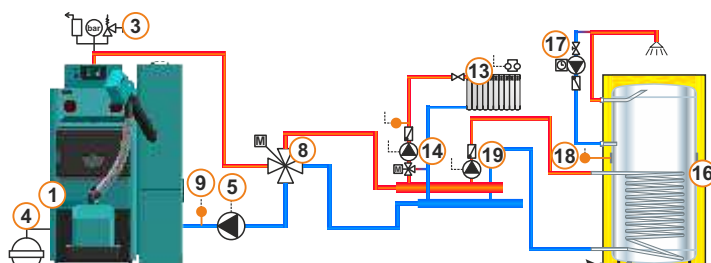
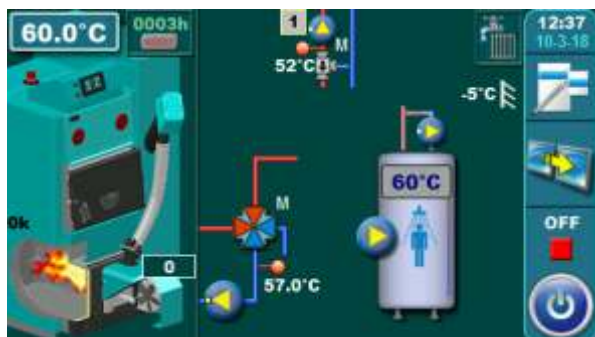

**Temperatures:** Tboiler: 80°C (70-90°C)  
 dTboiler: 10°C (5-15°C)  
 Tdhw: 50°C (10-70°C)  
 dTdhw: 5°C (5-50°C)

Circuit 1:  
 Const. temp. day: 60°C (20-90°C)  
 Const. temp. night: 60°C (20-90°C)  
 Day room temp.: 20°C (5-30°C)  
 Night room temp.: 20°C (5-30°C)

13.82. CONFIGURATION H-7-0

EKO-CKB P

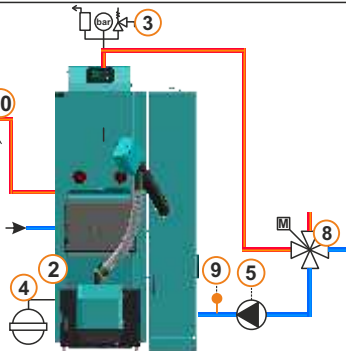
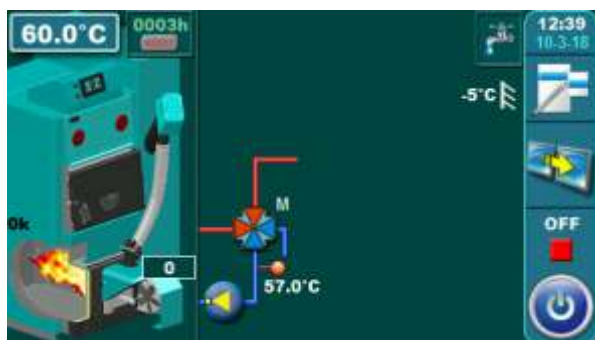

Temperatures:

- a) Boiler temperature maintenance switched off (authorized service technician has switched off boiler boiler temperature maintenance under INSTALLATION), the boiler operates only according to the heating or DHW request.  
**Note:** in this configuration, switching off the boiler temperature maintenance only makes sense if one or more CM2Ks are installed.  
 Tboiler: -> Heating+DHW: 80°C (70-80°C)      Tdhw: - Heating+DHW: Tdhw=Tboiler=80°C  
 - Mode: - DHW: 70°C (70-80°C)                      - Mode: - DHW: Tdhw=Tboiler=70°C  
 dTboiler: - Heating+DHW: 10°C (5-15°C)              dTdhw: - Heating+DHW: 15°C (10-40°C)  
 - Mode: DHW: 10°C (5-10°C)                              - Mode: DHW: 15°C (10-40°C)
- b) Boiler temperature maintenance is not switched off, the boiler maintains the set boiler temperature.  
 Tboiler:-> Heating+DHW: 80°C (70-90°C)              Tdhw:- Heating+DHW: Tdhw=Tboiler=80°C  
 - Mode: - DHW: 10°C (5-10°C)                              - Mode: - DHW: 15 (10-40°C)  
 dTboiler: - Heating+DHW: 10°C (5-15°C)              dTdhw: - Heating+DHW: 15°C (10-40°C)  
 - Mode: DHW: 10°C (5-10°C)                              - Mode: DHW: 15°C (10-40°C)

13.82.1. CONFIGURATION H-7-0

\*EKO-CKB P

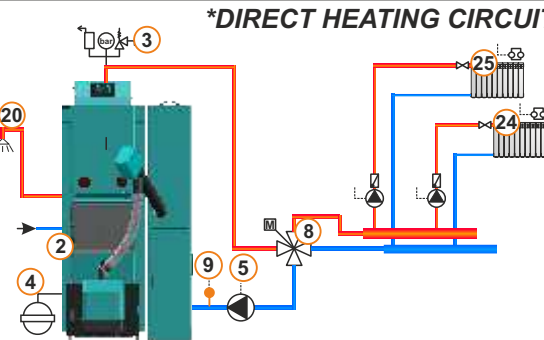
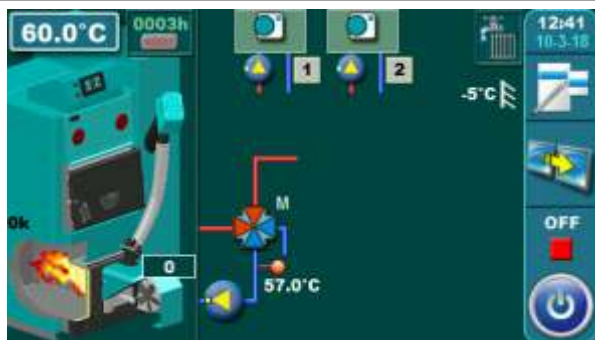

\*DIRECT HEATING CIRCUITS WITH PUMPS

- Temperatures: Tboiler: -> Heating+DHW: 80°C (70-80°C)      Tdhw: - Heating+DHW: Tdhw=Tboiler=80°C  
 - Mode: -> DHW: 70°C (70-80°C)                              - Mode: - DHW: Tdhw=Tboiler=70°C  
 dTboiler: - Heating+DHW: 10°C (5-15°C)                      dTdhw: - Heating+DHW: 15°C (10-40°C)  
 - Mode: - DHW: 10°C (5-10°C)                              - Mode: - DHW: 15°C (10-40°C)

13.82.2. CONFIGURATION H-7-0

\*EKO-CKB P

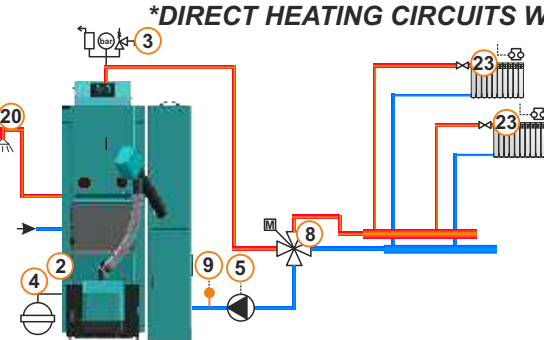
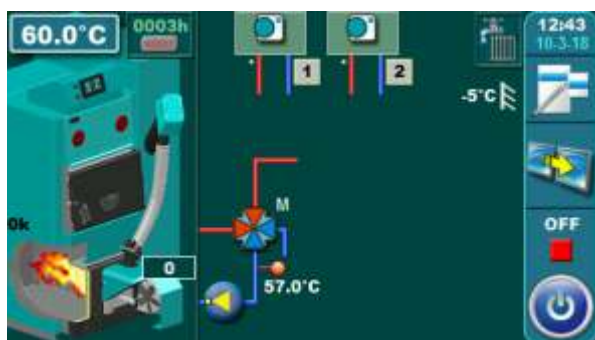

\*DIRECT HEATING CIRCUITS WITHOUT PUMPS

- Temperatures: Tboiler: -> Heating+DHW: 80°C (70-80°C)      Tdhw: - Heating+DHW: Tdhw=Tboiler=80°C  
 - Mode: -> DHW: 70°C (70-80°C)                              - Mode: - DHW: Tdhw=Tboiler=70°C  
 dTboiler: - Heating+DHW: 10°C (5-15°C)                      dTdhw: - Heating+DHW: 15°C (10-40°C)  
 - Mode: - DHW: 10°C (5-10°C)                              - Mode: - DHW: 15°C (10-40°C)

## 13.83. CONFIGURATION H-7-1

**EKO-CKB P**

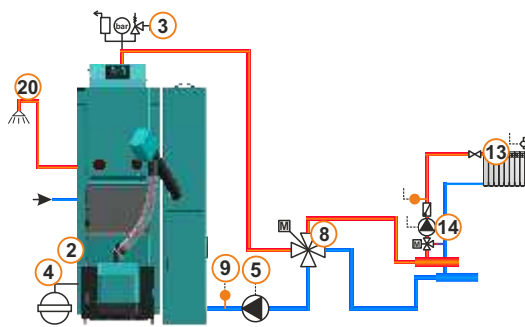
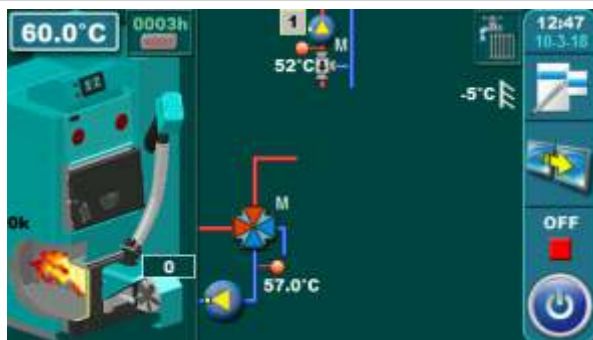

**Temperatures:**

a) Boiler temp. maintenance switched off (authorized service technician has switched off boiler boiler temp. maintenance under INSTALLATION), the boiler operates only according to the heating or DHW request.

Tboiler: -> Heating+DHW: 80°C (70-80°C)      Tdhw: - Heating+DHW: Tdhw=Tboiler=80°C  
 - Mode: - DHW: 70°C (70-80°C)                      - Mode: - DHW: Tdhw=Tboiler=70°C  
 dTboiler: - Heating+DHW: 10°C (5-15°C)          dTdhw: - Heating+DHW: 15°C (10-40°C)  
 - Mode: DHW: 10°C (5-10°C)                          - Mode: DHW: 15°C (10-40°C)

a) Circuit 1:  
 Const. temp. day: 60°C (20-80°C)  
 Const. temp. night: 60°C (20-80°C)  
 Day room temp.: 20°C (5-30°C)  
 Night room temp.: 20°C (5-30°C)

b) Boiler temperature maintenance is not switched off, the boiler maintains the set boiler temperature.

Tboiler:-> Heating+DHW: 80°C (70-90°C)      Tdhw:- Heating+DHW: Tdhw=Tboiler=80°C  
 - Mode: - DHW: 10°C (5-10°C)                      - Mode: - DHW: 15°C (10-40°C)  
 dTboiler: - Heating+DHW: 10°C (5-15°C)          dTdhw: - Heating+DHW: 15°C (10-40°C)  
 - Mode: DHW: 10°C (5-10°C)                          - Mode: DHW: 15°C (10-40°C)

b) Circuit 1:  
 Const. temp. day: 60°C (20-90°C)  
 Const. temp. night: 60°C (20-90°C)  
 Day room temp.: 20°C (5-30°C)  
 Night room temp.: 20°C (5-30°C)

## 13.84. CONFIGURATION H-8-0

**EKO-CKB P**

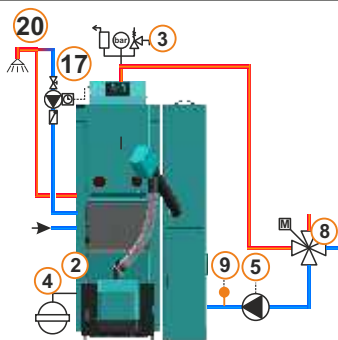
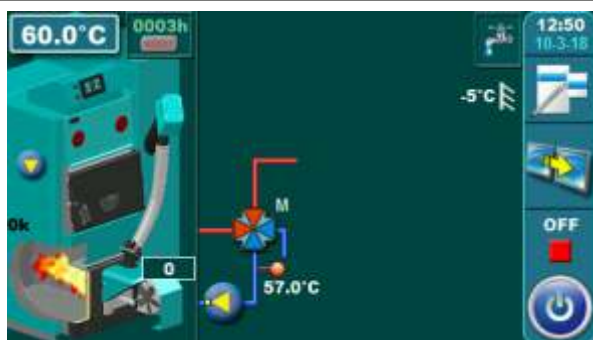

**Temperatures:**

a) Boiler temperature maintenance switched off (authorized service technician has switched off boiler boiler temperature maintenance under INSTALLATION), the boiler operates only according to the heating or DHW request.

**Note:** in this configuration, switching off the boiler temperature maintenance only makes sense if one or more CM2Ks are installed.

Tboiler: -> Heating+DHW: 80°C (70-80°C)      Tdhw: - Heating+DHW: Tdhw=Tboiler=80°C  
 - Mode: - DHW: 70°C (70-80°C)                      - Mode: - DHW: Tdhw=Tboiler=70°C  
 dTboiler: - Heating+DHW: 10°C (5-15°C)          dTdhw: - Heating+DHW: 15°C (10-40°C)  
 - Mode: DHW: 10°C (5-10°C)                          - Mode: DHW: 15°C (10-40°C)

b) Boiler temperature maintenance is not switched off, the boiler maintains the set boiler temperature.

Tboiler:-> Heating+DHW: 80°C (70-90°C)      Tdhw:- Heating+DHW: Tdhw=Tboiler=80°C  
 - Mode: - DHW: 10°C (5-10°C)                      - Mode: - DHW: 15°C (10-40°C)  
 dTboiler: - Heating+DHW: 10°C (5-15°C)          dTdhw: - Heating+DHW: 15°C (10-40°C)  
 - Mode: DHW: 10°C (5-10°C)                          - Mode: DHW: 15°C (10-40°C)

### 13.84.1 CONFIGURATION H-8-0

**\*EKO-CKB P**

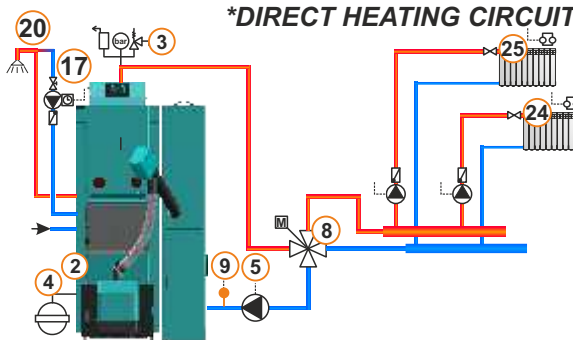
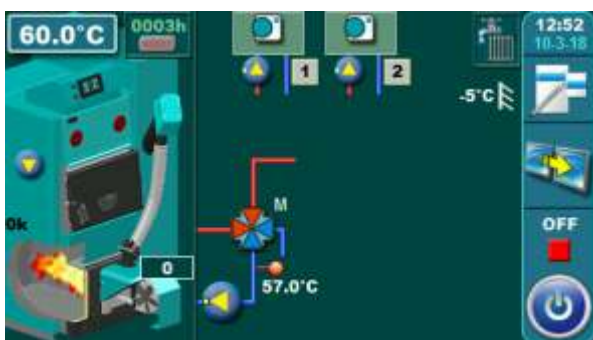

**Temperatures:** Tboiler: -> Heating+DHW: 80°C (70-80°C)  
 - Mode: -> DHW: 70°C (70-80°C)  
 dTboiler: - Heating+DHW: 10°C (5-15°C)  
 - Mode: - DHW: 10°C (5-10°C)

Tdhw: - Heating+DHW: Tdhw=Tboiler=80°C  
 - Mode: - DHW: Tdhw=Tboiler=70°C  
 dTdhw: - Heating+DHW: 15°C (10-40°C)  
 - Mode: - DHW: 15°C (10-40°C)

13.84.2. CONFIGURATION H-8-0

\*EKO-CKB P

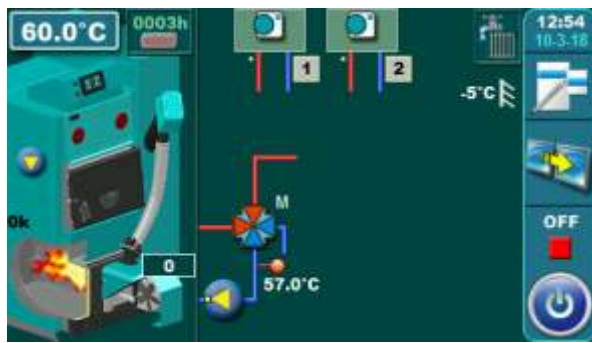

\*DIRECT HEATING CIRCUITS WITHOUT PUMPS

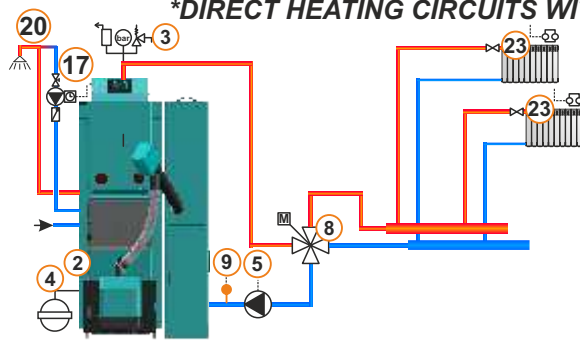

**Temperatures:** Tboiler: -> Heating+DHW: 80°C (70-80°C)  
 - Mode: -> DHW: 70°C (70-80°C)  
 dTboiler: - Heating+DHW: 10°C (5-15°C)  
 - Mode: - DHW: 10°C (5-10°C)

Tdhw: - Heating+DHW: Tdhw=Tboiler=80°C  
 - Mode: - DHW: Tdhw=Tboiler=70°C  
 dTdhw: - Heating+DHW: 15°C (10-40°C)  
 - Mode: - DHW: 15°C (10-40°C)

13.85. CONFIGURATION H-8-1

EKO-CKB P

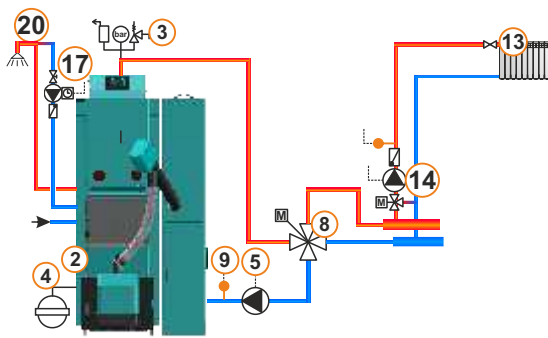

**Temperatures:**

a) Boiler temp. maintenance switched off (authorized service technician has switched off boiler boiler temp. maintenance under INSTALLATION), the boiler operates only according to the heating or DHW request.  
 Tboiler: -> Heating+DHW: 80°C (70-80°C)  
 - Mode: - DHW: 70°C (70-80°C)  
 dTboiler: - Heating+DHW: 10°C (5-15°C)  
 - Mode: DHW: 10°C (5-10°C)  
 b) Boiler temperature maintenance is not switched off, the boiler maintains the set boiler temperature.  
 Tboiler:-> Heating+DHW: 80°C (70-90°C)  
 - Mode: - DHW: 10°C (5-10°C)  
 dTboiler: - Heating+DHW: 10°C (5-15°C)  
 - Mode: DHW: 10°C (5-10°C)

a) Circuit 1:  
 Const. temp. day: 60°C (20-80°C)  
 Const. temp. night: 60°C (20-80°C)  
 Day room temp.: 20°C (5-30°C)  
 Night room temp.: 20°C (5-30°C)  
 b) Circuit 1:  
 Const. temp. day: 60°C (20-90°C)  
 Const. temp. night: 60°C (20-90°C)  
 Day room temp.: 20°C (5-30°C)  
 Night room temp.: 20°C (5-30°C)

13.86. CONFIGURATION I-0-0

EKO-CK P

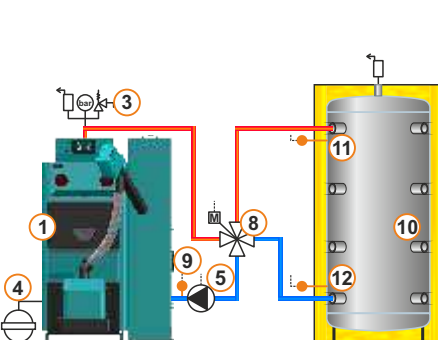
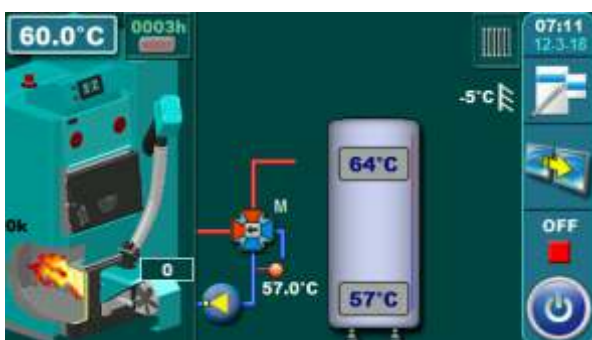

**Temperatures:** Tboiler: 80°C (80-90°C)  
 dTboiler: 10°C (5-15°C)  
 Tbuf: 80°C (70-80°C)  
 dTbuf: 10°C (5-30°C)  
 dTbuf-off: 5°C (3-50°C)

13.87. CONFIGURATION I-0-1

EKO-CK P

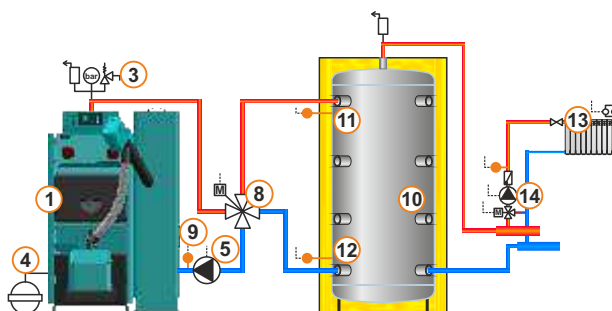
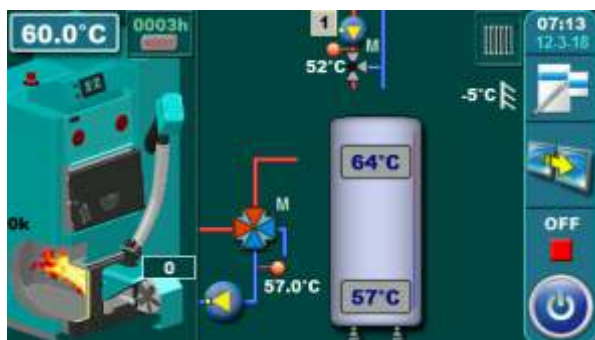

**Temperatures:** Tboiler: 80°C (80-90°C)  
dTboiler: 10°C (5-15°C)  
Tbuf: 80°C (70-80°C)  
dTbuf: 10°C (5-30°C)  
dTbuf-off: 5°C (3-50°C)

Tbuf min.: 20°C (5-85°C)

**Circuit 1:**  
Const. temp. day: 60°C (20-90°C)  
Const. temp. night: 60°C (20-90°C)  
Day room temp.: 20°C (5-30°C)  
Night room temp.: 20°C (5-30°C)

13.88. CONFIGURATION I-1-0

EKO-CK P

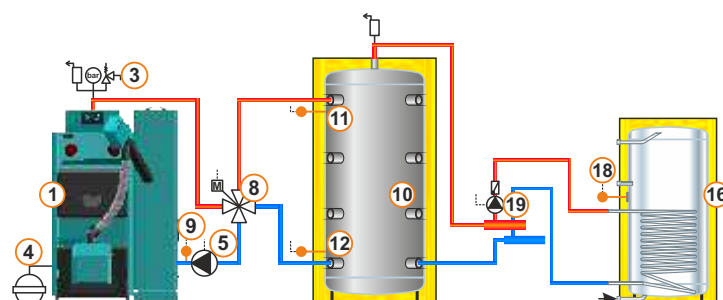
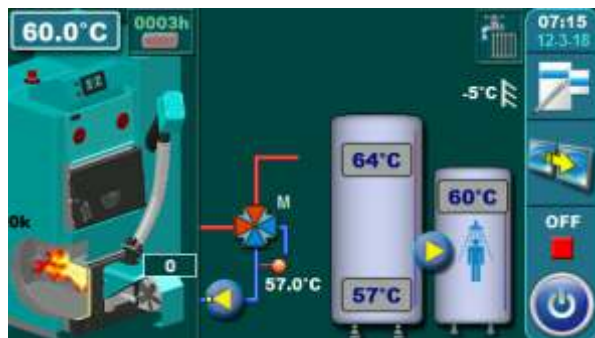

**Temperatures:** Tboiler: 80°C (80-90°C)  
dTboiler: 10°C (5-15°C)  
Tbuf: 80°C (70-80°C)  
dTbuf: 10°C (5-30°C)  
dTbuf-off: 5°C (3-50°C)

Tdhw: 50°C (10-70°C)  
dTdhw: 5°C (5-50°C)

13.89. CONFIGURATION I-1-1

EKO-CK P

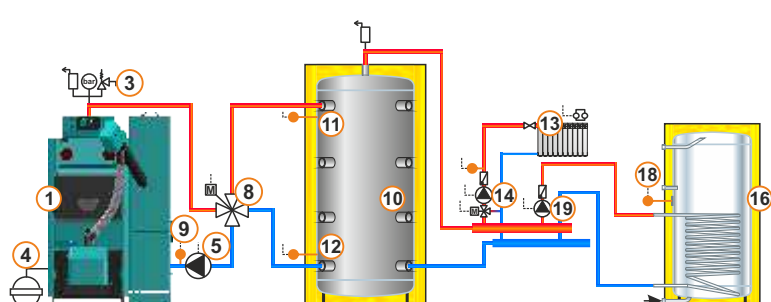
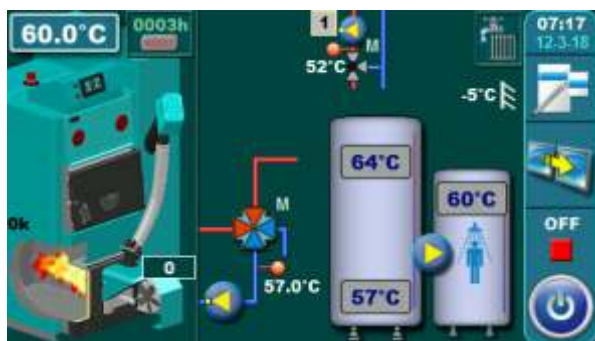

**Temperatures:** Tboiler: 80°C (80-90°C)  
dTboiler: 10°C (5-15°C)  
Tbuf: 80°C (70-80°C)  
dTbuf: 10°C (5-30°C)  
dTbuf-off: 5°C (3-50°C)

Tdhw: 50°C (10-70°C)  
dTdhw: 5°C (5-50°C)  
Tbuf min.: 20°C (5-85°C)

**Circuit 1:**  
Const. temp. day: 60°C (20-90°C)  
Const. temp. night: 60°C (20-90°C)  
Day room temp.: 20°C (5-30°C)  
Night room temp.: 20°C (5-30°C)

13.90. CONFIGURATION I-2-0

EKO-CK P

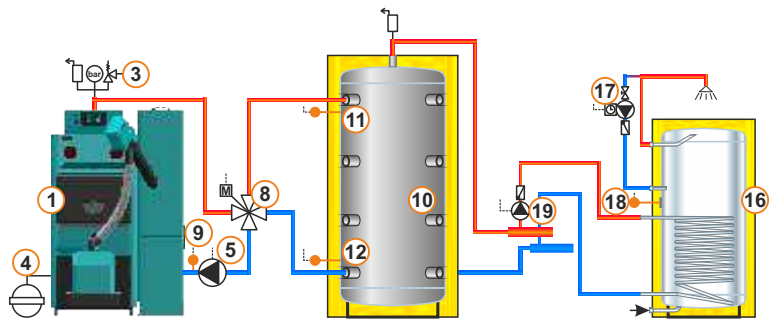
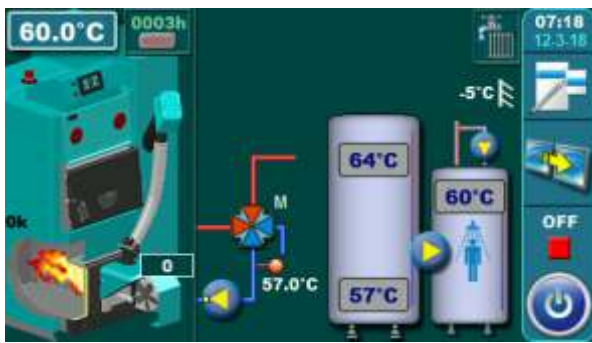

**Temperatures:** Tboiler: 80°C (80-90°C)  
 dTboiler: 10°C (5-15°C)  
 Tbuf: 80°C (70-80°C)  
 dTbuf: 10°C (5-30°C)  
 dTbuf-off: 5°C (3-50°C)

Tdhw: 50°C (10-70°C)  
 dTdhw: 5°C (5-50°C)

13.91. CONFIGURATION I-2-1

EKO-CK P

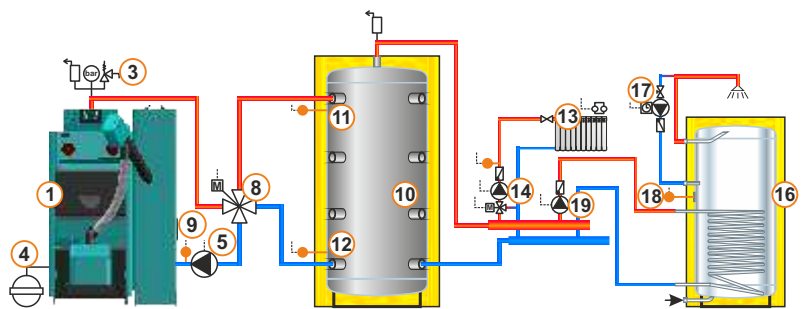
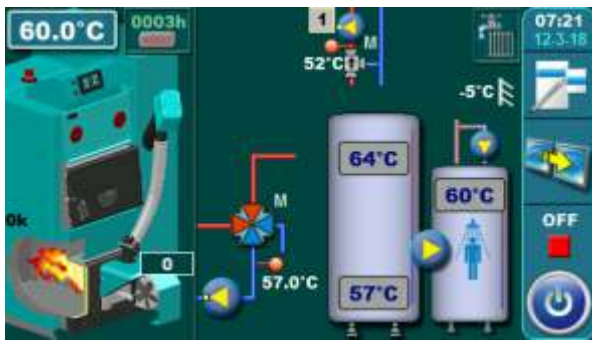

**Temperatures:** Tboiler: 80°C (80-90°C)  
 dTboiler: 10°C (5-15°C)  
 Tbuf: 80°C (70-80°C)  
 dTbuf: 10°C (5-30°C)  
 dTbuf-off: 5°C (3-50°C)

Tdhw: 50°C (10-70°C)  
 dTdhw: 5°C (5-50°C)  
 Tbuf min.: 20°C (5-85°C)

Circuit 1:  
 Const. temp. day: 60°C (20-90°C)  
 Const. temp. night: 60°C (20-90°C)  
 Day room temp.: 20°C (5-30°C)  
 Night room temp.: 20°C (5-30°C)

13.92. CONFIGURATION I-7-0

EKO-CKB P

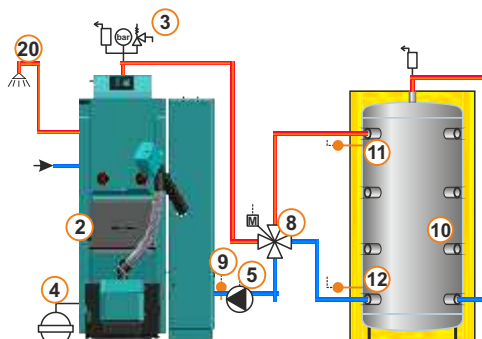
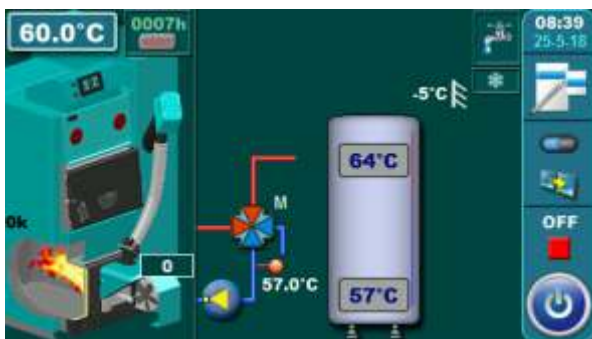

**Temperatures:**

Tboiler:  
 - Mode: -> Heating+DHW: 80°C (80-90°C)  
 -> DHW: 70°C (75-80°C)  
 dTboiler:  
 - Mode: - Heating+DHW: 10°C (5-15°C)  
 - DHW: 10°C (5-10°C)

Tdhw:  
 - Mode: - Heating+DHW: Tdhw=Tboiler=80°C  
 - DHW: Tdhw=Tboiler=70°C  
 dTdhw:  
 - Mode: - Heating+DHW: 15°C (10-40°C)  
 - DHW: 15°C (10-40°C)

Tbuf: 80°C (70-80°C)  
 dTbuf: 10°C (5-30°C)  
 dTbuf-off: 5°C (3-50°C)

13.93. CONFIGURATION I-7-1

EKO-CKB P

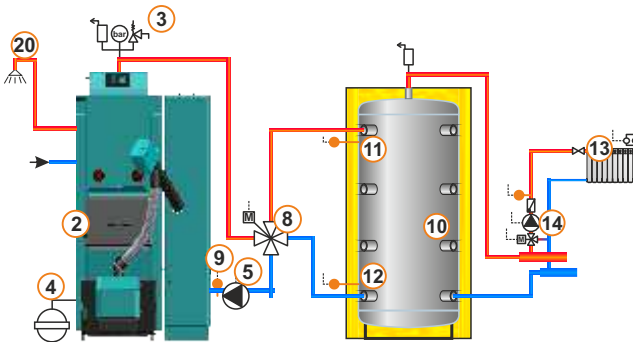
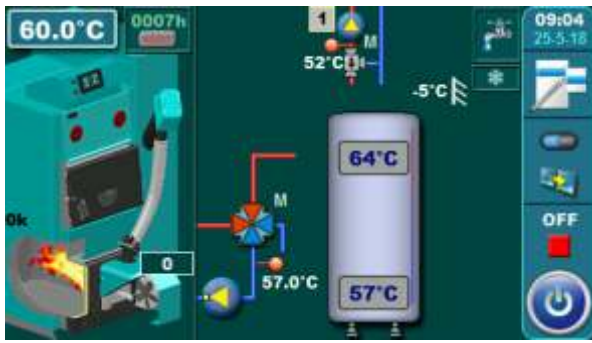

**Temperatures:**

Tboiler:  
 - Mode: -> Heating+DHW: 80°C (80-90°C)  
 -> DHW: 70°C (75-80°C)  
 dTboiler:  
 - Mode: - Heating+DHW: 10°C (5-15°C)  
 - DHW: 10°C (5-10°C)

Tdhw:  
 - Mode: - Heating+DHW: Tdhw=Tboiler=80°C  
 - DHW: Tdhw=Tboiler=70°C  
 dTdhw:  
 - Mode: - Heating+DHW: 15°C (10-40°C)  
 - DHW: 15 (10-40°C)

Tbuf: 80°C (70-80°C)  
 dTbuf: 10°C (5-30°C)  
 dTbuf-off: 5°C (3-50°C)  
 Tbuf min.: 20°C (5-85°C)

Circuit 1:  
 Const. temp. day: 60°C (20-90°C)  
 Const. temp. night: 60°C (20-90°C)  
 Day room temp.: 20°C (5-30°C)  
 Night room temp.: 20°C (5-30°C)

13.94. CONFIGURATION I-8-0

EKO-CKB P

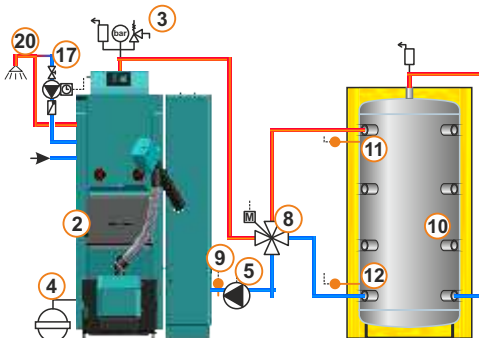
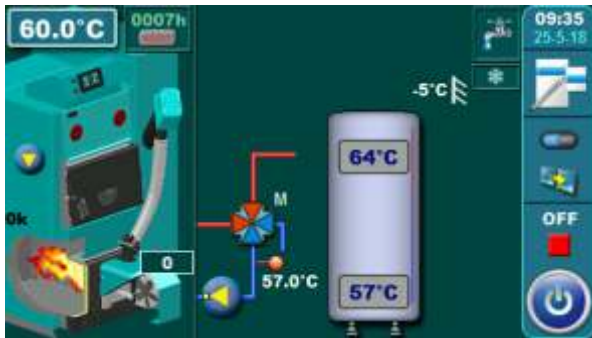

**Temperatures:**

Tboiler:  
 - Mode: -> Heating+DHW: 80°C (80-90°C)  
 -> DHW: 70°C (75-80°C)  
 dTboiler:  
 - Mode: - Heating+DHW: 10°C (5-15°C)  
 - DHW: 10°C (5-10°C)

Tdhw:  
 - Mode: - Heating+DHW: Tdhw=Tboiler=80°C  
 - DHW: Tdhw=Tboiler=70°C  
 dTdhw:  
 - Mode: - Heating+DHW: 15°C (10-40°C)  
 - DHW: 15°C (10-40°C)

Tbuf: 80°C (70-80°C)  
 dTbuf: 10°C (5-30°C)  
 dTbuf-off: 5°C (3-50°C)

13.95. CONFIGURATION I-8-1

EKO-CKB P

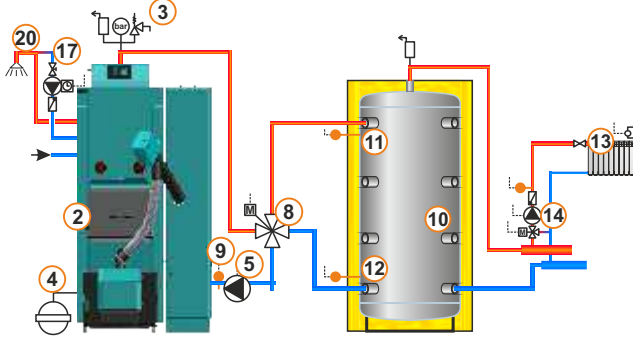
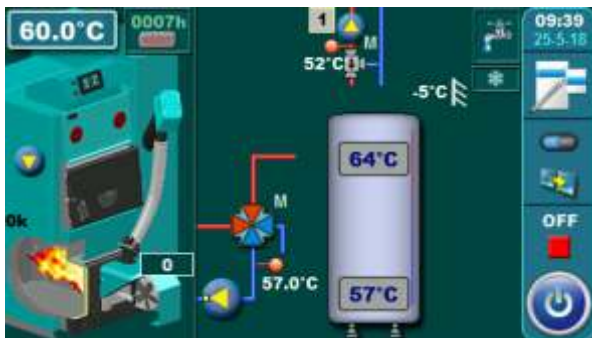

**Temperatures:**

Tboiler:  
 - Mode: -> Heating+DHW: 80°C (80-90°C)  
 -> DHW: 70°C (75-80°C)  
 dTboiler:  
 - Mode: - Heating+DHW: 10°C (5-15°C)  
 - DHW: 10°C (5-10°C)

Tdhw:  
 - Mode: - Heating+DHW: Tdhw=Tboiler=80°C  
 - DHW: Tdhw=Tboiler=70°C  
 dTdhw:  
 - Mode: - Heating+DHW: 15°C (10-40°C)  
 - DHW: 15°C (10-40°C)

Tbuf: 80°C (70-80°C)  
 dTbuf: 10°C (5-30°C)  
 dTbuf-off: 5°C (3-50°C)  
 Tbuf min.: 20°C (5-85°C)

Circuit 1:  
 Const. temp. day: 60°C (20-90°C)  
 Const. temp. night: 60°C (20-90°C)  
 Day room temp.: 20°C (5-30°C)  
 Night room temp.: 20°C (5-30°C)

13.96. CONFIGURATION J-0-0

EKO-CK P

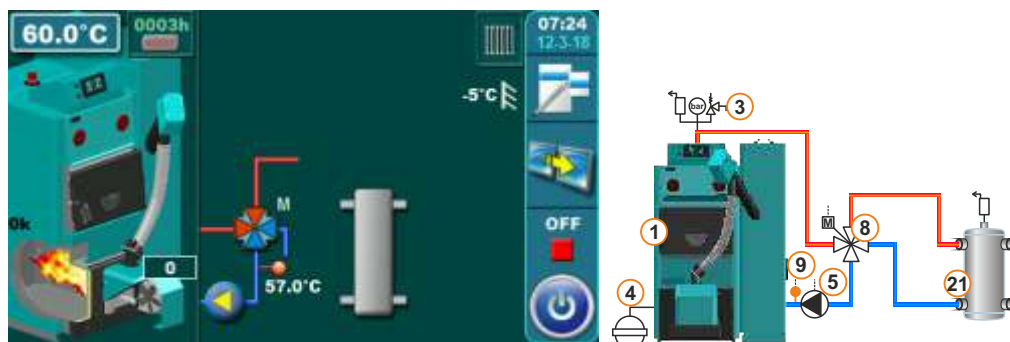

**Temperatures:** Tboiler: 80°C (70-90°C)  
dTboiler: 10°C (5-15°C)

13.97. CONFIGURATION J-0-1

EKO-CK P



**Temperatures:** Tboiler: 80°C (70-90°C)  
dTboiler: 10°C (5-15°C)

Circuit 1:  
Const. temp. day: 60°C (20-90°C)  
Const. temp. night: 60°C (20-90°C)  
Day room temp.: 20°C (5-30°C)  
Night room temp.: 20°C (5-30°C)

13.98. CONFIGURATION J-1-0

EKO-CK P

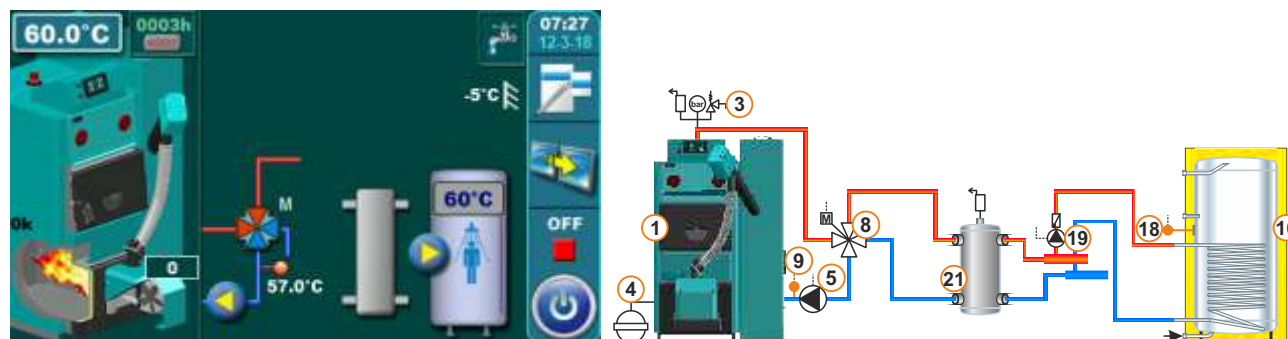

**Temperatures:** Tboiler: 80°C (70-90°C)  
dTboiler: 10°C (5-15°C)  
Tdhw: 50°C (10-70°C)  
dTdhw: 5°C (5-50°C)

13.99. CONFIGURATION J-1-1

EKO-CK P

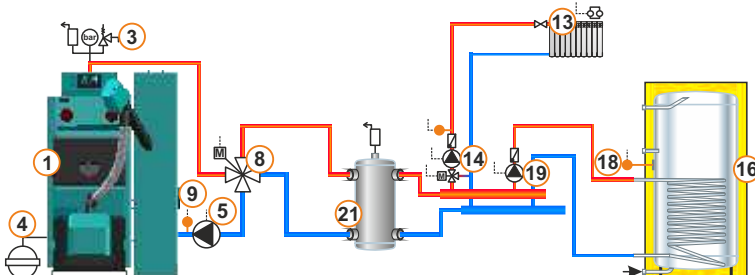
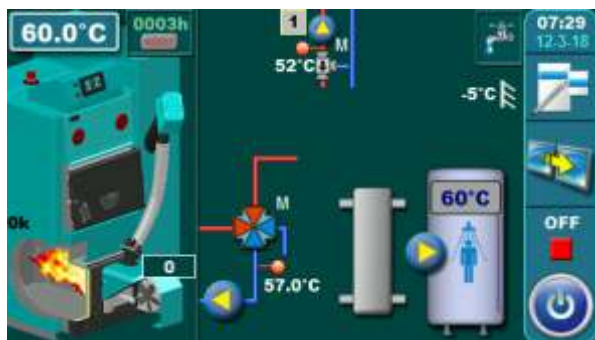

**Temperatures:** Tboiler: 80°C (70-90°C)  
 dTboiler: 10°C (5-15°C)  
 Tdhw: 50°C (10-70°C)  
 dTdhw: 5°C (5-50°C)

**Circuit 1:**  
 Const. temp. day: 60°C (20-90°C)  
 Const. temp. night: 60°C (20-90°C)  
 Day room temp.: 20°C (5-30°C)  
 Night room temp.: 20°C (5-30°C)

13.100. CONFIGURATION J-2-0

EKO-CK P

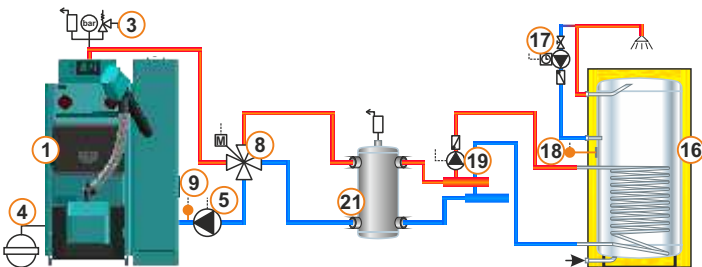
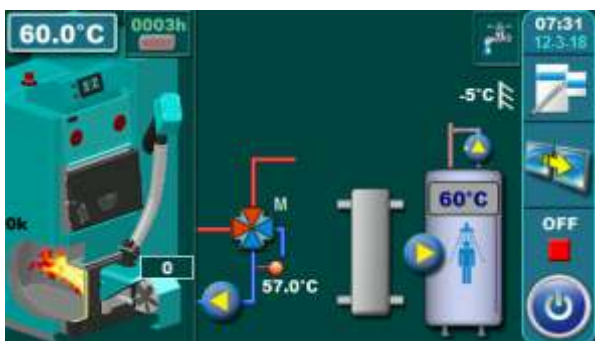

**Temperatures:** Tboiler: 80°C (70-90°C)  
 dTboiler: 10°C (5-15°C)  
 Tdhw: 50°C (10-70°C)  
 Tdhw: 5°C (5-50°C)

13.101. CONFIGURATION J-2-1

EKO-CK P

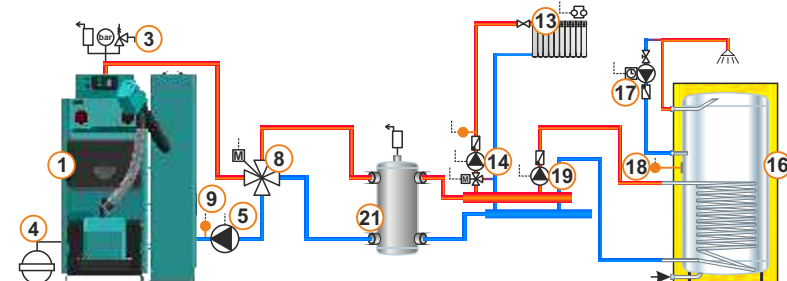
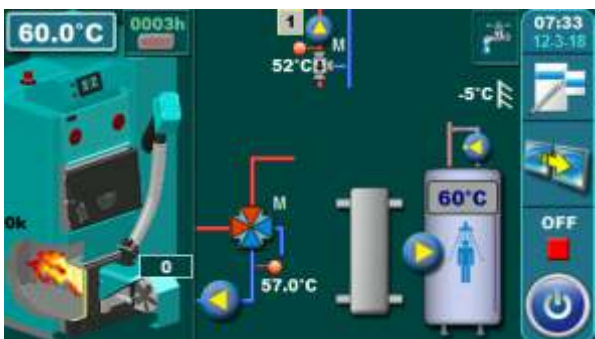

**Temperatures:** Tboiler: 80°C (70-90°C)  
 dTboiler: 10°C (5-15°C)  
 Tdhw: 50°C (10-70°C)  
 dTdhw: 5°C (5-50°C)

**Circuit 1:**  
 Const. temp. day: 60°C (20-90°C)  
 Const. temp. night: 60°C (20-90°C)  
 Day room temp.: 20°C (5-30°C)  
 Night room temp.: 20°C (5-30°C)

13.102. CONFIGURATION J-7-0

EKO-CKB P

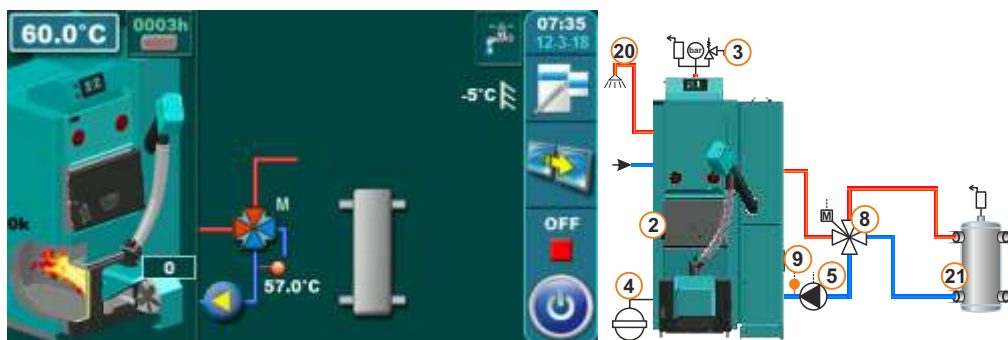

**Temperatures:** Tboiler: -> Heating+DHW: 80°C (70-90°C) - Mode: -> DHW: 70°C (70-80°C)  
 dTboiler: - Heating+DHW: 10°C (5-15°C) - Mode: - DHW: 10°C (5-10°C)  
 Tdhw: - Heating+DHW: Tdhw=Tboiler=80°C - Mode: - DHW: Tdhw=Tboiler=70°C  
 dTdhw: - Heating+DHW: 15°C (10-40°C) - Mode: - DHW: 15°C (10-40°C)

13.103. CONFIGURATION J-7-1

EKO-CKB P

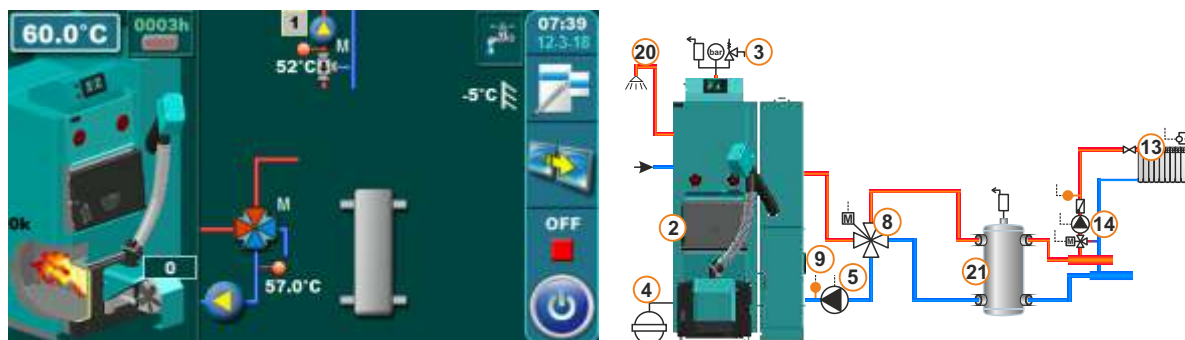

**Temperatures:** Tboiler: - Mode: -> Heating+DHW: 80°C (70-90°C) -> DHW: 70°C (70-80°C)  
 dTboiler: - Mode: - Heating+DHW: 10°C (5-15°C) - DHW: 10°C (5-10°C)  
 Tdhw: - Mode: - Heating+DHW: Tdhw=Tboiler=80°C - DHW: Tdhw=Tboiler=70°C  
 dTdhw: - Mode: - Heating+DHW: 15°C (10-40°C) - DHW: 15°C (10-40°C)  
 Circuit 1:  
 Const. temp. day: 60°C (20-90°C)  
 Const. temp. night: 60°C (20-90°C)  
 Day room temp.: 20°C (5-30°C)  
 Night room temp.: 20°C (5-30°C)

13.104. CONFIGURATION J-8-0

EKO-CKB P

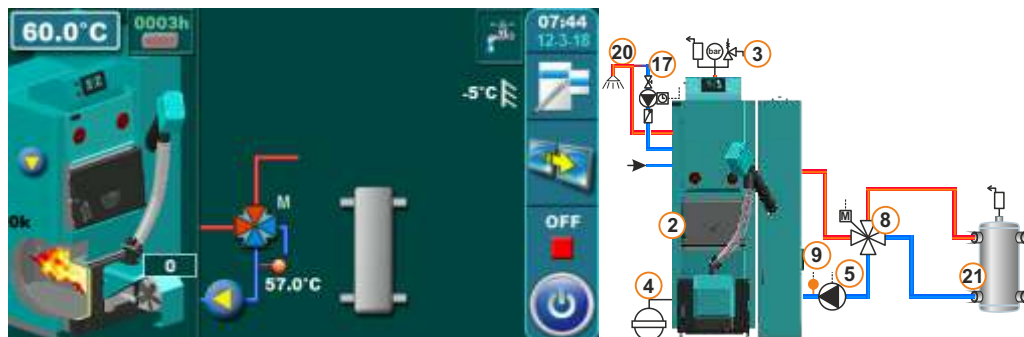

**Temperatures:** Tboiler: -> Heating+DHW: 80°C (70-90°C) - Mode: -> DHW: 70°C (70-80°C)  
 dTboiler: - Heating+DHW: 10°C (5-15°C) - Mode: - DHW: 10°C (5-10°C)  
 Tdhw: - Heating+DHW: Tdhw=Tboiler=80°C - Mode: - DHW: Tdhw=Tboiler=70°C  
 dTdhw: - Heating+DHW: 15°C (10-40°C) - Mode: - DHW: 15°C (10-40°C)

13.105. CONFIGURATION J-8-1

EKO-CKB P

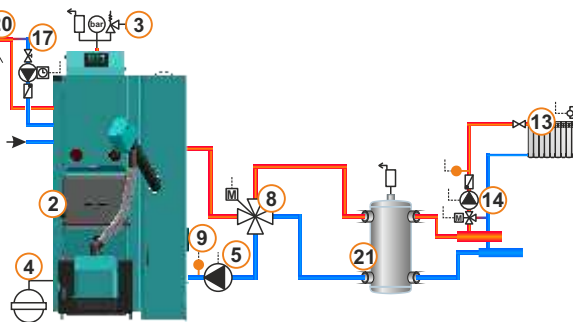
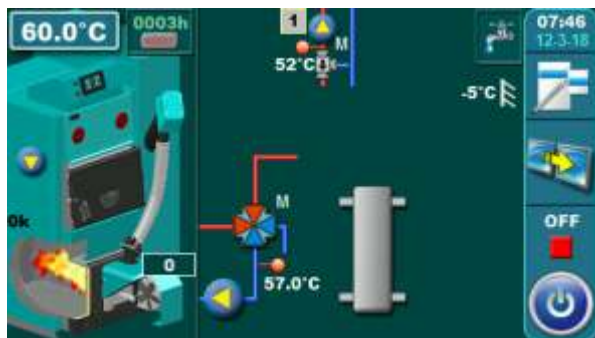

**Temperatures:** Tboiler:  
 - Mode: -> Heating+DHW: 80°C (70-90°C)  
 -> DHW: 70°C (70-80°C)  
 dTboiler:  
 - Mode: - Heating+DHW: 10°C (5-15°C)  
 - DHW: 10°C (5-10°C)

Tdhw:  
 - Mode: - Heating+DHW: Tdhw=Tboiler=80°C  
 - DHW: Tdhw=Tboiler=70°C  
 dTdhw:  
 - Mode: - Heating+DHW: 15°C (10-40°C)  
 - DHW: 15°C (10-40°C)

Circuit 1:  
 Const. temp. day: 60°C (20-90°C)  
 Const. temp. night: 60°C (20-90°C)  
 Day room temp.: 20°C (5-30°C)  
 Night room temp.: 20°C (5-30°C)

13.106. CONFIGURATION K-0-0

EKO-CK P

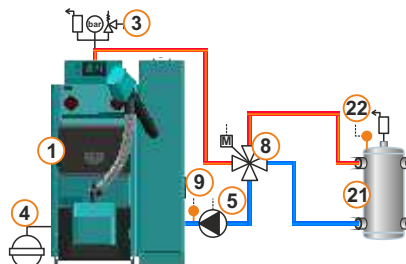
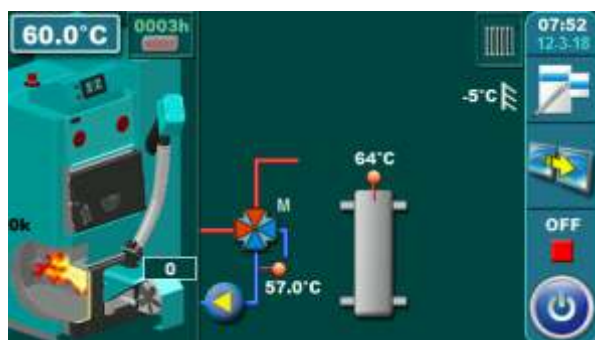

**Temperatures:** Tboiler: 80°C (75-90°C)  
 dTboiler: 10°C (5-15°C)  
 Tcro: 75°C (70-80°C)

13.107. CONFIGURATION K-0-1

EKO-CK P

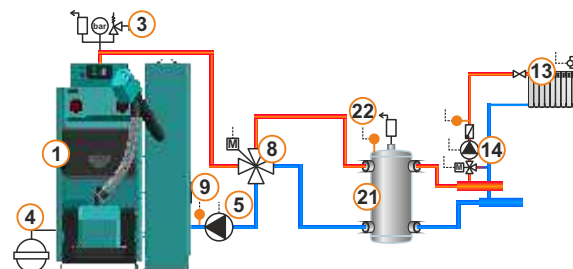
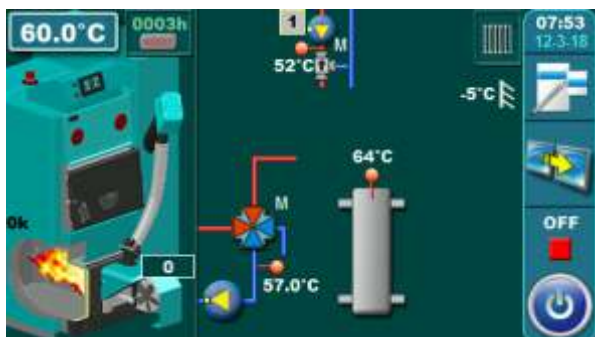

**Temperatures:** Tboiler: 80°C (75-90°C)  
 dTboiler: 10°C (5-15°C)  
 Tcro: 75°C (70-80°C)

Circuit 1:  
 Const. temp. day: 60°C (20-90°C)  
 Const. temp. night: 60°C (20-90°C)  
 Day room temp.: 20°C (5-30°C)  
 Night room temp.: 20°C (5-30°C)

13.108. CONFIGURATION K-1-0

EKO-CK P

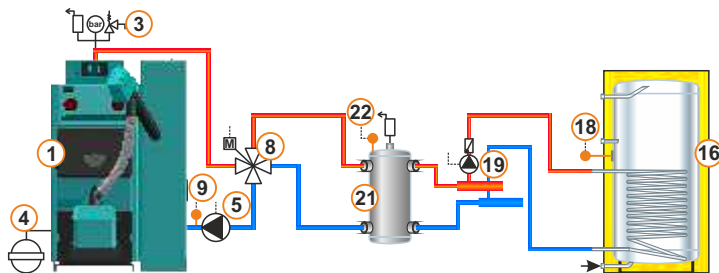
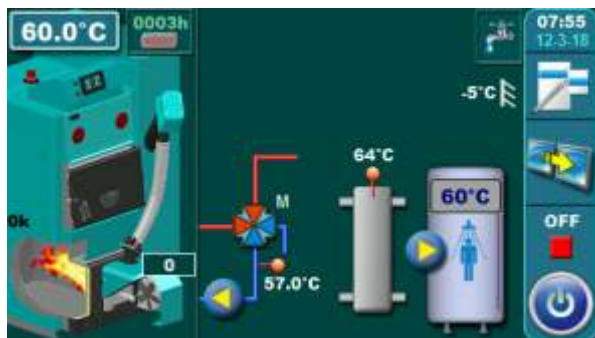

**Temperatures:** Tboiler: 80°C (75-90°C)  
 dTboiler: 10°C (5-15°C)  
 Tcro: 75°C (70-80°C)  
 Tdhw: 50°C (10-73°C)  
 dTdhw: 5°C (5-50°C)

13.109. CONFIGURATION K-1-1

EKO-CK P

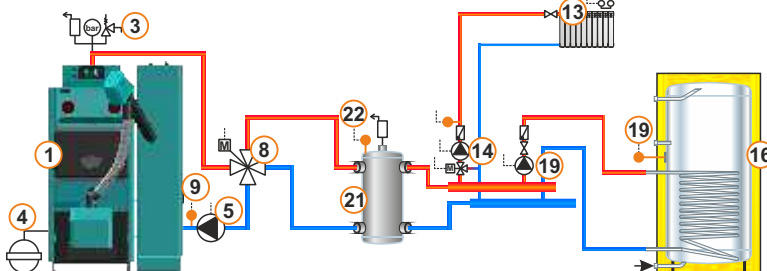
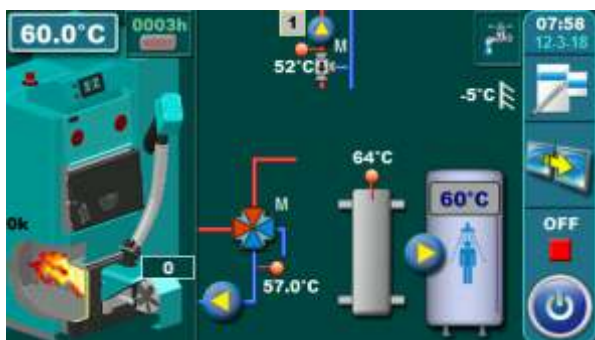

**Temperatures:** Tboiler: 80°C (75-90°C)  
 dTboiler: 10°C (5-15°C)  
 Tcro: 75°C (70-80°C)  
 Tdhw: 50°C (10-73°C)  
 dTdhw: 5°C (5-50°C)

Circuit 1:  
 Const. temp. day: 60°C (20-90°C)  
 Const. temp. night: 60°C (20-90°C)  
 Day room temp.: 20°C (5-30°C)  
 Night room temp.: 20°C (5-30°C)

13.110. CONFIGURATION K-2-0

EKO-CK P

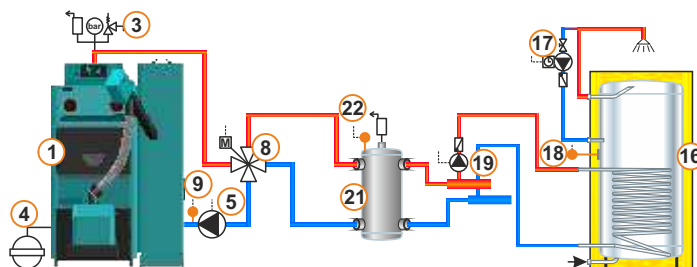
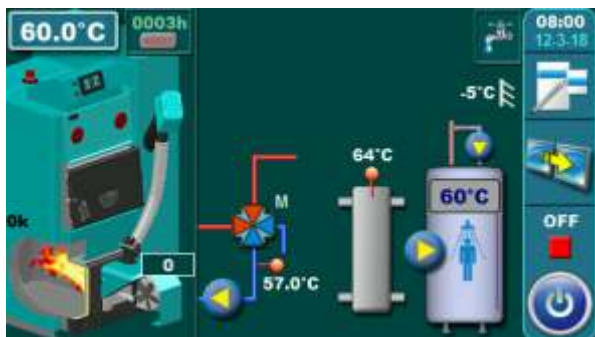

**Temperatures:** Tboiler: 80°C (75-90°C)  
 dTboiler: 10°C (5-15°C)  
 Tcro: 75°C (70-80°C)  
 Tdhw: 50°C (10-73°C)  
 dTdhw: 5°C (5-50°C)

13.111. CONFIGURATION K-2-1

EKO-CK P

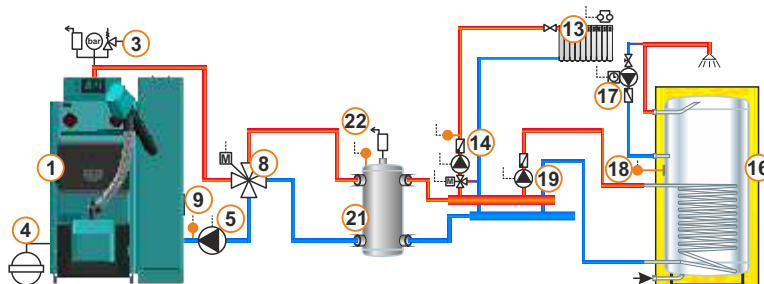
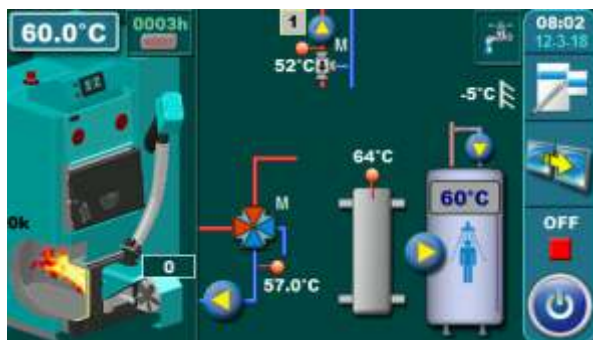

**Temperatures:** Tboiler: 80°C (75-90°C)  
 dTboiler: 10°C (5-15°C)  
 Tcro: 75°C (70-80°C)  
 Tdhw: 50°C (10-73°C)  
 dTdhw: 5°C (5-50°C)

Circuit 1:  
 Const. temp. day: 60°C (20-90°C)  
 Const. temp. night: 60°C (20-90°C)  
 Day room temp.: 20°C (5-30°C)  
 Night room temp.: 20°C (5-30°C)

13.112. CONFIGURATION K-7-0

EKO-CKB P

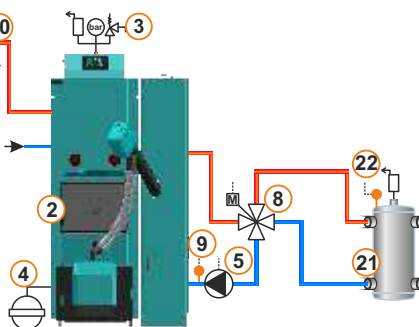
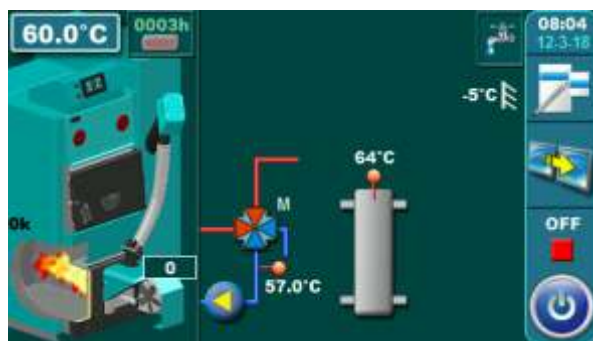

**Temperatures:** Tboiler: -> Heating+DHW: 80°C (75-90°C)  
 - Mode: -> DHW: 70°C (75-80°C)  
 dTboiler: - Heating+DHW: 10°C (5-15°C)  
 - Mode: - DHW: 10°C (5-10°C)

Tdhw: - Heating+DHW: Tdhw=Tboiler=80°C  
 - Mode: - DHW: Tdhw=Tboiler=70°C  
 dTdhw: - Heating+DHW: 15°C (10-40°C)  
 - Mode: - DHW: 15°C (10-40°C)  
 Tcro: 75°C (70-80°C)

13.113. CONFIGURATION K-7-1

EKO-CKB P

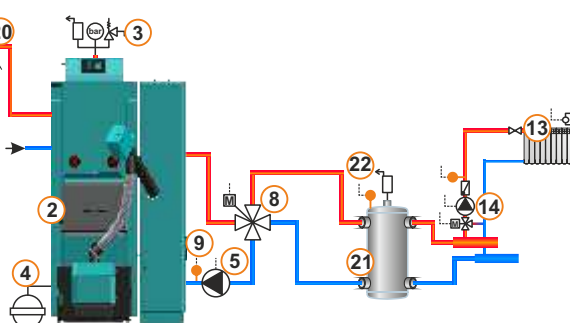
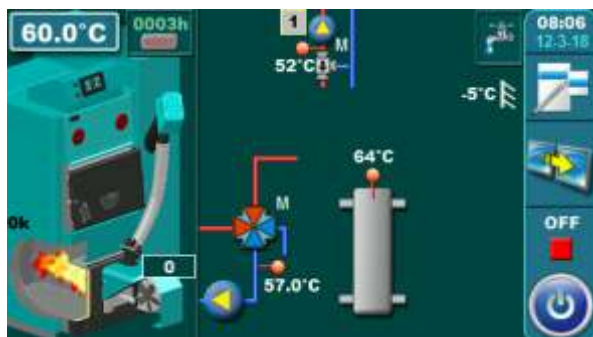

**Temperatures:** Tboiler:  
 - Mode: -> Heating+DHW: 80°C (75-90°C)  
 -> DHW: 70°C (75-80°C)  
 dTboiler:  
 - Mode: - Heating+DHW: 10°C (5-15°C)  
 - DHW: 10°C (5-10°C)

Tdhw:  
 - Mode: - Heating+DHW: Tdhw=Tboiler=80°C  
 - DHW: Tdhw=Tboiler=70°C  
 dTdhw:  
 - Mode: - Heating+DHW: 15°C (10-40°C)  
 - DHW: 15°C (10-40°C)  
 Tcro: 75°C (70-80°C)

Circuit 1:  
 Const. temp. day: 60°C (20-90°C)  
 Const. temp. night: 60°C (20-90°C)  
 Day room temp.: 20°C (5-30°C)  
 Night roomtemp.: 20°C (5-30°C)

13.114. CONFIGURATION K-8-0

EKO-CKB P

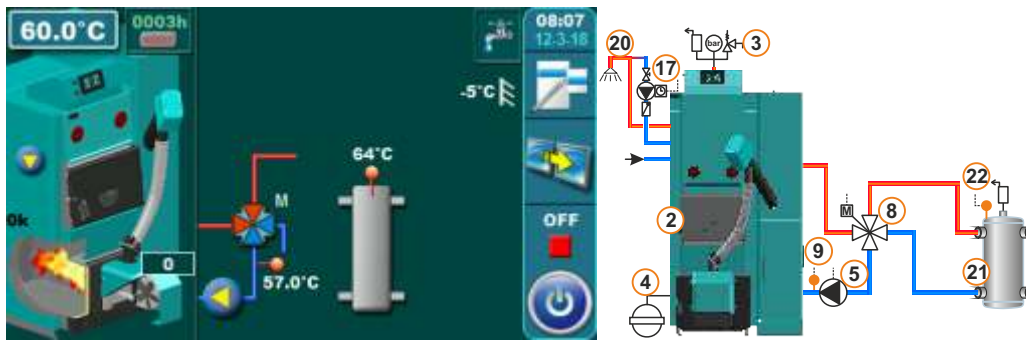

**Temperatures:** Tboiler: -> Heating+DHW: 80°C (75-90°C) Tdhw: - Heating+DHW: Tdhw=Tboiler=80°C  
 - Mode: -> DHW: 70°C (75-80°C) - Mode: - DHW: Tdhw=Tboiler=70°C  
 dTboiler: - Heating+DHW: 10°C (5-15°C) dTdhw: - Heating+DHW: 15°C (10-40°C)  
 - Mode: - DHW: 10°C (5-10°C) - Mode: - DHW: 15°C (10-40°C)  
 Tcro: 75°C (70-80°C)

13.115. CONFIGURATION K-8-1

EKO-CKB P

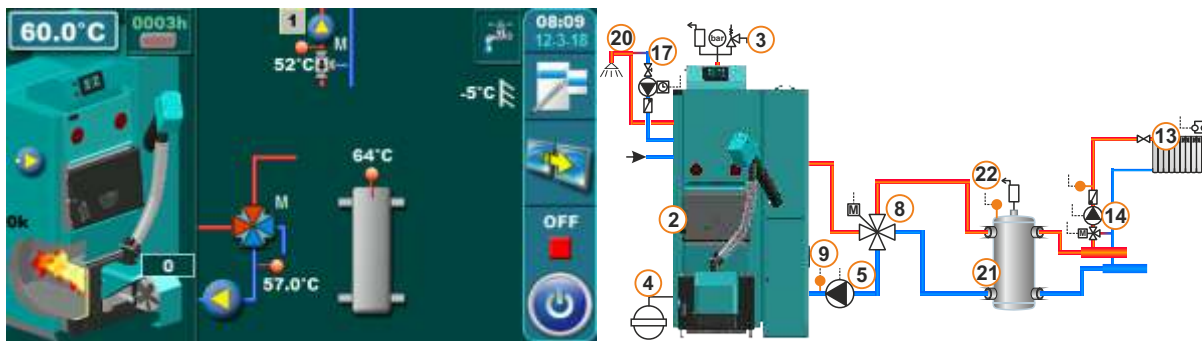

**Temperatures:** Tboiler: -> Heating+DHW: 80°C (75-90°C) Tdhw: - Heating+DHW: Tdhw=Tboiler=80°C  
 - Mode: -> DHW: 70°C (75-80°C) - Mode: - DHW: Tdhw=Tboiler=70°C  
 dTboiler: - Heating+DHW: 10°C (5-15°C) dTdhw: - Heating+DHW: 15°C (10-40°C)  
 - Mode: - DHW: 10°C (5-10°C) - Mode: - DHW: 15°C (10-40°C)  
 Tcro: 75°C (70-80°C)

Circuit 1:  
 Const. temp. day: 60°C (20-90°C)  
 Const. temp. night: 60°C (20-90°C)  
 Day room temp.: 20°C (5-30°C)  
 Night room temp.: 20°C (5-30°C)

### **Legend:**

- 1** - Boiler **EKO-CK P + Cm Pelet set**
- 2** - Boiler **EKO-CKB P + Cm Pelet set**
- 3** - Safety-vent group (safety valve 2,5 bar)
- 4** - Closed expansion vessel
- 5** - Pump **P1**
- 6** - Backflow protection:
  - 3-way mixing valve (min. 60 C)
- 7** - Backflow protection:
  - 3-way mixing valve with actuator (**MVAL2**)
- 8** - Backflow protection:
  - 4-way mixing valve with actuator (**MVAL2**)
- 9** - Backflow sensor (**CIRCUIT2**)
- 10** - Accumulation tank
- 11** - Upper sensor of the accumulation tank (**BUFFER1**)
- 12** - Lower sensor of the accumulation tank (**BUFFER2**)
- 13** - Mixing heating circuit
- 14** - 1. circuit flow sensor (**CIRCUIT1**) + pump (**P4**) + actuator (**MVAL1**)
- 15** - 2. circuit flow sensor (**CIRCUIT2**) + pump (**P5**) + actuator (**MVAL2**)
- 16** - DHW tank
- 17** - DHW recirculation (**P3**)
- 18** - DHW tank sensor (**DHW**)
- 19** - DHW tank pump (**P2**)
- 20** - DHW tank in the boiler
- 21** - Hydraulic crossover (**CRO**)
- 22** - Hydraulic crossover temperature sensor (**HS**)
- 23** - Direct heating circuit (radiator) with room thermostat or room corrector
- 24** - Direct heating circuit (radiator) with room thermostat or room corrector + pump (**P4**)
- 25** - Direct heating circuit (radiator) with room thermostat or room corrector + pump (**P5**)

## 14.0 ERRORS AND WARNINGS

### 14.1 LIST AND TROUBLESHOOTING OF ERRORS

ERROR	NAME	DESCRIPTION
E0	COMMUNICATION ERROR WITH MOTHERBOARD	<p><b>Possible cause:</b> No communication between the PC board and other parts of the boiler.</p> <p><b>Boiler status:</b> Currently goes to OFF mode</p> <p><b>Troubleshooting:</b> Call an authorized serviceman who will check everything</p>
E1	PRESSURE	<p><b>Possible cause:</b> Excessive furnaces resistance</p> <p><b>Boiler status:</b> Currently goes to OFF mode.</p> <p><b>Troubleshooting:</b> Check the filling of the boiler furnace and flue gas passes, chimney filling, and correct operation of the pressure switch.</p>
E2	IGNITION ERROR	<p><b>Possible cause:</b> In safety time (12 min.) the flame did not appear.</p> <p><b>Boiler status:</b> Currently goes to OFF mode.</p> <p><b>Troubleshooting:</b> Check that there is a pellet in the pellet tank/transporter, if there are any foreign bodies in the transporter, that the flexible pellet delivery tube has a drop to the burner so that the pellets can fall smoothly into the burner, whether the burner grate is well placed in the burner (is not installed ON the el. heater), whether the pellets are not too humid, whether the pellets of the appropriate dimensions (for these burner settings are 6 mm in diameter), whether the burner blows hot air (whether the electric heater has blown), whether the initial pellet supply is sufficient.</p>
E2_1	IGNITIONERRORAFTER POWERFAIL	<p><b>Possible cause:</b> In safety time (12 min.) the flame did not appear, and before that, the current disappeared in one of the burner stages except "OFF", "A0" I S7-3.</p> <p><b>Boiler status:</b> Currently goes to OFF mode.</p> <p><b>Troubleshooting:</b> Check that there is a pellet in the pellet tank, whether there is a pellet in the transporter, if the flexible pellet tube has a drop in the burner so that pellets can fall smoothly into the burner, that the flexible tube is not damaged (blown or burnt) whether the burner grate is overcrowded with the remains of burnt pellets, whether the burner grid is well positioned in the burner (is not installed ON the el. heater), whether the pellets are not too humid, whether the pellets are of adequate dimensions (for these burner diameters 6 mm in diameter) the burner grate is crammed with the remains of burnt pellets, whether the burner blows hot air (whether the el. heater has blown), whether the photocell is clean. Clean the grate and burner.</p>
E3	PELLET SUPPLY TUBE TEMPERATURE TOO HIGH	<p><b>Possible cause:</b> The temperature of the pellet flexible filling tube on the burner is higher than 80° C.</p> <p><b>Boiler status:</b> Currently goes to OFF mode.</p>

E3	PELLET SUPPLY TUBE TEMPERATURE TOO HIGH	<p><b>Troubleshooting:</b> Possible fulfilling of the burner furnace and flexible tube due to incorrectly adjusted combustion air, incorrectly tuned delivery parameters, inadequate dimensions or pellet quality, possible hole on the flexible tube or fall of the flexible tube from the delivery tube, possible fan stoppage, possible impassable flue gas passages in boiler and chimney.</p>
E4	INCORRECT BOILER SENSOR	<p><b>Possible cause:</b> Break in the cables between the sensor and control, control contacts, cold connection or defective boiler sensor.  <b>Boiler status:</b> departure to shutdown mode.S7 (S7-1).  <b>Troubleshooting:</b> Call an authorized serviceman to check the sensor location in the tank, check for sensor/cable damage, check connections at the connectors, check the ohmic resist. of the sensor.</p>
E5	INCORRECT DHW SENSOR	<p><b>Possible cause:</b> Break in the cables between the sensor and control, control contacts, cold connection or defective boiler sensor.  <b>Boiler status:</b> departure to shutdown mode S7 (S7-1). If the user turns off the DHW fault stops and the boiler can start.  <b>Troubleshooting:</b> Call an authorized serviceman to check the sensor location in the tank, check for sensor/cable damage, check connections at the connectors, check the ohmic resist. of the sensor.</p>
E6	FLAME LOSS WHILE WORKING	<p><b>Possible cause:</b> The photocell does not see the flame in the burner furnace.  <b>Boiler status:</b> Currently goes to OFF mode.  <b>Troubleshooting:</b> Check that the fault is caused by the loss of pellets (in the tank/transporter), the congestion of the transporter motor, the spiral of the transporter, the foreign body in the transporter, the improper supply, the supply of too humid pellets, the burning of the burner grate to the remains of pellet combustion or the scorching of the photocell.</p>
E6_1	FLAME LOSS AFTER POWER FAIL	<p><b>Possible cause:</b> The photocell does not see the flame during the burner operation in the burner furnace, before which the current has disappear. in one of the burner stages except "OFF", "A0" and "S7-3".  <b>Boiler status:</b> departure to shutdown mode S7 (S7-1).  <b>Troubleshooting:</b> Check that the fault is caused by the loss of pellets (in the tank / transporter), faulty feeding ,feeding of the too humid pellets, the burning of the burner grate to the remains of pellet combustion or the scorching of the photocell. Clean grate and burner.</p>
E7	WRONG DATE AND TIME	<p><b>Possible cause:</b> Low or fully charged battery. Clock reset at 00:00 and date on 1.1.2000. after switching off or unplugging (or not configured), and at least one switching time (boiler/DHW/recirculation) is switched on. If no switching time is on, this error will not occur, but Warning W2. This burner failure can not be detected by itself, it can only occur if a switch-on time is triggered in the work while we have a W2 warning, in which case the burner goes into the S7 (S7-1) shutdown phase. If any currents, during the burner operation (all stages except "OFF", "A0" and S7-3) are disconnected, then the current is returned and the E7 is acknowledged, the boiler will perform the necessary actions after power failure and will not start due to mistakes. If the currents are gone when the burner is in the "OFF", "A0" and "S7-3" stages, and then the currents return to the E7, the boiler will not start due to an error.  <b>Boiler status:</b> The boiler can operate, if all the switching times are off, otherwise it can not operate. The boiler states under different circumstances are described above „Possible cause“.  <b>Troubleshooting:</b> It is necessary to replace the battery (CR1220) on the control panel PC board.</p>

<p><b>E8</b></p>	<p>FAN MALFUNCTION</p>	<p><b>Possible cause:</b> The RPM sensor does not see the fan rotation.  <b>Boiler status:</b> Currently goes to OFF mode.  <b>Troubleshooting:</b> Check for the possible rotation of the RPM sensor, due to the arrangement of the fan bearings (to see if the sprocket is free to rotate), due to the input of the external body into the fan coil, due to the release of the thermal protection of the fan (after cooling the 30°C fan can be started again) due to too low network voltage.</p>
<p><b>E9</b></p>	<p>BACKFILLING SUPPLY TUBE WITH PELLETS</p>	<p><b>Possible cause:</b> fulfilling the pellet filling tube with pellets  <b>Boiler status:</b> Currently goes to OFF mode.  <b>Troubleshooting:</b> Check the fullness of the burner grate, burner furnace, boiler furnace, and chimney, whether the burner grate is well positioned in the burner (is not installed ON the el. heater) - valid for CPPL 14-50), whether pellets are not too humid, inadequate dimensions or quality pellets (for these burner diameters 6 mm), possible holes on the flexible tube pipe, too much pellet delivery / low rpm, incorrectly loaded filling parameters, incorrect combustion air.</p>
<p><b>E9_1</b></p>	<p>BACKFILLING SUPPLY TUBE WITH PELLETS</p>	<p><b>Possible cause:</b> Filling the flexible tube with pellets - variant_1 - when it is in operation reduced pellet supply over a period of time in which it failed to return to the normal filling regime with fulfilling (factory only active on CPPL 90)  <b>Boiler status:</b> Currently goes to OFF mode.  <b>Troubleshooting:</b> Check the fullness of the burner gate, burner furnace, boiler furnace, and chimney, whether the burner grate is well positioned in the burner (is not installed ON the el. heater) - valid for CPPL 14-50), whether pellets are not too humid, inadequate dimensions or quality pellets (for these burner diameters 6 mm), possible holes on the flexible tube pipe, too much pellet delivery/low rpm, incorrectly loaded filling parameters, incorrect combustion air.</p>
<p><b>E9_2</b></p>	<p>BACKFILLING SUPPLY TUBE WITH PELLETS</p>	<p><b>Possible cause:</b> Filling the flexible tube with pellets - variant_2 - when it is in operation reduced pellet supply over a period of time in which it failed to return to the normal filling regime with fulfilling (factory only active on CPPL 90)  <b>Boiler status:</b> Currently goes to OFF mode  <b>Troubleshooting:</b> Check the fullness of the burner gate, burner furnace, boiler furnace, and chimney, whether the burner grate is well positioned in the burner (is not installed ON the el. heater) - valid for CPPL 14-50), whether pellets are not too humid, inadequate dimensions or quality pellets (for these burner diameters 6 mm), possible holes on the flexible tube pipe, too much pellet delivery/low rpm, incorrectly loaded filling parameters, incorrect combustion air.</p>

E10	INCORRECT BUFFER TANK SENSOR UP	<p><b>Possible cause:</b> Interruption in cables between sensors and control, control contacts, cold connection or defective sensor in the accu tank upper part.</p> <p><b>Boiler status:</b> Departure to the Shutdown phase S7 (S7-1).</p> <p><b>Troubleshooting:</b> Call an authorized service person to check the sensor location in the tank, check for sensor/cable damage, check connections at the connectors, check the ohmic resistance of the sensor.</p>
E11	INCORRECT BUFFER TANK SENSOR DOWN	<p><b>Possible cause:</b> Interruption in cables between sensors and control, control contacts, cold connection or defective sensor in the accu. tank lower part.</p> <p><b>Boiler status:</b> Departure to the Shutdown phase S7 (S7-1).</p> <p><b>Troubleshooting:</b> Call an authorized service person to check the sensor location in the tank, check for sensor/cable damage, check connections at the connectors, check the ohmic resistance of the sensor.</p>
E12	INCORRECT CROSSOVER TEMPERATURE SENSOR UP	<p><b>Possible cause:</b> Interruption in cables between sensors and control, control contacts, cold connection or defective sensor</p> <p><b>Boiler status:</b> Departure to the Shutdown phase S7 (S7-1).</p> <p><b>Troubleshooting:</b> Call an authorized service person to check the location of the sensor, check for sensor / cable damage, check connections at the connectors, check the ohmic resistance of the sensor.</p>
E13	INCORRECT RETURN LINE SENSOR	<p><b>Possible cause:</b> Interruption in cables between sensors and control, control contacts, cold connection or defective sensor.</p> <p><b>Boiler status:</b> Departure to the S7 (S7-1) phase, if the pump P1 is in operation and there is a mixing valve (return protection) it goes to 50% openness.</p> <p><b>Troubleshooting:</b> Call an authorized service person to check the location of the sensor, check for sensor / cable damage, check connections at the connectors, check the ohmic resistance of the sensor.</p>
E14	INCORRECT OUTSIDE TEMPERATURE SENSOR	<p><b>Possible cause:</b> Interruption in the cables between the sensor and control (CM2K), control contacts, cold connection or defective sensor.</p> <p><b>Boiler status:</b> The boiler operate normally, but all heating circuits which are using external temperature sensor shutdown the pump and the freeze protection condition (if it is switched on) automatically assumes that the outside temperature meets the freeze protection condition (unless the authorized service person has switched off the external temperature requirement).</p> <p><b>Troubleshooting:</b> Call an authorized service person to check the location of the sensor, check for sensor / cable damage, check connections at the connectors, check the ohmic resistance of the sensor.</p>

## Errors

E15	SENSOR 1. CIRCUIT	<p><b>Possible cause:</b> Termination in cables between the 1st heating circuit and control sensor, control contact, cold connection or defective sensor.</p> <p><b>Boiler status:</b> The boiler operate normally, the 1st circuit stops to operate, shutdown the pump.</p> <p><b>Troubleshooting:</b> Call an authorized service person to check the location of the sensor, check for sensor / cable damage, check connections at the connectors, check the ohmic resistance of the sensor.</p>
E16	CORRECTOR 1. CIRCUIT	<p><b>Possible cause:</b> Termination in cables between the 1st heating circuit regulator and control, control contact, cold connection or defective corrector.</p> <p><b>Boiler status:</b> The boiler operate normally, the 1st heating circuit continues to perate as if the corrector is off.</p> <p><b>Troubleshooting:</b> Call a qualified service person to check the location of the corrector, check for damage/correctness of the correctors and cable, check the connectors on the connectors.</p>
E17	SENSOR 2. CIRCUIT	<p><b>Possible cause:</b> Termination in cables between the 2nd heating circuit and control sensor, control contacts, cold connection or defective sensor.</p> <p><b>Boiler status:</b> The boiler operate normally, 2 circuit stop to operate, switch off the pump.</p> <p><b>Troubleshooting:</b> Call an authorized service person to check the location of the sensor, check for sensor / cable damage, check connections at the connectors, check the ohmic resistance of the sensor.</p>
E18	CORRECTOR 2. CIRCUIT	<p><b>Possible cause:</b> Termination in the cables between the 2 heating circuit connector and control unit. Control unit contacts, cold connection or defective corrector.</p> <p><b>Boiler status:</b> The boiler operate normally, the 2nd heating circuit continues to operate as if the converter is off.</p> <p><b>Troubleshooting:</b> Call a qualified service person to check the location of the corrector, check for damage / correctness and cable , check the connection of the the connectors.</p>
E19	PHOTOCELL ERROR	<p><b>Possible cause:</b> Interruption in cables between the photocell and control, control contacts, cold or faulty photocell.</p> <p><b>Boiler status:</b> Departure in phase of shutdown S7 (S7-1).</p> <p><b>Troubleshooting:</b> Contact an authorized service person to check the damage / correctness of the photocell and the cable , check the connections on the connectors.</p>
E20	SAFETY THERMOSTAT OR DOOR MICROSWITCH	<p><b>Possible cause:</b> Too high boiler water temperature (above 101 °C) or open lower boiler door, poorly positioned microswitch at the bottom boiler door (not pressed enough when the door is closed), defective microswitch with lower boiler door.</p> <p><b>Boiler status:</b> The pellet transporter and the burner fan momentarily stop operating, ie the boiler is currently in the OFF phase. The fan and the transporter lose power and do not even run the manual test.</p> <p><b>Troubleshooting:</b> If the lower boiler doors are open they should be closed, if they are closed, check the position of the microswitch (if it is pressed sufficiently) and its correctness. If everything is checked with the microswitch and the fault is still active, check that it has released the safety thermostat. Wait for the water temp. in the boiler to be below 70 °C and perform the procedure from "SAFETY THERMOSTAT_Case of boiler operation".</p>

E21	INCORRECT RECIRCULATION SENSOR	<p><b>Possible cause:</b> Interruption in cables between sensors and control, control contacts, cold connection or defective sensor.</p> <p><b>Boiler status:</b> boiler operate normally.</p> <p><b>Troubleshooting:</b> Call a qualified service person to check the location of the sensor, check for sensor/cable damage, check connectors on the connectors, check the ohmic resistance of the sensor.</p>
E22	UNKNOWN BOILER POWER!	<p><b>Possible cause:</b> Problem with the “code key “ for the power reading:</p> <ul style="list-style-type: none"> <li>- the key is not placed, not recognized, has a malfunction, we have a cold junction or the key is defective.</li> </ul> <p><b>Boiler status:</b> Currently goes to OFF mode.</p> <p><b>Troubleshooting:</b> Call an authorized serviceman who will check the damage/accuracy of the “ key “ and the connections.</p>
E23	WRONG BOILER POWER!	<p><b>Possible cause:</b> A wrong “ key “ is placed for the power reading or a wrong screen (used on another boiler – with another power).</p> <p><b>Boiler status:</b> Currently goes to OFF mode</p> <p><b>Troubleshooting:</b> Call an authorized serviceman to check the accuracy of the key/screen.</p>
E24	FUEL LEVEL	<p><b>Possible cause:</b> Too low pellet level in the tank for a normal operation.</p> <p><b>Boiler status:</b> Entering the extinguishing phase S7(S7 – 1 ).</p> <p><b>Troubleshooting:</b> Fill the tank with pellets minimal above the pellet level sensor in the tank.</p>
E100_1	COMMUNICATION ERROR WITH CM2K (1+&2+)	<p><b>Possible cause:</b> Defective UTP cable or connections on the controller's PCB boards and CM2K.</p> <p><b>Boiler status:</b> The boiler operates normally.</p> <p><b>Troubleshooting :</b> Call an authorized serviceman who will check all.</p>
E100_2	COMMUNICATION ERROR WITH CM2K (3+&4+)	<p><b>Possible cause:</b> Defective UTP cable or connections on the CM2K controller's PCB boards.</p> <p><b>Boiler status:</b> The boiler operates normally.</p> <p><b>Troubleshooting:</b> Call an authorized serviceman who will check all.</p>
E100_3	COMMUNICATION ERROR WITH CM2K (5+&6+)	<p><b>Possible cause:</b> Defective UTP cable or connections on the CM2K controller's PCB boards.</p> <p><b>Boiler status:</b> The boiler operates normally.</p> <p><b>Troubleshooting:</b> Call an authorized serviceman who will check all.</p>
E100_4	COMMUNICATION ERROR WITH CM2K (7+&8+)	<p><b>Possible cause:</b> Defective UTP cable or connections on the CM2K controller's PCB boards.</p> <p><b>Boiler status:</b> The boiler operates normally.</p> <p><b>Troubleshooting:</b> Call an authorized serviceman who will check all.</p>
E100_5	COMMUNICATION ERROR WITH CMGSM	<p><b>Possible cause:</b> Defective UTP cable or connections on the controller's PCB boards and CMGSM.</p> <p><b>Boiler status:</b> The boiler operates normally.</p> <p><b>Troubleshooting :</b> Call an authorized serviceman who will check all.</p>

## Errors

E100_6	COMMUNICATION ERROR WITH CM WIFI MODULE	<p><b>Possible cause:</b> Defective UTP cable or connections on the controller's PCB boards and WiFi box.</p> <p><b>Boiler status:</b> The boiler operates normally.</p> <p><b>Troubleshooting:</b> Call an authorized serviceman who will check all.</p>
E100_7	COMMUNICATION ERROR WITH CMNET	<p><b>Possible cause:</b> Defective UTP cable or connections on the controller's PCB boards and CMNET.</p> <p><b>Boiler status:</b> The boiler operates normally as an individual boiler ( does not operate in a cascade ).</p> <p><b>Troubleshooting:</b> Call an authorized serviceman who will check all.</p>
E100_8	COMMUNICATION ERROR WITH CMVAC	<p><b>Possible cause:</b> Error communication with the vacuum suction, defective UTP cable or connections on the controller's PCB boards and CMVAC.</p> <p><b>Boiler status :</b> The boiler operates normally.</p> <p><b>Troubleshooting:</b> Call an authorized serviceman who will check all.</p>
E100_9	NOT ACTIVE	
E101	SENSOR CM2K 1+ CIRCUIT	<p><b>Possible cause:</b> Interruption in the cables between the 1<sup>st</sup> circuit sensor and CM2K, connections on the CM2K, cold junction or defective sensor.</p> <p><b>Boiler status:</b> The boiler operates normally, the 1<sup>st</sup> CM2K circuit stops to operate , stops ( turns off ) the pump.</p> <p><b>Troubleshooting:</b> Call an authorized serviceman who will check the sensor position , check the damage/accuracy of the sensor and cable , check the contacts on the connectors, check the sensor's ohm resistance.</p>
E102	CORRECTOR CM2K 1+ CIRCUIT	<p><b>Possible cause:</b> Interruption in the cables between the 1<sup>st</sup> circuit corrector and CM2K, connections on the CM2K , cold junction or defective corrector.</p> <p><b>Boiler status:</b> The boiler operates normally, the 1<sup>st</sup> CM2K circuit continues to operate as if the corrector is turned off.</p> <p><b>Troubleshooting:</b> Call an authorized serviceman who will check the corrector position , check the damage/accuracy of the corrector and cable, check the contacts on the connectors.</p>
E103	SENSOR CM2K 2+ CIRCUIT	<p><b>Possible cause:</b> Interruption in the cables between the 2<sup>nd</sup> circuit sensor and CM2K, connections on the CM2K, cold junction or defective sensor.</p> <p><b>Boiler status:</b> The boiler operates normally, the 2<sup>nd</sup> CM2K circuit stops to operate, stops (turns off) the pump.</p> <p><b>Troubleshooting:</b> Call an authorized serviceman who will check the sensor position, check the damage/accuracy of the sensor and cable, check the contacts on the connectors, check the sensor's ohm resistance.</p>
E104	CORRECTOR CM2K 2+ CIRCUIT	<p><b>Possible cause:</b> Interruption in the cables between the 2<sup>nd</sup> circuit corrector and CM2K, connections on the CM2K, cold junction or defective corrector.</p> <p><b>Boiler status:</b> The boiler operates normally, the 2<sup>nd</sup> CM2K circuit continues to operate as if the corrector is turned off.</p> <p><b>Troubleshooting:</b> Call an authorized serviceman who will check the corrector position, check the damage/accuracy of the corrector and cable, check the contacts on the connectors.</p>

<p><b>E105</b></p>	<p>SENSOR CM2K 3+ CIRCUIT</p>	<p><b>Possible cause:</b> Interruption in the cables between the 3<sup>rd</sup> circuit sensor and CM2K, connections on the CM2K, cold junction or defective sensor  <b>Boiler status:</b> The boiler operates normally, the 3<sup>rd</sup> CM2K circuit stops to operate, stops (turns off) the pump.  <b>Troubleshooting:</b> Call an authorized serviceman who will check the sensor position, check the damage/accuracy of the sensor and cable, check the contacts on the connectors, check the sensor's ohm resistance.</p>
<p><b>E106</b></p>	<p>CORRECTOR CM2K 3+ CIRCUIT</p>	<p><b>Possible cause:</b> Interruption in the cables between the 3<sup>rd</sup> circuit corrector and CM2K, connections on the CM2K, cold junction or defective corrector.  <b>Boiler status:</b> The boiler operates normally, the 3<sup>rd</sup> CM2K circuit continues to operate as if the corrector is turned off.  <b>Troubleshooting:</b> Call an authorized serviceman who will check the corrector position, check the damage/accuracy of the corrector and cable, check the contacts on the connectors.</p>
<p><b>E107</b></p>	<p>SENSOR CM2K 4+ CIRCUIT</p>	<p><b>Possible cause:</b> Interruption in the cables between the 4<sup>th</sup> circuit sensor and CM2K, connections on the CM2K, cold junction or defective sensor.  <b>Boiler status:</b> The boiler operates normally, the 4<sup>th</sup> CM2K circuit stops to operate, stops (turns off) the pump.  <b>Troubleshooting:</b> Call an authorized serviceman who will check the sensor position , check the damage/accuracy of the sensor and cable, check the contacts on the connectors, check the sensor's ohm resistance.</p>
<p><b>E108</b></p>	<p>CORRECTOR CM2K 4+ CIRCUIT</p>	<p><b>Possible cause:</b> Interruption in the cables between the 4<sup>th</sup> circuit corrector and CM2K, connections on the CM2K , cold junction or defective corrector  <b>Boiler status:</b> The boiler operates normally, the 4<sup>th</sup> CM2K circuit continues to operate as if the corrector is turned off.  <b>Troubleshooting:</b> Call an authorized serviceman who will check the corrector position, check the damage/accuracy of the corrector and cable, check the contacts on the connectors.</p>
<p><b>E109</b></p>	<p>SENSOR CM2K 5+ CIRCUIT</p>	<p><b>Possible cause:</b> Interruption in the cables between the 5<sup>th</sup> circuit sensor and CM2K, connections on the CM2K, cold junction or defective sensor  <b>Boiler status:</b> The boiler operates normally, the 5<sup>th</sup> CM2K circuit stops to operate, stops (turns off) the pump.  <b>Troubleshooting:</b> Call an authorized serviceman who will check the sensor position, check the damage/accuracy of the sensor and cable, check the contacts on the connectors, check the sensor's ohm resistance.</p>
<p><b>E110</b></p>	<p>CORRECTOR CM2K 5+ CIRCUIT</p>	<p><b>Possible cause:</b> Interruption in the cables between the 5<sup>th</sup> circuit corrector and CM2K, connections on the CM2K, cold junction or defective corrector  <b>Boiler status:</b> The boiler operates normally, the 5<sup>th</sup> CM2K circuit continues to operate as if the corrector is turned off.  <b>Troubleshooting:</b> Call an authorized serviceman who will check the corrector position, check the damage/accuracy of the corrector and cable, check the contacts on the connectors.</p>

<p>E111</p>	<p>SENSOR CM2K 6+ CIRCUIT</p>	<p><b>Possible cause:</b> Interruption in the cables between the 6<sup>th</sup> circuit sensor and CM2K, connections on the CM2K, cold junction or defective sensor.  <b>Boiler status:</b> The boiler operates normally, the 6<sup>th</sup> CM2K circuit stops to operate, stops (turns off) the pump.  <b>Troubleshooting:</b> Call an authorized serviceman who will check the sensor position, check the damage/accuracy of the sensor and cable, check the contacts on the connectors, check the sensor's ohm resistance.</p>
<p>E112</p>	<p>CORRECTOR CM2K 6+ CIRCUIT</p>	<p><b>Possible cause:</b> Interruption in the cables between the 6<sup>th</sup> circuit corrector and CM2K, connections on the CM2K, cold junction or defective corrector  <b>Boiler status:</b> The boiler operates normally, the 6<sup>th</sup> CM2K circuit continues to operate as if the corrector is turned off.  <b>Troubleshooting:</b> Call an authorized serviceman who will check the corrector position, check the damage/accuracy of the corrector and cable, check the contacts on the connectors.</p>
<p>E113</p>	<p>SENSOR CM2K 7+ CIRCUIT</p>	<p><b>Possible cause:</b> Interruption in the cables between the 7<sup>th</sup> circuit sensor and CM2K, connections on the CM2K, cold junction or defective sensor.  <b>Boiler status:</b> The boiler operates normally, the 7<sup>th</sup> CM2K circuit stops to operate, stops (turns off) the pump.  <b>Troubleshooting:</b> Call an authorized serviceman who will check the sensor position, check the damage/accuracy of the sensor and cable, check the contacts on the connectors, check the sensor's ohm resistance.</p>
<p>E114</p>	<p>CORRECTOR CM2K 7+ CIRCUIT</p>	<p><b>Possible cause:</b> Interruption in the cables between the 7<sup>th</sup> circuit corrector and CM2K, connections on the CM2K, cold junction or defective corrector  <b>Boiler status:</b> The boiler operates normally, the 7<sup>th</sup> CM2K circuit continues to operate as if the corrector is turned off.  <b>Troubleshooting:</b> Call an authorized serviceman who will check the corrector position, check the damage/accuracy of the corrector and cable, check the contacts on the connectors.</p>
<p>E115</p>	<p>SENSOR CM2K 8+ CIRCUIT</p>	<p><b>Possible cause:</b> Interruption in the cables between the 8<sup>th</sup> circuit sensor and CM2K, connections on the CM2K, cold junction or defective sensor.  <b>Boiler status:</b> The boiler operates normally, the 8<sup>th</sup> CM2K circuit stops to operate, stops (turns off) the pump.  <b>Troubleshooting:</b> Call an authorized serviceman who will check the sensor position, check the damage/accuracy of the sensor and cable, check the contacts on the connectors, check the sensor's ohm resistance.</p>
<p>E116</p>	<p>CORRECTOR CM2K 8+ CIRCUIT</p>	<p><b>Possible cause:</b> Interruption in the cables between the 8<sup>th</sup> circuit corrector and CM2K, connections on the CM2K, cold junction or defective corrector  <b>Boiler status:</b> The boiler operates normally, the 8<sup>th</sup> CM2K circuit continues to operate as if the corrector is turned off.  <b>Troubleshooting:</b> Call an authorized serviceman who will check the corrector position, check the damage/accuracy of the corrector and cable, check the contacts on the connectors.</p>

E117	NOT ACTIVE	
E118	NOT ACTIVE	
E119	FUEL SENSOR	<p><b>Possible cause:</b> Interruption in the cables between the sensor and controller, connections on the controller, cold junction or defective sensor.</p> <p><b>Boiler status:</b> Entering the extinguishing phase S7 (S7 – 1).</p> <p><b>Troubleshooting:</b> Call an authorized serviceman who will check the sensor position, check the damage/accuracy of the sensor and cable, check the contacts on the connectors.</p>
E120	ERROR FLAP NOT CLOSED	<p><b>Possible cause:</b> The vacuum suction flap is blocked with pellets, dirty or too far away flap sensor.</p> <p><b>Boiler status:</b> The boiler operates normally.</p> <p><b>Troubleshooting:</b> Check if the vacuum suction flap is blocked with pellets, check if the flap sensor is dirty with dust, check if the flap sensor has a 1 mm distance from the flap, check if the flap sensor responds to the flap (the LED light on the sensor lights).</p>
E121	NO PELLETS	<p><b>Possible cause:</b> No pellets in the pellet tank, blocked flexible tubes, the turbine net is filled with dust, the exit from the bigger tank is filled with dust.</p> <p><b>Boiler status:</b> The boiler operates normally.</p> <p><b>Troubleshooting:</b> Please check the pellet level in the tank, check if the flexible tubes are blocked, check if the turbine net is full with dust, check if the exit from the bigger tank is full with dust.</p>
E122	MOLE OR SCREW NOT WORKING	<p><b>Possible cause:</b> Interruption in the el. cables between the controller and the mole/screw (feeder) in the tank.</p> <p><b>Boiler status:</b> The boiler operates normally.</p> <p><b>Troubleshooting:</b> Call an authorized serviceman who will check the el. connections on the mole/screw(feeder) in the tank, check the contacts on the connectors.</p>
E123	NOT ACTIVE	
E124	NOT ACTIVE	

### 14.2 LIST AND TROUBLESHOOTING OF WARNINGS

<p><b>W1</b></p>	<p>FACTORY SETTING LOADED</p>	<p><b>Possible cause:</b> It occurs when the controller automatically loads the factory parameters as the data in the data base is faulty/incorrect. Under normal circumstances the warning occurs during the first start after changing the software. <b>Boiler status:</b> The boiler does not operate and it cannot continue to operate. <b>What needs to be done:</b> Call an authorized serviceman who has to make the first commissioning and set all parameters one more time.</p>
<p><b>W2</b></p>	<p>WRONG DATE AND TIME</p>	<p><b>Possible cause:</b> The hour resets to 00:00 and the date to 1.1.2000. after switching off the controller on the main switch or due to power outage. <b>Boiler status:</b> The boiler can operate (if the boiler switching times are used the E7 error occurs and the boiler does not operate). <b>What needs to be done:</b> It is necessary to change the battery on the controller screen (CR 1220), set the date and hour on the controller.</p>
<p><b>W3</b></p>	<p>LOW RETURN TEMPERATURE</p>	<p><b>Possible cause:</b> Problem with the mixing valve/actuator (safety of the return), return sensor. <b>Boiler status:</b> The boiler will continue to operate normally. <b>What needs to be done:</b> The cause needs to be removed as with a longer operation the boiler will condense and the flue gas passages will be blocked.</p>
<p><b>W4</b></p>	<p>FUEL LEVEL</p>	<p><b>Possible cause:</b> Low pellet level in the tank, the level is sufficient for a shorter boiler operation. <b>Boiler status:</b> The boiler will operate a certain time and if the tank will not be supplemented with pellets minimal above the fuel sensor level the error "E121 - no fuel" will appear which means that there are no pellets to continue the boiler operation any longer and the boiler will stop. <b>What needs to be done:</b> Fill the tank with pellets minimal above the fuel sensor level in the pellet tank.</p>
<p><b>W5</b></p>	<p>NOT ACTIVE</p>	
<p><b>W6</b></p>	<p>NOT ACTIVE</p>	
<p><b>W7</b></p>	<p>NOT ACTIVE</p>	
<p><b>W8</b></p>	<p>NOT ACTIVE</p>	

IW1-1	POWER DOWN	<p><b>Possible cause:</b> Power outage or switching off the controller on the main switch (0/1) unrelated in which operation phase the burner is in, including also the phase OFF.</p> <p><b>Boiler status:</b> The information is written in the warning history and is not announced on the screen. The record time is the moment of the power outage/switching off the controller on the main switch.</p>
IW1-2	POWER UP	<p><b>Possible cause:</b> Return of power or switching on the controller on the main switch (0/1).</p> <p><b>Boiler status:</b> The information is written in the warning history and is not announced on the screen. The record time is the moment of the power return/switching on the controller on the main switch.</p>
IW1-3	ENTERING INTO STATE F1	<p><b>Possible cause:</b> The tube backfilling sensor has signaled the backfilling of the pellet supply tube.</p> <p><b>Boiler status:</b> The information is written/recorded in the warning history and is not announced on the screen. It is factory active only for CPPL 90. The boiler operates in a special regime (reduces the pellet supply into the burner) with the goal to continue the work in a standard regime, if it fails during the set time the error E9_1 or E9_2 is notified.</p> <p><b>Troubleshooting:</b> Check the backfilling of the burner grate, burner combustion chamber, boiler combustion chamber, flue gas passages, backfilling of the flue and chimney, check if the burner grate is properly set in the burner (check that the burner grate is not set ON the electric heater – this is valid for CPPL 14 – 50), check if the pellets are too humid, inadequate dimensions or pellet quality (for this burner setting the diameter 6 mm), possible hole in the flexible tube, too big pellet supply (too low fan's rpm).</p>

## 15.0 MALFUNCTION / IPROPER BOILER OPERATION

### 15.1 SAFETY THERMOSTAT - boiler malfunction

On the boiler controller screen following error is announced (E 20 SAFETY THERMOSTAT OR DOOR MICROSWITCH), the boiler behaves itself according to the description of the error E20. If the cause of the E20 error is not the open boiler lower door, bad positioned microswitch along the lower boiler door (the microswitch is not sufficiently pressed when the door is closed), faulty microswitch along the lower boiler door – the cause of this error is a reached to high water temperature in the boiler (above 101°C) as the safety thermostat interrupts the burner fan operation and pellet feeder if the boiler temperature exceeds the maximum permitted temperature (110 – 9 °C).

For a reactivation of the safety thermostat (STB) following needs to be done:

- Wait until the boiler temperature falls below 70°C.
- Unscrew and take off the safety thermostat lid (detail A).
- Press the thermostat restart button (detail B).
- After pressing the thermostat restart button the fan error will be removed/eliminated, the boiler is ready for operation.
- In case the same problem occurs again during the first next boiler firing or if it occurs frequently, ask an advise from the authorized servicemen.

**Picture – Safety thermostat**

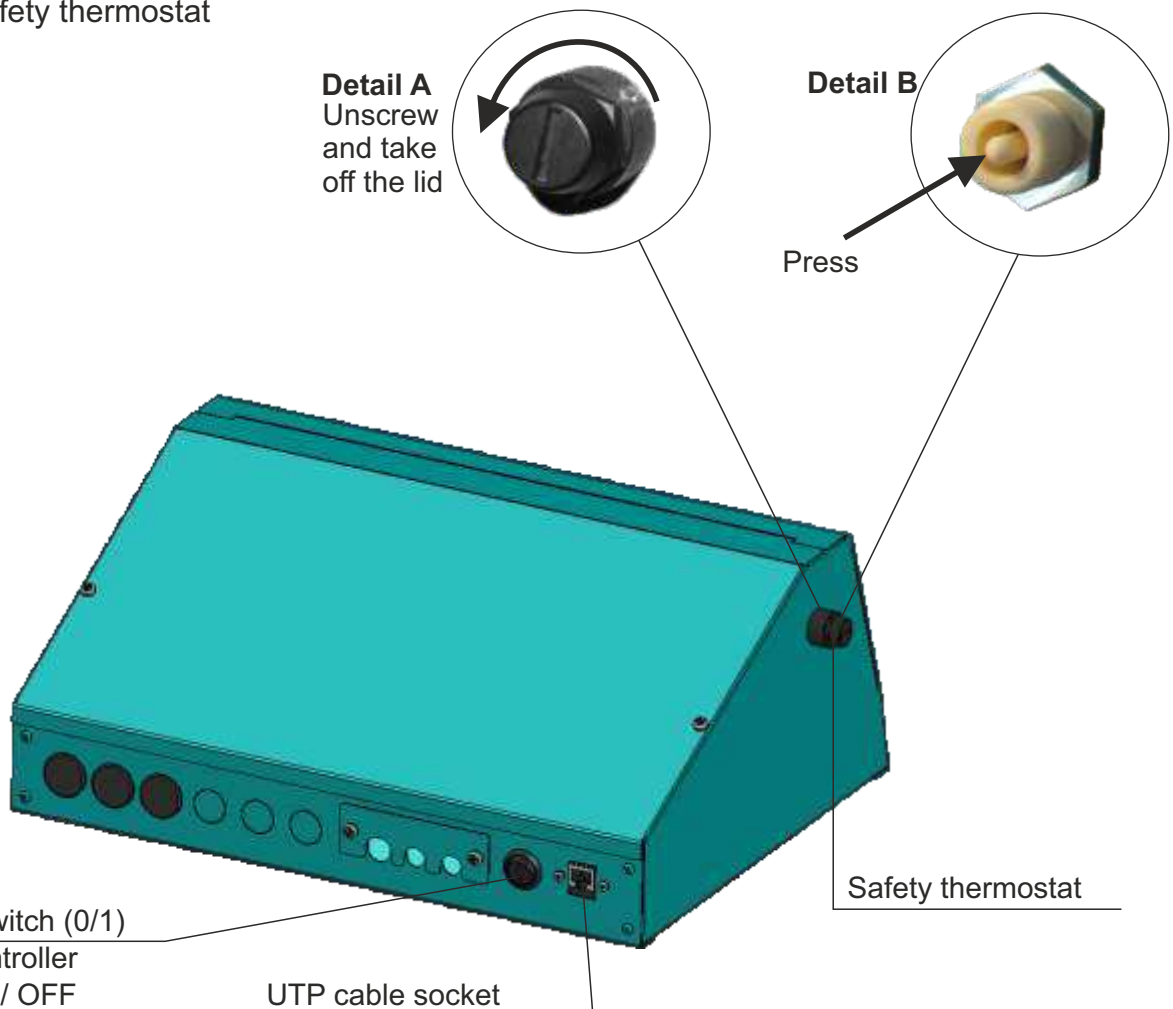

### **CAUTION!**

**If the thermostat frequently shuts down the fan please call an authorized serviceman to check the system.**

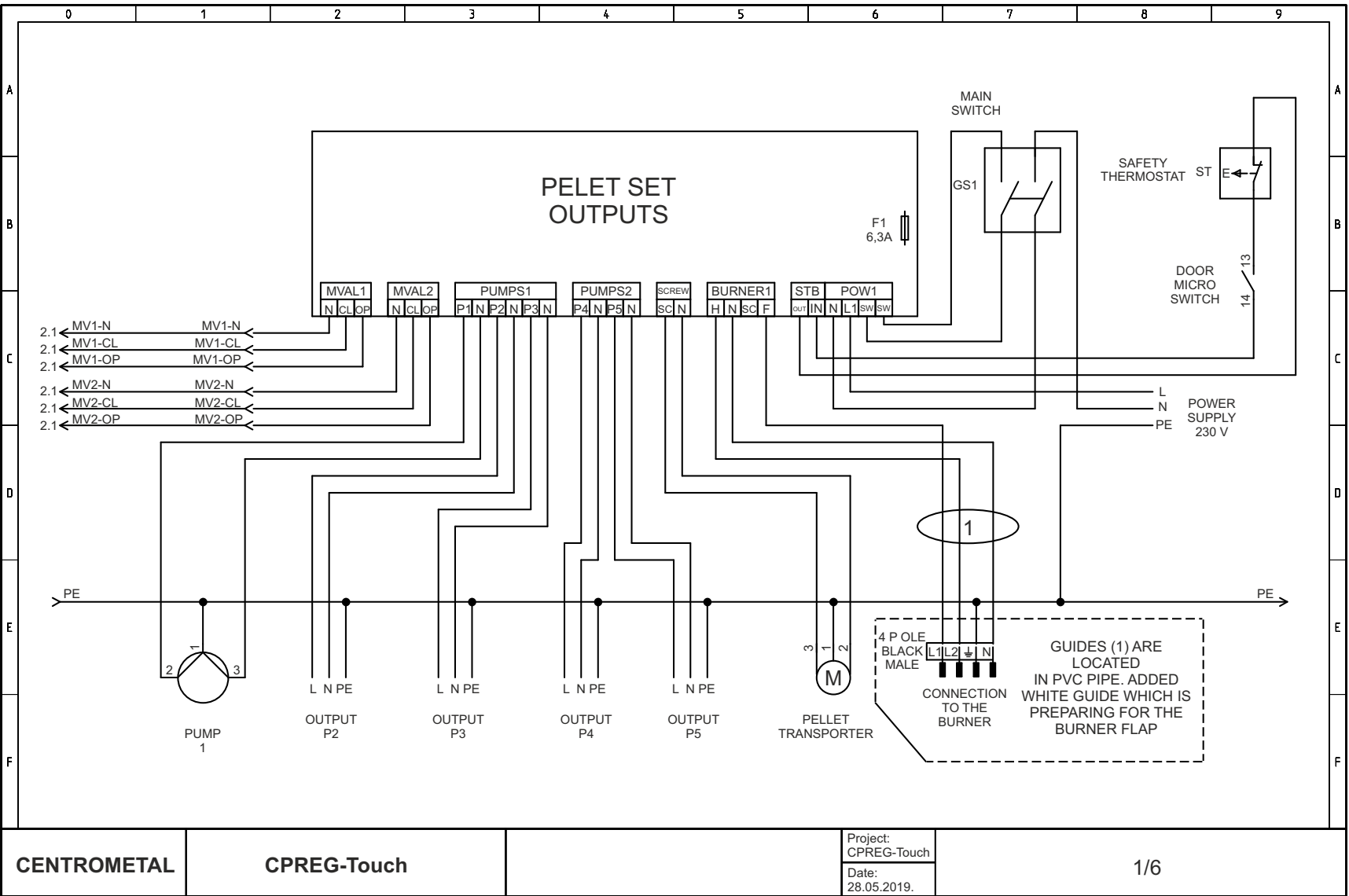

Note:  
 - outputs P2 – P5 can be configured as pumps outputs or (as) outputs for additional equipment (air cleaning and fan flap, and it must be selected, in the controller, which output is used for which additional equipment)  
 - if all pump outputs are already in use, and there is also additional equipment, it is necessary to connect an additional electronic plate to the controller or reconnect some of the pumps to the CMZK module

**ELECTRIC SCHEME 2/6**

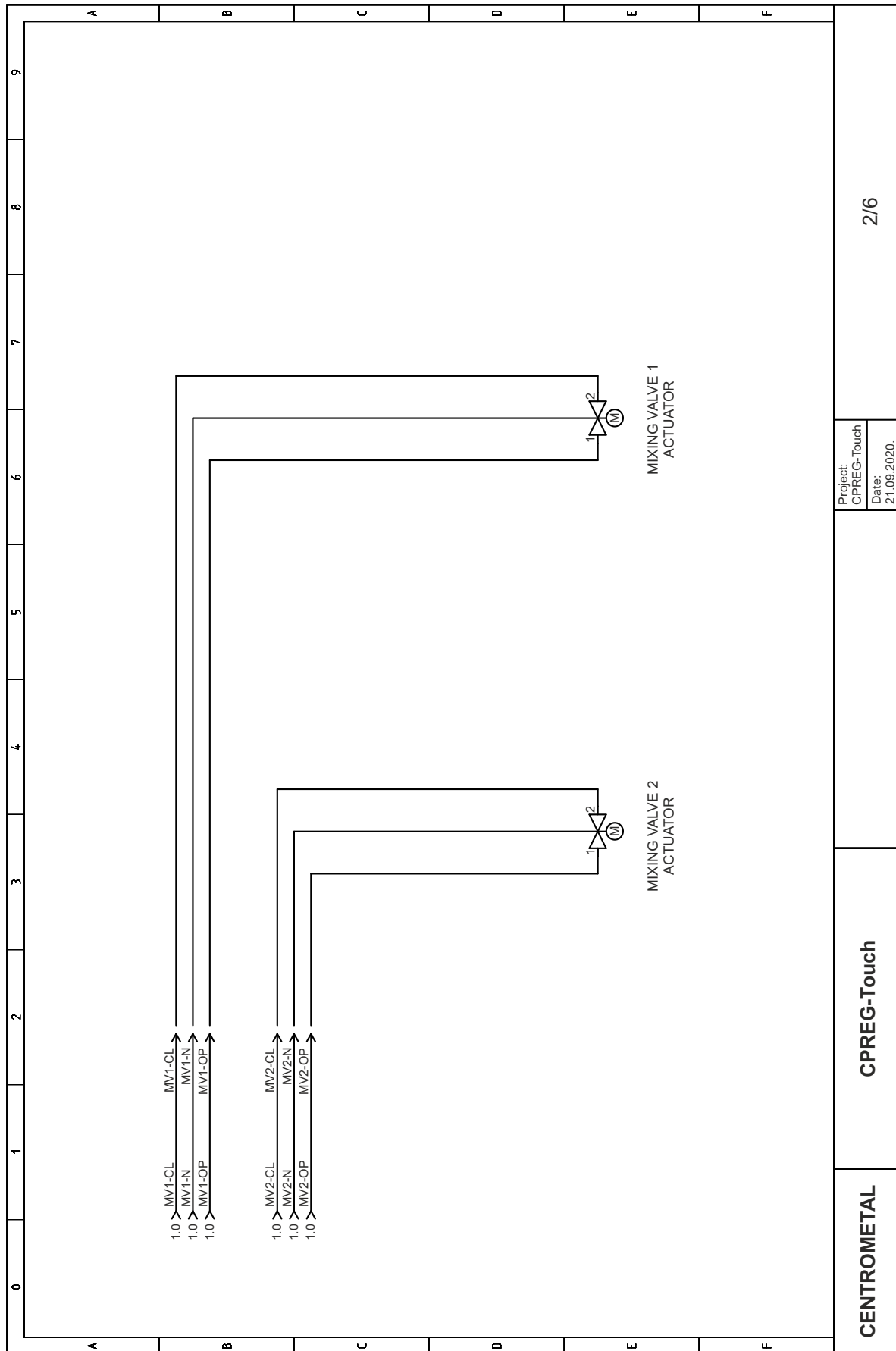

<b>CENTROMETAL</b>	<b>CPREG-Touch</b>	Project: CPREG-Touch	2/6
		Date: 21.09.2020.	

Note:  
- this outputs can be used for heating circuits motor actuators, 3-way mixing valves or 4-way mixing valve in boiler return protection

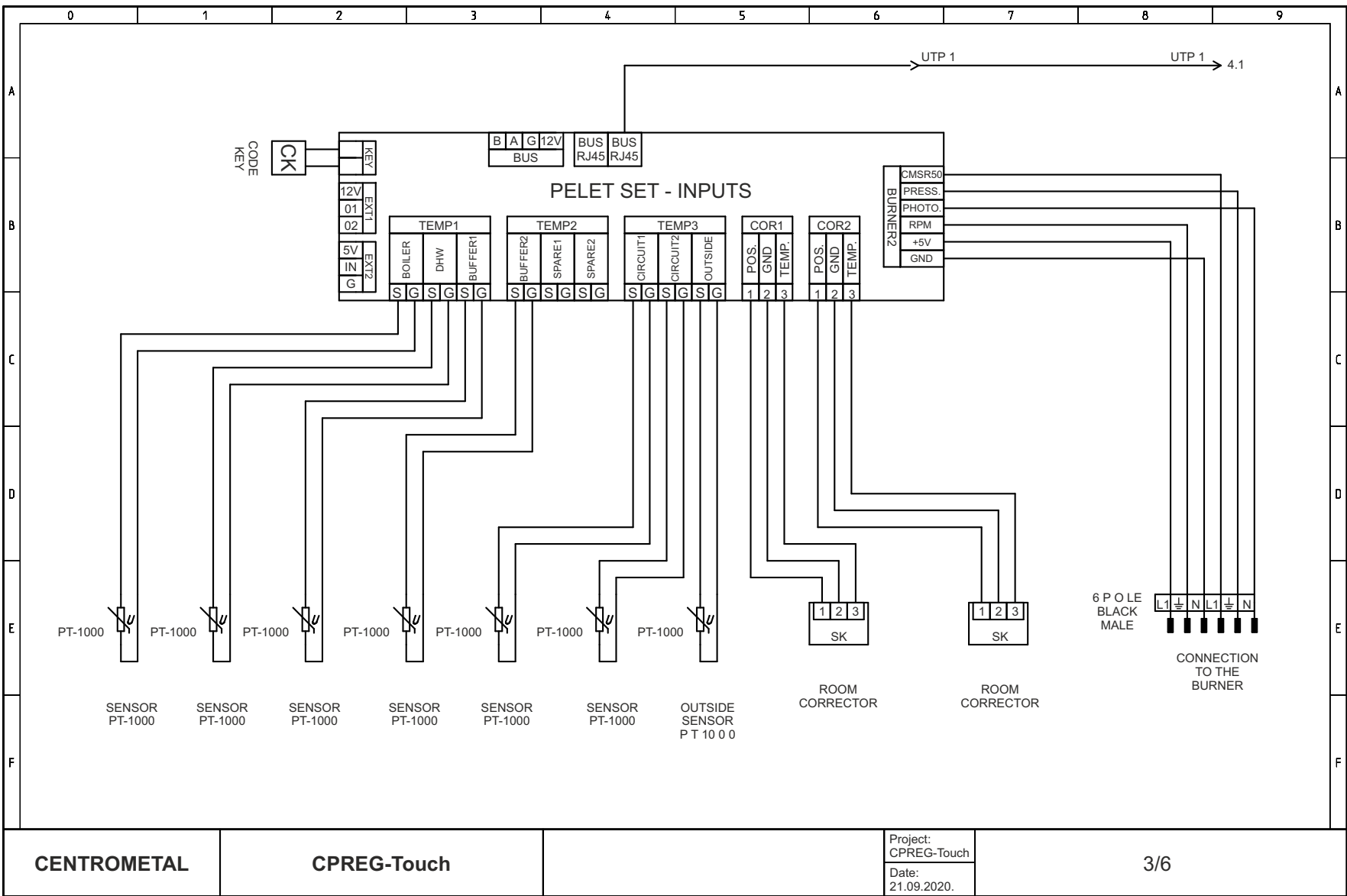

Note:  
- the controller is set, by default, to use PT1000 sensors (if necessary it can be configured to use NTC5K sensors – can be configured by an authorized serviceman only)

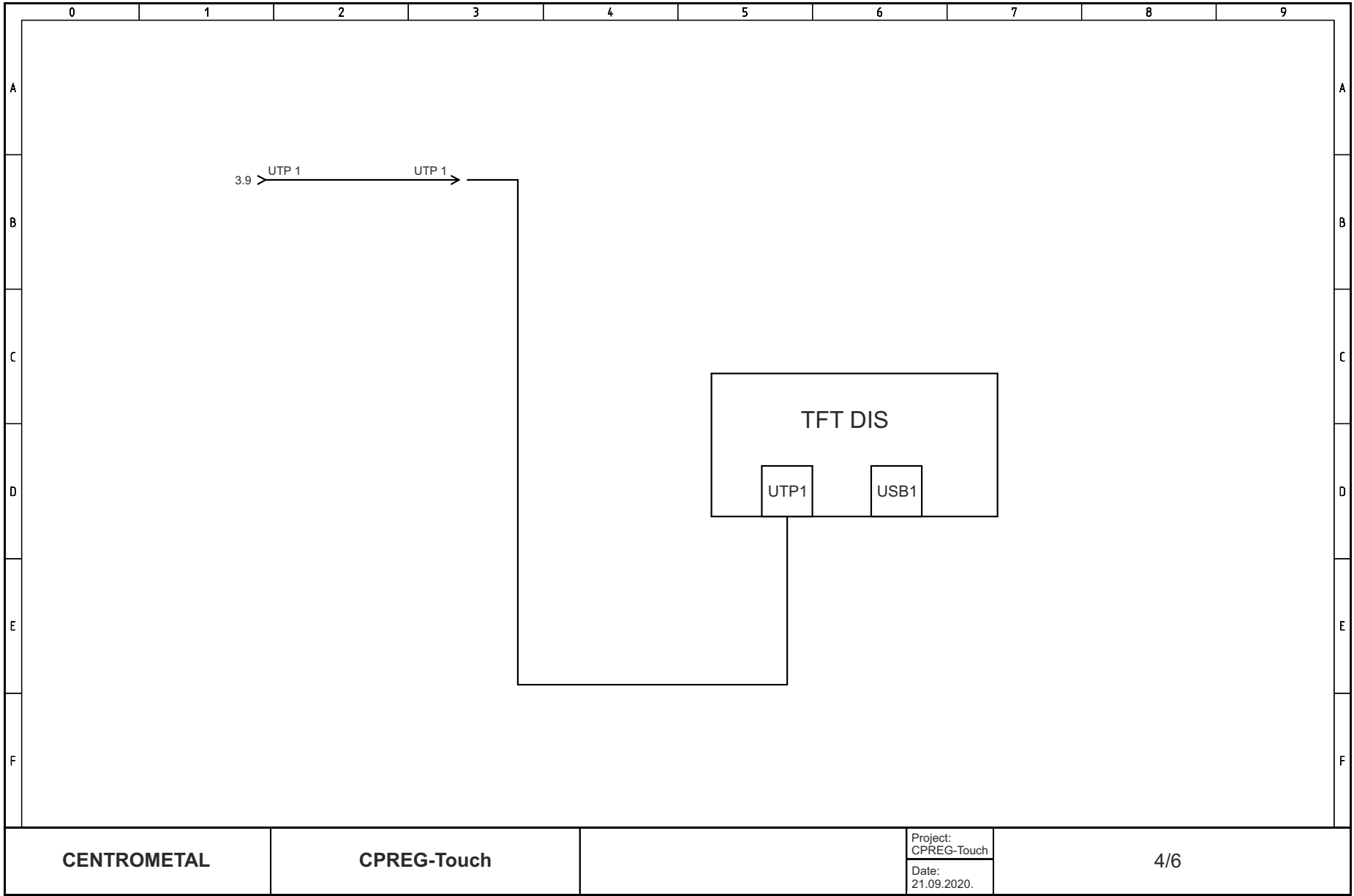

**ELECTRIC SCHEME 5/6**

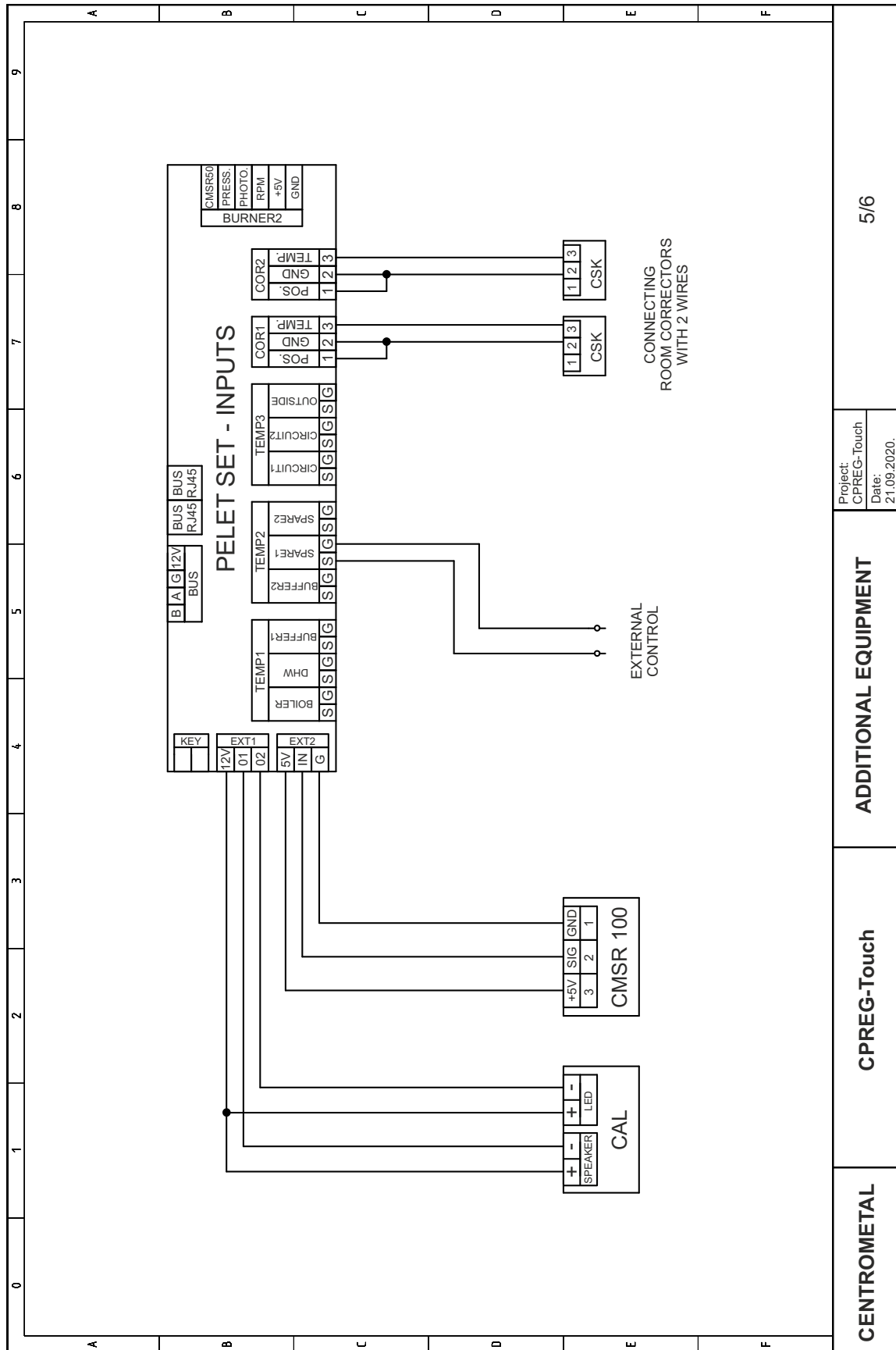

5/6

Project: CPREG-Touch  
Date: 21.09.2020.

**ADDITIONAL EQUIPMENT**

**CPREG-Touch**

**CENTROMETAL**

- Note:
- when connecting room correctors with only 2 wires, possibility of room temperature correction is lost (any correction must be done on the boiler regulation or trough WEB PORTAL)
  - regarding the firmware version, on older version resistor 6,5K must be installed between inputs 1 (POS) and 2 (GND) so correction is 0; while in newer firmware version room corrector connection with 2 or 3 wires can be selected and it not needed to install resistor

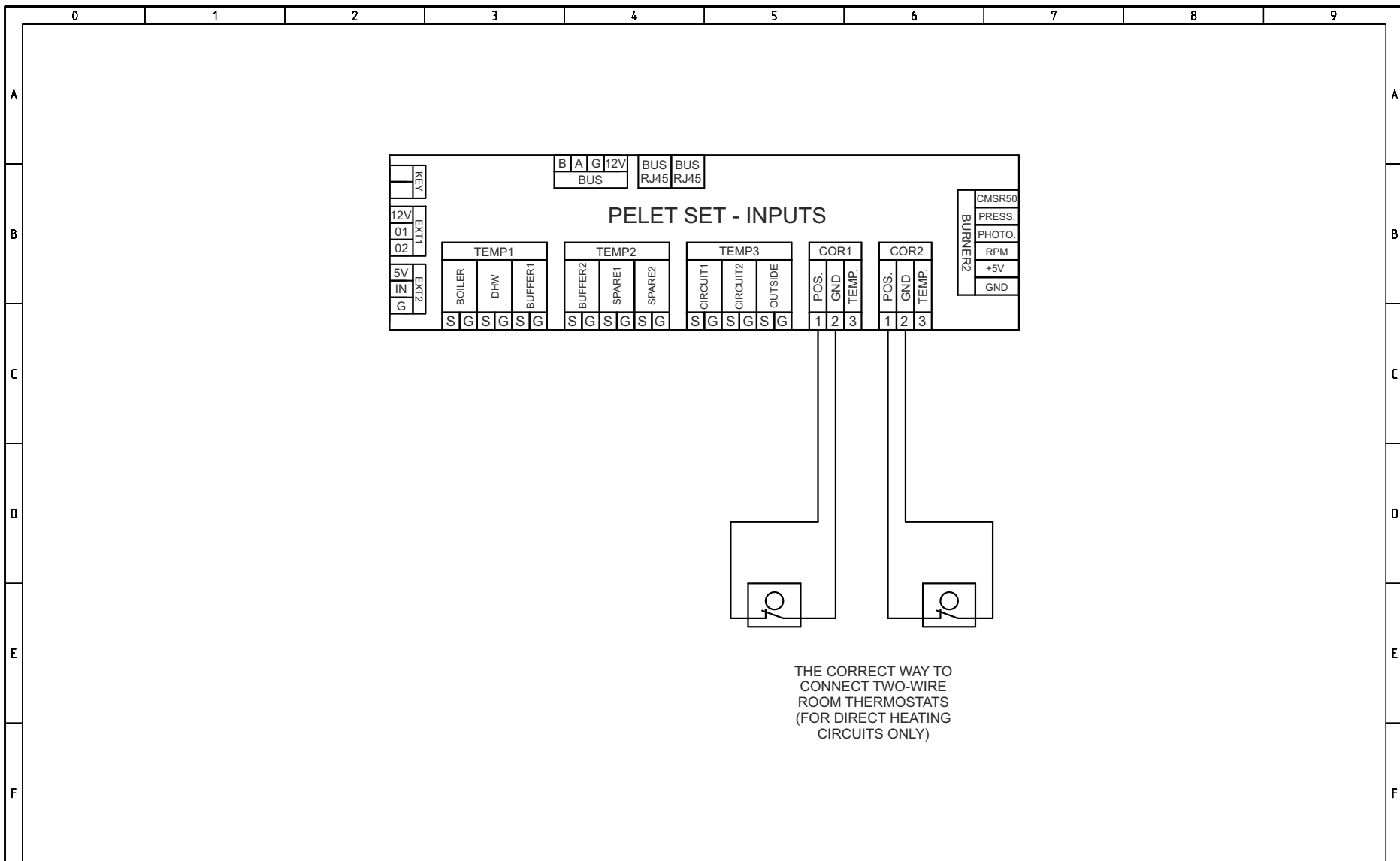

CENTROMETAL

CPREG-Touch

ROOM THERMOSTAT

Project:  
CPREG-Touch  
Date:  
21.09.2020.

6/6

TABLE WITH RESISTANCE NTC 5k/25 °C  
SENSOR  
(range -20 to +130 °C)

Temperature (°C)	Resist. (W)
-20	48.535
-15	36.465
-10	27.665
-5	21.158
0	16.325
5	12.694
10	9.950
15	7.854
20	6.245
25	5.000
30	4.028
35	3.266
40	2.663
45	2.184
50	1.801
55	1.493
60	1.244
65	1.041
70	876
75	740,7
80	629,0
85	536,2
90	458,8
95	394,3
100	340,0
105	294,3
110	255,6
115	222,7
120	190,7
125	170,8
130	150,5

TABLE WITH RESISTANCE Pt1000  
SENSOR  
(range -30 to +400 °C)

Temp. (°C)	Resist. (W)	Temp (°C)	Resist. (W)
-30	885	190	1.732
-25	904	195	1.751
-20	923	200	1.770
-15	942	205	1.789
-10	962	210	1.809
-5	981	215	1.828
0	1.000	220	1.847
5	1.019	225	1.866
10	1.039	230	1.886
15	1.058	235	1.905
20	1.077	240	1.924
25	1.096	245	1.943
30	1.116	250	1.963
35	1.135	255	1.982
40	1.154	260	2.001
45	1.173	265	2.020
50	1.193	270	2.040
55	1.212	275	2.059
60	1.231	280	2.078
65	1.250	285	2.097
70	1.270	290	2.117
75	1.289	295	2.136
80	1.308	300	2.155
85	1.327	305	2.174
90	1.347	310	2.194
95	1.366	315	2.213
100	1.385	320	.2323
105	1.404	325	2.251
110	1.424	330	2.271
115	1.443	335	2.290
120	1.462	340	2.309
125	1.481	345	2.328
130	1.501	350	2.348
135	1.520	355	2.367
140	1.539	360	2.386
145	1.558	365	2.405
150	1.578	370	2.425
155	1.597	375	2.444
160	1.161	380	2.463
165	1.635	385	2.482
170	1.655	390	2.502
175	1.674	395	2.521
180	1.693	400	2.540
185	1.712		



**EC IZJAVA O SUKLADNOSTI**  
**EC DECLARATION OF CONFORMITY**

Organizacija:  
Manufacturer:  
Naziv i adresa:  
Name and address:  
**Centrometal d.o.o.**  
**III-40335 Madunac, Glavna 14, Ulica 14**

Ja sam odgovoran/odgovorna, izjavljujem, da:  
We declare under our sole responsibility that:

proizvod:  
Product designation:  
tip / model:  
Type / model:  
**Aspirantni kladivo sa dvije pelete (za namenu kućnog upotrebe) (pellet)**  
**Electric wood chisel (for domestic use) (pellet)**  
**EMO-CK (B) P + Cm Pellet-set (14-40 + 40)**

odgovara zahtjevima sljedećih  
propisa  
Is in conformity with the provisions of the following regulations:

- |    |  |
|----|--|
| 1. | EMC Direktiva 2006/42/EC<br>EMC Directive 2006/42/EC |
| 2. | LVD Direktiva 2014/35/EU<br>LVD Directive 2014/35/EU |
| 3. | EMC Direktiva 2014/53/EU<br>EMC Directive 2014/53/EU |

U skladu zadovoljava zahtjeve sljedećih standardi  
and also complies with the following standards:

EMC Direktiva 2006/42/EC	EN 60335-1:2012/AC:2014; EN 60335-2-29:2006/94:2010, EN 60335-2008
LVD Direktiva 2014/35/EU	EN 60335-1:2012, EN 60335-2-29:2014, EN 60335-3-2:2014, EN 61000-6-2 i -3:2014; EN 61000-6-3:2007
EMC Direktiva 2014/53/EU	EN 55015:2012
MU Direktiva 2006/42/EC	

Godina izdavanja CE oznake: 2024.  
Year of affixing of CE marking:

Mjesto i datum izdavanja  
Place and date of issue:

Maestri, 31.10.2024.

Ime, prezime i potpis ovlaštene osobe  
Name, surname and signature of authorized person:  
Thomas Zidarić

**Centrometal** d.o.o.  
© 2024. MAESTRI s.d. - od 1992.  
Twitter: @centrometal, Facebook: centrometal



**WiFi**  
READY



Company assumes no responsibility for possible inaccuracies in this book originated typographical errors or rewriting, all the pictures and diagrams are principal and it is necessary to adjust each actual situation on the field, in any case the company reserves the right to enter their own products such modifications as considered necessary.

**Centrometal d.o.o. Glavna 12, 40306 Macinec, Croatia**

central tel: +385 40 372 600, fax: +385 40 372 611  
service: +385 40 372 622, fax: +385 40 372 621

**www.centrometal.hr**  
**e-mail: servis@centrometal.hr**

**Centrometal**  
HEATING TECHNIQUE