



---

Environmental Combustion and Control

**Stryker BACnet VAV System Engineering Guide**

May 2016



31-00105-01



## References

Sr. No.	Document	Form No.
1	Stryker™ BACnet Configurable VAV Controller Specification Data	31-00100
2	Stryker™ BACnet Configurable VAV Controller Installation Instructions	31-00101
3	Zio® / Zio Plus LCD Wall Modules: TR70, TR71 and TR75 models with Sylk® bus Installation Instructions	62-0271-09
4	Zio®/Zio Plus LCD Wall Modules: TR70, TR71, TR75 with Sylk® Bus Specification Data	63-1322-03
5	Zio®/Zio Plus LCD Wall Modules: TR70, TR71, TR75 with Sylk® Bus Specification Data	63-2719-04
6	TR21, TR22, TR23, and TR24 Wall Modules Specification Data	63-1321ES-06
7	TR21, TR22, TR23, and TR24 Wall Modules Installation Instructions	62-0267-09
8	Sensor Selection Guide	63-9285 PR
9	TR21, TR22, TR23, and TR24 Wall Modules Specification Data	63-1321ES-06

# Table of Contents

<b>INTRODUCTION .....</b>	<b>6</b>
Overview of Stryker BACnet VAV Controller .....	6
Control Applications.....	6
Control Provided.....	8
Features.....	11
Abbreviations .....	13
<b>APPLICATION STEPS .....</b>	<b>14</b>
Plan the System.....	14
Hardware Design.....	14
Place the order .....	14
List of Accessories.....	14
Installation and Wiring.....	15
Configuration and Testing of the VAV Controller .....	15
<b>HARDWARE.....</b>	<b>16</b>
VAV Controller (CVB4024NS-VAV1 and CVB4022AS-VAV1).....	16
Specifications.....	16
Status Information.....	17
Communications.....	17
Mounting .....	18
Piping.....	21
Power.....	22
Wiring.....	24
Checkout.....	31
<b>SOFTWARE.....</b>	<b>34</b>
Introduction.....	34
VAV Configuration Requirement.....	34
Configuration.....	34
Share Wall Module.....	39
Accessory Loops.....	40
PID Control.....	40
Proportional Control.....	40
Integral Control .....	41
Derivative Control.....	42
Control Loop Inputs .....	43
Accessory Loop Outputs.....	43
Output Operation.....	43
Effective Setpoint Calculation.....	45
Effective Setpoint.....	45
Setpoint Reset.....	45
Control Loop Inputs .....	45
Accessory Loop Examples .....	45
Flow Balancing.....	49
Balancing using the Niagara Tool .....	49
Heating coil water flow calibration.....	50
Balancing via Zio.....	50

Alarm Reporting.....	51
Fault Handling in the Controller.....	54
Fault Tolerance.....	54
BACnet Objects.....	55
Configurable Inputs.....	55
Variable Input.....	85
Variable Output.....	94
<b>APPENDIX.....</b>	<b>117</b>
Common Operations.....	117
Room Temperature Sensor (RmTemp).....	117
Center Setpoint.....	117
Bypass Mode.....	117
Bypass Time.....	117
Override Type (conventional wall modules).....	117
Zio Override.....	118
Override Priority.....	118
Occupancy sensor.....	118
Window Sensor.....	118
Continuous Unoccupied Mode (conventional wall modules).....	118
Share Wall Module.....	118
Night Purge.....	118
Morning Warm-Up.....	118
Smoke Control.....	119
Demand Limit Control.....	119
Start-Up and actuator synchronization.....	119
CO <sub>2</sub> Ventilation.....	119
Automatic Heat-Cool changeover based on Supply Temperature.....	119
Airflow Control Sequences of Operation.....	119
Flow Tracking.....	119

## List of Tables

Table 1: Controller Configurations.....	6
Table 2: Modes of Operation for CVB Controller.....	8
Table 3: Capabilities of CVB controllers .....	11
Table 4: Accessories List.....	14
Table 5: Universal Input Circuit Specifications.....	17
Table 6: LED States.....	17
Table 7: Power Budget Calculation Example.....	22
Table 8: VA Ratings for Transformer Sizing .....	23
Table 9: Honeywell Transformers that meet NEMA Standard DC20-1986.....	24
Table 10: Description of Wiring Terminal Connections .....	28
Table 11: DIP Switch Values for MS/TP MAC Address .....	29
Table 12: Status LED States.....	31
Table 13: BACnet Status LED States .....	32
Table 14: Configuration Options .....	34
Table 15: Mapping of Error conditions to Alarm IDs.....	52
Table 16: Fault Tolerance .....	54
Table 17: Local Input Configuration.....	55
Table 18: Logical Inputs Enumeration .....	60
Table 19: Logical Inputs Enumeration .....	61
Table 20: Local Output Configuration .....	72
Table 21: Logical Outputs Enumeration Description .....	74
Table 22: Logical Outputs Configuration.....	75
Table 23: Logical Outputs Enumeration Description .....	85
Table 24: Variable Outputs .....	94
Table 25: Configuration Parameters.....	102

# List of Figures

Figure 1: Typical CVB4024NS-VAV1 box control application ..... 7

Figure 2: Typical CVB4022AS-VAV1 box control application ..... 7

Figure 3: Series 60 Floating Actuator ..... 18

Figure 4: Damper with 90 degree CW rotation to open ..... 18

Figure 5: Determining the rotation direction (CW or CCW) for damper opening ..... 19

Figure 6: Panel mounting - controller dimensions in inches (mm) for CVB4024NS-VAV1 only ..... 20

Figure 7: Mounting - controller and actuator dimensions in inches (mm) for CVB4022AS-VAV1 only ..... 20

Figure 8: Controller DIN rail mounting (CVB4024NS-VAV1) ..... 20

Figure 9: Airflow pickup connections ..... 21

Figure 10: NEMA Class 2 transformer voltage output limits ..... 24

Figure 11: Power Wiring details for one Controller ..... 25

Figure 12: Transformer power wiring details for one controller used in UL 1995 equipment (U.S. only) ..... 25

Figure 13: Power Wiring details for one Controller per Transformer ..... 26

Figure 14: Transformer power wiring details for one controller used in UL 1995 equipment (U.S. only) ..... 26

Figure 15: Power Wiring details for two or more Controllers per Transformer ..... 27

Figure 16: Termination Modules ..... 27

Figure 17: Attaching two or more wires at terminal blocks ..... 28

Figure 18: Controller wiring diagram for typical VAV application, using the TR23 wall module ..... 30

Figure 19: Controller wiring diagram for typical VAV application with staged reheat ..... 30

Figure 20: Removing Terminal Blocks ..... 33

Figure 21: VAV box modes for Reheat Type Elec\_ThreeStage - Proportional ..... 35

Figure 22: VAV box modes for Reheat Type Elec\_ThreeStage - Non-Proportional ..... 35

Figure 23: VAV box modes for Reheat type Peripheral Heating Then Reheat - Proportional  
(Float\_Periph\_Reheat/PWM\_Periph\_Reheat) ..... 36

Figure 24: VAV box modes for Reheat Type Elec\_ThreeStage - Non-Proportional ..... 36

Figure 25: VAV box modes for Reheat type Peripheral Heating Then Reheat Discharge Air Control  
Sequence - Proportional ..... 36

Figure 26: VAV box modes for Reheat Type Float\_Reheat/ Float\_Periph, no minimum position, reheat goes to zero  
percent in cooling mode Non-proportional (suited for Reheat control because the Reheat closes to zero  
percent at HeatOccSpt) ..... 36

Figure 27: VAV box modes for Pressure Dependent, Reheat Type Float Reheat/Float\_Periph ..... 37

Figure 28: Series VAV box fan ..... 37

Figure 29: Parallel VAV Box Fan ..... 37

Figure 30: Single Duct, Pressure Independent Cooling, with Analog Parallel Fan ..... 37

Figure 31: Modes for Single Duct, Pressure Independent Cooling, with Parallel Fan ..... 38

Figure 32: Exhaust Tracking Flow Control ..... 39

Figure 33: Proportional Direct Acting (Cooling) ..... 40

Figure 34: Proportional Reverse Acting (Heating) ..... 40

Figure 35: Proportional Integral Control ..... 41

Figure 36: Proportional Control ..... 42

Figure 37: Proportional Integral Control ..... 42

Figure 38: Proportional Integral Derivative Control ..... 42

# INTRODUCTION

## Overview of Stryker BACnet VAV Controller

The Stryker BACnet VAV (CVB) Controllers are configurable direct digital controllers designed for pressure independent or pressure dependent single duct air terminal unit control solutions. The controllers feature preprogrammed heating/cooling or reheat control algorithms for VAV Box control applications. They can be configured to match a wide range of VAV applications. They use BACnet® communication technology for greater installation flexibility.

Two models of the CVB controller are available, CVB4022AS-VAV1 and CVB4024NS-VAV1. The CVB4022AS-VAV1 model consists of a controller and an in-built floating actuator for damper control. The CVB4024NS-VAV1 model does not include an actuator. Both models contain an integral Micro-bridge airflow sensor that provides flow measurement for pressure independent applications.

The CVB controller controls the space temperature in a given zone by modulating a damper and/or regulating a reheat coil in a Variable Air Volume Box that delivers air to a space.

The controller is capable of stand-alone operation; however, optimum functional benefits are achieved when the network communication capabilities are used.

The Zio (TR71/TR75 only) and TR2x series of wall modules are used in conjunction with the CVB Controllers. Zio is the first LCD Wall Module to communicate via a two-wire, polarity insensitive bus with the Honeywell Spyder and Stryker controller families. The CVB controllers can be configured in Zio.

**Table 1: Controller Configurations**

Controller Model	Communication Protocol	Application	UI (Universal Input)	DI (Digital Input)	AO (Analog Output)	DO (Digital Output)	Velocity Pressure Sensor (Micro-bridge)	Series 60 Floating Actuator
CVB4022 AS-VAV1	BACnet	VAV	4	0	2	2	YES	YES
CVB4024 NS-VAV1	BACnet	VAV	4	0	2	4	YES	NO

## Control Applications

VAV systems in commercial buildings typically incorporate a central air handler that delivers a modulated volume of air at a preconditioned temperature to multiple zones. A VAV terminal box unit serves each zone. Each box incorporates an airflow pickup assembly and motorized damper with optional fan and/or reheat coil. The controller determines and regulates the airflow of conditioned air to the zone. The zone being served by the terminal box will use a TR2X Wall Module or a Zio (TR71/TR75 only) Digital Wall Module for space temperature determination and access to the BACnet network for operators.

Figure 1 shows a typical VAV box control application for the CVB4024NS-VAV1 controller. Figure 2 shows a typical VAV box control application for the CVB4022AS-VAV1 controller. Table 3 shows the capabilities of the CVB controllers.



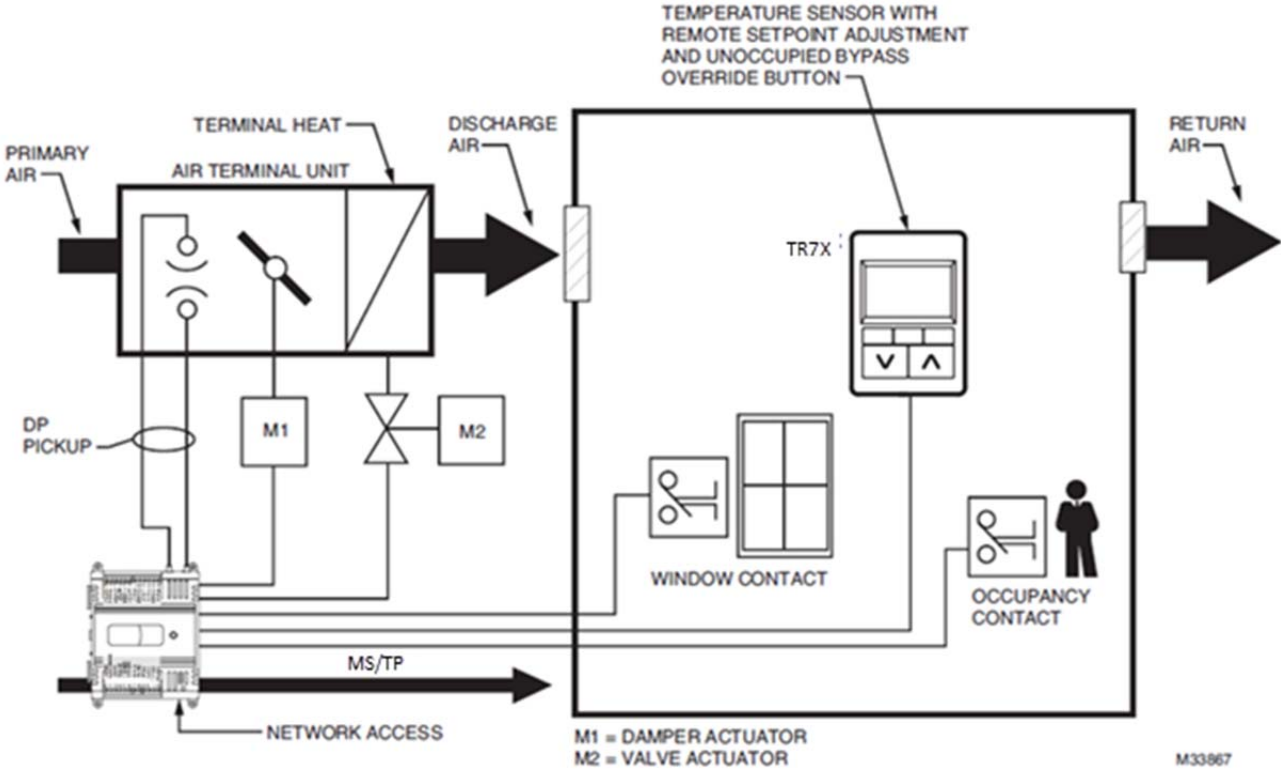

Figure 1: Typical CVB4024NS-VAV1 box control application

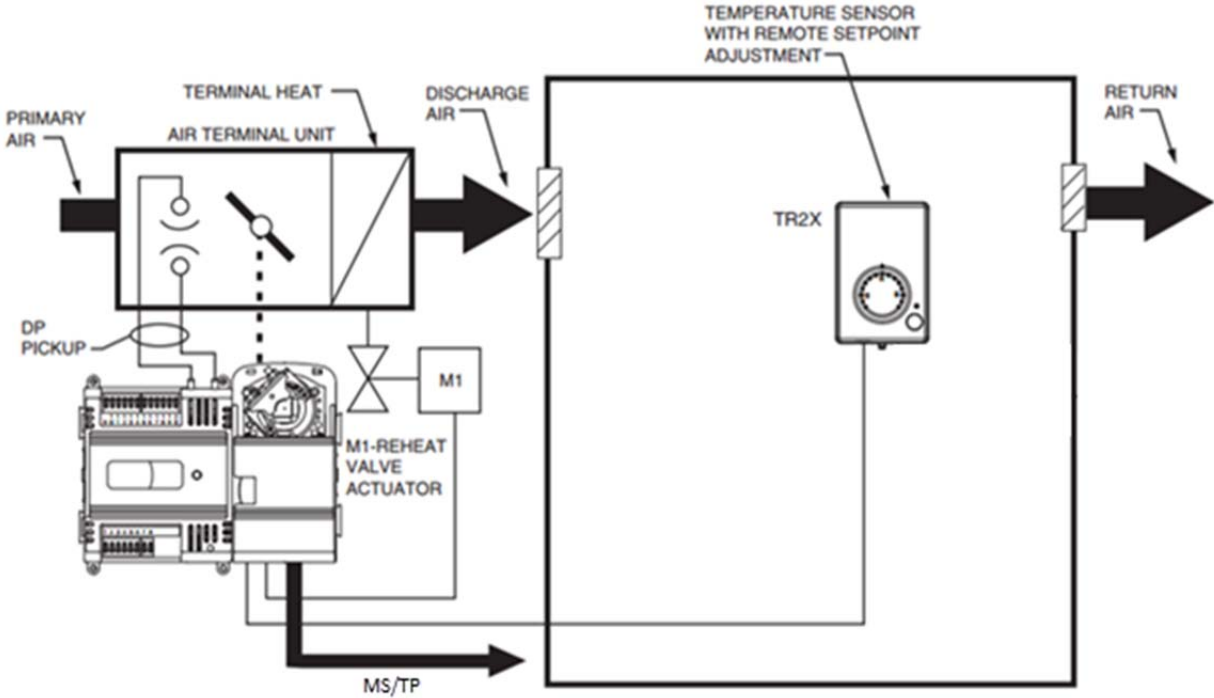

Figure 2: Typical CVB4022AS-VAV1 box control application

## Control Provided

The CVB Controllers are primarily intended for pressure independent, single duct VAV box control. Pressure independent control specifies that the individual zone terminal unit have a means for maintaining a consistent volume of air into the zone regardless of the input static pressure. The controller modulates the airflow into the zone to satisfy the Zone Temperature Setpoint. Minimum Airflow is maintained except during emergency strategy periods or during building unoccupied periods if using physical position stops, a MIN/MAX airflow is always maintained (Refer to [Table 2](#)).

Pressure dependent control specifies that the damper position is controlled by space temperature only and not by a measurement of airflow volume. The amount of air delivered to the zone at any given damper position is dependent on the static pressure in the supply air duct (physical position stops, range stop pins, are used to keep the damper at a fixed position). Additional outputs are available for control of heating systems such as reheat coils for Heat mode or Morning warm-up mode operation. The heating equipment can be staged- resistive heating, staged 2-position (solenoid) valve, or modulated steam or hot water valve.

**Table 2: Modes of Operation for CVB Controller**

Mode	Description	Events Causing a Controller to Switch to This Mode
<b>Effective Occupancy</b>		
OCCUPIED	Controller is in Occupied mode	Any of the following: <ol style="list-style-type: none"> <li>1. Local schedule state Zio wall module schedule.</li> <li>2. BACnet object [TodEventCurrStateIn (AV-1215)] containing time- of-day schedule, an occupancy sensor field input.</li> <li>3. Flag from either an Occupancy Sensor Digital Input.</li> <li>4. From the BACnet object [ManOccln (AV- 1196)] for manual override to OCCUPIED mode.</li> </ol>
STANDBY	Controller is in Standby mode.	Any of the following: <ol style="list-style-type: none"> <li>1. Local schedule</li> <li>2. BACnet object (TodEventCurrStateIn) containing time-of-day schedule</li> <li>3. Flag from the network must be OCCUPIED</li> <li>4. The Occupancy Sensor Digital Input must be UNOCCUPIED.</li> </ol>
UNOCCUPIED	Controller is in Unoccupied mode.	Any of the following: <ol style="list-style-type: none"> <li>1. Local schedule</li> <li>2. BACnet object(TodEventCurrStateIn) containing time-of-day schedule</li> <li>3. Flag from either an Occupancy Sensor Digital Input</li> <li>4. From the BACnet object [ManOccln (AV- 1196)] has a value of UNOCCUPIED.</li> </ol>
<b>Override Modes</b>		
OCCUPIED	Controller is in Occupied mode.	Any of the following: <ol style="list-style-type: none"> <li>1. BACnet object(TodEventCurrStateIn) containing time-of-day schedule</li> <li>2. Flag from the BACnet object [ManOccln (AV- 1196)] for manual override to OCCUPIED mode.</li> </ol>

Mode	Description	Events Causing a Controller to Switch to This Mode
UNOCCUPIED	Controller is in Unoccupied mode.	Any of the following: 1. BACnet object(TodEventCurrStateIn) containing time-of-day schedule 2. Flag from the BACnet object [ManOccln (AV-1196)] has a value of UNOCCUPIED.
BYPASS	User-initiated Bypass of the Unoccupied mode	Digital input (wall module override push button) has been pressed OR Override initiated from Zio and the Bypass duration timer has not yet expired, or the BACnet object ByPassIn received.
NOT ASSIGNED	No Bypass action	No Override input received.
<b>Operational Modes</b>		
START-UP AND WAIT (followed by)	Configurable flow Diversity on power-up provides a staggered start sequence to evenly apply the load to the supply fan and electrical system.	These modes occur on controller power-up, and after downloading to the controller from the tool or going to auto mode from manual mode. Temperature and flow control loops are disabled.
COOLING	The VAV Controller is controlling the Cooling mode.	BACnet object ApplicModeln [(AV-1471) =3] containing AHU operational mode information from other BACnet controllers that have the value of COOL (Reheat locked out).
HEATING	The VAV Controller is controlling the Heating mode.	BACnet object ApplicModeln [(AV-1471) =1] containing AHU operational mode information from other BACnet controllers that have the value of HEAT (Reheat is Enabled). Unit switches to Heat mode when warm air is supplied to the terminal unit.
REHEAT	The VAV Controller is controlling the Reheating mode.	BACnet object ApplicModeln has the value of AUTO. When cool air is supplied to the box and the space temperature is below the effective Heat Setpoint, the control algorithm will energize the Reheat coil(s).
MORNING WARMUP	The main AHU is supplying warm air and the box damper is set at (WarmupDmprPos)	BACnet object ApplicModeln (AV-1471) =2 containing AHU operational mode information from BACnet controllers that have the value of MORNING WARM-UP. Warm air is supplied to VAV boxes and reheats will follow CfgMorningWarmupType (AV1332). 1. <b>CfgMorningWarmupType</b> = 0 (Mixed Air) Temperature control is turned off and box damper goes to warmup position/flow 2. <b>CfgMorningWarmupType</b> = 1 (Warm Air With Reheat) Temperature control is reverse acting and reheat maybe commanded on (Reheat and Peripheral heat are enabled). 3. <b>CfgMorningWarmupType</b> = 2 (Warm Air Without Reheat) Temperature control is reverse acting and Peripheral heat maybe commanded on (Reheat disabled and Peripheral heat enabled).

STRYKER VAV CONTROLLER

Mode	Description	Events Causing a Controller to Switch to This Mode
NIGHT PURGE	The main AHU is supplying fresh (100 percent outdoor) air, and box damper is set at (PurgeDmprPos)	BACnet object ApplicModeln (AV-1471) = 4 containing AHU operational mode information from BACnet controllers that have the value of NIGHT PURGE.
FLOW TRACKING	Temperature control is turned off. The box maintains a Flow Setpoint based on the sum of all of the controllers supplying the zone (the source controller provides other controllers with FlowTrackOut (AV-1148)).	Configuration parameter is box type (Flow_Tracking). 'CfgTrackModeOffset [(AV-1326)]' (Flow Offset) determines the differential between the boxes that are the supply airflow and the exhaust airflow.
MANUAL POSITION	Box damper is set to manual position.	Typically is typically triggered during airflow balancing
MANUAL FLOW	Flow is controlled to manual value	Typically is typically triggered during airflow balancing
FREEZE PROTECTION	Controller is in freeze protection mode. Heating setpoint is reset to freeze protection setpoint.	Window is open
EMERGENCY PRESSURIZE	move the damper to the emergency pressurize position, Fan disabled	Emergency network command received [EmergCmdIn (AV-1182) =1]
EMERGENCY DEPRESSURIZE	move the damper to the emergency depressurize position, Fan disabled	Emergency network command received [EmergCmdIn (AV-1182) =2]
PURGE	move the damper to the Purge position, Fan disabled	Emergency network command received [EmergCmdIn (AV-1182)=3]
EMERGENCY COMMAND SHUTDOWN	Shuts down box	Emergency network command received [EmergCmdIn (AV-1182) = 4].
HEAT AND COOL DISABLED	Disables heating and cooling	BACnet object ApplicModeln (AV-1471) = 6 containing AHU operational mode information from BACnet controllers that have the value of Heat, cool and Fan Off.
FAN ONLY	Only fan is enabled	BACnet object ApplicModeln (AV-1471) = 9 containing AHU operational mode information from BACnet controllers that have the value of Fan Only (no heating or cooling)

## Features

Stryker BACnet VAV is a configurable controller offering a comprehensive list of generic and configuration specific features as follows:

- Uses the BACnet® network protocol
- Capable of stand-alone operation, but can also use BACnet® network communications
- Sylk™ bus for use with Sylk-enabled devices
- All wiring connections are made to removable terminal blocks to simplify controller installation and replacement
- Controller housing is UL plenum rated
- Reduces engineering and maintenance time, and ensures proper operation
- Quick configuration saves time for System Integrators
- Provides reliability and simplicity to building owners
- Built-in VAV control applications
- 40 controllers per MS/TP network can be configured
- Field configurable for control, input, and output functions using the NIAGARA FRAMEWORK® software, or Zio wall module
- Significant Event Notification, Periodic Update capability, and Failure Detect (FD) when BACnet object fail to be updated within their configurable time frame
- Configurable Primary air control: Pressure independent or dependent Variable Air Volume
- Configurable reheat output: analog modulating or staged (up to 3 stages)
- Heating PID control loop parameters tuned as a function of reheat type (modulating or staged) and the number of stages
- Configurable peripheral heating including: none, staged, modulating, sequence before or after reheat
- Network initiated:
  - Schedule Bypass
  - Demand Limit Control
  - Emergency commands override airflow control during an event such as a fire
  - Morning Warm-up with configurable Warm-up operating modes
  - Local modulating output
  - Temperature setpoint shift
- Network override of:
  - Local time schedule.
  - Reheat and peripheral heating valves
  - Airflow control.
  - Occupancy mode
  - Effective space temperature setpoint
  - Local inputs
- Network sharing of
  - Occupancy Sensor
  - Space temperature
  - CO<sub>2</sub> Sensor
  - Discharge air temperature
  - Humidity Sensor
  - Wall Module
  - Outdoor air temperature
  - Outdoor air humidity
  - Supply temperature
  - Time Schedule
  - Window sensor
  - Bypass button
- Occupant initiated Schedule Bypass
- Airflow balance options: K factor and or two point using Zio Wall Module as well as Network Tools
- CO<sub>2</sub> coordinated minimum ventilation
- Two freely configurable PID loops that can be used to control additional equipment using free pins available
- Supply & Return Flow tracking
- Lighting control
- Master Wall Module shared with multiple satellite VAV box controls
- Peripheral heat sequenced with reheat
- Control fault tolerance:
  - Pressure dependent fallback control strategy if pressure sensor fails (invalid value)
  - Airflow reverts to minimum flow if space temperature sensor fails (invalid value)
  - Reverts to local space sensor if Wall Module sharing network communications fails

**Table 3: Capabilities of CVB controllers**

CVB Controller Capability	CVB4022AS-VAV1	CVB4024NS-VAV1
<b>Fan</b>		
None	X	X
Series	X	X
Parallel - Temp	X	X
Parallel - Flow	X	X
Parallel - Analog	X	X
Parallel - PWM	X <sup>a</sup>	X <sup>a</sup>
Parallel - Float	X	X
<b>Reheat</b>		
None	X	X

STRYKER VAV CONTROLLER

CVB Controller Capability	CVB4022AS-VAV1	CVB4024NS-VAV1
One Stage Reheat	X	X
Two Stages Reheat	X	X
Three Stages Reheat	X	X
One Stage Periph	X	X
Floating Reheat (Two digital outputs)	X	X
Floating Periph (Two digital outputs)	X	X
PWM Reheat (One digital output)	X <sup>a</sup>	X <sup>a</sup>
PWM Periph (One digital output)	X <sup>a</sup>	X <sup>a</sup>
Analog Reheat	X	X
Analog Peripheral	X	X
<b>Wall Module Type</b>		
TR71/75	X	X
TR2X (Conventional)	X	X

a - Only DO1 & DO2 can be configured as PWM outputs.

## Abbreviations

### A

**AHU:** Air Handling Unit; the central fan system that includes the blower, heating equipment, cooling equipment, ventilation air equipment, and other related equipment.

### B

**Box:** A VAV terminal unit box.

**BACnet®:** BACnet is a communication protocol for Building Automation and Control network.

### C

**CAV:** Constant Air Volume; a Terminal Unit Controller that maintains a fixed airflow through the box.

**CO:** Carbon Monoxide. Occasionally used as a measure of indoor air quality.

**CO<sub>2</sub>:** Carbon Dioxide. Used as a measure of indoor air quality.

**cUL:** Underwriters Laboratories Canada.

### D

**DDF:** Delta Degrees Fahrenheit

**D/X:** Direct Expansion; refers to a type of mechanical cooling where refrigerant is (expanded) to its cold state, within a heat-exchanging coil that is mounted in the air stream supplied to the conditioned space.

### E

**EMI:** Electromagnetic Interference; Electrical noise that can cause problems with communications signals.

**EMS:** Energy Management System; refers to the controllers and algorithms responsible for calculating optimum operational parameters for maximum energy savings in the building.

### F

**Floating Control:** Floating Control utilizes one digital output to pulse the actuator open, and another digital output to pulse it closed.

### I

**IAQ (Indoor Air Quality):** It refers to the quality of the air in the conditioned space, as it relates to occupant health and comfort.

**I/O:** Input/Output, the physical sensors and actuators connected to a controller.

**I \* R:** I times R or current times resistance; refers to Ohm's Law:  $V = I \times R$ .

### K

**K:** Degrees Kelvin

### M

**Module:** Used to allow user-adjusted setpoints to be input into the Controller.

### N

**NEC:** National Electrical Code; the body of standards for safe field wiring practices

**NEMA:** National Electrical Manufacturers Association; the standards developed by an organization of companies for safe field wiring practices

**Node:** A Communications Connection on a network; a Controller is one node on the E-Bus network.

### O

**OEM:** Original Equipment Manufacturer; the company that builds the VAV boxes

### P

**PWM:** Pulse Width Modulated output; allows analog modulating control of equipment using a digital output on the controller

### R

**RTD:** Resistance Temperature Detector; refers to a type of temperature sensor whose resistance output changes according to the temperature change of the sensing element.

### T

**TOD:** Time-Of-Day; the scheduling of Occupied and Unoccupied times of operation.

**TCU:** Terminal Control Unit; industry can refer to VAV box controllers such as the AscBACnetVAV as TCUs.

**TUC:** Terminal Unit Controller; Same as TCU.

### V

**VA:** Volt Amperes; a measure of electrical power output or consumption as applied to an AC device

**VAC:** Voltage alternating current; AC voltage rather than DC voltage

**VAV:** Variable Air Volume; refers to either a type of air distribution system, or VAV Box Controller that controls a single zone in a variable air volume delivery system.

### W

**Wall Module:** The Space Temperature Sensor and other optional controller inputs are contained in the Zio - The TR71/75 LCD wall module.

## APPLICATION STEPS

The application steps serve as planning considerations for engineering Stryker BACnet VAV system. These steps are guidelines for the product I/O options, bus arrangement choices, configuration options, and the Niagara Framework® role in the overall Stryker BACnet VAV system architecture.

### Plan the System

In order to plan the system, software requirements and system hardware need to be analyzed.

- Hardware requirements include DDC controller specifications and control sequence. It is important to ensure that the DDC controller specifications, network communication requirements, and control sequence are in accordance with the Stryker BACnet VAV controller. For verifying hardware requirements, refer to the [Hardware](#) section of this guide.
- Software requirements include various configurable applications, configuration details, and control sequence. For verifying software requirements, refer to the Software section of this guide.

### Hardware Design

When the Stryker BACnet VAV controller specifications are satisfying all the requirements of the given application, the next step is to design the system. Designing the system includes selection of the sensors and actuators as per the system design, design of panel layout, network architecture, wiring diagram, power requirement (sizing transformers), and preparation of Bill of Material. For details on hardware design, refer to the [Hardware](#) section of this guide. While designing network architecture, refer to [Wiring](#) section for wiring details and its limitations.

### Place the order

After completion of the Hardware Design, place the order for purchasing the material mentioned in the Bill of Material.

### List of Accessories

Honeywell Stryker BACnet VAV controller is capable of stand-alone operation and can be ordered as an individual component. However, it supports different configurations depending upon the site-specific requirements. [Table 4](#) shows the list of accessories that are selected to implement these configurations. These accessories are not mandatory however can be selected to perform their associated functions for the site in consideration.

**Table 4: Accessories List**

Accessories	Description
TR7X Wall Module	If VAV wall module type is configured as 'TR71/75', this wall module is required.
TR2X Wall Module	If VAV Wall module type is configured as 'Conventional Wall module', TR21/23 wall modules can be used.
C7041B, C, D, P, R Air Temperature Sensor (indoor)	Honeywell Series 2000 temperature sensors. Types include Duct, immersion, space, averaging.
C7041F Air Temperature Sensor (outdoor)	20K Ω NTC Outdoor Temperature Sensor, Operating range: -40 oF to 158 oF
C7400A Enthalpy Sensor	If Enthalpy Type is configured as 'Differential Enthalpy C7400 MA' or 'Outdoor Enthalpy C7400 MA' this sensor is required for Outdoor and return enthalpy measurement
C7262 CO <sub>2</sub> Sensor Family	Wall Mount CO <sub>2</sub> /Temp Sensor with display, 0/2 – 10 VDC or 0/4 - 20 mA output
H7625, H7635, and H7655 Humidity and Temperature Sensors	Duct and wall mounted humidity sensors.
P7640 Pressure Transducer Family	Universal differential pressure sensors
C7600 Humidity Sensor Family	Used with any controller capable of processing a 4-20 mA or 2-10 Vdc signal.
201052A, B, C Auxiliary Switches (one, two or three switches)	It allows for control of equipment external to the actuator at an adjustable point in the actuator stroke
C7770A Air Temperature Sensor (indoor/plenum)	C7770A Air Temperature Sensor is direct wired temperature sensor that is used to sense discharge or return air in a duct.
C7031G Air Temperature Sensor (outdoor)	The C7031G Air Temperature Sensor is used to sense outdoor air temperature.
7041B2013/U, C7041B2005/U	The C7041B series of electronic temperature sensors can be used for Discharge Air Temperature.



Refer to the "Sensors Product Overview," form 63-9285, for additional accessories.

	<b>Note:</b>
<i>Accessories shown in <a href="#">Table 4</a> vary as per the application requirement.</i>	

## Installation and Wiring

### Pre-requisite:

Refer [Specifications](#) section for the power, input, and output specifications before installing the controller.

- Hardware driven by Triac outputs must have a minimum current draw, when energized, of 25 mA and a maximum current draw of 500 mA.
- Hardware driven by the analog current outputs must have a maximum resistance of 550 Ohms, resulting in a maximum voltage of 11 volts when driven at 20 mA.

If resistance exceeds 550 Ohms, voltages up to 11.5 Vdc are possible at the analog output terminal.

### Installation

The controller must be mounted in a position that allows clearance for wiring, servicing, removal, connection of the BACnet® Bus Jack.

	<b>Note:</b>
<i>Avoid mounting in areas where acid fumes or other deteriorating vapors can attack the metal parts of the controller, or in areas where escaping gas or other explosive vapors are present</i>	

## Configuration and Testing of the VAV Controller

When installation and wiring of the VAV controller is completed and it is powered up, next step is to configure the VAV controller as per the control sequence. For details on configuring VAV controller via WEBStation software tool, refer to VAV Configuration Wizard guide. For details on configuring VAV controller via TR71/75 wall module, refer to the Stryker VAV Zio CVB4024NS-VAV1 and CVB4022AS-VAV1 guide.

## HARDWARE

This section describes hardware details of the VAV controller, ZIO wall module and TR21/23 wall module.

This information will help to design a system and select appropriate components as per requirement. It also provides guidelines and information useful during installation and commissioning of the system.

Main topics covered are:

- Specifications and detailed description of the devices
- Mounting and fitting of the devices
- Power Budget (Transformer sizing)
- Wiring requirements and wiring details

### VAV Controller (CVB4024NS-VAV1 and CVB4022AS-VAV1)

#### Specifications

##### Dimensions

H/W/D: 5.45 x 6.85 x 2.26 in. (13.84 x 17.40 x 5.74 cm)

##### Electrical

**Rated Voltage:** 20 VAC -30 VAC; 50/60 Hz

##### Power Consumption

100 VA for controller and all connected loads

**Controller only Load:** 5 VA maximum, model CVB4024NS-VAV1

##### External Sensors Power Output

20 VDC  $\pm$ 10 % @ 75 mA maximum

##### Environmental

##### Operating & Storage Temperature Ambient Rating

Minimum - 32 °F (0 °C); Maximum 122 °F (50 °C)

**Relative Humidity:** 5 % to 95 % non-condensing

##### Approval Bodies

- UL/cUL (E87741) listed under UL916 (Standard for Open Energy Management Equipment) with plenum rating. CSA (LR95329-3) listed.
- Meets FCC Part 15, Subpart B, Class B (radiated emissions) requirements.
- Meets Canadian standard C108.8 (radiated emissions). Conforms to the following requirements per European Consortium standards:  
EMC Directive: 2004/108/EC

Standards Applied:

- EN 61000-6-1: 2007;
- EN 61000-6-3: 2007; EN 61000-6-3:2007/A1:2011;

Annex H.26

- EN 60730-2-9: 2008
- EN 60730-2-14: 1997 + A1: 2001 + A2: 2008
- RoHS Directive: 2011/65/EC
- BTL B-ASC (BACnet Testing Laboratories, BACnet Application Specific Controller)

#### Velocity Pressure Sensor

**Operating Range:** 0 to 1.5 in. H<sub>2</sub>O (0 to 374 Pa)

#### Series 60 Floating Actuator

**Rotation Stroke:** 95°  $\pm$  3° for CW or CCW opening dampers Torque Rating: 44 lb-in. (5 Nm)

**Run Time for 90° rotation:** 90 seconds at 60 Hz

#### Hardware

##### CPU

Each controller uses a Texas Instruments MSP430 family microprocessor. The processor contains on-chip FLASH program memory, FLASH information memory, and RAM.

##### Memory Capacity

**Flash Memory:** 116 kilobytes with 8 kilobytes available for user program. The controller is able to retain FLASH memory settings for up to ten (10) years.

**RAM:** 8 kilobytes

##### Real Time Clock

**Operating Range:** 24 hour, 365 day, multi-year calendar including day of week and configuration for automatic daylight savings time adjustment to occur at 2:00 a.m. local time on configured start and stop dates.

##### Power Failure Backup:

24 hours at 32 to 100° F (0 to 38° C),

22 hours at 100 to 122° F (38 to 50° C)

**Accuracy:**  $\pm$ 1 minute per month at 77° F (25° C)

#### Inputs and Outputs

CVB4022AS-VAV1 has four universal input (UI) circuits, two analog outputs (AO), and two digital Triac outputs (DO). Two Digital Outputs are reserved for the actuator. CVB4024NS-VAV1 has four universal input (UI) circuits, two analog outputs (AO), and four digital Triac outputs (DO).

### Universal Input (UI) Circuits

Refer to [Table 5](#) for the UI specifications

**Table 5: Universal Input Circuit Specifications**

Input Type	Sensor Type	Operating Range
Room/Zone Discharge Air Outdoor Air Supply Air Temperature	20K Ohm	Room/Zone Discharge Air Outdoor Air Supply Air Temperature
Outdoor Air Temperature	C7031G <sup>a</sup>	-40° to 120°F (-40° to 49°C)
	C7041F <sup>a</sup>	-40° to 250°F (-40° to 121°C)
	PT1000 (IEC751 3850)	-40° F to 199° F (-40° C to 93° C)
TR23 Setpoint Potentiometer	500 Ohm to 10,500 Ohm	-4° DDC to 4° DDC (-8° DDF to 7° DDF) or 50° F to 90° F (10° C to 32° C)
Resistive Input	Generic	100 Ohms to 100K Ohms
Voltage Input	Transducer, Controller	0–10 Vdc
Discrete Input	Dry Contact closure	Open Circuit ≥ 3000Ohms Closed-circuit < 3000Ohms

<sup>a</sup>C7031G and C7041F are recommended for use with these controllers, due to improved resolution and accuracy when compared to the PT1000.

### Analog Output (AO) Circuits

#### Analog current outputs:

Current Output Range: 4.0 to 22.0 mA  
Output Load Resistance: 550 Ohms maximum

#### Analog voltage outputs:

Voltage Output Range: 0 to 11 V  
Output minimum load resistance: 600 Ohms  
Switchover point from current to voltage is approximately 570 Ohms

### Digital Triac Output (DO) Circuits

Voltage Rating: 20 to 30 Vac @ 50-60Hz  
Current Rating: 25 mA to 500 mA continuous, 800 mA (ACrms) for 60 milliseconds

### Status Information

The LED on the front of the controller provides a visual indication of the status of the device. When the controller receives power, the LED appears in one of the following allowable states, as described in [Table 6](#).

**Table 6: LED States**

LED State	Blink Rate	Status or Condition
OFF	not applicable	No power to processor, LED damaged, low voltage to board, or controller damaged.
ON	ON steady; not blinking	Processor and/or controller is not operating.
Very slow blink (continuous)	1 second ON, 1 second OFF	Controller is operating normally.
Slow blink (continuous)	0.5 second ON, 0.5 second OFF	Controller alarm is active, controller in process of download, or controller lost its configuration.
Medium blink (continuous)	0.25 second ON, 0.25 second OFF	Controller firmware is loading.
Fast blink (continuous)	0.10 second ON, 0.10 second OFF	Controller is in manual mode under control of the PC-based software tool.

### Communications

Each controller uses a BACnet MS/TP communications port. The controller's data is presented to other controllers over a twisted-pair MS/TP network, which uses the EIA-485 signaling standard capable of the following baud rates: 9.6, 19.2, 38.4, 76.8 or 115.2 kilobits per second (configured at global controller).

### Sylk™ Bus

Sylk is a two wire, polarity insensitive bus that provides both 18 Vdc power and communications between Sylk-enabled devices. Using Sylk-enabled devices saves I/O on the controller and is faster and cheaper to install since only two wires are needed and the bus is polarity insensitive.

## Mounting

### Mount Actuator onto Damper Shaft (CVB4022AS-VAV1 only)

The CVB4022AS-VAV1 controller includes the direct-coupled actuator with Declutch mechanism, which is shipped hard-wired to the controller. The actuator mounts directly onto the VAV box damper shaft and has up to 44 lb-in. (5 Nm) torque, 90-degree stroke, and 90 second timing at 60 Hz. The actuator is suitable for mounting onto a 3/8 to 1/2 in. (10 to 13 mm) square or round VAV box damper shaft. The minimum VAV box damper shaft length is 1-9/16 in. (40 mm).

The two mechanical end-limit set screws control the amount of rotation from 12° to 95°. These set screws must be securely fastened in place. To ensure tight closing of the damper, the shaft adapter has a total rotation stroke of 95° (Refer to [Figure 3](#)).

	<b>Note:</b>
<p>The actuator is shipped with the mechanical end-limit set screws set to 95 degrees of rotation. Adjust the two set screws closer together to reduce the rotation travel. Each "hash mark" indicator on the bracket represents approximately 6.5° of rotation per side.</p>	
<p>The Declutch button, when pressed, allows you to rotate the universal shaft adapter (Refer to <a href="#">Figure 3</a>).</p>	

	<b>Important:</b>
<p>Determine the damper rotation and opening angle prior to installation. Refer to <a href="#">Figure 4</a> and <a href="#">Figure 5</a> for examples</p>	

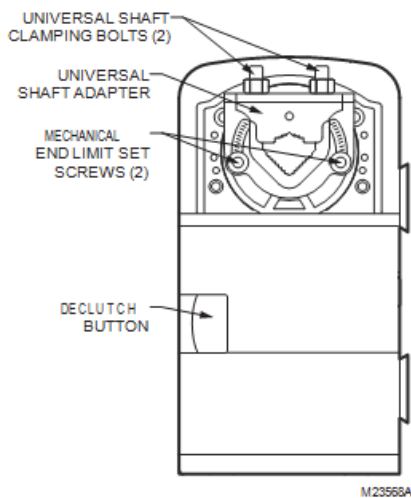

**Figure 3: Series 60 Floating Actuator**

	<b>Important:</b>
<p>Mount actuator flush with damper housing or add a spacer between the actuator mounting surface and damper box housing.</p>	

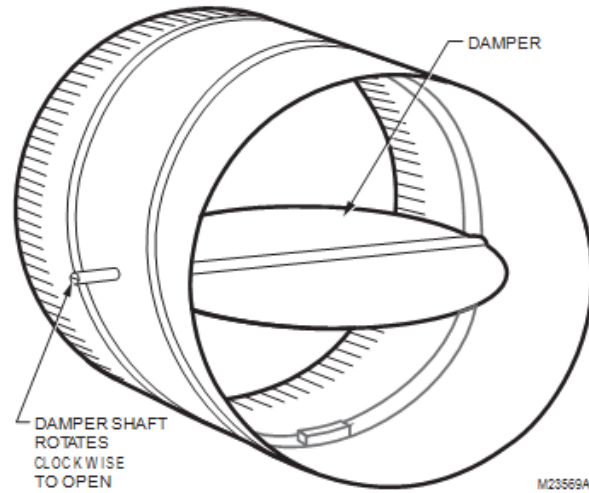

**Figure 4: Damper with 90 degree CW rotation to open**

### Before Mounting Actuator onto Damper Shaft (CVB4022AS-VAV1 only)

Tools required:

- Phillips #2 screwdriver - end-limit set screw adjustment
- 8 mm wrench - centering clamp

Before mounting the actuator onto the VAV box damper shaft, determine the following:

1. Determine the damper shaft diameter. It must be within 3/8 in. to 1/2 in. (10 to 13 mm).
2. Determine the length of the damper shaft. If the length of the VAV box damper shaft is less than 1-9/16 in. (40 mm), the actuator cannot be used.
3. Determine the direction the damper shaft rotates to open the damper (CW or CCW) (see [Figure 5](#)). Typically, there is an etched line on the end of the damper shaft that indicates the position of the damper. In [Figure 4](#), the indicator shows the damper open in a CW direction.
4. Determine the damper full opening angle (45, 60, or 90 degrees). In [Figure 4](#), the damper is open to its full open position of 90 degrees.

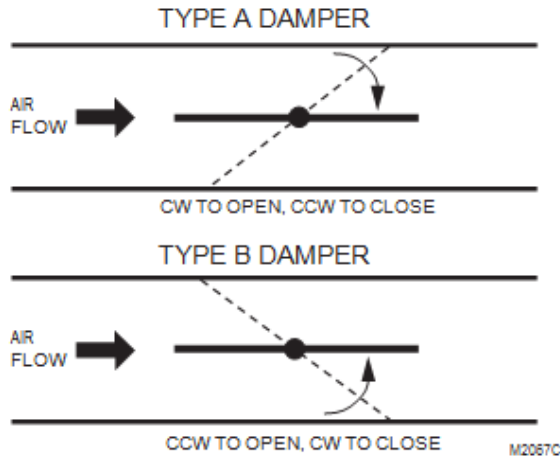

**Figure 5: Determining the rotation direction (CW or CCW) for damper opening**

**Mounting Actuator onto Damper Shaft (CVB4022AS-VAV1 only)**

The unit is shipped with the actuator set to rotate open in the clockwise (CW) direction to a full 95 degrees. The extra 5 degrees ensures a full opening range for a 90 degree damper. The installation procedure varies depending on the damper opening direction and angle:

1. If the damper rotates clockwise (CW) to open, and the angle of the damper open-to-closed is 90 degrees:
  - a. Manually open the damper fully (rotate clockwise)
  - b. Using the Declutch button, rotate the universal shaft adapter fully clockwise
  - c. Mount the actuator to the VAV damper box and shaft
  - d. Tighten the two bolts on the centering clamp (8 mm wrench; 70.8-88.5 lb-in. [8-10 Nm] torque). When the actuator closes, the damper rotates CCW 90 degrees to fully close
2. If the damper rotates clockwise (CW) to open, and the angle of the damper open-to-closed is 45 or 60 degrees:
  - a. Manually open the damper fully (rotate clockwise)
  - b. The actuator is shipped with the mechanical end-limits set at 95 degrees. Adjust the two mechanical end-limit set screws to provide the desired amount of rotation. Adjust the two set screws closer together to reduce the rotation travel
  - c. Tighten the two mechanical end-limit screws (Phillips #2 screwdriver; (26.5-31 lb-in. [3.0-3.5 Nm] torque)
  - d. Using the Declutch button, rotate the universal shaft adapter fully clockwise

- e. Mount the actuator to the VAV damper box and shaft
  - f. Tighten the two bolts on the centering clamp (8 mm wrench; 70.8-88.5 lb-in. [8-10 Nm] torque)
  - g. When the actuator closes, the damper rotates CCW either 45 or 60 degrees to fully close
3. If the damper rotates counterclockwise (CCW) to open, and the angle of the damper open-to-closed is 90 degrees:
    - a. Manually open the damper fully (rotate counterclockwise)
    - b. Using the Declutch button, rotate the universal shaft adapter fully counterclockwise
    - c. Mount the actuator to the damper box and shaft.
    - d. Tighten the two bolts on the centering clamp (8 mm wrench; 70.8-88.5 lb-in. [8-10 Nm] torque). When the actuator closes, the damper rotates CW 90 degrees to fully close
  4. If the damper rotates counterclockwise (CCW) to open, and the angle of the damper open-to-closed is 45 or 60 degrees:
    - a. Manually open the damper fully (rotate counterclockwise)
    - b. The actuator is shipped with the mechanical end-limits set at 95 degrees. Adjust the two mechanical end-limit set screws to provide the desired amount of rotation. Adjust the two set screws closer together to reduce the rotation travel
    - c. Tighten the two mechanical end-limit screws (Phillips #2 screwdriver; (26.5-31 lb-in. [3.0-3.5 Nm] torque)
    - d. Using the Declutch button, rotate the universal shaft adapter fully counter-clockwise
    - e. Mount the actuator to the VAV damper box and shaft
    - f. Tighten the two bolts on the centering clamp (8 mm wrench; 70.8-88.5 lb-in. [8-10 Nm] torque)
    - g. When the actuator closes, the damper rotates CW either 45 or 60 degrees to fully close

**Mount Controller**

	<b>Note:</b>
<p><i>The controller may be wired before mounting to a panel or DIN rail. Terminal blocks are used to make all wiring connections to the controller. Attach all wiring to the appropriate terminal blocks (See "Wiring").</i></p>	

### Panel Mounting

The controller enclosure is constructed of a plastic base plate and a plastic factory-snap-on cover.

	<b>Note:</b>
<p>The controller is designed so that the cover does not need to be removed from the base plate for either mounting or wiring. The controller mounts using four screws inserted through the corners of the base plate. Fasten securely with four No. 6 or No. 8 machine or sheet metal screws.</p>	

The controller can be mounted in any orientation. Ventilation openings are designed into the cover to allow proper heat dissipation, regardless of the mounting orientation.

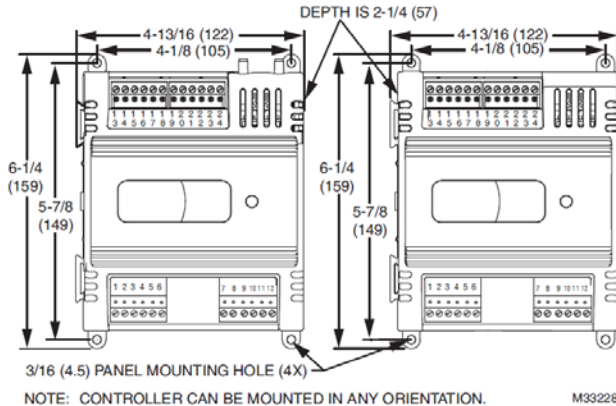

**Figure 6: Panel mounting - controller dimensions in inches (mm) for CVB4024NS-VAV1 only**

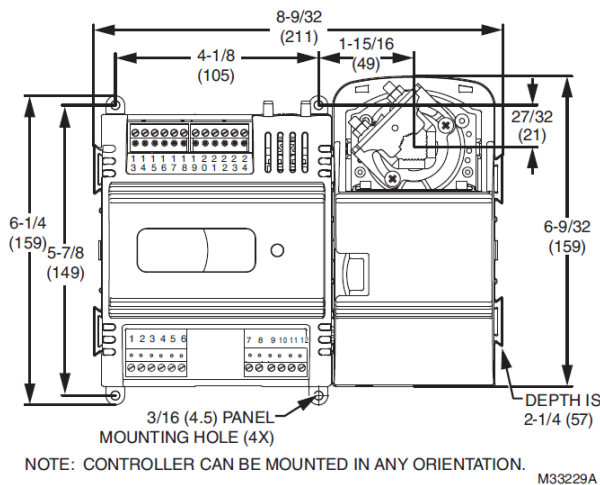
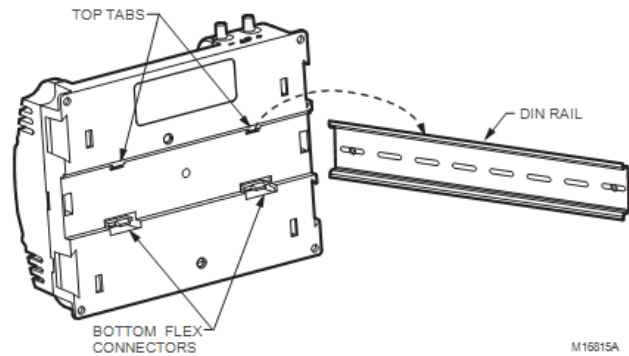

**Figure 7: Mounting - controller and actuator dimensions in inches (mm) for CVB4022AS-VAV1 only**

### DIN Rail Mounting (CVB4024NS-VAV1 only)

To mount the CVB4024NS-VAV1 controller on a DIN rail [standard EN50022; 1-3/8 in. x 9/32 in. (7.5 mm x35 mm)], refer to [Figure 11](#) and perform the following steps:

1. Holding the controller with its top tilted in towards the DIN rail, hook the two top tabs on the back of the controller onto the top of the DIN rail.
2. Push down and in to snap the two bottom flex connectors of the controller onto the DIN rail.



**Figure 8: Controller DIN rail mounting (CVB4024NS-VAV1)**

	<b>Important:</b>
<p>To remove the controller from the DIN rail, perform the following:</p> <ol style="list-style-type: none"> <li>1. Push straight up from the bottom to release the top tabs.</li> <li>2. Rotate the top of the controller out towards you, pull the controller down, and away from the DIN rail to release the bottom flex connectors.</li> </ol>	

## Piping

### Airflow Pickup

Connect the airflow pickup to the two restrictor ports on the controller (see [Figure 9](#)).

	<b>Notes:</b>
<ol style="list-style-type: none"> <li>1. Use 1/4 inch (6 mm) outside diameter, with a 0.040 in. (1 mm) wall thickness, plenum-rated 1219 FR (94V-2) tubing.</li> <li>2. Always use a fresh cut on the end of the tubing that connects to the airflow pickups and the restrictor ports on the controller.</li> </ol>	

Connect the high pressure or upstream tube to the plastic restrictor port labeled (+), and the low pressure or downstream tube to the restrictor port labeled (-). When twin tubing is used from the pickup, split the pickup tubing a short length to accommodate the connections.

	<b>Note:</b>
<p>If controllers are mounted in unusually dusty or dirty environments, an inline, 5-micron disposable air filter (use 5-micron filters compatible with pneumatic controls) is recommended for the high pressure line (marked as +) connected to the airflow pickup.</p> <p>The tubing from the airflow pickup to the controller should not exceed three feet (0.914 m). Any length greater than this will degrade the flow sensing accuracy. Use caution when removing tubing from a connector.</p>	

Always pull straight away from the connector or use diagonal cutters to cut the edge of the tubing attached to the connector. Never remove by pulling at an angle.

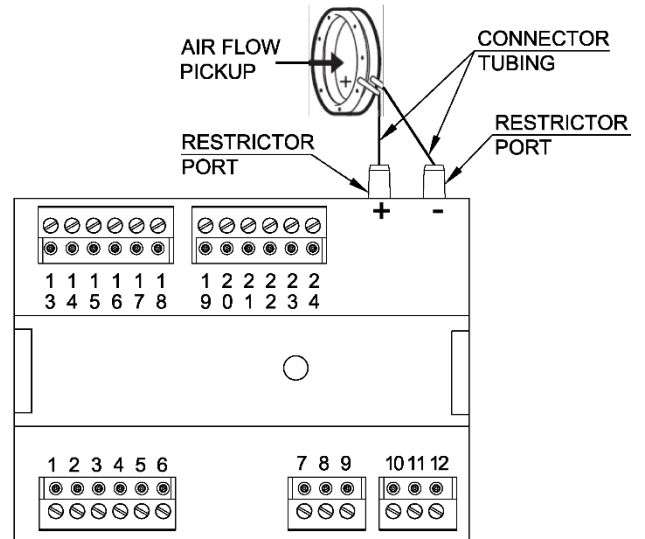

**Figure 9: Airflow pickup connections**

## Power

Before wiring the controller, determine the input and output device requirements for each controller used in the system. Select input and output devices compatible with the controller and the application. Consider the operating range, wiring requirements, and the environment conditions when selecting input/output devices. When selecting actuators for modulating applications, consider using floating control. In direct digital control applications, floating actuators will generally provide control action equal to or better than an analog input actuator for lower cost.

Determine the location of controllers, sensors, actuators and other input/output devices and create wiring diagrams. Refer to [Figure 18](#) and [Figure 19](#) beginning for illustrations of typical controller wiring for various configurations.

The application engineer must review the control job requirements. This includes the sequences of operation for the controller, and for the system as a whole. Usually, there are variables that must be passed between the controllers that are required for optimum system wide operation. Typical examples are the TOD, Occ/Unocc signal, the outdoor air temperature, the demand limit control signal, and the smoke control mode signal. It is important to understand these interrelationships early in the job engineering process, to ensure proper implementation when configuring the controllers.

### Power Budget

A power budget must be calculated for each device to determine the required transformer size for proper operation. A power budget is simply the summing of the maximum power draw ratings (in VA) of all the devices to be controlled. This includes the controller itself and any devices powered from the controller, such as equipment actuators (ML6161 or other motors) and various contactors and transducers.

	<b>Important:</b>
<ul style="list-style-type: none"> <li>If a controller is used on Heating and Cooling Equipment (UL 1995, U.S. only) and transformer primary power is more than 150 volts, connect the transformer secondary common to earth ground</li> <li>When multiple controllers operate from a single transformer, connect the same side of the transformer secondary to the same power input terminal in each device. The earth ground terminal (terminal 3) must be connected to a verified earth ground for each controller in the group.</li> </ul>	

### Power Budget Calculation Example (VA)

[Table 7](#) is an example of a power budget calculation for a typical CVB controller.

The system example above requires 30.7 VA of peak power. Therefore, a 100 VA AT92A transformer could be used to power one controller of this type. Because the total peak power is less than 50 VA. Refer to [Table 8](#) for VA ratings of various devices

**Table 7: Power Budget Calculation Example**

Device	VA Information	Obtained From
CVB4022AS-VAV1 controller (include Series 60 Floating Damper Actuator)	9.0	Refer to "Specifications"
R8242A Contactor fan rating	21.0	TRADELINE® Catalog inrush rating
D/X Stages	0.0	For example, assume cooling stage outputs are wired into a compressor control circuit and have no impact on the budget.
M6410A Steam Heating Coil Valve	0.7	TRADELINE® Catalog, 0.32A 24 Vac
<b>TOTAL</b>	<b>30.7</b>	



**Table 8: VA Ratings for Transformer Sizing**

Device	Description	VA
CVB4022AS-VAV1 controllers and Series 60 Floating Damper Actuator	Controller and Actuator	9.0
CVB4024NS-VAV1	Controller	5.0
ML684	Versa drive Valve Actuator	12.0
ML6161	Damper Actuator, 35 lb-in.	2.2
ML6185	Damper Actuator SR 50 lb-in	12.0
ML6464	Damper Actuator, 66 lb-in.	3.0
ML6474	Damper Actuator, 132 lb-in.	3.0
R6410A	Valve Actuator	0.7
R8242A	Contactora	21.0

For contactors and similar devices, the in-rush power ratings should be used as the worst case values when performing power budget calculations. In addition, the application engineer must consider the possible combinations of simultaneously energized outputs and calculate the VA ratings accordingly. The worst case, which uses the largest possible VA load, should be determined when sizing the transformer. Each controller requires 24 Vac power from an energy-limited Class II power source. To conform to Class II restrictions (U.S. only), transformers must not be larger than 100 VA. A single transformer can power more than one controller.

**Line Loss**

Controllers must receive a minimum supply voltage of 20 Vac. If long power or output wire runs are required, a voltage drop due to Ohms Law (I x R) line-loss must be considered. This line-loss can result in a significant increase in total power required and thereby affect transformer sizing. The following example is an I x R line-loss calculation for a 200 ft. (61m) run from the transformer to a controller drawing 37 VA and using two 18 AWG (1.0 sq. mm) wires.

The formula is:

$$Loss = [length\ of\ round-trip\ wire\ run\ (ft.)] \times [resistance\ in\ wire\ (ohms\ per\ ft.)] \times [current\ in\ wire\ (amperes)]$$

From specification data:

18 AWG twisted pair wire has a resistance of 6.52 ohms per 1000 feet.

$$Loss = [(400\ ft.) \times (6.52/1000\ ohms\ per\ ft.)] \times [(37\ VA) / (24V)] = 4.02\ volts$$

This means that four volts are going to be lost between the transformer and the controller. To assure the controller receives at least 20 volts, the transformer must output more than 24 volts. Because all transformer output voltage levels depend on the size of the connected load, a larger transformer outputs a higher voltage than a smaller one for a given load.

Figure 10 shows this voltage load dependence.

In the preceding I x R loss example, even though the controller load is only 37 VA, a standard 40 VA transformer is not sufficient due to the line-loss. Looking at Figure 10, a 40 VA transformer is just under 100 percent loaded (for the 37 VA controller) and has a secondary voltage of 22.9 volts. (Use the lower edge of the shaded zone in Figure 10 that represents the worst case conditions.) When the I x R loss of four volts is subtracted, only 18.9 volts reaches the controller. This is not enough voltage for proper operation.

In this situation, the engineer has three alternatives:

1. Use a larger transformer. For example, if an 80 VA model is used, an output of 24.4 volts, minus the four-volt line-loss, supplies 20.4V to the controller (Refer to Figure 10).

Although acceptable, the four-volt line-loss in this example is higher than recommended.

	<b>Important:</b>
<p><i>No installation should be designed where the line-loss is greater than two volts. This allows for nominal operation if the primary voltage drops to 102 Vac (120 Vac minus 15 percent).</i></p>	

2. Use heavier gauge wire for the power run. 14 AWG (2.0 sq. mm) wire has a resistance of 2.57 ohms per 1,000 ft. Using the preceding formula results in a line-loss of only 1.58 volts (compared with 4.02 volts). This would allow a 40 VA transformer to be used. 14 AWG (2.0 sq. mm) wire is the recommended wire size for 24 Vac wiring.
3. Locate the transformer closer to the controller. This reduces the length of the wire run, and the line-loss. The issue of line-loss is also important in the case of the output wiring connected to the Triac digital outputs. The same formula and method are used. Keep all power and output wire runs as short as practical. When necessary, use heavier gauge wire, a bigger transformer, or install the transformer closer to the controller.

To meet the National Electrical Manufacturers Association (NEMA) standards, a transformer must stay within the NEMA limits. The chart in Figure 10 shows the required limits at various loads. With 100 percent load,

the transformer secondary must supply between 23 and 25 volts to meet the NEMA standard. When a purchased transformer meets the NEMA standard DC20-1986, the transformer voltage regulating ability can be considered reliable. Compliance with the NEMA standard is voluntary.

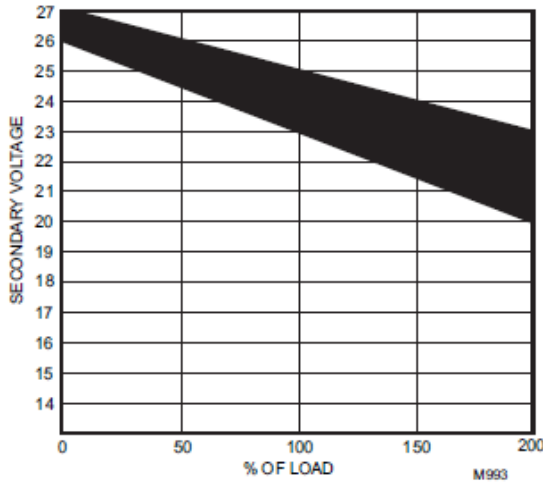

**Figure 10: NEMA Class 2 transformer voltage output limits**

The Honeywell transformers listed in [Table 9](#) meet the NEMA standard DC20-1986.

**Table 9: Honeywell Transformers that meet NEMA Standard DC20-1986**

Transformer Type	VA Rating
AT40A	40
AT72D	40
AT87A	50
AK3310 Assembly	100

**Note:**  
The AT88A and AT92A transformers do not meet the voluntary NEMA standard DC20-1986.

## Wiring

All wiring must comply with applicable electrical codes and ordinances, or as specified on installation wiring diagrams. Controller wiring is terminated to the screw terminal blocks located on the top and the bottom of the device.

	<b>Caution:</b>
<p><i>Electrical Shock Hazard causes severe injury, death or property damage.</i></p> <p><i>Disconnect power supply before beginning wiring or making wiring connections, to prevent electrical shock or equipment damage</i></p>	

**Notes:**

1. Use 1/4 inch (6 mm) outside diameter, with a 0.040 in. (1 mm) wall thickness, plenum-rated 1219 FR (94V-2) tubing.
2. Always use a fresh cut on the end of the tubing that connects to the airflow pickups and the restrictor ports on the controller.

**Notes:**

1. For multiple controllers operating from a single transformer, the same side of the transformer secondary must be connected to the same power input terminal in each controller. Controller configurations will not necessarily be limited to three devices, but the total power draw, including accessories, cannot exceed 100 VA when powered by the same transformer (U.S. only). For power and wiring recommendations. The earth ground terminal (terminal 3) must be connected to a verified earth ground for each controller in the group.
2. All loads on the controller must be powered by the same transformer that powers the controller itself. A controller can use separate transformers for controller power and output power.
3. Keep the earth ground connection (terminal 3) wire run as short as possible.
4. Do not connect the universal input COM terminals, analog output COM terminals or the digital input/output COM terminals to earth ground. The 24 Vac power from an energy limited Class II power source must be provided to the controller. To conform to Class II restrictions (U.S. only), the transformer must not be larger than 100 VA. [Figure 11](#) depicts a single controller using one transformer.

	<b>Important:</b>
<p><i>Power must be off prior to connecting to or removing connections from the 24 Vac power (24 Vac/24 Vac COM), earth ground (EGND), and 20 Vdc power (20 Vdc) terminals.</i></p>	

**Important:**

Use the heaviest gauge wire available, up to 14 AWG (2.0 sq. mm), with a minimum of 18 AWG (1.0 sq. mm), for all power and earth ground wiring. Screw-type terminal blocks are designed to accept up to one 14 AWG (2.0 sq. mm) conductor or up to two 18 AWG (1.0 sq. mm) conductors. More than two wires that are 18 AWG (2.0 sq. mm) can be connected with a wire nut. Include a pigtail with this wire group and attach the pigtail to the terminal block.

**Important:**

If the controller is used on Heating and Cooling Equipment (UL 1995, U.S. only) and the transformer primary power is more than 150 volts, connect terminal 2, (the 24 Vac common [24 VAC COM] terminal) to earth ground (Refer to [Figure 12](#)). For these applications, each transformer can power only one controller.

**Notes:**

1. Unswitched 24 Vac power wiring can be run in the same conduit as the BACnet® cable.
2. Maintain at least a 3 in. (7.6 cm) separation between Triac outputs and BACnet® wiring throughout the installation.

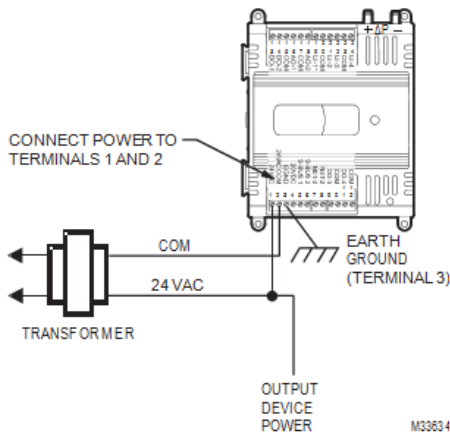

**Figure 11: Power Wiring details for one Controller**

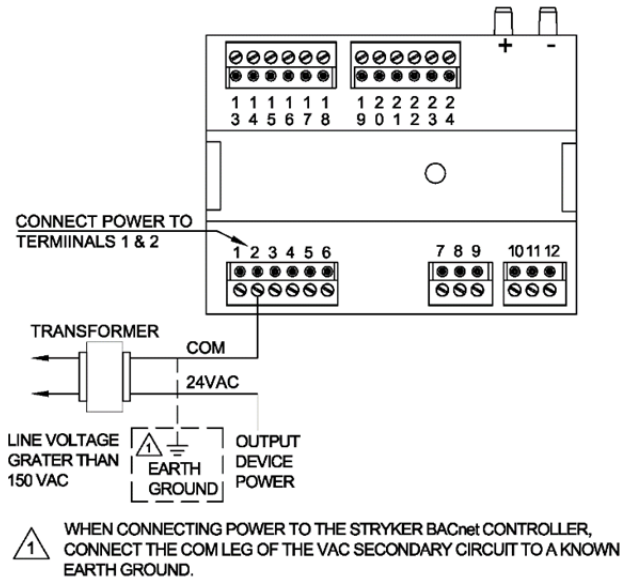

**Figure 12: Transformer power wiring details for one controller used in UL 1995 equipment (U.S. only)**

More than one controller can be powered by a single transformer. [Figure 15](#) shows power wiring details for multiple controllers.

**Notes:**

Controller configurations are not necessarily limited to three devices, but the total power draw, including accessories, cannot exceed 100 VA when powered by the same transformer (U.S. only). For power wiring recommendations, refer to "Wiring".

**Power Wiring**

**Guidelines for Power Wiring**

For multiple controllers operating from a single transformer, the same side of the transformer secondary must be connected to the same power input terminal in each device. The earth ground terminal must be connected to a verified earth ground for each controller in the group (Refer to [Figure 15](#)). Controller configurations are not necessarily limited to two devices, but the total power draw, including accessories, cannot exceed 100 VA when powered by the same transformer (U.S. only).

- Refer to [Figure 8](#) for controller power wiring used in UL 1995 equipment (U.S. only).
- Many controllers require all loads to be powered by the same transformer that powers the controller.
- Keep the earth ground connection wire run as short as possible (Refer to [Figure 13](#) and [Figure 15](#)).
- Do not connect earth ground to the controller's digital or analog ground terminals (Refer to [Figure 13](#) and [Figure 15](#)).
- Unswitched 24 Vac power wiring can be run in the same conduit as the BACnet® cable.

	<b>Important:</b>
<p>Power must be off prior to connecting to or removing connections from the 24 Vac power (24 Vac/24 Vac COM), earth ground (EGND), and 20 Vdc power (20 Vdc) terminals.</p> <p>Use the heaviest gauge wire available, up to 14 AWG (2.0 sq. mm), with a minimum of 18 AWG (1.0 sq. mm), for all power and earth ground wiring. Screw-type terminal blocks are designed to accept up to one 14 AWG (2.0 sq. mm) conductor or up to two 18 AWG (1.0 sq. mm) conductors. More than two wires that are 18 AWG (2.0 sq. mm) can be connected with a wire nut. Include a pigtail with this wire group and attach the pigtail to the terminal block.</p>	

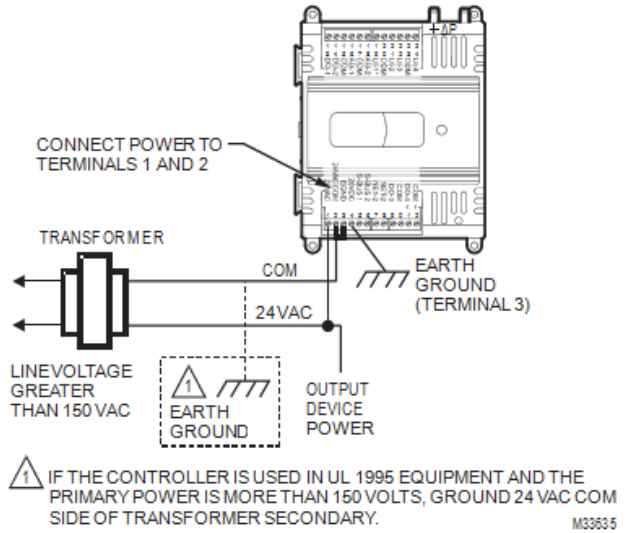

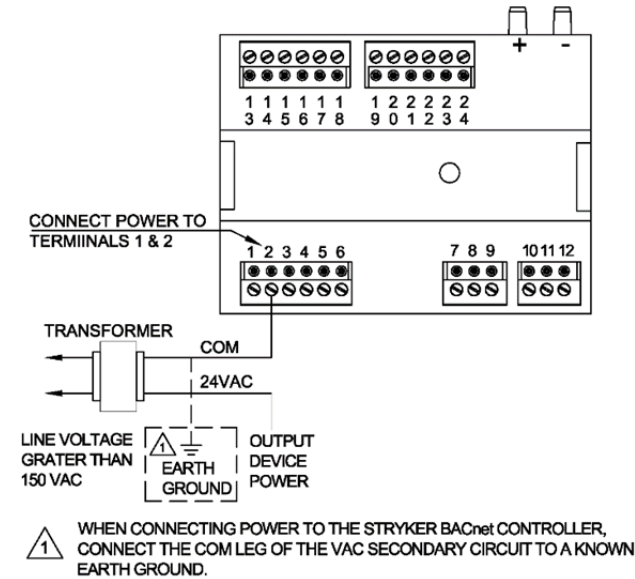

**Figure 14: Transformer power wiring details for one controller used in UL 1995 equipment (U.S. only)**

More than one controller can be powered by a single transformer. [Figure 15](#) shows power wiring details for multiple controllers.



**Figure 13: Power Wiring details for one Controller per Transformer**

	<b>Note:</b>
<p>Controller configurations are not necessarily limited to three devices, but the total power draw, including accessories, cannot exceed 100 VA when powered by the same transformer (U.S. only). For power wiring recommendations, refer to "Power".</p>	

	<b>Important:</b>
<p>If the controller is used on Heating and Cooling Equipment (UL 1995, U.S. only) and the transformer primary power is more than 150 volts, connect terminal 2, (the 24 Vac common [24 VAC COM] terminal) to earth ground (Refer to <a href="#">Figure 14</a>). For these applications, only one controller can be powered by each transformer.</p>	

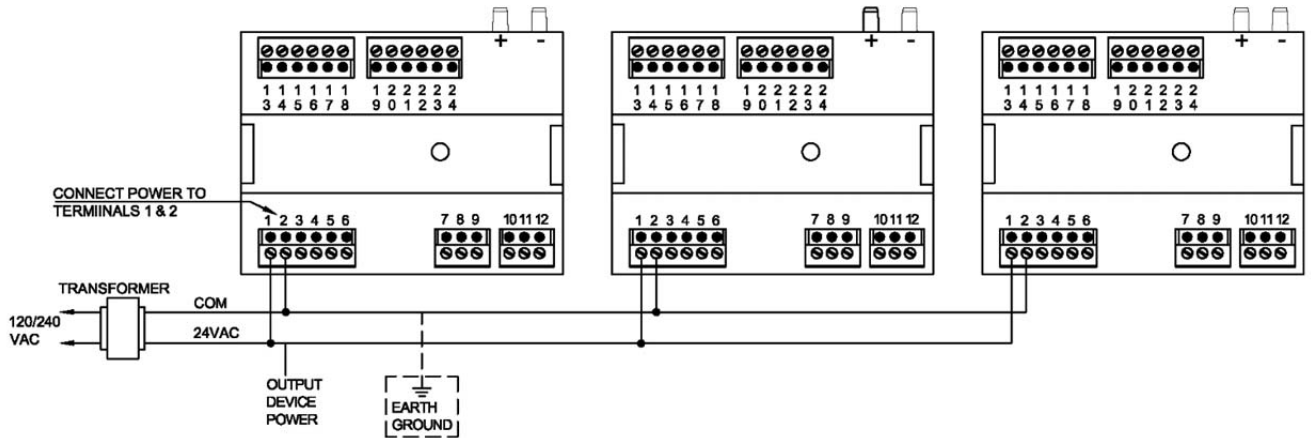

Figure 15: Power Wiring details for two or more Controllers per Transformer

**Communication Wiring**

Each controller uses a BACnet MS/TP communications port. The controllers' data is presented to other controllers over a twisted-pair MS/TP network. The maximum BACnet MS/TP network Bus segment length is 4,000 ft (1,219 m). The theoretical limit for each BACnet MS/TP network Bus segment is 40 controllers. Honeywell provided cable types for BACnet MS/TP Bus communications wiring are Level IV 22 AWG (0.34 sq mm) plenum or non-plenum rated unshielded, twisted pair, stranded conductor wire.

The Honeywell tested and recommended MS/TP cable is Honeywell Cable 3322 (18 AWG, 1-Pair, Shielded, Plenum cable), alternatively Honeywell Cable 3251 (22 AWG, 1-Pair, Shielded, Plenum cable) is available and meets the BACnet Standard requirements. For more information, refer to [www.honeywellcable.com](http://www.honeywellcable.com).

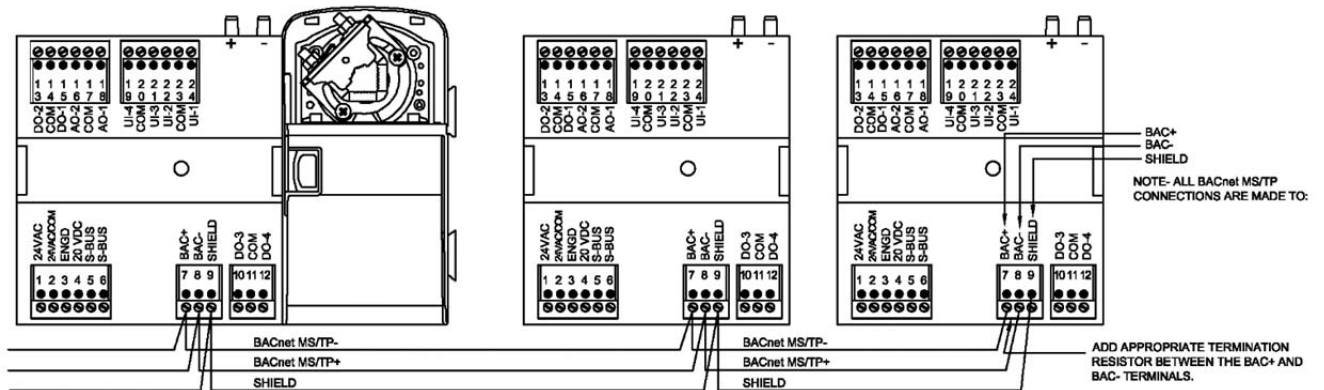

Figure 16: Termination Modules

Notes on communications wiring:

- All field wiring must conform to local codes and ordinances (or as specified on installation drawings).
- Do not bundle device output wires with sensor, digital input or communications BACnet® wires.
- Do not use different wire types or gauges on the same BACnet MS/TP Bus segment. The step change in line impedance characteristics causes unpredictable reflections on the BACnet MS/TP bus.
- In noisy (high EMI) environments, avoid wire runs parallel to noisy power cables, motor control centers, or lines containing lighting dimmer switches. Keep at least 3 in. (76 mm) of separation between noisy lines and the BACnet MS/TP bus cable

The theoretical limit for each BACnet MS/TP Bus segment is 40 controllers.

- Make sure that neither of the BACnet terminals are grounded.

Wiring Method

	<b>Note:</b>
<p>When attaching two or more wires to the same terminal, other than 14 AWG (2.0 sq. mm), be sure to twist them together. Deviation from this rule can result in improper electrical contact (Refer to <a href="#">Figure 17</a>).</p> <p>Each terminal can accommodate the following gauges of wire:</p> <p>Single wire: from 22 AWG to 14 AWG solid or stranded</p> <p>Multiple wires: up to two 18 AWG stranded, with 1/4 watt wire-wound resistor</p>	

Prepare wiring for the terminal blocks, as follows:

1. Strip 1/2 in. (13 mm) insulation from the conductor.
2. Cut a single wire to 3/16 in. (5 mm). Insert the wire in the required terminal location and tighten the screw.
3. If two or more wires are being inserted into one terminal location, twist the wires together a minimum of three turns before inserting them Refer to [Figure 17](#).
4. Cut the twisted end of the wires to 3/16 in. (5 mm) before inserting them into the terminal and tightening the screw.
5. Pull on each wire in all terminals to check for good mechanical connection.

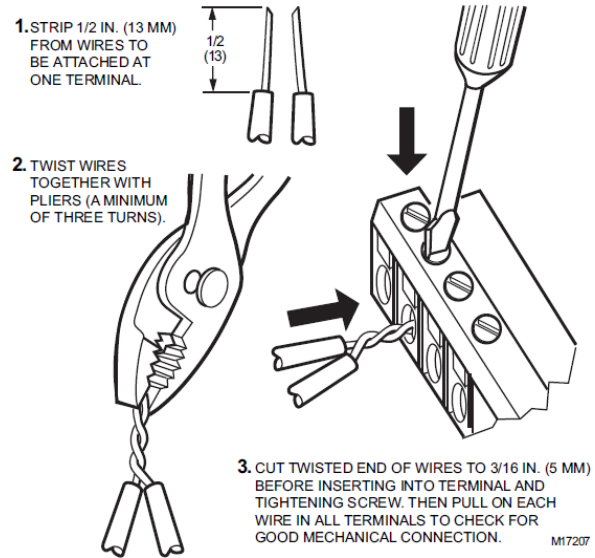

**Figure 17: Attaching two or more wires at terminal blocks**

Wiring Details

Each controller is shipped with the digital outputs, which switch the 24 Vac to the load (High Side). The two analog outputs (AO) are used to control modulating heating, cooling and economizer equipment. Any AO may be used as a digital output, as follows:

- False (0 %) produces 0 VDC, (0 mA)
- True (100 %) produces the maximum 11 VDC (22 mA)

The wiring connection terminals described in [Table 10](#).

**Table 10: Description of Wiring Terminal Connections**

Terminal	Label	Connection
INPUT POWER & GROUND		
1	24 Vac	24 Vac Power
2	24 Vac COM	24 Vac Power
3	EGND	Earth Ground
4	20Vdc	20 Vdc Power
5	SBUS 1	Sylk
6	SBUS 2	Sylk
NETWORK CONNECTIONS		
7	BAC +	BACnet® communications
8	BAC -	BACnet®

Terminal	Label	Connection
		communications
9	SHLD	Shield wire
DIGITAL OUTPUTS <sup>a</sup>		
10	DO-3	Digital Output
11	COM	Common
12	DO-4	Digital Output
13	DO-2	Digital Output
14	COM	Common
15	DO-1	Digital Output
ANALOG OUTPUTS <sup>b</sup>		
16	AO-2	Analog Output
17	COM	Common
18	AO-1	Analog Output
UNIVERSAL INPUTS		
19	UI-4	Universal Input
20	COM	Common
21	UI-3	Universal Input
22	UI-2	Universal Input
23	COM	Common
24	UI-1	Universal Input

<sup>a</sup> For the CVB4022AS-VAV1 controller ONLY, terminals 10-12 (DO-3, COM, & DO-4) are not present. The actuator is internally hard wired to these terminals.

<sup>b</sup> Analog outputs may be configured as digital outputs and operate as follows:

- False (0%) produces 0 Vdc, (0 mA)
- True (100%) produces the maximum 11 Vdc (22 mA)

	<b>Important:</b>
<p><i>If the controller is not connected to a good earth ground, the controllers' internal transient protection circuitry is compromised and the function of protecting the controller from noise and power line spikes cannot be fulfilled. This could result in a damaged circuit board and require replacement of the controller.</i></p>	

### Setting the MS/TP MAC address

The MS/TP MAC address for each device must be set to a unique value in the range of 0-127 on an MS/TP network segment (address 0, 1, 2, & 3 should be avoided as they are commonly used for the router, diagnostic tools, and as spare addresses). DIP switches on the Stryker BACnet controller are used to set the controller's MAC address.

To set the MS/TP MAC address of a Stryker BACnet controller:

1. Find an unused MAC address on the MS/TP network to which the Stryker BACnet controller connects.
2. Locate the DIP switch bank on the Stryker BACnet for addressing. This is labeled MAC Address
3. With the Stryker BACnet Controller powered down, set the DIP switches for the MAC Address you want. Add the value of DIP switches set to ON to determine the MAC address. Example, if only DIP switches 1, 3, 5, and 7 are enabled the MAC address would be 85 (1 + 4 + 16 + 64 = 85).

**Table 11: DIP Switch Values for MS/TP MAC Address**

DIP	7	6	5	4	3	2	1
VALUE	64	32	16	8	4	2	1

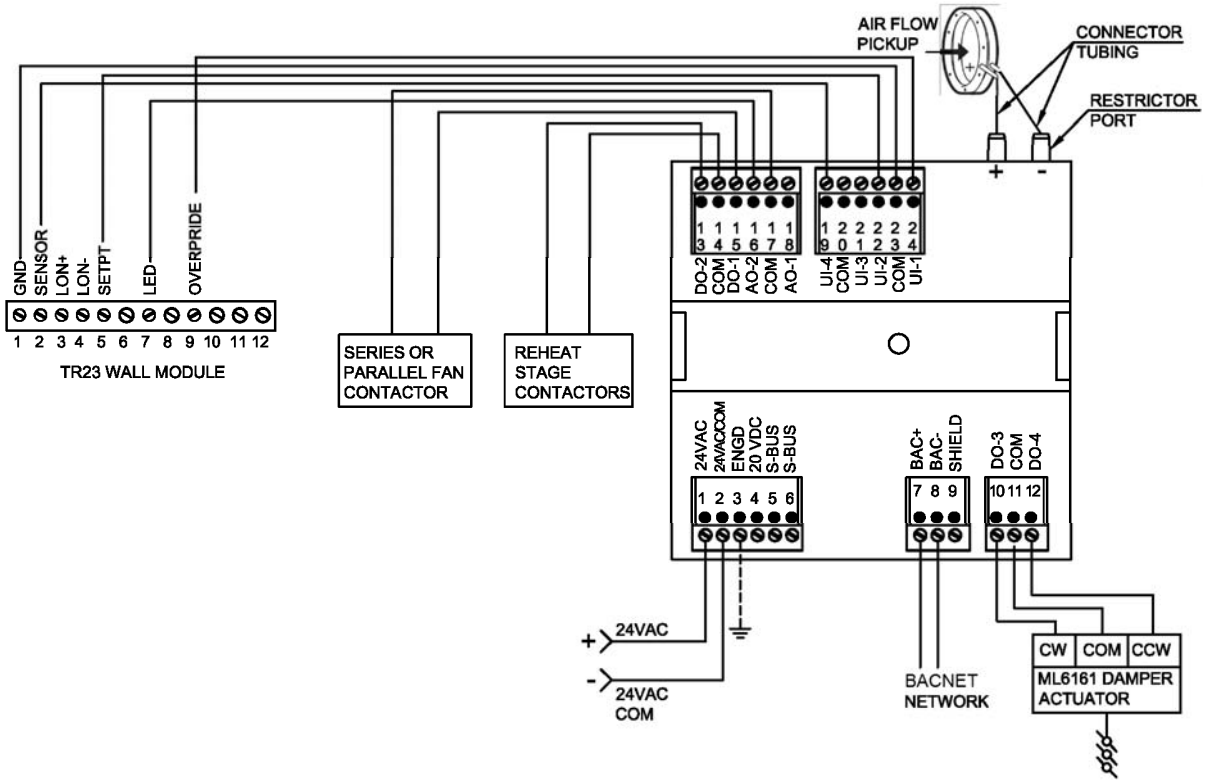

Figure 18: Controller wiring diagram for typical VAV application, using the TR23 wall module

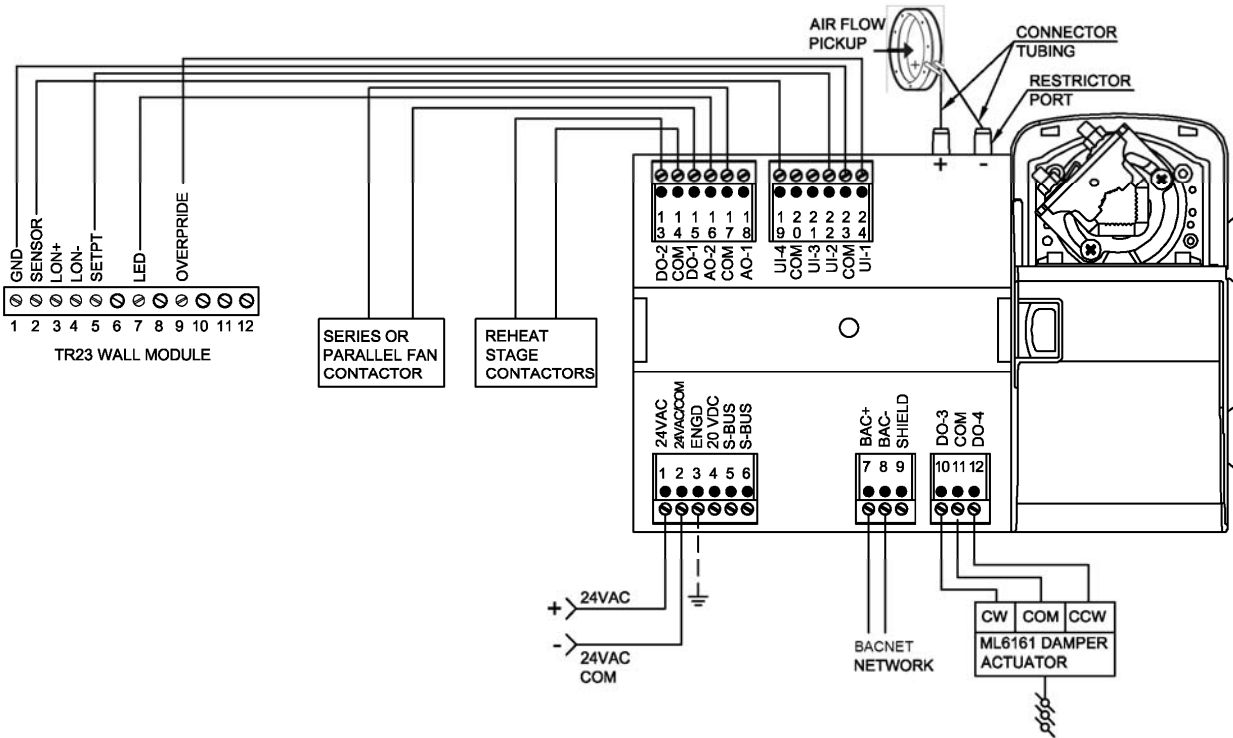

Figure 19: Controller wiring diagram for typical VAV application with staged reheat



## Checkout

### Step 1: Check Installation and Wiring

Inspect all wiring connections at the controller terminals, and verify compliance with installation wiring diagrams. If any wiring changes are required, first be sure to remove power from the controller before starting work. Pay particular attention to:

- 24 Vac power connections. Verify that multiple controllers being powered by the same transformer are wired with the transformer secondary connected to the same input terminal numbers on each controller. Use a meter to measure 24 Vac at the appropriate terminals. Controller configurations are not necessarily limited to three devices, but the total power draw, including accessories, cannot exceed 100 VA when powered by the same transformer (U.S. only).
- Be sure that each controller has terminal 3 wired to a verified earth ground, using a wire run as short as possible with the heaviest gauge wire available, up to 14 AWG (2.0 sq. mm) with a minimum of 18 AWG (1.0 sq. mm) for each controller in the group.
- Check that the MS/TP network terminals are connected properly on each controller. BACnet MS/TP is polarity sensitive; communication will be lost for the entire segment even one controller is connected improperly.
- Verify that Triac wiring of the digital outputs to external devices uses the proper load power and 24 Vac common terminal (digital output common terminals) for High-Side switching.

	<b>Note:</b>
<p><i>All wiring must comply with applicable electrical codes and ordinances or as specified on installation wiring diagrams. For guidelines for wiring run lengths and power budget, see "Power".</i></p>	

### Verify Termination Module Placement (Multiple controllers only)

The installation wiring diagrams should indicate the locations for placement of the termination module(s). Correct placement of the termination module(s) is required for proper BACnet® Bus communications.

### Step 2: Startup

#### Set the MS/TP Mac Address

The MS/TP MAC address DIP switches are used to set the unit's MAC address. Each Stryker BACnet on an MS/TP network must have a unique MAC address in the range of 0-127 (address 0 should be avoided as it is the Honeywell factory default MAC address for all MS/TP devices).

#### Controller Status LED

The LED on the front of the controller provides a visual indication of the status of the device. When the controller receives power, the LED appears in one of the following allowable states, as described in [Table 12](#).

**Table 12: Status LED States**

LED State	Blink Rate	Status or Condition
OFF	not applicable	No power to processor, LED damaged, low voltage to board, first second of power up or loader damaged.
ON	ON steady; not blinking	Processor not operating. Application Program CRC being checked. This takes 1-2 seconds and occurs on each restart (powerup, reset and reflash, and following configuration file download).
Very slow blink (continuous)	1 second ON, 1 second OFF	Controller is operating normally.
Slow blink (continuous)	0.5 second ON, 0.5 second OFF	Controller alarm is active or controller in process of configuration file download.
Medium blink (continuous)	0.3 second ON, 0.3 second OFF	Controller is in Reflash mode or awaiting/receiving reflash data via the BACnet network.

**Bacnet Status Led**

The LED on the front of the controller, between the BACnet MS/TP terminals and MAC Address DIP Switches, provides a visual indication of the BACnet MS/TP communication status. When the controller receives power, the LED appears in one of the following allowable states, as described in Table 13.

**Table 13: BACnet Status LED States**

BACnet LED Status	Status or Condition
Solid on.	Controller has power, loader is not running.
Solid on, blinking off once in 2.5 sec.	Controller is in reflash mode, no MS/TP communication.
Solid on, blinking off twice in 2.5 sec.	Controller is in reflash mode, MS/TP communication present.
Solid on, blinking off three times in 2.5 sec.	Controller is in reflash mode, MS/TP communication data transfer in progress.
Solid off, there is no power	No power to processor, LED damaged, low voltage to board, or loader damaged.
Solid off, blinking on once in 2.5 sec.	Controller is running, no MS/TP communication
Solid off, blinking on twice in 2.5 sec.	Controller is running, MS/TP communication present.
Solid off, blinking on three times in 2.5 sec.	Controller is running, MS/TP communication data transfer in progress.

**Step 3: Checkout Completion**

At this point, the controller is installed and powered. To complete the checkout, the NIAGARA FRAMEWORK® application (run on a PC) is used to configure the I/O and functions of the controller. Refer to the Programming Tool User Guide, form no. 63-2662, for controller configuration and programming details.

	<b>Caution:</b>
<p><i>Fire, Explosion, or Electrical Shock Hazard can cause severe injury, death or property damage.</i></p> <p><i>Do not attempt to modify the physical or electrical characteristics of this device in any way. Replace the controller if troubleshooting indicates a malfunction.</i></p>	

	<b>Caution:</b>
<p><i>Electrical Shock Hazard can cause severe injury, death or property damage.</i></p> <p><i>Disconnect power supply before beginning controller replacement to prevent electrical shock or equipment damage.</i></p>	

**Terminal Block Removal**

To simplify controller replacement, all terminal blocks are designed to be removed with the wiring connections intact and then re-installed on the new controller. Refer to

[Figure 35](#) and refer to the following procedure:

	<b>Important:</b>
<p><i>To prevent bending or breaking the alignment pins on longer terminal blocks, insert the screwdriver at several points to evenly and gradually lift up the terminal block. Insert the screwdriver blade no more than 1/8 in. (3 mm) to prevent damage to the terminal block alignment pins on the controller circuit board.</i></p>	

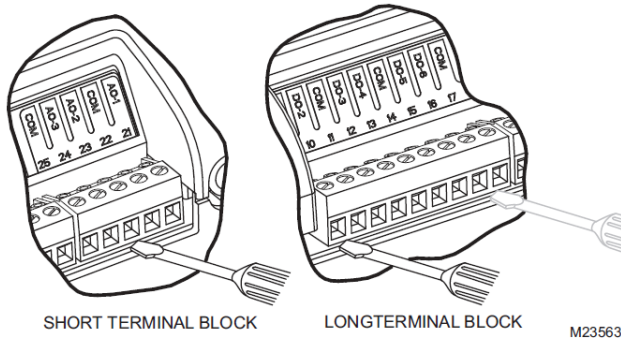

**Figure 20: Removing Terminal Blocks**

1. Use a thin-bladed screwdriver to evenly raise the terminal block from its alignment pins:
  - a. For short terminal blocks (1 to 5 terminals), insert screwdriver blade in the center of the terminal block and use a back and forth twisting motion to gently raise the terminal block from its alignment pins 1/4 in. (6.35 mm).
  - b. For long terminal blocks (6 or more terminals), insert screwdriver blade on one side of the terminal block and gently rotate the blade 1/4 turn. Then, move to the other side of the terminal block and do the same. Repeat until the terminal block is evenly raised 1/4 in. (6.35 mm) from its alignment pins.
2. Once the terminal block is raised 1/4 in. (6.35 mm) from its alignment pins, grasp the terminal block at its center (for long terminal blocks grasp it at each end) and pull it straight up.

### Controller Replacement

Perform the following to replace the controller:

1. Remove all power from the controller.
2. Remove the terminal blocks (Refer to "Terminal Block Removal").
3. Remove the old controller from its mounting.



**Important:**

(FOR CONTROLLERS MOUNTED TO A DIN RAIL):

1. Push straight up from the bottom to release the top pins.
2. Rotate the top of the controller outwards to release the bottom flex connectors (Figure 8).
3. Mount the new controller.
4. Replace the terminal blocks:
  - a. Insert each terminal block onto its alignment pins.
  - b. Press straight down to firmly seat it.
  - c. Repeat for each terminal block.
5. Restore power to the controller.
6. Perform "Checkout."

# SOFTWARE

## Introduction

VAV controller is a configurable controller. To configure the controller as per application requirement, the system details, specifications, control sequence and design parameters of the system are required.

## VAV Configuration Requirement

VAV controller can be configured using two methods:

1. With WEBStation-AX Software Tool
2. Through TR75 Wall Module

### With WEBStation-AX Software Tool

In the WEBStation-AX™ software tool, VAV Configuration Wizard application is integrated for VAV controller configuration.

#### 1. Configuration through PC

VAV controller can be accessed with the personnel computer with WEBStation-AX™ software tool installed on it. A VAV controller can be accessed for configuring, uploading and downloading operations through BACnet adaptor, which connects a PC through an Ethernet cable.

#### 2. Configuration through WEBS Controller

If the VAV controller is connected to the BACnet network of WEBS controller, it can be accessed through WEBS controller using PC with WEBStation-AX™ tool installed on it.

When WEBS controller is already commissioned, then it can be accessed through IP address with personnel computer without WEBStation-AX software tool installed on it. All required operations on the Stryker VAV controller can be performed by accessing WEBS controller through Web browser.

### Through TR75 Module

Configurable network parameters are also accessible through TR75 wall module. From the wall module, VAV application can be configured as per requirement. Access to the configurable parameters is password protected with default password 0000. For details, refer to 'Stryker VAV Zio Configuration Guide.'

## Configuration

Table 14: Configuration Options

Option	AscBACnetVAV Possible Configurations
Damper Control	1. Series 60 floating actuator
	2. Pulse width modulating actuator
	3. Analog actuator
Fan	1. None
	2. Parallel Temperature
	3. Parallel Flow
	4. Parallel Analog
	5. Series
	6 Parallel Floating
	7. Parallel PWM
Type of Reheat Coil	1. One stage
	2. Two stages
	3. Three stages
	4. Series 60 Modulating electric valve, or pneumatic via transducer
	5. Pulse Width Modulating electric valve, or pneumatic via transducer
	6. Analog

Type of Peripheral Heat	1. One stage
	2. Series 60 Modulating electric valve
	3. Pulse Width Modulating electric valve
	4. Analog
Window Open Option	1. BACnet object
	2. Local Window Open Digital Input - directly wired to the controller. (Configurable as normally open / closed.)
Monitor switch Option	1. BACnet object
	2. Local Monitor switch (general purpose) Digital Input - directly wired to the controller. (Configurable as normally open / closed.)
Occupancy Sensor Option	1. BACnet object
	2. Local Occupancy sensor Digital Input - directly wired to the controller. (Configurable as normally open / closed.)
Heat/Cool Changeover Switch Option	1. None
	2. Local Heat/Cool change over switch Digital Input directly wired to the controller. (Contacts closed means select Heat Mode.)
Wall Module Option	1. Local (direct wired to the box). Both T7770/TR2X models and the Sylk-based Zio (TR71/ T5) models are supported
	2. Shared (wired to another box)
Air Temperature Sensor	1. Discharge Air Temperature
	2. Supply Air Temperature
	3. Outdoor air temperature and humidity

**Reheat Type:** Elec\_ThreeStage or (Elec\_ThreeStageBin), (Elec\_OneStage).

**Proportional Reheat Flow:** Enable.

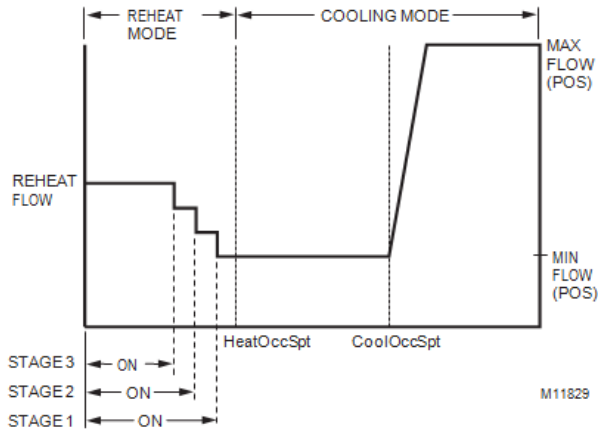

**Figure 21: VAV box modes for Reheat Type Elec\_ThreeStage - Proportional**

**Reheat Type:** Elec\_ThreeStage or (Elec\_ThreeStageBin), (Elec\_OneStage), (Elec\_TwoStage).

**Proportional Reheat Flow:** Disable.

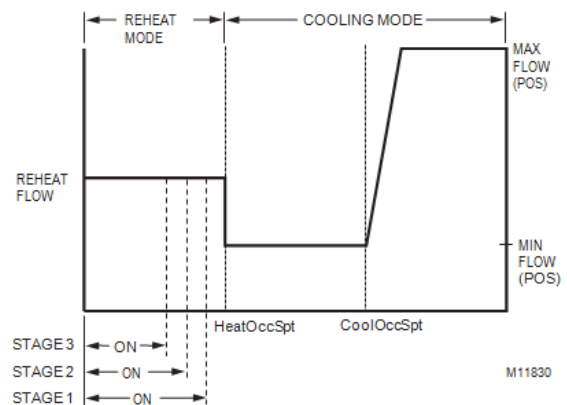

**Figure 22: VAV box modes for Reheat Type Elec\_ThreeStage - Non-Proportional**

Refer to [Figure 22](#) to see VAV box modes for Reheat type Elec\_ThreeStage - Non-Proportional.

**Pressure Type:**

Pressure Independent or (Pressure Dependent).

**Reheat Type:** Analog, Float or PWM.  
**Peripheral Heating Type:** Analog, Float or PWM.  
**Proportional Reheat Flow:** Enable.  
**Discharge Air Control For Reheat:** Normal Sequence.

**Periph Min Pos:** 0% or greater.

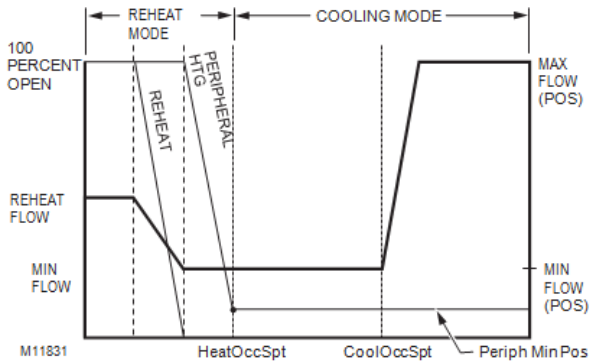

**Figure 23: VAV box modes for Reheat type Peripheral Heating Then Reheat - Proportional (Float\_Periph\_Reheat/PWM\_Periph\_Reheat)**

Refer to Figure 24 to see VAV box modes for Reheat type ReheatThenPeriph – Non-Proportional.

**Pressure Type:**  
 Pressure Independent or (Pressure Dependent).

**Reheat Type:** Float\_Reheat\_Periph or (PWM\_Reheat\_Periph).

**Proportional Reheat Flow:** Enable.

**Periph Min Pos:** 0% or greater.

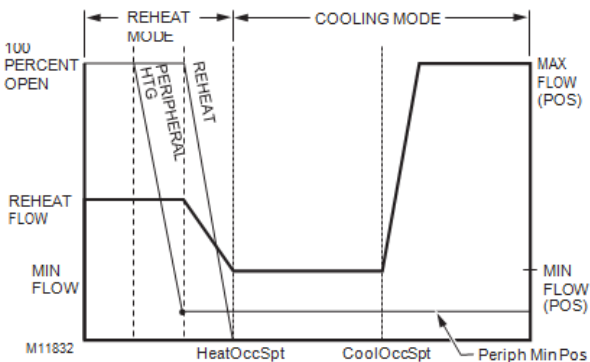

**Figure 24: VAV box modes for Reheat Type Elec\_ThreeStage - Non-Proportional**

**Reheat Type:** Analog  
**Peripheral Heating Type:** PWM.  
**Proportional Reheat Flow:** Enable.

**Discharge Air Control For Reheat:** Discharge Air Control Sequence

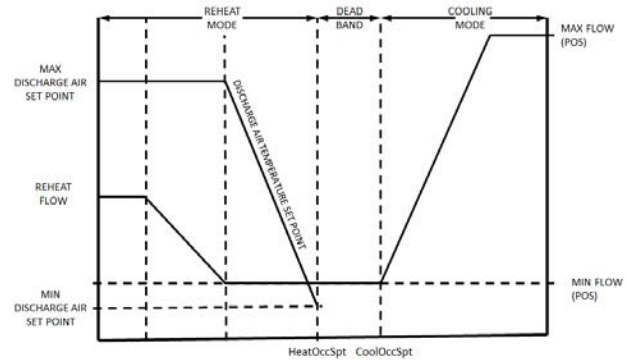

**Figure 25: VAV box modes for Reheat type Peripheral Heating Then Reheat Discharge Air Control Sequence - Proportional**

**Note:**  
 For sequence of operations of Discharge Air Temperature For Reheat, refer to [Discharge Air Control Sequence](#).

**Reheat Type:** FloatHotDuctPrDep.

**Proportional Reheat Flow:** Disable.

**Periph Min Pos:** 0% or greater.

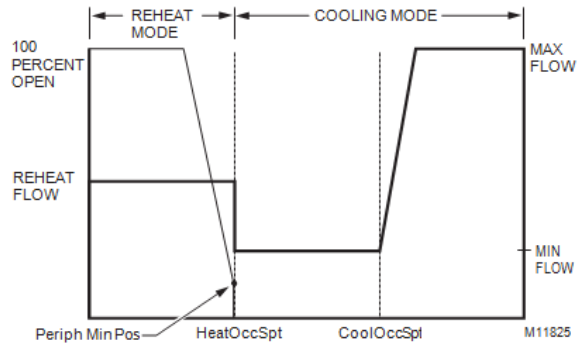
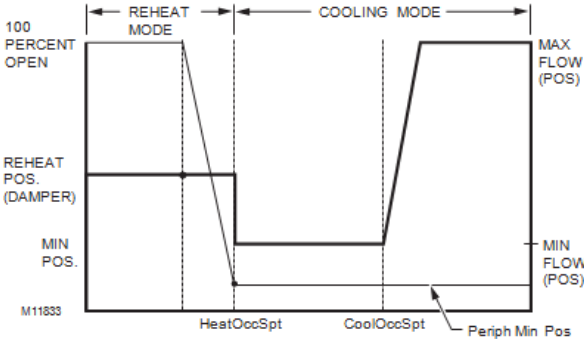

**Figure 26: VAV box modes for Reheat Type Float\_Reheat/ Float\_Periph, no minimum position, reheat goes to zero percent in cooling mode Non-proportional (suited for Reheat control because the Reheat closes to zero percent at HeatOccSpt)**

**Reheat Type:** Float\_Reheat/Float\_Periph.

**Proportional Reheat Flow:** Disable.

**Periph Min Pos:** 0% or greater.



**Figure 27: VAV box modes for Pressure Dependent, Reheat Type Float Reheat/Float\_Periph**

A Series fan is intended to run continuously when the main air handler is on and is in-line with the primary airflow through the box. This configuration is sometimes referred to as Variable Volume Supply with Constant Volume Discharge (VVS/CVD).

	<b>Note:</b>
<p>The location of the heating coils can be in the discharge, as shown in <a href="#">Figure 28</a>, or in the plenum return.</p>	

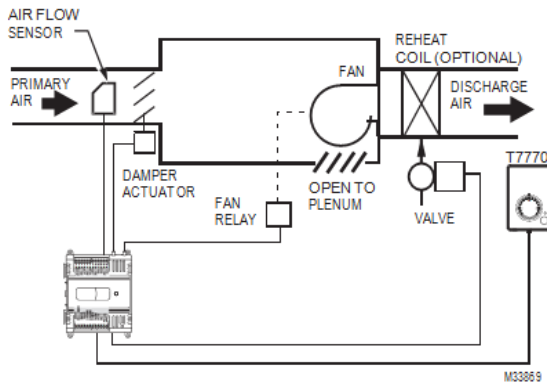

**Figure 28: Series VAV box fan**

A parallel fan, see [Figure 29](#), is not located in the primary air stream, but is designed to add return air from the plenum into the air stream delivered to the space. The Controller turns on the parallel fan when the space temperature falls below Setpoint as a first stage of reheat (Parallel Temp), or if the airflow falls below a minimum airflow setpoint to maintain a minimum airflow to the space (Parallel Flow).

	<b>Note:</b>
<p>The location of the heating coils can be in the discharge, as shown in <a href="#">Figure 29</a>, or as part of the plenum air return, either before or after the fan.</p>	

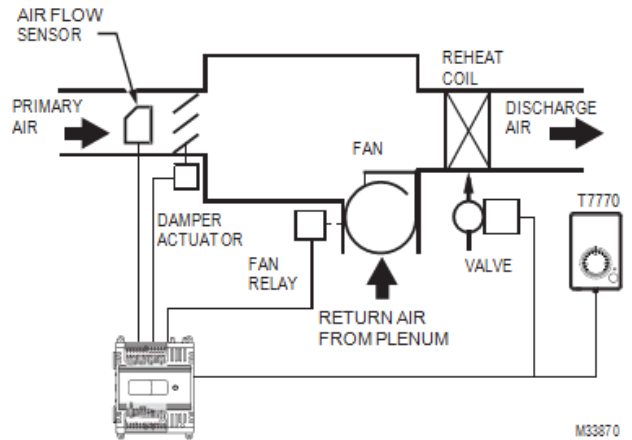

**Figure 29: Parallel VAV Box Fan**

See [Figure 30](#) and [Figure 31](#) to see the Heat/Cool Modes for Parallel Temperature/Flow VAV box fans.

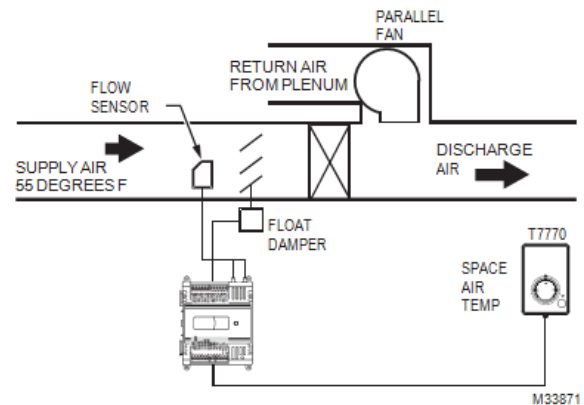
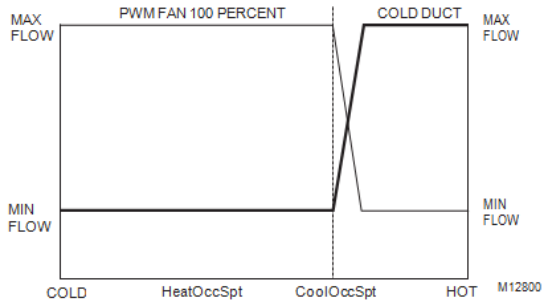

**Figure 30: Single Duct, Pressure Independent Cooling, with Analog Parallel Fan**

**Parallel Analog – Fan**

Use this only with single duct configurations. The Analog fan is a variable speed fan that controls the amount of return air or return plenum air to the space. The Analog fan acts in opposite to the cooling duct damper position for pressure dependent operation, or in opposite to the cooling duct flow for pressure independent.

Refer to [Figure 31](#) for Modes for Single Duct, Pressure Independent Cooling, with Parallel Fan.



**Figure 31: Modes for Single Duct, Pressure Independent Cooling, with Parallel Fan**

**Exhaust Tracking Flow Control**

An example of Exhaust Tracking is shown in [Figure 32](#). To configure Exhaust Tracking Flow Control Application in the tool, follow the configurations shown in the table below (Refer to “Flow balancing”).

CVB Controller	Box Type Selected in the Tool	Flow Type Selected in the Tool
1	Single Duct	SD_Normal_Flow
2	Single Duct	SD_Normal_Flow
3	Single Duct	SD_Normal_Flow
4	Flow Tracking	FLOW_Tracking

Additionally, Bind the FlowTrackOut (AV-1148) of controller number 1 to the FlowTrackIn (AV-1189) of number 2, the FlowTrackOut (AV-1148) of number 2 to the FlowTrackIn (AV-1189) of number 3, the FlowTrackOut (AV-1148) of number 3 to the FlowTrackIn (AV-1189) of number 4.

**Flow Tracking Application Notes:**

1. Flow tracking is intended for noncritical, slow responding commercial building zone pressurization control sequences. This means that average pressurization can be maintained if disturbances are slow acting, but fast disturbances may result in temporary short-term imbalances. Do not apply the VAV Flow Tracking option in life safety or industrial environments such as clean rooms, fume hoods, or bio hazard control.
2. Flow tracking requires high resolution airflow damper actuators. Floating actuators are recommend.



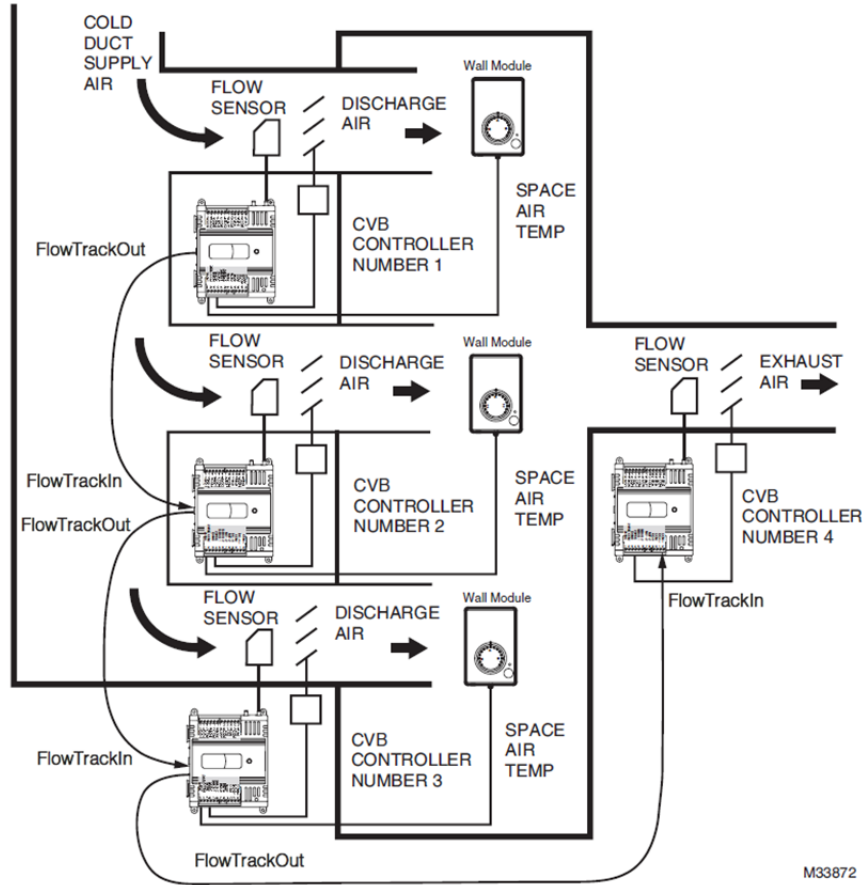

M33872

**Figure 32: Exhaust Tracking Flow Control**

### Share Wall Module

An example of sharing wall modules between three VAV controllers (Wall Module is hard-wired to Controller 1 in the figure) is shown in Figure 32. To configure Exhaust Tracking Flow Control Application in the tool, follow the configurations shown below (Refer to “Flow balancing”).

CVB Controller	Flow Type Selected in the Tool	Box Type Selected in the Tool	Wall Module Type
1	Flow Normal	Single Duct	Conventional/TR71-75
2	Share wall Module	Single Duct	No Sensor
3	Share wall Module	Single Duct	No Sensor
4	Flow Tracking	Single Duct	No Sensor

Bind (ModeShareOut, ReheatCmdOut, PeriphCmdOut and TempFlowCmdOut) of VAV number 1, as Source controller, to the (ModeShareIn, ReheatStgsShareIn, ReheatCmdIn, TempFlowCmdIn, EffectOccIn, PeriphStgIn and PeriphCmdIn) of VAV number 2 through VAV number 4, as the Destination controller. The source device share outputs should include (ReheatStgsOut, EffectOccOut and PeriphHtgStgsOut). The user only has to bind the appropriate AVs that are required for the configuration used (i.e. Staged versus Modulating). The destination devices must have the same configuration as the source.

## Accessory Loops

The AscBAcnetVAV Controller can be configured with up to two accessory loops that are used to command outputs based on an input variable. These loops have many built in features enabling them to command a wide variety of applications.

The fundamental operation of a control loop compares the value of the input sensor (measured variable) to the setpoint and calculates the output using the PID parameters.

Each control loop can configure the primary output as either analog or staged (1 to 3 stages). Each control loop also has an auxiliary DO for controlling a fan or a pump. Configured accessory loops run once per second.

## PID Control

The actual PID control algorithm is more complex. It can be explained as follows where:

O = Control signal output. V = Calculated output.

M = Output Bias.

Ep = Proportional Error.

Ep-1 = Ep from the previous iteration. Ei = Integral Error.

Ed = Derivative Error.

Sen = Input sensor value.

SP = Setpoint.

TR = Throttling Range. Ti = Integral Time.

Td = Derivative Time.

$O = \text{If } (V \times 100\% + M) < 0\% \text{ Then } 0\%$

$\text{Else if } (V \times 100\% + M) > 100\% \text{ Then } 100\%$

$\text{Else } (V \times 100\% + M)$

$V = E_p + E_i + E_d$

Direct Acting or Reverse Acting

$$E_p = \frac{\text{Sen} - \text{SP}}{\text{TR}}$$

$$E_p = \frac{\text{SP} - \text{Sen}}{\text{TR}}$$

$$E_i = \sum_i \frac{E_p}{T_i}$$

$$E_d = (E_{p-1} + E_p) \times E_d$$

## Proportional Control

Proportional control is the function that determines the output setting required to meet the load conditions. Refer to Figure 33 and Figure 34.

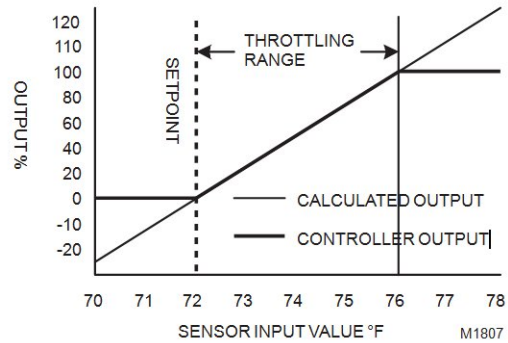

Figure 33: Proportional Direct Acting (Cooling)

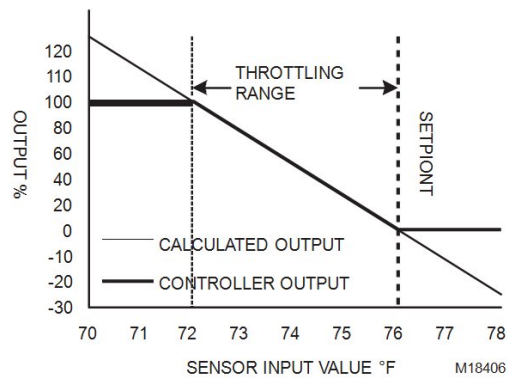

Figure 34: Proportional Reverse Acting (Heating)

In a direct acting control loop, the output increases as the input sensor value rises above the setpoint. In a reverse acting control loop, the output increases as the input falls below the setpoint. Direct and reverse acting are selected based on application requirements associated with the consideration that the setpoint is the no load value of a measured variable because it has 0 percent output when the energy input is closed or off. The physical outputs are configured to match the controlled devices (for example, normally open, normally closed, energized on, and energized off).

Direct Acting Cooling	Reverse Acting Heating
Dehumidification	Humidification
Mixed Air	Hot Water Pump
Static Pressure	Lighting
Chilled Water Pump	
Condenser Water Pump	

The proportional calculation determines the proportional error ( $E_p$ ).  $E_p$  is the deviation from the setpoint of the sensed medium (input sensor) divided by the throttling range in the units of the input sensor. The setpoint is the value of the input sensor that satisfies the control loop. When the input sensor value is at the setpoint, there is no proportional error and the output is 0 percent. The throttling range is the amount of change in the sensed medium that is required to drive the output from 0 to 100 percent. In proportional control, the input value must deviate from the setpoint to initiate a change in the output.

The throttling range must be narrow enough to provide good control without becoming unstable. The throttling range is determined by a number of factors such as the control application, the response time to the equipment being controlled and the control algorithm in use. The narrower (smaller) the throttling range, the more precise the control operation. The wider (larger) the throttling range, the more stable the control action. The objective is to set the throttling range to achieve the optimum balance between precision and stability.

### Integral Control

The purpose of the integral function is to eliminate the offset inherent in proportional control. Integral control functions to hold the input sensor value at setpoint.

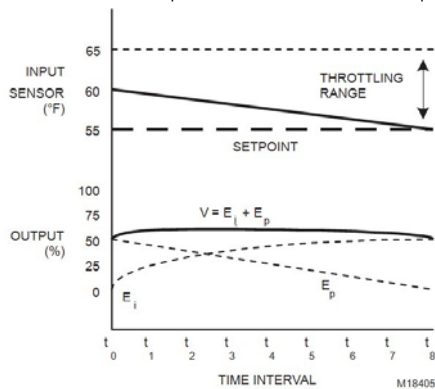

Figure 35: Proportional Integral Control

The integral function is a result of proportional error and time. When the proportional error is greater than 0, the integral error is calculated and added to the proportional error to determine the control loop output. The integral error is cumulative and continues to increase as long as the proportional error is greater than 0. The increase in the output signal drives the controlled device further open and the controlled medium is brought closer to the setpoint. While the proportional error is reduced, the integral error continues to increase until the proportional error is eliminated. When the proportional error equals 0, the calculated integral error is no longer increasing or decreasing and no change is made to the output. When the proportional error is less than 0, the integral error decreases in value.

The integral time value is set in seconds based on the lag time of the controlled process. A slow process such as space temperature control requires a long integral time (600 seconds or more), while a fast process such as static pressure control requires a short integral time. An integral time of 0 (default) eliminates the integral function for the control loop.

Stability of the PI control loop is a balance of the throttling range and the integral time. If a PI control loop is unstable, increase the throttling range and/or increase the integral time. Generally, the throttling range required for PI control is greater than what is used for proportional control only. PI control should only be used in closed loop applications. Without feedback from the controlled medium, integral windup occurs. Integral windup is a run away condition in which the integral error continues to increase due to the lack of proportional corrections. Plan the control strategy to insure integral windup does not occur or cause problems in the system performance.

## Derivative Control

The purpose of derivative control is to reduce ringing or severe overshoot and undershoot when there is a significant load change in a short period of time. Refer to [Figure 36](#), [Figure 37](#) and [Figure 38](#).

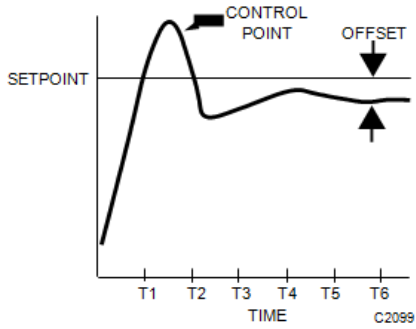

**Figure 36: Proportional Control**

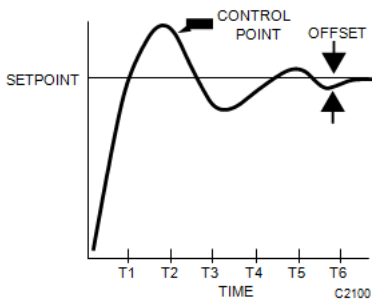

**Figure 37: Proportional Integral Control**

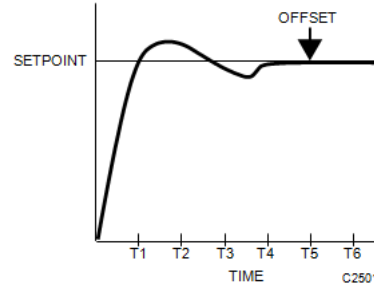

**Figure 38: Proportional Integral Derivative Control**

	<b>Note:</b>
<p><i>Few applications in HVAC require the use of derivative control. The loop stability and time associated with tuning derivative loops dictates that derivative not be used unless necessary.</i></p>	

## Control Loop Inputs

The control loop has seven control inputs plus four setpoint override inputs, each has a specific purpose. Only the Main Sensor is required for control loop operation. All other sensors are optional depending on the application that the control loop is configured for:

Input Name	Type	Description
Main Sensor	Analog	The input sensor is used in the PID loop to calculate the required output positions. This is also referred as the primary sensor. This input must be configured to have a control loop that is configured. If a fault (for example: open, short or loss of data) occurs on the main sensor, the control loop stops and all outputs are set to start value (usually 0) percent or off.
Reset Sensor	Analog	This sensor resets the occupied setpoint when the reset input is configured. Refer to <a href="#">Setpoint Reset</a>
Occupancy Sensor	Digital	Reset for more information.
Loop Disable Input	Digital	The occupancy sensor is used to determine the effective setpoint
Setpoint Input	Analog	This input disables the loop when the input is active (on, true). The loop is enabled when the input is inactive (off, false).

## Accessory Loop Outputs

### Output Operation

A control loop calculates an output value of 0 to 100 percent for each configured control loop output. Analog outputs will be positioned proportionally to the output value based on the output configuration. Staged outputs are configured with one to three digital outputs. Minimum off and on times can be configured and apply to all stages configured for the control loop output. Interstage on-off times can be configured and apply to all stages configured for the control loop output. Interstage time is the time lapse required before the next stage can be switched on or off. The time should be set to match the mechanical system response time.

Aux Output Operation; the Aux (auxiliary) Output is a digital output that works like the fan output on a commercial thermostat. The Aux output can be configured for either continuous or intermittent operation. This selection applies to occupied and standby operation. Unoccupied is always intermittent. In continuous operation, the output is on continuously, regardless of the operation of the other control loop outputs. In intermittent operation, the output is on only when an analog output value is greater than 0 or at least

one staged output is on. The Aux output can be configured with minimum off and on times.

For a detailed description of the configurations available for the accessory loops.

The derivative control function opposes change. The greater the proportional error the greater the braking effect of derivative control. The derivative function is calculated by subtracting the current proportional error value from the proportional error value of the previous loop execution and multiplying the result by the derivative time in seconds. The derivative error is summed with the proportional and integral errors to determine the loop output value.

In selecting the derivative time setting, the smaller the time setting, the smaller the derivative effect and the greater the time setting, the greater the derivative effect. A derivative time of 0 (default) eliminates the derivative error. If using the derivative time, it must be set to match the system response time of the controlled equipment and significantly impacts the throttling range and integral time settings. There are no application specific

*STRYKER VAV CONTROLLER*

settings for the derivative time as the settings are unique to the equipment and load conditions.

## Effective Setpoint Calculation

### Effective Setpoint

When working with control loops there is a distinction between the program setpoints and the effective setpoint. The program setpoints are the values entered into the controller program for the occupied, standby and unoccupied setpoints for each control loop that is configured. These values can be changed at any time from an operator interface or the tool. These setpoints are the initial values used in calculating the effective setpoint. The effective setpoint is the actual setpoint value used in a control loop to perform the PID calculations. It is the result of programmed and calculated setpoint values that are controlled by time and events. All setpoint values are in units of the main input sensor. If a Setpoint input is configured and is valid, the effective setpoint value is equal to the setpoint input value. If no Setpoint input is active, the effective setpoint value is equal to the setpoint determined by the current occupancy mode.

Occupancy State	Meaning
OCCUPIED	The space is considered occupied and the control loop uses the occupied effective setpoint.
STANDBY	The space is considered to be in standby, a state between occupied and unoccupied, with the control loop using the standby effective setpoint.
UNOCCUPIED	The space is considered unoccupied and uses unoccupied setpoint.
BYPASS	The space is considered occupied but is not scheduled to be occupied and the control loop uses the occupied effective setpoint.

The accessory loop determines the occupancy state based on the configured occupancy input. Occupancy input can be configured as a local digital input or can also be configured to use the effective occupancy status of the main VAV application. Alternately, the scheduled occupancy state can also be configured to be used as the occupancy input for the accessory loop.

### Setpoint Reset

Setpoint reset uses the reset input to reset (raise or lower) the control loop setpoint. The amount of the reset and the range of the reset input used to reset the setpoint are configurable. The reset input is an AI and can be configured either as a local input connected to

one of the UI pins or as a BACnet object (Free1ModIn). The reset input can also be configured as one of the following VAV application values: space temperature, space humidity, space CO<sub>2</sub> value, supply temperature, discharge temperature or the Flow pressure value.

If the reset input is not configured, setpoint reset is not applicable to the control loop operation.

Setpoint reset requires following parameters to be configured in the tool: Min. Reset Sensor Value, Max Reset Sensor Value and the corresponding minimum and Maximum Reset Amount.

Minimum Reset Sensor Value is the reset input value at which the configured minimum reset value is applied. Max Reset Sensor Value is the reset input value where the maximum reset is achieved. (Example: Effective Setpoint equals Occupied Setpoint plus Max Reset Sensor Amount.) Max Reset Amount is the maximum amount the Effective Setpoint can change from the occupied setpoint as the reset input value varies from the Minimum Reset Sensor Value to the Max reset sensor value.

The accessory loop determines the occupancy state based on the configured occupancy input. Occupancy input can be configured as a local digital input or can also be configured to use the effective occupancy status of the main VAV application. Alternately, the scheduled occupancy state can also be configured to be used as the occupancy input for the accessory loop.

Setpoint reset is designed to operate in the energy saving direction. Direct acting control loops are reset up from the occupied setpoint. Reverse acting control loops are reset down from the occupied setpoint.

### Control Loop Inputs

The control loop has seven control inputs plus four setpoint override inputs, each has a specific purpose. Only the Main Sensor is required for control loop operation. All other sensors are optional depending on the application for which the control loop is configured.

### Accessory Loop Examples

Heating loop with a modulating valve using a fixed setpoint, which is different from the main application

1. From **Outputs** tab
  - a. Select "Analog Control" from the Modulating Output pulldown

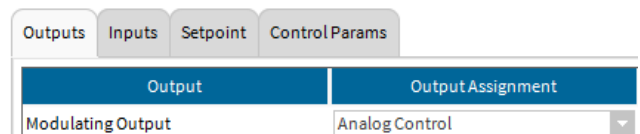

- b. Configure the type of analog control from the menu below

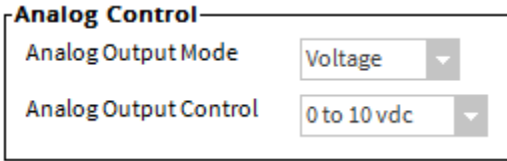

2. From **Inputs** tab
  - a. Select an input from the Main Sensor pulldown, e.g. TR2x 20Kntc

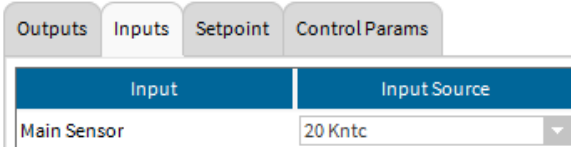

**Note:**

*This input is the space sensor located in the zone in which the modulating actuator is controlling temperature. Alternatively the sensor from the main application could be used by choosing "Main Application Output" and selecting "SpcTempLogical" from the Input Name pulldown*

3. From the **Setpoint** tab
  - a. Enter the desired setpoint in the Occupied box

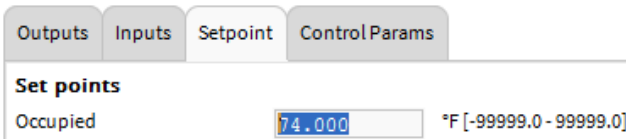

**Note:**

*The rest of the Setpoints and Setpoint Reset fields are ignored since Setpoint and Occupancy Status were not chosen on the Inputs tab*

4. From **Control Params** tab
  - a. Enter the desired setpoint in the Occupied box



5. Assign the desired terminals from the Custom Wiring tab

**Heating loop with a modulating valve using the effective heating setpoint from the internal application**

1. From Outputs tab
  - a. Select "Analog Control" from the Modulating Output pulldown
  - b. Configure the type of analog control from the menu below
2. From Inputs tab
  - a. Select an input from the Main Sensor pulldown, e.g. TR2x 20Kntc

**Note:**

*This input is the space sensor located in the zone in which the modulating actuator is controlling temperature. Alternatively the sensor from the main application could be used by choosing "Main Application Output" and selecting "SpcTempLogical" from the Input Name pulldown*

- b. Select "Main Application Output" from the Set Point pulldown

**Note:**

*Select "VAVHtgSP" from the Input Name pulldown.*

**Note:**

*If available, the wall module center setpoint could be used by selecting "WallModCntrSP"*

3. The Setpoints and Setpoint Reset fields are ignored since Setpoint and Occupancy Status were not chosen on the Inputs tab. The setpoint used will always follow the effective setpoint from the main application of the controller.
4. From Control Params tab
  - a. Choose the desired PID loop settings
5. Assign the desired terminals from the Custom Wiring tab

**Heating loop with a modulating valve using the Loop Occupied, Unoccupied and Standby setpoints and occupancy from the internal application**

1. From Outputs tab
  - a. Select "Analog Control" from the Modulating Output pulldown
  - b. Configure the type of analog control from the menu below
2. From Inputs tab
  - a. Select an input from the Main Sensor pulldown, e.g. TR2x 20Kntc



 **Note:**

*This input is the space sensor located in the zone in which the modulating actuator is controlling temperature. Alternatively the sensor from the main application could be used by choosing "Main Application Output" and selecting "SpcTempLogical" from the Input Name pull-down*

- b. Select Set "None" for the Point input Select "Main Application Output" from the Occupancy Status pull-down

 **Note:**

*Select "VavEffectiveOcc" from the Input Name pull-down*

- 3. From the Setpoint tab
  - a. Configure the appropriate values for Occupied, Standby and Unoccupied Set points.
- 4. The Setpoint Reset fields are ignored since the Set Point input is unassigned.
- 5. From Control Params tab
  - a. Choose the desired PID loop settings
- 6. Assign the desired terminals from the Custom Wiring tab

**Peripheral heat water temperature reset from a network outdoor air temperature**

Hot Water Reset Schedule	
Outdoor Temp (F)	Hot Water Temp SP (F)
65	100
10	180

- 1. Open the VAV Inputs Section
  - a. Select Outdoor Air Temperature Input Source as "BACnet object OdTemp Only". This step configures the logical value for outdoor air temperature.

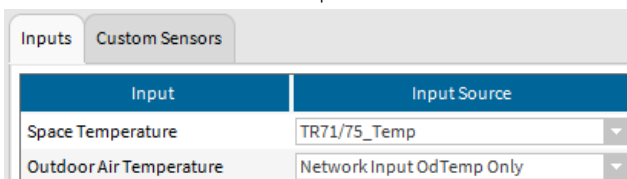

- 2. Open the Accessory Loops Section
- 3. From Outputs tab
  - a. Select "Analog Control" from the Modulating Output pull-down
  - b. Configure the type of analog control from the menu below
- 4. From Inputs tab
  - a. Select a 20Kntc sensor from the Main Sensor Input Source pull-down

 **Note:**

*This is the sensor for the hot water temperature control loop.*

- b. Select "Main Application Output" from the Reset Sensor pull-down

 **Note:**

*Select "OdTempLogical" from the Input Name pull-down*

- 5. From the **Setpoint** tab
  - a. Enter the desired design conditions (180 F hot water at 10 F outdoor air) peripheral hot water temperature setpoint at design conditions in the Occupied box

 **Note:**

*The Standby and Unoccupied values are ignored but can be set equal to the Occupied setpoint to avoid confusion if desired*

- b. Enter the desired values to determine the hot water setpoint based upon minimum and maximum outdoor temperatures.

 **Note:**

*In the following example, the hot water temperature will be 180 degrees when the outdoor air temperature is 10 degrees or below and the hot water temperature will be 100 degrees when the outdoor air temperature is 65 degrees or above. When the outdoor temperature is between 10 and 65 degrees, the setpoint will follow the line defined by those points*  
 Occupied Setpoint: 180,  
 Min Reset Sensor Value: 10,  
 Max Reset Sensor Value: 65

	<b>Note:</b>
Min Reset Amount: 0, Max Reset Amount: -80	

6. From **Control Params** tab
  - a. Choose the desired PID loop settings
7. Assign the desired terminals from the Custom Wiring tab

Lighting controlled from internal application occupancy using pulse on/off relays

An accessory loop is not necessary for pulsed lighting control. Select "Digital Control" for the Auxiliary Pulse On and Auxiliary Pulse Off in the VAV Outputs tab and the assigned DO's will follow the effective occupancy of the controller. On the Schedule configuration screen, you may choose whether the Standby period is treated as occupied or unoccupied

Auxiliary Pulse On	Digital Control
Auxiliary Pulse Off	Digital Control

### Fan control

An accessory loop is not necessary for simple exhaust fan control. Select "Digital Control" for the Auxiliary Digital Output in the VAV Outputs tab and the assigned DO will follow the effective occupancy of the controller. On the Schedule configuration screen, you may choose whether the Standby period is treated as occupied or unoccupied

Auxiliary Digital Output	Digital Control
--------------------------	-----------------

### Discharge Air Control Sequence

Heating loop with modulating valve has two sequences to modulating valve (Normal Sequence and Discharge Air Control Sequence). During Discharge Air Control Sequence, Analog reheat modulates to maintain discharge air temperature at setpoint. Discharge air temperature setpoint resets based on space temperature and occupied heating setpoint.

1. Open the VAV Outputs Section
  - a. Set Reheat Type to Analog Reheat
  - b. Set Peripheral Heating Type output to PWM (this output will not be used)

Reheat Type	Analog Reheat
Peripheral Heating Type	PWM Peripheral Heat

- c. Select **Heating Sequence** Mode (at bottom of page) as - Peripheral Heating then Reheat

Heating Sequence	
Sequence Mode	Peripheral Heating Then Reheat

2. Open the VAV Inputs Section
  - a. Select the Discharge Temperature Input source as the type of sensor a user is going to use
3. Open the Accessory Loops Section
4. From Outputs tab
  - a. Select "Analog Control" from the Modulating Output pulldown
5. From **Inputs** tab
  - a. For the Main Sensor Input Source select Shared Input
  - b. For the Main Sensor Input Name select Discharge temp
  - c. For the Loop Disable Input Source select Main Application Output
  - d. For the Loop Disable Input Name select DisableHtg
  - e. For the Reset Sensor Input Source select Main Application Output
  - f. For the Reset Sensor Input Name select PeriphHtgMod

Outputs Inputs Setpoint Control Params			
Input	Input Source	Input Name	
Main Sensor	Shared Input	Discharge temp	
Set Point	None	L1_Setpoint	
Loop Disable	Main Application Output	DisableHtg	
Occupancy Status	None	L1_Occ Status	
Reset Sensor	Main Application Output	PeriphHtgMod	

6. From the **Setpoint** tab
  - a. Set all of the set points (occ, stby, unocc) to the average supply air temp (typically 55)
  - b. Set the Minimum Reset Sensor Value to 0%
  - c. Set the Maximum Reset Sensor Value to 100%
  - d. Set the Min Reset Amount to 0 ( $\Delta^{\circ}\text{F}$ )
  - e. Set the Max Reset Amount to whatever you want the max discharge temp to be, minus the set point (chosen above) (i.e. if set points above are 55, and the desired max discharge temp = 95F, then set this to 40 ( $\Delta^{\circ}\text{F}$ ))

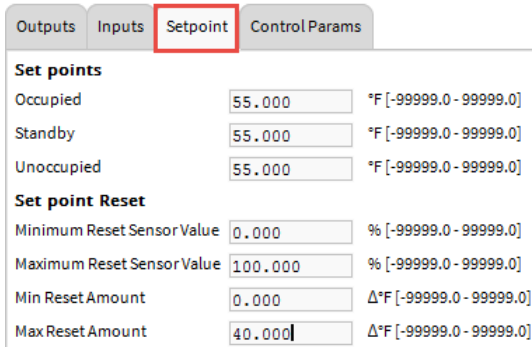

7. From **Control Params** tab
  - a. Set Throttling Range to 10 F (suggested)
  - b. Set Integral time to 500 s (suggested)
  - c. Derivative time to 0
  - d. Set PID action to Reverse
  - e. Wire the reheat to the Loop1-L1\_Mod Output (do not connect anything to the peripheral heat DO or the Reheat AO terminals)

## Flow Balancing

### Balancing using the Niagara Tool

The Niagara tool supports a custom view on the controller, which allows you to perform the following:

- Flow pressure zero calibration
- Two point calibration
- K factor calibration
- Heating coil water flow calibration

Note that the option to calibrate the reheat valve is available only when Modulating Reheat is configured and similarly the option to calibrate the peripheral heat valve is available only when Peripheral Heat is configured.

Note that the view allows you to view and edit some key parameters such as duct inlet area, K-Factor, occupied flow setpoints etc. that affect the airflow in the box. Review these parameters and correct them if required before starting the flow balancing procedure.

Procedure for airflow balancing:

- a. Flow pressure zero calibration:
 

To start zero balancing, click 'Start Zero Balancing'. The tool commands the controller to completely close the damper and waits until the damper position reports 0%. At this point, if any flow pressure is detected, then that value is considered as the flow pressure offset. The tool reads the flow

pressure from the controller and updates the pressure offset accordingly. After the completion of zero balancing, the device mode is set to automatic operation.

- b. Two point calibration

You can start either maximum or minimum balancing in any order. The tool does not enforce any rules about the balancing.

To start maximum calibration click 'Start Maximum Balancing'.

The tool commands the controller to the manual flow override mode and sets the flow setpoint as the configured maximum flow setpoint. The tool then continuously checks/monitors the controller to see whether the box flow reaches the setpoint. After the setpoint is attained, the Measured Flow field is enabled and the actual measured flow value can be specified. Note that the device remains in manual flow override mode (Open Maximum) after maximum balancing is complete.

To start minimum calibration, click 'Start Minimum Balancing'.

The tool commands the controller to the manual flow override mode and sets the flow setpoint as the configured minimum flow setpoint. The tool then continuously checks/monitors the controller to see whether the box flow reaches the setpoint. After the set point is attained, the Measured Flow field is enabled and you can specify the actual measured flow value. Note that the device remains in manual flow override mode (Open Minimum) after minimum balancing is complete.

To start K factor calibration method, click 'Start K Factor Balancing'.

(Note that when K-factor balancing is started, the two point calibration data is returned to factory defaults automatically by the tool before proceeding with the K-factor procedure.)

The tool commands the controller to manual flow override mode to try and attain the maximum flow setpoint. The tool then continuously checks/monitors the controller to see whether the box flow reaches the setpoint. After the setpoint is attained, the Measured Flow field is enabled and the actual measured flow value can be specified.

Based on actual the measured flow that is entered, the K factor value is calculated by the tool and displayed. The tool prompts you to write this value to the device. You can choose to calculate the K factor without using the tool and set the calculated value in the K factor field. Note that the device remains in manual mode (Open Maximum) after K factor balancing has been completed.

## Heating coil water flow calibration

When modulating reheat or modulating peripheral heat is configured, the Niagara tool allows you to override hot water valve positions.

To override the reheat valve position, type the reheat value in percentage and click the Override button next to Reheat Valve Override field.

To override the peripheral heat valve position, type the peripheral heat value in percentage and click the Override button next to the Peripheral Heat Valve Override field.

	<b>Note:</b>
<i>Click the Auto button to set the reheat and peripheral heat valve into automatic operation.</i>	

## Balancing via Zio

### Pressure Zero Calibration

1. Change the Wall Module to the contractor view
2. Navigate to Parameters, OVERRIDE, FLO\_OVRD.
3. Close the Primary Air damper: FLO\_OVRD = CLOS
4. Navigate to Parameters, STATUS, DAMPER
5. Wait for the damper to close: DAMPER = 0
6. Navigate to Parameters, SENSORS, PRS\_UCAL
7. Monitor the flow pressure signal for stability: PRS\_U-CAL
8. Navigate to Parameters, SNSR\_CAL, PRESS\_OF
9. Set the new zero offset: PRESS\_OF = PRS\_UCAL
10. Navigate to Parameters, SENSORS, FLOPRESS
11. Wait 10 sec and verify the new calibrated pressure: FLOPRESS ~ 0
12. Navigate to Parameters, OVERRIDE, FLO\_OVRD.
13. Return to normal operation, FLO\_OVRD = ----

### Zio - K Factor One Point Balance

1. Change the Wall Module to the contractor view
2. Navigate to PARAMETERS, FLO\_CNFG, AREASQFT
3. Verify that the correct duct Area is configured.
4. Obtain the factory zone terminal K factor from the manufacturer data sheet. If the K factor is unknown, use the value 1400.
5. Navigate to PARAMETERS, FLO\_CNFG, K FACTOR
6. Set the factory K factor.
7. Navigate to PARAMETERS, AIRFLOSP, MAX\_FLO
8. Verify the value of MAX\_FLO setpoint.
9. Navigate to PARAMETERS, BALANCE, K\_OFFSET

10. Verify that K\_OFFSET = 0.
11. Navigate to PARAMETERS, OVERRIDE, FLO\_OVRD.
12. Set VAV box override to the maximum occupied airflow setpoint: FLO\_OVRD = HISP
13. Navigate to PARAMETERS, SENSORS, AIRFLOW
14. Monitor the AIRFLOW value.
15. After the airflow has settled to a stable value, measure the actual airflow with a calibrated instrument.
16. Navigate to PARAMETERS, SENSORS, FLOPRESS
17. Monitor the flow pressure.
18. Calculate the new K factor:  $K_{FactorNew} = \text{Airflow Measured} / (\text{FLOPRESS})^{1/2}$
19. Calculate the K factor Offset:  $K\_OFFSET = K_{FactorNew} - \text{factoryKfactor}$
20. Navigate to PARAMETERS, BALANCE, K\_OFFSET
21. Set the new K factor Offset value.
22. Navigate to PARAMETERS, OVERRIDE, FLO\_OVRD
23. Return system to normal: FLO\_OVRD = ----

### Zio - Two Point Balance

1. Change the Wall Module to the contractor view
2. Navigate to PARAMETERS, FLO\_CNFG, AREASQFT
3. Verify that the correct duct Area is configured:
4. Obtain the factory zone terminal K factor from the manufacturer data sheet. If the K factor is unknown, use the value 1400.
5. Navigate to PARAMETERS, FLO\_CNFG, K
6. Set the factory K factor.
7. Navigate to PARAMETERS, AIRFLOSP, MIN\_FLO
8. Verify the value of minimum flow setpoint.
9. Navigate to PARAMETERS, AIRFLOSP, MAX\_FLO
10. Verify the value of maximum flow setpoint.
11. Navigate to PARAMETERS, BALANCE, K\_OFFSET
12. Verify that K\_OFFSET = 0.
13. Navigate to PARAMETERS, OVERRIDE, FLO\_OVRD.
14. Set VAV box override to the minimum occupied airflow setpoint: FLO\_OVRD = LOSP
15. Navigate to PARAMETERS, SENSORS, AIRFLOW
16. Monitor the AIRFLOW for stability at the minimum set-point value.
17. Navigate to PARAMETERS, BALANCE, MINFLOSP
18. Set the minimum measured flow setpoint:  $MINFLOSP = \text{Avg}(\text{AIRFLOW})$
19. Measure the actual flow with a calibrated instrument.
20. Navigate to PARAMETERS, BALANCE, MIN\_FLOW
21. Set the measured minimum flow calibration value:  $MIN\_FLOW = \text{measuredValue}$
22. Navigate to PARAMETERS, OVERRIDE, FLO\_OVRD.

23. Set VAV box override to the maximum occupied airflow setpoint: FLO\_OVRD = HISP
24. Navigate to PARAMETERS, SENSORS, AIRFLOW
25. Monitor AIRFLOW value for stability at the maximum airflow setpoint value.
26. Navigate to PARAMETERS, BALANCE, MAXFLOSP
27. Set the maximum measured flow setpoint: MAXFLOSP = Avg (AIRFLOW)
28. After the airflow has settled to a stable value, measure the actual airflow with a calibrated instrument.
29. Navigate to PARAMETERS, BALANCE, MAX\_FLOW
30. Set the measured minimum flow calibration value: MAX\_FLOW = measured Value
31. Navigate to PARAMETERS, OVERRIDE, FLO\_OVRD
32. Return system to normal: FLO\_OVRD = ----

### Zio - Water Flow Calibration

1. Navigate to PARAMETERS, OVERRIDE, RH\_OVRD
2. Set the reheat hot water valve position to the desired value using: RH\_OVRD = (0 to 100%)
3. Implement balancing adjustments.
4. Reset the reheat hot water valve override to automatic control: RH\_OVRD = ----
5. Navigate to PARAMETERS, OVERRIDE, PHT\_OVRD
6. Set the peripheral heat valve position to the desired value using: PHT\_OVRD = (0 to 100%)
7. Implement balancing adjustments.
8. Reset the peripheral water valve override to automatic control: PHT\_OVRD = ----

### Alarm Reporting

The controller is capable of tracking and reporting several types of errors. Groups of errors of the same type are also reported as an alarm by the controller using AV\_AlarmH. This means that several different errors of the same type will be reported as a single alarm. For Example, multiple sensors connected to the controller may read invalid values and the controller will log individual errors for each sensor. However, a single 'SensorFailure' alarm will be reported.

The following Objects report errors and alarms:

AV\_Error0, AV\_Error1, AV\_Error2, AV\_Error3.....

AV\_Error15: This contains a list of all of the current errors detected by the device. This list is the most granular.

Errors are combined together into alarms. There may be one to many errors represented by each alarm. See the table below for a mapping of error bits to alarms.

(LowFlowAlarmOut, AirFlowOvrDAlarmOut, EmrgOvrDAlarmOut, HtgOvrDAlarmOut, FanOvrDAlarmOut, FrostAlarmOut, IAQAlarmOut, InvalidSpAlarmOut and SpaceTempAlarmOut):

Application alarm group 1. 0 for inactive alarm, 1 for active alarm.

AV\_AlarmH: If an alarm condition is detected, the corresponding alarm is reported to a supervisory node via AV\_AlarmH. AV\_AlarmH reports only one alarm or return to normal at a time. Each alarm condition is issued only once. AV\_AlarmH is sent over the BACnet network using acknowledged service to assure that a supervisory node will receive the alarm. This NV is intended to be bound to a supervisory node that logs alarm conditions.

AV\_AlarmStatus: contains a list of all the current alarms currently detected by the device. Each alarm is stored in a bit. The alarms are the same as reported by AV\_AlarmH. This NV is intended to be used by a Management Tool to poll the AV\_AlarmStatus output for all of the current alarms.

### Disabling Alarm Reporting

Alarm reporting via AlarmStatus can be inhibited on an individual error basis via the parameter file section AlarmInhibit objects that map into that file section. This file section specifies a set of 248 bits. Each bit has a corresponding bit in Error\_Detail. If the bit in AlarmInhibit is 1, then the corresponding bit in AlarmStatus will be NOT be set, regardless of the state of the corresponding Error\_Detail bit. If the bit in AlarmInhibit is 0, then the Error\_Detail bit will propagate to AlarmStatus. Error will always report errors, regardless of AlarmInhibit. Therefore, the status LED will continue to show the status of Error. Thus it is possible no alarms are reported on AlarmStatus or AlarmH, but the LED is blinking rapidly indicating an error.

### Suppressing Specific Alarms

Reporting of specific alarms can be suppressed by using "AV\_AlarmInh0, AV\_AlarmInh1, ...AV\_AlarmInh15." This provides 1 bit for every type of error that is reported by the controller. If the bit in AV\_AlarmInh0, AV\_AlarmInh1, AV\_AlarmInh2 ...AV\_AlarmInh15 is 1, then the corresponding bit in AV\_AlarmStatus will be NOT be set. If the bit in AV\_AlarmInh0, AV\_AlarmInh1, AV\_AlarmInh2 ...AV\_AlarmInh15 is 0, then AV\_Error0, AV\_Error1, AV\_Error2, AV\_Error3...AV\_Error15 bit will propagate to AV\_AlarmStatus. Errors will be propagated up to AV\_AlarmStatus only if the Alarm is not inhibited through AV\_AlarmInh0, AV\_AlarmInh1, AV\_AlarmInh2...AV\_AlarmInh15. AV\_Error0, AV\_Error1, AV\_Error2, AV\_Error3... AV\_Error15 will always report errors. Therefore, the status LED will continue to show the status of AV\_Error0, AV\_Error1, AV\_Error2, AV\_Error3... AV\_Error15. Thus, it is possible no alarms are reported on AV\_AlarmStatus or AV\_AlarmH, but the LED is blinking rapidly indicating an error on AV\_Error0, AV\_Error1, AV\_Error2, AV\_Error3... AV\_Error15.

**Table 15: Mapping of Error conditions to Alarm IDs**

Error Description	Alarm ID reported via AV_AlarmH.type	Bit position in AV_AlarmStatus
On board Pressure sensor Failure (UI0) Sensor connected to UI1 has failed Sensor connected to UI2 has failed Sensor connected to UI3 has failed Sensor connected to UI4 has failed	1 (Sensor Failure Alarm)	0
Failed to receive DischargeAirTempIn Failed to receive TodEventCurrStateIn (AV-1215) Failed to receive TodEventNextStateIn (AV-1216) Failed to receive TodEventTimeToNextStateIn (AV-1217) Failed to receive FanStateIn (AV-1183) Failed to receive FanValueIn (AV-1184) Failed to receive ApplicModelIn (AV-1471) Failed to receive ByPassIn (AV-1473) Failed to receive SpaceTempIn (AV-1213) Failed to receive SupplyTempIn (AV-1214) Failed to receive SpaceHumIn (AV-1212) Failed to receive SpaceCO2In (AV-1211) Failed to receive FlowTrackIn (AV-1289) Failed to receive OccCmdIn (AV-1199) Failed to receive OdTempIn (AV-1200) Failed to receive SetpointIn (AV-1210) Failed to receive Free1ModIn (AV-1291) Failed to receive (ModeShareIn, ReheatStgsShareIn, ReheatCmdIn, TempFlowCmdIn, EffectOccln, PeriphStgIn and PeriphCmdIn) Failed to receive WindowIn (AV-1218) Failed to receive DLCSHedIn (AV-1474) Failed to receive FlowOffsetIn (AV-1185) Failed to receive Free1DigIn (AV-1190)	2 (BACnet network communication Error. Failed to receive update for a bound object)	1
Sylk bus error: A sylk device is not responding or there is an unexpected Sylk device on the network	5	4
Node Disabled	7	6
Invalid SetPoint Frost (Space low temperature error) Emergency Override is active Flow Override is active Periph Or Reheat Override is active Fan Override is active	4 (Application alarm. See LowFlowAlarmOut, AirFlowOvrAlarmOut, EmrgOvrAlarmOut, HtgOvrAlarmOut, FanOvrAlarmOut, FrostAlarmOut,	3

Error Description	Alarm ID reported via AV_AlarmH.type	Bit position in AV_AlarmStatus
OccSpaceTempAlarm	IAQAlarmOut, InvalidSpAlarmOut, SpaceTempAlarmOut for more details)	
Iaq Alarm		
Low Airflow error		
Failed to received data from Sylk device (TR 71/ 75 temperature)	6 (Sylk bus communication alarm)	5
Failed to received data from Sylk device (TR 71/ 75 Humidity)		
Failed to received data from Sylk device (C7400 temperature)		
Failed to received data from Sylk device (C7400 Humidity)		

	<b>Note:</b>
<p><i>AV_Error0, AV_Error1, AV_Error2, AV_Error3... AV_Error15 and AV_AlarmInh0, AV_AlarmInh1, AV_AlarmInh2... AV_AlarmInh15 are implemented as arrays of bytes. Each bit refers to a specific error and is identified by the bit position. For example, Bit position 20 means the 4th bit in the 3<sup>rd</sup> byte of the array. Similar bit position 0 means the first bit of the first byte.</i></p> <p><i>To communicate successfully with an AscVAV device, TR71/TR75 devices must be configured with the address 1 and the C7400S sensor must be configured with the address 8.</i></p>	

## Fault Handling in the Controller

### Fault Tolerance

The controller handles specific error conditions as described below:

**Table 16: Fault Tolerance**

Error Condition	Alarm	Control Action
Space Temp Error	SensorFailed	Temperature control is turned off and the damper is set to either a minimum Position or closed depending on the EffectOcc, Mode, and FlowControlType. Fan operation is not affected.  (ModeShareIn, ReheatStgsShareIn, ReheatCmdIn, TempFlowCmdIn, EffectOccln, PeriphStgIn and PeriphCmdIn) can be used as a fall back strategy for a Wall Module space temperature sensor failure. FlowControlType must be normal. When the space temperature sensor fails, the master VAV controller will take over control of the satellite VAV (controller with failed space temperature sensor).
SetPt Error	SensorFailed	Uses default occupied Set Points
Dischg Temp Error	SensorFailed	None
Supply Temp Error	SensorFailed	Supply temperature is taken out of the Mode arbitration logic.
airflow Error	SensorFailed	When the mode is Cool, the damper is modulated between 15% and 60%. When the mode is ReHeat, the damper is set to a calculated value. FlowTrackOut = 0 + FlowTrackIn
SpaceTempIn Error	CommFailed	BACnet Object is set to the FD value
ApplicModelIn Error	CommFailed	BACnet Object is set to the FD value
SetpointIn Error	CommFailed	BACnet Object is set to the FD value
WindowIn Error	CommFailed	BACnet Object is set to the FD value
SupplyTempIn Error	CommFailed	BACnet Object is set to the FD value
DLCShedIn Error	CommFailed	BACnet Object is set to the FD value
TodEventCurrStateIn Error	CommFailed	BACnet Object is set to the FD value
TodEventNextStateIn Error	CommFailed	BACnet Object is set to the FD value
TodEventTimeToNextStateIn Error	CommFailed	BACnet Object is set to the FD value
ByPassIn Error	CommFailed	BACnet Object is set to the FD value
OccCmdIn Error	CommFailed	BACnet Object is set to the FD value
FlowTrackIn Error	CommFailed	BACnet Object is set to the FD value FlowTrackOut = measuredAirflow + 0
FlowOffsetIn Error	CommFailed	BACnet Object is set to the FD value
Free1DigIn Error	CommFailed	BACnet Object is set to the FD value
Free1ModIn Error	CommFailed	BACnet Object is set to the FD value



## BACnet Objects

This section lists all the BACnet objects available in the controller.

### Configurable Inputs

Table 17: Local Input Configuration

Object Name	Object Type/ID	Data Type	Default Val	Units
CfgUI1	AV-1379	AV	13	Local Universal Input Configuration
				Universal input type 0: 20 Kntc (UI_20Kntc) 1: TR2x 20Kntc (UI_TR2xSensor) 2: TR2x SetPt Absolute (UI_TR2xSetPtAbs) 3: TR2x SetPt Relative (UI_TR2xSetPtRel) 4: RH 0 to 10 vdc (UI_RH_0_10vdc) 5: RH 2 to 10 vdc (UI_RH_2_10vdc) 6: CO <sub>2</sub> 0 to 2000 ppm (UI_CO <sub>2</sub> ) 7: Press 0 to 5 inWc (UI_Press5inWc) 8: Press 0 to 2.5 inWc (UI_Press2_5inWc) 9: Press 0 to 0.25 inWc (UI_PressQtrInWc) 10: Voltage Sensor 0 to 10 vdc (UI_Volt) 11: Custom Sensor 1 (UI_Custom1) 12: Custom Sensor 2 (UI_Custom2) 13: Digital Normally Open (UI_DI_NO) 14: Digital Normally Closed (UI_DI_NC)
CfgUI2	AV-1380	AV	13	Local Universal Input Configuration
				Universal input type 0: 20 Kntc (UI_20Kntc) 1: TR2x 20Kntc (UI_TR2xSensor) 2: TR2x SetPt Absolute (UI_TR2xSetPtAbs) 3: TR2x SetPt Relative (UI_TR2xSetPtRel) 4: RH 0 to 10 vdc (UI_RH_0_10vdc) 5: RH 2 to 10 vdc (UI_RH_2_10vdc) 6: CO <sub>2</sub> 0 to 2000 ppm (UI_CO <sub>2</sub> ) 7: Press 0 to 5 inWc (UI_Press5inWc) 8: Press 0 to 2.5 inWc (UI_Press2_5inWc) 9: Press 0 to 0.25 inWc (UI_PressQtrInWc) 10: Voltage Sensor 0 to 10 vdc (UI_Volt) 11: Custom Sensor 1 (UI_Custom1) 12: Custom Sensor 2 (UI_Custom2) 13: Digital Normally Open (UI_DI_NO) 14: Digital Normally Closed (UI_DI_NC)
CfgUI3	AV-1381	AV	13	Local Universal Input Configuration

Object Name	Object Type/ID	Data Type	Default Val	Units
				Universal input type 0: 20 Kntc (UI_20Kntc) 1: TR2x 20Kntc (UI_TR2xSensor) 2: TR2x SetPt Absolute (UI_TR2xSetPtAbs) 3: TR2x SetPt Relative (UI_TR2xSetPtRel) 4: RH 0 to 10 vdc (UI_RH_0_10vdc) 5: RH 2 to 10 vdc (UI_RH_2_10vdc) 6: CO <sub>2</sub> 0 to 2000 ppm (ULCO <sub>2</sub> ) 7: Press 0 to 5 inWc (UI_Press5inWc) 8: Press 0 to 2.5 inWc (UI_Press2_5inWc) 9: Press 0 to 0.25 inWc (UI_PressQtrInWc) 10: Voltage Sensor 0 to 10 vdc (UI_Volt) 11: Custom Sensor 1 (UI_Custom1) 12: Custom Sensor 2 (UI_Custom2) 13: Digital Normally Open (UI_DI_NO) 14: Digital Normally Closed (UI_DI_NC)
CfgUI4	AV-1382	AV	13	Local Universal Input Configuration
				Universal input type 0: 20 Kntc (UI_20Kntc) 1: TR2x 20Kntc (UI_TR2xSensor) 2: TR2x SetPt Absolute (UI_TR2xSetPtAbs) 3: TR2x SetPt Relative (UI_TR2xSetPtRel) 4: RH 0 to 10 vdc (UI_RH_0_10vdc) 5: RH 2 to 10 vdc (UI_RH_2_10vdc) 6: CO <sub>2</sub> 0 to 2000 ppm (ULCO <sub>2</sub> ) 7: Press 0 to 5 inWc (UI_Press5inWc) 8: Press 0 to 2.5 inWc (UI_Press2_5inWc) 9: Press 0 to 0.25 inWc (UI_PressQtrInWc) 10: Voltage Sensor 0 to 10 vdc (UI_Volt) 11: Custom Sensor 1 (UI_Custom1) 12: Custom Sensor 2 (UI_Custom2) 13: Digital Normally Open (UI_DI_NO) 14: Digital Normally Closed (UI_DI_NC)
CustomSensor1 Configuration				
CfgCustomSensor1Type	AV-1388	AV	1	Sensor type 0:voltage 1:resistive 255:unconfigured
CfgCustomSensor1LowVal	AV-1389	AV	0	Sensor reference low limit value in output counts. If the 'output count' falls below this value, the controller will report an INVALID value for the sensor.
CfgCustomSensor1HighVal	AV-1390	AV	0	Sensor reference high limit value in output counts. If the 'output count' falls above this value, the controller will report an INVALID value for the sensor.
CfgCustomSensor1ToolUnits	AV-1391	AV	0	Tool unit identifier. This is an enumeration identifying the units

Object Name	Object Type/ID	Data Type	Default Val	Units
				associated with the custom sensor analog input. For external tool use only. It is of no interest to the controller.
CfgCustomSensor1UserUnitLow	AV-1392	AV	0	Sensor reference low value in user selected engineering units that corresponds to an output count of 10.
CfgCustomSensor1UserUnitHigh	AV-1393	AV	0	Sensor reference high value in user selected engineering units that corresponds to an output count of 65510.
Custom Sensor #1 Configuration Input Counts				
CfgCustomSensor1In1	AV-1394	AV	0	Data point 1 input counts.
CfgCustomSensor1In2	AV-1395	AV	0	
CfgCustomSensor1In3	AV-1396	AV	0	
CfgCustomSensor1In4	AV-1397	AV	0	
CfgCustomSensor1In5	AV-1398	AV	0	
CfgCustomSensor1In6	AV-1399	AV	0	
CfgCustomSensor1In7	AV-1400	AV	0	
CfgCustomSensor1In8	AV-1401	AV	0	
CfgCustomSensor1In9	AV-1402	AV	0	
CfgCustomSensor1In10	AV-1403	AV	0	
CfgCustomSensor1In11	AV-1404	AV	0	
CfgCustomSensor1In12	AV-1405	AV	0	
Custom Sensor #1 Configuration Output Counts				
CfgCustomSensor1Out1	AV-1406	AV	0	Data point 1 output counts.
CfgCustomSensor1Out2	AV-1407	AV	0	
CfgCustomSensor1Out3	AV-1408	AV	0	
CfgCustomSensor1Out4	AV-1409	AV	0	
CfgCustomSensor1Out5	AV-1410	AV	0	
CfgCustomSensor1Out6	AV-1411	AV	0	
CfgCustomSensor1Out7	AV-1412	AV	0	
CfgCustomSensor1Out8	AV-1413	AV	0	
CfgCustomSensor1Out9	AV-1414	AV	0	
CfgCustomSensor1Out10	AV-1415	AV	0	
CfgCustomSensor1Out11	AV-1416	AV	0	
CfgCustomSensor1Out12	AV-1417	AV	0	
Custom Sensor #2 Configuration				
CfgCustomSensor2Type	AV-1344	AV	0	Sensor type 0: voltage 1: resistive 255: unconfigured
CfgCustomSensor2LowVal	AV-1345	AV	0	Sensor reference low limit value in output counts. If the 'output count' falls below this value, the controller will report an INVALID value for the sensor.
CfgCustomSensor2HighVal	AV-1346	AV	0	Sensor reference high limit value in output counts. If the 'output count' falls above this value, the controller will report an INVALID value for the sensor.

STRYKER VAV CONTROLLER

Object Name	Object Type/ID	Data Type	Default Val	Units		
CfgCustomSensor2ToolUnits	AV-1347	AV	0	Tool unit identifier. This is an enumeration identifying the units associated with the custom sensor analog input. For external tool use only. It is of no interest to the controller.		
CfgCustomSensor2UserUnitLow	AV-1348	AV	0	Sensor reference low value in user selected engineering units that corresponds to an output count of 10.		
CfgCustomSensor2UserUnitHigh	AV-1349	AV	0	Sensor reference high value in user selected engineering units that corresponds to an output count of 65510.		
Custom Sensor #2 Configuration Input Counts						
CfgCustomSensor2In1	AV-1350	AV	0	Data point 1 input counts.		
CfgCustomSensor2In2	AV-1351	AV	0			
CfgCustomSensor2In3	AV-1352	AV	0			
CfgCustomSensor2In4	AV-1353	AV	0			
CfgCustomSensor2In5	AV-1354	AV	0			
CfgCustomSensor2In6	AV-1355	AV	0			
CfgCustomSensor2In7	AV-1356	AV	0			
CfgCustomSensor2In8	AV-1357	AV	0			
CfgCustomSensor2In9	AV-1358	AV	0			
CfgCustomSensor2In10	AV-1359	AV	0			
CfgCustomSensor2In11	AV-1360	AV	0			
CfgCustomSensor2In12	AV-1361	AV	0			
Custom Sensor #2 Configuration Output Counts						
CfgCustomSensor2Out1	AV-1362	AV	0	Data point 1 output counts.		
CfgCustomSensor2Out2	AV-1363	AV	0			
CfgCustomSensor2Out3	AV-1364	AV	0			
CfgCustomSensor2Out4	AV-1365	AV	0			
CfgCustomSensor2Out5	AV-1366	AV	0			
CfgCustomSensor2Out6	AV-1367	AV	0			
CfgCustomSensor2Out7	AV-1368	AV	0			
CfgCustomSensor2Out8	AV-1369	AV	0			
CfgCustomSensor2Out9	AV-1370	AV	0			
CfgCustomSensor2Out10	AV-1371	AV	0			
CfgCustomSensor2Out11	AV-1372	AV	0			
CfgCustomSensor2Out12	AV-1373	AV	0			
Sbus Sensor Configuration						
CfgSBusSnsrC7400Disable	AV-1383	AV	1	<p>Disable Sbus sensor C7400s temp &amp; RH                      0: sensor enabled                      1: sensor disabled</p> <p>Notes:                      The C7400S sensor address must be programmed as Sbus address 8.</p> <table border="1" style="width: 100%; border-collapse: collapse;"> <tr> <td style="text-align: center;"><b>Sbus Address</b></td> <td style="text-align: center;"><b>C7400S1000 DIP Switch</b></td> </tr> </table>	<b>Sbus Address</b>	<b>C7400S1000 DIP Switch</b>
<b>Sbus Address</b>	<b>C7400S1000 DIP Switch</b>					

Object Name	Object Type/ID	Data Type	Default Val	Units			
					1	2	3
				8	OFF	OFF	OFF
CfgSBusSnsrTempOffset	AV-1433	AV	0	C7400s temperature sensor calibration offset. Offset value is added to the raw sensor value.			
CfgSBusSnsrRhOffset	AV-1434	AV	0	C7400s humidity sensor calibration offset. Offset value is added to the raw sensor value.			

Logical Inputs Enumeration Table

Table 18: Logical Inputs Enumeration

Ordinal	Nickname
0	UI_1
1	UI_2
2	UI_3
3	UI_4
4	DI_1
5	DLCShedIn
6	CfgLogicalOutVAVHtgStg1
7	CfgLogicalOutVAVHtgStg2
8	CfgLogicalOutVAVHtgStg3
9	PerphHtgStg1
10	DisableClg
11	DisableHtg
12	FanOnOut
13	FrzProtection
14	MonDigIn
15	Free1DigIn
16	VavEffectiveOcc
17	ScheduledOcc
18	SpaceTempIn
19	C7400sTemp
20	ZioTempOut
21	SpaceHumIn
22	C7400sHum
23	ZioHum
24	SpaceCO2In
25	ZioCntrSP

Ordinal	Nickname
26	SupplyTempIn
27	OnBrdPress
28	OdTempIn
29	DischargeAirTempIn
30	CfgLogicalInVAVSpcTemp
31	CfgLogicalInVAVSpcRH
32	CfgLogicalInVAVSpc CO <sub>2</sub>
33	CfgLogicalInVAVSplyTemp
34	CfgLogicalInVAVDschrgAirTemp
35	CfgLogicalInVAVVelFlowPress
36	Free1ModIn
37	CfgLogicalInVAVOdTemp
38	VavHtgSP
39	VavClgSP
40	WallModCntrSP
41	Airflow
42	DmprPos
43	CfgLogicalOutVAVReheatMod
44	CfgLogicalOutVAVPrphHtgMod
45	CfgLogicalOutVAVFanMod
46	TeminalLoad
47	AcLp1PID
48	AcLp2PID
49	AcLp1Reset
50	AcLp2Reset
255	Undefined

Logical Input Configuration

Table 19: Logical Inputs Enumeration

Object Name	Object Type/ID	Net Data Type	Default Val	Description																														
Accessory loop logical input configuration																																		
CfgLogicalInAcc1Sensor	AV-1445	AV	255	<p>control loop 1 sensor Application Units: unrestricted analog value 0 ≤ range ≤ 255</p> <table border="1"> <tr><td>0</td><td>UI_1outLive</td></tr> <tr><td>1</td><td>UI_2outLive</td></tr> <tr><td>2</td><td>UI_3outLive</td></tr> <tr><td>3</td><td>UI_4outLive</td></tr> <tr><td>19</td><td>C7400sTempYSnapshot</td></tr> <tr><td>22</td><td>C7400sRHYSnapshot</td></tr> <tr><td>30</td><td>SpcTempLogicalEFF_OUTPUTSnapshot</td></tr> <tr><td>31</td><td>SpcRHLogicalEFF_OUTPUTSnapshot</td></tr> <tr><td>32</td><td>SpcCO2LogicalEFF_OUTPUTSnapshot</td></tr> <tr><td>33</td><td>SplyTempLogicalEFF_OUTUTSnapshot</td></tr> <tr><td>34</td><td>DatLogicalEFF_OUTPUTSnapshot</td></tr> <tr><td>35</td><td>FlowPressCalOUTPUTSnapshot</td></tr> <tr><td>36</td><td>Free1ModIn_levPercentoutSnapshot</td></tr> <tr><td>37</td><td>OdTempLogicalEFF_OUTPUTSnapshot</td></tr> <tr><td>255</td><td>Undefined</td></tr> </table>	0	UI_1outLive	1	UI_2outLive	2	UI_3outLive	3	UI_4outLive	19	C7400sTempYSnapshot	22	C7400sRHYSnapshot	30	SpcTempLogicalEFF_OUTPUTSnapshot	31	SpcRHLogicalEFF_OUTPUTSnapshot	32	SpcCO2LogicalEFF_OUTPUTSnapshot	33	SplyTempLogicalEFF_OUTUTSnapshot	34	DatLogicalEFF_OUTPUTSnapshot	35	FlowPressCalOUTPUTSnapshot	36	Free1ModIn_levPercentoutSnapshot	37	OdTempLogicalEFF_OUTPUTSnapshot	255	Undefined
0	UI_1outLive																																	
1	UI_2outLive																																	
2	UI_3outLive																																	
3	UI_4outLive																																	
19	C7400sTempYSnapshot																																	
22	C7400sRHYSnapshot																																	
30	SpcTempLogicalEFF_OUTPUTSnapshot																																	
31	SpcRHLogicalEFF_OUTPUTSnapshot																																	
32	SpcCO2LogicalEFF_OUTPUTSnapshot																																	
33	SplyTempLogicalEFF_OUTUTSnapshot																																	
34	DatLogicalEFF_OUTPUTSnapshot																																	
35	FlowPressCalOUTPUTSnapshot																																	
36	Free1ModIn_levPercentoutSnapshot																																	
37	OdTempLogicalEFF_OUTPUTSnapshot																																	
255	Undefined																																	
CfgLogicalInAcc1Setpoint	AV-1446	AV	255	<p>Control loop 1 setpoint. If this input is a valid value then it overrides the (CfgAcc1SetPtsOcc, CfgAcc1SetPtsStdby, CfgAcc1SetPtsUnOcc, CfgAcc1SetPtsMinResetSnsrVal, CfgAcc1SetPtsOccMaxResetSnsrVal, CfgAcc1SetPtsOccMinResetAmnt and CfgAcc1SetPtsOccMaxResetAmnt). Application Units: Same units as selected sensor 0 ≤ range ≤ 255</p> <table border="1"> <tr><td>0</td><td>UI_1outLive</td></tr> <tr><td>1</td><td>UI_2outLive</td></tr> <tr><td>2</td><td>UI_3outLive</td></tr> <tr><td>3</td><td>UI_4outLive</td></tr> <tr><td>36</td><td>Free1ModIn_levPercentoutSnapshot</td></tr> <tr><td>38</td><td>HtgSPOUTPUTSnapshot</td></tr> <tr><td>39</td><td>CfgSPYSnapshot</td></tr> <tr><td>40</td><td>WallModCntrSPYSnapshot</td></tr> <tr><td>255</td><td>Undefined</td></tr> </table>	0	UI_1outLive	1	UI_2outLive	2	UI_3outLive	3	UI_4outLive	36	Free1ModIn_levPercentoutSnapshot	38	HtgSPOUTPUTSnapshot	39	CfgSPYSnapshot	40	WallModCntrSPYSnapshot	255	Undefined												
0	UI_1outLive																																	
1	UI_2outLive																																	
2	UI_3outLive																																	
3	UI_4outLive																																	
36	Free1ModIn_levPercentoutSnapshot																																	
38	HtgSPOUTPUTSnapshot																																	
39	CfgSPYSnapshot																																	
40	WallModCntrSPYSnapshot																																	
255	Undefined																																	

STRYKER VAV CONTROLLER

Object Name	Object Type/ID	Net Data Type	Default Val	Description																																												
CfgLogicalInAcc1Reset	AV-1447	AV	255	control loop 1 reset sensor Application Units: unrestricted analog value 0 ≤ range ≤ 255																																												
				<table border="1"> <tr><td>0</td><td>UI_1outLive</td></tr> <tr><td>1</td><td>UI_2outLive</td></tr> <tr><td>2</td><td>UI_3outLive</td></tr> <tr><td>3</td><td>UI_4outLive</td></tr> <tr><td>19</td><td>C7400sTempYSnapshot</td></tr> <tr><td>22</td><td>C7400sRHYSnapshot</td></tr> <tr><td>30</td><td>SpcTempLogicalEFF_OUTPUTSnapshot</td></tr> <tr><td>31</td><td>SpcRHLogicalEFF_OUTPUTSnapshot</td></tr> <tr><td>32</td><td>SpcCO2LogicalEFF_OUTPUTSnapshot</td></tr> <tr><td>33</td><td>SplyTempLogicalEFF_OUTUTSnapshot</td></tr> <tr><td>34</td><td>DatLogicalEFF_OUTPUTSnapshot</td></tr> <tr><td>35</td><td>FlowPressCalOUTPUTSnapshot</td></tr> <tr><td>36</td><td>Free1ModIn_levPercentoutSnapshot</td></tr> <tr><td>37</td><td>OdTempLogicalEFF_OUTPUTSnapshot</td></tr> <tr><td>40</td><td>WallModCntrSPYSnapshot</td></tr> <tr><td>41</td><td>AirFlowOUTPUTSnapshot</td></tr> <tr><td>42</td><td>DmprPosApproxOUTPUTSnapshot</td></tr> <tr><td>43</td><td>ReheatModOUTPUTSnapshot</td></tr> <tr><td>44</td><td>PeriphHtgModEFF_OUTPUTSnapshot</td></tr> <tr><td>45</td><td>FanModEFF_OUTPUTSnapshot</td></tr> <tr><td>46</td><td>TerminalLoadYSnapshot</td></tr> <tr><td>255</td><td>Undefined</td></tr> </table>	0	UI_1outLive	1	UI_2outLive	2	UI_3outLive	3	UI_4outLive	19	C7400sTempYSnapshot	22	C7400sRHYSnapshot	30	SpcTempLogicalEFF_OUTPUTSnapshot	31	SpcRHLogicalEFF_OUTPUTSnapshot	32	SpcCO2LogicalEFF_OUTPUTSnapshot	33	SplyTempLogicalEFF_OUTUTSnapshot	34	DatLogicalEFF_OUTPUTSnapshot	35	FlowPressCalOUTPUTSnapshot	36	Free1ModIn_levPercentoutSnapshot	37	OdTempLogicalEFF_OUTPUTSnapshot	40	WallModCntrSPYSnapshot	41	AirFlowOUTPUTSnapshot	42	DmprPosApproxOUTPUTSnapshot	43	ReheatModOUTPUTSnapshot	44	PeriphHtgModEFF_OUTPUTSnapshot	45	FanModEFF_OUTPUTSnapshot	46	TerminalLoadYSnapshot	255	Undefined
				0	UI_1outLive																																											
				1	UI_2outLive																																											
				2	UI_3outLive																																											
				3	UI_4outLive																																											
				19	C7400sTempYSnapshot																																											
				22	C7400sRHYSnapshot																																											
				30	SpcTempLogicalEFF_OUTPUTSnapshot																																											
				31	SpcRHLogicalEFF_OUTPUTSnapshot																																											
				32	SpcCO2LogicalEFF_OUTPUTSnapshot																																											
				33	SplyTempLogicalEFF_OUTUTSnapshot																																											
				34	DatLogicalEFF_OUTPUTSnapshot																																											
				35	FlowPressCalOUTPUTSnapshot																																											
				36	Free1ModIn_levPercentoutSnapshot																																											
				37	OdTempLogicalEFF_OUTPUTSnapshot																																											
				40	WallModCntrSPYSnapshot																																											
				41	AirFlowOUTPUTSnapshot																																											
				42	DmprPosApproxOUTPUTSnapshot																																											
				43	ReheatModOUTPUTSnapshot																																											
				44	PeriphHtgModEFF_OUTPUTSnapshot																																											
				45	FanModEFF_OUTPUTSnapshot																																											
				46	TerminalLoadYSnapshot																																											
				255	Undefined																																											



Object Name	Object Type/ID	Net Data Type	Default Val	Description																																
CfgLogicalInAcc1Disable	AV-1422	AV	255	<p>control loop 1 disable signal Application Units: Binary Value 0 ≤ range ≤ 255</p> <table border="1" data-bbox="935 386 1490 989"> <tr><td>0</td><td>UI_1outLive</td></tr> <tr><td>1</td><td>UI_2outLive</td></tr> <tr><td>2</td><td>UI_3outLive</td></tr> <tr><td>3</td><td>UI_4outLive</td></tr> <tr><td>5</td><td>DLCShedIn_stateoutSnapshot</td></tr> <tr><td>6</td><td>HtgStg1OUTPUTSsnapshot</td></tr> <tr><td>7</td><td>RHStageDriverSTAGE2Snapshot</td></tr> <tr><td>8</td><td>RHStageDriverTAGE3Snapshot</td></tr> <tr><td>9</td><td>PerphHtgSTAGE1Snapshot</td></tr> <tr><td>10</td><td>Disable_Clg_TChgOUTPUTSsnapshot</td></tr> <tr><td>11</td><td>Disable_Htg_TChgOUTPUTSsnapshot</td></tr> <tr><td>12</td><td>FanOnEFF_OUTPUTSsnapshot</td></tr> <tr><td>13</td><td>FrzPrtctOUTPUTSsnapshot</td></tr> <tr><td>14</td><td>MonDigInOUTPUTSsnapshot</td></tr> <tr><td>15</td><td>Free1DigOUTPUTSsnapshot</td></tr> <tr><td>255</td><td>Undefined</td></tr> </table>	0	UI_1outLive	1	UI_2outLive	2	UI_3outLive	3	UI_4outLive	5	DLCShedIn_stateoutSnapshot	6	HtgStg1OUTPUTSsnapshot	7	RHStageDriverSTAGE2Snapshot	8	RHStageDriverTAGE3Snapshot	9	PerphHtgSTAGE1Snapshot	10	Disable_Clg_TChgOUTPUTSsnapshot	11	Disable_Htg_TChgOUTPUTSsnapshot	12	FanOnEFF_OUTPUTSsnapshot	13	FrzPrtctOUTPUTSsnapshot	14	MonDigInOUTPUTSsnapshot	15	Free1DigOUTPUTSsnapshot	255	Undefined
0	UI_1outLive																																			
1	UI_2outLive																																			
2	UI_3outLive																																			
3	UI_4outLive																																			
5	DLCShedIn_stateoutSnapshot																																			
6	HtgStg1OUTPUTSsnapshot																																			
7	RHStageDriverSTAGE2Snapshot																																			
8	RHStageDriverTAGE3Snapshot																																			
9	PerphHtgSTAGE1Snapshot																																			
10	Disable_Clg_TChgOUTPUTSsnapshot																																			
11	Disable_Htg_TChgOUTPUTSsnapshot																																			
12	FanOnEFF_OUTPUTSsnapshot																																			
13	FrzPrtctOUTPUTSsnapshot																																			
14	MonDigInOUTPUTSsnapshot																																			
15	Free1DigOUTPUTSsnapshot																																			
255	Undefined																																			
CfgLogicalInAcc1Occ	AV-1424	AV	255	<p>control loop 1 occupancy status input Application Units: Binary Value or Occupancy Enumeration (0 – 255) 0 ≤ range ≤ 255</p> <table border="1" data-bbox="935 1108 1490 1375"> <tr><td>0</td><td>UI_1outLive</td></tr> <tr><td>1</td><td>UI_2outLive</td></tr> <tr><td>2</td><td>UI_3outLive</td></tr> <tr><td>3</td><td>UI_4outLive</td></tr> <tr><td>16</td><td>EffOccEFF_OUTPUTSsnapshot</td></tr> <tr><td>17</td><td>SchedOccOUTPUTSsnapshot</td></tr> <tr><td>255</td><td>Undefined</td></tr> </table>	0	UI_1outLive	1	UI_2outLive	2	UI_3outLive	3	UI_4outLive	16	EffOccEFF_OUTPUTSsnapshot	17	SchedOccOUTPUTSsnapshot	255	Undefined																		
0	UI_1outLive																																			
1	UI_2outLive																																			
2	UI_3outLive																																			
3	UI_4outLive																																			
16	EffOccEFF_OUTPUTSsnapshot																																			
17	SchedOccOUTPUTSsnapshot																																			
255	Undefined																																			

Object Name	Object Type/ID	Net Data Type	Default Val	Description																														
CfgLogicalInAcc2Sensor	AV-1448	AV	255	<p>control loop 2 sensor Application Units: unrestricted analog value <math>0 \leq \text{range} \leq 255</math></p> <table border="1" data-bbox="831 432 1385 1066"> <tr><td>0</td><td>UI_1outLive</td></tr> <tr><td>1</td><td>UI_2outLive</td></tr> <tr><td>2</td><td>UI_3outLive</td></tr> <tr><td>3</td><td>UI_4outLive</td></tr> <tr><td>19</td><td>C7400sTempYSnapshot</td></tr> <tr><td>22</td><td>C7400sRHYSnapshot</td></tr> <tr><td>30</td><td>SpcTempLogicalEFF_OUTPUTSnapshot</td></tr> <tr><td>31</td><td>SpcRHLogicalEFF_OUTPUTSnapshot</td></tr> <tr><td>32</td><td>SpcCO2LogicalEFF_OUTPUTSnapshot</td></tr> <tr><td>33</td><td>SplyTempLogicalEFF_OUTUTSnapshot</td></tr> <tr><td>34</td><td>DatLogicalEFF_OUTPUTSnapshot</td></tr> <tr><td>35</td><td>FlowPressCalOUTPUTSnapshot</td></tr> <tr><td>36</td><td>Free1ModIn_levPercentoutSnapshot</td></tr> <tr><td>37</td><td>OdTempLogicalEFF_OUTPUTSnapshot</td></tr> <tr><td>255</td><td>Undefined</td></tr> </table>	0	UI_1outLive	1	UI_2outLive	2	UI_3outLive	3	UI_4outLive	19	C7400sTempYSnapshot	22	C7400sRHYSnapshot	30	SpcTempLogicalEFF_OUTPUTSnapshot	31	SpcRHLogicalEFF_OUTPUTSnapshot	32	SpcCO2LogicalEFF_OUTPUTSnapshot	33	SplyTempLogicalEFF_OUTUTSnapshot	34	DatLogicalEFF_OUTPUTSnapshot	35	FlowPressCalOUTPUTSnapshot	36	Free1ModIn_levPercentoutSnapshot	37	OdTempLogicalEFF_OUTPUTSnapshot	255	Undefined
0	UI_1outLive																																	
1	UI_2outLive																																	
2	UI_3outLive																																	
3	UI_4outLive																																	
19	C7400sTempYSnapshot																																	
22	C7400sRHYSnapshot																																	
30	SpcTempLogicalEFF_OUTPUTSnapshot																																	
31	SpcRHLogicalEFF_OUTPUTSnapshot																																	
32	SpcCO2LogicalEFF_OUTPUTSnapshot																																	
33	SplyTempLogicalEFF_OUTUTSnapshot																																	
34	DatLogicalEFF_OUTPUTSnapshot																																	
35	FlowPressCalOUTPUTSnapshot																																	
36	Free1ModIn_levPercentoutSnapshot																																	
37	OdTempLogicalEFF_OUTPUTSnapshot																																	
255	Undefined																																	
CfgLogicalInAcc2Setpoint	AV-1449	AV	255	<p>Control loop 2 setpoint. If this input is a valid value then it overrides the (CfgAcc2SetPtsOcc, CfgAcc2SetPtsStdby, CfgAcc2SetPtsUnOcc, CfgAcc2SetPtsMinResetSnsrVal, CfgAcc2SetPtsOccMaxResetSnsrVal, CfgAcc2SetPtsOccMinResetAmnt and CfgAcc2SetPtsOccMaxResetAmnt). Application Units: Same units as selected sensor <math>0 \leq \text{range} \leq 255</math></p> <table border="1" data-bbox="831 1341 1385 1705"> <tr><td>0</td><td>UI_1outLive</td></tr> <tr><td>1</td><td>UI_2outLive</td></tr> <tr><td>2</td><td>UI_3outLive</td></tr> <tr><td>3</td><td>UI_4outLive</td></tr> <tr><td>36</td><td>Free1ModIn_levPercentoutSnapshot</td></tr> <tr><td>38</td><td>HtgSPOUTPUTSnapshot</td></tr> <tr><td>39</td><td>ClgSPYSnapshot</td></tr> <tr><td>40</td><td>WallModCntrSPYSnapshot</td></tr> <tr><td>255</td><td>Undefined</td></tr> </table>	0	UI_1outLive	1	UI_2outLive	2	UI_3outLive	3	UI_4outLive	36	Free1ModIn_levPercentoutSnapshot	38	HtgSPOUTPUTSnapshot	39	ClgSPYSnapshot	40	WallModCntrSPYSnapshot	255	Undefined												
0	UI_1outLive																																	
1	UI_2outLive																																	
2	UI_3outLive																																	
3	UI_4outLive																																	
36	Free1ModIn_levPercentoutSnapshot																																	
38	HtgSPOUTPUTSnapshot																																	
39	ClgSPYSnapshot																																	
40	WallModCntrSPYSnapshot																																	
255	Undefined																																	

Object Name	Object Type/ID	Net Data Type	Default Val	Description	
CfgLogicalInAcc2Reset	AV-1450	AV	255	Control loop 2 reset sensor Application Units: unrestricted analog value $0 \leq \text{range} \leq 255$	
				0	UI_1outLive
				1	UI_2outLive
				2	UI_3outLive
				3	UI_4outLive
				19	C7400sTempYSnapshot
				22	C7400sRHYSnapshot
				30	SpcTempLogicalEFF_OUTPUTSnapshot
				31	SpcRHLogicalEFF_OUTPUTSnapshot
				32	SpcCO2LogicalEFF_OUTPUTSnapshot
				33	SplyTempLogicalEFF_OUTPUTSnapshot
				34	DatLogicalEFF_OUTPUTSnapshot
				35	FlowPressCalOUTPUTSnapshot
				36	Free1ModIn_levPercentoutSnapshot
				37	OdTempLogicalEFF_OUTPUTSnapshot
				40	WallModCntrSPYSnapshot
				41	AirFlowOUTPUTSnapshot
				42	DmprPosApproxOUTPUTSnapshot
				43	ReheatModOUTPUTSnapshot
				44	PeriphHtgModEFF_OUTPUTSnapshot
				45	FanModEFF_OUTPUTSnapshot
				46	TerminalLoadYSnapshot
				255	Undefined

Object Name	Object Type/ID	Net Data Type	Default Val	Description																																
CfgLogicalInAcc2Disable	AV-1423	AV	255	Control loop 2 disable signal Application Units: Binary Value 0 ≤ range ≤ 255 <table border="1"> <tr><td>0</td><td>UI_1outLive</td></tr> <tr><td>1</td><td>UI_2outLive</td></tr> <tr><td>2</td><td>UI_3outLive</td></tr> <tr><td>3</td><td>UI_4outLive</td></tr> <tr><td>5</td><td>DlcShedIn_stateoutSnapshot</td></tr> <tr><td>6</td><td>HtgStg1OUTPUTSnapshot</td></tr> <tr><td>7</td><td>RHStageDriverSTAGE2Snapshot</td></tr> <tr><td>8</td><td>RHStageDriverTAGE3Snapshot</td></tr> <tr><td>9</td><td>PerphHtgSTAGE1Snapshot</td></tr> <tr><td>10</td><td>Disable_Clg_TChgOUTPUTSnapshot</td></tr> <tr><td>11</td><td>Disable_Htg_TChgOUTPUTSnapshot</td></tr> <tr><td>12</td><td>FanOnEFF_OUTPUTSnapshot</td></tr> <tr><td>13</td><td>FrzPrtctOUTPUTSnapshot</td></tr> <tr><td>14</td><td>MonDigInOUTPUTSnapshot</td></tr> <tr><td>15</td><td>Free1DigOUTPUTSnapshot</td></tr> <tr><td>255</td><td>Undefined</td></tr> </table>	0	UI_1outLive	1	UI_2outLive	2	UI_3outLive	3	UI_4outLive	5	DlcShedIn_stateoutSnapshot	6	HtgStg1OUTPUTSnapshot	7	RHStageDriverSTAGE2Snapshot	8	RHStageDriverTAGE3Snapshot	9	PerphHtgSTAGE1Snapshot	10	Disable_Clg_TChgOUTPUTSnapshot	11	Disable_Htg_TChgOUTPUTSnapshot	12	FanOnEFF_OUTPUTSnapshot	13	FrzPrtctOUTPUTSnapshot	14	MonDigInOUTPUTSnapshot	15	Free1DigOUTPUTSnapshot	255	Undefined
0	UI_1outLive																																			
1	UI_2outLive																																			
2	UI_3outLive																																			
3	UI_4outLive																																			
5	DlcShedIn_stateoutSnapshot																																			
6	HtgStg1OUTPUTSnapshot																																			
7	RHStageDriverSTAGE2Snapshot																																			
8	RHStageDriverTAGE3Snapshot																																			
9	PerphHtgSTAGE1Snapshot																																			
10	Disable_Clg_TChgOUTPUTSnapshot																																			
11	Disable_Htg_TChgOUTPUTSnapshot																																			
12	FanOnEFF_OUTPUTSnapshot																																			
13	FrzPrtctOUTPUTSnapshot																																			
14	MonDigInOUTPUTSnapshot																																			
15	Free1DigOUTPUTSnapshot																																			
255	Undefined																																			
CfgLogicalInAcc2Occ	AV-1425	AV	255	Control loop 2 occupancy status input. Application Units: Binary Value or Occupancy Enumeration (0 – 255) 0 ≤ range ≤ 255 <table border="1"> <tr><td>0</td><td>UI_1outLive</td></tr> <tr><td>1</td><td>UI_2outLive</td></tr> <tr><td>2</td><td>UI_3outLive</td></tr> <tr><td>3</td><td>UI_4outLive</td></tr> <tr><td>16</td><td>EffOccEFF_OUTPUTSnapshot</td></tr> <tr><td>17</td><td>SchedOccOUTPUTSnapshot</td></tr> <tr><td>255</td><td>Undefined</td></tr> </table>	0	UI_1outLive	1	UI_2outLive	2	UI_3outLive	3	UI_4outLive	16	EffOccEFF_OUTPUTSnapshot	17	SchedOccOUTPUTSnapshot	255	Undefined																		
0	UI_1outLive																																			
1	UI_2outLive																																			
2	UI_3outLive																																			
3	UI_4outLive																																			
16	EffOccEFF_OUTPUTSnapshot																																			
17	SchedOccOUTPUTSnapshot																																			
255	Undefined																																			
VAV Control Logical Input configuration																																				
CfgLogicalInVAVSpcTemp	AV-1435	AV	20	Space temperature Application Units: F 0 ≤ range ≤ 255 <table border="1"> <tr><td>0</td><td>UI_1outLive</td></tr> <tr><td>1</td><td>UI_2outLive</td></tr> <tr><td>2</td><td>UI_3outLive</td></tr> <tr><td>3</td><td>UI_4outLive</td></tr> <tr><td>18</td><td>SpaceTempIn_tempPoutSnapshot</td></tr> <tr><td>20</td><td>ZioTempYSnapshot</td></tr> <tr><td>255</td><td>Undefined</td></tr> </table>	0	UI_1outLive	1	UI_2outLive	2	UI_3outLive	3	UI_4outLive	18	SpaceTempIn_tempPoutSnapshot	20	ZioTempYSnapshot	255	Undefined																		
0	UI_1outLive																																			
1	UI_2outLive																																			
2	UI_3outLive																																			
3	UI_4outLive																																			
18	SpaceTempIn_tempPoutSnapshot																																			
20	ZioTempYSnapshot																																			
255	Undefined																																			

Object Name	Object Type/ID	Net Data Type	Default Val	Description																
CfgLogicalInVAVSpcRH	AV-1436	AV	255	Space humidity Application Units: percent 0 ≤ range ≤ 255 <table border="1"> <tr><td>0</td><td>UI_1outLive</td></tr> <tr><td>1</td><td>UI_2outLive</td></tr> <tr><td>2</td><td>UI_3outLive</td></tr> <tr><td>3</td><td>UI_4outLive</td></tr> <tr><td>21</td><td>CfgLogicalInVAVSpcRH</td></tr> <tr><td>22</td><td>C7400sRHYSnapshot</td></tr> <tr><td>23</td><td>ZioRHYSnapshot</td></tr> <tr><td>255</td><td>Undefined</td></tr> </table>	0	UI_1outLive	1	UI_2outLive	2	UI_3outLive	3	UI_4outLive	21	CfgLogicalInVAVSpcRH	22	C7400sRHYSnapshot	23	ZioRHYSnapshot	255	Undefined
0	UI_1outLive																			
1	UI_2outLive																			
2	UI_3outLive																			
3	UI_4outLive																			
21	CfgLogicalInVAVSpcRH																			
22	C7400sRHYSnapshot																			
23	ZioRHYSnapshot																			
255	Undefined																			
CfgLogicalInVAVSpcCO2	AV-1437	AV	255	Space CO <sub>2</sub> value Application Units: ppm 0 ≤ range ≤ 255 <table border="1"> <tr><td>0</td><td>UI_1outLive</td></tr> <tr><td>1</td><td>UI_2outLive</td></tr> <tr><td>2</td><td>UI_3outLive</td></tr> <tr><td>3</td><td>UI_4outLive</td></tr> <tr><td>24</td><td>SpaceCO2In_ppmoutSnapshot</td></tr> <tr><td>255</td><td>Undefined</td></tr> </table>	0	UI_1outLive	1	UI_2outLive	2	UI_3outLive	3	UI_4outLive	24	SpaceCO2In_ppmoutSnapshot	255	Undefined				
0	UI_1outLive																			
1	UI_2outLive																			
2	UI_3outLive																			
3	UI_4outLive																			
24	SpaceCO2In_ppmoutSnapshot																			
255	Undefined																			
CfgLogicalInVAVSpcTempSP	AV-1438	AV	255	Space temperature setpoint value. Application Units: F or ΔF 0 ≤ range ≤ 255 <table border="1"> <tr><td>0</td><td>UI_1outLive</td></tr> <tr><td>1</td><td>UI_2outLive</td></tr> <tr><td>2</td><td>UI_3outLive</td></tr> <tr><td>3</td><td>UI_4outLive</td></tr> <tr><td>25</td><td>ZioCntrSP</td></tr> <tr><td>255</td><td>Undefined</td></tr> </table>	0	UI_1outLive	1	UI_2outLive	2	UI_3outLive	3	UI_4outLive	25	ZioCntrSP	255	Undefined				
0	UI_1outLive																			
1	UI_2outLive																			
2	UI_3outLive																			
3	UI_4outLive																			
25	ZioCntrSP																			
255	Undefined																			
CfgLogicalInVAVDschrgAirTemp	AV-1444	AV	255	VAV zone terminal discharge air temperature value. Application Units: F 0 ≤ range ≤ 255 Default: Undefined <table border="1"> <tr><td>0</td><td>UI_1outLive</td></tr> <tr><td>1</td><td>UI_2outLive</td></tr> <tr><td>2</td><td>UI_3outLive</td></tr> <tr><td>3</td><td>UI_4outLive</td></tr> <tr><td>19</td><td>C7400sTempYSnapshot</td></tr> <tr><td>29</td><td>DischargeAirTempln_tempPoutSnapshot</td></tr> <tr><td>255</td><td>Undefined</td></tr> </table>	0	UI_1outLive	1	UI_2outLive	2	UI_3outLive	3	UI_4outLive	19	C7400sTempYSnapshot	29	DischargeAirTempln_tempPoutSnapshot	255	Undefined		
0	UI_1outLive																			
1	UI_2outLive																			
2	UI_3outLive																			
3	UI_4outLive																			
19	C7400sTempYSnapshot																			
29	DischargeAirTempln_tempPoutSnapshot																			
255	Undefined																			

STRYKER VAV CONTROLLER

Object Name	Object Type/ID	Net Data Type	Default Val	Description														
CfgLogicalInVAVSplyTemp	AV-1439	AV	26	<p>Supply air temperature value to the VAV zone terminal Application Units: F  <math>0 \leq \text{range} \leq 255</math></p> <table border="1"> <tr><td>0</td><td>UI_1outLive</td></tr> <tr><td>1</td><td>UI_2outLive</td></tr> <tr><td>2</td><td>UI_3outLive</td></tr> <tr><td>3</td><td>UI_4outLive</td></tr> <tr><td>19</td><td>C7400sTempYSnapshot</td></tr> <tr><td>26</td><td>SupplyTempIn_tempPoutSnapshot</td></tr> <tr><td>255</td><td>Undefined</td></tr> </table>	0	UI_1outLive	1	UI_2outLive	2	UI_3outLive	3	UI_4outLive	19	C7400sTempYSnapshot	26	SupplyTempIn_tempPoutSnapshot	255	Undefined
0	UI_1outLive																	
1	UI_2outLive																	
2	UI_3outLive																	
3	UI_4outLive																	
19	C7400sTempYSnapshot																	
26	SupplyTempIn_tempPoutSnapshot																	
255	Undefined																	
CfgLogicalInVAVOdTemp	AV-1441	AV	255	<p>Outdoor air temperature value Application Units: F  <math>0 \leq \text{range} \leq 255</math></p> <table border="1"> <tr><td>0</td><td>UI_1outLive</td></tr> <tr><td>1</td><td>UI_2outLive</td></tr> <tr><td>2</td><td>UI_3outLive</td></tr> <tr><td>3</td><td>UI_4outLive</td></tr> <tr><td>19</td><td>C7400sTempYSnapshot</td></tr> <tr><td>28</td><td>OdTempIn_tempPoutSnapshot</td></tr> <tr><td>255</td><td>Undefined</td></tr> </table>	0	UI_1outLive	1	UI_2outLive	2	UI_3outLive	3	UI_4outLive	19	C7400sTempYSnapshot	28	OdTempIn_tempPoutSnapshot	255	Undefined
0	UI_1outLive																	
1	UI_2outLive																	
2	UI_3outLive																	
3	UI_4outLive																	
19	C7400sTempYSnapshot																	
28	OdTempIn_tempPoutSnapshot																	
255	Undefined																	
CfgLogicalInVAVOdRh	AV-1442	AV	255	<p>Outdoor humidity value.                      Application Units: percent <math>0 \leq \text{range} \leq 255</math></p> <table border="1"> <tr><td>0</td><td>UI_1outLive</td></tr> <tr><td>1</td><td>UI_2outLive</td></tr> <tr><td>2</td><td>UI_3outLive</td></tr> <tr><td>3</td><td>UI_4outLive</td></tr> <tr><td>22</td><td>C7400sRHYSnapshot</td></tr> <tr><td>255</td><td>Undefined</td></tr> </table>	0	UI_1outLive	1	UI_2outLive	2	UI_3outLive	3	UI_4outLive	22	C7400sRHYSnapshot	255	Undefined		
0	UI_1outLive																	
1	UI_2outLive																	
2	UI_3outLive																	
3	UI_4outLive																	
22	C7400sRHYSnapshot																	
255	Undefined																	
CfgLogicalInVAVVelFlowPres	AV-1470	AV	27	<p>Airflow velocity pressure value.                      Application Units: pressure inWc                      Default: OnBrdPress</p> <table border="1"> <tr><td>0</td><td>UI_1outLive</td></tr> <tr><td>1</td><td>UI_2outLive</td></tr> <tr><td>2</td><td>UI_3outLive</td></tr> <tr><td>3</td><td>UI_4outLive</td></tr> <tr><td>27</td><td>PressOnBrdoutLive</td></tr> <tr><td>255</td><td>Undefined</td></tr> </table>	0	UI_1outLive	1	UI_2outLive	2	UI_3outLive	3	UI_4outLive	27	PressOnBrdoutLive	255	Undefined		
0	UI_1outLive																	
1	UI_2outLive																	
2	UI_3outLive																	
3	UI_4outLive																	
27	PressOnBrdoutLive																	
255	Undefined																	

Object Name	Object Type/ID	Net Data Type	Default Val	Description																				
CfgLogicalInVAVStaticPress	AV-1443	AV	255	<p>Static pressure value. Connected to the BACnet object StatisPressOut. Typically used to monitor duct or building static pressure.</p> <p>Application Units: pressure inWc 0 ≤ range ≤ 255</p> <table border="1"> <tr><td>0</td><td>UI_1outLive</td></tr> <tr><td>1</td><td>UI_2outLive</td></tr> <tr><td>2</td><td>UI_3outLive</td></tr> <tr><td>3</td><td>UI_4outLive</td></tr> <tr><td>27</td><td>PressOnBrdoutLive</td></tr> <tr><td>255</td><td>Undefined</td></tr> </table>	0	UI_1outLive	1	UI_2outLive	2	UI_3outLive	3	UI_4outLive	27	PressOnBrdoutLive	255	Undefined								
0	UI_1outLive																							
1	UI_2outLive																							
2	UI_3outLive																							
3	UI_4outLive																							
27	PressOnBrdoutLive																							
255	Undefined																							
CfgLogicalInVAVMonitorSnsr	AV-1440	AV	255	<p>Monitor sensor value. Connected to the BACnet object MonSensorOut.</p> <p>Application Units: Unrestricted 0 ≤ range ≤ 255</p> <table border="1"> <tr><td>0</td><td>UI_1outLive</td></tr> <tr><td>1</td><td>UI_2outLive</td></tr> <tr><td>2</td><td>UI_3outLive</td></tr> <tr><td>3</td><td>UI_4outLive</td></tr> <tr><td>19</td><td>C7400sTempYSnapshot</td></tr> <tr><td>20</td><td>ZioTempYSnapshot</td></tr> <tr><td>22</td><td>C7400sRHYSnapshot</td></tr> <tr><td>23</td><td>ZioRHYSnapshot</td></tr> <tr><td>27</td><td>PressOnBrdoutLive</td></tr> <tr><td>255</td><td>Undefined</td></tr> </table>	0	UI_1outLive	1	UI_2outLive	2	UI_3outLive	3	UI_4outLive	19	C7400sTempYSnapshot	20	ZioTempYSnapshot	22	C7400sRHYSnapshot	23	ZioRHYSnapshot	27	PressOnBrdoutLive	255	Undefined
0	UI_1outLive																							
1	UI_2outLive																							
2	UI_3outLive																							
3	UI_4outLive																							
19	C7400sTempYSnapshot																							
20	ZioTempYSnapshot																							
22	C7400sRHYSnapshot																							
23	ZioRHYSnapshot																							
27	PressOnBrdoutLive																							
255	Undefined																							
CfgLogicalInVAVMonitorSwitch	AV-1429	AV	255	<p>Monitor switch value. Connected to the BACnet object MonSwOut</p> <p>Application Units: Binary Value 0 ≤ range ≤ 255</p> <table border="1"> <tr><td>0</td><td>UI_1outLive</td></tr> <tr><td>1</td><td>UI_2outLive</td></tr> <tr><td>2</td><td>UI_3outLive</td></tr> <tr><td>3</td><td>UI_4outLive</td></tr> <tr><td>255</td><td>Undefined</td></tr> </table>	0	UI_1outLive	1	UI_2outLive	2	UI_3outLive	3	UI_4outLive	255	Undefined										
0	UI_1outLive																							
1	UI_2outLive																							
2	UI_3outLive																							
3	UI_4outLive																							
255	Undefined																							
CfgLogicalInVAVOccSensor	AV-1426	AV	255	<p>Occupancy sensor.</p> <p>Application Units: Binary Value or Occupancy Enumeration (0 – 255) 0 ≤ range ≤ 255</p> <table border="1"> <tr><td>0</td><td>UI_1outLive</td></tr> <tr><td>1</td><td>UI_2outLive</td></tr> <tr><td>2</td><td>UI_3outLive</td></tr> <tr><td>3</td><td>UI_4outLive</td></tr> <tr><td>255</td><td>Undefined</td></tr> </table>	0	UI_1outLive	1	UI_2outLive	2	UI_3outLive	3	UI_4outLive	255	Undefined										
0	UI_1outLive																							
1	UI_2outLive																							
2	UI_3outLive																							
3	UI_4outLive																							
255	Undefined																							

Object Name	Object Type/ID	Net Data Type	Default Val	Description																								
CfgLogicalInVAVWindowOpen	AV-1427	AV	255	<p>Window open sensor.</p> <p>Application Units: Binary Value <math>0 \leq \text{range} \leq 255</math></p> <table border="1"> <tr><td>0</td><td>UI_1outLive</td></tr> <tr><td>1</td><td>UI_2outLive</td></tr> <tr><td>2</td><td>UI_3outLive</td></tr> <tr><td>3</td><td>UI_4outLive</td></tr> <tr><td>255</td><td>Undefined</td></tr> </table>	0	UI_1outLive	1	UI_2outLive	2	UI_3outLive	3	UI_4outLive	255	Undefined														
0	UI_1outLive																											
1	UI_2outLive																											
2	UI_3outLive																											
3	UI_4outLive																											
255	Undefined																											
CfgLogicalInVAVHtgClgChgOvr	AV-1428	AV	255	<p>Heating changeover switch. Typically used to determine if warm heating air is supplied to the zone terminal.</p> <p>1: Heating warm air supplied to terminal 0: Cooling, cold air supplied to terminal</p> <p>Application Units: Binary Value <math>0 \leq \text{range} \leq 255</math></p> <table border="1"> <tr><td>0</td><td>UI_1outLive</td></tr> <tr><td>1</td><td>UI_2outLive</td></tr> <tr><td>2</td><td>UI_3outLive</td></tr> <tr><td>3</td><td>UI_4outLive</td></tr> <tr><td>255</td><td>Undefined</td></tr> </table>	0	UI_1outLive	1	UI_2outLive	2	UI_3outLive	3	UI_4outLive	255	Undefined														
0	UI_1outLive																											
1	UI_2outLive																											
2	UI_3outLive																											
3	UI_4outLive																											
255	Undefined																											
CfgLogicalInVAVWallModOvrBut	AV-1430	AV	255	<p>Wall module occupancy override button. Typically used with the conventional wall module. Must be connected to UI1 on Stryker BACnet VAV controller.</p> <p>Application Units: Binary Value <math>0 \leq \text{range} \leq 255</math></p> <table border="1"> <tr><td>4</td><td>DI_1outLive</td></tr> <tr><td>255</td><td>Undefined</td></tr> </table> <p>Notes: If 4 (DI_1) is selected, UI_1 is inactive and cannot be assigned to another logical input. Override Type = Normal</p> <table border="1"> <thead> <tr> <th>Override Button Held Down</th> <th>LED</th> <th>WM Override</th> <th>Comment</th> </tr> </thead> <tbody> <tr> <td>0.2 to 1.1 second</td> <td>OFF</td> <td>OCC NUL</td> <td>No Override (cancel)</td> </tr> <tr> <td>1.2 to 4 second</td> <td>ON</td> <td>BYPASS</td> <td>Timed Occupied Override Timer (re)loaded whenever the button is pressed for this duration. WM Override is set to OCCNUL when timer expires.</td> </tr> <tr> <td>4.1 to 7 second</td> <td>1 flash/sec</td> <td>UNOCC</td> <td>Unoccupied Override</td> </tr> <tr> <td>Longer than 7.1 second</td> <td>OFF</td> <td>OCC NUL</td> <td>No Override (cancel)</td> </tr> </tbody> </table>	4	DI_1outLive	255	Undefined	Override Button Held Down	LED	WM Override	Comment	0.2 to 1.1 second	OFF	OCC NUL	No Override (cancel)	1.2 to 4 second	ON	BYPASS	Timed Occupied Override Timer (re)loaded whenever the button is pressed for this duration. WM Override is set to OCCNUL when timer expires.	4.1 to 7 second	1 flash/sec	UNOCC	Unoccupied Override	Longer than 7.1 second	OFF	OCC NUL	No Override (cancel)
4	DI_1outLive																											
255	Undefined																											
Override Button Held Down	LED	WM Override	Comment																									
0.2 to 1.1 second	OFF	OCC NUL	No Override (cancel)																									
1.2 to 4 second	ON	BYPASS	Timed Occupied Override Timer (re)loaded whenever the button is pressed for this duration. WM Override is set to OCCNUL when timer expires.																									
4.1 to 7 second	1 flash/sec	UNOCC	Unoccupied Override																									
Longer than 7.1 second	OFF	OCC NUL	No Override (cancel)																									



Object Name	Object Type/ID	Net Data Type	Default Val	Description																				
				<p>Override Type = Bypass Only</p> <table border="1" data-bbox="935 390 1481 1129"> <thead> <tr> <th data-bbox="935 390 1060 541">Override Button Held Down</th> <th data-bbox="1063 390 1141 541">LED</th> <th data-bbox="1144 390 1268 541">WM Override</th> <th data-bbox="1271 390 1481 541">Comment</th> </tr> </thead> <tbody> <tr> <td data-bbox="935 546 1060 640">0.2 to 1.1 second</td> <td data-bbox="1063 546 1141 640">OFF</td> <td data-bbox="1144 546 1268 640">OCCNUL</td> <td data-bbox="1271 546 1481 640">No Override (cancel)</td> </tr> <tr> <td data-bbox="935 644 1060 961">1.2 to 4 second</td> <td data-bbox="1063 644 1141 961">ON</td> <td data-bbox="1144 644 1268 961">BYPASS</td> <td data-bbox="1271 644 1481 961">Timed Occupied Override Timer (re)loaded whenever the button is pressed for this duration. WM Override is set to OCCNUL when timer expires.</td> </tr> <tr> <td data-bbox="935 966 1060 1033">4.1 to 7 second</td> <td data-bbox="1063 966 1141 1033">OFF</td> <td data-bbox="1144 966 1268 1033">OCCNUL</td> <td data-bbox="1271 966 1481 1033">No Override (cancel)</td> </tr> <tr> <td data-bbox="935 1037 1060 1129">Longer than 7.1 second</td> <td data-bbox="1063 1037 1141 1129">OFF</td> <td data-bbox="1144 1037 1268 1129">OCCNUL</td> <td data-bbox="1271 1037 1481 1129">No Override (cancel)</td> </tr> </tbody> </table>	Override Button Held Down	LED	WM Override	Comment	0.2 to 1.1 second	OFF	OCCNUL	No Override (cancel)	1.2 to 4 second	ON	BYPASS	Timed Occupied Override Timer (re)loaded whenever the button is pressed for this duration. WM Override is set to OCCNUL when timer expires.	4.1 to 7 second	OFF	OCCNUL	No Override (cancel)	Longer than 7.1 second	OFF	OCCNUL	No Override (cancel)
Override Button Held Down	LED	WM Override	Comment																					
0.2 to 1.1 second	OFF	OCCNUL	No Override (cancel)																					
1.2 to 4 second	ON	BYPASS	Timed Occupied Override Timer (re)loaded whenever the button is pressed for this duration. WM Override is set to OCCNUL when timer expires.																					
4.1 to 7 second	OFF	OCCNUL	No Override (cancel)																					
Longer than 7.1 second	OFF	OCCNUL	No Override (cancel)																					
CfgLogicalInVAVPeriphHtgMin	AV-1451	AV	255	<p>Peripheral heating valve minimum position. Typically used to connect an accessory loop reset schedule.  <math>0 \leq \text{range} \leq 255</math></p> <table border="1" data-bbox="935 1264 1490 1507"> <tbody> <tr> <td data-bbox="935 1264 1013 1306">36</td> <td data-bbox="1016 1264 1490 1306">Free1ModIn_levPercentoutSnapshot</td> </tr> <tr> <td data-bbox="935 1310 1013 1352">47</td> <td data-bbox="1016 1310 1490 1352">AccPid1OUTPUTSnapshot</td> </tr> <tr> <td data-bbox="935 1356 1013 1398">48</td> <td data-bbox="1016 1356 1490 1398">AccPid2OUTPUTSnapshot</td> </tr> <tr> <td data-bbox="935 1402 1013 1444">49</td> <td data-bbox="1016 1402 1490 1444">Acc1ResetEFF_OUTPUTSnapshot</td> </tr> <tr> <td data-bbox="935 1449 1013 1491">50</td> <td data-bbox="1016 1449 1490 1491">Acc2ResetEFF_OUTPUTSnapshot</td> </tr> <tr> <td data-bbox="935 1495 1013 1507">255</td> <td data-bbox="1016 1495 1490 1507">Undefined</td> </tr> </tbody> </table>	36	Free1ModIn_levPercentoutSnapshot	47	AccPid1OUTPUTSnapshot	48	AccPid2OUTPUTSnapshot	49	Acc1ResetEFF_OUTPUTSnapshot	50	Acc2ResetEFF_OUTPUTSnapshot	255	Undefined								
36	Free1ModIn_levPercentoutSnapshot																							
47	AccPid1OUTPUTSnapshot																							
48	AccPid2OUTPUTSnapshot																							
49	Acc1ResetEFF_OUTPUTSnapshot																							
50	Acc2ResetEFF_OUTPUTSnapshot																							
255	Undefined																							

Table 20: Local Output Configuration

Object Name	Object Type/ID	Net Data Type	Default Val	Description
Configure local analog output				
CfgAO1AnalogRange	AV-1219	AV	0	Analog range selection 0: 0 to 10 vdc (AO_0_10vdcDir) 1: 10 to 0 vdc (AO_0_10vdcRev) 2: 2 to 10 vdc (AO_2_10vdcDir) 3: 10 to 2 vdc (AO_2_10vdcRev) 4: 0 to 20 mA (AO_0_20maDir) 5: 20 to 0 mA (AO_0_20maRev) 6: 0 to 22 mA (AO_0_22maDir) 7: 22 to 0 mA (AO_0_22maRev) 8: 4 to 20 mA (AO_4_20maDir) 9: 20 to 4 mA (AO_4_20maRev) 10: Binary output (AO_Binary)
Configure local analog output				
CfgAO2AnalogRange	AV-1220	AV	0	Analog range selection 0: 0 to 10 vdc (AO_0_10vdcDir) 1: 10 to 0 vdc (AO_0_10vdcRev) 2: 2 to 10 vdc (AO_2_10vdcDir) 3: 10 to 2 vdc (AO_2_10vdcRev) 4: 0 to 20 mA (AO_0_20maDir) 5: 20 to 0 mA (AO_0_20maRev) 6: 0 to 22 mA (AO_0_22maDir) 7: 22 to 0 mA (AO_0_22maRev) 8: 4 to 20 mA (AO_4_20maDir) 9: 20 to 4 mA (AO_4_20maRev) 10: Binary output (AO_Binary)
Configure local digital output				
CfgDO1Type	AV-1272	AV	0	Digital output type 0: Binary output 1: Pulse width modulating output
CfgDO1PWMPeriod	AV-1273	AV	25.6	PWM period in seconds $1 \leq \text{range} \leq 3276.7 \text{ sec}$ Precision: 1 (data entry in seconds)
CfgDO1PWMZero	AV-1274	AV	0.1	PWM zero time in seconds $1 \leq \text{range} \leq 3276.7 \text{ sec}$ Precision: 1 (data entry in seconds)
CfgDO1PWMFull	AV-1275	AV	25.5	PWM full time in seconds $1 \leq \text{range} \leq 3276.7 \text{ sec}$ Precision: 1 (data entry in seconds)
Configure local digital output				
CfgDO2Type	AV-1276	AV	0	Digital output type 0: Binary output 1: Pulse width modulating output
CfgDO2PWMPeriod	AV-1277	AV	25.6	PWM period in seconds $1 \leq \text{range} \leq 3276.7 \text{ sec}$
CfgDO2PWMZero	AV-1278	AV	0.1	PWM zero time in tenths of seconds $1 \leq \text{range} \leq 3276.7 \text{ sec}$
CfgDO2PWMFull	AV-1279	AV	25.5	PWM full time in seconds $1 \leq \text{range} \leq 3276.7 \text{ sec}$
Configure local digital output				
CfgDO3Type	AV-1280	AV	0	Digital output type 0: Binary output 1: Pulse width modulating output
CfgDO3PWMPeriod	AV-1281	AV	25.6	PWM period in tenths of seconds $1 \leq \text{range} \leq 3276.7 \text{ sec}$
CfgDO3PWMZero	AV-1282	AV	0.1	PWM zero time in seconds $1 \leq \text{range} \leq 3276.7 \text{ sec}$

Object Name	Object Type/ID	Net Data Type	Default Val	Description
CfgDO3PWMSFull	AV-1283	AV	25.5	PWM full time in seconds 1 ≤ range ≤ 3276.7 sec
Configure local digital output				
CfgDO4Type	AV-1284	AV	0	Digital output type 0: Binary output 1: Pulse width modulating output
CfgDO4PWMPeriod	AV-1285	AV	25.6	PWM period in seconds 1 ≤ range ≤ 3276.7 sec
CfgDO4PWMZero	AV-1286	AV	0.1	PWM zero time in seconds 1 ≤ range ≤ 3276.7 sec
CfgDO4PWMSFull	AV-1287	AV	25.5	PWM full time in seconds 1 ≤ range ≤ 3276.7 sec Precision: 0
Configure floating output Pin1 = DO3 (DO must be configured binary, nciDO3.type = 0) Pin2 = DO4 (DO must be configured binary, nciDO4.type = 0) Note: To free up binary outputs DO3 & DO4, set the travelTime = 0				
CfgFloat1Action	AV-1291	AV	0	Reverse action 0: False 100%=full open, 0% = full closed 1: True 100%=full closed, 0% = full open
CfgFloat1TravelTime	AV-1292	AV	90	Motor travel time 0 ≤ range ≤ 3276.7 sec Precision: 1 Notes: Set the travel time to zero to disable the Floating Output and free up DO3 & DO4
CfgFloat1AutoSync	AV-1293	AV	0	Auto Sync Type 0: none 1: Sync closed 2: Sync open Refer to Appendix E – Floating Actuator Auto Sync
CfgFloat1SyncIntvl	AV-1294	AV	24	Auto sync interval 0 ≤ range ≤ 254 hours Precision: 1
CfgFloat1PwrUpSync	AV-1295	AV	0	Power up Sync Type 0: none 1: Sync closed 2: Sync open Refer to Appendix E – Floating Actuator Auto Sync
CfgFloat1PwrUpDelay	AV-1296	AV	0	Actuator Power up delay. 0 ≤ range ≤ 3276.7 sec Precision: 1
CfgFloat1UnOccSync	AV-1297	AV	0	Sync the floating actuator on an occupancy transition to unoccupied. 0: none 1: Sync closed 2: Sync open
CfgFloat1NviSync	AV-1298	AV	0	Sync the floating actuator on an active Free1.DigIn signal. 0: none 1: Sync closed 2: Sync open
Configure floating output Pin1 = DO1 (DO must be configured binary, nciDO1.type = 0) Pin2 = DO2 (DO must be configured binary, nciDO2.type = 0) Note: To free up binary outputs DO1 & DO2, set the travelTime = 0.				

Object Name	Object Type/ID	Net Data Type	Default Val	Description
CfgFloat2Action	AV-1298	AV	0	Reverse action 0: False 100%=full open, 0% = full closed 1: True 100%=full closed, 0% = full open
CfgFloat2TravelTime	AV-1300	AV	0	Motor travel time 0 ≤ range ≤ 3276.7 sec Precision: 1 Notes: 1. Set the travel time to zero to disable the Floating Output and free up DO1 & DO2
CfgFloat2AutoSync	AV-1301	AV	0	Auto Sync Type 0: none 1: Sync closed 2: Sync open Refer to Appendix E – Floating Actuator Auto Sync
CfgFloat2SyncIntvl	AV-1302	AV	24	Auto sync interval 0 ≤ range ≤ 254 hours Precision: 0
CfgFloat2PwrUpSync	AV-1303	AV	0	Power up Sync Type 0: none 1: Sync closed 2: Sync open Refer to Appendix E – Floating Actuator Auto Sync
CfgFloat2PwrUpDelay	AV-1304	AV	0	Actuator Power up delay. 0 ≤ range ≤ 3276.7 sec Precision: 1
CfgFloat2UnOccSync	AV-1305	AV	0	Sync the floating actuator on an occupancy transition to unoccupied. 0: none 1: Sync closed 2: Sync open
CfgFloat2NviSync	AV-1306	AV	0	Sync the floating actuator on an active Free1DigIn signal. 0: none 1: Sync closed 2: Sync open

**Logical Outputs Enumeration Description**

**Table 21: Logical Outputs Enumeration Description**

Ordinal	Nickname	Enumeration Tag	Description
0	AO1	AO1in	Analog output #1
1	AO2	AO2in	Analog output #2
2	DO1	DO1in	Binary output #1
3	DO2	DO2in	Binary output #2
4	DO3	DO3in	Binary output #3
5	DO4	DO4in	Binary output #4
6	Float1	Float1in	Floating modulating output #1
7	Float2	Float2in	Floating modulating output #2
8	AO1Live	AO1inLive	Analog output #1 live data suitable for wall

Ordinal	Nickname	Enumeration Tag	Description
			module LED
9	AO2Live	AO2inLive	Analog output #2 live data
10	DO1inLive	DO1inLive	Binary Output #1 Live data
11	DO2inLive	DO2inLive	Binary Output #2 Live data
12	DO3inLive	DO3inLive	Binary Output #3 Live data
13	DO4inLive	DO4inLive	Binary Output #4 Live data
255	Undefined	Undefined	

**Logical Outputs Description**

**Table 22: Logical Outputs Configuration**

Object Name	Object Type/ID	Net Data Type	Default Val	Description														
Logical Accessory Loop Output Configuration																		
CfgLogicalOutAcc1Stg1	AV-1563	AV	255	Accessory Loop #1 digital output Stage #1 Output Type: Binary Default: Undefined 0 ≤range ≤255 <table border="1"> <tr><td>0</td><td>AO1in</td></tr> <tr><td>1</td><td>AO2in</td></tr> <tr><td>2</td><td>DO1in</td></tr> <tr><td>3</td><td>DO2in</td></tr> <tr><td>4</td><td>DO3in</td></tr> <tr><td>5</td><td>DO4in</td></tr> <tr><td>255</td><td>Undefined</td></tr> </table>	0	AO1in	1	AO2in	2	DO1in	3	DO2in	4	DO3in	5	DO4in	255	Undefined
0	AO1in																	
1	AO2in																	
2	DO1in																	
3	DO2in																	
4	DO3in																	
5	DO4in																	
255	Undefined																	
CfgLogicalOutAcc1Stg2	AV-1564	AV	255	Accessory Loop #1 digital output Stage #2 Output Type: Binary Default: Undefined 0 ≤range ≤255 <table border="1"> <tr><td>0</td><td>AO1in</td></tr> <tr><td>1</td><td>AO2in</td></tr> <tr><td>2</td><td>DO1in</td></tr> <tr><td>3</td><td>DO2in</td></tr> <tr><td>4</td><td>DO3in</td></tr> <tr><td>5</td><td>DO4in</td></tr> <tr><td>255</td><td>Undefined</td></tr> </table>	0	AO1in	1	AO2in	2	DO1in	3	DO2in	4	DO3in	5	DO4in	255	Undefined
0	AO1in																	
1	AO2in																	
2	DO1in																	
3	DO2in																	
4	DO3in																	
5	DO4in																	
255	Undefined																	
CfgLogicalOutAcc1Stg3	AV-1565	AV	255	Accessory Loop #1 digital output Stage #3 Output Type: Binary Default: Undefined 0 ≤range ≤255														

Object Name	Object Type/ID	Net Data Type	Default Val	Description																		
CfgLogicalOutAcc1Aux	AV-1566	AV	255	<p>Accessory Loop #1 digital output Auxiliary control. Output active with the modulating output value or staged output.</p> <p>Output Type: Binary Default: Undefined 0 ≤ range ≤255</p> <table border="1"> <tr><td>0</td><td>AO1in</td></tr> <tr><td>1</td><td>AO2in</td></tr> <tr><td>2</td><td>DO1in</td></tr> <tr><td>3</td><td>DO2in</td></tr> <tr><td>4</td><td>DO3in</td></tr> <tr><td>5</td><td>DO4in</td></tr> <tr><td>255</td><td>Undefined</td></tr> </table>	0	AO1in	1	AO2in	2	DO1in	3	DO2in	4	DO3in	5	DO4in	255	Undefined				
0	AO1in																					
1	AO2in																					
2	DO1in																					
3	DO2in																					
4	DO3in																					
5	DO4in																					
255	Undefined																					
CfgLogicalOutAcc1Mod	AV-1578	AV	255	<p>Accessory Loop #1 modulating output.</p> <p>Output Type: PWM, Float, Analog Current or Voltage Default: Undefined</p> <p>0 ≤ range ≤255</p> <table border="1"> <tr><td>0</td><td>AO1in</td></tr> <tr><td>1</td><td>AO2in</td></tr> <tr><td>2</td><td>DO1in</td></tr> <tr><td>3</td><td>DO2in</td></tr> <tr><td>4</td><td>DO3in</td></tr> <tr><td>5</td><td>DO4in</td></tr> <tr><td>6</td><td>Float1in</td></tr> <tr><td>7</td><td>Float2in</td></tr> <tr><td>255</td><td>Undefined</td></tr> </table>	0	AO1in	1	AO2in	2	DO1in	3	DO2in	4	DO3in	5	DO4in	6	Float1in	7	Float2in	255	Undefined
0	AO1in																					
1	AO2in																					
2	DO1in																					
3	DO2in																					
4	DO3in																					
5	DO4in																					
6	Float1in																					
7	Float2in																					
255	Undefined																					
CfgLogicalOutAcc2Stg1	AV-1567	AV	255	<p>Accessory Loop #2 digital output Stage #1 Output Type: Binary</p> <p>Default: Undefined 0 ≤ range ≤255</p> <table border="1"> <tr><td>0</td><td>AO1in</td></tr> <tr><td>1</td><td>AO2in</td></tr> <tr><td>2</td><td>DO1in</td></tr> <tr><td>3</td><td>DO2in</td></tr> <tr><td>4</td><td>DO3in</td></tr> <tr><td>5</td><td>DO4in</td></tr> <tr><td>255</td><td>Undefined</td></tr> </table>	0	AO1in	1	AO2in	2	DO1in	3	DO2in	4	DO3in	5	DO4in	255	Undefined				
0	AO1in																					
1	AO2in																					
2	DO1in																					
3	DO2in																					
4	DO3in																					
5	DO4in																					
255	Undefined																					

Object Name	Object Type/ID	Net Data Type	Default Val	Description														
CfgLogicalOutAcc2Stg2	AV-1570	AV	255	Accessory Loop #2 digital output Stage #2 Output Type: Binary Default: Undefined 0 ≤range ≤255 <table border="1" data-bbox="906 394 1133 678"> <tr><td>0</td><td>AO1in</td></tr> <tr><td>1</td><td>AO2in</td></tr> <tr><td>2</td><td>DO1in</td></tr> <tr><td>3</td><td>DO2in</td></tr> <tr><td>4</td><td>DO3in</td></tr> <tr><td>5</td><td>DO4in</td></tr> <tr><td>255</td><td>Undefined</td></tr> </table>	0	AO1in	1	AO2in	2	DO1in	3	DO2in	4	DO3in	5	DO4in	255	Undefined
0	AO1in																	
1	AO2in																	
2	DO1in																	
3	DO2in																	
4	DO3in																	
5	DO4in																	
255	Undefined																	
CfgLogicalOutAcc2Stg3	AV-1568	AV	255	Accessory Loop #2 digital output Stage #3 Output Type: Binary Default: Undefined 0 ≤range ≤255 <table border="1" data-bbox="906 783 1133 1066"> <tr><td>0</td><td>AO1in</td></tr> <tr><td>1</td><td>AO2in</td></tr> <tr><td>2</td><td>DO1in</td></tr> <tr><td>3</td><td>DO2in</td></tr> <tr><td>4</td><td>DO3in</td></tr> <tr><td>5</td><td>DO4in</td></tr> <tr><td>255</td><td>Undefined</td></tr> </table>	0	AO1in	1	AO2in	2	DO1in	3	DO2in	4	DO3in	5	DO4in	255	Undefined
0	AO1in																	
1	AO2in																	
2	DO1in																	
3	DO2in																	
4	DO3in																	
5	DO4in																	
255	Undefined																	
CfgLogicalOutAcc2Aux	AV-1569	AV	255	Accessory Loop #2 digital output Auxiliary control. Output active with the modulating output value or staged output. Output Type: Binary Default: Undefined 0 ≤range ≤255 <table border="1" data-bbox="906 1224 1133 1505"> <tr><td>0</td><td>AO1in</td></tr> <tr><td>1</td><td>AO2in</td></tr> <tr><td>2</td><td>DO1in</td></tr> <tr><td>3</td><td>DO2in</td></tr> <tr><td>4</td><td>DO3in</td></tr> <tr><td>5</td><td>DO4in</td></tr> <tr><td>255</td><td>Undefined</td></tr> </table>	0	AO1in	1	AO2in	2	DO1in	3	DO2in	4	DO3in	5	DO4in	255	Undefined
0	AO1in																	
1	AO2in																	
2	DO1in																	
3	DO2in																	
4	DO3in																	
5	DO4in																	
255	Undefined																	

Object Name	Object Type/ID	Net Data Type	Default Val	Description																		
CfgLogicalOutAcc2Mod	AV-1577	AV	255	<p>Accessory Loop #2 modulating output.                      Output Type: PWM, Float, Analog Current or Voltage                      Default: Undefined  <math>0 \leq \text{range} \leq 255</math></p> <table border="1"> <tr><td>0</td><td>AO1in</td></tr> <tr><td>1</td><td>AO2in</td></tr> <tr><td>2</td><td>DO1in</td></tr> <tr><td>3</td><td>DO2in</td></tr> <tr><td>4</td><td>DO3in</td></tr> <tr><td>5</td><td>DO4in</td></tr> <tr><td>6</td><td>Float1in</td></tr> <tr><td>7</td><td>Float2in</td></tr> <tr><td>255</td><td>Undefined</td></tr> </table>	0	AO1in	1	AO2in	2	DO1in	3	DO2in	4	DO3in	5	DO4in	6	Float1in	7	Float2in	255	Undefined
0	AO1in																					
1	AO2in																					
2	DO1in																					
3	DO2in																					
4	DO3in																					
5	DO4in																					
6	Float1in																					
7	Float2in																					
255	Undefined																					
Logical VAV Output Configuration																						
CfgLogicalOutVAVHtgStg 1	AV-1552	AV	255	<p>Zone terminal Heating stage 1 Output Type: Binary                      Default: DO1  <math>0 \leq \text{range} \leq 255</math></p> <table border="1"> <tr><td>0</td><td>AO1in</td></tr> <tr><td>1</td><td>AO2in</td></tr> <tr><td>2</td><td>DO1in</td></tr> <tr><td>3</td><td>DO2in</td></tr> <tr><td>4</td><td>DO3in</td></tr> <tr><td>5</td><td>DO4in</td></tr> <tr><td>255</td><td>Undefined</td></tr> </table>	0	AO1in	1	AO2in	2	DO1in	3	DO2in	4	DO3in	5	DO4in	255	Undefined				
0	AO1in																					
1	AO2in																					
2	DO1in																					
3	DO2in																					
4	DO3in																					
5	DO4in																					
255	Undefined																					
CfgLogicalOutVAVHtgStg 2	AV-1553	AV	255	<p>Zone terminal Heating stage 2 Output Type: Binary                      Default: Undefined <math>0 \leq \text{range} \leq 255</math></p> <table border="1"> <tr><td>0</td><td>AO1in</td></tr> <tr><td>1</td><td>AO2in</td></tr> <tr><td>2</td><td>DO1in</td></tr> <tr><td>3</td><td>DO2in</td></tr> <tr><td>4</td><td>DO3in</td></tr> <tr><td>5</td><td>DO4in</td></tr> <tr><td>255</td><td>Undefined</td></tr> </table>	0	AO1in	1	AO2in	2	DO1in	3	DO2in	4	DO3in	5	DO4in	255	Undefined				
0	AO1in																					
1	AO2in																					
2	DO1in																					
3	DO2in																					
4	DO3in																					
5	DO4in																					
255	Undefined																					



Object Name	Object Type/ID	Net Data Type	Default Val	Description														
CfgLogicalOutVAVHtgStg3	AV-1554	AV	255	<p>Zone terminal Heating stage 3 Output Type: Binary Default: Undefined <math>0 \leq \text{range} \leq 255</math></p> <table border="1"> <tr><td>0</td><td>AO1in</td></tr> <tr><td>1</td><td>AO2in</td></tr> <tr><td>2</td><td>DO1in</td></tr> <tr><td>3</td><td>DO2in</td></tr> <tr><td>4</td><td>DO3in</td></tr> <tr><td>5</td><td>DO4in</td></tr> <tr><td>255</td><td>Undefined</td></tr> </table>	0	AO1in	1	AO2in	2	DO1in	3	DO2in	4	DO3in	5	DO4in	255	Undefined
0	AO1in																	
1	AO2in																	
2	DO1in																	
3	DO2in																	
4	DO3in																	
5	DO4in																	
255	Undefined																	
Flt1Close_Select	AV-1579	AV	12	<p>Float 1 Close output assignment. Default: DO3 <math>0 \leq \text{range} \leq 255</math></p> <table border="1"> <tr><td>10</td><td>DO1inLive</td></tr> <tr><td>11</td><td>DO2inLive</td></tr> <tr><td>12</td><td>DO3inLive</td></tr> <tr><td>13</td><td>DO4inLive</td></tr> <tr><td>255</td><td>Undefined</td></tr> </table>	10	DO1inLive	11	DO2inLive	12	DO3inLive	13	DO4inLive	255	Undefined				
10	DO1inLive																	
11	DO2inLive																	
12	DO3inLive																	
13	DO4inLive																	
255	Undefined																	
Flt1Open_Select	AV-1580	AV	13	<p>Float 1 Open output assignment. Default: DO4 <math>0 \leq \text{range} \leq 255</math></p> <table border="1"> <tr><td>10</td><td>DO1inLive</td></tr> <tr><td>11</td><td>DO2inLive</td></tr> <tr><td>12</td><td>DO3inLive</td></tr> <tr><td>13</td><td>DO4inLive</td></tr> <tr><td>255</td><td>Undefined</td></tr> </table>	10	DO1inLive	11	DO2inLive	12	DO3inLive	13	DO4inLive	255	Undefined				
10	DO1inLive																	
11	DO2inLive																	
12	DO3inLive																	
13	DO4inLive																	
255	Undefined																	

Object Name	Object Type/ID	Net Data Type	Default Val	Description														
Flt2Close_Select	AV-1581	AV	255	Float 2 Close output assignment. Default: 255 $0 \leq \text{range} \leq 255$ <table border="1"> <tr><td>10</td><td>DO1inLive</td></tr> <tr><td>11</td><td>DO2inLive</td></tr> <tr><td>12</td><td>DO3inLive</td></tr> <tr><td>13</td><td>DO4inLive</td></tr> <tr><td>255</td><td>Undefined</td></tr> </table>	10	DO1inLive	11	DO2inLive	12	DO3inLive	13	DO4inLive	255	Undefined				
10	DO1inLive																	
11	DO2inLive																	
12	DO3inLive																	
13	DO4inLive																	
255	Undefined																	
Flt2Open_Select	AV-1582	AV	255	Float 2 Open output assignment. Default: 255 $0 \leq \text{range} \leq 255$ <table border="1"> <tr><td>10</td><td>DO1inLive</td></tr> <tr><td>11</td><td>DO2inLive</td></tr> <tr><td>12</td><td>DO3inLive</td></tr> <tr><td>13</td><td>DO4inLive</td></tr> <tr><td>255</td><td>Undefined</td></tr> </table>	10	DO1inLive	11	DO2inLive	12	DO3inLive	13	DO4inLive	255	Undefined				
10	DO1inLive																	
11	DO2inLive																	
12	DO3inLive																	
13	DO4inLive																	
255	Undefined																	
CfgLogicalOutVAVPeriphHtgStg	AV-1555	AV	255	Peripheral heat stage output Type: Binary $0 \leq \text{range} \leq 255$ <table border="1"> <tr><td>0</td><td>AO1in</td></tr> <tr><td>1</td><td>AO2in</td></tr> <tr><td>2</td><td>DO1in</td></tr> <tr><td>3</td><td>DO2in</td></tr> <tr><td>4</td><td>DO3in</td></tr> <tr><td>5</td><td>DO4in</td></tr> <tr><td>255</td><td>Undefined</td></tr> </table>	0	AO1in	1	AO2in	2	DO1in	3	DO2in	4	DO3in	5	DO4in	255	Undefined
0	AO1in																	
1	AO2in																	
2	DO1in																	
3	DO2in																	
4	DO3in																	
5	DO4in																	
255	Undefined																	
CfgLogicalOutVAVFanDig	AV-1556	AV	255	Fan start stop Output Type: Binary $0 \leq \text{range} \leq 255$ <table border="1"> <tr><td>0</td><td>AO1in</td></tr> <tr><td>1</td><td>AO2in</td></tr> <tr><td>2</td><td>DO1in</td></tr> <tr><td>3</td><td>DO2in</td></tr> <tr><td>4</td><td>DO3in</td></tr> <tr><td>5</td><td>DO4in</td></tr> <tr><td>255</td><td>Undefined</td></tr> </table>	0	AO1in	1	AO2in	2	DO1in	3	DO2in	4	DO3in	5	DO4in	255	Undefined
0	AO1in																	
1	AO2in																	
2	DO1in																	
3	DO2in																	
4	DO3in																	
5	DO4in																	
255	Undefined																	

Object Name	Object Type/ID	Net Data Type	Default Val	Description														
CfgLogicalOutVAVAuxDig	AV-1557	AV	255	<p>Auxiliary digital output. Output is active when the effective occupancy = Occupied Output Type: Binary Default: Undefined 0 ≤range ≤255</p> <table border="1"> <tr><td>0</td><td>AO1in</td></tr> <tr><td>1</td><td>AO2in</td></tr> <tr><td>2</td><td>DO1in</td></tr> <tr><td>3</td><td>DO2in</td></tr> <tr><td>4</td><td>DO3in</td></tr> <tr><td>5</td><td>DO4in</td></tr> <tr><td>255</td><td>Undefined</td></tr> </table>	0	AO1in	1	AO2in	2	DO1in	3	DO2in	4	DO3in	5	DO4in	255	Undefined
0	AO1in																	
1	AO2in																	
2	DO1in																	
3	DO2in																	
4	DO3in																	
5	DO4in																	
255	Undefined																	
CfgLogicalOutVAVAuxPlsOn	AV-1558	AV	255	<p>Auxiliary pulse ON output. Typically connected to a lighting relay. The output is pulsed when the effective occupancy changes to occupied. Output Type: Binary Default: Undefined 0 ≤range ≤255</p> <table border="1"> <tr><td>0</td><td>AO1in</td></tr> <tr><td>1</td><td>AO2in</td></tr> <tr><td>2</td><td>DO1in</td></tr> <tr><td>3</td><td>DO2in</td></tr> <tr><td>4</td><td>DO3in</td></tr> <tr><td>5</td><td>DO4in</td></tr> <tr><td>255</td><td>Undefined</td></tr> </table>	0	AO1in	1	AO2in	2	DO1in	3	DO2in	4	DO3in	5	DO4in	255	Undefined
0	AO1in																	
1	AO2in																	
2	DO1in																	
3	DO2in																	
4	DO3in																	
5	DO4in																	
255	Undefined																	
CfgLogicalOutVAVAuxPlsOff	AV-1559	AV	255	<p>Auxiliary pulse OFF output. Typically connected to a lighting relay. The output is pulsed when the effective occupancy changes not occupied. Output Type: Binary Default: Undefined 0 ≤range ≤255</p> <table border="1"> <tr><td>0</td><td>AO1in</td></tr> <tr><td>1</td><td>AO2in</td></tr> <tr><td>2</td><td>DO1in</td></tr> <tr><td>3</td><td>DO2in</td></tr> <tr><td>4</td><td>DO3in</td></tr> <tr><td>5</td><td>DO4in</td></tr> <tr><td>255</td><td>Undefined</td></tr> </table>	0	AO1in	1	AO2in	2	DO1in	3	DO2in	4	DO3in	5	DO4in	255	Undefined
0	AO1in																	
1	AO2in																	
2	DO1in																	
3	DO2in																	
4	DO3in																	
5	DO4in																	
255	Undefined																	
CfgLogicalOutVAVFreeDig1	AV-1560	AV	255	<p>Free digital output. Controlled from the network command through Free1DigIn Output Type: Binary Default: Undefined 0 ≤range ≤255</p> <table border="1"> <tr><td>0</td><td>AO1in</td></tr> <tr><td>1</td><td>AO2in</td></tr> <tr><td>2</td><td>DO1in</td></tr> <tr><td>3</td><td>DO2in</td></tr> <tr><td>4</td><td>DO3in</td></tr> <tr><td>5</td><td>DO4in</td></tr> <tr><td>255</td><td>Undefined</td></tr> </table>	0	AO1in	1	AO2in	2	DO1in	3	DO2in	4	DO3in	5	DO4in	255	Undefined
0	AO1in																	
1	AO2in																	
2	DO1in																	
3	DO2in																	
4	DO3in																	
5	DO4in																	
255	Undefined																	

STRYKER VAV CONTROLLER

Object Name	Object Type/ID	Net Data Type	Default Val	Description																		
CfgLogicalOutVAVFreePlsOn	AV-1561	AV	255	<p>Free digital pulse ON output. Typically connected to a lighting relay. The output is controlled from the network command through Free1DigIn. Output Type: Binary Default: Undefined 0 ≤range ≤255</p> <table border="1"> <tr><td>0</td><td>AO1in</td></tr> <tr><td>1</td><td>AO2in</td></tr> <tr><td>2</td><td>DO1in</td></tr> <tr><td>3</td><td>DO2in</td></tr> <tr><td>4</td><td>DO3in</td></tr> <tr><td>5</td><td>DO4in</td></tr> <tr><td>255</td><td>Undefined</td></tr> </table>	0	AO1in	1	AO2in	2	DO1in	3	DO2in	4	DO3in	5	DO4in	255	Undefined				
0	AO1in																					
1	AO2in																					
2	DO1in																					
3	DO2in																					
4	DO3in																					
5	DO4in																					
255	Undefined																					
CfgLogicalOutVAVFreePlsOff	AV-1562	AV	255	<p>Free digital pulse OFF output. Typically connected to a lighting relay. The output is controlled from the network command through Free1DigIn. Output Type: Binary Default: Undefined 0 ≤range ≤255</p> <table border="1"> <tr><td>0</td><td>AO1in</td></tr> <tr><td>1</td><td>AO2in</td></tr> <tr><td>2</td><td>DO1in</td></tr> <tr><td>3</td><td>DO2in</td></tr> <tr><td>4</td><td>DO3in</td></tr> <tr><td>5</td><td>DO4in</td></tr> <tr><td>255</td><td>Undefined</td></tr> </table>	0	AO1in	1	AO2in	2	DO1in	3	DO2in	4	DO3in	5	DO4in	255	Undefined				
0	AO1in																					
1	AO2in																					
2	DO1in																					
3	DO2in																					
4	DO3in																					
5	DO4in																					
255	Undefined																					
CfgLogicalOutVAVReheat Mod	AV-1571	AV	255	<p>Reheat modulating output. Output Type: PWM, Float, Analog Current or Voltage Default: AO1 0 ≤range ≤255</p> <table border="1"> <tr><td>0</td><td>AO1in</td></tr> <tr><td>1</td><td>AO2in</td></tr> <tr><td>2</td><td>DO1in</td></tr> <tr><td>3</td><td>DO2in</td></tr> <tr><td>4</td><td>DO3in</td></tr> <tr><td>5</td><td>DO4in</td></tr> <tr><td>6</td><td>Float1in</td></tr> <tr><td>7</td><td>Float2in</td></tr> <tr><td>255</td><td>Undefined</td></tr> </table>	0	AO1in	1	AO2in	2	DO1in	3	DO2in	4	DO3in	5	DO4in	6	Float1in	7	Float2in	255	Undefined
0	AO1in																					
1	AO2in																					
2	DO1in																					
3	DO2in																					
4	DO3in																					
5	DO4in																					
6	Float1in																					
7	Float2in																					
255	Undefined																					

Object Name	Object Type/ID	Net Data Type	Default Val	Description																		
CfgLogicalOutVAVClgDm pr	AV-1572	AV	6	Cooling damper modulating output Output Type: PWM, Float, Analog Current or Voltage Default: Float1 $0 \leq \text{range} \leq 255$ <table border="1" data-bbox="906 422 1130 785"> <tr><td>0</td><td>AO1in</td></tr> <tr><td>1</td><td>AO2in</td></tr> <tr><td>2</td><td>DO1in</td></tr> <tr><td>3</td><td>DO2in</td></tr> <tr><td>4</td><td>DO3in</td></tr> <tr><td>5</td><td>DO4in</td></tr> <tr><td>6</td><td>Float1in</td></tr> <tr><td>7</td><td>Float2in</td></tr> <tr><td>255</td><td>Undefined</td></tr> </table>	0	AO1in	1	AO2in	2	DO1in	3	DO2in	4	DO3in	5	DO4in	6	Float1in	7	Float2in	255	Undefined
0	AO1in																					
1	AO2in																					
2	DO1in																					
3	DO2in																					
4	DO3in																					
5	DO4in																					
6	Float1in																					
7	Float2in																					
255	Undefined																					
CfgLogicalOutVAVPrphHt gMod	AV-1573	AV	255	Peripheral heat modulating output number 1. Default: Undefined $0 \leq \text{range} \leq 255$ <table border="1" data-bbox="906 888 1130 1251"> <tr><td>0</td><td>AO1in</td></tr> <tr><td>1</td><td>AO2in</td></tr> <tr><td>2</td><td>DO1in</td></tr> <tr><td>3</td><td>DO2in</td></tr> <tr><td>4</td><td>DO3in</td></tr> <tr><td>5</td><td>DO4in</td></tr> <tr><td>6</td><td>Float1in</td></tr> <tr><td>7</td><td>Float2in</td></tr> <tr><td>255</td><td>Undefined</td></tr> </table>	0	AO1in	1	AO2in	2	DO1in	3	DO2in	4	DO3in	5	DO4in	6	Float1in	7	Float2in	255	Undefined
0	AO1in																					
1	AO2in																					
2	DO1in																					
3	DO2in																					
4	DO3in																					
5	DO4in																					
6	Float1in																					
7	Float2in																					
255	Undefined																					
CfgLogicalOutVAVFanMod	AV-1574	AV	255	Fan modulating output Output Type: PWM, Float, Analog current or voltage Default: AO2 $0 \leq \text{range} \leq 255$ <table border="1" data-bbox="906 1367 1130 1705"> <tr><td>0</td><td>AO1in</td></tr> <tr><td>1</td><td>AO2in</td></tr> <tr><td>2</td><td>DO1in</td></tr> <tr><td>3</td><td>DO2in</td></tr> <tr><td>4</td><td>DO3in</td></tr> <tr><td>5</td><td>DO4in</td></tr> <tr><td>6</td><td>Float1in</td></tr> <tr><td>7</td><td>Float2in</td></tr> <tr><td>255</td><td>Undefined</td></tr> </table>	0	AO1in	1	AO2in	2	DO1in	3	DO2in	4	DO3in	5	DO4in	6	Float1in	7	Float2in	255	Undefined
0	AO1in																					
1	AO2in																					
2	DO1in																					
3	DO2in																					
4	DO3in																					
5	DO4in																					
6	Float1in																					
7	Float2in																					
255	Undefined																					

Object Name	Object Type/ID	Net Data Type	Default Val	Description																				
CfgLogicalOutVAVFreeMod	AV-1575	AV	255	<p>Free modulating output. The output is controlled from the network command through Free1ModIn. Output Type: PWM, Float, Analog Current or Voltage Default: Undefined 0 ≤ range ≤ 255</p> <table border="1"> <tr><td>0</td><td>AO1in</td></tr> <tr><td>1</td><td>AO2in</td></tr> <tr><td>2</td><td>DO1in</td></tr> <tr><td>3</td><td>DO2in</td></tr> <tr><td>4</td><td>DO3in</td></tr> <tr><td>5</td><td>DO4in</td></tr> <tr><td>6</td><td>Float1in</td></tr> <tr><td>7</td><td>Float2in</td></tr> <tr><td>255</td><td>Undefined</td></tr> </table>	0	AO1in	1	AO2in	2	DO1in	3	DO2in	4	DO3in	5	DO4in	6	Float1in	7	Float2in	255	Undefined		
0	AO1in																							
1	AO2in																							
2	DO1in																							
3	DO2in																							
4	DO3in																							
5	DO4in																							
6	Float1in																							
7	Float2in																							
255	Undefined																							
CfgLogicalOutVAVLedMod	AV-1576	AV	255	<p>Wall module Occupancy status LED output. Honeywell Conventional Wall Module: Output SubType: AO_0_10vdcDir Retrofit Jobs: Output SubType: AO_0_10vdcDir, AO_0_20maDir Default: Undefined 0 ≤ range ≤ 255</p> <table border="1"> <tr><td>8</td><td>AO1inLive</td></tr> <tr><td>9</td><td>AO2inLive</td></tr> <tr><td>255</td><td>Undefined</td></tr> </table> <table border="1"> <thead> <tr> <th>Effective Override State</th> <th>LED</th> </tr> </thead> <tbody> <tr> <td>OCCNUL (Cancel)</td> <td>Off</td> </tr> <tr> <td>Other values</td> <td>Off (treat as OccNul)</td> </tr> <tr> <td>BYPASS</td> <td>On</td> </tr> <tr> <td>UNOCC</td> <td>1 flash per second 0.3 sec ON</td> </tr> <tr> <td>OCC</td> <td>2 flashes per second 0.3 sec ON, 0.2 sec OFF, 0.3 sec ON</td> </tr> <tr> <td>STANDBY</td> <td>2 flashes per second</td> </tr> </tbody> </table>	8	AO1inLive	9	AO2inLive	255	Undefined	Effective Override State	LED	OCCNUL (Cancel)	Off	Other values	Off (treat as OccNul)	BYPASS	On	UNOCC	1 flash per second 0.3 sec ON	OCC	2 flashes per second 0.3 sec ON, 0.2 sec OFF, 0.3 sec ON	STANDBY	2 flashes per second
8	AO1inLive																							
9	AO2inLive																							
255	Undefined																							
Effective Override State	LED																							
OCCNUL (Cancel)	Off																							
Other values	Off (treat as OccNul)																							
BYPASS	On																							
UNOCC	1 flash per second 0.3 sec ON																							
OCC	2 flashes per second 0.3 sec ON, 0.2 sec OFF, 0.3 sec ON																							
STANDBY	2 flashes per second																							

## Variable Input

Table 23: Logical Outputs Enumeration Description

Object Name	Object Type/ID	Net Data Type SNVT	Description						
ApplicModelIn	AV-1471	AV	<p>This BACnet object is used to switch between off, auto, heating and cooling.</p> <p>0 – Auto reheating and cooling enabled</p> <p>1 – Heat enabled (warm air is supplied) and reheat is enabled.</p> <p>2 – Morning warm-up (warm air is supplied) and reheat follows the CfgMorningWarmupType configuration.</p> <p>3 – Cooling enabled (cool air is supplied) reheat locked out. Use this mode to disable reheat when boiler hot water is unavailable.</p> <p>4– night purge (outdoor air is supplied) 6 – fan, heating and cooling off</p> <p>9 – Fan Only, no heating or cooling All other inputs ignored.</p>						
ByPassIn	AV-1473	AV	<p>Network occupancy bypass command.</p> <p>Note that the network bypass command has priority over the network occupancy override input (OccCmdIn).</p> <table border="1"> <thead> <tr> <th>State</th> <th>Meaning</th> </tr> </thead> <tbody> <tr> <td>1</td> <td>The node should bypass the time of day schedule (subject to occupancy arbitration logic).</td> </tr> <tr> <td>0</td> <td>The node should not bypass the time of day schedule</td> </tr> </tbody> </table>	State	Meaning	1	The node should bypass the time of day schedule (subject to occupancy arbitration logic).	0	The node should not bypass the time of day schedule
State	Meaning								
1	The node should bypass the time of day schedule (subject to occupancy arbitration logic).								
0	The node should not bypass the time of day schedule								
DLCShedIn	AV-1474	AV	<p>Network command for Demand Limit Control</p> <p>Notes:</p> <ol style="list-style-type: none"> <li>When DLC is active, the control loop setpoint DLCShiftSetpt is shifted in the energy savings direction.</li> <li>When DLC is inactive, the control loop normal setpoint is restored using a 30 minute ramp.</li> </ol>						
DischargeAirTempIn	AV-1181	AV	<p>Discharge air temperature</p> <p>Typically used as an override to the local input. 32 ≤ range ≤212 F</p>						

Object Name	Object Type/ID	Net Data Type SNVT	Description
EmergCmdIn	AV-1182	AV	Emergency BACnet object command that overrides normal control action during a given emergency (such as a fire). The valid enumerated values have the following meanings: 0 – Normal with no override 1 – Pressurize, move the damper to the emergency pressurize position. 2 – Depressurize, move the damper to the emergency depressurize position. 3 – Purge, move the damper to the emergency purge position 4 – Shutdown All other values are ignored. Note: EmergCmdIn has priority over the network flow override command. If the emergency command is active (values 1 to 4), the series or parallel terminal fan is disabled. EmergCmdIn has priority over the network command FanStateIn (AV-1183) and FanValueIn (AV-1184). EmergCmdIn will override a disabled controller.
<b>Fan Override</b> signal. Typically used during airflow balancing. Notes: Emergency command (EmergCmdIn) has priority over (FanStateIn and FanValueIn) override Fan override alarm is annunciated when this BACnet object is active.			
FanValueIn	AV-1184	AV	Modulating override signal If CfgFanType = 4 (parallel fan with spd control) Then override fan modulating output Else ignore override value
FanStateIn	AV-1183	AV	0 = fan off 1 = fan on NUL = no override Note: The state value must be set to NULL to disable the override signal
FlowOffsetIn	AV-1185	AV	Airflow offset to the occupied minimum airflow setpoint. Typically used to improve indoor air quality. -100 ≤ range ≤ 100% Pressure dependent, Occupied & Valid Value EffMinFlowSP = MinFlowSP + FlowOffsetIn Pressure independent, Occupied & Valid Value EffMinFlowSP = MinFlowSP +(FlowOffsetIn*MaxFlow/100)
<b>Flow Override:</b> Airflow cooling output override. Used for flow balancing or to command the VAV box to manual states.			
FlowOverrideStateIn	AV-1186	AV	0 = no override (normal operation) 1 = manual flow damper position 2 = effFlowSetPt is set to the ManFlowValue input 3 = Flow percent 4 = open damper 5 = close damper 6 = effFlowSetPt is set to the minFlowSetPt input 7 = effFlowSetPt is set to the maxFlowSetPt input. (all others) = no override Notes: All active values (non zero) disable the staged heating.



Object Name	Object Type/ID	Net Data Type SNVT	Description															
FlowOverridePctIn	AV-1187	AV	<p>Manual percent value.</p> <table border="1"> <thead> <tr> <th>State</th> <th>Function</th> </tr> </thead> <tbody> <tr> <td>1: Manual Position</td> <td>Damper position set to the percent value.</td> </tr> <tr> <td>3: Flow Percent</td> <td>Command flow set to the percent value.</td> </tr> </tbody> </table> <p>range 0 ... 100 %</p>	State	Function	1: Manual Position	Damper position set to the percent value.	3: Flow Percent	Command flow set to the percent value.									
State	Function																	
1: Manual Position	Damper position set to the percent value.																	
3: Flow Percent	Command flow set to the percent value.																	
FlowOverrideFlowIn	AV-1188	AV	<p>Manual flow value (cfm). The value used when FlowOverrideStatIn is set to a value of "2".</p> <p>range 0 ... 138858 cfm</p>															
FlowTrackIn	AV-1189	AV	<p>This BACnet object is bound to the FlowTrackOut (AV-1148) of the previous node in the flow tracking daisy chain.</p> <p>0 ≤ range ≤ 138850 cfm</p>															
Free1DigIn	AV-1190	AV	<p>The BACnet object Free1Dig allows to control a user determined binary load with an unused digital output(s) or floating output synchronization. The "Free1" digital output is intended to drive a non-latching relay while the "FreePulseOn" and "FreePulseOff" digital outputs are intended to drive a latching relay. One second pulses are applied to the latching relays when the input BACnet object changes state.</p> <table border="1"> <thead> <tr> <th>State</th> <th>Value</th> <th>Meaning</th> </tr> </thead> <tbody> <tr> <td>Off</td> <td>Don't care</td> <td>The corresponding free logical output (and therefore the physical output, if configured) is off.</td> </tr> <tr> <td>On</td> <td>0</td> <td>The corresponding free logical output (and therefore the physical output, if configured) is off. If the node receives this combination of state and value, then state is set to Off</td> </tr> <tr> <td>On</td> <td>Not Zero</td> <td>The corresponding free logical output (and therefore the physical output, if configured) is on.</td> </tr> <tr> <td>Null</td> <td>Don't care</td> <td>The BACnet object is not bound, the communications path from the sending node has failed, or the sending node has failed. The corresponding free logical output does not change if the BACnet object input fails.</td> </tr> </tbody> </table>	State	Value	Meaning	Off	Don't care	The corresponding free logical output (and therefore the physical output, if configured) is off.	On	0	The corresponding free logical output (and therefore the physical output, if configured) is off. If the node receives this combination of state and value, then state is set to Off	On	Not Zero	The corresponding free logical output (and therefore the physical output, if configured) is on.	Null	Don't care	The BACnet object is not bound, the communications path from the sending node has failed, or the sending node has failed. The corresponding free logical output does not change if the BACnet object input fails.
State	Value	Meaning																
Off	Don't care	The corresponding free logical output (and therefore the physical output, if configured) is off.																
On	0	The corresponding free logical output (and therefore the physical output, if configured) is off. If the node receives this combination of state and value, then state is set to Off																
On	Not Zero	The corresponding free logical output (and therefore the physical output, if configured) is on.																
Null	Don't care	The BACnet object is not bound, the communications path from the sending node has failed, or the sending node has failed. The corresponding free logical output does not change if the BACnet object input fails.																

Object Name	Object Type/ID	Net Data Type SNVT	Description												
Free1ModIn	AV-1191	AV	The BACnet object Free1Mod allows to control: Actuator with an unused analog output Peripheral heat valve minimum position $0 \leq \text{range} \leq 100\%$												
<p><b>Heating override:</b> Applies to peripheral heat &amp; reheat. Notes: This override duplicates the functionality of ValveOverride. Use OvrPeriphPos and OvrReheatPos to command peripheral and reheat valves simultaneously.</p>															
HtgOvrStateIn	AV-1192	AV	0 = no override (normal operation) 1 = manual reheat & peripheral flow position 4 = open reheat & peripheral valve 5 = close reheat & peripheral valve (all others) = no override												
HtgOvrPctIn	AV-1193	AV	Manual percent flow value. range 0 ... 100 %												
ManOccln	AV-1196	AV	Network command to force the VAV box into a specific manual occupancy mode. This is an input from a network connected operator interface or other node that indicates the state of a manual occupancy control thus overriding the scheduled occupancy state. It is used along with other occupancy inputs to calculate the effective occupancy of the node. 0: Occupied 1: Unoccupied 2: Bypass 3: Standby 255: null, ignore occupancy command. Notes Bypass: indicates that the space is occupied for BypassTime seconds after ManOccln is first set to OC_BYPASS. The timing is done by the bypass timer in this node. If ManOccln changes to another value the manual occupancy state assumes the new value independent of the bypass timer. If ManOccln changes back to a null value and the bypass timer is active, it will return to the Bypass mode.												
MonDigIn	AV-1197	AV	Monitor digital input. Typically used to override the local digital monitor input. <table border="1" data-bbox="771 1371 1373 1619"> <thead> <tr> <th>State</th> <th>Value</th> <th>Meaning</th> </tr> </thead> <tbody> <tr> <td>Off</td> <td>Don't care</td> <td>Override status inactive</td> </tr> <tr> <td>On</td> <td>Don't care</td> <td>Override status active</td> </tr> <tr> <td>Null</td> <td>Don't care</td> <td>No Override</td> </tr> </tbody> </table> <p>Note: The state value must be set to NULL to disable the override signal</p>	State	Value	Meaning	Off	Don't care	Override status inactive	On	Don't care	Override status active	Null	Don't care	No Override
State	Value	Meaning													
Off	Don't care	Override status inactive													
On	Don't care	Override status active													
Null	Don't care	No Override													
MonSensorIn	AV-1198	AV	Monitor sensor. Typically used to override the local monitor analog sensor. $-3.399999952144364E38 \leq \text{range} \leq 3.399999952144364E38$												

Object Name	Object Type/ID	Net Data Type SNVT	Description																				
OccCmdIn	AV-1199	AV	<p>Allows an occupancy sensor at another node to be used as the occupancy sensor for this node and is typically bound to the occupancy sensor output from another node. The OccCmdIn must show UnOcc for the 300 seconds before OccSensorIn is changed to UnOcc. This makes it possible for several occupancy sensors to be "ORed" together by binding them all to OccSensorIn. If any one bound occupancy sensor shows Occ, then OccSensorIn shows Occ for up to the 300 seconds after the last sensor shows Occ.</p> <p>0, 2, 3: Space is Occupied 1: Space is unoccupied 255: sensor not connected Notes: If a local occupancy sensor has been configured, the local sensor is logically ORed with the network signal.</p>																				
OdTempIn	AV-1200	AV	<p>Outdoor air temperature. Used to enable peripheral heat minimum water flow below 40F outdoor air temperature. -40 ≤ range ≤ 122F</p>																				
SetpointIn	AV-1201	AV	<p>This object is used to determine the temperature control point (center setpoint) of the node. If SetPointIn is valid, then it is used to determine the control point of the node. If SetPointIn is invalid, then other means are used to determine the control point 40 ≤ range ≤ 100 F</p> <table border="1" data-bbox="878 989 1469 1192"> <thead> <tr> <th colspan="2">New "Temporary" Variables</th> </tr> </thead> <tbody> <tr> <td>OccCool =</td> <td>SetPointIn + ZEB_OCC / 2</td> </tr> <tr> <td>OccHeat =</td> <td>SetPointIn - ZEB_OCC / 2</td> </tr> <tr> <td>StandbyCool =</td> <td>SetPointIn + ZEB_STDBY / 2</td> </tr> <tr> <td>StanbyHeat =</td> <td>SetPointIn - ZEB_STDBY / 2</td> </tr> </tbody> </table> <p>where: ZEB_OCC = OccCool - OccHeat ZEB_STDBY = StandbyCool - StandbyHeat Setpoint Override Priority</p> <table border="1" data-bbox="878 1346 1469 1549"> <thead> <tr> <th>Priority</th> <th>Setpoint Input</th> </tr> </thead> <tbody> <tr> <td>1</td> <td>SetPointOvrIn</td> </tr> <tr> <td>2</td> <td>SetPointIn</td> </tr> <tr> <td>3</td> <td>SetPtOffsetIn</td> </tr> <tr> <td>4</td> <td>Wall Module center setpoint</td> </tr> </tbody> </table> <p>Note: This input is intended for a network connected wall module.</p>	New "Temporary" Variables		OccCool =	SetPointIn + ZEB_OCC / 2	OccHeat =	SetPointIn - ZEB_OCC / 2	StandbyCool =	SetPointIn + ZEB_STDBY / 2	StanbyHeat =	SetPointIn - ZEB_STDBY / 2	Priority	Setpoint Input	1	SetPointOvrIn	2	SetPointIn	3	SetPtOffsetIn	4	Wall Module center setpoint
New "Temporary" Variables																							
OccCool =	SetPointIn + ZEB_OCC / 2																						
OccHeat =	SetPointIn - ZEB_OCC / 2																						
StandbyCool =	SetPointIn + ZEB_STDBY / 2																						
StanbyHeat =	SetPointIn - ZEB_STDBY / 2																						
Priority	Setpoint Input																						
1	SetPointOvrIn																						
2	SetPointIn																						
3	SetPtOffsetIn																						
4	Wall Module center setpoint																						

Object Name	Object Type/ID	Net Data Type SNVT	Description										
SetpointOvrIn	AV-1202	AV	<p>This object is used to temporarily override the temperature control center setpoint. Please refer to SetPointIn for details.  <math>40 \leq \text{range} \leq 100 \text{ F}</math>                      Setpoint Override Priority</p> <table border="1"> <thead> <tr> <th>Priority</th> <th>Setpoint Input</th> </tr> </thead> <tbody> <tr> <td>1</td> <td>SetPointOvrIn</td> </tr> <tr> <td>2</td> <td>SetPointIn</td> </tr> <tr> <td>3</td> <td>SetPtOffsetIn</td> </tr> <tr> <td>4</td> <td>Wall Module center setpoint</td> </tr> </tbody> </table> <p>Note: This input is dedicated to a workstation or network connected tool and should not be bound to a network wall module.</p>	Priority	Setpoint Input	1	SetPointOvrIn	2	SetPointIn	3	SetPtOffsetIn	4	Wall Module center setpoint
Priority	Setpoint Input												
1	SetPointOvrIn												
2	SetPointIn												
3	SetPtOffsetIn												
4	Wall Module center setpoint												
SetpointOffsetIn	AV-1203	AV	<p>This BACnet object is used to temporarily shift the effective heating and cooling setpoint. The value is added to the effective setpoint. The shift is effective setpoint for Occupied, Bypass and Standby modes.  <math>-10 &lt; \text{range} &lt; +10 \Delta\text{F}</math> Setpoint Override Priority</p> <table border="1"> <thead> <tr> <th>Priority</th> <th>Setpoint Input</th> </tr> </thead> <tbody> <tr> <td>1</td> <td>SetPointOvrIn</td> </tr> <tr> <td>2</td> <td>SetPointIn</td> </tr> <tr> <td>3</td> <td>InSetPtOffsetIn</td> </tr> <tr> <td>4</td> <td>Wall Module center setpoint</td> </tr> </tbody> </table>	Priority	Setpoint Input	1	SetPointOvrIn	2	SetPointIn	3	InSetPtOffsetIn	4	Wall Module center setpoint
Priority	Setpoint Input												
1	SetPointOvrIn												
2	SetPointIn												
3	InSetPtOffsetIn												
4	Wall Module center setpoint												
<p>In some cases a sending node(master VAV controller) with a wall module may be used to control the damper, ReHeat and Peripheral heat of one or more other receiving nodes (satellite VAV controllers) that do not have a wall module. To use this feature:                      All nodes involved must be configured to have the same kind of ReHeat via ReHeatType.                      The satellite receiving nodes must have FlowControlType set to ShareWallModule.                      The satellite receiving nodes must have 'ModeShareIn, ReheatStgsShareIn, ReheatCmdIn, TempFlowCmdIn, EffectOccln, PeriphStgIn and PeriphCmdIn' bound to 'ModeShareOut, ReheatCmdOut, PeriphCmdOut and TempFlowCmdOut' of a node having a wall module.</p> <p>Notes:                      'ModeShareIn, ReheatStgsShareIn, ReheatCmdIn, TempFlowCmdIn, EffectOccln, PeriphStgIn and PeriphCmdIn' can be used as a fall back strategy for a Wall Module space temperature sensor failure. In this case, FlowControlType is set to normal. When the space temperature sensor fails, the master VAV controller will take over control of the satellite VAV (controller with failed space temperature sensor).                      'ModeShareIn, ReheatStgsShareIn, ReheatCmdIn, TempFlowCmdIn, EffectOccln, PeriphStgIn and PeriphCmdIn'.TempFlowCmd must be a valid numerical value before any Wall Module sharing functions are enabled.</p>													

Object Name	Object Type/ID	Net Data Type SNVT	Description
ModeShareIn	AV-1204	AV	<p>Master Node Status</p> <p>0 - Startup wait</p> <p>1 - Heat</p> <p>2 - Cool</p> <p>3 - Reheat</p> <p>4 - Morn_Warm</p> <p>5 - Night Purge</p> <p>6 - Pressurize</p> <p>7 - Depressurize</p> <p>8 - Trackflow</p> <p>Ignored by satellite node</p> <p>9 - Manual Damper Position Ignored by satellite node</p> <p>10 - Manual Flow</p> <p>Ignored by satellite node</p> <p>11 - Freeze Protect</p> <p>12 - Factory Test.</p> <p>Not supported Note 1</p> <p>13 - IO Test</p> <p>Not Supported. Note 1</p> <p>14 - Float out sync Not Supported.</p> <p>15 - Disabled</p> <p>Not Supported. Note 1</p> <p>16 - Manual</p> <p>Not Supported. Note 1</p> <p>17 - Emerg Command Purge</p> <p>18 - Emerg Command Shutdown</p> <p>19 - Htg &amp; Clg disabled.</p> <p>Ignored by satellite node</p> <p>20 - Fan only</p> <p>Ignored by satellite node</p> <p>Note: Mode 6 (Pressurize) and Mode 7 (Depressurize) are ignored if the controller is disabled. Use a BACnet object [EmergCmdIn (AV-1182)] to override a slave controller in the disabled mode.</p>
ReheatStgsShareIn	AV-1205	AV	<p>Indicates the number of stages that should be turned on in the receiving nodes</p> <p>0 ≤ range ≤ 3</p>
ReheatCmdIn	AV-1206	AV	<p>Indicates the amount of modulating ReHeat that should be turned on in the receiving nodes.</p> <p>0 ≤ range ≤ 100%</p>
TempFlowCmdIn	AV-1207	AV	<p>Output command of the temperature control loop in terms of percentage (%) of flow capacity mapped to the minimum - maximum flow range (zero percent as minimum flow and 100% as maximum flow).</p> <p>0 ≤ range ≤ 100%</p>
EffectOccln	AV-1208	AV	<p>Effective occupancy</p> <p>0: Occupied</p> <p>1: Unoccupied</p> <p>2: Bypass</p> <p>3: Standby</p>

Object Name	Object Type/ID	Net Data Type SNVT	Description
PeriphStgIn	AV-1209	AV	Indicates the number of peripheral heat stages that should be turned on in the receiving nodes 0 ≤ range ≤ 1
PeriphCmdIn	AV-1210	AV	Indicates the amount of modulating peripheral heat that should be turned on in the receiving nodes. 0 ≤ range ≤ 100%
SpaceCO2In	AV-1211	AV	Space CO <sub>2</sub> concentration. A valid input value overrides the local CO <sub>2</sub> sensor. 0 ≤ range ≤ 5000 PPM
SpaceHumIn	AV-1212	AV	Space relative humidity. Typically used to override the local sensor value. 0 ≤ range ≤ 100%
SpaceTempIn	AV-1213	AV	Network space temperature input. The BACnet object overrides the local temperature sensor. 14 ≤ range ≤ 122F
SupplyTempIn	AV-1214	AV	Supply duct air input temperature. This value is used for automatic heating and cooling mode changeover. 32 ≤ range ≤ 212 F
<p><b>Tod Event:</b> This object is used to command the Space Comfort Controller into different occupancy modes. It is typically sent by a scheduler or a supervisory node. If the network signal is valid, the network overrides the local time schedule.</p>			
TodEventCurrStateIn	AV-1215	AV	Current scheduled state 0: Occupied 1: Unoccupied 3: Standby 255: null
TodEventNextStateIn	AV-1216	AV	Next scheduled state 0: Occupied 1: Unoccupied 3: Standby 255: null
TodEventTimeToNextStateIn	AV-1217	AV	Time to next scheduled state. 0 to 65,534 minutes
<p><b>Valve Override:</b> Allows override of valves for hydronic balancing. Writing of 0-100% overrides valve position or percent number of stages to commanded value. Writing invalid (NaN) or (+inf) reverts to automatic operation.</p> <p>Notes: This override duplicates the functionality of HtgOvrIn. Use (OvrPeriphPos and OvrReheatPos) to command peripheral and reheat valves individually.</p>			
OvrReheatPos	AV-1194	AV	Reheat 0 ≤ range ≤ 100%, invalid
OvrPeriphPos	AV-1195	AV	Peripheral heat 0 ≤ range ≤ 100%, invalid

Object Name	Object Type/ID	Net Data Type SNVT	Description						
WindowIn	AV-1218	AV	<p>Allows the window sensor from another node to be used as the window sensor and is typically bound to WindowOut of another node. WindowIn must show that the window is closed for the 300 seconds before the logical window signal is changed to window closed. This makes it possible for several window sensors to be "ORed" together by binding them all to WindowIn. If any one bound window sensor shows window open, then WindowIn shows window open for up to the 300 seconds after the last sensor shows window closed. The states are listed below:</p> <table border="1" data-bbox="878 583 1398 747"> <thead> <tr> <th data-bbox="878 583 1143 625">State</th> <th data-bbox="1143 583 1398 625">Meaning</th> </tr> </thead> <tbody> <tr> <td data-bbox="878 625 1143 705">SW_OFF or SW_NUL or other</td> <td data-bbox="1143 625 1398 705">Window Closed</td> </tr> <tr> <td data-bbox="878 705 1143 747">SW_ON</td> <td data-bbox="1143 705 1398 747">Window Open</td> </tr> </tbody> </table> <p>WindowOpen indicates the current state of the window sensors and is calculated from WindowIn.state and the local occupancy sensor. The local sensor and WindowIn are "ORed" together. If either the local sensor or WindowIn shows that the window is open (WindowIn.state = SW_ON), then WindowOpen shows that the window is open. 1 means that the window is open and 0 means that the window is closed. When the window, the controller mode is switched to FREEZE_PROTECT. TempMode = Off Heating SetPt = 46F</p>	State	Meaning	SW_OFF or SW_NUL or other	Window Closed	SW_ON	Window Open
State	Meaning								
SW_OFF or SW_NUL or other	Window Closed								
SW_ON	Window Open								

## Variable Output

Table 24: Variable Outputs

Object Name	Object Type/ID	Net Data Type	Description
<b>Application Alarm:</b> Application alarms group 1: 0: inactive alarm 1: active alarm			
LowFlowAlarmOut	AV-1521	AV	Low airflow alarm (pressure independent control) 10 minute alarm delay. Occupied AND Damper Control ? 100% AND PressureIndp Control AND Airflow < ((AirflowSP – DeadBand)*0.95))
AirFlowOvrAlarmOut	AV-1522	AV	Airflow control loop override alarm
EmrgOvrAlarmOut	AV-1523	AV	Emergency override alarm. This indicates that the network command EmrgCmd is active.
HtgOvrAlarmOut	AV-1524	AV	Reheat or peripheral heat override alarm
FanOvrAlarmOut	AV-1525	AV	Fan in manual override state.
FrostAlarmOut	AV-1526	AV	Space low temperature (42.8F) alarm
IAQAlarmOut	AV-1527	AV	The indoor air quality sensor has detected that the indoor air quality is poorer than the desired standard. Alarm disabled when not occupied or freeze protect mode.
InvalidSpAlarmOut	AV-1528	AV	One of the Set Points is not in the valid range. The node issues an INVALID_SET_POINT alarm when: (1) Any set point lies outside the 40F to 100F range (2) unoccupied heat > occupied heat (3) occupied heat > occupied cool (4) occupied cool > unoccupied cool (5) standby heat > standby cool
SpaceTempAlarmOut	AV-1529	AV	Occupied space temperature alarm. Alarm locked out until the space effective occupancy is occupied and after a fixed delay. Refer to (CfgSpcTempAlmHiLimit, CfgSpcTempAlmLoLimit and CfgSpcTempAlmDelay) for configuration details.
Alm1			Future alarm.
Alm2			Future alarm.
Alm3			Future alarm.
Alm4			Future alarm.
Alm5			Future alarm.
Alm6			Future alarm.
Alm7			Future alarm.
BoxFlow	AV-1012	AV	The airflow output of the VAV Box cooling stream. $0 \leq \text{range} \leq 138850$ cfm



Object Name	Object Type/ID	Net Data Type	Description						
BypassOut	AV-1531	AV	<p>This allows a wall module at one node to be used to override the scheduled occupancy of another node. The node with ByPassIn bound normally does not have a wall module. See the EffectOcc and OverRide for more details.</p> <table border="1" data-bbox="760 390 1333 512"> <thead> <tr> <th data-bbox="760 390 899 432">State</th> <th data-bbox="899 390 1333 432">Description</th> </tr> </thead> <tbody> <tr> <td data-bbox="760 432 899 474">0</td> <td data-bbox="899 432 1333 474">Override is not Bypass</td> </tr> <tr> <td data-bbox="760 474 899 512">1</td> <td data-bbox="899 474 1333 512">Override is Bypass</td> </tr> </tbody> </table> <p>Note: Do not enable Guaranteed Periodic Update (GPU) for this AV.</p>	State	Description	0	Override is not Bypass	1	Override is Bypass
State	Description								
0	Override is not Bypass								
1	Override is Bypass								
<p><b>Node Status Group - Binary &amp; Enumerated Data</b>                      This is a limited summary of VAV binary and enumerated data intended for Workstation Graphics. This NV is suitable for data transfer using a network NV binding or polling. Since the Significant event notification is set to a zero value, the polled information is always current.</p>									
ModeShareOut	AV-1162	AV	<p>Indicates the current mode of the node determined by many inputs and arbitrated by control logic.</p> <ul style="list-style-type: none"> <li>0 - Startup wait</li> <li>1 - Heat</li> <li>2 - Cool</li> <li>3 - Reheat</li> <li>4 - Morn_Warm</li> <li>5 - Night Purge</li> <li>6 - Pressurize</li> <li>7 - Depressurize</li> <li>8 - Trackflow</li> <li>9 - Manual Damper Position</li> <li>10 - Manual Flow</li> <li>11 - Freeze Protect</li> <li>12 - Factory Test.</li> </ul> <p>Not supported Note 1</p> <ul style="list-style-type: none"> <li>13 - IO Test</li> </ul> <p>Not Supported. Note 1</p> <ul style="list-style-type: none"> <li>14 - Float out sync Not Supported.</li> <li>15 - Disabled</li> </ul> <p>Not Supported. Note 1</p> <ul style="list-style-type: none"> <li>16 - Manual</li> </ul> <p>Not Supported. Note 1</p> <ul style="list-style-type: none"> <li>17 - Emerg Command Purge</li> <li>18 - Emerg Command Shutdown</li> <li>19 - Htg and Clg Disabled.</li> <li>20 - Fan only</li> </ul> <p>Notes:                      Mode 6 (Pressurize) and Mode 7 (Depressurize) are ignored if the controller is disabled. Use network input EmergCmdIn to override a slave controller in the disabled mode.</p>						
EffectOccOut	AV-1146	AV	<p>Effective occupancy</p> <ul style="list-style-type: none"> <li>0: Occupied</li> <li>1: Unoccupied</li> <li>2: Bypass</li> <li>3: Standby</li> </ul>						

Object Name	Object Type/ID	Net Data Type	Description								
OverRideOut	AV-1486	AV	Effective manual override state. The result of arbitration of inputs from: Network Man Occ and the Wall Module bypass signal. 0: Occupied 1: Unoccupied 2: Bypass 3: Standby								
TodEventCurrStateOutput	AV-1172	AV	Scheduled occupancy state. 0: Occupied 1: Unoccupied 3: Standby 255: Null								
NetManOccOut	AV-1343	AV	Reports the network manual occupancy state from ManOccIn. 0: Occupied 1: Unoccupied 2: Bypass 3: Standby 255: null								
SensorOccOut	AV-1161	AV	Indicates the current state of the sensed occupancy <table border="1" data-bbox="656 825 1328 1016"> <thead> <tr> <th>Output</th> <th>Meaning</th> </tr> </thead> <tbody> <tr> <td>0 Oc</td> <td>The space is occupied</td> </tr> <tr> <td>1 UnOcc1</td> <td>The space is not occupied</td> </tr> <tr> <td>255 Null</td> <td>The occupancy sensor is not configured</td> </tr> </tbody> </table>	Output	Meaning	0 Oc	The space is occupied	1 UnOcc1	The space is not occupied	255 Null	The occupancy sensor is not configured
Output	Meaning										
0 Oc	The space is occupied										
1 UnOcc1	The space is not occupied										
255 Null	The occupancy sensor is not configured										
ReheatStgsOut	AV-1156	AV	Heating stages active $0 \leq \text{range} \leq 3$								
PerphHtgStgsOut	AV-1154	AV	Peripheral heat stage 1 0: inactive 1: active								
AuxOnOut	AV-1487	AV	Auxiliary circuit status 0 - effective occupancy is not Occ 1 - effective occupancy is Occ								
FanOnOut	AV-1538	AV	Fan digital output status 0 - off 1 - on								
DLCShedOut	AV-1140	AV	Indicates the status of the Demand limit control load shed. 0 - inactive 1 - active								
HeatCoolSwitchOut	AV-1532	AV	Heat Cool Change Over Switch 0 - Cool Mode (cool air is supplied to the ZT) 1 - Heat Mode (warm air is supplied to the ZT)								
WindowOpenOut	AV-1534	AV	Indicates the current state of the window sensors (local input, BACnet object or Share input) 1 - that the window is open 0 - that the window is closed.								
LowFlowAlarmOut	AV-1535	AV	Low airflow alarm 0 - inactive 1 - active								
IaqOvrrOut	AV-1536	AV	IAQ override alarm. The space CO <sub>2</sub> sensor exceeds the high limit. 0 - inactive 1 - active								

Object Name	Object Type/ID	Net Data Type	Description												
Free1OnOut	AV-1537	AV	Free digital output # 1 status. Controlled by a BACnet objectFree1DigIn 0 – inactive 1 – active												
MonSwOut	AV-1539	AV	The state of the digital input wired to a general purpose monitor switch 1 - switch is closed 0 - switch is open												
SpaceTempAlarmOut	AV-1529	AV	Occupied Space Temperature alarm 0 – inactive 1 – active												
Future															
<b>Node Status Group 2– Analog Data</b>															
This is a limited summary of VAV analog data intended for Workstation Graphics.															
EffectSetPtOut	AV-1147	AV	Space temperature effective setpoint 40 ≤range ≤100F												
SpaceTempOut	AV-1168	AV	Space temperature 14 ≤range ≤122F												
Space_CO2_Out	AV-1542	AV	Space CO <sub>2</sub> 0 ≤ range ≤ 5000 PPM Invalid = 65535												
SpaceHumOut	AV-1167	AV	Space relative humidity 0 ≤range ≤100% Invalid = 127.5												
DischargeTempOut	AV-1541	AV	Discharge air temperature setpoint -49 ≤range ≤233.6 F												
SupplyAirTempOut	AV-1540	AV	Duct in supply air temperature. 32 ≤ range ≤ 212 F												
FreshAir_Ratio_Out	AV-1546	AV	100 * (FreshAirRequired / BoxFlow) 0 ≤range ≤150%												
EffectFlowCSPOut	AV-1144	AV	Box airflow setpoint 0 ≤ range ≤ 138850 cfm												
BoxFlow	AV-1012	AV	Box airflow 0 ≤ range ≤ 138850 cfm												
DamperPosOut	AV-1543	AV	Airflow damper position 0 ≤range ≤100												
ReheatPosOut	AV-1155	AV	Reheat valve position 0 ≤range ≤100												
PeriphHtgPosOut	AV-1153	AV	Peripheral heating valve position 0 ≤range ≤100												
UnitFanOutputOut	AV-1178	AV	Fan speed in percent 0 ≤range ≤100 Invalid = 127.5												
Free1ModOut	AV-1180	AV	Free modulating output controlled by Free1DigIn 0 ≤range ≤100 Invalid = 127.5												
DLCShedInputOut	AV-1472	AV	Indicates the state of DlcShedIn. <table border="1" data-bbox="760 1545 1495 1709"> <thead> <tr> <th>State</th> <th>Value</th> <th>Meaning</th> </tr> </thead> <tbody> <tr> <td>0</td> <td>0</td> <td>DLC input inactive</td> </tr> <tr> <td>1</td> <td>100</td> <td>DLC input active</td> </tr> <tr> <td>Null</td> <td>Null</td> <td>DLC input inactive</td> </tr> </tbody> </table>	State	Value	Meaning	0	0	DLC input inactive	1	100	DLC input active	Null	Null	DLC input inactive
State	Value	Meaning													
0	0	DLC input inactive													
1	100	DLC input active													
Null	Null	DLC input inactive													
DischargeAirTempOut	AV-1141	AV	Discharge air temperature -49 ≤ range ≤ 233.6 F Sen Delta = 10.0 F												
EffCnrSetPtOut	AV-1142	AV	Effective space temperature center setpoint. EffCnrSetPt = EffHtgSP + ((EffClgSP – EffHtgSP)/2) -30 ≤ range ≤ 100F												

Object Name	Object Type/ID	Net Data Type	Description												
EffControlDbOut	AV-1143	AV	Effective temperature control deadband. EffControlDb = EffClgSP – EffHtgSP 0 ≤ range ≤ 60ΔF												
EffectFlowCSPOut	AV-1144	AV	The effective airflow setpoint. 0 ≤ range ≤ 138850 cfm												
EffectModeOut	AV-1145	AV	Effective network commanded HVAC Mode 0 – Auto heating and cooling 1 – Heat 2 – Morning warm-up 3 – Cooling 4 – night purge 6 – heating and cooling off 9 – Fan Only, no heating or cooling												
EffectOccOut	AV-1146	AV	The effective occupancy state. 0: Occupied 1: Unoccupied 2: Bypass 3: Standby												
DLCShedInputOut	AV-1472	AV	Indicates the state of DlcShedIn. <table border="1" data-bbox="657 850 1388 1018"> <thead> <tr> <th>State</th> <th>Value</th> <th>Meaning</th> </tr> </thead> <tbody> <tr> <td>0</td> <td>0</td> <td>DLC input inactive</td> </tr> <tr> <td>1</td> <td>100</td> <td>DLC input active</td> </tr> <tr> <td>Null</td> <td>Null</td> <td>DLC input inactive</td> </tr> </tbody> </table>	State	Value	Meaning	0	0	DLC input inactive	1	100	DLC input active	Null	Null	DLC input inactive
State	Value	Meaning													
0	0	DLC input inactive													
1	100	DLC input active													
Null	Null	DLC input inactive													
EffectSetPtOut	AV-1147	AV	The effective space temperature setpoint. -30 ≤ range ≤ 100F												
FanOnOut	AV-1538	AV	Indicates the fan status <table border="1" data-bbox="657 1129 1226 1291"> <thead> <tr> <th>State</th> <th>Meaning</th> </tr> </thead> <tbody> <tr> <td>OFF</td> <td>Fan output inactive</td> </tr> <tr> <td>ON</td> <td>Fan output active</td> </tr> <tr> <td>NUL</td> <td>Fan output inactive</td> </tr> </tbody> </table>	State	Meaning	OFF	Fan output inactive	ON	Fan output active	NUL	Fan output inactive				
State	Meaning														
OFF	Fan output inactive														
ON	Fan output active														
NUL	Fan output inactive														
FlowTrackOut	AV-1148	AV	Reports the airflow measured at this node plus FlowTrackIn (AV-1189). If a flow sensor error has been detected or Pressure Dependent is True, then FlowTrackOut is set to Invalid. If FlowTrackIn (AV-1189) is Invalid, FlowTrackOut is also set to Invalid. 0 ≤ range ≤ 138850 cfm												
FreshAirRatioOut	AV-1149	AV	This is FreshAirRequired divided by BoxFlow. When FreshAirRatio is Large (greater than or equal to 100 percent), there is insufficient fresh air being supplied to the zone even if the supply air is 100 percent fresh air. When FreshAirRatio is small, there is sufficient fresh air being supplied to the zone. FreshAirRatio is used for coordination within the HVAC subsystem and energy management decisions by the supply equipment. If the actual FreshAirRatio is greater than 150 percent, FreshAirRatio reports 150 percent. If BoxFlow is zero, then FreshAirRatio is Invalid. If the calculated ratio is greater than the range that can be handled by a two byte number, then FreshAirRatio is set to the biggest number possible before Invalid is indicated. The FreshAirRatio is zero when the zone is: UnOccupied, Bypass, configured for flow tracking or freeze protect mode 0 ≤ range ≤ 150%												

Object Name	Object Type/ID	Net Data Type	Description	
IAQOvrOut	AV-1544	AV	Allows an indoor air quality sensor to be shared with other nodes and is typically bound to the fan system nodes.	
			<b>State</b>	<b>Meaning</b>
			OFF	The indoor air quality is acceptable
			ON	The indoor air quality is not acceptable and additional outdoor air is needed to bring it back to acceptable
NUL	The economizer for this node has not been configured or there is no sensor configured or the only configured sensor has failed.			
MonSensorOut	AV-1150	AV	Monitor sensor. This allows an unused analog input to be used as a generic network accessible value monitor. -3.399999952144364E38 ≤range ≤3.399999952144364E38	
MonSwOut	AV-1539	AV	Monitor switch status. This allows an unused binary input to be used as a generic network accessible digital status monitor.	
			<b>State</b>	<b>Meaning</b>
			OFF	inactive
			ON	active
NUL	not configured			
ODHumOut	AV-1151	AV	Outdoor air relative humidity 0 ≤ range ≤ 100 %	
ODTempOut	AV-1152	AV	Outdoor air temperature -40 ≤range ≤122F	
PeriphHtgPosOut	AV-1153	AV	Peripheral heat modulating valve position. 0 ≤range ≤100%	
PerphHtgStgsOut	AV-1154	AV	Number of active peripheral heating stages. 0 ≤range ≤1	
ReheatPosOut	AV-1155	AV	Reheat commanded control position. -163% ≤range ≤163%	
ReheatStgsOut	AV-1556	AV	Number of active heating coil stages. 0 ≤range ≤3	
DischargeTempOut	AV-1541	AV	Discharge air temperature setpoint -49 ≤range ≤233.6 F Sen Delta = 0.07 F	
<b>Sbus Sensors</b>				
ZioTempOut	AV-1157	AV	Calibrated Zio wall module temperature value. Output = SbusValue + CfgZioWallModTempOffset 30 ≤range ≤110F	
ZioRhOut	AV-1158	AV	Calibrated Zio wall module RH value Output = SbusValue + nciWallModZio.RhOffset 0 ≤range ≤100%	
C7400TempOut	AV-1159	AV	Calibrated C7400s temperature value Output = SbusValue + nciSbusSnsr.TempOffset -40 ≤range ≤150F	
C7400RhOut	AV-1560	AV	Calibrated C7400s RH value Output = SbusValue + nciSbusSnsr.RhOffset 0 ≤range ≤100%	

Object Name	Object Type/ID	Net Data Type	Description																								
SensorOccOut	AV-1161	AV	<p>OccSensorOut is an output showing the current state of the hard wired occupancy sensor. The valid enumerated states are listed below:</p> <table border="1"> <thead> <tr> <th>State</th> <th>Meaning</th> </tr> </thead> <tbody> <tr> <td>0 Occ</td> <td>The space is occupied</td> </tr> <tr> <td>1 UnOCC</td> <td>The space is not occupied</td> </tr> <tr> <td>255 Null</td> <td>The occupancy sensor is not configured</td> </tr> </tbody> </table>	State	Meaning	0 Occ	The space is occupied	1 UnOCC	The space is not occupied	255 Null	The occupancy sensor is not configured																
State	Meaning																										
0 Occ	The space is occupied																										
1 UnOCC	The space is not occupied																										
255 Null	The occupancy sensor is not configured																										
<p><b>ModeShareOut, ReheatCmdOut and PeriphCmdOut:</b> In some cases a sending node (master VAV controller) with a wall module may be used to control the Damper, ReHeat and Peripheral heat of one or more other receiving nodes (satellite VAV controllers) that do not have a wall module. To use this feature:</p> <ul style="list-style-type: none"> <li>All nodes involved must be configured to have the same kind of ReHeat via ReHeatType.</li> <li>The satellite receiving nodes must have FlowControlType set to ShareWallModule.</li> <li>The satellite receiving nodes must have the network input objects bound to network output objects of a node having a wall module. The following objects would be bound:</li> </ul> <table border="0"> <thead> <tr> <th>Source device</th> <th></th> <th>Destination device</th> </tr> </thead> <tbody> <tr> <td>1. <u>ModeShareOut</u></td> <td>Bind to</td> <td><u>ModeShareIn</u></td> </tr> <tr> <td>2. <u>ReheatStgsOut</u></td> <td>Bind to</td> <td><u>ReheatStgShareIn</u></td> </tr> <tr> <td>3. <u>ReheatCmdOut</u></td> <td>Bind to</td> <td><u>ReheatCmdIn</u></td> </tr> <tr> <td>4. <u>TempFlowCmdOut</u></td> <td>Bind to</td> <td><u>TempFlowCmdIn</u></td> </tr> <tr> <td>5. <u>EffectOccOut</u></td> <td>Bind to</td> <td><u>EffectOccIn</u></td> </tr> <tr> <td>6. <u>PerphHtgStgsOut</u></td> <td>Bind to</td> <td><u>PeriphStgIn</u></td> </tr> <tr> <td>7. <u>PeriphCmdOut</u></td> <td>Bind to</td> <td><u>PeriphCmdIn</u></td> </tr> </tbody> </table>				Source device		Destination device	1. <u>ModeShareOut</u>	Bind to	<u>ModeShareIn</u>	2. <u>ReheatStgsOut</u>	Bind to	<u>ReheatStgShareIn</u>	3. <u>ReheatCmdOut</u>	Bind to	<u>ReheatCmdIn</u>	4. <u>TempFlowCmdOut</u>	Bind to	<u>TempFlowCmdIn</u>	5. <u>EffectOccOut</u>	Bind to	<u>EffectOccIn</u>	6. <u>PerphHtgStgsOut</u>	Bind to	<u>PeriphStgIn</u>	7. <u>PeriphCmdOut</u>	Bind to	<u>PeriphCmdIn</u>
Source device		Destination device																									
1. <u>ModeShareOut</u>	Bind to	<u>ModeShareIn</u>																									
2. <u>ReheatStgsOut</u>	Bind to	<u>ReheatStgShareIn</u>																									
3. <u>ReheatCmdOut</u>	Bind to	<u>ReheatCmdIn</u>																									
4. <u>TempFlowCmdOut</u>	Bind to	<u>TempFlowCmdIn</u>																									
5. <u>EffectOccOut</u>	Bind to	<u>EffectOccIn</u>																									
6. <u>PerphHtgStgsOut</u>	Bind to	<u>PeriphStgIn</u>																									
7. <u>PeriphCmdOut</u>	Bind to	<u>PeriphCmdIn</u>																									
ModeShareOut	AV-1162	AV	<p>Master Node Status</p> <p>0 - Startup wait</p> <p>1 - Heat</p> <p>2 - Cool</p> <p>3 - Reheat</p> <p>4 - Morn_Warm</p> <p>5 - Night Purge</p> <p>6 - Pressurize</p> <p>7 - Depressurize</p> <p>8 - Trackflow</p> <p>9 - Manual Damper Position</p> <p>10 - Manual Flow</p> <p>11 - Freeze Protect</p> <p>12 - Factory Test.</p> <p>Not supported</p> <p>13 - IO Test</p> <p>Not Supported.</p> <p>14 - Float out sync</p> <p>Not Supported.</p> <p>15 - Disabled</p> <p>Not Supported.</p> <p>16 - Manual</p> <p>Not Supported.</p> <p>17 - Emerg Command Purge</p> <p>18 - Emerg Command Shutdown</p> <p>19 - Htg &amp; Clg disabled.</p> <p>20 - Fan only Notes:</p> <p>Notes:</p> <ol style="list-style-type: none"> <li>Mode 6 (Pressurize) and Mode 7 (Depressurize) are ignored if the controller is disabled. Use network input EmergCmdIn to override a slave controller in the disabled mode.</li> </ol>																								

Object Name	Object Type/ID	Net Data Type	Description
ReheatStgsShareIn		AV	indicates the number of stages that should be turned on in the receiving nodes $0 \leq \text{range} \leq 3$
ReheatCmdOut	AV-1163	AV	indicates the amount of modulating ReHeat that should be turned on in the receiving nodes. $0 \leq \text{range} \leq 100\%$
TempFlowCmdOut	AV-1164	AV	Output command of the temperature control loop in terms of percentage (%) of flow capacity mapped to the minimum - maximum flow range (zero percent as minimum flow and 100% as maximum flow). $0 \leq \text{range} \leq 100\%$
EffectOccln	AV-1208	AV	Effective occupancy 0: Occupied 1: Unoccupied 2: Bypass 3: Standby
PeriphStgIn	AV-1209	AV	indicates the number of peripheral heat stages that should be turned on in the receiving nodes $0 \leq \text{range} \leq 1$
PeriphCmdOut	AV-1165	AV	indicates the amount of modulating peripheral heat that should be turned on in the receiving nodes. $0 \leq \text{range} \leq 100\%$
SpaceCO2Out	AV-1166	AV	Space CO <sub>2</sub> concentration. $0 \leq \text{range} \leq 5000$ PPM
SpaceHumOut	AV-1167	AV	Space relative humidity. $0 \leq \text{range} \leq 100\%$
SpaceTempOut	AV-1168	AV	The space temp value available to the network $14 \leq \text{range} \leq 122$ F
StatisPressOut	AV-1169	AV	Building or Duct static pressure. This is a data value obtained from a spare local input. It is typically network connected to a central VAV fan control. $-1.3433e36 \leq \text{range} \leq 1.3433e36$ inWc
SupplyTempOut	AV-1170	AV	Duct in cooling supply temperature. $32 \leq \text{range} \leq 212$ F
TerminalLoadOut	AV-1171	AV	The effective loading on the controller. A positive value indicates a cooling load and a negative value will indicate that there is a heating load. The Terminal Load calculation is controlled by CfgCZSType Conventional calculation uses the PID output of heating and cooling controls. When the controller is switched to the heating mode, the Terminal load $\leq 0$ . $-160\% \leq \text{range} \leq 160\%$ CZS calculation uses the Proportional output of heating and cooling controls. When the controller is switched to the heating mode, the Terminal Load continues to report both heating and cooling demand. The terminal load absolute value is truncated at 100% $-100\% \leq \text{range} \leq 100\%$
<b>Tod Event:</b> BACnet object for scheduled events			
TodEventCurrStateOut	AV-1172	AV	current event state in the controller 0: Occupied 1: Unoccupied 2: Bypass 3: Standby

Object Name	Object Type/ID	Net Data Type	Description								
TodEventNextStateOutput	AV-1173	AV	scheduled next state in the controller. 0: Occupied 1: Unoccupied 2: Bypass 3: Standby 255: Null								
TodEventTimeToNextStateOut	AV-1174	AV	scheduled time to the next state in the controller $0 \leq \text{range} \leq 11520$ minutes								
VAV Controller status: Use the application UnitStatus to add this object to your BACnet controller.											
UnitHeatOutputPrimaryOut	AV-1175	AV	Reports the current percentage of ReHeat stages or modulating ReHeat turned on. When ReHeat is not configured, UnitHeat is set to Invalid. 0 - 100%								
UnitHeatOutputSecondaryOut	AV-1176	AV	Reports the current percentage of peripheral Heat demand. When peripheral Heat is not configured this value is set to Invalid. 0 - 100%								
UnitCoolOutputOut	AV-1177	AV	Reports the current percentage of cooling air delivered to the zone. 0 - 100%								
UnitFanOutputOut	AV-1178	AV	If a fan is configured as one speed, This value is 100 percent, when the fan is running and is zero when the fan is not running. If a modulating fan is configured, reports the fan speed in percentage. 0 - 100%								
UnitInAlarmOut	AV-1530	AV	0 - Means there is no application alarm. Not 0 - Means there is an application alarm								
VelSenPress	AV-1179	AV	The calibrated value of the cooling airflow pressure sensor. The sensor value minus the offset value. $-0.0494 \leq \text{range} \leq 1.5833$ inWc								
WindowOut	AV-1533	AV	This network output allows the <b>hard wired window sensor</b> to be used by other nodes on the network. The valid states are described below: <table border="1" data-bbox="654 1249 1208 1413"> <thead> <tr> <th>State</th> <th>Meaning</th> </tr> </thead> <tbody> <tr> <td>OFF</td> <td>Window closed</td> </tr> <tr> <td>ON</td> <td>Window open</td> </tr> <tr> <td>NUL</td> <td>Window sensor not configured</td> </tr> </tbody> </table>	State	Meaning	OFF	Window closed	ON	Window open	NUL	Window sensor not configured
State	Meaning										
OFF	Window closed										
ON	Window open										
NUL	Window sensor not configured										

Configuration Parameters

Table 25: Configuration Parameters

Object Name	Object Type/ID	Net Data Type	Default Val	Description
<b>Balance Setpoints</b>				
BalBoxZeroOffset	AV-1259	AV	0	Airflow pressure sensor zero calibration offset. This value is <b>subtracted</b> from the sensor input. Precision: 1



Object Name	Object Type/ID	Net Data Type	Default Val	Description
BalKFactorOffset	AV-1260	AV	0	VAV Box cooling air K factor calibration parameter. This factor is used by the Balancing tool to increment the factory K factor setting. The Offset value is <b>added</b> to the factory value. Precision: 0
BalMaxMeasFlowAct	AV-1261	AV	1000	The actual cooling flow measured at the max flow setting during the two point airflow balancing process. (optional) 0 ≤ range ≤ 138850 cfm Notes: This value is set by the flow balancing tool. Set the value to 1000 to disable two point calibration. Precision: 0
BalMaxMeasFlowSpt	AV-1262	AV	1000	The actual cooling flow maximum setpoint during the two point airflow balancing process. (optional) 0 ≤ range ≤ 138850 cfm Notes: This value is set by the flow balancing tool. Set the value to 1000 to disable two point calibration. Precision: 0
BalMinMeasFlowAct	AV-1263	AV	0	The actual cooling flow measured at the min flow setting during the two point airflow balancing process. (optional) 0 ≤ range ≤ 138850 cfm Notes: This value is set by the flow balancing tool. Set the value to 0 to disable two point calibration. Precision: 0
BalMinMeasFlowSpt	AV-1264	AV	0	The actual cooling flow minimum setpoint during the two point airflow balancing process. (optional) 0 ≤ range ≤ 138850 cfm Notes: This value is set by the flow balancing tool. Set the value to 0 to disable two point calibration. Precision: 0
<b>CO<sub>2</sub>Ventilation:</b> Configuration for indoor air quality ventilation control.				
CfgCO2VentLowSP	AV-1265	AV	400	Low Room CO <sub>2</sub> level associated with the flow setting MinFlowSetpt. range: 300 to 1200 ppm default value: 400 ppm Precision: 0
CfgCO2VentHighSP	AV-1266	AV	900	High Room CO <sub>2</sub> level associated with the highest flow reset setting: MinFlowSetpt + FractionOfMaxAirFlow*MaxFlowSetpt range: 300 to 1200 ppm default value: 900 ppm Precision: 0
CfgCO2VentFractionOfMaxAirFlow	AV-1267	AV	0.0	Fraction of maximum airflow added to the minimum airflow setpoint while coordinating CO <sub>2</sub> with the effective airflow setpoint. 0 ≤ range ≤ 1.0 Precision: 3 Notes: Set this value to zero to disable CO <sub>2</sub> ventilation.
<b>Cooling</b>				
CfgCoolingTR	AV-1269	AV	3	Cooling throttling range 2 ≤ range ≤ 30 ΔF Precision: 0
CfgCoolingIT	AV-1270	AV	4000	Cooling integral time 0 ≤ range ≤ 9000 sec Precision: 0

Object Name	Object Type/ID	Net Data Type	Default Val	Description																								
CfgCoolingDT	AV-1271	AV	0	Cooling derivative time $0 \leq \text{range} \leq 9000 \text{ sec}$ Precision: 0																								
DLCShiftSetpt	AV-1508	AV	3	Demand limit shed setpoint shift. The room space temperature cooling setpoint is shifted up and the heating setpoint is shifted down by this value during a DLC active event. $0 \leq \text{range} \leq 10 \Delta F$ Precision: 1																								
<b>Commercial Zoning System Configuration</b>																												
CfgCZSType	AV-1268	AV	0	CZS type 0: use conventional zone terminal load calculation. 1: use CZS zone terminal load calculation. Notes: Refer to TerminalLoadOut for details on terminal load calculation.																								
CfgDuctArea	AV-1288	AV	0.5454	The area of the cooling duct where the flow sensor is installed. <table border="1" data-bbox="789 814 1084 1333"> <thead> <tr> <th>Duct Dia (in)</th> <th>Area (sq ft)</th> </tr> </thead> <tbody> <tr><td>2</td><td>0.0218</td></tr> <tr><td>4</td><td>0.0873</td></tr> <tr><td>6</td><td>0.1963</td></tr> <tr><td>8</td><td>0.3491</td></tr> <tr><td>10</td><td>0.545</td></tr> <tr><td>12</td><td>0.7854</td></tr> <tr><td>14</td><td>1.069</td></tr> <tr><td>18</td><td>0.7671</td></tr> <tr><td>20</td><td>2.1817</td></tr> <tr><td>22</td><td>2.6398</td></tr> <tr><td>24</td><td>3.1416</td></tr> </tbody> </table> $0 < \text{range} \leq 100 \text{ sqFt}$ Precision: 3	Duct Dia (in)	Area (sq ft)	2	0.0218	4	0.0873	6	0.1963	8	0.3491	10	0.545	12	0.7854	14	1.069	18	0.7671	20	2.1817	22	2.6398	24	3.1416
Duct Dia (in)	Area (sq ft)																											
2	0.0218																											
4	0.0873																											
6	0.1963																											
8	0.3491																											
10	0.545																											
12	0.7854																											
14	1.069																											
18	0.7671																											
20	2.1817																											
22	2.6398																											
24	3.1416																											
<b>Fan</b>																												
CfgFanType	AV-1289	AV	0	VAV box fan configuration 0: No Fan 1: Series Fan, fan runs when occupied or standby (When nciOccStandby = 1). A Series Fan configuration should be combined with pressure independent airflow control. This is necessary in order to avoid energy waste by dumping uncontrolled primary air through the induction (return air) inlet. If the Mode is: Occ, (Standby AND CfgOccStandby = 1), Morn Warmup, Reheat, Heat with demand for heating; Or NightPurge then the Fan Speed is ON 2: Parallel Fan, temperature control, fan runs with reheat																								

Object Name	Object Type/ID	Net Data Type	Default Val	Description
				<p>3: Parallel Fan, airflow control, fan runs intermittently based on primary airflow and occupancy.                      4: Parallel Fan, Speed control (inverse to cooling demand or constant volume)                      If the Effective Occupancy is:                      Occ Standby Bypass                      Unoccupied with a demand calling for cool and:                      No Htg Demand                      then the Fan Speed is:                      Inversely proportional to the "demand for cooling" and varies between 0 and 100%.                      If the Mode is:                      Morn Warmup, Reheat, Heat with demand for heating;                      Or NightPurge                      then the Fan Speed is (100%)                      Else FanSpeed is: 0%.                      Refer to Appendix A for fan control details.</p>
CfgFanEnableFlow	AV-1290	AV	0	<p>Parallel fan start threshold.                      During the occupied mode, the fan is started when the primary air percent of max flow is less than or equal to FanEnableFlow percent.  <math>0 \leq \text{range} \leq 100\%</math>                      Precision: 1 Notes:                      This setpoint applies only to the fan type Parallel airflow control. A percent value is used to facilitate fan control independent of the zone terminal max airflow setting.                      There is a 5% hysteresis value for turning off the fan.</p>

Object Name	Object Type/ID	Net Data Type	Default Val	Description
<b>Flow Loop</b>				
CfgFlowType	AV-1307	AV	0	<p>Flow Control Type</p> <p>0 – Normal, The flow is controlled to satisfy the temperature control algorithm.</p> <p>1 – Flow Tracking, The temperature control is turned off and the airflow set point equals the sum FlowTrackIn (AV-1189) and TrackModeOffset. This feature is used to balance the flow between several input vav boxes and one exhaust vav box in a room. If a non zero value is assigned to TrackModeOffset, then the room is pressurized or de pressurized.</p> <p>Notes:</p> <p>Flow Tracking ignores window open flow settings. Flow Tracking ignores morning warmup configuration. Flow Tracking follows emergency command flow settings.</p> <p>2 – ShareWall Module, The temperature control loop is turned off and the flow is controlled by the wall module at another master node. In this case (ModeShareIn, ReheatStgsShareIn, ReheatCmdIn, TempFlowCmdIn, EffectOccln, PeriphStgIn and PeriphCmdIn) is bound to (ModeShareOut, ReheatCmdOut, PeriphCmdOut and TempFlowCmdOut) of the master node and the information received in (ModeShareIn, ReheatStgsShareIn, ReheatCmdIn, TempFlowCmdIn, EffectOccln, PeriphStgIn and PeriphCmdIn) is used to control the airflow. The master node has the temperature sensor connected to it and controls the space temperature by its own damper and the other dampers of all nodes bound to it. This feature is used when:</p> <p>Only one temperature sensor is used in a large area to control several nodes.</p> <p>There is a need to reprogram multiple satellite controllers based on flexible floor plans. Each controller is fitted with a wall module and the units configured as a ShareWallModule with a valid 'ModeShareIn, ReheatStgsShareIn, ReheatCmdIn, TempFlowCmdIn, EffectOccln, PeriphStgIn and PeriphCmdIn' network connection respond as satellites of the master controller providing 'ModeShareOut, ReheatCmdOut, PeriphCmdOut and TempFlowCmdOut' data.</p>

Object Name	Object Type/ID	Net Data Type	Default Val	Description																						
CfgPressureDependentFlow	AV-1308	AV	0	<p>Enable pressure dependent control logic in the airflow control loop. Pressure dependent control does not require an airflow sensor.</p> <p>0 – pressure independent is implemented using a cascaded control algorithm. The temperature control algorithm specifies the desired airflow and the cascaded flow control algorithm measures and controls the airflow to the desired airflow set point. The airflow is independent of the supply air pressure. An airflow sensor is required to measure the actual airflow.</p> <p>1 – pressure dependent is implemented using the space temperature to control the damper Position directly. The airflow is dependent on the supply air pressure. The airflow sensor is not used to control airflow.</p> <p>Notes: Series fan zone terminals require pressure independent airflow control. This is necessary in order to avoid dumping the primary air through the induction (return air) inlet. If pressure dependent control is enabled, the Tool must set AV_AlarmInh0,AV_AlarmInh1...AV_AlarmInh15 in order to disable the alarm ID associated with the alarm state on-board pressure sensor is open or shorted.</p>																						
CfgFlowTR	AV-1209	AV	180	<p>Throttling range. default value is 180 fpm <math>0 \leq \text{range} \leq 5000</math> fpm Precision: 0</p>																						
CfgFlowDeadBand	AV-1310	AV	20	<p>The flow control deadband. This is configured based on the damper motor speed. Since airflow control is implemented in face velocity, the deadband is in feet per minute.</p> <p>Floating Actuators</p> <table border="1"> <thead> <tr> <th>Motor Speed (sec)</th> <th>Deadband (fpm)</th> </tr> </thead> <tbody> <tr> <td>15</td> <td>125</td> </tr> <tr> <td>30</td> <td>65</td> </tr> <tr> <td>60</td> <td>30</td> </tr> <tr> <td>90</td> <td>20</td> </tr> <tr> <td>180</td> <td>20</td> </tr> <tr> <td>420</td> <td>20</td> </tr> </tbody> </table> <p>Proportional Actuators</p> <table border="1"> <thead> <tr> <th>Model Number</th> <th>Deadband (fpm)</th> </tr> </thead> <tbody> <tr> <td>ML7174</td> <td>460</td> </tr> <tr> <td>ML7284</td> <td>260</td> </tr> <tr> <td>ML7475</td> <td>330</td> </tr> </tbody> </table>	Motor Speed (sec)	Deadband (fpm)	15	125	30	65	60	30	90	20	180	20	420	20	Model Number	Deadband (fpm)	ML7174	460	ML7284	260	ML7475	330
Motor Speed (sec)	Deadband (fpm)																									
15	125																									
30	65																									
60	30																									
90	20																									
180	20																									
420	20																									
Model Number	Deadband (fpm)																									
ML7174	460																									
ML7284	260																									
ML7475	330																									

Object Name	Object Type/ID	Net Data Type	Default Val	Description														
				<table border="1"> <tr> <td>MN7505</td> <td>45</td> </tr> <tr> <td>MN7510</td> <td>45</td> </tr> </table> <p>Notes: Proportional actuators not recommended for pressure independent airflow control. <math>0 \leq \text{range} &lt; \text{TR} \leq 5000 \text{ fpm}</math> Precision: 0</p>	MN7505	45	MN7510	45										
MN7505	45																	
MN7510	45																	
CfgFlowMaxAOChng	AV-1311	AV	1.15	<p>The flow control maximum analog output change per second. This is configured based on the damper motor speed.</p> <table border="1"> <thead> <tr> <th>Motor Speed (sec)</th> <th>maxAOchg per second</th> </tr> </thead> <tbody> <tr> <td>15</td> <td>1.15</td> </tr> <tr> <td>30</td> <td>1.15</td> </tr> <tr> <td>60</td> <td>1.15</td> </tr> <tr> <td>90</td> <td>1.15</td> </tr> <tr> <td>180</td> <td>0.56</td> </tr> <tr> <td>420</td> <td>0.24</td> </tr> </tbody> </table> <p><math>0.01 \leq \text{range} \leq 100\%</math> Precision: 3</p>	Motor Speed (sec)	maxAOchg per second	15	1.15	30	1.15	60	1.15	90	1.15	180	0.56	420	0.24
Motor Speed (sec)	maxAOchg per second																	
15	1.15																	
30	1.15																	
60	1.15																	
90	1.15																	
180	0.56																	
420	0.24																	
CfgFlowMinAOChng	AV-1312	AV	0.11	<p>Minimum output change per second. default value is 0.11 pct <math>0 \leq \text{range} \leq 100\%</math> Precision: 3</p>														
CfgEnableLowFlowAlarm	AV-1313	AV	1	<p>Enable low airflow alarm. 0: disable low airflow alarm 1: enable low airflow alarm</p>														
CfgFilterFlow	AV-1314	AV	0	<p>Airflow low pass (10 sec time constant) filter enable. Warning: Enable filter only when the pressure pickup is installed in a turbulent airflow environment with unstable airflow control issues. 0: filter disabled 1: filter enabled Notes: Set CfgFlowDeadBand (AV-1310) = 30 fpm when filter enabled</p>														
<b>Flow SetPoint</b>																		
CfgStbyMinFlowPos	AV-1315	AV	0	<p>VAV Box standby mode of operation minimum flow setpoint in damper position percent. Applies only to pressure dependent control mode. <math>0 \leq \text{range} \leq \text{MaxFlowPos}</math> Precision: 1</p>														
CfgUnOcMinFlowPos	AV-1316	AV	0	<p>VAV Box unoccupied mode of operation minimum flow setpoint in damper position percent. Applies only to pressure dependent control mode. <math>0 \leq \text{range} \leq \text{MaxFlowPos}</math> Precision: 1</p>														

Object Name	Object Type/ID	Net Data Type	Default Val	Description
CfgMinFlowPos	AV-1317	AV	15	Zone terminal minimum cooling flow setpoint during the occupied mode of operation. Applies only to pressure dependent control mode or when a pressure independent airflow sensor fails. 0 ≤ range ≤ MaxFlowPos Precision:1
CfgMaxFlowPos	AV-1318	AV	60	VAV Box Maximum Cooling flow value in damper position percent. Applies only to pressure dependent control mode or when a pressure independent airflow sensor fails. 0 ≤ range ≤ 100% Precision:1
CfgReheatFlowPos	AV-1319	AV	20	VAV Box Reheat cooling air value in damper position percent. The cooling air damper will be at the ReheatPos at maximum reheat capacity. 0 ≤ range ≤ MaxFlowPos Precision: 1
CfgEmergPress	AV-1320	AV	100	Emergency pressurization setting as a percent of maximum flow. 0 ≤ range ≤ 100% Precision: 1
CfgEmergDePress	AV-1321	AV	0	Emergency depressurization setting as a percent of maximum flow. 0 ≤ range ≤ 100% Precision: 1
CfgEmergPurge	AV-1322	AV	50	Emergency purge setting as a percent of maximum flow. 0 ≤ range ≤ 100% Precision: 1
CfgWarmup	AV-1323	AV	50	Warmup setting as a percent of maximum flow. 0 ≤ range ≤ MaxFlowPos Precision: 1
CfgNightPurge	AV-1324	AV	50	Night purge setting as a percent of maximum flow. 0 ≤ range ≤ MaxFlowPos Precision: 1
CfgWindowOpen	AV-1325	AV	0	Window open damper position. When a window is open, airflow control is disabled, the flow damper is set to WindowOpenPos until the space temperature drops below the temperature set point. 0 ≤ range ≤ MaxFlowPos Precision: 1
CfgTrackModeOffset	AV-1326	AV	0	Flow tracking offset. This value is used when the FlowControlType = FlowTracking The temperature control is turned off and the airflowSP = FlowTrackIn (AV-1189) + TrackModeOffset -138850 ≤ range ≤ 138850 cfm Precision:0 Notes: The current version of Stryker Tool does not support negative values for InternalDataType = cfm
CfgHtgLockout	AV-1374	AV	0	Future reheat lockout setting. Reheat is locked out when the airflow less than this value.
CfgFreshAirRequired	AV-1327	AV	0	This is the amount of fresh air required for this zone during scheduled occupancy. 0 ≤ range ≤ 138850 cfm Precision:0

Object Name	Object Type/ID	Net Data Type	Default Val	Description						
<b>Heating</b>										
CfgReheatConfig	AV-1328	AV	0	Reheat output configuration. Used to Tune the heating PID control loop and set the stages of the Cyclcr. 0: cooling only 1: one stage reheat 2: two stage reheat 3: three stage reheat 10: modulating reheat output range: 0, 1, 2, 3, 10						
CfgRhModDatCntrl	AV-1509	AV	0	Discharge Air control of the modulating Reheat. 0: Normal (TR75 = A_rH) sequence for modulating Reheat. 1: Discharge Air (TR75 = dA_rH) control sequence. Reheat control is modulated to maintain discharge air temp (reset upto DischargeMaxSp and then damper position is varied from min position up to ReheatFlowMaxSetPt.						
CfgReheatControlConfig	AV-1329	AV	1	Reheat airflow control 0: The Reheat airflow or damper position is set to a fixed position <table border="1" data-bbox="792 892 1388 1018"> <thead> <tr> <th>Flow Control</th> <th>Fixed Reheat Position</th> </tr> </thead> <tbody> <tr> <td>Pressure dependent</td> <td>CfgReheatFlowPos</td> </tr> <tr> <td>Pressure independent</td> <td>CfgReheatFlowSetpt</td> </tr> </tbody> </table> 1: ReHeat airflow and damper Position varies (between minimum position and fixed reheat) according to the temperature control loop.	Flow Control	Fixed Reheat Position	Pressure dependent	CfgReheatFlowPos	Pressure independent	CfgReheatFlowSetpt
Flow Control	Fixed Reheat Position									
Pressure dependent	CfgReheatFlowPos									
Pressure independent	CfgReheatFlowSetpt									
CfgHeatingSequence	AV-1330	AV	0	Heating sequence. 0: reheat only 1: peripheral then reheat. 2: reheat then peripheral 3: reheat & peripheral then reheat airflow. At the end of the sequence, reheat airflow is modulated with heating demand or constant based on the CfgReheatControlConfig value. 0: fixed airflow at maxReheatFlow 1: modulated airflow up to maxReheatFlow Note: Sequence #3 is not appropriate for electric reheat coils. 4: peripheral only.						
CfgPeripheralMinimumPosition	AV-1331	AV	0	sets the minimum peripheral Heat modulating valve Position. This feature allows the user to maintain flow in pipes that may otherwise freeze. If the outdoor air temperature value is connected to the zone terminal, the minimum position is active when the outdoor air temperature is below 40F. 0 ≤ range ≤ 100% Precision: 1						



Object Name	Object Type/ID	Net Data Type	Default Val	Description												
CfgMorningWarmup Type	AV-1332	AV	1	<p>The controller may receive a morning warm-up command from the air equipment control so that the control will change to operate with warm supply air. The morning warm-up types supported are listed below:</p> <p>0: MornMixedAir -Warm air is being supplied via the duct, the temperature control is turned off, and either the damper Position or airflow is commanded to a configurable set point.</p> <p>1: MornWarmAir-Warm air is being supplied via the duct and the temperature control is reverse acting. ReHeat may be turned on in this configuration to supply warmer air to the space.</p> <p>Reheat enabled Peripheral heat enabled</p> <p>2: MornWarmNoReheat-Warm air is being supplied via the duct and the temperature control is reverse acting. Reheat disabled Peripheral heat enabled</p>												
CfgHeatingTR	AV-1333	AV	3	<p>Heating throttling range</p> <table border="1"> <thead> <tr> <th>Type</th> <th>TR (F)</th> </tr> </thead> <tbody> <tr> <td>mod</td> <td>5</td> </tr> <tr> <td>1 stage</td> <td>3</td> </tr> <tr> <td>2 stage</td> <td>4</td> </tr> <tr> <td>3 stage</td> <td>7</td> </tr> <tr> <td>4 stage</td> <td>8</td> </tr> </tbody> </table> <p>2 ≤ range ≤ 30 ΔF                      Precision: 0 Notes                      The Tool will set the TR based on the value of the field "CfgReheatConfig".</p>	Type	TR (F)	mod	5	1 stage	3	2 stage	4	3 stage	7	4 stage	8
Type	TR (F)															
mod	5															
1 stage	3															
2 stage	4															
3 stage	7															
4 stage	8															
CfgHeatingIT	AV-1334	AV	3100	<p>Heating integral time</p> <table border="1"> <thead> <tr> <th>Type</th> <th>IT (sec)</th> </tr> </thead> <tbody> <tr> <td>mod</td> <td>2400</td> </tr> <tr> <td>1 stage</td> <td>3100</td> </tr> <tr> <td>2 stage</td> <td>2500</td> </tr> <tr> <td>3 stage</td> <td>1650</td> </tr> <tr> <td>4 stage</td> <td>1200</td> </tr> </tbody> </table> <p>0 ≤ range ≤ 5000 sec                      Precision: 0 Notes                      The Tool will set the IT based on the value of the field "CfgReheatConfig".</p>	Type	IT (sec)	mod	2400	1 stage	3100	2 stage	2500	3 stage	1650	4 stage	1200
Type	IT (sec)															
mod	2400															
1 stage	3100															
2 stage	2500															
3 stage	1650															
4 stage	1200															
CfgHeatingDT	AV-1335	AV	0	<p>Modulating heating derivative time 0 ≤ range ≤ 9000 sec                      Precision: 0</p>												

Object Name	Object Type/ID	Net Data Type	Default Val	Description
CfgKFactor	AV-1336	AV	1400	VAV Box cooling air K factor used to calculate the flow value. Refer to Appendix K for specific values $0 < \text{range} \leq 10000$ $K = \text{Airflow} / (Pv)^{1/2}$ Pv: differential flow press (InWc) Airflow: airflow (CFM) Notes: The K factor must be configured before starting the optional two point airflow balancing procedure. The K factor is obtained from the terminal box manufacturer. Do not change the K value after the VAV box has been balanced using the two point method. Never set the K value to invalid or zero.
CfgMaxFlowSetpt	AV-1547	AV	1000	VAV Box Maximum Cooling airflow value in cfm $0 \leq \text{range} \leq 138850$ cfm Precision: 0
CfgReheatFlowSetpt	AV-1550	AV	300	VAV Box Maximum reheat airflow setpoint. $0 \leq \text{range} \leq 138850$ cfm Precision: 0
CfgMinFlowSetpt	AV-1548	AV	200	Zone terminal minimum cooling flow setpoint during the occupied mode of operation. $0 \leq \text{range} \leq 138850$ cfm Precision: 0
CfgMinFlowUnOccSP	AV-1545	AV	0	Zone terminal minimum cooling flow setpoint during the unoccupied mode of operation. $0 \leq \text{range} \leq 138850$ cfm Precision: 0
CfgStbyMinFlowSP	AV-1549	AV	100	VAV Box Minimum flow setpoint during the standby mode of operation. $0 \leq \text{range} \leq 138850$ cfm Precision: 0
CfgOccSensorOp	AV-1485	AV	2	Occupancy sensor operation 1: UnoccupiedCleaningCrew, When scheduled to be unoccupied and the occupancy sensor is active, switch to standby for the comfort of the cleaning crew. 2: ConferenceRoom, When scheduled to be unoccupied stay unoccupied independent of the occupancy sensor activity. During scheduled occupancy, occupancy sensor changes mode between standby and occupied. 3: UnoccupiedTenant, When scheduled to be unoccupied and the occupancy sensor is active, switch to occupied for the comfort of the tenant. Notes If an occupancy sensor is configured and the space is scheduled for occupied and the occupancy sensor is inactive, the mode switches to standby. Manual override commands have priority over the schedule and the occupancy sensor. Occupancy Sensor Behavior 1 – No occupancy detected (inactive) 0 – Occupancy detected (active)

Object Name	Object Type/ID	Net Data Type	Default Val	Description
CfgOccStandby	AV-1488	AV	0	Standby mode occupancy interpretation. 0: Standby considered unoccupied for Fan operation and auxiliary output. 1: Standby considered occupied for Fan operation and auxiliary output.
CfgPwrUpDisable	AV-1551	AV	10	Controller power up disable time. Local logical digital outputs are disabled for a fixed time at power up. Emergency mode bypasses the power up disable. 1 ≤ range ≤ 300 sec Precision: 0
<b>Cooling Recovery</b>				
CfgRecovMaxClgRamp	AV-1491	AV	6	Max cooling setpoint ramp 0 ≤ range ≤ 36 ΔF/hr Precision: 3
CfgRecovMinClgRamp	AV-1492	AV	2	Min cooling setpoint ramp Cooling recovery rate when an outdoor air temperature sensor value is not available. 0 ≤ range ≤ 36 ΔF/hr Precision: 3
CfgRecovOTMxClgRmp	1489	AV	70	Outdoor air temperature at the max cooling ramp -30 ≤ range ≤ 120 F Precision: 1
CfgRecovOTMnClgRmp	AV-1490	AV	90	Outdoor air temperature at the min cooling ramp -30 ≤ range ≤ 120 F Precision: 1
<b>Heating Recovery</b>				
CfgRecovMaxHtgRamp	AV-1496	AV	8	Max heating setpoint ramp 0 ≤ range ≤ 36 ΔF/hr Precision: 3
CfgRecovMinHtgRamp	AV-1495	AV	2	Min heating setpoint ramp. Heating recovery rate when an outdoor air temperature sensor value is not available. 0 ≤ range ≤ 36 ΔF/hr Precision: 3
CfgRecovOTMxHtgRmp	AV-1493	AV	60	Outdoor air temperature at the max heating ramp -30 ≤ range ≤ 120 F Precision: 1
CfgRecovOTMnHtgRmp	AV-1494	AV	0	Outdoor air temperature at the min heating ramp -30 ≤ range ≤ 120 F Precision: 1
CfgSpSpcFrz	AV-1507	AV	46.4	Space freeze protection setpoint. The space heating setpoint is shifted to this value when a window is opened. -30 ≤ range ≤ 70 F Precision: 1
<b>Space Temperature Alarm</b>				
CfgSpcTempAlmHiLimit	AV-1518	AV	90	Space temperature occupied alarm high limit LoLimit < range ≤ 100F Precision: 1

Object Name	Object Type/ID	Net Data Type	Default Val	Description
CfgSpcTempAlmLoLimit	AV-1519	AV	50	Space Temperature occupied alarm low limit 40F ≤ range < HiLimit Precision: 1
CfgSpcTempAlmDelay	AV-1520	AV	30 min	Space Temp alarm disable delay from a change to occupied. 0 ≤ range ≤ 546 min Precision: 0
<b>Temperature Setpoints:</b> Room Temperature setpoints. 40 ≤ range ≤ 100F Precision: 1 unoccupied_heats ≤ standby_heat ≤ occupied_heats occupied_cool ≤ standby_cool ≤ unoccupied_cool				
OccupiedCoolSetpoint	AV-1337	AV	74	
StandbyCoolSetpoint	AV-1338	AV	76	
UnoccupiedCoolSetpoint	AV-1339	AV	85	
OccupiedHeatSetpoint	AV-1340	AV	70	
StandbyHeatSetpoint	AV-1341	AV	67	
UnoccupiedHeatSetpoint	AV-1342	AV	60	
Wall Module configuration common to Zio and Conventional				
CfgWallModBypassTime	AV-1500	AV	180	BypassTime is the time between the pressing of the override button at the wall module (or initiating Bypass via ManOccln) and the return to the original occupancy state. 0 ≤ range ≤ 1092 min Precision: 0 Notes: To disable bypass in Zio, set this value to zero.
CfgWallModUseWmStPt	AV-1497	AV	0	UseWallModStPt specifies the center set point temperature source when the effective occupancy is Occ. If UseWMStPt is 1, then, based on the type of set point knob configured, then "temporary" variables OccHeat and OccCool are changed as shown below: Type of SetPoint Direct OccHeat = WallModSetPt - ZEB / 2 OccCool = WallModSetPt + ZEB / 2 Offset OccHeat = OccHeat + WallModSetPt OccCool = OccCool + WallModSetPt 0 – Ignore Wall Module Setpt 1 – Use Wall Module SetPt Notes: The Wall Module center setpoint is active only when the effective occupancy is Occupied or Bypass.

Object Name	Object Type/ID	Net Data Type	Default Val	Description
CfgWallModLowSetPt	AV-1498	AV	-10	Low limit on wall module occupied center setpoint -10 ≤ range ≤ 100 Precision: 1 Notes: The center setpoint high & low limit are unit less since the center point value can be in F or ΔF. If you are using a Conventional Wall Module relative setpoint, the low limit must be greater than -10F. That is, a value of -10F is interpreted as -10F absolute.
CfgWallModHighSetPt	AV-1499	AV	100	High limit on the wall module occupied center setpoint. -10 ≤ range ≤ 100 Precision: 1 Notes: The center setpoint high & low limit are unit less since the center point value can be in F or ΔF. If you are using a Conventional Wall Module relative setpoint, the high limit must be less than +10F. That is, a value of +10F is interpreted as +10F absolute.
CfgWallModType	AV-1421	AV	2	Wall module type 0: None 1: Conventional Wall module(TR20) 2: Zio TR71 or TR75
CfgWallModMinHtgSetPt	AV-1376	AV	0	Low limit on occupied heating setpoint. 0F ≤ range ≤ MaxHtgSetPt Precision: 1
CfgWallModMaxHtgSetPt	AV-1378	AV	100	High limit on occupied heating setpoint. MinHtgSetPt ≤ range ≤ 100F Precision: 1
CfgWallModMinClgSetPt	AV-1377	AV	0	Low limit on occupied cooling setpoint. 0F ≤ range ≤ MaxClgSetPt Precision: 1
CfgWallModMaxClgSetPt	AV-1375	AV	100	High limit on occupied cooling setpoint. MinClgSetPt ≤ range ≤ 100F Precision: 1
Conventional Wall Module Configuration. Used by the Tool set the bypass override operation.				
CfgConvWallModOverrideType	AV-1420	AV	0	Override Type 0: Normal 1: Bypass Only 2: Disabled Note: The CfgWallModType = 1 (TR20) to enable the TR20 override push button.
<p>Zio Wall Module Config</p> <p>These configuration parameters are used by the Tool set Zio functionality.</p> <p>Notes:</p> <p>Occupant override is not a configurable option. The TASOWiz Zio has a fixed override feature set:</p> <p><b>Occupied</b> with fixed interval configured by: CfgWallModBypassTime 0 ≤ range ≤ 65535 min</p> <p><b>UnOccupied</b> with a Zio user selectable UnOccupied override interval: 1 ≤ range ≤ 99 days</p> <p>Sbus Address = 1 (rotary switch = 1)</p>				
CfgZioWallModTempUnits	AV-1418	AV	0	Home Screen Temperature Sensor display engineering units 0= DegF 1= DegC

STRYKER VAV CONTROLLER

Object Name	Object Type/ID	Net Data Type	Default Val	Description
CfgZioWallModClkFormat	AV-1384	AV	0	12/24 hour clock format 0= 12Hr, 1= 24Hr
CfgZioWallModSystemMode	AV-1385	AV	0	System Mode Type. (Future) 0: No system mode on home screen, 1: Heat only (Off/Heat) 2: Cool only (Off/Cool) 3: Heat and Cool (Off/Cool/Heat), 4: Autochangeover (Off/Auto/Cool/Heat), 5: HeatPump (Off/Auto/Cool/EmrgHeat/Heat) Notes: This is a future field not supported in the current release.
CfgZioWallModFan	AV-1419	AV	0	Fan Control (Future) Notes: This is a future field not supported in the current release.
CfgZioWallModTempOffset	AV-1431	AV	0	Zio on board temperature sensor calibration offset. Offset value is added to the raw sensor value.
CfgZioWallModRhOffset	AV-1432	AV	0	Zio on board humidity sensor calibration offset. Offset value is added to the raw sensor value.
CfgZioWallModUserSched	AV-1386	AV	0	Future option to control Zio user access to change the controller time schedule.
CfgZioWallModPassword	AV-1387	AV	0000	Set end user password to access contractor mode Zio programming. 0000 ≤ range ≤ 9999 Precision: 0

# APPENDIX

## Common Operations

This Appendix describes some of the common control sequences supported by the AscBACnetVAV controller.

### Room Temperature Sensor (RmTemp)

This is the room space temperature sensor. This sensor is the T7770/TR2x or the TR71/75(Zio) Wall Module. When it is configured, it provides the temperature input for the temperature control loop. If it is not configured, it is required that a room temperature sensor value be transmitted from another device via the BACnet network by binding SpaceTempIn. Another option is to Share a Wall Module using 'ModeShareIn, ReheatStgsShareIn, ReheatCmdIn, TempFlowCmdIn, EffectOccln, PeriphStgIn and PeriphCmdIn'. If no valid room temperature value is available to the controller, the temperature control algorithm in the controller is disabled, causing the heating and cooling control outputs to be turned off and the airflow or damper position is set to the minimum setpoint.

The room temperature sensor can be calibrated via the Zio interface or using the custom calibration view available in the Niagara tool.

### Center Setpoint

This is the Setpoint Potentiometer contained in the T7770/ TR2X Wall Module. Zio also allows center setpoint to be modified in the tenant mode under the 'View More' section via a selected Home Screen or View More. The parameter CfgWallModUseWmStPt must be set to 1 to indicate that the controller can use the center setpoint value from the wall module. The values configured for CfgWallModLowSetPt and CfgWallModHighSetPt determine the method used to calculate the effective setpoint: (Offset) and (AbsoluteMiddle).

These values limit the range of the center setpoint. Absolute versus relative center setpoint is determined by the model of T7X/TR2X selected and the configuration of the UI type:

1. TR2x SetPt Absolute (UI\_TR2xSetPtAbs)
2. TR2x SetPt Relative (UI\_TR2xSetPtRel)

Offset: When the Wall Module setpoint limits are between -10° to +10°F, the center setpoint value is added to the configured occupied setpoints for the heat and the cool.

Absolute: When the Center Point value limit is greater than 10 °F then the setpoint knob becomes the center of the Zero Energy Band (ZEB) between the cooling and

heating occupied setpoints. The size of the ZEB is calculate by taking the difference between the heating and cooling occupied setpoints;

Effective setpoint (in cooling mode) = Center setpoint + (CoolOccSpt - HeatOccSpt) / 2.

Effective setpoint (in reheat mode) = Center Setpoint - (CoolOccSpt - HeatOccSpt) / 2

The Wall Module center setpoint is active only when the effective occupancy is Occupied or Bypass.

### Bypass Mode

During Unoccupied periods, the facility occupant can request that Occupied temperature control setpoints be observed by depressing the Bypass push button on the wall module. When activated, the controller remains in Bypass mode until:

1. Bypass Duration Setting has timed out (BypassTime),or
2. User again presses the Wall Module push button to switch off Bypassmode, or
3. Occupancy schedule switches the mode to Occupied.

The LED on the Wall Module indicates the current bypass mode status.

### Bypass Time

BypassTime is the time between the pressing of the override button at the wall module (or initiating OC\_BYPASS via ManOccln) and the return to the original occupancy state. When the bypass state has been activated, the bypass timer is set to BypassTime (defaultof180minutes).

### Override Type (conventional wall modules)

Override Type specifies the behavior of the override button on the wall module. There are three possible states that have the following meanings:

NONE-Disables the override button.

NORMAL-Causes the override button to set the Override state to OC\_BYPASS for BypassTime (default180minutes), when the override button has been pressed for approximately 1 to 4 seconds, or to set the override state to UNOCC when the button has been pressed for approximately 4 to 7 seconds. When the button is pressed longer than approximately 7 seconds, then the override state is set to OC\_NUL (no manual override is active).

BYPASS\_ONLY causes the override button to set the override state to OC\_BYPASS for BypassTime (default 180 minutes), on the first press (1 to 7 seconds). On the next press, the override state is set to OC\_NUL(no manual over ride is active).

## Zio Override

Occupant override is not a configurable option. The Zio has a fixed override feature set:

Occupied with fixed interval configured by:  
CfgWallModBypassTime

0 = range = 65535 min

UnOccupied with a Zio user selectable UnOccupied override interval:

1 = interval= 99 days

## Override Priority

The controller uses a Last-in-Wins scheme to determine effective override state if override is done both from the wall module as well as from the network. The last command received from ManOccIn determines the effective override state.

## Occupancy sensor

The digital input for an occupancy sensor provides the controller with a means to enter an energy-saving Standby mode whenever there are no people in the room. The control behavior in response to occupancy detection can be configured using CfgOccSensorOp to one of the following three options:

UnoccupiedCleaningCrew: When scheduled to be unoccupied and the occupancy sensor is active, controller switches to standby for the comfort of the cleaning crew.

ConferenceRoom: When scheduled to be unoccupied controller stays unoccupied independent of the occupancy sensor activity. During scheduled occupancy, occupancy sensor changes mode between standby and occupied.

UnoccupiedTenant: When scheduled to be unoccupied and the occupancy sensor is active, controller switches to occupied mode for the comfort of the tenant.

## Window Sensor

The digital input for a window contact provides the algorithm with a means to disable its temperature control activities if someone has opened a window or door in the room. When a window is detected to be Open, the box damper is commanded to a configured percentage of maximum CFM (m3h) airflow via CfgWindowOpen. Normal temperature control resumes when the window closes.

## Continuous Unoccupied Mode (conventional wall modules)

This mode is entered when a wall module is configured with a bypass button that was pressed for four to seven seconds, causing the wall module LED to blink. This mode can also be entered via a network command (ManOccIn set to Unoccupied). If the controller is in this mode, it reverts to the Unoccupied Setpoints and control. The controller remains in this mode indefinitely or until the bypass button is pressed to exit the mode or a network command is sent to clear the mode.

## Share Wall Module

If one or more terminal units serve a common area, and it is specified (or desired) to use a single temperature sensor for these boxes, the Share Wall Module option can be configured. The operation of the satellite controllers follows the temperature control and modes of the controller with the temperature sensor module. For example, this includes Temperature Setpoints and Occupied/Unoccupied/Standby/ Bypass modes. This can also be used if there is a need to reprogram multiple satellite controllers based on flexible floor plans. Each controller is fitted with a wall module and the units configured as a ShareWallModule with a valid (ModeShareIn, ReheatStgsShareIn, ReheatCmdIn, TempFlowCmdIn, EffectOccIn, PeriphStgIn and PeriphCmdIn) network connection respond as satellites of the master controller providing (ModeShareOut, ReheatCmdOut, PeriphCmdOut, TempFlowCmdOut, ReheatStgsOut, PeriphHtgStgsOut and EffectOccOut) data.

## Night Purge

If a terminal unit is put into the Night Purge mode, the controller performs the following functions (It):

- Disables the temperature control loop.
- Overrides the flow control loop.
- Controls a damper to a configured percentage of maximum CFM (m3h) airflow (PurgeDmprPos).
- Enables terminal fan.

## Morning Warm-Up

A Morning Warm-Up cycle commands the controller to open its VAV box to a preselected position or reverse acting temperature control to allow the conditioned space to warm up. On boxes with reheat, the reheat can be configured to be either enabled or disabled during morning warmup. See CfgMorningWarmupType



## Smoke Control

The controller supports three smoke-related modes, Pressurize, Depressurize and Purge. When the controller is placed in one of these three modes via [EmergCmdIn (AV-1182)], the box damper is commanded to a fixed position specified in a separate Setpoint for each mode, and the temperature control function is disabled.

## Demand Limit Control

When a high-electrical-demand signal is received via the BACnet network, the controller applies a setpoint shift to the current PID error value (DlcShedIn). This has the effect of bumping the temperature control point to save energy. This offset bumps the cooling control point upward, and bumps the heating control point downward. When the demand limit signal is deactivated, the effective temperature control setpoint returns to the normal value with a 30 minute ramp.

## Start-Up and actuator synchronization

Upon initial start-up or on a restart after power failure, the controller can be configured to drive its actuators open or closed after a configurable startup delay. This allows different controllers to go through different time delays to assure smooth air handling unit start-up, minimizing air distribution problems.

## CO<sub>2</sub> Ventilation

When a CO<sub>2</sub> sensor input is available, the minimum airflow setpoint can be reset automatically by the controller based on configurable CO<sub>2</sub> setpoint limits. A configurable fraction of the maximum flow setpoint is automatically added to the minimum airflow setpoint based on the sensed CO<sub>2</sub> value thereby improving indoor ventilation and air quality.

## Automatic Heat-Cool changeover based on Supply Temperature

When a supply temperature input is configured and a valid value is available, the controller can automatically switch between heat mode and cool mode based on the supply temperature. When the supply temperature is greater than 75 DegF, the control switches to heat mode. If the supply temperature is less than 70 DegF, then the control can automatically switch between cool mode and reheat mode based on the space temperature value as per the following rule:

If the controller is in cool mode and if the space temperature is less than the effective heat setpoint and is less than (effective cool setpoint - 1.0) then the controller switches to reheat mode. While in reheat mode if space temperature is greater than the effective cooling setpoint and greater than the (effective Heat setpoint + 1.0) then the controller switches to cool mode.

## Airflow Control Sequences of Operation

The primary function of the temperature-control application is to regulate the quantity of supply air delivered to the space to control the space temperature. The algorithm assumes there is cold air in the duct; therefore, as the box damper is opened wider, the space becomes cooler. The damper is commanded between configurable minimum and maximum positions for pressure dependent control. For pressure independent control, the damper is commanded between configurable minimum and maximum flow setpoints. When a flow sensor input is not available, control automatically switches to pressure dependent control. Damper/airflow control is also coordinated with CO<sub>2</sub> sensor value when available to maintain the required indoor ventilation.

## Flow Tracking

The controller can be configured for flow tracking. This feature is used to balance the flow between several input vav boxes and one exhaust vav box in a room. Typically, the exhaust box controller is configured as the flow tracking controller. Temperature control is disabled in flow tracking mode and the controller commands the damper to achieve a flow setpoint that is calculated by adding a configured flow offset value to the supply flow of all the input vav boxes. See FlowTrackIn (AV-1189) and CfgFlowType.

Flow Tracking Application Notes:

1. Flow tracking is intended for noncritical, slow responding commercial building zone pressurization control sequences. This means that average pressurization can be maintained if disturbances are slow acting, but fast disturbances may result in temporary short term imbalances. Do not apply the VAV Flow Tracking option in life safety or industrial environments such as clean rooms, fume hoods, or bio hazard control.
2. Flow tracking requires high resolution airflow damper actuators. Floating actuators are recommend.





*BACnet<sup>®</sup> is a registered trademark of American Society of Heating Refrigeration and Air Conditioning Engineers (ASHRAE).*

*WEBStation is a registered trademark of Honeywell.*

**Automation and Control Solutions**

Honeywell International Inc.  
1985 Douglas Drive North  
Golden Valley, MN 55422  
[customer.honeywell.com](http://customer.honeywell.com)

® U.S. Registered Trademark  
© 2016 Honeywell International Inc.  
31-00105-01 M.S. 05-16  
Printed in United States

**Honeywell**