



Control Air 5600

Multi-Protocol Heat Pump Controller



BOSCH

Hardware User Manual

Table of Contents

1 Key to Symbols and Safety Instructions	4	6 Water to Water Systems	19
1.1 Key to Symbols	4	6.1 DDC Options	19
1.2 Safety Warnings	4	6.1.1 Pump control	19
2 Control Air 5600 Specifications	5	6.2 I/O Port Assignments And Overview	19
3 Control Air 5600 Overview	5	6.3 Sequence Of Operation	21
3.1 Key Features/Benefits	5	6.3.1 Unit Start Up	21
3.2 Components Overview	6	6.3.2 Setpoint Management	21
4 Control Air 5600 Features	7	6.3.3 Heating/Cooling Operation	21
4.1 Network	7	6.3.4 Unit Shutdown/Lockout	22
4.2 Rotary Dials	7	7 ZS Combination Sensors	23
4.3 Lon Port	7	7.1 Available Models	24
4.4 Rnet port	7	7.2 Specifications	24
4.5 Part Number	7	7.3 Features	25
4.6 Inputs	7	7.4 Addressing Sensors	27
4.7 Battery	7	7.5 Multiple Sensors	27
4.8 Local Access	7	7.6 Formatting Sensors	27
4.9 Power	7	7.7 ZS Push/Manager Sensors	28
4.10 DIP Switch	7	7.7.1 Navigating the Push/Manager Sensor's Screens	28
4.11 Outputs	7	7.7.2 ZS Push Sensor Display	28
4.12 IN-1 Jumper	7	7.7.3 Make the Zone Warmer or Cooler Using a ZS Push/Manager	29
4.13 IN-2 Jumper	7	7.7.4 To Override the Schedule Using a ZS Push/Manager	29
4.14 Communication Jumper	7	7.7.5 To Lock the Sensor Buttons of a ZS Push/Manager	30
5 Water to Air Systems	9	7.7.6 To Edit Displayed Values Using a ZS Push/Manager	30
5.1 DDC Options	9	7.8 Rnet Tags	30
5.1.1 Air Economizer (Free Cooling)	9	7.8 Wiring and Mounting a ZS Sensor	33
5.1.2 Auxiliary Electric Heat	9	8 Control Air M/M+	34
5.1.3 Boilerless Control	9	8.1 The Control Air M/M+ Interfaces	34
5.1.4 Fan Proving	9	8.2 The Control Air M/M+ Module	34
5.1.5 Flow Proving (DPS)	9	8.3 Virtual Control Air M/M+ (Equipment Touch (OEM) APP)	34
5.1.6 Loop Water Valve Control	9	8.4 Control Air M/M+ Specifications	35
5.1.7 Hot Gas Reheat	9	8.5 Wiring	36
5.1.8 Input Expansion Module (IEM)	9	8.5.1 Recommended Wiring Scheme	36
5.1.9 Outside Air Damper	9	8.5.2 Rnet Wiring Specifications	36
5.1.10 Water-Side Economizer	9	8.6 Connection	36
5.2 I/O Port Assignments And Overview	10	8.6.1 Communicate Using a Tablet Through Virtual Control Air M and M+	36
5.3 Sequence Of Operation	16	8.6.2 To Wire and Mount the Control Air M/M+	36
5.3.1 Unit Start Up	16	8.6.3 Additional Information on Connecting Control Air M/M+ to a Controller	37
5.3.2 Temperature Source Selection	16	9 Troubleshooting	39
5.3.3 Setpoint Management	16	9.1 Control Air 5600	39
5.3.4 Heating/Cooling Operation	17	9.2 ZS Sensors	39
5.3.5 Unit Shutdown/Lockout	17	9.3 Communication LED's	40
5.3.6 Options	17		

Table of Contents Continued

10 Physical Dimensions and Specifications	41
10.1 Control Air 5600 Controller Dimensions	41
10.2 Input Expansion Module (IEM) Features	41
10.3 Control Air M/M+ Dimensions	42
10.4 ZS Series Zone Sensor R1 Dimensions	43
10.5 Wiring Termination Specs	43

11 Electrical Schematics	44
11.1 Water to Air	44
11.2 Water to Water	45

12 Terminology	46
-----------------------	-----------

13 Common Abbreviations	46
--------------------------------	-----------

14 Thermostat Signals	47
------------------------------	-----------

1 Key to Symbols and Safety Instructions

1.1 Key to Symbols

Warnings



Warnings in this document are identified by a warning triangle printed against a grey background.

Keywords at the start of a warning indicate the type and seriousness of the ensuing risk if measures to prevent the risk are not taken.

The following keywords are defined and can be used in this document:

- ▶ **DANGER** indicates a hazardous situation which, if not avoided, will result in death or serious injury.
- ▶ **WARNING** indicates a hazardous situation which, if not avoided, could result in death or serious injury.
- ▶ **CAUTION** indicates a hazardous situation which, if not avoided, could result in minor to moderate injury.
- ▶ **NOTICE** is used to address practices not related to personal injury.

Important information



This symbol indicates important information where there is no risk to people or property.

1.2 Safety Warnings



WARNING: FIRE, INJURY OR DEATH HAZARD

- ▶ Installation and servicing of this equipment can be hazardous due to system pressure and electrical components. Only trained and qualified personnel should install, repair, or service the equipment.



WARNING: ELECTRIC SHOCK HAZARD

- ▶ Before performing service or maintenance operations on the system, turn off main power to the unit. Electrical shock could cause personal injury or death.



CAUTION: FIRE, INJURY HAZARD

- ▶ When working on equipment, always observe precautions described in the literature, tags, and labels attached to the unit. Follow all safety codes. Wear safety glasses and work gloves. Use a quenching cloth for brazing, and place a fire extinguisher close to the work area.



WARNING: FIRE, ELECTRICAL SHOCK HAZARD

- ▶ To Reduce the risk of Fire or Electric Shock, Do not interconnect the outputs of different class 2 circuits.



WARNING:

- ▶ This product can expose you to chemicals including Lead and Lead components, which are known to the State of California to cause cancer and birth defects or other reproductive harm. For more information go to www.P65Warnings.ca.gov.

2 Control Air 5600 Specifications

Power:

24VAC \pm 10%, 50-60Hz, 1.4 VA of standby power consumption (Single Class II 70VA or 100VA option available).

Physical:

Rugged plastic housing protects circuitry.

Environmental Operating Range:

A range of 0°F to 130°F (-17.8 °C to 54.4°C); 10% to 90% relative humidity, non-condensing.

Digital Outputs:

Five(5) binary outputs - Form A relay contacts rated at 10A resistive @ 24VAC; configured as dry contact, normally open.

Universal Inputs:

Six (6) universal inputs. All six inputs are configurable for pulse, 10kohm @ 77°F (25°C) thermistor, or dry contact. In addition, inputs 1 and 2 are configurable for 5Vdc.

Standard Communication:

3-pin port configurable for ARC156 (BACnet-over- ARC156) or EIA-485 communications (BACnet MS/ TP, Modbus RTU, Lon, or N2).

Ports

- ▶ **Rnet Port:**
4-pin port for interface with remote mounted CAM (data only, no power) or ZS sensors
- ▶ **Local Access Ports:**
For local communication with a laptop computer running WebCTRL, or for communication with the CAM interface (tablet app only)

BACnet Support:

Advance Application Controller (B_AAC), as defined in BACnet 135-2001 Annex L Communications Ports.

Status Indication:

Visual (LED) status of network communication, run status, errors, power, and all digital outputs.

Battery:

Lithium 3V coin cell battery, CR2032, provides a minimum of 10,000 hours of data retention (based on installation in condition space) during power outages.

Protection:

Surge and transient protection circuitry for power and communications.

Listed By:

FCC Part 15-Subpart B- Class A. Pending listings at the time of publishing this document: UL916 (PAZX), cUL C22.2No.205-M1983 (PAZX7), CE (1997).

Weight:

0.6 Lbs. (0.27 Kg).

Overall Dimensions:

(W x H x D) 5-1/16" (129mm) x 5-11/16" (144mm) x 1-1/2" (38mm) (recommended panel depth).

Mounting Hole Dimensions:

Two mounting holes located center line of controller with 5-9/16" (141mm) vertical spacing.

3 Control Air 5600 Overview

The Control Air 5600 Multi-Protocol Heat Pump controller is used in most configure-to-order applications requiring integration of Direct Digital Control (DDC) systems. The controller is BACnet native but is flexible enough to integrate into existing Building Automation Systems (BAS) via a choice of the most widely used protocols including: BACnet MS/TP, N2, Modbus, and LON (requires additional hardware). The Control Air 5600 may be run either in standalone operation mode, or with the DDC network by integrating with a BAS.

The Control Air 5600 is packaged with a highly sophisticated yet easily configurable software that suits the different heat pump applications. User parameters and options relating to the physical build of the corresponding heat pump unit (e.g. number of compressors, reversing valve, etc) are usually programmed at the factory to facilitate a seamless integration in the field. However, commissioning of the controller in the field is required to ensure the setup exactly matches the requirements of the job site. User settings of the factory standard software, such as the time and test and balance set points, are usually set up during the installation and commissioning process.

When properly connected to a Bosch Water Source Heat Pump (WSHP), the Control Air 5600 controller works in tandem with the onboard Unit Protection Module (UPM) to protect the unit compressor from faults such as high/low pressure, high condensate, freeze evaporator/condenser coils, and brownouts. The controller monitors the alarm contacts of the UPM board, then decodes and broadcasts any fault conditions that may arise over a network if one is available.

3.1 Key Features/Benefits

1. Provides multi-protocol communications for seamless integration with systems running industry standard protocols such as:
 - a. BACnet over ARCnet
 - b. Johnson Controls N2
 - c. Modbus
 - d. Lon Works (additional hardware required for Lon)
2. Ruggedly built for quality and reliability
3. Stand-alone operation or networked DDC operation capable
4. Removable wiring connectors for ease of field service
5. Allows application parameters to be saved and recovered following power loss

3.2 Components Overview

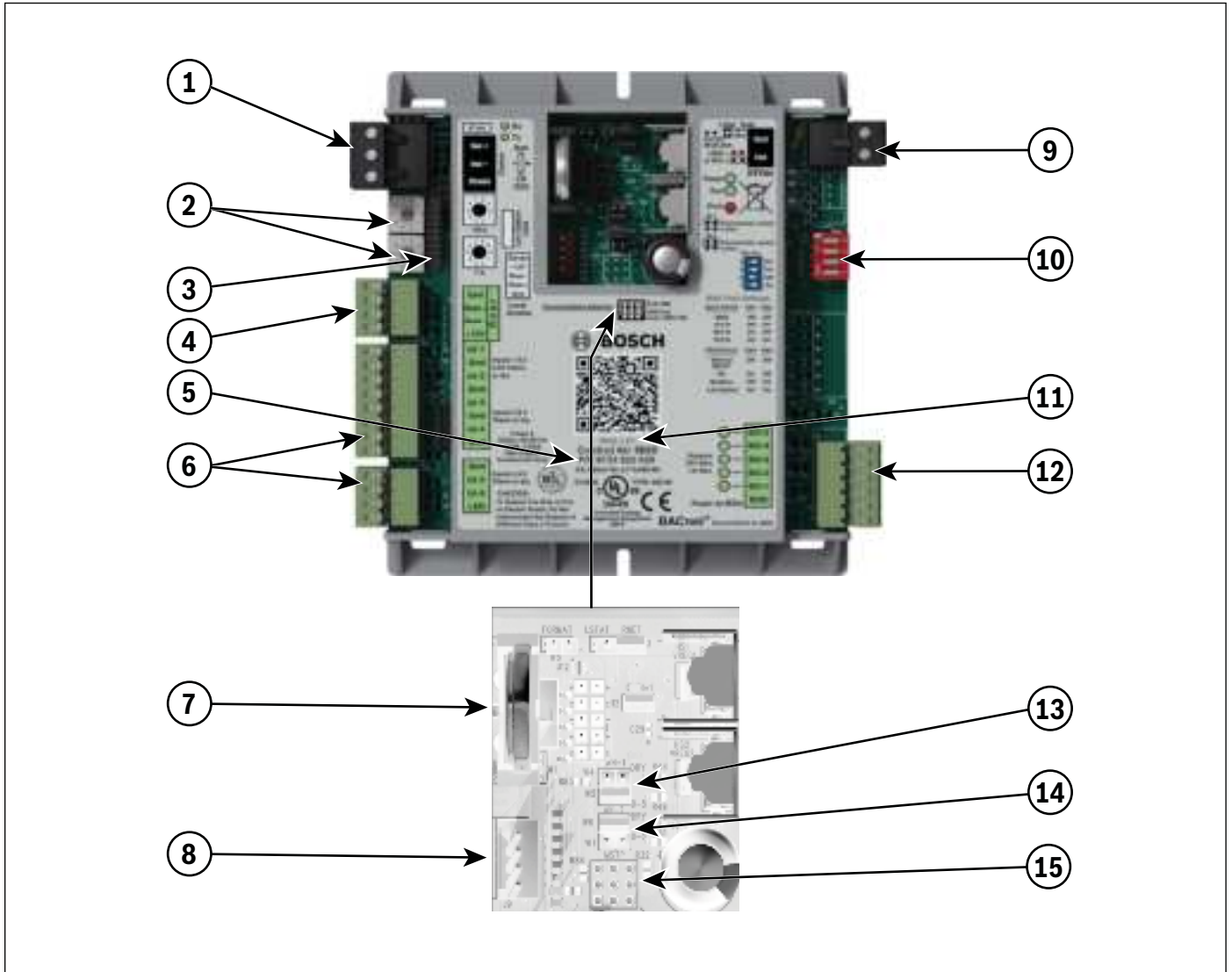

Figure 1

Components List:

1. Network
2. Rotary Dials
3. Lon Port
4. Rnet Port
5. Part Number
6. Inputs
7. Battery
8. Local Access
9. Power
10. DIP Switch
11. Software Version
12. Outputs
13. IN-1 - Jumper
14. IN-2 - Jumper
15. Communications Jumper

4 Control Air 5600 Features

4.1 Network

This block represents the communications port on the Control Air 5600. This port can be configured to communicate in two ways (RS-485 or BACnet over ARC156) using the Communications Jumper. The communications wiring should be landed at the Net+, Net-, and Shield terminals, ensuring the same polarity is maintained throughout the network segment. The "BAS Port Settings" DIP switch is used to set the baud rate for the network, using the same baud rate for all controllers on the network. The LEDs (Rx and Tx) flash repeatedly when the controller is communicating with the network. This port is also used for data when connecting a Control Air M+ to the controller.

4.2 Rotary Dials

The rotary dials are used to address the Control Air 5600 so it can be uniquely identified over a network. The top dial represents the Tens digit while the bottom one represents the Ones digit. Before setting or changing the address make sure the Control Air 5600 is powered off; the controller only reads the address when the module is turned on.

4.3 Lon Port

For network integration applications involving the LonWorks network platform, the LON card will be required to enable communication over this protocol. The card is ordered separately and connects to the Lon port. Ensure that the communications jumper is in the top position (EIA-485) and the BAS port settings are configured using the DIP switch bank (see DIP Switch)

4.4 Rnet port

The Rnet port is a four-connector block reserved mainly for wiring the ZS combo sensors to the Control Air 5600. It consists of 2 points for power (12VDC and Gnd) and 2 points for communication (Rnet+ and Rnet-). This port is also used for data when connecting a Control Air M to the controller (Rnet+ and Rnet- only).

4.5 Part Number

The Control Air 5600 part number represents both the hardware and software components of the Control Air 5600, and therefore changes if the controller is ordered with a special software other than the standard (WAZ.1.01) version.

4.6 Inputs

There are 6 universal inputs on the Control Air 5600. All inputs are capable of accepting thermistor (analog), pulse or dry contact (binary) signals, but the first 2 inputs (IN-1 and IN-2) are also capable of reading 0-5VDC signals; use the corresponding jumpers to select between Therm/dry and 0-5V for these inputs. Refer to the "Ports Assignment and Overview" page for further details on configuring these inputs.

4.7 Battery

The 10-year Lithium CR2032 3V battery retains data (e.g. control programs, modified parameters, schedules, etc) for a maximum of 10,000 hours during power outages. If the Control Air 5600 experiences RAM loss (e.g. due to low voltage on the controller or high voltage on the network), it may be reset by recycling the battery power. This operation should be performed with the Control Air 5600 powered off (no 24Vac power), and resolves most of all "bad controller" issues. All **previously saved** parameters are retained upon power up.

4.8 Local Access

The local access port is available for system startup, servicing and troubleshooting using a CAM interface (tablet app).

4.9 Power

Input power for the Control Air 5600. 24Vac +/-10%, 50-60Hz; 20VA power consumption, Single Class 2 source only, 100VA or less.

4.10 DIP Switch

The BAS Port Settings DIP switch bank is used to set the appropriate network configuration when the Control Air 5600 is integrated into a Building Automation System (BAS). (See table # 2)

4.11 Outputs

The Control Air 5600 has five (5) binary outputs that can each be connected to a maximum of 24Vac/26Vdc. Each output is a dry contact (Form A) rated at 1A, 24V max. Refer to the "Ports Assignment and Overview" page for further details on configuring these outputs.

4.12 IN-1 Jumper

This two-position jumper is used to set the input type selection for IN-1 as follows:

- ▶ Top position is labeled W4 and configures IN-1 for dry/therm signals.
- ▶ Bottom position is labeled W5 and configures IN-1 for 0-5V signals.

The jumper is default to the bottom position (W5) for 0-5V from factory.

4.13 IN-2 Jumper

This two-position jumper is used to set the input type selection for IN-2 as follows:

- ▶ Top position is labeled W6 and configures IN-2 for dry/therm signals
- ▶ Bottom position is labeled W7 and configures IN-2 for 0-5V signals.

The jumper is default to the top position (W6) for Dry/Therm from factory.

4.14 Communication Jumper

This two-position jumper is used to configure the network communication mode for the Control Air 5600 as follows:

- ▶ Top position is labeled EIA-485 and configures the Control Air 5600 for RS-485 communications for BACnet MS/TP, N2, ModBus, or Lon.
- ▶ Bottom position is labeled BACnet over ARC156 and configures the Control Air 5600 for BACnet over ARC156 at 156kbps. This selection is a unique implementation of the industry standard ARCNET protocol and the jumper should only be set to this position if employing that protocol.

Input	Signal Type Supported	Description
IN-1 AND IN-2	0-5Vdc	Input impedance of the Control Air 5600 is approx. 30-kOhm
ALL	Thermistor	Precon type2 (10-kOhm @ 77° F/ 25°C)
ALL	Dry Contact	3.3Vdc wetting voltage detects contact position
ALL	Pulse	Pulse counting up to 10 pulses per second.

Table 1

Baud Rate Setting			Protocol		
	SW1	SW2		SW3	SW4
9.6KBPS	Off	Off	BACnet®MS/TP	Off	Off
19.2KBPS	Off	On	N2	On	Off
38.4KBPS	On	Off	Modbus	Off	On
76.8KBPS	On	On	Option Card (LON)	On	On

Table 2



Table 2 details the different communications settings available (this information is also on the Control Air 5600 label)

5 Water to Air Systems

5.1 DDC Options

5.1.1 Air Economizer (Free Cooling)

This option utilizes an outdoor air temperature and humidity combo sensor, and a field supplied fresh air damper to provide free cooling. When there's a call for cooling, the OAT/RH sensor connected to the Control Air 5600 will monitor the outside air temperature and humidity levels and determine if the compressor should be used for cooling or if the outdoor air is ideal to condition the space with just the fan. If the air temperature and humidity is within a user-configurable range, the damper solenoid will be energized to open by the Control Air 5600, the compressor will be indexed off, and the fan is used to cool the space.

This option is only available in the cooling mode.

5.1.2 Auxiliary Electric Heat

Used to provide a single stage of electric heat by using a factory-installed electric heater option, or field-installed electric heater accessory. It may be used as a supplementary source of heating for units with mechanical heating/cooling capabilities where additional heating capacity is needed to meet/maintain space setpoint; or as the sole source of heat for straight cool units (mechanical cooling only). The configured controller output is energized to enable the heater based on unit configuration and parameter setup.

5.1.3 Boilerless Control

An option that allows a water source heat pump to be operated in heating safely when installed in a system that has no means of heating the water loop. A factory installed Entering Water Temperature (EWT) sensor (thermistor) is connected to the Control Air 5600 controller and used with this option. During a call for heating, if the EWT sensor detects a drop in water temperature below a pre-set limit (adjustable in the software), the Control Air 5600 will disengage the compressor output(s) and provide a 24VAC signal to divert unit operation from compressor heating to an alternate heat source (generally field-installed electric heat). The option is also used to proactively prevent coils from freezing.

5.1.4 Fan Proving

This option uses a factory-installed current sensor to prove fan operation prior to unit operation. The status output of the current sensor is used to establish fan operation for the unit when a proven fan call is established. If configured the Control Air 5600 disables unit compressor operation when the current in the monitored conductor drops below the rated threshold, indicating the fan is nonoperational. The current sensor output may be wired directly to the Control Air 5600, or to an Input Expansion Module (IEM) connected to the Control Air 5600 when multiple options requiring switched inputs are involved. Please consult the applications department when including this option as an engineering add-on.

5.1.5 Flow Proving (DPS)

This option employs the use of a Differential Pressure Switch (DPS) to prove water flow across a unit's water-to-refrigerant heat exchanger. If configured the software enables unit compressor operation when a pressure drop of 1.5 psi or more is detected across the water to refrigerant heat exchanger, indicating adequate water flow. This option prevents nuisance cut-outs on high head pressure or freeze protection when there are interruptions in water flow.

5.1.6 Loop Water Valve Control

This option uses a factory-installed condenser water valve to control water flow through the condenser coil. The normally closed valve includes an auxiliary end switch that is wired to the controller to determine the status of the valve. When the Control Air 5600 is configured for this option, compressor operation is disabled until valve-open status from the valve end switch is verified.

5.1.7 Hot Gas Reheat

Hot gas reheat helps actively controls humidity by reheating cooled and dehumidified air back to a neutral temperature using waste heat from the compressor. Doing this allows the unit to continue to operate and remove moisture from the space even after the sensible cooling set point has been satisfied. Hot gas reheat is well suited for conditioning outside ventilation air and for maintaining ideal humidity levels in schools, commercial buildings and even homes. A binary output on the Control Air 5600 controller is used to provide the signal for activating the reheat valve when the necessary conditions are met. Relative humidity readings may be acquired from a wall-mounted ZS combo sensor, a third-party hard wired 0-5V humidity sensor, or from RH values pushed to the Control Air 5600 over a network.

5.1.8 Input Expansion Module (IEM)

The IEM is used when multiple options that require a binary input are desired for a single application with DDC. The IEM is connected in input #5 (IN-5) of the Control Air 5600 controller and is software configured to enable a trio of preset combinations that include: Fan Status, Valve Status, Damper Status, Pump Status, Filter Status, Secondary Drain Pan Status, Differential Pressure Switch Status, and Smoke/Fire Detector Status. (see page #32 Figure# 14 for more details on the IEM).

5.1.9 Outside Air Damper

Allows the capability for pre-filtered outside air to enter the unit while in operation via a motorized, field supplied damper, based on unit occupancy, fan operation, or CO2 levels in the monitored space. A binary output on the Control Air 5600 controller is used to provide the signal for activating the damper solenoid when the necessary conditions are met. CO2 readings may be acquired from a wall-mounted ZS combo sensor, a third-party hard wired 0-5V CO2 sensor, or from CO2 values pushed to the controller over a network. A damper end switch connected to the controller may be used to verify damper status and disable compressor operation when the damper fails.

5.1.10 Water-Side Economizer

An optional package consisting of a water-to-air heat exchanger (economizer coil), a thermistor (EWT sensor), and a 3-way diverting valve. When there is a call for cooling, the EWT sensor connected to the Control Air 5600 will monitor the entering water temperature to the unit and determine if the compressor should be used for cooling or if the water temperature is low enough to cool the entering air with the economizer coil. If the entering water temperature is below a selected user-adjustable set point, the diverting valve will be indexed by the Control Air 5600 to divert the entering water through the economizer coil to cool the air stream. This DDC option can only be used for cooling operations.

5.2 I/O Port Assignments And Overview

Universal Inputs				
Port	Inputs Accepted	Signal Type	Jumper Position	Overview
IN-1	Digital Input Enable	Dry	Top(W4)	This input is selected when a dry contact (e.g. room occupancy sensor) is required to enable the unit, and Digital Input has been selected for Occupancy Command. Unit is placed in occupied mode upon a contact closure at the input, and placed in unoccupied mode 10 minutes after the contacts reopen.
	Humidity Sensor	0-5VDC	Bottom (W5)	This input is used if RH readings are not desired from a ZS Combo sensor or over a network. An example would be a duct mounted humidity sensor or third party humidity sensor with 0- 5VDC output.
	CO2 Sensor	0-5VDC	Bottom (W5)	This input is used if CO2 readings are not desired from a ZS Combo sensor or over a network. An example would be a third party CO2 sensor with 0-5VDC output.
	Static Pressure Sensor	0-5VDC	Bottom (W5)	This input is used for applications requiring static pressure readings.
IN-2	Zone Remote Sensor	Therm	Top (W6)	This input is used if zone temperature readings for controlling the unit are not desired from a ZS Combo sensor or over a network. An example would be a third party wall or duct mounted sensor. Temperature sensor must be a Type II 10kohm @ 77°F(25°C) sensor.
	Outdoor Air Temperature Sensor	Therm	Top (W6)	This input is selected if outside air temperature readings are required.
	Entering Water Temperature Sensor	Therm	Top (W6)	This input should be selected for applications where the entering water temperature needs to be monitored, or used to control options such as Economizer or Boilerless Electric Heat.
	Mixed Air Temperature Sensor	Therm	Top (W6)	This input is selected if mixed air temperature readings are required
	Return Air Temperature Sensor	Therm	Top (W6)	This input is used if zone temperature readings for controlling the unit are desired from a temperature probe placed in the return air duct. Temperature sensor must be a Type II 10kohm @ 77°F(25°C) type sensor.
	Digital Input Enable	Dry	Top (W6)	This input is selected when a dry contact (e.g. room occupancy sensor) is required to enable the unit, and Digital Input has been selected for Occupancy Command. Unit is placed in occupied mode upon a contact closure at the input, and placed in unoccupied mode 10 minutes after the contacts reopen
	Humidity Sensor	0-5VDC	Bottom (W7)	This input is used if RH readings are not desired from a ZS Combo sensor or over a network. An example would be a duct mounted humidity sensor or third party humidity sensor with 0- 5VDC output.

Table 3

Universal Inputs				
Port	Inputs Accepted	Signal Type	Jumper Position	Overview
IN-3*	Leaving Water Temperature Sensor	Therm	n/a	A thermistor is wired to this input from factory to monitor leaving water temperature at the heat exchanger leaving water pipe. If the water temperature rises above 135°F or drops below 40°F for more than 5 minutes while the unit is running, compressor operation is halted and an alarm is generated. These temperature trip values are user adjustable.
IN-4*	UPM Input	Pulse	n/a	The Unit Protection Module (UPM) is standard on all FHP heat pumps. The alarm contacts of the UPM board are wired to the controller at this input from factory to transmit error pulse codes to the Control Air 5600. These alarm codes are then made available to view via a CAM/M+ interface, ZS Pro Sensor, or over a network if one is available. Faults include: High Pressure, Low Pressure, High Condensate, Freeze Stat, and Brown out conditions.
IN-5	Dirty Filter Switch (DFS)	Dry	n/a	Selecting this option for this input provides an alternate means of alerting the end user of a dirty filter condition by way of a contact closure instead of fan runtime hours. An alarm is generated when Control Air 5600 senses a contact closure at the input.
	Entering Water Temperature Sensor (Economizer Cooling & Boilerless Electric Heat)	Therm	n/a	This input should be the default location for an EWT sensor when the Water-Side Economizer or Boilerless Electric Heat option is selected. The temperature readings from this input are used in determining when the Economizer or Electrical Heat action is enabled and MUST be selected for the option to function properly. Default economizer EWT trip value is 55°F (user adjustable). Default Boilerless EH EWT trip value is 40° F (user adjustable).
	Differential Pressure Switch (DPS)	Dry	n/a	A Differential Pressure Switch may be connected to this input to prove water flow across a unit's water- to-refrigerant heat exchanger. Heat pump operation is disabled until the DPS is closed.
	Secondary Drain Pan (SDP)	Dry	n/a	This option allows a secondary condensate pan installed on the heat pump to be connected to this input to monitor condensate levels when the primary drain pan fails. When a high condensate condition for the secondary drain pan is detected an open contact status is reported at the input, and the compressors are locked out until the condition is reversed. An alarm is generated when the Control Air 5600 senses an open contact at the input.
	Fan Status Switch (FSS)	Dry	n/a	The status output from a factory installed current sensor used to monitor fan operation may be connected to this input to provide fan status during unit operation. The unit is allowed to run only when the sensor contacts are verified as closed at the input after the fan has been indexed to run. If there's no contact closure after the fan has been commanded on, the unit is not allowed to run, and an alarm is generated after 45 seconds. If the fan fails during normal unit operation the compressors are shutdown after 20 seconds and an alarm is generated.

Table 4



*Non-configurable, factory assigned I/O parameter. All I/Os must be selected/configured in the software.

Universal Inputs				
Port	Inputs Accepted	Signal Type	Jumper Position	Overview
IN-5	Valve End Switch (VES)	Dry	n/a	For units with a loop valve option, the valve end switch may be connected to this input to monitor/verify valve status during unit operation. The factory-installed zone valve is normally-closed and is indexed to open by the Control Air 5600 when there's a call for heating or cooling. If a contact closure is not detected at the input after the valve is commanded on, unit operation is disabled and an alarm is generated after a minute and a half has elapsed; this provides adequate time for the slow acting valve to fully open.
	Damper End Switch (DES)	Dry	n/a	A damper end switch may be connected at this input for units with the outside air damper option. If connected, the unit is not allowed to run until a contact closure is detected at the input after the damper has been indexed to open. Damper operation may be based on occupancy, fan operation, or zone CO2 levels (default trip value is 1000ppm).
	Smoke Detector Switch (SDS)	Dry	n/a	The normally-open contacts of a field-installed smoke/fire alarm detector or emergency shutdown switch may be wired to this input to shut the heat pump unit down during an emergency. Unit operation is ceased 5 seconds after a contact closure is detected at the input.
	Pump Status Switch (PSS)	Dry	n/a	For units with a loop pump option, the status output from a factory installed current sensor used to monitor pump operation may be connected to this input to provide pump status during unit operation. The unit is allowed to run only when the sensor contacts are verified as closed at the input after the pump has been indexed to run. If there's no contact closure after the loop pump has been commanded on, the unit is not allowed to run, and an alarm is generated after 15 seconds. If the pump fails during normal unit operation the compressors are shutdown after 20 seconds and an alarm is generated.
	Mixed Air Temperature Sensor	Therm	n/a	Select this configuration parameter if a Mixed Air Temperature sensor is connected in IN-5.

Table 5

Universal Inputs				
Port	Inputs Accepted	Signal Type	Jumper Position	Overview
IN-5				The Input Expansion Module (see figure # 14) is used in this input when multiple options that require a binary input are required (up to 3 inputs). The combinations of these options are limited only to the seven (7) sets of three listed below
	INPUT EXPANSION MODULE (IEM) COMBINATION PORT 1 (A).....PORT 2 (B).....PORT 3 (C)			
	Dirty Filter Switch (DFS)	Fan Status Switch (FSS)	Valve End Switch (VES)	These seven (7) sets of binary input combinations may be used with an IEM connected to this input. The three (3) ports are labeled (A, B, C) and must be connected correspondingly. In situations where not all three inputs are used, the other inputs may be disabled in the software, or the board may be jumpered if the option requires a closed contact to function properly.
	Smoke Detector Switch (SDS)	Fan Status Switch (FSS)	Valve End Switch (VES)	
	Dirty Filter Switch (DFS)	Fan Status Switch (FSS)	Differential Pressure Switch (DPS)	
	Smoke Detector Switch (SDS)	Fan Status Switch (FSS)	Dirty Filter Switch (DFS)	
	Dirty Filter Switch (DFS)	Fan Status Switch (FSS)	Damper End Switch (DES)	
	Smoke Detector Switch (SDS)	Fan Status Switch (FSS)	Secondary Drain Pan (SDP)	
Dirty Filter Switch (DFS)	Fan Status Switch (FSS)	Pump Status Switch (PSS)		
IN-6*	Discharge Air Temperature	Therm	n/a	A factory-installed thermistor mounted on the heat pump unit's blower housing (air handler section) is connected to this input for all orders requiring the factory installed DDC option. It is highly recommended that for applications requiring a more accurate representation of the supply air temperature, a duct mounted temperature probe be used instead to relocate the source of the discharge air temperature just downstream of the supply air duct. If this recommendation is followed the factory-installed thermistor may be disconnected from this input, and replaced with the leads from the duct mounted sensor.

Table 6



*Non-configurable, factory assigned I/O parameter. All I/Os must be selected/configured in the software.

Universal Inputs				
Port	Inputs Accepted	Signal Type	Jumper Position	Overview
BO-1*	Fan	24VAC	G	Binary Output 1 is factory reserved for the fan command (G) and is wired to the unit terminal block in the electrical box. The fan mode may be software configured either for “continuous” mode (fan is energized continuously during occupied and night set back modes), or configured to run in “auto” mode (fan is energized only during a call for heating or cooling). Continuous mode is the factory default.
BO-2*	Reversing Valve	24VAC	O	Binary Output 2 is factory reserved for the reversing valve command (O) and is wired to the valve via the unit terminal block in the electrical box. For heat pump units, the output is energized during a call for cooling, and remains de-energized for heating. For straight cool units (cooling only) where no reversing valve is installed, the output is disabled and not used.
BO3*	Compressor Stage 1	24VAC	Y1	Binary Output 3 is factory reserved for the compressor stage 1 command (Y1) and is connected to the UPM I board's "Y" terminal ("Y1" for dual compressor units using the UPM II board) via the unit terminal block in the electrical box. The Y1 output is off when zone setpoint is satisfied and within the temperature dead band (between heating and cooling setpoints). As the zone temperature rises above the cooling setpoint and demand exceeds 30%, Y1 is enabled and PID methods are employed to ensure the zone temperature is maintained within 1°F of cooling setpoint. As the zone temperature drops below the heating setpoint and demand exceeds 30%, Y1 is enabled and PID methods are employed to ensure the zone temperature is maintained within 1° F of heating setpoint.
BO-4*	Compressor Stage 2	24VAC	Y2	Binary Output 4 is factory defaulted for the compressor stage 2 command (Y2) and is connected to the second stage solenoid (Y2S) for 2-step, single compressors, or to the "Y2" terminal for dual compressor units using the UPM II board, via the unit terminal block in the electrical box. The Y2 output is off when zone setpoint is satisfied and within the temperature dead band (between heating and cooling setpoints). The Y2 output is energized after Y1 has been on for more than 7 minutes, and the heating/cooling demand exceeds 60%. For 1 compressor 1 stage units, Binary Output 4 may be configured for one of the following options: Water-side economizer, Boilerless, or Outside Air Damper (On/Off).
	Economizer Cooling Control	24VAC	E	
	Fresh Air Damper (On/Off)	24VAC	D	
	Boilerless Control	24VAC	W	

Table 7



*Non-configurable, factory assigned I/O parameter. All I/Os must be selected/configured in the software.

Universal Inputs				
Port	Inputs Accepted	Signal Type	Jumper Position	Overview
B0-5*	Hot Gas Re-Heat (On/Off)	24VAC	H	Binary Output 5 may be factory or field configured for one of the following options: Hot Gas Reheat (On/Off), Single Stage Auxiliary Electric Heat, Outside Air Damper (On/Off), Condenser Water Valve, Circulating Water Pump, Economizer, or Boilerless Electric Heat.
	Fresh Air Damper (On/Off)	24VAC	D	
	Heating Stage 1 (Aux Heat)	24VAC	W	
	Boilerless Control (Aux Heat)	24VAC	W	
	Economizer Cooling Control	24VAC	E	
	Condenser Water Valve	24VAC	CV	

Table 8



*Non-configurable, factory assigned I/O parameter. All I/Os must be selected/configured in the software.

5.3 Sequence Of Operation

5.3.1 Unit Start Up

Program will check schedule status for either occupied or unoccupied mode to determined setpoint range. Different run conditions may determine the occupancy mode.

5.3.1.1 External Control Sources

Digital input

A contact closure (in IN-1 or IN-2) is used to enable unit operation. Once enabled, unit will run until set-point is satisfied, or 10 minutes has elapsed since contacts opened.

BAS

A network point is used to command the unit into occupied or unoccupied mode.

Manual on

The heat pump is placed in continuous run mode and will operate until setpoint is satisfied.

Override

For units with ZS wall-mounted sensors or CAM interface, unit operation may be overridden into occupied mode using a push button on the sensor or CAM interface screen. Software may be configured to disallow sensor override from the space, time for override is in increments of 30 minutes, with a max of 3 hours allowed.

5.3.1.2 Internal Control Sources

Local Schedule

The internal scheduler uses the local time and user-defined schedule to determine occupancy.

Default schedule is:

Day of Week	Time	Mode
MON-FRI	8:00AM - 5:00PM	Occupied Mode
SAT	7:00AM - 3:00PM	Occupied Mode
SUN	10:00AM - 1:00PM	Occupied Mode

Table 9



Unit is in unoccupied mode outside the above stated hours.

Default Occupied Schedule Set Points:

- ▶ 74°F Cooling setpoint (Adjustable)
- ▶ 70°F Heating setpoint (Adjustable)

Default Unoccupied Schedule Set Points:

- ▶ 90°F Cooling setpoint (Adjustable)
- ▶ 55°F Heating setpoint (Adjustable)

5.3.2 Temperature Source Selection

The program will check for a valid source of temperature to control the unit. The software may be configured for the following four (4) available sources: ZS sensor (default), Remote sensor, BAS Sensor/Valve or the CAM built-in sensor.

5.3.2.1 ZS Sensor

The program will check for a valid 4-wire communicating ZS Sensor at the RNET port of the controller during the first 30 seconds after startup. If a valid sensor is not detected the unit will remain non operational in its default unoccupied state, an alarm is generated, and the program defaults to -60°F.

5.3.2.2 Remote Sensor

The program will check for a valid 2-wire, 10Kohm@ 77°F Thermistor type sensor at IN-2 of the controller during the first 30 seconds after startup. If a valid sensor is not detected the unit will remain non operational in its default unoccupied state, an alarm is generated, and the program defaults to -60°F.

5.3.2.3 BAS Sensor

The program will check for a network value pushed from the building automation system to control the unit. If no value is written to the network point the program defaults to 74°F, otherwise the last reported temperature value is used to control the unit. Refer to the Integration Points List for network points IDs.

5.3.2.4 CAM Sensor

The program will check for a network value from the Control Air M module. If no value is found the program defaults to 65°F.

5.3.3 Setpoint Management

While in the Auto mode (default), the registered zone temperature will be checked against the current set point range (Default: 70°F - 74°F occupied, 55°F - 90°F unoccupied). Manual offsets in the software or temperature adjustments from the ZS sensor will be taken into account when determining the actual setpoint range. Adjustment limits may be used to manage the allowed setpoint changes from the wall sensor (default limit is +/-3°F); for example, if the setpoint is increased in the space by 2°F, then the occupied setpoint range becomes 72°F - 76°F, and if the setpoint is decreased in the space by -2°F, then the occupied setpoint range becomes 68°F - 72°F. Upon a transition from occupied to unoccupied mode all setpoint adjustments are removed and reset to 0°F.

The software may be configured to disable the ability to change set points in the space.

5.3.4 Heating/Cooling Operation

The set points are compared to the effective zone temperature from the selected source. Demand, based on a PID Algorithm, is used to determine when to energize the unit in either heating or cooling mode. The PID algorithm calculates the demand value as a percentage (%) based on the difference between the zone temperature and the Heat/Cool set points.

5.3.4.1 Supply Fan

The supply fan will be started according to the schedule and is configured for continuous operation during the occupied mode (Fan On mode). The program may be configured to interlock fan operation with heating or cooling operations (Fan Auto mode). For this configuration the fan will be started if the PID demand for heating or cooling is greater than 10%, and stopped when the demand falls below 5%. After the supply fan has been started the control sequence will be enabled.

5.3.4.2 Compressors

The 1st Stage of compressor operation (Heating or Cooling) is enabled at 30% PID demand, and disabled at 20% PID demand.

Once enabled the compressor will cycle to maintain the zone temperature setpoint unless commanded off by a safety condition (e.g. smoke alarm, high/low leaving water temperature, etc.) or unit option (e.g. economizer, boilerless, loop valve, etc.).

The reversing valve is indexed on during cooling and indexed off during heating.

The stage 1 compressor will have a minimum OFF time of 3 minutes, and a minimum ON time of 7 minutes.

The second stage of compressor operation (heating/cooling) is enabled at 60% PID demand, and disabled at 40% PID demand. In addition, stage 2 compressor operation is only enabled after compressor stage 1 has been running for 7 minutes.

Once enabled the compressor will cycle to maintain the zone temperature setpoint unless commanded OFF by a safety condition (e.g. Smoke alarm, high/low leaving water temperature, etc.) or unit option (e.g. economizer, boilerless, loop valve, etc.).

To prevent short-cycling, the stage 2 compressor has a minimum OFF time of 5 minutes and no minimum ON time.

There will be a 1-minute delay when transitioning between heat and cool modes. The compressor will run subject to internal safeties and controls provided by the UPM. The compressors will not run if the fan is not operational.

A networked "loop valve enable" point must be enabled to allow compressor operation. This point is defaulted "ON" from factory.

When the zone is satisfied, the PID demand percentage will begin to decrease. Once demand falls below the thresholds described (20% for stage 1, 40% for stage 2) the compressor will be disabled. In addition, compressor stage 1 will be disabled 10 seconds after compressor stage 2 is disabled.

5.3.4.3 Night Setback

When this feature is enabled, the compressor will cycle as necessary to meet/maintain "unoccupied" temperature setpoints. A differential prevents the unit from cycling excessively. During unoccupied operation the fan will only cycle to maintain a heat or cool setpoint.

5.3.5 Unit Shutdown/Lockout

When the unit is shutdown by a smoke alert or emergency shutdown (network point) the unit will be set as follows:

- ▶ Supply fan will be off.
- ▶ Compressor(s) will be off.
- ▶ HGRH valve will be de-energized.

When the unit is locked out by a stop command or system safety the unit will be set as follows:

- ▶ Supply fan will remain energized (on) unless otherwise configured.
- ▶ Compressor(s) will be off.
- ▶ HGRH valve will be de-energized.

The following system safeties/conditions will result in a stop command:

- ▶ Leaving water temp high condition.
- ▶ Leaving water temp low condition.
- ▶ UPM reset command.
- ▶ Secondary drain pan (high condensate) alarm.
- ▶ Smoke event alarm.
- ▶ Differential pressure switch (DPS) alarm.

5.3.6 Options

5.3.6.1 Auxiliary Electric Heat

Electric heat (EH) option may be factory or field installed and must be configured by the equipment integrator. Only one (1) stage of auxiliary electric heat is supported and may be configured for BO-5. Upon a call for heating with demand greater than 90%(user configurable), the EH signal will be enabled to maintain setpoint at the configured outputs as follows:

- ▶ **Straight Cool Units:** enable with no delay.
- ▶ **Single-Stage Heat Pump Units:** Enabled 5 minutes after first stage of mechanical heat if demand is still above 90%.
- ▶ **Dual-Stage Heat Pump Units:** Enabled 5 minutes after second stage of mechanical heat if demand is still above 90%.

5.3.6.2 Hot Gas Reheat

Once the temperature setpoint has been satisfied and relative humidity is above setpoint, the unit will operate in hot-gas reheat mode to actively remove humidity from the space until the humidity setpoint has been satisfied, or there's another call for heating or cooling.

Relative humidity readings may be acquired from a space ZS Combo Pro or standard wall-mounted sensor, a 0-5V humidity sensor in IN-1/N-2, or over a network; software must be configured accordingly.

Humidity setpoint may be adjusted from a space ZS Pro sensor, network, or CAM/M+ interface.

5.3.6.3 Boilerless Control

Boilerless control (BLC) option must be configured by the equipment integrator. A factory installed entering water temperature sensor in IN-5 (IN-2 if IN-5 is unavailable) is used to enable boilerless control.

Entering water temperature values less than 40°F (user configurable) will enable boilerless control.

Compressor operation is disabled upon boilerless control signal being activated.

An Electric Heat Package must be installed for the boilerless control option. Electric heat will be enabled on output BO-5 or BO-4 for single stage units when boilerless signal is activated.

5.3.6.4 Economizer (Free Cooling)

Water-side economizer option must be configured by the equipment integrator. A factory installed Entering Water Temperature (EWT) sensor in IN-5 (IN-2 if IEM is present) is used to enable the economizer mode during cooling operations. Entering water temperature values below 55°F (user configurable) will enable economizer mode.

Once enabled, unit will run in economizer mode until the EWT exceeds 58°F (user configurable). A 3-way economizer valve is required for the WSE option and is connected to BO-5 or BO-4 for single stage units.

5.3.6.5 Condenser Water Valve

Factory installed loop valve with Valve End Switch (VES) option must be configured by the equipment integrator. Upon a call for compressor operation the normally closed valve is indexed to open via a 24Vac signal at BO-5. If the VES is configured, compressor operation is not enabled until valve end switch is engaged (valve fully open).

Valve open status is verified via the VES within 1.5 minutes of valve enable command.

If VES contacts do not engage within the specified time, VES fail alarm is initiated. If valve opens without command from BO-5, valve in hand alarm is initiated.

Compressor operation is disabled 20 seconds after VES opens (fails) when loop valve has been indexed to open.

5.3.6.6 Dirty Filter Switch

A field installed status switch is used to provide a contact closure at the configured input (IN-5 or IEM) when the filter is ready to be serviced. An alarm is generated immediately after the switch closes, and is available on a ZS Pro sensor, CAM/M+ interface, or over a network.

5.3.6.7 Smoke Detector Switch

A field installed smoke detector provides a contact closure at the configured input (IN-5 or IEM) during a smoke event, and will initiate emergency shutdown procedures after 5 seconds.

When the unit is shut down by the smoke detector the unit will be set as follows:

- ▶ Supply fan will be off (user configurable)
- ▶ Compressor(s) will be off.

The unit may be configured to operate the fan during a smoke event for specific safety applications; system integrator must determine the appropriate fan behavior.

5.3.6.8 Fan Status Switch

The status output from a factory-installed current sensor provides a contact closure at the configured input (IN-5 or IEM) to prove fan operation.

The fan command output is disabled if a contact closure is not detected and an alarm is generated 1 minute after the unit fan is indexed on by the controller.

5.3.6.9 Differential Pressure Switch

Differential Pressure Switch (DPS) option must be configured by the equipment integrator. A factory installed differential pressure switch is tied in to the controller at the configured input (IN-5 or IEM) and used to prove flow prior to unit compressor operation.

If the DPS opens during normal heating/cooling operation compressor operation is immediately ceased. If the switch remains open for more than 3 minutes an alarm is generated. Compressor operation is enabled (if a call still exists) once the switch closes, and the alarm is deactivated 5 seconds later.

5.3.6.10 Secondary Condensate Drain Pan

The Secondary Drain Pan (SDP) option must be configured by the equipment integrator. A factory installed SDP is tied in to the controller at the configured input (IN-5 or IEM) and used to monitor condensate levels.

If an open contact is detected at the controller input for more than 10 seconds during normal heating/cooling operation, compressor operation is ceased and an alarm is generated.

Normal compressor operation is restored once a contact closure is re-established at the input.

5.3.6.11 Outside Air Damper

Field installed outside air damper with Damper End Switch (DES) option must be configured by the equipment integrator. Damper may be indexed to open based on:

- ▶ **Occupancy:** Damper opens 10 seconds after unit enters occupied mode, and closes 2 minutes after unit leaves occupied mode.
- ▶ **Fan Operation:** Damper opens 10 seconds after fan is de-energized and running, and closes 2 minutes after fan is de-energized and remains off.
- ▶ **CO2 Levels:** Damper opens if zone CO2 levels exceed 1000PPM (user configurable) and closes 2 minutes after CO2 levels fall and stay below trip value.
- ▶ **Air Economizer:** Damper opens upon a call for cooling; if the outside air temperature and humidity fall within a user configured range (default: 50° F to 60° F OAT & 40 to 50% RH OARH), compressor operation is disabled and only the fan is used to condition the space. If space setpoint is not satisfied within 7 minutes of fan only operation, compressor(s) operation is enabled to provide additional stage(s) of cooling.

When DES is configured, compressor operation is not enabled until the switch is engaged (damper fully open).

Compressor operation is disabled 20 seconds after DES fails when damper has been indexed to open.

6 Water to Water Systems

6.1 DDC Options

6.1.1 Pump control

This option utilizes a field installed (optional) pump to move water to and from the heat pump co-axial cable. When there is a compressor call the controller will energize B0-1, which is connected to the pump. The controller can be configured to run the pump continuously or cycle with the compressor.

6.2 I/O Port Assignments And Overview

Universal Inputs				
Port	Inputs Accepted	Signal Type	Jumper Position	Overview
IN-1	Digital Input Enable	Dry	Top(W4)	This input is selected when a dry contact (e.g. room occupancy sensor) is required to enable the unit, and Digital Input has been selected for Occupancy Command. Unit is placed in occupied mode upon a contact closure at the input, and placed in unoccupied mode 10 minutes after the contacts reopen.
IN-2*	Load (Entering Water) Temperature Sensor	Therm	Top (W6)	This input is used to read the entering water temperature. Temperature sensor must be a stainless steel, Type II 10kohm @ 77°F(25°C) sensor, and mounted to load water pipe.
IN-3*	Leaving Water Temperature Sensor	Therm	n/a	A thermistor is wired to this input from factory to monitor leaving water temperature at the heat exchanger leaving water pipe. If the water temperature rises above 135°F (65°C) or drops below 35°F (1°C) for more than 5 minutes while the unit is running, compressor operation is halted and an alarm is generated. These temperature trip values are user adjustable.
IN-4*	UPM Input	Pulse	n/a	The Unit Protection Module (UPM) is standard on all FHP heat pumps. The alarm contacts of the UPM board are wired to the controller at this input from factory to transmit error pulse codes to the Control Air 5600. These alarm codes are then made available to view via a CAM/M+ interface, or over a network if one is available. Faults include: High Pressure, Low Pressure, High Condensate, Freeze Stat, and Brown out conditions.
IN-5	Change Over Temperature Sensor	Therm	n/a	When the unit is operating in the Auto Changeover mode a thermistor needs to be wired to this input to monitor the air temperature in the controlled zone. The unit goes into Auto heat or Auto cool based on the change over setpoint, 65°F (18°C) and the change over deadband 3°F (2°C). These values are user adjustable.
IN-6	Digital Input mode select	Dry	n/a	When operating in the Digital input mode, the unit will change from heat to cool or vice versa by using the state of this input. When the input is open (Off) the unit will heat and cool when the input is closed (On).

Table 10



*Non-configurable, factory assigned I/O parameter. All I/Os must be selected/configured in the software.

Universal Inputs				
Port	Inputs Accepted	Signal Type	Jumper Position	Overview
BO-1*	Pump	24VAC	G	<p>The unit can control a pump by using Digital Output 1 (BO-1) on controller; this feature can be enable or disabled, set to run with compressors or continuously during the commissioning process.</p> <ul style="list-style-type: none"> ▶ If commissioned to run continuously the pump will run when the unit is in occupied mode. ▶ If commissioned to cycle with compressors the pump will be commanded on only when the compressors are running. <p>The factory default is enabled to cycle with compressors.</p>
BO-2*	Reversing Valve	24VAC	O	<p>Binary Output 2 is factory reserved for the reversing valve command (O) and is wired to the valve via the unit terminal block in the electrical box. For heat pump units, the output is energized during a call for cooling, and remains de-energized for heating. For straight cool units (cooling only) where no reversing valve is installed, the output is disabled and not used.</p>
BO3*	Compressor Stage 1	24VAC	Y1	<p>Binary Output 3 is factory reserved for the compressor stage 1 command (Y1) and is connected to the UPM I board's "Y" terminal ("Y1" for dual compressor units using the UPM II board) via the unit terminal block in the electrical box. The Y1 output is off when the load temperature is within the temperature dead band (between heating and cooling setpoints). As the load temperature rises above the cooling setpoint plus the setpoint differential, Y1 is enabled. As the zone temperature drops below the heating setpoint minus the setpoint differential, Y1 is enabled.</p>
BO-4*	Compressor Stage 2	24VAC	Y2	<p>Binary Output 4 is factory defaulted for the compressor stage 2 command (Y2) and is connected to the second stage solenoid (Y2S) for 2-step, single compressors, or to the "Y2" terminal for dual compressor units using the UPM II board, via the unit terminal block in the electrical box. The Y2 output is off when the load temperature is within the temperature dead band (between heating and cooling setpoints). The Y2 output is energized after Y1 has been on for more than 7 minutes, and the load temperature either is greater than the cooling setpoint plus the setpoint differential plus a stage 2 cooling step or is lesser that the cooling setpoint minus the setpoint differential minus the stage 2 heating step. By default this step is 2, but it can be user configured.</p>

Table 11



*Non-configurable, factory assigned I/O parameter. All I/Os must be selected/configured in the software.

6.3 Sequence Of Operation

6.3.1 Unit Start Up

Program will check schedule status for either occupied or unoccupied mode to determined setpoint range. Different run conditions may determine the occupancy mode.

6.3.1.1 External Control Sources

Digital input

A contact closure (in IN-1) is used to enable unit operation. Once enabled, unit will run until set-point is satisfied, or 10 minutes has elapsed since contacts opened.

BAS

A network point is used to command the unit into occupied or unoccupied mode.

Manual on

The heat pump is placed in continuous run mode and will operate until setpoint is satisfied.

6.3.1.2 Internal Control Sources

Local Schedule

The internal scheduler uses the local time and user-defined schedule to determine occupancy.

Default schedule is:

Day of Week	Time	Mode
MON-FRI	8:00AM - 5:00PM	Occupied Mode
SAT	7:00AM - 3:00PM	Occupied Mode
SUN	10:00AM - 1:00PM	Occupied Mode

Table 12



Unit is in unoccupied mode outside the above stated hours.

Default Occupied Schedule Set Points:

- ▶ 54°F Cooling setpoint (Adjustable)
- ▶ 105°F Heating setpoint (Adjustable)

Default Unoccupied Schedule (Night Setback) Set Points:

- ▶ 74°F Cooling setpoint (Adjustable)
- ▶ 85°F Heating setpoint (Adjustable)

6.3.2 Setpoint Management

While in the Auto system mode (default), the registered load temperature will be checked against the current set point range. Manual offsets in the software will be taken into account when determining the actual setpoint range. Upon a transition from occupied to unoccupied mode all setpoint adjustments are removed and reset to 0°F.

6.3.3 Heating/Cooling Operation

The set points are compared to the effective load temperature. A simple comparator is used to determine when to energize the unit in either heating or cooling mode. If the load temperature is greater or lesser than the corresponding heat/cool threshold (setpoint + differential), a corresponding cool or heat demand is triggered.

6.3.3.1 Pump (Optional)

The unit can control a pump by using Digital Output 1 (BO-1) on controller; this feature can be enable or disabled, set to run with compressors or continuously during the commissioning process.

- ▶ If commissioned to run continuously the pump will run when the unit is in occupied mode.
- ▶ If commissioned to cycle with compressors the pump will be commanded on only when the compressors are running.

The factory default is enabled to cycle with compressors.

6.3.3.2 Compressors

The 1st Stage of compressor operation (Heating or Cooling) is enabled when the absolute difference between the setpoint and the load temperature exceeds the differential (default: 1F or 2C)

Once enabled the compressor will cycle to maintain the load temperature setpoint unless commanded off by a safety condition (e.g. high/low leaving water temperature, etc.).

The reversing valve is indexed on during cooling and indexed off during heating.

The second stage of compressor operation (heating/cooling) is enabled when the absolute difference between the setpoint and the load temperature exceeds the differential (default: 1F or 2C) plus a stage 2 step (default: 2). In addition, stage 2 compressor operation is only enabled after compressor stage 1 has been running for 7 minutes.

Once enabled the compressor will cycle to maintain the zone temperature setpoint unless commanded off by a safety condition (e.g. high/low leaving water temperature, etc.).

Lead - Lag Compressor operation



This feature is only available on two stage systems.

The unit will alternate the compressors by using Lead Lag control algorithm; the rotation method is user definable and can be set during the commissioning process as follows:

- ▶ Monthly
- ▶ Daily
- ▶ Time of Day

By default the unit will change its lead compressor if the one acting as lead fails.

6.3.3.3 Night Setback

When in “unoccupied” mode, the compressor will cycle as necessary to maintain the night setback load temperature at setpoint. A differential prevents the unit from cycling excessively.

6.3.4 Unit Shutdown/Lockout

When the unit is locked out by a stop command or system safety the unit will be set as follows:

- ▶ Pump will remain energized.
- ▶ Compressor(s) will be off.

The following system safeties/conditions will result in a stop command:

- ▶ Leaving water temp high condition.
- ▶ Leaving water temp low condition.
- ▶ UPM reset command.

7 ZS Combination Sensors



Supported only with Water to Air systems.

The Bosch line of intelligent zone sensors provides the function and flexibility needed to manage the conditions important to the comfort and productivity of the zone occupants. The ZS series are available in a variety of zone sensing combinations to address most application needs. These combinations include temperature, relative humidity, and carbon dioxide (CO2) for indoor air quality (IAQ) improvement. They are built to be flexible, allowing for easy customization of what the user/ technician sees. Designed to work with the DDC Control Air 5600, 5830, and 6120 controllers¹, the ZS sensor line includes the ZS Base, ZS Slidebar, ZS Push, and ZS Manager².

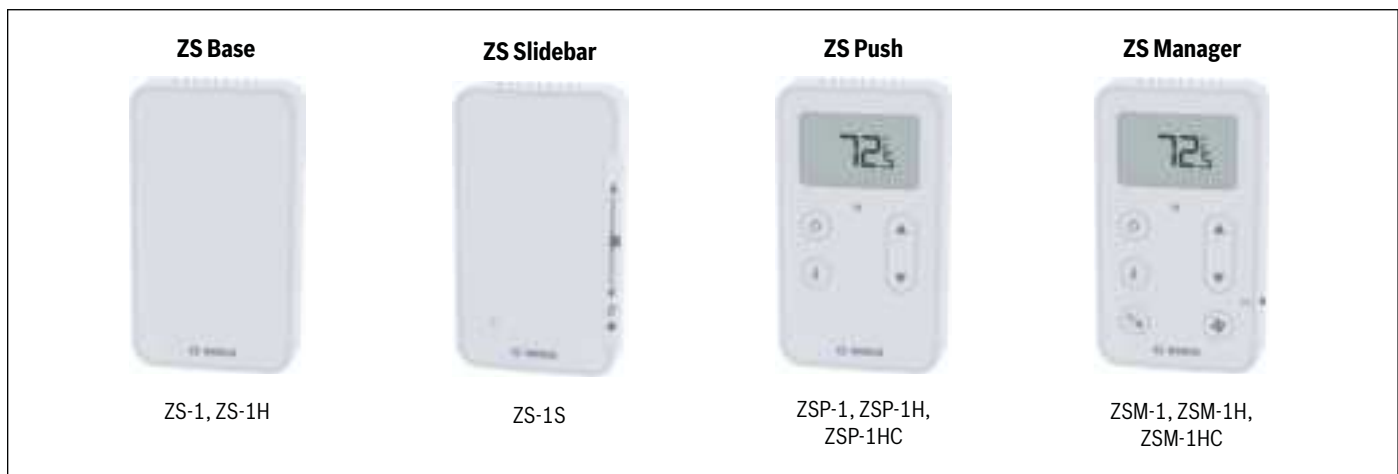

Figure 2 ZS Series Sensors

Features	Model								
	ZS-1	ZS-1H	ZS-1S	ZSP-1	ZSP-1H	ZSP-1HC	ZSM-1	ZSM-1H	ZSM-1HC
Part Number	8733951033	8733951034	8733951035	8733951036	8733951037	8733951038	8733951039	8733951040	8733951041
Temperature	•	•	•	•	•	•	•	•	•
Humidity		•			•	•		•	•
CO2						•			•
Neutral color	•	•	•	•	•	•	•	•	•
Addressable / supports daisy-chaining	•	•	•	•	•	•	•	•	•
Hidden communication port	•	•	•	•	•	•	•	•	•
Mounts on standard 2" x 4" electrical box	•	•	•	•	•	•	•	•	•
Occupancy status indicator			•	•	•	•	•	•	•
Push-button occupancy override			•	•	•	•	•	•	•
Set-point adjust			•	•	•	•	•	•	•
Large, easy-to-read LCD				•	•	•	•	•	•
Alarm indicator				•	•	•	•	•	•
Fan Mode Control (ON/AUTO)							•	•	•
System Mode Control (HEAT/COOL/AUTO/OFF)							•	•	•
°F to °C conversion button*							•	•	•

Table 13

¹ Previously known as FHP560, I/O Zone 583, and FLEX 6126 respectively.

² Previously known as ZS Base, ZS Plus, ZS Pro and ZS Pro-F respectively.

* Readout only.

7.1 Available Models

Sensor Model	Description	Bosch Part Number
ZS-1	Base Zone Temperature Sensor, no options	8733951033
ZS-1H	Base Zone Temperature Sensor, with humidity	8733951034
ZS-1S	Zone Temperature Sensor with override button, slidebar, occupied LED	8733951035
ZSP-1	Zone Temperature Sensor, Push Button with LCD display, no options	8733951036
ZSP-1H	Zone Temperature Sensor, Push Button with LCD display, with humidity	8733951037
ZSP-1HC	Zone Temperature Sensor, Push Button with LCD display, with humidity and CO2	8733951038
ZSM-1	Zone Temperature Sensor, Manager with LCD display, no options	8733951039
ZSM-1H	Zone Temperature Sensor, Manager with LCD display, with humidity	8733951040
ZSM-1HC	Zone Temperature Sensor, Manager with LCD display, with humidity and CO2	8733951041

Table 14

7.2 Specifications

Sensing Element	Range	Accuracy
Temperature (On Non-Humidity Models)	-4°F to 122°F (-20° C to 50°C)	±0.35° F (0.2° C)
Temperature (On Humidity Models)	50° F to 104° F (10° C to 40° C)	±0.5° F (0.3° C)
Humidity	10% to 90%	±1.8% typical
CO2	400 to 1250 PPM 1250 to 2000 PPM	±30PPM or +/-3% of reading (greater of two) ±5% of reading plus 30 PPM

Table 15

Power Requirements	Sensor Type	Power Required
Temperature Only	All Models	12Vdc @ 8mA
Temperature/CO2/ Humidity	All Models	12 Vdc @ 15 mA (idle) to 190 mA (CO2 measurement cycle)

Table 16

Power Supply

A controller supplies the Rnet sensor network with 12 Vdc @ 210 mA. Additional power may be required depending on the application.

Communication

115 kbps Rnet connection between sensor(s) and controller
5 sensors max per control program (5 sensors can be daisy-chained to one controller for power averaging)

Local Access Port

For connecting a laptop computer to the local equipment for maintenance and commissioning

Environmental Operating Range

32° to 122° F (0° to 50° C), 10% to 90% relative humidity, non-condensing

Mounting Dimensions

Standard 2" x 4" electrical box using provided 6/ 32" x 1/2" mounting screws

7.3 Features

The ZS Series Zone Sensors are thermistor-based, communicating temperature sensors that may optionally sense humidity or CO₂. The ZS Sensors are field installed and are wired to the Rnet port of the DDC Control Air 5600, 5830, or 6120 controller¹. A maximum of 5 ZS sensors may be daisy-chained and used for applications where averaging of multiple readings for temperature is required.

<p>ZS Base</p> 	<ul style="list-style-type: none"> ▶ Local access port ▶ No user control ▶ Available in: <ul style="list-style-type: none"> – Temperature only: ZS-1 (8733951033) – Temperature with Humidity: ZS-1H (8733951034)

Table 17



<p>ZS Sidebar</p> 	<ul style="list-style-type: none"> ▶ Slide potentiometer for temperature setpoint adjustment to make the zone warmer or cooler ▶  button to override the schedule and put the zone in an occupied state ▶ Green LED to indicate occupied state ▶ Local access port ▶ Available in: <ul style="list-style-type: none"> – Temperature only: ZS-1S (8733951035)

Table 18



Slide the sensor's potentiometer up to make the zone warmer or down to make it cooler. The control program determines how much you can adjust the set point (see figure 4).

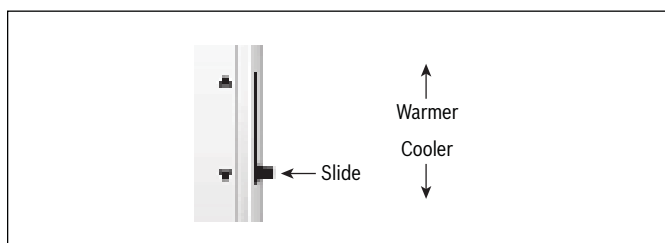

Figure 3





<p style="text-align: center;">ZS Push</p> 	<ul style="list-style-type: none"> ▶ LCD Display ▶  button to override the schedule and put the zone in an occupied state, or force the zone to an unoccupied state ▶  and  buttons to change any editable property, such as the temperature or humidity set-point. ▶  button to cycle through information defined in the control program (see Table 11 for more info) ▶ Green LED to indicate occupied state ▶ Local access port ▶ Available in: <ul style="list-style-type: none"> — Temperature only: ZSP-1 (8733951036) — Temperature with Humidity: ZSP-1H (8733951037) — Temperature with Humidity and CO2 : ZSP-1HC (8733951038)
--	--

Table 19







<p style="text-align: center;">ZS Manager</p> 	<ul style="list-style-type: none"> ▶ LCD Display ▶  button to override the schedule and put the zone in an occupied state, or force the zone to an unoccupied state ▶  and  buttons to change any editable property, such as the temperature or humidity set-point. ▶  button to cycle through information defined in the control program (see Table 11 for more info) ▶ Green LED to indicate occupied state ▶ Local access port ▶  button to select different system modes (Heat/Cool/Auto/Off). ▶  button to select between two modes of fan operation (Auto/On). ▶ Available in: <ul style="list-style-type: none"> — Temperature only: ZSM-1 (8733951039) — Temperature with Humidity: ZSM-1H (8733951040) — Temperature with Humidity and CO2 : ZSM-1HC (8733951041)
---	---

Table 20

7.4 Addressing Sensors

When multiple ZS Series Zone Sensors (up to 5 max) are connected to the DDC controller, each sensor on the Rnet must have a unique address associated with it, and the addresses have to be sequential. If the sensors are not addressed sequentially the DDC Controller reads any gaps as faulty sensors and a sensor wiring alarm is generated.

The DIP switches located at the back of the sensor (next to the Rnet connector block) may be used to set an address from 1 to 5 (the factory default address for all Bosch branded ZS Series sensors is "1").

There are four (4) DIP switches (numbered 1 through 4) used to address the ZS Series sensors. Each DIP switch has a value assigned to it for addressing the sensors as shown in the table

DIP Switch Number	DIP Switch Value
1	1
2	2
3	4
4	8

Table 21

Turn on as many DIP switches as needed so that their total value equals the required address. In the example shown in Figure 3, DIP switches #1 and #4 are ON (to the right position). Their values (1 + 8) total 9, so the sensor's address is 9.

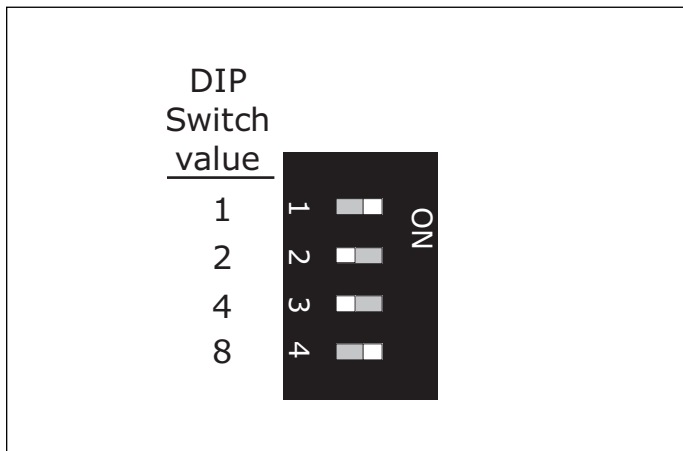

Figure 4

i While the DIP switches may be used to address the sensor for any value from 0 to 14, the DDC Control Air 5600, 5830, and 6120 controllers ONLY recognize values from 1 to 5, and any other address will result in the sensor(s) not functioning properly.

7.5 Multiple Sensors

Multiple ZS Series Zone Sensors on an Rnet must be configured in the software (using *Control Air M or M+ interface) in order for the DDC Control Air 5600, 5830, and 6120 to function as required.

Any combination of sensing capabilities may be used (Temperature, Relative Humidity, CO2), and the effective temperature value used to control the unit may be configured as the minimum, maximum, or average of all the individual values.



When connecting multiple sensors for temperature averaging, the master sensor (DIP switch value 1) should be a ZS Push/Manager, and any additional slave sensors should be ZS Base Temperature Only sensors.

7.6 Formatting Sensors

Formatting a sensor clears its flash memory. To format a sensor perform one of the two options below:

1. Download the controller that the sensor is connected to with new software using Apploder.

OR

2. Perform the following steps:
 - a. Remove the wiring connector from the sensor
 - b. Note the current position of the DIP switches
 - c. Set all DIP switches to the ON position
 - d. Reattach the wiring connector to format
 - e. After approximately 3 seconds, remove the wiring connector
 - f. Set the DIP switches back to their original position
 - g. Reattach the wiring connector

* To be released in 2018

7.7 ZS Push/Manager Sensors

The ZS Push and Manager Series Sensors can be ordered as temperature only, temperature with relative humidity, or temperature with relative humidity and CO2 . They are the most versatile of the the four sensor models, and are designed to work with the DDC Control Air 5600, 5830, and 6120 controllers.

The ZS Push and Manager Series Sensor allows the user to:

- ▶ View information in the display such as zone temperature, setpoints, outside air temperature, and equipment status
- ▶ Make the zone warmer or cooler by adjusting the setpoint. By default the DDC Control Air 5600, 5830, or 6120 only allows a temperature change of 3 degrees in either direction (cooler or warmer) but this value can be changed using the Control Air M or M+ interface, CAM, or from the BAS
- ▶ Adjust humidity setpoint when unit is equipped with hot gas reheat to control relative humidity in the space
- ▶ Override the schedule to put the zone in an occupied state (in increments of 30 minutes with a maximum override time of 3 hours)
- ▶ Force the zone to an unoccupied state
- ▶ See that the zone is in an occupied state when the green LED is lit.
- ▶ Alert residents in plain text of error and fault messages that require specific actions (e.g. change filter required). See Table 13
- ▶ See that the fan is running when the fan symbol is displayed on the screen
- ▶ Set System and Fan Modes (only on ZS Manager)

7.7.1 Navigating the Push/Manager Sensor’s Screens

The control program determines what screens you see, what information is in each screen, and what you can adjust. The type of sensor also determines what you see. For example, if the sensor reads temperature, humidity, and CO2 , the Home screen will cycle through the current values.

This Screen	Displays When
Home	The sensor has had no user interaction for 5
Set-point adjustment	You press the ▲ or ▼ button.
Information	You press the <i>i</i> button. Tap the button to cycle through various information.
Diagnostic	You hold the <i>i</i> button for 3 seconds. Tap the button to cycle through various information to troubleshoot the system.

Table 22

7.7.2 ZS Push Sensor Display













This Item	Indicates
F° or C°	The temperature is Fahrenheit or Celsius.
	The value shown is percent relative humidity.
	The value shown is outside air temperature or humidity.
	Cooling
	Heating
	The zone's fan is running.
	The fan mode is set to On.
	The value(s) in the display, typically setpoints, are editable using the ▲ and ▼ buttons. If the control program specifies that the value is not editable, you will see  without arrows."
	The sensor is in a timed override.
	The equipment is running in an energy-saving mode, or other mode defined in the control program.
	An alarm condition exists. The Information screen or Diagnostic Screen will provide details on the alarm.
	A maintenance condition exists. The Information screen or Diagnostic Screen will provide details on the maintenance condition.
	The sensor's buttons are locked either because the control program specifies it or because a user locked them at the sensor. See Figure 6 on how to unlock.
OCC	The displayed setpoint is an occupied setpoint.
UnOCC	The displayed setpoint is an unoccupied setpoint.
CO2	The value shown is CO2 .
A NUMBER IN THE BOTTOM LEFT CORNER	Rnet Tag: A value in the control program that does not have an associated icon. For example, 501 represents the zone mode status.

Table 23

7.7.3 Make the Zone Warmer or Cooler Using a ZS Push/Manager

1. From the Home screen, press the ▲ or ▼ button to show the Setpoint Adjustment screen. The screen shows the following: (Figure 5)

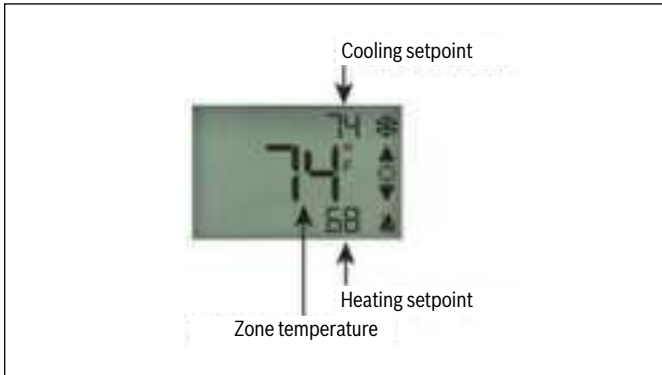

Figure 5

2. Press the ▲ or ▼ button to adjust the zone temperature setpoint. The control program determines how much you can adjust the setpoint and is default to +/- 3°F. The DDC Control Air 5600, 5830, or 6120 control program allows this adjustment value to be changed either using a Control Air M or M+ interface, CAM, or from an available BAS. The maximum allowable setpoint adjustment from the space is +/- 9°F.
3. Any setpoint adjustments made during an occupied session are cleared each time the unit transitions from occupied mode to unoccupied mode, and the setpoint adjustment remains at 0 until the next manual adjustments in the space.
4. Wait a few seconds until the display returns to the home screen before you press any other buttons

7.7.4 To Override the Schedule Using a ZS Push/Manager

Timed Override to an Occupied State

1. Press the ⏸ button one time to override the schedule and put the zone in an occupied state for a length of time specified in the control program.
2. Press the ⏸ button repeatedly to incrementally increase the time. The time increases in increments of 30 minutes and the maximum length of time that the override may be scheduled is 180 minutes (3 hours).
3. To cancel an override and return control to the schedule, press the ⏸ button twice.
4. Wait a few seconds until the display returns to the home screen before you press any other buttons.

During the override, the bottom of the display shows the time (minutes) remaining in the override and an hourglass to indicate the override state. (See Figure 6)



Figure 6

Force to an Occupied State

1. Press and hold the ⏸ button for 3 seconds to force the zone to an unoccupied state.
2. To cancel the force to unoccupied and return control to the schedule, press the ⏸ button again.

7.7.5 To Lock the Sensor Buttons of a ZS Push/Manager

Simultaneously press and hold the 2 buttons shown below (see Figure 7) for 5 seconds to lock the sensor's buttons. The display shows a lock icon to indicate the locked state.

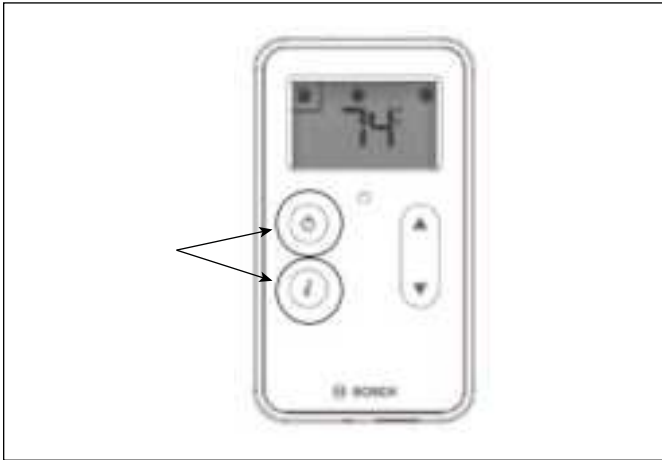



Figure 7



Press and hold the 2 buttons again for 5 seconds to unlock the buttons.



If you press the  button slightly before the  button, the sensor will go into an override state instead of locking the buttons. But, if you press the  button first, the buttons will lock.

7.7.6 To Edit Displayed Values Using a ZS Push/Manager

If the display shows a value other than a zone temperature setpoint with  to the right of it, the value is editable from the sensor. An example is the screen for the zone humidity setpoint. Access this screen by pressing the info button several times (approx 7 times) until the humidity setpoint is visible (Rnet tag 406), then follow the steps below to change the value as needed (max of 95%rh, min of 20%rh):

1. Press the  or  button to adjust the value.
2. Wait until the display returns to the home screen before you press any other buttons.



If the control program specifies that the value is not editable, you will see  without arrows.

7.8 Rnet Tags

Rnet tags are numbers that identify types of system values, and determine how the ZS Series sensor will display those values. For example:

- ▶ The Rnet tag number 416 indicates Air Flow Setpoint. Values such as this that do not have an icon will display the Rnet tag number in the lower left corner of the sensor's display. (see Figure 8)



Figure 8

Next page is a list of information provided by the ZS Push/Manager Sensor when the info button is pressed.

Press Info Button this number of times	Information Displayed	Rnet Tag Number	Read Only	Inactive Text	Active Text
1*	Occupied Cooling Setpoint	n/a	✓		
2	Occupied Heating Setpoint	n/a	✓		
3	Unoccupied Cooling Setpoint	n/a	✓		
4	Unoccupied Heating Setpoint	n/a	✓		
5	Effective Cooling Setpoint	n/a	✓		
6	Effective Heating Setpoint	n/a	✓		
7	Occupied Zone Humidity Setpoint	406	✓		
8	Outdoor Air Temperature (OAT)	300	✓		
9	Aux Heat Output Command	1102	✓	Off	On
10	Effective Discharge Air Temperature (DAT)	304	✓		
11	Leaving Water Temperature (LWT)	319	✓		
12	Current Alarm Condition/Code	1300	✓		
13	Zone Mode Status	501	✓		
14	Compressor Stage 1 Status	1100	✓	C1 Off	C1 On
15	Compressor Stage 2 Status	1101	✓	C2 Off	C2 On
16	Economizer Mode Status	116	✓	Econ Off	Econ On

Table 24

* If there's an active alarm(s) condition, pressing the info button once will first display the alarm page(s) including the corresponding Rnet tag and a short text, before resuming the regular cycle of functions.

Alarm conditions are indicated by the bell symbol appearing on the Pro sensor display (see figure 9).



Figure 9

The following is a description of the available alarm codes on the “Current Alarm Condition/Code” screen(Rnet tag 1300):

Alarm Code	Description
0	System Normal - No Alarms
1	UPM code for High Pressure on circuit #1 fault
2	UPM code for Low Pressure on circuit #1 fault
3	UPM code for High Pressure on circuit #2 fault
4	UPM code for Low Pressure on circuit #2 fault
5	UPM code for Water Coil Freeze on circuit #1 fault
6	UPM code for High Condensate fault
7	UPM code for Brownout fault
8	UPM code for Air Coil Freeze on circuit #1 fault
9	UPM code for Water Coil Freeze on circuit #2 fault
10	UPM code for Air Coil Freeze on circuit #2 fault
20	FHP560 Input/Output in MANUAL lock position
30	Wired Sensor Failure for ZS Sensor, DAT Sensor, LWT Sensor, Humidity Sensor or CO2 Sensor
40	High or Low Leaving Water Temperature (LWT) Condition
50	High or Low Zone Temperature Condition
60	High or Low Discharge Air Temperature (DAT) Condition
70	Filter or Compressor Runtime Alert
80	High or Low Zone Humidity Condition
90	High Zone CO2 Condition
100	Differential Pressure Switch (DPS) Open Condition

Table 25

If an alarm is generated for any of the below conditions, pressing the info button will show a Alarm Code Description short “active text” and Rnet tag:

Alarm Display Information	Rnet Tag Number	Active Text
Filter Change Status	1027	FILTER
Low Zone Temp Alarm	1026	Lo ZTp
High Zone CO2 Alarm	1043	HI CO2
High Zone Humidity Alarm	1044	HI RH
Low Zone Humidity Alarm	1045	Lo RH
Compressor1 Runtime Alarm	1050	C1 RT
Compressor2 Runtime Alarm	1051	C2 RT
High Discharge Air Temp Alarm	1028	Hi DAT
Low Discharge Air Temp Alarm	1029	Lo DAT
Manual I/O Lock Alarm	1116	IO OVRD
Wired Sensor Failure Alarm	1115	SEN Conn
High Leaving Water Temp Alarm	1113	Load H2O
Low Leaving Water Temp Alarm	1114	Load H2O
High Zone Temp Alarm	1025	Hi ZTp
DPS Lock Alarm	1117	dPS
UPM General High Pressure Alarm	1118	HP Fault
UPM General Low Pressure Alarm	1119	LP Fault
UPM General Freezestat Alarm	1120	Frz stat
UPM Brownout BRN Alarm	1109	Brn Out
UPM Condensate COND Alarm	1108	Hi Cond

Table 26

7.8 Wiring and Mounting a ZS Sensor

The Rnet cable is wired to the controller at the Rnet connector. The shield wire (if available) and the ground wire should be inserted into the controller's GND terminal.

1. Turn off the controller's power.
2. Pull the back plate off the ZS Sensor. You may need to turn the setscrews in the bottom of the sensor clockwise until you can remove the back plate.
3. Pull the Rnet communication cable through the slit in the insulated backing material. (See Figure 10)

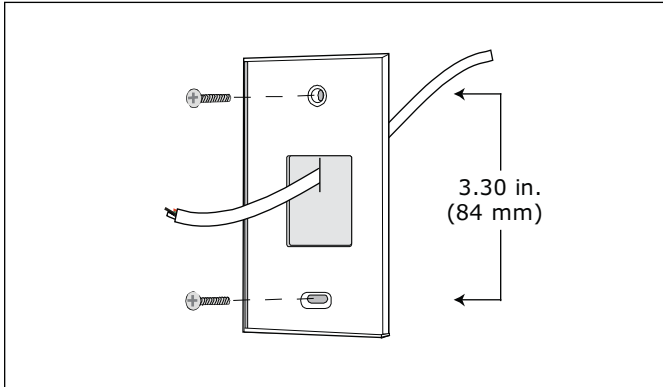

Figure 10

4. Use 2 screws to mount the back plate to the wall or outlet box.
5. Partially cut, then bend and pull off the outer jacket of the Rnet cable(s). Do not nick the inner insulation. (See Figure 11)

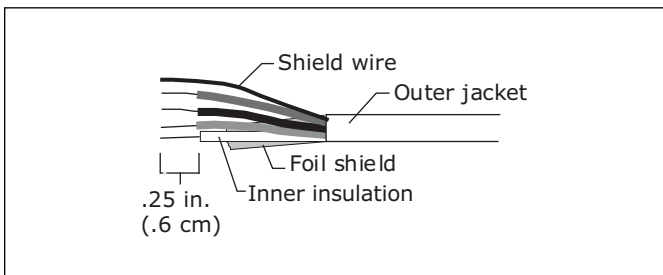

Figure 11

6. Strip about .25 inch (.6 cm) of the inner insulation from each wire.
7. If wiring 1 cable to the ZS Sensor, cut the shield wire off at the outer jacket, then wrap the cable with tape at the outer jacket to cover the end of the shield wire.
8. Insert the other 4 wires into the ZS Sensor's screw terminal connector. If wiring 2 cables, insert like colored wires into each terminal.

Connect this Wire	To this Terminal
RED	+12v
GREEN	Rnet-
WHITE	Rnet+
BLACK	Gnd

Table 27 Recommended Wiring Scheme for Rnet

NOTICE:

- ▶ Allow no more than .06 inch (1.5mm) of bare communication wire contacts to avoid touching the cable's foil shield wire, or a metal surface other than the terminal block. The device may not communicate correctly otherwise (See Figure 12).

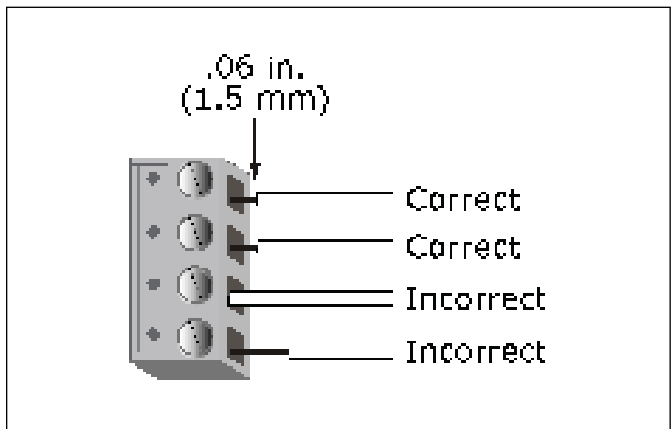

Figure 12

9. Attach the sensor's cover and circuit board to the mounted back plate, inserting the top first.
10. Turn the setscrews one full turn counterclockwise so that the cover can not be removed.

i Use the same polarity throughout the Rnet.

8 Control Air M/M+

8.1 The Control Air M/M+ Interfaces

The Control Air M and M+ (M=Manager) is a Human-Machine Interface (HMI) that interfaces with the BOSCH DDC Control Air 5600, 5830, and 6120 controllers, enabling the user to view and change property values, and/or control parameters, to match a corresponding application whether it is a Water to Air or Water to Water Heat Pump. It also provides a means of accessing and modifying the controller's schedule and real time clock in applications where a system server or Building Automation System (BAS) is not available. The Control Air M is designed for applications where there is one (1) WSHP. The Control Air M+ is designed for applications where there is up to fifty (50) WSHP's (existing networks only).

The software is normally configured at the factory to match the unit configuration, however, there are cases where additional on-site changes need to be made and this screen will allow the qualified technical or commissioning agent to incorporate such changes (without having to download a different software application) via the commissioning tool. The interface is offered in two forms: as a wall mount or unit mounted Control Air M/M+ module or in the form of an APP called the Equipment Touch (OEM), which can be found in the Google Play Store (Android Only).

8.2 The Control Air M/M+ Module

The Control Air M/M+ module (Figure 1) is a touchscreen device with a 4.3" color LCD display that you connect to either a Control Air 5600, 5830, or 6120 controller to view or change its property values, schedule units, view trends and alarms, and more. The unit connects to the controller via the onboard serial port. The module can be purchased by the following part numbers:

- ▶ Control Air M (8733951042)
- ▶ Control Air M+ (8733951043)
- ▶ Connecting Cable (Virtual Control Air M/M+ only) (8733908163)

The module is compatible with the following controllers: Control Air 5600, Control Air 5830, and Control Air 6120.

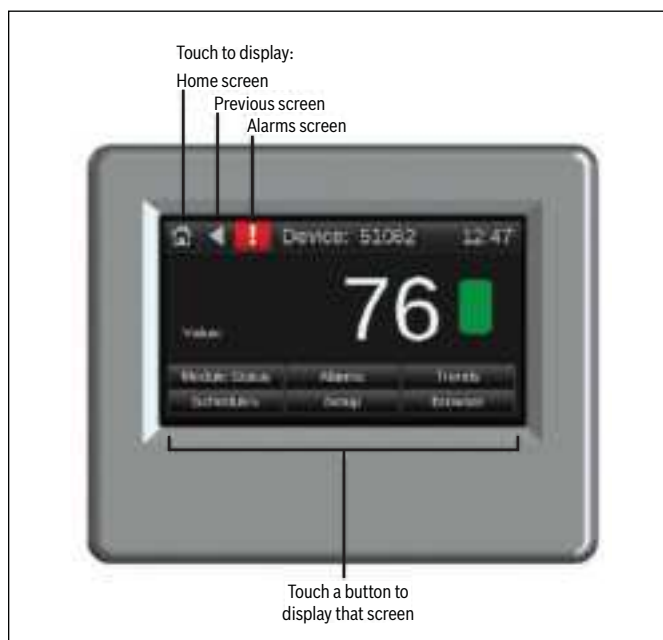

Figure 13

8.3 Virtual Control Air M/M+ (Equipment Touch (OEM) APP)

Virtual Control Air M/M+ (see Figure #2) provides the end-user an interface to a controller by way of an Android Tablet and a purchased USB-L cable (8733-927-403). The adapter; USB to micro USB (not provided by BOSCH) may be needed if USB port is not available on Android device. This adapter, not provided by Bosch, needs to be a female USB to male micro USB. Once the cables are purchased, the corresponding driver will need to be downloaded and installed before using the application. The USB or micro USB end of the cable is connected to the Android device, and the serial end is connected to the DDC controller, RS Sensor, or ZS Sensor. The Control Air M/M+ cable driver, and instructional manual are all available for free download at the Bosch Thermotechnology website.



CAUTION: FIRE, INJURY HAZARD

- ▶ When working on equipment, always observe precautions described in the literature, tags, and labels attached to the unit. Follow all safety codes. Wear safety glasses and work gloves. Use a quenching cloth for brazing, and place a fire extinguisher close to the work area.



Figure 14

8.4 Control Air M/M+ Specifications

Description	Value
Power	24 Vac (+/-15%), 5 VA, 50-60 Hz, Class 2
Backlit LCD display	4.3" resistive touchscreen color LCD display with backlighting WQVGA 480x272 px
Cable	6 ft. (1.8 m) cable to connect to controller's Local Access port.
Communication	Rnet: 2-wire EIA-485 port for connection to the Rnet sensor network (115 kbps)
Memory	<ul style="list-style-type: none"> — 16 MB Flash memory to store screen file. — 1.5 MB RAM to store variable data and LCD data. — 4 KB Serial EEPROM to store non-volatile configuration data.
Operating Range	-4° to 140°F (-20°C to 60°C), 10%-90% RH noncondensing
Overall dimensions	<ul style="list-style-type: none"> — Width: 5-7/16 in. (138mm) — Height: 4-1/16 in. (116mm) — Depth: 1-3/8 in. (30mm)
Weight	0.54 lbs (0.24 kg)
Listed by	UL-916 (PAZX), CE, FCC Part 15-Subpart B-Class A
Temperature Sensor	<ul style="list-style-type: none"> — Range @ 95% RH: -4°F to 140°F (-20°C to 60°C) — Range @ 20% RH: -4°F to 194°F (-20°C to 90°C) — Accuracy @ 25°C: ±0.4°C — Accuracy over 20°C to 30°C: ±0.5°C — Accuracy over 10°C to 45°C: ±1.0°C — Accuracy over full range: ±2.5°C — Resolution: 0.01°C
Humidity Sensor	<ul style="list-style-type: none"> — Range: 0 to 100% RH — Accuracy over 20 to 80% RH: ±3.0% RH — Accuracy over full range: ±5.0% RH — Resolution: 0.05 RH

Table 28 Specifications

8.5 Wiring

The Control Air M communicates through a Rnet connection. The Control Air M is intended for 1 HMI to 1 WSHP. It can be wired using the instructions in section 6. The Control Air M+ communicates through a BACnet MS/TP connection. The Control Air M+ is intended for 1 HMI to up to 50 WSHP's on an existing network.

8.5.1 Recommended Wiring Scheme

Connect this wire:	To this terminal on the Control Air M:
Red	24 VAC (R)
Black	24 VAC (C)
White	Rnet+
Blue	Rnet-

Table 29 Power Wiring

2-conductor wire 18 AWG for distances up to 100 feet. All transformer secondaries must be grounded. Wiring connections must be in accordance with NEC and local codes. All wiring and mounting screws must be field supplied.

8.5.2 Rnet Wiring Specifications

NOTICE:

- ▶ Use the specified type of wire and cable for maximum signal integrity.

Description	Value
Cable	4 conductor, unshielded, or unshielded CMP, plenum rated cable
Conductor	22 AWG (7x0096) bare copper
Maximum length	500 feet (152 meters)
Recommended coloring	Jacket: White
UL temperature	32–167°F (0–75°C)
Voltage Limited Listing	300 VAC, power UL: NEC CL2P, or better
Insulation	Low-smoke PVC (or equivalent)
Color Code	Black, white, green, red
Shielding	If shielded, Aluminum/Mylar shield (100% coverage) with TC drain wire

Table 30

8.6 Connection

8.6.1 Communicate Using a Tablet Through Virtual Control Air M and M+

In lieu of using the module to interface with the controller, a connection may be established at the local access port of the controller (or at the access port of a ZS Combo Sensor connected to the controller), to perform test and balance operations or to make changes to any device on the network.

8.6.2 To Wire and Mount the Control Air M/M+

11. Remove the backplate from the Control Air M/M+
 - a. Hold the Control Air M/M+ as shown in the picture below.
 - b. While firmly pressing the 2 tabs on top of the Control Air M/M+, pull on the backplate with your index finger until the backplate releases from the Control Air M/M+.



Figure 15

2. Pull the communication cable, power cable, and external thermistor wiring (if applicable) through the large hole in the center of the backplate. See figure in step 5.
3. Partially cut, then bend and pull off the outer jacket of the Rnet cable(s). Do not nick the individual wire insulation.
4. If wiring 1 cable to the Control Air M/M+, cut the shield wire off at the outer jacket, then wrap the cable with tape at the outer jacket to cover the end of the shield wire. If wiring 2 cables in a daisy-chain configuration, twist together the shield wires, then wrap the shield wires with tape.
5. Strip about 0.25 inch (0.6 cm) insulation from the end of each wire.
6. Connect wiring to the Control Air M/M+ as shown in Figure 6.

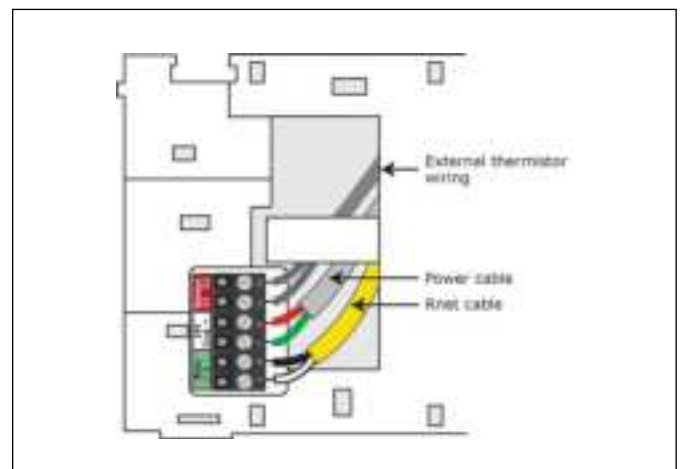

Figure 16

NOTICE:

- ▶ Allow no more than 0.06 inch (1.5 mm) bare communication wire to protrude. If bare communication wire contacts the cable's foil shield, shield wire, or a metal surface other than the terminal block, the device may not communicate correctly.

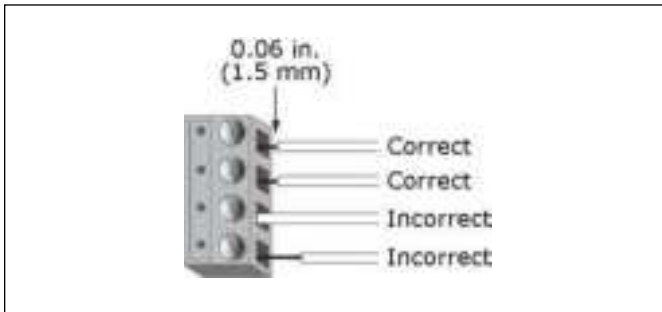

Figure 17

7. Attach the backplate to the wall or panel. If mounting in or on a panel:
 - a. Drill two 3/16 inch (4.8 mm) pilot holes in the panel.
 - b. Attach backplate using pan head 6-32 x 3/8" to 1/2" long machine screws. Do not overtighten screws to prevent damage to plastic housing.

i It is recommended to use Loctite 220 on screw threads if the Control Air M/M+ will be subject to vibration.

8. Attach the Control Air M/M+ to the backplate:
 - a. Place the bottom of the Control Air M/M+ onto the backplate by aligning the 2 slots on the Control Air M/M+ with the tabs on the backplate.
 - b. Push the Control Air M/M+ onto the backplate until the tabs at the top of the Control Air M/M+ snap onto the backplate.
9. Turn off the controller's power.
10. Connect the other end of the Rnet wiring to the controller's Rnet port or to a zone sensor.

i - Insert the shield wire with the ground wire into the controller's GND terminal.
 - Use the same polarity throughout the Rnet or MS/TP.

11. Connect power wiring to a 24 Vac power supply.
12. Turn on the controller's power.

8.6.3 Additional Information on Connecting Control Air M/M+ to a Controller

Connect the Control Air M/M+ module (or Android tablet if using Virtual Control Air M/M+) to the serial port on the DDC controller as indicated below, or to a ZS wall-mounted sensor connected to the controller (Virtual Control Air M/M+ only).

**CAUTION: FIRE, INJURY, ELECTRIC SHOCK HAZARD**

- ▶ If the equipment is used in a manner not specified by the manufacturer, the protection provided by the equipment may be impaired.

Mounting

The Control Air M/M+ must be mounted within the building interior. You can mount the Control Air M/M+:

- ▶ In a panel with the controller or on the panel door
- ▶ On a wall up to 500 feet from the controller

Wiring

The Control Air M/M+ requires a 24 Vac power supply. It is not powered by the Rnet.

**CAUTION: ELECTRIC SHOCK HAZARD**

- ▶ The Control Air M/M+ can st1 are a power supply wit11 the DDC controller as long as you:
 1. Maintain the same polarity.
 2. User the power supply only for DDC controllers.

You can also wire an external 10 kOhm, Type II thermistor to the Control Air M/M+. See External sensor resistance requirements (Table 6, page 14).

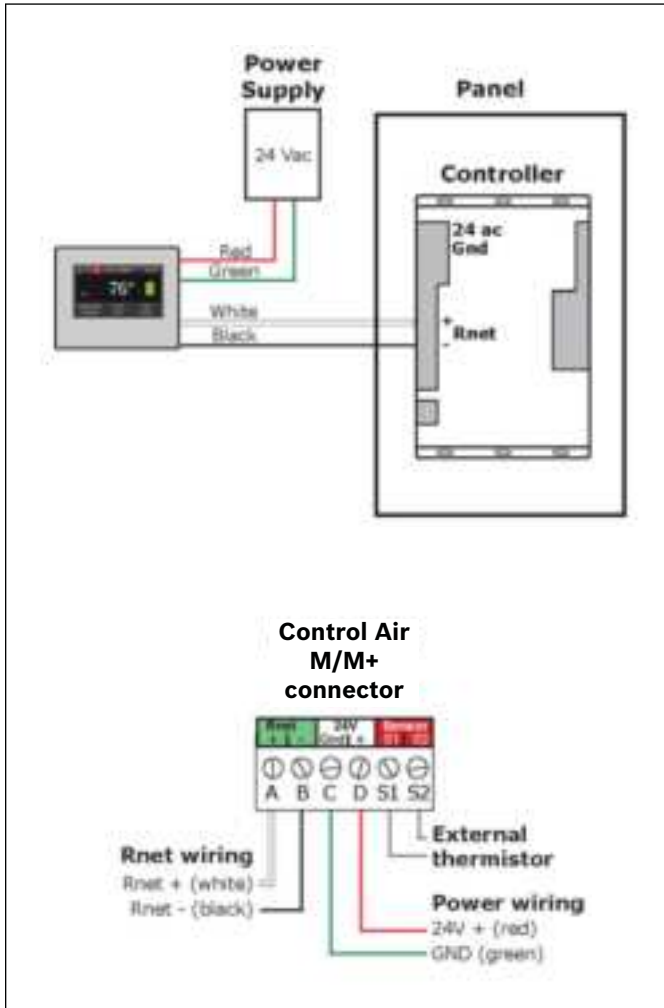

Figure 18

Establishing Communication

Plug the USB-L cable to the USB (Bosch part number 8733-927-403) to USB micro adapter (field supplied) and then to the Android tablet and controller before launching Virtual Control Air M/M+ (Equipment Touch (OEM) app). The DDC controller must be connected to a 24 VAC source and powered on.

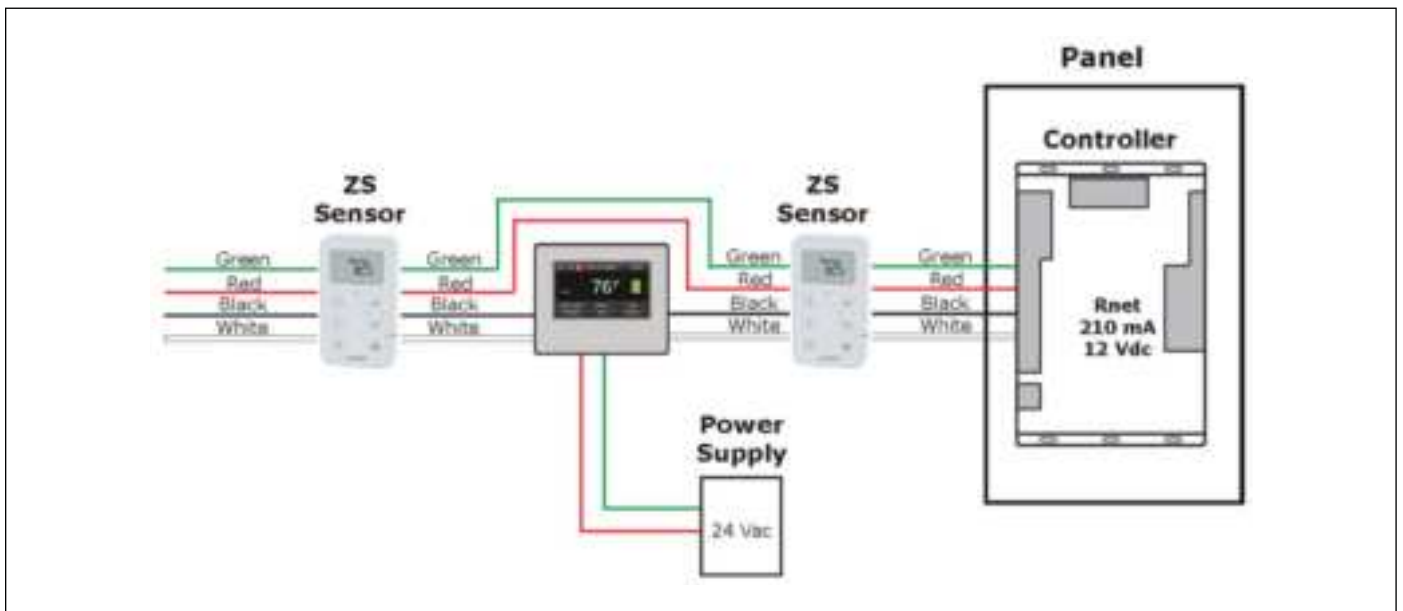
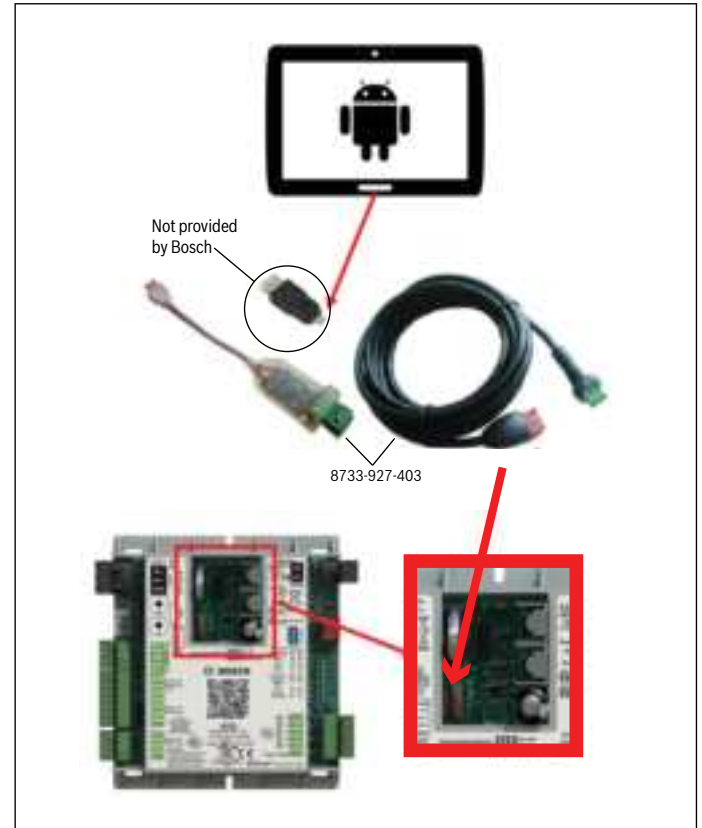

Figure 19

9 Troubleshooting

9.1 Control Air 5600

Most technical issues regarding the Control Air 5600 may be resolved by following these 5 steps:

1. Ensure the jumpers located in the cut-out of the controller are set correctly:
 - IN-1/IN-2 jumpers are used to assign Dry/Therm or 0-5Vdc status per input and should be set accordingly
 - The communications selection jumper must be in the top position for all jobs, except when BACnet over ARC156 is used.
2. Ensure DIP switches are set properly to match the communication protocol (Lon, N2, Modbus, BACnet over MS/TP) and baud rates. Jobs networking over Lon must include the Lon Card (purchased separately).
3. Ensure rotary dials on a network are unique and set properly; 10's digit using top dial, 1's digit using bottom dial.
4. Ensure all wiring is secure and up to code per the wiring diagram(s) and specifications.
5. If the software becomes corrupted the controller may be reset to the last saved/archived version by performing the following:
 - a. Remove the 24Vac power from the controller
 - b. Pull the 3V CR2032 onboard battery from the controller
 - c. Replace the onboard battery after approx 10 seconds
 - d. Reconnect the unit 24Vac power

9.2 ZS Sensors

The following technical issues may be resolved as described below when using ZS sensors:

If Display Shows.	Then...
Nothing	The sensor has no power. Verify 24Vac power to the DDC controller and 12Vdc power to the sensor.
	<p>The sensor is not communicating with the network. Verify the following:</p> <ul style="list-style-type: none"> ▶ Addressing setup may be incorrect. The DIP switches at the back of the sensor must be set to 1 if connecting only one sensor to the controller, or 1 through 5 in sequential order if daisy-chaining multiple sensors to the controller. ▶ Wiring connections may be inaccurate. Verify sensor is wired as specified under the "Wiring and Mounting" section of this document, and that all conductors are secure and continuous. ▶ The DDC Control Air 5600, 5830, or 6120 controllers software may be corrupted. Verify controller operating status and perform battery reset if needed (see Section 10.1 Battery Reset). ▶ Control program may not support ZS Series Zone Sensors. Use a Control Air M, M+ interface to verify that software version for the DDC controller.
Characters that seem out of place or jumbled	The sensor has a memory problem. Try formatting the sensor per the instructions provided in this document (see Section 8 Formatting Sensors).
Bogus values (-999) displayed for RH and/ or CO2	<p>The sensor hardware is not capable of reading RH and/or CO2 values. Perform the following steps to omit bogus values from the sensor screen:</p> <ul style="list-style-type: none"> ▶ If connecting sensor to the DDC controller for the very first time, ensure that the sensor is connected to the controller R-net port then apply power (24Vac) to the controller. ▶ Configuration to eliminate bogus values begins and is completed approximately 45 seconds later. ▶ With sensor still connected to the controller, remove the unit 24Vac power from the controller for about 5 seconds, and then reconnect power.

Table 31

9.3 Communication LED's

LEDs	Status
Power	Lights when power is being supplied to the controller.
Rx	Lights when the controller receives data from the network segment; there is an Rx LED for Ports 1 and 2.
Tx	Lights when the controller transmits data from the network segment; there is an Rx LED for Ports 1 and 2.
Run	Lights based on controller health.
Error	Lights based on controller health.

Table 32

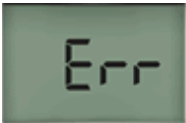
If Run LED shows...	And Error LED shows...	Status is...
1 flash per second	1 flash per second, alternating with the Run LED	The controller files are archiving. Archive is complete when Error LED stops flashing.
2 flashes per second	Off	Normal
2 flashes per second	2 flashes, alternating with Run LED	Five minute auto-restart delay after system error
2 flashes per second	3 flashes, then off	The controller has just been formatted
2 flashes per second	4 flashes, then pause	Two or more devices on this network have the same BACnet network address
2 flashes per second	On	<p>Exec halted after frequent system errors, due to:</p> <ul style="list-style-type: none"> ▶ The controller halted ▶ Program memory corrupted ▶ Address conflicts ▶ One or more programs stopped
5 flashes per second	On	Exec start-up aborted, Boot is running
5 flashes per second	Off	Firmware transfer in progress, Boot is running
7 flashes per second	7 flashes per second, alternating with Run LED	Ten second recovery period after brownout
14 flashes per second	14 flashes per second, alternating with Run LED	Brownout
On	On	<p>Failure. Try the following solutions:</p> <ul style="list-style-type: none"> ▶ Turn the controller off, then on. ▶ Format the controller. ▶ Download memory to the controller. ▶ Replace the controller.

10 Physical Dimensions and Specifications

10.1 Control Air 5600 Controller Dimensions

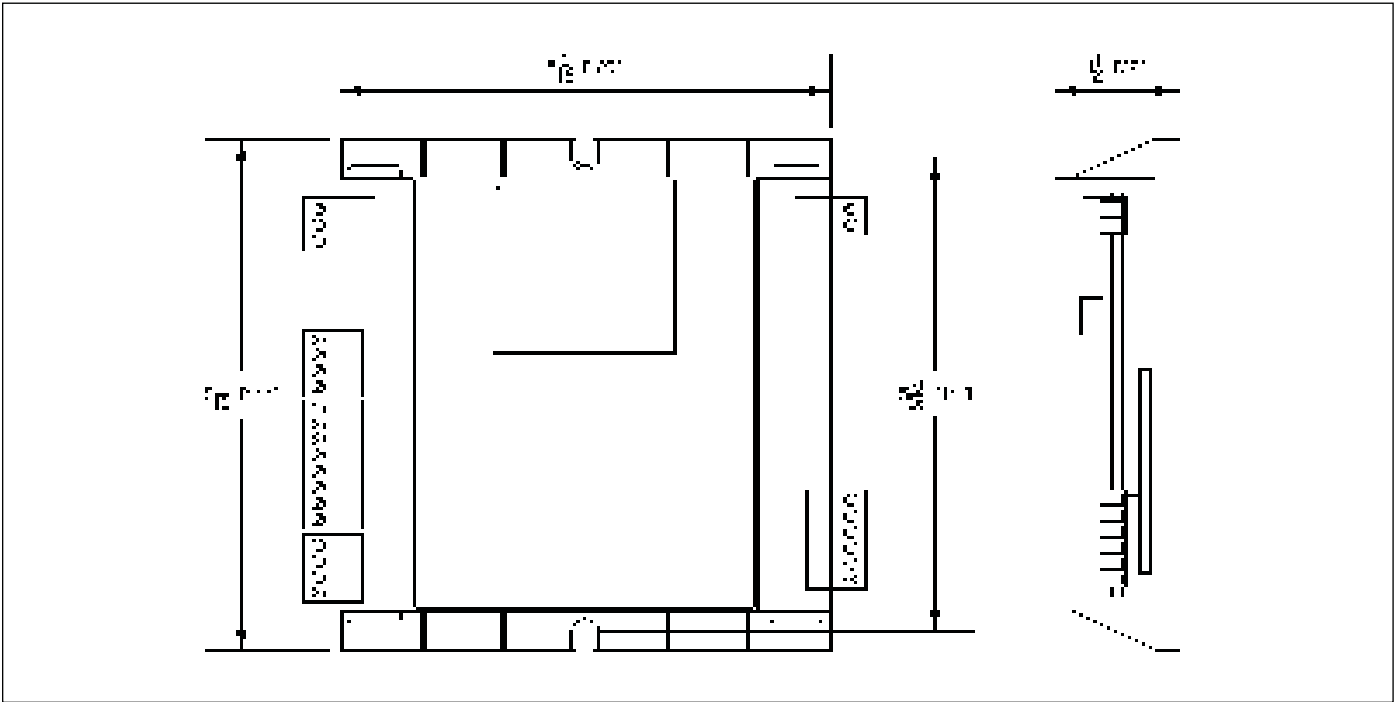

Figure 20

10.2 Input Expansion Module (IEM) Features

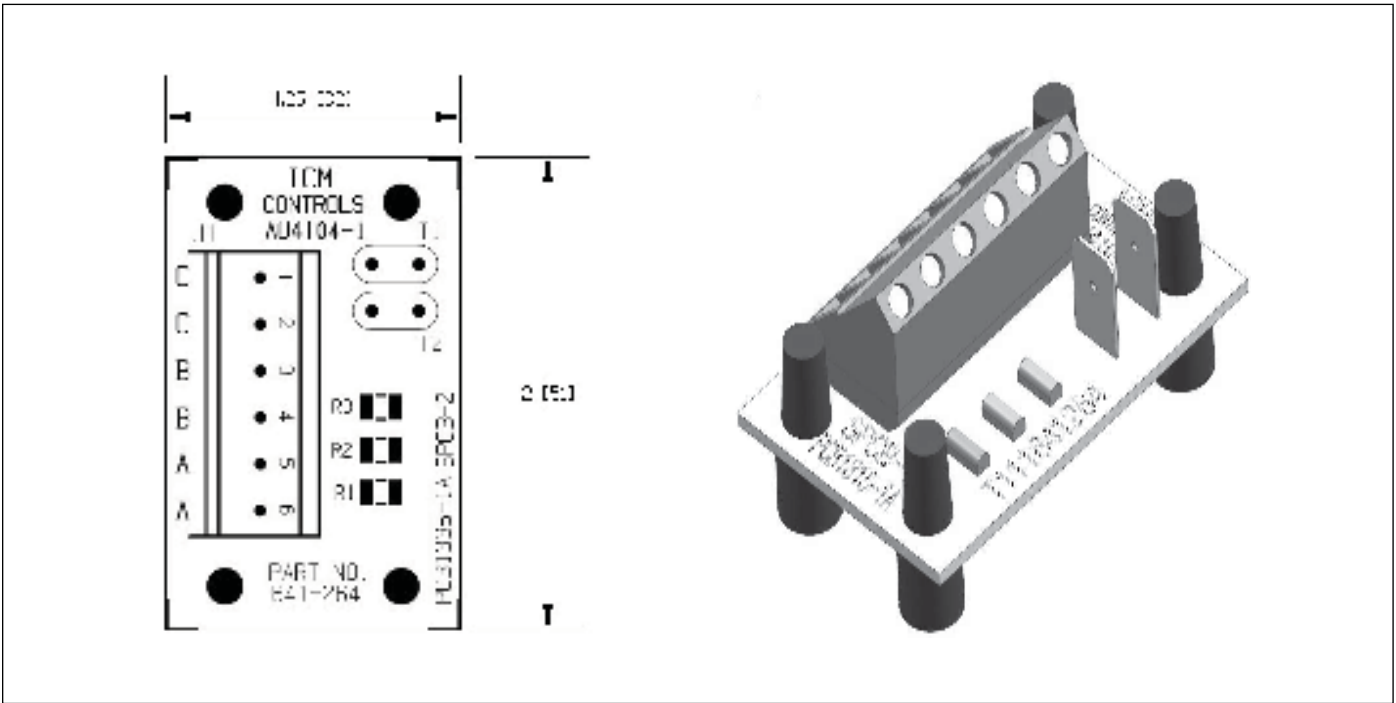

Figure 21

i Primary Units: Inches
Secondary Units: Millimeters

10.3 Control Air M/M+ Dimensions

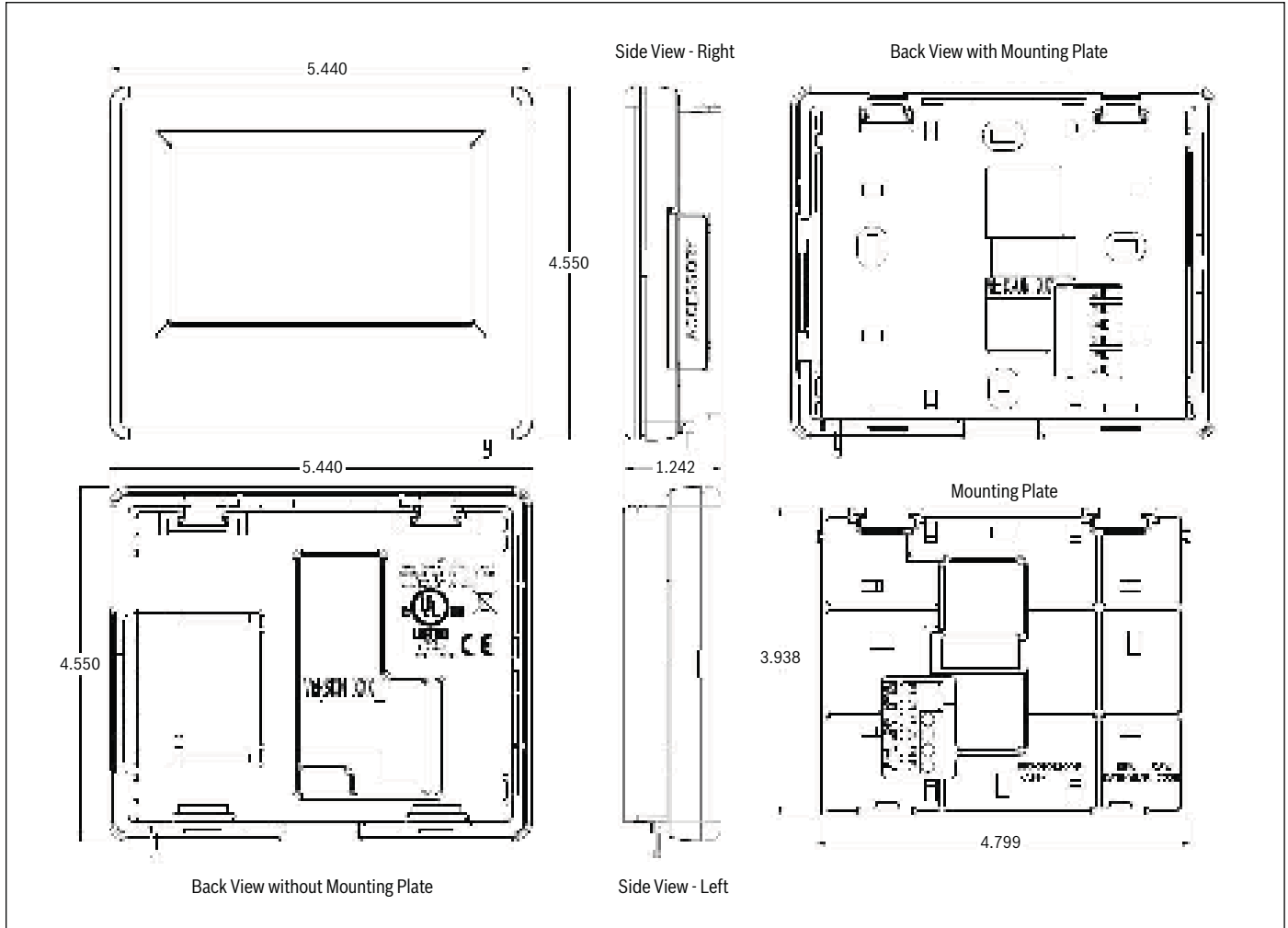

Figure 22

Control Air M/M+ Module Termination Details

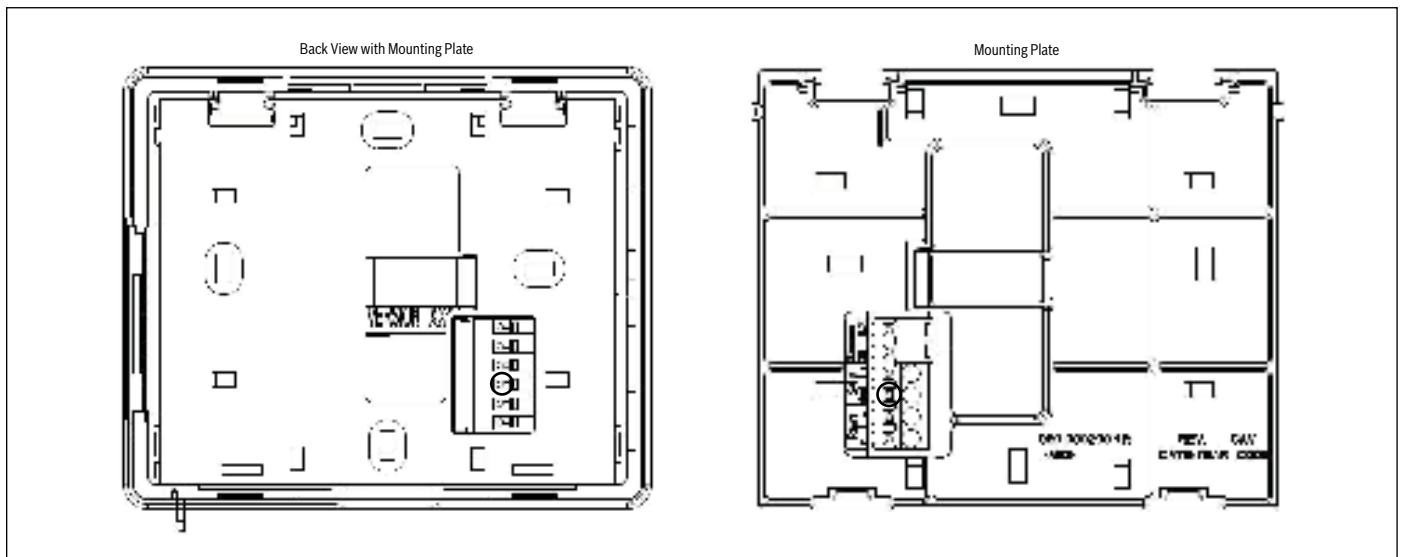

Figure 23

10.4 ZS Series Zone Sensor R1 Dimensions

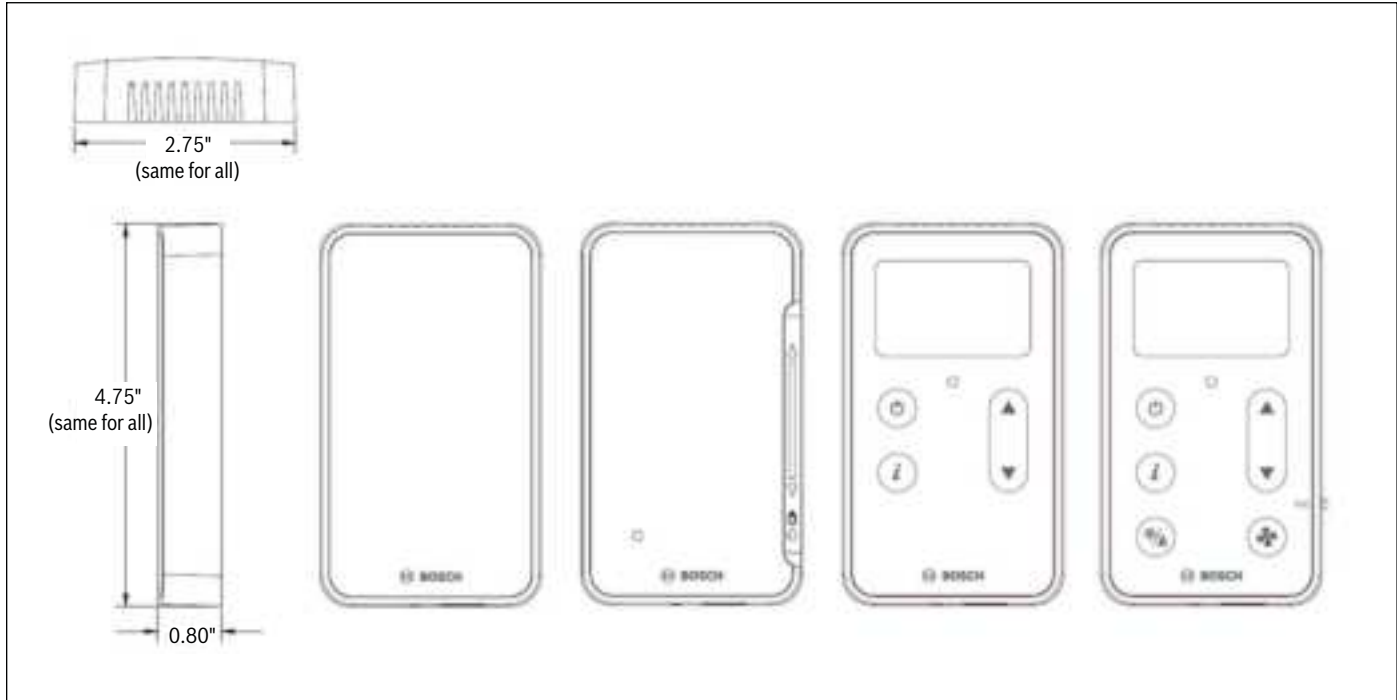

Figure 24

10.5 Wiring Termination Specs

<p>BINARY OUTPUT (BO) 1</p>	<p>BINARY OUTPUT (BO) 2</p>	<p>BINARY OUTPUT (BO) 3</p>	<p>NOTES:</p> <p>1 ONLY IN-4 OF THE FHP560 IS USED FOR PULSE READINGS FROM THE UPM.</p> <p>2 ONLY IN-1 & IN-2 MAY BE CONFIGURED FOR 0-5V SIGNALS.</p> <p>3 FHP560 BO CONTACT RATINGS: 1A MAX @ 24VAC/DC CONFIGURED NORMALLY OPEN</p> <p>4 MAXIMUM RECOMMENDED CABLE LENGTH FOR INPUTS: 500'[152m] WITH 22 AWG.</p> <p>5 WHEN SIZING OUTPUT WIRING CONSIDER THE FOLLOWING:</p> <ul style="list-style-type: none"> TOTAL LOOP DISTANCE FROM POWER SUPPLY TO FHP560, THEN TO THE CONTROLLED DEVICE. ACCEPTABLE VOLTAGE DROP FROM THE FHP560 TO CONTROLLED DEVICE. RESISTANCE OF WIRE GAUGE USED. MAX AMPS REQUIRED BY CONTROLLED DEVICE TO OPERATE.
<p>DIGITAL INPUT (DI) DRY CONTACT 1</p>	<p>DIGITAL INPUT (DI) DRY CONTACT 2</p> <p>NOTE: ONLY UI-4 IS USED FOR A PULSE ACCUMULATING POINT</p>		
<p>ANALOG INPUT (AI) 0-5 VDC</p> <p>NOTE: ONLY UI-1 & UI-2 CAN BE USED FOR 0-5VDC</p>	<p>ANALOG INPUT (AI) 10Kohm RTD</p>	<p>ANALOG INPUT (AI) 0-5 VDC</p> <p>NOTE: ONLY UI-1 & UI-2 CAN BE USED FOR 0-5VDC</p>	

Figure 25

11 Electrical Schematics

11.1 Water to Air

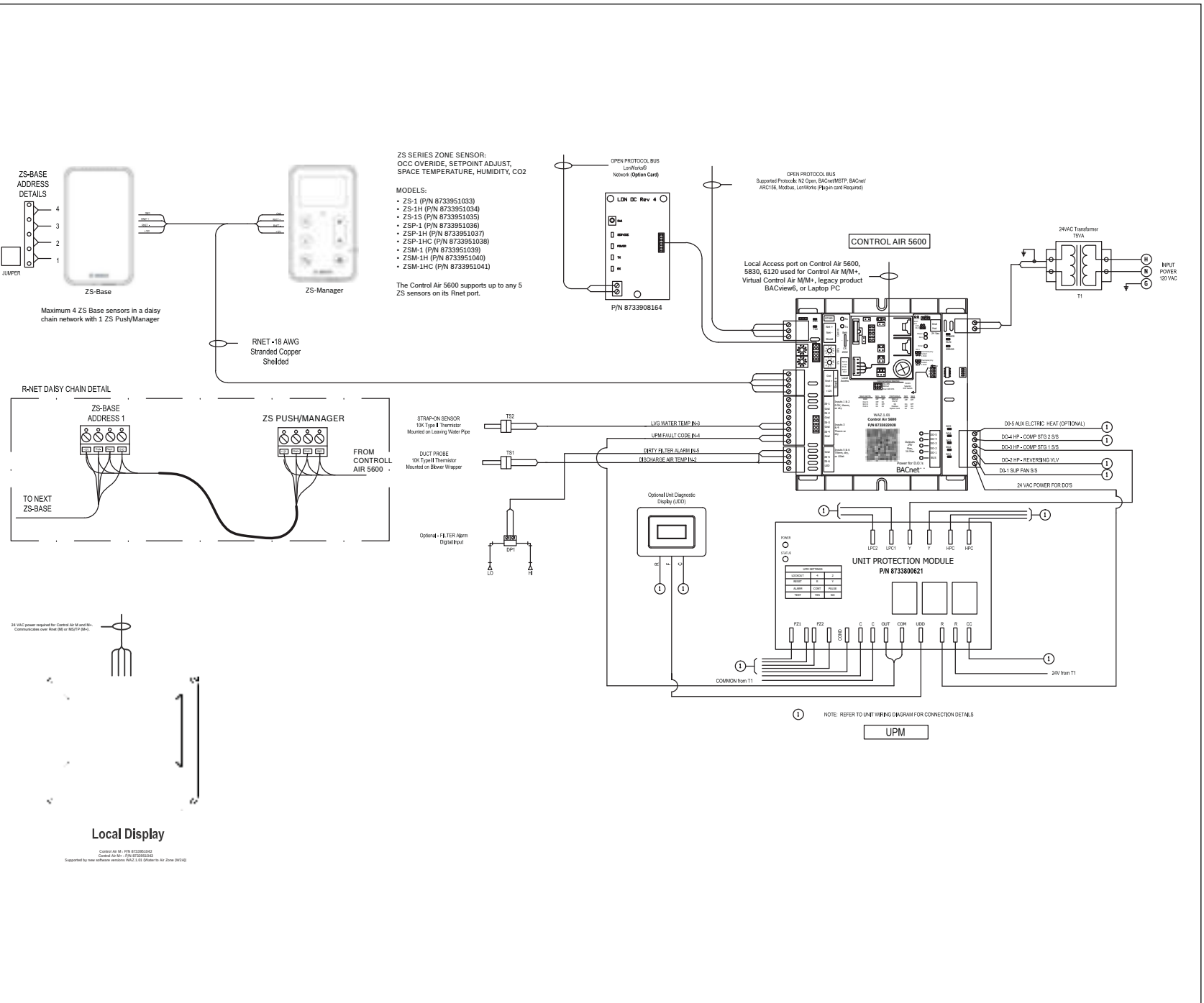

Figure 26

Data subject to change

02.2019 | BTC 469503102 B

11.2 Water to Water

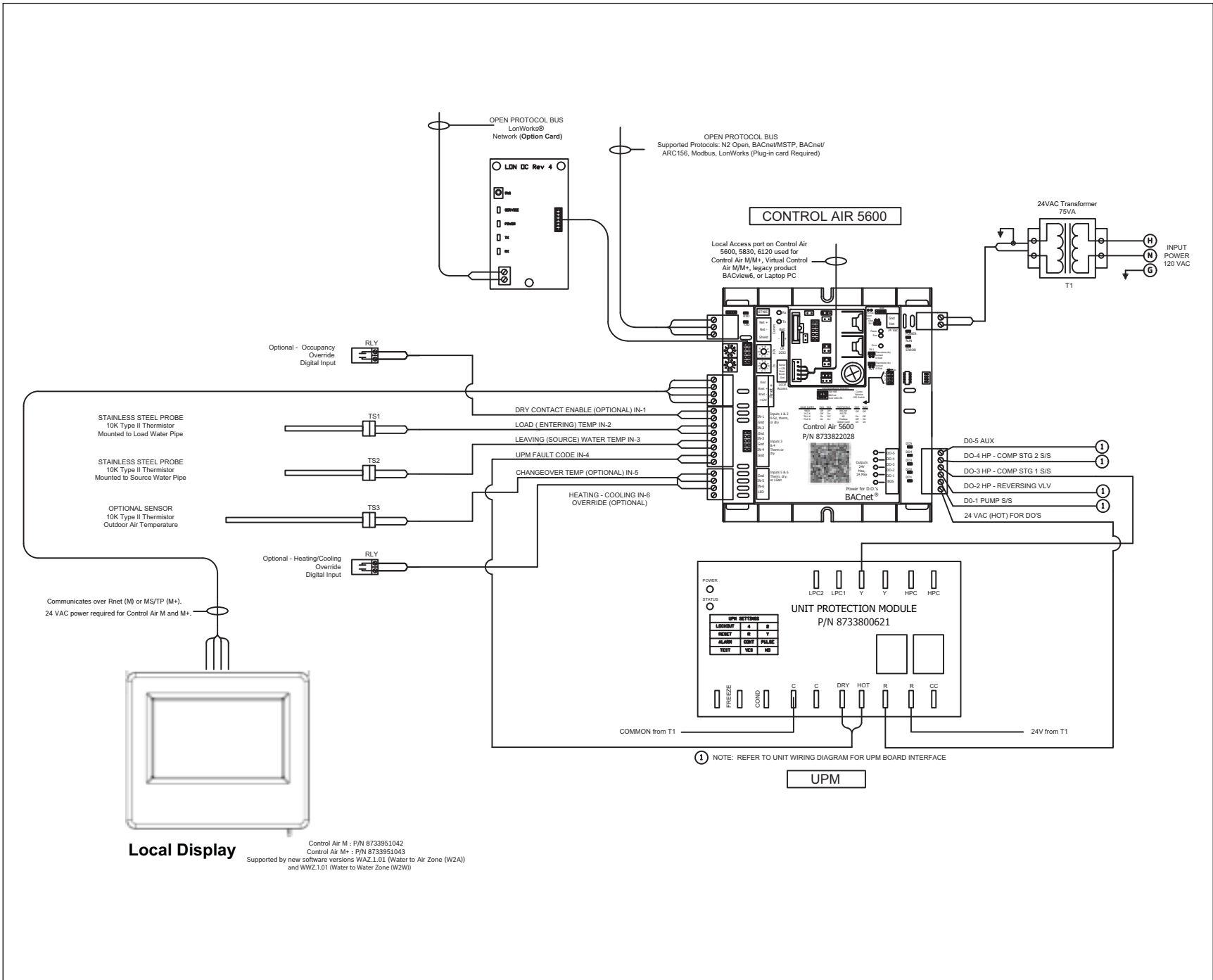

Figure 27

12 Terminology

PSC - Permanent-split capacitor motor

EER - Energy Efficiency Ratio

COP - Coefficient of Performance. The COP provides a measure of performance for heat pumps that is analogous to thermal efficiency for power cycles.

ECM -Electronically Commutated Motor.

UPM - Unit Protection Module

WLHP - Water Loop Heat Pump

GLHP - Ground Loop Heat Pump

RLA - Running Load Amps

LRA - Locked Rotor Amps

FLA - Full Load Amps

NPA - Name Plate Amps

HP – Heat Pump

Suction Pressure - Pressure entering compressor

Discharge Pressure - Pressure leaving compressor

(R/A) - Return Air

Recovery - Means the collection and storage of fluorinated greenhouse gases from products, including containers, and equipment during maintenance or servicing or prior to the disposal of the products or equipment;

Recycling - Means the reuse of a recovered fluorinated greenhouse gas following a basic cleaning process;

Reclamation - Means the reprocessing of a recovered fluorinated greenhouse gas in order to match the equivalent performance of a virgin substance, taking into account its intended use;

Decommissioning - Means the final shut-down and removal from operation or usage of a product or piece of equipment containing fluorinated greenhouse gases;

Repair - Means the restoration of damaged or leaking products or equipment that contain, or whose functioning relies upon, fluorinated greenhouse gases, involving a part containing or designed to contain such gases;

Conditioned space - Space within a building provided with heated or cooled air, or both (or surfaces); and, where required, with humidification or dehumidification means, to maintain conditions for an acceptable thermal environment.

13 Common Abbreviations

Abbreviation	Description
AFMS	Air Flow Measuring Station
AC	Air Conditioning
ACU	Air Conditioning Unit
AHU	Air Handling Unit
AI	Analog Input
AO	Analog Output
AUTO	Automatic
AUX	Auxiliary
BAS	Building Automation System
C	Common (24Vac)
CAM	Control Air Manager
CHW	Chilled Water
COND	Condenser
COMP	Compressor
CW	Condenser Water
CWP	Circulating Water Pump
DA	Discharge Air
DDC	Direct Digital Control
DES	Damper End Switch
DFS	Dirty Filter Switch
DI	Digital Input
DO	Digital Output
DPS	Differential Pressure Switch
DX	Direct Expansion
EA	Exhaust Air
EF	Exhaust Fan
EVAP	Evaporator
EW	Entering Water
F	Fahrenheit
FM	Flow Meter
FSS	Fan Status Switch
HGRH	Hot Gas Re-Heat
HP	Heat Pump
HW	Hot Water
IEM	Input Expansion Module
LP	Loop Pump
LW	Leaving Water
MA	Mixed Air
MAX	Maximum
MIN	Minimum
MINS	Minutes
MISC	Miscellaneous
MOD	Modulating
NC	Normally Closed

Abbreviation	Description
NO	Normally Open
OA	Outdoor Air
OAD	Outdoor Air Damper
OCC	Occupancy
R	Hot (24Vac)
RA	Return Air
RF	Return Fan
RH	Relative Humidity
RV	Reversing Valve
SA	Supply Air
SCR	Silicon Controlled Rectifier
SDP	Secondary Drain Pan
SDS	Smoke Detector Switch
SECS	Seconds
SF	Supply Fan
SOO	Sequence of Operation
SP	Static Pressure
S/S	Start/Stop
STG	Stage
TEMP	Temperature
UI	Universal Input
UPM	Unit Protection Module
VAV	Variable Air Volume
VES	Valve End Switch
VFD	Variable Frequency Drive
VLV	Valve
WSE	Water Side Economizer
WSHP	Water Source Heat Pump

Table 33

14 Thermostat Signals

Signal	Description
G	Fan Signal
O	Reversing Valve Signal
Y1	Compressor Stage 1 Signal
Y2	Compressor Stage 2 Signal
W	Electric Heat Signal
H	Reheat Signal
EV	Economizer Valve Signal
CV	Condenser Valve Signal
P	Pump Signal

Table 34

United States

Bosch Thermotechnology Corp.
65 Grove Street
Watertown, MA 02472

Tel: 866-642-3198
Fax: 603-965-7581
www.boschheatingandcooling.com