

2012-03-05

© 2012 Copyright TCO Development AB. All rights reserved.

TCO Certified Desktops 4.0



5 March 2012

Contents - TCO Certified Desktops

| | |
|--|-----------|
| SUPPORT (ON THIS DOCUMENT AND TCO CERTIFICATION) | 4 |
| INTRODUCTION | 5 |
| A CRITERIA | 6 |
| A.1 GENERAL INFORMATION | 6 |
| A.1.1 TCO CERTIFIED DOCUMENT..... | 7 |
| A.2 VISUAL ERGONOMICS | 8 |
| A.2.1 DISPLAY RESOLUTION REQUIREMENT..... | 8 |
| A.3 WORK LOAD ERGONOMICS | 9 |
| A.3.1 EASILY ACCESSIBLE CONNECTIONS..... | 9 |
| A.4 EMISSIONS | 10 |
| A.4.1 ALTERNATING ELECTRICAL FIELDS..... | 11 |
| A.4.2 ALTERNATING MAGNETIC FIELDS..... | 12 |
| A.4.3 ACOUSTIC NOISE..... | 13 |
| A.5 ELECTRICAL SAFETY | 15 |
| A.5.1 ELECTRICAL SAFETY..... | 15 |
| A.6 ENVIRONMENTAL REQUIREMENTS | 16 |
| A.6.1 PRODUCT DESCRIPTION..... | 17 |
| A.6.2 ORGANISATION..... | 19 |
| A.6.2.1 <i>Environmental management system certification</i> | 19 |
| A.6.3 CLIMATE..... | 21 |
| A.6.3.1 <i>Energy consumption</i> | 21 |
| A.6.3.2 <i>Energy consumption – external power supply</i> | 22 |
| A.6.4 ENVIRONMENTALLY HAZARDOUS SUBSTANCES..... | 23 |
| A.6.4.1 <i>Cadmium (Cd), mercury (Hg), lead (Pb) and hexavalent chromium (CrVI)</i> | 23 |
| A.6.4.2 <i>Halogenated substances</i> | 24 |
| A.6.4.3 <i>Non-halogenated substances</i> | 26 |
| A.6.4.4 <i>Plastics with chlorine and bromine as part of the polymer</i> | 28 |
| A.6.4.5 <i>Information regarding plastics, flame retarding agents and plasticizers</i> | 30 |
| A.6.5 PRODUCT LIFETIME..... | 32 |
| A.6.5.1 <i>Warranty and spare parts</i> | 32 |
| A.6.6 PREPARATION FOR RECYCLING..... | 33 |
| A.6.6.1 <i>Material coding of plastics</i> | 33 |
| A.6.6.2 <i>Variety of plastics</i> | 35 |
| A.6.6.3 <i>Moulded-in metal parts and metallization of plastic housing</i> | 37 |
| A.6.6.4 <i>Take back system</i> | 38 |
| A.6.7 PRODUCT PACKAGING..... | 40 |
| A.6.7.1 <i>Hazardous substances in product packaging</i> | 40 |
| A.6.7.2 <i>Preparation for recycling of product packaging material</i> | 41 |
| A.7 CORPORATE SOCIAL RESPONSIBILITY | 42 |
| A.7.1 CORPORATE SOCIAL RESPONSIBILITY..... | 42 |
| A.7.2 SENIOR MANAGEMENT REPRESENTATIVE..... | 44 |
| R REFERENCES | 45 |
| B TEST METHODS AND CLARIFICATIONS | 47 |
| B.0 GENERAL TEST CONDITIONS..... | 47 |
| B.0.1 <i>Definition of a test object</i> | 47 |
| B.0.2 <i>Required test object information</i> | 47 |
| B.0.3 <i>Conditions for the EUT</i> | 47 |

| | | |
|------------|---|-----------|
| B.0.4 | <i>Instruments used for testing</i> | 48 |
| B.0.5 | <i>Settings of the EUT</i> | 48 |
| B.0.6 | <i>Test report</i> | 49 |
| B.1 | GENERAL INFORMATION | 50 |
| B.1.1 | TCO CERTIFIED DOCUMENT..... | 50 |
| B.2 | VISUAL ERGONOMICS | 51 |
| B.2.1 | DISPLAY RESOLUTION REQUIREMENT | 51 |
| B.4 | EMISSIONS | 52 |
| B.4.0 | GENERAL TEST CONDITIONS FOR EMISSIONS | 52 |
| B.4.0.1 | <i>Basic test requirements</i> | 52 |
| B.4.0.2 | <i>Conditions and set up for the test object</i> | 52 |
| B.4.0.3 | <i>Emission measurement instruments</i> | 55 |
| B.4.1 | ALTERNATING ELECTRICAL FIELDS | 59 |
| B.4.2 | ALTERNATING MAGNETIC FIELDS | 62 |
| B.4.3 | ACOUSTIC NOISE | 64 |
| B.6 | ENVIRONMENTAL REQUIREMENTS | 65 |
| B.6.0 | GENERAL CLARIFICATION | 65 |
| B.6.0.1 | <i>Signatures</i> | 65 |
| B.6.1 | PRODUCT DESCRIPTION..... | 65 |
| B.6.2 | ORGANISATION..... | 65 |
| B.6.2.1 | <i>Environmental management system certification</i> | 65 |
| B.6.3 | CLIMATE..... | 66 |
| B.6.3.1 | <i>Energy consumption – Desktop computer</i> | 66 |
| B.6.3.2 | <i>Energy consumption – external power supply</i> | 66 |
| B.6.4 | ENVIRONMENTALLY HAZARDOUS SUBSTANCES..... | 67 |
| B.6.4.1 | <i>Cadmium (Cd), mercury (Hg), lead (Pb) and hexavalent chromium (CrVI)</i> | 67 |
| B.6.4.2 | <i>Halogenated substances</i> | 67 |
| B.6.4.3 | <i>Non-halogenated substances</i> | 68 |
| B.6.4.4 | <i>Plastics with chlorine and bromine as part of the polymer</i> | 68 |
| B.6.5 | PRODUCT LIFETIME | 69 |
| B.6.5.1 | <i>Warranty and spare parts</i> | 69 |
| B.6.6 | PREPARATION FOR RECYCLING..... | 69 |
| B.6.6.1 | <i>Material coding of plastics</i> | 69 |
| B.6.6.2 | <i>Variety of plastics</i> | 69 |
| B.6.6.3 | <i>Metallization of plastic housing and metal parts</i> | 69 |
| B.6.6.4 | <i>Take back system</i> | 70 |
| B.6.7 | PRODUCT PACKAGING..... | 70 |
| B.6.7.1 | <i>Hazardous substances in product packaging</i> | 70 |
| B.7 | CORPORATE SOCIAL RESPONSIBILITY | 71 |
| B.7.1.1 | <i>General Clarifications</i> | 71 |

Support (on this document and TCO Certification)

If you would like to certify your products and need support in understanding this document and the certification process, then TCO Development has partners that have laboratories around the world that can clarify this document and assist you with certification in your native language.

Please contact TCO Development for a list of partner laboratories:

certification@tcodevelopment.com

Or visit the TCO Development webpage for a list of partner laboratories:

www.tcodevelopment.com

Introduction

TCO Development has, since the end of the 1980s, influenced the development of IT equipment, particularly Visual Display Units (VDUs). Today, TCO Development's international certification system – TCO Certified – makes it easy to choose sustainably designed and produced IT and office equipment. It is a third party certification, Type 1 eco label according to ISO14024. The point of departure for this product group's criteria is the commitment to sustainability, whereby long term economic gains are dependent on social and environmental considerations. The criteria for TCO Certified include environmental and social aspects, and have been broadened from product focus to also include the production phase. This is a result of increased expectations around the world to respect human rights in the production and development of the products. The social responsibility criteria also cover quality aspects of the product, such as ergonomics, emissions and electrical safety. The criteria related to the environment include, for both product and production, aspects, such as energy consumption, content of hazardous materials, preparation for recycling and environmental management system at production sites.

With every major update of the criteria the aim is to extend and tighten the certification in order to keep in pace with technology innovation and development. All updates are a result of cooperation between key stakeholders, such as purchasers, users, producers, and researchers. This criteria document TCO Certified Desktops 4.0, is the fourth version of TCO Development's certification of computers. Going forward, subsequent versions, 4.1, 4.2 etc., might be released. However, these are to be considered only as updates within the sixth version with improved precision of the mandates and test methods.

It is permitted to quote from these criteria (e.g. in procurements), provided that the source is disclosed and the extent of the quotation is consistent with sound copyright practice. For further information, please visit www.tcodevelopment.com.

Stockholm, March 2012

TCO Development

Martin Söderberg

Business Area Manager Computers

A Criteria

A.1 General Information

This document contains requirements, test methods and references for Desktop computers. Desktop computers, such as desk-side computers and computers of tower type, are defined for the purposes of this document as follows:

A Desktop computer is a computer with the configuration that includes hardware such as: a mother board, a processor, a hard disc drive, memory boards, graphics card, CD/DVD-drive, a modem, a network card and a fan for cooling, all enclosed in one casing. A Desktop computer can communicate with the end user via a display that can be connected via analogue or digital I/O ports.

The aim of this criteria document is to provide relevant test methods and criteria for the actual use of the product. This criteria document has an A- and a B-part. The A-part includes the mandated criteria and the B-part clarifications and test methods.

Compliance to the mandates in this criteria document can be achieved in one of two ways. Those ways are either through a test report or through a verification report.

1. A test report is defined as a report based on:
 - Testing conducted by the laboratory issuing the test report on the product identified in the report.
2. A verification report is defined as a report based on:
 - A test report issued by a different laboratory.
 - Declarations from the Company applying for the certificate.

The alternatives accepted by TCO Development for each criterion can be found under each mandate respectively.

A.1.1 TCO Certified Document

Background

It is necessary that the purchaser of a product that has been certified in accordance with TCO Certified Desktops receives information concerning the quality, features and capabilities of the product. This information is based on the viewpoint from the user's perspective that TCO Development represents.

Applicability

All Desktop computers.

References

The contract between TCO Development and the Applicant/Brand owner.

Mandate A.1.1:

A TCO Certified Document written in English or the native language where the product is to be sold shall accompany the product. The document shall describe why these particular requirements have been chosen for the products within the program of TCO Certified Notebooks and what is expected to be achieved by them. The document may be provided as an electronic file. An English version of the text can be obtained from TCO Development.

Examples of how the document can accompany the product are presented below:

- A separate printed document.
- As an electronic file or in the user's manual.
- At the manufacturers web site, together with information about the product. A reference to the web site shall accompany the product.

The following information shall be submitted to the verifier at the test laboratory:

A written guarantee that the above mandate is fulfilled. The document shall be signed by the responsible person at the applicant company.

The following information shall be submitted with the application to TCO Development:

A copy of a verification report from a test laboratory approved by TCO Development.

We hereby guarantee that the above mandate is fulfilled.

.....
Product brand name and model/type

.....
Signature

.....
Name and title in block capitals

.....
Date

.....
Company

A.2 Visual ergonomics

Today computers displays are an essential tool for users in all kinds of environments. Good visual ergonomics is a very important aspect of quality that can also have a direct effect on the health, comfort and performance of the user.

In the increasing tide of the Display market becoming dominated by FPD (Flat panel displays) in the office with wide screen and high resolution technique, it is important not to forget that the CRT type displays are still in use in many parts of the world for economic and performance reasons. Therefore it is very important that the computer can achieve both frequencies used in these different types and also display a low resolution for smaller display use.

A.2.1 Display resolution requirement

Background

This requirement is to ensure that the Desktop computer can provide a picture on a display at the required frequency and also a minimal display resolution.

Applicability

All Desktop computers.

Test procedure

See B.2.0.

Reference

1.

Mandate A.2.1:

1. The computer shall be equipped with a digital output.
2. The computer shall be able to display a picture at both 85 Hz and 60 Hz with a resolution of at least 1024 x 768.

The following information shall be submitted with the application to TCO Development:

A copy of a verification report from a test laboratory approved by TCO Development.

A.3 Work load ergonomics

Work load ergonomics refers to the adaptation of the task, tools, work place and physical environment where the product will be used. These requirements are in place in order to meet and optimize the users' needs for a good work environment.

A.3.1 Easily accessible connections

Background

It should be easy to connect common external devices, such as a USB memory stick. A digital connection on the Desktop computer guarantees a high quality signal to the display which enhances the visual ergonomics of the display

Applicability

All Desktop computers.

References

2.

Mandate A.3.1:

At least one USB connection or similar interface socket shall be located on the front side of the Desktop computer.

The following information shall be submitted with the application to TCO Development:

A copy of a verification report from a test laboratory approved by TCO Development.

A.4 Emissions

Users of IT equipment increasingly have several nearby electrical and magnetic field sources placed on work surfaces that they are exposed to. The permanent relationship of the body to certain field sources, such as visual distance from displays, mobile telephone location next to the ear and the proximity of task-specific lighting are realities that exacerbate the situation.

When the first TCO Development label was introduced in 1992 for displays one of the main interests was the requirements for electrical and magnetic fields. To this day scientists and experts are divided on the question if these fields pose health risks to humans.

Due to continued public concern and the increasing amount of emissions surrounding us, TCO Development remains convinced that the criteria in our documents are still highly relevant, even with today's slim lined products. TCO Certified emission criteria are created to make certain that internal shielding is used to ensure that a TCO Certified product's emissions are at a technically achievable low level and will not raise normal background levels when the product is used in a working environment.

TCO Certified criteria cover emissions around the product since it may be placed where persons, other than the user, are working in close proximity.

A.4.1 Alternating electrical fields

Background

Alternating electrical fields are created between objects that have different levels of electrical potential which change over time. When the potential changes in a periodic manner, an alternating electrical field is set up with a field strength and a frequency. A Desktop computer contains many sources of alternating electrical fields. The field characteristics depend on the actual electrical potential difference and the distance from the Desktop computer.

IT users are often concerned about a possible health risk arising from alternating electrical fields generated by equipment. Quite a large number of users also report various kinds of symptoms that cannot completely be attributed to the influence of other factors in their environment or to medical reasons.

The mandatory requirements are based on the ambition to reduce the alternating electrical fields to such a low level as not to burden the work and home environment with unnecessary factors. The mandatory requirements shall not be regarded as hygienic limit values.

Applicability

All Desktop computers.

Test procedure

See B.4.1.

Mandate A.4.1:**Band I: 5 Hz to 2 kHz, ≤ 10 V/m**

Measured at 0.50 m in front of the Desktop computer.

Band II: 2 kHz to 400 kHz, ≤ 1.0 V/m

Measured at 0.50 m around the Desktop computer.

The following information shall be submitted with the application to TCO Development:

A copy of a test report from a test laboratory approved by TCO Development.

A.4.2 Alternating magnetic fields

Background

Alternating magnetic fields are created when an alternating electrical current flows through a conductor. Like other electrical equipment, Desktop computers are surrounded by alternating magnetic fields. These alternating magnetic fields are generated by different parts of the product, e.g. power supply unit, voltage inverters and other electrical circuits. The field strength depends on the actual electric current and on the distance from the Desktop computer.

IT users are often concerned about a possible health risk arising from alternating magnetic fields generated by equipment. Quite a large number of users also report various kinds of symptoms that cannot completely be attributed to the influence of other factors in their environment or to medical reasons.

The mandatory requirements are based on the ambition to reduce the alternating magnetic fields to such a low level as not to burden the work and home environment with unnecessary factors. The obligatory requirements shall not be regarded as hygienic limit values.

Applicability

All Desktop computers.

Test procedure

See B.4.2.

Mandate A.4.2:**Band I: 5 Hz to 2 kHz, ≤ 200 nT**

Measured at 0.50 m around the Desktop computer.

Band II: 2 kHz to 400 kHz, ≤ 25 nT

Measured at 0.50 m around the Desktop computer.

The following information shall be submitted with the application to TCO Development:

A copy of a test report from a test laboratory approved by TCO Development.

A.4.3 Acoustic noise

Background

Acoustic noise from fans, hard disk drives, etc. can be annoying. To prevent such annoyance, the aim shall be that Desktop computers shall cause a minimum of noise during usage. Many end users are sensitive to noise with different characteristics. To give the end-user a possibility to choose a product with a comfortable noise level and frequency characteristics generated by a product, this information should be declared, together with all other data related to a certain product.

Definitions

To be able to provide information about acoustic noise levels that permits comparison between different Desktop computers the declared A-weighted sound power level (L_{WA_d}) in operating and idling mode measured in accordance with ISO 9296 shall be reported. The following definitions apply:

Sound power level (L_W):

Total emitted sound power from a sound source, given in bels (B) and with the reference 1 pW .

A-weighting:

The measured linear sound level (sound pressure or sound power) weighted against the sensitivity of the human ear for different frequencies (A-curve).

Declared A-weighted sound power level (L_{WA_d}): in bels (B). Defined in accordance with ISO 9296 3.2.5.

Operating mode. A condition in which the system and hard disk drive shall be operated in accordance with ECMA-74 C.15.3.2 and C.9.3.2.

Idling mode. A condition in which the system shall be operated in accordance with ECMA-74 C.15.3.1.

Applicability

All Desktop computers with integrated moving parts.

Test procedure

See B 4.3 and ISO 7779:2010

References

3-9

Mandate A.4.3:

For Desktop computers with integrated moving parts, such as motor driven hdd, fans, etc.

1. The *declared A-weighted sound power level (LWAd)* shall not exceed:

Operating mode: 4.4B

Idling mode: 3.9B

If the product does not emit prominent discrete tones according to procedures specified in ECMA 74 Annex D a higher declared A-weighted sound power level (LWAd) is accepted but shall not exceed:

Operating mode: 4.7B

Idling mode: 4.2B

2. The A-weighted sound power level for a product shall be declared in the product data sheet and/or in any other product descriptions.

The following information shall be submitted with the application to TCO Development:

A copy of a test report from a test laboratory approved by TCO Development.

A.5 Electrical safety

A.5.1 Electrical safety

Background

Electrical safety concerns the electrical design of apparatus with respect to its electrical insulation and other arrangements that are intended to prevent accidents resulting from contact with live components, and the risk of fire or explosion as a result of electrical flash-over due to inadequate or faulty electrical insulation.

Applicability

All Desktop computers with built-in power supplies as well as any separate power supply intended to be used together with the Desktop computer.

References

10.

Mandate A.5.1:

The Desktop computer and the internal or external power supply/supplies shall be certified in accordance with EN/IEC 60 950 or EN/IEC 60 065.

The following information shall be submitted with the application to TCO Development:

A copy of the CB certificate or national certificate from a CB member (NCB).

A.6 Environmental requirements

The TCO Certified label requirements combine a unique integrated balance of indoor and outdoor environmental issues. Achieving a good working environment should not be at the expense of the natural environment. This document details the environmental requirements of the TCO Certified label.

The Environmental requirements are divided into the following sections:

1. Organisation – requirements focusing on the production phase, and environmental management.
2. Climate – energy consumption, one of the most important issues in the environmental impact of IT products.
3. Hazardous Substances – heavy metals, flame retardants, plastics.
4. Product Lifetime – factors to extend the life of the product.
5. Preparation for Recycling – factors to stimulate recycling.
6. Packaging – hazardous substance content and recycling.

Potential environmental effects are evident at each stage of the product life cycle. Due to the complexity of the production of ICT products, it is often most effective to refer to indirect requirements on the production such as requirements for an environmental management system. Should a more direct quality-assured system for manufacturing processes become possible, TCO Development would consider that option for future requirements. The environmental requirements TCO Development has focused on in this standard are those that we consider most relevant to the product group. They have also proved to be attainable in volume production and are verifiable. Future updates of the standard will likely focus on hazardous substances, social responsibility and climate issues.

All requirements except section **A.6.3 Climate** shall be verified by sending the requested information to a verifier at a test laboratory approved by TCO Development. The energy consumption requirements in section A.6.3 shall be tested at a test laboratory approved by TCO Development.

A.6.1 Product description

Background

The aim of this product description is to provide information about the product that is to be reviewed for compliance with the environmentally related requirements of Section A.6 and also for information collection.

Definitions

Marking plate/Marking label is the label that contains the product's electrical rating in terms of voltage, frequency, current and the manufacturer's name, trademark or identification mark together with the manufacturer's model or type reference. The label shall be in accordance with IEC 60 950:1 clause 1.7.1.

Applicability

All Desktop computers.

Clarification

B.6.1

References

10

Mandate A.6.1:

A product declaration shall be provided for the Desktop computer.

The following information shall be submitted to an approved verifier:

1. The declaration below, completed where applicable.
2. A copy of the marking label for the Desktop computer and any external power supply.

The information submitted shall be signed by the responsible person at the applicant company.

The following information shall be submitted with the application to TCO Development:

A copy of a verification report from a verifier at a laboratory approved by TCO Development and a copy of the marking label.

Desktop computer declaration

| Desktop computer | Information |
|-------------------------|--------------------|
| Manufacturer | |
| Brand name | |
| Brand Owner | |
| Type/Model name | |
| Product Family name | |

| External Power supply: Brand & model name | Rating and class |
|--|-------------------------|
| | |
| | |
| | |

TCO Certified Certificate holder

We hereby guarantee that the above mandate is fulfilled.

.....
Product brand name and model name

.....
Signature

.....
Name and title in block capitals

.....
Date

.....
Company

A.6.2 Organisation

A.6.2.1 Environmental management system certification

Background

A certified environmental management system is proof that the company shows concern for the environment and has chosen to work in a systematic way with constant improvement of the environmental performance of the company and its products in focus. A certified environmental management system includes external independent reviews.

Definitions

Manufacturing plant: Production facility where the final assembly of the TCO certified product is taking place.

Applicability

The company or companies which manufacture the Desktop computer.

Clarification

B.6.2.1

References

11, 12.

Mandate A.6.2.1:

Each *manufacturing plant* must be certified in accordance with ISO 14001, or EMAS registered. If the product is manufactured by a third party, it is this company that shall be certified or registered.

If the *manufacturing plant* does not have an ISO 14001 certificate or EMAS registration at the time of application, the *manufacturing plant* is given a 12-month grace period to obtain ISO14001 certification or EMAS registration.

The following information shall be submitted to an approved verifier:

1. A document showing the names and addresses of the manufacturing plants.
2. Copy of the ISO 14001 certificate or EMAS registration or, when not available, an estimated date of certification/registration.
3. A written guarantee that the certificate/registration is valid and that the mandate above is fulfilled, signed by the responsible person at the applicant company.

The following information shall be submitted with the application to TCO Development:

A copy of a verification report from a verifier approved by TCO Development.

We hereby guarantee that the above mandate is fulfilled.

.....
Product brand name and model name

.....
Signature

.....
Name and title in block capitals

.....
Date

.....
Company

A.6.3 Climate

A.6.3.1 Energy consumption

Background

Energy is the single most important topic in the issue of climate change. Energy efficient equipment is an important and effective way to fight climate change. With an ever-increasing volume of IT equipment in use, the efficiency of each product is vital.

This requirement and test method is based on the most recently published Energy Star standard for computers.

Definitions

The energy consumption requirement in accordance with the most recently published Energy Star® standard for computers.

Applicability

All Desktop computers.

Test procedure

B.6.3.1

References

17

Mandate A.6.3.1:

The energy consumption requirements in the most recently published Energy Star® standard for computers on the date of application shall be fulfilled and verified through testing by a test laboratory approved by TCO Development.

The following information shall be submitted with the application to TCO Development:

A copy of a test report from a test laboratory approved by TCO Development.

A.6.3.2 Energy consumption – external power supply

Background

Energy is the single most important topic in the issue of climate change. Energy efficient equipment is an important and effective way to fight climate change. With an ever-increasing volume of IT equipment in use, the efficiency of each product is vital. To reduce energy consumption from the product the external power supply shall comply with the International Efficiency Marking Protocol for External Power Supplies.

Applicability

All external power supplies.

Clarification

B.6.3.2

References

18

Mandate A.6.3.2:

The external power supply shall meet at least the International Efficiency Protocol requirement for level V

The following information shall be submitted to the verifier at the test laboratory:

A copy of the marking label for the external power supply

The following information shall be submitted with the application to TCO Development:

A copy of the marking label for the external power supply

A.6.4 Environmentally hazardous substances

A.6.4.1 Cadmium (Cd), mercury (Hg), lead (Pb) and hexavalent chromium (CrVI)

Background

The effects of the listed substances are well documented as environmental hazardous substances. EU regulated these substances in the RoHS directive (2002/95/EC) and continues to do so in the RoHS2 Directive (2011/65/EU).

Applicability

All Desktop computers.

Clarification

B.6.4.1

References

19, 20 and 21.

Mandate A.6.4.1:

The Desktop computer shall not contain cadmium, mercury, lead and hexavalent chromium.

Note: The requirement applies to components, parts, and raw materials in all assemblies and sub-assemblies of the product e.g. paint, surface treatment, plastics and electronic components.

The following information shall be submitted to an approved verifier:

A written guarantee that the above mandate is fulfilled. The guarantee shall be signed by the responsible person at the applicant company.

The following information shall be submitted with the application to TCO Development:

A copy of a verification report from a verifier approved by TCO Development.

We hereby guarantee that the above mandate is fulfilled.

.....
Product brand name and model name

.....
Signature

.....
Name and title in block capitals

.....
Date

.....
Company

A.6.4.2 Halogenated substances

Background

Brominated and chlorinated flame retardants and other halogenated substances are often persistent, can bioaccumulate in living organisms and have been detected in flora and fauna.

A series of international elimination activities in respect to brominated and chlorinated flame retardants is currently in progress within several national and international bodies, e.g. EU, OECD and North Sea Conference.

Definitions

Plastic parts are parts made mainly of plastics, e.g. the housing. Parts containing other materials in any significant amounts, e.g. cables with metal conductors, are not included in the definition.

Printed wiring board laminate is a printed board that provides point-to-point connections but not printed components in a predetermined configuration on a common base.

Applicability

All Desktop computers.

Clarification

B.6.4.2

References

22.

Mandate A.6.4.2:

1. *Plastic parts* weighing more than 25 grams shall not contain flame retardants or plasticizers that contain organically bound bromine or chlorine.

Note: The requirement applies to plastic parts in all assemblies and sub-assemblies. Exempted are *printed wiring board laminates*, electronic components and all kinds of cable insulation.

2. The Desktop computer shall not contain PBB, PBDE and HBCDD.

Note: The requirements apply to components, parts and raw materials in all assemblies and sub-assemblies of the product e.g. batteries, paint, surface treatment, plastics and electronic components.

The following information shall be submitted to an approved verifier:

A written guarantee that the above mandate is fulfilled. The guarantee shall be signed by the responsible person at the applicant company.

The following information shall be submitted with the application to TCO Development:

A copy of a verification report from a verifier approved by TCO Development.

We hereby guarantee that the above mandate is fulfilled.

.....
Product brand name and model name

.....
Signature

.....
Name and title in block capitals

.....
Date

.....
Company

A.6.4.3 Non-halogenated substances

Background

The purpose of this mandate is to ensure that the phase out of halogenated flame retardants avoids a shift towards substances with other known hazardous effects.

The mandate focuses on 14 hazardous statements. All substances relevant for the IT industry that have been assigned a hazardous statement and where there are less hazardous commercially available alternatives will be restricted from TCO Certified products. The list of these substances is evaluated and revised in each new version of the criteria document.

To date in this version, only harmonized substances found on the European chemical Substance Information System (ESIS) at: <http://esis.jrc.ec.europa.eu/> have been restricted. In the future version of the criteria document TCO Development have the ambition to also restrict substances that are not at this time harmonized. An example of such not yet harmonized substances may be found in B.6.4.3.

Definitions

Plastic parts are parts made mainly of plastics, e.g. the housing. Parts containing other materials in any significant amounts, e.g. cables with metal conductors, are not included in the definition.

Printed wiring board laminate is a printed board that provides point-to-point connections but not printed components in a predetermined configuration on a common base.

Hazardous statements (Risk phrases) according to EU Regulation 1272/2008 (EU Directive 67/548/EEC)

- H340 (R46) (may cause heritable genetic damage)
- H341 (R68) (suspected of causing genetic defects)
- H350 (R45) (may cause cancer)
- H350i (R49) (may cause cancer by inhalation)
- H351 (R40) (limited evidence of a carcinogenic effect)
- H360F (R60) (may impair fertility)
- H360D (R61) (may cause harm to the unborn child)
- H361d (R63) (suspected of damaging the unborn child)
- H361f (R62) (suspected of damaging fertility)
- H362 (R64) (may cause harm to breast-fed children)
- H372 (R48/25/24/23) (danger of serious damage by prolonged exposure)
- H373 (R48/20/21/22) (may cause damage to organs through prolonged exposure)
- H400 and H410 (R50/R53) (very toxic to aquatic organisms / may cause long-term adverse effects in the aquatic environment)
- H411 (R51/53) (Toxic to aquatic life with long-lasting effects)

Applicability

All Desktop computers.

Clarification

B.6.4.3

References

23 and 24.

Mandate A.6.4.3:

The following non halogenated flame retardants shall not be used in plastic parts that weigh more than 25 grams since they are *harmonized* and covered by one or more of the hazardous statements restricted for TCO Certified products:

- Antimony(III) oxide (Sb2O3), CAS: 1309-64-4
- Tri-o-cresyl phosphate, CAS: 78-30-8

Exempted are *printed wiring board laminates*, electronic components and all kinds of cable insulation.

The following information shall be submitted to an approved verifier:

A written guarantee that the above mandate is fulfilled. The guarantee shall be signed by the responsible person at the applicant company.

The following information shall be submitted with the application to TCO Development:

A copy of a verification report from a verifier approved by TCO Development.

We hereby guarantee that the above mandate is fulfilled.

.....
Product brand name and model name

.....
Signature

.....
Name and title in block capitals

.....
Date

.....
Company

A.6.4.4 Plastics with chlorine and bromine as part of the polymer

Background

PVC is by far the most common halogen containing plastic. There are however other plastics that contain chlorine or bromine in the plastic itself. As the requirement concerning permissible flame retardants tightens, the risk increases that halogenated plastics will become more common. TCO Development sees a future environmental risk with such a development.

PVC is a much-debated plastic that can pose environmental problems in most parts of its life cycle. The magnitude of the environmental problems relating to PVC differs depending on the environmental status of a particular manufacturing facility and the uses of additives. At present there are very limited possibilities to distinguish between harmful and less harmful production facilities for PVC.

Definitions

Plastic parts are parts made mainly of plastics, e.g. the housing. Parts containing other materials in any significant amounts, e.g. cables with metal conductors, are not included in the definition.

Printed wiring board laminate is a printed board that provides point-to-point connections but not printed components in a predetermined configuration on a common base.

Applicability

All Desktop computers.

Clarification

B.6.4.4

References

20 and 25.

Mandate A.6.4.4:

Plastic parts in the Desktop computer weighing more than 25 grams shall not contain chlorine or bromine as a part of the polymer.

Note that *printed wiring board laminates*, and all kinds of internal and external cable insulation are not considered to be part of *plastic parts* and are therefore not included in the mandate.

The following information shall be submitted to an approved verifier:

A written guarantee that the above mandate is fulfilled. The guarantee shall be signed by the responsible person at the applicant company.

The following information shall be submitted with the application to TCO Development:

A copy of a verification report from a verifier approved by TCO Development.

We hereby guarantee that the above mandate is fulfilled.

.....
Product brand name and model name

.....
Signature

.....
Name and title in block capitals

.....
Date

.....
Company

A.6.4.5 Information regarding plastics, flame retarding agents and plasticizers

Background

This requirement is intended to give information about the plastics and flame retarding agents in the product to be reviewed for compliance with the environment requirements in this criteria document.

Definitions

Plastic parts are parts made mainly of plastics, e.g. the housing. Parts containing other materials in any significant amounts, e.g. cables with metal conductors, are not included in the definition.

Printed wiring board laminate is a printed board that provides point-to-point connections but not printed components in a predetermined configuration on a common base.

Applicability

All Desktop computers.

References

22, 26, 27 and 28.

Mandate A.6.4.5:

The material specifications shall be provided for *plastic parts* and *printed wiring board laminates* weighing more than 25 grams. Plasticizers or flame retardants that have concentrations above 1% by weight in the plastic part shall be stated, in accordance with ISO 1043-3 or ISO 1043-4.

The following information shall be submitted to an approved verifier:

The table below shall be completed and the guarantee signed by the responsible person at the applicant company.

Manufacturers of plastic materials who consider such information confidential may submit the information to a verifier approved by TCO Development.

The following information shall be submitted with the application to TCO Development:

A copy of a verification report from a verifier approved by TCO Development.

| Plastic part and PWB name | Weight in grams | Type of plastic | Plastic manufacturer name | Plastic model name | Flame retardant/ plasticizer type | Flame retardant/plasticizer CAS number*) | Plastic label code **) |
|---------------------------|-----------------|-----------------|---------------------------|--------------------|-----------------------------------|--|------------------------|
| | | | | | | | |
| | | | | | | | |
| | | | | | | | |
| | | | | | | | |

*) Chemical Abstract Service number www.cas.org

**) Labelling according to ISO 11469

We hereby guarantee that the above mandate is fulfilled.

.....
Product brand name and model name

.....
Signature

.....
Name and title in block capitals

.....
Date

.....
Company

A.6.5 Product lifetime

A.6.5.1 Warranty and spare parts

Background

A longer product lifetime has a significant positive contribution to resource use as well as the reduction of air and water pollution. A pre-condition for prolonged lifetime is that the product is of high quality, which is supported by good guarantees. Another requirement is the availability of spare parts for the product once it is taken out of production.

Definitions

Brand owner: The company or organization owning or controlling the *Brand Name*.
Brand Name: The name or sign, including but not limited to a trademark or company name, used to identify, amongst users and customers, the manufacturer or seller of a product.

Product Warranty is a period where the brand owner offers to repair or replace broken products during a period of time without charge

Spare parts are those parts which have the potential to fail during the normal use of the product. Product parts whose life cycle usually exceeds the average usual life of the product need not be provisioned as spare parts.

Applicability

All Desktop computers.

Clarification

B.6.5.1

Mandate A.6.5.1:

The *brand owner* shall provide a *product warranty* for a period of at least one year.

The *brand owner* shall guarantee the availability of *spare parts* for at least three years from the time that production ceases.

The following information shall be submitted to an approved verifier:

A written guarantee that the above mandate is fulfilled. The guarantee shall be signed by the responsible person at the *brand owner* company.

The following information shall be submitted with the application to TCO Development:

A copy of a verification report from a verifier approved by TCO Development.

We hereby guarantee that the above mandate is fulfilled.

| | |
|--|---|
| Product brand name | Model name(s) or "All products" |
| Signature | Name and title in block capitals |
| Date (Declaration valid 1 year from date) | Brand Owner Company |

A.6.6 Preparation for Recycling

A.6.6.1 Material coding of plastics

Background

Recycling of used electronic products is an important environmental issue. Material recycling and reuse are the best options from an environmental point of view. With material coding there is a better possibility for plastics to be recycled and used in new IT equipment.

Definitions

Plastic parts are parts made mainly of plastics, e.g. the housing. Parts containing other materials in any significant amounts, e.g. cables with metal conductors, are not included in the definition.

Printed wiring board laminate is a printed board that provides point-to-point connections but not printed components in a predetermined configuration on a common base.

Applicability

All Desktop computers.

Clarification

B.6.6.1

References

23, 28 and 29.

Mandate B.6.6.1:

Plastic parts weighing more than 25 grams shall be material coded in accordance with ISO 11469 and ISO 1043-1, -2, -3, -4. Such parts shall be listed in the table at Section A.6.4.5.

Exempted are *printed wiring board laminates*.

The following information shall be submitted to an approved verifier:

A written guarantee that the above mandate is fulfilled. The guarantee shall be signed by the responsible person at the applicant company.

The following information shall be submitted with the application to TCO Development:

A copy of a verification report from a verifier approved by TCO Development.

We hereby guarantee that the above mandate is fulfilled.

.....
Product brand name and model name

.....
Signature

.....
Name and title in block capitals

.....
Date

.....
Company

A 6.6.2 Variety of plastics

Background

Recycling of used electronic products is an important environmental issue. Material recycling and reuse are the best options from an environmental point of view. Therefore TCO Development presents requirements that facilitate material recycling.

Applicability

All Desktop computers.

Clarification

B.6.6.2

Definitions

Types of *plastic material* (using the abbreviation terms, symbols and concepts for plastics in ISO 1043 Part 1, 2, 3, and 4) are:

- Basic polymers
- Mixtures of polymers
- Basic polymers with flame retardants
- Mixtures of polymers with flame retardants

References

28 and 29.

Mandate A.6.6.2:

No more than two different types of *plastic materials* are accepted for parts weighing more than 100 grams.

The following information shall be submitted to an approved verifier:

A written guarantee that the above mandate is fulfilled. The guarantee shall be signed by a responsible person at the applicant company.

The following information shall be submitted with the application to TCO Development:

A copy of a verification report from a verifier approved by TCO Development.

We hereby guarantee that the above mandate is fulfilled.

.....
Product brand name and model name

.....
Signature

.....
Name and title in block capitals

.....
Date

.....
Company

A.6.6.3 Moulded-in metal parts and metallization of plastic housing

Background

Recycling of used electronic products is an important environmental issue. Material recycling and reuse are the best options from an environmental point of view. Therefore TCO Development presents requirements that facilitate material recycling.

Definition

Metallization is a surface deposition process whereby a metallic layer is applied to the surface of a completed shaped plastic part. Examples of metallization processes are chemical coating and ion vapour deposition.

In-Mould Insert Moulding is the process by which a metal insert is incorporated into the plastic during the moulding stage, making it extremely difficult to separate the metal from the plastic by using standard tools.

Applicability

All Desktop computers.

Clarification

B.6.6.3

Mandate A.6.6.3:

1. There shall be no internal or external *metallization* of the Desktop computer outer plastic casing.
2. In-Mould Insert Moulding or glued metal parts are not accepted.

The following information shall be submitted to an approved verifier:

A written guarantee that the above mandate is fulfilled. The guarantee shall be signed by the responsible person at the applicant company.

The following information shall be submitted with the application to TCO Development:

A copy of a verification report from a verifier approved by TCO Development.

We hereby guarantee that the above mandate is fulfilled.

.....
Product brand name and model name

.....
Signature

.....
Name and title in block capitals

.....
Date

.....
Company

A.6.6.4 Take back system

Background

The amount of electronic waste in the world today is enormous and a growing environmental problem. It is important that manufacturers provide mechanisms to take back their equipment at end-of-life under the principle of individual producer responsibility wherein each producer must be financially responsible for managing its own brand products at end-of-life. Currently much electronic waste is being exported to developing countries where it is managed unsustainably and disproportionately burdens developing countries with this global environmental burden. The Basel Convention and its decisions govern the export of many types of electronic waste. However not all countries have properly implemented these decisions. With this mandate TCO Development aims to put more influence into spreading better electronic waste management practice to more countries.

Definition

Brand owner: The company or organization owning or controlling the Brand Name.

Brand Name: The name or sign, including but not limited to a trademark or company name, used to identify, amongst users and customers, the manufacturer or seller of a product.

Take back system is a system that makes sure that the customer can return used products to be recycled. The system can be with or without a fee.

Environmentally acceptable recycling methods are:

- Product and component reuse
- Material recycling with secured handling of hazardous chemicals and heavy metals
- Pollution-controlled energy recovery of parts of the product

Applicability

All Desktop computers.

Clarification

B.6.6.4

References

30.

Mandate A.6.6.4:
 The *brand owner* (or its representative, associated company or affiliate) shall offer their customers the option to return used products for *environmentally acceptable recycling methods* in at least one market where the product is sold and where electronics take back regulation is not in practice at the date of application.

The following information shall be submitted to an approved verifier:
 The information stated in the list below shall be submitted and the guarantee signed by the responsible person at the *brand owner* company.

The following information shall be submitted with the application to TCO Development:
 A copy of a verification report from a verifier approved by TCO Development.

The requirement can be fulfilled by one of three options (to be verified):

- 1. Product only sold on markets with WEEE legislation or similar
 - 2. World-wide product take back*
 - 3. One additional market lacking WEEE legislation where product take back is offered*
- Name of market.....

*The brand owner shall also submit a short description, to an approved verifier, of the take back system or reference to the representative, associated company or affiliate taking care of the take-back system

We hereby guarantee that the above mandate is fulfilled.

| | |
|--|---|
| Product brand name | Model name(s) or "All products" |
| Signature | Name and title in block capitals |
| Date (Declaration valid 1 year from date) | Brand Owner Company |

A.6.7 Product packaging

A.6.7.1 Hazardous substances in product packaging

Background

Packaging constitutes a well-known environmental problem and is regulated in many countries worldwide. Packaging material has a short lifetime and generates large volumes of waste.

There are three main areas of concern, content of hazardous substances, use of resources and transport volume.

Applicability

All packaging material.

Definition

Brand owner: The company or organization owning or controlling the Brand Name.

Brand Name: The name or sign, including but not limited to a trademark or company name, used to identify, amongst users and customers, the manufacturer or seller of a product.

Clarification

B.6.7.1

References

31.

Mandate A.6.7.1:

The packaging material shall not contain lead (Pb), cadmium (Cd), mercury (Hg) or hexavalent chromium (Cr6).

Plastic packaging material shall not contain organically bound halogens.

The following information shall be submitted to an approved verifier:

A written guarantee that the mandate above is fulfilled. The guarantee shall be signed by the responsible person at the *brand owner* company.

The following information shall be submitted with the application to TCO Development:

A copy of a verification report from a verifier approved by TCO Development.

We hereby guarantee that the above mandate is fulfilled.

.....
Product brand name

.....
Model name(s) or "All products"

.....
Signature

.....
Name and title in block capitals

.....
Date (Declaration valid 1 year from date)

.....
Brand Owner Company

A.6.7.2 Preparation for recycling of product packaging material

Background

Packaging constitutes a well-known environmental problem and is regulated in many countries worldwide. Packaging material has a short lifetime and generates large volumes of waste.

There are three main areas of concern, content of hazardous substances, use of resources and transport volume.

Applicability

All packaging material.

Definition

Brand owner: The company or organization owning or controlling the Brand Name.

Brand Name: The name or sign, including but not limited to a trademark or company name, used to identify, amongst users and customers, the manufacturer or seller of a product.

Mandate A.6.7.2:

Non-reusable packaging components weighing more than 25 grams shall be possible to separate into single material types without the use of tools.

Exempted is reusable packaging.

The following information shall be submitted to an approved verifier:

A written guarantee that the mandate above is fulfilled. The guarantee shall be signed by the responsible person at the *brand owner* company.

The following information shall be submitted with the application to TCO Development:

A copy of a verification report from a verifier approved by TCO Development.

We hereby guarantee that the above mandate is fulfilled.

.....
Product brand name

.....
Model name(s) or "All products"

.....
Signature

.....
Name and title in block capitals

.....
Date (Declaration valid 1 year from date)

.....
Brand Owner Company

A.7 Corporate Social Responsibility

A.7.1 Corporate Social Responsibility

Background

Expectations for Corporate Social Responsibility (CSR) performance are increasing from customers and institutions. As part of the development towards being a true sustainability label, TCO Development is now introducing an extended mandate regarding supply chain responsibility.

TCO Development is supporting the OECD Guidelines for Multinational Enterprises ISO 26000 as references for working with social responsibility.

The CSR component of the TCO standard focuses on working conditions in the production of the TCO certified products.

TCO Development is primarily verifying the Brand owner's procedures for promoting legal and human labour standards in the supply chain as specified in the mandate but reserves the right to conduct supplier audits at production facilities. Also, the Brand owner should demonstrate commitment to corporate social responsibility.

Definitions

Brand owner: The company or organization owning or controlling the Brand Name.

Brand Name: The name or sign, including but not limited to a trademark or company name, used to identify, amongst users and customers, the manufacturer or seller of a Product.

1st tier production facility: Manufacturing plant where the final assembly of the TCO certified product is taking place.

Applicability

The Brand owner.

Clarification

B.7.1.1 – B.7.1.6

References

14, 15 and 16

Mandate A.7.1:

The *Brand owner* shall demonstrate the TCO Certified product is manufactured under working practices that promote good labour relations and working conditions by proving accordance with the following:

- ILO:s eight core conventions 29, 87, 98, 100, 105, 111, 138 and 182.
- UN Convention on the Rights of the Child, Article 32.
- the health and safety legislation in force in the country of manufacture, and
- the labour law, including rules on minimum wage and the social security protection in the manufacturing country.

In situations where the right to freedom of association and collective bargaining are restricted under law, workers shall be permitted to freely elect their own representatives. Reasonable effort shall be made to ensure that the requirements of this standard are being met by suppliers and subcontractors throughout the supply chain.

The brand owner accepts that TCO Development may conduct/commission on-site inspections and receive full audit reports as part of the application to verify that the *Brand owner* is fulfilling its obligations according to this Mandate. For the social audit reports and on-site-inspections, the requirement is limited to the *1st tier production facility*.

The following information shall be submitted to a verifier approved by TCO Development:

1. The requirement is fulfilled by one of the following options (a-d):
 - a) The *Brand owner* is a member of EICC and provides documented proof of third party audits conducted at production facilities of TCO certified products.
 - b) The *Brand owner* is SA8000 certified or carrying out the production at SA8000 certified facilities and provides documented proof of third party audits conducted at production facilities of TCO certified products.
 - c) The *Brand owner* shall complete the Self-documentation according to a questionnaire provided by TCO Development and provide documented proof of third party audits conducted at production facilities of TCO certified products.
 - d) The *Brand owner* applies for a 12 month grace period by submitting a signed declaration stating which option above (a, b or c) shall be implemented by them and an estimation of when all the necessary documented proof will be available.
2. A written guarantee that the above mandate is fulfilled. The guarantee shall be signed by the responsible person at the *Brand owner* company.

The following information shall be submitted with the application to TCO Development: A copy of a verification report from a verifier approved by TCO Development.

- Option (to be verified):
- 1. Member of EICC
 - 2. SA8000 certified
 - 3. Self-documentation/TCO Development questionnaire
 - 4. 12 months grace period

We hereby guarantee that the above mandate is fulfilled.

| | |
|--|---|
| Product brand name | Model name(s) or "All products" |
| Signature | Name and title in block capitals |
| Date (Declaration valid 1 year from date) | Brand Owner Company |

A.7.2 Senior Management Representative

Background

It is extremely beneficial to both parties that an open and transparent dialogue between TCO Development and Brand owner exist for the monitoring of the criteria or when issues concerning working conditions at production facilities require clarification. A contact person responsible for the organization's efforts to enforce the CSR requirements needs to be consistently available for dialogue with TCO Development throughout the certification period.

Definitions

Brand owner: The company or organization owning or controlling the *Brand Name*.
Brand Name: The name or sign, including but not limited to a trademark or company name, used to identify, amongst users and customers, the manufacturer or seller of a Product.

Applicability

The Brand owner.

Clarification

B.7.2

Mandate A.7.2:

The Brand owner shall have an appointed senior management representative who, irrespective of other responsibilities, shall ensure that the requirements of this mandate are met. The contact details of this person shall be submitted and the person shall be available for dialogue in English with TCO development throughout the certification period.

The following information shall be submitted to a verifier approved by TCO Development:

1. Name, Title, Telephone Number and Email Address of the senior management representative available for dialogue in English with TCO Development around CSR issues.
2. A written guarantee that the above mandate is fulfilled. The guarantee shall be signed by the responsible person at the Brand owner company

The following information shall be submitted with the application to TCO Development:

A copy of a verification report from a verifier approved by TCO Development.

We hereby guarantee that the above mandate is fulfilled.

.....
Product brand name

.....
Model name(s) or "All products"

.....
Signature

.....
Name and title in block capitals

.....
Date (Declaration valid 1 year from date)

.....
Brand Owner Company

R References

International standard organisations referred to in the reference list below and their Web sites.

- ASTM, American Society for Testing and Materials, <http://www.astm.org/>
 - CIE, Commission Internationale de l'Eclairage, International Commission on Illumination, www.cie.co.at/cie/
 - DIN, Deutsches Institut für Normung e. V., www2.din.de
 - EBU, European Broadcasting Union, http://www.ebu.ch/tech_info.html
 - IEC, International Electrotechnical Commission, www.iec.ch
 - ISO, International Organization for Standardization, <http://www.iso.org/>
 - ITU, International Telecommunication Union www.itu.int/home/index.html
 - SMPTE, Society of Motion Picture Television Engineers, www.smtpe.org
 - VESA, Video Electronics Standards Association, www.vesa.org
1. The most recent TCO display standard Flat Panel Displays available at <http://www.tcodevelopment.com>
 2. Nordic Guidelines for Computer Accessibility, Second edition, 1998. Nordic Cooperation on Disability. Editor: Claes Thorén.
 3. ISO 7779:2010, Acoustics – Measurements of airborne noise emitted by computer and business equipment. This international standard is based on ECMA-74.
 4. ISO 3741:2010, Acoustics – Determination of sound power levels of noise sources using sound pressure – Precision methods for reverberation rooms.
 5. ISO 3744:2010, Acoustics – Determination of sound power levels of noise sources using sound pressure - Engineering method in an essentially free-field condition over a reflecting plane.
 6. ISO 3745:2003, Acoustics – Determination of sound power levels of noise sources – Precision methods for anechoic and semi anechoic rooms.
 7. ISO 11201:2010, Acoustics – Noise emitted by machinery and equipment – Measurement of emission sound pressure levels at a work station and other specified positions – Engineering method in an essentially free field over a reflecting plane.
 8. ISO 9296:1998, Acoustics – Declared noise emission values of computer and business equipment.
 9. Standard ECMA-74 8th edition, Measurement of Airborne Noise Emitted by Information Technology and Telecommunications Equipment.
 10. EN 60950-1 (IEC 60950-1). Safety of information technology equipment including business equipment.
 11. EMAS EU regulation no 761/2001 concerning the voluntary participation of industrial companies in the Union's environmental control and review structure.

12. ISO 14001 Environmental management systems - Specification with guidance for use
13. –
14. TCO Certified Own Work questionnaire and assessment guidelines
15. Electronic Industry Citizenship Coalition (EICC), <http://www.eicc.info>
16. SA8000, <http://www.sa-intl.org>
17. www.energystar.gov and
(http://www.energystar.gov/index.cfm?c=partners.pt_index)
18. International Efficiency Marking Protocol for External Power Supplies
19. EU Directive 2006/66/EG on batteries and accumulators containing certain dangerous substances
20. EU Directive 2002/95/EC on the restriction of the use of certain hazardous substances in electrical and electronic equipment
21. Proposal for an EU Directive 2003/0282 (COD) on batteries and accumulators and spent batteries and accumulators
22. Regulation concerning Registration, Evaluation, Authorisation and Restriction of Chemicals (REACH), EC 1907/2006
23. EU Directive 67/548/EEC on the approximation of laws, regulations and administrative provisions relating to the classification, packaging and labelling of dangerous substances
24. EU Directive EC 1272/2008 on classification, labelling and packaging of substances and mixtures
25. The EU Green Paper “Environmental questions concerning PVC” KOM (2000) 469
26. EU Directive 91/155/EEC and amendments defining and laying down the detailed arrangements for the system of specific information relating to dangerous preparations
27. EU Directive 93/793/EEC on the evaluation and control of the risks of existing substances
28. ISO 11469 Plastics - Generic identification and marking of plastics products
29. ISO 1043-1, -2, -3, -4 Plastics - Symbols and abbreviated terms
30. EU Directive 2002/96/EC on waste electrical and electronic equipment (WEEE)
31. Directive 94/62/EC on packaging and packaging waste.

B Test Methods and clarifications

The following definitions, test conditions, requested specifications from clients, and other information apply to the test methods described in this document.

Test results are valid only for the presentation form(s) and configuration(s) tested.

B.0 General test conditions

B.0.1 Definition of a test object

- Test objects covered by this document are different styles of computer such as Desktop or Desk-side (Tower)
- The testing procedures are the same and so as to simplify the instructions in this Section of the document, both styles will be referred to as EUT (Equipment under Test).
- A test object with all necessary information for its operation shall be delivered to the to the test laboratory in test-ready condition including any required accessories. All necessary information about how to operate and adjust the test object shall be provided.
- The performance of the EUT shall in all aspects be fully in accordance with the performance of the final product.

B.0.2 Required test object information

- The client shall specify the name(s), type designation(s) and manufacturer for all different exchangeable parts of the test object.
- The client shall specify the name, type designation and manufacturer of the graphics card. This information shall be written in the test report.
- The graphics card used for testing shall not be used for more than the test object during the test, if not stated by the client.
- The EUT used to run the display shall not use any unnecessary software or hardware that could influence the test.

B.0.3 Conditions for the EUT

- The EUT shall be physically prepared for testing and shall be warmed up for 30 minutes before testing.
- All testing shall be performed with the EUT connected to a VDU of FPD type certified in accordance with the most recent version TCO standard for displays. The monitor shall be adjusted and display an image as specified in each relevant part of the display standard.

- The wiring connecting the EUT with the display, and the display's own power supply arrangements shall be arranged in a way that the influence on the performed measurements is minimized.
- Only equipment that is necessary for the functionality of the EUT should be connected to such external ports as USB and Fire Wire, unless stated by the manufacturer.
- The EUT shall be tested under nominal conditions of input voltage, current, etc. If sold on different markets, one setup shall be chosen by the manufacturer which shall represent the conditions of the country there the product shall be sold the most.
- When possible testing shall be done with the digital signal input. In the case of several digital inputs the one with the lowest bandwidth which can still support the native resolution shall be used. The same signal input shall be used for testing of all parameters. The signal input used shall be specified in the test report.

B.0.4 Instruments used for testing

All instruments used for testing the EUT shall be of good quality and validated by a recent test certificate from a certified testing laboratory. Any necessary instrument calibration shall be done before the tests are performed. Calibrations shall be traceable to national standards

B.0.5 Settings of the EUT

- All test images can be found on the home page of TCO Development, www.tcodevelopment.com.
- The default testing 12 point Arial font and 100% "zoom/magnification" shall be used. The latest version of MS Windows operating system is the default user interface, if not otherwise stated. For Macintosh computers, Mac OS can be used during testing. The operating system most likely to be used by an end user should be used for testing.
- No programs to enhance the image quality or in any other way improve the results should be run on the EUT during test unless they are intended to be delivered with the final product.
- The CPU, GPU and memory clock frequencies should be set by the manufacturer as intended for the end user.
- All chassis modifications such as dust filters, perspex windows or extra fans are to be installed as intended for the end user.

B.0.6 Test report

- The test results are valid only for the presentation form(s) and configuration(s) tested. If other configurations are accepted by the laboratory based on the results of the tested ones it shall be clearly specified in the test report that these configurations have not been tested.
- Any changes to the test methods shall be stated in the test report.
- The manufacturer, brand name, model type and serial number, if available, shall be stated in the test report.
- The supply voltage and frequency used during the test and the electrical safety classification CLASS I or CLASS III shall be stated in the test report.
- The degree of uncertainty for each given measurement result shall be stated in the test report.
- Photographs of the product showing: Front, side, rear, a legible marking label and if applicable the external power supply with legible marking label.

B.1 General Information

B.1.1 TCO Certified Document

The TCO document shall accompany the product as provided by TCO Development. No editorial changes without TCO's consent are accepted. The TCO Document is available at the TCO Development web site www.tcodevelopment.com.

If the TCO Document is part of a User's Manual or is provided as an electronic file the TCO Document must be separated from other text portions so that it is obvious that the TCO Document is not accountable for the content of the other texts.

The brand name owner may post the TCO Document on its web site, e.g. by showing TCO logos or icons that redirect the visitor by links to the TCO Certified Document

If the product that is to be TCO Certified labelled is branded differently from the applicant name, the applicant company signing the guarantee shall be sure that the brand name holder agrees with the requirement.

B.2 Visual ergonomics

B.2.1 Display resolution requirement

The test laboratory engineer may check the product's specifications to confirm that it meets the mandate. If specifications do not exist then the test lab shall connect the computer to a display to confirm that the mandate is met.

B.4 Emissions

B.4.0 General test conditions for emissions

B.4.0.1 Basic test requirements

As described in section B.0.

For the test methods for emissions described in this document the following conditions apply:

- AC mains voltage* 230 VAC RMS, tolerance $\leq 1\%$
- AC mains frequency* 50 Hz, tolerance $\leq 2\%$
- Test room temperature $23\pm 3\text{ }^{\circ}\text{C}$
- Humidity 20-75 % RH (non condensing)

The EUT shall be connected to phase and neutral.

* – or other voltage and frequency combination specified by the client.

B.4.0.2 Conditions and set up for the test object

The tests on the EUT shall be performed with the full screen size of the connected display activated. The display shall be in its default setting and show a full screen of capital “H” pattern in dark/black letters on an illuminated background (positive polarity).

The EUT shall be connected to mains via a mains cord. The measurement shall be performed with a non-shielded mains cord of normal type, (connected to earth for a CLASS I device). A shielded power cord may be used if the cord is permanently attached to the computer or adapter. Permanently attached means that tools are necessary to remove and change the cord or when all the 2 following conditions are met:

1. The shielded power cord is delivered with the PC
2. The manual contains information that the PC will only fulfil the TCO requirements when used with the shielded power cord and/or,

Written information is supplied to the end user that the product will only fulfil the TCO requirements with the shielded power cord. Information should be provided in the box together with the shielded power cord or attached to the shielded power cord.

EUTs without an external power supply shall be connected to mains via the above mentioned power cable, which shall run from the point of its connection on the EUT horizontally straight to a point 0.4 m behind the front of the EUT. The cable shall then from this point run downwards at least 1 m. – see figure B.4.0.2.1 However, the cable at this vertical drop should never be closer than 0.1 m to the back of the EUT. So for an EUT with a depth (front to back) ≥ 0.3 m the distance 0.1 m from the back is used instead of 0.4 from the front.

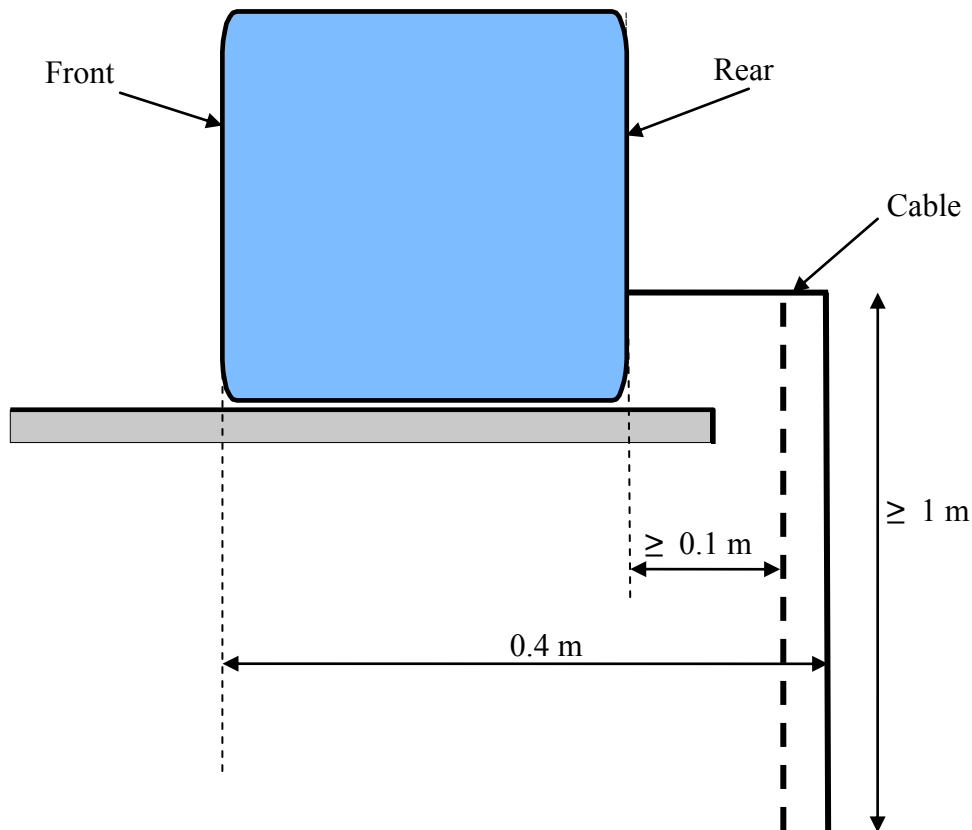

Figure B.4.0.2.1 EUT without external power supply and a depth of < 0.3 m.

An external power supply unit can contribute to the electromagnetic fields around the EUT. Power supply units, which are connected via a primary cable to the outlet, shall be positioned centrally, directly behind the test sample, on the (turn)table, with the secondary side towards the EUT, see Figure B.4.0.2.2 The primary cable shall extend horizontally, on the (turn)table to a point 0.4 m behind the front of the EUT. The cable shall then, from this point run downwards for at least 1 m. However, the cable at this vertical drop should never be closer than 0.1 m to the back of the EUT. So for a large EUT the distance 0.1 m from the back is used instead of 0.4 from the front. If the power supply can be positioned with different sides up, it shall be tested in all positions and the worst case shall be used. However, if it is obvious which side is intended to be the top side or bottom side by the placement of LED indicator or integrated supports to stand on, it is enough to test the power supply in the one intended position.

The secondary cable of the power supply shall run the shortest distance from the point of its connection on the EUT to the secondary side of the power supply. The unused portion of the secondary cable, if any, shall be bundled together with the power supply unit. The bundle loops shall have a length equal to the longest dimension of the power supply. For supply units with dimensions less than 0.1 m; a 0.1 m bundle loop length shall be used.

For power supply units which are designed to be put directly in the outlet, without a primary cable, the secondary cable shall run vertically down to the (turn)table from

the point of its connection on the EUT and then horizontally straight to a point 0.4 m behind the front of the EUT. The cable shall then, from this point, run downwards at least 1 m.

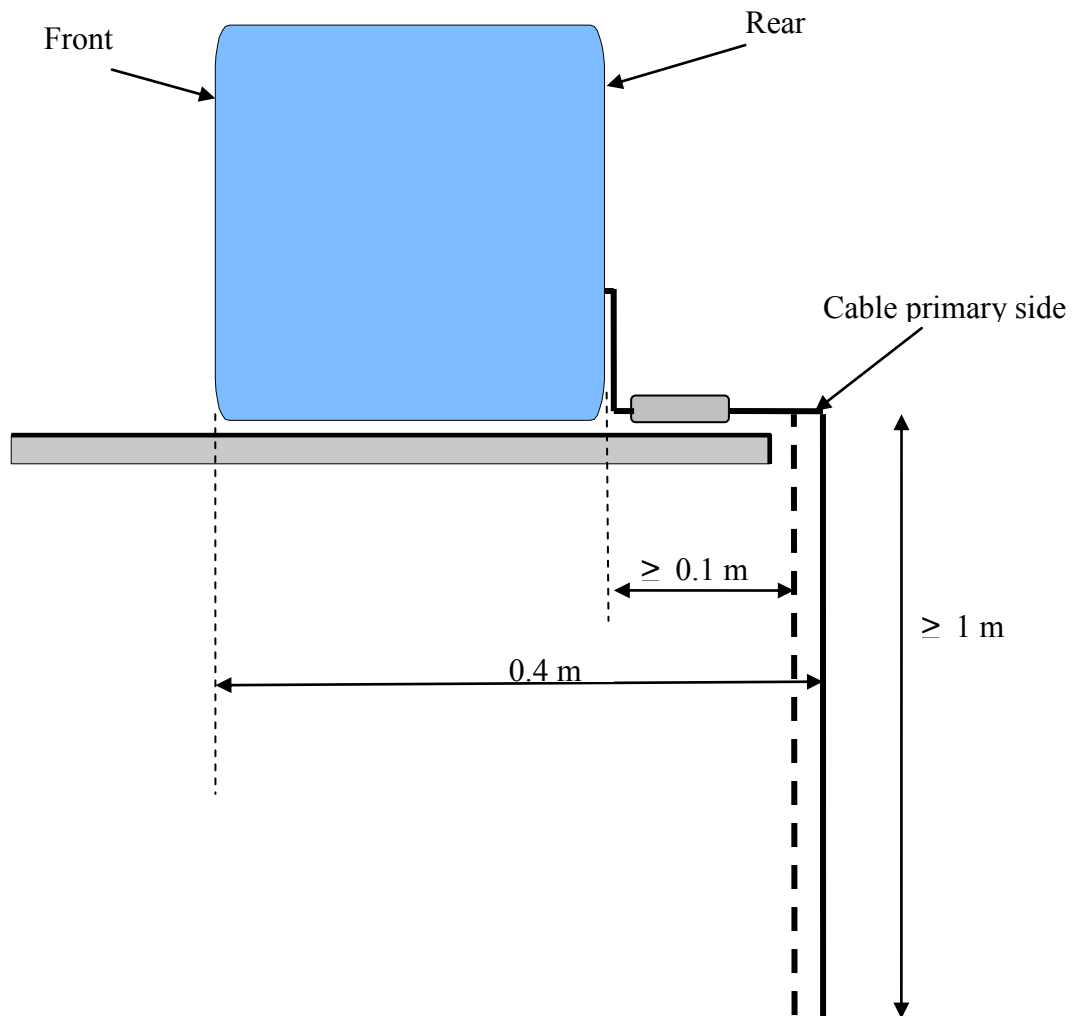

Figure B.4.0.2.2 EUT with external power supply.

For measurements of alternating magnetic fields (B.4.2) the power cable may be positioned in another way, as the cable contributes a negligible amount to the magnetic field. However external power supplies must be correctly positioned, as they may give rise to magnetic fields.

If positioning in accordance with the above rules is not possible, the positioning of the supply unit and cables shall be described in the test report.

B.4.0.3 Emission measurement instruments

The instruments used for emission testing shall comply with the requirements and calibration procedures described below:

Alternating electric field meter

The alternating electrical field emission from the EUT shall be determined by measuring the displacement current passing a given surface of the measuring probe. The probe consists of a disc of double sided printed circuit board laminate with a diameter of 300 mm. On the front of the board the copper layer is removed in the annulus between radii 50 and 52 mm, see Figure B.4.0.3.1.

The copper foil surrounded by the annulus is the active measuring surface. It is connected to one input terminal of an operational amplifier, with capacitive feedback. The other input terminal of the operational amplifier, the copper ring outside the active surface, and the back of the board are connected to ground. The output voltage (U) from the probe (active surface with area (A)) is related to the incident electrical field, E, averaged over the active surface in accordance with $U = \epsilon \cdot E \cdot A/C$ where C is the capacitance in the feedback loop of the operational amplifier and ϵ is the permittivity for a vacuum.

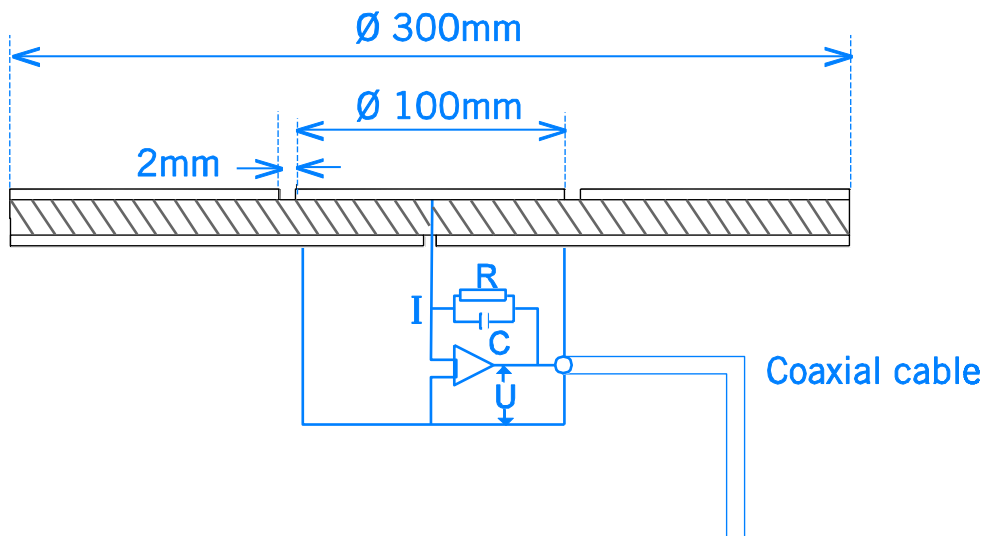

Figure B.4.0.3.1 Sketch and circuit principle of the Alternating electric field meter for alternating electrical field measurements. The feedback circuit of the operational amplifier is a capacitance C in parallel with a high value resistor R to ensure that there is no DC voltage across the plates of the capacitor C.

The specifications for the frequency response of the alternating electric field meter are given by the calibration procedure. The signals from the probe shall be filtered by high-pass and low-pass filters. The specification of the filters is given in Table B.4.0.3.1.

Table B.4.0.3.1 Filter specifications

| | | | | | |
|-------------------------|----------------|------|--------|-------|----------------|
| Frequency Band I | | | | | |
| Frequency | < 5 Hz | 5 Hz | 100 Hz | 2 kHz | > 2 kHz |
| Attenuation | > 80 dB/decade | 3 dB | 0 dB | 3 dB | > 40 dB/decade |

| | | | | | |
|--------------------------|----------------|-------|--------|---------|----------------|
| Frequency Band II | | | | | |
| Frequency | < 2 kHz | 2 kHz | 30 kHz | 400 kHz | > 400 kHz |
| Attenuation | > 80 dB/decade | 3 dB | 0 dB | 3 dB | > 40 dB/decade |

After amplification and filtering the output voltage of the measuring probe shall be used to determine the r.m.s. value of the electric field strength in both frequency bands.

The measuring time shall be sufficiently long to enable measurements with an accuracy of $\pm 5\%$ at 50/60 Hz.

The measuring system shall be capable of measuring at least down to 2.0 V/m in Band I and down to 0.20 V/m in Band II.

The measuring probe shall be calibrated using a parallel plate capacitor (air dielectric) consisting of the measuring probe and a metal plate of at least 300 mm diameter. The distance between the surface of the probe and the plate shall be 30 mm.

The calibration shall be performed with sinusoidal fields at the amplitudes and frequencies specified in Table B.4.0.3.2.

Table B.4.0.3.2 Calibration frequencies and amplitudes

| | Frequencies | Amplitude |
|----------------|-----------------------|------------------|
| Band I | 50, 100, 500, 1000 Hz | 10, 25 V/m |
| Band II | 15, 30, 60, 120 kHz | 1.0, 2.5, 10 V/m |

Recorded values at these calibration points shall be within $\pm 5\%$ of the nominal value. Due to the nature of the specified filters the deviation shall be calculated at 1 kHz from 9.5 and 22.5 V/m and at 120 kHz from 0.95, 2.4 and 9.5 V/m.

Alternating magnetic field meter in Band I and Band II

The magnetic field shall be measured using coil systems that shall consist of three mutually perpendicular concentric circular coils each with an area of 0.01 m². The coils may depart from a circular shape where they intersect. The minimum inner diameter shall be 110 mm and the maximum outer diameter 116 mm. The measuring coils shall not be sensitive to electric fields.

The resonance frequency of each coil appropriately connected to cables and amplifiers shall not be so low that it may influence the specified frequency response according to table B.4.0.3.1.

Amplifiers and integrating networks to make the output voltage proportional to the magnetic flux density and independent of frequency shall follow each coil. The specifications in respect of the frequency response are given in the calibration procedure.

High-pass and low-pass filters shall filter the signals from the coil systems. The specifications of the filters are given in Table B.4.0.3.1.

After amplification, integration and filtering, the signals from the three coils in each coil set shall be used as input values for calculating the r.m.s. values of the amplitudes of the magnetic flux density vectors in both frequency bands. It is permissible to calculate the r.m.s. value for each of the coil signals and use the root of the squared sum of those r.m.s. values as the test result.

The measuring time shall be sufficiently long to enable measurement with an accuracy of $\pm 5\%$ at 50/60 Hz.

The alternating magnetic field meter in Band I and Band II shall be capable of measuring down to at least 40 nT in Band I and down to 5.0 nT in Band II.

The alternating magnetic field meter in band I and band II shall be calibrated using a Helmholtz-type calibration coil as shown in the Figure B.4.0.3.2. Calibration set-up: Calibration shall be performed with sinusoidal fields at the amplitudes and frequencies specified in Table B.4.0.3.3.

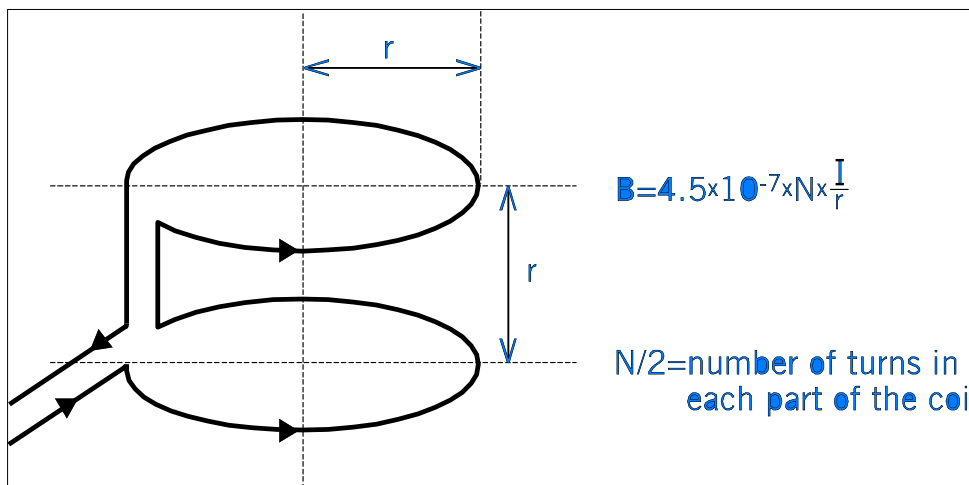

Figure B.4.0.3.2. Calibration using a Helmholtz-type calibration coil.

Table B.4.0.3.3 Calibration frequencies and amplitudes

| | Frequencies | Amplitudes |
|----------------|-----------------------|-------------------|
| Band I | 60, 100, 500, 1000 Hz | 200, 2000 nT |
| Band II | 15, 30, 60, 120 kHz | 25, 250 nT |

Recorded values for these calibrations shall not deviate more than $\pm 5\%$ from the nominal value. Due to the nature of the specified filters the deviation at 1 kHz shall be calculated from 180 nT and 1800 nT and at 120 kHz from 24 nT and 240 nT.

The calibration shall be performed for each of the three individual coils separately exposed and for one situation where approximately the same flux density passes through all three coils.

B.4.1 Alternating electrical fields

B.4.1.0 Test laboratory requirements

Background electric field strengths in the test laboratory, including disturbances transmitted by power lines and internally generated noise in the measuring system, shall together not exceed 2.0 V/m in Band I and 0.20 V/m in Band II.

The mains voltage to the EUT under test shall be within $\pm 3\%$ of its nominal value.

B.4.1.1 Preparation of the EUT for testing

All necessary preparations described in B.0 and B.4.0 shall be done.

B.4.1.2 Equipment

Alternating electric field meter

B.4.1.3 Test Method

The EUT shall be positioned at a horizontal surface. The origin of a cylindrical coordinate system is chosen to be situated at the centre of an imaginary box just covering the EUT. The z-axis is chosen to be at a right angle to the horizontal plane. The angular reference direction is parallel to the horizontal plane and through the centre, centre point of the front of the EUT. An angle ($^{\circ}$) is positive in the counter-clockwise direction.

The true r.m.s. value of the amplitude of the electric field strength, at the surface of the measuring probe, is measured in front of the test object in Band I and in four azimuths in Band II at 0° , 90° , 180° , 270° . All measurements shall be taken at 0.5 m from an imaginary box covering the surface of the product. The measurement instrument is moving in a counter-clockwise direction around the test sample (as illustrated in the figure B.4.1.3.1). The frequency ranges are selected by means of filters in the measuring equipment.

Distances are given in meters and angles in degrees. The co-ordinates are given for the centre of the measuring probe. The surface of the probe shall be perpendicular, within $\pm 5^{\circ}$, to the radial axis.

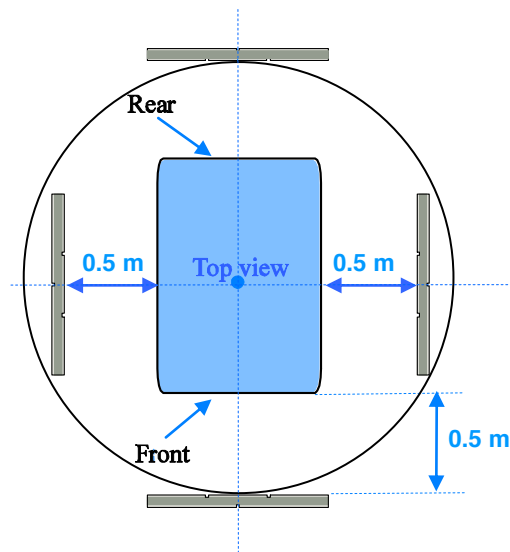

Figure B.4.1.3.1. Measurement geometry for Band I and Band II.

The EUT and the measuring probe shall be positioned at least 1 m from all significant metallic structures and objects.

Additional units and connecting cables necessary for the operation of the EUT, which are not part of the test, shall be placed so far away from the measuring setup that the fields they emit do not influence the measurement. Shielding may be added to these units and cables, as long as the 1 m clearance is maintained.

The measuring probe shall be connected to ground. Any eventual cables running between the measuring probe and the measuring instrument shall be positioned in such a way that they do not influence the measured value.

The power cable of the EUT shall be connected to the phase and the neutral conductors of the mains power supply. If the mains power supply plug permits an interchange of the live and neutral conductors, measurements shall be taken with the connection that gives the highest reading in Band I.

B.4.1.4 Test evaluation

Results shall be presented as r.m.s. values of the alternating electric field expressed in volt per meter (V/m). For Band I, results shall be presented as the measured values for normal and stand-by operations if they differ. For Band II, the measured values in front of the EUT and the maximum value at rotation shall be presented for normal and stand-by operations if they differ.

If the measured values are less than 10.0 V/m in Band I or less than 1.0 V/m in Band II the result shall be reported as “<_10.0 V/m” or “<_1.0 V/m” respectively.

B.4.1.5 Overall uncertainty

The test shall be performed in such a way that the total extended uncertainty in the test result will be less than \pm (10 % of the reading + 1.5 V/m) for Band I and \pm (10 % of the reading + 0.1 V/m) for Band II.

B.4.2 Alternating magnetic fields

B.4.2.0 Test laboratory requirements

Background magnetic fields in the test laboratory, including disturbances transmitted along the power line and internally generated noise in the measuring system, shall together not exceed 40 nT in Band I and 5 nT in Band II.

B.4.2.1 Preparation of the EUT for testing

All necessary preparations described in B.0 and B.4.0 shall be done.

B.4.2.2 Equipment

Alternating magnetic field meter in Band I and Band II

B.4.2.3 Method

The true r.m.s. value of the amplitude of the magnetic flux density vector is measured at 12 points on a cylindrical surface around the test object in the two frequency ranges, Band I and Band II. The frequency ranges are selected by specified filters in the alternating magnetic field meter.

The measuring geometry is illustrated in Figure B.4.2.3.1. The measurement points are mathematically defined in the following way.

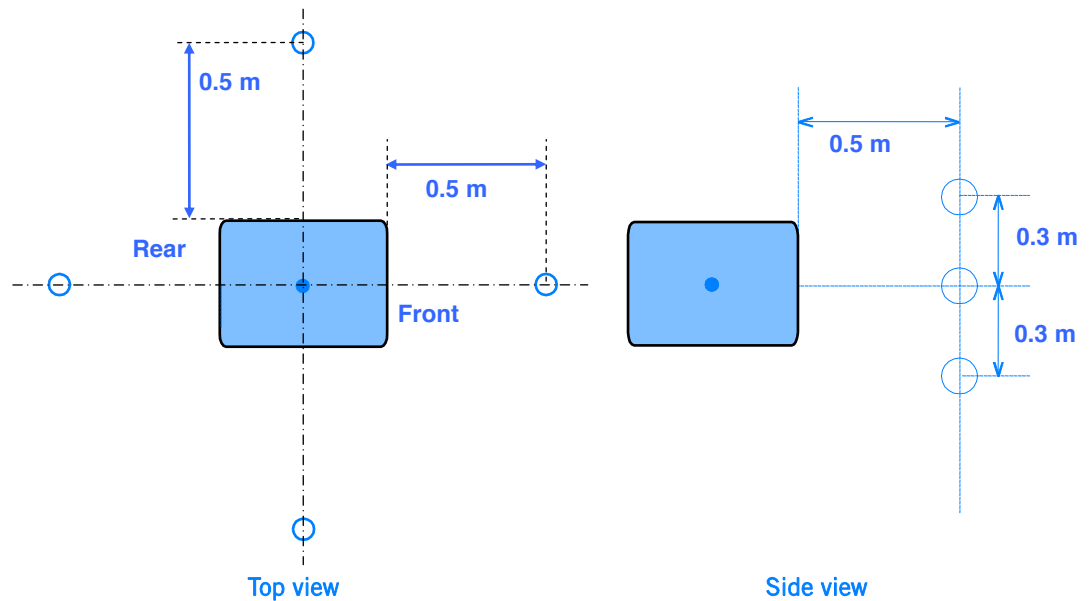

Figure B.4.2.3.1. Measurement geometry for the EUT.

The EUT shall be positioned at a horizontal surface. The origin of a cylindrical coordinate system is chosen to be situated at the centre of an imaginary box just covering the EUT. The z-axis is chosen to be at a right angle to the horizontal plane. The angular reference direction is parallel to the horizontal plane and through the centre, centre point of the front of the EUT. An angle ($^{\circ}$) is positive in the counter-clockwise direction.

The test co-ordinates are taken in four directions around the EUT at 0°, 90°, 180° and 270°. Measurements shall be made at these points 0.50 m from an imaginary box just covering the outer surface of the EUT. The measurement instrument is moving in a counter-clockwise direction around the test sample (as illustrated in the figure B.4.2.3.1).

Distances are given in metres and angles in degrees.

The measuring coils shall be stationary during the measurements.

The power cable of the test object shall be connected to the phase and the neutral conductors of the mains power supply. The EUT does not need to be measured with the phase and neutral interchanged in this case, as the magnetic fields are not influenced by such a change.

B.4.2.4 Test evaluation

Results shall be presented as r.m.s. values of the magnetic flux density expressed in nanotesla (nT) for the two frequency Bands. The values in front of the EUT and the maximum value and its position shall be given both for normal and for standby operation if they differ. If measured values are less than 200 nT in Band I or less than 25.0 nT in Band II the result shall be reported as “<200 nT” and “<25.0 nT” respectively.

B.4.2.5 Overall uncertainty

The test shall be performed in such a way that the total extended uncertainty in the test result will be less than $\pm(10\% \text{ of the reading} + 30 \text{ nT})$ for Band I and $\pm(10\% \text{ of the reading} + 1.5 \text{ nT})$ for Band II.

Note

The uncertainties given are worst case limits. In many cases it will be possible to obtain better accuracy, especially in Band II.

B.4.3 Acoustic noise

The acoustic noise test shall only be carried out if the Desktop has any internal moving mechanical parts

B.4.3.1 Method

Prior to testing, the computer shall have been switched on for 15 minutes. Switch on the computer and begin recording elapsed time, starting either when the computer is initially switched on, or immediately after completing any log in activity necessary to fully boot the system. Once logged in with the operating system fully loaded and ready, close any open windows so that the standard operational desktop screen or equivalent ready screen is displayed. Exactly 15 minutes after the initial boot or log in, start to accumulate test noise levels.

The noise measurements shall follow ISO 7779:2010 and shall be declared according to ISO 9296:1988. (However the principle for how the measurement uncertainty is handled shall be the same as for all the other criteria in this TCO Certification. This means that no uncertainty shall be added to the result presented in the report.)

In addition to reporting the measured *A-weighted sound power level* (L_{WA}) in Bels (B) the single measurement values of the 9 measurement positions and the mean value of these *A-weighted sound pressure level* (L_{pA}) in Decibels (dB) have to be included in the test report.

B.4.3.2 Overall uncertainty

The test shall be performed in such a way that the total extended uncertainty in the test result will be less than ± 2.5 dB.

Note

The uncertainties given are worst case limits. In many cases it will be possible to obtain better accuracy.

B.6 Environmental requirements

B.6.0 General Clarification

B.6.0.1 Signatures

The templates in the ecological declaration shall be sent either with original signatures or as copies of original documents with original signatures. “Copies” are for example telefaxes or pdf-files of scanned signed documents. TCO Development and/or the responsible laboratory may later request the original signed document.

However, copies will not be accepted where the signature has been scanned and pasted into the document.

TCO accepts digital signature as an alternative to traditional signature on test reports and declarations submitted as pdf files. To approve a digital signature it is necessary to also submit a digital key to the verifier to facilitate identification.

B.6.1 Product description

The type key for unidentified characters, if any, in the model name and panel identification name shall be submitted. The type key must include two or more options.

The type key that includes an Asterisk (*) for unidentified characters, if any, in the model name and panel identification name shall be submitted to the verifier. Only two * may be used in the model type key and each * must include two or more options. For the most up-to-date information about type keys, see the appropriate product Application Process at www.tcodevelopment.com

B.6.2 Organisation

B.6.2.1 Environmental management system certification

The certificate shall be issued by a certification body that is accredited by an accreditation body covered by the International Accreditation Forum, www.iaf.nu, Multilateral Arrangement on Environmental Management Systems.

For applicants submitting several applications, it is enough to attach an ISO 14001 certificate or EMAS registration with the first application.

The certificate or an appendix to the certificate shall show the scope of the certification.

B.6.3 Climate

B.6.3.1 Energy consumption – Desktop computer

TCO Development requires testing by a test laboratory approved by TCO Development. Testing shall be done according to the most recently published version of the Energy Star standard for computers and concerns only the Energy consumption requirements. The product does not have to be certified according to Energy Star.

The “Power supply efficiency requirement”

If the product has an Energy Star certificate, the TCO Development accepted test laboratory can base the test report on this certificate to show compliance with the Energy Star “Power supply efficiency requirement”. For products without Energy Star certificate the “Power supply efficiency requirement” may be tested by any laboratory accredited according to ISO 17025 and considered acting as a third party.

Test conditions, Supply Voltage

If the product has an Energy Star certificate TCO Development only require that one of the voltages is tested at a laboratory accepted by TCO Development. Other supply voltages may be verified through the existing Energy Star certificate. For products without Energy Star certificate all supply voltages must be tested at a laboratory accepted by TCO Development. The Supply Voltage shall be recorded in the test report.

The “Power management requirements”

The TCO Development accepted test laboratory can base the test report on a declaration from the manufacturer that the Energy Star “Power management requirements” are fulfilled.

B.6.3.1.1 Exemptions from the Energy Star standard

All exceptions and special requirements, test methods etc. specified by Energy Star are also accepted by TCO Development.

If testing concerns an update of an original certification (additional critical component that requires re-test) that was issued to an older version of an Energy Star standard, then that older version may be used for testing.

Amounts of samples for testing

According to the TCO Certified criteria the manufacturer is responsible that the whole batch fulfils the demands. Further the test is performed at a third party laboratory. Therefore TCO Development accepts the test of only one sample even if the result is very close to the limit value.

B.6.3.2 Energy consumption – external power supply

TCO Development has decided that energy consumption of the external power supply shall follow the U.S. Environmental Protection Agency’s (EPA) demands for compliance with The International Efficiency Protocol requirement for level V, equivalent to the Energy Star version 2.0 for external power supplies, also covering battery chargers.

The international efficiency mark consists of a Roman numeral (I – VI) that corresponds to specific minimum Active and No-Load efficiency levels (as well as a power factor requirement for level V) and is printed/applied by the manufacturer on the external power supply marking label.

A TCO Development laboratory will require to see a copy of the external power supply marking label there The International Efficiency Protocol requirement for level V symbol is visible as proof of compliance.

B.6.4 Environmentally hazardous substances

B.6.4.1 Cadmium (Cd), mercury (Hg), lead (Pb) and hexavalent chromium (CrVI)

Exemptions are according to EU Directive 2011/65/EU (RoHS) and the documents supporting the directive.

The maximum concentration values tolerated by weight in homogeneous materials for cadmium, mercury, lead and hexavalent chromium are according to EU Directive 2011/65/EU (RoHS) and the documents supporting the directive.

The limit value for batteries are according to this is 0,0005 % for mercury and 0,002 % for cadmium per listed part, according to EU Directive 2006/66/EG.

TCO Development supports the use of recycled plastic. To avoid making it more difficult to use recycled plastic, exceptions to this requirement can be accepted. If recycled plastic is used in the product please contact TCO Development for further instructions.

B.6.4.2 Halogenated substances

Mandate 1. The requirement applies to plastic parts in all assemblies and sub-assemblies.

Exempted are printed wiring board laminates, electronic components and all kinds of cable insulation.

Mandate 2. The requirement applies to the whole of the Desktop computer, including components, parts and raw materials in all assemblies and sub-assemblies e.g. batteries, paint, surface treatment, plastics and electronic components. Printed Wiring Boards are also included in the requirement.

HBCDD has been identified as a Substance of Very High Concern in accordance with EU REACH criteria. The main application of HBCDD in EEE is as a flame retardant in HIPS plastic being used for closures and structural parts of different types of EEE. TCO Development considers that the use of HBCDD in EEE is not deemed essential as technically suitable alternative substances and materials are available and already used extensively today.

Maximum concentration values tolerated for a restricted substance (including decaBDE) is 0.1 % by weight in homogeneous materials.

TCO Development supports the use of recycled plastic. To avoid making it more difficult to use recycled plastic, exceptions to this requirement can be accepted. If

recycled plastic is used in the product please contact TCO Development for further instructions.

B.6.4.3 Non-halogenated substances

Classification, Labelling and Packaging of Substances and Mixtures, known as the CLP Regulation came into force January 2009. The new regulation will eventually replace the Dangerous Substances Directive 67/548/EEC and Dangerous Preparations Directive 1999/45/EC. The transitional dates from which substance classification & labelling must be consistent with the new rules is 1 December 2010 (2012 if the substance is already on the shelves) and 1 June 2015 (2017) for mixtures (preparations).

Maximum concentration values tolerated for a restricted substance is 0.1 % by weight in homogeneous materials.

TCO Development supports the use of recycled plastic. To avoid making it more difficult to use recycled plastic, exceptions to this requirement can be accepted. If recycled plastic is used in the product please contact TCO Development for further instructions.

It takes time for the industry to phase hazardous substances out of productions. To give some preparation for that, the following list of substances are planned to be restricted in the next version of TCO Certified (*estimated publication Q1 2014*). *The complete table with references and further information can be provided by TCO Development upon request.*

| Likely banned substances in the next version TCO Certified | | |
|---|-------------|--|
| English name | CAS | Hazard statements |
| Antimony(III) oxide (Sb ₂ O ₃) | 1309-64-4 | H351 |
| Tri-o-cresyl phosphate | 78-30-8 | H411, H370 |
| Triethyl phosphate | 78-40-0 | H341, H350, H302, H319 |
| Magnesium hydroxide | 1309-42-8 | H372, H315, H319, H335, H302, H332, H318, |
| | 138265-88-0 | H410, H400 |
| Zinc borates (2ZnO.3B ₂ O ₃) | 12767-90-7 | H410, H400, H319 |
| Triphenyl phosphate (TPP) | 115-86-6 | H411, H400, H410, H413, H319 |
| Sodium toluene-4-sulphonate | 657-84-1 | H341, H351, H400, H301, H312, H317, H319, H332, H315, H335, H302, H318 |
| Bis phenolA bis (biphenyl) phosphate (BDP) | 181028-79-5 | Technical grade contains TPP |
| (1-methylethylidene)di-4,1-phenylenetetraphenyl diphosphate | 5945-33-5 | Constituent of BDP, Technical grade contains TPP |
| Tri-cresyl phosphate | 1330-78-5 | H411, H400, H410, H413, H319, H317, H361, H373, H312, H302, H370 |
| Cresyl diphenyl phosphate | 26444-49-5 | H410, H400, H302 |
| Resorcinol bis (diphenyl diphosphate) (RDP) | 57583-54-7 | H411, H412 |

B.6.4.4 Plastics with chlorine and bromine as part of the polymer

TCO Development supports the use of recycled plastic. To avoid making it more difficult to use recycled plastic, exceptions to this requirement can be accepted. If recycled plastic is used in the product please contact TCO Development for further instructions.

B.6.5 Product lifetime

B.6.5.1 Warranty and spare parts

That spare parts shall be available for three years from “the time that production ceases” is only applicable to the production of the specific notebook, certified by the brand owner.

Regarding spare parts:

1. If a part of a product is broken (e.g. outer casing) the end user shall not need to replace the whole product, only the broken part. The broken part shall be possible to replace with an equivalent part (this part does not have to be identical to the broken part).
2. When the cost for replacing a broken part exceeds the cost of replacing the whole product, then that part need not be considered as a spare part under this mandate.

B.6.6 Preparation for Recycling

B.6.6.1 Material coding of plastics

If the amount of flame retardant exceeds 1 % by weight the coding shall be complemented in accordance with ISO 1043-4.

B.6.6.2 Variety of plastics

Clarification: A different additive marking will not make the plastic a different plastic type. For example ABS with FR40 and ABS with FR50 is considered *one* plastic type (two are still allowed).

B.6.6.3 Metallization of plastic housing and metal parts

The requirement applies to the outer plastic casing of the Desktop computer. Housings for electronic components inside the outer casing are not included in the requirement.

When the virgin plastic already in its granulated form contains additives, consisting for example of metal oxides in the form of pigment or metal flakes, this is not considered to be metallization and is not included in the prohibitions defined in A.6.6.3.

Metallized plastic control buttons for the adjustment of screen contrast, brightness, colour, etc. are accepted.

Metal parts and metallized plastics parts are acceptable if they are Post Mould Inserts or Snap-Fastening type and can be easily removed using standard tools. In Mould Insert Moulding or glued metal parts are not accepted. Strong double-sided tape, difficult to separate is not accepted.

Post mould inserting is the process by which a metal insert is fixed into an already moulded plastic by means of a secondary process. Inserts may use heat fusion or deep threads to create a secure bond with the plastic.

Clarification: All exceptions on metallised parts described above must fulfil the RoHS Directive.

B.6.6.4 Take back system

Tick the box of the option chosen.

If the applicant chooses **option 1** (*Product only sold on markets with WEEE legislation or similar*) and signs the declaration, the requirement is fulfilled.

If **option 2 or 3** (*World-wide product take back or One additional market lacking WEEE legislation where product take back is offered*) is chosen, the declaration must be signed and the applicant must provide a short description of how the take-back system on that market works. This can also be done by giving a reference (for example a link to a website) to the representative, associated company or affiliate taking care of the take-back system on that market.

In case of option 3 the applicant must also provide the name of the market (country) where a take back system is provided.

TCO Development has no requirement on the take-back system being free of charge.

It is important to point out that any recycling and waste export control legislation in countries where the applicant company operates must always be met.

B.6.7 Product packaging

B.6.7.1 Hazardous substances in product packaging

Limit values are according to Directive 94/62/EC on packaging and packaging waste.

B.7 Corporate Social Responsibility

B.7.1.1 General Clarifications

TCO Development is from this version of the criteria taking the next step in relation to Corporate Social Responsibility (CSR) by introducing an extended mandate regarding supply chain responsibility, since the way in which products are produced is gaining importance for consumers as well as professional buyers. Within the ICT industry supply chain responsibility is increasingly seen as a hygiene determinant.

We aim to be a sustainability label that assures good products in three relevant areas – environmental, social and ergonomics. We want the label to be proof for compliance with public procurement ethical criteria as well as with private sector CSR policies.

The Social performance criteria are based on the eight ILO core conventions and local legislation. This stipulates minimum standards as for the situation in the production facilities. ILO (International Labour Organization) is a United Nations specialized agency with the aim to promote social justice and humane working conditions. The organization consists of representatives of national states, corporations and labour unions.

It is also important the Brand owner has an appointed senior management representative who, irrespective of other responsibilities, ensures that the requirements of this mandate are met. The contact details of this person shall be submitted and shall be available for dialogue in English with TCO Development throughout the certification period. This aims to create an open and transparent dialogue between TCO Development and the brand owner company.

B.7.1.1.1 Electronic Industry Citizenship Coalition (EICC)

The Electronic Industry Citizenship Coalition (EICC) is a group of companies working together to create a comprehensive set of tools and methods that support credible implementation of the Electronic Industry Code of Conduct throughout the Electronics and Information and Communications Technology (ICT) supply chain.

The Electronic Industry Code of Conduct is a code of best practices adopted and implemented by some of the world's major electronics brands and their suppliers. The goal is to improve conditions in the electronics supply chain. Development of the Code was a multi-stakeholder effort, influenced by internationally-recognized standards. By consolidating and standardizing compliance, audit and reporting efforts, suppliers can focus on achieving the high standards of performance set forth by the Code. This approach is also conducive to fostering a culture of social responsibility throughout the global electronics supply chain. EICC sets forth performance, compliance, auditing and reporting guidelines across five areas of social responsibility:

- Labour
- Health and Safety
- Environmental
- Management System
- Ethics

As documented proof we require:

1. An EICC membership document
2. An annual list (that is not older than 12 months) of all third party audits of compliance with the EICC code of conduct, conducted at the first tier production facilities of TCO certified products.
3. One full report of a third party audit (that is not older than 12 months) conducted at a first tier production facility of TCO certified products.

If the brand owner cannot present a full report that has been conducted during the last 12 months, then a final option is to buy one audit (for a subsidized fee) from a third party appointed by TCO Development.

More information:

<http://www.eicc.info/>

B.7.1.1.2 SA8000

SA8000 is a global social accountability standard for decent working conditions, developed and overseen by Social Accountability International (SAI). SAI contracts with a global accreditation agency, Social Accountability Accreditation Services (SAAS) that licences and oversees auditing organisations to award certification to employers that comply with SA8000.

SA8000 is based on the UN Universal Declaration of Human Rights, Convention on the Rights of the Child and various International Labour Organization (ILO) conventions. SA8000 covers the following areas of accountability:

- **Child labour:** No workers under the age of 15; minimum lowered to 14 for countries operating under the ILO Convention 138 developing-country exception; remediation of any child found to be working.
- **Forced labour:** No forced labour, including prison or debt bondage labour; no lodging of deposits or identity papers by employers or outside recruiters.
- **Workplace safety and health:** Provide a safe and healthy work environment; take steps to prevent injuries; regular health and safety worker training; system to detect threats to health and safety; access to bathrooms and potable water.
- **Freedom of Association and Right to Collective Bargaining:** Respect the right to form and join trade unions and bargain collectively.
- **Discrimination:** No discrimination based on race, caste, origin, religion, disability, gender, sexual orientation, union or political affiliation, or age; no sexual harassment.
- **Discipline:** No corporal punishment, mental or physical coercion or verbal abuse.
- **Working hours:** Comply with the applicable law but, in any event, no more than 48 hours per week with at least one day off for every seven day period; voluntary overtime paid at a premium rate and not to exceed 12 hours per week on a regular basis; overtime may be mandatory if part of a collective bargaining agreement.
- **Remuneration:** Wages paid for a standard work week must meet the legal and industry standards and be sufficient to meet the basic need of workers and their families; no disciplinary deductions.
- **Management system for Human Resources:** Facilities seeking to gain and maintain certification must go beyond simple compliance to integrate the standard into their management systems and practices.

As documented proof we require:

1. A valid SA8000 certificate documenting compliance with the standard. The Brand owner shall be SA8000 certified or carrying out production at first tier production facilities that are SA8000 certified.
2. An annual list (that is not older than 12 months) of all third party audits conducted at the first tier production facilities of TCO certified products.

3. One full report of a third party audit (that is not older than 12 months) conducted at a first tier production facility of TCO certified products.

If the brand owner cannot present a full report that has been conducted during the last 12 months, then a final option is to buy one audit (for a subsidized fee) from a third party appointed by TCO Development.

More information:

<http://www.sa-intl.org/>

B.7.1.1.3 Self-documentation

Verification is made through completing a questionnaire provided by TCO Development. There are 10 questions concerning the brand owner's company work with implementing the minimum requirements on working conditions in the production of TCO Certified products. The answers shall be signed by the senior management representative and as far as possible supported by documentation.

To be accepted as fulfilling the TCO Development social criteria the brand owner company shall provide proof of having implemented structured CSR work with their first tier production facilities and make reasonable efforts with respects to suppliers. Our ambition is to ensure that the risk of the production not being in compliance with the requirements is minimized.

The questions cover such areas as the implementation and content of a code of conduct or similar demands on first tier production facilities, auditing and follow up of social criteria, trade union rights and representation, activities to avoid discrimination and the dialogue with suppliers.

As documented proof we require:

1. A completed and by CSR verifier approved TCO Development questionnaire. The Questionnaire and Guidelines for the assessment are public and can be downloaded at: www.tcodevelopment.com
2. An annual list (that is not older than 12 months) of all third party audits conducted at the first tier production facilities of TCO certified products.
3. One full report of a third party audit (that is not older than 12 months) conducted at a first tier production facility of TCO certified products.

If the brand owner cannot present a full report that has been conducted during the last 12 months, then a final option is to buy one audit (for a subsidized fee) from a third party appointed by TCO Development.

B.7.1.1.4 Brand owners not yet having the required CSR process in place (Grace Period).

Brand owners utilizing first tier production facilities that do not yet comply with the criteria are given a 12 month grace period to reach a level of engagement that complies.

In this case a signed guarantee by the brand owner stating an estimated date of compliance is required to be submitted with the application. It is then the verifier's responsibility to check that the brand owner has obtained a level of compliance within the grace period. If the necessary documentation is not received within the 12 month grace period then TCO Development shall be contacted by the verifier so a course of action can be decided.

B.7.1.1.5 On-site inspection instigated by the Brand owner (Social revision)

The third party auditor used by the applicant to carry out factory inspections and deliver the report, shall have documented experience of carrying out social auditing. The auditor should have undergone the SA8000 Advanced Auditor Training or an equivalent training course

B.7.1.1.6 On-site inspection instigated by TCO Development (Social revision)

TCO Development reserves the right to require full audit reports and conduct or commission on-site inspections at first tier production facilities to verify that the Brand owner is fulfilling the obligations according to this mandate. The planning of social audits will be done in cooperation with the Senior Management Representative appointed by the brand owner. Audits will be implemented by TCO Development's partner organisation for the actual geographic region. On factory level, inspections should be able to be unannounced visits. Social audits initiated by TCO Development will be realized on a judgement sample basis, in each case decided by and financed by TCO Development.